

## **Historic, Archive Document**

Do not assume content reflects current scientific knowledge, policies, or practices.



25  
79



United States  
Department of  
Agriculture

Forest Service

U.S. **Rocky Mountain  
Forest and Range  
Experiment Station**

Fort Collins,  
Colorado 80526

**General Technical  
Report RM-99**



# Snag Habitat Management :

## Proceedings of the Symposium



June 7-9, 1983  
Flagstaff, Arizona

## Preface

Some 85 species of North American birds excavate nesting holes, use cavities resulting from decay, or use holes created by other species in dead or deteriorating trees. Such trees, commonly called snags, are similarly important to numerous species of mammals, reptiles, amphibians, and invertebrates. Unfortunately, these snags have often been considered undesirable because they are not esthetically pleasing, conflict with other forest management practices, may harbor forest insect pests, or may be fire or safety hazards. The dramatic increase in demand for fuelwood has further decimated the number of dead trees left standing for cavity-dependent wildlife.

Only recently have resource managers recognized the importance of snag habitat and the problems associated with its management. The majority of cavity-nesting birds -- woodpeckers, swallows, wrens, and nuthatches, to name a few -- are insectivorous, and play an important role in the control of forest insect pests. The concept of this symposium therefore, was to recognize the problem, exchange ideas and solutions, and disperse information among land managers, industry, researchers, resource specialists, and wildlife biologists. The data and ideas presented here are urgently needed to integrate snag habitat

management with other equally valid resource uses and demands.

Rapid publication of these proceedings was due largely to the excellent efforts of the authors (and their typists!) in preparing camera-ready manuscripts. Since papers are being printed as received, each contributor is responsible for the accuracy of his or her paper; opinions expressed by the authors may not necessarily reflect the policy of the U.S. Department of Agriculture.

Many people and agencies contributed to the success of this symposium. Jerry Davis, Greg Goodwin, Gary Bateman, Richard Ockenfels, and Glen Dickens served as the Steering Committee. David Patton was instrumental in involving the Rocky Mountain Forest and Range Experiment Station in publishing the proceedings. R. H. Hamre and Phyllis West compiled the proceedings for publication. Other significant contributions were by Sandra Pinkerton, registration; Peggy Barker, university coordinator; Sandra Walchuk, posters; Richard Ockenfels, program; Jeffrey Brawn, field trip; Arizona State University Student Chapter of the Wildlife Society, audio-visual support; and Ken Byford, promotional affairs.





# **SNAG HABITAT MANAGEMENT: Proceedings of the Symposium**

**June 7-9, 1983  
Northern Arizona University  
Flagstaff**

**Jerry W. Davis, Gregory A. Goodwin, and Richard A. Ockenfels  
Technical Coordinators**

**SPONSORED BY:**

**Arizona Chapter The Wildlife Society**

**USDA Forest Service**

**Northern Arizona University**

**Arizona Game and Fish Department**

**Southwest Section The Wildlife Society**

**Rocky Mountain Forest and Range Experiment Station  
Forest Service  
U. S. Department of Agriculture**

# Table of Contents

	Page
GENERAL SESSION: Dale A. Jones, Chairman	
Welcoming Remarks . . . . . <i>Bud Bristow</i>	1
Managing Snag Habitats in Southwestern National Forests . . . . . <i>William D. Zeedyk</i>	2
Snags Are for Wildlife . . . . . <i>Jerry W. Davis</i>	4
The Role of Nestboxes in Bird Research and Management . . . . . <i>Jeffery B. Froke</i>	10
Power Pole Damage by Acorn Woodpeckers in Southeastern Arizona . . . . . <i>G. Patrick O'Brien</i>	14
Cavity-Nesting Bird Requirements and Responses to Snag Cutting in Ponderosa Pine . . . . . <i>Virgil E. Scott and John L. Oldemeyer</i>	19
Problems in Snag Management Implementation--A Case Study . . . . . <i>Edward W. Styskel</i>	24
MANAGEMENT: John D. Snyder, Chairman	
Implications of Snag Policies on Management of Southwestern Ponderosa Pine Forests . . . . . <i>Peter F. Ffolliott</i>	28
Coarse Woody Debris and Debris-Dependent Wildlife in Logged and Natural Riparian Zone Forests--A Western Oregon Example . . . . . <i>Steven P. Cline and Charles A. Phillips</i>	33
The Long-Term Effect of Timber Stand Improvement on Snag and Cavity Densities in the Central Appalachians . . . . . <i>John J. Moriarty and William C. McComb</i>	40
The Effect of Firewood Removal on Breeding Bird Populations in a Northern Oak Forest . . . . . <i>John V. Dingledine and Jonathan B. Haufler</i>	45
Management of Snags and Den Trees in Missouri--A Process . . . . . <i>Russ Titus</i>	51
Snag Management: Options and Incentives for Private Landowners . . . . . <i>Lorin L. Hicks</i>	60
Longevity of Snags and Their Use by Woodpeckers . . . . . <i>Evelyn L. Bull</i>	64
Potential Woodpecker Nest Trees through Artificial Inoculation of Heart Rots . . . . . <i>Richard N. Connor, James G. Dickson, and J. Howard Williamson</i>	68
The Use of High-Cut Stumps by Cavity-Nesting Birds. . . . . <i>Michael L. Morrison, Martin G. Raphael, and Robert C. Heald</i>	73
Direct Habitat Improvements--Some Recent Advances . . . . . <i>Andrew B. Carey and John D. Gill</i>	80

HABITAT AND SPECIES REQUIREMENTS: Gary C. Bateman and Terry B. Johnson, Chairmen	
Habitat Selection Related to Resource Availability among Cavity-Nesting Birds . . . . .	88
<i>Timothy Brush, Bertin W. Anderson, and Robert D. Ohmart</i>	
Breeding Bird Use of Flooded Dead Trees in Rathbun Reservoir, Iowa . . . . .	99
<i>Teresa L. Burns and Robert B. Dahlgren</i>	
Nestholes in Live and Dead Aspen . . . . .	102
<i>Barbara L. Winternitz and Helen Cahn</i>	
Snag Density and Utilization by Wildlife in the Upper Piedmont of South Carolina . . . . .	107
<i>D. Breck Carmichael, Jr., and David C. Gwynn, Jr.</i>	
Use of Dead Trees by the Endangered Indiana Bat . . . . .	111
<i>John T. Brady</i>	
The Importance of Snags to Pine Marten Habitat in the Northern Sierra Nevada . . . . .	114
<i>Sandra K. Martin and Reginald H. Barrett</i>	
Seasonal Selection of Tree Cavities by Pygmy Nuthatches Based on Cavity Characteristics . . . . .	117
<i>Douglas B. Hay and Marcel Guntert</i>	
Winter Communal Roosting in the Pygmy Nuthatch . . . . .	121
<i>William J. Sydeman and Marcel Guntert</i>	
Decay Characteristics of Pileated Woodpecker Nest Trees . . . . .	125
<i>Roger D. Harris</i>	
Snag Use by Selected Raptors . . . . .	130
<i>Richard L. Glinski, Teryl G. Grubb, and Larry A. Forbis</i>	
Snag Use by Birds in Douglas-fir Clearcuts . . . . .	134
<i>Bruce G. Marcot</i>	
Snags as Indicators of Habitat Suitability for Open Nesting Birds . . . . .	140
<i>John M. Marzluff and L. Jack Lyon</i>	
Nest Boxes as a Coppery-Tailed Trogon Management Tool . . . . .	147
<i>Wendy A. Hakes</i>	
Artificial Trees for Primary Cavity Users . . . . .	151
<i>Thomas C. Grubb, Jr., Daniel R. Petit, and Dennis L. Krusac</i>	
Use of Nesting Boxes on Young Loblolly Pine Plantations . . . . .	155
<i>George A. Hurst</i>	
Use of Nest Boxes in Ponderosa Pine Forests . . . . .	159
<i>Jeffery D. Brawn and Russell P. Balda</i>	
A Palo Verde Snag in the Sonora Desert . . . . .	165
<i>Charles E. Kennedy</i>	
MONITORING AND MODELING: David R. Patton, Chairman	
Cavities in Trees in Hardwood Forests . . . . .	167
<i>Andrew B. Carey</i>	
A Device for Viewing and Filming the Contents of Tree Cavities . . . . .	185
<i>Dan W. Speake and James A. Altiere</i>	

	Page
Monitoring Diurnal, Cavity-Using Bird Populations . . . . .	188
<i>Andrew B. Carey</i>	
A Simple Model to Predict Snag Levels in Managed Forests . . . . .	200
<i>Norm Cimon</i>	
Providing Snag Habitat for the Future . . . . .	205
<i>Keith A. Menasco</i>	
Cavity-Nesting Bird Response to Declining Snags on a Burned Forest:	
A Simulation Model . . . . .	211
<i>Martin G. Raphael</i>	
Predictive Models for Snag Nesting Birds . . . . .	216
<i>Russell P. Balda, William S. Gaud, and Jeffery D. Brawn</i>	
Challenges of Snag Management . . . . .	223
<i>Gregory A. Goodwin and Russell P. Balda</i>	



# Welcoming Remarks<sup>1</sup>

Bud Bristow<sup>2</sup>

The Arizona Game and Fish Department is pleased to be a co-sponsor of this Symposium on Snag Habitat Management. That seventeen states, numerous Federal and State Agencies and Universities are represented is testimony to the interest at all levels in snag management.

The Arizona Game and Fish Department has long realized the value of snags to many species of our state's wildlife. For example, over 70 species of birds and mammals use snags on the Coconino Forest. Work done on turkeys by Fred Phillips, one of the Department's Wildlife Managers, focused on the importance of snags as roosting sites. The value of snags to Arizona's cavity nesting birds are well documented.

We are also aware that many of our existing snags may be jeopardized by current commercial timber and fuelwood management practices. Cable suspension logging is starting to cut into resources of snags in canyons and on the steep hills. Improper removal by the public for fuelwood is taking its toll. The Game and Fish Department is not a land management agency and, therefore, is limited to how it can directly affect the management and protection of snags. Currently, we do not have a snag management policy. The Department is, however, moving toward a policy on commercial timber harvest that will increase our involvement in timber

---

<sup>1</sup>Paper presented at the Snag Habitat Management Symposium, [Northern Arizona University, Flagstaff, Arizona, June 7-9, 1983].

<sup>2</sup>Bud Bristow is Director of the Arizona Game and Fish Department, Phoenix, Az.

management practices, and will hopefully provide for maximum diversity of age-classes in all forest types.

A term I'm sure we're going to hear more and more is holistic. This concept is old; as old as wildlife management, and as old as a land ethic. It still is not an accepted practice in principle on our public land. It is a term we had better see in use, however, if our resource responsibility, wildlife, is to survive. We must continue to plan and negotiate management methods beneficial to wildlife. Otherwise, we can lose more during this current production-oriented period than we gained in all the accumulated restoration of decades of good management.

Several questions come to mind when snags are considered. The first and most obvious is where will tomorrow's come from? The 12" saw timber cutting cycle?

What are we doing to stop the rapid loss from illegal fuelwood cutting? Are we to have a natural complement of age classes surrounding the snags?

We have the answers we need for most management decisions. Refinement of particulars is desirable, but management won't wait until all the answers are in. We must make a commitment to management of our future snag and old growth resource. Hopefully, this symposium will act as a catalyst to develop a strong interest in snag management at all levels and generate further study.

Again, I wish to welcome you on behalf of the Arizona Game and Fish Department and I look forward to an enlightening and invigorating symposium.

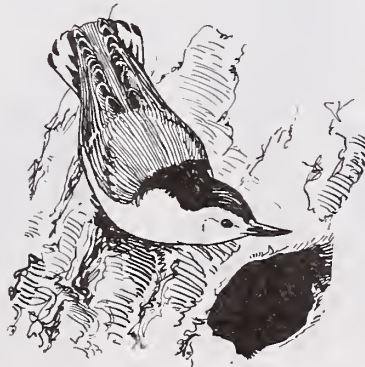



# Managing Snag Habitats in Southwestern National Forests<sup>1</sup>

William D. Zeedyk<sup>2</sup>

## INTRODUCTION

The Forest Service is pleased to participate with Northern Arizona University, Arizona Game and Fish Department, and The Wildlife Society as a co-sponsor of this important symposium on the management of snag habitats

There is now general recognition that snag habitats are of high importance to a wide variety of wildlife species. Various laws, regulations, departmental and agency policies imply that snag habitats be recognized and managed as a necessary component of forest diversity and to sustain viable populations of native wildlife.

Much information is now available, but much more is still needed to enable the wise management of the snag habitat resource in harmony with other multiple use-sustained yield resources of the forest. This symposium is providing a long overdue forum for exchange of such information and will be valuable to the Forest Service as land management planning continues.

## SITUATION

During the course of this symposium, you will learn again and again of the many species of vertebrates that need snags and why they need them. Birds need snags. Mammals need snags. Reptiles need snags. Even fish need snags in the form of down logs imbedded in the streambanks. The facts are well-known and well-accepted among wildlife biologists, foresters, planners, and land managers.

The question is no longer one of need. The question is: What options does the land manager have available for providing adequate snag habitats to meet wildlife management objectives without creating unacceptable impacts on other resource uses? What yield of wood fibre must be diverted annually per unit of area to perpetuate snag dependent wildlife at desired population levels? What are the most efficient ways of providing snag habitats? Can we perpetuate snags without creating unacceptable safety hazards? Can we perpetuate snags without creating an unacceptable insect and disease menace or fire hazard. Do the needs and opportunities vary by ecosystem?

Unfortunately, it is not sufficient to say that snags are necessary and provide useful functions in the managed forest. Maintaining snag habitats diverts wood fibre away from other uses, involves opportunity costs, and drains revenues. Snags, like most products of the forest, are a renewable resource, but their management causes conflicts. The Forest Service is cognizant of the need for snags and is determined to resolve, to the greatest extent feasible, conflicts between snag habitat management and other resources.

## SOME PROBLEMS FACING MANAGERS OF SNAG HABITATS

1. Characteristics and attributes of snag habitats vary widely between biotic communities or forest types. Managers need more information on the relationships existing between dependent wildlife species and the dominant tree species characteristic of a particular forest type. Such information can be used to determine the relative importance and identify conflicts with other resource demands. In the ponderosa pine type, for example, one species, the pine, must provide all the needs; but in the gambel oak-ponderosa pine type, a portion of snag habitat requirements can be met by large oaks, releasing some pine volume to meet sawtimber demands.

In the Southwest, there is a considerable volume of information available on snag habitat requirements of cavity nesting species inhabiting the ponderosa pine and mixed conifer types, but relatively little on spruce-fir, aspen, pinyon-juniper, or riparian forest types.

2. Due to the requirements of the National Forest Management Act and the National Environmental Policy Act, there is great emphasis being placed on habitat monitoring. Managers need efficient monitoring systems that will establish and track conditions and trend in snag habitat quality and abundance by forest type and land area. Ideally, snag habitat monitoring systems will be compatible with other resource monitoring activities, and any needed information will be collected in conjunction with other resource inventories.

3. Forest land and resource plans being developed pursuant to the National Forest Management Act and accompanying regulations place a great deal of reliance on the management indicator species concept to predict the effects of alternative prescriptions on wildlife. There is a critical need to test the management indicator species concept to establish beyond reasonable doubt that trends in the status and distribution of selected indicator species are truly representative of the

---

<sup>1</sup> Paper presented at the Snag Habitat Management Symposium. (Flagstaff, Arizona, June 7-9, 1983)

<sup>2</sup> William D. Zeedyk, Director of Wildlife Management, USDA, Forest Service, Region 3, Albuquerque, N.M.

snag habitat dependent species they are intended to represent. Management indicator species typically selected for National Forests in the Southwest include such dependent species as pygmy nuthatch, hairy woodpecker, and plains titmouse. Do these species fairly represent the needs of other cavity nesters utilizing snag habitats in their respective ecosystems?

4. An educational program is needed to gain public knowledge and appreciation for the value of snag habitats. While there is increased internal acceptance within the Forest Service of the need to maintain some standing snags and downed logs for wildlife, the public may see this as a poor management practice and wasteful of the fuelwood resource.

5. All efforts to manage snag habitats for wildlife that may result from more enlightened forest management will fail in accessible areas if the now rampant illegal cutting of standing and down woody material for fuelwood is not brought under control. This is perhaps the most urgent threat to snag habitat protection facing land managers in the Southwest. Because trained personnel available for law enforcement are scarce and regulations pertaining to fuelwood possession weak, many snags retained during commercial logging

activities are soon taken illegally after a sale closes.

6. A concerted effort by wildlife biologists, silviculturalists, timber sale administrators, and safety inspectors is needed to develop improved practices for identifying and safeguarding snags and potential snags for retention in sale areas. Many otherwise suitable potential snags are destroyed inadvertently because live cull trees are marked for cutting which might be retained. Isolated snags are felled as safety hazards where they might be retained if included within clumps of unmarked leave trees.

#### CONCLUSION

There is an established and growing acceptance of the value of snags for wildlife. Managers agree that snag habitats are needed and have a role in the managed forest, but a number of questions need answering. The main question is: What options are available to forest managers to perpetuate snag habitats at acceptable levels while addressing other public issues and management concerns? Hopefully, this symposium will provide some answers and point the way to resolving some of the conflicts inherent in protecting snag habitats in the managed forest.





# Snags Are for Wildlife<sup>1</sup>

Jerry W. Davis<sup>2</sup>

---

Abstract - - Snags provide habitat for many wildlife species. This habitat is used to meet physiological and behavioral needs. Snag habitat awareness and management has improved in the past decade, but problems persist. It is time to implement solutions and to manage snag habitat on a sustained-yield, in perpetuity, for wildlife and the health and viability of the ecosystem.

---

## INTRODUCTION

The statement "snags are for wildlife" may bring several thoughts and impressions to mind.

To some it may appear argumentative or threatening. Others may perceive it as wishful thinking, a condition that should be but is not, or a biological fact. Regardless of the point of view, snags provide essential habitat for wildlife and perform a vital role in the ecosystem.

## A SNAG IN THE SYSTEM

My first thought in writing this paper was to use data from the many papers in my files to prove beyond a doubt, to anyone with an open mind, that snag habitat and snag-dependent species are valuable and worth saving. The proof of purpose and value of snags and wildlife in the system, however, has already been well documented.

Snags provide essential habitat for 85 species of North American birds that either excavate holes, use natural cavities, or use holes created by other species (Scott et al. 1977). Additional bird species use the external portions of snags to meet habitat needs.

Mammals, reptiles, amphibians, and invertebrates also need snags. A limited review of Burt and Grossenheider (1964), Davis (1960), and supplemented by personal knowledge, indicate a minimum of 49 species of mammals that use natural and created cavities in snags. The dependency of these species on snag habitat may not be as well documented as that of cavity-dependent birds, but

this does not diminish the fact that snags are important to mammals.

Snags provide habitat for wildlife to meet basic behavioral and physiological needs. Such needs include but are not limited to:

Singing	Viewing	Hawking
Pecking	Seeking	Capturing
Drumming	Grooming	Perching
Excavating	Incubating	Brooding
Reproducing	Hibernating	Roosting
Hunting	Landing	Feeding
Loafing	Regulating	Gleaning
Nesting	Constructing	Estivating
Resting	Enticing	Plucking
Courting	Competing	Defending
Preening	Escaping	Rearing
Wedging	Communicating	Raking
Hiding	Observing	
Storing	Climbing	

Snag habitat and cavity nesters are as necessary to the Forest as the trees.

Some people believe that a forest can exist without these components, but I am not one. Little do they understand the intricacy of the system, and those that cannot understand will eventually eliminate these components and the forest.

## REFLECTIONS OF PROGRESS

In preparation for this symposium, it was only natural for me to reflect upon the progress that has been made in the past 10 years. In these reflections, I could not help but have mixed feelings.

When I transferred to the West in 1972, I, like maybe some of you, had not really given much thought to the value of snags as wildlife habitat. Yes, I had grown up observing standing dead trees in the forest. They were the trees that one could

---

<sup>1</sup>Paper presented at the Snag Habitat Management Symposium [Flagstaff, Arizona, June 7-9, 1983].

<sup>2</sup>Jerry W. Davis is the Forest Wildlife Biologist, USDA Forest Service, Tonto National Forest, Phoenix, Arizona 85038



tap and watch owls, bats, rats, woodpeckers, bluebirds, and flying squirrels come out of the holes. On occasion, unexpected occupants including lizards, bees, wasps, and mosquitoes, would emerge. Many of the squirrels that the dog treed were in hollows, and the old trees with the hole at the base seemed to be where the rabbit would take cover when chased by a dog.

Dead trees were present and were considered part of the forest. When they fell, the logs were also accepted. Logs were turned over by curious boys to find rodents, snakes, lizards, and invertebrates. Logs produced "wood sawyers" and other insect forms that were used to catch the fish laying under the logs in the river.

All of these stages - the dead tree, log, and large woody debris - were accepted as an important and functional part of the system to which they contributed.

In 1972, I was surprised to find that snags and logs were not being accepted as part of the forest, although data indicated over sixty species of wildlife on the Kaibab National Forest used snag habitat. There was, and had been for many years, a conscious effort to remove snags from the system. Timber sale contracts required the purchaser to fell a specified number of snags, and he was given purchaser credit to do so. Salvage sales scheduled between timber sales insured that fewer trees "went to waste." Fire management called snags "lightning rods" and perceived them as standing beacons to attract fire. Other professional disciplines viewed the presence of snags as a disgrace and a waste.

It was during the early 1970's that a forester proudly announced that the last snag had been removed from one of the National Forests in Arizona. Decades of snag removal had been effective on accessible areas of other Forests as well.

In July 1973, snag management began to improve with the approval of a Regional Snag Management Supplement (USDA 1973). It required that a snag determine its own value by retaining those being used by wildlife. In addition to snag protection in timber sales, it requested Forest Supervisors to issue manual supplements protecting them from woodcutters.

Forest snag management supplements did follow in time. In July 1974, the Kaibab National Forest had an approved supplement which provided snag retention except in clear cuts, fuelbreaks, recreation areas, travel influence zones, and hazardous snags which by virtue of their position posed a hazard to fire protection. Timber markers were required to designate with paint those snags to be removed rather than mark the snags to be retained (USDA 1974).

Some may not see this as progress, especially with all of the exceptions, but in the early days

of snag habitat recognition, it was progress. It was also progress to later reduce salvage sales, protect snags in timber sale contracts, and reduce the size of fuelbreaks from 48 percent of the total area for some sales, to 8 percent or less. Management data and improved awareness and attitudes seemed slow in happening. But they did happen and so did the improvement of Regional and Forest snag management policies.

The evolution of data were also necessary. It was not enough for a wildlife biologist to identify the problem and request snag habitat. Published data were needed to support answers to even the most basic questions of how many and what kind of snags should be retained.

Balda (1975) and Scott (1978) provided some of the answers. Balda, working with secondary cavity nesters in natural ponderosa pine forests, supported maintaining 268 snags per 100 acres. Scott's research supported 2.5 snags per acre as the lower rather than the upper limit. Scott also supported retaining snags greater than 15 inches dbh, taller than 75 feet, and greater than 40 percent bark cover.

Cunningham, Balda, and Gaud (1980) revised Balda's 1975 data to support densities of 5.2 snags per hectare, emphasized the importance of bark, and determined a relationship between the number of nest sites to snag density. The value of snags as winter roosts and the importance of size and height were also determined.

Since the mid-1970's there have been numerous papers providing data on snag habitat and cavity dependent species. Most of these papers have been published in the past few years. Classification terminology, including hard and soft snags, and primary and secondary cavity nesters, were once seldom heard. Today they are commonly used and recognized.

It is exciting to be a part of the first snag management symposium. Letters and telephone calls of support have been received from throughout this nation, Canada, and Australia. The Reston Home Owners' Association sent a copy of the guidelines that are used to manage 1,000 acres of open space to protect snags and encourage cavity users.<sup>3</sup> A letter received from the Connecticut Department of Environmental Protection expressed their personnels' inability to attend the symposium but enclosed a copy of the State's guidelines for snag management. These guidelines included criteria for snag selection, size, distribution, management density (3-7 snags per acre), and future snag production.<sup>4</sup>

---

<sup>3</sup>Thompson, Claudia. 1983. Personal correspondence. Reston Home Owners' Association. Reston, VA.

<sup>4</sup>Lutz, Karl J. 1983. Personal correspondence. State of Connecticut Dept. of Environmental Protection. Marlborough, CT.



Exciting things are happening in snag habitat management and progress has been made. Many people seem to be extending their ideas beyond the utilitarian philosophy. They are saying that wildlife and other elements of the ecosystem have an important purpose whether we have justified their existence economically or not. Society is expressing discontent with the management of our forests as wholesale warehouses for commodity shoppers, and support the right of existence for wildlife and plant species.

With so many positive things happening, it is easy to become dazzled by our own fancy footwork and assume that the problem is solved. Progress has been and continues to be made, but we are not there yet.

#### PROBLEM RECOGNITION

The first step to solving a problem is to realize that a problem exists. Problem recognition is not always easy and may be blurred by personal values, underlying philosophies, insensitivity, and limited knowledge.

When I was growing up in East Texas, my father had a farm adjoining Davy Crocket National Forest. One day when we were working, he pointed out a red-headed woodpecker (Melanerpes erythrocephalus) constructing a nest cavity in a Texas Power and Light Company utility pole. "That woodpecker is my fence builder," he said. "Woodpeckers need a place to nest and since there are not many dead trees anymore, they build their nests in utility poles. When the company replaces the poles, I buy the damaged poles for fence posts."

Today, woodpeckers are still using utility poles. Continental Telephone of Texas reports that 12.5 percent (204) of the poles replaced in 1981 was because of woodpecker damage.<sup>5</sup>

Texas Power and Light Company reports that in the past four years, pole damage has been due to decay below ground, damage by vehicles, lightning strikes, and woodpecker damage, in that order. L.S. Huntsinger, Division Superintendent, said "We do have many poles that sustain woodpecker damage that are not replaced. In our transmission lines which are generally taller we have a large percent of woodpecker damage; however, this has been offset to a great degree because we now wrap one-quarter inch wire mesh around these poles."<sup>6</sup>

In the 1950's there were reports of a decline in wood duck (Aix sponsa) and Eastern bluebird (Sialia sialis) populations. A milk company tried to improve the nest habitat for bluebirds by pro-

ducing milk cartons with instructions on how to convert them into nest boxes. Many people responded and there seemed to be a temporary increase in bluebirds.

I spent hours fishing on lakes constructed by the Corps of Engineers and was amused watching cavity nesters using the few snags standing above the water surface. Little did I think at the time that these few snags were token remnants of a forest that would never provide a self-sustained supply of snags again.

These and other examples illustrate symptoms of the problem. The problem is a rapidly declining habitat for snag and cavity dependent species. This problem has many symptoms and many causes which are not unique to this nation, but are worldwide. It is a problem that can be recognized, whether it be by the use of nest boxes in the intensively managed forests of Europe or by the rapidly disappearing forests of countries that are mining timber resources to meet world trade and balance of payment demands. Symptoms of this problem can even be observed at your local zoo by noting the cavity nesting species that are in trouble all over the world.

There are many causes contributing to the problem. One has only to think about the diverse influences altering the composition, density, and existence of our forests. Causes can be as obvious as extensive type conversions for the development of agricultural lands, for urban expansion, or establishing short rotation monoculture tree farms. They can be as subtle as the change in forest age classes, species composition, and rotation, or as quiet as the almost indiscernable grazing of livestock on cottonwood and sycamore regeneration.

Although most causes of the problem are obvious, some may still fail to be recognized because of a limited knowledge. Some people, however, do not recognize the problem and its causes because for one reason or another they choose to believe that everything is still OK. They could be compared to a man jumping off of Hermit's Rest at the rim of the Grand Canyon to the Colorado River a mile below. As he falls, he can be heard saying as he passes each 500 foot mark "everything is still OK, everything is still OK...". It is that sudden realization at the end of the line that is going to have the impact and then it will be too late.

Everything is not OK and the sooner we realize that a problem exists and start working toward resolving the causes of the problem, the better off all resources, and non-resources, will be.

Some of the causes of the problem are unique to localized areas, whereas others, such as fuelwood demand, both legal and illegal, and timber management practices, have a common thread nationwide.

<sup>5</sup>Fryer, Jim. 1982. Personal correspondence. Continental Telephone of Dallas. Dallas, TX.

<sup>6</sup>Huntsinger, L.S. 1982. Personal correspondence. Texas Power and Light Company, Tyler, TX.



Fuelwood demands have developed at a significant rate since the 1974 oil embargo. It is possible that much of the fuelwood problem was self-inflicted due to improper planning, inadequate funding, and an eagerness to advertise free fuelwood to encourage everyone to save fossil fuels. During this period of energy crisis, to burn fuelwood was not only patriotic but was supported by economic motivation.

Americans responded by installing fireplaces and woodburning stoves. These not only were thought to be essential to save energy but became a status symbol as well. This cultivated the Paul Bunyan syndrome. Forest dead and down fuelwood was not enough; the budding Paul Bunyans had to cut and watch their own trees fall. Forests and private landowners who had just a few years before paid to have trees pushed, piled, and burned were now faced with a limited supply.

Demand continues to increase and so does the fuelwood support industry. Baker (1983) reports that this nation burns over 40 million cords of wood per year to meet about one percent of our energy needs. He estimates that this will triple in the next decade.

Forty million cords of wood represent a stack of wood 4x8 feet, 30,303 miles high. If this use triples as projected it will take this nation less than three years to use a stack of fuelwood 4x8 feet extending from the earth to the moon.

Fuelwood use has been re-ingrained in the American lifestyle and continues even if it is not economical. Fuelwood users in the Phoenix area may pay \$100-\$140 per cord. In an improved fireplace, they will only receive \$20 of natural gas BTU equivalents.<sup>7</sup>

Fuelwood demands are real, and so are the adverse impacts that rampant illegal cutting is incurring on the management efforts to replace and maintain snag habitat.

The management of forested lands with emphasis on the production of commodity products also adds to the problem of snag habitat management. Increasing demands are being made to produce more wood products from a renewable yet finite timber resource.

It is the same land and forest base that must provide wildlife habitat for indigenous species. Yet, the inadequacy of parity between commodity and noncommodity outputs pose questions that need answers.

I see intensified timber management and harvest through shorter rotations, even-aged management, fire suppression and fuels control, optimum spacing, frequent re-entries, and aggressive insect

and disease control. I watch the final removal of mature timber from the last stands. Even areas that were once inaccessible and uneconomical to harvest and were said to be left for wildlife are now being harvested.

With more intensive management, shorter rotations, and healthier forests, I question if we are prepared mentally, and will support financially and with research data, efforts to create adequate snag habitat. Under these conditions, it may be unrealistic to expect adequate snag habitat through natural mortality.

Timber management policy and practices have the greatest potential to contribute to or resolve the causes to the problem of inadequate snag habitat.

#### PROBLEM RECOGNITION - NOW WHAT?

I do not have great words of wisdom that I can give you to solve the problem. I believe, however, that by recognizing the problem and surfacing causes and concerns, that the solutions can be implemented. It cannot be solved by wildlife biologists alone, but it will take a multifaceted, multidiscipline approach looking at the problem from the various viewpoints.

I am hopeful that the papers and data presented at this symposium will be a turning point in solving the problem. It should provide an opportunity to exchange information and ideas, and the published proceedings will provide a reference to professionals of all disciplines. We cannot, however, be content with these efforts and brief exchanges.

After this symposium, we do not need to continue talking to ourselves. We are not the ones that need to be convinced that snag habitat and its dependent species are of value and are worth saving. If there is one person in this nation that is not aware of the values of snag habitat, that is one too many.

There must be an improvement in attitudes, awareness, and sensitivity. We need to reassess our management purpose and revive our land ethic. I do not feel that the true intent of multiple use can be met unless all are willing to adjust the way that it has been applied. The reason that snag habitat is in trouble is that its value has not been generally perceived although the value is there. All need to be advocates for total resource management.

Researchers must remember that decisions are being made everyday, whether data and answers are available or not. This obligation goes beyond getting data in print. You are in the position and have the background to be most sensitive to resource needs, provide data, and help integrate the multiple needs and demands that are made on finite resources.

---

<sup>7</sup>Davis, Jerry W. 1980. Unpublished Paper. Fuelwood Cents. Phoenix, AZ.



Researchers and managers alike must be careful not to get trapped on the data carrousel or use the lack of data as an excuse for inaction. Data alone will not solve the problem. We must be careful not to be a society with volumes of data in print and lose the resource because the solutions were never implemented.

Resource managers should support the concept that this habitat and its species are not just for the wildlife biologists but are everyone's resource and management responsibility. Wildlife biologists do not need snag habitat anymore than the manager, forester, recreationist, educator, or commodity interest. Snag habitat should be managed as intensively and with as much enthusiasm, dedication, and commitment as other resources. Concern should be as great for the illegal removal of snags as it is or would be for the illegal removal of commodity species.

The managers of public lands and industry alike should reassess the abilities of these lands to produce commodity products with equal consideration for other resource needs. We must face on-the-ground production realism vs. unrealistic production figures.

Every discipline must realize that it is our obligation to relinquish the land resources to future generations, with nothing less than its inherent potential to produce, and not in a diminished, but in an enhanced, condition. To do anything less than this means that we have been a failure in managing the resource and meeting the intent of our purpose.

John McGuire (1982), past Chief of the Forest Service, said that the National Forest System began as an experiment in public land ownership with the aim to insure a nondeclining, even flow, decade by decade, forest by forest, in perpetuity. This policy, he said, was not specifically written into the law, but was an agency interpretation. This interpretation was controversial, so Congress adopted as law the even flow interpretation of sustained-yield policy.

To manage resources on an even flow, sustained yield, in perpetuity means that we should manage them on a non-declining basis through eternity. Snag habitat and its associated wildlife species are such resources.

I am proud of the leadership that the Forest Service has taken in the past to recognize the special habitat values of riparian habitat, the management of nongame birds, and the cosponsorship of this symposium. I think that it would be appropriate to have another symposium in the Fall of 1985 to pull together data on the management of wildlife species requiring special habitat components. The symposium should include data on snags, hollow trees, cavities, logs, forest litter, and woody debris as they relate to the terrestrial and aquatic systems.

## CONCLUSION

Snags provide essential habitat for wildlife, and their value to the forest system is irrefutable. We have made progress in the past decade, but the problem of inadequate snag habitat persists. If we are going to solve the problem, everyone must realize that a problem exists and be willing to implement solutions. Professionals from all disciplines must maintain an acute sense of resource awareness and urgency. We must remember that published data alone will not solve the problem.

As we work toward problem solutions, we should keep in mind the works and resource ethics of a forester who walked the forests of the Southwest six decades ago. Aldo Leopold (1966) said, "A system of conservation based solely on economic self-interest is hopelessly lopsided. It tends to ignore, and thus eventually to eliminate, many elements in the land community that lack commercial value, but that are (as far as we know) essential to its healthy functioning. It assumes, falsely, I think, that the economic parts of the biotic clock will function without the uneconomic parts."

Leopold also said: "The outstanding scientific discovery of the Twentieth Century is not television, or radio, but rather the complexity of the land organism. Only those who know the most about it can appreciate how little is known about it. The last word in ignorance is the man who says of an animal or plant: What good is it? If the land mechanism as a whole is good, then every part is good, whether we understand it or not. If the biota, in the course of aeons, has built something we like but do not understand, then who but a fool would discard seemingly useless parts? To keep every cog and wheel is the first precaution of intelligent tinkering."

That is our job as resource managers and professionals. It involves saving all of the pieces in adequate quantities to maintain an efficient and viable ecosystem on a sustained-yield for the present and for the future.

Snag habitat and its associated wildlife are important pieces that we must retain.

Snags are for wildlife.

## LITERATURE CITED

- Baker, Andrew J. 1983. New findings on wood fuel values. *American Forests* 89(2):45-47, 51-52.
- Balda, Russell P. 1975. The relationship of secondary cavity nesters to snag densities in western coniferous forests. *USDA Forest Service Wildlife Habitat Technical Bulletin* 1, 37 p. Southwestern Region, Albuquerque, N.M.

- Burt, William Henry, and Richard Philip Grossenheider. 1964. A field guide to the mammals. 284 p. Haughton Mifflin Co., Boston, MA.
- Cunningham, James B., Russel P. Balda, and William S. Gaud. 1980. Selection and use of range by secondary cavity-nesting birds of the ponderosa pine forest. USDA Forest Service Research Paper RM-222, 15 p. Rocky Mountain Forest and Range Experiment Station. Fort Collins, CO.
- Davis, William B. 1960. The mammals of Texas. Texas Game and Fish Commission, Bulletin 27, 252 p. Austin, TX.
- Leopold, Aldo. 1966. A Sand County almanac with other essays on conservation from Round River. 264 p. Oxford University Press, NY.
- McGuire, John R. 1982. The National Forests: an experiment in land management. Journal of Forest History 26(2):84-91.
- Scott, Virgil E. 1978. Characteristics of ponderosa pine snags used by cavity-nesting birds in Arizona. J. For. 76(1):26-28.
- Scott, Virgil E., Keith E. Evans, David R. Patton, and Charles P. Stone. 1977. Cavity-nesting birds of North American forests. USDA Forest Service Agricultural Handbook 511. 112 p. Washington, D.C.
- U.S. Department of Agriculture. 1973. Direct Habitat Improvement Work. Forest Service Manual 2632. R-3 Supplement No. 14, July.
- U.S. Department of Agriculture. 1974. Snag felling. Forest Service Manual 2481.22. Kaibab National Forest. Forest Supplement No. 14. July.





# The Role of Nestboxes in Bird Research and Management<sup>1</sup>

Jeffrey B. Froke<sup>2</sup>

---

Abstract.-- Modern management of cavity-nesting birds has evolved from over 240 years of nestbox use by humans. Species have been maintained using nestboxes for economic, aesthetic, scientific, and conservation purposes. Implications of nestbox studies for management, including several risks of using nestbox derived data, are discussed.

---

## INTRODUCTION

Progress in the scientific study and management of cavity-nesting birds in this century is largely due to the creative and extensive use of nestboxes. Detailed information on breeding biology and population dynamics of several species (e.g., the Great Tit *Parus major*, Pied Flycatcher *Ficedula hypoleuca*, and Eastern Bluebird *Sialia sialis*) is available because of their readiness to nest in boxes. At least 102 bird species are represented in nearly 1,000 nestbox-oriented studies in the international literature.

This paper presents historical background, and discusses implications of nestbox studies for wildlife management in artificial and natural cavity habitats. Properly used, nestbox-derived data are potentially useful to the design of snag management prescriptions by wildlife biologists and foresters.

## HISTORICAL BACKGROUND

### Pre-20th Century

Carolus Linneaus (in Phillips 1925) reported that Scandinavians over 240 years ago hung nestboxes in trees for Common Goldeneyes (*Bucephala clangula*) to provide a harvestable supply of eggs for human consumption.

In North America, the Purple Martin (*Progne subis*) benefited from the hospitality of Indians and white settlers, and they from the presence of the martins. Alexander Wilson (1831) wrote: "even the solitary Indian seems to have a particular respect for this bird. The Chactaws and Chickasaws cut off all the top branches from a sapling near

---

<sup>1</sup>Paper presented at the Snag Management Symposium, Northern Arizona University, Flagstaff, 7-9 June 1983.

<sup>2</sup>Jeffrey B. Froke is Sanctuary Manager, National Audubon Society, Trabuco Canyon, Calif.

their cabins, leaving the prongs a foot or two in length, on each of which they hang a gourd, or calabash, properly hollowed out for their convenience." John James Audubon (1831) observed the relationship between the Indians and martins, and explained: "the bird keeps watch and sallies forth to drive off the Vulture that might otherwise commit depredations on the dear-skins or pieces of venison exposed to the air to be dried." Mark Catesby (1731) noted that the settlers of Florida and the Carolinas had adopted the Indian's accommodations to martins: "they breed like Pigeons in Lockers prepared for them against Houses, and in Gourds hung on Poles for them to build in, they being of great Use about Houses and Yards for pursuing and chasing away Crows, Hawks, and other Vermin from the Poultry."

Audubon (1831), in his dedicated scientific travels, noted that: "Almost every country tavern has a martin box in the upper part of its sign-board."

### 20th Century

Economic values of martins, bluebirds, and other insectivorous cavity-nesting species have continued to justify their management using nestboxes to the present day. W.L. McAtee (e.g., 1940) with the Bureau of Biological Survey, performed extensive experiments using nestboxes to increase numbers of birds for control of nut weevils and other injurious insects in orchards. Since McAtee's work, there have been numerous major research programs dedicated to increasing insectivorous bird populations in timber and food crop environments; and Russian ornithologists (see Poznanin 1956) particularly have used large number of nestboxes for this purpose.

At the 1930 meeting of the International Committee for Bird Preservation, chaired by National Audubon Society president T. Gilbert Pearson, Sokolowski (1931) described Poland's new national nestbox program aimed at replacing disappearing old-growth forests suitable for cavity-nesting birds. Following an epidemic of noctuid caterpillars which deforested much of Poland, boxes designed by Sokolowski and suitable to 16 species were widely used



by private citizens and the government in every national forest. Manufacture of tens of thousands of nestboxes was the job of prison workshops, schools and other state institutions. Massive nestbox projects for forest and orchard insect control continue today to characterize Polish ornithology (e.g., Graczyk 1974, Graczyk et al. 1970).

In 1930, Musselman (1934, 1940) was concerned about the effects of habitat loss on Eastern Bluebirds in Illinois, and noted that the old-time fences, wood fence posts, and stubs of apple trees which formerly had hosted the excavations of Downy Woodpeckers (*Picoides pubescens*) and, by inheritance, the nests of bluebirds, had disappeared. The fences had been replaced by iron and wire, while modern horticulture dictated that orchard trees be trimmed and stubs be painted. Musselman promoted the use of nestboxes to fill the nest site deficiency and to stem the decline of bluebirds. The now popular and effective institution of nestbox projects including multi-state and -province "trails", hundreds of miles long with thousands of monitored and maintained boxes is accredited to Musselman; and the subject has been carefully reviewed by Kibler (1969).

Frank Bellrose (1976), who has been a luminary in American waterfowl management, reminded us that in the early 20th century, the Wood Duck (*Aix sponsa*) was feared to follow the Laborador Duck (*Camptorhynchus laboradorius*) into extinction. Overhunting caused the decline before rigid enforcement of new protective laws permitted its dramatic increase into the 1940's. It was apparent to waterfowl managers, however, that suitable nest sites were in short supply, and that a saturation of available breeding habitat was close at hand. Consequently, in 1939, personnel of the Illinois Natural History Survey erected several hundred boxes for the ducks, and witnessed a 52% occupancy in the first season. Bellrose (1976) emphasized the drastic impacts of bottomland drainage and timber harvest on Wood Duck populations, and left the question of determining to what extent there is a "trade-off" between an increase of duckling production from nestboxes, and a population decline due to loss of natural habitat.

Incidentally, Hesselschwerdt (1941) prepared an economic analysis of the Illinois duck box project, and summarized that in addition to ducks, 56 boxes constructed at a cost of \$98 and placed in a 4 square-mile farmland, during the first 2 years produced a total of 32 young Screech Owls (*Otus asio*), 19 young American Kestrels (*Falco sparverius*), 37 young Fox Squirrels (*Sciurus niger*), 112 pounds of honey, and good winter shelter for a number of wildlife species.

Concurrent early waterfowl programs in Scandinavia included the nestbox work of Siren (e.g., 1951) on Common Goldeneyes in Finnish lakes, and Grenquist (e.g., 1953) on Gooseanders (*Mergus merganser*) on the Finnish archipelago. In similar spirits as Purple Martins which nested in empty jugs provided by early American settlers, Finnish Gooseanders benefited from the secondary values of old packing cases for whiskey and brandy that had washed ashore from passing vessels. Later, these

cases were brought directly from Helsinki by Grenquist and colleagues.

Since the early scientific observations by Wolda (1917) and others that populations of certain passerines could be increased and controlled by use of nestboxes, there has evolved an abundance of detailed long-term studies on the Great Tit (see Perrins 1980), Pied Flycatcher (see von Haartman 1971), and other Eurasian species. The Wytham Woods program of the Edward Grey Institute near Oxford, and the "hole-breeders programme" of the Vögelwelt Helgoland in Germany are particularly notable for extensive field investigation of cavity-nesting birds using nestboxes and banding.

#### IMPLICATIONS FOR MANAGEMENT

Although there are clear advantages of nestboxes as research tools (i.e., accessibility of nests, eggs, and birds; experimental control, etc.), there are risks involved in relying on boxes as primary sources of breeding data. Van Balen et al. (1982) reviewed and presented new data on the problems of nestbox populations deviating from populations occupying natural nest sites in: 1) breeding density, 2) composition of breeding species, 3) clutch size, and 4) nesting success. The authors argued that, with the exception of their present study and that of Nilsson (1975), too few systematic studies of cavity-nesting birds in natural cavities are available to give relevance to box-derived data.

#### Population Trends

In their 30-year study of Screech Owls in Ohio, VanCamp and Henny (1975) stated that boxes may affect bias in data, particularly in terms of population trends and rate of annual recruitment. They warn that trends in regional populations should not be based on percent of box-occupancy each year, because boxes are often placed in optimal habitat, and population changes caused by alteration of suitable natural habitat would be underestimated by this approach. Box and cavity data should be segregated for population estimates.

#### Nestbox Preference

Preference by birds for nestboxes over natural cavities apparently is common in several species. Ben Pinkowski (1976) reported 72% selection of boxes by pairs of Eastern Bluebirds in an area where natural cavities were available; and he suggested that boxes may have been selected because they were in more suitable locations and had more optimal interior dimensions.

In order to evaluate the cost-effectiveness of a Mississippi Wood Duck nestbox project which had a box utilization rate of more than 90%, Strange et al. (1971) investigated the availability and possible duck use of local natural cavities; and found that, although tree cavities were available, none was used due to an apparent preference for nestboxes.



Relative nesting success in nestboxes versus natural cavities is a major consideration for management which aims to sustain populations by natural reproduction. As part of a 12-year study of Black-bellied Whistling Ducks (*Dendrocygna autumnalis*), Bolen (1967) found predation to be a major factor of nest failure in boxes and natural sites: natural cavities and boxes without predator guards had 44% and 46% nest success, respectively; and boxes with guards had 77% nest success. Similar data of Bellrose et al. (1964) for Wood Ducks included 40-49% in natural cavities, 36% in unprotected boxes, and 73% success in boxes with predator guards.

Accepting Kalmbach's (1939) conclusion that 70% minimum nest success is required for satisfactory waterfowl management, these data for Wood Ducks and whistling ducks indicate the futility of erecting unprotected nestboxes or relying on non-modified tree cavities for duckling production.

L.F. VanCamp and C.J. Henny (1975) contended that due to a reduction of European Starlings (*Sturnus vulgaris*) in boxes within the feeding area of Screech Owls, Wood Duck nesting success is enhanced by presence of nesting owls and resultant reduced starling competition; and, therefore, management should provide adequate numbers of nest sites for both owl and duck species.

The benefit of nestboxes to increase nesting success by reducing interspecific competition for nest sites is highlighted by the Puerto Rican Parrot (*Amazona vittata*) recovery program (Wiley 1980, Snyder and Taapken 1981). Competition with the parrots for nest cavities by the Pearly-eyed Thrasher (*Margarops fuscatus*) has been a serious limiting factor against population recovery by the parrot. Placement of optimally configured thrasher nestboxes near parrot boxes has diverted thrashers from the parrot nests; and the territorial thrashers protect the nest vicinity of both species by fending off intruding other pairs of thrashers.

Blowflies (Diptera: Calliphoridae) are common ectoparasites of cavity-nesting birds, and may limit nesting success by weakening or killing nestlings (Kenaga 1961). In Eastern Bluebirds in the Huron National Forest, Pinkowski (1977) found that blowflies (*Apaulina* sp.) parasitized natural cavities and nestboxes at comparable rates (85% and 82%, respectively). The difference in the mean number of parasites per loaded nest, however, was significant, with 51.5 in natural cavities, and 91.4 in nestboxes. The author explained that blowfly numbers are affected by the amount of grassnesting material available as blowfly habitat, and the larger size and square shape of boxes require the bluebird to add more grass to make a nest cup, thereby increasing the number of parasites in the nestbox. Therefore, box designs that conform to dimensions and shapes of natural cavities would be beneficial to bluebirds, as would management for more natural cavities available to the species.

Nestboxes provide amateur and professional ornithologists and conservationists with a convenient and essential tool for their work to understand and maintain populations of cavity-nesting birds. Direct and controllable access to the contents of a nest cavity, or to the contents of many nest cavities, permits evaluation of the success of both the nesting birds and our management effort. Flexibility of the design and placement of nest sites provides for limitless experimentation, and hence a greater insight to the relationships of the nesting bird and its physical and biological environment.

Nestboxes obviously do not replace natural cavities; and they cannot effectively mitigate for the loss of natural nest sites in avian habitat. The majority of box-oriented studies relates to specific geographical and ecological conditions surrounding a limited number of species; and replication of multiple-species communities using nestboxes in the absence of natural habitat is not possible. Nestbox programs of the large extent common in Europe and occasional in North America are, when properly monitored and maintained, expensive. Wildlife and forest managers require detailed biological and economic information for cost:benefit analysis decisions to integrate possible nestboxes into forest management programs for cavity-nesting birds.

If nestboxes are to be considered in a management program, it is recommended that planners take full advantage of the extensive and intensive literature and experience on the subject, a minor portion of which has been introduced in this paper.

## LITERATURE CITED

- Audubon, J.J. 1831. Ornithological biography. Vol. 1. Philadelphia.
- Balen, J.H. van, C.J.H. Booy, J.A. van Franeker, and E.R. Osiek. 1982. Studies on hole-nesting birds in natural cavities, 1. Availability and occupation of natural nest sites. *Ardea* 70: 1-24.
- Bellrose, F.C. 1976. The comeback of the Wood Duck. *Wildl. Soc. Bull.* 4: 107-110.
- Bellrose, F.C., K.L. Johnson, and T.U. Meyers. 1964. Relative value of natural cavities and nesting houses for Wood Ducks. *J. Wildl. Manage.* 28: 661-676.
- Bolen, E.G. 1967. Nesting boxes for Black-bellied Tree Ducks. *J. Wildl. Manage.* 31: 794-797.
- Catesby, M. 1731. The natural history of Carolina, Florida and the Bahama Islands. Vol. 1. London.
- Graczyk, R. 1974. Birds nesting in nesting boxes in pine stands with pine lappet moth (*Dendrolimus pini* L.) gradation in the Wyszyna Forest District. *Rocz. Akad. Rolniczej Poznan.* 45: 21-28.
- Graczyk, R., T. Galinski, and Z. Klejnotowski. 1970. The settlement density of birds nesting in boxes in the years 1967-1969 on the Przybroda Experimental Orchard terrain. *Rocz. Akad. Rolniczej Poznan.* 43: 27-35.

- Grenquist, P. 1953. On the nesting of the Goose-ander in bird-boxes. Suomen Riista 8: 49-59, 220-221.
- Haartman, L. von. 1971. in Farner and King (eds.), Avian biology. Vol. 1, chap. 9. New York.
- Hesselschwerdt, R.E. 1941. Large nest boxes: a new aid in the restoration program. Audubon Bull. (Chicago) 39: 1-6.
- Kibler, L.F. 1969. The establishment and maintenance of a bluebird nest-box project: a review and commentary. Bird-Banding 40: 114-129.
- Kenaga, E.E. 1961. Some insect parasites associated with the Eastern Bluebird in Michigan. Bird-Banding 32: 91-94.
- Kalmbach, E. 1939. Nesting success: its significance in waterfowl reproduction. Trans. No. Amer. Wildl. Conf. 4: 591-604.
- McAtee, W.L. 1940. An experiment in songbird management. Auk 57: 333-348.
- Musselman, T.E. 1934. Help the bluebirds. Bird-Lore 36: 9-13.
- Musselman, T.E. 1940. Increasing quail and bluebirds by two hundred and two thousand. Audubon Bull. (Chicago) 33: 1-4.
- Nilsson, S.G. 1975. Kullstorlek och häckningsfråmgång i holkar och naturliga hål. Vår Fågelv. 34: 207-211.
- Phillips, J.C. 1925. A natural history of the ducks. Vol. 3. Cambridge, Massachusetts.
- Poznanin, L.P. (ed.). 1956. Ways and means of using birds in combating noxious insects, Proc. Conf. 1953, 1954. Ministry Agriculture, USSR. (Israel Prog. Sci. Trans. 117).
- Perrins, C.M. 1980. The Great Tit, *Parus major*. Biologist 27: 73-80.
- Pinkowski, B.C. 1976. Use of tree cavities by nesting Eastern Bluebirds. J. Wildl. Manage. 40: 556-563.
- Pinkowski, B.C. 1977. Blowfly parasitism of Eastern Bluebirds in natural and artificial nest sites. J. Wildl. Manage. 41: 272-276.
- Sokolowski, J. 1931. Bird-protection in Poland. Bull. Int. Comm. Bird Preserv. 3: 32-36.
- Siren, M. 1951. Increasing the Goldeneye population with nest boxes. Suomen Riista 6: 83-101, 189-190.
- Strange, T.H., E.R. Cunningham, and J.W. Goertz. 1971. Use of nest boxes by Wood Ducks in Mississippi. J. Wildl. Manage. 35: 786-793.
- Snyder, N.F.R. and J.D. Taapken. 1981. Puerto Rican Parrots and nest predation by Pearly-eyed Thrashers. Avicult. Bull. (May): 14-16.
- VanCamp, L.F. and C.J. Henny. 1975. The Screech Owl: its life history and population ecology in northern Ohio. No. Amer. Fauna 71: 1-65.
- Wilson, A. 1831. American ornithology. Vol. 4. Edinburgh.
- Wolda, G. 1917. Vogelcultuur. Dept. van Landbouw, Nijverheid en Handel. Directie van den landbouw. pp. 1-27.
- Wiley, J.W. 1981. The Puerto Rican Parrot: (*Amazona vittata*): its decline and the program for its conservation. in R.F. Pasquier (ed.), Conservation of new world parrots. Proc. ICBP Parrot Working Group meeting, St. Lucia, 1980. pp. 133-159.



# Power Pole Damage by Acorn Woodpeckers in Southeastern Arizona<sup>1</sup>

G. Patrick O'Brien<sup>2</sup>

---

**Abstract.** Southeastern Arizona utility companies experience extensive damage to power poles by acorn woodpeckers (*Melanerpes formicivorus*). Woodpecker cavities existed in 54 percent of 266 power poles inspected and resulted in an average of 1.5 cavities per pole. The mean depth of 49 cavities was 31.8 cm and ranged from 15.2 cm to 54.6 cm. A single power pole was found to contain 5 cavities which resulted in a combined cavity depth of 168.3 cm.

---

## INTRODUCTION

The acorn woodpecker (*Melanerpes formicivorus*) inhabits oak and oak-pine woodlands in Oregon, California, Arizona, New Mexico and southward into Columbia (Dawson 1923, Ridgway 1914, Skutch 1969). In Arizona the species is a resident of oak and oak-pine belts throughout the state, with the exception of extreme northern portions (Phillips, Marshall and Monson 1964). Bock and Bock (1974) reported that populations in Arizona, New Mexico and Texas are considerably fewer than in Pacific regions due to a lack of oak species diversity. Acorn woodpeckers are socially communal during all periods of the year and exist in groups of 2-10 (Bent 1939, Dawson et al. 1923, Stacey 1979). All members of a group contribute to territorial and food defense, cavity construction and the care and feeding of young (McRoberts 1970).

Acorn woodpeckers are widely known for their unique habit of storing acorns in the cracks and crevices of trees, posts, and poles (Bailey 1928, Bent et al. 1939, Phillips, Marshall and Monson et al. 1964, Ritter 1938). The woodpecker creates small holes in trees, posts and poles where they force acorns for storage and such storage areas will often cover an entire branch or pole. Dawson (et al. 1923) observed a pine tree in California estimated to contain 50,000 imbedded acorns. Acorn storage areas in southeastern Arizona were found on the dead branches of walnuts, sycamores, cottonwoods, junipers and on power poles. Major foraging methods in Central America includes

gleaning, flycatching, sap feeding, acorn storage and probing (Stacey et al. 1979). Acorn woodpeckers are expert flycatchers and display amazing aerial acrobatics when pursuing winged insects. McRoberts (et al. 1970) reported the collection and storage of insects as being common during the nesting period. A woodpecker was observed to catch a flying insect, whereby it took it to a nearby power pole and immediately placed it in a narrow crevice. The insect was removed and relocated twice more before being left. Apparent sap holes have been observed in the trunks and branches of oak trees, although direct use of these sites was never noted. Even though acorn woodpeckers are known to consume ants, the importance of the insect and application of the name formicivorus (ant eating) is considered inappropriate, since ants constitute only an occasional portion of the diet (Dawson et al. 1923).

Nesting and roosting cavities of acorn woodpeckers are reported to exist in oaks, sycamores, pines, eucalyptus and power poles (Bailey et al. 1928, Dawson et al. 1923, Rumsey 1973, Skutch et al. 1969). Woodpecker cavities in the study area were observed in the branches and trunks of walnut, ash, cottonwood, juniper, willow, oak, sycamore and pine, as well as power poles.

Brant (1951) reported that of the 7 breeding woodpeckers in southeastern Arizona, the acorn woodpecker was the latest nester (peak in June). It appears that an undetermined segment of the population vacates southeastern Arizona during late winter and does not return until near the breeding season, although some groups remain throughout the year. The availability of vacant acorn woodpecker cavities allows for many earlier cavity nesting birds to use the sites. Suspected or observed nesters inhabiting acorn woodpecker cavities includes the elf owl (*Micrathene whitneyi*), flicker (*Colaptes cafer*), bluebird (*Sialia* sp.), kestrel (*Falco sparverius*) and coppery-tailed trogon (*Trogon elegans*). Of these species, only the trogon would possibly conflict

---

<sup>1</sup>Paper presented at the snag habitat management symposium (Flagstaff, Arizona, June 7-9, 1983).

<sup>2</sup>G. Patrick O'Brien is a Wildlife Manager with the Arizona Game and Fish Department, Sierra Vista, Arizona.



with the nesting period of the acorn woodpecker.

Woodpecker damage to power poles is known to occur throughout the southern, southwestern, southeastern and northeastern portions of the United States and into Central America (Rumsey et al. 1973, Skutch et al. 1969). Rumsey (et al. 1973) listed pole damaging species to include the pileated (*Hylatomus pileatus*), red-headed (*Melanerpes erythrocephalus*), ladder-backed (*Dendrocopos scalaris*) and golden-fronted (*Centurus aurifrons*) woodpeckers. The acorn woodpecker must certainly be added to this list and it is also possible that other species either contribute to or receive blame for pole damage. For instance, it is common to observe flickers on damaged power poles, although I have never observed them pecking on them.

Utility companies experiencing woodpecker damaged poles have tried a variety of methods in alleviating the problem. Such efforts have involved the shooting of offenders, the use of fiberglass and cement poles, protective plastic and wire meshing, offensive chemicals and simulated snakes attached to poles (Benton 1966). Where severely damaged poles have been replaced, the damaged pole has often been left in an effort to eliminate damage to the new pole.

The southeastern Arizona based Sulphur Springs Valley Electric Power Cooperative has long expressed a concern with woodpecker damage to power poles and concedes that their damage is undoubtedly less than other areas. Even though damage by ladder-backed woodpeckers is known to exist in the area, the major problem involves the acorn woodpecker. From 1978 to 1982 the power cooperative replaced 74 utility poles specifically related to woodpecker damage. Numerous other pole replacements involving woodpecker damage occurred during this period, but were not replaced specifically for that purpose. Damage involved numerous partial holes, riddled cross-arms, deeply penetrated pole tops and cavities. Even though the 74 woodpecker damaged pole replacements represented less than 1 percent of about 10,000 poles examined during the period, severely damaged poles were unusually concentrated in localized problem areas. For example, 3 individual poles were replaced a combined total of 7 times during the 5 year period and even when the damaged pole was left standing, woodpecker damage continued to occur on the new poles.

Power pole replacement in itself is expensive and is compounded by the fact that woodpecker damage severely reduces pole longevity. Increased expenditures for pole purchases, labor, materials, gasoline, paperwork and accounting due to such damage is certainly reason for concern. A typical example of replacement costs due to woodpeckers is illustrated by the following case in-point. The Sulphur Springs Valley Cooperative received a call from a service member concerning woodpecker damage to a power pole near his residence. The area superintendant dispatched a service crew to inspect the complaint and they recommended immediate pole replacement due to woodpecker damage. The following day a small line crew and hot-line crew drove

1 hour to the site and spent 4 hours replacing the pole without interrupting power to customers. The total cost for replacement of the single pole was \$1294.12. If this figure is multiplied by the 74 poles replaced to woodpecker damage over the 5 year period, the added cost to consumers was \$95,764.88.

#### STUDY AREA - METHODS

The study area was confined to portions of Cochise and Santa Cruz Counties in extreme southeastern Arizona. Major tree species included Emory oaks (*Quercus emoryi*) and alligator juniper (*Juniperus deppeana*), with lesser amounts of white oak (*Q. arizonica*), Mexican blue oak (*Q. oblongifolia*), netleaf oak (*Q. reticulata*), silverleak oak (*Q. hypoleucoides*), Toumey oak (*Q. Toumeyi*) and Palmer oak (*Q. chrysolepis*). Drainages contained walnut (*Juglans major*), Ash (*Fraxinus velutina*), cottonwood (*Populus fremontii*), willow (*Salix sp.*), sycamore (*Platanus wrightii*) and Chihuahua pine (*Pinus leiophylla*).

Seven survey routes involving 30.6 km were conducted in the study area. The shortest route was 0.4 km and the longest was 9.4 km. Pole inspection involved driving the survey route where woodpecker cavities, exposure, height, line direction, and observed acorn woodpeckers were recorded. The number of cavities observed were considered a minimum since only 3 sides of a pole were usually observed. Tree cavities observed in the study area were recorded for a comparison of use and availability. A limited number of tree and pole cavities were measured with reference to entrance width and cavity depth. Power pole measurements involved the use of utility company linemen.

#### FINDINGS

Two hundred and sixty-six power poles were inspected along 30.6 km of survey route and involved 144 (54%) woodpecker damaged poles (Table I). The greatest intensity (85%) of cavity poles on an individual route involved 69 of 81 poles. The total number of cavities observed on cavity poles was 211 and averaged 1.5 per pole. Cavities per pole on individual routes varied from 1.0 to 2.1 and the total number of acorn woodpeckers observed during surveys was 73 (mean 3.8/km).

Table I. Woodpecker damage observed along survey routes.

Survey distance (km)	30.6
No. poles inspected	266
No. cavities observed	211
No. cavity poles	144
Cavities/pole	1.5
No. acorn woodpeckers	73
Woodpeckers/km	3.8

Acorn woodpeckers were observed perched on most points of power poles including the top,



sides, cross-arms, and occasionally wires. Wire perching was very uncommon and was observed only 2-3 times. Other than wires, no perching was ever observed on attached equipment such as transformers, bolts and insulators. Pole top and cross-arm perching occurred mostly during aerial feeding and food ingestion. Vertical pole perching was the most common overall activity and usually involved the upper one-third of the pole. During hot summer months, woodpeckers would often rotate on the pole so as to remain in the shade.

A slightly greater number of woodpecker cavities were observed to exist below the point of attached wires or cross-arms (Table II). Since attached wires and cross-arms are usually near the top of poles, a greater area for cavity construction lies below this point. Pole cavities varied from the extreme top to as low as 5 feet above the ground. In general, most cavity construction existed above the pole mid-point.

Woodpecker cavity entrances on poles were aligned with attached wires during 75 percent of all observations (Table II). Some bias undoubtedly exist in this data since vehicular transects always ran parallel to wire direction and because of this, all exposures of in-line cavities were observable, while only one non-lined side was visible. Gila woodpecker (*Melanerpes uropygialis*) cavities in saguaro cactus revealed a mean (351°) orientation of near north, even though all exposures were used (Inouye, Huntly and Inouye 1981). Entrance exposures for cactus wrens (*Camphylorhynchus brunneicapillus*) are shown to change for radiation control during summer and winter months (Ricklefs & Hainsworth 1968) and woodpecker holes in Colorado aspen trees faced direction of maximum radiation (Inouye 1976). Data from Soule (1964) revealed that the summer temperatures within a cavity nest was influenced by the direction of orientation of the entrance. The outside shade temperature adjacent to a pole cavity at 1100 hours on June 6 was 90°F, while the temperature inside a north facing cavity was 86°F. At 1430 hours, the outside temperature had risen to 98°F and the cavity temperature to 93°F. This particular pole contained both north and south facing cavities which were used by woodpeckers. It is possible that multiple cavity exposures on an individual pole allows for thermoregulation during the varying seasons.

Table II. Power pole cavity entrance alignment

	<u>Number</u>	<u>Percent</u>
Above wire	108	46
Below wire	127	54
In-line	149	75
Non-lined	50	25
North	69	32
South	49	23
East	50	23
West	48	22

The extent of damage by woodpeckers to power poles is evidenced by the number and size of cavities, cross-arm damage and pole pecking. Forty-nine pole cavities were measured which contained a mean cavity entrance of 6.9 cm. and a mean vertical depth of 31.8 cm. Ten tree cavities in the study area were measured for comparison and were slightly smaller than pole cavities (Table II). The increased size of pole cavity entrance and depth indicates the ease of wood removal in soft pine poles. Cavity entrance measurements were slightly greater on the vertical than the horizontal, although it was not as exaggerated in tree cavities. A limited number of measurements of the width of pole cavities ranged from 11.4 cm to 16.5 cm. The pole diameter at one cavity was measured at 22.9 cm. while the cavity itself was 16.5 cm. Power pole strength is undoubtedly reduced where such large cavities occur. Many poles contained entrance holes that penetrated vertically for only a few centimeters (15-55 cm) and were not considered cavities suitable for woodpecker nesting. It was assumed that these holes were either in the development stage or were abandoned prior to completion. Such holes were commonly observed on both cavity and non-cavity poles.

Table III. Comparative measurements of pole and tree cavities.

	<u>Sample</u>	<u>Entrance</u>	<u>Depth (cm)</u>
Poles	49	6.9	31.8
Trees	10	5.6	28.2

Inasmuch as cavity poles in the study area averaged 1.5 cavities per pole, most poles contained multiple cavities. The greatest number of cavities found on a single pole was 5 and measured a combined vertical depth of 163.8 cm. Another pole, with an attached transformer, contained a single cavity with both north and south exposed entrances. The safety strength of this pole was greatly reduced since the cavity existed below the transformer. This was the only pole cavity found to possess double entrances. In addition to the aforementioned partial cavities, numerous entrance holes were observed which did not extend vertically and only penetrated the pole for about 8 cm. Numerous smaller holes were observed on both cavity and non-cavity poles and ranged in size from acorn storage size to larger. The majority of these were located on the upper one-quarter of the pole and were generally more numerous on cavity poles.

In an attempt to make some comparison of the use of trees and power poles by woodpeckers in the study area, 104 trees were observed to contain 192 cavities (1.9 cavities/tree). All tree cavities were found to exist in the dead branches of live trees or in dead trees. The only exception to this occurred in walnuts, where a limited number of cavities were found in live branches. Eight tree species were found to contain woodpecker cavities and the use of individual species was found to vary greatly (Table IV). Walnuts and pines comprised the greatest cavity use (53%) and



were followed by sycamore, cottonwood and oaks (39%). Juniper, ash and willow contained only 11 percent of the observed tree cavities. Walnut and pine trees were limited in the study area and were confined primarily to drainages, as were sycamores, cottonwoods, ash and willows. Oaks and junipers were widespread and abundant. Although cottonwoods were fourth on the list of tree species used by woodpeckers, cavities per tree was the greatest (2.8/tree) and is possibly explained by the fact that cottonwoods offered a greater number of dead branches. Chihuahua pines were abundant in an isolated area near the Cochise-Santa Cruz County line where telephone poles were also available. The incidence of pole damage in this area was minor considering the number of acorn woodpeckers inhabiting the area. A high incidence of use on dead Chihuahua pines occurred in this area. During the study the telephone line was being replaced underground and the poles removed. Upon removal of a pole known to contain an active woodpecker cavity, acorn woodpeckers were observed constructing a cavity in a previously uninhabited dead pine close by.

Table IV. Tree cavities observed in study area.

Species	#Trees	#Cavities	Cavities/Tree
Walnut	28	51	1.8
Pine	27	50	1.9
Sycamore	17	27	1.6
Cottonwood	12	34	2.8
Oak	11	17	1.5
Juniper	6	7	1.2
Ash	2	3	1.5
Willow	1	3	3.0
	104	192	1.9

#### CONCLUSIONS

Power pole damage by acorn woodpeckers is an expensive problem to utility companies in southeastern Arizona. Major damage exists in the form of cavity construction and cross-arm or pole pecking. Although the extent of damage varies by area, the expenses incurred by such damage is reason for concern. Utility companies have long sought answers to the problem and continue to seek methods of eliminating undue pole replacement, potential safety hazards, power outages and other inconveniences created by woodpecker damage.

Although the precise reasons for woodpecker use of power poles is unknown, several theories can be offered for explanation. It is most likely that the mere presence of soft pine poles in acorn woodpecker habitat offers them for use. However, other factors influencing the variance in intensity of use must be considered before seeking a solution to the problem.

Power lines throughout acorn woodpecker habitat in southeastern Arizona usually traverse riparian bottoms and oak woodland areas. It is felt that relatively pure stands of oak-juniper woodlands offer limited cavity sites for acorn woodpeckers when compared to riparian tree species or power poles. This is possibly due to the

hardness of oak and juniper woods and the limited availability of snags they offer. Riparian bottoms involving soft wood species such as walnut, sycamore and cottonwood are usually coincidental with the presence of power poles. That is to say that power lines traverse the habitat along wide bottoms and lightly wooded areas. Acorn woodpecker populations appear to be greatest in areas involving open woodland or riparian bottoms and in such areas the population may actually exceed the availability of natural tree cavity sites. Large dead branches of desired soft trees are continually breaking off or falling down and are no longer available for use. Power poles, on the other hand, are more stable and do not involve the undesired entanglement of numerous branches. The only exception to extensive power pole use in this study occurred in a single area where numerous dead pines were available for woodpecker use and power pole damage was light.

Since acorn woodpeckers show a preference for more open woodlands or bottoms, densely wooded areas contain limited populations. Transect number II of this study involved a wide riparian bottom with numerous sycamore, walnut and cottonwood trees. Adjacent hillsides contained light to moderate stands of oak and juniper. Of the 7 transect areas included in this study, it was estimated that this particular route (9.4 km) provided the best habitat for acorn woodpeckers. This was based on the availability of cavity trees and the number of woodpeckers observed per kilometer (4.7). Power pole damage on the other hand was the greatest of any route (85%). It may be that the woodpecker population actually overwhelmed the availability of natural cavity sites and therefore exerted increased use of power poles. However, it is not actually known whether native trees or power poles are the more preferred site and it may be that a combination of both enhances woodpecker populations. A removal of all power poles would probably affect woodpecker densities in most areas. There are sites where it is felt that power poles are the prime factor in influencing the density of acorn woodpeckers and without their presence, populations would be reduced.

In an effort to test alternate cavity sites along power lines, a 1.8 km route involving 14 poles was selected. Seven poles were found to contain a total of 15 cavities and involved approximately 8 resident acorn woodpeckers. Wooden boxes were designed to simulate cavities and were erected on cavity poles. Pole cavity entrances were blocked by placing a metal plate over the hole to eliminate use. Four of the 7 wooden boxes were observed to house acorn woodpeckers within 2 months of installation. However, woodpeckers retained a desire to use old cavities and created new entrances beside the plates on 4 occasions. One particular pole contained both north and south facing cavities which were simultaneously blocked from entry. Both cavities were eventually re-entered by woodpeckers below the plates and were blocked again. The south facing cavity was again re-entered and blocked for a third time. Acorn woodpeckers were observed using the box during the time of pole cavity re-entry.



The results of this limited study certainly lends credence to the fact that acorn woodpeckers inflict damage on power poles. Although the overall importance of power poles to population densities is uncertain, they are considered significant in many areas. The solution of how best to combat the problem inflicted on utility companies without adversely affecting woodpecker populations is yet to be determined. Cavity boxes may provide a partial solution, but it is doubtful that they will supplant the natural desire of woodpeckers to excavate. This is validated by the fact that many multiple cavity poles and trees exist, even though some pole cavities are completely unoccupied. Undoubtedly, biological ingenuity and the determination of utility companies will find a solution to the problem.

Acknowledgements. - I would like to extend my thanks to the many Sulphur Springs Valley Electric Cooperative personnel who assisted in the project. A very special thanks to Pete Swiatek who graciously erected boxes and measured pole cavities. Additional gratitude to Dave Drew for compiling information on damaged pole costs and to Barbie Reichel for continuous typing of the manuscript.

#### LITERATURE CITED

- Bailey, F.M. 1928. Birds of New Mexico. New Mexico Game and Fish. Santa Fe.
- Baird, S.F., T.M. Brewer and R. Ridgway. 1874. A history of North American birds, Little, Brown and Co., Vol. 2.
- Bent, A.C. 1939. Life history of North American woodpeckers. U.S. Natl. Mus. Bull. 174.
- Bock, C.E. and J.H. Bock 1974. Geographical ecology of the acorn woodpecker; diversity versus abundance of resources. Am. Natl. 108:694-696.
- Brandt, Herbert 1951. Arizona and its bird life. Bird Research Foundation.
- Dawson, W.L. 1923. The birds of California. Vol. 2. p. 1024-1029.
- Inouye, D.W. 1976. Non-random orientation of entrance holes to woodpecker nests in aspen trees. Condor 78:101-102.
- Inouye, Richard S., Nancy J. Huntly and David W. Inouye 1981. Non-random orientation of Gila woodpecker nest entrances in saguaro cactus. Condor 83:88-89.
- McRoberts, Michael H. 1970. Notes on the food habits and food defense of the acorn woodpecker. Condor 72:196-204.
- Phillips, Allan, Joe Marshall and Gale Monson 1964. The Birds of Arizona. Univ. of Arizona Press, Tucson.
- Ricklefs, R.E. and F.R. Hainsworth 1968. Temperature dependant behavior of the cactus wren. Ecology 49:227-232.
- Ridgway, R. 1914. The Birds of North and Middle America. U.S. Natl. Mus. Bull. No. 50.
- Ritter, W.E. 1938. The California woodpecker and I. Univ. California Press, Berkley.
- Rumsey, Robert Louis. 1973. Woodpecker damage to wooden utility poles. PhD thesis, LA State Univ.
- Soule, O. 1964. The saguaro tree-hole microenvironment in southeastern Arizona. II. Summer M.S. Thesis Univ. Arizona, Tucson.
- Skutch, A.F. 1969. Life histories of Central American birds, III, Pacific Coast Avifauna 35.
- Stacey, Peter B. 1979. Habitat saturation and communal breeding in the acorn woodpecker. An. Behav. 27:1153-1166.
- \_\_\_\_\_ 1981. Foraging behavior of the acorn woodpecker in Belize, Central America. Condor 83:336-339.



# Cavity-Nesting Bird Requirements and Response to Snag Cutting in Ponderosa Pine<sup>1</sup>

Virgil E. Scott and John L. Oldemeyer<sup>1</sup>

---

Abstract.--Cavity-nesting bird densities declined 53% when conifer snags were removed during a timber harvest on the Apache-Sitgreaves National Forest in Arizona. On an adjacent cutover area where snags were left standing the cavity-nesting bird population increased 25%. Cavity-nesting bird densities on an unharvested control plot increased 32%. Birds that nested in ponderosa pine snags were affected most by snag removal. Violet-green swallows<sup>2</sup> declined from 41 to 4 birds/100 acres after snags were removed and pygmy nuthatches declined from 32 to 15/100 acres. Two species responded significantly to the reduction in basal area: white-breasted nuthatches decreased and house wrens increased.

For nesting sites, cavity-nesting birds usually selected ponderosa pine (Pinus ponderosa) snags that were greater than 18 inches diameter breast high (dbh), dead 6 years and with at least 40% bark cover.

---

## INTRODUCTION

Snags serve in a variety of ways as wildlife habitat. Cavities made by primary cavity nesters (those birds that excavate their own holes) provide nests and denning sites for secondary cavity users (those that nest in cavities but are unable to excavate holes) such as bats, squirrels, and several birds (Thomas et al. 1979). Snags are used by raptors, flycatching birds, and band-tailed pigeons (Columba fasciata) for such activities as hunting, feeding, loafing, or roosting (Scott et al. 1980). Invertebrates living in the dead wood and under bark provide food for some of the woodpeckers.

It has been shown that snags with heartrot (Fomes sp.) are selected by primary cavity-nesting birds for excavating nest holes (McClelland and Frissel 1975, Miller and Miller 1980), and that larger snags are used more frequently than smaller

snags (Bull 1975, Gale 1973, McClelland and Frissel 1975, Thomas et al. 1979). Mannan et al. (1980) reported that the density of hole-nesting birds was positively correlated with the mean dbh of snags on their study area in western Oregon. However, no general statement can be made for all birds since size of snags used for nest hole excavation varies with tree and bird species (Bull et al. 1980, Lanning and Shiflett 1983, Mannan et al. 1980, McClelland et al. 1979, and Scott et al. 1980). This report summarizes the characteristics of snags used by cavity-nesting birds in a forest dominated by ponderosa pine in Arizona and the response of birds to snag removal.

## STUDY LOCATION AND METHODS

The 124-acre study area was in an oldgrowth ponderosa pine forest five miles west of Greer, Arizona, on the Apache-Sitgreaves National Forest. Ponderosa pine accounted for 83% of the tree stand which also contained Douglas-fir (Pseudotsuga menziesii) and limber pine (Pinus flexilis). Several small aspen (Populus tremuloides) clones were interspersed throughout the stand. The study area was divided into three plots. Plots A and B were selectively harvested; snags were cut on Plot A but not on Plot B. Plot C served as an uncut control. Eight bird surveys were conducted on each plot between 20 May and 30 June for 2 years before harvest and 2 years after

---

<sup>1</sup> Virgil E. Scott and John L. Oldemeyer are wildlife biologists (research), U.S. Fish and Wildlife Service, Denver Wildlife Research Center, stationed at Fort Collins, Colorado.

<sup>2</sup> Bird nomenclature follows the Thirty-fourth Supplement to the American Ornithologists' Union Checklist of North American Birds. Supplement to the Auk. Vol 99, No. 3, July 1982 and scientific names appear in Table 1.



harvest. Bird densities were determined by the spot map method (Kendeigh 1944) and compared by analysis of variance.

Basal area of live trees  $\geq$  five inches dbh was determined by the plotless method (Grosenbaugh 1952). Trees were harvested in late summer and fall 1974 after bird surveys were completed. All conifer snags on the study area were measured and examined for use by cavity-nesting birds before timber harvest occurred.

## RESULTS AND DISCUSSION

Basal area of live trees  $\geq$  five inches dbh before timber removal was 110, 107, and 102 feet<sup>2</sup>/acre on Plots A, B, and C respectively (Scott 1979). Post harvest basal area on A and B was 51 and 64 feet<sup>2</sup>/acre respectively. Basal area in Plot C was unchanged.

There were 4.6 conifer snags/acre  $\geq$  7 inches dbh in Plot A before harvest and all were cut during timber harvest and most were left on the ground. After timber harvest 14 aspen snags  $\geq$  5 inches dbh (0.3/ac) remained. On Plot B there were 6.1 conifer snags/acre before harvest. Some snags were accidentally knocked down during timber harvest and some were blown over; 4.1 conifer snags/acre remained. After timber harvest 29 aspen snags  $\geq$  5 inches dbh (0.8/ac) remained on Plot B. Plot C had 4.0 conifer snags/acre in 1973 and 3.6 in 1976; no aspen snags  $\geq$  5 inches dbh occurred in Plot C.

Birds usually selected ponderosa pine snags greater than 18 inches dbh, those had been dead  $\geq$  6 years, and those with at least 40% bark cover for nest sites and 71% of the snags meeting these criteria had holes made by cavity nesters. Twelve percent of the snags  $\geq$  8 inches dbh and dead  $\leq$  5 years had holes whereas 62% of those dead  $\geq$  6 years had been used by cavity-nesting birds. Nearly all of the cavity nests found in ponderosa pine were in snags. Those cavity nests found in living trees were in dead portions of the tree (ie. dead tops or a dead strip resulting from lightning strikes). Larger snags tended to have more holes and were used more frequently than smaller snags. Tall snags ( $>$ 45 feet) were used at about the same frequency as shorter ones ( $<$ 45 feet) but more holes were present in the taller snags. There were 2.6 snags/acre with cavities and 75% of the snags containing cavities were  $\geq$  19 inches dbh. Holes were present in 28% of snags  $<$  19 inches dbh and 54% of those  $\geq$  19 inches.

Densities of all birds before harvest ranged from 225/100 acres on Plot C to 303/100 acres on Plot B (table 1) and were not different ( $P < 0.05$ ) among plots. Within treatments, the posttreatment bird densities were not different from pretreatment. Density of foliage-nesting birds did not change after harvest. Ground-nesting birds increased on all plots but the percentage increase was least on the Plot C. Most of the numerical

increase in ground nesting birds was related to reduction in basal area on Plots A and B.

Density of cavity-nesting birds was 53% lower on Plot A after timber harvest whereas density increased on Plots B and C. Some bird species within the cavity-nesting guild responded independently but the overall response in density was positively correlated ( $r=0.72$ ) to the number of snags in the plots.

Some birds occurred in numbers too small or in too few plots and no inferences could be made about the effect of timber harvest on their density (i.e., American kestrels, yellow-bellied sapsuckers, downy woodpeckers, hairy woodpeckers, three-toed woodpeckers, brown creepers, and mountain bluebirds). We found nests of American kestrels, three-toed woodpeckers, and violet-green swallows only in ponderosa pine snags; whereas, nests of Williamson's sapsuckers and hairy and downy woodpeckers were found only in aspen. Scott et al. (1980) reported violet-green swallows nesting in both aspen and conifer snags. We also found northern flickers, mountain chickadees, and white-breasted nuthatches nesting in aspen and ponderosa pine snags. One pygmy nuthatch was observed nesting in an aspen snag on Plot A after snag removal.

Densities of three species did not respond with timber harvest: Williamson's sapsuckers, mountain chickadees, and western bluebirds (table 1). Greatest densities of Williamson's sapsuckers were found in the control plot both before and after harvest, and densities were somewhat lower in all plots after harvest. Mountain chickadees responded in a similar manner, whereas western bluebirds increased slightly, but not significantly so, after harvest in all plots. The remaining aspen (trees and snags) probably provided nesting habitat for these species. We observed one pair each of pygmy nuthatch, Williamson's sapsucker, and western bluebird nesting in one aspen snag on Plot A after timber harvest. Western bluebirds usually nest near openings or in more open woodlands and the timber harvest created this type of habitat.

Two species responded significantly to the reduction of basal area (table 2). White-breasted nuthatches decreased significantly in Plots A and B, where post-harvest density averaged 20% of the pre-harvest density. Density of western flycatchers followed a similar, though non-significant, pattern to white-breasted nuthatches. Although white-breasted nuthatches are cavity nesters, their decrease was probably due to the decrease in standing timber. House wrens, on the other hand, increased in Plots A and B after harvest where its post-harvest density averaged 222% greater than pre-harvest density. This increase was probably due to the increase in slash piles or brush found in the cutover areas.

Three species decreased significantly on Plot A with the reduction in snag density (table 2); northern flicker, violet-green swallow, and pygmy



Table 1.--Number of cavity-nesting birds/100 acres in a ponderosa pine study area before and after timber harvest. Densities are means of surveys conducted 2 years before and 2 years after timber harvest. Comparisons were made by ANOVA (NE = not examined, NS = non-significant, S = significant  $P \leq 0.05$ ).

	Results of ANOVA	Plot A Timber Harvested Snags Cut		Plot B Timber Harvested Snag Left		Plot C Timber Not Harvested	
		Before	After	Before	After	Before	After
American kestrel ( <i>Falco sparverius</i> )	NE		<1	3	5	0	0
Yellow-bellied sapsucker ( <i>Sphyrapicus varius</i> )	NE	2	<1	3	3	0	0
Williamson's sapsucker ( <i>S. thyroideus</i> )	NS	9	4	8	5	10	7
Downy woodpecker ( <i>Picoides pubescens</i> )	NE	0	2	1	0	1	<1
Hairy woodpecker ( <i>P. villosus</i> )	NS	5	3	<1	4	2	7
Three-toed woodpecker ( <i>P. tridactylus</i> )	NE	3	<1	3	3	2	<1
Northern flicker ( <i>Colaptes auratus</i> )	S	10	5	9	12	11	15
Western flycatcher ( <i>Empidonax difficilis</i> )	S	7	2	11	8	10	10
Violet-green swallow ( <i>Tachycineta thalassina</i> )	S	41	4	50	77	29	46
Mountain chickadee ( <i>Parus gambeli</i> )	NS	11	9	14	11	15	10
White-breasted nuthatch ( <i>Sitta carolinensis</i> )	S	7	2	8	<1	10	7
Pygmy nuthatch ( <i>S. pygmaea</i> )	S	32	15	37	45	27	40
Brown creeper ( <i>Certhia americana</i> )	NE	2	1	5	<1	0	7
House wren ( <i>Troglodytes aedon</i> )	S	8	11	1	18	0	<1
Western bluebird ( <i>Sialia mexicana</i> )	NS	2	5	5	7	2	5
Mountain bluebird ( <i>S. currucoides</i> )	NE	<1	2	9	11	0	3
Cavity nesters	S	139	66	167	209	119	157
Foliage nesters	NS	105	83	98	129	81	79
Ground nesters	S	31	51	38	67	25	48
Total Birds	S	275	200	303	405	225	284

Table 2.--Density of birds (number/100 ac) related to basal area and to snag density in a ponderosa pine forest in Arizona. Contrasts based on Scheffes' procedure.

	Density related to basal area		Density related to snag density	
	Plots A, B, and C before harvest and C after harvest (high basal area)	Plots A and B after harvest (low basal area)	Plot A after harvest (snags removal)	Plots B and C after harvest (snags not removed)
Northern flicker	11.3	8.5	5.0	13.5 *
Western flycatcher	9.5	5.0	2.0	9.0
Violet-green swallow	41.5	40.5	4.0	61.5 *
Mountain chickadee	12.5	10.0	9.0	10.5
White-breasted nuthatch	8.0	1.5 *	2.0	4.0
Pygmy nuthatch	34.0	30.0	15.0	42.5 *
House wren	2.5	14.5 *	11.0	9.5
Western bluebird	3.5	6.0	5.0	6.0
Cavity nesters	145.5	137.5	66.0	183.0 *
Foliage nesters	90.8	106.0	83.0	104.0
Ground nesters	35.5	59.0	51.0	57.5

\* Probability of observing differences in means of this magnitude were  $\leq 0.05\%$ .

nuthatch. Violet-green swallows and pygmy nuthatches depended heavily on ponderosa snags for nest sites. No other species followed an increasing or decreasing trend that seemed related to removal of snags; however, the cavity nesting guild decreased significantly when the density in Plot A (with snag removal) was compared to the post-harvest densities of Plots B and C. Cavity-nesting birds were affected by removals of conifer snags on Plot A although there were 0.3 aspen snags/acre  $\geq 5$  inches after timber harvest. Those birds that nested in ponderosa pine snags before harvest (violet-green swallows, pygmy nuthatches, and three-toed woodpeckers) were most affected by snag removal.

#### MANAGEMENT SUGGESTIONS

Cavity-nesting bird nest site requirements vary with the species since the larger birds physically require larger snags for hole excavation than do the smaller birds. Bull and Meslow (1977) suggested that snags  $\geq 20$  inches dbh should be retained for pileated woodpeckers (*Dryocopus pileatus*). Smaller birds, such as chickadees (*Parus* sp.), can use snags as small as six inches dbh (Scott et al. 1980).

Balda (1975) suggested that 2.7 snags/acre are necessary to maintain maximum densities and natural species diversity of secondary cavity nesters in the ponderosa pine forest. Cunningham et al. (1980) found that 2.1 snags/acre might be sufficient for secondary cavity nesters at natural levels. We found evidence of cavity nesting or roosting in 2.6 snags/acre in this uncut ponderosa pine forest which should have been at natural levels. Cunningham et al. (1980) reported that 75% of the nests located were in snags greater

than 23 inches dbh. We found that 75% of the snags with holes were  $\geq 19$  inches dbh. Holes were present in 28% of the snags  $\leq 18$  inches dbh whereas 54% of those snags  $\geq 19$  inches dbh had holes. For those snags that had been used by birds, the larger snags also had more holes/snag (3.8) than the smaller snags (2.8). Larger snags also remain standing longer than smaller snags (Cline 1977). If two to three snags/acre are accepted as a management goal in the ponderosa pine type, then all should be  $\geq 19$  inches dbh in order to fulfill the cavity-nesting bird's requirements. Trees with dead tops or dead portions in the trunk provide nesting sites for cavity nesters and if retained in the forest, can provide cavity nesting opportunities over a long period of time.

#### Literature Cited

- Balda, Russell P. 1975. The relationship of secondary cavity-nesters to snag densities in western coniferous forests. USDA. For. Serv., Southwest Reg. Wildl. Habitat Tech. Bull. 1, Albuquerque, NM, 37 p.
- Bull, Evelyn Louise. 1975. Habitat utilization of the pileated woodpecker, Blue Mountains, Oregon. M.S. Thesis, Ore. State Univ., Corvallis, 58 p.
- Bull, Evelyn L., Asa D. Twombly, and Thomas M. Quigley. 1980. Perpetuating snags in managed mixed conifer forests of the Blue Mountains, Oregon. Pp 325-336 in R.M. DeGraff and N.G. Tilgham, eds. Management of western forests and grasslands for nongame birds. USDA For. Serv. Gen. Tech. Report, Intermt. For. and Range Exp. Stn. Ogden, Utah. 535 p.



- Bull, Evelyn L. and E. Charles Meslow. 1977. Habitat requirements of the pileated woodpecker in northeastern Oregon. *J. Forestry* 77(6):335-337.
- Cline, Steven Paul. 1977. The characteristics and dynamics of snags in the Douglas-fir forests of the Oregon coast range. M.S. thesis. Oregon State Univ., Corvallis, 106 p.
- Cunningham, James B., Russell P. Balda, and William S. Gaud. 1980. Selection and use of snag by secondary cavity-nesting birds of the ponderosa pine forest. USDA. For. Serv. Res. Pap. RM-222. Rocky Mountain For. and Range Exp. Stn., Fort Collins, 15 p.
- Gale, Robert M. 1973. Snags, chainsaws and wildlife: one aspect of habitat management. 1973 Cal-Neva Wildl. Trans.:97-111.
- Grosenbaugh, L. R. 1952. Plotless timber estimates - new, fast, easy. *J. For.* 50:32-37.
- Kendeigh, S. Charles. 1944. Measurements of bird populations. *Ecol. Monog.* 14:67-106.
- Lanning, Dirk V., and James T. Shiflett. 1983. Nesting Ecology of thick-billed parrots. *Condor* 85:66-73.
- Mannan, R. William, E. Charles Meslow, and Howard M. Wright. 1980. Use of snags by birds in Douglas-fir forests, western Oregon. *J. Wildl. Manage.* 44(4):787-797.
- McClelland, B. Riley, and Sidney S. Frissell. 1975. Identifying forest snags useful for hole-nesting birds. *J. For.* 73(1):414-417.
- McClelland, B. Riley, Sidney S. Frissell, William C. Fisher and Curtis H. Halvorson. 1979. Habitat management for hole-nesting birds in forests of western larch and Douglas-fir. *J. For.* 77(8):480-483.
- Miller, Eileen, and Donald R. Miller. 1980. Snag use by birds. Pp. 337-356 in R.M. DeGraff and N.G. Tilgham, eds. Management of western forests and grasslands for nongame birds. USDA For. Serv. Gen. Tech. Report. Intermt. For. and Range Exp. Stn. Ogden, UT. 535 p.
- Scott, Virgil E. 1979. Bird response to snag removal in ponderosa pine. *J. For.* 77(1):26-28.
- Scott, Virgil E., Jill A. Whelan, and Peggy L. Svoboda. 1980. Cavity-nesting birds and forest management. Pp 311-324 in R.M. DeGraff, and N.G. Tilgham, eds. Management of western forests and grasslands for nongame birds. USDA For. Serv. Gen. Tech. Report. Intermt. For. and Range Exp. Stn., Ogden, Utah. 535 p.
- Thomas, Jack Ward, Ralph G. Anderson, Chris Maser, and Evelyn L. Bull. 1979. Snags. Pp 60-77 in J.W. Thomas, ed. Wildlife habitats in managed forests--the Blue Mountains of Oregon and Washington. USDA For. Serv., Agric. Handb. No. 553. US Print. Off., Wash., D.C. 512 p.





# Problems in Snag Management Implementation — A Case Study<sup>1</sup>

Edward W. Styskel<sup>2</sup>

---

Abstract.--Providing suitable snags over time for dependent wildlife within intensively managed forests is an extremely complex task. Problems encountered in achieving this goal include: (1) moderate responsiveness by accountable personnel; (2) determining and following snag status; (3) minimizing timber yield reductions; (4) imprecise "longevity" data for standing snags; and (5) protecting snags and live replacements from natural and man-caused loss. Techniques used to overcome some of these obstacles are discussed.

---

## INTRODUCTION

Efforts to intensively manage commercial forest land of National Forests in the western United States on an "even-aged" basis have made complex the task of providing suitable snags over time for dependent wildlife. Specifically, plans for the Deschutes National Forest in central Oregon have scheduled lodgepole pine, ponderosa pine, and mixed conifer forest stands for conversion to intensive timber management within 20, 40, and 50 years, respectively. Furthermore, rotation ages for these stands will be relatively short, at approximately 80, 135, and 120 years.

Snag management goals for the Forest have been established based on the concept of "maximum potential population" offered by Thomas, et al. (1979). Obstacles in achieving these goals have been numerous and difficult. Some have been surmounted; others are still unresolved.

This paper reports on what problems have been encountered (thus, could be expected by others implementing snag management), and how some were concluded.

## PROBLEMS

The transition from establishment of policy concerning the management of snags, first set forth on the Forest in 1973, to implementation on-the-ground has been slow but steady. First

efforts concentrated on protecting existing snags. Then, additional attention was given to reserving some live trees for future snag replacements. Now, systematic calculation of the number and size of live trees for snag replacements over a managed forest stand rotation is undertaken, based upon growth predictions and estimated snag standing longevity.

### Responsiveness

This transition has bridged several obstacles, the first of which has been moderate responsiveness from personnel accountable for getting the job done. This problem is manifested at two hierarchal levels on a Forest--the line officers (Forest Supervisor and District Rangers) who establish program direction, and the project work force who carry out this direction.

Exceptional are those line officers who can place equal priority on providing snags for wildlife and meeting annual timber sell targets, when the latter is a performance appraisal element upon which the agency measures their managerial ability, and the former is not. Until such time as performance appraisals relate equally to all phases of National Forest management (i.e. meeting all targets of the Forest Plan, instead of singling out specific ones such as timber volume), the barrier is still potentially there.

Project workers who perform the details of project layout, whether it be timber sales, timber stand improvement, forest fuels treatment, or other impacting activities, may view snag management requirements as obstacles to full achievement of their functional goals. This is compounded by the volume of similar functional "impediments", such as visual quality, archeologic/historic protection, and others. Often, field-going project personnel are sea-

---

<sup>1</sup>Paper presented at the Snag Habitat Management Symposium, Flagstaff, Ariz., June 7-9, 1983.

<sup>2</sup>Edward W. Styskel is Forest Wildlife Biologist, Deschutes National Forest, Bend, Oreg.



sonal employees with limited personal ownership in determining these specific goals.

Proper emphasis from the line officer to the project work force is essential in stimulating these personnel to achieve all Forest goals, including those dealing with snag management.

#### Snag Status

Another snag management problem is determining and following the status of snags project area by project area. This difficulty is magnified as the area of perspective is enlarged to an entire drainage, Ranger District, or National Forest.

Special snag inventories are time-consuming, and therefore expensive.

Stand examination data, usually collected by foresters for assessing forest stand conditions, offer a reasonable alternative. Owing to regularly low snag densities and small plot size, stand exam plot frequency usually has to be increased to diminish exaggeration of the real-life situation.

It should be recognized that both techniques are a measurement of one point in time and subject to rapid change from natural phenomena and human activities.

Tabulation for monitoring snags and live replacements reserved for wildlife can best be accomplished during the timber marking stage in timber sale preparation. Tally records are recorded in the field which document the number, size, species, and successional condition (Thomas, et al. 1979) of snags or live replacements reserved for wildlife.

Site specific storage and retrieval of this data is necessary in order to be able to track these allocations for future land management decisions. In the Pacific Northwest Region of the U.S. Department of Agriculture--Forest Service, the TOTAL RESOURCE INFORMATION (TRI) System provides an automated system capable of handling this data by management "cell".

#### Minimizing Timber Yield Reduction

Minimizing timber yield falldown due to wildlife tree requirements is still another hurdle. Two concerns have developed--the retardation of growth on crop trees from reserved live replacements, and the genetic character of these reserved live trees.

McDonald (1976) reports in a California study that ponderosa pine seed trees had an inhibitory effect on seedlings beneath them. Live tree replacements could equally be expected, then, to negatively influence predicted timber growth and subsequent yield. Because of this effect, estimated growth loss in managed stands on the Deschutes National Forest is thought to be significant--perhaps as high as

12 percent.<sup>3</sup> Timber volume loss for the recommended densities and sizes of snags to support 60 percent of the maximum potential population of primary<sup>4</sup> excavators account for an additional 6 percent.

Often, live trees recommended by biologists for future snag replacements possess characteristics of genetic inferiority for maximum growth potential. Because anticipated timber growth and yield are usually predicated on growing genetically superior trees, these goals frequently collide.

Reducing these conflicts was the initiative for utilizing the technique of "clumping", whereby  $\frac{1}{2}$  acre parcels were reserved intact within every 8 to 12 acres of cutting unit in lodgepole pine forest (fig. 1).<sup>5</sup> The desired characteristics of these clumps are defined carefully to assure that the proper density and sizing of snags and live replacements are available.

Assumptions are made that the clumps: (1) satisfy distributional requirements based on estimated territory sizes of most primary excavators (Thomas, et al. 1979); (2) reduce the



Figure 1.--"Clumping" of reserved snags and live tree replacements.

<sup>3</sup>Smith, Tony. 1982. The effect of the proposed Deschutes National Forest's snag policy on the growth of managed stands. Unpublished report. Deschutes National Forest, Bend, Oreg.

<sup>4</sup>Deschutes National Forest. 1982. Managed yield tables for the Deschutes National Forest Land Management Plan. Unpublished process records. Deschutes National Forest, Bend, Oreg.

<sup>5</sup>McEwan, Linda. 1983. Personal conversation. Deschutes National Forest, Crescent, Oreg.



inhibitory effect of evenly distributed live tree replacements; (3) diminish the widespread influence of genetically inferior or diseased live replacements on seedling crop trees; (4) lessen blowdown loss experienced by single trees exposed after forest canopy removal; (5) shrink wildlife tree losses associated with other forest activities; and (6) provide habitat values for other wildlife. Monitoring over time will determine the validity of these assumptions.

#### Snag Standing Longevity

Knowledge of the standing "life expectancy" of snags is critically significant in determining how many live tree replacements must be reserved over a managed forest rotation to meet established goals. Few studies have been specifically designed to collect the kind of data a biologist might desire. Interpolation from research conducted with other objectives in mind is often necessary, and the more localized the better.

Factors including soil type, site productivity, climate, heartwood/sapwood ratio, the incidence of insects or disease, and others have been identified by Keen (1955) as influencing the rate of snag fall. To refine the longevity estimates used on the Forest, these factors will be measured in snag longevity monitoring efforts beginning this year.

#### Wildlife Tree Protection

Physical protection of reserved snags and live replacements is the final obstacle. Windthrow, and land management activities such as logging, forest fuel treatment, timber stand improvement, prescribed burning, and public firewood cutting, are all known sources of attrition.

It has been established that snag attrition occurs from windthrow, and is influenced by bole diameter--large diameter snags remaining upright longer than smaller ones (Dahms 1949, Lyon 1977). Determination of this loss is paramount to calculating snag and live replacement needs for areas where snag retention is planned. For example, some areas of the Forest have exhibited reductions in evenly distributed reserved snags of 25 percent for 20-inch or greater dbh snags, and 75 percent for less than 20-inch dbh snags, immediately after canopy removal by clear-cut or shelterwood.

Snag hazards to worker safety and fire protection in woods operations have prompted State Laws and Administrative Rules which require snag felling for reasonable hazard control. The consequences of these requirements can be moderated with careful attention to project design and wildlife tree position. For example, wildlife trees would not be positioned where obvious hazard to log landings or proposed road locations would jeopardize their retention.

While the felling of hazardous snags in timber harvest is a step backwards in terms of

snag management goals, this loss, and that from other causes, can often be mitigated with timber sale generated Knutson-Vandenberg funds to artificially create or manipulate snags. Such plans are underway on the Forest to accelerate snag formation by various techniques, including fire-scarring by piling and burning logging debris at the base of live snag replacements, and topping with explosives (Bull, et al. 1981) or cutting.

The latter technique was successfully contracted this spring on snags and live replacements at a cost of \$45 per tree.<sup>6</sup> Ponderosa pine with dimensions of 18 to 26 inches dbh averaging about 80 feet tall were sawn off at a height of approximately 30 to 50 feet. The live replacements were topped to retain just enough live foliage for the tree to stay alive, the assumption being that a diminished live crown would be more windfirm and less influential on understory retardation and the spread of dwarf mistletoe.

Logging (or thinning) debris disposal and vegetative manipulation accomplished by prescribed burning may consume snags and down logs without pre-planned safe-guards. Loss of snags or live replacements due to post-sale activities has occurred because attention to snags often does not carry through to these stages of timber management. The land manager must learn to think about snags in all types of management activity before this short-circuit can be remedied.

Uncontrolled public firewood cutting can have significant consequences upon the retention of snags for wildlife, especially where relatively flat and open terrain or extensive road systems allow easy vehicular access. Land managers can control this activity, though, to lessen the influence on wildlife trees.

First, a permit system, the provisions of which are legally enforceable and require public user contact with the manager, is requisite. Protection of wildlife trees must be considered in specifying the requirements of the permit. For example, specifications on permissible tree species or diameter, areas open to cutting, or snags with evidence of wildlife use or protective signing may be necessary.

Public education of the potential for conflict between firewood cutting and maintaining snag habitat for wildlife can occur at the time of permit acquisition, and with Public Service Announcements during the woodcutting season.

Violation of permit provisions on the Deschutes National Forest is punishable through criminal citation and fine. In addition, mitigative damages can be assessed against violators for the cost of replacing the felled snag. When

---

<sup>6</sup>Corn, Don. 1983. Personal conversation. Deschutes National Forest, Sisters, Oreg.

available, a suitable live tree of similar dimensions would be killed, with the damage assessment being the cost of artificially inducing mortality, plus the commercial value of the tree. Where live tree replacements are unavailable, the damage assessment would be the cost of constructing, installing, and maintaining suitable nesting and perching structures.

In areas of excessive vulnerability to firewood cutters, "armoring" of wildlife trees is a productive technique. Twisted-wire fence stays nailed on the snag (fig. 2) have effectively protected assailable snags at a cost of about \$3.50 per snag for materials and labor. The narrow stays become virtually invisible from

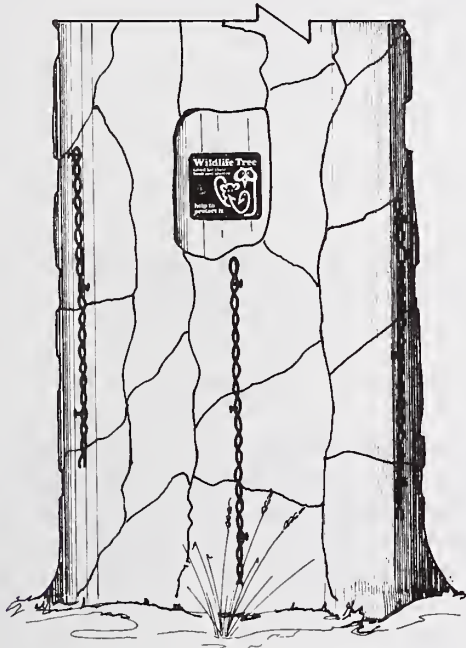

Figure 2.--"Armoring" of tree trunk. Three or four stays, offset to extend height of bole protection, are secured by bent-over nails in sound wood.

a short distance, making this technique suitable even in visually sensitive areas.

#### CONCLUDING REMARKS

While the obstacles to providing suitable snag habitat for dependent wildlife are both diverse and substantial, it is premature to say they are insurmountable. Successful efforts must recognize these problems, receive full commitment to their resolution, be innovative and aggressive in dealing with potential solutions, and closely monitor the results.

#### LITERATURE CITED

- Bull, Evelyn L., Arthur D. Partridge, and Wayne G. Williams. 1981. Creating snags with explosives. USDA For. Serv. Res. Note PNW-393, 4 p. Pac. Northwest For. and Range Exp. Stn., Portland, Oreg.
- Dahms, Walter G. 1949. How long do ponderosa pine snags stand? USDA For. Serv. Pac. Northwest For. and Range Exp. Stn. Res. Note 57, 3 p. Portland, Oreg.
- Keen, F. P. 1955. The rate of natural falling of beetle-killed ponderosa pine snags. J. For. 53(10):720-723.
- Lyon, L. Jack. 1977. Attrition of lodgepole pine snags on the Sleeping Child burn, Montana. USDA For. Serv. Res. Note INT-219, 4 p. Intermt. For. and Range Exp. Stn., Ogden, Utah.
- McDonald, Philip M. 1976. Inhibiting effect of ponderosa pine seed trees on seedling growth. J. For. 74(4):220-224.
- Thomas, Jack W., Ralph G. Anderson, Chris Maser, and Evelyn L. Bull. 1979. 5. Snags. p. 60-77. *In* Wildlife habitats in managed forests: The Blue Mountains of Oregon and Washington. Jack Ward Thomas, tech. ed. USDA For. Serv. Agric. Handb. 553, 512 p.



# Implications of Snag Policies on Management of Southwestern Ponderosa Pine Forests<sup>1</sup>

Peter F. Ffolliott<sup>2</sup>

---

Abstract.--The Southwestern Region of the USDA Forest Service is providing habitat for snag-dependent wildlife species in ponderosa pine (*Pinus ponderosa* Laws.) forests. To evaluate alternative snag retention policies, study areas representing five silvicultural treatments and virgin conditions were evaluated to determine whether or not they met the policies under present conditions, and if not, whether or not policies would be met through natural mortality in the future.

---

## INTRODUCTION

Southwestern ponderosa pine snags are an important habitat component for cavity-nesting wildlife species. At least 49 species of birds, along with the 10 species of mammals and numerous species of insects and herpetofauna, use tree cavities in southwestern forests (Scott and Patton 1975, USDA Forest Service 1977). These cavity-nesters depend on snags and dead portions of live trees for denning, roosting, feeding, and nesting cover. Sixty-three percent of the birds and three-fourths of the mammals that are snag-dependent in southwestern forests are insectivorous (USDA Forest Service 1977). These birds and mammals are often credited with insect control that helps to maintain a healthy ecosystem (Thomas et al. 1975).

Prior to recent years, snags were viewed as potential fire hazards, harborers of disease, and worthless space fillers (McClelland and Frissell 1975). However, in a change of policy, the Southwestern Region of the Forest Service is to provide adequate habitat to maintain self-sustaining populations of snag-dependent wildlife species (USDA Forest Service 1977).

To provide snags to perpetuity to ensure viable populations of snag-dependent wildlife species, it could become necessary to sacrifice timber production. Therefore, a study was undertaken to determine; (a) whether or not snag retention policies could be met solely through natural mortality; and (b) whether or not timber

volumes would be lost and revenues foregone if snags were artificially created.

## STUDY AREAS

Southwestern ponderosa pine forests exist in uneven-aged stands of small, even-aged aggregates ranging from a few trees to stands of several acres (Schubert 1974). Cutting practices imposed in these forests involve a variety of silvicultural treatments undertaken to achieve a variety of multiple use objectives.

Data were obtained from study areas representing different silvicultural treatments, including the Beaver Creek Watersheds, the Heber Watersheds, and the Castle Creek Watersheds (fig. 1). Additionally, data were gathered on study areas representing virgin conditions, including the Castle Creek Watersheds, and the Fort Valley and the Long Valley Experimental Forests.

Snag retention management alternatives were examined on 10 study areas representing five silvicultural treatments; shelterwood-seed tree cut, shelterwood-stripcut, group selection cut, thinning-patch cut, and uniform thinning (table 1). The virgin forests studied provided a reference. Clearcut treatments were not analyzed, since this treatment precludes snag retention.

## METHODS

Snag retention policies of one, two, or three snags per acre were examined under present conditions on the study areas, and under simulated conditions at the end of the 20-year period. Snags were defined as standing dead trees at least 12 inches in diameter and 10 feet in height. No differentiation was made between "hard" snags, those composed of sound wood, and "soft" snags, those characterized by advanced decay and

---

<sup>1</sup>Paper presented at the Snag Habitat Management Symposium, Northern Arizona University, Flagstaff, Arizona, June 7-9, 1983.

<sup>2</sup>Peter F. Ffolliott is Professor, School of Renewable Natural Resources, University of Arizona, Tucson, AZ.

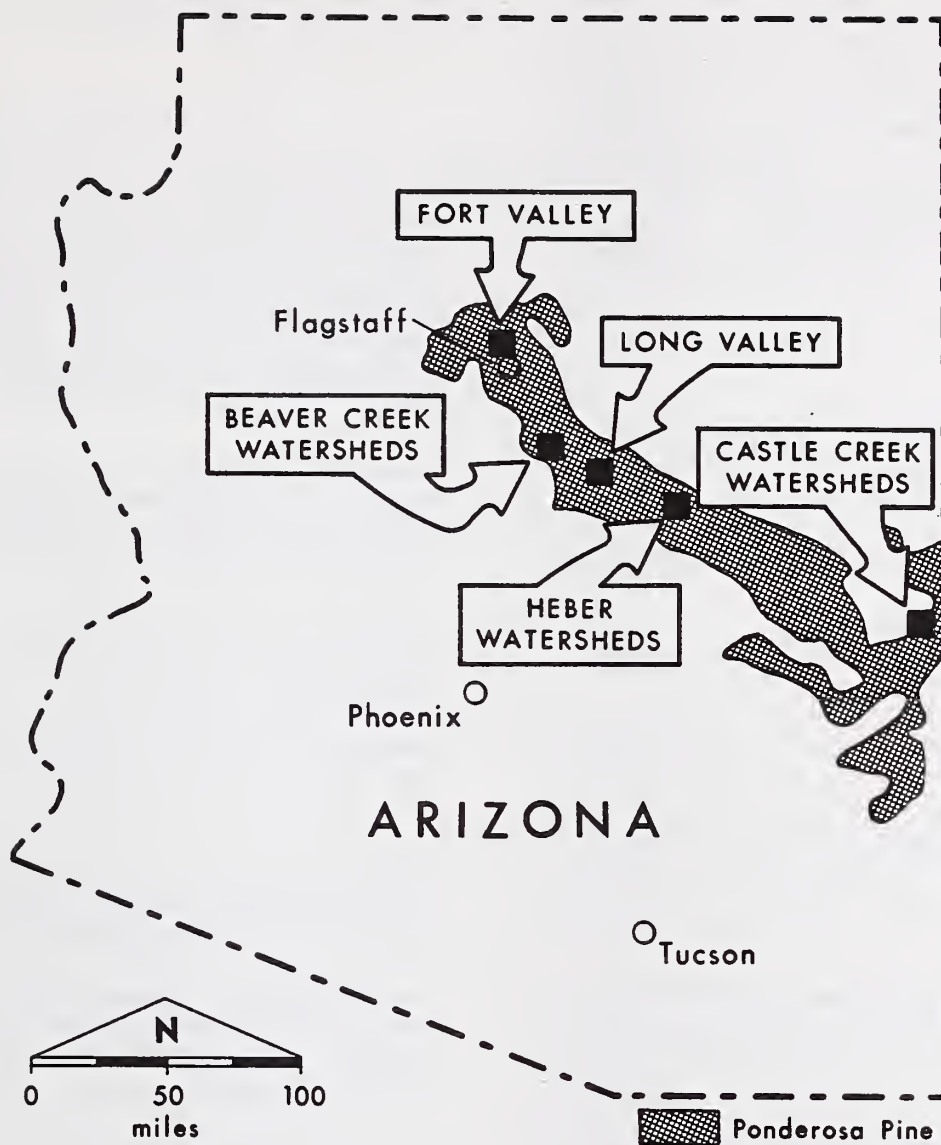

Figure 1. Location of study areas.

deterioration. Twenty years was selected as the simulation period because it coincides with a "typical" cutting cycle in southwestern ponderosa pine forests (Schubert 1974).

To help determine whether or not snag retention policies can be met in the future, a computer simulation model called SNAG was developed. This model estimates natural tree mortality and snag retention in southwestern ponderosa pine forests through time, given inputs of current growing stock and, if available, existing number of snags. In this study, outputs from SNAG were used to determine whether or not the study areas would meet suggested snag retention policies through natural mortality.

Initially, it was determined whether or not snag retention policies could be met solely through natural mortality. To this end, initial forest inventories of the study areas were repeated to summarize current growing stock and existing number of snags. These summaries provided the information to examine the alternative policies under present conditions and to formulate inputs to SNAG to simulate conditions at the end of the 20-year period. If the policies were not

met through natural mortality, and if snags were artificially created, timber volumes lost and revenues foregone were ascertained.

To quantify possible timber volumes lost due to the creation of snags, it was necessary to define a "target" stand toward which forest management should be aimed. A balanced uneven-aged stand was selected as the "target" structure. To define this structure, three parameters were quantified; a "q" ratio<sup>3</sup> of 1.3, a maximum tree diameter of 24 inches, and a residual basal area of 60 square feet per acre. Other quantifications of these parameters could have been made, or another "target" could have been selected. The "target" structure presented herein is simply illustrative.

After defining a "target" stand, any number of scenarios that specify when during the 20-year period snags are to be created, and what size of trees will be sacrificed could be developed to analyze timber volumes lost (Nowakowski 1980).

<sup>3</sup>de Liocount's "q" ratio reflects a decreasing geometric series of numbers of trees per acre for successive diameter classes.



Table 1.--Silvicultural treatments and study areas

Silvicultural treatment and study area	Size (acres)	Description
<u>Shelterwood-seed tree cut</u> Beaver Creek Watershed 8	1,892	Residual densities of 60 sq ft of basal area in size classes 10 in dbh and less, 70 sq ft in 12-22-in dbh classes; stands averaging 24 in in dbh and larger cut in shelterwood-seed tree system.
<u>Shelterwood-stripcut</u> Beaver Creek Watershed 14	1,267	One-third of area cleared in irregular strips averaging 60 ft wide; intervening leave strips thinned to 60 sq ft of basal area.
<u>Group selection cut</u> Beaver Creek Watershed 13	867	Residual density of 99 sq ft of basal area, in uneven-aged structure.
Heber Watersheds	134	Residual density of 98 sq ft of basal area, in uneven-aged structure.
<u>Thinning-patch cut</u> Beaver Creek Watershed 10	571	Irregular openings (1 to 10 acres); timber in leave areas cut in similar manner as Beaver Creek Watershed 8.
West Fork Castle Creek	900	One-sixth area cleared in patches, with remaining five-sixths cut to residual density of 65 sq ft of basal area, in uneven-aged structure.
<u>Uniform thinning</u> Beaver Creek Watershed 17	299	Residual density of 30 sq ft of basal area, in uneven-aged structure.
<u>Virgin forests</u> East Fork Castle Creek	1,163	Density of 134 sq ft of basal area, in uneven-aged structure.
Fort Valley Experimental Forest	76	Density of 175 sq ft of basal area, in uneven-aged structure.
Long Valley Experimental Forest	1,280	Density of 214 sq ft of basal area, in uneven-aged structure.

The one presented below represents a situation in which timber volumes lost are minimized.

Trees in surplus to the "target" stand structure, if present, would be those initially used to create snags. Of course, merchantable volumes lost by creating snags from surplus trees would have to be reflected by losses in timber volumes and revenues foregone at the time of harvesting. It was assumed that any timber harvesting operation would occur at the present time.

If additional trees were required to meet a policy, a sacrifice in growing stock prescribed by the "target" stand would be necessary. Unfortunately, this latter action would delay meeting

the conditions specified by the "target," resulting in additional, but unknown, costs. In this scenario, it was assumed that, if growing stock had to be sacrificed, snags would be created at the present time, starting with trees 12 inches in diameter. By starting with the smallest trees, less timber volumes would be lost to subsequent harvesting.

Calculations of revenues foregone were based on stumpage value of \$75 per thousand board feet of lumber. Future values of stumpage at the end of the 20-year period were calculated by the general compound interest formula at 5 and 10 percent. Revenues foregone represent approximated losses only, as these values will undoubtedly vary

with distribution of harvest volumes by size and grade.

## RESULTS AND DISCUSSION

Analysis of snag retention policies met solely through natural mortality indicated that, under present conditions, none of the study areas subjected to silvicultural treatments met any of the suggested policies. In fact, only one of the virgin forests examined, the Long Valley Experimental Forest, met snag retention policies under present conditions, and this area met all of the policy standards.

Under simulated conditions at the end of the 20-year period, the areas subjected to the shelterwood-seed tree cut, the shelterwood-stripcut, and the group selection cut would only meet a snag retention policy of one snag per acre through natural mortality. Areas representing the other silvicultural treatments would meet none of the policies. All of the virgin forests would meet snag retention policies of one or two snags per acre and, of course, the Long Valley Experimental Forest would support three snags per acre.

From this analysis, virgin forests would meet a snag retention policy of one or two snags per acre through natural mortality at the end of the 20-year period. If three snags per acre were required, additional snags must be artificially created. Losses in timber volumes in virgin forests being managed for three snags per acre (and if these forests are to be harvested) would approximate 60 board feet per acre, mostly in trees 12 inches in diameter. Present value of this loss is \$4.50 per acre. Future values of this loss at the end of the 20-year period would be nearly \$12 per acre at 5 percent and approximately \$30.50 per acre at 10 percent interest rates.

The study areas subjected to the shelterwood-seed tree cut, the shelterwood-stripcut, and the group selection cut would generally meet a policy of one snag per acre through natural mortality over the 20-year period. However, if managed for two snags per acre, losses of approximately 115 board feet per acre would occur, primarily in trees 12 to 14 inches in diameter. Present value of this loss is almost \$8.75 per acre, and future values are about \$23 per acre at 5 percent and nearly \$58 per acre at 10 percent interest rates. If managed for three snags per acre, losses over the 20-year period would be 220 board feet per acre. Present value of this loss is \$16.50 per acre, while future values would be nearly \$44 per acre at 5 percent and \$111 per acre at 10 percent interest rates.

Study areas representing the thinning-patch cut and the uniform thinning silvicultural treatments would not meet any of the snag retention policies through natural mortality at the end of the 20-year period. Therefore, if managed for one snag per acre, losses would approximate 90 board feet per acre, presently valued at about \$7 per

acre. Future values of this loss would be \$18 at 5 percent and almost \$45.50 per acre at 10 percent interest rates. If managed for two snags per acre, losses would be 165 board feet per acre. Present value of this loss is approximately \$12.50 per acre, and future values would be in excess of \$32.50 at 5 percent and nearly \$83.50 at 10 percent interest rates. Finally, if managed for three snags per acre, losses would approach 280 board feet per acre, presently valued at \$21 per acre. Future values of this loss would be about \$56 at 5 percent and \$141 at 10 percent interest rates.

It must be emphasized that the study areas evaluated are illustrative only, since implementation of a given silvicultural treatment usually varies in its prescription. Therefore, the magnitudes of timber volumes lost and revenues foregone discussed are only general guidelines.

## SUMMARY

Depending upon the snag retention policy followed, some southwestern ponderosa pine forests will meet the policy requirements at the end of a 20-year period through natural mortality. Other forests subjected to particular silvicultural treatments will require artificial creation of snags. As a result, timber production may be sacrificed.

To determine timber volumes lost and revenues foregone through artificial creation of snags, a "target" stand toward which forest management should be aimed must be defined. Also, the point in time when snags are to be created must be determined. Given this information, and assuming a specific interest rate, it is possible to estimate timber volumes lost and revenues foregone.

While the results of this study pertain to southwestern ponderosa pine forests, a similar approach could be helpful in evaluating snag policies with respect to timber volumes lost and revenues foregone in other forest types.

## LITERATURE CITED

- McClelland, B. R., and S. S. Frissell. 1975. Identifying forest snags useful for hole-nesting birds. *Journal of Forestry* 73:414-417.
- Nowakowski, N. A. 1980. Assessment of snag policies and their effects on timber harvests. Master's Thesis, University of Arizona, Tucson, 85 p.
- Schubert, G. H. 1974. Silviculture of southwestern ponderosa pine: The status of our knowledge. USDA Forest Service, Research Paper RM-123, 71 p.
- Scott, V. E., and D. R. Patton. 1975. Cavity-nesting birds of Arizona and New Mexico forests. USDA Forest Service, General Technical Report RM-10, 52 p.



Thomas, J. W., G. L. Crouch, R. S. Bumstead, and L. D. Bryant. 1975. Silvicultural options and habitat values in coniferous forests. In Proceedings of Symposium on Management of Forest and Range Habitats for Nongame Birds. USDA Forest Service, General Technical Report WO-1, pp. 272-287.

USDA Forest Service. 1977. Forest Service Manual, Title 5151.13c (Policy), Fire Management, np.

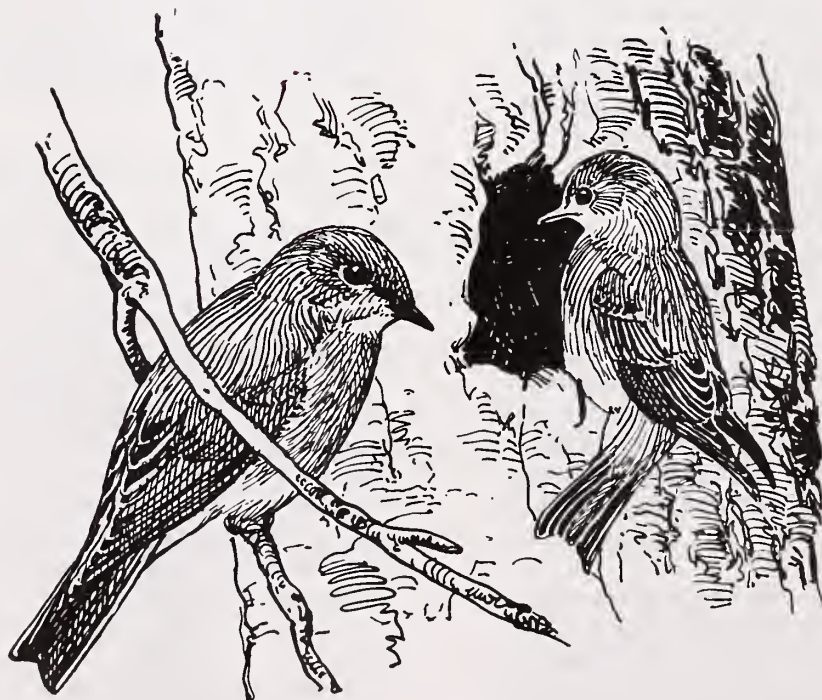

# Coarse Woody Debris and Debris-Dependent Wildlife in Logged and Natural Riparian Zone Forests — A Western Oregon Example<sup>1</sup>

Steven P. Cline and Charles A. Phillips<sup>2</sup>

---

Abstract.--We conducted a reconnaissance study to determine some structural aspects of riparian zone forests and the effects of logging upon woody debris wildlife habitat. We also conducted a literature search to gather information upon the debris-dependent wildlife in riparian zone forests, and how they are influenced by timber management. This information was synthesized in a hypothetical example of snag management in the Coast Range of Oregon. We found that snag habitat of the larger woodpeckers was reduced by clearcutting and we predicted that shortened rotations in the future will reduce or even locally extirpate 20 bird and 5 mammal species. We calculated that the snag requirements of hole-nesting birds are not met using only snags in riparian zone buffer strips. An active program of dead tree management on upland areas is also necessary.

---

## INTRODUCTION

Swanson et al. (1982) define the riparian zone functionally as the zone of direct physical, chemical and biological interaction between terrestrial and stream ecosystems. Riparian zone forests control the stream environment through shading, deposition of fine and coarse plant matter, stabilizing stream banks, and filtering dissolved nutrients and sediment (Meehan et al. 1977). Coarse woody debris from riparian zone forests shape channel morphology and controls routing of water and sediment storage. Riparian zone vegetation provides diverse wildlife habitat because of a land/water interface, multiple horizontal and vertical edges and multiple combinations of successional stages (Thomas et al. 1979).

Timber management is the major land use of forested mountains in western Oregon. Clearcut logging of riparian zone forests drastically changes the stream environment by initially reducing shade and organic matter inputs, adding unstable logging slash and destabilizing banks through yarding and root decay (Brown and Krygier

1970, Lammel 1972, Bryant 1980). Logging and road building can trigger landslides that enter channels, form debris torrents, and scour or "sluice out" the accumulated sediment and woody debris (Swanson and Lienkaemper 1978, Gresswell et al. 1979). The influence of logging upon the stream environment has long concerned fisheries and wildlife biologists, hydrologists and foresters (Narver 1971). Consequently, riparian zone buffer strips are now used to protect the stream environment and maintain the multiple functions of riparian zone forests (Steinblums 1978).

Riparian zone forests perform multiple functions. In this paper we focus upon one of these: habitat for wildlife dependent upon standing and fallen dead trees. Dead tree management on upland slopes conflicts directly with timber management (Meslow 1978, Cline et al. 1980). Management for dead trees in riparian zone forests may avoid some of the direct conflicts with intensive forestry and coordinated effectively with the established program of buffer strip management. We established two study objectives: (1) describe riparian zone forests, their woody debris characteristics, and their debris-dependent wildlife under both natural conditions and management, and (2) evaluate the importance of buffer strips to dead tree habitat management.

---

<sup>1</sup>Paper presented at the Snag Habitat Management Symposium, Flagstaff, Arizona, 7-9 June, 1983.

<sup>2</sup>Steven P. Cline is a Research Assistant, Department of Forest Science, Oregon State University, Corvallis, Ore., and Charles A. Phillips is a Wildlife Biologist, United States Forest Service, Siuslaw National Forest, Corvallis, Ore.

## STUDY AREA

We studied the riparian forests along the South Fork of Rock Creek, a fourth-order stream draining 13.5 km<sup>2</sup> of the Siuslaw National Forest, central Coast Range of Oregon. About 70% of the upland is covered by mature and old-growth



Douglas-fir (*Pseudotsuga menziesii*) forests with Douglas-fir plantations covering the remaining 30%. In this watershed the drainage density is 3800 m/100 ha and the riparian zone forest averages 40 m wide; therefore, about 15% of the Rock Creek watershed supports riparian zone vegetation.

#### METHODS

In this study we attempted to interface research and management, a relationship we believe requires cultivation. During this process we exposed large gaps in our empirical knowledge. We lacked wildlife abundance data in relation to woody debris characteristics, especially for woody debris in managed forests. Consequently, we were forced to use general relationships between woody debris characteristics and species use to predict the effects of timber management upon debris-dependent wildlife. We could not predict accurate changes in population levels using this method, only trends. Furthermore, a limitation with any prediction is that we, nor anyone, can predict the exact course of forestry practices.

#### Reconnaissance Study

Tree fall is one functional link between forests and streams. During reconnaissance of the Rock Creek watershed we observed that the source of most in-stream debris was within 30 m of the channel edge. Consequently we defined riparian forests as those forests growing within a 60-80 m zone centered on stream channels. The zone includes vegetation growing in the channel, on the floodplain, and on the bottom of upland slopes, i.e., toeslopes.

We laid out a large plot 50 m long by 60 m wide centered on the channel and divided it into 10 m<sup>2</sup> subplots. We then made a complete inventory of trees, snags and logs and recorded: subplot number, geomorphic unit (channel, floodplain, and toeslope), species, decay stage, crown class and length, dbh or end diameter, length or height, and wildlife use. In this study a snag was any standing dead tree  $\geq 15$  cm dbh and  $\geq 1.5$  m tall, and a log was any down tree or piece thereof,  $\geq 15$  cm diameter at the small end and  $\geq 1$  m long.

To determine the effect of logging upon snags and logs within riparian zone forests we selected sites increasingly disturbed by timber management activities: (1) untreated old-growth riparian zone forests (control, n = 2), (2) salvage logged and the stream channel sluiced (n = 1), (3) clear-cut logged leaving a narrow discontinuous buffer strip and channel sluiced (n = 1), and (4) clear-cut logged without a buffer strip (n = 1). Woody debris was compared between treated and control forest.

#### Literature Synthesis

Data from our reconnaissance study was supplemented with pertinent literature, unpublished data and manuscripts, and working documents of the

Siuslaw National Forest. This information was synthesized as a hypothetical example of a 100-ha snag management area within the South Fork of Rock Creek watershed.

#### RESULTS

##### Natural Forests

During development riparian forests changed from predominately deciduous to coniferous trees (fig. 1). In successional stages 1 and 2 red alder (*Alnus rubra*) formed dense, nearly pure stands along streamside zones, especially if the stream channel had been disturbed by debris torrents<sup>3</sup>. During stages 3 and 4 red alder declined because of suppression by riparian and upland forests. In stages 5 and 6 the overstory was mixed with Douglas-fir, western red cedar (*Thuja plicata*), and western hemlock (*Tsuga heterophylla*) and the understorey with western yew (*Taxus brevifolia*) and bigleaf maple (*Acer macrophyllum*).

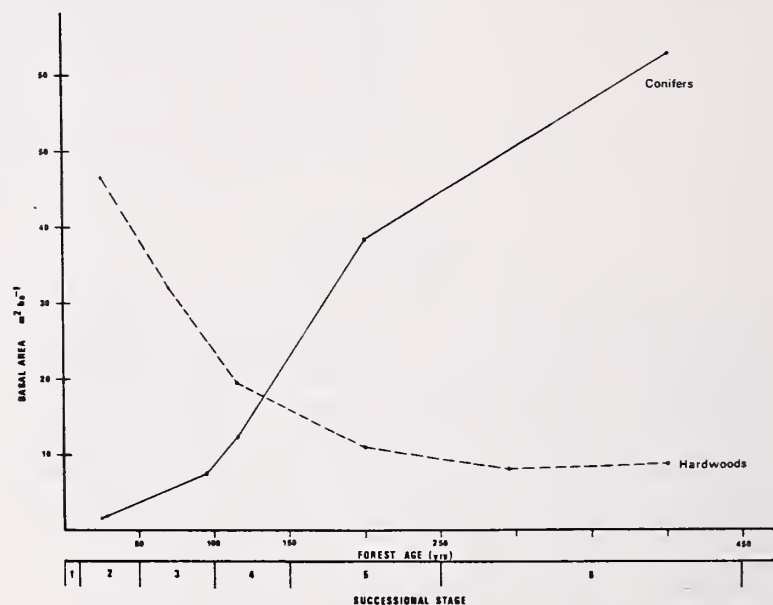

Figure 1.--Tree basal area in successional stages of riparian zone forests, western Oregon.

The structure of riparian zone forests was substantially influenced by stream width because light penetration to the riparian zone increased with stream width, and larger streams had greater ability to disrupt forest succession (fig. 2). Consequently riparian vegetation growing on or below the floodplain of some third order and larger streams developed independently from forest vegetation above the floodplain. For example, red alder and willow (*Salix* spp.), both early successional species, were maintained with older riparian and upland forests along larger streams (fig. 2C). In the South Fork of Rock Creek, however, third and fourth order channels composed only 12% of the total stream length; therefore, red alder and willow were ephemeral in most of this watershed.

<sup>3</sup>Cline, S. P. and F. J. Swanson. Development of riparian and hillslope vegetation after clear-cutting, western Oregon (in preparation).

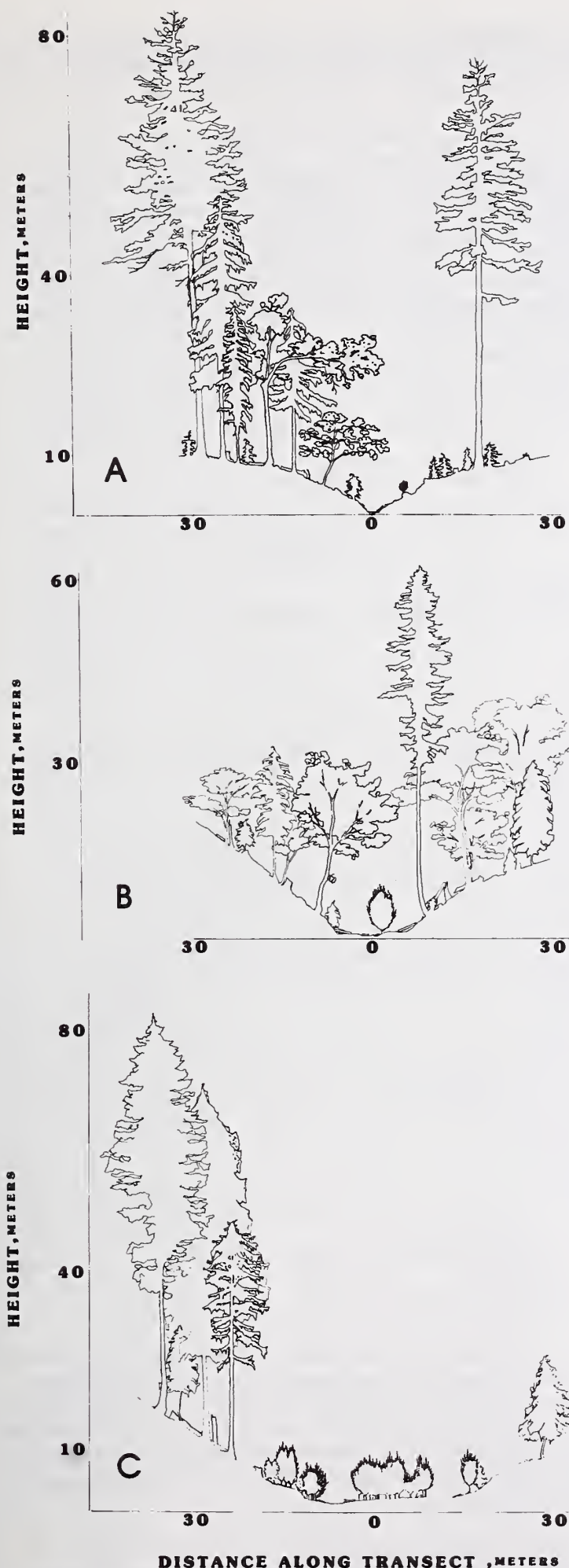

Figure 2.--Examples of cross-sections through old-growth riparian zone forests along (A) first, (B) third, and (C) fourth order streams, Oregon Coast Range. The number of trees represent an average for a 10 m wide cross-section ( $n = 5$ ).

Basal area of snags increased with forest age, and snags changed from predominately deciduous to coniferous (fig. 3). Relative to total basal area (tree plus snag), snag basal area increased from 3 to 11% in successional stage 1 and 6, respectively. Snag density averaged 240, 37, 5, 4, and 12  $\text{ha}^{-1}$ , and snag dbh averaged < 15, 27, 38, 64 and 102 cm in successional stages 2-6, respectively. In the Oregon Coast Range snag densities were lower in riparian zone forests than upland forest of the same successional stage (Cline, 1977). Diameters of logs along streams averaged 32, 42, 59, and 62 cm in successional stages 3-6, respectively; the corresponding log volumes were 233, 370, 720, and 1057  $\text{m}^3\text{ha}^{-1}$  (Cline 1977). In seral stages 1-3 there were two sources of log habitat: snag break-up and residual logs carried over into the new forest after wildfire or logging (Swanson and Lienkaemper 1978, Cline et al. 1980). In stages 4-6 a third source of logs was tree uprooting (Graham 1982). The large logs produced in stages 4-6 are important to stream ecosystems because larger logs form longer lasting debris dams in streams, longer logs are required to form debris dams as stream width increases, and large logs form residual in-stream debris dams after logging or wildfire (Swanson et al. 1976, Swanson and Lienkaemper 1978, Bilby and Likens 1980).

On the Siuslaw National Forest approximately 80 species of snag and log-dependent wildlife use riparian zone forests - 43 birds, 24 mammals and 13 reptiles and amphibians<sup>4</sup>. The total number of species increased dramatically from successional stages 1 to 6, especially bird species numbers which increased nearly 400% (fig 4). Meanwhile the number of mammal and reptile and amphibian species increased 50 and 0%, respectively. The number of wildlife species using snags only, logs only and both snags and logs was 48, 24, and 8, respectively. Birds were snag-dependent and reptiles and amphibians were log-dependent, but among mammals some species

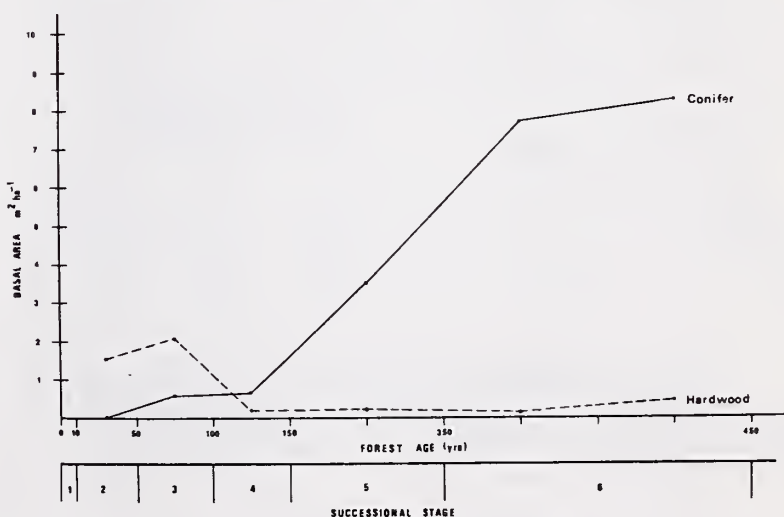

Figure 3.--Snag basal area in successional stages of riparian zone forests, western Oregon.

<sup>4</sup>Phillips, C. A., and others. 1980. Wildlife habitats and species management relationships program, Vols. I-IV. USDA Forest Service. Pacific Northwest Region. On file at Siuslaw National Forest, Corvallis, Ore.



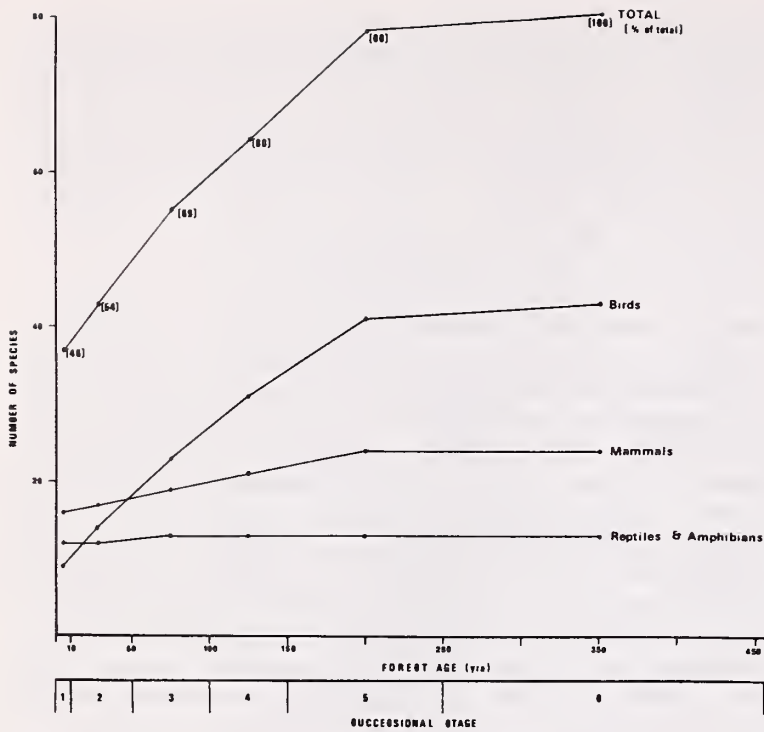

Figure 4.--Number of species of debris-dependent wildlife in successional stages of riparian forests, western Oregon.

used snags only, logs only or both. All wood decay stages were used by debris-dependent wildlife in riparian zone forests, but the percentage of species using decay stage 1 (no decay) and stage 5 (advanced decay) was lower than use of stages 2-4 (moderate decay) (table 1). This pattern of preferential use was evident for mammals and birds. Stage of decay influences not only the type of wildlife use, but also the degree of use (Mannan et al. 1980).

Table 1.--Frequency distribution of snag- and log-dependent species by wood decay stage, western Oregon. Feeding and breeding use only<sup>1</sup>.

Vertebrate group	Distribution by decay stage, %				
	1	2	3	4	5
Birds	53	79	100	53	18
Mammals	17	100	100	100	38
Reptiles & amphibians	62	100	100	100	77
All	43	89	100	76	35

<sup>1</sup>Fish and wildlife habitats in western Oregon and Washington, E. Reade Brown (ed.), USDA For. Serv. Pacific Northwest Region, unpublished appendix.

#### Managed Forests

The estimated rotation age is 65-85 years for intensively managed commercial timber land on the Siuslaw National Forest; this rotation age is proposed for 77% of the land area. Extended rotation ages of about 300 years are planned for the remaining 23% of the land base; this includes the Rock Creek watershed. If the above situation develops on the Siuslaw National Forest, 20 bird

and 5 mammal species will be severely reduced or even locally extirpated because successional stages 4-6 will be mostly eliminated (fig. 4).

Salvage treatment reduced snag densities slightly when compared to control forests, but densities of snags in clearcut/narrow buffer and clearcut/no buffer treatments were greater than or equal to those in control forests (table 2). Log densities in sluiced channels were reduced 70-90% from control levels, but in the clearcut/no buffer treatment densities of logs were similar to control levels (table 2). Log densities on toeslopes were reduced by salvage but log densities in clearcuts exceeded control levels (table 2).

Table 2.--Densities of snags and down logs after logging treatments, old-growth riparian zone forests, western Oregon.

Logging treatment	Down logs (ha <sup>-1</sup> ) X(SE/N)			Snags (ha <sup>-1</sup> ) X(SE/N)
	Channel/floodplain	Toeslope	Total	
None (old growth)	584(117/7) <sup>1</sup>	291(89/2)	326	12(3/5) <sup>2</sup>
Toeslope salvaged/channel sluiced	189(-/1)	177(-/1)	180	7(-/1)
Toeslope clearcut with narrow buffer strip/channel sluiced	55(-/1)	444(-/1)	373	29(-/1)
Toeslope clearcut with no buffer strip	602(168/5) <sup>1</sup>	878(-/1)	859	14(-/1)

<sup>1</sup>This study plus Lammel (1972).

<sup>2</sup>This study plus Cline (1977).

Size reduction of woody debris habitat was an obvious alteration induced by logging. Compared to control forests average snag dbh and height decreased 48-76% and 62-90%, respectively, depending upon treatment; the same treatments reduced mean log diameter and length 9-38% and 24-59%, respectively (table 3).

The frequency distribution of snag decay stages was significantly different in old-growth riparian zone forests than in upland clearcuts (table 4). We made this comparison because we did not measure enough snags (n = 11) in clearcut riparian forests to compare statistically with snags in control forests. The decay stage distribution of logs was significantly different in

Table 3.--Dimensions of snags and down logs after logging treatments, old-growth riparian zone forests, western Oregon. Logs were decay stage 3 only.

Logging treatment	Snags		Logs	
	Diameter (cm) $\bar{X}(SE/N)$	Height (m) $\bar{X}(SE/N)$	Diameter (cm) $\bar{X}(SE/N)$	Length (m) $\bar{X}(SE/N)$
None (old growth)	90 (3/144) <sup>1</sup>	19.9 (1.3/144) <sup>1</sup>	55 (4/67)	7.4 (1.3/67)
Toeslope salvaged/channel sluiced	22 (8/2)	7.3 (2.3/2)	50 (5/27)	5.6 (1.1/27)
Toeslope clearcut with narrow buffer strip/channel sluiced	39 (8/7)	7.5 (1.2/7)	44 (4/51)	4.1 (0.6/51)
Toeslope clearcut with no buffer strip	47 (5/4)	1.9 (0.3/4)	34 (1/108)	3.0 (0.3/108)

<sup>1</sup>This study plus Cline (1977).

Table 4. Frequency distribution of wood decay stages after logging treatments, old-growth riparian zone and upland forests, western Oregon.

Logging treatment	Distribution by decay class, %				
	1	2	3	4	5
(a) Snags					
None (riparian old-growth) <sup>a1,2</sup>	2	19	36	11	32
Upland clearcut <sup>b1</sup>	18	39	23	4	16
(b) Logs					
None (old-growth) <sup>a3</sup>	0	2	68	26	4
Toeslope clearcut with narrow buffer strip and sluiced channel <sup>b</sup>	3	26	64	7	0
Toeslope clearcut with no buffer strip <sup>b</sup>	0	40	52	7	1

<sup>1</sup>Cline (1977).

<sup>2</sup>For snags and logs, treatments with different letters are significantly different, chi-square test,  $P < 0.005$ .

<sup>3</sup>Includes toeslope salvaged/channel sluiced.

control forests than in both the clearcut/narrow buffer and clearcut/no buffer treatments (table 4). Salvage logging did not change the decay stage distribution of logs relative to control forests and was averaged with the control forests. Snags and logs were effected similarly by clearcutting: the frequency of decay stages 1 and 2 increased while the frequency of 4 and 5 decreased.

If the alterations of woody debris as described above are or will be widespread, then breeding habitat of the pileated and Lewis' woodpecker, and possibly the hairy woodpecker and common flicker will be reduced because the residual snags in clearcuts are near or below the minimum size used<sup>5</sup> (Mannan et al. 1980). Harris et al. (1982) estimated a 10 and 29% decline in species in short rotation forests without snags and without snags and down logs, respectively. In contrast, we currently do not know the relationship between down log size and use by log-dependent mammals, reptiles, and amphibians.

#### Riparian Zone Buffer Strips

Wildlife biologists on the Siuslaw National Forest suggest areas adjacent to or within 100 m of water, i.e., riparian zones, as one of four locations for dead tree wildlife habitat<sup>6</sup>. The importance of riparian zones in providing dead tree habitat is explicit in these guidelines because riparian zones support diverse wildlife (Thomas et al. 1979) and minimize the direct conflicts with logging systems, herbicide application, slash burning and safety requirements. Toews and Moore (1982) recommend maintaining mature and old-growth forest buffer strips as a future source of large debris for streams. Are riparian zone buffer strips the panacea for dead tree management?

To examine this question we developed a hypothetical 100-ha snag management area within the South Fork of Rock Creek watershed. We subdivided the area using current information on the distribution of forest successional stages: 2.3, 8.2, 27.3, 50.4, 10.3 and 1.5 ha for successional stages 1-6, respectively<sup>7</sup>. The density and size distribution of snags was based on Cline (1977). Snag requirements of primary hole-nesting birds was calculated according to Thomas et al. (1979), except that we used a ratio of 31:1 for snags without to snags with cavities<sup>5</sup>.

<sup>5</sup>Manuwal, D. A. and J. Zarnowitz. 1981. Cavity nesting birds of the Olympic National Forest, Washington. College of Forest Resources, Univ. of Washington, Seattle. Unpublished manuscript. 143 p.

<sup>6</sup>Janik, P. and G. Silovsky [n.d.] Wildlife plan for dead and defective tree habitat. USDA Forest Service. Pacific Northwest Region. On file at the Siuslaw National Forest, Corvallis, Ore. 28 p.

<sup>7</sup>Stream Assessment Surveys. 1979-81. USDA Forest Service. Pacific Northwest Region. Siuslaw National Forest. Alsea Ranger District.



We estimated that the hard snag requirements of the six primary hole-nesting birds at the 100% population level would be met with 18% of all snags on the 100-ha management unit (Table 5). Riparian zone forests supplied a maximum of 35% of the total hard snag requirement, but 80% of these are < 30 cm dbh. If the riparian zone buffer strip was mature and old-growth only, a larger proportion of hard snags > 60 cm were supplied, but the total contribution to snag numbers decreased to 10%.

Table 5.--Snag resource and hard snag requirements of primary hole-nesting birds in riparian and hillslope forests on a hypothetical 100-ha snag management area, Oregon Coast Range.

Forest	Area ha	Number of snags			Total
		< 30 cm	30-60 cm	> 60 cm	
Riparian <sup>1</sup>	15	404	62	27	493
Hillslope <sup>1</sup>	85	5283	1086	845	7214
Total	100	5687	1148	872	7707
Hard snags required by wood- peckers, 100% population level <sup>2</sup>		590	394	498	1408
% of snag requirement fulfilled by ripar- ian		68	16	5	
% of snag requirement fulfilled by ripar- ian, mature and old growth forests only		< 1	13	17	

<sup>1</sup>See text for percent areas of each successional stage.

<sup>2</sup>Common flicker (*Colaptes aratus*), Pileated woodpecker (*Dryocopus pileatus*), Lewis' woodpecker (*Asyndesmus lewis*), yellow-bellied sapsucker (*Sphyrapicus varius*), hairy woodpecker (*Dendrocopos villosus*), and downy woodpecker (*Dendrocopos albolarvatus*).

Even if riparian zone buffer strips supplied all of the snags required for a 100-ha snag management area, they probably would be too small to meet the territorial needs of woodpeckers, most of which range > 10 ha<sup>8</sup>. In addition, most buffer

<sup>8</sup>Bruce Marcot. 1983. Personal conversation. Research Assistant, Department of Fisheries and Wildlife, Oregon State University, Corvallis, Ore.

strips, as currently designed, would not serve as a long-term source of woody debris habitat because they are too susceptible to uprooting by wind (Steinblums 1978). Among 27 buffer strips established 1-15 years ago in the western Oregon Cascades, the mean rate of uprooting was 33.3, 2.8, and 0.3 stem ha<sup>-1</sup> year<sup>-1</sup> for unstable, moderately stable and stable buffer strips, respectively. Assuming that these blowdown rates remained constant, we estimated their mean longevity to be 7, 36 and 151 years, respectively. Since uprooting rates probably slow down, these represented worst case estimates. We estimated that 67% of these buffer strips will stand less than 60 years. Stable buffer strips were protected from prevailing winds by high, nearby ridges and by surrounding, intact forest (Steinblums 1978).

We concluded that riparian zone buffer strips can only supplement the overall hard snag requirement of woodpeckers; upland forests will contain nearly two-thirds of all snags required at the 100% population level. However, buffer strips might be the best place to leave the largest snags and logs. Here they avoid direct conflict with logging while forming long-lasting habitat for both terrestrial and aquatic organisms.

#### SUMMARY

After logging old-growth riparian zone forests the average size of snags and logs decreased and the frequency of sound and slightly decayed wood increased relative to wood with advanced decay. Debris-dependent birds were estimated to be the most vulnerable to timber management because: (1) most birds were snag-dependent and after logging snags were too small for maximum species utilization, and (2) rotation lengths, especially future ones, will eliminate successional stage 4-6, where the number of bird species was highest. The woody debris resource of riparian zone forests can be used to supplement, but cannot replace, an active program of dead tree management in upland forests. Buffer strips as currently designed cannot be considered a long-term source of old-growth forest habitat or dead tree wildlife habitat, but the research of Steinblum (1978) suggests many ways to increase buffer strip stability. In addition, riparian zone buffer strips continue to perform other functions such as shading, litter deposition, and sediment and debris trapping as they stabilize.

#### ACKNOWLEDGEMENTS

We thank Paula Reid for field assistance and art work; Barbara J. Rosenbaum for graphics; Allan Doerksen for photographic work; Frederick J. Swanson and Karen Luchessa, Research Work Unit 1653 and 1251, respectively, USDA Forest Service, Pacific Northwest Forest and Range Experiment Station for manuscript review, logistical support and field assistance; and Lu Berger and Julie Cone for manuscript typing. This research was funded by a National Science Foundation grant (DEB 811 2455).

## LITERATURE CITED

- Bilby, R. E. and G. E. Likens. 1980. Importance of organic debris dams in the structure and function of stream ecosystems. *Ecology* 61: 1107-1113.
- Brown, G. W. and J. T. Krygier. 1970. Effects of clear-cutting on stream temperature. *Water Resour. Res.* 6(4):1133-1139, illus.
- Bryant, M. D. 1980. Evolution of large, organic debris after timber harvest: Maybeso Creek, 1949 to 1978. USDA For. Serv. Gen. Tech. Rep. PNW-101. 30 p. Pac. Northwest For. and Range Exp. Stn., Portland, Ore.
- Cline, S. P. 1977. The characteristics and dynamics of snags in Douglas-fir forests of the Oregon Coast Range. M.S. Thesis. Oregon State Univ., Corvallis. 106 p.
- Cline, S. P., A. B. Berg, and H. M. Wight. 1980. Snag characteristics and dynamics in Douglas-fir forests, western Oregon. *J. Wildl. Manage.* 44:773-786.
- Graham, R. L. L. 1982. Biomass dynamics of dead Douglas-fir and western hemlock boles in mid-elevation forests of the Cascade Range. Ph.D. Thesis. Oregon State Univ., Corvallis. 152 p.
- Gresswell, S., D. Heller, and D. N. Swanston. 1979. Mass movement response to forest management in the central Oregon Coast Ranges. USDA For. Serv. Res. Bull. PNW-84. 26 p., illus. Pac. Northwest For. and Range Exp. Stn., Portland, Ore.
- Harris, L. D., C. Maser, and A. McKee. 1982. Patterns of old growth harvest and implications for Cascades wildlife. p. 374-392. *In* Trans. 47th No. Amer. Wildl. and Nat. Resources Council. Portland, Ore.
- Lammel, R. F. 1972. Natural debris and logging residue within the stream environment. M.S. Thesis. Oregon State Univ., Corvallis. 49 p.
- Mannan, R. W., E. C. Meslow, and H. M. Wight. 1980. Use of snags by birds in Douglas-fir forests, western Oregon. *J. Wildl. Manage.* 44:787-797.
- Meehan, W. R., F. S. Swanson, and J. R. Sedell. 1977. Influences of riparian vegetation on aquatic ecosystems with particular reference to salmonid fishes and their food supply. p. 137-145. *In* Importance, preservation, and management of riparian habitat: a symposium. R. R. Johnson and D. A. Jones, eds. Gen. Tech. Rep. RM-43. USDA For. Serv., Rocky Mtn. For. and Range Exp. Stn., Ft. Collins, Colo.
- Meslow, E. C. 1978. The relationship of birds to habitat structure - plant communities and successional stages. p. 12-18. *In* Proc. of workshop on nongame bird habitat management in coniferous forests of the western United States. USDA For. Serv. Gen. Tech. Rep. PNW-64. Pacific NW For. and Range Exp. Stn., Portland, Ore.
- Narver, D. W. 1971. Effects of logging debris on fish production. p. 100-111. *In* Forest land uses and stream environment, a symposium. J. T. Krygier and J. D. Hall, eds. Oregon State Univ., Corvallis.
- Steinblums, I. J. 1978. Streamside buffer strips: survival, effectiveness, and design. M.S. Thesis. Oregon State Univ., Corvallis. 181 p.
- Swanson, F. J., S. V. Gregory, J. R. Sedell, and A. G. Campbell. 1982. Land-water interactions: the riparian zone. p. 267-291. *In* Analysis of coniferous forest ecosystems in western United States. R. L. Edmonds, ed. US/IBP Synthesis Series 14. Hutchinson Ross Publishing Co., Stroudsburg, Penn.
- Swanson, F. J. and G. W. Lienkaemper. 1978. Physical consequences of large organic debris in Pacific Northwest streams. USDA For. Serv. Gen. Tech. Rep. PNW-69. 12 p. Pacific Northwest For. and Range Exp. Stn., Portland, Ore.
- Swanson, F. J., G. W. Lienkaemper, and J. R. Sedell. 1976. History, physical effects and management implications of large organic debris in western Oregon streams. USDA For. Serv. Gen. Tech. Rep. PNW-56. 15 p. Pacific Northwest For. and Range Exp. Stn., Portland, Ore.
- Thomas, J. W., R. G. Anderson, C. Maser, and E. L. Bull. 1979. Snags. p. 60-77. *In* Wildlife habitats in managed forests in the Blue Mountains of Oregon and Washington. USDA For. Serv. Agric. Handb. 553. Washington, D.C.
- Thomas, J. W., C. Maser, and J. Rodick. 1979. Riparian zones. p. 40-47. *In* Wildlife habitats in managed forests in the Blue Mountains of Oregon and Washington. USDA For. Serv. Agric. Handb. 553. Washington, D.C.
- Toews, D. A. A. and M. K. Moore. 1982. The effects of streamside logging on large organic debris in Carnation Creek. Province of British Columbia, Ministry of Forests, Vancouver, B.C. Publ. No. R 28-81071. 29 p.



# The Long-Term Effect of Timber Stand Improvement on Snag and Cavity Densities in the Central Appalachians<sup>1</sup>

John J. Moriarty and William C. McComb<sup>2</sup>

---

Abstract.--Snag and cavity densities were measured on two watersheds in a mixed mesophytic forest in eastern Kentucky. One watershed received timber stand improvement (TSI) by girdling 20-30 years prior to measurement and one did not receive TSI. There were more snags on the TSI watershed than on the non-TSI watershed. Total cavity density was similar between watersheds, but the TSI watershed had a higher density of animal cavities while the non-TSI watershed had a higher natural cavity density. Management recommendations include selected TSI of heart-rotted trees on 10- to 15-year intervals to provide snags.

---

## INTRODUCTION

The effects of tree girdling as a silvicultural method of timber stand improvement (TSI) on change in vegetation and wildlife habitat have been well studied (Murphy and Ehrenreich 1965, Metzger and Schultz 1981), but most studies have been short-term. There is a dearth of information on the long-term effects of tree girdling on wildlife habitat, especially on snag and cavity densities. Need for this information in the central Appalachians is increasing due to growing use of intensive forest management practices and loss of forest habitat through surface mining for coal.

Recommendations for management of snag-dependent wildlife species include long rotations of forest stands, retaining snags during harvest, injecting trees with a heart-rot fungus, and providing herbicide-killed trees (McClelland and Frissell 1975, Hardin and Evans 1977, Jackson et al. 1976, Conner 1978, and Evans and Conner 1979). Conner et al. (1981) and McComb and Rumsey (1983) reported the potential value of herbicide-killed trees for woodpeckers' habitat: spraying and injection of herbicides did not appear to adversely affect the tree

as a foraging or nesting site. Girdling of trees may provide foraging or nesting substrate for some species or may adversely affect cavity-dependent wildlife by killing cull trees with natural cavities (Miller and Miller 1980). Hence, this practice may actually limit the number of cavities available to species of cavity-dependent wildlife that require cavities in living trees. Girdling may result in snag characteristics different from those of natural snags, because of the rate and type of fungal decay in the tree (Conner et al. 1981). Normally, girdled trees do not remain standing as long as a natural cavity-tree or snag would stand (Miller and Miller 1980).

This study was undertaken to provide information on snag and cavity densities in TSI and non-TSI stands in a mixed mesophytic forest. The objectives were to quantify the long-term effects of girdling trees on snag and cavity densities and to determine the density of potentially usable snags and cavities per tree species.

## STUDY AREA

The study was established in 2 watersheds on the University of Kentucky's Robinson Forest, located in Breathitt, Perry, and Knott Counties, Kentucky. Robinson Forest is a mixed mesophytic forest in the Cumberland Plateau region of Kentucky (Braun 1950). Xeric sites are dominated by scarlet oak (*Quercus coccinea*), black oak (*Quercus velutina*), chestnut oak (*Quercus prinus*), white oak (*Quercus alba*), red maple (*Acer rubrum*) and sourwood (*Oxydendrum arboreum*). Mesic sites are dominated by eastern hemlock (*Tsuga canadensis*), American beech (*Fagus grandifolia*), northern red oak (*Quercus rubra*) and yellow-poplar (*Liriodendron tulipifera*). It is a second-growth forest which was heavily cut prior to 1920. Davenport (1958) reported that extensive TSI, including the girdling

---

<sup>1</sup>This paper was presented at the Snag Habitat Management symposium, Northern Arizona State University, Flagstaff, Arizona 7-9 June 1983. The information reported in the paper (83-8-66) is in connection with Project No. 624 of the Kentucky Agricultural Experiment Station and is published with the approval of the Director.

<sup>2</sup>John J. Moriarty is presently stewardship biologist for the Kentucky Chapter of the Nature Conservancy, Lexington, Kentucky; William C. McComb is assistant professor of forestry and wildlife management at the University of Kentucky, Lexington, Kentucky.



of residual trees, was done from 1955-1960 on an area of the forest which included Falling Rock watershed (TSI treatment in this study) but not Bucklick Hollow (control in this study). Both watersheds encompass a drainage of approximately 80 ha and the altitude is from 300-412 m. Slopes are steep (20 to 100 percent) and characterized by short intermittent streams (Carpenter and Rumsey 1976).

## METHODS

### Study Design

Two 20-ha study areas were established, one in the Bucklick (control) watershed and the other in the Falling Rock (TSI) watershed. Each study area consisted of about 50 percent north slopes and 50 percent south slopes. A 50-point grid was established on an 80 x 50 m spacing and a 0.05-ha circular plot was established at each point.

Girdled trees, snags, and cavities were counted on each plot during the winter so that foliage would not obscure any cavity entrances. Cavity-trees and snags were identified to species whenever possible.

Vegetation over 10 cm dbh was tallied on each plot by species and diameter was measured to the nearest 0.1 cm. Basal area and density of each species were summed by plot. Relative dominance was calculated for each species on each watershed. Student's t-test was used to compare stand structural characteristics between watersheds. Linear correlation was used to investigate associations between various combinations of structural attributes on the study areas.

## RESULTS AND DISCUSSION

### Overstory

There were more trees ( $P < 0.05$ ) on Falling Rock (TSI) (958 stems/ha) than Bucklick (non-TSI) (563 stems/ha). This was reflected in a higher average basal area estimate on Falling Rock (46.1 m<sup>2</sup>/ha) than on Bucklick (34.2 m<sup>2</sup>/ha). Differences between watersheds were probably due to the TSI practices on Falling Rock in the 1950's. There were more trees greater than 20 cm on Bucklick than on Falling Rock (fig. 1). Release of suppressed individuals following TSI allowed increased growth and higher stand density.

Tree species composition was similar between watersheds. There were 33 species on the Falling Rock watershed and 32 species on the Bucklick watershed; 30 species were common to both areas.

### Snag and Cavity Densities

We found no girdled trees on Bucklick, but an average of 8.4 girdled trees per ha remained standing on Falling Rock (table 1). Snags were more evenly distributed among diameter classes on Falling Rock than on Bucklick (fig. 2). The density

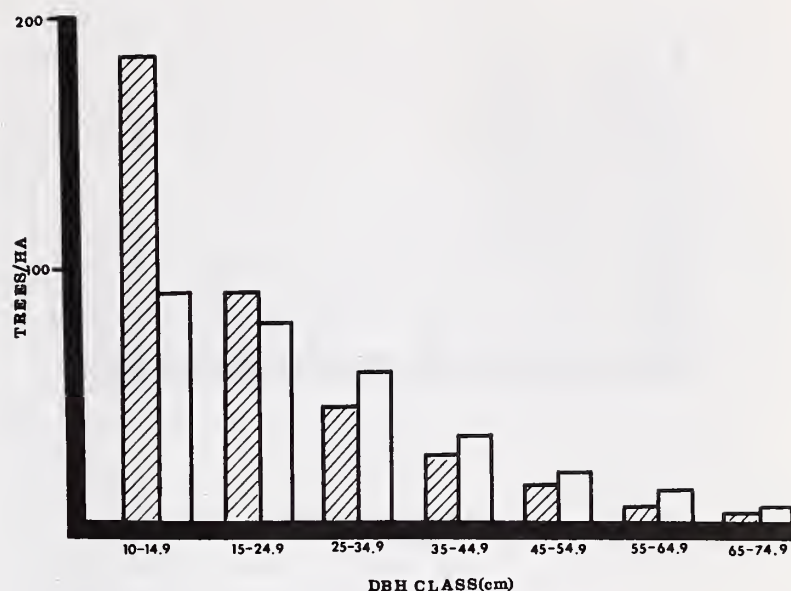

Figure 1.--Tree distribution by diameter class on TSI'ed (cross-hatched) and non-TSI'ed (open bars) watersheds, Breathitt County, Kentucky 1981, 20 years post-treatment.

Table 1.--Cavity and snag densities per hectare for two watersheds in Robinson Forest, Breathitt County, Kentucky, 1981.

Cavity Type	Watershed			
	Falling Rock (N=50) (TSI)		Bucklick (N=50) (Control)	
	Mean	S.E.	Mean	S.E.
Cavities				
Animal	15.6	0.51 *	10.4	0.46
Natural	6.0	0.34 *	12.8	0.39
Basal	8.8	0.34 *	7.2	0.30
Total	30.4	1.19	30.4	1.15
Snags				
Girdled <sup>1</sup>	8.4	0.37 *	0.0	0

\*  $P < 0.01$

<sup>1</sup> Included within snag densities; 20 years post-treatment.

of girdled trees on Falling Rock was correlated with natural snag density ( $r = +0.55$ ,  $P < 0.01$ ) and total snag density (girdled trees and snags) was weakly correlated with the number of animal cavities ( $r = +0.27$ ,  $P < 0.01$ ). Snags provide primary excavators a soft substrate to excavate for nesting, and they provide a foraging substrate. Additional foraging substrate was available on Falling Rock in the form of snags 2.5 to 10 cm dbh. More of these small snags were found on Falling Rock ( $\bar{X} = 46.4$  stems/ha) than on Bucklick ( $\bar{X} = 20.4$  stems/ha) probably as a result of natural mortality in the TSI released stems. Large residual girdled trees provided more potential nest sites and feeding substrate for large cavity-nesters, such as pileated woodpeckers (*Dryocopus pileatus*), without adversely affecting availability of nest sites for small cavity-nesters (fig. 2). It should be noted however, that not all of the nest sites available would meet the requirements of large primary cavity-nesters due to a



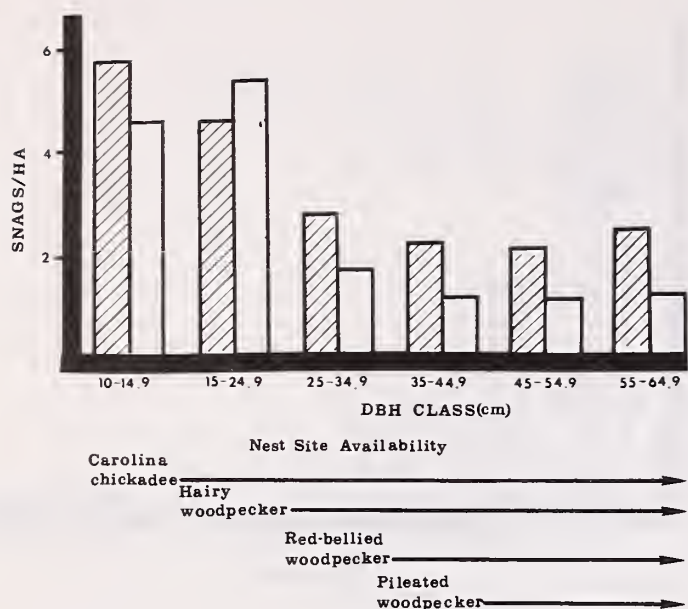

Figure 2.--Distribution of snags by diameter class on TSI'ed (cross-hatched) and non-TSI'ed (open bars) watersheds, Breathitt County, Kentucky, 1981, 20 years post-treatment. Nest site availability is also depicted for four common primary cavity-nesters.

spongy outer layer of the girdled snag. Pileated woodpecker nest holes were observed in several residual girdled trees on Falling Rock. Girdled trees infected with heart-rot prior to girdling may provide suitable nest sites.

There were more natural snags (3/ha) in northern red oak than in any other species (table 2). The highest density of girdled trees was found in American Beech; 83 percent of the beech snags had been girdled. Scarlet oaks and chestnut oaks were also girdled as cull trees on Falling Rock. Gustafson (1946) reported that red maple and American beech were not normally cut during the logging of the early 1900's and residual stems were heavily scarred by poor logging practices.

Standing snags in 1981 may have been different from what was created in the late 1950's because different species have different decay rates (Harmon 1982). Oaks are fast decayers ( $\bar{X}=10\%/yr$ ), while sourwood and pines (*Pinus* spp.) are slow decayers ( $\bar{X}=3.8\%/yr$ ) (Harmon 1982). The slow-decaying species favor the development of a greater number of animal cavities than fast-decaying species because they remain standing longer (Thomas 1979). Thin-barked, noncommercial species such as American beech, red maple, and sourwood, tended to have more natural

Table 2.--The density/10 ha of snags and cavities by tree species for two watersheds in Robinson Forest, Breathitt County, Kentucky, 1981.<sup>1</sup>

Tree Species	Snags		Cavities							
			Animal		Natural		Basal		Total	
	TSI	Non-TSI	TSI	Non-TSI	TSI	Non-TSI	TSI	Non-TSI	TSI	Non-TSI
American beech ( <i>Fagus grandifolia</i> )	48(40) <sup>2</sup>	0	44(36)	0	8(8)	40	52(20)	16	104(64)	76
sourwood ( <i>Oxydendrum arboreum</i> )	4	8	0	0	16	32	8	24	24(0)	76
unknown <sup>3</sup>	16(4)	20	20(12)	40	4(4)	0	4(4)	0	28(20)	40
red maple ( <i>Acer rubrum</i> )	0	0	32	0	4	4	4	12	40(0)	16
white oak ( <i>Quercus alba</i> )	12(4)	8	12(4)	8	12	0	0	0	24(4)	8
blackgum ( <i>Nyssa sylvatica</i> )	4	0	12	0	0	8	4	4	16(0)	12
scarlet oak ( <i>Quercus coccinea</i> )	20(12)	8	0	4	4	8	4	4	8(0)	16
yellow-poplar ( <i>Liriodendron tulipifera</i> )	12	4	8	4	0	4	8	0	16(0)	8
black oak ( <i>Quercus velutina</i> )	12	8	4	16	0	0	0	0	4(0)	16
northern red oak ( <i>Quercus rubra</i> )	16	12	0	12	0	4	0	0	0(0)	16
chestnut oak ( <i>Quercus prinus</i> )	8(4)	12	4(4)	0	0	4	4(4)	0	12(12)	0
post oak ( <i>Quercus stellata</i> )	0	4	0	0	0	8	0	8	0	16
others <sup>4</sup>	28(12)	64	16	20	8	20	0	4	24(0)	44
TOTAL	176(76)	148	140(60)	104	56(12)	132	88(28)	72	300(100)	308

<sup>1</sup>Data presented are based on 50 0.05-ha samples per watershed.

<sup>2</sup>Total with value for girdled trees that remained standing after 30 years indicated parenthetically.

<sup>3</sup>Snags that could not be identified to genus.

<sup>4</sup>Taxa with <2 cavities per 2.5 ha: *Betula lenta*, *Carya glabra*, *Carya* spp., *Cornus florida*, *Magnolia tripetala*, *Pinus* spp., *Quercus* spp., *Robinia pseudoacacia*, *Tilia* spp. and *Ulmus rubra*.



and basal cavities (table 2) caused by logging and fire injuries, which allow decaying agents to enter the tree and form cavities.

Density of snags >10 cm (including girdled trees) was significantly higher ( $P < 0.05$ ) on Falling Rock (18.0 snags/ha) than on Bucklick (14.8 snags/ha) (table 1). These densities are lower than the densities found by McComb and Muller (1983) for a 30-year-old second-growth forest (85.6 snags/ha) in southeastern Kentucky. A managed forest in Connecticut had a density of 14.8 snags/ha (McComb and Noble 1980). McComb and Muller (1983) found a density of 44.2 snags/ha for an old-growth forest in southeastern Kentucky. The variation in snag densities between old-growth and second-growth forests can be explained by stand histories. The high snag density reported by McComb and Muller (1983) may be due to rapid regrowth with minimal site disturbance after cutting and subsequently greater annual mortality in the 30-year-old stand than in uncut stands. Robinson Forest was subjected to frequent fires immediately following cutting, and this disturbance probably resulted in slow regrowth and low annual mortality after 50 years.

Total cavity density for Falling Rock and Bucklick averaged 30.4 cavities/ha, but types of cavities differed between watersheds (table 1). Falling Rock had more ( $P < 0.05$ ) animal cavities (15.6/ha) than Bucklick (10.4/ha) possibly because snags were more abundant on Falling Rock than Bucklick. Carolina chickadees (*Parus carolinensis*) frequently used the soft, remaining girdled snags but cavities created by chickadees may not be used by many other cavity-nesting species because of the small cavity size (Thomas 1979). Natural cavities were significantly ( $P < 0.01$ ) more abundant on Bucklick (12.8/ha) than Falling Rock (6.0/ha). The girdling of the large hollow trees would accelerate falling due to lack of internal support. McComb and Rumsey (1983) reported similar reduction in natural cavity density following forest herbicide application at Robinson Forest. The recommended cavity density for maintaining viable populations of cavity-dependent species in the oak-hickory forest is 10 cavities/ha (Hardin and Evans 1977); lower than the cavity densities found on Falling Rock and Bucklick. Cavity densities on Falling Rock or Bucklick were higher than reported in other studies (McComb and Noble 1980, Carey and Healy 1981), but this may be due to differences in species composition, logging practices, or climatic conditions, all of which affect the suitability of a tree or snag for cavity formation.

#### MANAGEMENT IMPLICATIONS

Timber stand improvement by girdling provided additional feeding substrate and some nesting sites for primary cavity-nesters 20-30 years after treatment. Tree girdling reduced natural cavity abundance but increased animal cavity density. Secondary cavity users, such as barred owls (*Strix varia*), Virginia opossums (*Didelphis virginiana*), and gray squirrels (*Sciurus carolinensis*), which prefer natural tree cavities to animal-made cavities, may not benefit from TSI unless provisions are made to leave an adequate number of natural-cavity trees for these species.

Girdling of trees, particularly those which contain heart-rot, would be of benefit to some primary cavity-nesters and secondary cavity-nesters that prefer animal cavities. Release of suppressed trees by girdling large (>40 cm dbh) unmerchantable trees, particularly those with heart-rot, results in additional potential nesting sites for primary nesters, and long-term availability of feeding substrate due to natural mortality in the released trees. To supply a sustained yield of snags for cavity-nesters in 50-year-old second-growth central Appalachian stands we suggest girdling 1 or 2 heart-rot infected trees > 40 cm dbh per hectare on 10- to 15-year intervals. Natural mortality of TSI released stems will provide small and medium sized snags. At least 2 large, natural cavity-bearing trees per hectare should be left untouched to provide nesting sites for species preferring natural tree cavities. In the long run, this should provide a more equitable distribution of small, medium, and large diameter snags while still maintaining natural cavity density.

#### ACKNOWLEDGEMENTS

We thank T.K. Sheehan, C.L. Chambers, D. Roberts, J.W. Moriarty for assistance with field work; M. Noble, A.B. Marshall and the Robinson Forest staff for technical support; and C. Rowell, C.J. Liu, and R.N. Muller for assistance with data analysis; and B.A. Thielges, R.N. Muller, G.A. McPeck, and D.B. Hill for reviewing an early draft of the manuscript.

#### LITERATURE CITED

- Braun, E.L. 1950. Deciduous forests of eastern North America. Blakiston Co. Philadelphia. 596 pp.
- Carey, A.B. and W.M. Healey. 1981. Cavities in trees around spring seeps in the maple-beech-birch forest type. U.S. Dep. Agric. For. Serv. Res. Paper NE-480. 7 pp.
- Carpenter, S.B. and R.L. Rumsey. 1976. Trees and shrubs of Robinson Forest, Breathitt County, Kentucky. *Castanea* 41:277-282.
- Conner, R.N. 1978. Snag management for cavity-nesting birds. pp. 120-128. *In: Proceedings of the workshop management of southern forests for nongame birds*, DeGraaf, R.M. (ed.). U.S. Dep. Agric. For. Serv. Gen. Tech. Rep. SE-14.
- \_\_\_\_\_, J.G. Dickson and B.A. Locke. 1981. Herbicide-killed trees infected by fungi: Potential cavity sites for woodpeckers. *Wildl. Soc. Bull.* 9:308-310.
- Crawford, H.S. 1971. Wildlife habitat changes after intermediate cutting for even-aged oak management. *J. Wildl. Manage.* 35:275-286.
- Davenport, O.M. 1958. Timber management and research. p. 75. *In: Results of research in 1957*. Ky. Agric. Exper. Stn. Ann. Rep. 90 pp.
- Evans, K.E. and R.N. Conner. 1979. Snag Management. pp. 214-225. *In: Proceedings of the workshop*



- of management of northcentral and northeastern forests for nongame birds. DeGraaf, R.M. and K.E. Evans (eds.). U.S. Dep. Agric. For. Serv. Gen. Tech. Rep. NC-51. 268 pp.
- Gustafon, R.O. 1946. Forest fires, basal wounds, and resulting damages to timber in an eastern Kentucky area. Ky. Agric. Exper. Stn. Bull. 493. 15 pp.
- Hardin, K.I. and K.E. Evans. 1977. Cavity nesting birds in the oak-hickory forest...a review. U.S. Dep. Agric. For. Serv. Gen. Tech. Rep. NC-30. 23 pp.
- Harmon, M.F. 1982. Decomposition of standing dead trees in the southern Appalachian mountains. *Oecologia* 52:214-215.
- Jackson, J.A., R. Weeks and R. Shindala. 1976. The present status and future of red-cockaded woodpeckers in Kentucky. *Ky. Warbler* 52:75-80.
- McClelland, B.R. and S. Frissell. 1975. Identifying forest snags useful for hole-nesting birds. *J. For.* 73:414-417.
- McComb, W.C. and R.N. Muller. 1983. Snag densities in old-growth and second-growth Appalachian forests. *J. Wildl. Manage.* 47:376-382.
- \_\_\_\_\_, and R.E. Noble. 1980. Effects of single-tree selection cutting upon snag and natural cavity characteristics in Connecticut. *Trans. Northeast Sec. Wildl. Soc.* 37:50-57.
- \_\_\_\_\_, and R.L. Rumsey. 1983. Characteristics and cavity-nesting bird use of picloram-created snags in the central Appalachians. *So. J. Appl. For.* 7:34-37.
- Metzger, R. and J. Schultz. 1981. Spring ground layer vegetation 50 years after harvesting in northern hardwood forests. *Am. Midl. Nat.* 105:44-50.
- Miller, E. and D.R. Miller. 1980. Snag use by birds. pp. 337-356. *In: Workshop proceedings: Management of western forests and grasslands for nongame birds.* R.M. DeGraaf (ed.), U.S. Dep. Agric. For. Serv. Gen. Tech. Rep. INT-86. 535 pp.
- Murphy, D.A. and J.A. Ehrenreich. 1965. Effects of timber harvest and stand improvement of forage production. *J. Wildl. Manage.* 29: 734-739.
- Thomas, J.W. (ed.). 1979. *Wildlife habitats in managed forests, the Blue Mountains of Oregon and Washington.* U.S. Dep. Agric. Handb. 553. 512 pp.



# The Effect of Firewood Removal on Breeding Bird Populations in a Northern Oak Forest<sup>1</sup>

John V. Dingledine and Jonathan B. Haufler<sup>3</sup>

---

Abstract.--Breeding bird populations and snags were examined in relation to a controlled firewood removal in a northern oak forest in Michigan. Snag densities were significantly decreased by the firewood removal, but a complete reduction did not occur due to new snag generation and the presence of certain snags unsuitable as firewood. Cavity-nesting bird species were not decreased by the firewood removal due in part to the utilization of live trees or dead portions of live trees as nest sites. Snags did provide important foraging sites, but their loss did not cause identifiable decreases in the use of the study areas in this investigation.

---

## INTRODUCTION

Past reductions in fossil fuels have led to a greater use of alternate energy sources. Wood, as a home heating fuel, continues to increase in popularity. For example, the number of firewood cutting permits issued by the White Cloud Ranger District of the Manistee National Forest has risen 414% between 1978 and 1982. Increasing demand for firewood poses a potential threat to the wildlife that utilize snags for food or cover. Many species of birds have been shown to use snags for numerous purposes including nesting, roosting, perching, and storing food (Thomas et. al. 1979, Miller and Miller 1980). The role of snags as nesting and foraging sites for the cavity-nesting bird species has been the subject of a number of recent studies (Conner et. al. 1975, Scott 1978, Conner 1980, Mannon, Meslow, and Wright 1980). Nest sites are generally considered a primary limiting factor in determining densities of these species. This study examined the impact of firewood removal on breeding bird populations and

habitat, especially snag densities and characteristics, within a northern oak forest in Michigan.

## SITE DESCRIPTION

Six, 15 ha rectangular study plots were established within the White Cloud Ranger District of the Huron-Manistee National Forest, 12 km west of Big Rapids, Michigan. Plot boundaries were designated to make all plots as uniform in stand characteristics as possible. The distance between plots ranged from 200 m to over 1 km. Stands, consisting mainly of mature red oak (Quercus rubra) and white oak (Q. alba) along with smaller percentages of red maple (Acer rubrum), black oak (Q. velutina), and big-toothed aspen (Populus grandidentata), covered the study area. Midstory vegetation was comprised of witchhazel (Hamamelis virginiana), serviceberry (Amelanchier spp.), and sassafras (Sassafras varifolium).

Extensive vegetative sampling was conducted on each plot to quantify characteristics such as stem densities and vegetative cover. The absolute density of woody species >5 cm d.b.h. averaged  $528 \pm 73$  per ha, with a mean basal area of  $25.5 \pm 3.5$  m<sup>2</sup> per ha. Importance values based on relative density, relative frequency, and relative dominance averaged  $102 \pm 3.4$  for white oak,  $84.7 \pm 10.5$  for red oak,  $57.8 \pm 10.7$  for red maple,  $28.9 \pm 4.1$  for black oak, and  $13.8 \pm 4.9$  for big-toothed aspen. The % vegetation cover measured in three height strata (<1 m, 1-7 m, >7 m) was used to calculate foliage height diversity (McArthur and McArthur 1961) which averaged  $0.87 \pm 0.02$ . The average age of the stands was 65 years.

---

<sup>1</sup>Paper presented at the Snag Habitat Management Symposium. (Northern Arizona University, Flagstaff, June 7-9, 1983).

<sup>2</sup>Journal Article No. 10859 from the Michigan Agricultural Experiment Station.

<sup>3</sup>John V. Dingledine is a graduate assistant in wildlife ecology and Jonathan B. Haufler is a assistant professor of wildlife ecology, Michigan State University, East Lansing, MI.



## METHODS

Three of the 6 study plots were randomly selected for treatment while the other three served as controls. In this study, treatment consisted of the removal of all dead standing or dead and down wood as per National Forest Service policy regarding firewood removal. In September 1981, the center 8 ha of each treatment plot was cleared of all firewood. A small number of the more rotten snags were considered unsuitable as firewood and were not removed to simulate conditions found on areas open to the public for firewood cutting. The uncut 50 m border zone served as a buffer and made it possible to examine any changes in bird distributions such as possible clumping of territories around the treatment area.

Breeding bird population densities were determined by the spot-mapping method following I.B.C.C. recommendations (1970). Birds were censused once before firewood removal in the breeding season of 1981 and once again following treatment during the 1982 season. At least 8 surveys were made of each plot each year between 10 May and 23 June. Census takers and their routes over the plots were regularly varied to control observer bias and compensate for changes in bird detectability with time of day. Following the censusing each morning, cavity-nesting birds were located and followed to determine active nest sites.

A survey of all snags >18 cm d.b.h. was conducted both years to determine snag densities and characteristics. Each snag in this size class was examined and the features of tree species, d.b.h., height, % bark cover, top condition, and number of branches were recorded. The presence of woodpecker foraging evidence and cavities was also noted.

These features were used to categorize snags into five different stages. These stages ranged from snags with 100% bark cover, intact top, and many branches to snags with 0-5% bark cover, broken tops and no branches (Fig. 1).

The density of snags in the 5-18 cm d.b.h. size class was determined by a random sampling method using 50 m x 50 m quadrats. Physical characteristics of snags in this size class were not recorded. Bird population parameters and snag densities were tested for significant differences by the use of t-tests.

## RESULTS

A total of 915 snags >18 cm d.b.h. were surveyed in 1981 at a mean density of  $10.2 \pm .89$  snags per ha. The density of snags in the 5-18 cm d.b.h. size class averaged  $45.4 \pm 5.9$  per ha. The average d.b.h. of the snags in the larger size class was  $24.6 \pm 0.64$  cm and ranged up to 50 cm. Woodpecker foraging evidence appeared on  $44.6 \pm 2.1\%$  of the larger snags and more specifically on  $74.5 \pm 2.8\%$  of the aspen snags. Only  $8.8 \pm 1.9\%$  of the snags examined in 1981 held cavities. None of the above factors were significantly different between controls and treatments in 1981, prior to firewood removal.

The majority of the snags present on the study area in 1981 were in the early stages of snag succession (Fig. 2) based on the categorization scheme presented earlier. Few snags characterized by stage 5 were present. The % of snags with foraging evidence or cavities, however, was greater in the later stages (Fig. 3).

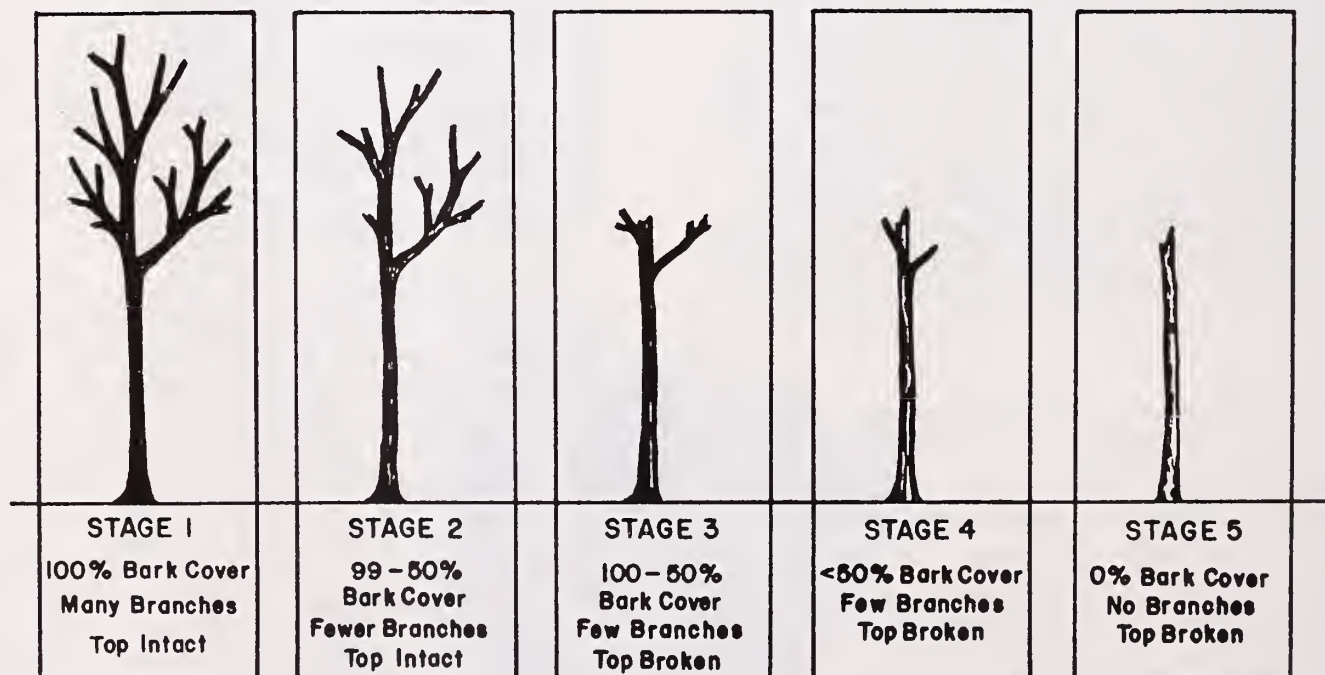

Figure 1. Description of the stages of snag decay based on physical characteristics of bark cover, top condition, and number of branches.

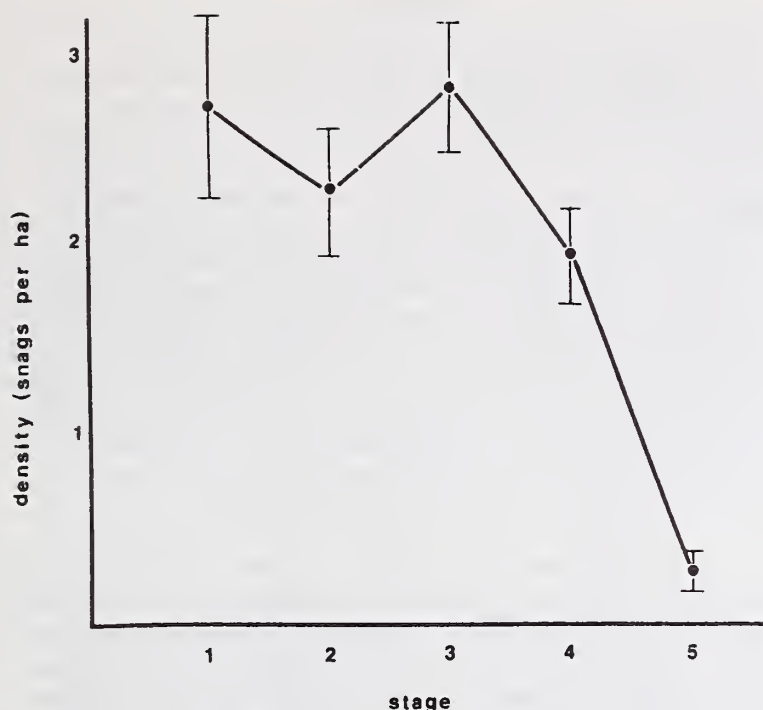

Figure 2.--Mean densities and standard errors of snags (>18 cm d.b.h.) by stage in 1981 in northern oak stands in Michigan.

Densities of snags (>18 cm d.b.h.) on treatment plots decreased significantly following firewood removal (Fig. 4). Snag densities over the entire treatment plot were reduced an average of  $34.7 \pm 6.7\%$  while densities specifically within the treatment zone were decreased an average of  $69.1 \pm 3.4\%$ . Snags (5-18 cm d.b.h.) were also significantly decreased by firewood removal to  $35 \pm 7.8\%$  of their original density of the entire plot. Total reductions in snag numbers were not achieved due the generation of new snags and the presence of a small number of snags that were unsuitable as firewood.

The aspect of snag generation was evident on control plots as well. All control plots showed a net increase in snag (>18 cm d.b.h.) densities with the exception of plot 5, where the net change in density was  $-0.37\%$  due to the occurrence of some uncontrolled, non-project related firewood cutting. The average % change in snag densities on the other 2 control plots was  $18.75 \pm 4.15\%$ . Based on data collected on the two undisturbed control plots, live trees were becoming snags at a mean rate of  $2.1 \pm 0.6$  per ha.

Fifteen species of breeding birds were included in the census of 1981 and 1982 (Table 1). The eastern wood pewee was the most abundant species followed by the red-eyed vireo. Six species of cavity-nesting birds were observed, but only three, the hairy woodpecker, the white-breasted nuthatch, and the great-crested flycatcher were found on all plots both years. Cavity-nesters made up 14.9% and 12.5% of the total population in 1981 and 1982, respectively. Prior to firewood removal, breeding bird populations averaged  $189.5 \pm 5.5$  individuals per 40 ha and were not significantly different between control and treatment plots (Table 2). Following the treatment, bird populations on control plots were significantly

greater ( $P < 0.10$ ) than those on treatment plots. These differences were due mainly to greater numbers of scarlet tanagers and ovenbirds. Densities of cavity-nesting birds on treatment plots were not significantly different from control plots either before or after firewood removal. Bird species richness and diversity were not affected by the treatment.

Nest sites of all cavity-nesting birds were not successfully located, but at least one nest site was located for each cavity-nesting species with the exception of the great-crested flycatcher (Table 3). Most nests found were those of the hairy woodpecker and the white-breasted nuthatch. The low number of nest sites located for the downy woodpecker, black-capped chickadee, and red-headed woodpecker corresponded to the infrequent occurrence of these species on the study plots. Oaks were selected the most frequently by all cavity-nesting species except for the hairy woodpecker which more often selected aspen. Eighty-six % of all nests were located in live trees or dead portions of live trees and only 14% of the nests were located in snags.

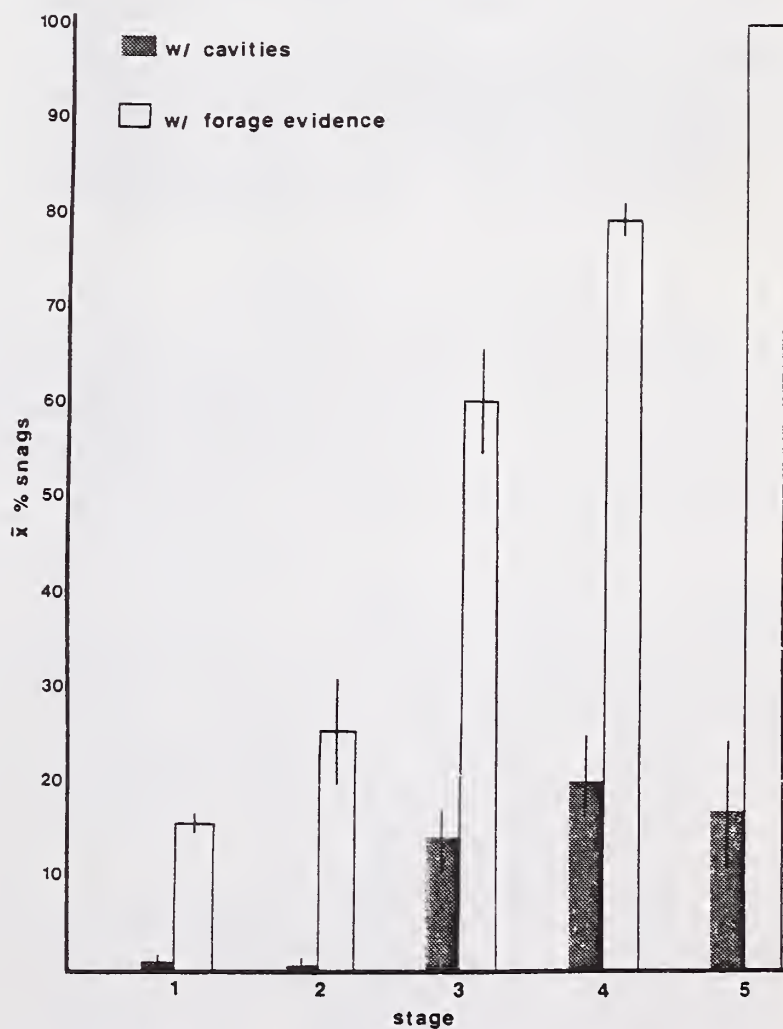
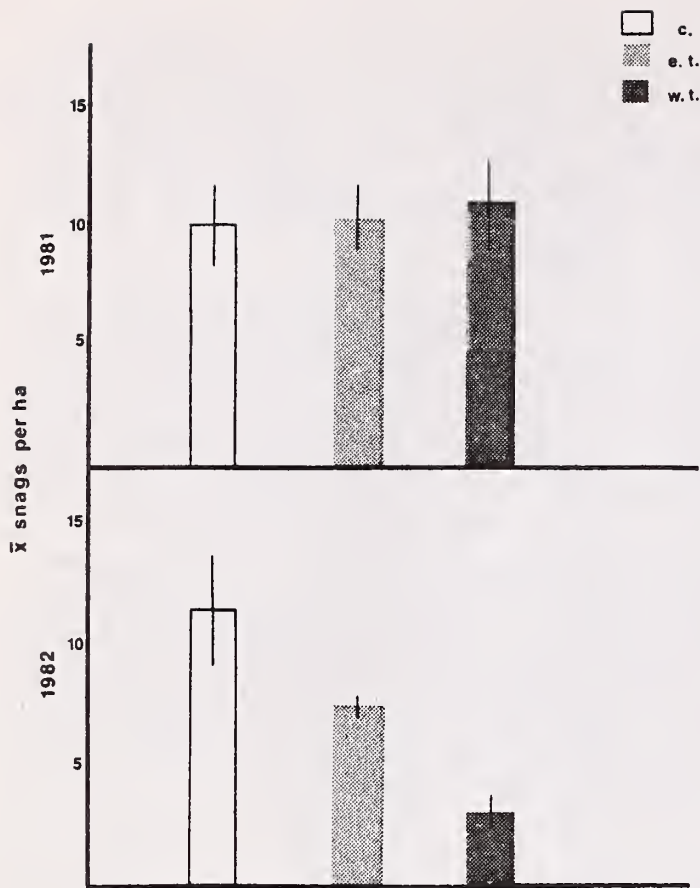

Figure 3.--Mean and standard error of snags (>18 cm d.b.h.) with foraging evidence and cavities in 1981 in oak stands in Michigan.



DISCUSSION



\*significantly different (P<0.02) from controls.

Figure 4.--Mean snag (>18 cm d.b.h.) densities and standard errors for control plots (c.), entire treatment plots (e.t.), and within the treatment area (w.t.) before and after firewood removal in oak stands in Michigan.

Results of the bird census and snag survey conducted in 1981 confirmed that control and treatment plots did not differ in terms of snag densities or bird populations prior to firewood removal. Vegetative sampling completed during the study period also showed no major differences in the plant community, so that the only significant difference in bird habitat between control and treatment plots in 1982 was the decrease in snag densities resulting from the firewood cutting. The significantly (P<0.10) lower density of breeding birds on the treatment plots in 1982 is difficult to relate to the reduction in numbers of snags because the species accounting for most of the difference were not cavity-nesters.

The absence of an expected decrease in cavity-nesting bird species may have been due to several factors. First, most of the cavity-nesting birds inhabiting the study plots preferred to nest in live trees or dead portions of live trees. The preference for live trees exhibited by the hairy woodpecker and the white-breasted nuthatch has been noted by other authors (Kilhorn 1968, Lawrence 1966). The use of live aspen by hairy woodpeckers follows with the observations of Lawrence (1966) but is in contrast to those of Conner (1976). The lack of data collected for the great-crested flycatcher made it impossible to determine whether it was more often selecting cavities in live trees or snags, but regardless, detections of this species did not decrease after firewood removal. Secondly, snag densities present on the study plots before treatment were considerably above levels recommended by Evans and Conner (1979) for woodpecker species typical of this vegetation type, so that significant reductions in snag numbers may have still left enough remaining snags to support the populations. The average snag

Table 1.--Average numbers of breeding birds by species before and after firewood removal on 15 ha study plots in northern oak stands in Michigan.

Common name (Scientific name)	1981		1982	
	Control X̄ ± S.E.	Treatment X̄ ± S.E.	Control X̄ ± S.E.	Treatment X̄ ± S.E.
Red-headed woodpecker ( <i>Melanerpes erythrocephalus</i> )	0.67±0.67	0.67±0.67	-	-
Hairy woodpecker ( <i>Picoides villosus</i> )	3.3±0.67	2±0	2±0	2±0
Downy woodpecker ( <i>Picoides pubescens</i> )	-	-	0.67±0.67	-
Great-crested flycatcher ( <i>Myiarchus crinitus</i> )	2.6±0.67	2.6±0.67	2±0	2.6±0.67
Eastern wood pewee ( <i>Contopus virens</i> )	18.7±0.67	18.7±1.7	16.7±2.9	16.7±1.3
Blue jay ( <i>Cyanocitta cristata</i> )	1.3±0.67	4.6±0.67	6.7±0.67	4.6±1.3
Common crow ( <i>Corvus brachyrhynchos</i> )	-	-	-	0.67±0.67
Black-capped chickadee ( <i>Parus atricapillus</i> )	-	1.3±1.3	2±1.1	0.67±0.67
White-breasted nuthatch ( <i>Sitta carolinensis</i> )	4±0	4±1.1	4±0	4±1.1
American robin ( <i>Turdus migratorius</i> )	0.67±0.67	0.67±0.67	1.3±0.67	-
Yellow-throated vireo ( <i>Vireo flavifrons</i> )	-	-	0.67±0.67	1.3±0.67
Red-eyed vireo ( <i>Vireo olivaceus</i> )	15.3±0.67	10.7±2.4	16.7±1.3	14.6±1.3
Ovenbird ( <i>Seiurus aurocapillus</i> )	9.3±1.8	10.7±1.8	12±1.1	8.7±3.3
Scarlet tanager ( <i>Piranga olivacea</i> )	6.7±1.3	8±2.3	12±1.1	6.7±1.8
Rose-breasted grosbeak ( <i>Pheucticus ludovicianus</i> )	8.7±1.8	8.7±1.8	10±2	11.3±1.8



Table 2.--Breeding bird community characteristics before and after firewood removal on study plots in northern oak stands in Michigan.

	1981		1982	
	Treatment $\bar{X} \pm S.E.$	Control $\bar{X} \pm S.E.$	Treatment $\bar{X} \pm S.E.$	Control $\bar{X} \pm S.E.$
Bird density (40 ha)	194 $\pm$ 4.6	189 $\pm$ 6.3	196 $\pm$ 9.4*	230 $\pm$ 8.6*
C.N.B. density (40 ha)	28 $\pm$ 1.8	29 $\pm$ 1.8	25 $\pm$ 4.7	28 $\pm$ 3.5
Species richness	10 $\pm$ 0.6	9.7 $\pm$ 0.3	10 $\pm$ 0.0	10.7 $\pm$ 0.9
Species diversity <sup>1</sup>	2.04 $\pm$ 0.06	2.00 $\pm$ 0.05	2.07 $\pm$ 0.11	2.07 $\pm$ 0.08

\*significantly different (P<0.10)

<sup>1</sup>) calculated by the Shannon Weaver Index

d.b.h. was also within the ranges used by woodpeckers with the exception of the pileated woodpecker (*Drycopus pileatus*), although this species was observed foraging on the plots occasionally.

The near total absence of the downy woodpecker may have been due to the high percentage of snags in the early stages of snag succession, which may have been too "hard" for this species to excavate (Conner 1978). The higher percentage of older snags having cavities points to the increasing value of a snag as it ages. Since firewood cutters normally prefer the harder snags in an early stage of snag decay, the impact of the removal on some species may become more pronounced with time when no new snags will be left to age.

The importance of snags as foraging sites was evident by the high number exhibiting signs of use. Aspen species, in particular, appeared important in this regard. Due to the poor quality of aspen as firewood, it is usually less often selected by firewood cutters, and was often the species of snag not cut in this study due to its rapid decay. However, as the stands investigated age, aspen will become less frequent due to successional change, and other species of snags, such as oaks, will become more important as foraging sites. Again, the high % of foraging evidence on snags in the later stages of decay may mean that the effect of firewood removal may become greater with time.

Table 3.--Condition of nest trees used by the cavity-nesting bird species in northern oak stands in Michigan.

	Live tree	Dead portion of live tree	Dead tree
Hairy woodpecker	4	0	0
White-breasted nuthatch	6	0	1
Downy woodpecker	0	1	0
Black-capped chickadee	1	0	0
Red-headed woodpecker	0	0	1

The generation of new snags was clearly evident on the control plots and is a factor which may reduce the impact of firewood removal. Although the trees that died and became snags between 1981 and 1982 were probably not very suitable for cavity-nesting species and also provided poor foraging sites, their value to cavity-nesters will increase in time if they are not removed by additional firewood cutting. However, it would take approximately four to five years for snag generation to produce recommended numbers of snags (Evans and Conner 1979) and many more years before these snags decayed to the preferred stages.

A final consideration in the results of the study related to the dimensions of the study plots. Although a 15 ha study plot size approached the limit of managability of the project, large numbers of cavity-nesters important in showing statistically significant changes did not occur in the study plots due to the large territory size of most cavity-nesting species.

#### MANAGEMENT IMPLICATIONS

Results of this study suggest that small areas within this vegetation type could be harvested for firewood without significant reductions in cavity-nesting bird populations due to the extensive use of live trees or dead portions of live trees for nesting by these species. This does not mean that the loss of snags over large areas would not decrease bird numbers, but that blocks up to 8 ha in size may be intensively harvested over a short time span. Cavity-nesting species in other vegetation types may show a different response if they are more dependent on snags, as has been suggested by other authors, than the species observed in this study. However, even in northern oak forests, continual harvesting of newly formed snags may be detrimental because eventually no snags in the later stages of decay will be present.

The importance of aspens as foraging sites as well as nesting sites in both live and dead trees indicates that at least small percentages of this or other "soft" species should be encouraged in forest stands. Timber harvesting and timber stand improvement practices might be modified to include such considerations.



LITERATURE CITED

- Connor, R.N., R.G. Hooper, H.S. Crawford, and A.S. Mosby. 1975. Woodpecker nesting habitat in cut and uncut woodlands in Virginia. *J. Wildl. Manage.* 39(1):144-150.
- Conner, R.N. 1978. Snag management for cavity nesting birds. Pages 120-128 in R.M. DeGraaf ed. Management of Southern forests for nongame birds. U.S. Dept. Agric. For. Serv. GTR SE-14, 176 pp.
- Conner, R.N. 1980. Foraging habitats of woodpeckers of Southwestern Virginia. *J. Field. Ornithol.* 51(2):119-127.
- Evans, K.E. and R.N. Conner. 1979. Snag management. Pages 214-225, in R.M. DeGraaf ed. Management of north central and northeastern forests for nongame birds. U.S. Dept. Agric. For. Serv. GTR NC-51. 268 pp.
- Lawrence, L. Dek. 1966. A comparative life-history study of four species of woodpeckers. *A.O.U. Ornithol. Manage. No. 5.* 156 pp.
- Kilham, L. 1968. Reproductive behavior of white-breasted nuthatches. *Auk* 85(3):477-492.
- MacArthur, R.H., and J.W. MacArthur. 1961. On bird species diversity. *Ecology* 42:594-598.
- Mannon, R.W., E.C. Meslow, and H.M. Wight. 1980. Use of snags by birds in Douglas-fir forests, Western Oregon. *J. Wildl. Manage.* 44(4):787-797.
- Miller, E., and D.R. Miller. 1980. Snag use by birds. Pages 337-355 in R.M. DeGraaf ed. Management of western forests and grasslands for nongame birds. U.S. Dept. Agric. For. Serv. GTR INT-86, 535 pp.
- Scott, V.E. 1978. Characteristics of ponderosa pine snags used by cavity-nesting birds in Arizona. *J. For.* 76(1):26-28.
- Thomas, J.W., R.G. Anderson, C. Maser, and E.L. Bull. 1979. Snags. Pages 60-77 in J.W. Thomas, ed. wildlife habitats in managed forests the Blue Mountains of Oregon and Washington. U.S. Dep. Agric. For. Serv. Handb. 553. Washington, D.C. 512 pp.



# Management of Snags and Den Trees in Missouri — A Process<sup>1</sup>

Russ Titus<sup>2</sup>

---

**ABSTRACT.**--The Missouri Department of Conservation and Mark Twain National Forest have been reviewing and refining standards and guides for managing wildlife habitat. An important part of this effort has been to more clearly define the biological basis for dens and snags and to develop management guidelines. A committee was assigned to review available literature on 89 species of birds, mammals, amphibians and reptiles known to require snags and/or den trees to meet their life history requisites in Missouri. Data on these species such as territory size, maximum populations/100 acres, and den tree characteristics such as diameter at breast height, cavity height, and number of dens per acre required for maximum populations were compiled. The species were then segregated by their use of broad habitat types which were identified as Forest Interior, Semi-open/Open Land, and Wooded Watercourses, referred to as Land Use Patterns (LUPS). Biological requirements were established for each major land use pattern and management techniques recommended for even-age and uneven-age silvicultural systems.

---

## INTRODUCTION

Missouri is in the Middle Mississippi Valley. The land area is 69,674 square miles with 448 being water surface (Steyermark 1963). Elevations range from 230 feet in the southeast to over 1,700 feet in the Ozark Plateau.

Thom and Wilson (1980) classified six major natural divisions in Missouri based on geological history, soils, bedrock geology, topography, plant and animal distribution, presettlement vegetation and other factors. These divisions and man's influence depict the diversity of conditions in Missouri which influence the availability of snags<sup>3</sup> and den trees<sup>4</sup>. These natural divisions represent 1) the influence of big

rivers which created lowland and riparian habitats; 2) the Ozark uplands which are a highly dissected peneplain, heavily forested with oak-hickory and oak-pine types and, 3) the plains of west and north Missouri, glaciated north of the Missouri River, and which once represented 18,474 square miles of tall grass prairie (Schroeder 1981).

Man's influence has greatly altered the forested portions of the prairie and the forested region itself. This activity has had an adverse impact on wildlife species requiring snags and den trees (McComb 1982). Once native to Missouri, the ivory-billed and red-cockaded woodpeckers are extinct or extirpated. These species succumbed to such activities as excessive forest type conversion, unregulated clear-cutting, tree-length skidding, high fuelwood utilization and removal of defective trees. These activities all influence the quality and quantity of snags and den trees.

Biologists in Missouri recently embarked on a joint effort between the Mark Twain National Forest and the Missouri Department of Conservation to review species requirements for snags and den trees, evaluate current management practices and their potential impacts on these species and to recommend management techniques compatible with a variety of management practices.

---

<sup>1</sup>Paper presented at the snag habitat management symposium. (Northern Arizona University, Flagstaff, June 7-9, 1983).

<sup>2</sup>Russell Ray Titus is a Land Management Biologist for the Missouri Department of Conservation, Jefferson City, MO.

<sup>3</sup>A snag is defined as a dead tree at least six inches in diameter breast height (dbh) which is at least ten feet tall.

<sup>4</sup>A den tree is defined as a live tree with a cavity large enough to shelter wildlife.



BIOLOGICAL REQUIREMENTS

Procedure

A list of birds, mammals, reptiles and amphibians requiring snags and den trees was compiled showing that 89 species of wildlife in Missouri require these special habitat characteristics (Schwartz and Schwartz 1959, Conner and Adkisson 1974, Hardin and Evans 1977, Johnson 1977, Brawn 1979, Evans and Conner 1979, DeGraff et al. 1980). Habitat characteristics were compiled and tabled for all species.

The procedure used to define biological requirements was as follows:

1. The list of species was segregated by primary excavators or secondary cavity users.
2. Species were then organized by their preference for broad habitat types. Habitats were based on land use patterns (forest interior, open and semi-open lands, and wooded water courses) which are defined later in the text.
3. Species within land use patterns were further segregated by the size class of tree required to meet their needs. The size classes are greater than 19" dbh, 10-19" dbh and less than 10" dbh.
4. Data on species using each size class were analysed to determine the number of dens and/or snags required per acre. Territory size, maximum population per 100 acres, minimum dens or nest trees required per pair were some of the criteria used to obtain this quantity.
5. The number of snags and/or den trees required per acre for all species at high population levels were summed for each size class of den tree or snag for each land use pattern. Table 1 illustrates these results.

Forest Interior Habitats

Management recommendations for the forest interior land use pattern are based on the biological needs of eight primary excavators and 22 secondary cavity users. These species display a proclivity for contiguous forest cover but will probably exist at low population levels in parts of the state with little forest cover. Best opportunities to manage for these species at high population levels exist in the heavier

<sup>5</sup>This information is available from the author at Box 509, Rolla, Missouri 65401.

TABLE 1.--Optimum densities of snags and/or den trees per acre by three broad habitat types.

Diameter Class	Forest Interior		Semi-open And Open	Wooded Water-Courses
	Dens	Snags	Dens <sup>1</sup>	Dens <sup>1</sup>
Greater Than 19"	1	0	3	2
10" - 19"	4	4	4	14
Less Than 10"	$\frac{2}{7}$	$\frac{2}{6}$	$\frac{3}{10}$	$\frac{9}{25}$

<sup>1</sup>Animal needs are in den trees because snag creation by deadening trees is not generally recommended in these land use patterns.

forested areas. Objectives for snags and den trees are shown in Table 2.

TABLE 2.--Optimum snags and den trees required per acre by size class to attain high populations of all forest interior species and lower management levels.

Diameter Class	Forest Interior		Percent of Optimum				
	Snags <sup>1</sup>	Dens	90%	80%	70%	60%	50%
Greater Than 19"	0	1	0.9	0.8	0.7	0.6	0.5
10" - 19"	4	4	3.6	3.2	2.8	2.4	2.0
Less Than 10"	2	2	1.8	1.6	1.4	1.2	1.0

<sup>1</sup>Snag and den tree requirements are similar because many species would use either live or dead trees and the number of species requiring live den trees approximated the number of species requiring dead trees. Minimum was chosen as half of optimum management with intermediate levels displayed.

Although snag management was integrated with den tree management, it should be emphasized that trees are predominant in the forest interior, therefore, snag objectives should be relatively easy to achieve with the exception of larger diameter trees. Because snags are provided by natural or man induced mortality and do not need the protection den trees require, we can strive for more even distribution and the optimum level of management.

Management guidelines to achieve these goals are:

1. Manage for optimum snag objectives, but do not compromise den tree objectives.
2. Distribution of snags should be even across the landscape (Bull et al. 1980).
3. Management should favor tree species which are relatively rot resistant and long lived<sup>6</sup>.
4. Snag objectives for trees greater than 19" dbh should be met only if there are surplus trees in this diameter class.

#### Semi-open and Open Habitats

Four primary excavators and 21 secondary users show habitat preferences for snags and den trees in the semi-open and open land use patterns (Schwartz and Schwartz 1959, Conner and Adkisson 1974, Hardin and Evans 1977, Johnson 1977, Brawn 1979, Evans and Conner 1979, DeGraff et al 1980.) In this habitat trees may be more critical than in the forest interior.

<u>DBH Class</u>	<u>Optimum No./Ac.</u>
Greater than 19"	3
10" - 19"	4
Less than 10"	3

Most species did not show a preference for den trees or snags in this habitat type. Because live trees may be critical in these conditions, recommendations are that den tree management take precedence over snag management.

In the semi-open and open land patterns, the objectives for snags and den trees can only apply to those acres which can provide enough trees. If a stand has 10 or more trees per acre, it should qualify as having the potential to provide den trees through time.

Two conditions will exist which may influence the manager's objectives for snags and/or den trees. These are stands not productive for commercial timber (noncommercial forest lands) with site index less than 40, and stands of commercial timber (commercial forest land) with site index greater than 40.

When a stand is classified as noncommercial, and has less than 40 square feet of basal area in timber, the value of trees as dens or potential dens warrants management at or near the optimum level. If there is greater than 40 square feet basal area of trees, the optimum

<sup>6</sup>Species information is available from the author at Box 509, Rolla, MO 65401.

level of management can be utilized; however, snag objectives may be met by induced mortality or by natural mortality. Snags on these lands should be selected from surplus stems above den tree objectives. Snag management should never compromise den tree objectives.

When stands are classified commercial forest land and are to be managed for forest products as well as wildlife habitat, the management level for den trees may be reduced below optimum, but should not be lower than 50% of optimum. Species selected for reserve den trees or potential den trees should be selected following guidelines that recommend <sup>7</sup>long lived species which attain large diameters.

When basal area exceeds 40 square feet and the decision is made to sacrifice living trees to provide snags, then protect the best den trees and deaden the residual. Spacing of snags should be distributed throughout each stand. (Bull et al. 1980).

#### Wooded Watercourses

Wooded watercourses are a scarce and disappearing habitat. They occur on alluvial flood plains and benches of streams which have very productive soils for timber as well as agricultural crops.

Wooded watercourses are the least predominant and the highest in quality when compared to other broad habitats. They provide critical habitat for eight of ten primary excavators found in Missouri. Twenty-seven secondary cavity users also utilize cavities in wooded watercourses, eight which find their life requisites only along wooded watercourses.

The species' requirements for snags and den trees in wooded watercourses did not vary greatly between wooded watercourses not within 200 feet of permanent water (lowland hardwoods) and wooded watercourses within 200 feet of permanent water (riparian). Riparian and flood plain hardwoods were separated from lowland hardwood primarily to facilitate multi-resource management. There was no evidence of a preference for snags over den trees, so requirements are given as den trees. These requirements are shown below:

<u>DBH Class</u>	<u>Optimum Den Trees/Ac.</u>	<u>Minimum Recommended Dens/Ac.</u>
Greater than 19"	2+	1
10" - 19"	14+	7
Less than 10"	9+	4

<sup>7</sup>Species information is available from the author at Box 509, Rolla, MO 65401.



Snags in the riparian and flood plain hardwoods zones should be managed by natural mortality only. Because of the physiological characteristics of the tree species occurring there (softer wood and shorter life expectancy than upland hardwoods), snag requirements should not be a limiting factor.

#### DETERMINING OBJECTIVES

The biological requirements presented above provide the basis for establishing agency or landowner objectives. Other multi-resource objectives may require objectives below the optimum. Objectives can be established by:

1. Determining the appropriate set of guides from the land use pattern key.
2. The silvicultural system used.
3. The role of old growth.
4. The specific objectives in relationship to optimum.

#### Land Use Patterns

To determine appropriate species and biological standards it was necessary to define major land use patterns in Missouri. The committee identified three major patterns (forest interior, semi-open and open) based on habitat preferences of the species. Three additional combinations (forest inclusion in semi-open and open, and semi-open inclusion in forest interior) were also identified. Descriptions of these land use patterns are:

Forest Interior: Greater than 70% of a 5,000 acre evaluation area in contiguous forest cover. (fig.1)

Semi-open: 70-20% forested of a 5,000 acre evaluation area (fig. 2).

Open: Less than 20% forested. (fig.2).

Forest Interior Inclusion in Semi-open or Open Land Use Pattern: A block of contiguous forest cover qualifies to be managed for forest interior species in a semi-open or open land use pattern if it is at least 1,000 acres managed by an even-age system or 500 acres managed by an uneven-age system. (fig.2)

Semi-open Inclusion in Forest Interior Land Use Pattern: When 20% of relatively contiguous semi-openland exists in a forest interior land use pattern. (fig.1)

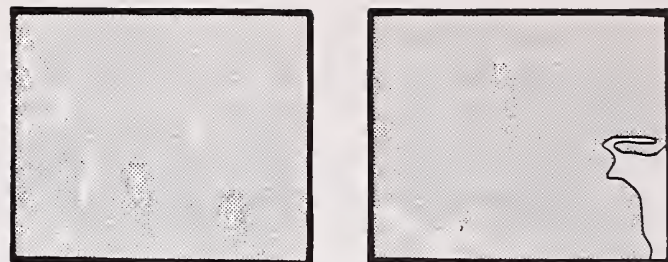

FIGURE 1.--Figure illustrates the forest interior land use pattern and an example of forest interior with a semi-open inclusion. Each illustration represents a 5,000 acre land area. Shaded areas are forest cover.

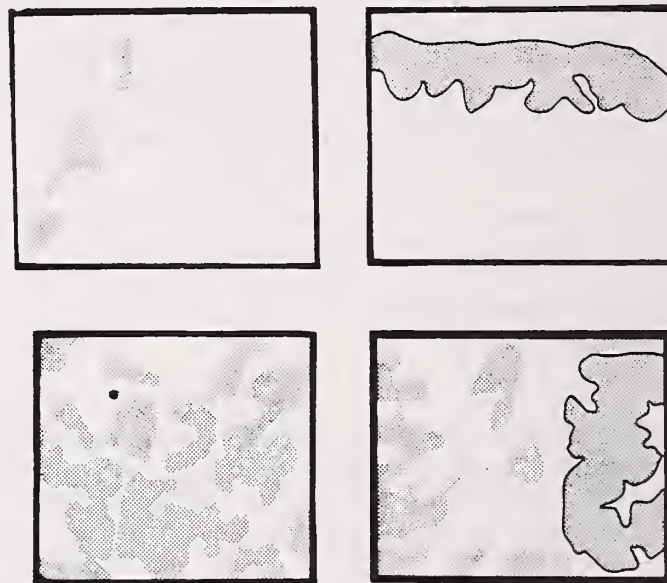

Figure 2.--Figure illustrates open land use pattern (top) and semi-open land use pattern (bottom) with examples of a forest interior inclusion. Each illustration represents a 5,000 acre land area. Shaded areas are forest cover.

Later in the process the committee decided that recommendations for semi-open and open land use patterns were so similar that they should be combined.

These land use patterns further help the land manager decide what species and guides should be emphasized by the use of a dichotomous key. This key was designed using the land use patterns and their combinations as well as the wooded watercourses which may occur within any land use pattern. This key should standardize the interpretation of snag and den tree objectives as they are applied.



KEY TO GUIDES BY LAND USE PATTERNS

- A. Forest Interior (Greater than 70% forested) . . . . . B
- A. Semi-open (20 to 70% forested) and open lands (less than 20% forested) . . . . . F
- A. Wooded Water Courses . . . . . I
  - B. Forest Interior with little or no semi-open and open lands) . . . . . C
  - B. Forest Interior with Semi-open and Open Lands clumped (500 ac. of semi-open and open in 25% of 5,000 ac.) . . . . . D
  - B. Forest Interior with Semi-open Stands . . . . . E
  - C. Apply Forest Interior Objectives . . . . . -
  - D. Apply Forest Interior Objectives to Forest Portion and Semi-open/Open Objectives to Semi-open/Open Portions . . . . . -
  - E. Apply Semi-open Land Objectives by Stands . . . . . -
  - F. Forested Portion Dispersed . . . . . G
  - F. Forested Portion Clumped . . . . . H
  - G. Apply Semi-open Land Objectives . . . . . -
  - H. 1,000 Ac. Forest Under EAM or 500 Ac. Under UAM or No Management. Apply Forest Interior Objective to the Forested Portion . . . . . -
  - I. Wooded Water Course not Within 200 feet of Permanent Water. Apply Lowland Hardwood Objectives . . . . . -
  - J. Wooded Water Course Within 200 feet of Permanent Water. Apply Riparian Objectives . . . . . K

Silviculture Systems

Major silviculture systems implemented in the United States are clear-cutting, seed-tree, shelterwood, single-tree selection, and group selection. Clear-cutting, seed-tree, and shelterwood systems generate stands of trees of the same age. This system is called even-age management (EAM). Single-tree selection and group selection produce and maintain stands of trees of several age groups. This system is called uneven-aged management (UAM) (Society of American Foresters with Cooperation of the Wildlife Society 1981). Both the even-age and uneven-age systems are used in Missouri, the size of ownership and landowner objectives will determine which system is most suitable. The system selected will influence the techniques and practices necessary to meet den tree and snag objectives (the number and size/acre).

Old Growth

Past land management on Missouri's public lands has attempted to accommodate the needs of

species requiring snags and den trees by designating 8-12% of each management unit as old growth or potential old growth. This paper illustrates that adequate numbers of dens and snags cannot be provided from a limited amount of old growth. Although the number of snags and dens within these stands are, or will be high, their existence is clumped on the landscape causing very dispersed distribution. Advantages of using old growth management are that these stands can be identified, designated, and protected from harvest, while the rest of a management unit may then be treated with little or no regard for snags and den tree management.

The amount and quality of old growth can make an important contribution to meeting den tree and snag objectives. However, the emphasis on old growth varies among landowners and agencies and old growth alone may not meet den tree and snag requirements.

MANAGEMENT TECHNIQUES

Management for snag and den tree objectives should be met over large (approximately 1,000 acres) areas. Opportunities to reach these objectives will vary greatly according to the characteristics of stands involved. Site potential, topography and especially dominant size class of the stands in the evaluation area will influence the manager's capability to achieve objectives. Administrative objectives will also influence the intensity of den tree and snag management. Because these variables exist we have suggested a variety of techniques and recommendations to assist managers with their objectives.

Achieving den tree objectives under present stand conditions in Missouri may be difficult. Limited inventories on lands managed by the Missouri Department of Conservation and the U.S.D.A. Forest Service show den tree densities presently range from one to eight per acre, usually three to five per acre. These are generally in the 10-19 inch DBH size class, the large den trees (greater than 19 inches dbh) are scarce. If the manager was to set top priority on cavity users, the optimum system would be not to cut any trees, but designate the tract as old growth for perpetuity. However, this is the exception rather than the rule as land managers attempt to manage under the multiple-use concept.

Even-age Management

There are three prescriptions common to even-age management, 1) clear-cut, 2) intermediate thinning; and 3) leave. To achieve den tree objectives for a tract of land the manager will need to meet objectives on a per acre average by stand. If the stand prescription is to leave or be designated as old growth then little concern should be given to the preservation of the den tree component. When treatments are prescribed, methods will vary with the type of treatment and stand age.



## Clear-cut Prescription (Regeneration)

When a stand is clear-cut its contribution to den tree and snags will be negligible for at least 50 years unless trees are designated to remain. In the regeneration stands two techniques may be applied either singly or in combination; individual den trees may be left or the clump technique may be used. Either technique or combination may be utilized, but seldom can optimum objectives be achieved through time, primarily because there is limited knowledge of den tree survival or how many need to be left to meet objectives after natural mortality.

The manager should consider the clump technique when the aspect of a stand will expose leave trees to high winds. Generally, protected drainages, coves, and north and east slopes should be the best locations for both individual trees or clumps. Strive to leave trees with long life expectancies when the choice is available i.e., the white oak group should be selected over the black oak group.

Individual Tree Selection: Snag and den tree objectives can be met by selecting individual trees to reserve as den trees or to be deadened as snags. This technique can be utilized in all silvicultural management systems, but does have associated disadvantages as well as some definite advantages. Biological disadvantages associated with trees selected to remain in clear-cuts are:

1. Individual den trees grown in a forest stand have relatively small root systems which do not anchor the tree well enough when left in a new opening with associated high winds. These trees are vulnerable to windthrow.
2. Added stress of winds and lightning may cause breakage of tops and boles.
3. The drastic change of micro-climates can cause top dieback and tree mortality.

Some management disadvantages also present themselves:

1. Accounting for individual trees to ensure that objectives are being met poses some administrative difficulties, especially when several crews are marking reserve trees.
2. Protecting these reserve trees during post sale activities presents a problem i.e., cordwood and firewood operations, natural regeneration work and precommercial and commercial treatments of young stands.

Advantages of the single tree selection tend to be for the animal species rather than administrative. These advantages are:

1. An actual count can be made (either in regenerated stands or intermediate treat-

ments) which helps the manager know when his snag and den tree objectives are being met.

2. An even distribution of snags and den trees can be achieved because an attempt is being made to leave them as they occur on the landscape<sup>8</sup>. This may reduce intra- and inter-species competition for dens. (Bull et al. 1980)

When the individual tree selection method is used, select species with long life expectancies. These trees should be selected in protected locations when possible i.e., side slopes and drainages. When regenerations are located on the more exposed sites of the landscape, the manager may want to utilize the clump method of leaving reserve den trees.

The Clump Method: To ensure that den trees and large diameter snags are available in stands 10-50 years after a regeneration cut will require a different management technique. The manager can choose one or more large existing dens and reserve a portion of the stand surrounding them to protect them during the post clear cut stage. Some shortcomings are associated with this technique if used unilaterally to meet den tree objectives. The distribution of dens is not even on the landscape and meeting den tree objectives is difficult because den trees plus shelter trees take up a large amount of the area.

The committee elected to count shelter trees as potential den trees and snags. Advantages associated with this method are:

1. It would reduce or eliminate many of the stresses associated with isolated trees, providing for longer wildlife utilization.
2. Clumps can be excluded during sale layout and kept intact and trackable through successive treatments.
3. Trees left as protection for dens would provide a source of potential large dens and snags in young (10-50 year old) stands.

Based on stocking charts by Ashley (1980), the optimum<sup>7</sup> live dens by recommended size classes, occupies 7% of each acre; however, it is more desirable to leave a clump large enough to be distinguishable during management activities and yet provide distribution on the landscape. The following selection and spacing criteria are based on ranges of pertinent wildlife species. For each five acres of opening the specified clump size is needed to meet den requirements. The clump should contain one or more larger (greater than 10 inches) dens per 1/3 acre of clump. As management intensity is decreased

<sup>8</sup>Den tree spacing guides are available from the author at Box 509, Rolla, MO 65401.



from optimum we recommend that the clump sizes be decreased, but the manager continue to maintain a clump per 5 acres of regeneration.

<u>Den Management Level</u>	<u>Clump Size in Acres per 5 Acres of Regeneration</u>
90-100%	1/3
70-90%	1/4
50-70%	1/5

The following criteria should be followed when selecting the location of clumps in clear-cut stands. They are ranked by priority.

1. Select trees with largest diameters that have obvious active dens and reserve 3-5 (dominant or codominant) trees around them, regardless of topography or proximity to stand boundaries.
2. Select areas to be reserved, such as finger draws that protrude into regeneration patches and sink hole inclusions. Reserve all den trees and surrounding trees within the draw or sink hole.
3. Select den trees and clumps of reserve trees near the lower end of the slope or just below the top of the ridge. Avoid reserving individual trees on mid-slopes or ridge tops.
4. In ridge top stands, reserve clumps of trees surrounding den trees near the edges of the stand.
5. If clumps are reserved in the center of regeneration patches, also reserve trees leading from the edge of the stand to the reserve clump or from a reserved clump in a draw to the center reserve clump.
6. Species of den trees selected are critical. If more than enough dens exist to meet management objectives, then choose species with long life expectancies and which achieve large diameters<sup>9</sup>.

Management of clumps should be limited to designation of clump areas and protection from other activities. No harvest or TSI should take place within the clumps, minimizing damage to existing dens and ensuring that a range of size classes required by wildlife is provided.

#### Thinning Prescriptions

In stands where intermediate treatments are to be implemented there is no need to manage clumps. The harsh change in environment does not occur and early mortality should not be a problem. The number of den trees reserved depends upon the management goal. Spacing guides

<sup>9</sup>Species selection guidelines are available from the author at Box 509, Rolla, MO 65401.

are available to help the manager achieve objectives<sup>10</sup>. Some other guidelines are as follows:

1. Where young stands less than 50 years of age have been regenerated and the clump method was used, the original clump should be distinguishable and protected as a source of cavity sites.
2. When choosing individual den trees in a stand, it is desirable to have them as evenly spaced as possible.
3. When objectives for den trees greater than 19" dbh cannot be met, select a 10"-19" tree as a replacement. When 10"-19" objectives are not attainable, leave trees as potential den trees which show signs of stress, over maturity or subject to rot. Little is known about which trees will make good den trees, but much depends on individual vigor and previous stresses listed by Conner (1978); Fungal conks, fruiting bodies of species known to cause heart rots (Shigo and Larson 1969, Hepting 1971, Miller 1972, Conner et al. 1976), dead branch stubs (Baumgartner 1939, Shigo and Larson 1969, Conner et al. 1976), old wounds caused mechanically, by lightning or fire (Hepting 1935, Hepting and Hedcock 1937, Stickel 1940, Toole 1959, Shigo and Larson 1969). Also listed are discolored or soft decayed wood in increment corings (Toole 1959, Shigo and Larson 1969, Conner et al. 1976, Jackson 1977). Other possible clues like woodpecker holes or cavities and dead portions of trees may be indicators.

#### Uneven-aged Management

The Uneven-age Management System will be used most often on 1) units less than 1000 acres of private ownership, 2) lowland hardwood tracts, and 3) public owned upland hardwood tracts where the visual impact of regeneration is undesirable.

Upland Hardwoods:--When the UAM System is implemented, snag and den tree objectives can be met by selecting individual den trees in each stand. Snag objectives should be easily met during TSI operations. When the number of existing den trees is below the manager's objectives, potential den trees may be selected using the recommendations listed above.

#### Wooded Water Courses

The lowland hardwoods of Missouri are primarily along big river drainages while the riparian habitat may exist along all streams.

<sup>10</sup>Den tree spacing guides are available from the author at Box 509, Rolla, MO 65401.



Although most lowlands have been cleared of forest to produce agricultural crops, some lowland hardwoods remain and are managed for waterfowl mast and/or forest products. Management for other resources could soon eliminate existing and potential den trees favoring the younger fast growing individuals, i.e., pin oak, which bear highest yields of mast during the ages of 25-80 years (Fowells 1965).

Lowland Hardwoods--(Wooded, Not Within 200 feet of Permanent Water) A high density of den trees is necessary to meet the requirements of cavity users in the lowland hardwoods. Two methods can be utilized to meet these objectives:

Stands may be designated as old growth, and/or individual den trees may be marked. It is generally accepted that oak species are one of the most desirable as a dominant species in the lowland hardwoods, both for wildlife mast and forest products. Designating old growth stands may result in the eventual loss of oaks to more shade tolerant species; therefore, this may be an undesirable method to use. To prevent the conversion to shade tolerant species it has generally been accepted that an uneven-age management system will remove individual trees from stands, but maintain a dominance of oak species (Putnam et al. 1960). Marking individual den trees should be compatible with this management system. Leaving the 25 trees per acre of the recommended size classes occupies 30% of each acre. Maintaining densities lower than 50% of those recommended may have a compromising effect on respective cavity users.

Snag management in the lowland hardwoods depends on the existing density of den trees and the level of their management. If managers choose to supplement den trees with snags they should follow these guidelines.

1. Attempt to achieve an even distribution of snags.
2. Attempt to leave snags which are relatively rot resistant.
3. When excessive den trees exist they make excellent snags.

Riparian--(Wooded, Within 200 feet of Permanent Water). The objectives for riparian habitats are the same as for lowland hardwoods; however, the habitat should be managed to maximize opportunities to host species requiring cavities. There should be very little closely managed timber cutting in the 100-200 foot zone along stream banks.

If individual trees are managed or removed because they are of high economic value, their removal should not compromise the integrity of the habitat or the quality of the stream. This habitat would lend itself to old growth classification.

## ACKNOWLEDGEMENTS

Contributing committee members were from the Mark Twain National Forest: Jim Keniston, Supervisory Forester; Doyle Henken, Silviculturist; Earl Simpson, Forestry Technician; Ross Melick, Zone Geneticist; Cathy Neelan, Wildlife Biologist; Roger Kirkman, Wildlife Staff Specialist; Gary Houf, District Ranger, and from the Missouri Department of Conservation: Rick Clawson, Wildlife Research Biologist; Jim D. Wilson, Ornithologist; John Meyer, Wildlife Land Management Biologist; Tom Johnson, Herpetologist; Gene Kelly, Wildlife Land Management Biologist; Jim Henry Wilson, Endangered Species Coordinator; Dave Ericson, Wildlife Research Biologist; and Norb Giessman, Wildlife Research Biologist.

## LITERATURE CITED

- Ashley, Burl S. 1980. Reference handbook for foresters, U.S.D.A. For. Serv., State and Private For. Northeast Area. NA-FR-15. 35 p.
- Baumgartner, L. L. 1939. Fox squirrel dens. *J. Mammal.* 20(4): 454-465.
- Brawn, J. D. 1979. The relationship of cavity nesting birds to snags in the oak-hickory forest. Unpublished M.S. Thesis, University of Missouri, Columbia. 150 p.
- Bull, Evelyn L., Asa D. Twombly, and Thomas M. Quigley. 1980. Perpetuating snags in managed mixed conifer forests of the Blue Mountains, Oregon. (In) Management of western forests and grasslands for nongame birds Workshop Proc. U.S.D.A. For. Serv., Gen. Tech. Rep. INT-86, p. 325-336.
- Conner, Richard N., and Curtis S. Adkisson. 1974. Eastern bluebirds nesting in clear-cuts. *J. Wildl. Manage.* 38(4): 934-935.
- Conner, R. N., O. K. Miller, Jr., and C. S. Adkisson. 1976. Woodpecker dependence on trees infected by fungal heart rots. *Wilson Bull.* 88(4): 575-581.
- Conner, Richard N. 1978. Snag management of southern forests for nongame birds. U.S.D.A. For. Serv. Gen. Tech. Rep. SE-14. p. 120-128.
- DeGraff, Richard M. 1978. New life from dead trees. *Natl. Wild.* 16(4): 29-31.
- DeGraff, R. M., G. M. Witman, J. W. Lanier, B. J. Hill, and J. M. Keniston. 1980. Forest habitats for birds of the Northeast. U.S.D.A. For. Serv., Washington D. C. 598 p.
- Evans, Keith E., and Richard N. Conner. 1979. Snag management. U.S.D.A. For. Serv., Gen. Tech. Rep. NC-51, p. 214-225.

- Fowells, H. A. 1965. Silvics of forest trees of the United States. U. S. Dept. Agric., Handb. 271, 762 p.
- Hardin, Kimberly I., and Keith E. Evans. 1977. Cavity nesting bird habitat in the oak-hickory forest . . . a review. U.S.D.A. For. Serv., Gen. Tech. Rep. NC-30, 23 p.
- Hepting, G. H. 1935. Decay following fire in young Mississippi Delta hardwoods. U.S.D.A. Tech. Bull. 494.
- Hepting, G. H. 1971. Diseases of forest and shade trees of the United States. U. S. Dep. Agric. For. Serv. Agric. Handbook 386. 658 pp. U. S. Govt. Printing Office Washington, D. C.
- Hepting, G. H. and G. C. Hedgcock 1937. Decay in merchantable oaks, yellow poplar, and basswood in the Appalachian region. U. S. Dep. Agric. Tech. Bull. 570.
- Jackson, J. A. 1977. Red-cockaded woodpeckers and pine red heart disease. Auk 94(1); 160-163.
- Johnson, Tom R. 1977. The amphibians of Missouri. Univ. of Kansas Museum of Natl. Hist. Public Education Series No. 6 134 p. Univ. of Kansas Publications
- Miller, O. K. Jr. 1972. Mushrooms of North America. E. P. Dutton & Co., Inc. New York. 360 pp.
- McComb, William C. 1982. Forestry and wildlife habitat management in central hardwoods. J. For. 80(8):490-492.
- Putnam, John A., G. M. Furnival, and J. S. McKnight. 1960. Management and inventory of southern hardwoods. U.S.D.A. For. Serv., Agric. Handb. 181, 102 p.
- Schroeder, Walter A. 1981. Presettlement Prairie of Missouri. Natl. History Series No. 2. Mo. Dept. Conservation. 37 p.
- Schwartz, Charles W., and Elizabeth R. Schwartz. 1959. The Wild Mammals of Missouri. 341 p. Univ. of Missouri Press and Mo. Conserv. Commission.
- Shigo, A. L., and E. H. Larson. 1969. A photo guide to the patterns of discolorations and decay in living northern hardwood trees. U.S.D.A. For. Serv. Res. Pap. NE-127, 100 pp.
- Society of American Foresters with Cooperation of the Wildlife Society. 1981. Choices in silviculture for American forest society of American foresters. 80 p.
- Steyermark, J. A., Flora of Missouri. 1725 p. The Iowa State University Press.
- Stickel, P. W. 1940. The basal wounding of trees by fire. The effect of basal wounding by fire on trees in the northeast. U.S.D.A. For. Serv. Tech. Note 30. Northeast. For. Exp. Stn.
- Thom, Richard H., and James H. Wilson. 1980. The natural divisions of Missouri. Trans. of Mo. Acad. of Sci. 14(1): 9-23.
- Toole, E. R. 1959. Butt rot of southern hardwoods. U.S.D.A. For. Serv., For. Pest Leaflet 43, 4 pp. Southern For. Exp. Stn.



# Snag Management: Options and Incentives for Private Landowners<sup>1</sup>

Lorin L. Hicks <sup>2/</sup>

---

Abstract.--Existing and needed incentives for snag management on private lands are discussed. Realistic management objectives must identify areas where habitat can be continuously supplied for minimum viable populations using cost effective methods. The economic and biological feasibility of some options are discussed. Until further incentives are developed, reasonable options include snag retention in riparian zones and limited-use areas, recognition of priority tree species and road management to reduce snag loss to firewood cutters.

---

## INTRODUCTION

A wide variety of forest wildlife requires snag habitat for their existence. Approximately nine percent of all wildlife species in the U.S. Forest Service Northern Region are dependent on dead or dying timber of all size or age classes, including 25 percent of the bird species breeding in Rocky Mountain Forests (Harger 1978, McClelland et al. 1979).

Many questions have been raised regarding the role of private lands in the management of snag-dependent habitat. Some segments of the public feel that high intensity, short-rotation timber management commonly practiced on industrial forestlands is inconsistent with snag management practices for wildlife. Landowners want to know what population levels are required, why private lands are needed to support snag-dependent wildlife, and what costs must be incurred to provide this habitat.

The purposes of this paper are to identify existing and needed incentives for maintaining snag-dependent wildlife on private lands, establish realistic management objectives, evaluate the costs of two management approaches, and recommend snag management options which are compatible with intensive management of industrial forestlands.

## INCENTIVES FOR MAINTAINING SNAG-DEPENDENT WILDLIFE

Although there are many options available, few

incentives encourage snag management on private land.

Avian control of deleterious insect pests is commonly promoted as a reason to support insectivorous cavity-nesting birds. However, this argument is unrealistic when compared to the cost of providing the required habitat and the effectiveness of other control methods such as forest chemicals. Birds exert some control on insect populations at endemic levels, but are ineffective in reducing insects at epidemic levels when significant damage occurs to standing forest crops (Bruns 1960, Beebe 1974).

The primary incentive for maintaining snag-dependent wildlife habitat on industrial forestlands stems from a recognition of public concerns and corporate responsibilities.

One way in which public concern is expressed is through the pursuit of wildlife-oriented recreation. A national survey by the U.S. Fish and Wildlife Service in 1980 revealed that 83 million Americans, or 49 percent of all adults 16 years of age or older, engaged in recreational activities directed at the nonconsumptive appreciation of wildlife (Lyons 1982). The extent of participation in these activities reflects not only a substantial demand for the products of wildlife management, but also an increasing interest by the public as to where these products will be produced and who should provide them.

Corporations are owned by stockholders who desire a reasonable return on their investment. Stockholders also expect their companies to operate in a responsible and ethical manner. Consequently, consideration of social and environmental concerns must be recognized as a cost of doing business. Although providing for the needs of snag-dependent wildlife may require extra attention by the private landowner, ignoring the needs of these species invites conflict and restrictive regulation.

---

<sup>1/</sup>Paper presented at the Snag Management Symposium. [Northern Arizona University, Flagstaff, Ariz., June 7-9, 1983].

<sup>2/</sup>Lorin L. Hicks, Wildlife Biologist, BN Timberlands Inc., Missoula, MT.



There is no direct economic benefit which flows to industrial forest landowners as a result of any level of snag management. Perhaps the most effective incentive has yet to come in the form of tax reductions and other methods which allow the landowner to defray the direct costs of providing this habitat in the public interest. However, for legislation of this nature to be passed, the general public as well as the private landowner will have to be convinced that public lands, wilderness areas, and parks do not provide enough habitat to support desired population levels of snag-dependent wildlife.

In the Rocky Mountains, 75 percent (43.2 million acres) of the commercial timberland is in public ownership with industry controlling only 4 percent (2.1 million acres) of the total (Beuter 1980). Private lands are often intermingled with public land in a checkerboard ownership pattern. A definite need for this habitat on private lands must be established in order to determine priorities and mechanisms to offset management costs.

#### OBJECTIVES FOR SNAG MANAGEMENT

To be effective on intensively managed forests, snag management must have clearly defined objectives. A realistic snag management plan must recognize four points.

First, intensively managed industrial forestlands should not be expected to support more than minimum viable populations of snag-dependent wildlife species. Second, management approaches which do not address all existing wildlife species or uses are not wise investments. Third, snag retention methods must be employed which minimize direct costs or value reductions to the landowner. Fourth, areas must be selected on private lands where the natural processes which perpetuate snags can be preserved as well as the snags themselves.

#### SNAG MANAGEMENT OPTIONS

In order to discuss the feasibility of snag management options on private lands, a realistic assessment of anticipated costs must be developed. Two management options have been widely discussed. The first approach, which has been employed on public lands, involves the retention of merchantable trees to serve as a continual supply of snags on a "per-acre" basis throughout a stand rotation (Thomas 1979). The second approach, which has been recommended for private lands, uses bird boxes to replace snags and merchantable timber removed during harvest (Bruns 1960, Brawn and Balda 1981).

#### Snag Retention

In his publication, "Wildlife Habitats in Managed Forests," Thomas (1979) developed an example

to illustrate the impacts of snag retention on wood production in the Blue Mountains of Oregon and Washington. Using this familiar example, I calculated the present-day value of income foregone by employing this technique on 100 acres of commercial timberland (table 1). The basic assumptions are that suitable snags will be continuously supplied to support populations of cavity-excavating species at 60 percent of maximum potential in a ponderosa pine stand managed on a 150-year rotation with a shelterwood silvicultural system.

Table 1. Present-day value of volume forgone on 100 acres to provide snag habitat at the 60 percent level in a ponderosa pine stand managed on a 150-year rotation.

Stand Age (yrs)	Silvicultural Treatment	Volume Forgone (MBF) 1/	PDV Forgone (\$) 2/
0 or 150	Overstory Cut	143.4	11,472.00
80	Thinning	22.8	183.46
100	Thinning	57.0	258.29
140	Shelter Cut	4.2	6.04
Total		227.4	11,919.79

1-Data on volume foregone from Thomas (1979). Conversion rate used was 6 BF = one cubic foot.

2-Stumpage value (average) = \$80.00/MBF, 3% real increase on stumpage value, 6% discount rate.

Total wood volume sacrificed over 150 years to meet these objectives on 100 acres amounts to 228,400 board feet at a present-day value of \$11,919.79, or \$119.20 per acre. To put these figures into perspective, forestland of this type currently sells for \$300-\$400 per acre. Planting costs in this timber type average \$100 per acre. Implementation of this alternative would cost nearly a third of the current market value of the land and exceed the costs of putting a similar site back into wood production.

#### Bird Boxes

To evaluate a bird box program applied to the same 100 acres, breeding territory sizes were obtained from the literature for secondary cavity-using mammals (Chapman and Feldhamer 1982) and birds (Franzreb 1977). These data indicated that 130 boxes would be required to provide for 60 percent of optimum populations. As shown in Table 2, the total present-day cost of maintaining this program on 100 acres for 150 years amounts to \$6,786.00, or \$67.86 per acre.



Table 2. Cost summary for a bird box program to maintain secondary cavity-using species at 60 percent level for 150 years on 100 acres in ponderosa pine timber type. All units are in dollars.

<u>Expense Item</u>	<u>Per Box 1/</u>	<u>Total Program (130 Boxes)</u>	<u>Present Day Cost 2/</u>
Initial:		\$1,785	\$1,785
Construction	\$11.49		
Installation	\$2.24		
Annual (150 yrs)		\$319	\$5,001
Replacement 1/	\$13.73		
Maintenance	\$1.40		
Total Present-Day Cost:			\$6,786

1-Cost data are from a 3-year bird box feasibility study on public land near Missoula, MT (Rob Hazlewood, Wildlife Biologist, Bureau of Land Management, Missoula, MT, pers. comm.). Annual box loss rate on this study averaged 8% per year.

2-A 6% discount rate was used for present-day cost calculations.

In addition to being expensive, the bird box alternative has a number of biological shortcomings. Most important is the fact that bird boxes alone will not support the major woodpecker species which must excavate holes as part of their courtship behavior. In addition, bird boxes are attractions for predators and parasites (Tardell and Doerr 1982, Pinkowski 1977) and may increase mortality of resident species during winter months. Finally, bird boxes will not provide for the other wildlife uses of snags such as roosting, feeding, and perching sites.

There are actually two different "costs" involved with these options. In the snag retention option, costs represent present-day wood fiber value foregone to meet long-term objectives. With bird boxes, an immediate out-of-pocket expense is required for initial construction and installation, as well as a financial commitment to maintain and replace the boxes over time.

It should be recognized that the anticipated costs for both options would probably be reduced if applied to ownerships larger than 100-acre units. However, these figures indicate that widespread provision for snag-dependent wildlife habitat on a sustained "per-acre" basis represents a substantial and prohibitive cost for an industrial forest landowner.

#### Logging Residue as Snag Habitat

Logging residue, natural mortality, and the retention of existing snags and cull trees in cutting units can support a variety of snag-

dependent wildlife in a managed forest (Franzreb 1977, Webb 1977, Titterington 1979). However, operations such as broadcast burning and aerial application of fertilizers or herbicides can be complicated by leaving large standing snags within cutting units. This problem may be partially avoided by retaining snags and cull trees on the edge of cutting units. This option has value, but should be recognized as a short-term solution to the problem of providing suitable habitat over time, since no provision is made for replacement snags.

#### RECOMMENDATIONS

Based on the previous discussion of objectives and feasibility of management options, the following recommendations are offered to integrate snag management into intensive forest management on industrial lands:

1) Utilize riparian zones, inoperable sites, visual zones, and other "limited use" areas for snag management. This reduces direct cost and conflict with other land use objectives, while preserving a continual supply of snags in various size and age classes.

2) Although all tree species are used to some extent by snag-dependent wildlife, attention should be given to retain tree species most preferred by wildlife in the area. For instance, in northwestern Montana the most valuable tree species for wildlife are (in descending order): western larch (Larix occidentalis), ponderosa pine (Pinus ponderosa), cottonwood/aspen (Populus spp.), and paper birch (Betula papyrifera), (McClelland et al. 1979).

3) Road management has become one of the most important tools for snag management. Due to heavy woodcutting pressure in Montana, we have been forced to "write off" snags within 200 feet of an open road. Loss to firewood cutters is a strong argument against leaving snags for wildlife in flat, accessible areas. The problem is widespread, as indicated by Scott et al. (1980) in Colorado, where 97 out of 100 signed "wildlife trees" were removed by woodcutters within two years. Increased road management and public education will be necessary if snag management programs are to be successful on both public and private lands.

#### SUMMARY

Recognition of social concerns and corporate responsibility are the only existing incentives to provide habitat for snag-dependent wildlife on industrial forestlands. With the abundance of public land present in the west, a clearly defined need for this habitat on private lands must be established. Some options which have been proposed or employed on public lands are not economically feasible for the private landowner. Realistic snag management objectives must be developed which identify areas where a continual supply of habitat



components can be provided for minimum viable populations of all existing species using the most cost-effective methods. Programs to provide habitat for snag-dependent wildlife on industrial forestlands must be balanced with the need to meet economic objectives.

Until more tangible incentives are developed,

the retention of snags in limited use and special management areas, recognition of priority tree species to retain for wildlife, and road management to reduce loss of snags to firewood cutters are the most feasible options for snag management on intensively managed private forestlands.

#### LITERATURE CITED

- Beebe, Spencer B. 1974. Relationships between insectivorous hole-nesting birds and forest management. Yale University Sch. For. Env. Studies., New Haven, Conn. 49 p.
- Beuter, John H. 1980. Timber in the United States: a strategic resource for the twenty-first century. Working paper for the National Conference on Renewable Natural Resources. [Washington, D.C., Nov. 30-Dec 3 1980] American Forestry Assn., Washington, D.C. 39 p.
- Brawn, Jeffrey and Russell Balda. 1981. Progress report of nest-box study. Federal Timber Purchasers Assn. and National Forest Products Assn., Washington, D.C. 14 p.
- Bruns, Herbert. 1960. The economic importance of birds in forests. *Bird Study* 7(4):193-208.
- Chapman, Joseph A. and George A. Feldhamer. 1982. Wild mammals of North America: biology, management, and economics. 1,147p. The Johns Hopkins Univ. Press, Baltimore, Md.
- Franzreb, Kathleen E. 1977. Bird population changes after timber harvesting of a mixed conifer forest in Arizona. USDA Forest Service Research Paper RM-184, 26p. Rocky Mountain Forest and Range Experiment Station, Fort Collins, Co.
- Harger, Rosemary. 1978. Managing old-growth forests as wildlife habitat: an ecosystems approach. USDA Forest Service. Northern Region, Missoula, Mt. 50 p.
- Lyons, James R. 1982. Nonconsumptive wildlife-associated recreation in the U.S.: identifying the other constituency. *Trans. North American Natural Resources Conf.* 42:226-236.
- McClelland, B. Riley, Sidney S. Frissel, W.C. Fischer, and C.H. Halvorson. 1979. Habitat management for hole-nesting birds in forests of western larch and Douglas-fir. *Journal of Forestry* 77(8):480-483.
- Pinkowski, Benedict C. 1977. Blowfly parasitism of eastern bluebirds in natural and artificial nest sites. *Journal of Wildlife Management* 41(2):272-276.
- Scott, Virgil E., Jill A. Whelan, and Peggy L. Svoboda. 1980. Cavity-nesting birds and forest management. p.311-324. *In* Management of western forest and grasslands for nongame birds: workshop proceedings. [Salt Lake City, Utah, February 11-14, 1980] USDA Forest Service General Technical Report INT-86, 535p.
- Tardell, J.H. and P.D. Doerr. 1982. Black bear damage to bluebird nest boxes in southeastern North Carolina. *Journal of Wildlife Management* 46(2):244-245.
- Titterton, R.W., HS. Crawford, and B.N. Burgason. 1979. Songbird response to commercial clearcutting in Maine spruce-fir forests. *Journal of Wildlife Management* 43(3):602-609.
- Thomas, Jack W., technical editor. 1979. Wildlife habitats in managed forests: the Blue Mountains of Oregon and Washington. USDA Forest Service Agricultural Handbook No. 553 512 p. Washington, D.C.
- Webb, William L., Donald F. Behrend, and Boonruang Saisorn. 1977. Effect of logging on songbird populations in a northern hardwood forest. *Wildlife Monographs* No. 55, 35 p.



# Longevity of Snags and Their Use by Woodpeckers<sup>1</sup>

Evelyn L. Bull<sup>2</sup>

---

Abstract.--Fifty percent of the ponderosa pine (Pinus ponderosa) snags and 38% of the lodgepole pine (P. contorta) snags were standing 8 years after being killed by the mountain pine beetle (Dendroctonus ponderosae) in northeastern Oregon. Trees greater than 50 cm dbh stood longer than smaller trees. Woodpeckers excavated cavities in 15 of the 186 ponderosa pine snags 3 to 8 years after the trees died.

---

## INTRODUCTION

The value of snags to wildlife for nesting, feeding, and perching has been well documented (McClelland and Frissell 1975, Mannan 1977, Thomas et al. 1979, Raphael 1980). Because of their condition, size, or location, however, different types of snags have different values for cavity nesters.

In managed forests, the desired number and kinds of snags can probably be maintained only by deliberate action by resource managers. Information on the number of live and dead trees in a stand, mortality rates, and the rate at which snags fall are needed to predict snag density over time (Bull et al. 1980; Cimon, in press). The time a snag stands, however, is a function of size, rate of decay, species, and cause of death. Few studies have reported the rate at which snags fall (Keen 1929, 1955; Dahms 1949; Lyon 1977; Van Sickle and Benson 1978). My objectives were to determine: (1) how long ponderosa pine and lodgepole pine trees killed by the mountain pine beetle will stand and (2) how woodpeckers use these snags.

## METHODS

The study was conducted on the USDA Forest Service (Pacific Northwest Region) Starkey Experimental Forest 35 km southwest of La

Grande, Oregon. This area contains 11 400 ha of mixed conifer forest interspersed with grasslands at elevations of 1 070 to 1 525 m. An outbreak of mountain pine beetle during 1973-80 had killed thousands of lodgepole pine and ponderosa pine trees in the area.

From 1975 to 1977, I marked and measured dbh (diameter at breast height) of 50 lodgepole pine and 186 ponderosa pine trees. I selected trees that had been killed the previous year by bark beetles as indicated by the presence of pitch tubes and brown needles.

Each summer from 1975 to 1982, I recorded the condition of trees (standing, down, or broken) and evidence of feeding and nesting by woodpeckers for each marked tree. In addition, the following characteristics were recorded for 50 lodgepole and 50 ponderosa pines: percent of original bark and needles remaining and the amount of treetop broken off. Snags were grouped in three diameter classes: 25 cm, 25-49 cm, and  $\geq 50$  cm.

## RESULTS AND DISCUSSION

### Rate of Fall

No snags fell until the third year after death, and ponderosa and lodgepole pines in the same diameter classes fell at similar rates (figs. 1 and 2). Larger snags fell at a lower rate than smaller ones.

Rate of fall reported in the literature varies (table 1). A variety of conditions including cause of death, soil type (Keen 1955), and size affected longevity. Fire may either retard decay and allow snags to stand longer (Dahms 1949) or increase the rate of fall because no live trees remain to reduce

---

<sup>1</sup>Paper presented at the Snag Habitat Management Symposium, Flagstaff, Arizona, 7-9 June 1983.

<sup>2</sup>Evelyn L. Bull is Wildlife Biologist, USDA Forest Service, Pacific Northwest Forest and Range Experiment Station, Range and Wildlife Habitat Laboratory, La Grande, Oreg.

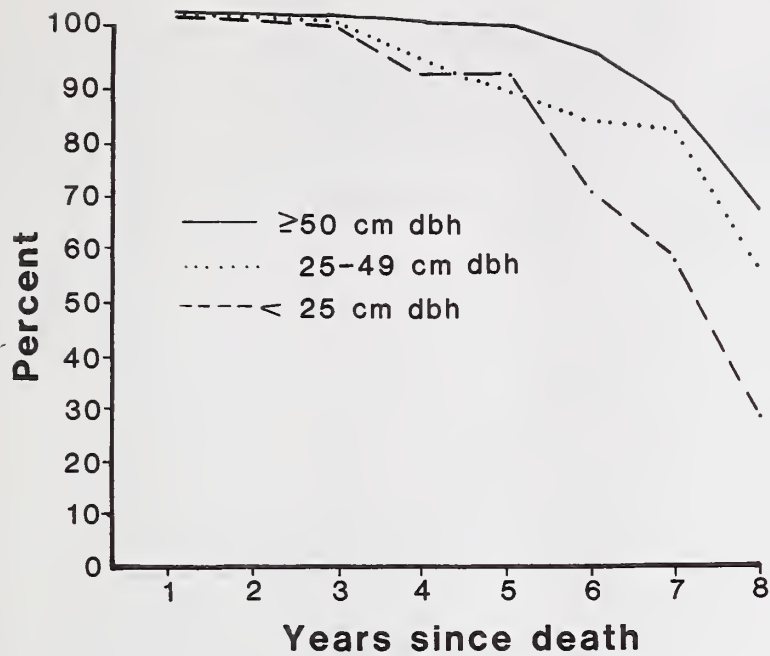

Figure 1.--Percentage of ponderosa pine snags standing, by number of years since death and diameter class, Starkey Experimental Forest, 1975-82.

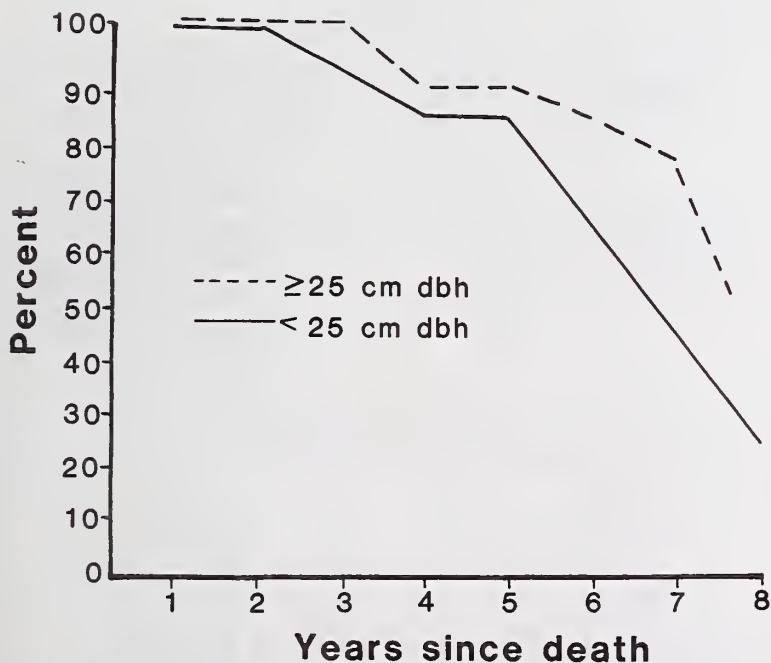

Figure 2.--Percentage of lodgepole pine snags standing, by number of years since death and diameter class, Starkey Experimental Forest, 1975-82.

wind velocities (Lyon 1977). Keen (1955) reported that soil conditions influenced the rate of fall more than did cause of death.

Keen (1929, 1955) and Dahms (1949) agree that large snags fall at a lower rate than

small snags. Because sapwood is more susceptible to decay than heartwood, trees with a thicker core (larger diameter) of heartwood decay slower and stand longer.

#### Woodpecker Use

There was evidence of feeding by woodpeckers on 82% of the ponderosa pine snags and 92% of the lodgepole snags within the first year after the trees were attacked by bark beetles. Woodpeckers chipped the bark off (scaled) the trunks to obtain bark beetles or larvae. The bark beetle larvae generally remained in the tree 1 year before they developed into adults and moved to a new host tree.

An average of 21% of the trunk surface of the lodgepole pine and 3% of the ponderosa pine was scaled. The lesser amount of activity on the ponderosa pines was probably due to lower insect densities or reduced accessibility because of thicker bark. The scaling occurred on the lower or middle third of the tree trunk on 83% of the trees used by the woodpeckers.

Size of tree, time since death, and broken tops were important in the selection of nest trees. Woodpeckers excavated cavities in 15 of the 186 ponderosa pine snags within the 8 years (table 2). No cavities were found in lodgepole pines or ponderosa pines less than 25 cm dbh. The mean dbh of snags with cavities was 52 cm, which indicated a preference for large diameter trees.

Cavities were excavated in snags that had been dead 3-8 years. Some nest cavities were reused and new nests were excavated in some snags in successive years. Northern flickers (*Colaptes auratus*), Williamson's sapsuckers (*Sphyrapicus varius*), hairy woodpeckers (*Picoides villosus*), and white-headed woodpeckers (*P. albolarvatus*) were observed nesting.

The tops were broken out of 13 of the 15 snags used for nesting. Seventy-seven percent of the cavities occurred within 2 m of the broken top. Woodpeckers excavated here because the wood was probably decayed. Either the break occurred because the wood was already decayed or the wood began decaying when it was exposed by the break. The average cavity height was 16 m. Trees with cavities had 21% (mean) of the top broken off and retained 98% of their bark.

#### Physical Characteristics

Over the 8 years, the physical characteristics of the snags changed. The needles turned brown in 1975 but most remained on the tree. In 1976, 12% of the original needles remained; in 1977 less than 3%.



Table 1.--Comparison of snags standing reported in five studies

Snags	Keen (1929)	Dahms (1949)	Keen (1955)	Lyon (1977)	This study
	<u>Percent</u>				
Ponderosa pine:					
Standing after					
8 years	32	60	32-71		64
Standing (25-49 cm)					
after 7 years	42 <sup>1</sup>				79
Standing (>50 cm)					
after 7 years	60				86
Lodgepole pine:					
Standing after					
8 years				63	38

<sup>1</sup>Diameter class was 25-46 cm.

Table 2.--Percentage and number of ponderosa pine snags woodpecker cavities and percentage of snags with cavities that had broken tops<sup>1</sup>

Years since death	Snags 25-49 cm dbh		Snags ≥50 cm dbh		Snags with broken tops
	<u>Percent</u>	<u>Number</u>	<u>Percent</u>	<u>Number</u>	<u>Percent</u>
1	0		0		0
2	0		0		0
3	0		2	1	0
4	5	4	7	3	86
5	6	4	9	4	75
6	7	5	16	7	92
7	21	4	17	2	100
8	31	4	33	3	100

<sup>1</sup>Numbers are cumulative; a reduction means that snags fell or sample size was smaller.

Bark retention decreased from 100% to 96% on the ponderosa pines and from 100% to 89% on the lodgepole pines over the 8 years. The bark on the lodgepole was thin, dried rapidly, loosened, and fell off more readily than on the ponderosa pine. In addition, more bark was removed by woodpeckers on the lodgepole snags.

The most apparent change in the trees was broken tops (fig. 3). Few lodgepole pines but many ponderosa pines greater than 50 cm dbh had tops broken. The average amount of top broken off was 11%; the range, 5-75%.

The difference in breakage between the two tree species was probably due to physical characteristics. Because the lodgepole pine snags were small in diameter and had thin bark, the wood dried rapidly. Even though there was a high percentage of sapwood, the low moisture content retarded decay. At ground level, however, soil moisture was available, the bark was thicker and retained moisture, which probably encouraged decay. The lodgepole, therefore, were more susceptible to breakage at the base than along the stem. In contrast, the bark of the ponderosa pine snags was thicker, retained more moisture, and was therefore more susceptible to decay and breakage along the entire stem.

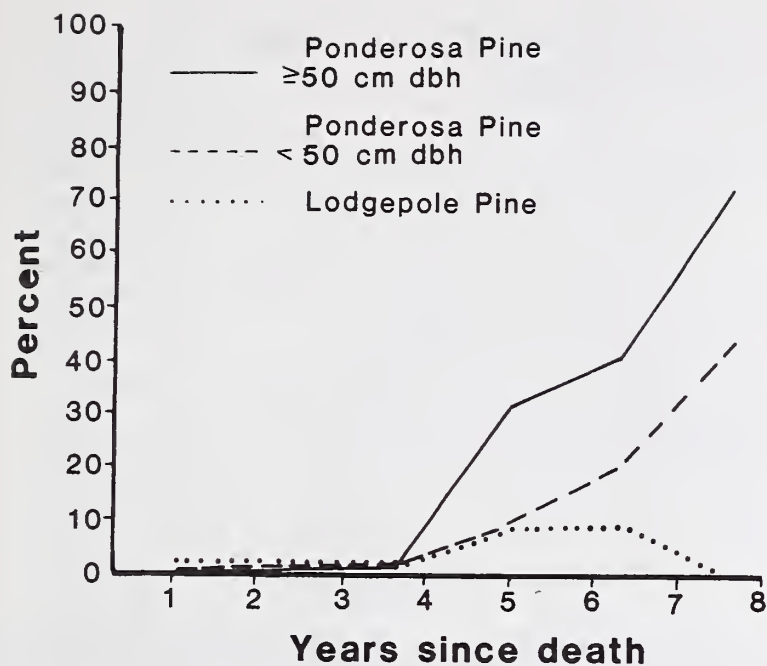

Figure 3.--Percentage of ponderosa and lodgepole pine snags with broken tops, by number of years since death and diameter class, Starkey Experimental Forest, 1975-82.

#### SUMMARY

Of trees killed by bark beetles in northeastern Oregon, ponderosa pine snags greater than 50 cm dbh stood longer than smaller ponderosa or lodgepole pines. Woodpeckers excavated cavities in larger snags that were dead at least 3 years and had broken tops. The rate of fall of different diameter classes of snags must be considered to provide number of snags over time.

#### LITERATURE CITED

Bull, Evelyn L., Asa D. Twombly, and Thomas M. Quigley. 1980. Perpetuating snags in managed mixed conifer forests of the Blue Mountains, Oregon. p. 325-336. *In* Management of western forests and grasslands for nongame birds. Workshop Proceedings. USDA Forest Service General Technical Report INT-86. Intermountain Forest and Range Experiment Station, Ogden, Utah.

Cimon, N. In press. A simple model to predict snag levels in managed forests. *In* Snag Habitat Management Symposium.

Dahms, Walter G. 1949. How long do ponderosa pine snags stand? USDA Forest Service, Pacific Northwest Forest and Range Experiment Station Research Note 57, 3 p. Portland, Oreg.

Keen, F. P. 1929. How soon do yellow pine snags fall? *Journal of Forestry* 27:735-737.

Keen, F. P. 1955. The rate of natural falling of beetle-killed ponderosa pine snags. *Journal of Forestry* 53:720-723.

Lyon, L. Jack. 1977. Attrition of lodgepole pine snags on the Sleeping Child Burn, Montana. USDA Forest Service Research Note INT-219, 4 p. Intermountain Forest and Range Experiment Station, Ogden, Utah.

Mannan, R. W. 1977. Use of snags by birds, Douglas-fir region, western Oregon. M.S. thesis. Oregon State University, Corvallis.

McClelland, B. Riley, and Sidney S. Frissell. 1975. Identifying forest snags useful for hole-nesting birds. *Journal of Forestry* 73:414-417.

Raphael, Martin G. 1980. Utilization of standing dead trees by breeding birds at Sagehen Creek, California. Ph.D. thesis. University of California, Berkeley. 195 p.

Thomas, Jack Ward, Ralph G. Anderson, Chris Maser, and Evelyn L. Bull. 1979. Snags. p. 60-77. *In* Wildlife habitats in managed forests--the Blue Mountains of Oregon and Washington. U.S. Department of Agriculture Agriculture Handbook No. 553. (Published in cooperation with the Wildlife Management Institute and the U.S. Department of the Interior Bureau of Land Management.) Washington, D.C.

Van Sickle, Charles, and Robert E. Benson. 1978. The dead timber resource--amounts and characteristics. p. 127-146. *In* Proceedings of symposium on the dead softwood timber resources. Washington State University, Pullman.



# Potential Woodpecker Nest Trees through Artificial Inoculation of Heart Rots<sup>1</sup>

Richard N. Conner, James G. Dickson,  
and J. Howard Williamson<sup>2</sup>

---

Abstract.--We suggest that the fungus *Spongipellis pachyodon* might be used to artificially create suitable hardwood nest trees for woodpeckers in both young and older trees and when supplies of potential nest trees are limited. Sizes of trees suitable for inoculation, inoculation heights, and densities of snags are suggested for six species of woodpeckers.

---

## INTRODUCTION

The use of snags by North American woodpeckers for both nesting and foraging is well documented (Balda 1975, Scott et al. 1977, Conner 1978, Evans and Conner 1979, Dickson et al. 1983). While a wide variety of sizes and conditions of snags may be suitable for woodpecker foraging sites, only certain conditions of hardwood snags are suitable for nesting. The heartwood of hardwood snags in particular must be softened by fungal decay before woodpeckers can excavate either nest or roost cavities (Conner et al. 1976). While decayed heartwood in pine (*Pinus* spp.) snags may facilitate cavity excavation, pileated (*Dryocopus pileatus*) and red-headed (*Melanerpes erythrocephalus*) woodpeckers can excavate cavities in undecayed pine snags (Conner, unpubl. data).

The increasing demands for timber products in general and firewood in particular (USDA 1982) may further decrease the availability of hardwoods that are suitable for cavity excavation. We report here a successful technique to artificially inoculate two species of heartwood decaying fungi into oaks (*Quercus* spp.). Such a technique would be valuable in forests where it is desirable to create suitably decayed hardwoods for primary cavity nesters at younger tree ages or in greater abundance than would normally occur.

---

<sup>1</sup>Paper presented at the snag habitat management symposium. [Flagstaff, Arizona, June 7-9, 1983]

<sup>2</sup>Richard N. Conner is Research Wildlife Biologist, James G. Dickson is Supervisory Research Wildlife Biologist, and J. Howard Williamson is Forestry Technician, Wildlife Habitat and Silviculture Laboratory (maintained in cooperation with School of Forestry, Stephen F. Austin State Univ.) Southern Forest Experiment Station, USDA, Forest Service, Nacogdoches, TX.

## METHODS

Local live cultures of *Spongipellis pachyodon* (Pers.) Kotl. and Pouz. and *Laetiporus sulphureus* (Bull. ex Fr.) Bond. and Sing. were obtained from decaying hardwood trees during the winter of 1979 on the Stephen F. Austin Experimental Forest, Nacogdoches Co., TX. Chips of wood were aseptically cut from pieces of the decaying hardwoods and placed on malt agar. Both cultures subsequently grown from these inoculations were identified by micro- and macroscopic characteristics and growth patterns. Identifications were verified by Frances Lombard at the Forest Products Laboratory in Madison, WI. *Spongipellis pachyodon* was selected as an inoculum because of its demonstrated association with hardwood cavity trees of woodpeckers in Virginia (Conner et al. 1976). *Laetiporus sulphureus* was selected because it was an indigenous hardwood heart rot that we had in culture.

Hollow oak dowels (5 cm long, 1.1 cm dia. with a 0.4 cm hole from end to end) were autoclaved (132°C for 40 min) in a malt extract broth solution (2.5 g malt extract per 100 ml distilled water). An oak-sawdust agar medium (15 g oak sawdust, 11 g malt agar, 2.5 g wheat bran, 1.25 g corn meal and 70 ml of distilled water per pint jar) was mixed, dispensed in pint jars and autoclaved (122°C for 50 min), and then placed on a slanted rack so the agar would harden at an angle of about 60 degrees. Pint jars were inoculated with either *Spongipellis pachyodon* or *Laetiporus sulphureus* after which four of the sterile hollow dowels were placed on top of the slanting growth medium. After 2 to 3 months' growth the hollow dowels were sufficiently infected with fungi for inoculation into oak trees. This technique modifies those used by Silverborg (1959) and Toole (1965, 1966) to inoculate hardwoods with different species of fungi.

Twenty oak trees (both *Quercus falcata* and *Q. nigra*; DBH: mean = 21.9 ± standard deviation = 5.2

cm; height: 19.7 ± 3.6 m; age: 44 ± 5.9 y) were selected in a forested area on the Stephen F. Austin Experimental Forest, Nacogdoches Co., East Texas. Oaks with obvious signs of decay or injury were automatically excluded from selection. On 11 March 1980, after sterilizing drill bits and drill locations on trees with 70% ethanol, we drilled a 1.5 cm dia. hole 13 - 15 cm deep on the north side of each tree 2 m above the ground with an electric drill. We selected the north side of the trees because it would offer the dampest micro-environment. The holes were drilled slightly upward at an angle of 10° above the horizontal to prevent the entrance of rain water and possible contamination into the holes.

Several *Spongipellis pachyodon* infected dowels were inserted into each hole and stacked tightly against each other in 10 of the drilled oaks. The last dowel inserted into each tree was left protruding from the drill hole to help prevent the tree from sealing the hole. Toole (1967) reported that success of fungal inoculations in hardwoods was much higher if the inoculation hole was kept open. We repeated the same procedure on the other 10 oak trees using *Laetiporus sulphureus* infected oak dowels. We did not attempt to inoculate old knots or limb breaks because of a high probability of being contaminated by other fungi.

Five randomly selected oaks from each group that had been inoculated with *S. pachyodon* and *L. sulphureus* were harvested 27 January 1981. The harvest procedure was repeated again on 20 January 1982. Harvested trees were horizontally and vertically sectioned to determine existence and extent of the fungal infections. Small chips of wood from areas that appeared to be infected were aseptically removed and cultured on malt agar to determine if the fungus subsequently grown was the

same species that was originally inoculated into the tree.

Use of control trees was deemed unnecessary because sections made of the experimental trees with a chain saw readily demonstrated if fungi had been introduced by our inoculation or were present prior to treatment.

## RESULTS

*Spongipellis pachyodon* was successfully inoculated into and recultured from 80% (8 of 10) of the experimental trees (table 1). While all ten of the *Spongipellis* inoculated trees visibly showed signs of heartwood decaying fungi (discolored and softened wood present in cross sections), we detected no growth of any fungi on reculture attempts for two trees. We strongly suspect that the fungus present in these two trees was *S. pachyodon*. There was no visual evidence in the cross sections of these ten experimental trees indicating the presence of any fungal infections prior to our inoculation.

*Laetiporus sulphureus* was also successfully inoculated into and recultured from 80% (8 of 10) of the experimental trees (table 1). However, in one of these eight trees a different species of fungus (*Phellinus gilvus* (Schw.) Pat.) was also detected when trying to reculture *L. sulphureus*. The two remaining experimental trees were also infected with fungi. One of these trees appeared to have been infected with *Phellinus gilvus* prior to our inoculation. *Phellinus gilvus* was cultured from heartwood tissue during reculturing attempts. The last of the ten trees had a fungus that did not appear to be *Laetiporus sulphureus* and, unfortunately, we were unable to successfully culture

Table 1.--Growth of heartwood decaying fungi inoculated into oaks (*Quercus falcata* and *Q. niger*) in East Texas.

	Species of Fungi	
	<i>Spongipellis pachyodon</i> n = 10	<i>Laetiporus sulphureus</i> n = 10
Success of reisolation	80%	80%
Average 2 year growth above inoculation	31.8 ± 10.1 cm <sup>1</sup>	18.4 ± 5.8 cm
Average 2 year growth below inoculation	25.4 ± 11.3 cm	11.2 ± 1.6 cm
Average annual vertical growth	28.6 cm	14.8 cm
Average annual horizontal growth	5.2 x 2.7 cm	2.6 x 1.4 cm
Other fungi detected in reculture	None	<i>Phellinus gilvus</i> in 2 trees

<sup>1</sup>Mean ± standard deviation.



the fungus. We suspect that this unidentified fungus may have been introduced when we originally drilled the tree.

*Spongipellis pachyodon* grew vertically within the experimental trees at approximately twice the rate of *Laetiporus sulphureus* (table 1). *S. pachyodon* spread at an average vertical rate of 28.6 cm per year while *L. sulphureus* only spread 14.8 cm vertically per year. In three of the five *Spongipellis* inoculated trees that were harvested after 2 years growth white hyphal tissue could be seen growing out of the drill hole around the protruding dowel, almost as if the fungus was beginning to form an external conk or sporophore.

The horizontal growth of *S. pachyodon* averaged 5.2 by 2.7 cm/y (an elliptical area, table 1). This was also approximately twice the dimensions of horizontal growth demonstrated by *L. sulphureus* (2.6 by 1.4 cm/y). The elliptical horizontal growth pattern was caused by the linear nature of the inoculation dowels in the tree. The long axis of the ellipse was parallel to the inoculation dowels.

#### DISCUSSION AND CONCLUSIONS

The technique used to inoculate heart rots into oaks was quite successful. Although *Spongipellis pachyodon* was recultured from only eight of the ten experimental trees, we believe our actual success was 100%. Our actual success with *Laetiporus sulphureus* was less than that with *S. pachyodon*. This, combined with the greater growth rate of *S. pachyodon*, strongly suggests that *S. pachyodon* would be the preferred fungus to use when inoculating trees for woodpeckers.

In the present study we selected only oak trees to test the success of fungal inoculation. *Spongipellis pachyodon*, however, infects many other species of hardwoods. Conner et al. (1976) detected the fungus in *Quercus alba*, *Q. rubra*, *Q.*

*prinus*, *Q. coccinea* as well as *Acer saccharum* and *Carya tomentosa*. Also, an association between hardwood woodpecker nest trees and *S. pachyodon* has already been demonstrated; ten of the 12 hardwood nest trees that Conner et al. (1976) studied intensively were infected with *S. pachyodon* as the primary decay fungus.

*Spongipellis pachyodon* grew within the heartwood of the oaks much faster in vertical directions than horizontally. This is caused in part by compartmentalization of wood tissue (Shigo and Marx 1977). Because *Spongipellis pachyodon* spreads slower horizontally than vertically, enough time must elapse for decay to spread to sufficient diameters to house woodpecker cavities. Trees would have to be inoculated at least 6 years prior to intended use for pileated woodpeckers. Six years might permit the decay column to expand to approximately 31 x 16 cm in diameter, a minimum size for pileated cavities (table 2). It is necessary for the decay column to grow to this sufficient diameter because pileated woodpeckers that are excavating cavities in oaks and most other hardwoods usually stop when they encounter undecayed wood at the bottom and on the sides of nest cavities (Conner et al. 1976).

The time required for sufficient growth of decay from inoculation until potential use by other woodpecker species will be shorter than that for pileateds (table 2). It is also important to note that the sapwood in hardwoods must also be decayed before a snag will be suitable as a nest site for downy woodpeckers and northern flickers because these two species typically cannot excavate through undecayed sapwood (Conner et al. 1976).

When artificial inoculation of hardwood trees is feasible we suggest that *Spongipellis pachyodon* be used as the inoculum as described in our methods section. However, trees should be inoculated at heights close to average nest cavity heights for individual woodpecker species and in

Table 2.--Woodpecker cavity and nest tree characteristics.

Species	Average <sup>1</sup> cavity depth	Average <sup>1</sup> cavity diameter	Time for decay	Average nest height	Optimum D.B.H. ranges of nest trees
	(cm)	(cm)	(years)	(m)	(cm)
Downy woodpecker <i>Picoides pubescens</i>	18	9	3	4.8	15-25
Hairy woodpecker <i>P. villosus</i>	35	11	4	8.8	25-35
Pileated woodpecker <i>Dryocopus pileatus</i>	48	20	6	13.6	45-65
Northern flicker <i>Colaptes auratus</i>	28	14	5	8.5	30-44
Red-bellied woodpecker <i>Melanerpes carolinus</i>	30	10	4	7.6	36-53
Red-headed woodpecker <i>M. erythrocephalus</i>	30	10	4	7.0	40-60

<sup>1</sup> Conner, unpubl. data--nest cavities from both Virginia and Texas.



trees of the appropriate DBH (table 2, Conner et al. 1975, Jackson 1976). If inoculations are made lower in trees than the average nest height, more time would elapse before the fungus would grow to sufficient dimensions at heights favorable to woodpeckers; low nests would probably have increased predation pressure (Dennis 1969, Kilham 1971, DeWeese and Pillsmore 1972). Most woodpeckers would be able to detect the presence and location of heart rots in potential nest trees by percussing the tree and possibly sensing a "special" resonance that indicates a suitable site for excavation (Conner et al. 1976, Conner, pers. obs.).

Numbers of snags (dead or mostly dead trees) needed as cavity sites by woodpeckers to support varying percentages of population maximums (table 3, revised from Evans and Conner 1979) are important if a forest manager decides to create additional potential nest sites by artificial inoculation. The numbers of snags indicated in table 3 include snags for one cavity nest and three roost sites. It is important to consider roost cavity numbers because individual woodpeckers of many species use several during the course of a year, a behavior that may reduce the probability of predation. Our estimates on the number of roost sites preferred by woodpeckers is probably low. Also included in the number of snags needed is a reserve of 9 snags for each cavity required by a pair of woodpeckers during a year. This includes a margin for snags that are unusable for nesting or roosting, a reserve of snags for replacements, and a supply for secondary users (Bull and Meslow 1977, Evans and Conner 1979). Because competition for cavities often occurs, the needs of secondary cavity nesters must be considered. While some of the reserve of snags will be used as foraging substrate, the numbers of snags recommended for cavity requirements will in no way meet the complete foraging needs of the woodpecker species. Until additional data indi-

cate a revision is needed, we suggest that our estimates are conservative. Quantitative data are needed to show what percentage of standing snags are actually suitable for cavity excavation. The numbers of snags we have suggested can be used as a general guideline for forest resource managers wishing to augment available cavity habitat for both primary and secondary cavity nesters.

#### ACKNOWLEDGMENTS

We thank Brian A. Locke and Ben A. Sanders for constructive comments and suggestions on an early draft of the manuscript.

#### LITERATURE CITED

- Balda, Russell P. 1975. The relationship of secondary cavity nesters to snag densities in western coniferous forests. USDA, Forest Service, Southwest. Region Wildlife Hab. Tech. Bull. 1, 37 p. Albuquerque, NM
- Bull, Evelyn L., and E. Charles Meslow. 1977. Habitat requirements of the pileated woodpecker in northwestern Oregon. J. For. 75:335-337.
- Conner, Richard N. 1978. Snag management for cavity nesting birds. p. 120-128 In Proceedings of the Workshop: Management of Southern Forests for Nongame Birds. (R. M. DeGraaf, Tech. Coord.) USDA Forest Service Gen. Tech. Rep. SE-14.
- Conner, Richard N., Robert G. Hooper, Hewlette S. Crawford, and Henry S. Mosby. 1975. Woodpecker nesting habitat in cut and uncut woodlands in Virginia. J. Wildl. Manage. 39:144-150.
- Conner, Richard N., Orson K. Miller, Jr., and Curtis S. Adkisson. 1976. Woodpecker dependence on trees infected by fungal heart rots. Wilson Bull. 88:575-581.

Table 3.--Numbers of snags required to provide cavities to support varying percentages of woodpecker population maximums. (Revised from Evans and Conner 1979 for southern forests)

Species	Snags needed per 4.0 ha for cavities to maintain listed percentages of population maximums				
	Excellent	Good		Fair	Poor
	100	80	60	40	20
----- (number) -----					
Downy woodpecker <i>Picoides pubescens</i>	40	32	24	16	8
Hairy woodpecker <i>P. villosus</i>	20	16	12	8	4
Pileated woodpecker <i>Dryocopus pileatus</i>	5	4	3	2	1
Northern flicker <i>Colaptes auratus</i>	5	4	3	2	1
Red-bellied woodpecker <i>Melanerpes carolinus</i>	27	22	16	11	6
Red-headed woodpecker <i>M. erythrocephalus</i>	20	16	12	8	4



- Dennis, John V. 1969. The yellow-shafted flicker (*Colaptes auratus*) on Nantucket Island, Massachusetts. *Bird-banding* 40:290-308.
- DeWeese, Lawrence R., and Richard E. Pillmore. 1972. Bird nests in an aspen tree robbed by black bear. *Condor* 74:488.
- Dickson, James G., Richard N. Conner, and J. Howard Williamson. 1983. Snag retention increases birds in a clearcut. *J. Wildl. Manage.* 47:799-804.
- Evans, Keith E., and Richard N. Conner. 1979. Snag management. p. 214-225 *In* Management of North Central and Northeastern forests for nongame birds (R. M. DeGraaf and K. E. Evans, Compilers). USDA Gen. Tech. Rep. NC-51.
- Jackson, Jerome A. 1976. A comparison of some aspects of the breeding ecology of red-headed and red-bellied woodpeckers in Kansas. *Condor* 78:67-76.
- Kilham, Lawrence. 1971. Reproductive behavior of yellow-bellied sapsuckers I. Preference for nesting in *Fomes*-infected aspens and nest hole interrelations with flying squirrels, raccoons, and other animals. *Wilson Bull.* 83:159-171.
- Scott, Virgil E., Keith E. Evans, David R. Patton, and Charles P. Stone. 1977. Cavity-nesting birds of North American Forests. USDA For. Serv., Agric. Handbook 511.
- Shigo, Alex L., and Harold G. Marx. 1977. Compartmentalization of decay in trees. USDA, For. Serv. Agric. Info. Bull. 405, 73 pp.
- Silverborg, Savel B. 1959. Rate of decay in northern hardwoods following artificial inoculation with some common heartrot fungi. *For. Sci.* 5:223-228.
- Toole, E. Richard. 1965. Inoculation of bottom-land red oaks with *Poria ambigua*, *Polyporus fissilis*, and *Polyporus hispidus*. *Plant Disease Reporter* 49:81-83.
- Toole, E. Richard. 1966. Comparison of two methods for inoculating nuttall oaks with *Pleurotus ostreatus*. *Plant Disease Reporter* 50:552-553.
- Toole, E. Richard. 1967. Rates of wood decay behind open and closed wounds. *Plant Disease Reporter* 51:600.
- U.S.D.A. 1982. An analysis of the timber situation in the United States 1952-2030. U.S. For. Serv. For. Resource Report No. 23. 499 p.

# The Use of High-Cut Stumps by Cavity-Nesting Birds<sup>1</sup>

Michael L. Morrison, Martin G. Raphael, and Robert C. Heald<sup>2</sup>

---

Abstract.--This paper discusses the use of high-cut stumps by cavity nesting birds. Although high-cut stumps are less hazardous and present little revenue loss compared to taller snags, virtually no information is available on the use of such stumps by birds. Literature sources and research results indicate that few species will readily use such stumps. Creating high-cut stumps is economically feasible, however. It is recommended that high-cut stumps be used as replacements for tall snags only in areas of potential safety hazard.

---

## INTRODUCTION

The use of snags by cavity nesting birds has received increased attention as more forested land has come under intensive management for timber production. As is well known, snags are required as roosting and nesting sites by numerous birds--the density of primary and secondary cavity nesting birds is often directly related to snag density (e.g., Scott 1979, Raphael 1980). Unfortunately, the presence of snags is often in conflict, either real or imaginary, with the conduct of certain forest management practices. For example, snags can pose fire hazards, are sometimes in the path of ground and/or aerial forestry equipment, and can act as health hazards if they fall near roads, trails, or buildings (e.g., see McClelland and Frissell 1975, Scott 1978). In addition, snags are often a readily available source of fuel wood. Thus while snags are a requisite for many forest birds, there are many competing demands for their disposition.

The deterioration of snags complicates their management. As summarized by Thomas et al. (1979), a snag deteriorates from the time the tree dies until its collapse; not all stages of deterioration are suitable for a particular bird species. Even if enough snags are left in a clearcut to provide 100% of the potential population of cavity nesters, this 100% level will immediately begin to decline as the snags continue deteriorating, fall, and otherwise become unsuitable (see Thomas et al. 1979). Therefore, not only are the absolute number and sizes of snags important, but these requisite

snags must be provided continuously in a forest stand to assure a diversity of snag decay classes.

Given the competing demands for snag utilization, and the fact that snags must be supplied during all successional stages of the forest, various proposals have been advanced for ensuring that the needs of cavity nesting birds will be met, including killing trees through herbicide injection, girdling, and use of explosives (e.g., Conner 1978, Bull et al. 1981). Creating artificial nest cavities via routing has also been proposed (Carey and Sanderson 1981). Although snags created through such artificial means are apparently suitable for cavity nesting birds, such snags still present various safety hazards, and are also subject to harvest as fuel wood.

An additional proposal for supplying the needs of cavity nesting birds is the creation of high-cut stumps. The process of "high-stumping" creates snags that are short (usually < 2 m) compared to most natural or artificial snags. These high-cut stumps are less hazardous than taller snags and little revenue in board footage is lost by creating a small versus a tall snag.

As outlined by Thomas et al (1979), birds apparently require snags of a certain minimum height and diameter. The question arises, then, as to whether high-cut stumps will be suitable replacements for taller snags. Although Kroll et al. (1980) suggested that "high-stumping" will provide excellent foraging sites for woodpeckers, we know of no study that has analyzed the use of stumps by cavity nesting birds.

The purpose of this paper is to identify likely results of a program using high-cut stumps prior to actual initiation of such a program on a large scale. We suggest species that will likely use such stumps, as well as an economic analysis of integrating high-cut stumps into a forest management plan.

---

<sup>1</sup>Paper presented at the snag habitat management symposium [Northern Arizona University, Flagstaff, June 7-9, 1983].

<sup>2</sup>Michael L. Morrison is Assistant Professor of Wildlife Biology, Martin G. Raphael is Staff Research Associate, and Robert C. Heald is Manager, Blodgett Forest Research Station, University of California, Berkeley, Calif.



## THE USE OF STUMPS BY BIRDS

Little original information was available on nest and nest-tree heights for cavity nesting birds. Some authors have relied heavily on data presented in the "Bent Life History Series" or on other previously published summaries; much published information is thus repetitive. We made no attempt to analyze data by geographic region because of the paucity of original information; we have, however, generally confined our survey to western North America.

Our survey of the literature indicated that few species readily nest in snags less than 2 m tall (Table 1). Although Bent (see Table 1 for citations) gave the minimum nest heights of most species as near 2 m, the remaining citations indicated that the mean nest height is usually much higher. The only species that appeared to consistently use stumps for nesting was the White-headed Woodpecker (scientific names given in Table 1). Although a detailed analysis of the nesting habits of this species is apparently lacking, most authorities indicated that this species regularly uses snags < 2 m tall.

Bull (1978), Bull et al. (1980), and Thomas et al. (1979) all gave 1.8 to 2.0 m as the minimum nest height for the White-headed Woodpecker and the Northern Flicker (see also Table 1). Other authorities, however, indicate that the flicker usually uses taller snags for nesting (Table 1). Bull et al. (1980) and Thomas et al. (1979) also gave 1.8 m as the minimum acceptable nest height for the Black-backed Woodpecker. Here again, the remaining citations gave much higher nest heights for the Black-backed Woodpecker. Bull et al. (1980) were alone in suggesting that 1.8 to 2.0 m was the minimum acceptable nest height for the Downy Woodpecker, Mountain and Chestnut-backed chickadees, and Western and Mountain bluebirds. It should be noted that E. Bull and J. W. Thomas both conducted their research in northeastern Oregon, a possible reason for the similarity in many of their recommendations.

Cunningham et al. (1980) found (in Arizona) that secondary cavity nesting birds used snags with heights ranging from 2 to 36 m. However, only 2% of the snags (stumps) in the 0-4 m height interval were used; 63% of all snags used were over 20 m tall. They concluded that secondary cavity nesters used cavity heights in proportion to their availability, although on one study area a slight trend for the use of the higher cavities was evident.

The use of stumps and snags by cavity nesting birds was surveyed by Raphael (unpubl. data; see also Raphael 1980, Raphael and White, in press) in the eastern Sierra Nevada. Only one species (Mountain Chickadee) used stumps under 1 m in height (Table 2). Mountain Chickadees also used stumps 1 to 2 m tall, as did the White-headed Woodpecker, Northern Flicker, Mountain Bluebird, and House Wren; the use of stumps by the latter

three species was rare. Use of stumps (snags) under 2 m tall accounted for about 33% of all nest sites for the chickadee; White-headed Woodpeckers were rare in the study area but 25% of their nests were in snags under 2 m tall. Note (Table 2) that only 9% of all nest sites were in snags under 2 m in height; the majority (71%) of all nests were in snags over 5 m tall. Thus while certain species did use stumps for nesting, the distribution of nest sites by height was markedly skewed to the use of tall snags.

Raphael (unpubl. data; 1980) also surveyed the availability of stumps and snags in the study area. Stumps, now defined as < 1.5 m tall, accounted for 60.2% of all standing dead trees, while snags > 1.5 m tall accounted for 39.8% of this material. If snags were defined to include only trees > 38 cm dbh, then stumps accounted for 89.5% of all standing dead trees. In contrast, over 90% of all nests were in snags over 1.5 m in height. Thus, cavity nesting birds appeared to be preferentially using tall snags relative to stumps.

Data presented in this paper indicates that few species will accept stumps as nest sites. One cannot infer nest-site "selection," which denotes that an actual choice between two or more potential nest sites is being made by an individual, without experimental manipulation of stump and snag availability (see below). The data did indicate, however, that the White-headed Woodpecker and the Mountain Chickadee accepted stumps as nest sites. The Northern Flicker and Black-backed Woodpecker may also use stumps as nest sites occasionally.

It is important to note, however, that most primary and secondary cavity nesting birds only infrequently use stumps for nesting. Data indicates that while the range of heights used as nest sites often included stumps, the mean nest height was usually much above 2 m. Further, nest heights can be positively skewed towards taller snags.

Thomas et al. (1979) reported minimum nest heights for cavity nesting birds. Conner (1979) has questioned the use of minimum standards as management guidelines. Conner argued that providing only minimum habitat factors, such as snag height or diameter, may be biologically unsound, and for certain species may cause a decline in abundance because of reduced reproductive success. For example, birds that nest lower than normal in trees may risk increased predation. Conner further suggested that trees should be provided that span either side of the average diameter and height so that the chance of breeding success can be maximized. It is also doubtful that a species could be "forced" to accept smaller snags by eliminating larger ones (Conner 1979). It is important to note that even the minimum nest (or snag) height apparently acceptable for certain species, 1.8 to 2.0 m, is near the maximum height that high-cut stumps can be safely produced (i.e., without the aid of ladders).

Table 1. Nest and tree heights (m) of cavity nesting birds summarized from literature sources.

Species	Nest height		Tree height		Reference <sup>1</sup>
	$\bar{X}$	range	$\bar{X}$	range	
Primary cavity nesters					
Lewis' woodpecker	7.3		11.4		F
<u>Melanerpes lewis</u>	9.1				I
		2-33			J
Acorn woodpecker			12	9-15	E
<u>M. formicivorus</u>		2-12			J
Yellow-bellied Sapsucker			9	6-12	B
<u>Sphyrapicus varius</u>	2.9-6.9	1.1-10.8			C
	12	7-18	18	13-24	E
	17.2	6.1-22.3			H
	4.6				I
		1.7-10			J
Red-breasted Sapsucker	12.8		20.5		F
<u>S. ruber</u>					
Williamson's Sapsucker	2.4-10.3	0.8-16.9			C
<u>S. thyroideus</u>	7	3-18	16	7-30	E
	11.2		19.9		F
	4.6				I
		1.7-2.0			J
Downy Woodpecker			6	3-9	B
<u>Picoides pubescens</u>		2-11			D
	7	6-8	13	12-15	E
	4.7-4.9	1.0-11.6	5.8-8.3	1.5-19.8	G
	4.6				I
		1-17			J
Hairy Woodpecker			9	6-12	B
<u>P. villosus</u>		3-17			D
	10	6-15	18	10-21	E
	4.8		13.7		F
	8.8	2.4-19.8	13.0	4.0-26.5	G
	18.2	7.9-41.8			H
	4.6				I
		1.3-33			J
White-headed Woodpecker	2.0		3.8		F
<u>P. albolarvatus</u>	1.8				I
		1.7-5			J
Three-toed Woodpecker			9	6-12	B
<u>P. tridactylus</u>	10	9-11	16	12-21	E
	4.6				I
Black-backed Woodpecker			9	6-12	B
<u>P. arcticus</u>	2.8		16.8		F
	1.8				I
		1.3-4			J
Northern Flicker			9	6-12	B
<u>Colaptes auratus</u>		3-18			D
	11	3-21	19	7-27	E
	7.7		12.7		F
	8.5-13.7	2.7-21.9	12.4-22.5	9.1-36.0	G
	11.4	3.0-26.8			H
	1.8				I
		0.3-33			J



Table 1 (continued).

Species	Nest height		Tree height		Reference <sup>1</sup>
	$\bar{X}$	range	$\bar{X}$	range	
Pileated Woodpecker <u>Dryocopus pileatus</u>			18	12-21	B
		5-17			D
	7.5-13.6	5.5-19.2	9.8-20.3	7.3-36.6	G
	15.0	7.0-24.1			H
	9.5				I
		5-28			J
Pygmy Nuthatch <u>S. pygmaea</u>	2.9	1.3-6.1			A
	13	2-24	18	9-31	E
	4.7		6.1		F
	9.1				I
		3-8			J
Red-breasted Nuthatch <u>Sitta canadensis</u>	9	4-15	16	4-26	E
	9.2		15.1		F
	27.6	7.0-56.4			H
	4.6				I
		1.7-120			J
Secondary cavity nesters					
Tree Swallow <u>Tachycineta bicolor</u>	12	7-15	21	15-25	E
	4.6		10.3		F
	4.6				I
Violet-green Swallow <u>T. thalassina</u>	12	2-24	19	7-37	E
	4.6				I
		>1.7			J
Mountain Chickadee <u>Parus gambeli</u>	2.4	2.4-3.3			A
	9	2-18	15	3-37	E
	3.5		8.1		F
	1.8				I
		0.7-27			J
Chestnut-backed Chickadee <u>P. rufescens</u>	18.4	1.8-44.8			H
	1.8				I
		<3			J
White-breasted Nuthatch <u>S. carolinensis</u>	2.6	1.5-6.4			A
	9	4-15			E
	5.7		10.2		F
	4.6				I
		5-17			J
Western Bluebird <u>Sialia mexicana</u>	3.7	1.2-7.9			A
	12	6-21	18	9-24	E
	1.8				I
Mountain Bluebird <u>S. curruoides</u>	7	1-12	14	7-24	E
	4.5		6.6		F
	1.8				I

<sup>1</sup>A = Cunningham et al. (1980:Table 8); B = Evans and Cogner (1979:Tables 2 and 3); C = Crockett and Hadow (1975:Table 1)<sup>3</sup>; D = Conner (1978:Table 2); E = Scott et al. (1980:Table 3); F = Raphael (1980:Table 11); G = Conner et al. (1975:Table 1)<sup>3</sup>; H = Mannan et al. (1980:Table 3); I = Thomas et al. (1979:Appendix 19)<sup>2</sup>; J = Bent (1939, 1942, 1946, 1948, 1949).

<sup>2</sup>Values represent minimum nest heights.

<sup>3</sup>Values are the range of means found for several study sites.

Table 2. Use of stumps and snags for nesting by primary and secondary cavity nesting birds in the Sagehen Creek Basin, Tahoe National Forest, California (n = 568 nests).

Species	0 - 1m		1 - 2m		2 - 3m		3 - 4m		4 - 5m		> 5m	
	No.	%	No.	%	No.	%	No.	%	No.	%	No.	%
Lewis' Woodpecker	0	0.0	0	0.0	0	0.0	0	0.0	1	2.7	36	97.3
Red-breasted Sapsucker	0	0.0	0	0.0	1	2.0	1	2.0	0	0.0	48	96.0
Williamson's Sapsucker	0	0.0	0	0.0	1	2.0	0	0.0	2	4.0	47	94.0
Hairy Woodpecker	0	0.0	0	0.0	0	0.0	1	4.3	2	8.7	20	87.0
White-headed Woodpecker	0	0.0	3	25.0	2	16.7	3	25.0	3	25.0	1	8.3
Black-backed Woodpecker	0	0.0	0	0.0	0	0.0	0	0.0	0	0.0	8	100.0
Northern Flicker	0	0.0	1	1.5	5	7.4	6	8.8	4	5.9	52	76.5
Tree Swallow	0	0.0	0	0.0	1	7.1	4	28.6	0	0.0	9	64.3
Mountain Chickadee	22	16.8	22	16.8	15	11.5	5	3.8	8	6.1	59	45.0
Red-breasted Nuthatch	0	0.0	0	0.0	0	0.0	2	6.7	1	3.3	27	90.0
White-breasted Nuthatch	0	0.0	0	0.0	2	8.0	5	20.0	4	16.0	14	56.0
Pygmy Nuthatch	0	0.0	0	0.0	1	3.6	5	17.9	6	21.4	16	57.1
Western Bluebird	0	0.0	0	0.0	0	0.0	1	50.0	1	50.0	0	0.0
Mountain Bluebird	0	0.0	1	2.7	1	2.7	8	21.6	3	8.1	24	64.9
American Kestrel <sup>1</sup>	0	0.0	0	0.0	0	0.0	1	7.7	3	23.1	9	69.2
Brown Creeper <sup>1</sup>	0	0.0	0	0.0	0	0.0	0	0.0	0	0.0	17	100.0
House Wren <sup>1</sup>	0	0.0	2	9.5	1	4.8	2	9.5	2	9.5	14	66.7
European Starling <sup>1</sup>	0	0.0	0	0.0	0	0.0	0	0.0	0	0.0	2	100.0
Total	22	3.9	29	5.1	30	5.3	44	7.7	40	7.0	403	71.0

<sup>1</sup> American Kestrel (*Falco sparverius*); Brown Creeper (*Certhia americana*); House Wren (*Troglodytes aedon*); European Starling (*Sturnus vulgaris*); scientific names of other species in Table 1.

Although our analysis indicates that few species will readily use high-cut stumps should they be provided, only experimental creation of such stumps will give a clear indication of the suitability of such structures as nest sites. We are currently conducting a study that both creates high-cut stumps (see below) and manipulates the density of natural snags. Until such pilot studies are complete, we advise extreme caution be used in attempting to integrate high-cut stumps into a forest management plan. Some preliminary guidelines follow:

1. High-cut stumps should be used only where populations of White-headed Woodpeckers, flickers, and chickadees are present. The use of such stumps

should be directed only towards these species and not be used to reduce the overall number of snags deemed necessary to maintain populations of other cavity nesters.

2. Stumps should be as tall as possible and meet the diameter (dbh) requirements for the species of interest (e.g., see Thomas et al. 1979, Raphael and White, in press).

3. Stumps should be used as a replacement for tall snags only in areas of potential safety hazard (e.g., along roads and trails, near buildings). High-cut stumps along roads will also reduce hazards to timber operators and make equipment operation easier.



4. Guidelines for management of tall snags should also be followed; for example, stumps should be created in groups, rather than as scattered individuals (e.g., see Bull 1978, Evans and Conner 1979).

5. All high-cut (and natural) stumps should be monitored for use by cavity nesting birds; the presence of nest excavations and feeding sign (see Kroll et al. 1980) should be recorded.

#### ECONOMIC ANALYSIS: A CASE STUDY

The probable economic cost of creating high-cut stumps can be estimated by combining several direct expenditures, values foregone, and intangibles. The direct costs include time spent selecting trees for "high stumping," administrative cost involved in incorporating new contractual language, coping with legal restrictions, and any increase in logging costs. The principal values foregone include the wood left in high stumps and any expected loss in site productivity incurred by altering originally planned residual stand conditions. Intangible costs may include disruption of existing timber faller training programs, overcoming professional resource managers' biases, public education, and a potential shift of attention away from other wildlife habitat needs.

At Blodgett Forest Research Station, El Dorado County, California, timber harvesting operations and planning are conducted in a fashion quite similar to both timber industry and federal timber sale programs. The Forest is constrained to comply with all existing California laws and procedures that apply to non-federal forest land in California. Furthermore, operations separate sale of logs from timber harvesting contracts and harvest planning. This facilitates accurate accounting of actual costs. The following example illustrates the costs incurred while incorporating high-cut stumps into harvesting activities at Blodgett Forest. The data are drawn from a variety of partial cutting harvests (including selection, intermediate thinning, seed tree seed step, and overstory removal forest regeneration methods) in young growth (50 to 80 year old) mixed conifer-oak stands on highly productive mid-elevation (1300 meters) sites (index height 30 to 40 meters at 50 years of age, breast height) in the central Sierra Nevada of California. Pre-harvest and residual stand densities varied considerably.

At Blodgett Forest the only quantifiable direct cost of creating high-cut stumps is higher timber falling rates. Additional falling time results from operating the chainsaw in an unusual position and taking extra caution to mitigate the added risk of injury inherent in nonstandard tree falling. Assuming each high-cut stump tree requires three minutes more to fell than the average tree indicates added cost of about \$2 each.

Insignificant additional time is spent by tree marking crews in selecting "high stump" trees. Marking rules are simply modified to include proper guidelines.

Logging costs on average tractor operable terrain should not be significantly adversely affected

by high-cut stumps. Certainly the high-cut stumps would have to be avoided by skidding machines; this potentially could disrupt planned skid trails and increase residual stand damage. Conversely, slightly higher than normal stumps are often prescribed on the inside of skid trail turns to act as "rub trees" and prevent residual stand damage. Some additional breakage in felled trees and residual stand damage might be incurred as timber fallers are forced to adjust falling lead to avoid high stumps. On balance, such costs are either negligible or can be mitigated by judicious selection of trees marked by the forester for use as high-cut stumps.

The unquantifiable direct cost involved dealing with existing state regulations. In 1973 California passed a new Forest Practice Act (CFPA 1973) considered to be among the most stringent in the nation. The Act and associated administrative code requires approval of a Timber Harvesting Plan (THP) before any commercial timber harvesting may take place on non-federal lands in California. Among the numerous rules developed to implement the Act is one (954.2, Southern District Rules) that restricts stumps to a maximum height of 30 cm. The intent of this rule is to reduce the supposed adverse visual effects of stumps and to increase utilization of wood resources. The effect of Rule 954.2 is to render high-cut stumps purely for wildlife habitat illegal. Circumventing this legal problem required filing THP amendments for each proposed harvest area plus the considerable cooperation of Forest Practice Inspectors representing the California Department of Forestry.

The value of marketable wood left is clearly the largest single cost in high-cut stumps. A simple computation of average volume left per stump would seem in order. However, the peculiarities of various scaling rules tends to confound the issue. Assuming an average high stump is 60 cm (dob), 1.4 m taller than normal stumps, and standing trees are valued at \$16 per cubic meter (\$100 per thousand board feet), the value of wood left in the forest is about \$7 per high-cut stump. To whatever extent trees can be selected that have a portion of the high-cut stump cull due to existing disease or damage, the value of wood left in the forest would be reduced. So long as high-cut stumps are selected from trees that would have been cut anyway, there should be no added loss due to poorer site occupancy or distorted residual stand structure. This probably means that groups of high-cut stumps are actually interspersed with residual live trees. These costs may be reduced by selecting trees with low wood value because of cull or species differences in value. The wood left in high-cut stumps also represents volume that timber operators will not harvest. Since these loggers would have to do no more work to yard and load the wood left in high-cut stumps if it was still attached to a log, the dollars that would have been paid for harvesting the wood is value foregone.

Intangible costs are by definition difficult to evaluate. Certainly most forest land managers who have been involved in programs designed to increase wood fiber utilization will be somewhat reluctant to appear to be retreating on low stump height requirements. Many foresters will undoubtedly view a high-cut stump program as further erosion of



their perceived principal mission of wood production. The general public may view the stumps as eyesores. All of these problems are surmountable by advertising the value (if they have some) of high-cut stumps in standard programs designed to communicate the habitat needs of wildlife.

In summary, the accountable cost of creating high-cut stumps given the conditions at Blodgett Forest are approximately \$9/stump. Most other costs and (nonhabitat) benefits are negligible or compensating assuming reasonably well applied sale administration and planning. In our case, creating one group of 3 to 5 high stumps per 4 hectares results in an average timber sale net revenue reduction of \$9 per hectare.

#### LITERATURE CITED

- Bent, A. C. 1939. Life histories of North American woodpeckers. U.S. Nat. Mus. Bull. 174. 334 pp.
- Bent, A. C. 1942. Life histories of North American flycatchers, larks, swallows, and their allies. U.S. Nat. Mus. Bull. 179. 555 pp.
- Bent, A. C. 1946. Life histories of North American jays, crows, and titmice. Part 2. U.S. Nat. Mus. Bull. 191:215-495.
- Bent, A. C. 1948. Life histories of North American nuthatches, wrens, thrashers, and their allies. U.S. Nat. Mus. Bull. 195. 475 pp.
- Bent, A. C. 1949. Life histories of North American thrushes, kinglets, and their allies. U.S. Nat. Mus. Bull. 196. 452 pp.
- Bull, E. L. 1978. Specialized habitat requirements of birds: snag management, old growth, and riparian habitat, p. 74-82. In R. M. De Graaf, ed., Proc. Workshop Nongame Bird Habitat Manage. Coniferous Forests Western United States. USDA For. Serv. Gen. Tech. Rep. PNW-64. 100 pp.
- Bull, E. L., A. D. Partridge, and W. G. Williams. 1981. Creating snags with explosives. USDA For. Serv. Res. Note PNW-393. 4 pp.
- Bull, E. L., A. D. Twombly, and T. M. Quigley. 1980. Perpetuating snags in managed mixed conifer forests of the Blue Mountains, Oregon, p. 325-336. In R. M. De Graaf, ed., Workshop Proc. Manage. Western Forests and Grasslands Nongame Birds. USDA For. Serv. Gen. Tech. Rep. INT-86. 535 pp.
- Carey, A. B., and H. R. Sanderson. 1981. Routing to accelerate tree-cavity formation. Wildl. Soc. Bull. 9:14-21.
- Conner, R. N. 1978. Snag management for cavity nesting birds, p. 120-128. In R. M. De Graaf, ed., Proc. Workshop Manage. Southern Forests Nongame Birds. USDA For. Serv. Gen. Tech. Rep. SE-14. 176 pp.
- Conner, R. N. 1979. Minimum standards and forest wildlife management. Wildl. Soc. Bull. 7:293-296.
- Conner, R. N., R. G. Hooper, H. S. Crawford, and H. S. Mosby. 1975. Woodpecker nesting habitat in cut and uncut woodlands in Virginia. J. Wildl. Manage. 39:144-150.
- Crockett, A. B., and H. H. Hadow. 1975. Nest site selection by Williamson and red-naped sapsuckers. Condor 77:365-368.
- Cunningham, J. B., R. P. Balda, and W. S. Gaud. 1980. Selection and use of snags by secondary cavity-nesting birds of the ponderosa pine forest. USDA For. Serv. Res. Pap. RM-222. 15 pp.
- Evans, K. E., and R. N. Conner. 1979. Snag management, p. 214-225. In R. M. De Graaf and K. E. Evans, ed., Proc. Workshop Manage. Northcentral and Northeastern Forests Nongame Birds. USDA For. Serv. Gen. Tech. Rep. NC-51. 268 pp.
- Kroll, J. C., R. N. Conner, and R. R. Fleet. 1980. Woodpeckers and the southern pine beetle. USDA For. Serv. Agric. Handb. No. 564. 23 pp.
- Mannan, R. W., E. C. Meslow, and H. M. Wight. 1980. Use of snags by birds in Douglas-fir forests, western Oregon. J. Wildl. Manage. 44:787-797.
- McClelland, B. R., and S. S. Frissell. 1975. Identifying forest snags useful for hole-nesting birds. J. For. 73:414-417.
- Raphael, M. G. 1980. Utilization of standing dead trees by breeding birds at Sagehen Creek, California. Ph.D. Thesis, Univ. California, Berkeley. 195 pp.
- Raphael, M. G., and M. White. In press. Use of snags by cavity-nesting birds in the Sierra Nevada Mountains. Wildl. Monogr.
- Scott, V. E. 1978. Characteristics of ponderosa pine snags used by cavity-nesting birds in Arizona. J. For. 76:26-28.
- Scott, V. E., J. A. Whelan, and P. L. Snoboda. 1980. Cavity-nesting birds and forest management, p. 311-324. In R. M. De Graaf, ed., Workshop Proc. Manage. Western Forests and Grasslands Nongame Birds. USDA For. Serv. Gen. Tech. Rep. INT-86. 535 pp.
- Thomas, J. W., R. G. Anderson, C. Moser, and E. L. Bull. 1979. Snags, p. 60-77. In J. W. Thomas, ed., Wildlife habitats in managed forests. The Blue Mountains of Oregon and Washington. USDA For. Serv. Agric. Handb. No. 553. 512 pp.



# Direct Habitat Improvements — Some Recent Advances<sup>1</sup>

Andrew B. Carey and John D. Gill<sup>2</sup>

---

Abstract.--Den boxes can be made smaller, more accessible, and more resistant to predators by adding an inside shelf just below the entrance. Boxes placed on the lee sides of trees were preferred by squirrels in winter but not in spring or summer. And den boxes can raise the carrying capacity of young forest for sciurids. Using a chain saw to create tree cavities to be covered with a wooden faceplate is more efficient than routing dens with a drill or creating dens with a chain saw and chisel. Small woodpeckers will excavate cavities in styrofoam cylinders. These "plastic trees" offer some intriguing management and research applications.

---

## INTRODUCTION

Carey and Sanderson (1981) reviewed the literature<sup>3</sup> on formation and value of cavities and provision and use of nest boxes; thus, we will cite only recent literature in this paper. Animals that use cavities receive two major benefits: shelter from the elements (especially for energy conservation) and safety from disturbance, especially predation (Alerstam and Hogstedt 1981, McComb and Noble 1981a, Slagsvold 1982). A principle objective of direct habitat improvements for cavity-using wildlife is to restore the benefits lost through silvicultural, agricultural, or mining activities. Attempts to make up for the lack of naturally formed cavities in second-growth and managed forest fall into two general categories: provision of artificial structures and acceleration of the cavity-forming process. Our purpose is to describe ways of efficiently and effectively providing shelter for some cavity-using wildlife. We discuss artificial structures, acceleration of cavity formation, and why, when, and where direct habitat improvements are appropriate.

---

<sup>1</sup>Paper presented at the Snag Habitat Management Symposium, Northern Arizona University, Flagstaff, 7-9 June 1983.

<sup>2</sup>When most of the work reported here was done, Carey was research wildlife biologist and Gill was project leader, Northeastern Forest Experiment Station, USDA Forest Service, Morgantown W. Va. Now, Carey is research coordinator, Old Growth Forest Wildlife Habitats Program, USDA Forest Service, Olympia, Wash. and Gill is research wildlife biologist, Northeastern Forest Experiment Station, USDA Forest Service, Amherst, Mass.

<sup>3</sup>Reprints available from Carey. Forestry Sciences Laboratory, 3625 93rd Avenue SW, Olympia, WA 98502.

## ARTIFICIAL STRUCTURES

Wooden boxes are the most commonly provided artificial structures for denning, nesting, or roosting. Metal, cement and sawdust, rubber (tire), and polystyrene structure also are used. Boxes can and should be tailored for particular species; plans (and species-specific dimensions) are readily available (Burt 1979, Gary and Morris 1980, Hardin and Evans 1977, Yoakum et al. 1980). The metal, wooden, and rubber structures are well known and widely used. Scott et al. (1980) reported that cement and sawdust boxes are preferred in Europe because they are more durable, harbor fewer ectoparasites, and are better insulators than wooden boxes. Here we present an unpublished nest-box design for squirrels (*Sciurus*, *Tamiasciurus*, and *Glaucomys*), a discussion of optimum nest-box orientation, and a new development--plastic trees.

### An Improved Nest Box For Squirrels

The best-known nest box for squirrels is the modified Barkalow-and-Soots box (fig. 1; Yoakum et al. 1980). Vagn Flyger<sup>4</sup> designed a wooden box (fig. 1) that is superior to the Barkalow-and-Soots box: it is smaller, therefore more portable, easier to place, and cheaper to construct; the entrance is square and at the corner of the face board, making construction simpler; it is easy to make the entrance size small (and line it with sheet metal to prevent gnawing) during construction to produce a box that excludes gray squirrels (*S. carolinensis*) and fox squirrels (*S. niger*) but admits flying squirrels (*G. volans* or *G. sabrinus*);

---

<sup>4</sup>Flyger, V. 1983. Personal conversation. Department of Animal Science, University of Maryland, College Park, Md.



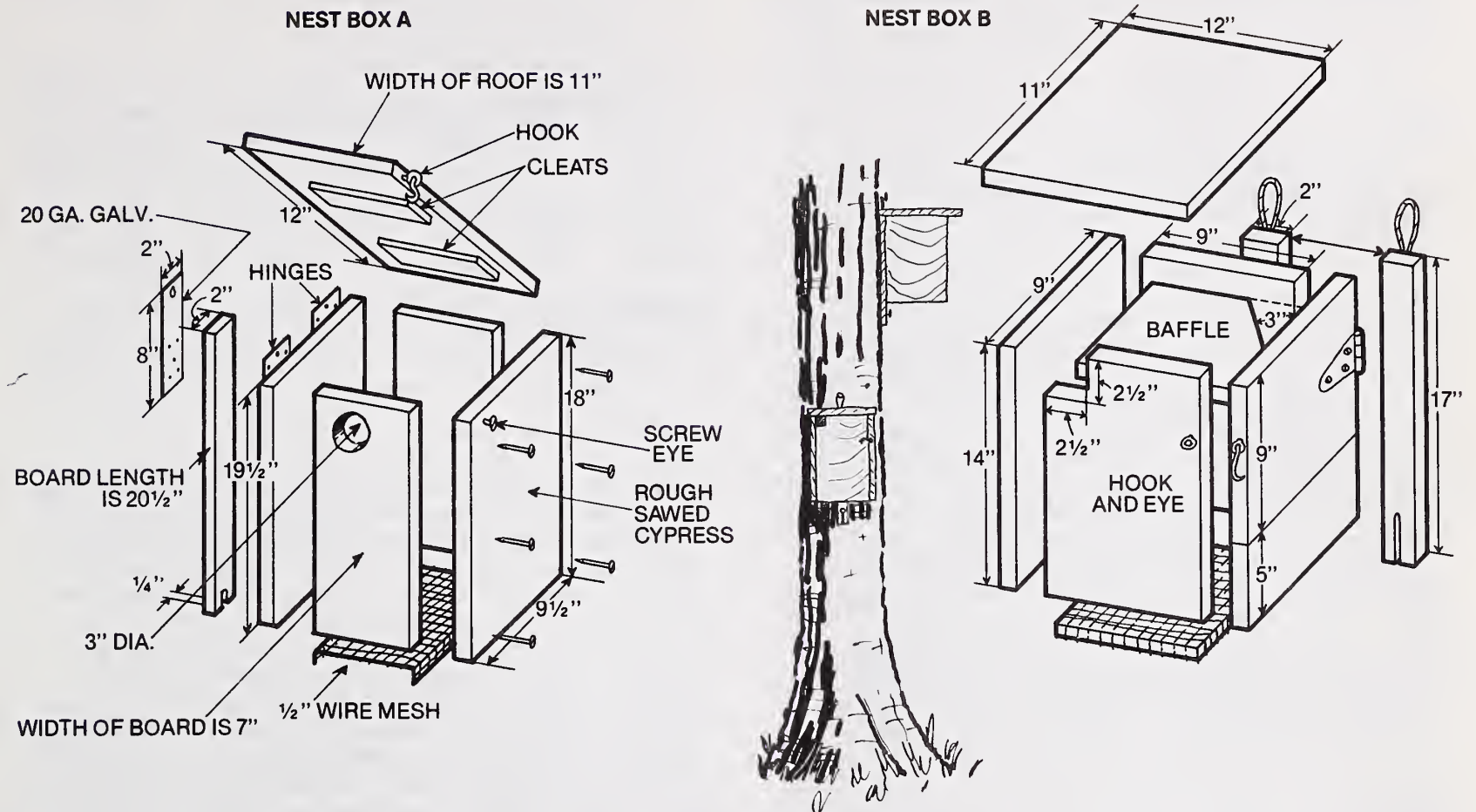

Figure 1. Comparison of two nest boxes: A is the Barkalow-and-Soots box, B is the Flyger box. Note the shelf in box B and the smaller size of B. Wooden bottoms result in higher use than wire-mesh bottoms.

the shelf, just below entrance height with a second entrance in the far corner, makes the box more resistant to predators, allows the box to be smaller, and provides a protected loafing spot for squirrels (which often rest on top of the Barkalow-and-Soots box), the shelf probably helps to prevent heat loss; access to the box interior is through the side, making it easier to inspect and clean the box and to capture animals using the box. If the box is to be used primarily to capture animals, the shelf should be hinged or narrowed to 8 cm to make it easier to remove animals. Flyger has erected more than 3,000 of his boxes in Maryland and has used them for several years in his research on gray squirrels, fox squirrels (including the endangered *S. n. cinereus*), and southern flying squirrels. Flyger recommends using wooden bottoms, but not mesh bottoms, in the nest boxes. He found that boxes with wooden bottoms received much greater use than boxes with mesh bottoms.

Gray squirrels, fox squirrels, red squirrels (*T. hudsonicus*), and southern flying squirrels (up to 25 per box) readily used the boxes. Screech owls (*Otus asio*), European starlings (*Sturnus vulgaris*), and other animals (mammals, birds, amphibians, reptiles, and invertebrates) were occasionally found in the boxes. Use of nest boxes by a wide array of species is common (Carey and Sanderson 1981; McComb and Noble 1981b, 1981c, 1982). If blowfly (*Apaulina* spp.)

parasitism in nest boxes is common in the area in which boxes will be placed, constructing a bowl-shaped floor for the boxes can reduce the level of parasitism (Pinkowski 1977). European starlings often usurp boxes set out for other birds, but Flyger observed that gray squirrels ate the eggs and young of European starlings.

#### Placement of Nest Boxes

Sanderson (1975) gave directions on placement of nest boxes, but he did not recommend a particular side (aspect) of the tree or an aspect for the box entrance. Because construction and placement of nest boxes is labor intensive and costly, the boxes should be placed optimally to provide maximum shelter and safety for the squirrels and in such a way as to obtain the greatest use by squirrels. Franz Pogge<sup>5</sup> (under the direction of J. D. Gill) conducted a study to determine if gray squirrels and southern flying squirrels preferred boxes on particular sides of trees or with entrances facing particular directions. He also

<sup>5</sup>Pogge, F. P. 1981. Squirrel den exposure and multiple winter den use. Final Report, Study FS-NE-1702-18; unpublished report. USDA Forest Service. Forestry Sciences Laboratory, Morgantown, W.Va.



wanted to know how a surplus of boxes would be used and what the effect of boxes would be on the leaf-nest building behavior of gray squirrels.

### Methods

Forty Barkalow-and-Soots nest boxes were placed in the 0.85-ha enclosure described by Sanderson and Berry (1972). Four boxes were attached to each of 10 trees, 7 m above the ground, on the NE, SE, SW, and NW sides of the trees (prevailing winter winds were from the NW). The boxes had entrances on their sides and next to the tree; thus the entrances were at right angles to the box orientation. One-half of the boxes had their entrance to the right, one-half to the left. The boxes were examined for use by gray squirrels and southern flying squirrels during 1979-81. Ten or 11 gray squirrels were kept in the enclosure, close to the optimum described by Berry et al. (1978). As an ancillary study in 1979, one box was placed on each of the wire-mesh walls (with entrances facing N, S, W, or W) of eight 3 x 3-m pens. Thus, none of the boxes was protected from the wind by a tree trunk. Two gray squirrels were kept in each of six pens, one in the seventh, and three in an eighth pen. The boxes were checked for use twice in January and once in March.

### Results

It was common for gray squirrels to use more than one box for nesting and for more than one gray squirrel to be found in a box. Gray squirrels clearly preferred boxes on the SE side of trees for nests during late fall and winter (table 1). Other boxes were used for feeding. No clear preference for nest entrance location was apparent when all boxes were considered (table 2), but

Table 1. Proportions of 40 nest boxes used by gray squirrels during November-March: effect of box aspect.

Period	Inspections <sup>1</sup> of boxes (N)	Aspect of tree stem where box was attached			
		SE	SW	NW	NE
Jan-Mar 1979	2	0.50	0.05	0.05	0.00
Nov-Mar 1979-80	7	0.21	0.13	0.14	0.04
Nov-Mar 1980-81	7	0.17	0.06	0.13	0.23
Average		0.27	0.08	0.11	0.09

<sup>1</sup>Inspection dates were 19 January, 7 March 1979; 11 November, 17 December, 1 and 21 January, 12 February, 3 and 24 March 1979-80; and 10 and 25 November, 10 December, 12 and 28 January, 26 February, and 23 March 1980-81.

Table 2. Proportions of 40 nest boxes used by gray squirrels during November-March: effect of box-entrance aspect.

Period <sup>1</sup>	Aspect of box entrance				Preferred aspects
	SE	SW	NW	NE	
1979	0.00	0.35	0.05	0.20	SW
1980	0.03	0.17	0.13	0.20	NE
1981	0.03	0.07	0.24	0.24	NW, NE
Average	0.02	0.20	0.21	0.21	SW, NW, NE

<sup>1</sup>Numbers of inspections and their dates are in Table 1.

there was a clear preference for NE entrances over SW entrances to boxes on the SE side of trees (2:1 preference). In the 3 x 3-m study, all of the squirrels used the same box for nesting and the other boxes for feeding. There was a clear preference for E-facing entrances. Southern flying squirrels also preferred boxes on the SE side of trees. Up to 14 southern flying squirrels were found in single boxes and up to 42 used boxes in the 0.85-ha enclosure at any one time. Southern flying squirrels also used unoccupied boxes for feeding and defecating. Supplemental food (corn) was provided for the squirrels in the enclosure.

During spring and summer, there was no preference for box or entrance orientation by gray squirrels, including females rearing litters. The use of multiple boxes and leaf nests was common. Females commonly moved their litters to and from leaf nests and nest boxes. In 1978, five females moved their litters 21 times during July to September. One squirrel moved her litter three times, two moved their litters four times, and two moved their litters five times. The mean distance moved was 25.2 m, ranging from 18.5 to 82.0 m. We believe that 10 movements resulted from the technician's inspections of the boxes.

The surplus of boxes did not inhibit leaf-nest building. Nine to eleven gray squirrels and 10 boxes were in the enclosure during 1973-78; the gray squirrels built an average of 14 leaf nests per year. After 30 boxes were added in 1979, the squirrels built 24 leaf nests; in 1980 they built 12 leaf nests before the study ended in July. Leaf-nest building seemed tied to individual behavior because adult squirrels varied greatly in nest-building and consistently built nests (six nests in 3 years). Three to seven other squirrels built nests in any one year. The death of the nest-building pair resulted in a lower than average number of nests being built in the succeeding 3 years, even though the number of adult squirrels was kept the same.

In addition, to the squirrels, deer mice (*Peromyscus* sp.), white-breasted nuthatches (*Sitta carolinensis*), northern flickers (*Colaptes auratus*), and a variety of invertebrates used the boxes.



## Conclusion

In the winter, gray squirrels preferred nest boxes that were sheltered from the wind and whose entrances faced the morning sun. Flying squirrels had similar preferences. Thus, we recommend that nest boxes be placed on the lee side of trees with entrances facing east. The placement should be taken into account during construction so that the side door is away from the tree to facilitate maintenance or inspection.

Leaf-nest building is unrelated to the availability of nest boxes (and presumably natural dens) and the presence of leaf nests does not suggest a lack of other nest sites.

Surplus boxes (those not required for nesting) are used for feeding and other activities; presumably, they help squirrels conserve energy and protect them from predators. The importance of such additional refuges to squirrels is unknown.

## Plastic Trees

Tom Grubb<sup>6</sup> proposed that polystyrene (Styrofoam) cylinders might provide easily constructed portable roost and nest-cavity substrate for woodpeckers that could be used as a research tool or to mitigate the effects of clearcutting or surface mining. Peterson<sup>7</sup> tested the cylinders in the laboratory and found that excavating in polystyrene was not deleterious to the health of woodpeckers. Downy woodpeckers (*Picoides pubescens*) excavated 51 roost cavities in forty-two 242 x 22-cm cylinders during field tests. Carolina chickadees (*Parus carolinensis*) and house wrens (*Troglodytes aedon*) subsequently used 30 of the cavities as nest sites. Raccoons (*Procyon lotor*) destroyed 18 cavities; Peterson suggested using aluminum funnels of the kind used on bird feeders to protect the cylinders. Grubb (1982) used the cylinders to study the snag-height preferences of downy woodpeckers. Ongoing research includes using polystyrene cylinders to attract woodpeckers to clearcuts on the Wayne-Hoosier National Forest to control the red oak borer (*Enaphalodes rufulus*). Further details are presented by Grubb elsewhere in this symposium.

## ACCELERATING CAVITY FORMATION

Sanderson (1975) suggested cutting 8-cm-diam. branches to leave 15-cm stubs on trees to accelerate cavity formation; but the cavity-forming process would still be long, perhaps 6-20 years. Conner (1978) suggested girdling trees to provide foraging and cavity substrate for woodpeckers. We have

<sup>6</sup>Grubb, T. C. 1979. Personal correspondence. Department of Zoology, Ohio State University, Columbus.

<sup>7</sup>Peterson, A. W. 1981. Artificial trees as a nest and roost hole substrate for woodpeckers. 34 p. Unpublished M.S. Thesis, Ohio State University, Columbus.

observed a number of girdled hardwoods (girdling was done to improve timber values) in the Appalachians that had been fed upon or that had had cavities excavated in them. But such trees rot from the outside in (sapwood to heartwood), and once the rot had progressed far enough to allow excavation the trees became fragile and easily destroyed. Conner et al. (1981) examined herbicide-killed trees and believed that the potential of these trees as cavity substrate was good, though none of the 41 trees examined had cavities.

McComb and Ramsey (1983) reported that herbicide-killed trees were acceptable foraging sites for cavity-nesters and that 5-11% of the trees were excavated for cavities; they recommend the technique for supplying a sustained yield of dead trees. But Conner et al. (1981) cautioned that the herbicides might have deleterious effects on woodpeckers or their prey. Bull et al. (1981) suggested using explosives to blow out the tops of trees to accelerate cavity formation, but treetops became tangled in the canopy and the explosive failed to completely shear tops that already contained rot.

Carey and Sanderson (1981) reported the results of boring holes in trees and concomitantly innoculating the trees with fungi. The process was arduous and required a portable generator; inoculation of fungi had little benefit because of the ubiquitousness of decay-causing fungi. Although the rudimentary cavities were quickly used by deer mice and flying squirrels, the trees began to heal by forming callus over the holes. Gano and Mosher (1983) created cavities by removing a section of a tree with a chain saw, excavating wood with a chisel, and replacing the removed section (with a hole bored through it). The procedure was laborious and time consuming (1-1/2 hours per tree) and 37% of the trees fell within 1 year. Here we provide an update on routing trees to accelerate cavity formation and an unpublished technique (and new equipment) for creating cavities with a chain saw.

## Routing to accelerate cavity formation

After 3 years, 18% of the holes had been closed by callus, but 80% of them were being used by southern flying squirrels for feeding and denning (Carey and Sanderson 1981). By the fifth fall after routing, southern flying squirrels and deer mice had begun raising young in the routed holes; the number of young reared is unknown. In year five, 28 of 139 holes were being used as nests by southern flying squirrels and 53 holes were being used for feeding. Deer mice used five holes. Thus, 62% of the holes were being used in the fall. Six years after routing, 19 nests of southern flying squirrels, 6 nests of deer mice, and 1 bird (species unknown) nest were found in the holes in the fall. Total use was 40%, and 20% of the cavities had been closed by callus. Thus, it appears that the quality of the cavities had improved (young were being raised) and that closure by callus was slowing (only an additional 2% closed in 3 years). The cavities were still unattractive to birds.



New routing equipment was developed<sup>8</sup> that was safe and easy to use and that could create gourd-shaped cavities with small entrances. But a portable generator still was required and the small entrances would be even more subject to closure by callus than those we previously routed (if routing had been in a live hardwood). Although the improved equipment produces a readily usable cavity, we are not reporting the design here because we believe that the following technique is superior.

#### Creating cavities with a chain saw

Using a chainsaw to create a hole in a tree and covering the hole with a wooden faceplate with an entrance hole in it to produce a cavity for secondary cavity-nesters (fig. 2) was first done on the Avery Ranger District of the Idaho Panhandle National Forest.<sup>9</sup> Mark Orme created 40 cavities in dead trees in clearcuts in 1978. By the following year, 80% of these cavities were being used by birds. In 1979, another 12-15 were created, and all were used by the following year. The principal species using the cavities were mountain bluebirds (*Sialia currucoides*) and house wrens (*Troglodytes aedon*), but at least one red-breasted nuthatch (*Sitta canadensis*) occupied one of the cavities. In 1980, cavities were constructed in living trees, but it was not possible to determine their use. Eli Milodragovich<sup>8</sup> later developed an improved chain saw that is safe to use for creating cavities when the operator is fully trained and experienced, and has standard safety equipment for tree climbing and sawing (Swedish climbing ladders, safety belts, gloves, chaps, ear protectors, goggles). Several features of the improved chain saw are important: the chain saw must have a compression release for easy, safe starting on the ladder and must be compact and light; a sprocket-nose blade must be used (solid nose blades are quickly damaged); an 8-inch blade must be fashioned from a 12-inch blade (fig. 3); a low-profile, antikick chain--a "chisel chain"--must be used, and a kickback guard (fig. 3) must be installed to act as a chain brake. If the chain kicks back, the guard contacts the wrist and is pivoted to a position over the bar and chain, preventing chain contact with the operator. Faceplates, entrance holes, and cavity size can be tailored to particular species. Faceplates are fashioned before going into the forest and should be attached to the tree with nonferrous nails. Actual cavity construction in live hardwood trees (even in below-freezing weather) requires 8 minutes or less and is less arduous than routing holes with a drill. The cavity thus constructed would be available for immediate use. Callus formation would serve only to further fasten the faceplate to the tree. Cavities produced in this

#### SCHEMATIC FOR CONSTRUCTING CAVITIES: HOLE SIZE IS EXAGGERATED RELATIVE TO TREE DIAMETER.

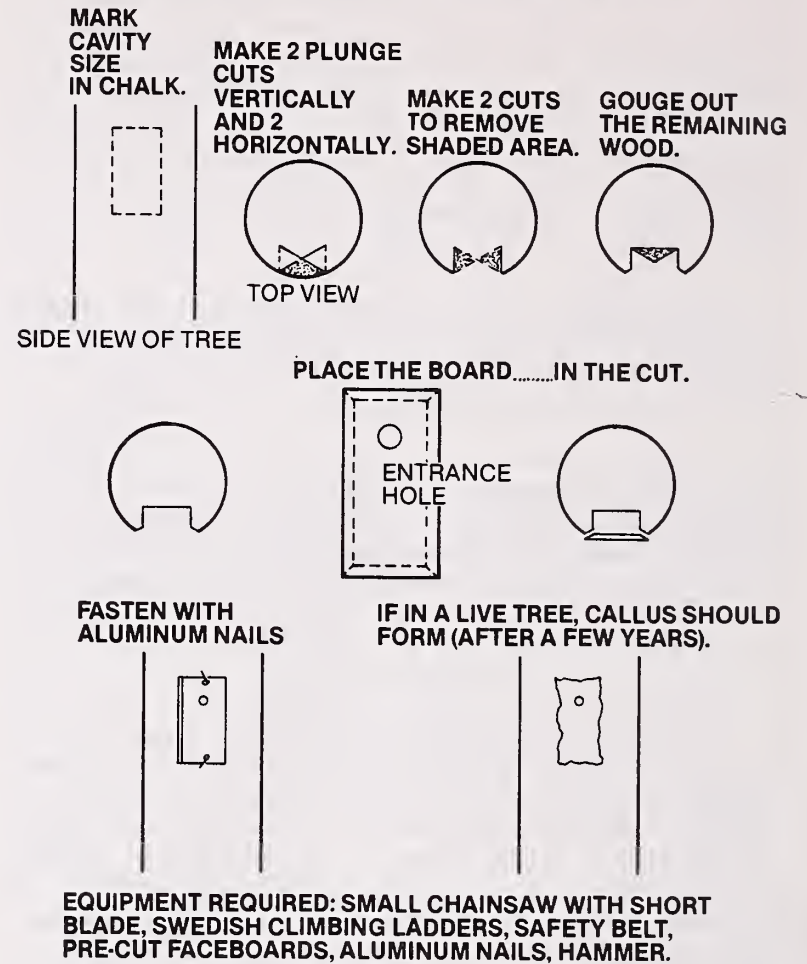

Figure 2. A procedure for constructing cavities with a chain saw.

manner should be more secure, better insulated, and longer lasting than nest boxes, and in time would allow the same succession of users that naturally formed cavities do. These cavities also would be unobtrusive and therefore less subject to vandalism than nest boxes.

#### IMPLEMENTING DIRECT HABITAT IMPROVEMENTS

Providing artificial structures and accelerating cavity formation are not substitutes for amenable environments for cavity-nesting wildlife, or even substitutes for cavity trees. A cavity in a tree is but one part of a varied resource: the tree may be infested with insects that provide food for cavity-using birds; its roots may have hypogeous ectomycorrhizal fungi that produce fruiting bodies that are important food for squirrels and small mammals; other fungi infect the trunk and limbs; the tree may dependably produce large amounts of mast; more than one species may use cavities in the tree or crevices in the bark; the cavities themselves may accommodate a succession of users; a live cavity-tree may die while standing to produce substrate for excavation of cavities by other species; or the tree may fall and provide food and shelter for still other species. The tree itself is but one element of an environment that produces food, cover, suitable microclimate, and

<sup>8</sup>Milodragovich, E. 1980. Demonstration on the National Forests in North Carolina. USDA Forest Service Equipment Development Center, Missoula, MT.

<sup>9</sup>Orme, M. L. 1983. Personal conversation. Targhee National Forest, St. Anthony, ID.



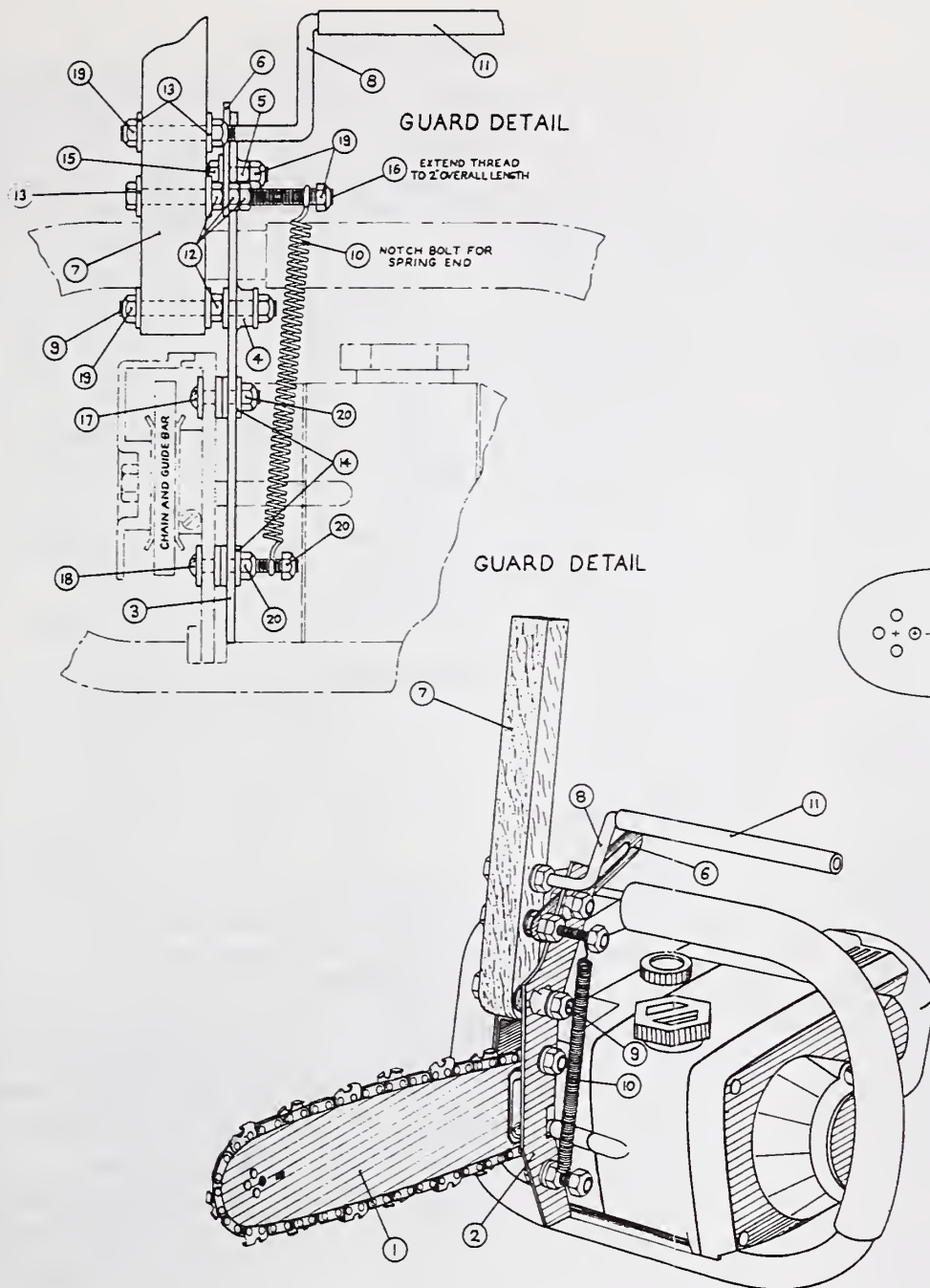

MATERIALS LIST				
NO	PART NAME	REQD	MATERIAL DESCRIPTION	SHEET
1	GUIDE BAR	1	CHAIN SAW GUIDE BAR, 12" HOMELITE #PT-12371-E4, OR EQ	2
2	MOUNTING BRACKET	1	PARTS 3-5	
3	BRACKET	1	10 GA SHEET, COLD ROLLED, STEEL	
4	BUSHING	1	3/16 X 1/4 LG ROUND, COLD ROLLED, STEEL	
5	GUIDE LINK FASTENER	1	1/4 - 20 HEX NUT, NONPLATED	
6	GUIDE LINK	1	14 GA SHEET, COLD ROLLED, STEEL	2
7	GUARD	1	1 X 3/4 OAK OR EQ. HARD WOOD	2
8	ACTUATOR ARM	1	1/2 ROUND, COLD ROLLED, STEEL	2
9	PIVOT BOLT	1	1/4 - 20 - 1/2	2
10	EXTENSION SPRING	1	3/8 X 2 1/2 X 1 1/8 EA. HE MASTER-CARR # B652K56 OR EQ	
11	ARM COVER	1	1/2 ID X 3/2 WALL, NEOPRENE TUBING	
12	NUT	4	1/4 - 20 HEX NUT, PLATED	
13	WASHER	9	1/4 - 20 FLAT WASHER, PLATED	
14	WASHER	8	3/16 - 20	
15	BOLT	1	1/4 - 20 X 3/4 LG HEX HEAD, PLATED	
16	BOLT	1	1/4 - 20 X 3 LG	
17	BOLT	1	10 - 24 X 1 LG ROUND HD, MACHINE SCREW, PLATED	
18	BOLT	1	10 - 24 X 1 1/2 LG	
19	NUTS	6	1/4 - 20 HEX STOP NUT, PLATED	
20	NUTS	3	10 - 24	

DESIGNED FOR USE WITH HOMELITE MODEL SEZ-AO

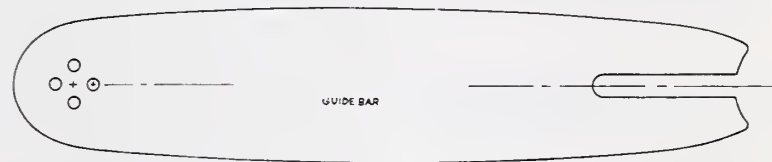

This is a REDUCED PRINT, full size print available upon request.

UNLESS OTHERWISE SPECIFIED:	DATE	REVISION	BY
TOLERANCES: FRACTIONS ± — DECIMALS ± — ANGLES ± —	U.S. DEPT. OF AGRICULTURE FOREST SERVICE EQUIPMENT DEVELOPMENT CENTER MISSOULA, MONTANA		
DIMENSIONS ARE IN INCHES SHARP CORNERS			
DRAWN W A KILROY	TITLE CHAIN SAW FOR MAKING TREE DENS		
DESIGNED	SHEET 1 of 2		
CHECKED	MEDC-665		
APPROVED			
SCALE NOTED			
DATE			

Figure 3A. Modifications to chain saws that are used for constructing cavities. Drawing 1 of 2.

behavioral stimuli. Different environments harbor different mixes of species, and environmental structure may influence which species can coexist. Thus, meeting legal mandates to ensure viable populations of all indigenous wildlife will not be accomplished through the techniques described in this paper.

The technique and structures are appropriate for some kinds of research. They can be of great value in interpretative programs on natural history. They can be used for attracting or increasing the density of certain species in areas used by the public to observe wildlife; for example, along nature trails. They promote consideration for wildlife on private lands through extension services. Direct habitat improvements have successfully increased populations of gray squirrels, fox squirrels, wood ducks (*Aix sponsa*), American kestrels (*Falco sparverius*), eastern bluebirds (*Sialis sialis*),

and other species; Yoakum et al. (1980) and Carey and Sanderson (1981) provided reviews. For example, Nixon and Donohoe (1979) reported that 6-8 nest structures per hectare increased the density of gray squirrels in 30-to 60 year-old hardwood forests where dens were lacking but food was abundant. In many of our second-growth forests, snags and cavity-trees are few or lacking. Using the techniques discussed can allow some cavity-dependent wildlife to exist where they would otherwise be absent. Such mitigative measures have been and can be applied on reclaimed surface mines.

Direct habitat improvements may prove to have substantial value in attracting, restoring, or increasing populations of certain species of wildlife for a variety of purposes. Artificial structures are commonly used in the South to attract purple martins (*Progne subis*) to control mosquitoes and heartworm in dogs. The use of nest boxes in



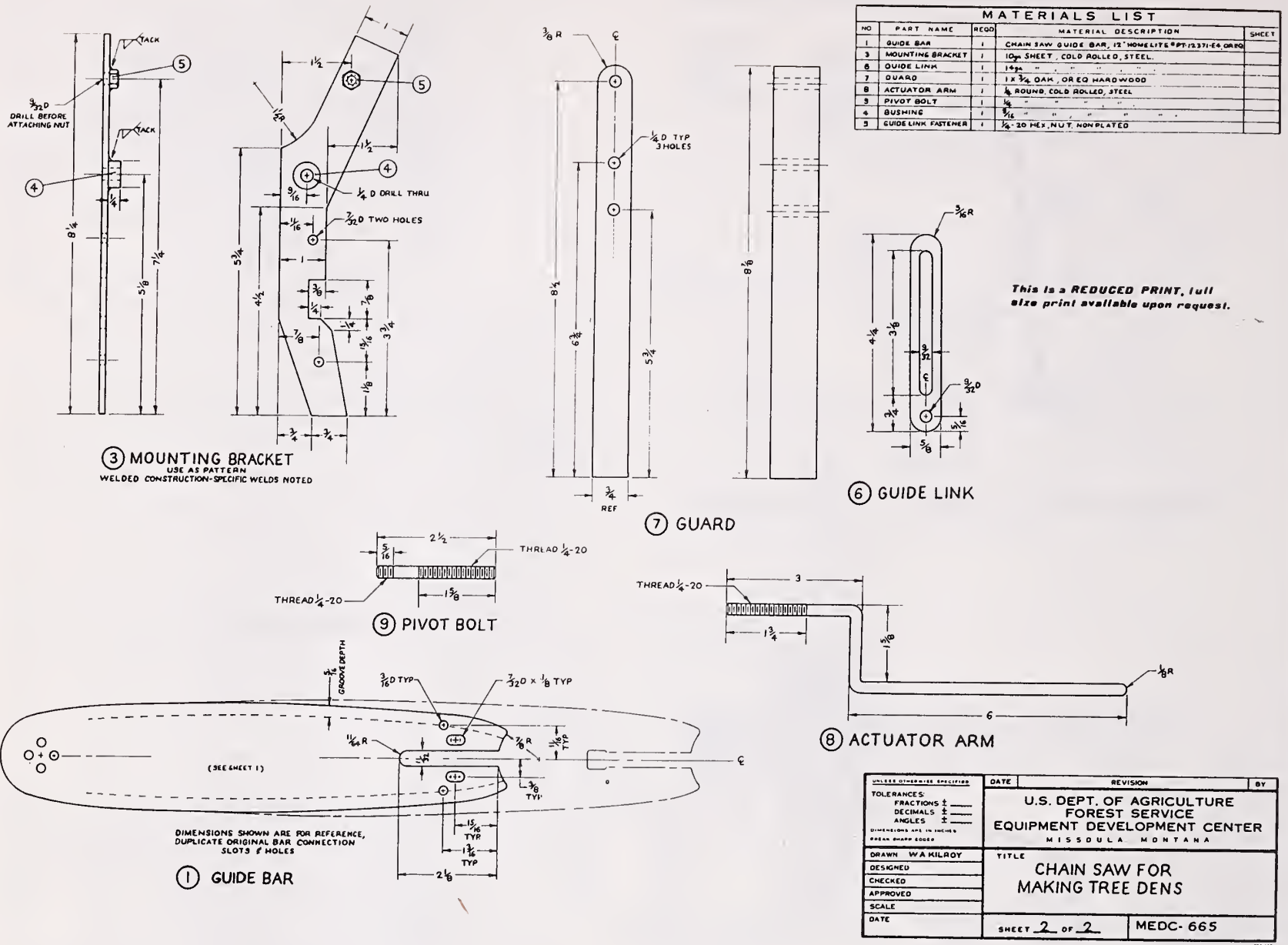

Figure 3B. Modifications to chain saws that are used in constucting cavities: Drawing 2 of 2.

Europe to attract insectivorous birds for pest control is well known (Yoakum et al. 1980). Smith (1975) suggested that nest boxes could raise the density of white-footed mice (*Peromyscus leucopus*) to aid in the control of gypsy moths in young, even-aged hardwood forests. Tom Grubb's work has potential for integrated pest management in U.S. forests. Joe Witt<sup>10</sup> is evaluating the use of nest boxes for increasing populations of northern flying squirrels to increase prey availability in areas managed for spotted owls (*Strix occidentalis*). As with any management effort, installation of artificial structures or acceleration of cavity-forming processes should be subject to cost-benefit

analysis. Costs of artificially providing shelter for cavity-using wildlife also can be used in cost-benefit analyses of other resource management activities.

ACKNOWLEDGMENTS

Most of the work reported in detail was done by or in cooperation with the Wildlife Habitat Management in the Central Appalachians research work unit, Northeastern Forest Experiment Station, Morgantown, W.Va. F. L. Pogge was forestry technician, H. R. Sanderson was research wildlife biologist, and Eli Milodragovich, T. Grubb, A. Peterson, and V. Flyger were cooperators. E. S. Nenko provided technical assistance in the den routing study. Del Thompson, Pacific Northwest Forest and Range Experiment Station prepared the figures.

<sup>10</sup>Witt, J. W. 1983. Trapping northern flying squirrels. Paper presented at the annual meeting of the Oregon Chapter of the Wildlife Society, Sun River, Oregon, February 23-25, 1983. Roseburg District, USDI, Bureau of Land Management, Roseburg, Oregon.

LITERATURE CITED

- Alerstam, Thomas, and Goran Hogstedt. 1981. Evolution of hole-nesting in birds. *Ornis Scandinavica* 12:188-193.
- Berry, Larry A., Edwin D. Michael, and H. Reed Sanderson. 1978. Effect of population density on captive gray squirrels. *Transactions of the Northeast Section of the Wildlife Society* 35:53-59.
- Bull, Evelyn L., Arthur D. Partridge, and Wayne G. Williams. 1981. Creating snags with explosives. USDA Forest Service Research Note PNW-393, 4 P. Pacific Northwest Forest and Range Experiment Station, Portland, Oreg.
- Burt, Benjamin P. 1979. Nesting boxes and platforms for birds. *Sialia* 1:150-163.
- Carey, Andrew B., and H. Reed Sanderson. 1981. Routing to accelerate tree-cavity formation. *The Wildlife Society Bulletin* 9(1):14-21.
- Conner, Richard N. 1978. Snag management for cavity nesting birds. p. 120-128. *In* Proceedings of the workshop: Management of southern forests for nongame birds. [Atlanta, GA; January 24-26, 1978]. USDA Forest Service General Technical Report SE-14, 176 p. Southeastern Forest Experiment Station, Asheville, N.C.
- Conner, Richard N., James G. Dickson, and Brian A. Locke. 1981. Herbicide-killed trees infected by fungi: potential cavity sites for woodpeckers. *The Wildlife Society Bulletin* 9(4):308-310.
- Gano, Robert D., Jr, and James A. Mosher. 1983. Artificial cavity construction--an alternative to nest boxes. *The Wildlife Society Bulletin* 11(1):74-76.
- Gary, Howard L., and Meredith J. Morris. 1980. Constructing wooden boxes for cavity-nesting birds. USDA Forest Service Research Note RM-381, 7 p. Rocky Mountain Forest and Range Experiment Station, Ft. Collins, Colo.
- Grubb, Thomas C., Jr. 1982. Downy woodpecker sexes select different cavity sites: an experiment using artificial snags. *The Wilson Bulletin* 94(4):577-581.
- Hardin, Kimberly I., and Keith E. Evans. 1977. Cavity nesting bird habitat in the oak-hickory forest...a review. USDA Forest Service General Technical Report NC-30, 23 p. North Central Forest Experiment Station, St. Paul, Minn.
- McComb, William C., and Robert E. Noble. 1981a. Microclimate of nest boxes and natural cavities in bottomland hardwoods. *Journal of Wildlife Management* 45(1):284-289.
- McComb, William C., and Robert E. Noble. 1981b. Nest-box and natural-cavity use in three mid-south forest habitats. *Journal of Wildlife Management* 45(1):93-101.
- McComb, William C., and Robert E. Noble. 1981c. Herpetofaunal use of natural tree cavities and nest boxes. *The Wildlife Society Bulletin* 9(4):261-267.
- McComb, William C., and Robert E. Noble. 1982. Invertebrate use of natural tree cavities and vertebrate nest boxes. *American Midland Naturalist* 107(1):163-171.
- McComb, William C., and Robert L. Ramsey. 1983. Characteristics and cavity-nesting bird use of picloram-created snags in the central Appalachians. *Southern Journal of Applied Forestry* 7(1):34-37.
- Nixon, Charles M., and R. W. Donohoe. 1979. Squirrel nest boxes--are they effective in young stands? *The Wildlife Society Bulletin* 7(4):283-284.
- Pinkowski, Benedict C. 1977. Blowfly parasitism of eastern bluebirds in natural and artificial nest sites. *Journal of Wildlife Management* 41(2):272-276.
- Sanderson, H. Reed. 1975. Den-tree management for gray squirrels. *The Wildlife Society Bulletin* 3(3):125-131.
- Sanderson, H. Reed, and Larry A. Berry. 1972. A 2-acre enclosure for tree squirrel research. p. 298-300. *In* Proceedings of the 26th Annual Conference of the Southeastern Association of Game and Fish Commissioners, 1972.
- Scott, Virgil E., Jill A. Whelan, and Peggy L. Svoboda. 1980. Cavity-nesting birds and forest management. p. 311-34. *In* Workshop proceedings: Management of western forests and grasslands for nongame birds. [Salt Lake City, Utah; February 11-14, 1980]. USDA Forest Service General Technical Report INT-86, 535 p. Intermountain Forest Range Experiment Station, Ogden, Utah.
- Slagsvold, Tore. 1982. Clutch size variation in passerine birds: the nest predation hypothesis. *Oecologia* 54:159-169.
- Smith, Harvey R. 1975. Management of *Peromyscus leucopus* as part of an integrated program to control the gypsy moth. *Transactions of the Northeastern Fish and Wildlife Conference* 32:111-129.
- Yoakum, Jim, William P. Dasmann, H. Reed Sanderson, Charles M. Nixon, and Hewlette S. Crawford. 1980. Habitat improvement techniques. p. 329-403. *In* Sanford D. Schemnitz, editor. *Wildlife management techniques manual*. Fourth Edition: revised. 686 p. The Wildlife Society, Washington, D. C.



# Habitat Selection Related to Resource Availability Among Cavity-Nesting Birds<sup>1</sup>

Timothy Brush<sup>2</sup>, Bertin W. Anderson, and Robert D. Ohmart<sup>3</sup>

---

Abstract.--Variation in snag species and abundance appeared to explain most of the habitat selection patterns observed in five cavity-nesting riparian species over a three-year period. All species except Ash-throated Flycatchers were most common in areas with cottonwood or willow snags, which have relatively soft wood and are preferred nest sites. Classification of habitats on the basis of nest-site characteristics was useful and should be considered in other habitat selection studies.

---

## INTRODUCTION

Why do animals occur where they do and what causes them to select certain habitats? Interest in habitat selection was stimulated by the reviews of Hilden (1965) and Lack (1954, 1966). Krebs (1970) and Kluijver (1951) concluded that birds selected optimal habitats on the basis of resource abundance and breeding success. Others have concentrated on the psychological basis of habitat selection (Klopfer 1963, Wecker 1963). The experimental approach is desirable but not always possible, due to the limitations of the laboratory environment.

Availability of nest sites is thought to be the main determinant of habitat selection in cavity-nesting birds (von Haartman 1957). Nest-box studies have shown that distribution and abundance of secondary cavity-nesting birds are greatly influenced by nest site availability (Lack 1954, 1966; von Haartman 1957). This is especially true in managed or successional habitats that have high resource levels but otherwise lack nest sites (Pinkowski 1977).

Primary cavity-nesters (families Capitonidae, Picidae, Paridae, and Sittidae) depend greatly on availability of nest sites. For example, Red-cockaded Woodpeckers (*Picoides borealis*) occur only in areas containing live pine (*Pinus* spp.) trees infected with "red heart" fungus (*Fomes pini*), in which they are able to excavate nest

holes (Jackson 1977). Yeager (1955) showed an increase in woodpeckers concurrent with an increase in number of snags (dead trees). This could be due to increased nest sites and foraging substrates, as woodpeckers frequently forage on snags (Mannan et al. 1980).

Anderson and Ohmart (1978) showed a correlation between densities of snags and densities of cavity-nesting birds and suggested that snag availability limited cavity-nesting populations in southwestern riparian situations. They discussed snags in terms of abundance only. We suggest that snag species are also important in riparian habitats and discuss here the value of cottonwood (*Populus fremontii*) and willow (*Salix gooddingii*) snags in various riparian habitats.

Given that snags are an important component of the habitat for riparian cavity-nesters, we attempt to answer the following question: Does variation in snag species explain the distribution of cavity-nesting species in the lower Colorado River valley? In answering this question we propose a habitat classification based on snags and not on plant community type. Our classification is designed to minimize the effects of food resource variability on bird density. We also discuss seasonal fluctuations in bird densities and habitat selection. For woodpeckers, we discuss the relationship between morphological characteristics, excavating ability, and habitat selection.

## METHODS

Transects varying in length from 600 to 1650 m were established in relatively homogeneous stands of riparian vegetation. The sampled area extended laterally 125 m from the transect on both sides. For the original study (Anderson and Ohmart 1977a), each habitat type was sampled in approximate proportion to its occurrence in the lower Colorado

---

<sup>1</sup>Paper presented at the snag habitat management symposium. [Flagstaff, AZ, June 7-9, 1983].

<sup>2</sup>Ph.D. Candidate, Department of Biological Sciences, Rutgers University, Piscataway, NJ.

<sup>3</sup>Faculty Research Associate and Associate Director, respectively, The Center for Environmental Studies, Arizona State University, Tempe, AZ.

River valley. For the purposes of this study, transects were classified into groups, or snag habitats, based on predominant snag species present.

Estimates of bird densities in each study site were obtained using the Emlen (1971) line-transect technique (modified by Anderson et al. 1977). Each study site was censused three times per month. We calculated mean densities over a three-month period or season, involving nine censuses per study site and a minimum of 30 censuses per snag habitat. Results presented are for winter (December-February) and summer (May-July), 1977-1979. This number of censuses was determined to be adequate for reliable density estimates (Anderson and Ohmart 1977b, Engel-Wilson et al. 1981) in the area studied.

#### Snag Counts

A snag count was conducted on all study sites. The count area extended laterally 15 m from the transect line on both sides. All trees  $\geq 14$  cm in diameter with 50-100% dead canopy were counted and converted to snags per 40 ha.

Transects were grouped according to species of snags in the following manner: as cottonwood, if cottonwood snags were present (regardless of other snag species present); as willow, if willow snags were present in the absence of cottonwood; as honey mesquite (*Prosopis glandulosa*) or screwbean mesquite (*P. pubescens*) if present in the absence of cottonwood or willow snags; and as snagless if no snags were present. Cottonwoods and willows were considered to be softwood species compared to hardwood mesquite species (Hepting 1971). More than one vegetation habitat type was usually present in each snag habitat type (table 1).

#### Foraging Behavior

Foraging behavior of woodpeckers was recorded in all study sites to better understand the foraging niche of each species. We were primarily interested in two parameters: (1) use of snags as a foraging substrate; and (2) foraging method (pecking, probing, gleaning, or hawking).

#### Snag Use

Several study areas were chosen to examine snag preferences in different plant community types. There was one study area of 20 ha each in cottonwood-willow and honey mesquite vegetation types. There was a 20-ha and an 80-ha area in screwbean mesquite habitat. Ten areas totalling 93 ha were examined in salt cedar (*Tamarix chinensis*) habitats.

In all study areas detailed observations were made of snag availability and usage by cavity-nesters. A snag was considered to be "used" if one or more completed woodpecker cavities were present. Additionally we searched for active nests or roosts throughout riparian habitats in the lower Colorado River valley.

#### RESULTS

#### Snag Density

Snag densities varied from 121 screwbean mesquite snags per 40 ha to 215 cottonwood snags per 40 ha (table 2). All snag habitats appeared to be homogeneous in species composition, with the exception of cottonwood, which had relatively high numbers of willow (104/40 ha) and screwbean mesquite (109/40 ha) snags. Variances in snag

Table 1.--Relationship between vegetation habitat and snag availability in the lower Colorado River valley.

Vegetation habitat type*	Snag habitat type				
	Cottonwood	Willow	Honey mesquite	Screwbean mesquite	Snagless
Cottonwood-willow	5**	10	-	-	5
Honey mesquite	-	-	15	-	5
Screwbean mesquite	4	4	-	5	7
Salt cedar (Tamarisk)	-	1	2	-	9
TOTAL	9	15	17	5	26

\* From Anderson et al. 1977  
 \*\* Number of transects



Table 2.--Snag density in the lower Colorado River valley.  
Mean  $\pm$ SE, N/40 ha.

	Snag habitat types				
	Cottonwood	Willow	Honey mesquite	Screwbean mesquite	Snagless
Number of transects	9	15	17	5	26
<u>Snag species</u>					
Cottonwood	215 $\pm$ 22	-	-	-	-
Willow	104 $\pm$ 16	184 $\pm$ 14	-	-	-
Honey mesquite	-	-	122 $\pm$ 4	-	-
Screwbean mesquite	109 $\pm$ 23	12 $\pm$ 3	2 $\pm$ 0.3	130 $\pm$ 30	-
TOTAL DENSITY	428 $\pm$ 32*	196 $\pm$ 16	123 $\pm$ 4	130 $\pm$ 30	0 $\pm$ 0

\* Cottonwood habitat had significantly more snags when compared to honey mesquite alone, screwbean mesquite alone, and all other habitats combined (Dunn's Multiple Comparison values  $>2.69$ ,  $P<0.05$ ).

densities were high and unequal; nonparametric analysis revealed that there were more snags in cottonwood habitat than in all other areas combined and more than in honey mesquite or screwbean mesquite habitats alone (Dunn's Multiple Comparison [DMC]; values of 2.99, 2.70, and 2.80, respectively;  $P<0.05$  in all cases; Dunn 1964). All other comparisons were not significant.

#### Seasonal Variation in Bird Densities

Brown-crested Flycatchers (*Myiarchus tyrannulus*) and Ash-throated Flycatchers (*M. cinerascens*) were present in summer only (fig. 1). Individual Ash-throated Flycatchers may be found in winter widely scattered in desert washes and honey mesquite habitats. Northern Flickers (*Colaptes auratus*) were more abundant in winter than in summer, whereas Gila Woodpeckers and Ladder-backed Woodpeckers appeared to be more abundant in summer (fig. 1).

#### Annual Variation in Bird Densities

There were no significant differences among years in numbers of any of the woodpeckers in summer nor in the Gila Woodpecker (*Melanerpes uropygialis*) in winter (fig. 1, table 3). Ladder-backed Woodpecker (*Picoides scalaris*) numbers were lower in winter 1976-1977 than in 1977-1978 (Dunn's Multiple Comparison,  $Z = 2.53$ ,  $P<0.05$ ). Northern Flickers had highest densities in winter 1978-1979, intermediate in winter 1976-1977, and lowest in winter 1977-1978 (all differences significant, DMC = 2.81 to 7.91,  $P<0.05$  in all cases). Brown-crested Flycatcher densities did

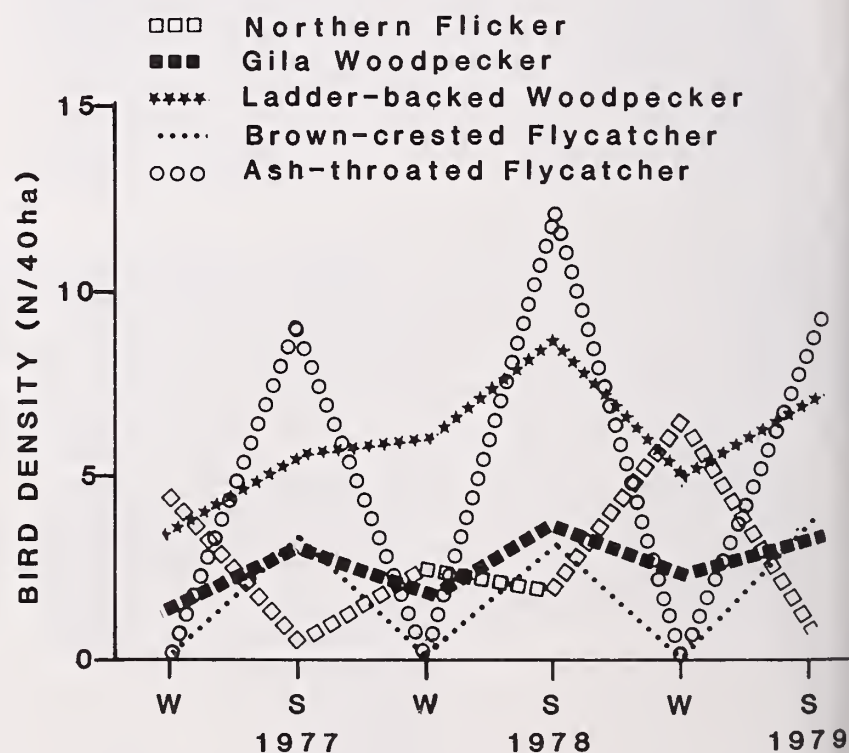

Figure 1.--Seasonal fluctuations in population density of cavity-nesting birds, lower Colorado River valley. Numbers presented are means, all standard errors  $<0.2$ .

Table 3.--Yearly fluctuations of populations of cavity-nesting birds, lower Colorado River valley. -- indicates not present, > indicates population was significantly higher in one year compared to another, ns = nonsignificant. Based on Dunn's Multiple Comparison Test, values >2.69 for significance at P<0.05.

Species	Winter	Summer
Northern Flicker	1978-79>1976-77>1977-78	ns
Gila Woodpecker	ns	ns
Ladder-backed Woodpecker	1977-78>1976-77	ns
Brown-crested Flycatcher	--	ns
Ash-throated Flycatcher	--	1978>1977

not vary significantly; Ash-throated Flycatchers were more abundant in summer 1978 than in summer 1977 (DMC = 2.70, P<0.05).

#### Habitat Preference

Overall, in 18 of 24 comparisons among snag habitat types (1 per species per season, Dunn's Multiple Comparison, P<0.05), cavity-nesters proved to be more abundant in cottonwood than in other snag habitats (figs. 2-9, tables 4 and 5). In two of the remaining six cases, there was no habitat preference (Gila Woodpecker in winter 1977-78 and in summer 1978). The other four cases are Ladder-backed Woodpecker in winter 1978-1979, and Ash-throated Flycatcher in summer 1977, 1978, and 1979; these are discussed below.

#### Winter

Cottonwoods were preferred habitat in seven of nine comparisons (table 4). Northern Flickers showed a primary preference for cottonwood and a secondary preference for willow in 1976-1977 (fig. 3). There appeared to be a weak, but not statistically significant, preference for willow in the other two winters. Gila Woodpeckers also showed a preference for cottonwood in 1976-1977 and 1978-1979 winters. The large amount of within-habitat variation in 1977-1978 appeared to cause lack of habitat preference within that period, although the mean density of Gila Woodpeckers in cottonwood habitat was higher than in other habitats (fig. 5). Gila Woodpeckers were uncommon in mesquite and snagless habitats ( $N \leq 2/40$  ha) in all winters. Ladder-backed Woodpeckers preferred cottonwood habitat in the first two winters but not in the winter of 1978-1979 when they were abundant in other habitats. They showed a clear preference for honey and screwbean mesquite habitat over snagless habitat in 1978-1979 (fig. 7).

#### Summer

In 11 of 15 comparisons, cottonwood was preferred habitat (table 5). However, there was a secondary preference for willow (seven of the above 11 cases) by most species. Northern Flickers preferred cottonwood all three summers and showed a secondary

preference for willow in 1977 and 1979 (fig. 2). This species was seldom seen in mesquite and snagless habitats in all years and was rarely seen in willow in 1979. Gila Woodpeckers showed a different pattern each year, preferring cottonwood primarily and willow secondarily in 1977, showed no preference in 1978, and preferred cottonwood only in 1979. There appeared to be larger population fluctuations in this species than in other species of woodpeckers; however, Gila Woodpeckers were rarely seen in snagless and screwbean mesquite habitats in all three summers. Distribution appeared to be most even across habitats in 1978 (fig. 4). Ladder-backed Woodpeckers preferred cottonwood over other habitats all three years (fig. 6). In 1978, there was a secondary preference for willow; in the other summers, mesquite habitats were preferred over snagless habitats. Brown-crested Flycatchers showed a primary preference for cottonwood and a secondary preference for willow in each summer (fig. 8). This species was almost totally absent from other habitats. Ash-throated Flycatchers showed a different pattern: honey mesquite and willow, and screwbean mesquite in 1977, were preferred over remaining habitats. Ash-throated Flycatchers were present in all habitats, including snagless habitats (fig. 9).

There was no clear-cut relationship between population levels and variation in habitat selection. Secondary cavity-nesters (flycatchers) appeared to be more consistent in habitat selection than were primary cavity-nesters (woodpeckers).

#### Foraging Behavior of Woodpeckers

Analysis of foraging behavior revealed some differences, despite great disparity in sample sizes among species.

#### Foraging Method

There were significant differences in foraging methods among woodpeckers (fig. 10,  $\chi^2 = 1307.5$ ,  $df = 6$ , P<0.005). Ladder-backed Woodpeckers foraged by pecking more than did Gila Woodpeckers or Northern Flickers. Gila Woodpeckers probed and gleaned more often than Ladder-backed Woodpeckers. There was a higher proportion of observations in



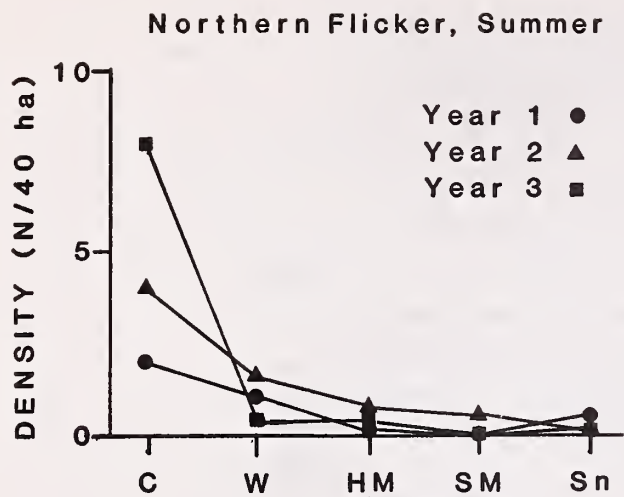

Figure 2.--Habitat selection by Northern Flickers in summer, lower Colorado River valley. C = cottonwood, W = willow, HM = honey mesquite, SM = screwbean mesquite, Sn = snagless. Year 1 = 1977, Year 2 = 1978, Year 3 = 1979.

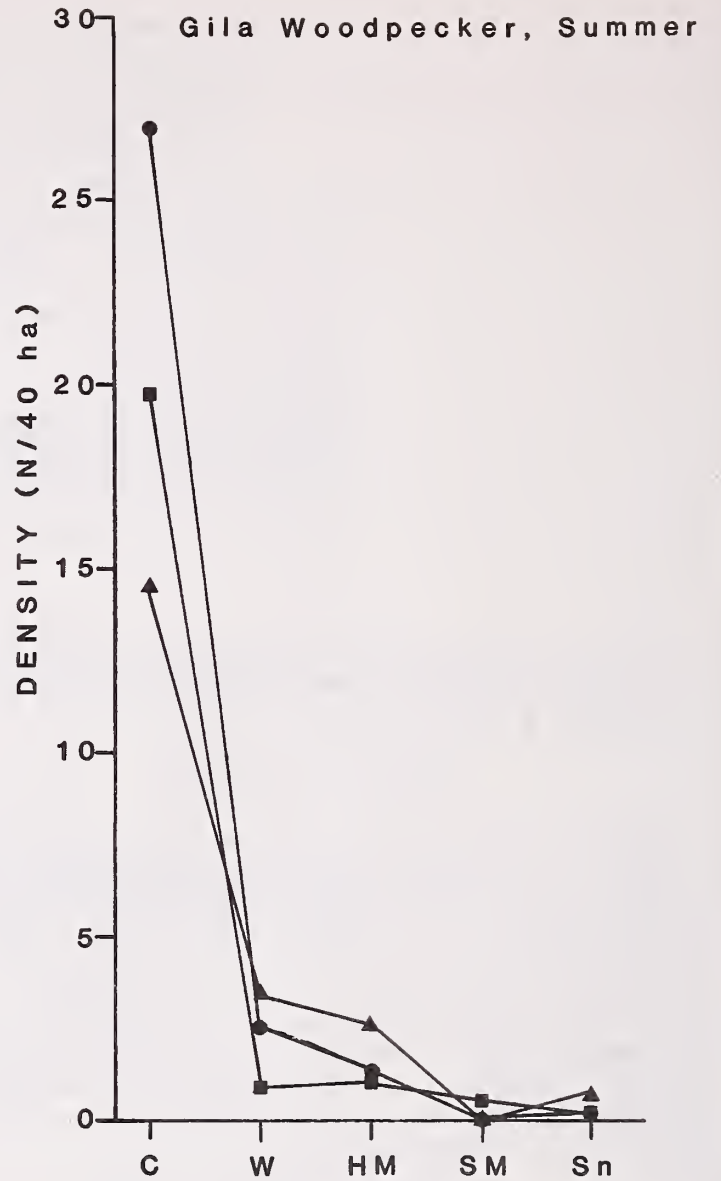

Figure 4.--Habitat selection by Gila Woodpeckers in summer, lower Colorado River valley. Years, abbreviations, and symbols as in figure 2.

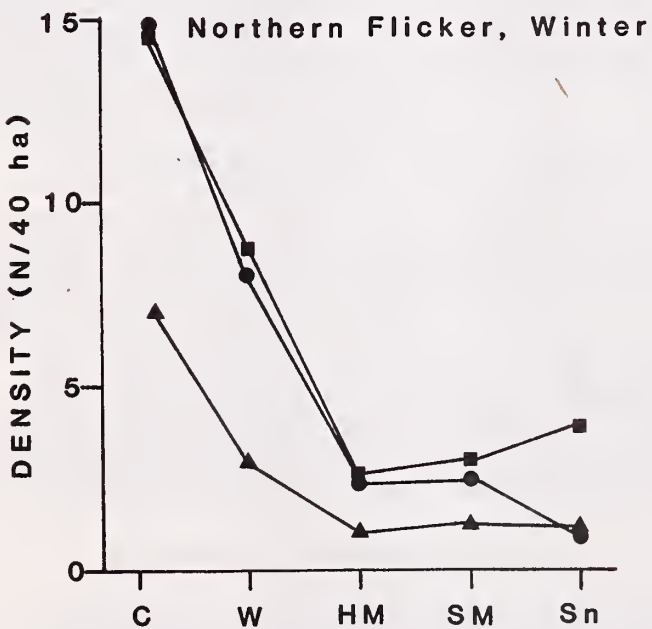

Figure 3.--Habitat selection by Northern Flickers in winter, lower Colorado River valley. Year 1 = 1976-1977, Year 2 = 1977-1978, Year 3 = 1978-1979. Abbreviations and symbols as in figure 2.

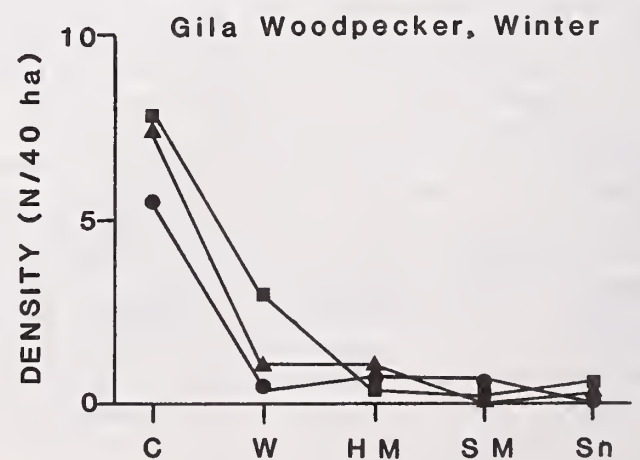

Figure 5.--Habitat selection by Gila Woodpeckers in winter, lower Colorado River valley. Years as in figure 3 and abbreviations and symbols as in figure 2.

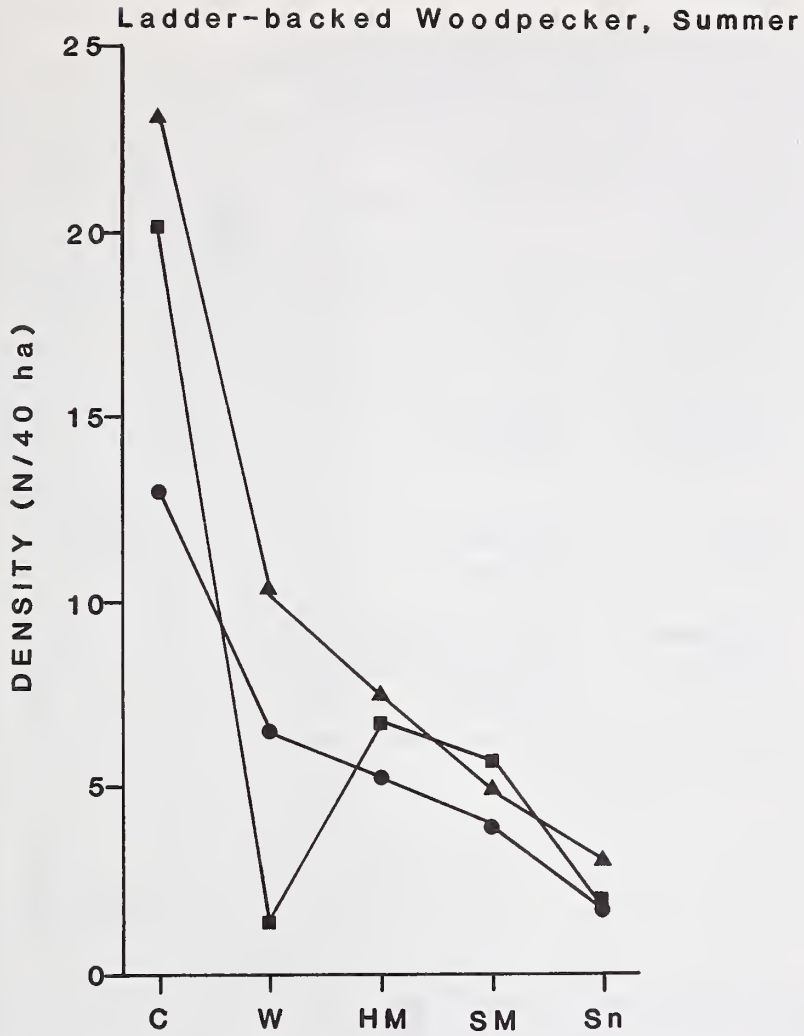

Figure 6.--Habitat selection by Ladder-backed Woodpeckers in summer, lower Colorado River valley. Years, abbreviations, and symbols as in figure 2.

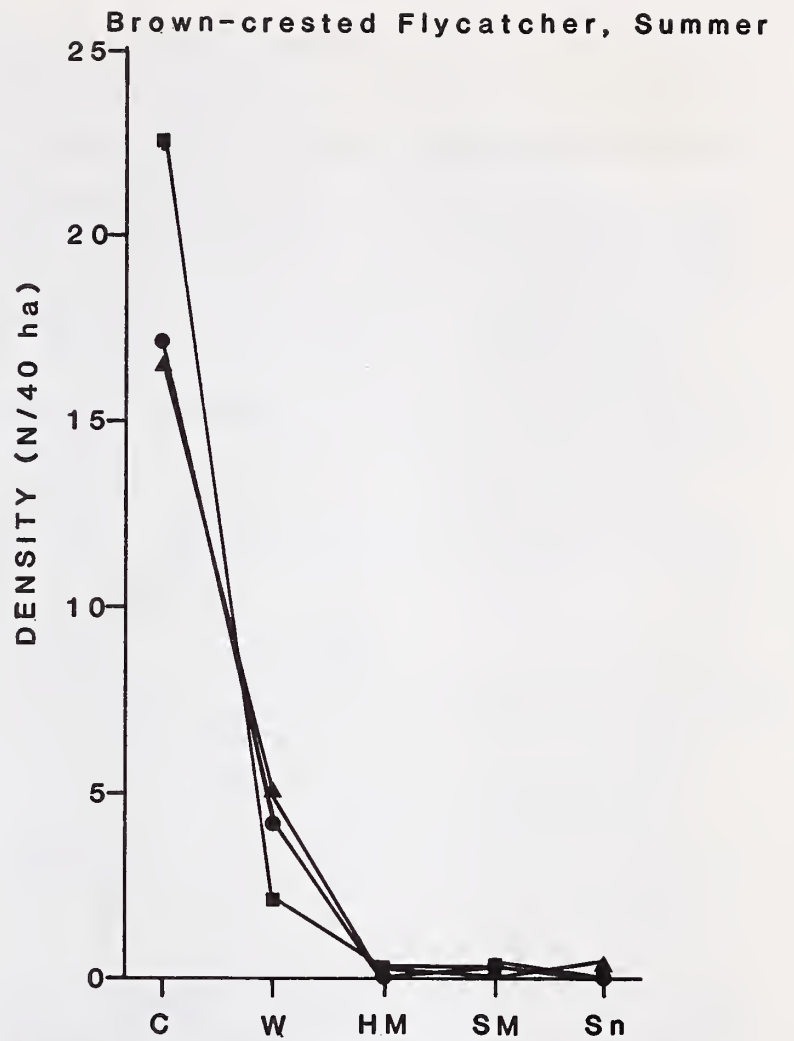

Figure 8.--Habitat selection by Brown-crested Flycatchers in summer, lower Colorado River valley. Years, abbreviations, and symbols as in figure 2.

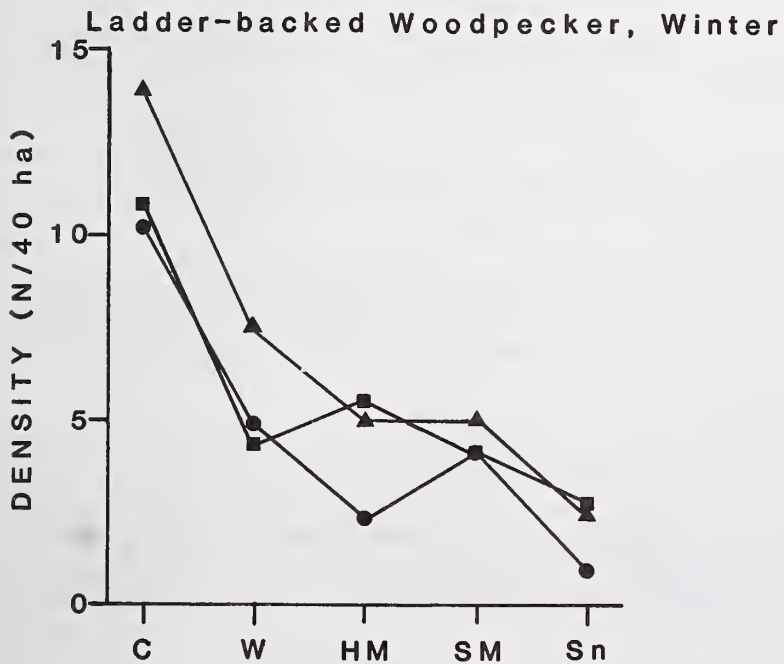

Figure 7.--Habitat selection by Ladder-backed Woodpeckers in winter, lower Colorado River valley. Years as in figure 3 and abbreviations and symbols as in figure 2.

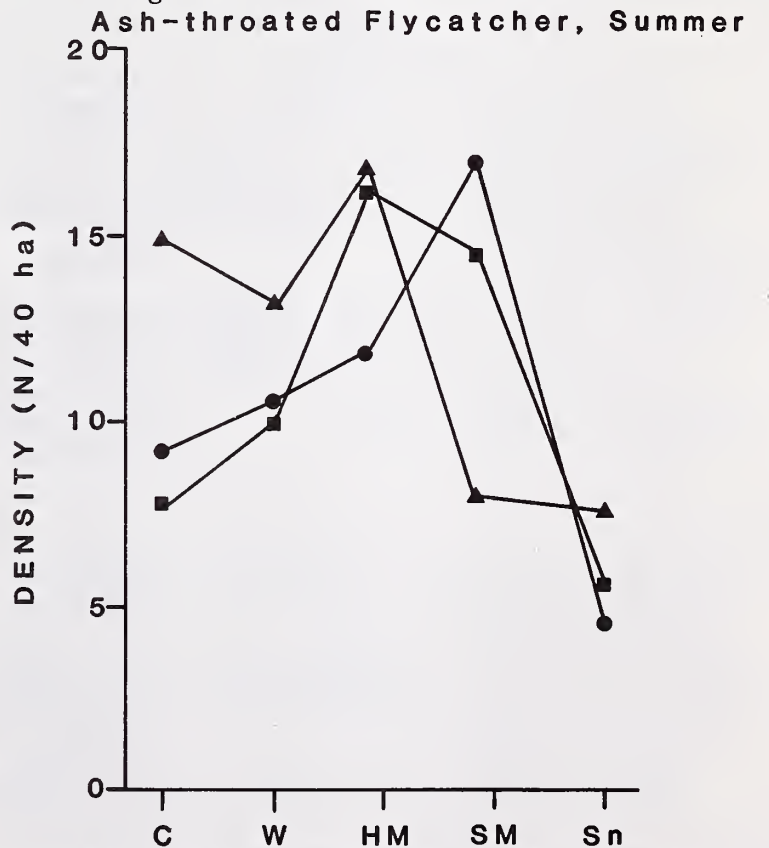

Figure 9.--Habitat selection by Ash-throated Flycatchers in summer, lower Colorado River valley. Years, abbreviations, and symbols as in figure 2.



Table 4.--Habitat selection of three cavity-nesting birds in winter in the lower Colorado River valley. Habitats are listed in order of preference. Snag habitats include: cottonwood, willow, honey mesquite, screwbean mesquite, and snagless. "Others" indicates habitats not previously listed. Kruskal-Wallis nonparametric test used in all cases involved  $P < 0.05$ .

Bird species	1976-1977	1977-1978	1978-1979
Northern Flicker	Cottonwood Willow Others	Cottonwood Others	Cottonwood Others
Gila Woodpecker	Cottonwood Others	None	Cottonwood Others
Ladder-backed Woodpecker	Cottonwood Others	Cottonwood Others	Honey mesquite and screwbean mesquite Snagless

Table 5.--Habitat selection of cavity-nesting birds in summer in the lower Colorado River valley. Habitats as in table 4.

Bird species	1977	1978	1979
Northern Flicker	Cottonwood Willow Others	Cottonwood Others	Cottonwood Willow Others
Gila Woodpecker	Cottonwood Willow Others	None	Cottonwood Others
Ladder-backed Woodpecker	Cottonwood Others Honey mesquite Snagless	Cottonwood Willow Others	Cottonwood Others Honey mesquite and screwbean mesquite Snagless
Brown-crested Flycatcher	Cottonwood Willow Others	Cottonwood Willow Others	Cottonwood Willow Others
Ash-throated Flycatcher	Honey mesquite, screwbean mesquite, and willow Cottonwood and snagless Others Snagless	Honey mesquite and screwbean mesquite Snagless Honey mesquite and willow Others	Honey mesquite and willow Others Others Snagless

## FORAGING BEHAVIOR

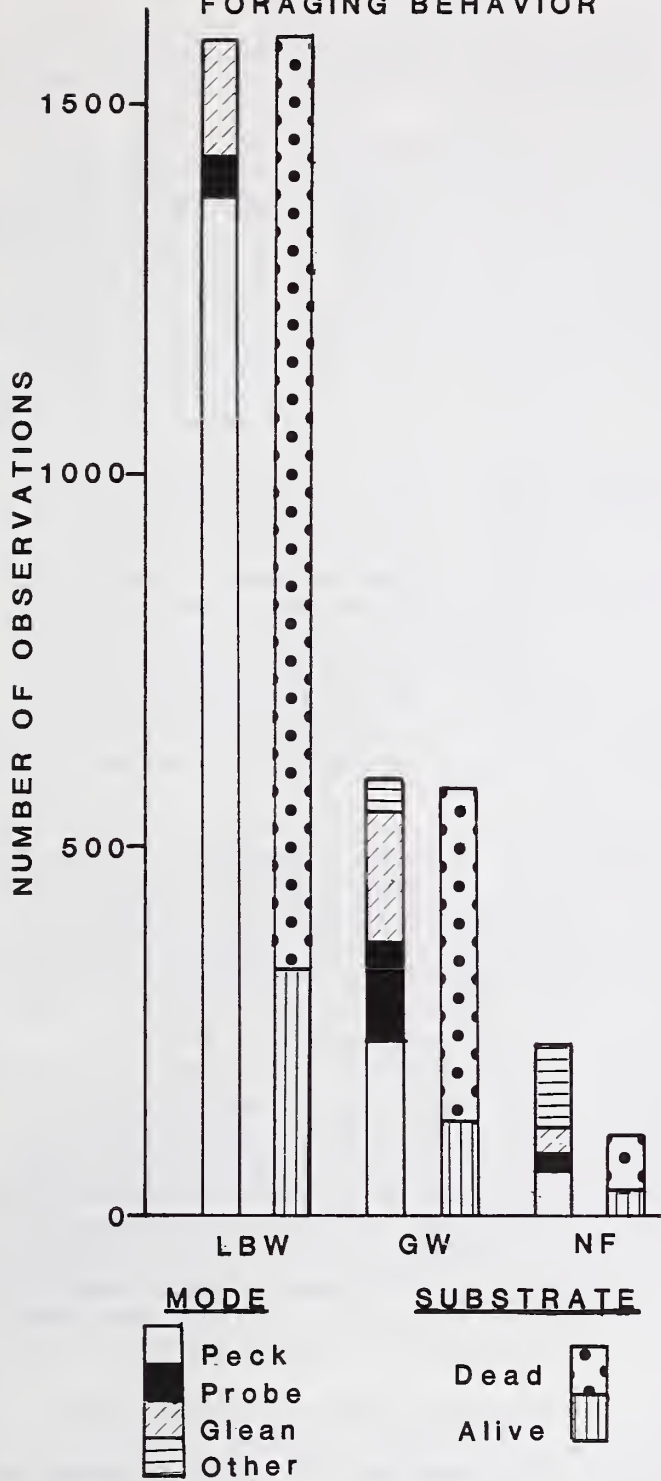

Figure 10.--Foraging behavior of woodpeckers - mode and substrate. LBW = Ladder-backed Woodpecker, GW = Gila Woodpecker, NF = Northern Flicker.

the "other" column for Gila Woodpeckers and Northern Flickers than for Ladder-backed Woodpeckers. Most of the observations in this category represent frugivory (eating mistletoe, *Phoradendron californicum*, berries) by the Gila Woodpecker and ground-foraging by the Northern Flicker.

### Foraging Substrate

There were no significant differences among woodpeckers in the proportion of foraging time spent on dead limbs or snags (fig. 10,  $\chi^2 = 0.43$ ,  $df = 2$ ,  $P > 0.5$ ).

### Comparison of Snag Usage in Different Habitats

Cottonwood and willow snags were used to the same extent for nesting on the cottonwood-willow study area ( $\chi^2 = 1.13$ ,  $df = 1$ ,  $P > 0.25$ ). Neither snag species had greater than 20% use (fig. 11). Use of cottonwood and willow snags in the cottonwood-willow study area was lower than use of these species in mesquite study areas (cottonwood:  $\chi^2 = 13.4$ ,  $df = 1$ ,  $P < 0.005$ ; willow:  $\chi^2 = 24.3$ ,  $df = 1$ ,  $P < 0.005$ ). Cottonwood and willow combined were used by cavity-nesters to a greater extent than was honey mesquite on the honey mesquite study area ( $\chi^2 = 6.8$ ,  $df = 1$ ,  $P < 0.025$ ) or screwbean mesquite on the screwbean mesquite study area ( $\chi^2 = 12.8$ ,  $df = 1$ ,  $P < 0.005$ ).

There were no areas containing both honey mesquite and screwbean mesquite snags; however, use of honey mesquite was significantly greater than use of screwbean mesquite ( $\chi^2 = 5.5$ ,  $df = 1$ ,  $P < 0.025$ , fig. 11). Tamarisk (*Tamarix chinensis* and *T. aphylla*) snags were not used at all (45 *T. chinensis* and 11 *T. aphylla* snags on 10 study areas). Ten of 22 telephone poles along a dirt road within a honey mesquite habitat contained cavities. In habitats having both hardwood (mesquite) and softwood (cottonwood, willow, and saguaro, *Carnegiea gigantea*) snags, Ladder-backed Woodpeckers used hardwood snags for cavity excavation to a significantly greater extent than did Northern Flickers and Gila Woodpeckers ( $\chi^2 = 24.7$ ,  $df = 2$ ,  $P < 0.001$ , table 6).

### DISCUSSION

Densities of cavity-nesting species showed a fluctuating seasonal pattern. Densities were higher in the breeding season (spring and summer) than in winter. The Northern Flicker was an exception to this pattern in that there was an influx of *C. a. cafer*, which obscured any seasonal pattern that might have been shown by the resident *C. a. chrysoides* (Phillips et al. 1964). Among nonresident cavity-nesters, Brown-crested Flycatchers winter from Mexico south into South America, whereas Ash-throated Flycatchers winter in most of Mexico and in northern Central America (Lanyon 1960, 1961).

Significant between-year variations in densities of cavity-nesters were limited and can probably be explained on the basis of the winter's severity. The coldest winter during the study period was 1978-1979, when temperatures below freezing were common. Winter 1976-1977 was intermediate, whereas winter 1977-1978 was exceptionally warm and had high rainfall (Meents et al. 1981). Northern Flicker abundance was proportional to winter severity, probably due to a greater influx of migrant flickers from other areas. Trends in other woodpecker populations were similar, with greatest reductions in numbers occurring in the harsh winter, although this difference was not significant.



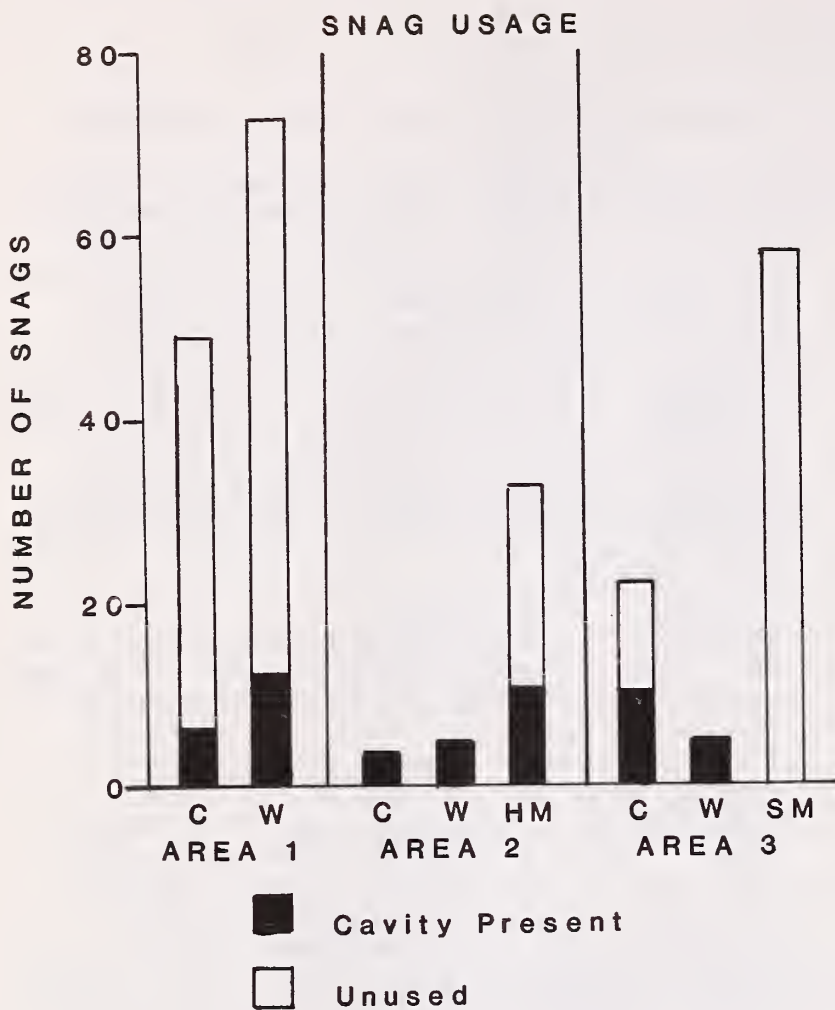

Figure 11.--Snag usage by cavity-nesting birds in different vegetation habitats, lower Colorado River valley. Abbreviations as in figure 2. Area 1 = cottonwood-willow vegetation, Area 2 = honey mesquite vegetation, Area 3 = screwbean mesquite vegetation.

Overall preference for cottonwood snag habitat was highly significant; preference for willow was only sometimes significant. This trend can be explained by a combination of snag use (fig. 11) and snag abundance data (table 2). In cottonwood, the greater abundance and diversity of snag species and presence of softwood species appears to explain why four of five cavity-nesting bird species preferred this habitat. Presumably, many of these snags provided potential nest sites. In willow habitat, the presence of willow snags, another softwood, probably explains the secondary preference for this habitat. Availability of roost holes in winter may be as important as nest sites in summer for woodpeckers (Baker 1971). Ladder-backed Woodpeckers appear to have been less dependent on softwood trees than were Gila Woodpeckers or Northern Flickers; hence there was a weak preference by Ladder-backed Woodpeckers for mesquite habitat over snagless habitat. Gila Woodpeckers and Northern Flickers were almost absent from mesquite in summer. The fact that Northern Flickers were present in mesquite areas in winter may be due to use of noncavity roost sites for this species (Bent 1939).

Morphological adaptations in woodpecker species may explain both habitat preference and foraging method. Ladder-backed Woodpeckers, because of structural modifications of skull, vertebrae, and ribs, are best adapted for excavating hardwood (Kirby 1980). This species feeds primarily by pecking, and it can excavate nest sites in hard-wooded mesquite trees. Northern Flickers and Gila Woodpeckers are less well adapted for excavating nest holes in hardwoods. This may account for their greater use of nonexcavating foraging modes, their dependence on softwood snags for cavity excavation, and their less frequent occurrence in mesquite habitats. The occurrence of Gila Woodpeckers and Northern Flickers seems to be dependent on nest site availability, since they seem more adaptable in foraging methods.

The species most restricted to cottonwood and willow snag habitats was the Brown-crested Flycatcher. This can best be explained by patterns of nest site availability, as this relatively large secondary cavity-nester is dependent on the presence of large cavities for nesting. There appear to be few large natural cavities in any of the habitats in the lower Colorado River valley. Brown-crested Flycatchers have been observed foraging in honey mesquite, screwbean mesquite, and salt cedar habitats surrounding lone cottonwood or willow snags in which woodpecker cavities were present, in five of the transects classified here as cottonwood or willow.

Habitat preference of Ash-throated Flycatchers is more difficult to explain. The abundance of this species does not appear to be positively correlated with any primary or secondary cavity-nesting species. The only similarity in habitat selection to other cavity-nesting bird species is in its avoidance of snagless habitats. Ash-throated Flycatchers appear to be as common in cottonwood snag habitat as primary cavity-nesters, but the

Table 6.--Nest-site selection by woodpeckers in the lower Colorado River valley.

Bird species	Snag type	
	Softwood <sup>a</sup>	Hardwood <sup>b</sup>
Northern Flicker	12 <sup>c</sup>	--
Gila Woodpecker	9	3
Ladder-backed Woodpecker	--	10

<sup>a</sup>Cottonwood, willow, and saguaro.  
<sup>b</sup>Honey mesquite and screwbean mesquite.  
<sup>c</sup>Figures indicate number of active nests or roosts.



much greater abundance of Ash-throated Flycatchers in mesquite and willow snag habitats suggests that this species is not dependent on woodpeckers for nest cavities.

Habitat selection in Ash-throated Flycatchers may be based on vegetational or structural preference. This species shows preference for vegetation of moderate height (3.0-4.5 m; Anderson and Ohmart unpubl. data) and is often found in mesquite habitat (Phillips et al. 1964). The lack of dependence on woodpeckers is shown by its use of natural cavities (Bent 1942, pers. obs.) as well as woodpecker cavities.

There appears to be an inverse relationship between abundance patterns of Brown-crested Flycatchers and Ash-throated Flycatchers in the lower Colorado River valley. This could be attributed to competitive exclusion (Cody 1974), as diets and foraging mode are very similar (Rosenberg et al. 1982). However, nest sites are partitioned on the basis of size in these two species (Brush 1981), and interspecific territoriality away from the nest site has not been observed. Size difference between the species and a superabundant food resource may aid in avoidance of competition. That size is important is supported by anecdotal evidence of interspecific territorial behavior in the limited overlap between Brown-crested Flycatchers and the similar-sized Great Crested Flycatcher, Myiarchus crinitus (Oberholser 1974).

#### ACKNOWLEDGMENTS

We gratefully acknowledge the many field biologists who helped collect the bird data. We thank A. Kurt Webb for the computer printouts, Susan M. Cook and Jane R. Durham for editorial comments, and Cindy D. Zisner for typing the manuscript and preparing the illustrations. This study was funded largely by U.S. Bureau of Reclamation Contract No. 7-07-30-V0009.

#### LITERATURE CITED

- Anderson, B. W., R. W. Engel-Wilson, D. Wells, and R. D. Ohmart. 1977. Ecological study of southwestern riparian habitats: Techniques and data applicability. p. 146-155. In Importance, preservation and management of riparian habitat: A symposium. Proceedings of the symposium [Tucson, AZ, July 9, 1977] USDA Forest Service General Technical Report RM-43, 217 p. Rocky Mountain Forest and Range Experiment Station, Fort Collins, CO.
- Anderson, B. W., and R. D. Ohmart. 1977a. Vegetation structure and bird use in the lower Colorado River valley. p. 23-34. In Importance, preservation and management of riparian habitat: A symposium. Proceedings of the symposium [Tucson, AZ, July 9, 1977] USDA Forest Service General Technical Report RM-43, 217 p. Rocky Mountain Forest and Range Experiment Station, Fort Collins, CO.
- Anderson, B. W., and R. D. Ohmart. 1977b. Climatological and physical characteristics affecting avian population estimates in southwestern riparian communities using transect counts. p. 193-200. In Importance, preservation and management of riparian habitat: A symposium. Proceedings of the symposium [Tucson, AZ, July 9, 1977] USDA Forest Service General Technical Report RM-43, 217 p. Rocky Mountain Forest and Range Experiment Station, Fort Collins, CO.
- Anderson, B. W., and R. D. Ohmart. 1978. Wildlife use and densities. Annual Report to the U.S. Bureau of Reclamation, Boulder City, NV.
- Baker, W. W. 1971. Progress report on life history studies of the Red-cockaded Woodpecker at Tall Timbers Research Station. p. 44-59. In Ecology and management of the Red-cockaded Woodpecker. U.S. Department of Agriculture, Bureau of Sport Fisheries and Wildlife, Washington, D. C.
- Bent, A. C. 1939. Life histories of North American woodpeckers. Smithsonian Institution U.S. National Museum Bulletin No. 174. U.S. Government Printing Office, Washington, D.C.
- Bent, A. C. 1942. Life histories of North American flycatchers, larks, swallows, and their allies. Smithsonian Institution U.S. National Museum Bulletin No. 179. U.S. Government Printing Office, Washington, D.C.
- Brush, T. 1981. Response of secondary cavity-nesting birds to manipulation of nest-site availability. Unpublished Master's thesis. 34 p. Arizona State University, Tempe, AZ.
- Cody, M. L. 1974. Competition and the structure of bird communities. Monographs in Population Biology No. 7, 318 p. Princeton University Press, Princeton, NJ.
- Dunn, O. J. 1964. Multiple comparisons using rank sums. *Technometrics* 6:241-252.
- Emlen, J. T. 1971. Population densities of birds derived from transect counts. *Auk* 88:323-342.
- Engel-Wilson, R. W., A. K. Webb, K. V. Rosenberg, R. D. Ohmart, and B. W. Anderson. 1981. Avian censusing with the strip method: A computer simulation. p. 445-449. In Estimating numbers of terrestrial birds. Proceedings of an international symposium [Asilomar, CA, October 26-31, 1980] *Studies in Avian Biology* No. 6, 630 p. Published by the Cooper Ornithological Society, Allen Press, Lawrence, KS.
- Hepting, G. H. 1971. Diseases of forest and shade trees of the United States. USDA Forest Service Agricultural Handbook No. 386. Washington, D.C.
- Hilden, O. 1965. Habitat selection in birds. *Annales Zoologici Fennici* 2:53-75.



- Jackson, J. A. 1977. Red-cockaded Woodpeckers and pine red heart disease. *Auk* 94:160-163.
- Kirby, V. C. 1980. An adaptive modification in the ribs of woodpeckers and piculets (Picidae). *Auk* 97:521-532.
- Klopfer, P. H. 1963. Behavioral aspects of habitat selection: The role of early experience. *Wilson Bulletin* 75:15-22.
- Kluijver, H. N. 1951. The population ecology of the Great Tit, Parus m. major L. *Ardea* 39:1-135.
- Krebs, J. R. 1970. Territory and breeding density in the Great Tit, (Parus major L.). *Ecology* 52:2-22.
- Lack, D. 1954. The natural regulation of animal numbers. 343 p. Clarendon Press, Oxford, England.
- Lack, D. 1966. Population studies of birds. 341 p. Oxford University Press, Oxford, England.
- Lanyon, W. E. 1960. The middle American populations of the Crested Flycatcher, Myiarchus tyrannulus. *Condor* 62:341-350.
- Lanyon, W. E. 1961. Species limits and distribution of Ash-throated and Nutting flycatchers. *Condor* 63:421-449.
- Mannan, R. W., E. C. Meslow, and H. M. Wight. 1980. Use of snags by birds in Douglas-fir forests, western Oregon. *Journal of Wildlife Management* 44:787-797.
- Meents, J. K., B. W. Anderson, and R. D. Ohmart. 1981. Vegetation characteristics associated with Abert's Towhee numbers in riparian habitats. *Auk* 98:818-827.
- Oberholser, H. C. 1974. The bird life of Texas. 536 p. University of Texas Press, Austin, TX.
- Phillips, A., J. Marshall, and G. Monson. 1964. The birds of Arizona. 212 p. University of Arizona Press, Tucson, AZ.
- Pinkowski, B. C. 1977. Breeding adaptations in the Eastern Bluebird. *Condor* 79:289-302.
- Rosenberg, K. V., R. D. Ohmart, and B. W. Anderson. 1982. Community organization of riparian birds: Response to an annual resource peak. *Auk* 99:260-274.
- von Haartman, L. 1957. Adaptation in hole-nesting birds. *Evolution* 11:339-347.
- Wecker, S. C. 1963. The role of early experience in habitat selection by the prairie deermouse, Peromyscus maniculatus bairdi. *Ecological Monographs* 33:307-325.
- Yeager, L. E. 1955. Two woodpecker populations in relation to environmental change. *Condor* 57:148-153.



# Breeding Bird Use of Flooded Dead Trees in Rathbun Reservoir, Iowa<sup>1</sup>

Teresa L. Burns<sup>2</sup> and Robert B. Dahlgren<sup>3</sup>

---

Abstract.--Birds using flooded dead trees in a large flood-control reservoir were compared with those using bottomland timber areas upstream. The flooded dead trees had a lower avian density and less diversity of species than unflooded areas, but a greater number of secondary cavity-nesting species. Nests of three primary cavity-nesting, six secondary cavity-nesting, and three open-nesting species were found in the flooded trees. Flooded trees add significantly to the nesting bird population of the reservoir.

---

## INTRODUCTION

With the construction of a large flood-control reservoir, thousands of acres of riparian habitat are inundated. Included in this loss is bottomland forest which may contain higher densities and diversities of birds than do the adjacent uplands (Odum 1978). It is very costly to remove the trees, and the current Corps of Engineers' policy is to remove as little timber from the reservoir as possible, clearing only for the dam site and for boating routes.<sup>4</sup> The remaining trees soon die after flooding, providing a unique habitat for cavity-dependent species of wildlife. It is estimated that many of the dead trees remain standing for about 25-30 years.<sup>5</sup> Yeager (1955) found that the number of woodpeckers increased in bottomland areas along the Mississippi River in Illinois as the result of flooding and killing of bottomland trees. There also has been some previous work done on flooded dead trees used by ducks in shallow reservoirs (Cowardin 1969) and by woodpeckers in beaver ponds during winter (Hair

et al. 1978, Lochmiller 1979). The purpose of this paper is to compare the bird use of dead trees and of bottomland timber.

## STUDY AREA AND METHODS

Rathbun Reservoir, located on the Chariton River in south-central Iowa, was chosen as the study site. Flooded dead trees, located only in the upper reaches of the reservoir, occupy about 10% (420 ha) of the reservoir's 4450 ha of surface area at the normal pool level of 904 feet above mean sea level (msl). The water level remained between 914 and 915 msl for most of the study, but in July 1982, it rose to the highest level (924 msl) ever recorded. There are two branches in the upper reaches of the reservoir: the North Fork, containing 80% of the flooded trees, and the South Fork, which contains the remaining 20%. Most of the land surrounding these two branches is managed for wildlife by the Iowa Conservation Commission. The reservoir was flooded in 1969, and all trees below 907 msl were killed by 1971.<sup>6</sup> Because of the turbidity of the water and the widely fluctuating water levels, there was no aquatic vegetation found around any of the flooded trees.

In addition to the flooded trees, bottomland timber 10-15 km upstream from the plots in the flooded trees also was censused. The bottomland areas chosen were all above the previous reservoir high of 918 msl and were not subject to the water level changes in the reservoir. The dominant tree species on the sample plots include silver maple

---

<sup>1</sup>Paper presented at the Snag Management Conference. [Arizona State University, Flagstaff, June 6-9, 1983.] Journal Paper No. J-11068 of the Iowa Agriculture and Home Economics Experiment Station, Ames; Project No. 2399. This study was funded by the Iowa Conservation Commission.

<sup>2</sup>Teresa L. Burns is a graduate student at Iowa State University, Ames, Iowa.

<sup>3</sup>Robert B. Dahlgren is Unit Leader of the Iowa Cooperative Wildlife Research Unit, Ames, Iowa. Agencies cooperating in the Unit are U.S. Fish and Wildlife Service, Iowa Conservation Commission, Iowa State University, and Wildlife Management Institute.

<sup>4</sup>Bryan, K. 1983. Personal conversation. U.S. Army Corps of Engineers, St. Louis, Mo.

<sup>5</sup>Thompson, D. Q. 1983. Personal conversation. U.S. Fish and Wildlife Service, Ft. Collins, Col.

---

<sup>6</sup>Brunk, E. L., A. D. Allman, and G. P. Dellinger. 1975. Mortality of trees caused by flooding during the growing season at two midwest reservoirs. Unpublished report. Missouri Dept. of Conservation, Jefferson City, Mo.



(*Acer saccharinum*), American elm (*Ulmus americana*), red elm (*Ulmus rubra*), hackberry (*Celtis occidentalis*), and green ash (*Fraxinus pennsylvanica*). Other tree species include pin oak (*Quercus palustris*), swamp white oak (*Quercus bicolor*), bitternut hickory (*Carya cordiformis*), shellbark hickory (*Carya lacinosis*), mulberry (*Morus rubra*), and hawthorn (*Crataegus* spp.).

Birds were censused in each of the areas by using a circular-plot method. All birds seen or heard within a 50-m radius in 10 minutes were recorded. Flying birds such as swallows that were foraging over the plot were included in the census, but aquatic birds resting on the water were not. Counts were begun in late May 1982 and continued through early July until all plots were censused four times. Forty plots were established, 20 each in the bottomland timber and flooded trees, with 10 plots on the South Fork and 30 on the North Fork of the river. Plots were censused in early morning and were systematically rotated as to the time when counts were made. Birds were censused from a canoe in the flooded trees. The flooded trees also were searched for evidence of nests. Nests that could not be viewed from the canoe were verified by observing at least three feedings of nestlings or by hearing nestlings in the nest.

Species diversity was calculated by using the Shannon formula ( $\sum - p \log p$ ). Species richness is the average number of species per plot. A t-test was used to test for differences between means.

Relative numerical component (RN) was calculated as the number of bird observations divided

by the number of observations for the most abundant species. Relative spatial component (RS) is the number of different plots on which the bird was observed divided by the total number of plots. Important value (IV) is equal to RN + RS.

## RESULTS AND DISCUSSION

Species diversity and species richness were greater in the bottomland timber than in the flooded trees (table 1). A total of 15 species were observed in the flooded trees during censusing as compared with 28 in the bottomland timber. Species diversity usually is associated with increasing complexity of the vegetation structure in a habitat (MacArthur 1964); however, dead trees (Balda 1975) and water (Karr 1968) may also increase diversity.

Table 1. Mean bird species diversity (H') and species richness (S) for census plots in flooded dead trees and bottomland timber areas during summer 1982 at Rathbun Wildlife Unit, Iowa. (Means were different;  $P < 0.0001$ )

	H'		S	
	$\bar{x}$	SE	$\bar{x}$	SE
Bottomland timber (N = 20)	1.97	0.05	10.25	0.56
Flooded timber (N = 20)	1.32	0.04	5.45	0.31

Table 2. Relative numbers, relative spatial components, and importance values by habitat for cavity-nesting birds during summer 1982 at Rathbun Wildlife Unit, Iowa. The mean numbers of birds per plot per census are given in parentheses.

Species	Flooded dead trees			Species	Bottomland timber		
	RN	RS	IV		RN	RS	IV
European starling (3.78) ( <i>Sturnus vulgaris</i> )	1.00	1.00	2.00	Red-headed woodpecker(0.88) ( <i>Melanerpes erythrocephalus</i> )	1.00	0.95	1.95
Tree swallow(2.41) ( <i>Iridoprocne bicolor</i> )	0.64	1.00	1.64	House wren(0.75) ( <i>Troglodytes aedon</i> )	0.86	1.00	1.86
House sparrow(1.90) ( <i>Passer domesticus</i> )	0.50	0.90	1.40	Black-capped chickadee(0.24) ( <i>Parus atricapillus</i> )	0.27	0.65	0.92
Red-headed woodpecker(0.69) ( <i>Melanerpes erythrocephalus</i> )	0.18	0.85	1.03	Great crested flycatcher(0.16) ( <i>Myiarchus crinitus</i> )	0.18	0.40	0.58
Northern flicker(0.24) ( <i>Colaptes auratus</i> )	0.06	0.55	0.61	Northern flicker(0.10) ( <i>Colaptes auratus</i> )	0.11	0.30	0.41
Common grackle(0.13) ( <i>Quiscalus quiscula</i> )	0.03	0.40	0.43	Barred owl(0.03) ( <i>Strix varia</i> )	0.03	0.10	0.13
Wood duck(0.04) ( <i>Aix sponsa</i> )	0.01	0.05	0.06	White-breasted nuthatch(0.03) ( <i>Sitta carolinensis</i> )	0.03	0.10	0.13
House wren(0.01) ( <i>Troglodytes aedon</i> )	< 0.01	0.05	0.05	Red-bellied woodpecker(0.03) ( <i>Melanerpes carolinus</i> )	0.03	0.10	0.13
Red-bellied woodpecker <sup>1</sup> (0) ( <i>Melanerpes carolinus</i> )	0	0	0	Hairy woodpecker(0.01) ( <i>Picoides villosus</i> )	0.01	0.05	0.06
Great crested flycatcher <sup>1</sup> (0) ( <i>Myiarchus crinitus</i> )	0	0	0	Downy woodpecker(0.01) ( <i>Picoides pubescens</i> )	0.01	0.05	0.06

<sup>1</sup>Species was not observed during censusing but their nests were found in flooded dead trees.



Lack of foliage probably is the major reason for less species diversity in the flooded trees.

In comparing bird species found in flooded trees with those in bottomland timber, birds were divided into two groups based upon their nesting habit, primary or secondary cavity-nesting. The number of secondary cavity-nesting species was greater ( $P < 0.0001$ ) in the flooded trees ( $\bar{x} = 32.0$ ) than in the bottomland timber ( $\bar{x} = 4.8$ ). Starlings, tree swallows, and house sparrows had the highest importance values in the flooded trees (table 2), making up 88% of birds observed there. None of these species was observed in the bottomland timber. The secondary cavity-nesting species that are found in both areas are the great crested flycatcher and house wren; however, both had much higher importance values in the bottomland timber (table 2).

Although there were more secondary cavity-nesting species in the flooded trees, the number of primary cavity-nesting birds ( $\bar{x} = 3.6$  for flooded trees,  $\bar{x} = 4.0$  for bottomland timber) did not differ between the areas ( $P = 0.66$ ), though there were more birds seen in the bottomland timber. The red-headed woodpecker had the highest importance value for primary cavity nesters in both areas (table 2), followed by the northern flicker and red-bellied woodpecker. Yeager (1955) found red-headed woodpeckers to be the most numerous woodpecker 1 to 8 years after flooding at a dam built near the confluence of the Illinois and Mississippi rivers. Lochmiller (1979) also found that the red-headed woodpecker was the most common of seven woodpeckers using flooded dead trees in beaver ponds in Georgia during winter. Downy and hairy woodpeckers were not observed in the flooded trees at all and only rarely in the bottomland timber at Rathbun.

Nests were found of all species observed during the censusing in the flooded trees except those of chimney swifts (*Chaetura pelagica*), barn swallows (*Hirundo rustica*), American crows (*Corvus brachyrhynchos*), blue jays (*Cyanocitta cristata*), and red-winged blackbirds (*Agelaius phoeniceus*). These species used the flooded trees mainly as perch sites and for aerial foraging for insects. In contrast, all the birds that nested in the flooded trees were seen flying into adjacent upland woodlands, row crops, and pastures to forage. Such foraging must be necessary to support the large numbers of cavity-nesting birds in the flooded trees.

Nests of three open-nesting species were found in the flooded trees including those of red-tailed hawk (*Buteo jamaicensis*) and eastern kingbird (*Tyrannus tyrannus*) in 1982 and, in spring of 1983, a mallard (*Anas platyrhynchos*). There is a great blue heron (*Ardea herodias*) colony with about 20 nests in the flooded trees as well as a

smaller colony with 6 nests located in live bottomland trees near the gradient between the reservoir and river. Two of the open-nesting species, red-tailed hawk and great blue heron, used snags with limbs to support their nests, whereas eastern kingbird and mallard nests were all on stumps.

## CONCLUSIONS

Although this study was conducted in the summer, flooded and downed trees were used by birds throughout the year. Migrating ducks often used fallen trees as resting areas, and raptors used dead trees as perch sites. Although flooded trees cannot mitigate the loss of the diversity and richness of bird species in bottomland timber, their presence can increase the number of birds nesting in the area for about 30 years. The low species diversity value in the flooded trees is greater than the value that would have occurred if the trees had been cleared.

## LITERATURE CITED

- Balda, R. P. 1975. Vegetation structure and breeding bird diversity. p. 55-88. In D. R. Smith, Tech. Coord. Symposium on management of forest and range habitat for non-game birds. U.S. Dep. Agric., For. Serv. Gen. Tech. Rep. WO-1.
- Cowardin, L. M. 1969. Use of flooded timber by waterfowl at the Montezuma National Wildlife Refuge. J. Wildl. Manage. 33(4):829-842.
- Hair, J. D., G. T. Hepp, L. M. Luckett, K. P. Reese, and D. K. Woodward. 1978. Beaver pond ecosystems and their relationships to multi-use natural resource management. p. 80-92. In R. R. Johnson and J. F. McCormick, tech. coords. Strategies for protection and management of floodplain wetlands and other riparian ecosystems. U.S. Dep. Agric., For. Serv. Gen. Tech. Rep. WO-12.
- Karr, J. R. 1968. Habitat and avian diversity on stripmined land in east-central Illinois. Condor 70(4): 348-357.
- Lochmiller, R. L. 1979. Use of beaver ponds by southeastern woodpeckers in winter. J. Wildl. Manage. 43(1):263-266.
- MacArthur, R. H. 1964. Environmental factors affecting bird species diversity. Am. Nat. 98(903):387-397.
- Odum, E. P. 1978. Ecological importance of the riparian zone. p. 2-4. In R. R. Johnson and J. F. McCormick, tech. coords. Strategies for protection and management of flood plain wetlands and other riparian ecosystems. U.S. Dep. Agric., For. Serv. Gen. Tech. Rep. WO-12.
- Yeager, L. E. 1955. Two woodpecker populations in relation to environmental change. Condor 57:148-153.



# Nestholes in Live and Dead Aspen<sup>1</sup>

Barbara L. Winternitz and Helen Cahn<sup>2</sup>

Abstract.--A comparison of three studies in two Colorado montane aspen stands indicated that almost 40% of birds breeding in aspen used nestholes. Over 50% of the nesthole trees were infected by *Fomes igniarius* conks. Nesthole trees were larger than the other aspen, and estimated to average well over 100 years in age.

## INTRODUCTION

Almost half of the birds breeding in Colorado montane forests use nestholes to protect their eggs and young, and many of the species show a preference for Quaking Aspen, *Populus tremuloides* Michx., vegetation and nestholes drilled in aspen.

Here we want to present data gathered in three studies of two areas in Colorado aspen, to show the interesting relationships found between the birds, their nestholes, the aspen and other vegetation parameters.

## STUDY AREAS AND METHODS

A first study site was in Crow Gulch, on Pikes Peak, near Colorado Springs, CO. A twenty hectare (ha.) grid was studied in a five year breeding bird spot-map census from 1967 to 1971. Elevation varied from 2658 to 2762 meters (m). The balanced montane vegetation there included Douglas Fir (*Pseudotsuga menziesii*), pines (*Pinus ponderosa* and *P. flexilis*) and spruce (*Picea* spp.) as well as riparian aspen growths. Most of the breeding bird species here showed a preference for aspen (Winternitz, 1976). In 1977 and 1978, measurements of the nesthole trees and mapping of Heartrot Fungus (*Fomes igniarius*) were completed.

The second study site was on Black Mountain, near Fairplay, Colorado, at a slightly higher elevation near 3,000 m. The 24 ha. grid supported a stable aspen vegetation present in all age classes. Few conifers were found, and no open water was nearby. The constant slope to the west minimized topographic and climate differences. Figure 1 depicts the site, and shows the separation of the aspen into a lower and upper grove by the presence of a meadow alleyway.

<sup>1</sup>Paper presented at the Snag Habitat Management Symposium, Flagstaff, Arizona, 7-9 June 1983.

<sup>2</sup>Barbara L. Winternitz, Assistant Professor of Biology, The Colorado College, Colorado Springs, CO 80903, and Helen Cahn, The Biology Department, The Colorado College, Colorado Springs, CO 80903.

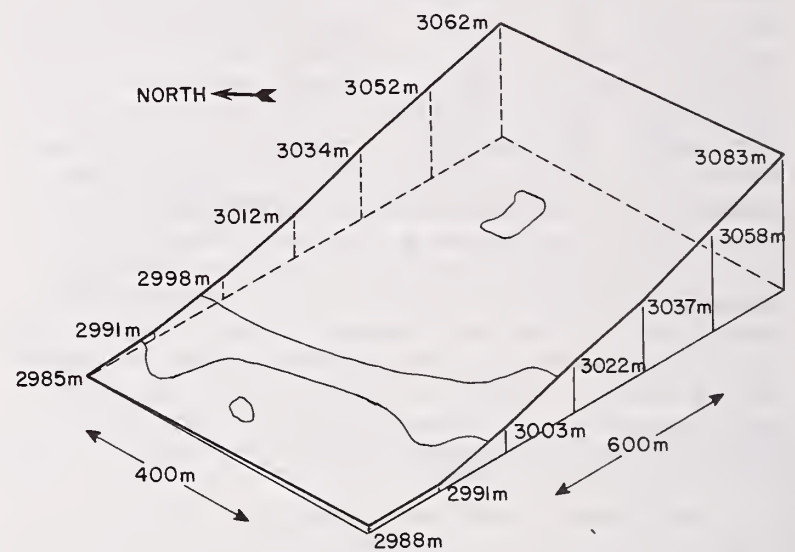

Figure 1. Model of the Black Mountain study area.

A five year breeding bird census was made from 1978 to 1982, using the spot-map method (Williams, 1936). During these five years the location of all nestholes found was recorded, and measurements taken of the trees, the holes, and *Fomes* infection. In Hectare II, all trees were inspected for the fungus, and measured and marked if infected. In 1981 and 1982, the vegetation of the entire site was sampled using a combination of the point-quarter method and Daubenmire's Nested Boxes technique (Daubenmire, 1968).

In 1982, 47 individual aspens were core-sampled to determine the relationship between DBH (diameter breast high) and age of the tree. Trees were selected to represent three elevational divisions of the area, the upper upper grove (3034-3067 m. high), the lower upper grove (2998-3034 m.), and the lower grove (2983-2991 m.). The trees were chosen randomly throughout each division, and the DBH of the sampled trees was comparable to that of healthy trees sampled by the

methods listed above, except that larger trees were more successfully cored than smaller ones, so a slight advantage was given to the larger aspen.

DBH was measured with a tree tape, and an increment borer was used 1 foot from the ground on the tree's south side to extract a core sample (after Campbell, 1981). Height of the tree and canopy dimensions were measured with a clinometer. Core samples were soaked in a 75:24:1 by weight solution of methanol, water, and laboratory detergent for 24 hours, and then shaved to display a transverse view of the rings. Rings were counted and one year added to the count, the average amount of time it takes aspen to grow one foot (Campbell, 1981). Out of 47 trees sampled, 40 were successfully aged. Even the initial stages of *Fomes* infection made reading of the ring count difficult, so the correlation between age and DBH is applicable only to healthy live trees.

The third study reported here was performed by Anthony Ham in the vicinity of both of the above sites. After helping to identify the nestholes in the two grid areas, he measured other nesthole trees nearby (Ham, 1978).

## RESULTS

The species and numbers of birds nesting in holes at Black Mountain are emphasized here, as those in Crow Gulch could utilize other coniferous vegetation as well as the aspen. Comparison of the species in the two sites is shown in Table 1.

Table 1. Primary and Secondary Cavity Nesting Birds.

Species	Density/ Black Mt. Av. prs/yr	Presence Crow Gulch
<b>Primary Cavity Nesters:</b>		
Hairy Woodpecker, <i>Picoides villosus</i>	2.0	present
Downy Woodpecker, <i>Picoides pubescens</i>	1.2	present
Yellow-bellied Sapsucker, <i>Sphyrapicus varius</i>	1.5	Williamson's Sapsucker, <i>S. thyroideus</i>
Northern Flicker, <i>Colaptes auratus</i>	2.0	present
<b>Secondary Cavity Nesters:</b>		
White-breasted Nuthatch, <i>Sitta carolinensis</i>	2.2	present
Red-breasted Nuthatch, <i>Sitta canadensis</i>	0.8	present
Mountain Chickadee, <i>Parus gambeli</i>	8.0	present
Black-caped Chickadee, <i>Parus atricapillus</i>	0.3	present
House Wren, <i>Troglodytes aedon</i>	7.0	present

Table 1, cont.

Species	Density/ Black Mt. Av. prs/yr	Presence Crow Gulch
Western Flycatcher, <i>Empidonax difficilis</i>	1.2	present
Tree Swallow, <i>Tachycineta bicolor</i>	6.2	Violet-green Swallow, <i>T. thalassina</i>
Mountain Bluebird, <i>Sialia currucoides</i>	5.6	Western Bluebird, <i>Sialia mexicana</i>

At Black Mountain, the nesting categories were:

%	By numbers	By biomass
1°	7%	20%
2°	32%	18%
	39%	38%

Either way you look at it, 40% of the nesting birds used holes in which to nest.

## Nestholes

Nestholes discovered at Black Mountain are presented in Figure 2. Obviously they were evenly distributed between live and dead aspen, and were most common in the lower aspen grove.

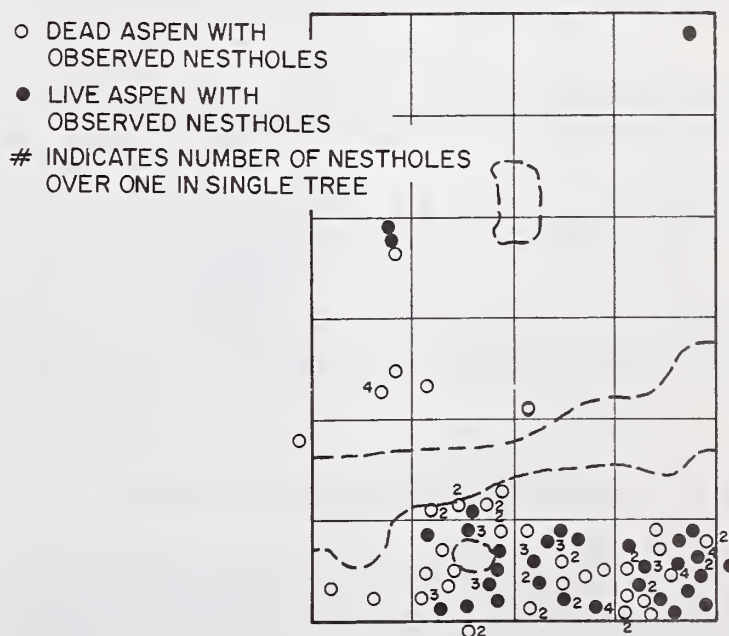

A tabular analysis of nesthole measurements in the three aspen studies is seen in Table 2.



Table 2. Nesthole Measurements in the three studies.

Measurement	Crow Gulch	Black Mountain	Ham Study
# aspen trees with holes	32	67	10
# nestholes	37	106	18
% <i>Fomes</i> infected	62%	55%	--
av. DBH of tree	19.72cm	29.22	26.4
range DBH	(8.8-30.7)	(17.8-34.9)	(24.6-30.7)
av. height of hole	4.21m	3.96m	3.43m
range of height	(1.2-10m)	(1.2-9.1m)	(1.4-5.1m)

Figure 3 shows the orientation of nestholes at both Crow Gulch and Black Mountain.

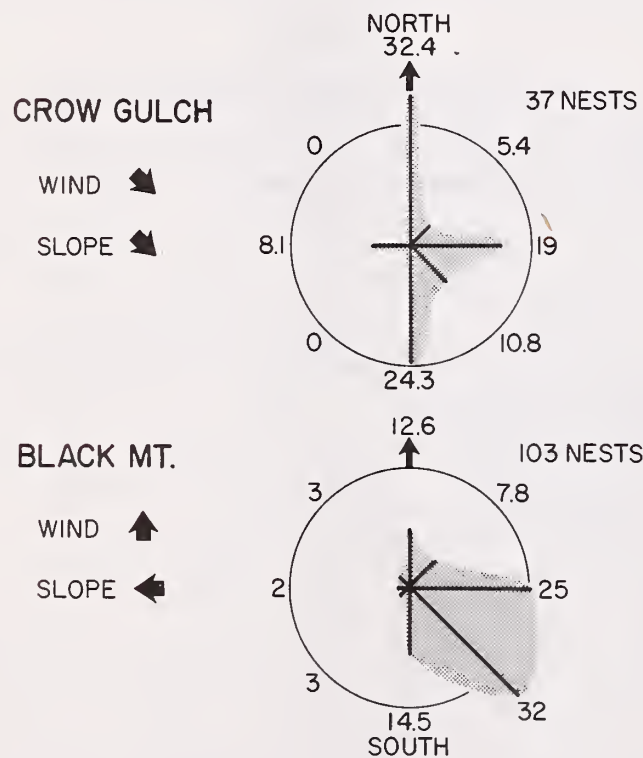

Figure 3. Orientation of bird nestholes in aspen.

At Crow Gulch the strongest winds came from the north and northwest, though ridges protected the study site from them. At Black Mountain, 72% of the winds during June and July came from the southeast, south and southwest, as did the strongest wind--30 mph (U.S. For. Service, 1982).

Table 3. Relative sizes of Black Mountain nestholes.

Round holes		Oblong holes	
2.54cm	8	2.54 x 3.8cm	1
3.17	1	3.17 x 3.8	1
3.8	13	3.8 x 5.1	9
5.1	7	3.8 x 6.3	1
6.3	3	5.1 x 7.6	1
7.6	7	7.6 x 8.9	3

Vegetation Parameters  
 Age-DBH Correlation for Aspen

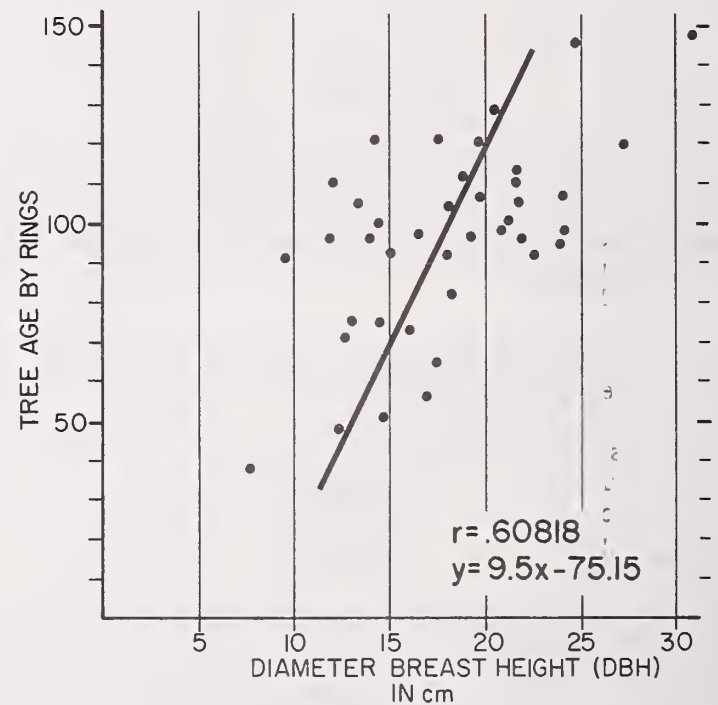

Figure 4. Aspen DBH and age correlated.

In Figure 4, the correlation coefficient,  $r = +.60818$ , tests to be a highly significant relationship ( $p < .01$ ).

#### Fomes Infection

In Hectare II, where all the aspen trees were counted and measured, 11% of 1915 trees were found to be visibly infected by the fungus.

The incidence of *Fomes* in all 24 has. varied from 0 to 17.75%, and showed as a highly significant difference between hectares.

Figure 5 shows the relationship between percent fungus infection and nesthole numbers.

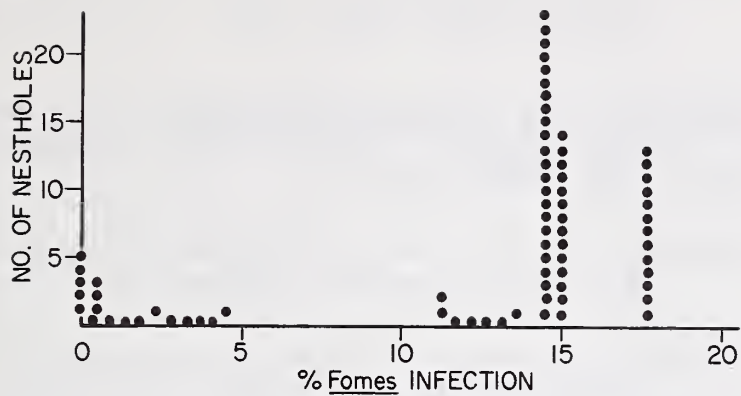

Figure 5. Fomes incidence and nesthole numbers.

A correlation coefficient of  $R = + .54653$  indicates a significant relationship ( $p < .02$ ).

### DISCUSSION

Many Colorado aspen groves are seral stands, subject to future replacement by coniferous trees. In Crow Gulch the riparian nature of the aspen, and the presence of young conifers in the understory, made it difficult to judge the permanence of aspen there.

At Black Mountain, the presence of aspen in all age classes (to 146 years!) and the lack of healthy young conifers, indicates it is a stable aspen stand, as described by Marr, 1967.

The clumping of Black Mountain nestholes in the lower aspen grove (Figure 2) showed the primary cavity nesters were attracted to that area for hole-drilling for some reason. It was not the larger size of the trees, for DBH measurements do not vary significantly from hectare to hectare. It may be related to edge effect (more edge in the lower grove) and/or aspen density (lower tree density in the lower grove). Certainly it is related to Heartrot Fungus infection level (Figure 5). The strong correlation shown between nesthole number and percent infection of Fomes leads one to wonder why 60% or less of the nesthole trees showed visible infection. The reason for this may be the presence of less detectable heartrots, such as Cryptochaete polygonia (Davidson et al, 1959) and said by them to be responsible for nearly 10% of aspen rot. This fungus is also referred to as Peniophora polygonia (Hinds and Wengert, 1977) and said to cause over 14% of aspen rot in their study. Perhaps the woodpeckers can identify this heartrot better than we can.

The relationship of DBH, age of tree, and fungus infection is somewhat less clear, due to our inability to read core rings in infected trees. We found in our core analysis that the trees in the lower grove were younger (av. age 96.7 yrs) and bigger in DBH (19.6 cm av.). In contrast, the upper grove trees averaged 101 years in age, and showed a diminution in DBH as one went upslope (18.11 cm to 16.56 cm). There was a stronger correlation of age and DBH in the lower grove ( $r = + .768$ ). The weakest correlation of age and DBH was found in the upper upper grove,  $r = + .5588$ .

However, we do not know what effect the fungus has on the tree DBH. Perhaps Fomes infection increases tree DBH and therefore our estimate is too high. Using this correlation method in the groves, the average age of a nesthole tree was estimated to be over 170 years old.

Inspection of the various nesthole measurements (Table 2 and Figure 3) showed little variability in average DBH of nesthole trees or the average height of a nesthole. Much more variability was shown in the orientation of nestholes, with more Crow Gulch nestholes facing north, then south and east, while Black Mountain holes showed a strong south and east orientation. It appeared nesthole openings are oriented toward the sun rather than away from the wind. But the positioning of hole openings to all directions at Black Mountain indicated a degree of individual choice as to view.

Hole sizes, Table 3, illustrate a wide range of shape and diameters. Harrison, 1979, typified:

- Downy Woodpecker holes as 3.2 cm in a perfect circle, analogous to the smaller round holes (11 in number)
- Hairy Woodpecker holes as 5.1 x 6.3 cm oblong (12 in number at Black Mountain)
- Flicker holes as over 7 cm round or oblong (12 in number at Black Mountain)
- Yellow-bellied Sapsucker holes as 3.8 cm and round (13 at Black Mountain)

The relative numbers of woodpecker species (Table 1) and such sized nestholes are equitable--but who drilled the 9 holes 3.8 x 5.1 cm in oblong shape?

### SUMMARY

1. The aspen at Black Mountain form a stable vegetation community.
2. More nestholes are drilled by birds in the lower grove due to:
  - a. higher heartrot infection
  - b. perhaps due to lower tree density and/or greater proximity to edge.
3. The lower grove was slightly younger in age (av. 97 yrs) and bigger in girth than the upper groves.
4. Nestholes vary little in average height above the ground but greatly in orientation toward the sun. Wind does not seem to be as strong a factor as sunlight in their placement.

### ACKNOWLEDGEMENTS

Support for the Black Mountain study was given by Research and Development funds of The Colorado College and a Benezet Summer Research stipend from Colorado College. Also, we want to thank Dave Buck, Kris Fennie, Tony Ham, Belinda Platts, and the students of many Ecology, Field Zoology, and Ornithology classes for assistance in the field.



### LITERATURE CITED

- Campbell, R.B., Jr. 1981. Field and laboratory methods for age determination of Quaking Aspen. USDA For. Serv. Res. Note INT 314.
- Daubenmire, R. 1968. Plant communities. Harper & Row, NY.
- Davidson, R.W., T.E. Hinds, and F.G. Hawksworth. 1959. Decay of aspen in Colorado. USDA For. Serv. Station paper 45, Rky. Mt. For. & Range Exp. Station, Ft. Collins, CO.
- Ham, A.L. 1978. An analysis of nesthole data collected in the Crow Gulch and Black Mt. aspen areas. Colorado College Field Zoology paper.
- Harrison, H.H. 1979. A field guide to western birds' nests. Houghton-Mifflin, Boston, MA.
- Hinds, T.E. and E.M. Wengert. 1977. Growth and decay losses in Colorado aspen. USDA For. Serv. Res. Paper RM-193, Ft. Collins, CO.
- Marr, J.W. 1967. Ecosystems of the east slope of the Front Range in Colorado. Colo. Associated Univ. Press, Boulder, CO.
- U.S. Forest Service. 1982. AFFIRMS-NFDRS Weather OBS. April-August, 1982. Fairplay, CO.
- Williams, A.B. 1936. The composition and dynamics of a beech-maple climax community. Ecol. Monog. 6:317-408.
- Winternitz, B.L. 1976. Temporal change and habitat preference of some montane breeding birds. Condor. 78: 383-393.



# Snag Density and Utilization by Wildlife in the Upper Piedmont of South Carolina<sup>1</sup>

D. Breck Carmichael, Jr. and David C. Guynn, Jr.<sup>2</sup>

---

Abstract.--Snag densities were estimated for major forest types on the Clemson Experimental Forest, in the upper Piedmont of South Carolina. Two-hundred 0.1-ha plots were established in various aged stands of cove hardwood, upland hardwood, pine-hardwood, and pine plantations. Climbable snags containing cavities were inspected to determine use by wildlife during warm months (May-September) and again during cold months (November-March). Mean snag densities were 50.3 snags per ha for upland hardwoods, 37.3 snags per ha for cove hardwoods, 31.2 snags per ha for pine-hardwoods, and 21.3 snags per ha for pine plantations. Cavities occurred in only 8.8% of all snags tallied. Preliminary results indicate that more than 35% of snags with cavities were utilized by southern flying squirrels (Glaucomys volans).

---

## INTRODUCTION

In most natural communities, nongame species constitute the greatest portion of vertebrate species and biomass; furthermore, they are critical to the functioning of the ecosystem (Bury et al. 1980). Wildlife researchers and managers are now aware of the importance of standing dead trees, or snags, as habitats for many of these species. Activities such as bird watching and wildlife photography have become popular (More 1979), with annual expenditures totalling in the millions of dollars in the United States (DeGraaf and Payne 1975). Also, many species of snag-dependent wildlife are insectivorous and help prevent insect populations from reaching epidemic levels (Beebe 1974).

Information on snags and snag-dependent species is lacking in the Southeast. Extensive studies have been carried out on the endangered red-cockaded woodpecker (Picoides borealis), but this species requires live southern pines (Pinus spp.) for cavity construction. All other southern woodpeckers utilize snags for cavity construction,

and a large number of secondary cavity-nesters use these cavities. Some 38 species of birds that breed and/or winter in upper South Carolina are known to utilize snags (Legrand and Hamel 1980). Several mammalian species nest, feed, or hibernate in snags; and amphibians and reptiles may even use snags (McComb and Noble 1981). We initiated a study in 1981 to estimate snag densities in 4 major forest types in the upper Piedmont of South Carolina and to determine the diversity of wildlife species utilizing snags within these forest types.

## STUDY AREA

The study was conducted on the 7,024 ha Clemson University Experimental Forest, in the upper Piedmont of South Carolina. The tract was obtained between 1934 and 1939 from private owners by the U. S. Department of Agriculture. More than 100 years of clearing, burning, row cropping and abandonment had turned the area into severely eroded red clay hills and gullies. The scattered woodlands present were mostly rough pines and low quality hardwoods. Federal work programs helped initiate the reforestation of the area, and in 1954 the land was deeded to Clemson University. An intensive forest management program has restored the Clemson Forest to a productive state (Warner et al. 1973).

All study plots were established on the "North Forest," maintained primarily for research, teaching, and recreation. The terrain is slightly

---

<sup>1</sup>Paper presented at the Snag Habitat Management Symposium, Northern Arizona University, Flagstaff, June 7-9, 1983.

<sup>2</sup>D. Breck Carmichael Jr. and David C. Guynn, Jr. are, respectively, Graduate Research Assistant and Associate Professor, Department of Forestry, Clemson University, Clemson, S.C.



rolling to hilly, typical of the upper Piedmont. Stands ranged in size from less than 0.5 ha to greater than 10 ha, and all ages from seedlings to mature sawtimber were present.

#### METHODS

Four stands in each of the 10 following forest types were located on the study area: pine-hardwood - 20 to 30 years, pine-hardwood - 30 to 50 years, pine-hardwood - over 50 years, pine plantation - 1 to 9 years, pine plantation - 20 to 40 years, pine plantation - over 40 years, cove-hardwood - 40 to 60 years, cove-hardwood - over 60 years, upland hardwood - 40 to 60 years, and upland hardwood - over 60 years. Within each of the 40 stands, five 0.1 ha (20 m x 50 m) study plots were randomly located and a 100% tally of all snags was made. A snag was defined as any dead or mostly dead standing tree at least 10.2 cm (4 in) dbh and 1.8 m (6 ft) tall. Total height and dbh were measured, and each snag was numbered at breast height with CFI paint and at stump height with an aluminum tag. Climbable snags containing cavities were inspected to determine use by wildlife during warm months (May-September) and again during cool months (November-March). Sample size fluctuated due to snags falling between successive cavity inspection periods. For purposes of the determination of wildlife use, new cavity trees were continually added to the sample whenever found, so that some cavity trees were inspected as many as 3 times and some only once. Snag densities by forest type were compared by analysis of variance (Sokal and Rohlf 1973). The number of snags required for nesting by indigenous avian cavity nesters was estimated as discussed by Harlow and Guynn (1983) and compared with the number of snags found on the study area.

#### RESULTS AND DISCUSSION

Upland hardwood stands contained significantly ( $P < 0.01$ ) greater numbers of snags than other stand types (Table 1). Forest management practices on the Clemson Forest have resulted in a large number of snags in all stand types compared to some other southern forests. McComb and Muller (1983) reported high snag densities in eastern Kentucky, but their study areas had received no management for 40 years or more. Snag densities on the Francis Marion National Forest (FMNF), in the Coastal Plain of South Carolina were found to be much lower than those in the present study (Harlow and Guynn 1983). Pine stands on FMNF contained approximately 84% fewer snags than hardwood and mixed pine-hardwood stands of the Clemson Forest, mostly because lightning struck and beetle (*Dendroctonus frontalis* and *Ips* spp.) killed trees are removed from the FMNF soon after detection. Snags are generally not removed from the Clemson Forest. Beetle kills are sometimes salvaged, but not as often as on the

Table 1.--Mean snag densities on the Clemson Experimental Forest ("North Forest") in the Piedmont of South Carolina, 1982.

Stand Type	Snags per hectare	
	$\bar{x}$	SE
Upland hardwood	50.3**	6.27
Cove hardwood	37.3	4.56
Pine hardwood	31.2	2.86
Pine plantation	21.3	2.96

\*\*  $P < 0.01$

FMNF. The hilly terrain on the Clemson Forest makes some areas inaccessible for salvage whereas a number of private salvage operators eagerly compete for dead and dying timber on the more accessible FMNF. Forests of the Coastal Plain also have a smaller hardwood component than those of the Piedmont, and the FMNF is open to public firewood cutting. Firewood cutting is strictly prohibited on the Clemson Forest, except in designated areas which were not part of the study area. Prescribed fire is used more frequently in pine stands of the FMNF than those of the Clemson Forest. Additionally, one of the major management practices in hardwood stands of the Clemson Forest has been to girdle or chemically inject undesirable stems.

Differences in biotic and abiotic factors in the Coastal Plain and the Piedmont may also explain differences in snag densities. There are probably a greater variety of diseases operating as tree mortality factors in the Piedmont. For example, littleleaf disease (*Phytophthora cinnamomi*) is frequent on the Clemson Forest due to the prevalence of red clay soils but is mostly absent from the sandy soils of the Coastal Plain. Climatic factors such as ice storms are more frequent and severe in the Piedmont than in the Coastal Plain.

Snag densities on the Clemson Forest were much greater in the 10.1-25.0 cm diameter class than in the larger diameter classes (Table 2). Sixteen snags were in such an advanced stage of decomposition that an accurate dbh measurement was impossible. These snags were included in the calculation of density by forest type but were excluded from density by diameter class and forest type. Estimates of optimum snag size and densities required to support selected cavity-nesting birds at various population levels are presented in Table 3. These requirements should be considered minimum because no reserve snags were included in the estimates. Bull and Meslow (1977) and Thomas et al. (1979) recommended 16 and Evans and Conner (1979) 10 reserve snags for each snag utilized; but at this time, there is no biological basis for reserve snag estimates (Harlow and Guynn 1983). Cavity-nesters that require snags in the 10.1-25.0 cm dbh range, such as the downy woodpecker (*Picoides pubescens*), Carolina chickadee (*Parus carolinensis*), and eastern



Table 2.--Mean snag densities by diameter class on the Clemson Experimental Forest ("North Forest") in the Piedmont of South Carolina, 1982.

Dbh Class (cm)	Snags per hectare				
	<sup>1</sup> UHW	<sup>2</sup> CHW	<sup>3</sup> PHW	<sup>4</sup> PP	Overall
10.1-25.0	41.8	28.8	23.8	14.7	27.3
25.1-40.0	6.3	4.8	6.3	5.8	5.8
40.1-55.0	0.8	1.5	0.8	0.2	0.8
> 55.0	0.5	0.3	0.0	0.0	0.2
Total	49.3	35.3	31.0	20.7	34.1

- <sup>1</sup>Upland hardwood  
<sup>2</sup>Cove hardwood  
<sup>3</sup>Pine hardwood  
<sup>4</sup>Pine plantation

Table 3.--Optimum snag size and minimum snag densities for selected cavity-nesting birds in the Southeastern United States.

Species	<sup>1</sup> Dbh of cavity tree (cm)	<sup>2</sup> Snags/ha required to support various population levels		
		100%	60%	20%
Pileated woodpecker	45.7-66.0	0.15	0.10	0.02
Red-bellied woodpecker	35.6-53.5	0.52	0.32	0.10
Downy woodpecker	15.2-25.4	0.32	0.20	0.07
Barred owl	50.8+	0.10	0.05	0.02
Wood duck	50.8+	0.30	0.17	0.05
White-breasted nuthatch	30.5+	0.35	0.20	0.07
Tufted titmouse	30.5+	0.90	0.54	0.17
Eastern bluebird	20.3+	0.25	0.15	0.05
Carolina chickadee	15.2+	0.69	0.54	0.15
Total	-----	3.58	2.27	0.70

- <sup>1</sup>Adapted from Evans and Conner (1979)  
<sup>2</sup>Adapted from Harlow and Guynn (1983)

bluebird (*Sialia sialis*) probably can find sufficient snags to support 100% maximum population levels on the Clemson Forest (Tables 2 and 3). Avian species that utilize snags in the 25.1-40.0 cm dbh range can also find favorable habitats in terms of the density of suitable-sized snags. This group includes species such as the tufted titmouse (*Parus bicolor*) and the white-breasted nuthatch (*Sitta carolinensis*). The Clemson Forest does not contain adequate numbers of suitable snags for species that require larger snags (dbh 40.1-55 cm and greater) such as the pileated woodpecker (*Dryocopus pileatus*), red-bellied woodpecker (*Melanerpes carolinus*), barred owl (*Strix varia*), and wood duck (*Aix sponsa*).

Snags containing cavities made up only 8.8% of all snags tallied in the original survey

(N = 654). Seasonal cavity inspections are still underway, but preliminary results (N = 107) indicate a high rate of utilization by southern flying squirrels (*Glaucomys volans*) (Table 4). Few inspections have taken place during the peak nesting season for most avian cavity-nesters, and it is expected that the rate of utilization by birds will increase as the study continues. Undoubtedly, some snags for which wildlife use could not be determined were being used by birds as roosting sites. On several occasions, cavities initially occupied by downy woodpeckers and even the large pileated woodpecker, were occupied by flying squirrels at the next inspection period. In a study on interspecific competition for red-cockaded woodpecker cavities on the FMNF, Harlow and Lennartz (In Press) found that flying squirrels used 32% of the cavities inspected. Whether there is direct aggressive conflict between flying squirrels and other species is not known. Silver-haired bats (*Lasionycteris noctivigans*) were found roosting behind the loose bark of snags and are, therefore, not dependent on the presence of cavities. A number of herptofauna were observed during cavity inspections, but no attempt was made to enumerate or identify these species.

Table 4.--Utilization of snags as cavity sites by various wildlife species on the Clemson Experimental Forest ("North Area") in the Piedmont of South Carolina, 1982-83.

Species	Percent of cavity inspections				
	<sup>1</sup> CHW	<sup>2</sup> UHW	<sup>3</sup> PHW	<sup>4</sup> PP	Overall
Southern flying squirrel	23.8	35.7	36.4	43.6	36.4
Gray squirrel	14.3	7.1	9.1	2.6	7.5
Downy woodpecker	4.8	----	3.0	2.6	2.8
Pileated woodpecker	----	----	----	10.3	3.7
Red-bellied woodpecker	----	----	----	2.6	0.9
Red-headed woodpecker	----	----	----	2.6	0.9
Brown-headed nuthatch	----	----	----	2.6	0.9
Common flicker	----	7.1	----	----	0.9
Silver-haired bat	----	----	3.0	2.6	1.9
Undetermined	57.1	50.0	45.4	30.8	43.0

- <sup>1</sup>Cove hardwood  
<sup>2</sup>Upland hardwood  
<sup>3</sup>Pine hardwood  
<sup>4</sup>Pine plantation

#### CONCLUSIONS

Management practices that favor the creation and retention of snags have resulted in high snag densities on the Clemson Forest compared to other managed southern forests. Snag densities are



probably adequate for cavity-nesting species that can utilize snags 40 cm dbh or less but may be limiting for species that require larger snags. A large percentage of snags with cavities are utilized by southern flying squirrels. Where flying squirrels are abundant, competition between other cavity-dependent wildlife species and squirrels may be serious.

#### LITERATURE CITED

- Beebe, S. B. 1974. Relationships between insectivorous hole-nesting birds and forest management. Yale Univ., Sch. For. Environ. Stud., New Haven, Conn. 49 pp.
- Bull, E. L. and E. C. Meslow. 1977. Habitat requirements of the pileated woodpecker in northeastern Oregon. J. For. 75(6):335-337.
- Bury, B. R., H. W. Campbell, and N. J. Scott, Jr. 1980. Role and importance of nongame wildlife. Trans. N. Am. Wildl. Nat. Resour. Conf. 80:197-207.
- DeGraaf, R. M. and B. Payne. 1975. Economic values of nongame birds and some urban wildlife research needs. Trans. N. Am. Wildl. Nat. Resour. Conf. 40:281-287.
- Evans, K. E. and R. N. Conner. 1979. Snag management. In management of north central and northeastern forests for nongame birds. USDA For. Serv. Gen. Tech. Rep. NC-51. pp. 214-225.
- Harlow, R. F. and D. C. Gynn, Jr. 1983. Snag densities in managed stands of the South Carolina Coastal Plain. In press, South. J. Applied Forestry.
- \_\_\_\_\_ and M. R. Lennartz. In Press. Interspecific competition for red-cockaded woodpecker cavities during the nesting season in South Carolina. Proc. Red-cockaded Woodpecker Symp. II. Panama City, FL.
- LeGrand, H. E., Jr. and P. B. Hamel. 1980. Bird-habitat associations on southeastern forest lands. Dept. of Zoology, Clemson Univ., Clemson, S.C. 276 pp.
- McComb, W. C. and R. E. Noble. 1981. Nest-box and natural cavity use in 3 mid-south forest habitats. J. Wildl. Mgmt. 45(1):93-101.
- \_\_\_\_\_ and R. N. Muller. 1983. Snag densities in old-growth and second-growth Appalachian forests. J. Wildl. Mgmt. 47(2):376-382.
- More, T. A. 1979. The demand for nonconsumptive wildlife uses: a review of the literature. USDA For. Serv. Gen. Tech. Rep. NE-52. 16 pp.
- Sokal, R. R. and F. J. Rohlf. 1973. Introduction to biostatistics. W. H. Freeman and Co., San Francisco. 386 pp.
- Thomas, J. W., R. G. Anderson, C. Maser, and E. L. Bull. 1979. Snags. In J. W. Thomas (ed.). Wildlife habitats in managed forests, the blue mountains of Oregon and Washington. USDA Agric. Handb. 553. Washington, D.C. pp. 60-77.
- Warner, J. R., L. D. Reamer, N. B. Goebel, C. L. Lane, T. E. Gaylord, and A. C. Malcolm. 1973. The Clemson forest, purpose - objectives - policies. Clemson University, Dept. of Forestry, Tech. Pap. No. 1. 10 pp.

# Use of Dead Trees by the Endangered Indiana Bat<sup>1</sup>

John T. Brady<sup>2</sup>

---

Abstract.--Four Indiana bat nursery colonies have been found in riparian habitat. Three used recently dead trees with exfoliating bark and one used a hollow branch. Threats include deforestation and stream channelization. Management recommendations include maintaining riparian forest especially large, recently dead trees; restore riparian forest and implement research on Indiana bat summer habitat.

---

## INTRODUCTION

The Indiana bat is a medium sized member of the genus and closely resembles the little brown bat (Myotis lucifugus). It is a monotypic species that occupies the eastern half of the United States. They hibernate in caves and mines from October to April with large hibernating populations occurring in Indiana, Missouri and Kentucky (Brady et al., In Press). Recent studies indicate that maternity colonies are formed mostly in riparian and floodplain habitat of small to medium-sized streams (Humphrey et al., 1977; Cope et al., 1978; Sparling et al., 1979; Gardner and Gardner, 1980). The maternity colonies that have been found have used dead trees (Humphrey et al., 1977; Cope et al., 1978).

## CAUSES FOR ENDANGERED STATUS

The Indiana bat has been designated an endangered species by the U.S. Fish and Wildlife Service and is protected under the Endangered Species Act of 1973, as amended (U.S. Fish and Wildlife Service, 1978). A recovery plan has been prepared and should be available in late 1983 from the U.S. Fish and Wildlife Service.

The most important reasons for the decline of this species is human disturbance of hibernating bats causing the bats to arouse and use their stored fat supply. Vandalism and alteration of cave entrances, thus changing the cave microclimate, are also important. (Brady et al., In Press)

## SUMMER HABITAT

Three of the known nursery colonies occurred in riparian habitat in east central Indiana. The habitats of the two that occurred along the Big Blue River were described by Cope et al. (1978). Thirty-eight percent of the floodplain was forested including bottomland forest stands as well as strip woods adjacent to the river and pastured woodlots. The following species listed in order of importance made up 90 percent of the riparian trees: Acer negundo, A. saccharinum, Fraxinus sp., Plantanus occidentalis, dead tree, Celtis occidentalis, Ulmus americana, Salix sp., Populus deltoides, Juglans nigra, Gleditsia triacanthos, Aesculus glabra, and Ulmus rubra. Fifty-four percent was cropland with mostly corn and some soybeans, 7 percent was pasture and fallow fields, and 1 percent was ponds. The third maternity colony that was studied and described by Humphrey et al. (1977) was located in similar riparian habitat (Cope et al., 1978).

Cope et al. , (1978) believed that the best foraging habitat is mature riparian forest at least 30 meters wide on both sides of the stream. Indiana bats would not fly over open spaces. The summer habitat was occupied from mid-May to mid-September (Humphrey et al., 1977)

The roost trees of three nursery colonies in east central Indiana have been described (Humphrey et al., 1977; Cope et al., 1978; Brack, Personal Communication). Another nursery colony was reported to have been in the hollow branch of a riparian tree in northwest Missouri (Humphrey et al., 1977).

The nursery colony reported on by Humphrey et al. (1977) first used a dead American elm (Ulmus americana) and moved to a dead bitternut hickory (Carya cordiformis) after the elm was destroyed by land clearing. The colony also used a nearby live shagbark hickory (C.ovata) as an alternate roost. The bats roosted under loose bark on the dead bitternut. Humphrey et al. (1977) believed that alternating between the dead bitternut and live shagbark gave the bats a thermal advantage under different

---

<sup>1</sup>Paper presented at the Snag Habitat Management Symposium (Northern Arizona University, Flagstaff, Arizona, June 7-9, 1983).

<sup>2</sup>John T. Brady is Team Leader of the Indiana/Gray Bat Recovery Team and a wildlife biologist with the St. Louis District Corps of Engineers, St. Louis, Missouri.



weather conditions. He believed that the dead trees were selected because they were more effective in trapping solar radiation since they did not have foliage to block sunlight and had little water to stabilize temperature.

Two other nursery colonies were discovered by Cope et al. (1978) and both occurred in dead cottonwood trees (Populus deltoides) (Cope, Personal Communication). Brack (Personal Communication) described one of these trees as follows:

"The roost tree had several large slabs of loose bark on the major limbs, while the remainder of the bark, both on the limbs and the tree bole, had fallen away. Only six or seven large branches remained on the tree; all the smaller branches were gone. The tree leaned over the river at an angle of about 15° from perpendicular. A typical component of riparian woody species was found on the floodplain near the roost..."

Another important characteristic of summer habitat was the size needed to support a colony. Individual nursery colonies have ranged from 50 bats occupying 0.8 kilometer of stream (Humphrey et al., 1977) to 100 bats occupying 1.2 kilometer (Cope et al., 1978). An average population density for suitable riparian habitat of 75 bats per kilometer has been suggested (Cope et al., 1978).

#### THREATS TO SUMMER HABITAT

Threats to summer habitat include deforestation and stream channelization for agricultural drainage and surface mining (Brady et al., In Press). In Illinois, Conlin (1976) reported that 30 percent of the stream were channelized and, if future plans were implemented, the total would rise to 45.5 percent. Some channelized streams support Indiana bat populations (Brack, 1979; Humphrey et al., 1977) after riparian vegetation has become established. LaVal and LaVal (1980) believed that summer habitat is not presently limiting Indiana bat populations, however, Bowles (1981) warns that clearing can lead to the fragmentation of wooded habitat along streams.

One direct threat to potential roost trees is the increased demand for wood as fuel. Firewood collections on national forests remove snags (Conner, 1978).

#### RECOMMENDATIONS

Riparian forest should be maintained throughout the range of the Indiana bat to the greatest extent practicable. In addition, a number of recommendations have been made in the Indiana Bat Recovery Plan (Brady et al., In Press):

1. Maintain large dead trees. Since a given roost site is believed to be suitable for only

2-8 years (Humphrey et al., 1977; Brack et al., 1982) a constant supply is needed.

2. Restore forest cover to channelized streams and ditches to a width of at least 30 meters on both sides. If possible a stream that is widened should be widened from one side only, leaving the opposite bank natural. Any clearing should be done between 15 September and 1 April to avoid nursery colonies.

3. Maintain water quality, since one of the main food items of Indiana bats is aquatic insects.

4. Locate and investigate more nursery colonies, since only three nursery colonies have been studied.

#### LITERATURE CITED

- Bowles, J.B. 1981. Final Report, 1980-81, Ecological studies on the Indiana bat in Iowa. Iowa Conservation Commission, Des Moines, IA.
- Brack, V. 1983. Personal Communication Department of Forestry and Natural Resources, Purdue University, West Lafayette, IN.
- Brack, V., 1982. Determination of presence and habitat suitability for the Indiana bat (Myotis sodalis) along portions of the Kankakee River, Indiana. U.S. Army Corps of Engineers, Chicago, IL
- Brack, V. 1979. Determination of presence and habitat suitability for the Indiana bat (Myotis sodalis) and gray bat (Myotis grisescens) for portions of three ditches, Big Five Levee and Drainage District, Union and Alexander Counties, Illinois. U.S. Army Corps of Engineer, St. Louis, MO.
- Brady, J. T., T.H. Kunz, M.D. Tuttle, D.E. Wilson, R.L. Clawson, and R.K. LaVal. In Press. Indiana Bat Recovery Plan. U.S. Fish and Wildlife Service, Twin Cities, MN.
- Conner, R.N. 1978. Snag management for cavity nesting birds. Proceedings of the workshop for management of southern forests for nongame birds. Forest Service General Tech. Report SE-14, USDA.
- Cope, J.B., A.R. Richter, and D.A. Searley. 1978. A survey of bats in the Big Blue Lake project area in Indiana. U.S. Army Corps of Engineers. Joseph Moore Museum, Earlham College, Richmond, IN.
- Gardner, J.E. and T.L. Gardner. 1980. Determination of presence and habitat suitability for the Indiana bat (Myotis sodalis) and gray bat (M. grisescens) for portions of the lower 6.6 miles of McKee Creek, McGee Creek Drainage and Levee District, Pike Co., Illinois. U.S. Army Corps of Engineers, St. Louis, Missouri.

Humphrey, S.R., A.R. Richter, and J.B. Cope.  
1977. Summer habitat and ecology of the  
endangered Indiana bat, Myotis sodalis. J.  
Mamm., 58: 334-346.

LaVal, R.K., and M.L. LaVal. 1980. Ecological  
studies and management of Missouri bats  
with emphasis on cave dwelling species.  
Terrestrial Series No. 8, Missouri  
Department of Conservation, Jefferson  
City, MO.

Sparling, D.W., M. Sonsler, and T. Hickman.  
1979. Limited biological assessment of  
Galum Creek. Southern Illinois University,  
Carbondale, IL.

U.S. Fish and Wildlife Service. 1978. List of  
endangered and threatened wildlife and  
plants. Federal Register. 43 (238): 58031,  
11 December 1978.



# The Importance of Snags to Pine Marten Habitat in the Northern Sierra Nevada<sup>1</sup>

Sandra K. Martin and Reginald H. Barrett<sup>2</sup>

---

Abstract. Snags were found to represent 23% of all dens located during a study of pine marten (Martes americana) ecology conducted on the east slope of the Sierra Nevada. Use of snags as den sites by two geographically isolated groups of pine marten occupying dissimilar habitats within the study area was significantly different. Relative levels of snag utilization may be related to the availability of other preferred den types within a specific marten home range.

---

## INTRODUCTION

Heavy trapping pressure and major loss of habitat through fires and logging have been blamed for the extreme reductions exhibited by many pine marten (Martes americana) populations in North America in the past century (Barbant 1922, Yeager 1950). Conservationists in California, alarmed by declines in local marten populations which began as early as 1900, urged the passing of a legislative ban on marten trapping in the state (Taylor 1913, Grinnell et al. 1937). Such a ban was enacted in 1953 and remains effective to date. By the 1970's, casual and intermittent information suggested that marten populations had regained a healthy status wherever semi-secluded tracts of appropriate forest habitat were found in the state, but few detailed studies of marten in California existed (Schempf and White 1977). In 1979, University of California personnel, in cooperation with the U.S. Forest Service, undertook long-term investigations of pine marten ecology. The data presented below are part of this larger study.

## METHODS

The study was conducted in a 40 km<sup>2</sup> area defined by the upper watershed of Sagehen Creek, located on the east slope of the Sierra Nevada in the Truckee Ranger District, Tahoe National Forest, California. Elevations in the study area range from 1880 m in the east to 2620 m on the western edge, 5 km from the Sierra Nevada crest. Major habitat types in the watershed include those defined by meadow/fen/lodgepole pine (Pinus contorta) complexes in riparian zones at lower elevations. Drier forests dominated by Jeffrey pine (Pinus jeffreyi) are found on south-facing

slopes. The Jeffrey pine stands mix with white fir (Abies concolor) at higher elevations. Red fir (Abies magnifica) becomes prevalent on even higher mountain slopes.

Field work from which data below were extracted began in June 1981 and continues to date (June 1983). Pine marten were livetrapped in 20 x 20 x 60 cm Tomahawk traps baited with fish and commercially prepared scent. The traps were placed at stations on a 200 x 600 m grid. Trapped marten were drugged with ketamine and acepromazine for handling, and a radio collar was placed on each marten.

Radio collared marten were located once daily with radio receiving equipment and hand held antennas. Marten were tracked to their precise locations. Active marten could often be sighted at a distance while being followed, and the dens of inactive marten could be directly approached.

Habitat was characterized by collecting data regarding the vegetation on 0.1 acre (0.25 ha) circular plots. Plot centers were placed using the marten trapping grid described above. Data collected included tallies of all deadwood features on the plots. Deadwood was interpreted as comprising all snags, stumps, and logs. Specifically, a snag was tallied when found to be greater than 20 cm in diameter at breast height (DBH) and taller than 2 m. A stump was counted if it was at least 20 cm wide at its highest point. A stump was defined as being less than 2 m tall. A log was counted on the plot when it was at least 40 cm wide at a point 1.5 m above its base, at least 2 m long, and at least half of the log lay on the plot.

Data used below to estimate densities of deadwood features in different subregions of the study area were taken from habitat plots located within the home ranges of radio collared pine marten. Den sites were tabulated for eight individual marten (four ♂: four ♀). Only dens found at least 24 hours apart during tracking were counted. For instance, five locations of the

<sup>1</sup>Paper presented at the Snag Habitat Management Symposium (Northern Arizona University, Flagstaff, Arizona, June 7-9, 1983).

<sup>2</sup>Authors' address; Dept. of Forestry and Resource Management, University of California, Berkeley, Ca. 94720



same marten in the same den in a single 24 hour (midnight to midnight) period would be tabulated as one den site location.

Relationships between marten sex and den type, and between geographic location of marten dens and den type, were examined with the 2 x 2 test of independence using the G-statistic (Sokal and Rohlf 1969: 591-92). A Student's t test, modified to account for  $\sigma_1^2 = \sigma_2^2$ , was used to compare average densities of habitat components in two different subregions of the study area (Cochran 1964).

## RESULTS

Pine marten investigated in this study typically occupied a den for periods ranging from one to seven days. They remained inactive within the den for several hours at a time, often leaving to hunt and returning later. Marten are usually solitary except during brief mating liaisons in summer. Another social grouping forms when kits stay with their mother from birth in early spring until late summer. Members of these social groups often occupy the same den simultaneously.

A common movement pattern identified was for a pine marten to occupy a den for one or two days, then shift to another den within a few hundred meters of the first. Another shift would occur a day or two later. Dens within one specific area of the home range were often used for a few weeks, with the marten then completely shifting activity and den occupation to another area of its home range. Specific den sites were often used again after the initial occupation. Home ranges of the pine marten overlapped to varying degrees, and some sites were used by two or even three individuals at different times.

Types of den sites included the following categories: snags, stumps, logs, the canopy of trees, willow (*Salix* spp.) clumps, other brush, rock slides, and subnivean dens of unknown structure. Snags represented 23% of all den sites found (n=250). When only those dens used more than once were considered, snags were found to incorporate 27% of the total (n=90).

Dens were divided into the categories "snags" and "other dens". Den type was then found to be independent of the sex of the occupying marten ( $G=0.301$ ,  $\chi^2_{\alpha=0.05, d.f.=1}=3.841$ ). Marten den locations were also divided into two geographic categories; those of marten located in the western half of the study area, above 2250 m elevation (upper basin marten), and those found in the eastern end of the watershed (lower basin marten). The independence of snag and non-snag dens was tested with these two geographic categories. The null hypothesis of independence was rejected ( $G=7.268$ ,  $\chi^2_{\alpha=0.05, d.f.=1}=3.841$ ). Specifically, marten in the lower basin area used proportionally more snags as dens than did upper basin marten (table 1).

Snag densities for each of these two geographic areas were taken from habitat plots within

Table 1. Den types used by pine marten in the upper and lower subregions of Sagehen Creek Watershed.

	Upper Basin	Lower Basin
Total number of den sites located	165	85
Number of snag dens	29	28
Percent of total	17.6	32.9
Number of deadwood dens	121	49
Percent of total	73.3	57.6

the designated areas. Mean snag densities were 10.74/acre (26.54/ha) in the lower basin (below 2250 m elevation) and 8.78/acre (21.70/ha) in the upper basin (table 2). Using a modified t test, no significant difference between these two means was found (test statistic=0.699,  $t'=1.674$ ).

Deadwood dens (snags, stumps, and logs) pooled together represented 68% of all marten den sites. As with snag dens alone, the hypothesis of independence between geographic location (upper and lower basin) and den type (deadwood and other dens) was rejected ( $G=6.224$ ,  $\chi^2_{\alpha=0.05, d.f.=1}=3.841$ ). Marten

in the upper basin were found to be using proportionally more deadwood dens than those in the lower basin (table 1).

Densities of stumps and logs in the two geographic areas were obtained in the same manner that snag densities were calculated. Modified t tests indicated that stump density in the upper basin was significantly higher than that in the lower basin (test statistic=2.32,  $t'=1.680$ )(table 2). A similar result was found when log densities in the upper and lower basin areas were compared (test statistic=3.0,  $t'=1.671$ )(table 2).

## DISCUSSION

Snags are an important habitat component for pine marten in the Sagehen Creek watershed. One quarter of all den sites located for eight radio collared marten were in snags. The sex of marten appears irrelevant to discussions of den type selection. Geographic location, i.e. separating marten found in the upper or lower elevations of the study area, had a significant effect on analysis of den type selection. This geographic separation is justifiable on two counts; the categories represent two completely divided groups of marten occupying dissimilar habitat. Home ranges of the four marten found in the lower basin overlap extensively, but none of these overlap with home ranges of any upper basin marten. A similar situation exists among the four upper basin marten. Marten in the lower basin occupy lodgepole pine/white fir forests. Those in the upper basin are found in red fir/white fir forests.

Marten in the lower basin used snags proportionally more than did upper basin marten. However,



Table 2. Average densities of deadwood features in the upper and lower subregions of Sagehen Creek Watershed.

	Snags per acre			Snags per hectare	Stumps per acre			Stumps per hectare	Logs per acre			Logs per hectare
	n	$\bar{x}$	$s^2$		n	$\bar{x}$	$s^2$		n	$\bar{x}$	$s^2$	
Upper Basin	41	8.78	170.98	21.70	41	16.10	169.39	39.78	41	13.17	197.20	32.62
Lower Basin	27	10.74	99.43	26.54	27	8.89	148.72	21.97	27	4.44	94.87	10.87

snag densities appear to be similar in these two areas. Marten in the upper basin used more deadwood dens overall than did marten in the lower basin. These facts appear somewhat contradictory, but when stump and log densities in the two subregions are compared, a probable explanation emerges. The upper basin habitat provides a greater number of stumps and logs as possible den sites for marten than can be found in the lower basin. Marten are opportunistic, to a degree, in den selection. Deadwood sites provide preferred den locations, but where densities of snags, stumps, and logs are not high, other habitat features are utilized.

Snags probably gain importance as marten den sites in areas where logging has not recently occurred, or where stump and log densities are naturally low. A history of timber harvest activities in the Sagehen Creek basin reveals that extensive logging occurred at lower elevations between 1900-1920, and that a timber sale in 1967 resulted in strip-cut harvests in the upper basin (West 1982). The logging operation of 16 years ago is the most likely reason for the current high log and stump densities found in the upper basin.

Further analyses of den characteristics are being undertaken, and may disclose the importance of features beyond simple availability in marten den selection. Characteristics of suspected significance include size (DBH, height, and length), state of deterioration, proximity and amount of overhead canopy cover, and clustering of acceptable dens.

Snags should be respected as potential den sites in all areas where the marten occurs. However, snags are particularly important where logging has not been common. The natural decay of snags would

also be a primary factor in providing stumps and logs for marten dens in such undisturbed habitat.

#### LITERATURE CITED

- Brabant, A. 1922. The fire fiend's threat to the fur trade. *Illustrated Can. For. Mag.* 18(12): 1204-1205.
- Cochran, W. G. 1964. Approximate significance levels of the Behrens-Fisher test. *Biometrics* 20: 191-195.
- Grinnell, J., J. S. Dixon, and J. M. Linsdale. 1937. *Fur-bearing mammals of California*. 375 p. Univ. of Calif. Press, Berkeley, Calif.
- Schempf, P. F. and M. White. 1977. Status of six furbearer populations in the mountains of northern California. 51 p. USDA Forest Service, San Francisco, Calif. (unnumbered publication)
- Sokal, R. R. and F. J. Rohlf. 1969. *Biometry*. 776 p. W. H. Freeman and Co., San Francisco, Calif.
- Taylor, W. P. 1913. Fur-bearing mammals; an unappreciated natural resource. *Science* 37: 485-487.
- West, C. I. 1982. Management options for the Sagehen Creek basin. 110 p. M. S. F. Prof. Pap., Univ. of Calif., Berkeley.
- Yeager, L. E. 1950. Implications of some harvest and habitat factors on pine marten management. *Trans. N. Am. Wildl. Conf.* 15: 319-334.



# Seasonal Selection of Tree Cavities by Pygmy Nuthatches Based on Cavity Characteristics<sup>1</sup>

Douglas B. Hay<sup>2</sup> and Marcel Güntert<sup>3,4</sup>

---

Abstract.--Eighteen characteristics of 46 cavities used seasonally by Pygmy Nuthatches were compared to determine factors influencing cavity choice. Seasonally used cavities differed significantly in from 1-5 characteristics. Snag management should provide for seasonality in snag/cavity quality and bird choice.

---

## INTRODUCTION

The importance of snags and dead wood within live trees to populations of secondary cavity nesting birds is well documented (eg. Allen and Nice 1952, Balda 1975, Cunningham et al. 1980). Further support for their value has been obtained where cavity density was increased by the supply of nest boxes (eg. von Haartman 1957). Several investigators have offered management proposals of a minimum number of snags necessary to maintain populations of secondary cavity nesters (SCNs) (eg. Balda 1975). Silviculture practices have begun to incorporate these recommendations.

A basic assumption in most present management plans is that a sufficient quantity of snags of a minimum size will provide cavity nesters (both primary and secondary) with suitable nest sites. Yet to the birds a snag may not be a snag; a cavity may not be a cavity. Variation in the macro- and/or microhabitat of the snag or cavity may affect the suitability of the site for a nest. Furthermore many SCNs are resident species and may select different cavities as nocturnal roost sites (Cunningham et al. 1980). These species, more correctly classified as secondary cavity users (SCUs) may take advantage of a cavity's qualities seasonally at which time the site is preferred.

The most common permanent resident SCU in coniferous forests of western North America is the Pygmy Nuthatch (*Sitta pygmaea*). The species is unique in that it roosts communally in tree cavities normally in groups of 10-14 birds (Güntert

unpub.). This pattern is observed throughout the year, with the exception of the nesting period. Pygmy Nuthatches are further known to select different cavities for nesting and winter roost sites (Cunningham et al. 1980). Güntert (unpub.) has identified summer and fall/spring roosts as well.

The objectives of this study were: 1) to determine characteristics which distinguish those cavities preferred within a season by Pygmy Nuthatches, 2) to identify the possible benefits of those cavity characteristics selected within a season, and 3) to outline important considerations for the future management of habitat for Pygmy Nuthatches and other SCUs.

## STUDY AREA

The study area was located within 3.4 km of the canyon rim at Walnut Canyon National Monument, Coconino County, Arizona. Ponderosa pine was the predominate vegetation type in the area. Mature pine stands with high snag densities characterize the community within the monument. North of the monument boundary in Coconino National Forest land logging and fuel wood collecting have removed virtually all snags and have greatly reduced foliage volume. Forest Service road 303 separates the two jurisdictions.

## METHODS AND MATERIALS

Characteristics of 46 cavities used seasonally by banded flocks of Pygmy Nuthatches were recorded. Cavities were assigned to general seasonal categories (eg. nests, summer roosts, winter roosts, and fall/spring roosts) according to observed use by the birds.

Fourteen characteristics were used to discriminate between seasonal cavity usage groups. The total tree height, DBH, and general condition were recorded for the tree containing the cavity. The height to the cavity and diameter of the trunk or branch surrounding the cavity were recorded.

---

<sup>1</sup>Paper presented at the Snag Habitat Management Symposium (Northern Arizona University, Flagstaff, June 7-9, 1983).

<sup>2</sup>Douglas B. Hay is Instructor of Biological Sciences, Northern Arizona University, Flagstaff.

<sup>3</sup>Marcel Güntert is Research Associate, Northern Arizona University, Flagstaff.

<sup>4</sup>Present address is Museum of Zoology, University of Zurich, Switzerland.



Measurements were taken of cavity depth, width, vertical length, entrance hole area, and accessory holes. The hole's direction of orientation and placement were noted. Cavity placement (branch, trunk) and angle (of the branch) were also noted.

Cavity volume was directly measured in over 90% of the cavities. A vacuum hand pump was used to fill an elastic reservoir (condom) located within the cavity. When the cavity space was filled the pump was removed and the water within was measured in a 500cc graduated cylinder. Cavity volumes which could not be measured in this way were estimated from inside dimensions.

Daily radiation absorbed by the cavities was calculated for four representative days of the year. A series of four clinometers were constructed, enabling the observer to trace the arc of the sun on February 15, April 15, June 15, and August 15, regardless of the date of data collection. The time and degree of cover which would obstruct direct insolation were noted by the observer for each date. Data was called out to an individual recording the information on the ground. Qualitative cover categories of clear sky, light shade, medium shade, and heavy shade were used. Tabulated values of direct radiation were corrected for shade periods by reducing the values by 20, 40, and 60% for light, medium, and heavy shade, respectively. These percent reductions were determined from the measurement of qualitative shade classes on the penetration of radiation recorded by a light meter. Indirect solar radiation was calculated as a time and date specific percentage of the direct solar radiation penetrating the atmosphere on a clear day (Gates 1980). Calculations of daily absorbed radiation were made using Morhardt's (1975) equation:

$$Q = (A \cdot SA)DR + 0.5((A \cdot IR) + A \cdot R(DR + DI))$$

where A = absorbtivity, SA = radiated surface area or ((cavity length/cavity diameter)/cosine of the angle of the sun), DR = direct radiation, IR = indirect radiation. Calculations were made using a specifically designed computer program, which corrected for shade.

Differences between characteristics of seasonal cavities were evaluated by two methods. Mean values of recorded characteristics of nests, summer roosts,

fall/spring roosts, and winter roosts were tested for significance using two-sample t-tests. A discriminant analysis was employed to determine those characteristics most important in distinguishing between seasonal usage groups. In this test fall and spring roosts were split into fall roosts and those cavities used in both the fall and the spring. Nests used through the summer and fall were also assigned to a specific group. Each cavity was assigned to only one of the usage groups.

## RESULTS

Statistical comparisons between mean characteristics of seasonal cavity groups indicated nest cavities were most distinctive (Table 1). Nest cavities are significantly lower in the tree than summer roosts (SR), fall and spring roosts (F/S), and winter roosts ( $t=2.29$ ,  $.010 < p < .025$ ;  $t=3.88$ ,  $p < .005$ ;  $t=3.25$ ,  $p < .005$ ; respectively). SR, F/S, and winter roosts were located in significantly taller trees ( $t=2.57$ ,  $.010 < p < .025$ ;  $t=5.34$ ,  $p < .005$ ;  $t=3.62$ ,  $p < .005$ ; respectively). Nests averaged smaller entrance holes than SR and F/S roosts ( $t=1.75$ ,  $.025 < p < .05$ ).

Fewer characteristics distinguished between winter, SR, and F/S roosts. Winter roosts differed in having significantly smaller entrance holes than SR and F/S cavities ( $t=44.8$ ,  $p < .001$ ;  $t=42.8$ ,  $p < .001$ ; respectively). F/S roosts were located higher in the tree than SR roosts ( $t=2.08$ ,  $.025 < p < .05$ ).

Cavities were usually located in the trunk of snags or lightning strikes or dead branches of live trees. The majority of nests and winter roosts were located in trunks (Table 2). SR and F/S roosts were distributed somewhat evenly between trunks and branches.

Calculations of average daily absorbed radiation indicated a wide degree of variation within a seasonal usage group (Table 3). Comparisons of mean absorbed radiation were only significantly different between SR and F/S roosts ( $t=2.95$ ,  $.005 < p < .010$ ). This difference occurred in the Spring (April 15) during which time F/S roosts absorbed more radiation.

Table 1.--Mean values of characteristics of seasonally used cavities.

	Tree		Cavity						Hole			
	height	DBH	height	diameter	depth	width	length	volume	accessory hole area	area	azimuth	
	(m)	(cm)	(m)	(cm)	(mm)	(mm)	(mm)	(cc)	(cm <sup>2</sup> )	(cm <sup>2</sup> )		
Nests	$\bar{X}$	9.8	39.2	5.6	25.2	63.8	73.1	147.1	528.9	5.0	13.0	109.5
(n=10)	SD	5.8	20.0	2.1	18.3	22.5	29.5	76.8	150.5	1.2	0.9	91.1
SR	$\bar{X}$	18.9	64.5	7.9	22.0	73.5	73.4	148.2	630.2	36.0	22.2	160.5
(n=11)	SD	9.9	19.5	2.5	11.5	19.7	30.9	70.2	374.6	85.6	15.1	112.1
F/SP	$\bar{X}$	24.5	63.3	10.8	34.9	75.6	68.1	172.6	616.2	1.5	21.7	161.8
(n=9)	SD	6.1	17.3	3.5	26.1	24.0	13.4	24.9	226.8	0.4	14.0	130.7
Winter	$\bar{X}$	23.2	73.1	9.3	56.6	73.2	68.7	137.2	683.1	3.6	11.2	188.2
(n=8)	SD	9.1	20.3	2.6	22.6	21.6	18.9	44.5	393.5	0.5	6.0	58.6



Table 2.--Location of seasonal cavities (%).

	Trunk	Branch
Nests (n=10)	91.7	8.3
SR (n=11)	45.5	54.5
F/SP (n=9)	66.6	33.3
Winter (n=8)	87.5	12.5

Table 3.--Mean daily absorbed radiation of seasonally used cavities(Langleys/day).

		Breeding (Jun 15)	Summer (Aug 15)	Spring (Apr 15)	Winter (Feb 15)
Nest	$\bar{X}$	2625	5470	5939	601
	SD	1695	2402	2527	316
SR	$\bar{X}$	3392	6197	6176	925
	SD	694	1980	2909	339
F/SP	$\bar{X}$	7061	10957	14265	1504
	SD	7179	8983	9134	1229
Winter	$\bar{X}$	4727	7057	6937	989
	SD	4680	7114	5654	957

A discriminant analysis was made to differentiate between six seasonal usage groups. These groups were nests, summer roosts, fall roosts, nests used during the summer and fall of the same year, winter roosts (usually used during other seasons), and fall and spring roosts. Eight variables were found to be significant in explaining the variation between groups: tree height (TH), DBH, height of cavity in the tree (CH), diameter of the trunk or branch surrounding the cavity (DC), cavity length (CL), accessory hole area (AHA), compass orientation of the hole (HAZ), and density of the wood (D).

On the basis of these eight characteristics nests were found to be significant from all groups except nests also used in the summer and fall (Table 4). Summer roosts were significantly different from all other groups, except for those cavities used only in the fall. All other seasonal usage groups were insignificantly different from one another.

Three discriminant functions were used in the analysis. CH, AHA, DBH, and TH were included in the first function. The second discriminant function was based on DC. CH, HAZ, and D identified the third function. Together these functions correctly classified 65% of the 46 cavities.

Table 4.--Significance between groups as defined by discriminant analysis (n=46).

		Nests	SR	Fall	N,SR,F	Winter
SR	F	3.99				
	P	.00				
Fall	F	2.52	1.70			
	P	.02	.13			
N,SR,F	F	1.68	2.73	1.23		
	P	.13	.01	.30		
Winter	F	3.10	2.21	1.15	2.00	
	P	.01	.05	.35	.05	
F/SP	F	2.15	2.16	1.31	1.09	0.91
	P	.05	.05	.27	.39	.51

#### DISCUSSION

Several characteristics of the macrohabitat distinguished between cavities used seasonally. Trees housing nest cavities were shorter and consequently had a significantly smaller DBH. The selection of these smaller trees and lower cavities within them probably represents a response to wind. By utilizing cavities closer to the ground convective heat loss may be greatly reduced. Greater cavity height of Fall/SP roosts in comparison to SR was identified in more absorbed spring/fall radiation by the prior. In contrast nest cavities appear to be positioned to obtain moderate insolation, while being shielded from wind. Average radiation absorbed by nests was not significantly different from that calculated for any other cavity group during the breeding season.

A variety of microhabitat variables were useful in differentiating seasonal cavities. Entrance hole area and the area of other accessory holes both are important factors affecting the physical movement of air through the cavity (Hay unpub.). Larger hole areas and smaller cavity lengths increase the relative air flux. In addition the greater the relative difference in outside ambient temperature vs. inside (roost) temperature the more rapid the air movement. Selection of cavities with large entrance areas during periods of time when temperature differences are small and the birds are communal (Summer and Fall/Spring) encourages greater air flux. During much of the nesting period fewer birds are roosting together. Generally one to six nights after fledging the family switches to a SR (Guntert, unpub.). Winter temperature differences are high offsetting the negative effect of a smaller hole size on the mass transfer of air.

The location of more SR and Fall/SP roosts in branches may further aid communal birds to acquire adequate ventilation. Slanting branches allow individuals to position themselves closer to the cavity entrance, without the extra energy required to cling to the walls of vertical cavities.



Other characteristics distinguishing the microclimate were identified as significant in the discriminant analysis. The diameter of the trunk or branch at the cavity as well as cavity density and compass orientation at the entrance (azimuth) appear related to seasonal needs for convective and radiant heat gains or losses by the cavity. Bigger cavities with holes oriented more to the south may heat up more in the winter and be on the lee side of trees when northerly winds blow. Nest cavities facing east will warm faster in the mornings and be more protected by prevailing westerly winds. Less dense wood in nests and winter roosts buffers the cavities from rapid temperature shifts.

On the basis of these and other significant factors the discriminant analysis was unable to classify 35% of the 46 cavities correctly. However of those incorrectly classified 95% are located in the section of the study area which has been logged and heavily cut for fuel wood. This strongly suggests that alteration of the birds' habitat, resulting in considerable reduction in snag densities, forces Pygmy Nuthatches to use atypical cavities. Cavity selection appears strongly tied to a variety of seasonal behavioral and physiological responses of the birds (Hay, unpub.). The management practices of snags which do not provide an adequate range in snag and/or cavity quality may affect the overall biology of the species, its survivorship, and reproduction.

#### CONCLUSIONS

Seasonal cavities selected as nest and/or roost sites by Pygmy Nuthatches were found to differ in several characteristics. These factors contribute to interseasonal variation in the macro- and/or microhabitat of the cavity. In the absence

of an array of cavities from which to choose, the birds are forced to use atypical cavities within a season. As cavity selection is interrelated to the overall biology of the species, management of snag and/or cavity quality, rather than quantity, appears critical. We recommend more baseline research of this type conducted with the goal of determining important cavity characteristics for seasonal usage by resident secondary cavity users.

#### LITERATURE CITED

- Allen, Robert R. and Margaret M. Nice. 1952. A study of the breeding biology of the purple martin (*Progne subis*). *American Midland Naturalist* 47: 606-665.
- Balda, Russell P. 1975. The relationship of secondary cavity nesters snag densities in western coniferous forests. U.S.D.A. Forest Service Wildlife Habitat Technical Bulletin 1, 37 p. Southwestern Region, Albuquerque, New Mexico.
- Cunningham, James B., Russell P. Balda, and William S. Gaud. 1980. Selection and use of snags by secondary cavity-nesting birds of the ponderosa pine forest. U.S.D.A. Forest Service Research Paper RM-222, 15 p. Rocky Mountain Forest and Range Experiment Station, Fort Collins, Colorado.
- Gates, David M. 1980. *Biophysical ecology*. 611 p. Springer-Verlag, New York.
- Haartman, Lars von. 1957. Adaptation in hole nesting birds. *Evolution* 1: 339-347.
- Morhardt, Sylvia S. 1975. Use of climate diagrams to describe microhabitats occupied by Belding Ground Squirrels and to predict rates of change of body temperature. In *Perspectives of Biophysical Ecology* (ed. D. M. Gates and R. B. Schmerl) pp 303-324. Springer-Verlag, N.Y.





# Winter Communal Roosting in the Pygmy Nuthatch<sup>1</sup>

William J. Sydeman and Marcel Güntert<sup>2</sup>

---

Abstract.--We have studied the communal roosting behavior of Pygmy Nuthatches in one extremely important cavity in a snag. Between 27 and 167 birds used the roost during the winter of 1983. Some nuthatches moved almost 2 kilometers nightly to reach this cavity. The number of birds and time of roosting were effected by weather conditions.

---

## INTRODUCTION

Cavities in snags provide essential habitats for birds during many phases of their life histories. For migratory species, cavities provide the proper thermodynamic and protective environments for rearing young. Resident species may use cavities for predator avoidance and energy requirement during the non-breeding season as well. In particular, the survivorship of many over-wintering species may depend solely on their use of snags. The importance of snags may be underestimated with regards to the survivorship of many forest dwelling birds.

The Pygmy Nuthatch (*Sitta pygmaea*) relies on cavities during the winter for survival. Pygmy Nuthatches are one of the smallest (10-11 grams), resident birds of the Ponderosa Pine (*Pinus ponderosa*) forest near Flagstaff, Arizona. They are highly social, and live in groups of 5-20 individuals throughout the non-breeding season. In winter, nuthatches forage in flocks of 4-20 or more that jointly defend a group territory from conspecifics. In the late afternoon, birds gather and travel to a snag within their territory to spend the night. These communal roosts vary in volume and number of birds using them. The snag, where a communal roost is located, is the central focus of wintering birds (Norris, 1958). The largest reported roost of Pygmy Nuthatches is that of Knorr (1957), who estimated 150 birds using a snag in a montane area of Colorado.

Here we report on the communal roosting behavior of a large population of Pygmy Nuthatches in one particularly important snag during the winter of 1983. We will examine the biotic and abiotic

factors that play a role in promoting large roosting aggregations. Additionally, we will describe the distances traveled by nuthatches to reach this cavity, and the composition of this roosting association in terms of foraging flock membership.

## METHODS

We have been studying Pygmy Nuthatch social organization and breeding biology at Walnut Canyon National Monument and in adjacent Coconino County Forest Service land since October, 1980. The study area is approximately 300 ha., 24.0 km. east of Flagstaff, and is dominated by mature stands of Ponderosa Pine with occasional patches of Pinyon Pine (*Pinus edibilis*), Juniper (*Juniperus* spp.) and Gambel's Oak (*Quercus gambelii*). Many snags are available to the birds in the National Monument, whereas few are present in the Forest Service land due to firewood cutting practices.

A large percentage of birds within this area have been color-banded to follow individual life histories. Nuthatches were banded with a unique color-combination. Group foraging territories have been mapped as a result of afternoon observations on the number of birds and identity of individuals in each group.

At approximately 1500-1600 hours, observations began at Walnut Canyon 50 (hereafter WC50), the communal roosting snag used extensively in 1983. The arrival of nuthatches was recorded for as many nights as possible from 14 January to 9 April, 1983. Generally, two well-trained observers participated in gathering data on the number of birds, and on the identity of individuals. Nuthatches were viewed entering the cavity using either a Bushnell Spacemaster or a Bausch and Lomb Explorer spotting scope(s).

We restricted our analyses to evenings when only a full complement of the data were obtained. For example, only those evenings when a full count was made on the number of birds roosting were used for statistical analysis. Similarly, only those nights when we were certain to have arrived before

---

<sup>1</sup>Paper presented at Snag Habitat Management Symposium. Northern Arizona University, Flagstaff, Arizona, June 7-9, 1983.

<sup>2</sup>William J. Sydeman is a graduate student in the Department of Biological Sciences, Northern Arizona University, Flagstaff, AZ, and Dr. Marcel Güntert was a post-doctorate student at NAU. Presently, Dr. Güntert is Professor of Anatomy, Universität Irchel, Zurich, Switzerland.



any birds had entered the roost were used in the analysis of time of roosting.

All regression models were developed using SPSS forward or stepwise procedures.

## RESULTS

### Number of Birds and Time of Roosting

A total of 33 accurate evening counts were made on the number of birds roosting in WC50. The count varied considerably with a high of 167 on 19 February and a low of 27 on 10 March (fig. 1).

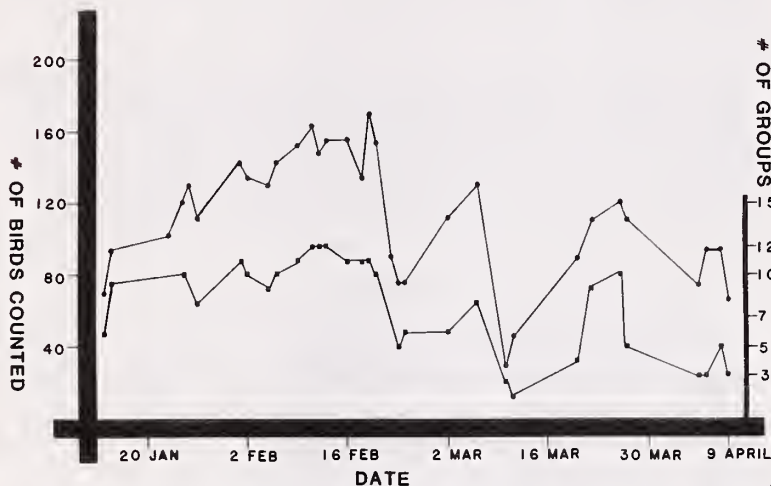

FIGURE 1. NUMBER OF BIRDS AND GROUPS COUNTED NIGHTLY

Figure 1.--Number of birds (left y-axis) and number of banded group (right y-axis) observed each night coming to WC50.

A steady increase in the number of roosting birds and the number of banded groups coming to roost is apparent from the beginning of the study through the first three weeks of February. Subsequently, the number of roosting birds dropped and peaked until the middle of April. These data suggest that roosting is a group phenomenon, and that the decision of where to roost is carried out as a group function, and not by individual birds. In addition, the consistent use throughout early February followed by a sudden decrease in numbers within a matter of days suggests that nuthatches are behaviorally tracking changes in environmental conditions. A threshold temperature or weather condition may trigger use of this snag as a roost.

Multiple regression analysis reveals that weather conditions do indeed affect the number of roosting birds. The presence of snow is the best predictor of cavity use and accounts for 26% of the variability in roosting numbers (Table 1). Temperature, barometric pressure and day in the winter cycle contribute an additional 10% in explaining the number of roosting individuals. Other predictor variables that were entered and found to be insignificant are minimum nighttime temperature, relative humidity, wind speed, cloud cover, and changes in barometric pressure. The full model explains only 36% of the variation in roosting

numbers. This is insufficient in describing the observed roosting association. Either additional data are needed on the effect of weather parameters on nuthatch roosting behavior, or biological factors, possibly social constraints, play a role in maintaining large numbers of roosting birds.

Table 1.--Analysis of Variance Table for the Regression of the No. of Birds Counted Nightly with Weather Conditions (n=33).

Source	df	R <sup>2</sup>	F	Signif.
Presence of Snow	1	.26	10.66	p < .005
Maximum Daily Temp.	1	.29	6.05	p < .01
BP @ 1700	1	.33	4.77	p < .01
Day	1	.36	3.89	p < .025
Residual	28			

Data presented with the addition of each variable listed.

Weather conditions not only affected the number of birds using this snag, they were important determinants of the initiation of roosting. Temperature at 1700 hours and the presence of snow account for 54% of the variation in roosting times (Table 2). Temperature is positively correlated ( $r = .71$ ,  $p < .0005$ ) with the time of roosting. On days when the temperature at 1700 hours was higher, the birds roosted later. Snow was negatively correlated ( $r = -.61$ ,  $p < .0005$ ). When snow covered the ground, birds roosted at an earlier time. A confounding effect is seen with day in the winter cycle which contributes an additional 16% to the model. As would be expected, daylight hours lengthened following the winter solstice, and the birds entered the roost at later times. The full model in this case predicts accurately when birds go to roost. From these data, it does appear that temperature and snow change Pygmy Nuthatch roosting behavior.

Table 2.--Analysis of Variance Table for the Regression of the Time of Roosting with Weather Conditions (n=33).

Source	df	R <sup>2</sup>	F	Signif.
Temp. @ 1700 hrs.	1	.50	31.319	p < .0005
Day	1	.66	29.159	p < .0005
Presence of Snow	1	.70	22.985	p < .0005
Residual	29			

Data presented with the addition of each variable listed. Regression Equation:  $Y = 1405.43 + 5.35 (\text{Temp. @ 1700}) + 1.01 (\text{Day}) - 37.28 (\text{SnowP})$ .

### Roosting Composition

The roost contained not only banded, but also many unbanded individuals. The number of banded and unbanded birds in each group, and the distance traveled by each flock to the communal roosting snag are summarized in Table 3. Most of the groups



Table 3.--Characteristics of Foraging Flocks of Pygmy Nuthatches.

Group	No. Banded	No. Unbanded	Total No.	Distance to WC50 (km.)
LB-east	9	3	12	0.664
Or	5	3	8	0.715
LB-west	6	9	15	0.859
DB-8	2	0	2	0.952
Y-east	2	2	4	0.974
Y-west	6	2	8	1.046
LG-west	5	5	10	1.176
DB-east	6	3	9	1.248
LG-east	11	2	13	1.256
Mauve	9	5	14	1.429
Red	8	12	20	1.509
White	9	3	12	1.682
Park-west	1	13	14	0.332

have at least 50% of their birds banded. All banded groups were located east of WC50. The distance traveled to the roost varied from .3 km. to 1.7 km. A total of 141 birds were monitored by taking observations on these banded foraging flocks. At least 79 of these birds were banded and 62 were unbanded. On 19 February, when the highest count of 167 birds was obtained, 96 unbanded birds were observed. Thus, in addition to our banded flocks, other groups of nuthatches from outside the study area were using WC50. The number of these groups is unknown, but the distance traveled to this snag was probably similar to those groups located to the east.

All of the banded flocks have been observed roosting at WC50. Banded birds whose complete color-band combination was determined comprised approximately 50% of all banded birds observed. Figure 2 shows the percent contribution of each banded group. It is clear that certain groups

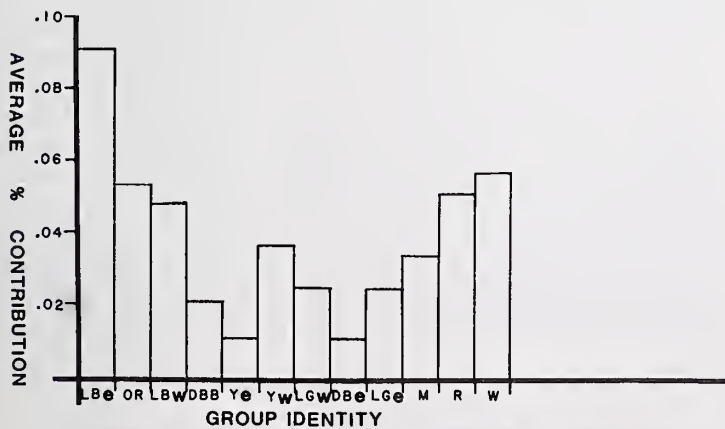

FIGURE 2. PERCENT CONTRIBUTION OF BANDED GROUPS

Figure 2.--Percent contribution of each banded flock to the roosting association. Contribution is computed using only banded birds. Groups are listed in order from the closest to the furthest from the roosting snag.

contributed more to the roost than others. Generally, these were groups closest to the roosting snag. Light Blue-east and west and Orange compose the core groups of the WC50 roosting association. White and Red, whose territories are 1.7 and 1.5 km., respectively, from the roost, exhibited similar contributions to the cavity as did these closer groups. The Light Green and Dark Blue groups contribute least, although their presence at the roost is consistent. Yellow-east and west and Mauve contribute significantly to the roost and their distances range from .9 km. to almost 1.5 km.

#### Cavity Characteristics

WC50 is located in a dying Ponderosa Pine 78 feet above ground. The cavity has two entrances at equal heights, and located on the underside of broken-off branches where they intersect the trunk. One entrance faces to the northeast, while the other has a southwest exposure.

Exact cavity characteristics have not been taken owing to the height of the entrances. However, we can estimate the total volume and surface area needed to accommodate the maximum number of birds counted by extrapolating data collected on another previously measured winter roosting cavity. One particular cavity measured 1500 cc. and held, when packed, a maximum of 42 birds (D. Hay, pers. comm.). These nuthatches, in order to fit into this cavity, must have been stacking on top of one another. Stacking has been observed in aviary birds by groups of 4-12 individuals (D. Hay, pers. comm.). If the birds using WC50 stack, then a minimum of four times 1500 cc. must be available to fit the 167 birds observed roosting on 19 February, 1983. Therefore, the cavity must be at least six liters.

A more realistic assumption may be that the birds are not stacking, but are clinging to the walls of the cavity. An estimate of minimum surface area would then be appropriate in determining cavity size. The area needed to accommodate the ventral surface of a Pygmy Nuthatch is approximately 30 cm<sup>2</sup>. Taking our high count of 167 birds, this means that a minimum surface area of 5,010 cm<sup>2</sup> is necessary. A measurement of this magnitude is equivalent to a bit more than .5 m<sup>2</sup>.

#### DISCUSSION

The use of WC50 has increased dramatically this year over previous winters. Traditionally, only Light Blue-east and west, Yellow-east and west and Orange have used WC50 as a winter roost. Why have these additional flocks joined the roosting association at WC50 this year? This is especially puzzling considering that many winter cavities used by these new groups in previous years are still intact. We have already shown how weather changes affect the number of roosting birds. These data, unfortunately, are insufficient in explaining the total variation in roosting numbers. Since these data are preliminary, we cannot explain fully the increased use of this cavity.



There are, however, a number of theoretical hypotheses in reference to birds roosting in trees or in open areas that may provide some insight into communal roosting by the Pygmy Nuthatch. Lack (1968) proposed that communal roosts function to protect individuals from predators; certain birds roosting in the center of the group may be buffered by peripheral birds when a predator attacks. Ward and Zahavi (1973) have been proponents of the information-center hypothesis which is based on a differential in foraging success between individual birds. Communal roosts then function in the sharing of food localities or foraging techniques between less successful and successful foragers. Weatherhead (1983) has synthesized these two hypotheses and suggests that successful foragers are simultaneously dominant individuals in the roosting aggregation, and as such may secure the most predator proof position within the roost. As of yet, we have not tested any of the above hypotheses.

Lastly, there are a number of important management implications concerning communal roosting in the Pygmy Nuthatch. First, if a large communal roost can be identified, the birds using it may be monitored to assess population density. As the birds utilizing WC50 traveled a minimum of .3 km. to almost 2 km. to reach this snag, a large area may be effectively censused with little expenditure in time or manpower. The distance traveled to WC50 also points out the importance of a single snag to a large population of birds. Identification of these primary roosting cavities may be difficult, thus many snags within a particular area are needed to provide suitable roosts. The exceptional use of one cavity also points out the need for more detailed work on the microhabitats of cavities. Each cavity does not provide the same essential habitat requirements, especially

as these requirements change over time and are different for each species. Finally, one might argue that only one cavity is needed to provide a large number of birds with a suitable roost. However, the system we have studied is highly plastic, with fluctuations in cavity usage between years and within seasons. In previous years, other winter roosting cavities were used with equal frequencies of WC50 this year. The availability of numerous snags with cavities having the proper characteristics is critical to nuthatches and other species that rely on snags for over-wintering habitat.

#### LITERATURE CITED

- Hay, D. 1983. Personal conversation, Department of Biological Sciences, Northern Arizona University, Flagstaff, AZ.
- Knorr, O.A. 1957. Communal roosting of the Pygmy Nuthatch. *Condor*, 59:398-399.
- Lack, D. 1968. Ecological adaptations for breeding in birds. Methuen, London.
- Norris, R.A. 1958. Comparative biosystematics and life history of the nuthatches, *Sitta pygmaea* and *Sitta pusilla*. Univ. of Cal. Publ. in Zool. 56:119-300.
- Ward, P., and A. Zahavi. 1973. The importance of certain assemblages of birds as "information centers" for food finding. *Ibis* 115:517-534.
- Weatherhead, P.J. 1983. Two principal strategies in avian communal roosts. *American Naturalist* 121:237-243.

# Decay Characteristics of Pileated Woodpecker Nest Trees<sup>1</sup>

Roger D. Harris<sup>2</sup>

---

I analyzed decay and mortality characteristics of 42 pileated woodpecker (*Dryocopus pileatus*) nest trees in California. In addition to examining standing trees and wood chips from excavations, eight felled trees were sectioned to determine internal decay characteristics. All cavities in Pinaceae and hardwood trees were associated with decay. Chips excavated by pileated woodpeckers from undecayed softer wood were comparable in hardness to chips from harder wood that had decayed. Pileateds selected a nest cavity site on the basis of the structural quality of the wood and not just the fact that the tree was dead. Management recommendations stress the need for reserving hard snags and allowing for recruitment. Creation of snags by artificial means is not recommended.

---

## INTRODUCTION

To make management decisions consistent with the retention of nesting habitat for pileated woodpeckers (*Dryocopus pileatus*), it is necessary to know their requisites for mortality and decay of nest trees. Conflicting results have been reported over whether pileated woodpeckers require decayed wood in which to excavate nest cavities. Conner et al. (1976) cultured wood samples from six pileated woodpecker nests (five in hardwoods and one in a conifer) and found evidence of decay fungus in each. However, Miller et al. (1979) examined wood chips from nine nests excavated by pileated woodpeckers in Pinaceae trees and found only four with signs of decay. They also sectioned and examined for decay two of the nest snags. Both cavities were excavated in sound wood, although limited areas of sapwood decay were present elsewhere in the trees. McClelland (1977) found chips from 50% of 22 nest excavations by pileated woodpeckers in Pinaceae trees with obvious evidence of heartwood decay.

Furthermore, Conner (1973:36) suggested that pileated woodpeckers apparently lacked the ability to make nest cavities in completely live trees. Yet, Conner et al. (1975) reported that the pileated often excavated through living hardwood cambium to reach a decayed heartwood core. Munro (In Bent 1939:192) observed pileated woodpeckers in British Columbia "cutting" into green cottonwood and popular, presumably *Populus trichocarpus* and *P. tremuloides*. Carriger and Wells (1919) likewise reported "several" pileated woodpecker nests in live aspens in California, where "plenty" of dead

trees were available. Sumner and Dixon (1953) also reported pileated woodpecker nest cavities in live wood in the Sierra Nevada.

This study attempts to resolve some of these conflicting results. Through an analysis of field data on pileated woodpeckers in California, I show that neither mortality nor decay necessarily has to be present as long as the wood is soft enough to be excavated. However, in all but tree species with the softest woods, pileated woodpeckers excavate nest cavities in dead portions that have been softened by decay.

## METHODS

A search for active pileated woodpecker nest sites was made throughout California as part of a larger study on the nesting ecology of the species (Harris 1982). I found eighteen nests in 1979 to 1983. Also, over 350 letters were sent in spring 1980 to birders, land managers, forest owners, and biologists soliciting reports of recent nests. I accepted reports of 24 nest sites in which it was determined that eggs or nestlings had been present; pileated woodpeckers make false starts on nest holes and abandon nest cavities before laying (Bull 1975, McClelland 1977).

I examined all trees for decay characteristics. Hardness of tree was estimated by making a "standardized" thrust of a knife into the tree at breast height and also just below the nest hole, where bark (if present) had been removed, and noting penetration (for a 5-cm blade, very hard = < 1 cm, hard =  $\geq$  1 cm and < 2.5 cm, soft =  $\geq$  2.5 cm and < 5 cm, rotted = 5 cm). The test required equipment readily available in the field, and results were replicable. Top condition, limb condition, and percent of bark were estimated visually.

Causes of tree mortality could not be determined reliably because, for example, fungus may have infected snags after death, masking the

---

<sup>1</sup>Paper presented at the Snag Habitat Management Symposium [Northern Arizona University, Flagstaff, 7-9 June 1980].

<sup>2</sup>Roger D. Harris was a graduate student, Department of Forestry and Resource Management, University of California, Berkeley. Presently he is Director, Flat Rock Brook Center for Environmental Study, Englewood, N.J.



original agent(s) of mortality. In addition, tree mortality is usually a result of a combination of abiotic and biotic stress factors (Bega 1978).

I collected wood chips excavated by woodpeckers from 22 current nest cavities. Experienced wood technologists examined breakage patterns of wood chips to determine soundness. Presence of decay was noted based on fungal remains, rot, and discoloration. If wood chips were judged to be both sound and without macroscopic evidence of decay, they were further examined microscopically for fungal tubes, fungal remains, and rot.

No attempt was made to culture wood chips to identify fungal species. It cannot be reliably determined whether the cultured fungal species was initially present at the time the chips were excavated or had subsequently infected the wood while it was on the ground.

I also examined nest trees for internal decay characteristics and evidence of insect activity. Four nest trees were felled in late August 1980, well after the nestlings had abandoned their nests of the previous spring. Trees were cut horizontally into 2-m sections, nest cavities were sectioned vertically, and horizontal cuts were made immediately above and below the nest cavities. An additional four nest trees fell naturally in winter storms, and were also examined in the same manner as above for internal decay characteristics.

Time since death of Pinaceae nest snags was estimated by the criteria of Cline et al. (1980). Three age classes were delineated: young snags (estimated to be recently killed) had either intact or broken tops, twigs or needles present, >90% bark, and very hard wood; moderate-aged snags (estimated to be 4 to 8 years old) had twigs or branches present, very hard or hard wood, and >50% bark remaining; old snags (estimated to be older than 8 years) had broken tops, no twigs present, very hard or hard wood, and <50% bark remaining.

## RESULTS

Pileated woodpeckers demonstrated plasticity in their choice of nest tree species, representing a range of green wood specific gravities which are indicative of wood hardnesses (Table 1). By the knife test, none of the trees were soft or rotten.

All Pinaceae nest snags had broken tops, except for four white firs with intact tops. (See table 1 for scientific names of trees.) Half of the coast redwoods, neither of the giant sequoias, and 60% of the hardwood nest trees had broken tops.

### Tree Mortality

In seven of the eight live trees, nests were excavated in dead portions of the bole. In the eighth tree, an entirely living coast redwood, the cavity appeared to have been excavated through green cambium into sound heartwood. The nest hole was in an area of clear wood, not the site of a broken limb.

Table 1.--Tree species used for nesting by pileated woodpeckers.

Tree Species <sup>1</sup>	N	sp gr <sup>2</sup>	% Snags	% Broken Tops
CR <sup>3</sup>	2	0.300	50	50
BC <sup>3</sup>	1	0.315	100	100
QA <sup>3</sup>	2	0.344	0	0
GS <sup>4</sup>	2	0.350	0	0
WF	13	0.365	100	69
WA	1	0.368	100	100
PP	9	0.370	100	100
RF	2	0.372	100	100
AE	1	0.421	100	100
D-F	4	0.444	100	100
BLM	1	0.520	0	0
CBO	2	0.529	0	50
MAD	2	0.537	100	100

<sup>1</sup> CR = Coast Redwood (Sequoia sempervirens), BC = Black Cottonwood (Populus trichocarpus), QA = Quaking Aspen (Populus tremuloides), GS = Giant Sequoia (Sequoia giganteum), WF = White Fir (Abies concolor), WA = White Alder (Alnus rhombifolia), PP = Ponderosa Pine (Pinus ponderosa), RF = Red Fir (Abies magnifica), AE = American Elm (Ulmus americana), D-F = Douglas-fir (Pseudotsuga menziessii), BLM = Big Leaf Maple (Acer macrophyllum), CBO = California Black Oak (Quercus kelloggii), MAD = Madrone (Arbutus menziessii).

<sup>2</sup> Hardness of wood is based on specific gravity (sp gr) of green wood (Cockrell et al. 1971, Markwardt and Wilson 1935).

<sup>3</sup> Tree species in which pileated woodpeckers have been known to excavate nest cavities through green cambium.

<sup>4</sup> Tree species in which pileated woodpeckers excavated a nest cavity in undecayed wood.

All pileated woodpecker nest trees in Pinaceae were snags. By snag age class, 32% were young, 46% moderate-aged, and 21% old. Fifty-six percent of the ponderosa pines, but none of the white firs were old.

### Decay Characteristics of Nest Trees

Wood chips collected from current nest excavations in one coast redwood, one California black oak, one madrone, one red fir, seven ponderosa pines, and nine white firs all revealed fungal infection and decay. Excavation chips from a living giant sequoia and the previously described coast redwood showed no evidence of decay or fungal infection under microscopic examination.

Chips excavated by pileated woodpeckers from undecayed softer woods were comparable in hardness to chips from harder woods that had undergone decay (Table 1). Specific gravity of wood chips from dead ponderosa pine and western larch (Larix occidentalis) trees used by pileated woodpeckers for nest cavities was tested by Bull (1975). She calculated a mean specific gravity of 0.34 for dead



and decayed ponderosa pine and western larch, comparable to specific gravities of 0.30, 0.32, and 0.34 for green coast redwood, black cottonwood, and quaking aspen respectively (Markwardt and Wilson 1935).

Decay patterns were patchy on nest trees used by pileated woodpeckers (Fig. 1). Decay characteristics around the nest cavity were not the same as those at breast height, nor was decayed wood distributed in continuous columns for the five white firs and three ponderosa pines examined.

Cavity chambers were excavated through decayed heartwood. Chamber shapes followed the

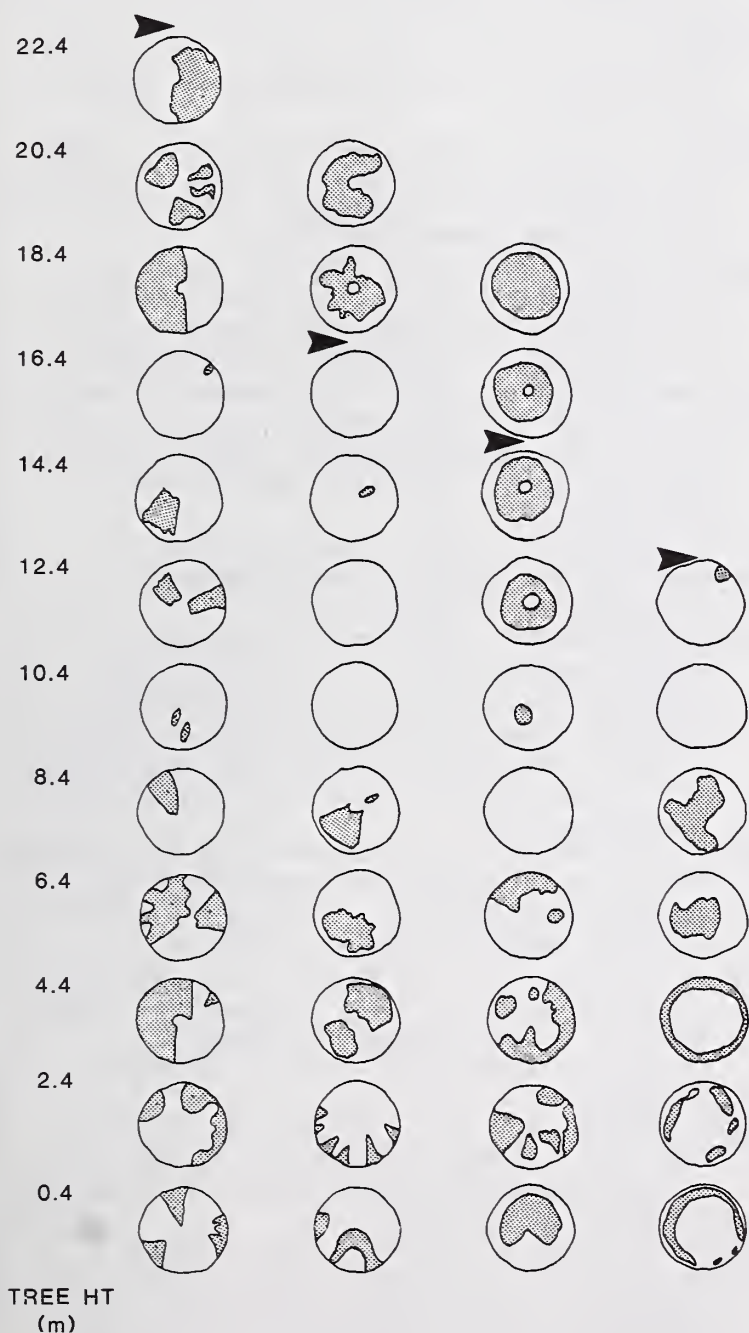

Figure 1.--Illustration of decay patterns (cross hatching) on three horizontally cross-sectioned ponderosa pine snags and a white fir [third from left], Eldorado County, Calif., used by pileated woodpeckers for nesting. Solid black arrows indicate nest hole height. (Diameters are not drawn to scale.)

configuration of decay in the heartwood. Three of the eight cavities showed evidence of insect galleries around entrance holes and corridors. Sapwood surrounding the nest cavities of all eight felled trees was sound by the knife test and visual inspection. Of the nest trees that had fallen by natural causes, none had broken at the level of the nest cavity, attesting to the relative strength of the sapwood surrounding the cavity.

## DISCUSSION

Apparently sound and even green wood of softer tree species was used before decay had set in. In tree species with wood harder than coast redwood, black cottonwood, or quaking aspen, nest cavities were excavated by pileated woodpeckers after the heartwood had been softened by decay.

Broken tops, even on live trees, may serve as entry courts for heart rot fungus (Bega 1978). The high incidence of pileated woodpecker nest trees with broken tops suggests the birds may select for broken topped ones because of their decay characteristics.

Sound sapwood around the cavity chambers provides structural support for the nest and may make it less susceptible to predators (Kilham 1971, Conner 1977). Regardless of tree species, no nest snag was soft or rotten from advanced decay. Such trees apparently cannot support the large nest cavities of pileated woodpeckers. Mean and standard error for 7 nest chambers were  $24.0 \pm 1.1$  cm by  $40.3 \pm 1.9$  cm (Harris 1982). Old white fir snags were not used by pileated woodpeckers, as these less resinous and, therefore, less decay resistant tree species (Cline et al. 1980) either became too soft to be usable or fell down and became unavailable.

Insect galleries around some nest hole entrances and corridors suggest pileated woodpeckers may first use the future nest snag as a foraging site or that insect activity through the otherwise sound sapwood facilitates excavation by the woodpeckers. Neither hypothesis is mutually exclusive.

Areas of fungal decay on nest trees were patchily distributed. Because most Pinaceae snags used by pileated woodpeckers in this study were young or moderate-aged, fungal decay may not have had sufficient time to spread more continuously. In contrast, Conner (1978) in the southeast found decay spread throughout the heartwood in nest snags used by most woodpecker species. Miller et al. (1979) in the northwest reported extensive decay columns in most woodpecker nest trees. In both these studies, trees with extensive decay were used by woodpecker species less well adapted for excavating hard wood than the pileated (Burt 1930).

## Managing for Pileated Woodpeckers

Pileated woodpeckers appear to choose a nest cavity site on the basis of the structural quality of the wood, particularly hardness, and not merely the fact that the tree is dead. Creating snags by topping, girdling, fungal inoculation, or silvicide treatment has been suggested to enhance cavity nesting bird habitat (Bull et al. 1980). I would



not recommend creation of snags by artificial means because the methods may not usually achieve the requisite decay conditions for pileated woodpecker nest trees.

Topping may create entry courts for fungus. Fungal inoculation along with topping may lead to the requisite decay characteristics. Girdling and silvicide treatments might not lead to heart rot (Evans and Conner 1979, Miller and Miller 1980), which typically initiates infection of the tree when alive (Bega 1978). Most importantly, Conner et al. (1981) suggested that trees killed by silvicide fall within 3 to 4 years, resulting in a net loss of snags several years after treatment, compared to an unmanipulated situation.

Forest rotation periods suitable for the maintenance of pileated woodpecker nesting habitat should be calculated on the basis of how long it takes to grow trees with characteristics needed by the species for nesting under local edaphic and climatic conditions. Conner (1978) recommended that stands of largely hardwoods used by pileated woodpeckers should have minimal 150 year rotations to allow time for decay to spread in potential nest trees. In California, however, pileated woodpeckers will use Pinaceae trees less than 75 years old with isolated patches of decay (Harris 1982).

Because pileated woodpeckers do not use soft or rotted snags, it is necessary to reserve sufficient numbers of "hard" snags and to provide for future recruitment of such snags. Most snags fall in winter storms, which vary in strength and frequency. What appears to be a sufficient supply of snags to maintain pileated woodpeckers in a period of "normal" winters may prove insufficient after a particularly severe winter with exceptional wind-fall of snags.

#### ACKNOWLEDGEMENTS

D. Airola and M. G. Raphael were instrumental in all phases of the study. I also thank D. R. McCullough and M. L. Morrison for reviewing the manuscript. M. Sundove was an able field assistant. I am indebted to correspondents from across the state who provided information on nest sites. R. C. Heald and R. H. Barrett provided research facilities and logistical support at the University of California's Blodgett Forest Research Station. I thank F. W. Cobb, R. A. Cockrell, S. Holmen, R. R. Parmeter, and W. W. Wilcox for advice on fungus and analysis of wood chips. Assistance on data analysis and computer operations were generously provided by A. G. Stangenberger, along with M. F. Dedon, D. Pitcher, W. D. Spencer, and W. J. Zielinski. Partial funding was provided by the Wollenberg Foundation, the University Foundation Wildlife Fund, and the Department of Forestry and Resource Management, University of California, Berkeley.

#### LITERATURE CITED

Bega, Robert V. 1978. Diseases of Pacific coast conifers. Agricultural Handbook 521, 206 p. USDA Forest Service, Washington, D. C.

- Bent, Arthur Cleveland. 1939. Life histories of North American woodpeckers. U.S. National Museum Bulletin 174, 334 p. Washington, D.C.
- Bull, Evelyn Louise. 1975. Habitat utilization of the pileated woodpecker, Blue Mountains, Oregon. Masters thesis. 58 p. Oregon State University, Corvallis.
- Bull, Evelyn Louise, A. D. Twombly, and T. M. Quigley. 1980. Perpetuating snags in managed mixed conifer forests of the Blue Mountains, Oregon. p. 325-336. In DeGraaf, R. M. and N. G. Tilghman (editors), Workshop proceed.: management of western forests and grasslands for nongame birds. USDA Forest Service General Technical Report INT-86, 535 p. Intermountain Forest and Range Experiment Station, Ogden, Utah.
- Burt, W. H. 1930. Adaptive modifications in the woodpecker. University of California Publication in Zoology 32:455-524.
- Carriger, H. W. and G. Wells. 1919. Nesting of the northern pileated woodpecker. Condor 21:153-156.
- Cline, S. P., A. B. Berg, and H. M. Wight. 1980. Snag characteristics and dynamics in Douglas-fir forests, western Oregon. Journal of Wildlife Management 44:773-786.
- Cockrell, Robert A., R. M. Knudson, and A. C. Stangenberger. 1971. Mechanical properties of southern Sierra old- and second-growth giant sequoia. Agricultural Experiment Station Bulletin 854, 9 p. Berkeley, Calif.
- Conner, Richard N. 1973. Woodpecker utilization of cut and uncut woodlands. Masters thesis. 82 p. Virginia Polytechnical Institute, Blacksburg.
- Conner, Richard N. 1977. The effect of tree hardness on woodpecker nest entrance orientation. Auk 94:369-370.
- Conner, Richard N. 1978. Snag management for cavity nesting birds. p. 120-128. In DeGraaf, R. M. (editor), Management of southern forests for nongame birds. USDA Forest Service General Technical Report SE-14, 175 p. Southeast Forest Experiment Station, Asheville, N.C.
- Conner, Richard N., J. G. Dickson, and B. A. Locke. 1981. Herbicide-killed trees infected by fungi: potential cavity sites for woodpeckers. Wildlife Society Bulletin 9:308-310.
- Conner, Richard N., R. G. Hooper, H. S. Crawford, and H. S. Mosley. 1975. Woodpeckers nesting habitat in cut and uncut woodlands in Virginia. Journal of Wildlife Management 39:144-150.
- Conner, Richard N., O. K. Miller, Jr., and C. S. Adkisson. 1976. Woodpecker dependence on trees infected by fungal heart rots. Wilson Bulletin 88:575-581.
- Evans, K. E. and R. N. Conner. 1979. Snag management. p. 214-225. In DeGraaf, R. M. and K. E. Evans (editors), Management of northcentral and northeastern forests for nongame birds. Workshop Proceedings, USDA Forest Service General Technical Report NC-51, 268 p. North Central Forest Experimental Station, St. Paul, Minn.
- Harris, Roger D. 1982. Nesting ecology of the pileated woodpecker in California. Masters thesis. 97 p. University of California, Berkeley.

- Kilham, Lawrence 1971. Reproductive behavior of yellow-bellied sapsuckers: I. Preference for nesting in Fomes-infected aspens and nest hole interrelations with flying squirrels, raccoons, and other animals. *Wilson Bulletin* 83:159-171.
- Markwardt, L. J. and T. R. C. Wilson. 1935. Strength and related properties of woods grown in the U.S. U.S. Department of Agriculture Technical Bulletin 479, 99 p. Washington, D.C.
- McClelland, B. Riley. 1977. Relationships between hole-nesting birds, forest snags, and decay in western larch-Douglas-fir forests of the northern Rocky Mountains. Ph.D. dissertation. 495 p. University of Montana, Missoula.
- Miller, E. and D. R. Miller. 1980. Snag use by birds. p. 357-368 In DeGraaf, R. M. and N. G. Tilghman (editors), *Workshop proceedings: management of western forests and grasslands for nongame birds*. USDA Forest Service General Technical Report, 535 p. Intermountain Forest and Range Experiment Station, Ogden, Utah.
- Miller, E., A. T. Partridge, E. L. Bull. 1979. The relationship of primary cavity nesters and decay. *Transactions of the Northeast Section, The Wildlife Society* 36:60-68.
- Sumner, L. and J. S. Dixon. 1953. *Birds and mammals of the Sierra Nevada*. 484 p. University of California Press, Berkeley.



# Snag Use by Selected Raptors<sup>1</sup>

Richard L. Glinski<sup>2</sup>  
Teryl G. Grubb<sup>3</sup>  
Larry A. Forbis<sup>4</sup>

---

Abstract.--As exemplified by the osprey, bald eagle and Mississippi kite, snag use by raptors is variable and includes nesting, resting and hunting. The concept of a snag should be expanded to encompass opportunistic snag use by raptors. Research and management is needed to preserve snags in southwestern riparian deciduous forests.

---

## INTRODUCTION

Few studies have documented the importance of snags to specific raptors. Snag use by birds of prey is diverse and involves perching to rest or hunt, and nesting on exposed limbs or in cavities. The purpose of this paper is to provide insight on raptor use of snags by presenting information on three selected species: the osprey (Pandion haliaetus), bald eagle (Haliaeetus leucocephalus) and Mississippi kite (Ictinia mississippiensis). The data presented does not discuss every population of these species, but it exemplifies the variety of snag structures used by raptors and the management implications of snag use.

Birds of prey are usually opportunistic in their use of available resources, and their use of snags adheres to this tendency. Also, snag use varies among species. Ospreys usually nest in large dead conifers, but under local conditions they will nest on rock pinnacles, large columnar cacti or man-made structures that meet certain criteria. Bald eagles use snags extensively for perching to rest and hunt, and at times for nesting. Mississippi kites commonly forage from snags over areas of favorable prey densities, and often their snag perches consist of minute dead sprigs atop a live tree.

It is incorrect to assume that raptors that nest in snags are more dependent on snag habitat than those that perch or hunt from snags, especially since opportunism will often mask snag use. Nests are constantly used during a breeding season and can be readily discovered, but perches are temporarily used and their importance can be quantified only with more intensive research.

By demonstrating the diversity of snag use by selected raptors, we hope to broaden the concept of a snag. A snag is frequently defined as any dead standing tree (USDA 1978). For cavity nesting species, Evans and Connors (1978) defined a snag as a standing dead or partially dead tree, and Connor (1978) termed a snag as any dead, dying or living tree suitable as a nest site for a cavity nesting bird. Indeed, the process of a live tree dying is often a continuum rather than an abrupt event, with dead sprigs, limbs, and cavities existing in canopies of trees long before they are dead. Many deciduous trees, like cottonwoods (Populus fremontii), provide both dead and live nesting, foraging and resting substrate in a single tree. In addition, during winter deciduous trees assume leafless, snag-like characteristics that can be important for species like wintering bald eagles.

## SNAG USE BY SELECTED RAPTORS

### Snag Use By Ospreys

Throughout their range ospreys prefer nesting in snags (Table 1). Nest snags in California pine forests are generally prominent structures that exist in open tree stands with sparse overstory (Gale and Forbis 1974). Nearly all nests are placed at the top of a snag or snag-like structure rather than on lateral branches. In Florida, Szaro (1972) concluded that nest heights in the intertidal areas are determined by the heights of available dead black mangrove (Azicenna nitida).

---

<sup>1</sup>Paper presented at the Snag Habitat Management Symposium, Flagstaff, AZ, June 7-9, 1983.

<sup>2</sup>Richard L. Glinski is a Regional Wildlife Specialist, Arizona Game and Fish Dept., Mesa, AZ, 85205.

<sup>3</sup>Teryl G. Grubb is a Research Wildlife Biologist, U.S.D.A. Forest Service, Rocky Mnt. Forest and Range Exper. Sta., Tempe, AZ 85287.

<sup>4</sup>Larry A. Forbis is a Forest Wildlife Biologist, Tonto National Forest, Phoenix, AZ 85038.



Table 1.--Habitat characteristics of four nesting osprey populations in the United States.

Locations (number of nests)	Percent of Nests in Snags	Preferred Nest Tree Species (percent preference)	Distance of Nest from Water	References
Oregon (63)	81	Lodgepole Pine ( <u>Pinus contorta</u> ) (67)	<400m (1300 ft) (76% of nests)	Roberts (1970)
Florida (47)	78	Black Mangrove (92)	(intertidal)	Szaro (1972)
Idaho (127)	80 <sup>1</sup>	----	<500m (1640ft) (53% of nests)	Van Deale et al. (1980)
Northern California (61)	93 <sup>2</sup>	Douglas-Fir ( <u>Pseudotsuga menziessi</u> ) (87)	<92m (300ft) (85% of nests)	Gale and Forbis (1974)

<sup>1</sup>Includes power poles and artificial platforms that present a situation similar to a snag.

<sup>2</sup>Includes spike-tops (live trees with dead tops).

Osprey management involves intensive snag management. Gale and Forbis (1974) suggested retaining all snags 38cm (15 inches) in diameter and 12m (40ft) tall in osprey nesting areas, and large live trees every 250m (820ft) as future replacement snags. Van Deale et al. (1980) recommended leaving live trees near snags to prevent wind damage of snags. Roberts (1980) documented the halt of an ongoing snag-clearing program in Oregon because of osprey nesting concerns. His management plan called for a 61m (200ft) "no logging zone" adjacent to water, a 341m (1120ft) "restricted-cutting zone," and retention of all snags and two dominant green trees in the restricted zone. Where necessary, snags can be created by killing live trees (Gale and Forbis 1974, Roberts 1970). Artificial snags for osprey nesting can also be created in selected locations using artificial structures (Van Deale et al. 1980, Gale and Forbis 1974, Roberts 1970, Kahl 1971 and 1972, and Johnson and Melquist 1973).

#### Snag Use By Bald Eagles

Snag use by bald eagles is as opportunistic as the species' foraging and nesting habits. Comparative size, abundance and location of trees are more important for nesting than absolute tree size or tree species. Topography and surrounding habitat vary with the activity, but perching, roosting and nesting usually occur in forested habitat along major lakes, rivers, or marine coastlines. Use-trees must have sturdy branching at sufficient height to support the nest, and good visibility and accessibility as provided by exposed branching, an open crown, crown dominance or tree isolation. Snags are frequently used, especially for perching, whenever they are present within the eagles' nesting or wintering habitat.

Stalmaster and Newman (1979), using a perch-preference index based on the ratio of utilization to availability, found that bald eagles strongly preferred dead trees for daytime perches. Relative height and morphological characteristics of the perch tree, range of vision from the perch, unobstructed flight paths, and proximity to water, feeding sites and open areas were contributing factors. Grubb and Kennedy (1982) also have documented a preference for daytime use of snags in the Southwest. In a continuing study near Stoneman Lake, Arizona, snags comprise less than 10 percent of the standing timber, but of 164 documented perch observations of 5-15 bald eagles, 65 percent were in dead or dead-topped trees. Most perches were in ponderosa pine (Pinus ponderosa) trees on a hillside above the lake and scattered in the pinyon-juniper upland, usually in the vicinity of foraging areas.

Limited winter roost data for the Southwest (Grubb and Kennedy 1982) suggest that some snags are usually present among the high-use trees within small, protected ponderosa pine stringers. Presumably these trees are used for roosting in milder weather, or by subordinates unable to compete for more protective live trees. They may also serve as sentinal perches during evening entry into the roost, when a bird on such a perch indicates the area is undisturbed to approaching eagles (Ingram and Koller 1981).

During the breeding season eagles favor snags for hunting and loafing perches, and for guard perches overlooking the nest site. Snags are particularly important near foraging areas, but are rarely selected as nest trees. In western Washington only 12 (6 percent) of 218 nests surveyed were in snags (Grubb 1976). In addition, the more decadent the tree the more likely a nest was to be inactive. In Arizona between 1977 and 1983, 19 of 71 nesting attempts have been in trees, of which 7 (or 10 percent of total nesting



attempts) were in snags.

One pair of breeding bald eagles in Arizona has consistently selected willow (*Salix* sp.) snags for nesting. These trees become suitable for eagle use only after they are dead and aged so that the restrictive fine branches have fallen away. However, such decadent condition has caused consistent loss of the nests or nest trees, so a permanent artificial "snag" in the form of a tripod was built in 1977 (Grubb 1980). Fortification of dead nest trees is another management alternative to reduce potential loss, as is re-locating nests in live trees nearby. The removal of unsound, dead nest trees or at least the dead nest supporting portions is a legitimate alternative to avoid the risk of losing active snag nests, but such action should be evaluated on a case by case basis.

#### Snag Use By Mississippi Kites

The Mississippi kite locally breeds in the southern United States from Florida through Arizona, nesting in live trees along drainages or in shelterbelts (Parker and Ogden 1979). The principle foraging strategy of this kite has been described generally as soaring and aerial pursuit of insects (Sutton 1939, Skinner 1962, Fitch 1963) Glinski and Ohmart (1983a) found that in Arizona, Mississippi kites captured 41 percent of the nestlings' diet (insects, mainly cicadas) by hawking (locating prey from perches) from snags within 150m (490ft) of the nest. Kites perched 10 to 20m (33-66ft) above the ground on dead branches of cottonwood trees. Kites employed this foraging strategy especially during morning and late afternoon periods when thermals and winds were not available to assist in soaring.

At two nesting sites where foraging behavior was intensively observed the hunting snags were on trees with less than 25 percent canopy die-out (44 percent), trees with 25-50 percent canopy die-out (37 percent), and trees that were half or totally dead (19 percent). Many of the cottonwoods with less than 25 percent canopy die-out appeared to be healthy trees, and some of these trees have sustained 10-20 percent canopy die-out from 1975 through 1983 (Glinski, pers. obs.). The spatial arrangement of cottonwoods around a kite nest is critical to kite reproduction, and the variation of vegetation structure (horizontal and vertical) surrounding nest trees accounted for 71 percent of the variation in nesting success (Glinski and Ohmart 1983a).

The importance of vegetation structure and snag perches to Mississippi kites in other areas of their breeding range is undocumented. These nest site components may be most operative for kites in Arizona since the breezes that may enhance aerial foraging and are typical of kite nesting areas in the Great Plains are usually absent or reduced in central Arizona riparian habitats, particularly at the time when kites are feeding nestlings.

The optimum kite habitat in Arizona is cottonwood-salt cedar (*Tamarix chinensis*) association. Although salt cedar generally will displace cottonwood (Robinson 1965), the vegetation associated with kite nesting areas in Arizona appears to be in the transition period when salt cedars are attaining heights of 3-8m (10-26ft) and when cottonwood trees 10-20m (33-66ft) are dying and providing snag perches. Salt cedar provides excellent habitat for the cicadas on which kites prey (Glinski and Ohmart 1983b), and the presence of cottonwoods with numerous snag forage perches protruding above the salt cedar presently combines to make certain riparian habitats in the Southwest excellent habitat for the Mississippi kite. Levy (1971) first documented the Mississippi kite in Arizona in 1970, and records for New Mexico began in 1950 (Parker and Ogden 1979). The recent occurrence of this kite in the Southwest may well coincide with the invasion of salt cedar and the initial stages of cottonwood degeneration, and thus with the development of favorable prey and foraging habitat.

#### CONCLUSIONS AND RECOMMENDATIONS

Snag use by raptors involves nesting, foraging and resting activities which, for most species, have not been sufficiently quantified to prescribe snag management guidelines. The definition of a snag needs to be expanded to encompass opportunistic snag use by raptors.

Ospreys commonly nest in prominent snags in open tree stands, and on artificial snags that retain similar features. Snag management for ospreys involves preserving snags, creating snags by killing live trees, and reserving living trees for future creation of snags. These management techniques are particularly applicable in pine habitats where large trees are common.

Bald eagles commonly perch and occasionally nest in snags. Throughout their breeding and wintering habitat, maintenance of existing snags and long-term provision for continued snag availability is an important management objective for bald eagles, particularly in foraging and loafing areas. Creation of snags or the construction of artificial snags also offers management potential for supplementing marginal habitat or redirecting eagle use away from disturbed areas.

The Mississippi kite in Arizona forages from snag perches. Its dependence on snags is not obvious since kite snag perches are often a dead sprig or limb in the canopy of a living tree. In the Southwest, many riparian deciduous trees provide snag habitat (dead limbs and cavities) throughout much of their lives, and thus to manage for broadleaf riparian snags generally is to manage for regeneration and maintenance of riparian trees. This effort will likely require a greater commitment than the maintenance of pine snags since more ecological factors are involved with riparian plant succession (Johnson et al. 1977). As the salt cedar-cottonwood association degrades to a salt cedar monoculture and cottonwood nest trees and snag perches are eliminated,



the kite population in the Southwest will likely decline. The potential for riparian deciduous trees in the Southwest to afford snag habitat for raptors will likely diminish as plant succession occurs in degraded river bottoms. Intensive research and management techniques are needed to preserve riparian deciduous snags.

#### Acknowledgements

We express our gratitude to Laura Jean Gable for typing the manuscript, and to Jerry A. Davis, Gregory A. Goodwin, Gary C. Bateman, Richard A. Ockenfels and Glen C. Dickens for providing a format to convey the importance of snags.

#### Literature Cited

- Connor, R.M. 1978. Snag management for cavity nesting birds, p. 120-128. *In Proc. of the Workshop Management on Southern Forests for Nongame Birds*. USDA For. Serv. Gen. Tech. Rept. SE-14.
- Evans, K.E., and R.N. Connor. 1978. Snag Management, p. 214-225. *In Proc. of the Workshop Management on Southern Forests for Nongame Birds*. USDA For. Serv. Gen. Tech. Rept. SE-14.
- Fitch, H.S. 1963. Observations on the Mississippi Kite in Southwestern Kansas. *Univ. KS Mus. Nat. Hist. Publ.* 12:503-519.
- Gale, M., and L. A. Forbis. 1974. A Habitat Management Plan for Osprey on the Klamath National Forest. USDA Forest Service, California Region. 46 pp.
- Glinski, R.L. and R.D. Ohmart. 1983a. Breeding ecology of the Mississippi Kite (Ictinia mississippiensis) in Arizona. *Condor* (in press).
- Glinski, R.L., and R.D. Ohmart. 1983b. Factors of reproduction and population densities in the Apache cicada (Diceroprocta apache). *Southwestern Nat.* (in press).
- Grubb, T.G. 1980. An artificial bald eagle nest structure. USDA Forest Service Research Note RM-383. Rocky Mountain Forest & Range Experiment Station, Ft. Collins, Colorado. 4p.
- Grubb, T.G. 1976. A survey and analysis of bald eagle nesting in western Washington. MS thesis. University of Washington, Seattle. 87p.
- Grubb, T.G., and C.E. Kennedy. 1982. Bald eagle winter habitat on southwestern National Forests. USDA Forest Service Research Paper RM-237. Rocky Mountain Forest & Range Experiment Station, Ft. Collins, Colorado. 13p.
- Ingram, T.E., and H. Koller. 1981. Wintering bald eagle terminology, p. 245-248. *In Proc. of 1981 Bald Eagle Days*. Eagle Valley Environmentalists, Inc. Apple River, Illinois.
- Johnson, D.R., and W.E. Melquist. 1973. Unique, Rare and Endangered Raptorial Birds of Northern Idaho: Nesting Success and Management Recommendations. University of Idaho and USDA Forest Service. Pub. R1-73-021. 42p.
- Johnson, R.R., L. Haight, and J.M. Simpson. 1977. Endangered species vs endangered habitats: a concept, p. 68-79. *In Importance, Preservation and Management of Riparian Habitat: A Symposium*. USDA For. Serv. Gen. Tech. Rept.
- Kahl, J.R. 1971. Osprey Habitat Management Plan. USDA Forest Service, Susanville, California. 38p.
- Kahl, J.R. 1972. Osprey Management on the Lassen National Forest. California-Nevada Section. The Wildlife Society. 1972 Trans. p. 7-13.
- Levy, S.H. 1971. The Mississippi kite in Arizona. *Condor* 73:476.
- Parker, J.W., and J.C. Ogden. 1979. The recent history and status of the Mississippi Kite. *Am. Birds* 33:119-129.
- Roberts, H.B. 1970. Management of the American Osprey on the Deschutes National Forest, Oregon. *Raptor Research News* 4(6) 168-177.
- Robinson, T.W. 1965. Introduction, spread and aerial extent of salt cedar (Tamarix) in the western states. U.S. Geol. Surv. Prof. Pap. 491-A. Gov. Printing Office, Washington, DC.
- Skinner, R.W. 1962. Feeding habits of the Mississippi Kite. *Auk* 79:273-274.
- Stalmaster, M.V., and J.R. Newman. 1979. Perch site preference of wintering bald eagles in northwest Washington. *J. of Wildlife Management* 43(1):221-224.
- Sutton, G.M. 1939. The Mississippi Kite in Spring. *Condor* 41:41-53.
- Szaro, R.C. 1972. The Breeding Biology of the Osprey (Pandion haliaetus) at Seahorse Key, Florida. MS Thesis, University of Florida. 47p.
- USDA. 1978. Definition of a snag. For. Serv. Man. 5151.13C-1. Region III Supplement No. 119.
- Van Deale, L.J., H.A. Van Deale, and D.R. Johnson. 1980. The Status and Management of Osprey Nesting in Long Valley, Idaho. USDI, WPRS; Central Snake Project Office Report; Boise, Idaho. 49p.



# Snag Use by Birds in Douglas-fir Clearcuts<sup>1</sup>

Bruce G. Marcot<sup>2</sup>

---

Abstract.--In Douglas-fir (Pseudotsuga menzeisii) clear-cuts in northwestern California, bird species richness (mean number of species) and detection rates (mean number of birds of all species recorded per 10-minute count) were significantly greater in grass/forb and early brush/sapling stages where snags were present compared to where snags were absent. Mean detection rates and percent occurrence at count points of five primary and four secondary cavity nesters were significantly greater in clear-cuts with snags compared with clear-cuts without snags during breeding and post-breeding seasons. An exception was chestnut-backed chickadee (Parus rufescens). Most cavity-nesting species probably nested in adjacent, forested stands and used the clear-cuts for foraging.

---

## INTRODUCTION

Forest management practices associated with harvesting timber, such as cutting, hazard reduction, and such site preparation methods as burning and mechanical disturbance cause the loss of snags. Over a rotation cycle, numbers of snags, especially large snags, will decline from these practices operating in concert over a large forest area undergoing intensive silvicultural treatment.

One effect of long-term declines in snag densities has been documented as declines in populations of hole-nesting birds (Haapanen 1965, Conner et al. 1975, McClelland and Frissell 1975, Bull and Meslow 1977, Scott 1979). For example, in Finland, Haapanen (1965) found that the density of hole-nesting birds decreased by 44 percent when large snags were eliminated from managed forests. Similarly, in Arizona, Scott (1979) reported that in ponderosa pine (Pinus ponderosa) habitat where conifer snags were removed during a timber harvest, bird population densities decreased 27 percent and hole-nesting bird densities decreased 51 percent, while population densities increased in unharvested, adjacent control plots and harvested plots where snags were retained.

To provide a basis for managing snags during timber harvest, relationships of snag distribution and density to faunal distribution and abundance in early successional stages should be documented. The objective of this paper is to compare count frequency and occurrence of bird species in Douglas-fir (Pseudotsuga menzeisii) clear-cuts where snags had been retained and where snags had been removed during timber harvest.

## STUDY AREA AND METHODS

Thirty-seven Douglas-fir clear-cuts, representing recent forest management practices, were selected in the Six Rivers and Shasta-Trinity National Forests in northwestern California. Three growth classes were represented (Table 1): 1) grass/forb (less than 20 percent woody vegetation cover, brush generally under 1 m in height), 2) early brush/sapling (over 20 percent woody cover, brush generally under 3 m in height), and 3) late brush/sapling (dense woody cover, brush generally over 3 m in height). The clear-cuts had been burned, planted with seedling Douglas-fir, and, except for the grass/forb stage, sprayed with herbicides (2,4-D or 2,4,5-T). The predominant cover on most of the clear-cuts was species of brush and broad-leaf hardwoods, including bull thistle (Cirsium vulgare) and berries (Rubus spp.) in the grass/forb stage, and mountain whitethorn (Ceanothus cordulatus), deerbrush (C. integerrimus), tobacco brush (C. velutinus), canyon live oak (Quercus chrysolepus), tanoak (Lithocarpus densiflora), blue elderberry (Sambucus caerulea), Pacific madrone (Arbutus menziesii), and gooseberry (Ribes spp.) in the

---

<sup>1</sup> Paper presented at the Snag Habitat Management Symposium, Flagstaff, Arizona, 7-9 June 1983.

<sup>2</sup> Bruce G. Marcot is a Research Assistant with Oregon Cooperative Wildlife Research Unit, Department of Fisheries and Wildlife, Oregon State University, Corvallis, Ore.



Table 1.--Characteristics of the Douglas-fir (*Pseudotsuga menzeisii*) clear-cut study plots, northwestern California. Data are means with ranges in parentheses.

Growth stage	Stand size (ha)	No. bird count points	No. years since activity (as of summer 1981)			
			Cutting	Burning	Planting	Spraying <sup>1</sup>
Grass/forb (13 plots)	9.3 (5-17)	14	5 (13 plots) (3-9)	3 (11 plots) (1-5)	2 (13 plots) (0-3)	(0 plots)
Early brush/sapling (10 plots)	17.8 (11-25)	15	13 (10 plots) (6-21)	9 (8 plots) (2-14)	9 (10 plots) (4-19)	5 (5 plots) (1-7)
Late brush/sapling (14 plots)	17.5 (9-25)	23	15 (14 plots) (5-19)	14 (5 plots) (5-18)	14 (14 plots) (3-18)	7 (11 plots) (5-10)

<sup>1</sup>Aerially-applied herbicides (2,4-D or 2,4,5-T) for brush control.

brush/sapling stages. Some of the late brush/sapling stage clear-cuts contained planted ponderosa pine or naturally seeded white fir (*Abies concolor*).

Topographic characteristics of the clear-cuts were taken from orthographic-photo maps (scales 1:12,000 or 1:24,000) or from on-site measurements (percent slope).

Vegetation was measured around each count point by placing each of three 2 x 30 m belt transects at random distances between 18 and 90 m from the count point. Compass direction from the count point to the first belt was chosen randomly, and the other two belts were then located at increments of 120°. Within each belt, plant height and foliage volume were measured using the HTVOL procedure of Mawson et al. (1976), which entails visually estimating plan and profile shapes of each plant's foliage *en masse*, measuring foliage depth and breadth, and computing overall volumes.

Along one edge of each 30 m belt, down wood was measured and weights of woody debris of all sizes were estimated using the procedure of Brown (1974).

Fifty-two bird count points were positioned centrally in the clear-cuts, 13 in clear-cuts where snags were absent and 39 in clear-cuts where snags were left during harvest. A snag was defined as any standing dead tree at least 10 cm in diameter at breast height and at least 1.8 m tall (Thomas et al. 1979). Two count points were used in some of the larger clear-cuts, but the points were positioned at least 360 m apart or were separated by a ridge. A total of 2580 ten-minute bird counts were conducted: 468 at points where snags were present and 132 at points where snags were absent, during spring and breeding seasons (12 March to 16 June 1982); and 1500 at points where snags were present and 480 at points where snags were absent, during summer and fall seasons (6 August to 18 November 1981 and 17 June to 3 November 1982).

Where present, snag densities ranged from about 2 to 10 per ha within 200 m of the count point. Snags were mostly Douglas-fir, Pacific madrone, or tanoak. All snags were generally in early stages of decomposition, i.e. characterized by relatively sound wood with at least some of the bark intact (Thomas et al. 1979) and ranged in height from 1.8 to 60 m. Snags were located in the center portions of the clear-cuts either as scattered individuals or, less often, in groups of ten to fifty.

## RESULTS

Topographic and vegetation characteristics at bird count points where snags were left did not differ significantly from characteristics at points where snags were absent (unpaired t-tests, all  $P > 0.05$ ), except for percent occurrence of live residual trees (Table 2). Generally, when snags were left during timber harvest, so were scattered live residual trees in densities roughly equal to those of snags.

The average number of all bird species observed at count points in clear-cuts with snags did not differ significantly from the number observed in clear-cuts without snags, when growth stages and seasons were combined (Table 3). However, average detection rates of all bird species combined were significantly higher in clear-cuts with snags compared with clear-cuts without snags. Differences in average number of bird species and detection rates in clear-cuts with snags compared with clear-cuts without snags were significant in grass/forb and early brush/sapling stages and were insignificant in the late brush/sapling stage.

Mean detection rates of the six primary and four secondary cavity-nesting species observed during counts were consistently greater in clear-cuts with snags compared with clear-cuts without snags (Table 4). This was true in both seasons tested (Wilcoxon's signed-ranks test,  $P = 0.05$ ), with two exceptions: pileated woodpecker (scientific names in Table 4), which was not observed during spring and breeding seasons, and chestnut-backed chickadee.



Table 2.--Topographic and vegetation characteristics at bird count points in Douglas-fir clear-cuts with and without snags.

Characteristic	Clear-cuts with snags		Clear-cuts without snags	
	Mean	S.D.	Mean	S.D.
Elevation (m)	1060	142	1045	147
Size (ha)	15.2	5.5	15.1	6.4
Slope (%)	46	19	50	21
Aspect (% of total)				
N (315-45°)	54		52	
E (46-135°)	16		19	
S (136-225°)	6		7	
W (226-315°)	25		21	
No. plant species over 10 cm tall	18	6.5	25	11.2
Percent count points with live residual trees	95		23**	
Total foliage volume (m <sup>3</sup> /ha)	8407	9378	6474	6141
Brush height (m)	4.4	2.9	3.8	2.6
Down wood (metric tons/ha)	94.7	57.8	62.6	41.0

\*\* Significantly different ( $P < 0.001$ , Chi-square test).

Percent occurrences at count points of these same 10 species were the same or greater in clear-cuts with snags compared with clear-cuts without snags in at least one of the two seasons tested (Table 4). In particular, percent occurrence of red-breasted sapsucker, hairy woodpecker, house wren, Bewick's wren, and western bluebird were significantly greater in clear-cuts with snags compared with clear-cuts without snags during spring and breeding seasons. Other species showed the same trend during summer and fall seasons. Again, the exception was chestnut-backed chickadee, which showed a marginally, significantly greater percent occurrence in clear-cuts without snags during spring and breeding seasons and no difference during summer and fall seasons.

#### DISCUSSION AND MANAGEMENT IMPLICATIONS

The use of comparative, observation data to infer a causal link between snag presence in clear-cuts and distribution and abundance of birds raises several important considerations.

First, the presence of snags did not seem to bias the bird counts by increasing the likelihood of birds being seen. Twenty-two percent of a subsample of 19,282 observations of all bird species in all seasons from count points where snags were left, and 26 percent of a subsample of 4,940 observations from points where snags were removed, were recorded as "seen" rather than "heard only". The percent "seen" was also not significantly different (chi-square tests,  $P > 0.05$ ) between count points where snags were left and where snags were removed when observation subsamples were stratified by season or by any of the species presented in Table 4.

Second, the presence of factors other than snags at count points may have influenced distri-

bution and abundance of bird species. Yet, aside for snag presence, Table 2 suggests no factor to serve at least as a working hypothesis to account for differences in detection rates and percent occurrence of cavity-nesting bird species, except for presence of live residual trees. Indeed, a number of the cavity-nesting species were observed using live trees for perches. Average detection rates of the cavity-nesting species in clear-cuts where live residual trees were present showed similar patterns as with snags present and absent. However, percent occurrence of some bird species at count points with and without live residual trees showed different patterns than percent occurrence of bird species at count points with and without snags (Table 4). That is, snags and live trees may relate differently to the distribution of some bird species in clear-cuts. In both seasons surveyed, detection rates (Wilcoxon's signed-ranks tests,  $P < 0.05$ ) of all cavity-nesting species were significantly less at count points where live residual trees were retained and snags were removed than at count points where both live residual trees and snags were retained. This, again, suggests a relation between snag presence and distribution and abundance of cavity-nesting species.

All the cavity-nesting species were observed to use snags in clearcuts for perching, and many were observed using snags for foraging. Observations of nests were incidental. Most of the cavity-nesting species probably nested in nearby uncut stands and used clear-cuts as foraging habitat, such as reported by Morrison and Meslow (1983) in Coast Range clear-cuts of Oregon.

All the primary and secondary cavity nesting species observed in this study, except pileated and acorn woodpeckers, are known to nest in Douglas-fir cut-over areas (Hager 1960, Mannan et al. 1980, Morrison and Meslow 1983), although

Table 3.--Number of bird species detected at count points and detection rates (number of birds of all species recorded per 10-minute count) in Douglas-fir clear-cuts, 6 Aug 1981 to 3 Nov 1982, excluding the winter period 19 Nov 1981 to 11 Mar 1982.

Growth stage	Clear-cuts with snags			Clear-cuts without snags			Significance level <sup>1</sup>
	Mean	S.D.	N	Mean	S.D.	N	
NUMBER OF BIRD SPECIES <sup>2</sup>							
Grass/forb	13.7	4.3	29	10.8	3.2	9	0.07
Early brush/sapling	21.7	5.4	49	19.3	4.9	25	0.07
Late brush/sapling	20.5	5.9	73	20.2	5.7	17	0.49
All	19.6	6.2	151	18.1	5.9	51	0.14
DETECTION RATES <sup>3</sup>							
Grass/forb	12.26	7.31	372	8.20	7.66	108	<0.001
Early brush/sapling	16.33	6.35	564	11.84	3.96	300	<0.001
Late brush/sapling	13.53	6.07	876	13.49	5.30	204	0.18
All	14.14	6.57	1812	11.75	5.40	612	<0.001

<sup>1</sup>Unpaired t-test.

<sup>2</sup>N = no. of plot-censuses. A plot-census consisted of 12 ten-minute counts at each point.

<sup>3</sup>N = no. of 10-minute counts.

Morrison and Meslow (1983) reported very low breeding densities of cavity nesters in their clear-cut study plots. Species-specific studies of bird foraging, nesting, and roosting may reveal more direct relationships between bird populations and snags in clear-cuts. For example, Brawn et al. (1982) reported that snags were important winter foraging substrates for cavity nesters in oak-hickory forest.

Snag blowdown occurred during winter in some upper-slope and ridgetop clear-cuts in this study. On one clear-cut, all (several dozen) snags in one centrally located patch were reduced two-thirds in height from blowdown. Scott (1978) noted that about 30 percent of ponderosa pine snags were lost during timber harvest and 34 percent after harvest to subsequent logging, blowdown, or fuel wood cutting. When clear-cutting, additional snags and defective trees may be retained to offset such losses.

Care should be taken during site-preparation following clear-cutting not to disturb residual

trees and snags. When burning, woody debris may first be cleared away at least 6 m from the base of snags or trees, as charring greatly reduces the quality of wood for nest excavation and foraging use by birds (e.g., Maser et al. 1979).

#### ACKNOWLEDGEMENTS

I thank Michael Morrison, Martin Raphael, and E. Charles Meslow for their helpful reviews and frank comments on early drafts. I am grateful to Charlotte Vickers for typing the manuscript and suffering through all the revisions with such good cheer. This study was conducted under the auspices of the Oregon Cooperative Wildlife Research Unit: Oregon State University, Oregon Department of Fish and Wildlife, U.S. Fish and Wildlife Service, and the Wildlife Management Institute cooperating. The USDA Forest Service, Pacific Southwest Region, funded the study. Oregon State University Agricultural Experiment Station Technical Paper 6842.



Table 4. Abundance and distribution of cavity-nesting bird species in Douglas-fir clear-cuts in northwestern California during spring and breeding (Sp + B) and summer and fall (Su + F) seasons.

Species	Season	Detection rate (mean no. observed per count)		Percent occurrence (at count points)			
		with snags	without snags	with snags	without snags	with trees	without trees
Primary Cavity Nesters							
Northern flicker ( <i>Colaptes auratus</i> )	Sp + B	0.13	0.11	44	45	44	45
	Su + F	0.16	0.09	64	50*	62	55
Pileated woodpecker ( <i>Dryocopus pileatus</i> )	Sp + B	0.00	0.00	0	0	0	0
	Su + F	0.007	0.004	6	3+	6	3+
Acorn woodpecker ( <i>Melanerpes formicivorus</i> )	Sp + B	0.04	0.02	13	18	10	27**
	Su + F	0.18	0.02	28	18*	26	23
Red-breasted sapsucker ( <i>Sphyrapicus ruber</i> )	Sp + B	0.08	0.01	26	9**	23	18
	Su + F	0.02	0.01	9	5+	9	5+
Hairy woodpecker ( <i>Picoides villosus</i> )	Sp + B	0.02	0.01	15	9*	15	9*
	Su + F	0.03	0.01	17	5**	17	5**
Chestnut-backed chickadee ( <i>Parus rufescens</i> )	Sp + B	0.08	0.11	33	45+	33	36
	Su + F	0.22	0.28	55	60	56	58
All primary cavity nesters							
Total	Sp + B	0.35	0.26				
	Su + F	0.62	0.41				
Average	Sp + B	0.06	0.04				
	Su + F	0.10	0.07				
All woodpeckers							
Total	Sp + B	0.27	0.15				
	Su + F	0.40	0.13				
Average	Sp + B	0.05	0.03				
	Su + F	0.08	0.03				
Secondary Cavity Nesters							
Violet-green swallow ( <i>Tachycineta thalassina</i> )	Sp + B	0.002	0.00	3	0+	3	0**
	Su + F	0.29	0.10	14	8*	12	13
House wren ( <i>Troglodytes aedon</i> )	Sp + B	0.82	0.55	64	36**	64	36**
	Su + F	0.20	0.12	40	30+	38	38
Bewick's wren ( <i>Thryomanes bewickii</i> )	Sp + B	0.11	0.03	36	18**	33	27
	Su + F	0.08	0.03	28	18*	26	23
Western bluebird ( <i>Sialia mexicana</i> )	Sp + B	0.18	0.05	38	9**	36	18**
	Su + F	0.16	0.11	30	20*	26	33
All secondary cavity nesters							
Total	Sp + B	1.11	0.63				
	Su + F	0.73	0.36				
Average	Sp + B	0.28	0.16				
	Su + F	0.18	0.09				

<sup>1</sup>Chi-square test of difference of percent occurrence.  
+ 0.05 < P < 0.10  
\* 0.01 < P < 0.05  
\*\* P < 0.01

LITERATURE CITED

- Brawn, J.D., W.H. Elder, and K.E. Evans. 1982. Winter foraging by cavity nesting birds in an oak-hickory forest. *Wildl. Soc. Bull.* 10:271-275.
- Brown, J.K. 1974. Handbook for inventorying downed woody material. USDA Forest Service Gen. Tech. Rept. INT-16.
- Bull, E.L. and E.C. Meslow. 1977. Habitat requirements of the pileated woodpecker in northeastern Oregon. *J. For.* 75:335-337.
- Conner, R.N., R.G. Hooper, H.S. Crawford, and H.S. Mosby. 1975. Woodpecker nesting habitat in cut and uncut woodlands in Virginia. *J. Wildl. Manage.* 39:144-150.
- Haapanen, A. 1965. Bird fauna of the Finnish forests in relation to forest succession. I. *Ann. Zool. Fenn.* 2:153-196.
- Hager, D.C. 1960. The interrelationships of logging, birds, and timber regeneration in the Douglas-fir region of northwestern California. *Ecology* 41:116-125.
- Mannan, R.W., E.C. Meslow, and H.M. Wight. 1980. Use of snags by birds in Douglas-fir forests, western Oregon. *J. Wildl. Manage.* 44:787-797.
- Maser, C., R.G. Anderson, K. Cromack, Jr., J.T. Williams, and R.E. Martin. 1979. Dead and down woody material. Pp. 79-95 in J.W. Thomas (ed.). *Wildlife habitats in managed forests the Blue Mountains of Oregon and Washington.* USDA Forest Service Agric. Handbk. No. 553. 512 pp.
- Mawson, J.C., J.W. Thomas, and R.M. DeGraaf. 1976. Program HTVOL the determination of tree crown volume by layers. USDA Forest Service Res. Paper NE-354.
- McClelland, B.R. and S.S. Frissell. 1975. Identifying forest snags useful for hole-nesting birds. *J. For.* 73:414-417.
- Morrison, M.L., and E.C. Meslow. 1983. Avifauna associated with early growth clearcuts in the Oregon Coast Range. USDA Forest Service PNW (in press).
- Scott, V.E. 1978. Characteristics of ponderosa pine snags used by cavity-nesting birds in Arizona. *J. For.* 76:26-28.
- Scott, V.E. 1979. Bird response to snag removal in ponderosa pine. *J. For.* 77:26-28.
- Thomas, J.W., R.G. Anderson, C. Maser, and E.L. Bull. 1979. Snags. Pp. 60-77 in J.W. Thomas (ed.). *Wildlife habitats in managed forests the Blue Mountains of Oregon and Washington.* USDA Forest Service Agric. Hndbk. No. 553.



# Snags as Indicators of Habitat Suitability for Open Nesting Birds<sup>1</sup>

John M. Marzluff<sup>2</sup> and L. Jack Lyon<sup>3</sup>

---

Abstract.--The habitat requirements of open nesting birds were examined in 19, five hectare, plots arranged along an altitudinal gradient in western Montana. Seven, mature forest birds were examined in detail. Percent shrub and low canopy cover (0.5-1.5m), mid-canopy cover (8-25m), and the number of large diameter stems (25-50 cm dbh) were of major importance to this avian community. Increased avian diversity was associated with increased structural complexity of plots. Precise habitat recommendations for each species are proposed and related to more easily quantified snag variables. Management of western Montana forests to sustain production of 80 snags per hectare, preferably in a clumped distribution, will provide suitable habitat not only for cavity nesters, but also for sensitive open nesting species.

---

## INTRODUCTION

That avian community structure and density of individual species respond to vegetative characteristics is well known (For example, Balda 1975, Anderson 1979, James and Wamer 1982). This response is commonly quantified by observing changes in the avian community following concomitant changes in vegetation through successional stages (Anderson 1979, Smith and MacMahon 1981), or in response to timber harvesting (Hagar 1960, Kilgore 1971, Webb et al. 1977). Such studies have shown that although avian biomass may remain constant following habitat alteration, species composition changes drastically. In addition, structural, not taxonomic characteristics of the vegetation are the primary determinants of avian communities and populations (MacArthur and MacArthur 1961, James 1971, Roth 1976). Yearly abiotic fluctuations, however, may reduce the direct response of the avian community to the plant community (Stamp 1978).

Use of multivariate statistical techniques to examine numerous habitat measurements simultaneously has greatly added to our knowledge of bird species habitat requirements. In general, these studies also support the importance of habitat structure. Specifically, combinations of variables such as percent canopy cover, canopy height, number of tree species, and number of stems in smaller dbh categories (< 9 cm) have been found to influence avian communities (James 1971, Anderson and Shugart 1974, Whitmore 1975, Johnston 1979).

In comparison to other regions, relatively few studies have been conducted in the Rocky Mountains of Montana to determine habitat requirements of non-game birds (Manuwal 1968, McClelland and Frissell 1975, McClelland et al. 1978, Harvey and Weaver 1979, McClelland 1979, Ramsden et al. 1979). This information is crucial to the forest manager who, with it, will be able to weigh the effects of alternative management strategies on specific groups of birds. Our main objective is to precisely quantify the habitat requirements of seven open nesting birds. The species selected are primarily dependent upon mature old growth or riparian forests and hence are most susceptible to structural changes induced by timber management. In addition, we propose that snag counts and measures of snag basal area can be used as indicators of habitat suitability for these species. This technique, although indirect, is useful to managers since the measurement of appropriate percent cover and stem variables is tedious, imprecise, and costly.

---

<sup>1</sup>Paper presented at the Snag Habitat Management Symposium, Flagstaff, Arizona, June 7-9, 1983.

<sup>2</sup>Current address: Department of Biological Sciences, Northern Arizona University, Flagstaff, Arizona, 86001.

<sup>3</sup>Wildlife Research Biologist, USDA Forest Service, Forestry Sciences Lab, Missoula, Montana, 59806.

## METHODS

### Study Areas

Nineteen study plots were located in Lolo Creek drainage from Lolo, Montana to Lolo Pass along U.S. Highway 12. These sites included habitats varying from ponderosa pine (*Pinus ponderosa*) types at 1052m to Engelmann spruce (*Picea engelmannii*)-subalpine fir (*Abies lasiocarpa*) types at 1628m. Representative forest communities ranging from clear-cuts to old growth were selected on varying aspects. Three paired sets of riparian and upland sites were situated along the altitudinal gradient.

### Field Methods

Birds were censused along line transects (Emlen 1971) laid out by compass in a rectangular pattern on each study plot. Each transect consisted of 20 segments, 25m in length, for a total transect length of 500m.

Birds were censused between a half-hour before sunrise and noon on days with reasonably clement weather during the interval June 15 to September 15, 1979. The observer walked slowly along the transect route recording all birds heard or seen within a belt approximately 50m on either side of the transect line. This provided for a total census area of 5 ha per study plot. A three minute pause every 25m allowed the observer to carefully scan the area thus increasing the probability that all birds would be detected. Each transect was censused five times through the course of the study. Bird species, distance from the transect line, height above the ground (if seen), and observation type (sight/sound) were recorded.

Vegetation data were taken on circular plots, 5.64m in radius (100m<sup>2</sup>), every 25m along the transect. This provided 20 samples per transect. Twenty habitat variables were measured in each plot (Table 1). Percent cover at each of the levels measured was assigned to one of the following cover classes: 0 = no cover, 1 = less than 5% cover, 2 = 5-25% cover, 3 = 25-50% cover, 4 = 50-75% cover, and 5 = 75+% cover. Absolute counts of live and dead tree stems and pieces of downed woody material and stumps in each of the plots were also recorded. The most abundant tree, shrub, and forb species were identified and noted. A 5 BAF prism was used to measure tree and snag basal area. The average value for each vegetation measurement per plot was used in subsequent analyses. In addition to these site data, average elevation and aspect for each 100m segment was recorded.

### Statistical Procedures

Pearson correlation coefficients were computed for all first order combinations of variables. Multiple regression equations were generated by REX (Grosenbaugh 1967), a multivariate combinational screening program in





Table 1.--Habitat variables measured in each 100 m<sup>2</sup> plot.

1. Percent cover 0 to .5 meters
2. Percent cover .5 to 1.5 meters
3. Percent cover 1.5 to 2.5 meters
4. Percent cover 2.5 to 8 meters
5. Percent cover 8 to 25 meters
6. Percent cover 25+ meters
7. Number of live and dead stems less than 2 cm dbh
8. Number of live and dead stems 2 to 5 cm dbh
9. Number of live and dead stems 5 to 10 cm dbh
10. Number of live and dead stems 10 to 25 cm dbh
11. Number of live and dead stems 25 to 50 cm dbh
12. Number of live and dead stems 50+ cm dbh
13. Square meters of downed logs and stumps
14. Prominent tree species
15. Prominent shrub species
16. Prominent grass and forb species
17. Tree basal area
18. Snag basal area
19. Elevation
20. Aspect

which all possible linear combinations of 18 independent variables taken three at a time were screened for the best-fitting regression. All computer runs were performed on a Perkin-Elmer 3220 computer located at the Northern Forest Fire Lab, Missoula.

## RESULTS

During the course of this 12 week study 6,000 birds of 73 species were recorded. Bird species diversity (MacArthur and MacArthur 1961) and the absolute number of bird species both increased in study plots of increasing structural complexity (Fig. 1). Mature riparian forests had twice the number of species and more than four times the avian diversity than did the structurally uniform plantation plot.

HABITAT	MATURE RIPARIAN FOREST	SELECTIVELY LOGGED PLOT	CLEARCUT PLOT	PLANTATION PLOT
				
H'	11.00	7.34	6.29	2.67
NUMBER OF SPECIES	14	12	11	7

$$H' = 1 / \sum p_i^2$$

Figure 1.--The effect of habitat structural complexity on avian diversity.



Avian species composition also changed greatly between plots. Plantation and especially clear-cut plots were dominated by more typical open grassland species such as Vesper Sparrows (*Poocetes gramineus*) and Mountain Bluebirds (*Sialia currocoides*) or by species more general in their use of habitats, such as Yellow-rumped Warblers (*Dendroica audoboni*) and Pine Siskins (*Pinus spinus*). Conversely, mature spruce-fir and riparian areas, in addition to supporting a large number of siskins, supported many Golden-crowned Kinglets (*Regulis satrapa*), Townsend's Warblers (*Dendroica townsendii*), and Swainson's Thrushes (*Hyoleichla ustulata*). Fox Sparrows (*Passerella iliaca*), Warbling Vireos (*Vireo gilvus*), MacGillivray's Warblers (*Oprornis tolmiei*), and Wilson's Warblers (*Wilsonia pusilla*) also showed increased abundances in these mature forest areas. We will concentrate on these seven mature forest species.

High percent cover, especially at the 0.5m to 1.5m levels, was of major importance to Fox Sparrows and Wilson's Warblers. This cover, in conjunction with upper strata cover was also important to Townsend's Warblers. The other four species were more common in areas with many large trees or high percent canopy cover.

The ability to characterize each species' habitat requirements more specifically was variable (Table 2). Increasing abundance on plots with high shrub and low canopy (0.5-1.5m) cover, many large diameter (50+cm dbh) stems, and few stems less than 2 cm dbh accounted for 56% of the variation in Fox Sparrow abundance. Occurrence of

Swainson's Thrushes on high elevation plots with many 25-50 cm dbh stems and high snag basal area accounted for 82% of the variation in their numbers. Townsend's Warblers were primarily found on plots with high percent cover 8-25m above ground, high shrub and low canopy cover, and few large stems. These variables explained 63% of the variation in Townsend's Warbler abundance. Combining high elevation plots with high shrub cover and many snags with dbh greater than 30 cm accounted for 76% of the variation in Wilson's Warbler abundance. The reliance of Warbling Vireos on plots with high canopy (25+m) and upper (8-25m) stratum cover, and plots with low tree basal area explained 63% of the variation in their abundance. MacGillivray's Warblers appeared most dependent upon old growth stands since 91% of the variation in their abundance was accounted for by occupation of plots with many large (50+ cm dbh) stems, and many snags greater than 30 cm dbh. These warblers were also found on plots with *increasing* snag basal area, even though this variable is negative in the equation. Golden-crowned Kinglets were primarily found on plots with many large and medium diameter stems (25-50 cm and 10-25 cm dbh). This, in combination with increasing abundance on plots with high tree basal area, explained 75% of the variation in kinglet abundance.

The inclusion of snag variables in the regression equations of Swainson's Thrushes, MacGillivray's and Wilson's warblers is interesting since these species are not known to directly rely upon dead trees. The abundance of these species also had a strong positive

Table 2.--Predictive equations of individual species' habitat requirements.

SPECIES	EQUATION <sup>a</sup>	R <sup>2</sup>
Fox Sparrow	-1.80 + 1.17 (%COV 0.5-1.5m) + 5.36 (STEMS 50+cm) - .081 (STEMS < 2cm)	.56
Swainson's Thrush	-21.39 + 4.18 (STEMS 25-50cm) + 6.59 (ELEV) + 1.04 (SNAG B.A.)	.82
Townsend's Warbler	-18.09 + 11.37 (%COV 8-25m) + 10.26 (%COV .5-1.5m) - 40.97 (STEMS 50+cm)	.63
Wilson's Warbler	-12.23 + 0.99 (%COV .5-1.5m) + 8.18 (ELEV) + 2.74 (SNAGS > 30cm)	.76
Warbling Vireo	0.61 + 222.35 (%COV 25+m) + 14.77 (%COV 8-25m) - 1.43 (BASAL AREA)	.63
MacGillivray's Warbler	-1.45 + 61.43 (STEMS 50+cm) - 2.98 (SNAG BA) + 19.31 (SNAGS > 30cm)	.91
Golden-crowned Kinglet	0.16 + 28.47 (STEMS 25-50cm) + 7.49 (STEMS 10-25cm) - 2.43 (BASAL AREA)	.75

<sup>a</sup> Equations predict abundance in number of birds per 5 hectares

relationship with the measured snag variables (Table 3). Fox Sparrows and Townsend's Warblers also had moderately significant positive relationships with the number of 30+ cm dbh snags and snag basal area (Table 3). The abundances of Warbling Vireos and Golden-crowned Kinglets were not responsive to either snag variable, however, they tended to increase in plots with higher snag values. Townsend's Warblers and Golden-crowned Kinglets responded more to snag basal area, whereas, all other species were more responsive to snag numbers (Table 3).

The apparent reliance of these open nesting species on snags can be accounted for by examining the relationship of the snag variables to percent cover and stem variables. All correlations between the snag variables and cover or stem measures are positive, and 10 out of 24 are significant at  $p < .10$  (Table 4). This indicates that as the number or basal area of snags increased so did the live cover and stem variables. Snag basal area was most directly linked to upper strata cover and stem variables, while the number of snags greater than 30 cm dbh primarily reflected shrub cover and the occurrence of large stems (Table 4).

#### Discussion and Management Recommendations

The major drawback of this study is that it represents data collected over only one year. In addition, the precise habitat used by individuals of a given species was not quantified. Instead, vegetation was sampled along the census transect irrespective of bird occurrence. Studies such as Johnston's (1977) in which the location of an individual bird was used as the center of the vegetation plot may quantify a species' specific habitat requirements more accurately, for example, by delimiting nesting and foraging habitat. These

types of studies can also discriminate habitat use in relation to species' annual cycles, whereas we provide only one measure of habitat use for the breeding season as a whole. In terms of avian community management, however, such precise documentation of habitat use may not be necessary because cost effective management practices are, as of yet, not exact enough to provide seasonally variable habitats for each stage of the annual cycle. Despite the apparent drawbacks of our study we generated highly predictive models of habitat requirements.

At the community level, the structural diversity of the habitat greatly influenced avian diversity. Similarly, avian density increased from plantation to managed to mature forest plots in southern Sweden (Nilsson 1979). In our study, even if density does not vary in accordance with structural complexity, avian species composition does. The more intensely managed plantation and clear-cut plots did hold viable bird populations, but they were composed of more typical grassland or generalist species, not in need of active management to ensure their prosperity. Conversely, the structurally complex mature forests not only supported a richer avian community, they supported a distinct avian community, composed of species with narrow habitat requirements that would be adversely effected by intensive timber management techniques. These results lead us to recommend habitats be managed for increased structural complexity. Special effort should be made to provide for substantial shrub, low canopy and mid-canopy cover development. This is in contrast to recommendations by Kilgore (1971) and Anderson (1979) stating that shrub cover is unimportant.

Our species specific habitat recommendations (Table 5) stress the importance of one or two

Table 3.--Relationship of bird abundance to snag variables.

SPECIES	NUMBER <sup>a</sup>	NUMBER OF SNAGS			SNAG BASAL AREA		
		r	N	P	r	N	P
Fox Sparrow	13	.550	19	.01	.272	19	NS
Swainson's Thrush	106	.405	19	.10	.358	19	NS
Townsend's Warbler	246	.233	19	NS	.369	19	.10
Wilson's Warbler	23	.600	19	.001	.336	19	NS
MacGillivray's Warbler	121	.724	19	.001	.375	19	.10
Golden-crowned Kinglet	241	.093	19	NS	.197	19	NS

<sup>a</sup> Total number of sightings during study period



Table 4.--Relationship of percent cover and stem counts to snag variables.

VEGETATION MEASURE	SNAG BASAL AREA		NUMBER OF SNAGS	
	r	p <sup>a</sup>	r	p <sup>a</sup>
Percent Cover 25+m	.099	NS	.041	NS
Percent Cover 8-25m	.406	.10	.250	NS
Percent Cover 2.5-8m	.568	.01	.401	.10
Percent Cover 1.5-2.5m	.338	NS	.472	.05
Percent Cover .5-1.5m	.282	NS	.460	.05
Stems 50+ cm dbh	.348	NS	.618	.001
Stems 25-50 cm dbh	.242	NS	.347	NS
Stems 10-25 cm dbh	.494	.05	.084	NS
Stems 5-10 cm dbh	.637	.001	.238	NS
Stems 2-5 cm dbh	.514	.02	.308	NS
Stems < 2 cm dbh	.194	NS	.216	NS
Live Tree Basal Area	.547	.02	.254	NS

<sup>a</sup> Sample size for all correlations is 19

plant characteristics. We must emphasize that although these are the characteristics of prime importance to each species, they alone do not constitute a given species' habitat. Instead, the recommended habitat must be maintained in conjunction with typical cover and stem counts in all strata of natural forests. In making the

following recommendations we have averaged the important habitat variables per bird species found on the three plots where the abundance of a given bird was highest. Therefore, we present vegetative attributes of the preferred habitat of each species.

Fox Sparrows and Wilson's Warblers were most dependent upon shrub and low canopy (0.5-1.5m) cover, preferring from 40% to 65% of this stratum covered. Wilson's Warblers primarily inhabited high altitude plots, and Fox Sparrows preferred the occurrence of large stems in addition to shrub cover. Swainson's Thrushes preferred high elevation plots with 170 live stems, 25-50 cm dbh, per hectare. Less extensive shrub and low canopy cover (25-50%) was important to Townsend's Warblers possibly because of the importance of upper (8-25m) stratum cover. This warbler prefers areas with 5% to 25% upper level cover, but we recommend providing the full 25% since we most commonly observed this species in the upper foliage. In accordance, Mannan and Meslow (1983) stressed the importance of grand fir (*Abies grandis*) canopy cover for Townsend's Warblers in Oregon. Townsend's Warblers were not dependent upon grand fir in our study but appeared more closely tied to Douglas fir (*Pseudotsuga menziesii*), thus pointing to the importance of structural not taxonomic characteristics of the vegetation in determining bird use. Warbling Vireos also preferred areas with 5% to 25% upper level cover and less than 5% canopy (25+m) cover. This preference for less than 5% canopy

Table 5.--Characteristics of species specific preferred habitat.

SPECIES	PREFERRED VEGETATION	SNAG CHARACTERISTICS	
		Basal Area <sup>1</sup>	Number <sup>2</sup>
Fox Sparrow	40-65% cover .5-1.5 m 23 stems 50+ cm dbh/ha	2.92	87
Swainson's Thrush	High Elevation 170 stems 25-50 cm dbh/ha	2.92	87
Townsend's Warbler	25-50% cover .5-1.5m 5-25% cover 8-25m	1.39	17
Wilson's Warbler	40-65% cover .5-1.5m High Elevation	2.92	87
Warbling Vireo	< 5% cover 25+m 5-25% cover 8-25m	1.56	23
MacGillivray's Warbler	35 stems 50+ cm dbh/ha	10.93	101
Golden-crowned Kinglet	130 stems 25-50 cm dbh/ha 610 stems 10-25 cm dbh/ha	6.81	23

<sup>1</sup> m<sup>2</sup>/ha  
<sup>2</sup> number/ha



cover is somewhat misleading, since none of our plots had over 5% canopy cover. MacGillivray's Warblers were most dependent upon the presence of large (50+cm dbh) stems, possibly reflecting the intercorrelation of this variable with shrub and low canopy cover. MacGillivray's Warblers were always observed in association with thick shrub cover in our study and by Morrison (1981). Golden-crowned Kinglets were not associated with low stratum cover, but instead preferred plots with 130 stems 25 to 50 cm dbh, and 610 stems 10 to 25 cm dbh per hectare. This is in accordance with our observations that kinglets primarily utilized upper foliage strata. In addition, this species was primarily confined to the upper elevation spruce-fir sites.

Taking the results for all species together, we can make a more holistic recommendation for maintaining populations of these species through the breeding season. The ideal site would provide 75+% ground cover, 50% to 65% shrub cover, 25% cover 8 to 25m above ground and 5% canopy cover. In addition, larger stems should predominate, specifically: 610 stems 10 to 25 cm dbh, 170 stems 25 to 50 cm dbh and 23 to 35 stems greater than 50 cm dbh per hectare should be provided. Clumping of these stems would allow for increased shrub development in the open areas and provide a more heterogeneous habitat able to support a higher diversity of species (*sensu* Roth 1976). This recommended habitat matches well with the known foraging habitat of these species during the breeding season in western Montana (Ramsden et al. 1979) and we also feel it would provide adequate nest sites. Water also appeared necessary for Fox Sparrows and MacGillivray's Warblers. These species were always found in close association with riparian thickets. Warbling Vireos and Swainson's Thrushes also preferred such areas. In accordance, we recommend stream-side and associated upland areas be given maximum protection from non-selective timber harvesting.

We cannot over emphasize the importance of percent cover and number of larger diameter stems to this community of birds, however, to the manager our precise recommendations may be difficult to implement. Therefore, we present values for more easily quantified snag variables which are associated with the preferred habitat of these bird species (Table 5). We must stress that snags, per se, do not make suitable habitat for these species but the structure of the living forest associated with the given number and basal area of snags does.

The preferred values for the snag measures are variable between species but two distinct groups are apparent. Townsend's Warblers, Warbling Vireos, and Golden-crowned Kinglets were associated with lower snag numbers and basal areas than were the other species. It is these three species that primarily depend upon upper strata foliage, hence exceedingly high snag numbers directly reduce their foraging and nesting substrate. Conversely, the other species are associated with very high snag values and depend primarily on shrub and low canopy foliage. This relationship is expected since more snags result in

a more open canopy and hence greater shrub development. Based on these conflicting requirements we propose two management alternatives. First, manage for intermediate snag numbers. A figure of 60 snags greater than 30 cm dbh per hectare or a snag basal area of approximately 2.0 m<sup>2</sup>/ha would be reasonable. Second, manage for high snag levels (80-90 snags >30 cm dbh, basal area of 4.0-5.0 m<sup>2</sup>/ha), but provide for a patchy snag distribution. This would allow good canopy development in some areas and good shrub development in others. We prefer this recommendation because overall avian diversity would be higher per stand and individual species density would not be lower than stands managed at intermediate snag levels.

The decision of which snag measure to use is also dependent upon bird species. Snag basal area is most indicative of upper strata cover and absence of small diameter stems. Therefore, it is most precisely related to the habitat requirements of Townsend's Warblers, Warbling Vireos, and Golden-crowned Kinglets in this study. The number of snags indicates presence of large diameter stems and shrub cover. Accordingly, the species depending upon these habitat variables (MacGillivray's and Wilson's warblers, Swainson's Thrush, Fox Sparrow) are more closely related to this snag measure. Number of snags greater than 30 cm dbh proved to be a better predictor of bird abundance, on the whole, than snag basal area and we therefore recommend its use, when dealing with a primarily shrub inhabiting community such as the one in this study.

These recommended snag densities are very high in comparison to studies concerned with habitat requirements of secondary cavity nesters (Evans and Conner 1979, Cunningham et al. 1980). However, the recommended stocking rate of lodgepole pine (*Pinus contorta*) in the northwest is 1500 stems per hectare, hence our highest snag density only requires 7% of the stems to be dead. Cavity nester studies also recommend that snags be in the 40 to 60 cm dbh size range, whereas, our recommendations are based on all snags greater than 30 cm dbh, which could inflate our recommendations. Although we did not monitor snag use by cavity nesters, we feel that these smaller snags may be used by bark gleaners and probers as foraging substrates (see also Brawn et al. 1982) and hence their inclusion in management recommendations is warranted.

Given that our study plots included several different coniferous species of managed and unmanaged stands, it is surprising that the relationships between cover, stem, and snag variables were so high. Since snag production depends on tree species (McComb and Muller 1983) a more precise estimate of required snag density could be gained by examining these relationships in each forest type separately. Utilizing such relationships to manage forests capable of perpetuating required snag levels will provide habitat suitable, not only for cavity nesters, but for sensitive open nesting species as well.



## Acknowledgements

Richard L. Hutto, David Manuwal, B. Riley McClelland, and Sidney Frissell provided helpful suggestions throughout the course of the field season and aided in the early formulation of these ideas. Peter Stickney aided in field identification of vegetation. Russell P. Balda made valuable comments during the preparation of the manuscript. Joane Itami is thanked for drafting Figure 1., and Colleen Sanford is thanked for proofreading the final draft.

## Literature Cited

- Anderson, S.H. 1979. Habitat structure, succession, and bird communities. In: Management of North Central and Northeastern Forests for Non-game Birds (R.M. DeGraaf and K.E. Evans, eds.). USDA For. Serv. Gen. Tech. Rep. NC-51. pp9-21.
- \_\_\_\_\_. and H.H. Shugart, Jr. 1974. Habitat selection of breeding birds in an East Tennessee deciduous forest. *Ecol.* 55:828-837.
- Balda, R.P. 1975. Vegetation structure and breeding bird diversity. In: Proc. Symp. on Mgmt. of Forest and Range Habitats for Non-game Birds. USDA For. Serv. Gen. Tech. Rep. WO-1. pp59-80.
- Brawn, J.D., Elder, W.H., and K.E. Evans. 1982. Winter foraging by cavity nesting birds in an Oak-Hickory forest. *Wildl. Soc. Bull.* 10:271-275.
- Cunningham, J.B., Balda, R.P., and W.S. Gaud. 1980. Selection and use of snags by secondary cavity-nesting birds of the ponderosa pine forest. USDA For. Serv. Res. Pap. RM-222. 15pp.
- Emlen, J.T. 1971. Population densities of birds derived from transect counts. *Auk.* 88:323-342.
- Evans, K.E., and R.N. Conner. 1979. Snag management. In: Management of North Central and Northeastern Forests for Non-game Birds (R.M. DeGraaf and K.E. Evans, eds.). USDA For. Serv. Gen. Tech. Rep. NC-51. pp214-225.
- Grosenbaugh, L.R. 1967. REX- Fortran 4 system for combinational screening or conventional analysis of multivariate regressions. USDA For. Serv. Res. Pap. PSW-44. 47pp.
- Hagar, D.C. 1960. The interrelationships of logging, birds, and timber regeneration in the Douglas fir region of northwestern California. *Ecol.* 41:116-125.
- Harvey, S. and T. Weaver. 1979. The avifauna of six Montana vegetation types. *Proc. Mont. Acad. Sci.* 38:36-42.
- James, F.C. 1971. Ordinations of habitat relationships among breeding birds. *Will. Bull.* 83:215-235.
- \_\_\_\_\_. and N.O. Wamer. 1982. Relationships between temperate forest bird communities and vegetation structure. *Ecol.* 63:159-171.
- Johnston, R.F. 1977. Composition of woodland bird communities in eastern Kansas. *Bull. Kansas. Ornith. Soc.* 28:13-18.
- \_\_\_\_\_. 1979. Replication of habitat profiles for birds. *Kansas Univ. Mus. Nat. Hist. Occ. Pap.* 82:11pp.
- Kilgore, B.M. 1971. Responses of breeding bird populations to habitat change in a giant sequoia forest. *Am. Midl. Nat.* 85:135-152.
- MacArthur, R.H. and J.W. MacArthur. 1961. On bird species diversity. *Ecol.* 42:594-598.
- Mannan, R.W. and Meslow, E.C. 1983. Habitat selection by Townsend's Warblers in forests of northeastern Oregon. Paper presented at the 53<sup>rd</sup> annual meeting of the Cooper Ornithological Society. Albuquerque, NM. 19-22 May, 1983.
- Manuwal, D.A. 1968. Breeding bird populations in the coniferous forest of western Montana. MS. Thesis, Univ. of Mont. 176 pp.
- McClelland, B.R. 1979. Influences of harvesting and residue management on cavity-nesting birds. In: Environ. Conseq. of Timber Harvesting in Rocky Mtn. Coniferous Forests. USDA For. Serv. Synopses of Technical Papers. Sept. 11-13, 1979, Missoula, Mt.
- \_\_\_\_\_. and S.S. Frissell. 1975. Identifying forest snags useful for hole-nesting birds. *Jour. For.* 73:414-417.
- \_\_\_\_\_. , Fischer, W.C. and C.H. Halvorson. 1978. Habitat management for hole-nesting birds in forests of western larch and Douglas fir. *Jour. For.* 77:480-483.
- McComb, W.C. and R.N. Muller. 1983. Snag densities in old-growth and second growth Appalachian forests. *J. Wildl. Manage.* 47:376-382.
- Morrison, M.L. 1981. The structure of western warbler assemblages: analysis of foraging behavior and habitat selection in Oregon. *Auk.* 98:578-588.
- Nilsson, S.G. 1979. Effect of forest management on the breeding bird community of Southern Sweden. *Biol. Cons.* 16:135-143.
- Ramsden, D.J., Lyon, L.J., and G.L. Halvorson. 1979. Small bird populations and feeding habitats--western Montana in July. *Amer. Birds.* 33:11-16.
- Roth, R.R. 1976. Spatial heterogeneity and bird species diversity. *Ecol.* 57:773-782.
- Smith, K.G. and J.A. MacMahon. 1981. Bird communities along a montane sere: Community structure and energetics. *Auk.* 98:3-28.
- Stamp, N.E. 1978. Breeding birds of riparian woodlands in south-central Arizona. *Condor.* 80:64-71.
- Webb, W.L., Behrend, D.F., and B. Saisorn. 1977. Effect of logging on songbird populations in a northern hardwood forest. *Wildl. Mongr.* 55:6-36.
- Whitmore, R.C. 1975. Habitat ordination of passerine birds of the Virgin river valley, southwestern Utah. *Will. Bull.* 87:65-74.



# Nest Boxes as a Coppery-Tailed Trogon Management Tool<sup>1</sup>

Wendy A. Hakes<sup>2</sup>

---

Abstract.--Thirty nest boxes designed for Coppery-tailed Trogons (*Trogon elegans*) were observed in the Huachuca Mountains of southeastern Arizona from 1979-82. No trogons used them, but 7 vertebrates did. This study indicates nest boxes may not be an important management tool for trogons, but may be useful for other North American hole-nesters.

---

## INTRODUCTION

The Coppery-tailed Trogon, a cavity-nesting bird, breeds in southeastern Arizona and Mexico. Approximately 100 trogons arrive in Arizona each April to occupy the pine-oak woodlands adjacent to the riparian habitats of the Chiricahua, Huachuca, Santa Rita, and Atascosa Mountains (Taylor 1980).

The human interest in Coppery-tailed Trogons is great--approximately 25,000 bird-watchers visit Arizona each year to see trogons and other birds unique to southeastern Arizona (Taylor 1980). The trogon population in Cave Creek Canyon of the Chiricahua Mountains is the most accessible and the most frequently visited by birders. Trogons, apparently, will not re-nest during a season if their eggs are destroyed.<sup>3</sup> Concern about harassment of the birds and resulting nest failures prompted the U.S. Forest Service to prohibit the use of tape recorders to attract wildlife in Cave Creek Canyon since this disturbs breeding trogons.

Nest boxes have been used as a management tool for many North American vertebrates where there is believed to be a deficiency of natural cavities (Schemnitz 1980). Providing artificial nest structures resulted in an increase in breeding density of several species (Strange, et al. 1971; Hamerstrom, et al. 1973). This study was undertaken to determine if nest boxes could be

used as a management tool to increase the population of Coppery-tailed Trogons in Ramsey and Sunnyside Canyons in the Huachuca Mountains. A secondary objective was to gain additional information about the effects of competition, predation, and human disturbance on trogon nesting success.

I gratefully acknowledge the help given by the following people: J. Anderson for initiating this study; S. Crabtree, S. Peckham, and Boy Scout Troop 700 for building boxes; R. Taylor for his suggestions; the staff of the Ramsey Canyon Preserve, the Arizona Nature Conservancy, and United States Forest Service for their cooperation and assistance; bird-watchers and students for their field observations; J. Anderson, J. Dunning, J. Hardison, P. Krausman, S. Mills, and R. Taylor for identifying box contents; and D. Fuller, T. Huels, W. Mannan, and W. Shaw for editing suggestions.

## METHODS

Thirty nest boxes were built to conform to the average dimensions of known trogon nests (table 1, fig. 1).<sup>3</sup> Three-quarter inch pine and fir were used to provide adequate insulation (Kibler 1969). A traditional square and an octagonal design were used. The 8-sided shape made the boxes more tree-like in appearance. The outside surfaces were painted with a brown non-toxic paint to decrease the conspicuousness of the nest boxes. They were lined with an inch of dry grass and leaves and this lining was changed each season.

Twelve boxes were erected in Ramsey Canyon in 1979 at junctions of the main canyon with side canyons. Previous studies indicated that these locations are attractive nest sites for trogons.<sup>3</sup> The remaining 18 boxes were erected in 1980 and had smaller entrance holes to limit access to predators (table 1). The 30 boxes were placed at heights ranging from 14-26 feet. Predator deterrents were put on 4 boxes after evidence of use

---

<sup>1</sup>Paper presented at the snag habitat management symposium. [Northern Arizona University, Flagstaff, June 7-9, 1983].

<sup>2</sup>Wendy A. Hakes is a senior in Wildlife Ecology, University of Arizona, Tucson, Ariz.

<sup>3</sup>Taylor, R. C. 1978. Preliminary report: the distribution, population and breeding biology of the coppery-tailed trogon in Arizona. Unpublished report.



Table 1.--Dimensions of Coppery-tailed Trogon nest boxes.

Box	Dimension	Measurement --(inches)--
1-30	depth	16.0
1-30	interior	5.5-6.0
1-30	exterior	6.3-6.8
1-12	entrance hole	3.5
13-22	entrance hole	2.5
23-30	entrance hole	2.4

by Ringtails (*Bassariscus astutus*) increased (fig. 2). The boxes were checked every 2-3 weeks from early April to mid-August and the contents were examined after the young trogons in natural cavities had fledged. In 1982, questionnaires were given to bird-watchers at the Ramsey Canyon Preserve to supplement these observations. Birders were asked to provide information such as the activity, location, sex, and age of trogons in Ramsey and Sunnyside Canyons.

No Coppery-tailed Trogons nested in the boxes during the 4-year study, although 1 male did investigate a box in Ramsey Canyon.<sup>4</sup> The populations in both canyons fluctuated slightly between years but did not increase. Ramsey Canyon had an average of 2 males and 1 female, and Sunnyside Canyon's population averaged 5 males and 3 females.<sup>5</sup>

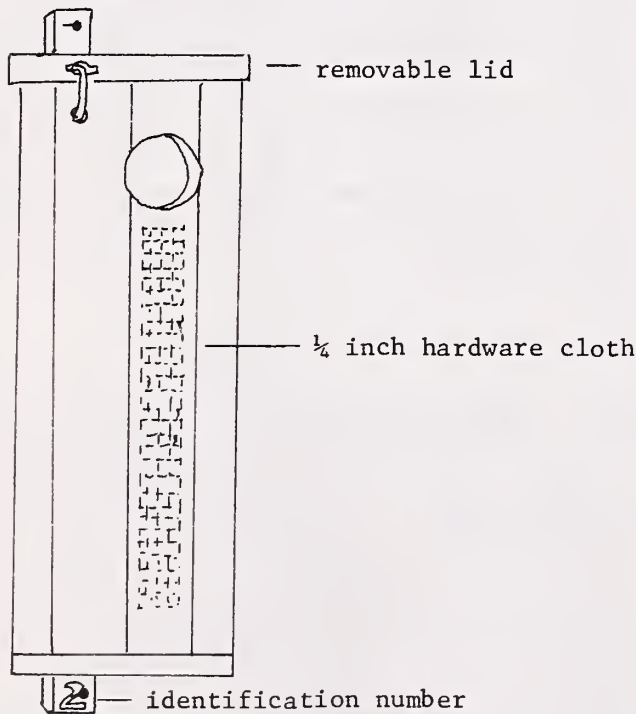

Figure 1.--Coppery-tailed trogon nest box.

<sup>4</sup>Rule, Virgil. 1982. Personal conversation. The Arizona Nature Conservancy, Tucson, Ariz.

<sup>5</sup>Taylor, R. C. 1982. The coppery-tailed trogon in Arizona, 1982. Unpublished report.

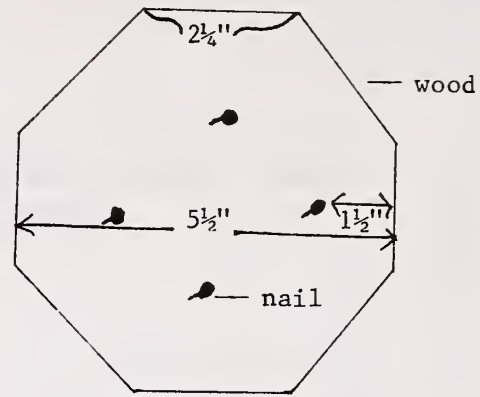

Figure 2.--Predator deterrent.

#### Use of Boxes by Other Animals

Although apparently not attractive to trogons, the boxes were used by several other birds: Flammulated Owls (*Otus flammeolus*), Whiskered Screech-Owls (*O. trichopsis*), Ash-throated Flycatchers (*Myiarchus cinerascens*), and Eastern Bluebirds (*Sialia sialis*) nested in the boxes (table 2). In 1982, Northern Flickers (*Colaptes auratus*) used 2 boxes as dump sites to lay extra eggs in.

The most frequent mammalian use of the nest boxes was roosting by Ringtails. Arizona Gray Squirrels (*Sciurus arizonensis*) also nested in at least 1 box.

#### DISCUSSION

Numerous variables could explain why Coppery-tailed Trogons did not use the nest boxes. These factors include statistical chance, population dynamics, entrance hole size, location within territories, competition, predation, human disturbance, nest tree status, physical attributes of location, height, and an abundance of natural nest sites.

The lack of use by trogons possibly is due to statistical chance. Compared with the number of natural nest cavities, the number of nest boxes is very small and the lack of use by the few nesting trogons simply may be due to chance. The population dynamics of Coppery-tailed Trogons in the United States may also be a contributing factor to the lack of use of the boxes. The Arizona population of trogons is small and is at the edge of its range. As such, this population may already be reproducing at its maximum potential. This idea appears to be supported by the presence of unmated males every year in all 4 mountain ranges.

The small entrance holes (2.4 and 2.5 inches) of 18 of the boxes may have discouraged use by trogons. These holes were at the low end of the range of hole sizes Taylor recorded for 38 natural nests. Only 2 nests have been recorded in the United States with holes under 3 inches in diameter.<sup>5</sup>

Table 2.--Use of Coppery-tailed Trogon nest boxes in Ramsey and Sunnyside Canyons, 1979-82.

Species	1979	1980	1981	1982	Total <sup>1</sup>
Coppery-tailed Trogon	0	0	0	0	0
Flammulated Owl <sup>2</sup>	0	1	0	0	1
Whiskered Screech Owl <sup>2</sup>	1	0	0	0	1
Northern Flicker	0	0	0	2	2
Ash-throated Flycatcher <sup>2</sup>	0	0	1	1	1
Eastern Bluebird <sup>2</sup>	0	0	1	0	1
Ringtail <sup>3</sup>	0	3	5	4	8
Arizona Gray Squirrel <sup>2</sup>	0	0	2	1	2
Invertebrates	6	10	14	13	23
Investigated/roosted	1	16	8	9	20
Total	8	24	23	25	28

<sup>1</sup>Number of boxes used in 4 years.

<sup>2</sup>Boxes used for nesting.

<sup>3</sup>Boxes used for roosting.

In Sunnyside Canyon, most of the boxes were placed in areas occupied by trogons. Successfully breeding trogons keep other trogons out of their territories and often re-use previously used nest cavities. Consequently, other trogons may not have had a chance to investigate the nest boxes and the territorial pair continued using an old site. The logical solution would be place the boxes outside of trogon territories, but in Sunnyside Canyon, all suitable habitat appears to be occupied.

Competition between Coppery-tailed Trogons and other species for nesting cavities may have contributed to the lack of nest box use by trogons. Steele (1966) recorded a pair of trogons preempting a Northern Flicker pair from a cavity with 2 entrances. In 1982, I watched a male trogon drive a Sulphur-bellied Flycatcher (*Myiodynastes luteiventris*) from a cavity where the female trogon was incubating. Similar interactions between this cavity-nesting flycatcher and trogons have been observed in southeastern Arizona.<sup>3</sup> A Whiskered Screech Owl was found roosting in a cavity previously used as a nest site by trogons and this species also roosted in the nest boxes. The other species that used the boxes also represent potential competitors for nest or roost sites, and, in some instances, the competitor may also be a predator. Heavy use of the nest boxes by Ringtails may present a threat to the trogons. However, I have no first-hand evidence of predation on Coppery-tailed Trogons.

Bent (1960), Steele (1966), and Taylor<sup>6</sup> recorded nest failures due to human disturbances, such as nest photography, harassment, and shooting. Both Ramsey and Sunnyside Canyons are heavily used areas for multiple purposes. However, in this study, there was no evidence of human activities influencing trogon use of natural

cavities and, consequently, there is no reason to assume it affected their potential use of the nest boxes.

As secondary cavity-nesters, Coppery-tailed Trogons use existing cavities instead of excavating their own nests. Most natural nests are found in dead and dying trees<sup>5</sup>, because it is easier for woodpeckers, the original excavators, to drill in the softer wood (Kilham 1971; Conner, et al. 1976) that is a result of aging. I do not believe, however, that the placement of the nest boxes in live trees discouraged trogon use.

The physical attributes of the locations of the boxes does not seem to have been an important factor in the lack of use by trogons. All of the nest boxes were situated in habitat that was similar to that in which trogons nest and therefore presumably were suitable locations. The nest boxes were placed within the know range of heights for natural nests and consequently this should not have discouraged use.

A final point that should be stressed is the possibility that the availability of natural cavities is not a limiting factor in Arizona Coppery-tailed Trogon populations. The possibility also exists that the trogons find artificial nest cavities unsuitable for reasons we have not yet identified.

#### CONCLUSIONS

Coppery-tailed Trogons did not use any of 30 available nest boxes in 4 years. However, 5 bird species, 2 mammal species, and numerous invertebrates did use them. Nest boxes do not appear to have much potential as an important management tool for Coppery-tailed Trogons in the United States. Protection of trogon habitat no doubt is the most important management strategy (Pratt 1979).

<sup>6</sup>Taylor, R. C. 1981. The coppery-tailed trogon in Arizona, 1981. Unpublished report.



LITERATURE CITED

- Bent, A. C. 1964. Life histories of North American cuckoos, goatsuckers, hummingbirds, and their allies. 244 p. Dover Publications, Inc., New York, NY.
- Conner, R. N., O. K. Miller, Jr., and C. S. Adkisson. 1976. Woodpecker dependence on trees infected by fungal heart rot. The Wilson Bulletin 88: 575-581.
- Hamerstrom, F., F. N. Hamerstrom, and J. Hart. 1973. Nest boxes: an effective management tool for kestrels. Journal of Wildlife Management 37: 400-403.
- Kibler, L. F. 1969. The establishment and maintenance of a bluebird nest-box project: a review and commentary. Bird-Banding 40: 114-129.
- Kilham, L. 1971. Reproductive behavior of yellow-bellied sapsuckers. I. Preference for nesting in Fomes-infected aspens and nest hole interrelations with flying squirrels, raccoons, and other animals. The Wilson Bulletin 83: 159-171.
- Pratt, J. 1979. Exploiting the trogon. Arizona Wildlife Views 22: 11.
- Schemnitz, S. D., ed. 1980. Wildlife management techniques manual. 686 p. The Wildlife Society, Washington, D. C.
- Steele, E. 1966. Arizona's mystery bird. Audubon 68: 167-170.
- Strange, T. H., E. R. Cunningham, and J. W. Goertz. 1971. Use of nest boxes by wood ducks in Mississippi. Journal of Wildlife Management 35: 786-793.
- Taylor, C. 1980. The coppery-tailed trogon: Arizona's "bird of paradise." 48 p. Borderland Productions, Portal, Ariz.

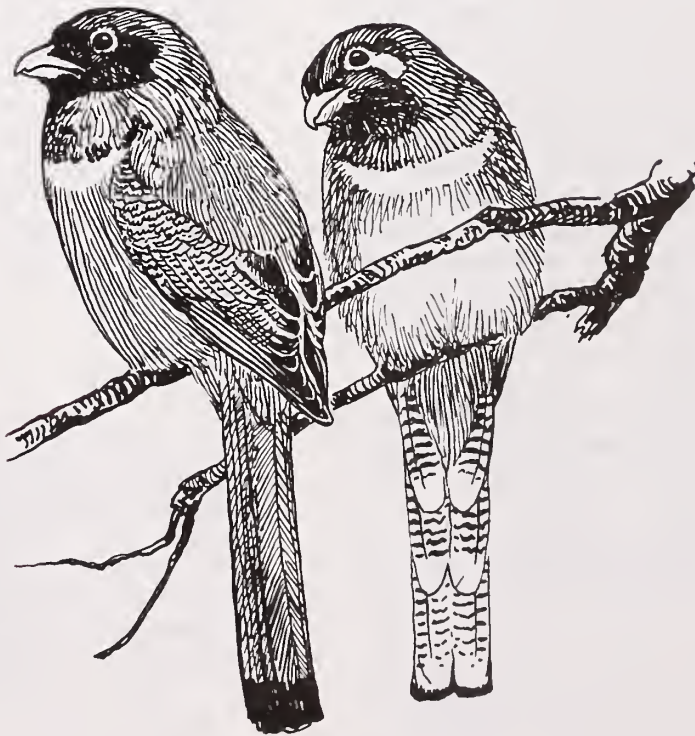

# Artificial Trees for Primary Cavity Users<sup>1</sup>

Thomas C. Grubb, Jr.<sup>2</sup>, Daniel R. Petit<sup>2</sup>, and Dennis L. Krusac<sup>3</sup>

---

Abstract.--Downy woodpeckers (*Picoides pubescens*) excavated roosting cavities in artificial trees constructed of polystyrene "beadboard." In several studies completed and now in progress we have shown that this species of primary cavity user accepted artificial snags placed in mature deciduous woodland and in a 12-year-old clearcut area of a deciduous forest. Males of this species apparently preferred taller snags and excavated farther up on a snag of a given height than did females.

---

## INTRODUCTION

Primary cavity users are animals such as woodpeckers which only roost and nest in cavities they themselves have excavated. This group will not use artificial boxes for roosting or nesting. By contrast, secondary cavity users routinely roost and nest in previously-existing cavities, often those abandoned by woodpeckers. Because this second group uses artificial nest cavities (i.e. nest boxes), they have been the subject of considerable basic and applied research (e.g. Franz 1961; Perrins 1979). Of particular interest to forest managers is the fact that populations of secondary cavity nesting birds can be increased by providing nestboxes to the point where they keep their woodland in leaf while neighboring tracts without nestboxes become defoliated by large numbers of insects (Bruns 1960).

The primary cavity nesting woodpeckers, heretofore beyond the reach of intense management practice, provide nesting sites for the secondary cavity users, but also directly exert important pressure on forest insects (MacCambridge and Knight 1972). Unfortunately, current silvicultural practices often dictate removal of dead and dying trees, precisely those required by woodpeckers. Here, we review recent work suggesting that artificial trees composed of polystyrene "beadboard" warrant consideration as a potential tool for basic and applied research on primary cavity users. We relate 1) a test of the attractiveness of artificial snags placed in a mature deciduous woodlot, 2) an

investigation of the height of artificial snags preferred by the downy woodpecker (*Picoides pubescens*) and 3) results of a project now in progress concerning artificial trees as a means of restocking woodpeckers into a 12-year-old clearcut.

We thank D. Aseltine, R. Blenker, T. Berner, C. Cummins, D. E. Donley, D. Feicht, A. Marshall, Wm. D. Peters, A. W. Peterson, K. E. Petit, C. Petrovic, L. Reichhardt, G. Sattler, M. Stanley and A. Thompson for technical assistance. The research was supported by funds provided by the USDA Forest Service, Northeastern Forest Experiment Station, and administered by J. D. Gill.

## ARTIFICIAL TREES IN MATURE DECIDUOUS WOODLAND

From November 1979 through September 1980, we made 50 polystyrene cylinders available to the woodpeckers wintering and breeding in a 65-ha deciduous woodland in north-central Ohio. We first drilled a 3-cm diameter hole 80 cm longitudinally through the middle of each of the cylinders measuring 242 cm long and 22 cm in diameter. We then slid each cylinder down over a metal post driven into the ground in the experimental woodlot. Each cylinder was coated with brown latex paint in an effort to mimic tree color. The cylinders were spaced approximately 75 m apart in a grid pattern.

Results of this study are detailed elsewhere (Peterson and Grubb 1983) and will only be summarized here. Over the 11-month period during which we monitored the cylinders weekly, we found 51 cavities excavated in 42 of the 50 trees; nine trees exhibited two cavities each. The size and constancy of the cavity dimensions (table 1) indicate that of the seven woodpecker species known to breed and/or winter in Ohio, only the downy woodpecker used the cylinders. While downy woodpeckers were sighted near the cavities by day, and several were found roosting in cavities during night inspections, no other woodpecker species was so associated with the artificial snags. Perhaps, this result was to be expected as only the downy wood-

---

<sup>1</sup>Paper presented at the Snag Habitat Management Symposium, Northern Arizona University, Flagstaff, June 7-9, 1983.

<sup>2</sup>Thomas C. Grubb, Jr. and Daniel R. Petit are, respectively, Professor and Graduate Research Associate of Zoology, The Ohio State University, Columbus, Ohio 43210.

<sup>3</sup>Dennis L. Krusac is Wildlife Biologist, USDA Forest Service, 1 Pinchot Place, Athens, Ohio 45701.



Table 1.--Dimensions of 51 cavities excavated in artificial trees by downy woodpeckers.

Parameter	Mean	SD
Cavity depth <sup>1</sup> , cm	17.1	4.2
Distance from cylinder top to entrance hole <sup>1</sup> , cm	38.1	24.6
Entrance area <sup>2</sup> , cm <sup>2</sup>	17.0	5.2
Diameter of cavity <sup>3</sup> , cm	10.1	1.0

<sup>1</sup>Measured from the lower lip of the entrance hole.

<sup>2</sup>Entrance area =  $\pi(\frac{1}{2} \text{ entrance height}) \times (\frac{1}{2} \text{ entrance width})$ .

<sup>3</sup>Measured from the inner edge of the lower lip of the entrance hole.

pecker, among the seven Ohio species, is known to accept natural snags as small as our cylinders (Thomas et al. 1979).

We found indications that downy woodpeckers made seasonal adjustments in the character of their cavities. Entrances to cavities dug in summer (April-September) were randomly oriented; those entrances of cavities fashioned in winter (November-March) were non-randomly oriented with a statistically significant mean vector of 72°. As the cylinders were all of homogeneous composition and were all positioned vertically, such potentially causal factors as tree lean and heterogeneous composition can be discounted. We conclude that, in winter, the woodpeckers excavated their cavities to face away from the prevailing southwesterly winds.

The second property of cavities that varied with time of year was their depth. Cavities excavated in winter were significantly deeper than those dug in summer. Over winter and summer taken together there was a significant negative correlation between temperature (°C) and cavity depth (cm;  $y = -0.31x + 20.8$ ;  $r = -0.75$ ;  $P < 0.01$ ).

Although no woodpeckers bred in the artificial-tree cavities, we tallied 30 nests of secondary cavity nesters in the cylinders, two nests of the Carolina chickadee (*Parus atricapillus*) and 28 nests of the house wren (*Troglodytes aedon*).

From this initial project with artificial trees we concluded that one primary cavity using species, the downy woodpecker, readily accepted polystyrene as a roost-hole substrate, and apparently even preferred this substance to the natural snags from which they moved to the cylinders. Downy woodpeckers are the smallest woodpecker in Ohio, and we hypothesized that other species might require larger cylinders.

#### PREFERRED SNAG HEIGHT IN THE DOWNY WOODPECKER

Having established that downy woodpeckers, at least, would accept artificial trees as surrogate snags, we felt it important for future studies of a manipulative nature to ascertain the preferred height of snags to be used as excavation sites by

individuals of this species. The sexes of this species have different foraging techniques, possibly to reduce intersexual competition for food resources (Williams 1975), so the question arose as to whether males and females might reduce competition by excavating on different sized snags, or at different heights on the same size snag. Accordingly, we conducted an experiment in which downy woodpeckers were given a choice among different sized snags as an excavation site.

Grubb (1982) presents a detailed report of procedures and results. Briefly, 16 trios of snags were set out in Ohio woodlots during October-December 1980. Each trio consisted of cylinders 121, 242 and 363 cm in length placed randomly in the formation of an equilateral triangle with sides of 3 m. We checked each trio daily until we found a cavity, defined as any excavation deeper than 10 cm, and noted the sex of the downy woodpecker flushed from or seen in the vicinity of the cavity.

Of 16 birds monitored, 10 dug cavities in the intermediate (242-cm) cylinders, a significant departure from random choice. The small sample size prevented statistical confirmation of the apparent choice by females of snags shorter than those chosen by males. Nevertheless, while one female and no males chose 121-cm snags, five males and no females dug in the tallest (363 cm) snags. Furthermore, in the cases where males and females both dug in the same, intermediate, sized snags, males excavated significantly closer ( $\bar{x} = 31 \pm 4$  cm,  $N = 6$ ) to the top of a cylinder than did females ( $\bar{x} = 131 \pm 19$  cm,  $N = 4$ ).

We concluded from this snag-choice experiment that downy woodpeckers, as a species, apparently preferred about 2.5-m-high cylinders in which to fashion cavities, and that artificial trees of this height might be most effective in subsequent investigations. We also concluded that our sample, while a small one, suggested that the sexes of this woodpecker species in Ohio might be reducing competition for cavity sites in ways previously unsuspected. With our initial studies demonstrating an acceptance of about 2.5-m cylinders as cavity sites by *P. pubescens*, we felt prepared to attack the question of whether surrogate snags could be used to accelerate recolonization of this species into recently clearcut areas of deciduous forest.

#### ARTIFICIAL TREES IN A CLEARCUT

During 1982-83, we investigated the important question of whether artificial trees can accelerate recolonization of clearcut habitat by primary cavity users. We emphasize at the outset that this project is currently in progress (Petit and Grubb, in preparation), so results presented here will be preliminary in nature.

In September 1982, we located two 12-year-old clearcut tracts of deciduous trees in Wayne National Forest, Ohio. Both plots were approximately 10 ha in area with a southerly exposure and slope of 20-30°. In one of these two matched clearcuts, we erected 99 artificial trees in a 9 x 11 grid



matrix with 16 m between adjacent trees in the same grid line. We had previously determined that downy woodpeckers readily accept surrogate snags square rather than round in cross section. Because square "trees" are cheaper to fabricate and easier to handle, we used 20- x 20- x 242-cm artificial trees in this study of clearcuts.

During the study to date, we have been monitoring cavity construction in the area with the surrogate snags, censusing woodpecker populations in the control and experimental plots at biweekly intervals, and recording woodpecker-caused mortality of the larvae of red oak borers (*Enaphalodes rufulus*) in the two plots. The red oak borer is an important pest in eastern deciduous forests. We planned to determine whether any increased presence of woodpeckers, correlated with the addition of artificial snags, might also be correlated with increased mortality of this insect. At the time of this writing, nesting behavior of primary and secondary cavity users is just commencing. During the coming summer months, we will monitor reproductive activity in the artificial trees.

As of April 1983, woodpeckers excavated cavities in 17 of the 99 artificial trees in the experimental clearcut. As before, the dimensions of the cavities indicate that all have been made by downy woodpeckers. Our experimental plot is bordered by mature forest on two sides. The pattern of artificial trees with cavities (fig. 1) suggests that the downy woodpeckers colonized the clearcut

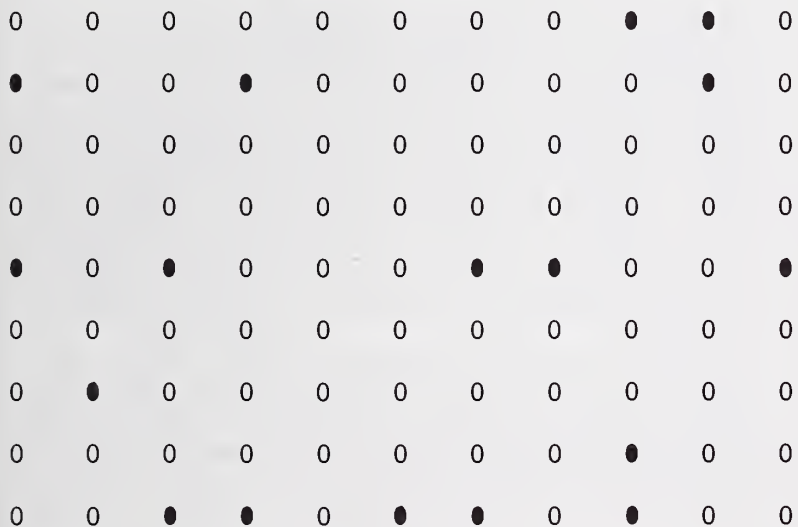

Figure 1.--The grid matrix in which 99 artificial trees were arranged within a 12-year-old clearcut in September 1982. The distance between adjacent trees in each row was 16 m. By April 1983, downy woodpeckers had excavated cavities in surrogate snags marked by blackened circles.

gradually from the surrounding woodland. Only 3 of the 35 central cavities (9%) contained cavities. During the course of the winter, a maximum of 6 downy woodpeckers were tallied in the experimental plot and a maximum of 3 birds of this species occurred in the control plot. As censusing is still being conducted, we do not yet have a final statis-

tical determination of whether downy woodpeckers were more dense in the clearcut.

Red oak borers were found in September 1982 by locating their exit holes in red oak saplings. By April 1983, 11 of the 148 borers (7.4%) had been preyed upon by woodpeckers in the experimental area and 11 or 86 (12.8%) had been eaten by woodpeckers in the control plot. Thus, it appears that the increase in downy woodpecker numbers in the experimental site had no effect on the mortality of this boring insect. Red oak borers have a two-year life cycle. By their second winter, they have bored so deeply into the stems of trees that they are probably invulnerable to attack by downy woodpeckers. Red oak borers in Ohio have synchronized life histories so that almost all adults emerge in odd-numbered years (Donley and Acciavatti 1980). Thus, almost all the borers we monitored during the 1982-83 winter were at the deeply-imbedded stage inaccessible to downy woodpeckers. Periodically, we encountered the larger hairy woodpecker (*Picoides villosus*) on both plots. Birds of this species may have been responsible for the borer mortality we did record.

Although a detailed analysis awaits the conclusion of our field work, we tentatively conclude that downy woodpeckers will colonize a recently clearcut area if they are provided with artificial substrate for digging their cavities. We also conclude that such increased presence of this woodpecker species has no impact on the level of red oak borers during the insects' second winter. The question remains open whether downy woodpeckers attracted to a clearcut by artificial snags might cause significant mortality to red oak borers during the insects' first winter when each larva is smaller and is lying dormant just beneath the bark surface, well within the range of foraging downy woodpeckers.

#### DIRECTIONS OF FUTURE RESEARCH

Artificial trees may offer the opportunity for basic research on the life histories of woodpeckers. Specifically, questions such as those concerning resource limitation, territoriality and habitat selection appear open to manipulative testing with surrogate snags. However, before this tool can have wide application, two obstacles must be overcome. First, we must discover why no downy woodpeckers have yet nested in the cavities they have constructed in artificial trees. On the premise that adequate surfaces for the birds' drumming behavior have been previously lacking, we are currently evaluating the effect of plywood resonating boards affixed to the polystyrene blanks now in Wayne National Forest.

The second obstacle to progress concerns why only the downy woodpecker has used artificial trees. Based on the hypothesis that the other, larger species require taller and/or larger blanks, we are collaborating with James Parker of the Naval Ordnance Station, Indian Head, Maryland in evaluating polystyrene blanks up to twice as tall and four times as great in cross-sectional area as those we have used previously.



From the perspective of applied research, it has yet to be established firmly that artificial trees can facilitate recolonization by primary cavity users of such disturbed habitats as forest clearcuts and reclaimed stripmined land. Whether surrogate snags might increase the impact of woodpecker predation on insect pests in forests also remains an open question.

#### LITERATURE CITED

- Bruns, H. 1960. The economic importance of birds in forests. *Bird Study* 7:193-208.
- Donley, D. E. and R. E. Acciavatti. 1980. Red oak borer. U.S. Department of Agriculture, Forest Service Forest Insect and Disease Leaflet 163, 7 p.
- Franz, J. M. 1961. Biological control of pest insects in Europe. *Annual Review of Entomology*. 6:183-200.
- Grubb, T. C., Jr. 1982. Downy woodpecker sexes select different cavity sites: an experiment using artificial snags. *Wilson Bulletin* 94: 577-579.
- MacCambridge, W. F. and F. B. Knight. 1972. Factors affecting spruce beetles during a small outbreak. *Ecology* 53:830-839.
- Perrins, C. M. 1979. *British tits*. 304 p. William Collins Sons & Co., London.
- Peterson, A. W. and T. C. Grubb, Jr. 1983. Artificial trees as a cavity substrate for woodpeckers. *Journal of Wildlife Management* 47:790-798.
- Thomas, J. W., R. G., C. Maser, and E. L. Bull. 1979. Snags. p. 60-71. *In* *Wildlife habitats in managed forests*. U.S. Department of Agriculture, Forest Service Agricultural Handbook 553.
- Williams, J. B. 1975. Habitat utilization by four species of woodpeckers in a central Illinois woodland. *American Midland Naturalist* 93:354-367.

# Use of Nesting Boxes on Young Loblolly Pine Plantations<sup>1</sup>

George A. Hurst<sup>2</sup>

---

Abstract.--Use of nesting boxes, 17-45 per area from 1977-83, on 2 loblolly pine (*Pinus taeda*) plantations in Mississippi was monitored from plantation age 1-7 years. Most of the use (nest attempts) was made by the eastern bluebird (*Sialia sialis*) with total use by the bluebird and the Carolina chickadee (*Parus carolinensis*) being 32%, 139 nest attempts, over the 7-year period. Bluebird use of and production in the boxes was highest at plantation age 3 and was lowest at age 7. Chickadee use began with 1 nest attempt on each plantation at age 3 (1979) and use remained low, 2 or 3 attempts/year, on 1 plantation. Attempts on the other plantation numbered 4 (1980) and 3 (1981) but increased to 10 (1982) and 8 (1983).

---

## INTRODUCTION

Southern forests are expected to produce more wood products with the increase in pine (*Pinus* spp.) production occurring on intensively managed pine plantations. Often, mature pine-hardwood forests are converted to pine plantations. Some 20.25 million ha of pine-hardwood forests might be converted to plantations (Walstad 1976). There are about 11.7 million ha of pine plantations in the South, and over 0.41 million ha are being established annually (Mann 1975, Montgomery 1983<sup>3</sup>).

After a pine-hardwood forest is clearcut the area is site prepared by chemical or mechanical methods. Chemical methods can create many snags, but mechanical methods such as tree-crush, roller-chop, or shear-rake-disk-bed destroy most existing and potential snags.

Some secondary cavity nesters will use nesting boxes, and boxes have been tried in some forest types in the South (McComb and Nobel 1981). Nesting boxes have been placed in forests in England and Europe (Franz 1961, Cambell 1968). This study

was conducted to determine use of nesting boxes on pine plantations age 1-7 years.

## STUDY AREAS

Two loblolly pine plantations near Longview (Oktibbeha County), Mississippi, in the Interior Flatwoods Land Resource Area of the Upper Coastal Plain were used (Pettry 1977). Each plantation was 65 ha in size and was located about 1.6 km apart (Hurst 1980a).

Both areas had been about 50-year-old pine-hardwood forests dominated by pine, oak (*Quercus* spp.), and hickories (*Carya* spp.). The forests were clearcut in the summer and site prepared in the fall of 1976. Site preparation consisted of shearing, windrowing, and bedding. Pine seedlings were hand-planted on a 2.1 x 2.4 m spacing or 1,922 trees/ha in March 1977.

Annual and perennial forbs, grasses, sedges, and vines were the dominant plants for 2 years with pine trees, hardwood brush, and blackberry (*Rubus argutus*) dominating the plantations thereafter (Darden 1980). Pine trees averaged 1.8 m tall after the third growing season. At the end of the sixth growing season average pine stand conditions were dbh 8.79 cm, height 5.3 m, basal area 12.6 m<sup>2</sup>/ha and stocking 1,634 trees/ha.

Both plantations were surrounded by mature pine-hardwood forests until 1978. From 1978 to 1982 a total of 583 ha of pine-hardwood forests

---

<sup>1</sup>Paper presented at the Snag Habitat Management Symposium. Northern Arizona Univ., Flagstaff, June 7-9, 1983.

<sup>2</sup>George A. Hurst, Professor, Department of Wildlife and Fisheries, Mississippi State University, Mississippi State, MS.

<sup>3</sup>Montgomery, J.M. 1983. Personal conversation. Southern Forest Institute, Atlanta, GA.



near the study areas was converted to pine plantations. Some small hayfields and pastures were in the vicinity of the study areas.

## METHODS

In March 1977, 40 wooden nesting boxes with 4 different dimensions, e.g. 10.2 x 10.2 x 20.3 cm and 12.7 x 12.7 x 20.3 cm, were placed on each plantation (Hurst et al. 1979). In addition 5 plastic milk jugs (4.55 l), which were painted white and had 3.8 cm entrance holes, were erected on each plantation (Stewart 1976). Jugs were on the plantations only in 1977 and 1978. The wooden boxes had entrance hole diameters of 3.2, 3.8, and 5.1 cm. The number of boxes on the plantations changed over the study period (Table 1). Three boxes, 15.2 x 15.2 x 38.1 cm, with 5.1 cm entrance holes, were placed on large trees on 1 pine-hardwood/plantation edge. These boxes were removed after the 1978 nesting season.

The boxes were attached to creosoted posts with a diameter of 7.6 cm and the posts were driven into the ground so that the entrance holes were about 1.37 m above ground. In 1983 some boxes were wired to pine trees and other boxes were attached to 3.81 cm diameter polyvinyl chloride pipe, which was placed over a steel rod. Both the rod and pipe were pushed into the ground and a box was clamped to the pipe.

In 1977 and 1978 the boxes were placed in 5 rows, which were about 55 m apart. The first row was about 20 m from a pine-hardwood forest. This row was removed after the 1978 nesting season. Boxes within a row were about 55 m apart. In 1979 the distance between rows and between boxes within rows was increased to about 91.4 m, and the number of rows was increased to 6 on one area and 7 on the other area. The number of rows was changed to 5 on both areas in 1981. The boxes were on an area of about 16.2 ha in 1977 and 1978, and about 34 ha in 1979-83.

Box use was monitored at 7-10 day intervals from March through August. Boxes were cleaned in February. Some vegetation was cut to improve walking conditions between boxes and to make the boxes more visible.

Creosote was poured on the lower part of posts that had active nests in 1977 and 1978. Conical metal guards were placed on some posts with active nests from 1979-83. A 5 cm wide band of Stikem<sup>R</sup> (Polymerized 1-Butene) was placed on all posts with active nests in 1979-83.

## RESULTS

Bluebirds and Carolina chickadees used a total of 114 (26%) of a possible 436 boxes over the 7-year period, based on single use of a box. Multiple use of a box by 1 or both species was 32%, 139 uses of 436 boxes.

Bluebirds used plastic jugs and wooden boxes with 3.8 and 5.1 cm holes, but they would not use boxes with 3.2 cm holes (Zeleny 1976); therefore bluebird use of acceptable boxes was 84 (30%) of 280 boxes. Multiple use of boxes by bluebirds was 102 (36%) of 280.

Bluebird production, based on number of nest attempts, number of eggs laid and hatched, and number of fledglings produced, peaked at plantation age 3 and was lowest at age 7 (Table 2). Of the 102 bluebird nest attempts 82% were successful, i.e. produced at least 1 fledgling. A total of 427 bluebird eggs was laid, of which 351 (82%) hatched and 328 (93%) of the nestlings fledged. Average clutch size was 4.5 (3-6).

Chickadees began using boxes at plantation age 3, with 1 nest attempt on each area. The number of nest attempts on plantation number 1 was 2 (1980, 1981, 1983) and 3 (1982). Plantation number 2 had 4 nest attempts in 1980, 3 (1981), 10 (1982) and 8 (1983). Twenty seven (75%) of the 36 chickadee nest attempts were successful. A total of 190 chickadee eggs was laid of which 134 (70%) hatched and 118 (88%) of the nestlings fledged. Average clutch size was 5.4 (2-7).

Chickadees used boxes with 3.2 and 3.8 cm holes and used boxes on posts, on pvc pipe, and boxes wired to trees. Chickadees began nesting in mid-March and fledging was over by late May. Bluebird nesting began in late March to early April with most fledging completed by late July. Bluebirds built their nests on active chickadee nests on 4 occasions.

Carolina wrens (*Thryothorus ludovicianus*) made 2 nest attempts in boxes on the plantation/forest edge. Wrens did not use boxes in the plantations.

Losses of eggs and nestlings were attributed to the imported red fire ant (*Solenopsis victa*) and the little black ant (*Monomorium minimum*) (Hurst 1980b). Other losses were caused by a raccoon (*Procyon lotor*) and a snake. Nest abandonment occurred sporadically but was a major cause of unsuccessful bluebird nests on plantation number 2 in 1980.

## DISCUSSION

Use of boxes on the plantations was limited to the bluebird and the chickadee. Bluebird use of boxes was 30% (single use) and 36% (multiple use) over the 7-year period, which was less than the 49% use reported for bluebird trails in 1982 (Dupree 1983). Bluebird use of the boxes was highest at plantation age 3 with major declines in use at age 6 and 7. Heard (1979) found much greater bluebird use of boxes on new clearcuts than on older plantations, age 4-8, in North Carolina. Mature pine-hardwood forests are not preferred bluebird breeding habitat so the cre-

Table 1.--Use of nesting boxes by bluebirds and Carolina chickadees in two loblolly pine plantations, Longview, Mississippi.

Year	Plantation		No. boxes by entrance hole diameter (cm)			No. boxes used <sup>1</sup>	No. times a single box was used			Use (%) of all boxes <sup>2</sup>	Use (%) by bluebirds <sup>3</sup>
	Age(Yr)	No.	3.2	3.8	5.1		1	2	3		
	1977	1	1 2	19 29	21 14	5 2	9 5	9 3	0 2	0 0	20 11
1978	2	1 2	19 22	21 21	5 1	4 4	3 0	1 3	0 1	9 9	15 18
1979	3	1 2	11 11	22 19	5 1	11 12	10 5	0 5	1 1	29 39	37 60
1980	4	1 2	8 3	22 18	0 0	10 9	9 8	1 1	0 0	33 43	41 33
1981	5	1 2	8 1	14 20	0 0	7 11	5 9	2 2	0 0	32 52	36 45
1982	6	1 2	2 1	16 16	0 0	5 15	5 13	0 2	0 0	28 88	12 38
1983 <sup>4</sup>	7	1 2	10 12	17 20	0 0	3 9	3 9	0 0	0 0	11 28	6 5

<sup>1</sup>Use was considered to be a complete nest in which at least 1 egg was laid.

<sup>2</sup>Percent use was figured on first use only, does not include multiple use of the same box.

<sup>3</sup>Bluebird use was figured for boxes with 3.8 or 5.1 cm entrance holes.

<sup>4</sup>Use was monitored only through June 1.

Table 2.--Bluebird production in nesting boxes in two loblolly pine plantations, age 1-7 years, Longview, Mississippi.

	Nest Attempts <sup>1</sup>				Eggs				Number Fledged	
	Suc.		Unsuc.		Laid		Hatched			
	1	2	1	2	1	2	1	2	1	2
	1977	6	7	3	0	33	29	22	28	22
1978	5	9	0	0	23	38	23	36	23	36
1979	7	15	5	2	45	72	34	61	27	57
1980	9	2	0	4	41	22	33	8	31	8
1981	7	8	0	2	33	45	29	38	25	34
1982	2	5	0	2	10	27	9	22	9	20
1983 <sup>2</sup>	1	1	0	0	4	5	4	4	4	4
Total	37	47	8	10	189	238	154	197	141	187

<sup>1</sup>An attempt was considered to be a complete nest in which at least 1 egg was laid. Suc=successful means at least 1 bluebird fledged. Unsuc=unsuccessful means no fledglings were produced.

<sup>2</sup>Use was monitored only through June 1.



ation of clearcuts and the addition of artificial nesting cavities benefitted this species.

Chickadees were said to be most common in mixed pine-hardwood forests, and the breeding habitat was mature woods (Hamel et al. 1982). Dickson et al. (1980) and Johnson and Landers (1982) found that chickadees had low relative abundances in loblolly-shortleaf (*P. echinata*) and slash pine (*P. elliotii*) plantations in the South. McComb and Nobel (1981) found little use of nesting boxes by chickadees in 3 mature forest types, including a pine-hardwood forest in Mississippi. Chickadee use of boxes on the pine plantations began at age 3 and remained low on 1 plantation, but increased considerably on the other plantation, 10 nest attempts, at age 6. Perhaps Carolina chickadee populations can be increased by nest box programs in loblolly pine plantations (Dahlsten and Copper 1979) and provide some insect control (Evans and Conner 1979).

The reason other secondary cavity nesters did not use the boxes on the plantations might be explained as follows. First, most of this part of Mississippi is still in mature, mixed-type forests, which have no apparent lack of snags/cavities. Also, there are active nesting box programs in the area. Lack of suitable nesting boxes was another reason for limited use of plantations. The great crested flycatcher (*Myiarchus crinitus*) used nesting boxes on loblolly pine plantations age 5-7 in Louisiana<sup>4</sup>. Suitable flycatcher boxes were on these study areas only at plantation age 1 and 2. Vegetative conditions were unacceptable to the tufted titmouse (*Parus bicolor*), a species that prefers deciduous woods to pine (Hamel et al. 1982). Carolina wrens used boxes placed on the mature pine-hardwood forest/plantation edge but not boxes in the dense vegetation on the plantation. Perhaps the lack of a woodland canopy was the limiting factor (Hamel et al. 1982).

Vegetative conditions changed rapidly in the pine plantations affecting the plant community surrounding the boxes. Use of nesting boxes should be determined throughout a short, 25-35 years, rotation and following various intermediate silvicultural treatments, such as pre-commercial thinning and controlled burning.

#### LITERATURE CITED

- Cambell, B. 1968. The Dean nestbox study, 1942-1964. *Forestry* 41:27-46.
- Dahlsten, D.C., and W.A. Copper. 1979. The use of nesting boxes to study the biology of the mountain chickadee (*Parus gambelli*) and the impact on selected forest insects. Pages 217-260 in J.G. Dickson, R.N. Conner, R.R. Fleet, J.C. Kroll, and J.A. Jackson eds. The role of insectivorous birds in forest ecosystems. Academic Press NY, 381pp.
- Darden, T.L., Jr. 1980. Bird communities in managed loblolly-shortleaf pine stands in east-central Mississippi. M.S. Thesis, Dept. Wildl. and Fish., Mississippi State Univ., 117pp.
- Dickson, J.G., R.N. Conner, and J.H. Williamson. 1980. Relative abundance of breeding birds in forest stands in the Southeast. *South. J. Applied For.* 4:174-179.
- Dupree, D.C. 1983. 1982 nesting box report. *Sialia* 5:62-64.
- Evans, K.E., and R.N. Conner. 1979. Snag management. Pages 214-255 in R.M. DeGraaf, Tech. Coord. Proc. of the Workshop management of Northcentral and Northeastern forests for nongame birds. USDA For. Serv., Northcent. For. Exp. Stn., St. Paul, MN. Gen. Tech. Rep. NC-51. 268pp.
- Franz, J.M. 1961. Biological control of pest insects in Europe. *Annu. Rev. Entomol.* 6:183-200.
- Hamel, P.B., H.E. LeGrand, Jr., M.R. Lennartz, and S.A. Gauthreaux, Jr. 1982. Bird-habitat relationships on Southeastern forest lands. USDA Forest Serv., Southeastern For. Exp. St., Asheville, NC Gen. Tech. Rep. SE-22. 417pp.
- Heard, J.L. 1979. Utilization of three age classes of pine monoculture by breeding bluebirds in North Carolina. M.S. Thesis. North Carolina State Univ., Raleigh. 45pp.
- Hurst, G.A., R.C. Warren, and M.Y. Grant. 1979. Nesting box trails on clearcut pine plantations. *Sialia* 1:46-51.
- \_\_\_\_\_. 1980a. Eastern bluebird production in nesting boxes in pine plantations. *Proc. Ann. Conf. S.E. Assoc. Fish and Wildl. Agencies* 35:100-105.
- \_\_\_\_\_. 1980b. Possible predation by ants on nestlings in nesting boxes. *The Mississippi Kite* 10:3-4.
- Johnson, A.S., and J.L. Landers. 1982. Habitat relationships of summer resident birds in slash pine flatwoods. *J. Wildl. Manage.* 46:416-428.
- Mann, W.F., Jr. 1975. Progress and trends in artificial regeneration. *For. Farmer Manual* 34:48-50.
- McComb, W.C. and R.E. Nobel. 1981. Nest-box and natural-cavity use in three mid-south forest habitats. *J. Wildl. Manage.* 45:93-101.
- Pettry, D.E. 1977. Soil resource areas of Mississippi. *Miss. Agric. & For. Exp. Stn., Info. Sheet No. 1278.* Miss. State Univ. 4pp.
- Stewart, P.A. 1976. Plastic jugs for nesting bluebirds. *Inland Bird Banding News* 48:66-68.
- Walstad, J.D. 1976. Weed control for better southern pine management. *Weyerhaeuser Co. For. Pap. No. 15.* Hot Springs, AR. 44pp.
- Zeleny, L. 1976. The bluebird: How you can help its fight for survival. *Ind. Univ. Press,* Bloomington, IN. 170pp.

<sup>4</sup>Robert Hamilton, School of Forestry and Wildlife Management, Louisiana State Univ., Baton Rouge, LA.



# Use of Nest Boxes in Ponderosa Pine Forests<sup>1</sup>

Jeffrey D. Brawn<sup>2</sup> and Russell P. Balda<sup>3</sup>

---

**Abstract.** Use of nest boxes by secondary cavity nesting birds was assessed on 3 study plots in northern Arizona's ponderosa pine forests from 1980 to 1982. Sixty boxes were installed on each of the 8.0 ha plots. Box use as nest sites increased, overall, from 5% to 31% during the 3 breeding seasons. Differences in % use between plots were related to the availability of natural nest sites in snags. To date, 6 species have nested in the boxes. Nest attempts were 73% successful. The employment of nest boxes as a management tool may become more viable if current trends in land use practices persist.

---

## INTRODUCTION

All organisms have certain requirements that must be satisfied in order to survive and reproduce. The habitat requirements of non-game birds have received considerable attention with much recent work focusing on the interaction between timber management and avian habitat needs (e.g. USDA For. Serv. 1980).

An especially large amount of research has been devoted to cavity nesting birds and their relationships with snags, i.e. dead or dying trees. Such research is abundant because: (1) cavity nesters are a diverse group of birds; (2) many aspects of cavity nester habitat needs are relatively specific and easily quantified; and (3) the reliance of cavity nesters on snags renders them vulnerable to certain land use practices. Investigations of many aspects of cavity nesting bird biology have been performed including; types of snags used for nesting (Connor and Adkisson 1977, Scott 1978, Cunningham et al. 1980); densities of snags suitable for support of viable populations (Balda 1975, Scott 1979); and use of snags as foraging substrates (Brawn et al. 1982). These studies have clearly demonstrated, by either experimental or descriptive analyses, the critical importance of snags to cavity nesters. Moreover, virtually all research has supported the notion that strict silvicultural management of forests is selective against snags, and that density of snags and/or nest holes is a good predictor of cavity nester densities.

The objective of alleviating the negative impact of certain silvicultural practices on cavity nesters has generated several management options. These options include: (1) retention of a certain density of suitable (i.e. large enough) snags on a managed stand (Balda 1975, Scott 1978); (2) letting a certain amount of a stand mature to or remain in old growth conditions (Hardin and Evans 1977); (3) creation of snags by either routing out holes (Carey and Sanderson 1981), killing trees (Bull et al. 1980), or fungal inoculation; and (4) installation of nest boxes.

The first two of the above options are likely the best in terms of a holistic approach to the maintenance of cavity nester populations; however, certain factors are becoming increasingly serious which may, unfortunately, mitigate their use in the future. Projected demands for wood fiber and resources (i.e. land) available to meet these demands are likely to result in an increasingly intense level of silvicultural management on many forests (Gould 1980). In addition, and perhaps as important, the ever increasing public demand for fuelwood is having a dramatic impact on the "life expectancy" and density of snags (Scott et al. 1980).

Interestingly, most research on cavity nesters has dealt with primary cavity nesters (PCNs); i.e. species which are able to excavate their own nest and roost holes. A tacit assumption of such studies has been that if PCNs are provided for, then the species which are unable to excavate, or secondary cavity nesters (SCNs), will also be accommodated. Whereas this assumption is intuitively sound, it has resulted in a general avoidance of research on the last of the aforementioned management options for cavity nesters, i.e. nest boxes.

Nest boxes have been widely used in Europe for much of the 20th century (Bruns 1960, von Haartman 1971). Boxes have generally maintained populations of SCNs in habitat which would otherwise be unsuitable. In certain instances the results have been dramatic, and many-fold increases in SCN breeding densities have

---

<sup>1</sup>Paper presented at the snag habitat management symposium. [Northern Arizona University, Flagstaff, June 7-9, 1983].

<sup>2</sup>Jeffrey D. Brawn is a Research Assistant at the Department of Biological Sciences, Northern Arizona University, Flagstaff, Ariz.

<sup>3</sup>Russell P. Balda is a Professor of Biology, Department of Biological Sciences, Northern Arizona University, Flagstaff, Ariz.



been recorded (von Haartman 1956, 1971). Commercial forests in much of Europe are intensively managed and it is likely that the presence of boxes has prevented local extirpations of many SCNs.

In North America, nest boxes have been employed on a relatively small scale. Generally, their use has been limited to game species or selected non-game species such as Eastern Bluebirds (*Sialia sialis*) (Pinkowski 1977). Certain workers have, oddly, resisted the idea of nest boxes as a management option in North America (Miller and Miller 1980). A typical objection to boxes is that they furnish only one of the resources which snags offer, i.e. unused holes for SCNs. This consideration is valid but does not diminish the utility of boxes as part of the solution to effective cavity nester management.

If boxes are to be used as an effective management tool in North America it will be necessary to have baseline data concerning their use. Prior to the present study, no large-scale nest box programs for non-game birds have been conducted in western coniferous forests (Smith 1980). This paper will report on some of the results of a study designed to assess the efficacy of nest boxes in ponderosa pine forests. The objectives of this study were:

- (1) to determine if SCNs will utilize nest boxes in ponderosa pine forests;
- (2) to monitor the success of SCNs that breed in boxes; and
- (3) to determine the cost of a nest box program.

Other aspects of this study such as effects of boxes on SCN populations, SCN habitat selection, and management recommendations will be reported on elsewhere.

## METHODS AND MATERIALS

Field work was conducted on 3 study plots, all located within the USFS Beaver Creek Watershed Project located south of Flagstaff in the Coconino National Forest, Coconino County, Arizona. Each plot covered 8-8.5 ha.

All plots consisted of ponderosa pine (*Pinus ponderosa*) dominated stands with varying densities of gambel oak (*Quercus gambeli*). Elevation of the plots varied from 2100 to 2300 m. Average annual precipitation and temperature on the Beaver Creek Watershed are approximately 64 cm and 7.2°, respectively.

The three plots differed in silvicultural histories: one plot (WS-13) was uncut for approximately 60 years; one plot (WS-8) was moderately thinned in 1974; and one plot (WS-17) was severely thinned in 1969. Silvicultural profiles of the plots are shown in table 1. Importantly, snag densities on the WS-13, WS-8, and WS-17 plots were high, medium, and low, respectively.

### Type and Installation of Boxes

Boxes used in this study were made from a mixture of concrete and wood chips and were purchased in W. Germany. The boxes were cylindrical with the following dimensions:

- Total Height - 25 cm
- Distance from Hole to Bottom - 17 cm
- Outside Radius - 10 cm

Inside Height - 21 cm  
The volume of each box was approximately 1900 cm<sup>3</sup>. Boxes were installed by hanging them on metal-wood holders which had been nailed to tree trunks.

Sixty boxes were installed on each plot; thus, a total of 180 boxes were used for this study at a density of about 7 boxes/ha. Boxes were installed during the spring of 1980.

Four types of boxes were installed on each plot; large-hole (38 mm) and small-hole (32 mm) with and without sawdust. Hole size is important because SCNs usually prefer to use nests with holes just large enough for them to pass through. The hole sizes we selected accommodate all potential avian inhabitants of the boxes in northern Arizona (raptors were not within the scope of this study). Sawdust was provided for those species which are known to partially excavate nest holes in snags and/or modify old woodpecker holes.

Boxes were spaced evenly throughout the plots using grid-markers as guides. The distribution of boxes on WS-17 was, necessarily, somewhat uneven due to the limited availability of trees suitable for hanging boxes.

### Assessment of Box Use and Breeding Success

Each box was checked at least twice during each breeding period from 1980 to 1982. Boxes found to be in use were checked more frequently.

Nesting success of box occupants was closely monitored. All boxes used during the breeding period were cleaned out during the following fall.

## RESULTS AND DISCUSSION

### Use of Boxes--Overall Response

The number of boxes used for nesting increased over six-fold between 1980 and 1982 (table 2). The greatest response to the boxes occurred on WS-8 where an average 22% contained active nests each year. The smallest response occurred on WS-13 which had only an average 7% nesting use. The use of boxes on all three plots, however, has increased each successive year. Within each plot the largest increases were between the 1980 and 1981 breeding seasons.

The build-up of box use on all plots resulted from two trends: (1) within a given species more pairs nested in boxes each year; and (2) more species used the boxes each year. For example, on WS-8 in 1980, 2 Western Bluebird (*Sialia mexicana*) and 2 Pygmy Nuthatch (*Sitta pygmaea*) nests were found, whereas in 1982 we found 9 Western Bluebird, 5 Pygmy Nuthatch, 9 Violet-green Swallow (*Tachycineta thalassina*), 1 Mountain Chickadee (*Parus gambeli*), and 1 White-breasted Nuthatch (*Sitta carolinensis*) nests.

### Use of Boxes by Species

To date, 6 species have nested in the boxes (table 3). Mountain Bluebirds (*Sialia currucoides*),



Table 1. Silvicultural Profiles of Study Plots

Plot	Tree Species	Criterion					
		Relative Density	Relative Dominance	Relative Frequency	Importance Value	Absolute Density (trees/ha)	Number of Snags
WS-17	<i>P. ponderosa</i>	81	87	69	237	57	7
	<i>Q. gambeli</i>	19	13	31	63	12	
WS-17C	<i>P. ponderosa</i>	68	65	62	198	52	9
	<i>Q. gambeli</i>	32	35	38	102	21	
WS-8	<i>P. ponderosa</i>	92	94	82	268	209	21
	<i>Q. gambeli</i>	8	6	18	32	16	
WS-8C	<i>P. ponderosa</i>	89	91	79	259	217	18
	<i>Q. gambeli</i>	11	9	21	41	19	
WS-13	<i>P. ponderosa</i>	90	86	77	253	583	39
	<i>Q. gambeli</i>	8	8	19	36	54	
	<i>J. deppeana</i>	2	6	4	11	9	

Purple Martins (*Progne subis*), and Red-breasted Nuthatches (*Sitta canadensis*) are the only local SCNs which have yet to use the boxes. Considerable inter-specific variation with regard to box use has been found. Western Bluebirds have utilized the boxes most readily on all three plots. Violet-green Swallows began to use the boxes in low numbers during 1981 on WS-8 and WS-13. In 1982 swallows nested in the boxes on WS-8 and WS-17 in relatively high densities. Bluebirds and swallows are both migratory species. Among permanent residents, box usage has been greatest with Pygmy Nuthatches, followed by Mountain Chickadees and least with White breasted Nuthatches and House Wrens (*Troglodytes aedon*). Based on preliminary data from 1983, however, White-breasted Nuthatch use of the boxes is increasing.

The relatively meager overall response on all three treatment plots in 1980 has several potential explanations. On WS-8 and, especially, WS-13, the boxes were installed rather late in relation to timing of SCN breeding due to snow conditions. In addition, the winter previous to the 1980 breeding period was, even by local standards, quite severe. Another, ongoing study on avian communities in northern Arizona

Table 2. Number of boxes with nests on treatment plots from 1980 to 1982.

Plot	Number of Boxes Used (%)*		
	1980	1981	1982
WS-17	3 (5)	13 (22)	24 (40)
WS-8	6 (10)	22 (37)	24 (40)
WS-13	0	4 (7)	8 (13)
Overall Usage	9 (5)	39 (22)	56 (31)

\*Boxes with two nests in one season are counted once.

has found that adverse winter conditions can have a distinct negative effect on bird populations (Balda et al. this volume). Finally, a period of "adjustment" may be required before all the SCNs recognize the boxes as potential nest sites. A type of social facilitation is possibly involved; that is, birds observe use of boxes by other birds and subsequently learn that the boxes are an exploitable resource. Studies concerning box use by Wood Ducks (*Aix sponsa*) have also noted a gradual increase through time in the proportion of boxes used (Doty and Kuse 1972).

The overall disparate response to the boxes on the plots is likely due, in part, to the availability of natural nest sites. The number of boxes divided by the number of excavated holes counted on snags within the plots were: WS-13, 1.2; WS-8, 1.9; and WS-17, 8.57. A correlation between these ratios and the % of SCN nests found in boxes indicated a significant positive relationship ( $r = .67$ ,  $df = 7$ ,  $P < 0.05$ ). This indicates that availability of snags and box usage are mutually dependant. If box usage continues to increase on WS-13 as it did between 1981 and 1982, however, this relationship will become less distinct. These data indicate that availability of snags may precipitate a lag in box usage but that boxes will eventually be utilized. Further research will be required to properly evaluate this matter. The question of why certain species respond to boxes more than others will be considered elsewhere (Brawn and Balda, in prep.).

#### Nesting Success of Birds Using Boxes

Overall, 73% of the nesting attempts in boxes were successful; that is, at least one nestling fledged (table 4). This success rate agrees favorably with what has been found for cavity nesters and/or temperate passerines (Nice 1957, Ricklefs 1969). Thus, it does not appear that the boxes used in this study present any particular liability to breeding birds.



Table 3. Use of boxes for nests by various SCNs between 1980 and 1982.

Species	Number of Boxes Used								
	WS-17			WS-8			WS-13		
	1980	1981	1982	1980	1981	1982	1980	1981	1982
Violet-green Swallow	0	0	5	0	4	9	0	1	1
Mountain Chickadee	0	0	1	0	2	1	0	1	2
White-breasted Nuthatch	0	0	1	0	0	1	0	0	0
Pygmy Nuthatch	0	2	2	3	5	5	0	0	2
House Wren	0	1	0	0	0	0	0	0	0
Western Bluebird*	3	10	15	3	11	9	0	2	3

\*Boxes used twice for first and second broods are counted only once.

Considerable variation between species was found in nesting success. Pygmy nuthatches had the highest nest success whereas Western Bluebird second nests were the least successful. Nesting success was approximately equal on the three plots but did vary between years. For example, overall Violet-green Swallow success was about 35% lower in 1982 than 1981. Such variation appears to be due to annual differences in spring-summer precipitation and temperature and breeding phenology (Brawn and Balda, in prep.).

The primary cause of nesting failure was abandonment of either unhatched eggs or nestlings. It is unlikely that predation on breeding adults was responsible for these abandonments since, in the cases where birds were color marked, breeding adults were subsequently observed on the plots.

Predation on eggs or nestlings occurred in only 4 out of the 110 nests (4%). This rate of predation is much lower than that reported for many cavity nesters (Ricklefs 1969). We are not certain of the identity of the predator but, based on conditions of the nests, we consider gopher snakes (*Pituophis melanoleucus*) a possibility. All the predation losses occurred on Western Bluebird second nests in 1981. Thus, no "build-up" of predation pressure has occurred on any of the plots.

Table 4. Overall nesting success of SCNs in nest boxes.

Species	Number of Nest Attempts	Number of Successful Nests (%)
Violet-green Swallow	21	12 (57)
Mountain Chickadee	7	6 (86)
White-breasted Nuthatch	2	1 (50)
Pygmy Nuthatch	18	17 (94)
House Wren	1	1 (100)
Western Bluebird		
First Nests	38	30 (79)
Second Nests	23	13 (43)
Totals	110	80 (73)

Nest parasites were not found to be an important source of nesting failure. The only nests in which we found parasites were second nests of Western Bluebirds (N = 9, 39%). The parasites were blowfly larvae of *Apaulina* (formerly *Protocalliphora*). We found no relationship between incidence of parasitism and probability of nest success or nesting mortality ( $P > 0.05$ ,  $\chi^2$ ).

#### Non-Avian Use of Boxes

Non-avian use of the boxes by vertebrates was limited. Between 1980 and 1982 we found direct evidence of only 1 mammal nest; the species was unidentified. During fall cleanout of boxes we did find several instances of leaves placed on top of old bird nests, but no animals were found. Importantly, mammalian use of the boxes has had very little effect on avian use. Other box projects, designed for birds, have had considerable mammalian use of boxes, particularly flying squirrels (*Glaucomys* spp.) (Brawn 1979)<sup>4</sup>.

#### Cost of Boxes

The cash outlay and labor necessary to start and maintain the box project have been reasonably low (table 5). The boxes, including shipping from W. Germany, cost less than \$10.00 each. The only equipment necessary to install the boxes were a ladder and hammer.

Labor needed to maintain the boxes was not excessive. To date, after 540 box-years, 2 boxes, which were struck by lightning, have had to be replaced. One other box was removed from its hanger by persons unknown and was replaced. Boxes used for nesting were cleaned out after the breeding period. Cleaning required about 1 man-hour/box.

Other workers have recommended against nest box programs because of prohibitive costs. For example,

<sup>4</sup>Brawn, J.D. 1979. The relationship of cavity nesting birds to snags in the oak-hickory forest. Unpub. Masters Thesis. Univ. of Missouri-Columbia, Columbia, Missouri.

McComb (1979)<sup>5</sup>, with regards to southeastern forests, reports 4 to 14 cavities must be present before one is used by a cavity-dependant species. Citing a cost of \$25.00/box it was determined that a minimum of \$100.00 was necessary for each active box.

Our findings, however, indicate that such caution is unwarranted in ponderosa pine forests. Our data clearly demonstrate that the costs/active box are considerably less. For example, by 1982 we found that about 1 box in 3 (on WS-8 and WS-17) were used. This does not indicate, however, that 3 boxes are needed for every one used by SCNs. Differences in territorial behavior (between species), yearly fluctuations in density of prospective breeders, climate, and habitat type are likely most responsible for much of the variation in box usage. Moreover, preliminary analysis of the 1983 breeding season indicates that box usage will again increase; thus lowering the expense of boxes in terms of cost/active nests.

### CONCLUSIONS

The results of this study demonstrate that boxes are a viable management option for SCNs in ponderosa pine habitat but that extant snag-density will markedly effect how often and what uses boxes. On stands such as WS-13 it is clear that the installation of boxes is unnecessary. On stands with few snags, boxes will be used but the response is also mitigated by structure of live vegetation. For example, we found that very open areas, like WS-17, will support fewer foliage gleaners, such as Pygmy Nuthatches, than areas like WS-8 which have higher foliage volume.

Maintenance of densities of snags sufficient to locally maintain cavity-dependant species of wildlife has been recommended by many workers. We stress that snags will always be needed in ponderosa pine forests. Many species that require snags do not use nest boxes. Boxes cannot be considered as a complete substitute for snags but should be considered as part of the solution to maintaining snag-dependant fauna. No management plan for cavity nesters should depend on only one technique or policy. An integrated approach will in the long term likely be the most effective.

Finally, our data show that many oft-cited reasons for not using boxes can be irrelevant. We found neither predation or parasitism were factors that should prohibit use of boxes. Costs in our study were not prohibitive; however, expense will be quite likely variable depending on such aspects as box design used and scale of the project. We suggest that pilot box programs be initiated in other habitat types so that the efficacy of such an approach can be assessed. In the ponderosa pine forests of northern Arizona, boxes work and cannot be ignored as an effective management option.

<sup>5</sup>McComb, W.C. 1979. Nest box and natural cavity use by wildlife in mid-South hardwoods as related to physical and microclimatic characteristics. Ph.D. Thesis, Louisiana State Univ., Baton Rouge, LA.

Table 5. Cost and labor for nest box project.

Item	Cash Outlay and/or Labor
Boxes, hangers, and shipping	\$9.30/box
Installation (transport of boxes to plot, selection of box trees, and installation)	2 man-hours/box
Maintenance (cleaning 1 time/year)	1 man-hour/box

### ACKNOWLEDGEMENTS

We thank the Federal Timber Purchaser's Association, the National Forest Product's Association, Northern Arizona University, and the Frank M. Chapman Fund for supporting various aspects of this study.

### LITERATURE CITED

- Balda, R.P. 1975. The relationship of secondary cavity nesting birds to snag densities in western coniferous forests. USDA For. Serv., Southwest Region Wildl. Hab. Tech. Bull. 1. 37 p.
- Brawn, J.D., W.H. Elder, and K.E. Evans. 1982. Winter foraging by cavity nesting birds in an oak-hickory forest. Wildl. Soc. Bull. 10:217-275.
- Bruns, H. 1960. The economic importance of birds in the forest. Bird Study 7:298-301.
- Bull, E.L., A.D. Twombly, and T.M. Quigley. 1980. Perpetuating snags in managed mixed conifer forests of the Blue Mountains, Oregon. In Management of western forests and grasslands for nongame birds. R.M. DeGraff, Tech. Coord., p. 325-336. USDA For. Serv. Gen. Tech. Rep. INT-86. Intermt. For. and Range Exp. Sta.; Ogden, Utah.
- Carey, A.B. and H.R. Sanderson. 1981. Routing to accelerate tree-cavity formation. Wildl. Soc. Bull. 9:14-21.
- Conner, R.N., and C.S. Adkisson. 1977. Principal component analysis of woodpecker nesting habitat. Wilson Bull. 89:122-129.
- Cunningham, J.B., R.P. Balda, and W.S. Gaud. 1980. Selection and use of snags by secondary cavity nesting birds of the ponderosa pine forest. USDA For. Serv. Res. Paper RM-222. 15 p.
- Doty, H.A. and A.D. Kruse. 1972. Techniques for establishing local breeding populations of Wood Ducks. J. Wildl. Manage. 36:428-435.
- Gould, N.E. 1980. U.S. timber needs and prospects for bird habitats. In Management of western forests and grasslands for nongame birds. R.M. DeGraff, Tech. Coord., p. 295-301. USDA For. Serv. Gen. Tech. Rep. INT-86. Intermt. For. and Range Exp. Sta.; Ogden, Utah.
- Hardin, K.I. and K.E. Evans. 1977. Cavity nesting bird habitat in the oak-hickory forest...a review. USDA For. Serv. Gen. Tech. Rep. NC-30. 23 p.
- Miller, E. and D.R. Miller. 1980. Snag use by birds. In Management of western forests and grasslands for nongame birds. R.M. DeGraff, Tech. Coord.



- p. 337-356. USDA For. Serv. Gen. Tech. Rep. INT-86. Intermt. For. and Range Exp. Sta.; Ogden, Utah.
- Pinkowski, B.C. 1977. Blowfly parasitism of eastern bluebirds in natural and artificial nest sites. *J. Wildl. Manage.* 41:272-276.
- Ricklefs, R.E. 1969. An analysis of nesting mortality in birds. *Smith. Contrib. Zool.* 9:1-48.
- Scott, V.E. 1978. Characteristics of ponderosa pine snags used by cavity nesting birds in Arizona. *J. For.* 76:26-28.
- \_\_\_\_\_. 1979. Bird response to snag removal in ponderosa pine. *J. For.* 77:26-28.
- \_\_\_\_\_, J.A. Whelan, and P.L. Svoboda. 1980. Cavity nesting birds and forest management. In *Management of western forests and grasslands for nongame birds*. R.M. DeGraff, Tech. Coord. p. 311-324. USDA For. Serv. Gen. Tech. Rep. INT-86. Intermt. For. and Range Exp. Sta.; Ogden, Utah.
- Smith, K.G. 1980. Nongame birds of the Rocky Mountain spruce-fir forests and their management. In *Management of western forests and grasslands for nongame birds*. R.M. DeGraff, Tech. Coord., p. 258-279. USDA For. Serv. Gen. Tech. Rep. INT-86. Intermt. For. and Range Exp. Sta.; Ogden, Utah.
- USDA For. Serv. 1980. Workshop proceedings: Management of western forests and grasslands for nongame birds. USDA For. Serv. Gen. Tech. Rep. INT-86. 535 p. Intermt. For. and Range Exp. Sta.; Ogden, Utah.
- von Haartman, L. 1956. Territory in the Pied Flycatcher, *Muscicapa hypoleuca*. *Ibis* 86:460-475.





# A Palo Verde Snag in the Sonora Desert<sup>1</sup>

Charles E. Kennedy<sup>2</sup>

---

Abstract.--Nearly constant daily use of a dead little-leaf (Yellow) palo-verde (Cercidium microphyllum) in the Sonoran, Saguaro Palo Verde Desert by 13 species of birds is discussed. The bird species are listed with some discussion regarding their behavior in the snag.

---

## INTRODUCTION

The snag being discussed here is approximately 15 feet tall, 6 inches in diameter at breast height, and has a crown spread of 12-18 feet, is hard, and has no cavities. It occurs with other typical Sonoran desert vegetation such as mesquite (Prosopis juliflora), blue palo verde (Cercidium floridum), and saguaro (Carnegiea gigantea). Shrubs in the area include creosote bush (Larrea tridentata), white thorn (Acacia constricta), and sweet acacia (Acacia farnesiana) (some of which are introduced ornamentals). Other acacias and mimosas are in the general area, but are not common near the snag. The most common shrub near the snag and within the general vicinity is burr sage (Franseria dumosa).

In addition to the saguaros (approximately one per acre) several species of cacti are present. Engelmann prickly pear (Opuntia engelmannii), jumping cholla (Opuntia fulgida), and barrel cactus (Ferocactus wislizenii) are common.

Grasses are rather uncommon. No perennial grasses have been observed. Six weeks grama (Bouteloua barbata) is a common annual grass.

Snags are uncommon in the Sonoran Desert. In a recent survey of vegetation of 2,100 acres in nearly identical Sonoran Desert type, approximately 12 miles east, no snags were observed. Occasional dead branches were seen on palo verde trees.<sup>3</sup>

The snag is at 2400' elevation. Saguaro densities increase a quarter of a mile away, only a few feet higher (2450-2500). Mesquite and palo verde are larger along the drainages. The soil type is Paleorthid, often is very hardened, and overlays Caliche (Petrocalcic). Five to eight acres west of the snag are undeveloped,

---

<sup>1</sup>Paper presented at the Snag Habitat Management Symposium. (Flagstaff, Arizona, June 7-9, 1983).

<sup>2</sup>Charles E. Kennedy is Wildlife Biologist, Coronado National Forest, Tucson, Ariz.

<sup>3</sup>Personal communication, Dr. Steve Carothers, 1983, Flagstaff, Ariz.

with native vegetation as described above (with the exception of my house--150 feet from the snag). In general, the area is only partially developed. It is an area of northwest Tucson, just west of Oracle and Orange Grove which growth skipped over. Large acreages held by a few owners prevented development.



Figure 1.--This dead palo verde has been used by nine bird species.



## DISCUSSION

### Methods

This paper is based on casual observations of the use of the snag. The observations have been made on impulse at no precise time or period of time.

A few months ago we began listing species seen in the snag and later added to this by noting what species were seen together.

### Seasonal Use and Daily Use

No obvious patterns have been detected. Seasonally, use in the spring months appears to be a little lower than summer, fall, and winter. This may be due to time spent in reproduction activities.

Daily uses are rather constant. The snag has a bird or birds more often than the rare times when it is empty.

No aggressive-intolerant behavior between species was observed. All species seem to tolerate each other. Six species were observed together at one time. Twelve individuals--four species--were observed at one time.

### Implied Behavioral Uses

Loafing appears to be the most common behavior among nearly every species. Doves, starlings, and finches rest-loaf commonly.

Cactus wrens, thrashers, gila woodpeckers, and cardinals may be resting/loafing during their visits, but stay is nearly always short. They always seem to be too busy to sit for very long.

Gambel's quail occasionally loaf and sit. Males call from tip top perches occasionally, sometimes when alone, sometimes when with a female. Up to six quail have been together loafing.

### Food and Water

Water and bird seed are available near my house, 120 feet from the snag. This may influence

Table 1.--Findings and opinions.

Bird Species	Frequency of Use
Mourning dove	Most frequent
House finch	Very frequent
Starling	Very frequent
Cactus wren	Frequent
White winged dove	Frequent (when present <sup>1</sup> )
House sparrow	Frequent
Gambel's quail	Occasional
Gila woodpecker	Occasional
Curve-billed thrasher	Occasional
Anna's hummingbird	Occasional (when present <sup>2</sup> )
Cardinal	Infrequent
White crowned sparrow	Infrequent
Boat-tailed grackle	Infrequent
Cooper's hawk	One observation-immature spring migrant

<sup>1</sup>Not present in winter.

<sup>2</sup>Observed during winter months.

the use of the snag, but since the snag was used prior to our supplying feed and water, and the presence of other available water nearby, I do not feel it has any significant effect upon the amount of use of the snag by birds.

## SUMMARY AND CONCLUSIONS

1. A snag in a partially developed Sonoran desert type is used regularly by 9 species of birds.
2. The snag has values as a loafing/resting perch for the birds.
3. Regular and scheduled observations would better identify competition and/or intolerance between species and within species, and provide precise data on seasonal and diurnal uses.
4. Persons who like to see birds and have them around, could install a dead standing tree.

# Cavities in Trees in Hardwood Forests<sup>1</sup>

Andrew B. Carey<sup>2</sup>

---

Abstract.--The effectiveness of forest management in ensuring viable populations of cavity-using wildlife will depend on the extent to which managers understand the nature of the cavity resource and the patterns of abundance of cavity trees. To gain such an understanding for Appalachian deciduous forests, I sampled 31 oak-hickory stands (47-120 years old) and 12 maple-beech-birch stands (61-206 years old). Over 4,400 trees were measured to describe the stands and more than 80 ha containing 39,000 trees were searched for cavities. Abundance of trees with cavities was highly variable even among very similar forests; much of the variability was unrelated to age, diameter at breast height (d.b.h.), site index, or other stand or topographic features. Random processes played major roles. Standing dead trees peaked at 50-70 years. Cavity tree abundance (4-9/ha in the oak-hickory, 4-17/ha in the maple-beech-birch) was lower than called for by current management recommendations. Snags (dead or partly dead trees) were more abundant than currently recommended; the value of snags in evaluating habitat is questionable. The two forest types differed markedly in the types of cavity trees, abundance of different kinds of cavities, and the types of management activities that would be appropriate.

---

## INTRODUCTION

Formation of cavities begins when a tree or part of a tree dies, is killed, or is injured. Death or injury can be due to suppression, fire, insect attack, disease, mechanical injury (from wind, snow, ice, falling trees, or other forces), or chemical injury (herbicides, acid rain, and other sources). Invasion by microorganisms sets the stage for decay causing fungi. Decayed wood may be removed by vertebrates; woodpeckers often excavate sound wood to reach columns of decay in trees. Cavities are sometimes formed without intervention by vertebrates; for

example, when a large limb is torn from a tree or when heart rot and invertebrate activity results in hollow trees or limbs (Carey and Sanderson 1981).

Because of the diverse causes of mortality and the diverse species of animals that help create cavities, cavities are formed in many species and many sizes of trees throughout the development of a forest after a regenerative disturbance. More than 60 species of Appalachian birds and mammals use cavities for nesting, roosting, escaping, loafing, eating, or caching food. And cavities in trees are integral habitat elements, necessary for maintaining populations for 23 common, widespread species in central Appalachia (Carey and Healy 1981).

Once formed, a cavity may be used by a succession of invertebrates and vertebrates. John Gill<sup>3</sup> observed the use of a black walnut

---

<sup>1</sup>Paper presented at the Snag Habitat Management Symposium, Northern Arizona University, Flagstaff, 7-9 June 1983.

<sup>2</sup>At the time the research reported was done, Carey was research wildlife biologist, Northeastern Forest Experiment Station, USDA Forest Service, Morgantown, W.Va. Currently he is research coordinator, Old-Growth Forest Wildlife Habitats Program, USDA Forest Service, 3625-93rd Ave. S.W., Olympia, Wash. 98502.

---

<sup>3</sup>Gill, J. D. 1983. Personal correspondence. USDA Forest Service, Northeastern Forest Experiment Station, University of Massachusetts, Amherst, Mass. 01003.



(Juglans nigra) in West Virginia over a 32-month period. Initially, a cavity in the tree was being used by honey bees (Apis mellifera). A pileated woodpecker (Dryocopus pileatus) excavated new openings into the tree (suggesting carpenter ants [Campanotus sp.] were also present). Two northern flickers (Colaptes auratus) fed in these openings; then a gray squirrel (Sciurus carolinensis) bore and raised a litter in the newly opened cavity while the beehive persisted. The bees and squirrels used the same entrance. The next year a fox squirrel (S. niger) raised a litter in the cavity; the same year another gray squirrel raised a litter in the cavity. Later a Virginia opossum (Didelphis virginiana) was observed in the cavity. The last use observed (May 1983) was by a fox squirrel that apparently will produce the fourth litter in the cavity. Such sequential, interspecific use of cavities is common, as is interspecific competition for cavities; Carey and Sanderson (1981) provided a brief review.

Much has been written about the characteristics and uses of cavities, trees containing cavities, and the environments of cavity trees used by various species of wildlife; recent reviews were done by Bull et al. (1980), Carey and Sanderson (1981), Conner (1978), Evans and Conner (1979), Hardin and Evans (1977), McComb and Noble (1981), Miller and Miller (1980), Miller et al. (1979), Scott et al. (1980), and Weigl (1978). Species vary in their ability to use cavities, trees, and environments according to their morphology, physiology, behavior, experience, and the presence of other species. Some species, especially secondary cavity-users are very plastic; others, especially some of the cavity excavators, are rather inflexible. For example, southern flying squirrels (Glaucomys volans) use a wide range of cavities (and sometimes other shelters) in many kinds of trees and in many different environments, but pileated woodpeckers are constrained by their size alone to excavating cavities in large trees. It is important to recognize that the cavities and trees used by a species will vary with environment and that many species use what is available, for example, hollow trees, cavities in tree butts, cavities in stumps, and cavities that provide little protection from the elements. Dennis (1969) provided some good examples. It is equally important to recognize that success in rearing litters or raising broods is partially a function of the quality of cavities and cavity trees. It is apparent that animals using poor quality cavities are much less likely to contribute to sustaining their species' population than individuals to which more secure cavities are available. It is, therefore, difficult to formulate an operational (applicable to management goals) definition of cavity or cavity tree.

A cavity is easily defined in a functional sense: a hole in a tree that provides shelter from the elements and protection from disturbance by predators and competitors. I used this functional definition to formulate an operational definition and classification of cavities from a habitat management view: a hole in a tree more than 1 m above the ground (anything lower is readily accessible to snakes and other terrestrial predators) that provides overhead shelter from precipitation (that is, an entrance not facing upward), has no cracks or openings except the entrance, and is in a tree sound enough to withstand normal winds and other mechanical forces. Hollow trees would not be deemed to contain cavities unless there appeared to be cavities in limbs; rather, hollow trees would be considered to be "escape" structures fulfilling only part of the functions of a cavity. Openings to the butt of trees, large cracks in trees, cavities in stumps, and cavities in small, fragile, rotten trees would also be excluded by the definition. Cavities could be classified by size of entrance: small, suitable for small mammals such as deer mice (Peromyscus maniculatus) and southern flying squirrels or small birds such as the black-capped chickadee (Parus atricapillus), tufted titmouse (Parus bicolor), and white-breasted nuthatch (Sitta carolinensis) (these would include cavities excavated by downy woodpeckers, Picoides pubescens); medium, such as cavities commonly used by gray squirrels or excavated by woodpeckers such as the red-bellied woodpecker (Melanerpes carolinus) and hairy woodpecker (Picoides villosus); and large, cavities that could be used by raccoons (Procyon lotor) or owls. Cavities can be cross-classified by use: mammal, with fresh gnawing or nest of leaves; bird, such as recently excavated woodpecker cavities; and bird or mammal, with no evidence of what is presently using it. Actual dimensions and the nature of the cavity entrance and the cavity tree could be used to guess how the cavity was formed and the species that might be using it; but, unless the occupant is seen, a cavity cannot be assigned to a particular species.

Most surveys of cavities in trees have concentrated on describing the cavities and cavity trees used by particular species of wildlife such as gray squirrels or pileated woodpeckers, or by groups such as woodpeckers or secondary cavity-using birds. Only a few surveys have tried to determine the abundance of cavities in deciduous forest (Boyer 1976, Dalke 1948, and Gysel 1961). My purpose in this paper is to describe the variety and abundance of cavities in second-growth hardwood forests in West Virginia, and to provide managers with a better understanding of the cavity resource.



## METHODS

### Study Areas

#### Oak-Hickory Forest

My study area was a 2-km-wide strip across the approximate center of Middle Mountain in the Monongahela National Forest in Greenbrier and Pocahontas Counties, West Virginia. The mountain is a ridge 29 km long and 2.4 to 4.0 km wide. The ridge meanders north-northeast and the flanks are dissected by narrow, steep drainages (Gill et al. 1975). The study area was 725-1,024 m in elevation and encompassed 17 mixed oak stands (53-120 years old, 303 ha), 12 pine-oak stands (47-101 years old, 324 ha), 1 white pine (*Pinus strobus*) stand (53 years old, 13 ha), and 1 pitch pine (*P. rigida*) stand (80 years old, 13 ha). The weighted (by area) average stand age was 76 years, and the average stand size was 20 ha. Site index (northern red oak) ranged from 36 to 85 with a weighted average of 43; 20 stands were classified as low quality, 10 as immature, and 1 as two-aged for timber management purposes.<sup>4</sup>

#### Maple-Beech-Birch Forest

The maple-beech-birch stands were in the Cheat Ranger District, Monongahela National Forest, in Randolph and Tucker Counties, West Virginia. Seven stands were 61-69 years old and 5.7-38.9 ha; four stands were 94-126 years old and 13.0-37.7 ha; and one stand was 206 years old and 27.5 ha. Site index for northern red oak ranged from 70 to 80. The stands were scattered and on Shavers Mountain, Backbone Mountain, McGowan Mountain, and Bickle Knob.

#### Stand Selection

The oak-hickory stands were those intersected by or located between 4 of 57 permanent, parallel transects that cross the main ridge of Middle Mountain. The 57 transects were randomly located perpendicular to the main ridge, 0.4 km apart; the starting point of each transect was also randomly located within 40 m of the Forest Service property boundary. The four transects were chosen because they were at the center of the mountain, at its widest point, and away from recently harvested or burned areas, and because of their proximity to field quarters.

The maple-beech-birch stands were chosen by examining the old stands (100+ years) listed in the district's inventory. Only stands without a record of timber improvement activities were examined. Stands that appeared to have had extensive human disturbance were

---

<sup>4</sup> White Sulphur Springs Ranger District, Monongahela National Forest. Compartment records, unpublished. White Sulphur Springs, W.Va.

avoided. Because undisturbed old stands were few in number, almost all were studied. Younger undisturbed stands were selected in the vicinity of the old stands.

Almost every stand we visited had at least minor evidence of disturbance, such as selective cutting, grapevine control, or felled trees. Many had trees of two age classes: the predominant class determined by the last harvest and a small number of trees left during the harvest. The oldest oak-hickory stands were located on ridges and poor sites; the best of the old stands had been cut. Nevertheless, the stands chosen for study are representative of the hardwood forests on upland sites in West Virginia as they exist now, but neither the oak-hickory nor the maple-beech-birch stands were a true random sample. Because of the preferential selection, minor disturbances, and bias (old stands on the poor sites), nominal statistical levels are not very meaningful, and I interpreted the results with all of the above in mind.

### Sampling Methods

#### Sampling the Forest

The point-centered quarter (PCQ) method (Cottam and Curtis 1956) was used to sample trees larger than 10 cm d.b.h. every 20 m along 3 km of each of the four transect lines on Middle Mountain and along the long axes of the maple-beech-birch stands. Additional transect lines were placed in the old stands on Middle Mountain. The distance from the PCQ point to each tree was recorded along with tree species, d.b.h., crown class (dominant, subdominant, or suppressed), number of dead branches greater than 8 cm in diameter, and vigor (good or bad depending on the condition of the crown). Other categorical (yes-no) variables were: live; exposed dead wood on trunk; sound sapwood; rot (as evidenced by branch stubs, old wounds, fire scars, broken tops, fungal conks, etc.); woodpecker feeding (as evidenced by torn bark, excavated wood, peckmarks, but not yellow-bellied sapsucker [*Sphyrapicus varius*] sapwells); and woodpecker cavities. All sampling was done during winter because deciduous trees are leafless during winter and visibility is good.

#### Map Features, Age, and Site Index

I located each oak-hickory sampling point on U.S. Geological Survey topographical maps. For each point I recorded the elevation, the relative elevation (elevation divided by the elevation of the highest point in the study area), the major aspect (sine of the aspect of at least two contour lines), and the position on the mountain slope (the distance from the point to the valley floor divided by the



distance from the ridgetop to the valley floor). Age of stand and site index were taken from Forest Service stand inventory data (see footnote 4).

## RESULTS

### Oak-Hickory Forest

#### PCQ Sample

#### Describing Trees With Cavities

I prepared for cavity-searches by doing a pilot study in maple-beech-birch stands. Eight 25- x 40-m plots were searched for cavities, and the 915 trees in the plots were cut down. Each tree was cut into sections and examined for cavities (Carey and Healy 1981). On this basis we felt we could conduct cavity-searches by examining trees from the ground with binoculars.

Cavity trees were sampled by searching 30-m wide strips centered on the transect lines. One observer walked the line while two others walked abreast of him, 15-20 m away on either side of the line. Binoculars were used to search all trees in the strip for cavities. Upon sighting a hole in a tree, the observer would attempt to find a position from which he or she could inspect the hole through binoculars to determine its potential and probable uses. Rangefinders were used to determine if borderline trees were within or outside the strip. The PCQ and following variables were recorded for each tree deemed to contain a cavity that offered a bird or mammal secure shelter: upright or pronounced lean, top intact or top broken, and number of decayed branches, stubs, or scars of branches thought to have been 8 cm or more in diameter. In addition, each tree was categorized (yes-no) as a feeding snag (extensive woodpecker feeding), an escape tree (a large hollow in the tree), or as containing a bird's cavity, a small mammal's (gray squirrel-size or smaller) cavity, and/or a large cavity. A description of each cavity found was recorded.

#### Statistical Methods

Preliminary examination of the data was accomplished using the SAS (Helwig and Council 1979) and BMDP (Dixon 1981) computer programs for summary statistics, histograms, bar charts, and scatter plots. A variety of tests of significance were used: the actual test chosen for any specific comparison was chosen to minimize violations of test assumptions. Differences reported in the text are differences that were statistically significant at  $P < 0.01$ . The relationship between the abundance of cavities and the stand and topographic characteristics was examined through regression analysis with appropriate transformations (Frane 1981).

Among 2,400 trees in the sample, the most abundant species and their mean d.b.h. were: chestnut oak (Quercus prinus), 23 cm; northern red oak (Q. rubra), 24 cm; pignut hickory (Carya glabra), 22 cm; and white oak (Q. alba), 20 cm. Twenty-four other species had relative frequencies of less than 5 percent and made up 34 percent of the trees. Only 57 trees (2.4 percent) had woodpecker cavities; the median d.b.h. of these cavity trees was 38.8 cm, whereas the median d.b.h. of all trees was 18.1 cm and only 25 percent were larger than 27.7 cm. Cavity trees tended to be dominant in the canopy (39 percent) or suppressed (42 percent). Only 19 percent of the total sample were dominants; 42 percent were codominant and 39 percent suppressed. The cavity trees were, on the average, 75 percent larger with three times more dead branches than the average tree (table 1). The proportion of trees with rot, evidence of woodpecker feeding and/or poor vigor, was also greater for trees with woodpecker cavities than for the entire sample; likewise, a greater proportion of cavity trees were dead or partly dead (table 1). The largest trees (38.2 percent of trees greater than 42.5 cm d.b.h.) were chestnut oaks; a disproportionate share of the cavities was in chestnut oaks. A even greater disproportionate share of cavities was in black locusts (Robinia pseudoacacia), most of which were suppressed (65 percent), poor in vigor (68 percent), or dead (46 percent); 89.5 percent had rot; and mean d.b.h. was 21.0 cm.

#### Strip Transect Sample

Thirty-six hectares were searched for cavities along the PCQ transect lines. This area included an estimated 19,161 trees, 235 (1.2 percent) of which were identified as containing cavities. Although the transects were remarkably uniform in tree species composition, and were not different ( $P > 0.10$ ) in mean d.b.h. and density of trees, the density of cavity trees varied between five and nine per hectare. The mean d.b.h. of cavity trees was 41 cm, almost twice the mean for the PCQ sample; 80 percent of the cavity trees were dominants (versus 19 percent of the PCQ sample). Trees containing gray squirrel cavities were larger still, averaging 50 cm d.b.h. (table 2).

The species composition of cavity trees was: chestnut oak, 44 percent; northern red oak, 19 percent; black locust, 10 percent; white oak, 9 percent; and pignut hickory, 7 percent. Ten other species also had cavities. As with the PCQ sample, a disproportionate share of the cavity trees were in chestnut oaks (104 trees, mean d.b.h. 43.4 cm) and black locusts (23 trees, mean d.b.h. 26.1 cm). Of

Table 1--Characteristics of trees with woodpecker-excavated cavities, Middle Mountain, West Virginia, 1980<sup>1</sup>

Variable	Trees with cavities	All trees
Sample size	57	2400
D.b.h. ( $\bar{x} \pm SE$ , cm)	37.9 + 1.8	21.7 + 0.2
Range in d.b.h. (cm)	13.3 - 76.0	10.0 - 105.2
Dead branches/tree ( $\bar{x} + SE$ )	0.7 + 1.2	0.2 + 0.6
Percentages of trees:		
With dead branches > 8 cm in diameter	37	9.5
Alive	68	93.8
Vigorous	60	84.0
With rot <sup>2</sup>	97	54.8
Partly dead <sup>3</sup>	74	23.0
With woodpecker feeding	91	38.7
Chestnut oak	42	30.3
Black locust	14	2.4
Northern red oak	9	15.1
White oak	9	9.9
Pignut hickory	4	11.2

<sup>1</sup>Data were collected from 600 point centered quarter sampling plots.

<sup>2</sup>As indicated by fungi, wounds on the bole, fire scars, cracks, holes, and large dead-branch stubs.

<sup>3</sup>Exposed dead wood on bole.

Table 2--Characteristics of all trees and cavity trees, both >10-cm DBH on Middle Mountain, West Virginia<sup>1</sup>

	TRANSECT				
	1	2	3	4	$\bar{x}$
Age (years) <sup>2</sup>	74	74	69	72	72
Basal area (m <sup>2</sup> /ha)	19	21	20	19	20
N/ha					
All trees	546	514	521	548	532
Cavity trees/ha	5	8	9	5	7
Average DBH (cm)					
All trees	21	23	22	21	22
All cavity trees <sup>3</sup>	39	41	42	44	41
Squirrels	51	54	48	46	50
All mammals	39	46	48	46	44
Birds	35	39	38	47	40

<sup>1</sup>Data on all trees from 600 PCQ plots; on cavity trees, from 36 ha of strip transects.

<sup>2</sup>Weighted by area of stand intersected by transects.

<sup>3</sup>Compare d.b.h.'s of all cavity trees with those below: squirrel-den trees, those probably used by some mammal, and by some bird.



the black locusts, 57 percent were suppressed and 39 percent were dead.

The 235 cavity trees contained 134 cavities potentially useful to birds, 155 to mammals, and 22 to large vertebrates (table 3); 16 percent of the trees were dead, and 12 percent were hollow. Trees containing bird cavities differed from trees containing mammal

cavities in that more were dead, more had broken tops, and their mean diameter was smaller. But 48 percent of trees with bird cavities also had mammal cavities, and 41 percent of trees with mammal cavities also had bird cavities (table 4). Trees with large cavities had a mean d.b.h. of 58.7 cm (SE = 3.2 cm); all were alive, but 23 percent had broken tops.

Table 3--Numbers, kinds, and selected features of cavity trees among all trees > 10-cm d.b.h. on transects across Middle Mountain, West Virginia

Characteristic	- - - - -TRANSECT - - - - -				Total
	1	2	3	4	
All trees (N)	4,914	4,626	4,689	4,932	19,161
Cavity trees:					
Number	46	71	77	41	235
Prevalence <sup>1</sup>	9.4	15.3	16.4	8.3	12.3
Trees <sup>2</sup> with:					
Bird cavities	28	50	35	21	134
Mammal cavities	30	39	53	33	155
Large cavities	1	6	11	4	22
Other features of cavity trees:					
Dead trees	10	14	10	3	37
Feeding snags	19	16	17	26	78
Hollow trees	6	3	5	14	28
Dead branches/live trees	1.3	1.4	1.2	1.6	1.4

<sup>1</sup>Cavity trees/1000 trees greater than 10 cm d.b.h.

<sup>2</sup>Some trees had more than one cavity. Cavities are loosely classified by potential or probable use: bird, woodpecker cavities and other cavities with entrances less than 5 cm in diameter; mammal, gray squirrel cavities and cavities with entrances less than 5 cm in diameter; large, all cavities with entrances larger than 10 cm.

Table 4--Categorical comparison of bird- and mammal-cavity trees on Middle Mountain, West Virginia

Characteristic	Mean		Range	
	Bird	Mammal	Bird	Mammal
	- - - - -Percent - - - - -			
Alive	70	95	46-86	87-97
Dead and hard	12	5	9-14	3-13
Dead and soft	8	0	0-16	-
With dead branches <sup>1</sup>	58	78	41-76	69-94
With broken tops	31	22	23-38	18-30
Hollow	14	16	2-38	5-39
With mammal cavities	48	--	35-72	-
With woodpecker cavities	50	--	36-57	-
With bird cavities	--	41	-	30-49
With gray squirrel dens	--	46	-	20-64
Cavities/tree	1.9	1.7	1.6-2.3	1.4-2.2
D.b.h. ratio <sup>2</sup>	1.8	2.1	1.6-2.2	1.9-2.2

<sup>1</sup>Dead branches were recorded as present on live trees only.

<sup>2</sup>D.b.h. of cavity trees/d.b.h. of PCQ trees.

## A Sample of Older Stands

Five stands 101-120 years old were sampled. Most were on ridges and were composed of widely-spaced older trees with a second age class of younger trees developing. These stands were similar to those on the transects in species composition, basal area, and mean tree d.b.h. (table 5). But cavity trees were less numerous and larger than those along the transects; 41 cavity trees were found, for a density of 4 per hectare. The trees averaged 46 cm d.b.h. and 31 had mammal cavities, 21 had bird cavities, and 8 had large cavities. Twelve were hollow, and 6 were dead.

## Regression Analysis

It was necessary to transform cavity tree abundance by taking the square root of the observations to achieve normality in the dependent variable. Independent variables considered were mean d.b.h., standard deviation of d.b.h. (as a measure of residual trees), tree density, position on the mountain slope, elevation, aspect, site index, and age of stand. Data were from 132 80- x 30-m plots along the transect lines. Cavity tree abundance (averages of two sampling plots) averaged 1.48 and ranged from 0.0 to 6.5. Site index averaged 56 and ranged from 36 to 80. The d.b.h. averaged 22 cm and ranged from 14 cm to 32 cm. Regression analysis using the all-possible-subsets methods indicated that the

best single predictor was d.b.h. ( $R^2 = 0.11$ ), and the two best predictors were d.b.h. and site index ( $R^2 = 0.14$ ). Additional variables raised the correlation coefficient but the coefficients of the additional variables were not different ( $P > 0.10$ ) from zero. Although the correlation coefficient of the regression on d.b.h. and site index was low, the regression was significant ( $P < 0.0000$ ). The residuals of this regression had a mean of zero, were normally distributed, and were not correlated with either independent variable or with the predicted values of the dependent variable. I, therefore, concluded that much of the variability in cavity abundance was random and could not be accounted for by topographic position, site index, or stand characteristics (age, d.b.h., variability in d.b.h., and tree density). Discrete multivariate analysis of categorical variables (tree species, forest type, d.b.h. class, etc.) was more successful but required a number of tree-specific measurements. Those results will be reported elsewhere.

## Maple-Beech-Birch Forest

### PCQ Sample

All age classes were dominated by sugar maple (*Acer saccharum*) and American beech (*Fagus grandifolia*). Yellow birch (*Betula alleghaniensis*), red maple (*A. rubrum*), American basswood (*Tilia americana*), and black

Table 5--Comparison of five older stands (101-120 years) with younger stands on transects

Characteristic	Mean <sup>1</sup> of mean		Range of mean	
	Old	Transect	Old	Transect
Age (years)	110	72	101-120	69-74
Basal area (m <sup>2</sup> /ha)	20	20	15-29	19-21
Trees/ha	596	532	516-772	514-548
Cavity trees/ha	4	7	1-9	5-9
D.b.h. (cm):				
PCQ trees	21	22	16-23	21-23
Cavity trees	46	41	39-52	39-44

<sup>1</sup>Weighted by area sampled. Five old stands were sampled by PCQ (424 trees) and by strip transects (12.3 ha) encompassing 26,421 trees. Forty-one cavity trees were found.



cherry (*Prunus serotina*) were common, but less abundant than sugar maple or American beech (table 6). Northern red oak (*Q. rubra*) and 20 other species occurred in relatively low abundance.

The 206-year age class was not different ( $P > 0.10$ ) from the 94- to 126-year age-class in mean d.b.h., tree density (PCQ distance), or dead branches per live tree. The 61- to 69-year class was different from the older classes in mean d.b.h., density, and dead branches per live tree ( $P < 0.01$ ). Note, however, the great variability among stands within the two age classes that had replicated sampling (table 6).

The number of large, dead branches per live tree and d.b.h. increased from young to old age classes. In addition, the density of large, dead branches (table 7) and the proportion of trees woodpeckers used for feeding (table 6) increased with age class.

Large, dead branches were well correlated with d.b.h. ( $r = 0.67$ ). However, the density of trees, including dead trees, decreased with age class.

#### Cavity Search

In a 44.5-ha area, 459 trees with cavities were found out of an estimated 20,181 trees. Density, prevalence, and mean d.b.h. of trees with cavities increased with age (tables 7 and 8). The percentage of cavity trees that were dead or hollow decreased with age. The percentage of trees with cavities used by mammals was consistently much larger than the proportion with cavities used by birds (table 8). Large cavities were rare: only 15 were found.

Practically all species of trees had cavities, but the relative importance of species varied with age. In the oldest stand,

Table 6--Characteristics of three age classes of maple-beech-birch forest in Randolph and Tucker Counties, West Virginia<sup>1</sup>

Characteristic	Stand age-class		
	61 to 69 years (7 stands)	94 to 126 years (4 stands)	206 years (1 stand)
Predominant species <sup>2</sup>	Sugar maple American beech Red maple	Sugar maple American beech Yellow birch	Sugar maple American beech American basswood
Trees/ha:			
Mean	542	386	374
Range	333-854	354-445	-
Median d.b.h.: <sup>3</sup>			
Mean	24	28	29
Range	19-29	25-30	-
Dead branches/live tree:			
Mean	0.45	0.72	0.88
Range	0.24-0.72	0.35-0.94	-
Percentages of trees:			
Dead	10	11	6
Partly dead	28	30	28
With rot	76	84	77
With woodpecker feeding	27	33	52
With woodpecker cavities <sup>4</sup>	3 (0-16)	2 (0-4)	14

<sup>1</sup>Based on a sample of 12 stands and 2,000 trees chosen by point centered quarters.

<sup>2</sup>Listed in order of relative importance.

<sup>3</sup>Mean d.b.h. means (and ranges): young, 28 cm (24-29 cm); old, 31 cm (29-33 cm); oldest, 31 cm.

<sup>4</sup>Ranges in parentheses; in one young stand, 16 percent of the trees were cavity trees; the other six stands averaged 1 percent.

Table 7--Cavity tree, dead branches, and dead tree density by age class of maple-beech-birch forest in Randolph and Tucker Counties, West Virginia

Characteristic (per ha)	Stand age-class		
	61 to 69 years (7 stands)	94 to 126 years (4 stands)	206 years (1 stand)
Cavity trees: <sup>1</sup>			
$\bar{x}$	9.8	10.3	13.3
SE ( $\bar{x}$ )	1.7	0.9	--
Range	4.5-16.8	7.9-11.8	--
Dead branches: <sup>2</sup>			
$\bar{x}$	247.4	283.2	327.0
SE ( $\bar{x}$ )	49.4	62.4	--
Range	102-445	124-419	--
Dead trees: <sup>3</sup>			
$\bar{x}$	55.1	40.7	22.4
SE ( $\bar{x}$ )	10.7	3.3	--
Range	15-93	32-48	--

<sup>1</sup>Area searched: 20.4 ha for 61-69; 18.1 ha for 94-126; 6 ha for 206.

<sup>2</sup>Trees examined: 1,084 trees for 61-69; 716 trees for 94-126; 200 trees for 206; dead branches were greater than 8 cm in diameter and on live trees.

<sup>3</sup>Calculated by multiplying density estimates by the proportions of sample trees that were dead and averaging among stands.

Table 8--Characteristics of cavity trees in three age classes of maple-beech-birch forest in Randolph and Tucker Counties, West Virginia

Characteristic	Age-class		
	61 to 69 years	94 to 126 years	206 years
Trees examined	10,816	7,123	2,242
Cavity trees:			
Number found	186	193	80
Prevalence <sup>1</sup>	17.2	27.1	35.7
Average d.b.h. (cm):	39.5	53.2	51.9
SE ( $\bar{x}$ ) of d.b.h.	3.0	4.8	2.4
Dead (percent)	29.1	16.0	12.5
Mammal (percent)	82.4	74.4	75.0
Bird (percent)	20.8	25.6	30.0
Large (percent) <sup>2</sup>	0.9	9.5	0.0
Escape (percent)	32.8	29.3	18.0

<sup>1</sup>Cavity trees per thousand trees.

<sup>2</sup>Cavity trees containing large cavities.



48 percent of cavity trees were sugar maple (versus 36 percent of PCQ trees), 21 percent were American beech (versus 24 percent of PCQ trees), and 16 percent were red maple (versus 6 percent of PCQ trees). Sugar maples were also predominant in the old stands but not disproportionately (37 percent versus 40 percent). But American beech was disproportionately predominant (29 percent versus 18 percent) as was American basswood (12 percent versus 7 percent). Likewise, in the young stands sugar maple was proportionately abundant and American beech disproportionately so (20 percent versus 13 percent); but eight other species were abundant (comprising more than 10 percent of cavity trees) in individual stands: Fraser magnolia (Magnolia fraseri), black locust, pignut hickory, northern red oak, white ash (Fraxinus americana), striped maple (A. pensylvanicum), yellow-poplar (Liriodendron tulipifera), and black cherry.

#### Use of Cavities

Trees with cavities used by birds were smaller with fewer dead branches, were less abundant, and were more likely to be dead, to be fed upon by woodpeckers, and to have broken tops than trees with cavities used by mammals (table 9). The d.b.h. of trees with cavities

used by birds increased with age class, but the percentage of dead trees with soft sapwood declined (table 10). Thus the number of dead branches per tree increased. The percent of bird-cavity trees used by mammals was greater than the percent of mammal-cavity trees used by birds (table 11). The d.b.h. of trees with cavities used by mammals also increased from young to old, and the percentage that were dead (hard or soft sapwood) declined. Both bird- and mammal-cavity trees averaged more than one cavity per tree (tables 10 and 11). Few of the bird- and mammal-cavity trees had large cavities. All trees with large cavities were alive and were characterized by larger-than-average numbers of dead branches, rotten branch stubs, and large branch scars. The average d.b.h. of trees with large cavities was 57.8 cm (SE = 5.5 cm); six had mammal cavities, two had bird cavities, and six were hollow.

#### Age and Variability

The young stands were much more variable in all characteristics than the old stands. Given such variability in overall tree density and d.b.h. (table 6) and the abundance of cavity trees, large dead branches, and dead trees (table 7), it is not surprising that cavity tree density and cavity abundance were not well correlated with stand age ( $r = 0.23$ ).

Table 9--Comparison of bird-cavity trees to mammal-cavity trees by age class in maple-beech-birch forests in Randolph and Tucker Counties, West Virginia<sup>1</sup>

Characteristic	Stand age-class		
	60 to 69 years	94 to 126 years	206 years
Cavity trees:			
Average d.b.h.	0.7	0.8	0.8
N/ha	0.2	0.3	0.4
Ratios of percentages: <sup>2</sup>			
Dead and hard	2.8	8.6	8.3
Dead and soft	39.0	16.0	(8/0) <sup>3</sup>
Top broken	2.8	2.4	14.0
Dead branches	0.4	0.7	0.8
Feeding	1.2	2.6	2.8

<sup>1</sup>Table values are bird values divided by mammal values.

<sup>2</sup>Hard and soft refer to sapwood; dead branches includes scars, stubs, and branches greater than 8 cm in diameter; feeding refers to trees extensively fed upon by woodpeckers.

<sup>3</sup>Among mammal-cavity trees, none was dead and soft.

Table 10--Comparison of cavity trees probably used by birds by age class of maple-beech-birch forests in Randolph and Tucker Counties, West Virginia

Characteristic	Age class		
	61 to 69 years	94 to 126 years	206 years
Cavity trees			
N/ha	33 (1.6)	49 (2.7)	24 (4.0)
Cavities/tree	1.2	1.5	1.4
D.b.h.:			
$\bar{x}$	29.0	44.2	46.0
SE ( $\bar{x}$ )	3.1	3.8	3.8
Percent of trees: <sup>1</sup>			
Dead and hard	36	43	25
Dead and soft	39	16	8
Tops broken	76	71	29
Dead branches	30	59	63
Percent use: <sup>2</sup>			
Mammal	18	22	21
Large animal	3	6	0
Escape	6	16	21
Feeding	39	53	71
Woodpeckers	39	43	21

<sup>1</sup>See Table 9 for explanation of categories.

<sup>2</sup>Escape refers to trees with hollow trunks; woodpeckers to recently excavated cavities.

Table 11--Comparison of cavity trees used by mammals by age class of maple-beech-birch forests in Randolph and Tucker Counties, West Virginia

Characteristic	Age class		
	61 to 69 years	94 to 126 years	206 years
Cavity trees:			
N/ha	159 (7.8)	147 (8.1)	61 (10.2)
Cavities/tree	1.3	1.4	1.3
D.b.h.:			
$\bar{x}$	42.3	57.1	54.4
SE ( $\bar{x}$ )	2.4	5.6	2.8
Percent of trees: <sup>1</sup>			
Dead and hard	13	5	3
Dead and soft	1	1	0
Tops broken	27	30	2
Dead branches	72	84	80
Percent use: <sup>1</sup>			
Bird	4	7	7
Large animal	0	5	0
Escape	33	43	25
Feeding	20	20	41

<sup>1</sup>See Tables 9 and 10 for explanation of categories.



## Formation of Cavities

In both the oak-hickory and maple-beech-birch forests cavity trees were, on the average, much larger than the average tree. This is expected because of the ways cavities form. Large (and old) trees develop large branches that die and the result is top rot. When small branches die the tree usually heals quickly and, even if decay organisms gain entry to the tree, the decay can be compartmentalized. Large, old trees have a greater probability than small, young trees of having been exposed to fire, wind storms, ice storms, early snowfall, falling trees, insect attack, and other injurious events that result in broken branches, broken tops, or wounds that allow decay organisms to enter the tree. In addition, it takes time for decay to spread, develop, and soften the wood. On Middle Mountain I saw evidence of small fires, wind damage, and death of large branches by natural pruning. In the maple-beech-birch study area, I observed a large amount of damage from ice storms and early snowstorms as well as natural pruning. Leaves still on trees during early snowstorms provided a large surface area that accumulated snow and caused large branches to break. But in both areas, cavities were also found in small trees, particularly black locust and other trees that were suppressed. These small trees accounted for most of the dead cavity trees, especially those with soft sapwood. As the forest develops, mean d.b.h. increases and tree density decreases. The density of dead trees in the young maple-beech-birch stands was 1.4 times the density in the old stands and 2.5 times the density in the oldest stands.

From a wildlife standpoint there are two major processes taking place. The first is the gradual suppression and death of small trees, which results in substrate available for excavation of cavities by species that use dead trees or require soft sapwood. The second process is the exposure of large trees to decay organisms. This results in top rot that provides cavity substrate for species that can excavate through sound sapwood, or can prevent callus from sealing off columns of decay formed by rotting branches. This is not to say that nonexcavators or weak excavators do not use the large, live cavity trees. Pileated woodpeckers created an amazing number of feeding excavations in live trees on Middle Mountain. Many of these were narrowed by callus formation and were used by a variety of species. Other woodpeckers also start and abandon, or create, use, and abandon cavities that are later used by other species. When large, dead branches become soft, they provide the same substrate as small, dead trees. We found very few large, dead trees in either study area. It appeared that most large, old trees died after falling during heavy winds; not while standing. Blowdown of individual trees and patches of mature trees was observed in both areas.

The density of cavity trees in the second-growth oak-hickory forest was a function of d.b.h., site index, and random processes contributing to cavity formation (fire, wind, and ice storms). Cavity abundance was variable and was not predictable from stand data and map features. Trees were more abundant, grew faster, and provided more cavities on good sites than on poor sites. None of the sites had been thinned, and it can be assumed that thinning would have reduced the number of small cavity trees.

The density of cavity trees increased with age-class in the maple-beech-birch forest. But especially in the young stands, cavity tree abundance was variable, and probably a function of early stand history--regeneration and initial stocking levels. As in the oak-hickory forest, suppressed trees were important for the development of dead cavity trees; the number of dead trees decreased with age.

The distribution of the d.b.h. of cavity trees compared to the more-or-less randomly sampled trees indicated that a majority of cavity trees were in the upper 25 percent of tree diameters. This, and my personal observations, suggests to me that a significant proportion of the cavity trees were trees carried over from the previous stand. It is hard to age trees with cavities because their cores are usually rotten; however, a small sample of increment cores did confirm that some of the cavity trees predated the regeneration harvest.

## Probable Users of Trees With Cavities

Although the density of trees with cavities in the oak-hickory forest was less than the density in the maple-beech-birch forest, a greater proportion of the oak-hickory trees were used by birds. Thus the density of bird-cavity trees was greater in the oak-hickory forest than in the maple-beech-birch forest. The proportion of cavities used by birds that were recently excavated by woodpeckers and the density of woodpecker cavities was also greater in the oak-hickory than in the maple-beech-birch forest. In both forests, bird-cavity trees were more likely to be dead and to have broken tops than were mammal-cavity trees. But this difference was more pronounced in the maple-beech-birch forest than in the oak-hickory; suggesting a greater reliance of birds on suppressed trees in the maple-beech-birch forest. In the maple-beech-birch forest a majority of live cavity trees contained small cavities formed mostly as a result of the natural pruning of branches. These cavities were suitable as dens for deer mice, southern flying squirrels, and red squirrels (*Tamiasciurus hudsonicus*). In the oak-hickory forest many cavities in live trees had been created by the feeding activity of pileated woodpeckers and other woodpeckers and



provided a variety of suitable shelters. I observed little activity by pileated woodpeckers in the maple-beech-birch stands. Likewise, the oak-hickory forest contained over four times as many large cavities as the maple-beech-birch forest. Large cavities appeared to have most often resulted from long use as dens by gray squirrels.

#### Supply and Demand of Trees With Cavities

The questions of how many cavities are enough and how many cavities would there be under "natural conditions" are difficult to answer. The number of trees with cavities that is enough depends on management objectives. Empirical evidence suggested to Sanderson (1975) that more than 1.2 good quality dens/ha would sustain huntable populations of gray squirrels. I found approximately two gray squirrel cavity trees/ha, and most trees had more than one cavity, suggesting that Middle Mountain provided a more than adequate environment for gray squirrels.

Such goals are not as easily examined for other species that use cavities. Less information is available on population levels of other users relative to densities of cavities and cavity trees. And management goals for nongame wildlife are more difficult to define. One goal of the National Forest Management Act is to ensure viable populations of all native wildlife. The abundance of cavities necessary to accomplish this goal for users of cavities that also use other structures, such as deer mice and raccoons, is unknown. Evans and Conner (1979) listed dependent bird species and calculated "maximum densities" by dividing 100 ha by the average territory size reported in the literature. They then determined the number of snags required to maintain percentages of maximum density. They assumed four snags were required per breeding pair per year and chose a multiplier of 10 snags to ensure the four would be available. Their recommendations translate to a density of 26 snags/ha for the woodpecker species that were present on Middle Mountain and Cheat Ranger District (downy, hairy, red-bellied, and pileated woodpeckers, northern flickers, and yellow-bellied sapsuckers). About 40 percent of the trees in both areas were dead, had part of their trunks dead, or had large dead branches. They provided a density of more than 200 snags/ha in the oak-hickory forest and more than 150 snags/ha in the maple-beech-birch forest--substantially more than the 26 snags/ha suggested by Evans and Conner (1979). Conner<sup>5</sup> suggested using a more stringent definition of snag: a tree that is dead or mostly dead. There were 33 dead trees/ha in the oak-hickory forest and 22-55

---

<sup>5</sup>Conner, R. N. 1983. Personal correspondence. USDA Forest Service, Southern Forest Experiment Station, Nacogdoches, Tex 75962.

dead trees/ha in the maple-beech-birch forest. These densities produced 1.4 recently excavated woodpecker cavity trees/ha in the oak-hickory forest and 0.8-1.1 woodpecker cavity trees/ha in the maple-beech-birch forest. The data suggests that the oak-hickory supported 54 percent of maximum populations and the maple-beech-birch 31-42 percent; both forests would therefore be rated "fair" on a scale of good, fair, and poor. These over-simplified calculations were performed to reemphasize points made by Conner and Adkisson (1977): it is difficult to determine when a tree is suitable for excavation by woodpeckers; and the extent of decay in a live tree is difficult to determine without dissecting the tree. It is evident that further research is necessary to relate the abundance of users of cavities to forest characteristics. Abundance and variability in abundance by forest characteristics and variability in abundance over a number of years must be known before one can confidently formulate management goals to ensure viable populations. The actual abundance of woodpeckers in the oak-hickory forest was 0.2 birds/ha in the spring in 1981; densities in the maple-beech-birch forest were much less in the spring of 1982 (Carey 1983). The oak-hickory density was 24 percent of maximum--a poor environment for nesting by the standards of Evans and Conner (1979).

#### Forest Ecology

It is important to view cavity trees and the species that use them not in isolation, but as elements of the forest community. It is also important to recognize that users of cavities are adapted to environments that existed in the past but which are now rare in the eastern hardwood forests. Reviewing what is known about forest development helps to place in the proper context the cavities in trees and the species that use them. Bormann and Likens (1979) provided a useful model of forest development consisting of four phases: reorganization, aggradation, transition, and steady state.

Reorganization begins with a regenerative disturbance and lasts for about 20 years in northern hardwood forests. Most kinds of disturbance occur as continua; for example, wind ranges from mild breezes to hurricanes. Competition, aging, insects, disease, climatic fluctuations, weather (drought, ice storms, early snow), and simple growth make trees more susceptible to the action of physical forces. Minor physical disturbance can make trees more susceptible to subsequent disturbance by breaking limbs, reducing leaf area, and increasing susceptibility to insects and disease. This weakens the tree's competitive position in the forest. At the low end of the disturbance continuum individual trees may fall resulting in a small patch of regeneration. At the other extreme, intensive winds or fires may result in large areas of regeneration.



Reorganization after disturbance is characterized by an increase in herbs, shrubs, and young trees; dead wood (dead limbs on live trees, standing dead trees, and fallen logs) is at a minimum 20 years after a disturbance (for example, clearcutting). Given the shelter and forage requirements of users of cavities, this phase provides the least hospitable environment.

Aggradation lasts from year 21 to year 170 and is characterized by the development of intermediate to large trees with a few massive trees present. Living biomass increases throughout aggradation, but the amount of dead wood peaks at 50-70 years. This phase provides a favorable environment for those species that can use small, dead trees with soft sapwood (for example, black-capped chickadees) or medium-sized trees with large dead branches and top rot (for example, hairy woodpeckers). Dead wood is as abundant at 56 years as at 170 years; but the amount of dead wood fluctuates between year 56 and year 170. In my studies it appeared that standing dead trees peaked between 50 and year 70 but then declined in abundance and contributed to the fallen dead wood biomass. Although the common wisdom is that the older a forest is, the better it is for wildlife that use cavities, my studies suggest that during aggradation in a managed forest environment an important part of the habitat requirements of some cavity-using wildlife may peak at 50 to 70 years, particularly in the maple-beech-birch forest. Post-regeneration management activities, such as thinnings, which are now being stimulated by demand for firewood (Carey and Gill 1980), may have significant impacts on cavity-using populations.

Towards the end of aggradation, cavity-users such as gray squirrels and pileated woodpeckers would find their optimal environment as characterized by intermediate, large, and massive trees, many of which would be senescent and have top rot. During transition (170-350 years) there is a loss of the old, even-aged dominants and a temporary increase in dead wood.

The steady state forest (older than 350 years) is a mosaic of three states: herb-shrub-young tree, small-intermediate-large tree, and massive tree. The steady state forest provides the optimal environment--the complete range of conditions to which the various species are adapted. The variety of environments in the steady state probably reduces interspecific competition by providing small, dead trees in some patches, large live trees with top rot in other patches, and large, dead trees in still other patches. Obviously the patches differ not only in type of trees containing cavities but also in overall structure and suitability for any particular species.

In forest managed for wood products, a different mosaic results. Two states predominate, the herb-shrub-young tree and the

small-intermediate-large tree. Forest development is truncated at mid-aggradation. This truncation has obvious impacts on cavity-users such as pileated woodpeckers. Because the pileated woodpecker can range widely, the steady state forest probably provides an optimal environment with scattered large trees (or patches of large trees) suitable for cavities and patches containing concentrations of foraging substrate (fallen trees or standing dead trees). Other users of cavities would find favorable environments in or among the individual patches. The present-day second-growth forests mimic, somewhat poorly, the steady state with scattered large trees carried over through regeneration, stands in early aggradation, and trees damaged by fires or introduced diseases. Interspecific competition is probably exaggerated in this environment, due to the greater homogeneity than is found in the steady state. For example, in present-day second-growth forests red squirrels or gray squirrels may compete more intensely with white-breasted nuthatches or black-capped chickadees than might occur in the steady state where cavities are abundant in a greater variety of environments. But the modern (future) intensively managed forest is characterized by complete clear-cutting, control of stocking, fire prevention, and short rotations, potentially depriving most cavity-users of amenable environments.

The historical record of the presettlement eastern deciduous forests is vague. Russell (1983) concluded that forest fires were not frequent in the northeastern United States. Bormann and Likens (1979) reported that destructive major storms were not major recycling factors, but that localized intensive winds associated with storm fronts were important. And small-scale windthrow of single trees to medium patches was (and is) common. Thus the scale of disturbance seems to have been small--occasional small fires and localized windthrow; large fires and major windthrow events were less common.

I have seen no discussion of the role of insects or disease in presettlement forests. Present day forests in Appalachia still show the effects of the chestnut blight: fallen dead trees and gaps filled by oaks, hickories, maples, beeches, or birches (Oosterhuis et al. 1982). The steady state forest, then, is a mosaic of small patches. The present trend of small management units (Roach (1974) recommended 8-12 ha as a silvicultural optimum), as compared to the extensive clearcuttings of the past, should be beneficial to users of cavities.

#### MANAGEMENT IMPLICATIONS

Cavities in trees constitute a diverse and complex resource just as the species that use them are diverse and respond to their environments in complex ways. Users of



cavities are valuable in several ways; for example, gray squirrels and raccoons are game animals; deer mice and cavity-using birds are insectivorous and help to control deleterious insect populations; rodents (including deer mice, flying squirrels, and gray squirrels) are essential for the dissemination of hypogeous ectomycorrhizal fungi that are essential to tree growth; cavity-using birds are important objects of study to birders, naturalists, and the general wildlife viewing public; the wildlife contributes to the aesthetic qualities of the forests; and many cavity-users (especially gray squirrels and woodpeckers) are essential for the creation and maintenance of cavities. But even with these many values it is difficult to formulate precise management objectives. On national forests, one objective and one management constraint are common. The objective is to maintain huntable populations of gray squirrels (or fox squirrels); the constraint is to ensure minimum viable populations of native wildlife. The results of this study, therefore, will be discussed in the light of the objective and the constraint.

#### Oak-Hickory Forest

##### Abundance of Trees With Cavities

Abundance of trees with cavities varied almost two-fold in environments that did not differ in species composition, age, mean d.b.h., density, or basal area. Therefore mean cavity tree abundance by age-class is insufficient information on which to base management. Variability in cavity tree abundance must be taken into account in determining areas of age classes to be managed for users of cavities. If only mean abundances are used, the chances that management objectives would not be met are great. Evaluation of habitat to choose stands with high abundances of trees with cavities could be used to reduce the area required to maintain viable populations of users and to increase the probability of meeting management objectives.

Because random events appear to play an important role in determining cavity tree abundance, stand characteristics such as age, d.b.h., and density, and topographical features such as slope position and aspect cannot be used to accurately predict cavity tree abundance. Careful evaluation of habitat and monitoring of the populations will be necessary for effective management.

It is difficult to evaluate the abundance of cavities per se without more information on the relationships among snags, trees having cavities, and the populations of users. The abundance of snags was more than adequate according to Evans and Conner (1979), but the abundance of woodpecker cavity trees and woodpeckers was well below their recommendations for fair to good populations. Conner (1979) suggested that it would not be prudent to base management on minimums and that

management should attempt to provide habitat quality close to, but slightly below, optimum levels. It would seem that Middle Mountain would be considered as marginally ensuring viable populations of cavity-using birds. But there is no way to tell if snags were too few to support higher numbers of birds, if bird populations were too low to use the snags available, or if the management recommendations are overly conservative. It may be that "snag" (defined as a dead or partly dead tree) is not a useful management concept, or that 40 snags per pair of woodpeckers is too low a ratio for the purposes of habitat evaluation and management. The abundance of gray squirrel cavity trees was more than adequate according to Sanderson's (1975) recommendations.

##### Formation of Cavities

A major proportion of trees with cavities had diameters that were greater than 75 percent of the trees more than 10-cm d.b.h.; a significant number of these trees seemed to have been carried over from the previous harvested stand. A rotation age of 85 years is considered to be the maximum age for "good" oak sawlog management; 95 years is fair; 115 years is poor (Trimble et al. 1974). With an 85-year rotation, it may be necessary to leave clumps of trees to ensure future supplies of large cavity trees. The clumps should contain live trees vigorous enough to survive a second rotation, or trees sufficiently large to have developed top rot or to be suitable for techniques that accelerate cavity formation. Sanderson (1975) and Zeedyk and Evans (1975) provided guidelines for retention of such trees. Not only would carried-over trees provide large cavity trees in the subsequent mature stand, they would also facilitate the formation of cavities in the subsequent stand by permitting populations of gray squirrels and woodpeckers to become established earlier than would otherwise be possible.

A significant proportion of cavity trees were also in suppressed small trees. Although non-commercial intermediate treatments are not justified economically (Webster and Meadows 1974) or silviculturally (Carvell 1971, Kirkham and Carvell 1980, Smith 1962, Trimble 1971), demand for firewood has made intermediate cutting practical, bringing timber management into conflict with providing habitat for wildlife (Carey and Gill 1980). Firewood sales (or increased future demand for pulpwood or small roundwood) not only provide revenues and products but also improve sawlog yields (Gingrich 1971). Thus, although killing small trees for stand improvement and to ensure a continuous supply of dead trees for foraging and excavating cavities (Evans 1978) seems reasonable, such direct habitat improvement may not be economically feasible. But, commercial intermediate cuttings may become more frequent than in the past.



Ensuring viable populations of some cavity-nesting wildlife in the future may result in more opportunity costs than occurred in the past. Because 82 percent of the area in forests managed on an 80-year rotation are 40-60 years old (Roach 1974), it is unlikely that firewood demand will be great enough to prompt intermediate cuttings in all these stands. Much of the area occupied by these stands will be too far from roads or in topographic positions too unattractive to attract firewood cutters. But only 14 percent of the forest area would be 60-80 years old, and the scarcity of the older age classes would be more limiting than the abundance of small, dead trees in unthinned young stands. Extending rotations or retaining clumps of mature trees during harvests will be costly.

#### Kinds of Cavities

A diverse array of cavities and a good mix of bird and mammal cavities were found on Middle Mountain. Conspicuously scarce were trees with pileated woodpecker nest cavities and trees with large cavities. The sites on Middle Mountain were all upland sites. I have observed greater abundances of trees with large cavities and pileated woodpecker cavities on lowland sites and riparian areas where trees do not seem as susceptible to windthrow as on ridges or mountain sides. While I did not study lowland sites in the studies reported herein, the reduction in forests on lowland sites (Zeedyk and Evans 1975) may cause serious problems in ensuring supplies of large cavities and trees suitable for cavity excavation by pileated woodpeckers. Trends in land use and the patterns of abundance of this resource need more study.

#### Maple-Beech-Birch Forest

Most of the management implications of abundance of trees with cavities and formation of cavities in trees for the oak-hickory forest also apply to the maple-beech-birch forest. In addition, small, dead trees seemed to be of greater importance in the maple-beech-birch forest than in the oak-hickory. Recommended rotations for sawlogs are shorter (60-70 years) than in the oak-hickory (Trimble et al. 1974). Because site index is substantially higher in the maple-beech-birch than in the oak-hickory, intermediate cuttings may be economically justifiable (Webster and Meadows 1974), and timber management guides recommend thinning to reduce the loss of wood products to decay (Trimble 1963, Leak et al. 1969). But Roach (1977) felt that there was insufficient evidence to justify thinning to promote growth.

A less diverse array of cavities was found in the maple-beech-birch forest than in the oak-hickory forest. And the proportion of these cavities used by birds was lower than in the oak-hickory forest. More specific management would have to be undertaken in the

maple-beech-birch forest to ensure a supply of bird-cavity trees than in the oak-hickory forest. In particular, killing medium to large trees may be appropriate. Further research on, or careful monitoring of, the supply of cavity trees and the abundance of cavity-using birds should be undertaken.

#### ACKNOWLEDGMENTS

I thank all those who assisted in the field: J. D. Gill, W. M. Healy, E. S. Nenno, and F. L. Pogge of the USDA Forest Service and R. Frame, D. Adamo, E. Leavitt, C. Boone, M. Gillespie, and S. Byrd of the Young Adult Conservation Corps. All worked long hours under arduous conditions and in winter weather. The personnel of the Monongahela National Forest Supervisor's Office, Cheat Ranger District, and White Sulphur Springs Ranger District assisted in study site selection. The West Virginia Department of Natural Resources assisted by providing logistical support and field quarters. The wildlife faculty of West Virginia University assisted in recruitment of field assistants, and D. Samuel provided computer time that allowed data analysis to proceed despite Federal budget cuts. I thank R. N. Conner, J. D. Gill, W. M. Healy, D. A. Manuwal, W. C. McComb, R. M. DeGraaf, and D. E. Samuel for reviewing an earlier version of this paper. The research reported here was conducted as part of the Northeastern Forest Experiment Station's Wildlife Habitat Management in the Central Appalachians Research Work Unit, formerly located at West Virginia University, Morgantown.

#### LITERATURE CITED

- Bormann, F. Herbert, and Gene E. Likens. 1979. Pattern and process in a forested ecosystem. 253 p. Springer-Verlag, New York, N.Y.
- Boyer, Roger L. 1976. Abundance of tree cavities for wildlife in a Michigan red maple floodplain forest. *The Jack-Pine Warbler* 54(4):155-158.
- Bull, Evelyn L., Asa D. Twombly, and Thomas M. Quigley. 1980. Perpetuating snags in managed mixed conifer forests of the Blue Mountains, Oregon. p. 325-336. *In* Workshop Proceedings: Management of western forests and grasslands for nongame birds. [Salt Lake City, Utah; February 11-14, 1980]. USDA Forest Service General Technical Report INT-86, 535 p. Intermountain Forest and Range Experiment Station, Ogden, Utah.
- Carey, Andrew B. 1983. Monitoring diurnal cavity-nesting bird populations. *In* Proceedings of the Snag Habitat Management Symposium. [Flagstaff, Ariz., June 7-9, 1983]. USDA Forest Service General Technical Report RM *in press*. Rocky Mountain Forest and Range Experiment Station, Ft. Collins, Colo.



- Carey, Andrew B., and John D. Gill. 1980. Firewood and wildlife. USDA Forest Service Research Note NE-299, 5 p. Northeastern Forest Experiment Station, Broomall, Pa.
- Carey, Andrew B., and William M. Healy. 1981. Cavities in trees around spring seeps in the maple-beech-birch forest type. USDA Forest Service Research Paper NE-480, 7 p. Northeastern Forest Experiment Station, Broomall, Pa.
- Carey, Andrew B., and H. Reed Sanderson. 1981. Routing to accelerate tree-cavity formation. *The Wildlife Society Bulletin* 9(1):14-21.
- Carvell, Kenneth L. 1971. Silvicultural aspects of intermediate cuttings. p. 60-64. *In* Oak Symposium Proceedings. [Morgantown, WV; August 16-20, 1971]. 161 p. USDA Forest Service, Northeastern Forest Experiment Station, Upper Darby, Pa.
- Conner, Richard N. 1978. Snag management for cavity nesting birds. p. 120-128. *In* Workshop Proceedings: Management of southern forests for nongame birds. [Atlanta, Ga.; January 24-26, 1978]. USDA Forest Service General Technical Report SE-14, 176 p. Southeastern Forest Experiment Station, Asheville, N.C.
- Conner, Richard N. 1979. Minimum standards and forest wildlife management. *The Wildlife Society Bulletin* 7(4):293-296.
- Conner, Richard N., and Curtis S. Adkisson. 1977. Principal component analysis of woodpecker nesting habitat. *The Wilson Bulletin* 89(1):122-129.
- Cottam, Grant, and J. T. Curtis. 1956. The use of distance measures in phytosociological sampling. *Ecology* 37(3):451-460.
- Dalke, Paul D. 1948. Some observations on den trees in the Missouri Ozarks. *Journal of Wildlife Management* 12(1):107-109.
- Dennis, John V. 1969. The yellow-shafted flicker (*Colaptes auratus*) on Nantucket Island, Mass. *Bird-Banding* 40:2930-3008.
- Dixon, W. J., chief editor. 1981. BMDP statistical software 1981. 726 p. University of California Press, Berkeley, Ca.
- Evans, Keith E. 1978. Oak-pine and oak-hickory forest bird communities and management options. p. 76-89. *In* Workshop Proceedings: Management of southern forests for nongame birds. [Atlanta, GA; January 24-26, 1978]. USDA Forest Service General Technical Report SE-14, 176 p. Southeastern Forest Experiment Station, Asheville, N.C.
- Evans, Keith E., and Richard N. Conner. 1979. Snag management. p. 214-225. *In* Workshop Proceedings: Management of North Central and Northeastern forests for nongame birds. [Minneapolis, Minn.; January 23-25, 1979]. USDA Forest Service General Technical Report NC-51, 268 p. North Central Forest Experiment Station, St. Paul, Minn.
- Frane, James. 1981. P9R: All possible subsets regression. p. 264-277. *In* Dixon, W. P., chief editor. BMDP statistical software 1981. 726 p. University of California Press, Berkeley, Ca.
- Gill, John D., Jack W. Thomas, William M. Healy, James C. Pack, and H. Reed Sanderson. 1975. Comparison of seven forest types for game in West Virginia. *Journal of Wildlife Management* 39(4):762-768.
- Gingrich, Samuel F. 1971. Stocking, growth, and yield of oak stands. p. 65-73. *In* Oak Symposium Proceedings. [Morgantown, WV; August 16-20, 1971]. 161 p. USDA Forest Service, Northeastern Forest Experiment Station, Upper Darby, Pa.
- Gysel, Leslie W. 1961. An ecological study of tree cavities and ground burrows in forest stands. *Journal of Wildlife Management* 25(1):12-20.
- Hardin, Kimberly I., and Keith E. Evans. 1977. Cavity nesting bird habitat in the oak-hickory forest...a review. USDA Forest Service General Technical Report NC-30, 23 p. North Central Forest Experiment Station, St. Paul, Minn.
- Helwig, Jane T., and Kathryn A. Council, editors. 1979. SAS user's guide, 1979 edition. 494 p. SAS Institute, Inc., Cary, N.C.
- Kirkham, Kenneth B., and Kenneth L. Carvell. 1980. Effect of improvement cuttings and thinnings on the understories of mixed oak and cove hardwood stands. *Agricultural and Forestry Experiment Station Bulletin* 673, 16 p. West Virginia University, Morgantown, W.V.
- Leak, W. D., D. S. Solomon, and S. M. Philip. 1969. A silvicultural guide for northern hardwoods in the northeast. USDA Forest Service Research Paper NE-143, 34 p. Northeastern Forest Experiment Station, Broomall, Pa.
- McComb, William C., and Robert E. Noble. 1981. Nest-box and natural-cavity use in three mid-south forest habitats. *Journal of Wildlife Management* 45(1):93-101.
- Miller, Eileen, and Donald R. Miller. 1980. Snag use by birds. p. 337-356. *In* Workshop Proceedings: Management of western forests and grasslands for nongame birds. [Salt Lake City, Utah; February 11-14, 1980]. USDA Forest Service General Technical Report INT-86, 535 p. Intermountain Forest and Range Experiment Station, Ogden, Utah.
- Miller, Eileen, Arthur D. Partridge, and Evelyn L. Bull. 1979. The relationship of primary cavity nesters and decay. *Transactions of the Northeast Section of The Wildlife Society* 36:60-68.
- Oosterhuis, L., R. A. A. Oldeman, and T. L. Sharik. 1982. Architectural approach to analysis of North American temperate deciduous forests. *Canadian Journal of Forest Research* 12(4):835-847.



- Roach, Benjamin A. 1974. Scheduling timber cutting for sustained yield of wood products and wildlife. USDA Forest Service General Technical Report NE-14, 13 p. Northeastern Forest Experiment Station, Broomall, Pa.
- Roach, Benjamin A. 1977. A stocking guide for Allegheny hardwoods and its use in controlling intermediate cuttings. USDA Forest Service Research Paper NE-373, 30 p. Northeastern Forest Experiment Station, Broomall, Pa.
- Russell, Emily W. B. 1983. Indian-set fires in the forests of the northeastern United States. *Ecology* 64(1):78-88.
- Sanderson, H. Reed. 1975. Den-tree management for gray squirrels. *The Wildlife Society Bulletin* 3(3):125-131.
- Scott, Virgil E., Jill A. Whelan, and Peggy L. Svoboda. 1980. Cavity-nesting birds and forest management. p. 311-324. In Workshop Proceedings: Management of western forests and grassland for nongame birds. [Salt Lake City, Utah; February 11-14, 1980]. USDA Forest Service General Technical Report INT-86, 535 p. Intermountain Forest and Range Experiment Station, Ogden, Utah.
- Smith, David M. 1962. The practice of silviculture, seventh edition. 578 p. John Wiley & Sons, New York, N.Y.
- Trimble, George R., Jr. 1963. Cull development under all-aged management of hardwood stands. USDA Forest Service Research Paper NE-10, 10 p. Northeastern Forest Experiment Station, Broomall, Pa.
- Trimble, George R., Jr. 1971. Some hardwood culls do not need treatment...and these can be identified. *Northern Logger and Timber Processor*: 12, 32, 33.
- Trimble, George R., Jr., James H. Patric, John D. Gill, George H. Moeller, and James N. Kochenderfer. 1974. Some options for managing forest land in the central Appalachians. USDA Forest Service General Technical Report NE-12, 42 p. Northeastern Forest Experiment Station, Broomall, Pa.
- Webster, Henry H., and John C. Meadows, Jr. 1974. Economic evaluation of intermediate operations in oak stands. p. 74-83. In Oak Symposium Proceedings. [Morgantown, WV; August 16-20, 1971]. 161 p. USDA Forest Service, Northeastern Forest Experiment Station, Upper Darby, Pa.
- Weigl, Peter D. 1978. Resource overlap, interspecific interactions and the distribution of the flying squirrels, Glaucomys volans and G. sabrinus. *American Midland Naturalist* 100(1):83-96.
- Zeedyk, William D., and Keith E. Evans. 1975. Silvicultural options and habitat values in deciduous forests. P. 115-127. In Symposium Proceedings: Management of forest and range habitats for nongame birds. [Tucson, AZ; May 6-9, 1975]. USDA Forest Service General Technical Report WO-1, 543 p. U.S. Department of Agriculture, Forest Service, Washington, D.C.



# A Device for Viewing and Filming the Contents of Tree Cavities<sup>1</sup>

Dan W. Speake<sup>2</sup> and James A. Altieri<sup>3</sup>

---

Abstract.--A miniature television camera system was tested for inspecting and video tape recording the contents of tree cavities and other animal dens. The camera is enclosed in a stainless steel cylinder 32 mm in diameter and 340 mm long and is connected to a flexible cable 38 m long. A lighted viewing accessory that has a fixed right-angle mirror is especially valuable for tree cavity work. The image is produced on a small television monitor component of the remote control camera unit, which is powered by a portable generator.

---

## INTRODUCTION

It is well known that cavities in trees provide nesting and den sites for a wide variety of vertebrates, especially hole-nesting birds (Bull et al. 1980, Conner et al. 1975, Cunningham et al. 1980, Dennis 1971, Gysel 1961, Pinkowski 1976, Scott et al. 1977). Techniques used in the past to examine cavities include climbing the tree or snag and using flashlights and mirrors (Bellrose 1964, Gysel 1961, Seidensticker and Kilham 1968). Although these techniques are useful, each has limitations or dangers (Snyder and Rossol 1958). Improved methods for viewing the interior of tree cavities would have practical value for survey and research.

We recently acquired a "Miniature Underwater TV Camera for Nuclear Reactor Inspection ETV-1250," from Westinghouse Electric Corporation<sup>4</sup> After a field demonstration by Westinghouse representatives, we determined immediately the utility of the camera for our current research needs, which required a method of inspecting the burrows of gopher tortoises (*Gopherus polyphemus*). After we had gained more experience and further tested the camera and accessory equipment, it became evident that the camera system would be useful for examining other relatively inaccessible places such as tree cavities.

We thank Larry Healy of Westinghouse Corporation for his invaluable technical guidance and

---

<sup>1</sup>Paper presented at the Snag Habitat Management Symposium (Flagstaff, Arizona, June 7-9, 1983).

<sup>2</sup>Dan W. Speake is Unit Leader at Alabama Cooperative Wildlife Research Unit, Auburn University, Ala.

<sup>3</sup>James A. Altieri is a wildlife technician at Alabama Cooperative Wildlife Research Unit, Auburn University, Ala.

<sup>4</sup>Reference to commercial products does not imply Government endorsement.

Terry Harper of the Auburn University Educational Television Department for advice and assistance with technical problems and the editing of video tape.

## MATERIALS AND METHODS

The closed circuit TV camera system consists of two units: a camera head and a camera control unit connected with a 38-m flexible multilead underwater cable 14.5 mm in diameter (fig. 1). Several accessories are available for the camera head that permit axial and right-angle viewing, with or without an intergral light source. The camera head has a diameter of 32 mm and an overall length of 340 mm. One end of the camera housing is permanently attached and factory-molded to the cable. Threaded into the other end of the housing is the optical viewing port assembly, containing a quartz window. Both camera lighting and focusing are remotely operated from the camera control unit, which also has a 10.2-cm diagonal TV monitor. An external video outlet allows the use of a larger external TV monitor as well as a video tape recorder. The camera can operate at temperatures of -25° to 60° C. The special "Newvicon" tube provides increased light sensitivity, yielding a clear picture with low light intensity (0.015 foot-candle face plate illumination). For tree cavities, a lighted fixed right-angle lens is especially valuable because only the camera head needs be inserted into the cavity entrance. Little movement is required to view the entire cavity and its contents. A new lighted right-angle "fish eye lens" is being developed by Westinghouse that should facilitate the viewing of large cavities.

For field work a portable power supply is necessary. We have successfully used a portable electric generator that supplies 1,500 watts ac voltage, which is more than adequate to operate the camera and accessory equipment. Cavity contents are filmed with a Magnavox<sup>4</sup> television video recorder that records on half-inch video tape. The use of an integrated switchbox enables instant review of recorded material in the field.



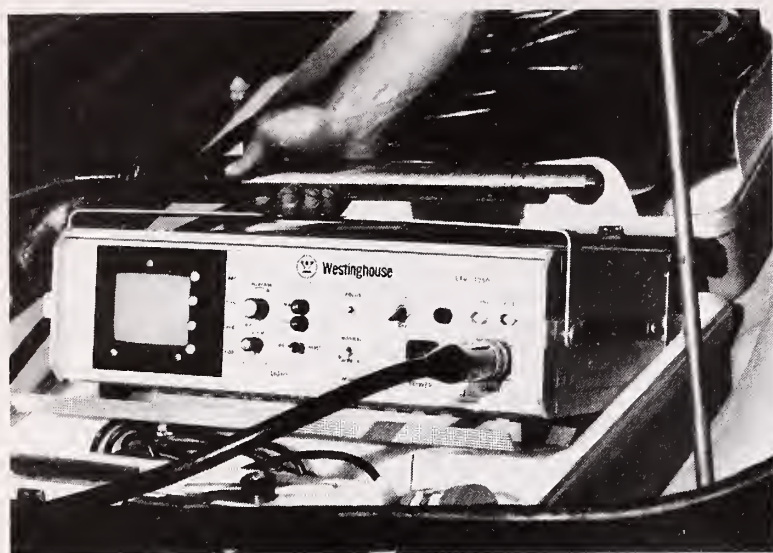

Figure 1.--Westinghouse Miniature Television Camera ETV-1250 control unit and camera with right angle-viewing attachment.

Camera and cable, control unit, generator and video equipment together weight 72.6 kg. The equipment can be transported with a four-wheel-drive vehicle, or (where that is not possible) with three-wheel all-terrain vehicles equipped with trailers.

We have used a light aluminum telescoping pole extendable to 4.3 m. The camera head is attached, with the cable hanging free. Cavities higher than 4.9 m have been approached with a light ladder. The ladder used in conjunction with the telescoping pole permits looking into cavities about 9 m above ground level. Methods for using the camera at heights considerably greater than 9 m are under investigation.

#### RESULTS AND DISCUSSION

We have examined numerous tortoise burrows and some 60 tree cavities (Table 1).

Using a lighted axial viewing "fish eye lens", we were able to clearly distinguish all occupants

of deep burrows with average diameters of about 30.5 cm. The camera can be focused on items as small as individual scales on snakes or small insects. A panoramic view of the burrow can also be obtained.

We tested camera resolution in the laboratory by attempting to distinguish both a coin (nickel) and small bird eggs at different cavity depths. By using the internal lighting system provided with the right-angle viewing attachment and inserting the camera head just inside the cavity opening, we could clearly distinguish these objects at distances up to 61 cm. With additional light, this distance could be extended much further. When the right-angle, "fish eye lens" becomes available, it may be possible, with adequate light, to view much larger hollows. Another especially valuable feature of the TV camera system is its capability for video-taping.

The two main limitations of the camera system now available are lighting for very large or deep cavities and the difficulty of reaching high cavities with minimum risk. It should be possible to reduce or remove both restrictions by further research and development.

#### LITERATURE CITED

- Bellrose, F.C., K.L. Johnson, and T.U. Meyers. 1964. Relative value of natural cavities and nesting houses for wood ducks. *J. Wildl. Manage.* 28(4):661-676.
- Bull, E.L., A.D. Twombly, and T.M. Quigley. 1980. Perpetuating snags in managed mixed conifer forests of the blue mountains, Oregon. *Proc. Workshop. Management of Western Forests and Grasslands for Nongame Birds.* USDA For. Ser. Gen. Tech. Rep. INT-86:323-336.
- Conner, R.N., R.G. Hooper, H.S. Crawford, and H.S. Mosby. 1975. Woodpecker nesting habitat in cut and uncut woodlands in Virginia. *J. Wildl. Manage.* 39(1):144-150.
- Cunningham, J.B., R.P. Balda, and W.S. Gaud. 1980. Selection and use of snags by secondary cavity-nesting birds of the ponderosa pine forest. *USDA For. Ser. Research Paper R-M-222*, 15 pp.

Table 1. Results of tree cavity<sup>1</sup> survey in which a miniature television camera was used as a viewing device.

Measurements (cm) of cavities					
	DBH of trees (cm)	Height	Entrance diameter	Depth <sup>2</sup>	Percentage of cavities active <sup>3</sup>
$\bar{X}$	40	485	8.6	27.2	30
Ranges	(14 to 76)	(10 to 1219)	(4 to 51)	(0 to 76)	

<sup>1</sup>Includes 53 natural cavities in both live and dead trees and 7 bird boxes; all measurements are averages.

<sup>2</sup>Excludes hollow trees.

<sup>3</sup>Cavities occupied or with evidence, such as feathers or nesting material, of previous use.

- Dennis, J.V. 1971. Species using red-cockaded woodpecker holes in northeastern South Carolina. *Bird-Banding* 42(2):79-87.
- Gypsel, L.W. 1961. An ecological study of tree cavities and ground burrows in forest stands. *J. Wildl. Manage.* 25(1):12-20.
- Pinkowski, B.C. 1976. Use of tree cavities by nesting eastern bluebirds. *J. Wildl. Manage.* 40(3):556-563.
- Scott, V.E., K.E. Evans, D.R. Patton, and C.P. Stone. 1977. Cavity-nesting birds of North American forests. USDA For. Ser. Agric. Hand. 511. 112 pp.
- Seidensticker, J.C., and L. Kilham. 1939. A device for examining nesting cavities. *Bird-Banding*. 39:228-230.
- Snyder, E.B., and H. Rossoll. 1958. Climbing southern pines safely. USDA For. Ser. South. For. Exp. St. Occas. Pap. 159.



# Monitoring Diurnal, Cavity-Using Bird Populations<sup>1</sup>

ANDREW B. CAREY<sup>2</sup>

---

Abstract.--Monitoring cavity-using bird populations will be necessary to ultimately determine if habitat (snag) management is meeting the objectives set for management indicator species and helping to meet the major constraint of ensuring viable populations of all indigenous species of wildlife.

Recent advances in line-transect sampling theory, methodology, and data analysis suggested that not much additional effort is required to obtain a density estimate than is required to obtain a questionable index. Thus, to determine the applicability of line-transect sampling using measured distances to birds and Fourier series analysis of the decline in detectability, I developed a sampling protocol and surveyed diurnal, cavity-using bird populations in oak-hickory forests (98 km) and in beech-birch-maple forests (27 km) in West Virginia. Density estimates were obtained for two groups of species, primary and secondary cavity-users, in the oak-hickory forest. Coefficients of variation were reasonable for the groups, 12% and 14% respectively, and marginal for the estimates of density of most of the species (17-27%). Violations, and possible violations, of the assumptions were noted and are discussed; violations had more effect on the precision of the estimates than on the estimates themselves.

---

## INTRODUCTION

My purpose in this paper is to address some limited aspects of the monitoring requirements now being addressed by the National Forest System (Salwasser et al. 1983). In particular, I deal with monitoring populations of cavity-using birds in upland deciduous forests in Appalachia. First, I reiterate the definition of monitoring. Then I discuss what should be monitored and formulation of objectives for cavity-using birds. Because of past reviews of sampling methods (Brewer 1978, Robbins 1978, Shields 1979), a recent symposium

addressing all aspects of estimating the numbers of terrestrial birds (Ralph and Scott 1981), and a clear, concise treatise of sampling design and statistical methods for biologists (Green 1979) I do not provide an extensive review of the literature. Rather I simply discuss the rationale I used in selecting the sampling and analytical methods to be used in my pilot study. Then I present an evaluation of the applicability of line-transect sampling using measured, perpendicular, horizontal distances and Fourier series analysis to measuring cavity-using bird populations. Finally, I make recommendations for monitoring.

---

<sup>1</sup>Paper presented at the Snag Habitat Management Symposium, Northern Arizona University, Flagstaff, 7-9 June 1983.

<sup>2</sup>When the work reported herein was done, Carey was research biologist, Northeastern Forest Experiment Station, USDA Forest Service, Morgantown, W.Va. Now, he is research coordinator, Old-Growth Forest Wildlife Habitats Program, USDA Forest Service, Olympia, Wash. 98502

## Monitoring

Salwasser et al. (1983) defined monitoring as the "...collection and interpretation of population or habitat data, or both, to evaluate progress toward meeting objectives ...and indicate needed adjustments in... management...". They concluded that statistically reliable monitoring of populations (and

habitats) of wildlife and fish is a critical process in natural resources management.

### Monitoring Requirements

The USDA Forest Service (1982:43048) requires that fish and wildlife habitat on National Forests be managed to maintain viable populations of native and desired non-native species, that management indicator species be chosen and their habitats be maintained or improved, and that population trends of management indicator species be monitored. In these requirements I perceive two different monitoring needs--one to monitor population trends, suggesting species- or group-specific indexes and the other to determine if population levels (densities and patterns of abundance) are sufficient to ensure that populations will persist through time. Undoubtedly, it can be assumed that without drastic changes in forest management practices or land use patterns the abundance of some species may obviate the need for monitoring. But other species seem more sensitive to the effects of management and current land use patterns. A group of species with these kinds of sensitivities is the cavity-using birds. Although our knowledge of cavity-using bird-habitat relationships is far from complete, there seems to be ample evidence for concern about maintaining viable populations of these species under intensive forest management, hence this symposium.

### Objectives For Cavity-Using Birds

Determining what constitutes a minimum viable population is not an easy task. But Shaffer (1981) proposed a definition: "a minimum viable population for a given species in any given habitat is the smallest isolated population having a 99% chance of remaining extant for 1000 years despite the foreseeable effects of demographic, environmental, and genetic stochasticity, and natural catastrophe". Conner (1979) suggested that minimum standards for threatened and endangered species should be to provide habitat as close as possible to the optimum for the species. And that for other species, management to provide habitats between the mean optimum environment and one standard deviation below this mean should suffice. Evans and Conner (1979) suggested levels of abundance of snags and densities of woodpeckers that could correspond to a variety of objectives for cavity-using birds in northeastern deciduous forests. Thus it seems that objectives formulation has gone as is reasonable with our current knowledge and that it is now appropriate for monitoring to start "feeding back" information about objectives.

### A SAMPLING PILOT STUDY

I began research on cavity-using wildlife in Appalachia in 1979. It was readily apparent that there was a lack of quantitative information on some fundamental aspects of the ecology of cavity-using wildlife. Little was known about the patterns of abundance of snags (dead or partly dead trees) and trees containing cavities. Likewise the relationships between snag and cavity-tree abundance and the abundance of cavity-using birds had not been quantified. And the numerical relationship between the primary cavity-excavators and secondary cavity-users had not been described. The natural variability of these abundances and relationships within and among biotopes was also unknown. All these items are key information for effective management. Therefore I initiated studies of the patterns of abundance of cavity-trees (Carey and Healy 1981, Carey 1983). But it was apparent that sampling techniques for quantifying the abundance of cavity-using birds were just being developed. Therefore I began pilot studies to determine if population densities could be precisely estimated.

### Choosing A Technique

I decided that sampling techniques that provide relative abundance (indexes to actual abundance) would be inadequate for quantifying the relationships I was interested in and for subsequent monitoring for several reasons. First, indexes (numbers per unit effort, such as birds/time spent listening, birds/distance walked, birds/area searched) are not very useful unless calibrated by actual density estimates and therefore lack the basic qualities required for making inferences about many parameters (White et al. 1982). Second, indexes do not permit comparisons among species (for example, species A is more abundant than species B). And within species comparisons may be substantially biased by differences just in detectability of species in differently structured environments or by different observers (Shields 1979, Ralph and Scott 1981). Indexes, when rigidly standardized (sampling must be conducted in the same season, time of day, weather, and habitat), can be used to qualitatively monitor local population changes of a single species from year to year. Conner and Dickson (1980) suggested that relative abundances derived from strip transects could be used to evaluate the effects of silvicultural (or other) treatments on birds communities. It seems to me that if sufficient effort is expended to adequately sample bird populations to obtain reliable indexes, the additional effort required to model the decline in detectability of the birds from the transect line in order to estimate densities would not be great compared to the gain in the reliability and comprehensiveness of the



information and in the confidence that could be placed in the results. In addition, I feel that there are many often unstated or unexamined assumptions required for indexes that are unwarranted. For example, the assumption that the relationship between the index and the actual density does not change with density or with species composition of the community being sampled may not be warranted. Finally, I feel that there is a tendency among biologists to be less careful when collecting data for indexes than when collecting data for density estimates because they are "just after an index, not density".

All methods for estimating bird abundance require assumptions and incorporate some bias, inaccuracy, and imprecision. Therefore, in deciding on a method to use, I considered criteria such as applicability for sampling large or numerous areas and criteria that assumptions should be minimal, that standardization of the procedures to reduce bias should be practical, and that analytical procedures should be robust to violations of assumptions. I rejected the spot (territory) mapping technique because it is not easily applied to sampling large areas (Robbins 1978). Variable circular plots, line-transects, and other types of transect methods are appropriate for extensive sampling (Scott et al. 1981). I decided not to use the variable circular plot methods (Reynolds et al. 1980) because it seemed to me that too much effort would be expended in getting from plot to plot in roadless areas at the expense of collecting data. And because I would be sampling when trees were leafless and visibility would be good, the major advantage of the method--that of detecting birds in dense forests where visibility is low--was not important. Some informal field testing indicated that fewer cavity-using birds were seen per effort expended using variable circular plots. And many of the birds were first detected when their movement into the area caught the eye of the observer. Movement into the area being sampled violates major assumptions of any analytical method used to calculate density estimates from variable circular plot data. Line-transects attempt to reduce the effects of bird movement by having observers move at a rate that is fast relative to the movement of the birds. Therefore I decided to use a transect method.

Two categories of transect methods, strip-transects and line-transects, are applicable to estimating bird densities. Strip-transects entail recording all birds detected (seen and/or heard) out to a prescribed distance from the transect line whereas line-transects do not have boundaries (Eberhardt 1978). In the simplest case, when one can assume that all the birds present in a strip were detected, density estimates are straightforward; Amman and Baldwin (1960) estimated woodpecker densities in coniferous forests with

this approach. However, in most situations one cannot assume all the birds present were detected and prescribing a narrow strip results in small sample sizes and in ignoring detectable birds. Detectability usually declines with increasing distance from the transect line. The decline in detectability must then be modeled before density estimates can be made. Emlen (1971, 1977) and Jarvinen and Vaisanen (1975, 1976) proposed approaches to modeling the decline in detectability that have been widely accepted. Dickson (1979) used a variation of Emlen's (1971) method to estimate cavity-using bird densities in Louisiana. However, these approaches rely on unwarranted assumptions and are subject to a variety of biases and errors (Shields 1979). Unwarranted assumptions include assumptions about the shape of the detectability function and the assumption that predetermined strip widths are optimal for all species. Biases arise from differences among observers in ability to estimate distances ocularly and aurally. In order to overcome some of the inherent biases and arbitrariness in transect methods, Burnham et al. (1980) suggested using line-transects with a nonparametric approach (Fourier series analysis) to modeling the decline in detectability. The perpendicular distance from the transect line to each bird detected is recorded. Careless or inaccurate measurements and rounding errors can lead to poor estimates of density and sampling variances, therefore distances should be measured, not ocularly or aurally estimated (Anderson et al. 1979). The perpendicular distance can also be calculated from the sighting distance and sighting angle if the bird is observed forward of the observer and the distance and angle are measured. Measuring the sighting angle and distance ensures a perpendicular distance even if the observer can no longer see the bird when he moves up the line. However, errors in sighting angle and distance are compounded in the calculated perpendicular distance. In addition, I feel that perpendicular distances must also be horizontal distances to obtain accurate density estimates. In rugged topography it is often hard to measure horizontal distances directly. Therefore the angle of departure from the horizontal should be measured and used to correct non-horizontal perpendicular distances.

There are many factors in addition to measurement errors which contribute bias and cause errors in transect-derived density estimates (Anderson et al. 1979, Shields 1979). Factors which affect an observer's ability to detect birds include the speed at which the line is walked, the observer's physical ability (to hear, to see, to avoid fatigue), topography, weather, and the structure of the forest vegetation. Interspecific differences (size, coloration, and behavior), intraspecific differences (particularly those due to age and gender), seasonal-, diel-, and weather-related behavioral changes, and



responses to competitors and predators determine the conspicuousness of the birds. The effects of these factors can be ameliorated through standardization of procedures, training sessions for observers, confining the sampling to a short time period within a biologically defined season, confining the sampling to morning hours, not sampling on windy or rainy days, and use of robust statistical analyses. Thus, I decided to use line-transect sampling with measured angles and distances and to record birds as within or outside of a 25-m boundary so that the Finnish line-transect method (Jarvinen and Vaisanen 1975) could be used should too few measured perpendicular distances be obtained.

### Study Areas

My initial study area was in the oak-hickory forest on Middle Mountain in Greenbrier and Pocahontas Counties, West Virginia. Later, study areas were chosen from maple-beech-birch stands in Randolph and Tucker Counties, West Virginia. Both study areas were described elsewhere in this symposium (Carey 1983). Gill et al. (1975) established 57 parallel transects across Middle Mountain. They randomly located the initial transect and established subsequent transects at 0.4-km intervals from the initial transect. The beginning of each transect was randomly located within 40 m of the southeastern Forest Service boundary. Permanent metal markers were placed every 80.5 m along each transect until the northwestern boundary was reached. I used the center four transects (numbered 26-29). I placed transects along the long axis of one 206 years old, two 100 years old, and three 65 years old maple-beech-birch stands.

### Sampling Procedures

Three experienced biologists (J. D. Gill, W. M. Healy, and me), interested in the study and familiar with the local avifauna, were the observers. Each biologist had detailed, written instructions (modified from Anderson et al. 1979 and Shields 1979), a hand-held compass for measuring angles, a short-distance (2 to 30 m) optical rangefinder, a long-distance (15 to 180 m) optical rangefinder, binoculars, pencils, and data forms. The instructions were designed to reduce observer variability and specified (1) start shortly after sunrise, (2) walk at an average speed of 1 km/hour (4 min. between transect-line stakes), (3) scan from side-to-side but pay particular attention to the areas nearest the line to avoid missing birds on the line (a major assumption of line-transect analysis is that all birds on the line were detected), (4) record the average of at least 2 measurements for each variable (sighting angle, sighting distance, perpendicular distance, angle of departure from the horizontal), and

(5) if a bird cannot be seen, record it as  $\leq 25$  m or  $> 25$  m from the line. The angle of departure of the line of sight from the horizontal was included to allow the perpendicular distance to be corrected to horizontal perpendicular distance when a horizontal perpendicular distance could not be directly measured (e.g., a bird in a tree top, or below in a lower topographical position).

In addition, each biologist was instructed to record any observations that indicated violation of the assumptions of line-transect sampling. Specifically, records of bird moving at first detection, birds fleeing or being attracted to the observers, birds evading, moving in front of or along with the observers, and problems in distance measurement were to be made. These observations were discussed and summarized each day.

Two 1-km transect lines with targets at measured distances (24 targets, 1.3 to 57.0 m from the line) were used to train the biologists in procedures and to increase their proficiency with the rangefinders.

Each of the four Middle Mountain transects (26 to 29) was subdivided into three consecutive (end to end) 1-km lines separated by 40 to 120 m (fig. 1). Each set of three lines were separated by 0.4 km. Thus, total transect length was 12 km. The lines were well marked with flagging and paint, and the permanent stakes were renumbered. The transects were perpendicular to the main ridge of Middle Mountain; thus the lines were along elevational gradients. None of the lines was on a trail or along another discontinuity such as a stream. Similar procedures were followed in establishing the maple-beech-birch transects, except lines were generally along contours. Transect lengths were 0.8-2.0 km.

Bird surveys were conducted in winter (8 to 13 December 1980) in the oak-hickory and in spring in the oak-hickory (1 to 9 April 1981) and in the maple-beech-birch (26 April-2 May 1982). Winter is a long period of relatively constant bird behavior and good visibility (deciduous trees are leafless) and thus offered the potential for long sampling periods. Spring samples were taken during the breeding season of cavity-nesting birds, a time when the birds are most conspicuous and most stationary. Because cavity-nesting birds breed earlier (February-April) than most other birds, the trees were still leafless and visibility was good.

In the winter survey each biologist was assigned one set of three 1-km lines by random drawing. The rate of traverse (1 km/hour) proved to be too fast for winter conditions in the rugged topography. Thus, only two 1-km lines were surveyed each day (at 0.5 km/hour) by each biologist; 36 km were surveyed. Because



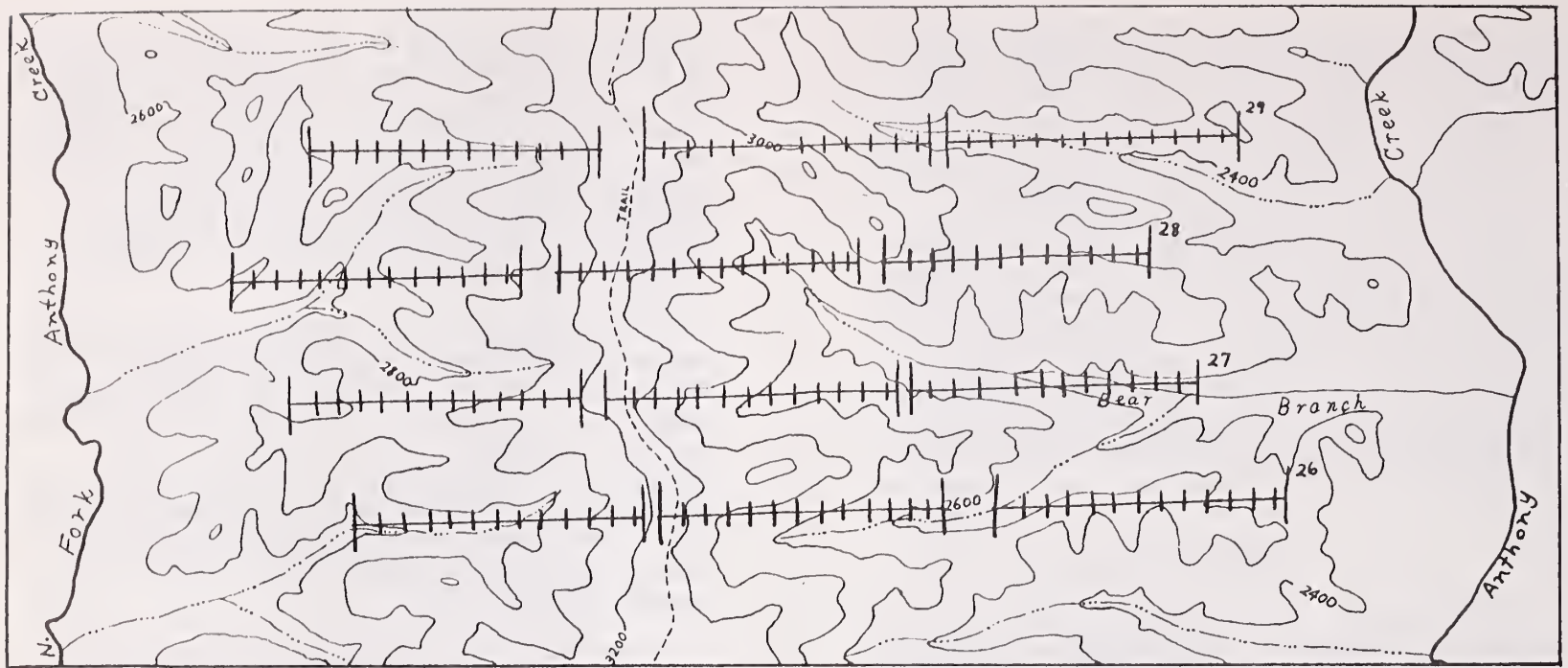

Figure 1. Middle Mountain line transects; each transect is 1-km with stations at 80.3 m.

surveying the same lines day after day proved to be too boring to allow proper concentration, a rotating sequence using all four transects was used in the spring, with the starting transects randomly assigned. A speed of 1 km/hour and a sample of three 1-km lines per biologist per day proved possible in the spring; 62 km were surveyed.

#### Analytical Procedures

The computer program TRANSECT (Laake et al. 1979) and the Fourier series analysis were used to analyze the measured distances data. This method is pooling robust (Burnham et al. 1980:45), not sensitive to differences among observers, biotopes, and species. Thus, the observations recorded by the biologists were pooled for two groups, cavity-excavating species and secondary (non-excavating) cavity-users. When the number of distances measured was large, species population densities were also estimated.

The data consisting of all cavity-using birds seen or heard were analyzed for a 20-m fixed width strip (10 m on either side of the line), a 50-m fixed width strip (25 m on either side of the line), and the improved Finnish method (Jarvinen and Vaisanen 1975) with birds recorded as within or more than 25 m from the line. Fixed width strip analyses assumed that all birds in the strip were seen or heard. The improved Finnish method of analysis assumed a linear decline in detectability with one parameter estimated. That parameter was  $k$ , the species specific constant for detectability, where  $k = (1 - \sqrt{1-p})/W$ .  $W$  was 25 m and  $p$  was estimated by dividing the number of birds detected within 25 m by the total number detected. The equation

used to calculate density was: density (birds per  $\text{km}^2$ ) =  $1000N K/T$ , where  $N$  is the total number of birds detected, and  $T$  is the number of kilometers of transect surveyed.

#### Results

##### Winter Survey

It was not possible to obtain density estimates from the winter survey data. Of 232 cavity-using birds recorded (seen or heard) during 36 km of surveys, 126 (54%) were in 28 feeding flocks (Table 1). Most of these flocks were moving rapidly and it was not possible to obtain accurate counts of flock members. Nor was it feasible to determine the flock center. Thus, the flock data were not suitable for density estimation (Burnham et al. 1980:31). The median perpendicular distance at which the leading edges of the flocks were detected was 11.0 m. The average species composition of flocks was 2.67 black-capped chickadees (*Parus atricapillus*), 1.86 golden-crowned kinglets (*Regulus satrapa*), 1.29 white-breasted nuthatches (*Sitta carolinensis*), 0.25 tufted titmice (*P. bicolor*), 0.25 red-breasted nuthatches (*S. canadensis*), 0.21 brown creepers (*Certhia familiaris*), 0.21 downy woodpeckers (*Picoides pubescens*), and 0.18 hairy woodpeckers (*P. villosus*). Perpendicular distances were measured to 34 stationary birds that were not in flocks (Table 1); 56 other birds were heard but could not be precisely located; 16 were seen while they were moving. Some birds flew in to investigate the observers; others fled at the approach of the observers. Birds could be detected from great distances. (For example, pileated woodpeckers (*Dryocopus pileatus*) were heard at distances of 320 to

Table 1. Number of cavity-using birds recorded and detection distances measured during a winter survey of 36 km of line transects on Middle Mountain in West Virginia in 1980.

Species	Total	In a flock	Not in a flock			
			<25m	>25m	Median distances	
					N	M
Pileated woodpecker	23	0	0	17(6) <sup>1</sup>	6	71
Hairy woodpecker	40	5	23(11)	12(4)	15	19
Downy woodpecker	22	6	12(7)	4(2)	9	9
White-breasted nuthatch	54	36	9(4)	9(0)	4	8
Red-breasted nuthatch	7	7	0(0)	0(0)	0	-
Tufted titmouse	7	7	0(0)	0(0)	0	-
Black-capped chickadee	79	75	0(0)	4(0)	0	-
Total	232	136	44(22)	46(12)	34	19

<sup>1</sup>Total number detected, including those to which distance was only estimated as within or beyond 25 m, and in parentheses number to which distance was measured; birds moving before they were detected are not included.

1,000 m and hairy woodpeckers were heard at distances of >240 m (distance estimates are based on actual sighting or on stationary birds near the transect lines that could be heard well forward of the observer). Despite general differences between calls and drumming among species of Picoides woodpeckers, it was not possible to identify some individuals positively from calls or drums. In addition, species in flocks shared a "feeding" call.

#### Spring Survey, Oak-Hickory Forest

Breeding activity, as evidenced by singing, drumming, chasing, courting, defending territories, mating, and excavating cavities, was underway during the spring survey. However, some black-capped chickadees were in small feeding flocks with golden-crowned kinglets, and some downy woodpeckers were foraging near white-breasted nuthatches. Birds were often conspicuous at great distances, but some, such as hairy woodpeckers, were easily alarmed and would hide or give alarm calls at the approach of an observer. Pileated woodpeckers and common flickers (Colaptes auratus) seemed particularly evasive; both species were observed moving ahead of observers. Stationary pileated woodpeckers were hard to locate because they would stay near the base of a tree or move to the ground to give alarm calls.

More cavity-users were recorded in the spring (N = 388) than in the winter (N = 232); in part because the number of kilometers walked was greater in the spring (62 km versus 36 km). Also yellow-bellied sapsuckers were present in the spring but not in the winter. Likewise, more distances were measured in the spring (N = 144) than in the winter (N = 34), (Tables 1 and 2). Although common flickers and a red-bellied woodpecker (Melanerpes carolinus) were present on the study area, none were detected before or at flight on the lines and no distances to these species were measured. Densities estimates were made using ungrouped distances (Table 3) and distances grouped into 10-m intervals extending laterally from the lines (Table 4). Program TRANSECT indicated that 10 m was the optimum grouping interval. Grouping (Table 5) reduced the coefficients of variation (CV) substantially, probably because there was "heaping" in the data (Burnham et al. 1980:48). Heaping refers to clustering of distance values as opposed to a continuous distribution of values. The CV's for the density of primary (12.4%) and secondary cavity-users (13.9%) were reasonable but those for individual species were somewhat high (16.6 to 27.4%). Lowering the CV to 10% would have required surveying 120 km for secondary, and 107 km for primary, cavity-users. A CV of 20% could have been obtained by surveying 30 km for secondary, and 24 km for primary cavity-users. Thus one observer would require



Table 2. Numbers of cavity-using birds recorded and detection distances measured during a spring survey of 62 km of line-transects on Middle Mountain in West Virginia in 1981.

Species	Total	Detection distance			
		<25 m	>25 m	Median	
				N	M
Pileated woodpecker	61	4(3) <sup>1</sup>	57(2)	5	22
Red-bellied woodpecker	6	0(0)	6(0)	0	25
Common flicker	3	1(0)	2(0)	0	25
Hairy woodpecker	37	20(16)	17(6)	22	13
Downy woodpecker	38	16(14)	22(7)	21	13
Yellow-bellied sapsucker	30	26(24)	4(4)	28	10
White-breasted nuthatch	69	18(16)	51(1) <sup>2</sup>	17	11
Red-breasted nuthatch	2	2(2)	0(0)	2	0
Tufted titmouse	28	3(3)	25(0)	3	7
Black-capped chickadee	114	73(44)	41(2)	46	7
Total	388	163(122)	225(22)	150	9

<sup>1</sup>Total number detected, including those to which distance was only estimated as within or beyond 25 m, and in parentheses number to which distance was measured.

<sup>2</sup>White-breasted nuthatches were vociferous and their calls often were heard at distances from which the birds could not be seen.

Table 3. Densities of cavity-using birds calculated from ungrouped perpendicular distances from transect lines by using Fourier Series analysis; data from spring 1981, 62-km survey on Middle Mountain in West Virginia.

Statistic	Cavity-using birds	
	Primary <sup>1</sup>	Secondary <sup>2</sup>
Perpendicular distance		
N	76	68
x	17.29	10.42
SE	1.60	0.98
Density per hectare		
N	0.249	0.335
SE	0.048	0.047
CV, %	19.1	14.2
CI, 95%	0.155-0.342	0.242-0.428

<sup>1</sup>Includes pileated, hairy, and downy woodpeckers, and yellow-bellied sapsuckers.

<sup>2</sup>Includes black-capped chickadees, white-breasted nuthatches, red-breasted nuthatches, and tufted titmice.

Table 4. Densities of cavity-using birds calculated from perpendicular distance frequencies grouped in 10-m intervals laterally from transect line by Fourier series analysis; data from the spring 1981, 62-km survey on Middle Mountain in West Virginia.

Species	N	N/ha	SE	CI, 95%	CV, %
Primary cavity-users <sup>1</sup>	76	0.196	0.024	0.149-0.244	12.4
Hairy woodpecker	22	0.054	0.013	0.028-0.079	24.2
Downy woodpecker	21	0.055	0.015	0.025-0.084	27.4
Yellow-bellied sapsucker	28	0.086	0.017	0.052-0.121	20.6
Secondary cavity-users <sup>2</sup>	68	0.406	0.056	0.295-0.517	13.9
Black-capped chickadee	46	0.265	0.044	0.179-0.351	16.6

<sup>1</sup>Includes pileated, hairy, and downy woodpeckers and yellow-bellied sapsuckers.

<sup>2</sup>Includes black-capped chickadees, white-breasted nuthatches, red-breasted nuthatches, and tufted titmice.

Table 5. Frequencies of distance measurements by 10-m intervals; data are from the spring 1981, 62-km survey on Middle Mountain in West Virginia.

Species	Perpendicular distance in meters					
	0-10	11-20	21-30	31-40	41-50	51-60
Primary cavity-users	32	17	13	8	4	2
Hairy woodpeckers	8	7	3	1	2	1
Downy woodpeckers	9	3	3	5	1	
Yellow-bellied sapsuckers	14	5	6	2	1	
Secondary cavity-user	42	22	2	1	1	
Black-capped chickadee	29	14	2	1		

8 to 10 good weather days (surveying 3 km/day) to obtain point estimates with CV of 20%.

#### Spring Survey, Maple-beech-birch Forest

A total of 21.6 km were surveyed; 6 km in the 206 years old stand, 6.5 km in 100 years old stands, and 9.1 km in 65 years old stands. Only 25 distance measurements were made. Similarly, few birds were heard. As the rate of observations was 1.1 measurements/km and was one-half the rate recorded in the oak-hickory it was apparent that we would not obtain a sufficient sample size in the time that had been allotted for sampling; therefore sampling was discontinued. The weather during sampling was warm and partly cloudy to clear.

#### Discussion

##### Sampling Assumptions

The reliability of density estimates by line-transect rests on five assumptions (Burnham et al. 1980:14):

Birds Directly On The Line Are Never Missed:--I believe this assumption was met. Concentrating searching on the line and the leafless trees made it unlikely that birds on the line were missed. It is important to note that this assumption applies to the line itself, not to the entire sampling area surrounding the line. It is not required, nor is it likely, that all the birds near the line are detected.

Birds Do Not Move Before Being Detected:--Movement by birds does not have a detrimental effect unless the movement is in response to the observer and before the bird is detected. This assumption was violated in at least a small proportion of the potential occurrences. Pileated woodpeckers and common flickers actively evaded the observers by moving from or along the line. However, a more typical response was an alarm call or evasive behavior without substantial distance movement; for example, moving around a tree. Birds often did flee when the observer came near, but then they were most often detected at or before flight.

No Bird Is Counted More Than Once:--The potential for an individual observer to count the same bird more than once was low, except for pileated woodpeckers and common flickers.



However, when the observers were simultaneously traversing parallel transects on Middle Mountain, the potential for double counting increased, even with the transects 0.4 km apart. On at least one occasion, pileated woodpeckers fleeing one observer landed near another observer 0.4 km away.

No Measurement Or Rounding Errors Occur:--  
This assumption was violated. Although rangefinders were calibrated daily and the observers were experienced, measurement errors probably occurred. Jiggling or bumping the rangefinders could change this calibration. It could also be affected by trying to measure distances outside the range of the rangefinders. Lighting conditions affected the observers' ability to make measurements. Hand-held compasses are crude devices for measuring sighting angles and angles of departure from the horizontal. Heaping was noted in the data, suggesting rounding errors. I assumed that there was no systematic bias, only random error, in the distance measurements. Comparison of detectability histograms of perpendicular distances corrected to horizontal perpendicular distances with histograms of uncorrected perpendicular distances revealed that if distances had not been corrected there would have been a tendency for more birds to be recorded at intermediate distances than close to the line. Thus, failure to record horizontal distances would have resulted in overestimates of bird densities.

Sightings Are Independent Events:--Lack of independence does not affect the point estimates of density but does affect the estimates of variance. This assumption was violated when birds were in flocks or pairs. Thus, the greatest bias was in the variance of black-capped chickadee density. In addition, stopping to locate a visually inconspicuous bird often resulted in additional birds being detected.

#### Methodology

The violations of assumptions were not as severe as can be expected when distances are visually estimated or when aural cues are used to estimate distances. In future studies, biases could be further minimized by strictly adhering to sampling protocols (e.g., keeping pauses brief), wearing camouflage clothing (safety colors were worn early in this study), not using aluminum (reflective) clipboards, using clinometers to measure the angle of departure from the horizontal, and taking extreme care in using the rangefinders.

Rate of traverse is an important variable that needs to be optimized, but it is hard to standardize. There are tradeoffs among detecting birds, avoiding the bias of bird movement (i.e., the rate of traverse should be fast relative to the movement of the birds), sampling sufficient areas, and remaining inconspicuous to the birds. Speed must be

adapted to the difficulty of traverse and is necessarily slow when birds are present and measurements must be made. It was the consensus of the biologists in the study that subjective judgement is necessary. An analogy with still-hunting can be made--walking at a careful, slow rate (adapted to footing and terrain) with numerous brief pauses and, once a target is detected, assuming a stalking mode until all measurements are ensured. Such a speed would be variable, ranging between 0.5 km/hour and 2.0 km/hour in rugged terrain and averaging 1.0 km/hour.

#### Accuracy and Precision

There is no way to judge the accuracy of the density estimates because the actual densities were unknown. But the line-transect/Fourier series analysis can be compared to other methods. Total cavity-using bird density calculated from all birds seen or heard within 10 m of the transect line was (assuming all present were detected) 0.597 birds/ha. Density calculated by the improved Finnish method was 0.604 birds/ha. These estimates are strikingly close to those derived by Fourier series analysis (0.602/ha). But density estimated from all birds seen or heard within 25 m of the line (assuming all present were detected) was 0.526 bird/ha and 13% lower than the other estimates, indicating detectability had declined significantly.

Likewise it is hard to evaluate the precision of the estimates as many authors fail to report actual sample sizes, let alone variance estimates. But Tilghman and Rusch (1981) did report coefficients of variation of line-transect density estimates calculated by 12 methods of analysis (but not Fourier series analyses). Distances were aurally or visually estimated and evidently not corrected to horizontal distances. Coefficients of variation for black-capped chickadees for 11 of the 12 CV's for black-capped chickadee density were greater than 35%; one was 19.1%. The CV for black-capped chickadee density on Middle Mountain was 16.6%. Average (over 12 methods) CV's for nine species were 32.6-56.1%; on Middle Mountain, CV's were 16.6-27.4%. Scott et al. (1981) reported that 10% error in distance estimation would result in 20% error in density estimates. I would expect that my CV's would have been lower yet if a more homogeneous environment had been sampled; 35 stands were intersected by the transects which encompassed two major aspects and 300 m elevation. In addition, some variability had to be introduced by multiple observers and measurement error, especially in angles, that could have been reduced by using clinometers or better rangefinders.



## Density Estimates

There are few reliable estimates of cavity-user abundance in northeastern hardwood forests. I believe the ones reported here are more reliable than most. Evans and Conner (1979) used percentages of maximum densities of woodpeckers to set management goals: 80 to 100% for "good", 40 to 60% for "fair", and 20% of the maximum for "poor" environments. Maximum densities were calculated from territory sizes. Using their criteria, Middle Mountain would be rated a poor environment for hairy and downy woodpeckers (11% and 22% of maximum densities) and an excellent environment for yellow-bellied sapsuckers (172% of the maximum density). The yellow-bellied sapsucker was the only migratory species for which distances were measured; it may be that some of the sapsuckers observed were still migrating. Combining maximum densities for the woodpecker species included in my density estimates indicated a poor environment overall (24% of maximum). My subjective evaluation of Middle Mountain, based on other studies (Carey and Healy 1981; Carey, 1983), is that it is at least a fair, and probably a good environment for cavity-using birds. The stands on Middle Mountain had not been subjected to intensive management (e.g., thinnings or improvement cuttings) but had been damaged by ice storms; 50% of the trees had evidence of butt- or top-rot and 10% had one or more large (>8 cm) dead branches. The stand ages and condition of the trees suggest that the potential for cavity-formation was high (Carey and Sanderson 1981). Snag densities were much higher than recommended by Evans and Conner (1979) but the abundance of woodpecker cavity-trees was well below their recommendations for fair-good populations (Carey 1983).

The maple-beech-birch forest had even lower abundances of birds and woodpecker cavity-trees. I spent a considerable amount of time over a three-year period in the study areas (Carey and Healy 1981, Carey 1983) and I and my co-workers were quite struck by the paucity of cavity-using birds compared to the oak-hickory forest. As I previously noted (Carey 1983) there was a distinct lack of stands older than 60-70 years in our two-county study area.

## RECOMMENDATIONS FOR MONITORING

Management indicator species such as pileated woodpeckers are not easily studied by the techniques I presented here. Therefore I will confine my recommendations to the more general aspects of sampling cavity-using bird communities composed of hairy woodpeckers, downy woodpeckers, yellow-bellied sapsuckers, and the secondary cavity-using birds. I do this because my knowledge and experience in sampling bird populations rests with the latter, not because I wish to down play the former. The

pileated woodpecker plays a major role in the formation of cavities for most-cavity-using wildlife (Carey 1983) and its ecological requirements are such that it probably is more sensitive, in the short-term, to intensive timber management than the other cavity-using birds.

The time is approaching when increased harvest of trees in eastern deciduous forests may be stimulated by the maturing of second- and third-growth stands, demand for wood as fuel (Carey and Gill 1980), attempts to create new markets through forest products research and research on harvesting methods, and the projected wood shortage that always seems to loom just over the horizon. Future harvests will not leave the residual trees (cull trees and undesirable timber species) that were left in the past and that ameliorated the effects of past harvests on cavity-using wildlife (Carey 1983). And intermediate cuttings have become economically feasible, and thus more frequent (Carey and Gill 1980). The changes that could occur in cavity-using bird populations and community composition because of changes in the proportions of the stages of forest development could be considerable (Kendeigh 1982). If the decision is made by forest planners to monitor cavity-using bird populations because of concern over the impact of intensive timber management on the environment's capability to maintain viable populations of cavity-dependent species, biologists may be hard-pressed to respond if baseline data are lacking. There have been few long-term baseline studies. Kendeigh (1982) conducted such a study. His principal finding was that "avifauna is in continual flux correlated with time and space...populations fluctuate in yearly cycles, from year to year, and less conspicuously over decades and longer intervals...variations occur intra-regionally in species composition and population sizes... changes in community structure accompany these fluctuations and variations." Factors contributing to fluctuations were numerous and included changes in vegetation (proportions in various stages of forest development) that influenced interspecific competition for territories, food, and nesting sites and thereby greatly influenced populations levels attained by cavity-using birds including the various species of woodpeckers, tufted titmice, and white-breasted nuthatches. Thus I recommend instituting baseline monitoring studies, not only to document the patterns of fluctuations in cavity-using bird abundance, but also to quantify the relationships among cavity-tree abundance, forest structure, abundances of cavity-excavators, and abundances of secondary cavity-users. As Kendeigh (1982) pointed out, species may vary locally in biotope requirements depending on the vegetation, interspecific competition, and prevailing climate.



If the decision is made to monitor cavity-using bird populations, several aspects of experimental design will be of importance because population monitoring is time consuming and expensive. Stratification by age class (or silvicultural treatment) and forest type will be necessary; I found considerable differences in abundance and types of cavities between the oak-hickory and maple-beech-birch forests. Within strata, stands to be sampled should be chosen randomly so that the results may be extrapolated to the planning unit; "grabbing a handful is not the same as random sampling" (Cochran et al. 1954). Controls would be desirable but difficult to choose; every stand changes with time and mature stands developed under management would surely be different from "natural" or unmanaged stands. Disease and insect attacks on trees can greatly influence the avifauna. In the absence of catastrophic events, wilderness or other reserved areas could serve some functions of control areas. Green (1979) provide a good review of sampling design.

Because of the dynamic nature of the forest environment, and because of the great variability in similarly treated stands (Carey 1983) I recommend that monitoring be in terms of population densities, not relative abundances. I recommend variable circular plots for small stands where one or two 1-km transect lines cannot be surveyed and line-transects for larger stands. With both procedures, I recommend recording both measured, horizontal, perpendicular distances and aural estimates. Measured distances can be used to determine the relationship between rigorous sampling techniques and less-demanding techniques in environments of various structure and composition. If good correspondence is found between, say, line-transects with measured distances and Fourier series analysis and improved Finnish line transects, then the only distances that would have to be measured would be those near 25 m. Measured distances, Fourier series analysis, and the improved Finnish method can be easily applied to variable circular plots. I recommend avoiding techniques that rely on visual and aural estimation of distances over a wide range of distances, for example, the variable width line-transects. I recommend double sampling and consideration of non-measured distances not because I found distance measurement cumbersome and time consuming (I didn't), but because if the relationship between techniques is well demonstrated, then aural cues could be used and would result in greater sample sizes and thus possibly would permit more stands to be sampled. If the decision is made to monitor all diurnal, forest bird populations, the distance measurements could not only become time consuming and cumbersome but also impractical because sampling would have to be delayed until the general breeding season when trees are in full leaf. However, I recommend that specific groups of

target species be chosen for monitoring so that observers can concentrate searching for them without being faced with having to detect, recognize, and estimate distances to all birds.

Finally, it is important to recognize that survey procedures and analytical methods will be improved. But in the interim, I recommend the guidelines proposed by Anderson et al. (1979), Shields (1979), and herein for sampling methodology and the critical examinations of assumptions and biases presented by Burnham et al (1980) and especially by the various authors in Ralph and Scott (1981).

#### ACKNOWLEDGEMENTS

I thank Bill Healy and John Gill for participating in the sampling and for reviewing an early version of this paper. Dave Capen, Susan Doehlert, Hew Crawford, and David Anderson also graciously reviewed the earlier version; I thank them too.

#### LITERATURE CITED

- Amman, G. D., and P. H. Baldwin. 1960. A comparison of methods for censusing woodpeckers in spruce-fir forest of Colorado. *Ecology* 41(4):699-706.
- Anderson, David R., Jeffrey L. Laake, Bradford R. Crain, and Kenneth P. Burnham. 1979. Guidelines for line transect sampling of biological populations. *The Journal of Wildlife Management* 43(1):70-78.
- Brewer, Richard. 1978. A comparison of three methods of estimating winter bird populations. *Bird-Banding* 49(3):252-261.
- Burnham, Kenneth P., David R. Anderson, and Jeffrey L. Laake. 1980. Estimation of density from line transect sampling of biological populations. *Wildlife Monographs* No. 72, 202 p.
- Carey, Andrew B. 1983. Cavities in hardwood forests. *In Proceedings of the snag habitat management symposium*. [Flagstaff, Ariz., June 7-9, 1983]. USDA Forest Service General Technical Report RM. *In press*. Rocky Mountain Forest and Range Experiment Station, Ft. Collins, Colo.
- Carey, Andrew B., and William M. Healy. 1981. Cavities in trees around spring seeps in the maple-beech-birch forest type. USDA Forest Service Research Paper NE-480, 7 p. Northeastern Forest Experiment Station, Broomall, Pa.
- Carey, Andrew B., and John D. Gill. 1980. Firewood and wildlife. USDA Forest Service Research Note NE-299, 5 p. Northeastern Forest Experiment Station, Broomall, Pa.
- Carey, Andrew B., and H. Reed Sanderson. 1981. Routing to accelerate tree-cavity formation. *The Wildlife Society Bulletin* 9(1):14-21.



- Cochran, William G., Frederick Mosteller, and John W. Tukey, 1954. Principles of sampling. *Journal of the American Statistical Association* 49:13-35.
- Conner, Richard N. 1979. minimum standards and forest wildlife management. *The Wildlife Society Bulletin* 7(4):293-296.
- Conner, Richard N., and James G. Dickson. 1980. Strip transect sampling and analysis for avian habitat studies. *The Wildlife Society Bulletin* 8(1):4-10.
- Dickson, James G. 1979. Seasonal populations of insectivorous birds in a mature bottomland hardwood forest in south Louisiana. p. 261-268. *In* *The role of insectivorous birds in forest ecosystems*, 381 p. Academic Press, New York.
- Eberhardt, L. L. 1978. Transect methods for population studies. *The Journal of Wildlife Management* 42(1):1-31.
- Emlen, John T. 1971. Population densities of birds derived from transect counts. *Auk* 88:323-342.
- Emlen, John T. 1977. Estimating breeding season bird densities from transects counts. *Auk* 94:455-468.
- Evans, Keith E., and Richard N. Conner. 1979. Snag management. p. 214-225. *In* *Workshop proceedings: Management of north central and northeastern forests for nongame birds*. [Minneapolis, Minn., January 23-25, 1979]. USDA Forest Service General Technical Report NC-51, 268 p. North Central Forest Experiment Station, St. Paul, Minn.
- Gill, John D., Jack W. Thomas, William M. Healy, James C. Pack, and H. Reed Sanderson. 1975. Comparison of seven forest types for game in West Virginia. *The Journal of Wildlife Management* 39(4):762-768.
- Green, Roger H. 1979. Sampling design and statistical methods for environmental biologists, 257 p. John Wiley and Sons, New York, N.Y.
- Jarvinen, Olli, and Risto A. Vaisanen. 1975. Estimating relative densities of breeding birds by the line transect method. *Oikos* 26(3):316-322.
- Jarvinen, Olli, and Risto A. Vaisanen. 1976. Finnish line transect censuses. *Ornis Fennica* 53:115-118.
- Kendeigh, S. Charles. 1982. Bird populations in east central Illinois: fluctuations, variations, and development over a half-century. *Illinois Biological Monographs* 52, 136 p. University of Illinois Press, Urbana.
- Laake, Jeffrey L., Kenneth P. Burnham, and David R. Anderson. 1979. User's manual for program TRANSECT, 26 p. Utah State University Press, Logan.
- Ralph, C. John, and J. Michael Scott, editors. 1981. Estimating numbers of terrestrial birds. *Studies in Avian Biology* No. 6, 630 p. Cooper Ornithological society, Allen Press, Inc., Lawrence, Kansas.
- Reynolds, R. T., J. M. Scott, and R. A. Nussbaum. 1980. A variable circular-plot method for estimating bird numbers. *Condor* 82:309-313.
- Robbins, Chandler S. 1978. Census techniques for forest birds. p. 142-163. *In* *Proceedings of the workshop management of southern forests for nongame birds*. [Atlanta, Georgia; January 24-26, 1978]. USDA Forest Service General Technical Report SE-14, 175 p. Southeastern Forest Experiment Station, Asheville, N.C.
- Salwasser, Hal, Carole K. Hamilton, William B. Krohn, James F. Lipscomb, and Carl H. Thomas. 1983. Monitoring wildlife and fish: mandates and their implications. *Transactions of the North American Wildlife and Natural Resources Conference* 48:*in press*.
- Scott, J. Michael, James D. Jacobi, and Fred L. Ramsey. 1981. Avian surveys of large geographical areas: a systematic approach. *The Wildlife Society Bulletin* 9(3):190-200.
- Scott, J. Michael, Fred L. Ramsey, and Cameron B. Kepler. 1981. Distance estimation as a variable in estimating bird numbers from vocalization. *Studies in Avian Biology* 6:334-340.
- Shaffer, Mark L. 1981. Minimum population sizes for species conservation. *Bioscience* 31(2):131-134.
- Shields, William M. 1979. Avian census techniques: an analytical review. p. 23-51. *In* *The role of insectivorous birds in forest ecosystems*, 381 p. Academic Press, New York.
- Tilghman, Nancy G., and Donald H. Rusch. 1981. Comparison of line-transect methods for estimating breeding bird densities in deciduous woodlots. *Studies in Avian Biology* 6:202-208.
- U.S. Department of Agriculture, Forest Service. 1982. National Forest System land and resource management planning. *Federal Register* 47(190): 43026-43052.
- White, Gary C., David R. Anderson, Kenneth P. Burnham, and David L. Otis. 1982. Capture-recapture and removal methods for sampling closed populations. *Los Alamos National Laboratory Report LA-8787-NERP*, 235 p. Los Alamos National Laboratory, Los Alamos, N.M.



# A Simple Model to Predict Snag Levels in Managed Forests<sup>1</sup>

Norm Cimon<sup>2</sup>

---

**Abstract.**--The need for quantitative estimates of snag levels is discussed. A simple model to predict snag levels in managed forests is developed. Projections of standing snags in two diameter classes for a typical managed stand are developed. The model, once verified, may prove its usefulness when incorporated within existing stand simulations.

---

## INTRODUCTION

### Snags as Habitat

Snags are an essential component of the habitat requirement for many species of wildlife. In the Blue Mountains of Oregon, for example, it is known that upwards of 60 different birds and mammals are cavity users (Thomas 1979).

### Current Snag Research

The importance of snags leads quite naturally to a series of questions: What type of snags are important? How many snags per acre, and of what species and diameter class, does it take to meet the specific requirements of a given species of bird or mammal? What role does forest succession play? Does the stage of decay of the snag have a significant impact on potential cavity users? I am certain that the reader could add many more to the list.

In fact, questions like these are the source of much of the active research in the field of snag management (Balda 1976, Conner 1973, Mannan 1977, McClelland 1975, Scott 1978). Many of these questions either have been or are in the process of being answered. To return to the case of the Blue Mountains,

Thomas (1979) detailed the specific requirements, by diameter and tree species, for each of the cavity using birds and mammals.

### Need for a Predictive Model

It starts to become evident that what is needed is a model that would project snag levels over time for all relevant species and diameter classes. With such a model, and the species specific requirements mentioned above, the wildlife manager would have the tools at hand to protect required levels of wildlife by protecting the needed snag habitat.

The rudiments of such a model were originally described in a paper by Bull et al. (1980). In this paper, I have extended the 1980 model by developing separate equations for each diameter class, and by including provisions for the growth of live trees from one diameter class to the next. This model explicitly attempts to predict the number of snags available, for a given tree species per acre by diameter class, over a series of planning intervals.

## METHODS

### Requirements for the Model

In this simplified model, prediction involves knowledge of certain basic information at each stage of the planning process. First of all a planning interval must be selected. For the purposes of the example given below, the interval chosen was 10 years. This is to say that the model will be updated in 10 year increments.

---

<sup>1</sup>Paper presented at the Snag Habitat Management Symposium, Flagstaff, Arizona, 7-9 June 1983.

<sup>2</sup>Norm Cimon, 1207 Y Avenue, La Grande, Oreg.

Once a planning interval is in hand, this determines the the magnitude of the various rates which are used in the equations for the model. Here is a list of these rates:

$P_d$  = the probability that a snag in diameter class  $d$  will remain standing over 1 time interval (this is 1-Fall Rate)

$M_d$  = the probability that a live tree in diameter class  $d$  will die over 1 time interval

$Q_d$  = the probability that a live tree in diameter class  $d$  will move to diameter class  $d+1$  in 1 time interval

$R_d$  = the probability that a tree in diameter class  $d$  will remain in diameter class  $d$  over 1 time interval

As is obvious, there is a heavy emphasis placed on a diameter structure for the model. There are reasons for this. First, it is a fact that there are definite preferences among certain species of woodpecker, for example, for snags that are of a certain minimum diameter (Thomas 1979). Wildlife management for such species thus requires insight into the diameter composition of the available snag habitat.

Second, existing studies (Keen 1955, Dahms 1949, VanSickle 1978, Lyon 1977, Bull in publication) have shown that, in general, snag fall rates follow a nonlinear pattern by diameter class. This is to say that we cannot expect a snag in the 10-20" class to stay up half as long on the average as a snag in the 20-30" class. The reality is that trees that are about twice as big across stay up more than twice as long.

In the same fashion, transition rates for live trees from one diameter class to the next are nonlinear (i.e. big trees have less diameter increment than small trees over the same time interval). So one equation for all of the diameter classes will not do. That is why we empahsize the diameter structure.

## Defining the Equations

### The Snag Equation

The snag equation is quite simple to state. To determine the number of snags in a given diameter class at the start of a planning interval, we start with the number of snags that remain standing from the start of the last planning interval. To this we add the number of live trees that were in that diameter class during the previous interval which we would expect to die off. So the snag pool is made up of recruits from the living population and

veterans from the snag population. In mathematical terms, the equation is:

$$S_d(n+1) = S_d(n) \times P_d + T_d(n) \times M_d$$

$P_d$  and  $M_d$  are as described previously, while  $S_d(n)$  and  $T_d(n)$  represent, respectively, the number of snags and the number of live trees in diameter class  $d$  at the start of time interval  $n$ .

Suppose we know that at time 0 we have, for the 10-20" diameter class which we will arbitrarily call class 2, a certain number of snags and live trees of that diameter class ( $S_2(0)$  and  $T_2(0)$ ). We would like to project the number of snags in this class 10 years, or 1 time interval, into the future. Then:

$$S_2(1) = S_2(0) \times P_2 + T_2(0) \times M_2$$

If we now assume that we have a way of obtaining the number of live trees that will be available at the start of time interval 1 for that diameter class we may then project 20 years into the future by calculating:

$$S_2(2) = S_2(1) \times P_2 + T_2(1) \times M_2$$

Thus, recursive calculations can be used to estimate the number of snags in each diameter class for successive time intervals.

### The Live Tree Equation

Somewhat more tenuously, we may write down a simple equation to project live tree growth over time so that we might continue to update the snag equation described above. This equation starts with the number of live trees in a given diameter class which are available at the beginning of a time interval and which might be expected to remain in that diameter class over the interval ( $T_d(n) \times R_d$ ). To this is added the number of trees from the immediately preceding diameter class which would grow into this diameter class during the time interval ( $T_{d-1}(n) \times Q_{d-1}$ ). The equation is:

$$T_d(n+1) = T_d(n) \times R_d + T_{d-1}(n) \times Q_{d-1}$$

At this point, we should pause to examine more closely the equations stated above. There are certain implicit assumptions which limit their usefulness. This is especially true for the second, or live tree, equation. This is not as crucial as it might first appear, however, since there exist far superior models to predict tree growth. One such model, the Stand Prognosis Model (Stage 1982), will be discussed below. Access to such a model would preclude the need to make use of the live tree equation, since mortality figures could be obtained directly from this more comprehensive modelling process.



The real value of this live tree equation may be in its ability to mimic the much more complicated processes of models like the Stand Prognosis Model (SPM). In situations where there is a specific management regime imposed on a stand, the live tree equation seems to hold very closely to the growth estimates of the stand prognosis model. The relationship between the live tree equation given above and models like the SPM could be the subject of future research.

#### Assumptions

At this point we would do well to list the assumptions we have made in developing the above system of equations. Specifically, we have assumed that the rate factors are constants, independent of stand density or distribution. While this may have validity for the snag retention rates (P) (this may be less applicable where the stand has been opened up and windthrow becomes a factor), it would seem to have less merit for calculating mortality (M).

A potentially more serious problem arises with the so called transition rates, Q and R. Stocking density will have a definite impact on these rates. In the SPM, for example, diameter growth for a specific tree is made functionally dependent upon the total basal area/acre of all trees greater in diameter than the target tree. In other words, for a given diameter class, Q and R are not constant but are density dependent parameters.

While these limiting assumptions might seem to limit usefulness of the live tree equation, in fact, this is not the case. Let us consider managed stands, for example.

#### Example

In managed stands, periodic thinnings insure that individual trees have enough growing space to minimize competition. We might then expect the transition factors, Q and R, to be more nearly constant. When the live tree equation was fitted to the SPM predicted values for a managed stand,<sup>3</sup> and the resulting rate factors used in the live tree equation, the results were quite close to the SPM predicted values (table 1).

Values for S, M, R and Q for both diameter classes were obtained using regression techniques with data from the SPM model. With these estimators, the model equations could be updated as a system. The resulting values for

<sup>3</sup>Obtained from the Wallowa Valley Ranger District of the Wallowa-Whitman National Forest, Joseph, Oregon.

Table 1.--Comparison of predicted number of live trees by diameter class over a 100 year period for the SPM and live tree equations (LTE).

Year	Predicted no. of trees by diameter class SPM/LTE	
	10"-20"	>20"
70	29 / 29	0 / 0
80	23 / 23	4 / 4
90	18 / 16	6 / 8
100	11 / 10	11 / 11
110	5 / 7	15 / 14
120	2 / 4	16 / 14
130	0 / 3	17 / 15
140	0 / 2	16 / 16
150	0 / 1	14 / 15
160	0 / 1	13 / 15

snag levels (per acre) for the 10"-20" and >20" classes are outlined in table 2.

The transition rates (Q and R) were obtained from a fit of data for the SPM predicted live tree numbers of table 1. Mortality for the live trees (M) was a by-product of this fit and, along with snag retention rates (P), was used to continuously update the snag equation to produce table 2.

To summarize, if the user has access to reliable estimates of stand distribution by diameter class over time, or better yet actual mortality figures by diameter class over time, then these, when combined with snag fall rates and a set of initial stand conditions, allow for an estimate of snag distribution, by diameter class over time.

In lieu of actual mortality figures in our example, we estimated the mortality rates, snag retention rates and transition rates, based on outputs from the SPM and produced the simulated live tree and snag numbers from the equations presented here.

#### DISCUSSION

Any model such as this one must be subject to intense scrutiny. As a first step, it is in need of field validation, as opposed to validation based on another model, such as the

Table 2.--Snag numbers over a 100 year period for two diameter classes.

Year	Number of snags by diameter class	
	10"-20"	>20"
70	0.0	0.0
80	2.6	0.0
90	3.3	0.1
100	2.9	0.3
110	2.2	0.5
120	1.5	0.6
130	1.0	0.8
140	0.7	0.9
150	0.4	1.0
160	0.3	1.1

SPM. This is especially true of the snag levels, since the SPM does not project these figures at all. In fact one of the recommendations that I would like to make is that models such as the Stand Prognosis Model have incorporated into them a simple equation to project snag levels. But first there must be validation.

In addition, data collection efforts should center on the determination of snag retention rates. These are of the utmost importance to accurate predictions of snag levels. This determination should be made for all tree species and diameter classes which are of importance to wildlife managers as potential habitat. At the very least, a literature search should be conducted to obtain all of those studies for which these rates might be computed.

A useful source of future determination of snag retention rates might be the existing forest inventory stands managed by the U.S. Forest Service. These inventories in the Blue Mountains track the number of downed snags. But there is no tagging, by diameter class or otherwise, and thus no possibility of determining over what period a specific snag may have fallen. If the inventory process could be modified to incorporate this knowledge then a large step would have been taken in gathering accurate data for the prediction of snag levels.

I am convinced that with this important bit of information a simple model like the one described above would allow for reasonable

estimates of the number of snags available over time, by species and diameter class. This would provide a starting point for maintenance of viable amounts of habitat for the many cavity users.

#### LITERATURE CITED

- Balda, Russell P., and James B. Cunningham. 1976. Snag selection and use by secondary cavity nesters of the ponderosa pine forest. Report submitted to the U.S. Forest Service. 103 p.
- Bull, Evelyn L., Asa D. Twombly, and Thomas M. Quigley. 1980. Perpetuating snags in managed mixed conifer forests of the Blue Mountains, Oregon. p. 325-336. In Management of western forests and grasslands for nongame birds. Workshop Proceedings. USDA Forest Service General Technical Report INT-86. Intermountain Forest and Range Experiment Station, Ogden, Utah.
- Bull, Evelyn L. In press. Longevity of snags and their use by woodpeckers. In Snag Habitat Management Symposium.
- Conner, R. N. 1973. Woodpecker utilization of cut and uncut woodlands. M.S. thesis. Virginia Polytechnical Institute and State University.
- Dahms, Walter G. 1949. How long do ponderosa pine snags stand? USDA Forest Service, Pacific Northwest Forest and Range Experiment Station Research Note 57, 3 p. Portland, Oreg.
- Keen, F. P. 1955. The rate of natural falling of beetle-killed ponderosa pine snags. Journal of Forestry 53:720-723.
- Lyon, L. Jack. 1977. Attrition of lodgepole pine snags on the Sleeping Child Burn, Montana. USDA Forest Service Research Note INT-219, 4 p. Intermountain Forest and Range Experiment Station, Ogden, Utah.
- Mannan, R. W. 1977. Use of snags by birds, Douglas-fir region, western Oregon. M.S. thesis. Oregon State University, Corvallis. 114 p.
- McClelland, B. Riley, and Sidney S. Frissell. 1975. Identifying forest snags useful for hole-nesting birds. Journal of Forestry 73:414-417.



Stage, Albert R., Nicholas L. Crookston,  
and William R. Wykoff. 1982. User's  
guide to the stand prognosis model.  
USDA Forest Service General Technical  
Report INT-133. Intermountain Forest  
and Range Experiment Station, Ogden,  
Utah.

Thomas, Jack Ward, Ralph G. Anderson, Chris  
Maser, and Evelyn L. Bull. 1979.  
Snags. p. 60-77. In Wildlife  
habitats in managed forests--the Blue  
Mountains of Oregon and Washington.

U.S. Department of Agriculture  
Agriculture Handbook No. 553.  
(Published in cooperation with the  
Wildlife Management Institute and the  
U.S. Department of the Interior Bureau  
of Land Management.) Washington, D.C.

Van Sickle, Charles, and Robert E. Benson.  
1978. The dead timber resource--  
amounts and characteristics. p. 127-  
146. In Proceedings of symposium on  
the dead softwood timber resources.  
Washington State University, Pullman.

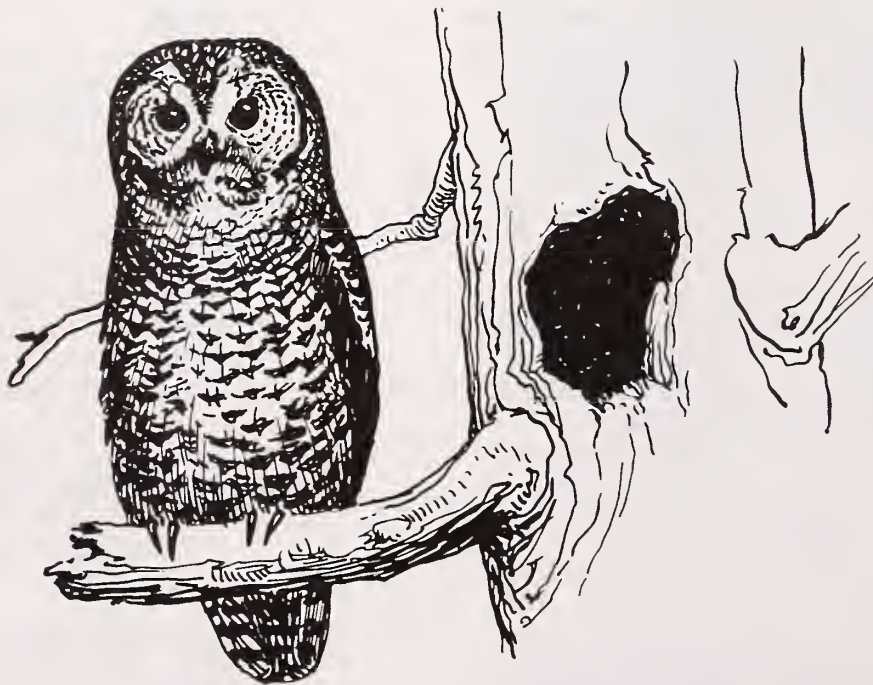

# Providing Snag Habitat for the Future<sup>1</sup>

Keith A. Menasco<sup>2</sup>

---

Abstract.--Two green trees in addition to 1.8 snags should be adequate to maintain sufficient snag numbers during a timber rotation. If a sufficient number of snags are not present then snags must be artificially created or more green trees must be retained. The amount of timber volume lost to provide snag habitat will amount to 4 percent of the total volume.

---

## INTRODUCTION

Snag dependent bird species can account for as much as 30 to 45 percent of the total bird population and may account for as much as 66 percent (Scott et al. 1980). These species are primarily insectivorous and are vital in the role of insect control (Thomas et al. 1979; Jackson 1979; Kroll and Fleet 1979; and many others). They are also important for aesthetic and ecological roles (Peterson 1980).

Articles have been written on the value of snags, sizes of snags selected by certain species of cavity-nesting birds, and an approach to determining quantitative numbers and sizes of snags to meet different needs of maximum potential woodpecker populations. Thomas et al. (1979) has compiled much of what is presently known about snag management.

I have written this paper to answer some basic questions in order to provide adequate snag habitat both now and in the future for snag dependent wildlife species. The Tonto National Forest, like many forests, has timber stands which are now being treated with a final removal cut (shelterwood harvest) which will eliminate the last of the yellow pines (large mature ponderosa pine, *Pinus ponderosa*) remaining in the overstory. The wildlife manager must know what the snag requirements are for his locality and must decide on the number and sizes of trees to be retained to provide for snag recruitment during the next timber rotation.

## SNAG REQUIREMENTS

The Tonto National Forest has 5 primary cavity-nesters (Table 1). Using the model developed by

Thomas et al. (1979), the number of snags required to meet the needs of all 5 species was determined (Table 2). Like Thomas et al. (1979), it was assumed that if the needs of the primary excavators were met then the requirements for all cavity users will also be met. Population levels below 40 percent of maximum potential were not considered viable (Thomas et al. 1979). Snags smaller than 15 inch DBH are used, however, they are used less than larger ones (Scott 1978). Therefore, I considered them of less importance and only snags greater than 15 inches were considered. All of the primary cavity-nesters found on the Tonto will nest in snags less than 20 inches. However, the acorn woodpecker, *Melanerpes formicivorus*, has additional snag requirements for food storage (granary trees). Acorn woodpeckers will select the largest snags in the area as their granary trees and these trees will average greater than 20 inches (Gutierrez and Koenig 1978; Trail 1980). It is not known if acorn woodpecker populations will be suppressed if there are no snags greater than 20 inches. However, it is believed that snag size is limiting and that acorn woodpecker populations will be suppressed if there are no snags greater than 20 inches (Walter D. Koenig, pers. comm.).<sup>3</sup> Therefore, I have included the acorn woodpecker's requirement for granary trees when computing snag numbers and I have assumed that acorn woodpeckers require snags in excess of 20 inches for granary trees.

Under present timber management direction we are managing timber on a 120 year rotation with the objective of growing and harvesting 18 to 20 inch trees. If we do not leave trees to grow larger than 20 inches then this size class of snags will be eliminated. Due to our limited understanding of the intricacies of forest communities I believe it would be a mistake to ever deliberately manage populations at a minimum viable level (40 percent). To allow for error I have used the 50 percent level as a minimum level.

---

<sup>1</sup>Paper presented at the Snag Habitat Management Symposium, Flagstaff, Arizona, June 7-9, 1983.

<sup>2</sup>Keith A. Menasco is a Wildlife Biologist, Tonto National Forest, Payson, Ariz.

---

<sup>3</sup>Koenig, Walter D. 1983. Personal conversation. Hastings Reservation, Univ. Calif., Berkeley.



Table 1.--Habitat requirements for the 5 primary cavity nesters found on the Tonto National Forest

	Min. Snag DBH in inches	No. Cavities excavated/year	Max. Pairs/100 acres	Snags required per 100 acres to support various percentages of maximum woodpecker populations. <sup>6</sup>									
				100%	90%	80%	70%	60%	50%	40%	30%	20%	10%
Acorn Woodpecker	≥20 <sup>(5)</sup>	3 <sup>(5)</sup>	3.8 <sup>(4)</sup>	171	154	137	120	103	86	68	51	34	17
	≥10 <sup>(3)</sup>	1 <sup>(3)</sup>											
Common Flicker	≥12 <sup>(2,3)</sup>	1 <sup>(2,3)</sup>	2.5 <sup>(2)</sup>	38	34	30	26	23	19	15	11	8	4
Hairy Woodpecker <sup>(1)</sup>		1 <sup>(3)</sup>	4 <sup>(2)</sup>	180	162	144	126	108	90	72	54	36	18
		3 <sup>(2)</sup>											
Lewis Woodpecker	≥12 <sup>(3)</sup>	1 <sup>(2,3)</sup>	6.7 <sup>(2)</sup>	101	90	80	70	60	50	40	30	20	10
	≥15 <sup>(2)</sup>												
Williamson's Sapsucker	≥12 <sup>(2,3)</sup>	1 <sup>(2,3)</sup>	20 <sup>(2)</sup>	150	135	120	105	90	75	60	45	30	15

<sup>1</sup>Indicator species for Tonto National Forest.

<sup>2</sup>Thomas et al. 1979.

<sup>3</sup>Bull 1978.

<sup>4</sup>Used territory size of 26.3 (Trail 1980 because of lack of density and diversity of oaks in ponderosa pine type).

<sup>5</sup>Acorn woodpeckers require granary trees that averaged greater than 20 in. DBH (Trail 1980; Gutierrez and Koenig 1978). Number of activities excavated also include trees required for granaries.

<sup>6</sup>Number of snags computed using the formula:  $S=C(16-1)N$ . Where pairs 100 acres (Thomas et al. 1979).

Table 2.--Total number of snags required per 100 acres by size class to support various percentages of maximum woodpecker populations for all 5 species of primary excavators found on the Tonto National Forest. Note: Large snags may be substituted for smaller ones when deriving total snag numbers.

	100%	90%	80%	70%	60%	50%	40% <sup>(2)</sup>	30%	20%	10%
≥20"DBH	171	154	137	120	103	86	68	51	34	17
≥15" DBH <sup>1</sup>	9	8	7	6	5	4	4	3	2	1
TOTAL	180	162	144	126	108	90	72	54	36	18

<sup>1</sup>A minimum of 15" DBH was used based on study by Scott (1978) that found a significantly higher use in snags ≥ 15" DBH

<sup>2</sup>Minimum viable population.

There is a noticeable lack of snags present today on the Tonto because, prior to 1973, snags were routinely cut. No intensive surveys have been conducted, however, it is estimated that there are approximately only 50 snags per 100 acres (>15 in. DBH) in managed stands. Timber found on slopes too steep for conventional logging methods probably have in excess of 180 snags per 100 acres.

#### SNAG DENSITIES

To determine the number and sizes of trees to be retained during a final removal shelterwood cut it is necessary to predict snag numbers. Bull et al. (1980) developed a model that predicts the number of snags present at any given year providing that the beginning snag and tree density, annual fall rate of snags and annual mortality of green trees are known. For simplification Norm Cimon (pers. comm.)<sup>4</sup> modified the model for use with a programmable hand held calculator. The modified model is presented below.

$$S_n = (S_o - \frac{T_o M}{F-M} \times (1-F)^n) + (\frac{T_o M}{F-M} \times (1-M)^n).$$

- Where:  $S_n$  = snag number in the nth year  
 $S_o$  = snag density at year zero  
 $T_o$  = green tree density at year zero  
 $M$  = mortality rate of green trees  
 $F$  = falling rate of snags  
 $n$  = the year

Inherent model deficiencies are that all size classes, annual mortality of green trees, and falling rate of snags are static when in reality size classes change over time, mortality increases with age (size) and falling rates of snags vary with age and size.

Densities of green trees required for snag recruitment to maintain viable wildlife populations during a 120 year timber rotation were determined using the above model. The number of snags was predicted for each tenth year using different initial densities of residual green trees. I have assumed that a sawtimber sale will be conducted at year 70, 90, and 110 and 90, 50, and 35 trees, respectively, will remain following harvest. At year 130 there will be either a removal or a seed cut. Mortality rates for green ponderosa pine trees were determined using a model developed by Kasmussen and Ffolliott<sup>5</sup> (Table 3). The model was developed using data from the Continuous Forest Inventory (1960-70) for the Southwestern Region of the USDA Forest Service. To make the snag prediction model respon-

Table 3.--Annual mortality rates of ponderosa pine by size classes for the Southwest.

Tree size by DBH in inches	Annual mort. rates	Tree size by DBH in inches	Annual mort. rates
15	0.36	24	0.54
16	0.37	25	0.57
17	0.38	26	0.60
18	0.40	27	0.64
19	0.41	28	0.68
20	0.43	29	0.73
21	0.46	30	0.77
22	0.48	31	0.82
23	0.51		

sive to an increase in size with age it was assumed that a 20 inch ponderosa pine tree would grow at an average increment of 1 inch during each decade.

The rate of fall for snags depends primarily on the time elapsed since death (age). However, the rate also depends on the size of the snag and the environmental conditions (Keen 1955). Both Keen (1955) and Cunningham et al. (1980) found a rapid falling rate at first which slows with time. Keen (1955) found that only the large snags will persist. Bull et al. (1980) reported that 10 to 20 inch snags had a rate of fall more than 7 times greater than snags larger than 20 inches. Cunningham et al. (1980) did not compare rate of fall with size. The snags studied by Cunningham et al. (1980) in the Southwest persisted much longer and, therefore, had a lower falling rate than those studied by Keen (1955) or the falling rates used by Bull et al. (1980). This was attributed to a dryer climate (Cunningham et al. 1980).

At any one time there will be snags with different ages and sizes and, therefore, with different falling rates. To utilize the snag prediction model it is necessary to have a constant or annual falling rate. Cunningham et al. (1980) found the relation between age and percent standing to be curvilinear. To derive the "best fit" annual fall rate I fitted the best straight line to the data reported by Cunningham et al. (1980) using a linear regression equation. The slope of this line (1.48) was used as the annual falling rate for snags. Because Cunningham et al. (1980) did not include size, the falling rate of 1.48 percent was used only for snags greater than 20 inch DBH. A falling rate 7 times greater (10.3 percent) was used for snags less than 20 inches (Bull et al. 1980).

Using a falling rate of 1.48 percent, 2 green trees (>20 in. DBH) in addition to 1.8 snags (>20 in. DBH) per acre will maintain enough snags throughout the rotation for viable populations (Fig. 1). However, if there are only 0.5 snags per acre as is the present condition over much of the Tonto then the population will remain suppressed below minimum viable levels (40 percent) until the stand reaches an adequate size level to begin producing snags on its own. Species requiring greater than 20 inch DBH snags will remain suppressed throughout the whole rotation until the stand averages 20 inches (Fig. 2).

<sup>4</sup>Cimon, Norm. 1983. Personal correspondence. USDA Forest Service, Range and Wildl. Habitat Lab., La Grande, Oregon.

<sup>5</sup>Rasmussen, William O. and Peter F. Ffolliott. (n.d.) A model to predict snag development. Unpublished manuscript. School of Renewable Natural Resources, Univ. of Ariz., Tucson.



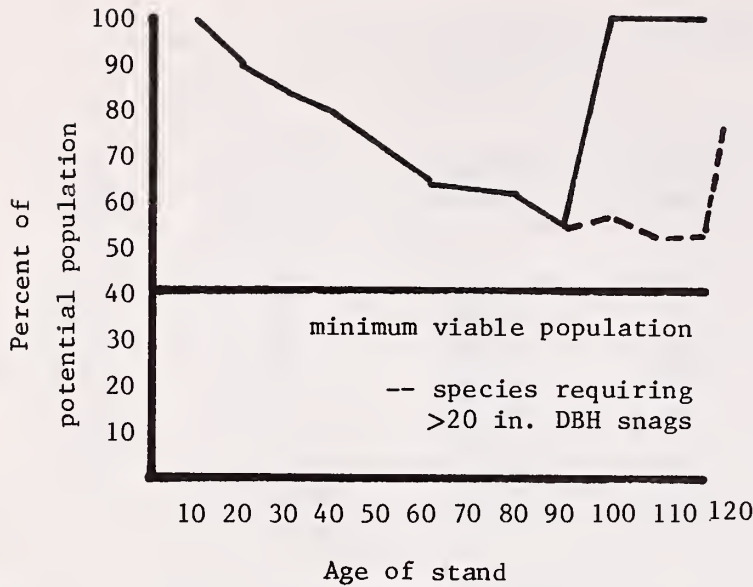

Figure 1.--Percent of potential population existing over time beginning with 1.8 snags plus 2 green trees (all greater than 20 in. DBH). Stand will average 15 inch DBH at year 90 and 20 inch DBH at year 120.

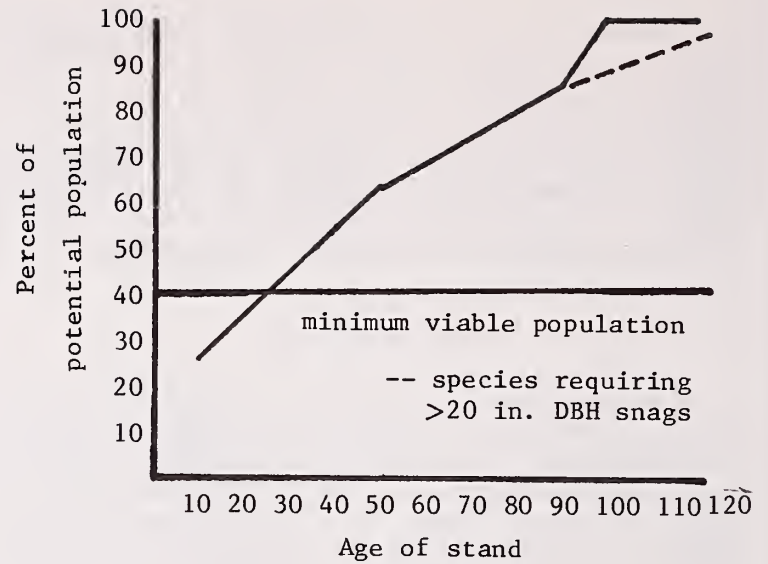

Figure 3.--Percent of potential population existing over time beginning with 0.5 snags plus 6 green trees per acre (all greater than 20 in. DBH). Stand will average 15 inch DBH at year 90 and 20 inch DBH at year 120.

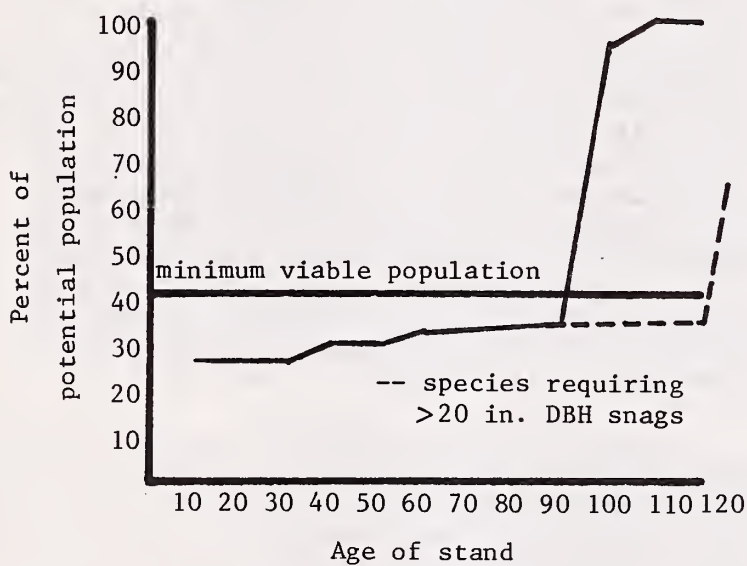

Figure 2.--Percent of potential population existing over time beginning with 0.5 snags plus 2 green trees per acre (all greater than 20 in. DBH). Stand will average 15 inch DBH at year 90 and 20 inch DBH at year 120.

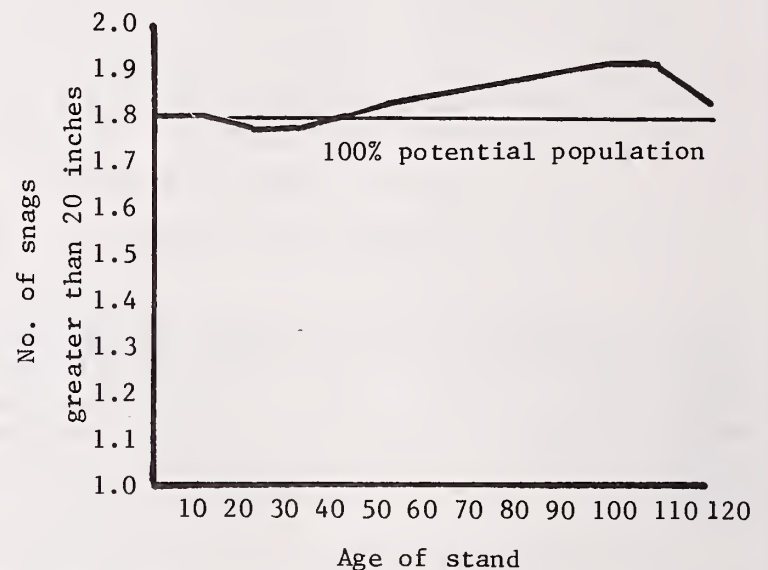

Figure 4.--The number of snags existing over time beginning with 1.8 snags and 6 green trees per acre (all greater than 20 inch DBH). There will be additional snags in the 15-20 inch DBH size class beginning at year 90.

The manager has 2 options to alleviate this problem. Either snags can be artificially produced or more green trees can be retained to accelerate snag recruitment. If 6 trees are retained the potential population will increase above the minimum viable level in 15 years (Fig. 3). If 4 trees are left it will take almost 50 years. To maintain snag levels at 1.8 snags (20 inch DBH) per acre it will require the retention of only 6 trees per acre (Fig. 4).

#### ECONOMICS

Using RMYLD computer programming (Edminster 1978) yields were calculated for an entire rotation to determine what percent of the total volume was being lost for snag recruitment (Table 4). A theoretical even-aged, one-storied stand was used based on a site index of 70. Calculations were initiated when the stand was 40 years old, with a basal area of 79 square feet, and an average DBH of 6 inches. Thinnings were scheduled at 20 year intervals. The stand was free of dwarf mistletoe.

Table 4.--The amount of timber volume lost during a rotation for the purpose of providing residual trees for snag replacement.

No. of trees	DBH (in.)	Vol. lost cu. ft.	Total vol. harvested cu. ft.	Stand age at last cutting	Percent lost
2	21.7	152	3818	120	4.0
3	21.7	228	3742	120	6.1
6	18.5	300	3290	100	9.1

#### CONCLUSIONS

It is important to have adequate snag numbers when going into a new timber rotation. With adequate snag numbers initially, it will only require 2 green trees in excess of 20 inches for a loss of only 4 percent of the total timber volume for that rotation.

The predictions made in this paper are only as good as the data used in the model. I feel comfortable with the mortality data, however, I do not with the snag falling rate data. More research is needed to determine true falling rates. The data reported by Cunningham et al. (1980) were collected in a mature forest situation. I believe the falling rates will be much higher for snags that are widely spaced and exposed, such as in stands that are composed of saplings. I cannot overemphasize the significance of this. If a falling rate of 3.2 percent (falling rate in Pacific Northwest, Bull et al. 1980) is used it will require 6 trees per acre instead of 2 and it will be infeasible to leave enough residual trees in a managed stand to maintain 1.8 snags per acre for the duration of the stand. An increase in residual trees means a larger trade-off.

Other factors that must be considered are rate of blow-downs for the residual trees left for snag recruitment and amount of theft occurring on present snags for firewood. Once a stand is regenerated it will not be able to produce snags of sufficient size for approximately 80 years. Any impacts on the residual green trees or snags must be foreseen or there may be a shortage of snags during a time when nothing can be done until the stand again reaches an average size large enough for wildlife snag requirements.

#### ACKNOWLEDGEMENTS

My appreciation to Evelyn Bull and Norm Cimon for their assistance on the use of the snag prediction model. I also wish to thank Pete Ffolliott for the ponderosa pine mortality model. I am grateful to Jim Mercer and Bill Burton for running the RMYLD programs and to Gail Wygant for typing part of the manuscript.

#### LITERATURE CITED

Bull, Evelyn L. 1968. Specialized habitat requirements of birds: snag management, old growth, and riparian habitat. P.74-82. In Nongame bird habitat management in the coniferous forests of the western United States: Proceedings

- of the workshop. USDA Forest Service. GTR PNW-64. Washington, D.C.
- Bull, Evelyn L., Asa D. Twombly, and Thomas M. Quigley. 1980. Perpetuating snags in managed mixed conifer forests of the Blue Mountains, Oregon. P.325-336. In Management of western forests and grasslands for nongame birds: Proceedings of the workshop. (Salt Lake City, Utah, Feb. 11-14, 1980) USDA Forest Service General Tech. Rep. INT-86, 535 p. Intermountain For. and Range Exp. Stn., Ogden, Utah.
- Cunningham, James B., Russell P. Balda, and William S. Gaud. 1980. Selection and use of snags by secondary cavity-nesting birds of the ponderosa pine forest. USDA Forest Service Res. Paper RM-222. 15p. Rocky Mt. For. and Range Exp. Stn., Fort Collins, Colo.
- Edminster, Carleton B. 1978. RMYLD: Computation of yield tables for even-aged and two storied stands. Res. Pap. RM-199, 26p. USDA Forest Service Rocky Mt. For. and Range Exp. Stn., Fort Collins, Colo.
- Gutierrez, R.J. and Walter D. Koenig. 1978. Characteristics of storage trees used by acorn woodpeckers in two California woodlands. J. For. 76(3): 162-164.
- Jackson, Jerome A. 1979. Insectivorous birds and North American ecosystems. p. 1-5. In The role of insectivorous birds in forest ecosystems. Academic Press. 381p.
- Keen, F.P. 1955. The rate of natural falling of beetle-killed ponderosa pine snags. J. For. 53: 720-723.
- Kroll, Jones C. and Robert R. Fleet. 1979. Impact of woodpecker predation on over-wintering within-tree populations of the southern pine beetle (Dendroctonus frontalis). p. 269-282. In The Role of insectivorous birds in forest ecosystems. Academic Press. 381p.
- Peterson, Steven R. 1980. The role of birds in western communities. p. 6-12. In Management of western forests and grasslands for nongame birds: Proceedings of the workshop. (Salt Lake City, Utah, Feb. 11-14, 1980) USDA Forest Service General Tech. Rep. INT-86, 535p. Intermountain For. and Range Exp. Stn., Ogden, Utah.
- Scott, Virgil E., Jill A. Whelan, and Peggy L. Svoboda. 1980. Cavity-nesting birds and forest management. p. 311-324. In Management of western forests and grasslands for nongame birds: Proceedings of the workshop. (Salt Lake City, Utah, Feb. 11-14, 1980). USDA Forest Service Gen. Tech. Rep. INT-86, 535p. Intermountain For. and Range Exp. Stn., Ogden, Utah.



Thomas, Jack W., Ralph G. Anderson, Chris Maser,  
and Evelyn L. Bull. 1979. Snags. p.60-77.  
In Wildlife habitats in managed forests the  
Blue Mountains of Oregon and Washington, USDA  
Forest Service. Ag. Hand. No. 553, 512p.

Trail, P.W. 1980. Ecological correlates of social  
organization in a communally breeding bird,  
the Acorn Woodpecker, Melanerpes formicivorus.  
Behav. Ecol. Sociobiol. 7:83-92.



# Cavity-Nesting Bird Response to Declining Snags on a Burned Forest: A Simulation Model<sup>1</sup>

Martin G. Raphael<sup>2</sup>

---

Abstract.--I present a simple model to estimate population sizes of primary (PCN) and secondary (SCN) cavity nesting birds in relation to a declining snag population following fire. The model assumes that PCN are limited by snag suitability, intraspecific territoriality, or snag density during successive time periods. Two examples illustrate these patterns, as well as the impact of snag harvest on subsequent bird populations. A FORTRAN program, CNBIRDS, performs all computations.

---

## INTRODUCTION

Snags are a dynamic resource: their populations undergo temporal changes in both quality (snags decay with age) and quantity (new snags appear and existing snags fall with time). Little attention has been focused on the implications of these temporal trends for wildlife. The snag management model developed by Thomas et al. (1979), for example, gave estimates of the numbers and sizes of snags required by woodpeckers, but failed to take into account attrition of snags with time. Bull et al. (1980) have, however, presented a formula for estimating the future density of snags given their annual falling rate and starting density. In this paper I extend the latter approach using a computer simulation model (CNBIRDS) to track numbers of snags and to estimate resulting numbers of primary (PCN) and secondary (SCN) cavity-nesting birds through time as snags decay and fall. Using a burned Sierra Nevada pine-fir forest as an example, I examine the response of birds to reduced densities of snags with time under both natural and managed conditions.

## THE MODEL

To construct the model, I considered 8 combinations of snag dbh and species. Starting values for the number of snags present in each category are decreased each year by a proportion calculated

using a generalized poisson distribution function for each category. The shapes of these decay curves were adjusted to match empirical data reported by Raphael and White (in press).

At the start of each year PCN are added to the system, subject to several constraints. First, the model assumes that each pair of PCN requires a specified minimum number of snags. Secondly, each PCN has a maximum population size determined by intraspecific territoriality. Maximum values used in this model were based on average densities from published breeding censuses (Raphael and White 1978) for each of the 8 species likely to nest in burned pine fir forest of the Sierra Nevada (Table 1). Thirdly, I modeled the proportion of each species' nests expected in each of the 8 snag categories (Table 1). Finally, each species requires snags in a particular range of decay-states; the model incorporates a minimum snag age before snags become acceptable, under the assumption that age and decay are directly related.

The population of SCN was modeled assuming that numbers are limited by either the number of suitable cavities or a fixed maximum, again based on intraspecific territoriality. The number of suitable cavities in each snag type resulted from the following considerations. First, each PCN excavates from 1-3 cavities per year (see Bull et al. 1980). The model assumes that all cavities, except those of Pygmy Nuthatch, are available to SCN. Next, the current year's cavities are added to those that exist from the previous year in each snag type. With the passage of a year, a number of these cavities are lost as the snags containing them fall; this number of lost cavities is proportional to the annual rate of fall of each snag type. Finally, the number of cavities at the start of the next year is used to set the potential number of SCN. If this potential exceeds the previously specified maximum density (read in as an input item), the model sets the current population

---

<sup>1</sup>Paper presented at the snag habitat management symposium. [Northern Arizona University, Flagstaff, Arizona, June 7-9, 1983.]

<sup>2</sup>Martin G. Raphael is Staff Research Associate, Department of Forestry and Resource Management, University of California, Berkeley, California 94720.



Table 1.--Proportion of nests expected in each combination of snag species and diameter class (dbh, cm), maximum density of PCN, and initial snag densities.<sup>1</sup>

Bird Species	Fir <sup>2</sup>				Pine <sup>3</sup>				Sample size <sup>4</sup>	Maximum density (pairs/100 ha)
	<23	23-37	38-53	>53	<23	23-37	38-53	>53		
Pygmy Nuthatch ( <i>Sitta pygmaea</i> )	0	0.36	0.21	0.14	0	0.07	0.11	0.11	28	57.6
Hairy Woodpecker ( <i>Picoides villosus</i> )	0	0.22	0.30	0	0	0.13	0.22	0.13	23	12.4
Black-backed Woodpecker ( <i>Picoides arcticus</i> )	0	0.12	0.13	0.12	0	0.38	0.25	0	8	1.0
Red-breasted Sapsucker ( <i>Sphyrapicus ruber</i> )	0	0.04	0.07	0.56	0	0	0.04	0.29	45	4.0
Williamson's Sapsucker ( <i>Sphyrapicus thyroideus</i> )	0	0	0.04	0.45	0	0.02	0.08	0.41	49	4.0
White-headed Woodpecker ( <i>Picoides albolarvatus</i> )	0	0.08	0.25	0.34	0	0.08	0.08	0.17	12	5.7
Northern Flicker ( <i>Colaptes auratus</i> )	0	0.11	0.21	0.20	0	0.03	0.17	0.28	65	7.2
Lewis' Woodpecker ( <i>Melanerpes lewis</i> )	0	0	0.16	0.38	0	0	0.22	0.24	37	7.2
Initial density of snags (N/100 ha)	4472	5300	1455	402	4413	6684	1987	260		

<sup>1</sup>Data from Raphael and White (1978), Raphael and White (in press), and Raphael (unpublished).

<sup>2</sup>Includes *Abies concolor*, *A. magnifica*.

<sup>3</sup>Includes *Pinus contorta*, *P. jeffreyi*, *P. ponderosae*.

<sup>4</sup>Number of nests examined to calculate proportion.

to that maximum, and there are surplus (unused) cavities.

The major features of the model are summarized in Figure 1. Basically, with the passage of each year a proportion of snags fall. The remaining snags are counted in each type and the program calculates the numbers of PCN and SCN for the current year. When all snags have fallen (or when the number of years reaches a preset maximum), the program stops. This is a simple model, but, as I hope to show with the following examples, a potentially useful one.

#### EXAMPLE ONE: NO TREATMENT

##### Snag Decline

The first example is designed to examine the reponse of cavity-nesting birds to the pattern of snag-fall on a burned forest assuming that no snags are harvested following the burn. The model was run for 45 years. I specified that each pair of PCN required at least 48 snags (from Thomas et al. 1976) and that each PCN excavated only 1 cavity per year. I also set the maximum density of SCN at 240 pairs per 100 ha (calculated from the upper 95% confidence interval of the mean breeding density of SCN from 63 censuses published in *American Birds* [Jackman 1974]). Starting values for the number of snags in each category (Table 1)

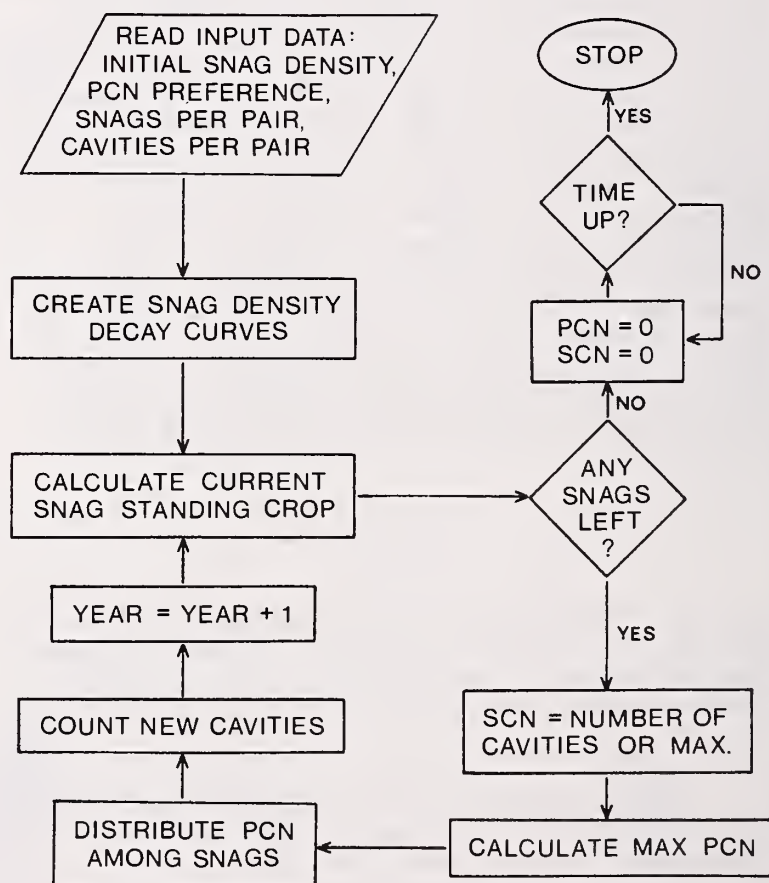

Figure 1.--General flow chart for program CNBIRDS. Data on snag decay rates and use by PCN and SCN are maintained separately for each of 8 snag size and species combinations (see Table 1).

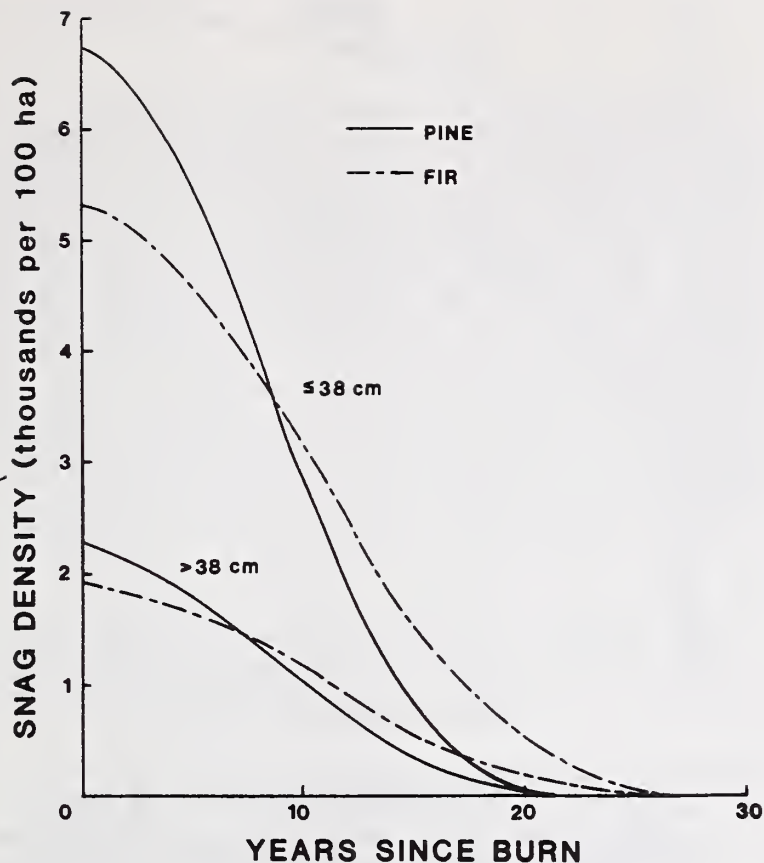

Figure 2.--Simulated decline of snag density following fire, by species and dbh class. Snags less than 23 cm dbh are not included.

were determined from field data (Raphael and White, in press).

Fifty percent of the snags fell by the first 10 years (Fig. 2); the falling rate slowed thereafter. Larger snags fell at a slower rate than smaller ones, and fir snags fell slower than pine (Fig. 2). By year 20 nearly all of the pine snags had fallen; by year 25 nearly all the fir snags had fallen. By year 35, no snags were left.

#### Bird Response

The simulated response of cavity-nesting birds (Fig. 3) revealed several interesting

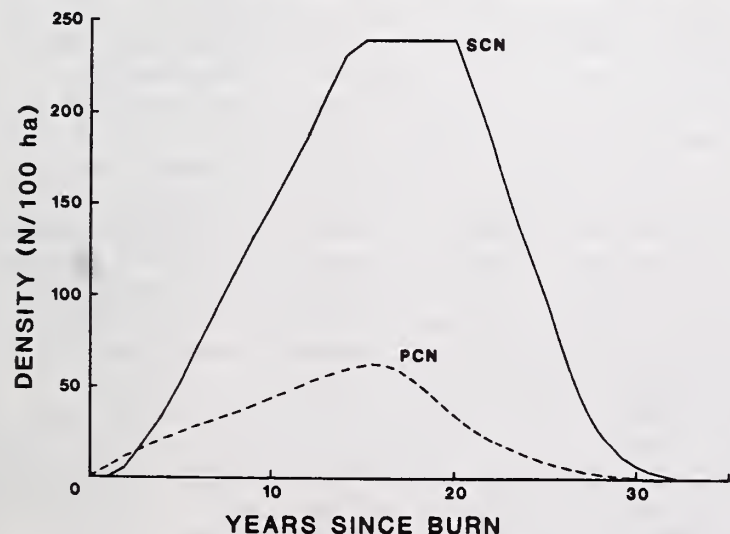

Figure 3.--Simulated response of cavity-nesting birds to changing snag density following fire.

patterns. First, density of PCN did not reach a maximum until year 18. Until then, snags were abundant but bird numbers were limited by the lack of sufficiently decayed snags or by their territoriality. The differential responses of selected PCN species are illustrated in Figure 4. Hairy Woodpeckers are opportunistic species that rapidly invade burned forests (Koplin 1969) and are capable of excavating nests in harder (more recently killed) snags (Raphael and White, in press). Northern Flicker and Lewis' Woodpecker require softer snags for nesting; these species do not reach maximum densities until year 15 and 19, respectively (Fig. 4). Other species (not illustrated) achieved maximum densities at intermediate years.

Beyond 18 years, snags were sufficiently decayed for all species, but snag density had become too low to support maximum densities of PCN. The PCN population crashed as snag numbers were further reduced; none remained by year 30.

The populations of SCN lagged behind the PCN for the first 2 years, until the supply of cavities began to build up. Thereafter, SCN numbers rose rapidly due to the accelerating rate of cavity production and the larger inventory of cavities persisting from previous years. Maximum density was reached in year 16, 2 years earlier than achievement of maximum density of PCN. The SCN maximum persisted until year 22. During this period, the model assumed that SCN were limited by territoriality rather than availability of cavities. Beyond year 22, the accelerating rate of snag fall caused the number of cavities to decline to the extent that SCN were again limited by cavity availability. It is interesting that the SCN persisted at maximum density for 3-4 years beyond the year when PCN began declining. Apparently, PCN became limited by numbers of suitable snags while SCN were still finding surplus cavities present from previous years. This is an easily tested prediction resulting from the model.

I used the periodic breeding census from a burned study plot at Sagehen Creek to test this prediction. Ten censuses are available, covering the period from 6 to 22 years following fire (Bock and Lynch (1970, Bock et al. 1978, Harris and Raphael 1982, Yoder-Williams, in press). Unfor-

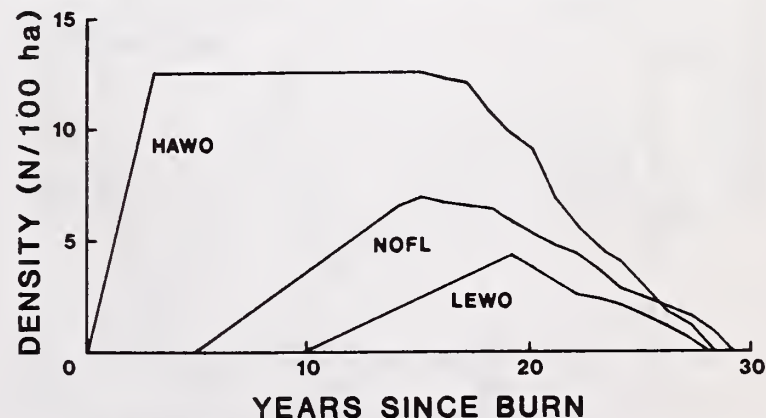

Figure 4.--Response of selected PCN to changing snag density following fire. Species are Hairy Woodpecker (HAWO), Northern Flicker (NOFL), and Lewis' Woodpecker (LEWO)



tunately, the census data do not support the model prediction (Fig. 5). Both PCN and SCN declined at nearly the same rate over this 15 year period. Perhaps the model is wrong, or perhaps the small size of the study grid (8.5 ha) results in such exaggerated year-to-year variation that subtle differences are masked. In addition, comparison of figures 3 and 5 shows that modeled population sizes of PCN and especially SCN are higher than those actually estimated from the censuses. Further monitoring of this plot, and comparison with other long-term censuses on burned plots will be necessary to validate model predictions.

One obvious result of this exercise is an explicit demonstration of the futility of using ratios of the number of snags with cavities to the number without cavities as an estimate of the snag requirements of PCN, as has been suggested by Thomas et al. (1979). Reference to Figure 3 shows that this ratio will change constantly with the history of the plot. In year 1, for example, only a few snags will have cavities. In year 25, however, probably 100% of the remaining snags will contain at least one cavity. Thus, conclusions resting on such ratios must be tempered with knowledge of the age of the snags on the study plots.

EXAMPLE TWO: EFFECTS OF SNAG HARVEST

Program CNBIRDS can also be used to explore impacts of snag treatments on cavity-nesting birds. In this section I examine the response of birds to reduced initial densities of snags, simulating various snag harvest levels immediately following fire. My measure of bird response was derived from the accumulated total number of birds (both PCN and

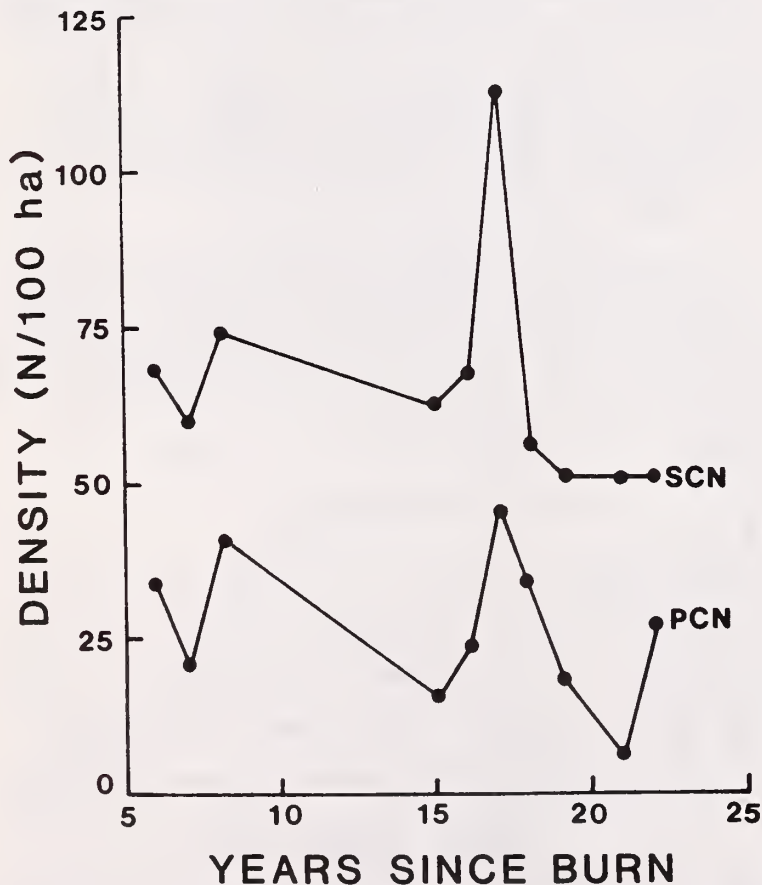

Figure 5.--Censused density of cavity-nesting birds following fire on a Sierra Nevada forest.

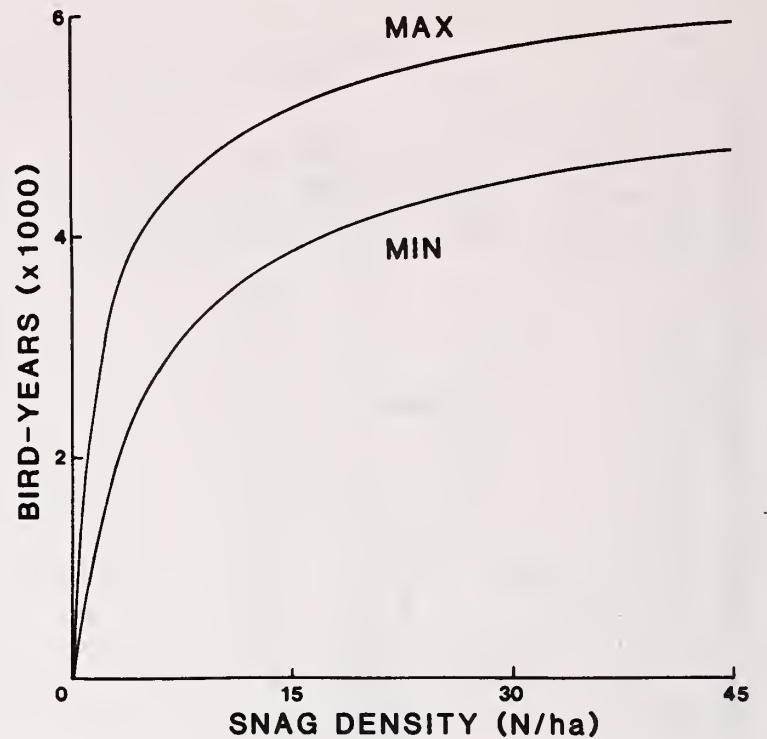

Figure 6.--Simulated response of cavity-nesting birds to changing initial density of snags greater than 38 cm dbh. The upper curve (max) was computed assuming that each pair of PCN requires 15 snags and excavates 3 cavities per year; the lower curve (min) assumes 48 snags per pair and 1 cavity.

SCN) over all years. For each run, this amounted to an integration of the curves illustrated in Figure 2. If, for example, 5 pairs existed in each of 4 years, the total bird-years would equal 20.

I used 19 snag treatment levels. These varied from 1% to 10% of the pretreatment snag density (in 1% increments) and from 20% to 100% (in 10% increments). I also varied 2 of the major model assumptions: the number of cavities excavated per pair could be 1, 2, or 3 and the number of snags required per pair could be either 15 or 48. Thus, I ran the model a total of 114 times to include all possible combinations of snag density, snag requirements, and cavities excavated.

Total bird-years rose dramatically from the 0 to 10% treatment level, corresponding to 0 to 4.5 snags >38 cm per ha (Fig. 6). The maximum number of bird-years for any particular snag density occurred where I assumed a snag requirement of only 15 per pair and a cavity excavation rate of 3 per pair. The lowest response occurred under assumptions of 48 snags and 1 cavity per pair. Because all other combinations yielded intermediate values, I display only these extremes. Beyond the 15 snags per ha (30%) level, bird response rose relatively slowly. The model predicted, then, that optimum snag densities under the present constraints should be between 7 and 15 snags per ha. I find it significant that tripling the assumed snag requirements and cavity production resulted in about only a 17% decrease in bird use at any snag density. It would appear that birds are much more sensitive to changes in snag density than variation of model parameters within the range I tested.

## CONCLUSIONS

Program CNBIRDS seems to be a useful model to examine relationships between numbers of snags and numbers of cavity nesting birds and changes in both that occur through time when snags are not replaced. The model can be used to develop a number of testable hypotheses regarding the relative numbers of PCN and SCN and their respective rates of increase and decrease with time. Even if the model proves unrealistic, it can be useful as a classroom tool to demonstrate a simple but thought-provoking example of the coupling between wildlife populations and their habitats. Finally, the program can be used to examine the potential consequences of harvesting any proportion of any combination of snag diameter, and species.

A listing of program CNBIRDS, which is written in FORTRAN IV for CDC machines and consists of a main program and 8 subroutines, is available from the author in request.

## ACKNOWLEDGMENTS

Field studies were funded by Susan Raphael and the USDA Forest Service, Pacific Southwest Region. Computing time was provided by the University of California, Department of Forestry and Resource Management. I thank John Menke for programming advice.

## LITERATURE CITED

- Bock, C.E., and J.F. Lynch. 1970. Breeding bird populations of burned and unburned conifer forest in the Sierra Nevada. *Condor* 72: 182-189.
- Bock, C.E., M. Raphael, and J.H. Bock. 1978. Changing avian community structure during early post-fire succession in the Sierra Nevada. *Wilson Bulletin* 89:119-123.
- Bull, E.L., A. D. Twombly, and T.M. Quigley, 1980. Perpetuating snags in managed mixed conifer forests of the Blue Mountains, Oregon. p. 325-326. *In* Management of western forests and grasslands for nongame birds. USDA Forest Service General Technical Report INT-86, 535 p. Intermt. For. and Range Exp. Stn., Ogden, Utah.
- Harris, R.D., and M.G. Raphael. 1982. Breeding-bird census: burned pine-fir forest, California. *American Birds* 36:88.
- Jackman, S. M. 1974. Woodpeckers of the Pacific Northwest: their characteristics and their role in the forest. 147 p. M.S. thesis, Oregon State University, Corvallis, Oregon.
- Koplin, J. R. 1969. The numerical response of woodpeckers to insect prey in a subalpine forest in Colorado. *Condor* 71:436-438.
- Raphael, M. G., and M. White. 1978. Snag management guidelines for habitat types on the western slope of the Sierra Nevada. 69 p. Unpublished report to USDA Forest Service, Pacific Southwest Forest and Range Experiment Station, Fresno, California.
- Raphael, M. G., and M. White. In press. Use of snags by cavity-nesting birds in the Sierra Nevada Mountains. *Wildlife Monographs*.
- Thomas, J. W., R. J. Miller, H. Black, J.E. Rodiek, and C. Maser. 1976. Guidelines for maintaining and enhancing wildlife habitat in forest management in the Blue Mountains of Oregon and Washington. p. 452-476.
- Thomas, J. W., R. G. Anderson, C. Maser, and E. L. Bull. 1979. Snags. p. 60-77. *In* Wildlife habitats in managed forests--the Blue Mountains of Oregon and Washington. USDA Forest Service Agriculture Handbook No. 553, 512 p. U.S. Govt. Print. Office, Washington, D.C.
- Yoder-Williams, M. P. In press. Breeding-bird census: burned pine-fir forest, California. *American Birds*.



# Predictive Models for Snag Nesting Birds<sup>1</sup>

Russell P. Balda, William S. Gaud, Jeffrey D. Brawn<sup>2</sup>

---

Abstract.--Multiple regression models were developed and their predictive power tested for the five common secondary cavity nesting birds in the ponderosa pine forests. Variables included in the regression analysis included seven vegetation ones and 11 climatic ones. All models were highly significant and explained between 50 and 89 percent of the variation in breeding bird density. Snag density, which appeared as an important variable in four of five models, had a positive affect on breeding bird density. Snags are the most important variable determining density of most of the secondary cavity nesters.

---

## INTRODUCTION

Populations of animals demonstrate, by their densities and reproductive output, a complex set of responses to a vast array of environmental variables. Theoretically, when resource levels are high and conditions hospitable, populations should show a numerical response and increase. Opposite conditions should cause a decrease. In practice, however, the interactive complexity of the factors affecting populations make it difficult, and at times, impossible to understand the underlying causes of population fluctuations. As Karr (1980) points out, temperature-moisture regimes, seasonality, vegetation structure, food resources, interspecific coevolutionary forces, and resource utilization patterns, all may interact in a complex manner to determine community structure. Biogeographic phenomena must also be considered, as a species that has not encountered a specific habitat type cannot be a candidate to breed there. Social interactions may also play a role in restricting population size. The above list will also determine species specific densities, but we know of no study that has successfully integrated all the above variables into a useful quantitative model with predictive power for any habitat-type in North America.

One goal of population ecology is to obtain a list of the prime, but specific, environmental variables that influence changes in population density. To note that temperature-moisture regimes are important does little beyond focusing

attention on particular kinds, or sets, of variables to be measured. Once these variables have been identified, it is necessary to measure and manipulate them in a way that has meaningful application to the specific animal under study. Predictive models will be most easily constructed for species that have conspicuous, easily measured resource needs. Such is the case with snags and secondary cavity nesting birds. These birds nest in natural cavities or those excavated by woodpeckers and thus are limited by the number of suitable cavities (Balda 1975; von Haartman 1957; Zeleny 1972). One must be cautious, however, in attempting to search for a single factor that influences population density. Secondary cavity nesters have complex resource needs and no single factor should have overwhelming predictive value.

The objectives of this study were:

1. To identify environmental variables (weather and habitat) that affect the densities of secondary cavity nesters in ponderosa pine forests.
2. To develop species specific, and guild models that explain and predict population fluctuations of secondary cavity nesters in ponderosa pine forest.
3. To test the accuracy of the predictive models to determine how robust they are.

## METHODS AND DATA BASE

In order to construct realistic models that have accurate predictive power, two important factors must be considered. First, if the model is to have predictive value for a given habitat-type, then it is important that data be gathered from a number of stands that are representative of the variation that exists in this habitat-type. Second, if population densities vary between years

---

<sup>1</sup>Paper presented at the Snag Habitat Management Symposium, Northern Arizona University, Flagstaff, June 7-9, 1983.

<sup>2</sup>Russell P. Balda is Professor of Biology, Northern Arizona University; William S. Gaud is Associate Professor of Biology, Northern Arizona University; Jeffrey D. Brawn is Research Associate, Northern Arizona University, Flagstaff, Arizona.



but vegetation does not then data must be gathered over a number of years in order to sample extreme between year variation. Weather may be influential in these variations and should be monitored at the same time (Fretwell 1972).

Some of the data used to construct the models presented herein were first published by Cunningham et al. (1980) and Szaro and Balda (1979). Additional climatic and vegetation variables have been added.

Bird densities in the ponderosa pine forest were obtained using the spot-map method on eight different study plots between 1973 and 1978 (table 1). A total of 21 breeding bird years were used to construct the model. Thus, the data base is broad (eight study plots) and has depth (two to four years per plot).

Table 1.--Study sites used to build and test a model of secondary cavity nesters in the ponderosa pine forest

Year	Study Sites							
	PNA	WS 8	WS 13	WS 14	WS 17	GF	RP	MT
1973			X	X	X			
1974		X	X	X	X			
1975	X	X	X	X	X			
1976	X	X		X				
1977						X	X	X
1978						X	X	X
1979		*	*		*			
1980		*	*		*			

X Data used to build model

\* Data used to test model

Weather data were gathered from six different sites, all within three km of a given study plot. Twenty-two different independent weather variables were calculated but only 11 were used as the others were linear combinations of those chosen for inclusion (table 2). Six variables measured precipitation and five measured temperature. Weather data were collected each year of censusing, and divided into periods of the year that were considered relevant to the birds.

Table 2.--Weather variables used in model construction

Variable	Inclusive Dates
Precipitation	25 Mar. - 2 June
Precipitation	(P)* 8 Oct. - 2 Dec.
Precipitation	8 Apr. - 2 June
Snow	30 July - 18 Nov.
Snow	(P) 19 Nov. - 7 Apr.
Rain	8 Apr. - 2 June
Degree Days	(P) 1 Jan. - 25 Mar.
Degree Days	1 Jan. - 2 June
$\bar{x}$ High Temp.	30 July - 18 Nov.
$\bar{x}$ Low Temp.	30 July - 18 Nov.
$\bar{x}$ High Temp.	(P) 19 Nov. - 7 Apr.

\* Previous to breeding season

Vegetation structure, including absolute densities and foliage volumes were measured on all study plots using the point quarter methods (Cottom and Curtis 1956) and analyzed using the procedures described by Szaro and Balda (1979). Originally eleven different variables were calculated but only seven were included in the model building procedures. These variations were: 1. Total foliage volume for all strata; 2. Sapling volume; 3. Trunk volume; 4. Total oak foliage volume; 5. Oak importance value; 6. Snag density; 7. Absolute density of all trees.

The regression analysis began with an examination of data from eight study plots during the six years. The BMDP statistical package (Dixon and Brown 1979) was used to identify the best set of regression equations for explaining the variability in densities of secondary cavity nesters. The equations in the best set differed by very small amounts in their R-square values but each contained a different combination of independent variables that could be used to predict bird densities.

Information gathered in 1979 and 1980 (table 1), on three study plots subsequent to initial regression analysis, was used as a test of the predictive validity of the models. Using the regression model from the initial analysis, confidence intervals at the new values of vegetative and climatic factors from 1979 and 1980 were calculated (Draper and Smith 1966). The actual densities of the birds observed during the test census were then compared with the predicted densities and confidence intervals. The best model was considered that one which explained a large amount of the variability in bird densities from 1973-1978, and also predicted well the subsequent densities observed in later years. The SPSS statistical package (Hull and Nie 1981) was used to examine the residuals of the best model.

In northern Arizona's ponderosa pine, secondary cavity nesters make up between 40 and 55% of the entire breeding bird community, and about 33% of the breeding species. As snag densities decline, there is a concomitant decline in the proportion of the total breeding bird community contributed by secondary cavity nesters but not a noticeable decline in breeding species (Balda 1975, Cunningham et al. 1980).

Cunningham et al. (1980) found a significant positive regression model for secondary cavity nesters (as a group) in ponderosa pine forests. Their regression model used three vegetation variables: snag density; non-ponderosa pine foliage volume; ponderosa pine foliage volume. For the same eight areas used in this analysis, 76% of the variability in bird densities were explained by these three independent variables and snag density explained more than half of this variability. They were, however, not able to obtain statistically significant models for the individual species. Snag densities varied from 4 to 208 on the eight plots. Birds preferred tall snags with diameters of 50 to 90 cm. Of the five common secondary cavity nesters, four (Violet-green Swallow



Table 3.--Multiple regression model for Violet-green Swallow and results of testing the model.

$Density = 4.22 - 3.14(DISPL) + 0.06(SNAG) + 0.004(FVTOT)$		
Observed	Predicted	W/In Confid. Interval?
17.50	10.51	Yes
5.00	9.23	Yes
7.50	5.12	Yes
2.50	3.84	Yes
0.00	-7.34	Yes
0.00	-4.36	Yes

$R^2=0.89$   
 $p < 0.0001$

*Tachycineta thalassina*, Pygmy Nuthatch *Sitta pygmaea*, Western Bluebird *Sialia mexicana* and Mountain Chickadee *Parus gambeli*) placed the majority of their nests in snags whereas the White-breasted Nuthatch *Sitta carolinensis* placed most of its nests in live trees.

In order of increasing sensitivity the common breeding secondary cavity nesters fall into four groups. The White-breasted Nuthatch places most of its nests in live trees and is, therefore, insensitive to snag removal. At low snag densities Western Bluebirds are known to utilize live oaks. Mountain Chickadees and Pygmy Nuthatches track snag density closely but will switch to other nest sites at low snag densities. The most sensitive species is the Violet-green Swallow which nests only in snags (Cunningham et al. 1980). Obviously, we can predict that the more sensitive a species is to snag density the better the model will be if snag density was properly assessed.

## RESULTS

### Violet-green Swallow

This species is a summer resident and arrives in the ponderosa pine forest in early April. Through the course of this study its density varied from zero to 45 pairs per 40 ha reaching highest densities on plots least disturbed by timber removal. Where snags are clumped this species has a tendency to be colonial. This species is an aerial feeder and obtains insects on the wing. It often uses snags for perch sites.

The selected multiple regression model contained one weather and two vegetation variables. Low mean temperature during dispersal, snag density, and total foliage volume combined to explain 89% of the variability in the year to year fluctuation in breeding populations. Densities from all six plot-years used to test the model fell within the confidence intervals (table 3).

### Pygmy Nuthatch

This permanent resident species is one of the most common and widespread breeding species in the ponderosa pine forest. Through the course of this study, this species had densities ranging from one to 42 pairs per 40 ha, reaching highest densities on undisturbed plots. This species often has more than two birds attending nestling young. It also roosts communally in fall, winter, and spring, in cavities in snags. It obtains the majority of its insects by gleaning them from nettle clusters.

The selected multiple regression model contained three habitat variables, all indicative of old growth forest. Total foliage volume, trunk volume, and snag density combined explained 85% of the variation in population density. This model correctly predicted this species density in all six plot-years (table 4).

### Mountain Chickadee

This insectivorous, permanent resident species is typical of ponderosa pine and mixed coniferous

Table 4.--Multiple regression model of Pygmy Nuthatch and results of testing the model.

$Density = 8.78 + 0.0004(FVTOT) - 0.82(TRNK) + 0.10(SNAG)$		
Observed	Predicted	W/In Confid. Interval?
23.70	15.78	Yes
15.00	15.78	Yes
17.50	12.38	Yes
22.50	12.38	Yes
8.70	-0.87	Yes
0.00	-0.87	Yes

$R^2=0.85$   
 $p < 0.0001$

Table 5.--Multiple regression model for Mountain Chickadee and results of testing the model.

Density = 24.07 + 0.06(SNAG) - 0.81(TRNK) - 0.28(IVOAK)		
Observed	Predicted	W/In Confid. Interval?
5.00	6.31	Yes
0.00	6.31	Yes
7.50	7.08	Yes
1.20	7.08	Yes
0.00	-0.35	Yes
0.00	-0.35	Yes

R<sup>2</sup>=0.77  
p < 0.0001

forest. Its density ranged from one to 26 pairs per 40 ha during this study. The bird forages by gleaning insects from nettles, twigs, and small branches. This species becomes very secretive during the breeding season.

The three variables that contributed to the statistically significant multiple regression model were snag density, trunk volume, and importance value of oak. These variables accounted for 77% of the variation in breeding density of this species. This model correctly predicted chickadee density in each of six years (table 5).

#### Western Bluebird

This summer resident, insectivorous species arrives in the ponderosa pine forest before snow melt occurs. In mild winters it may spend its time in the pine forest, roosting in cavities. This species feeds on insects that it hawks off or near the ground. During this study bluebird densities varied from five to 26 pairs.

The significant multiple regression model contained one weather and two habitat variables. Surprisingly, winter mean high temperatures were positively correlated with summer breeding density. Snag density and trunk volume were the two habitat variables in the selected model. Together, these three variables explain 71% of the fluctuation in breeding bird density for this species. Five of six test sets of data fell within the confidence interval (table 6).

Table 6.--Multiple regression model for Western Bluebird and results of testing the model.

Density = 5.80 + 2.5(WINH) + 0.07(SNAG) - 1.14(TRNK)		
Observed	Predicted	W/In Confid. Interval?
0.00	2.46	Yes
0.00	9.00	Yes
10.00	4.44	Yes
10.00	10.98	Yes
15.20	0.60	No
11.00	5.60	Yes

R<sup>2</sup>=0.71  
p < 0.0001

#### White-breasted Nuthatch

This permanent resident secondary cavity nester prefers to nest in cavities in live pines and oaks. This catholic species occurs in most forests and woodlands in the U.S. It is a trunk and branch gleaner. During this study this nuthatch varied in density far less than the four above-mentioned species, varying only between six and 12 pairs per 40 ha.

The selected model for the White-breasted Nuthatch explained only 50% of the fluctuation in breeding population and contained only weather variables. These were: precipitation in the form of snow during dispersal; mean low temperature during dispersal; mean high temperature during dispersal. These latter two variables had significant changes indicating low temperature had a negative affect and high temperature a positive one on breeding bird density the next year. All six years used to test the model fell within the confidence interval (table 7).

#### Total Secondary Cavity Nesters

If suitable cavities remain at the same level between years and interspecific interference competition is occurring, then total population density of the secondary cavity nesters should remain stable between years. This will occur because of reciprocal density changes. For every increase by one species there should be a corresponding decrease by one or more of the other species. Use



Table 7.--Multiple regression model for White-breasted Nuthatch and results of the model.

Density = 11.33 + 1.09(DISPS) - 0.63(DISPL) + 0.95(DISPH)		
Observed	Predicted	W/In Confid. Interval?
10.00	5.74	Yes
6.20	7.48	Yes
10.00	5.74	Yes
10.00	7.48	Yes
4.30	7.09	Yes
3.20	5.38	Yes

R<sup>2</sup>=0.50  
p < 0.0076

of partial correlation coefficients between all possible subsets of the species revealed, however, that such was not the case (Balda and Gaud MS), in fact most correlation coefficients were positive. This indicates that most, if not all species increase or decrease independently of one another.

Because of this finding, we felt justified in attempting to construct a model for the total density of secondary cavity nesters. The statistically significant model we chose contained three habitat variables: trunk volume, importance value of oak, and snag density, and these three explained 85% of the variability in total breeding bird density. When testing this model all six plot-years fell within the confidence interval (table 8).

#### DISCUSSION

Snags have most likely been a conspicuous and stable component of the ponderosa pine forest for thousands of years because they result from natural processes such as senility, wind, fire, insect damage, and lightning. It is, therefore, predictable that some animals would come to rely on them for their survival and reproduction. One such specialized group is the secondary cavity nesters, which have come to rely on standing, dead trees that have accumulated woodpecker holes and lightning strikes, through time, for nesting and roosting sites. This reliance has been negated because old, standing, dead trees have not been properly placed in management schemes and plans. In fact, snags have been persecuted for so many years, it

is difficult to get a realistic assessment of their role in managed forests. Snag removal policies plus fire suppression practices have left us little to work with in modern times. We have few, if any, natural or control areas to use as standards for comparison. Thus, our data, and the conclusions we draw from them may be suspect. Yet, it is better to provide the manager with the best information available than to provide no information.

Comparing across species, a total of 18 variables could have had significant predictive value in the multiple regression models described above. Yet, only four of seven habitat variables and four of 11 independent weather variables were entered in models that gave the highest predictive accuracy. All eight variables entered into the multiple regression models with the same sign regardless of the species specific model. Thus, this taxonomically diverse group of species may be limited by the same, or similar, environmental variables. Vegetation variables made significant contributions to the models in 13 of 18 possible cases and weather variables made significant contributions in the remaining five instances.

The species that used snags least for nest sites, the White-breasted Nuthatch, was unique in that all variables in the statistically significant model were climatic ones and two were unique to the species. Why autumn snow combined with high autumn temperatures should have a positive impact on next years breeding population of White-breasted Nuthatches is not immediately obvious but fall insect populations may respond positively

Table 8.--Multiple regression model for total density of secondary cavity nesters and results of testing the model.

Density = 157.07 - 4.25(TRNK) - 1.65(IVOAK) + 0.27(SNAG)		
Observed	Predicted	W/In Confid. Interval?
56.20	54.27	Yes
26.20	54.27	Yes
52.50	59.64	Yes
46.20	59.64	Yes
28.20	19.78	Yes
14.20	19.78	Yes

R<sup>2</sup>=0.85  
p < 0.0001



to warm, wet snow. This may have a beneficial affect on the survivorship of young and/or adult White-breasted Nuthatches. Also, it is of interest to note that the species least sensitive to declines in snag densities had all weather related variables in the most predictive model, and these variables could account for the least variance for any of the five species.

Violet-green Swallow populations were also influenced by weather, specifically, mean low temperatures during the fall dispersal period. Low autumn temperatures may cause a precipitous drop in flying insects. The lack of food during fall and early winter is known to be particularly devastating to young birds of the year (Lack 1954) and this heavy mortality may affect population size the next year.

The multiple regression model for the Western Bluebird contains an interesting weather factor, mean high temperature during the winter, which had a positive affect on density. Two possible explanations are immediately obvious but remain speculative. First, high temperatures in winter may be conducive to ground insects as survival of pupae may be better in mild winters. Thus, food supply for bluebirds may be higher in spring. Also, ground insects may hatch out earlier after mild winters. A second explanation is more direct, as in mild winters some bluebirds may spend the winter in the pine forests. These birds may gain priority rights to certain nest sites and spring returning birds may then take less suitable sites, especially if insect densities are high.

Vegetation variables were far more prevalent in the models than weather variables, with snags appearing in five of six models. Thus, this variable is the single most important factor in determining density of most of the secondary cavity nesters. Because White-breasted Nuthatches do not prefer snags for nest sites it is not surprising this variable did not appear in its model.

In addition to snag density, total foliage volume appeared twice, and in both models (Pygmy Nuthatch, Violet-green Swallow) it was positively correlated with bird density. Foliage volume was also important in the preliminary models constructed by Cunningham et al. (1980). Earlier, Balda (1969) found pine foliage volume to be limiting for Pygmy Nuthatches in pine forests in southeastern Arizona.

The other two variables, trunk volume and importance value (relative density + relative frequency + relative dominance) of oak appeared in models five times. These two consistently had a negative influence on population size.

Trunk volume had a simple correlation of 0.51 with total foliage volume, yet entered the regression models with the opposite sign from foliage volume. It appears that secondary cavity nesters prefer a situation where foliage volume is high but trunk volume is low. This situation would occur in forests in which old "yellow pines" were relatively sparsely and well spaced, and trees of

intermediate age were common. Thus, heterogeneous stands seem to be favored over homogeneous ones. Szaro and Balda (1979) found bird populations to be lower in a stand that had not been cut for 60 years than in stands that had received moderate silvicultural treatment. It would appear then, that foliage volume associated with old "yellow pines" is not as productive in terms of providing resources to the secondary cavity nesters as is the foliage of more intermediate-aged trees. Yet, it is the older trees that eventually become snags.

It is possible that in this case the birds are telling us something about the primeval state of the ponderosa pine forest? One scenario proposed by Cooper (1960) stated that large stands of ponderosa pine forests were of even age due to the effects of wild fire, i.e. old senescent forests eventually burned down to be replaced by young, even-aged trees. Young seedlings are fire resistant and can withstand the cool fires that burn through these stands. If such was the case, then secondary cavity nesters would have been limited to the edges between old senescent forests and middle-aged vigorous ones, each distinctly separate in their distribution. In many regards, however, these species do not respond as ecotone or edge species but more like forest interior ones. Thus, we suggest the ponderosa pine forest was heterogeneous, in regards to age of stand, in the primeval state, with snags scattered throughout the forest.

The role of oaks, primarily Gambel's oak, remains as an enigma. In two cases the importance value of oak appeared as having a negative influence on the population of secondary cavity nesters. This influence may either be a direct or indirect one. In fact, for White-breasted Nuthatches the simple correlation should be a positive one because this species is known to nest in oaks. Such is not the case as this correlation coefficient has no statistically significant influence on White-breasted Nuthatch breeding bird densities.

Importance value of oak, however, may indicate site quality for ponderosa pine as the simple correlation coefficient between this variable and total foliage volume was -0.81. Thus, where oaks are prevalent ponderosa pine may be restricted in growth and vigor.

As predicted, the models that explained the most variance in population size were generated for the species most sensitive to a change in snag numbers. The model for the Violet-green Swallow (most sensitive) explained 89% of the fluctuation in population size whereas the model for the White-breasted Nuthatch (least sensitive) explained only 50% of this variance. The intermediate species were arranged as predicted.

#### MANAGEMENT IMPLICATIONS

1. Snag management must be integrated into an overall management plan for the ponderosa pine forests that includes some measure of foliage volume that can supply other resources such as



thermal cover, predator cover, and food resources.

2. Heterogeneous stands containing a mixture of old "yellow pines" and vigorous trees of intermediate age appear to be the ideal habitat for this select group of species.

3. Densities of secondary cavity nesters will be influenced by weather as well as vegetation characteristics of the forest. However, stand quality and vigor may mediate some weather conditions and make areas more hospitable to the birds.

#### LITERATURE CITED

- Balda, Russell P. 1969. Foliage use by birds of the oak-juniper woodland and ponderosa pine forest in southeastern Arizona, *Condor* 71:399-412.
- Balda, Russell P. 1975. The relationship of secondary cavity nesters to snag densities in western coniferous forests. USDA Forest Service Wildlife Habitat Technical Bulletin 1, 27 p. Southwestern Region, Albuquerque, N. Mex.
- Cooper, C. F. 1960. Changes in vegetation, structure, and growth of southwestern pine forest since white settlement. *Ecol. Monogr.* 30:129-164.
- Cottom, C., and J. T. Curtis. 1956. The use of distance measures in phytosociological sampling. *Ecology* 37:451-460.
- Cunningham, James B., Russell P. Balda, and William S. Gaud. 1980. Selection and use of snags by secondary cavity nesting birds of the ponderosa pine forest. PM-22, 15 p. Rocky Mountain Forest and Range Experimental Station, Fort Collins, Colo.
- Dixon, W. J., and M. B. Brown. 1979. BMDP-79: Biomedical computer programs P-series. University of California Press. Berkeley.
- Draper, N. R., and H. Smith. 1966. Applied regression analysis. John Wiley & Sons, NY.
- Fretwell, Stephan D. 1972. Populations in a seasonal environment. 217 p. Princeton Univ. Press, Princeton.
- Haartman, Lars Von. 1957. Adaptation in hole nesting birds. *Evolution* 1:339-347.
- Hull, C. H., and N. H. Nie. 1981. SPSS update 7-9: New procedures and facilities for releases 7-9. McGraw-Hill Book Co., NY.
- Karr, James R. 1980. Geographic variation in the avifaunas of tropical forest undergrowth. *Auk* 97:283-298.
- Lack, David. 1954. The natural regulation of animal numbers. 343 p. Oxford University Press, London.
- Szara, Robert C., and Russell P. Balda. 1979. Bird community dynamics in a ponderosa pine forest. *Studies in Avian Biol.* 3:1-66.
- Zeleny, Lawrence. 1972. Can we save the bluebird? *Living Wilderness* 36:24-31.

# Challenges of Snag Management<sup>1</sup>

Gregory A. Goodwin<sup>2</sup>  
and  
Russell P. Balda<sup>3</sup>

---

Abstract. -- Snags provide needed resources for 85 species of North American birds, numerous plants, invertebrates, reptiles, amphibians and mammals. Snag habitat research and management needs can be broken down into six general categories: 1) establishing realistic economic values for nongame wildlife and habitat improvements; 2) finding answers to questions raised by the National Forest Management Act; 3) understanding the role of snag-dependent birds and mammals in forest ecosystems; 4) developing methods to create snag habitat and improve snag habitat for selected species; 5) learning to integrate snag management and fuelwood management; 6) pursuing intensive public information and law enforcement programs. These areas of study are needed to provide managers with information for making management decisions.

---

## INTRODUCTION

Snags provide needed resources for 85 species of North American birds, (Scott et al. 1977) numerous plants, invertebrates, reptiles, amphibians, and mammals. It is generally assumed and supported by empirical findings that a direct relationship exists between the number of snags present and population levels of snag-dependent wildlife species occupying an area. Many species of snag-dependent birds have declined because of habitat reduction. The ivory-billed and redcockaded woodpeckers are currently on the endangered list. The wood duck now depends heavily on artificial nest boxes for its continued survival. European forests, which are intensively managed, support no snags, and consequently artificial means must be used to sustain many species of wildlife.

Each forest community supports a distinct group of snag-dependent wildlife species which have evolved through time to fill a particular role in the ecosystem. Each wildlife species has distinct requirements for diameter, age, height, and species of snag it uses. This

selection has adaptive value for each species in terms of survival and reproduction, yet in many cases we may not be able to determine these requirements because management practices have already removed the optimum, and species may be existing under suboptimal conditions.

In many forested areas, past management activities have reduced and even eliminated the potential of forests to produce and retain snags. Dead and dying trees which would have become snags were routinely removed during sanitation cuts. Existing snags were removed for safety reasons and for many years were methodically cut down as fire hazards. Shorter rotation intervals have eliminated older stands resulting in a reduced potential to produce large diameter snags.

Only during the past 10 years have land managers begun to recognize snag management problems and the inherent values of snags. Research conducted on snag dynamics and habitat requirements of snag-dependent wildlife has contributed to the implementation of snag management policies by Federal land management agencies. However, this is only the beginning of management of the snag resource. Six general categories of research and management needs are necessary to provide resource managers with the kind of information necessary for making wise snag management decisions.

## ECONOMIC VALUES

As managers and researchers, we are still concerned about establishing, and more importantly,

---

<sup>1</sup>Paper presented at the Snag Habitat Management Symposium, Flagstaff, Arizona. June 7-9, 1983.

<sup>2</sup>Wildlife Biologist, USDA Forest Service, Coconino National Forest, 2323 East Greenlaw Lane, Flagstaff, Arizona 86001.

<sup>3</sup>Professor of Biology, Department of Biological Sciences, Northern Arizona University, Flagstaff, Arizona 86011.



communicating realistic economic values for wildlife, especially nongame wildlife. Most people will agree that wildlife outputs of the typical forest possess value, but great differences of opinion arise as to the relative amounts of such values. Some approaches to evaluate wildlife values have been made, yet a large measure of intangibility always surrounds many of these values (Clawson 1975). This puts managers at a decided disadvantage because other forest resources have easily defined and measured economic values. Measuring wildlife outputs, assigning those outputs a value, and communicating those values to decision makers are major problems facing many agencies. A process is also needed to assign values to habitat improvement work done for wildlife. This type of information will facilitate management decisions, especially where there are conflicts between wildlife and other resources. This approach may not be the best way to compare wildlife with other resources because of the subjective nature of assigning dollar amounts to most wildlife. A better approach may be to start with the basic premise that all species are integral to ecosystem functions. Using recreation cash values, as most agencies do, ignores that wildlife enhances the quality of human life. It also ignores the biological value wildlife has as part of an integrated ecosystem. Recreational uses of wildlife are easily defined but difficult to measure.

#### NATIONAL FOREST MANAGEMENT ACT

The National Forest Management Act of 1976 poses several questions concerning wildlife that must be dealt with in Forest Service land management plans. Answers must be found for questions such as: what are the best indicator species for snags in different forest types; what are the minimum habitat needs for snag-dependent wildlife species; how can snag habitat be provided over time in conjunction with intensive timber management; how should snags be distributed; how should snag-dependent wildlife be monitored and what are stable densities for snag-dependent species. The requirements of this Act present substantial management problems and provide major challenges for research.

#### ROLES OF SNAG-DEPENDENT WILDLIFE

The role of insectivorous, snag-dependent birds in forest ecosystems is a major question that has received some attention by researchers. Of particular interest is understanding the relationship of snag-dependent birds to insect population dynamics. Many early works tended to overstate the case and used simplistic interpretations of birds controlling insect populations (Thomas 1979). Definitive data is needed to illustrate the role that snag-dependent birds and insectivorous bats play in holding insect populations at endemic levels or exerting some control during early stages of outbreaks.

Understanding this relationship will help give economic consideration to the basic functional characteristics of the ecosystem in the decision making process of land management agencies. Since snag-dependent birds and mammals make up a large proportion of the insectivorous, forest dwelling wildlife population, it is important to adequately reflect the relationship to insect populations with realistic economic and biologic values.

#### CREATING AND IMPROVING SNAG HABITAT

Cost effective methods for creating snag habitat and/or improving habitat for selected snag dependent species are becoming increasingly important. In the past, managers have been concerned only with preserving existing snags. Finding ways to improve habitat for various wildlife species or groups of species and how to create snag habitat from live trees present research and management with important challenges. Answers to these questions will provide valuable management tools.

We may be faced with providing artificial resources such as nest boxes, as a result of continuing habitat reduction from increasing demand for wood products. This alternative may not be the most appealing, however, it may be our only recourse near urban areas or other areas heavily impacted by timber salvage operations or fuelwood use. While nest boxes may be a valuable management tool for some problems or problem areas, boxes cannot be considered a total substitute for snags. But the use of artificial nesting structures is certainly deserving of additional research. We need the baseline data now so applications can be made when critical situations arise.

Meeting snag requirements over time is a critical question facing resource managers today. As timber management intensifies, there is a tendency to eliminate large trees that could become snags. In addition, existing snags will be lost through natural processes, and fuelwood activities. This will reduce snag recruitment and result in substantial reductions in snag densities. We need management, policies and practices that will ensure a sufficient number of quality snags to provide for long-term survival and reproduction of snag-dependent wildlife species. A major challenge facing all of us is to get consideration for wildlife habitat firmly ingrained into timber planning and management.

#### ENERGY DEMANDS

The increasing demand for fuelwood poses a particular threat to snag-dependent wildlife species. Wood is becoming increasingly attractive as an alternative energy source as the cost of home heating increases. Fuelwood demand is increasing as populations increase. This is already presenting critical management problems in some areas due to illegal fuelwood harvesting. Fuelwood harvest was largely concentrated around urban areas in the past but with increased demand,



harvesting has increased in distant less accessible areas. The projected increases in fuelwood demand present a challenge that we must meet while still providing habitat for snag-dependent wildlife species.

Land managers must begin to carefully analyze fuelwood harvest alternatives based on a clear understanding of the impacts on wildlife and the long-term impacts on the forest. Snag management and fuelwood management must be integrated into timber management programs if we are to ensure proper management of these two resources.

## PUBLIC EDUCATION

Illegal fuelwood harvest is a major management problem in many areas. Most people think snags have no biological value. They can see only the value of the wood for burning in fireplaces and woodstoves. We as researchers and managers must convey to the public, including private landowners, the importance of snags to wildlife and to forested lands. We must change public attitudes toward snag management. Although changing public attitudes through the educational process is slow, its pursuit is none-the-less important because historically good forest management meant removing snags. This is an important challenge that we must pursue aggressively.

Smokey the Bear has been an extremely effective public education tool in Forest Service fire prevention programs. Perhaps the Forest Service should add a third mascot to its public education team of Smokey and Woodsy Owl. What better candidate for the job than a nationally recognized figure like Woody Woodpecker?

Public education is a difficult process made even more difficult by the fact that, before completing high school, most of our personal traits have already been formed (Hamilton 1982). There is ample evidence that our education system has thus far failed to develop a conservation ethic or understanding (Hobart 1972). We must make wildlife and other natural resource subjects a part of the K-12 curriculum. Natural resource material is being developed and used in some states (Hamilton 1982). We need to take a more active role in dissemination of this material. Long-range education programs must build solid foundations for understanding resource management. An awareness by the public of man's dependence upon, and responsibility for, natural ecosystems and an understanding of the values of wildlife are critical to long-term resource management and conservation. Conservation education must build an ethical underpinning for land economics and a universal curiosity to understand the land mechanism. Conservation may then follow (Leopold 1953).

Biologists too need to be better educated in ecosystem management. Most biologists are well-versed in the biological details of animals,

and usually in depth only about a species or small group of animals. But we often lack knowledge of habitat requirements related to populations of wildlife (Cutler 1982) and the role these populations play in an integrated ecosystem.

Along with public education goes an increased need for enacting and enforcing of fuelwood laws. Law enforcement is a basic management tool. However, it has, in many ways, been neglected in forest management by land management agencies. We need to recognize fuelwood law enforcement problems and take appropriate action to allocate money and people to carry out enforcement programs. History has repeatedly shown us that public morality and ethics cannot be legislated. However, enacting realistic state fuelwood laws, establishing uniform fuelwood policies, and strong enforcement of fuelwood laws is critical to the continued existence of snags on many acres of forested lands. Open and continuous communications between enforcement and management agencies, and research agencies will contribute significantly to our ultimate success.

## CONCLUSIONS

In many forested areas, timber management, fuelwood activities, and fire prevention and suppression activities are making snags a persecuted and endangered wildlife habitat.

"The vulnerability of snags makes snag-dependent wildlife equally vulnerable. If snag-dependent wildlife species are to remain as part of the managed forest, forest managers must provide the necessary habitat." (Thomas 1979)

Although there are differences in detail, most of us can agree on a number of basic principles of snag management.

1. Manage for the total ecosystem of which snags are an integral part.
2. Through research, establish a basic understanding of the ecological, social and economic aspects, not only of snag-dependent wildlife, but of all wildlife.
3. As professional resource managers and researchers work towards establishment of conservation and resource education programs.
4. Make wildlife policy decisions based on public interest and sound ecological principles, not just on special interests.
5. And finally, "spare that old dead tree," or, "what we need around here is a little more dead wood."



## LITERATURE CITED

- Clawson, Marion. 1975. Forests for Whom and What For? The John Hopkins University Press, Baltimore, MD. 175 pp.
- Cutler, M. Rupert. 1982. What Kind of Wild-lifers Will be Needed in the 1980's? Wildl. Soc. Bull. 10(1):75-79.
- Hamilton, Clifford R. 1982. Project Learning Tree and Project WILD, Resource Models for Education at the Elementary and Secondary Levels. Trans. N. Amer. Wildl. and Natur. Resour. Conf. 47:248-251.
- Hobart, W. 1972. What's Wrong With Conservation Education?. J. Environ. Ed. 3(4):23-25.
- Leopold, Aldo and Luna Leopold. 1953. Round River: From the Journals of Aldo Leopold. Oxford Univ. Press, Inc., N.Y. 173 pp.
- Scott, Virgil E, Keith E. Evans, David R. Patton and Charles P. Stone. 1977. Cavity-Nesting Birds of North American Forests. U.S. Department of Agriculture Handbook, 511, 112 p. Washington D.C.
- Thomas, Jack Ward, ed. 1979. Wildlife Habitats in Managed Forests, the Blue Mountains of Oregon and Washington. U.S. Department of Agriculture Handbook 553, 512 p. Washington D.C.



Davis, Jerry W., Gregory A. Goodwin, and Richard A. Ockenfels, tech. coords. 1983. Snag habitat management: proceedings of the symposium. USDA Forest Service General Technical Report RM-99, 226 p. Rocky Mountain Forest and Range Experiment Station, Fort Collins, Colo.

These proceedings include 41 papers focusing attention on the need to integrate management of snags -- dead or deteriorating trees critical to needs of cavity-dependent wildlife -- with other resource uses and demands. Sessions concentrated on management, habitat and species requirements, and monitoring and modeling.

Keywords: Snags, wildlife habitat, forest management

Davis, Jerry W., Gregory A. Goodwin, and Richard A. Ockenfels, tech. coords. 1983. Snag habitat management: proceedings of the symposium. USDA Forest Service General Technical Report RM-99, 226 p. Rocky Mountain Forest and Range Experiment Station, Fort Collins, Colo.

These proceedings include 41 papers focusing attention on the need to integrate management of snags -- dead or deteriorating trees critical to needs of cavity-dependent wildlife -- with other resource uses and demands. Sessions concentrated on management, habitat and species requirements, and monitoring and modeling.

Keywords: Snags, wildlife habitat, forest management

Davis, Jerry W., Gregory A. Goodwin, and Richard A. Ockenfels, tech. coords. 1983. Snag habitat management: proceedings of the symposium. USDA Forest Service General Technical Report RM-99, 226 p. Rocky Mountain Forest and Range Experiment Station, Fort Collins, Colo.

These proceedings include 41 papers focusing attention on the need to integrate management of snags -- dead or deteriorating trees critical to needs of cavity-dependent wildlife -- with other resource uses and demands. Sessions concentrated on management, habitat and species requirements, and monitoring and modeling.

Keywords: Snags, wildlife habitat, forest management

Davis, Jerry W., Gregory A. Goodwin, and Richard A. Ockenfels, tech. coords. 1983. Snag habitat management: proceedings of the symposium. USDA Forest Service General Technical Report RM-99, 226 p. Rocky Mountain Forest and Range Experiment Station, Fort Collins, Colo.

These proceedings include 41 papers focusing attention on the need to integrate management of snags -- dead or deteriorating trees critical to needs of cavity-dependent wildlife -- with other resource uses and demands. Sessions concentrated on management, habitat and species requirements, and monitoring and modeling.

Keywords: Snags, wildlife habitat, forest management



