

ALBERT R MANN
LIBRARY

NEW YORK STATE COLLEGES
OF
AGRICULTURE AND HOME ECONOMICS

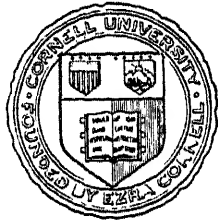

AT

CORNELL UNIVERSITY

The
Encyclopedia of Practical
Horticulture

PRESS OF
LOWMAN & HANFORD Co
SEATTLE

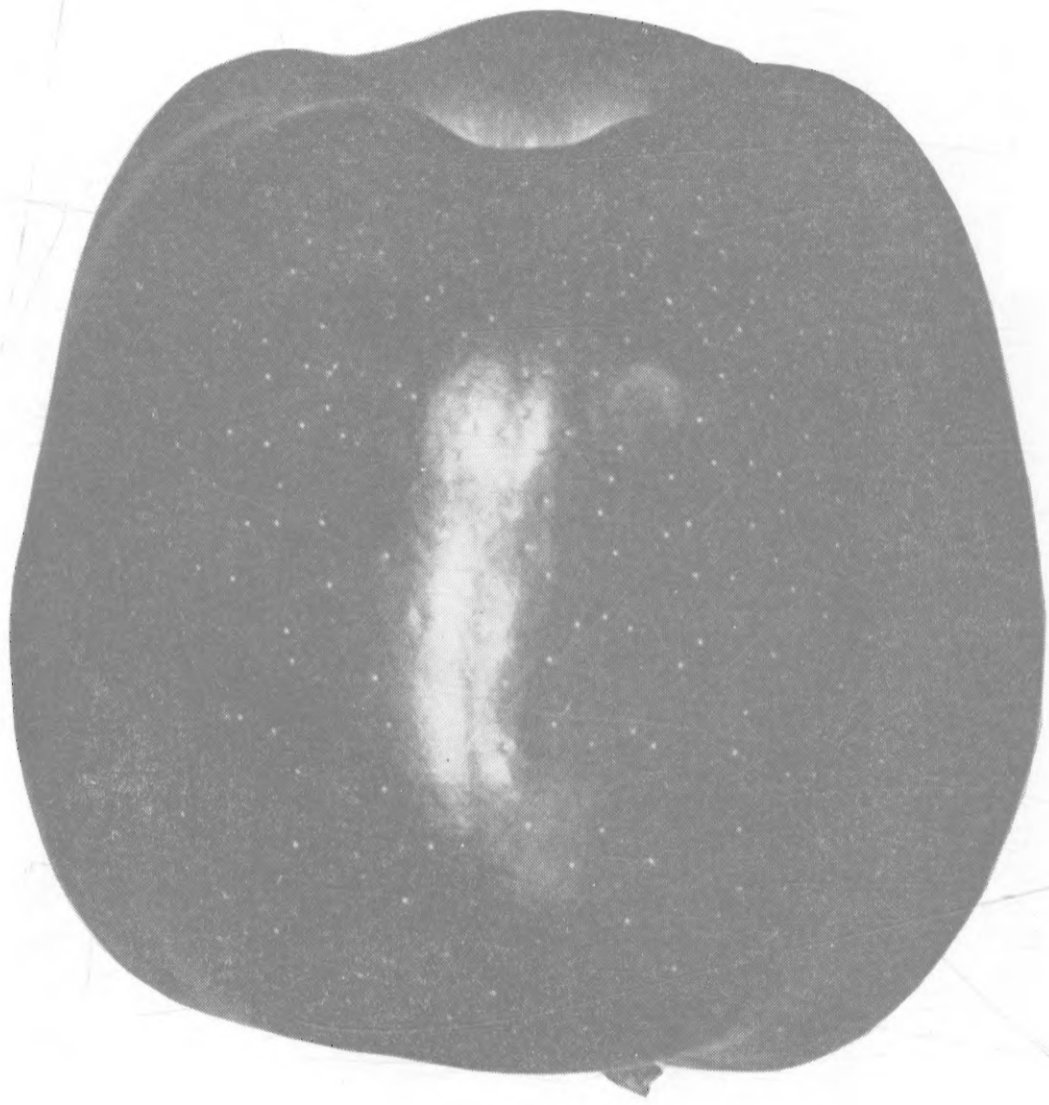

Delicious

(See p. 209)

The
Encyclopedia of Practical
Horticulture

A Reference System of Commercial
Horticulture

Covering the Practical and Scientific
Phases of Horticulture with Special
Reference to Fruits and Vegetables

Editor-in-Chief
GRANVILLE LOWTHER

Associate Editor
WILLIAM WORTHINGTON

Assisted by the best known scientific and practical horticulturists
throughout the country, and particularly in the Northwest .

Illustrated

Volume I

PUBLISHED BY
THE ENCYCLOPEDIA OF HORTICULTURE CORPORATION
W M FLEMING President
NORTH YAKIMA WASHINGTON, U S A

Copyright 1914 by
ENCYCLOPEDIA OF HORTICULTURE
CORPORATION

PREFACE

In launching the *ENCYCLOPEDIA OF PRACTICAL HORTICULTURE*, we offer, as justification for our course, the following reasons:

First—We are living in the midst of one of the best fruit districts of the world and have learned from practical experience what the fruit grower needs. We have worked in the orchards and studied the varied conditions from the viewpoint of the practical fruit grower.

Second—Our fruits, especially our apples, command the highest prices in the markets of the world. This fact is not dependent alone upon the physical conditions under which our fruits are produced, but also upon the methods applied in growing them and preparing them for the market.

Third—We have visited all the principal fruit growing sections of the United States and parts of Canada with a view to studying the best conditions and the best methods for the production of the various kinds of fruits.

Fourth—We have consulted with many of the most prominent horticulturists, both in the schools and in the fields of practical work, and have obtained what information we could from all available sources.

Fifth—We have consulted the literature that seems to us best adapted to our needs, and have quoted from the ablest writers on the various subjects, giving to each and every one due credit.

Sixth—We have embodied in this work articles from the ablest contributors and specialists on the particular subjects treated. We have endeavored to bring everything up to date and to condense into three volumes that which we believe would be of the most practical benefit to the fruit grower.

We have tried not to be technical. At the same time we believe we have been scientific, in that we have aimed to make all of our teachings conform to the facts as scientists have discovered them. Where it was possible to do so, we have expressed these facts in plain and untechnical language. Believing that thousands of fruit growers in this country, who are too busy to gather all this information for themselves, will be interested and profited by such a work, and believing that thousands who live in other parts of the United States will be interested in knowing the methods we employ for the production of fruits, proven by the prices they command to be among the best, we submit this work to the world.

GRANVILLE LOWTHER

INTRODUCTION

THE NEED FOR AN ENCYCLOPEDIA OF PRACTICAL HORTICULTURE

Fruit growers throughout the country and the Northwest in particular have been aware of the fact that there has come into existence during the past twenty-five years a vast quantity of information on the subject which most vitally interests them, knowledge which in some sections was transforming the whole industry. These same men were also aware that this information was in a form which was wholly inaccessible to the busy man.

In addition there was a growing demand for a reference work suitable for the use of the public schools in connection with agricultural courses.

It was these facts which made the necessity for a compilation of the best in practical horticulture apparent and some attempt to meet the need inevitable. This was the origin of the idea of the ENCYCLOPEDIA OF PRACTICAL HORTICULTURE.

THE UNDERTAKING

It took more than three years of hard work on the part of the editors and management to organize the forces and marshal the facts which have made this pioneer work the best and only thing in its field. There have been gathered into handy form facts which it would take a lifetime of the busy fruit grower to collect and arrange for himself. The saving to the man who wants the information has been immense.

The undertaking has been financed by the fruit growers of the Northwest who have seen the necessity for such a compilation and the value of having the work done in the Northwest. The labor of securing this cooperation has rested almost wholly upon the shoulders of Mr. W. M. Fleming.

SOURCES OF INFORMATION

In general there are two sources of information available for a work of this kind. They are:

1. Materials already published.
2. Knowledge stored in the minds of practical and scientific men, but not yet reduced to writing.

The main sources for the first are the publications of the U. S. Department of Agriculture in its many bureaus, the various State Experiment Stations and private publications devoted to particular interests.

The Government and Experiment Station reports are largely technical, often voluminous, detached, and to the average man, inaccessible as though buried under the pyramids. This vast storehouse of information has been opened, the unadaptable material thrown out and that which is of permanent value retained.

As for the second source of information, every fruit district in the Northwest has been visited and the co-operation of leading horticulturists secured. Thousands of letters have been written to all parts of the country to secure first hand knowledge from those known to possess valued experience. The principal fruit districts of the United States have been revisited by the Editor in Chief.

THE PLAN

The plan is to set forth in their natural order all the steps and processes necessary for the propagation, maturing in their highest perfection, harvesting and marketing of all the commercial fruits and vegetables, with all the information necessary for the selection of proper seeds or stocks, site, soil and climate, the kind of preparation to make and care to give, the sort of cultivation, fertilization and pest prevention to provide for and costs of production. All processes are fully illustrated with seven hundred and fifty drawings and photos.

In addition there is provided such information on the history and the origin of the various fruits and plants, their physiology and hereditary tendencies and environmental requirements, as shall enable the reader to understand any special problems which may arise.

Descriptions of the various fruit districts of the United States and their peculiar adaptations are given, together with the latest statistics of the industry for each district and for the whole country. Soil and climatic conditions are amply treated as well as frost data, with approximate dates to provide for and means and cost of prevention.

METHOD OF TREATMENT

All fruits and vegetables, as well as other main subjects, have been treated in regular alphabetical order. Main articles are headed in large black face type; subheads under main subject in capitals; paragraph headings in small black face type; cross references are in small capitals; further subdivisions and scientific names are in italics.

Main subjects are treated in their logical order and any one wishing to find a topic which, for example, would naturally fall under apple, need only follow the natural order of the development of the fruit from seed to market, in order to find what he wishes to know.

INDEX AND CROSS REFERENCE

For the further guidance of the reader, an index has been prepared covering over 4,500 subjects. These will be found in their regular alphabetical order in the index at the end of the third volume, and in a great many cases also under the particular main or subhead which includes it. For example, *alfalfa* is found in the index under Al and also under Apple Orchard as a part of the subtopic *Intercropping*.

Cross references in regular alphabetical order in the main body of the work are also used in cases of this kind.

DISEASES AND PESTS

These are treated usually under the most important host plant, at the end of the article on that plant. To illustrate: San Jose Scale is treated under Apple Pests at the end of the article on Apple. Or, the exact page upon which the article on San Jose Scale begins may be found by looking under Apple Pests in the index or alphabetically under its own head, San Jose Scale. Where long lists of diseases, pests, etc., have occurred, the scientific names have not been used, but where each separate disease or pest has been listed in its own alphabetical order the scientific name has been added.

CONTRIBUTORS

The contributors have been chosen with a special view not only to technical knowledge of their various specialties but also from the fact of practical experience with the actual conditions to be met by the average grower.

The editors wish to acknowledge especial indebtedness to MR. P. J. O'GARA, Pathologist and Chief in Charge of Agricultural Investigations, American Smelting and Refining Co., Salt Lake City; formerly Pathologist and Entomologist for the Rogue River valley, who has maintained a helpful interest in the project from the beginning, has lent his aid in the form of numerous contributions, and especially through an exhaustive article on the nature and control of Blight of Apples and Pears, and through valuable advice.

To MR. FRANK KINSEY for unstinted labor in the collection and preparation of the article on Apple Packing and Warehouse Management, and for numerous helpful suggestions along the line of allied subjects.

To PROFESSOR P. F. WILLIAMS, of the Mississippi Experiment Station, for valuable original contributions on the subject of Fruit and Vegetable Growing in the Gulf States.

To PROFESSORS C. I. LEWIS, H. F. WILSON, H. S. JACKSON, H. P. BARSS, A. L. LOVETT, F. C. REIMER and F. D. BAILEY of the Oregon Experiment Station, and to the Station itself for the use of matter which has appeared from time to time in the publications of the Station and which has been revised and brought down to date at no little labor for our

special use; for the loan of many valuable photographs and drawings, and of colored plates.

Also to MR. E. O. ESSIG, of the California Horticultural Commission, for similar services; and for the loan of a large number of photographs, and to other members of the Commission for similar kindness in permitting the use of practical suggestions as to the control of insect pests. Our work would be much poorer but for the generosity and helpfulness of these men.

We wish to acknowledge the kindly offices of the Directors of most of the Experiment Stations, heads of Bureaus in the Department of Agriculture and Teachers of Horticulture in the State Institutions, notably PROFESSORS O. M. MORRIS of the Washington Station, W. H. WICKS of Idaho, R. A. COOLEY of Montana, J. H. STAHL of the Western Washington Station, W. T. MACOUN of Ottawa, Canada; D. B. SWINGLE of Montana, H. A. GOSSARD of Ohio, H. GARMAN of Kentucky, as well as a long list of others, and to MR. C. C. GEORGESON of the Alaska Station.

To a large number of persons in every state who through correspondence or personal suggestion and advice have lent their aid to make this compilation possible. The names of more than 200 persons appear in this work as the authors of material worthy of note.

We wish to acknowledge the assistance of the following persons, associations and periodicals for contributions and materials along the lines of their respective specialties:

- A. C. ALLEN, Orchardist, Medford, Oregon
 DWIGHT S. ANDERSON, Spokane Bar
 H. C. ATWELL, Ex-President Oregon Horticultural Association
 FLOYD DOUGLASS BAILEY, A. B., Assistant Crop Pest Investigations, Oregon Experiment Station
 CLYDE BARNUM, Deputy Inspector Rogue River Valley
 C. N. BENNETT, Engineer Clatsop Cranberry Bogs
 MR. N. S. BENNETT, Medford, Ore.
 BETTER FRUIT.
 PHILO K. BLINN, Special Investigator Colorado Experiment Station, Superintendent The Rocky Ford Cantaloup Seed Breeders Association
 LUTHER BURBANK, Santa Rosa, Calif.
 MR. F. H. BURGLEHAUS, Sumner, Wash.
 A. B. CAPPS, Nurseryman, Prosser, Wash.
 E. K. CARNES, Superintendent State Insectary, Sacramento, California; Horticulturist Natomas Consolidated, Sacramento, California
 COUNTRY GENTLEMAN.
 A. G. CRAIG, Horticulturist Washington State College; Superintendent Arcadia Orchards Company
 JAMES DAILY, Superintendent Hillcrest Orchards, Medford, Oregon
 P. S. DARLINGTON, Horticulturist, Wenatchee, Wash.
 W. M. DAVIDSON, U. S. Department Agriculture, Bureau of Entomology
 G. B. DEAN, Orchardist, Medford, Oregon
 J. W. DUNCAN, Superintendent of Parks, Spokane, Washington
 ORANGE JUDD FARMER.
 R. W. FISHER, Horticulturist Montana Experiment Station; Superintendent Thousand Acre Ranch, Bitter Root Valley, Montana
 S. W. FOSTER, U. S. Department of Agriculture, Bureau of Entomology
 H. M. GILBERT, President and General Manager Richey & Gilbert Company, Fruit Grower, Toppenish, Wash., Large Producer of Apples
 PROFESSOR W. H. GOODWIN, Ohio Experiment Station.
 GREEN'S FRUIT GROWER
 W. F. GWIN, General Manager Northwestern Fruit Exchange, Portland, Oregon
 C. L. HAMILTON, Inspector Yakima Valley Fruit Growers' Association
 GEO. H. HIMES, Assistant Secretary Oregon Historical Society
 W. L. HOWARD, Phd., Horticulturist, Missouri Experiment Station
 V. H. HOWIE, Expert Accountant, North Yakima, Wash
 HERBERT SPENCER JACKSON, A. B., Botanist and Plant Pathologist, Oregon Experiment Station
 P. B. KENNEDY, Reno, Nev.
 EDWARD JACOB KRAUS, B. S., Research Assistant in Horticulture, Oregon Experiment Station
 MR. W. B. LANHAM, Bitter Root Valley, Mont.
 W. H. LAWRENCE, Superintendent and Plant Pathologist Western Washington Experiment Station; Plant Pathologist and Horticulturist Hood River Apple Growers' Union
 J. U. MCPHERSON, State Horticulturist, Boise, Idaho
 M. S. MIDDLETON, Horticulturist, Nelson, B. C.
 H. B. MILLER, American Consul, Belfast, Ireland
 ROBT. MORGAN, Head Inspector, North Pacific Fruit Distributors
 OSCAR MATISON MORRIS, B. S. (Oklahoma Agricultural and Mechanical College), Professor of Horticulture, Washington Experiment Station
 MR. ELIAS NELSON, Quincy, Wash.
 NORTHWEST HORTICULTURIST.
 MR. F. A. NORTON, Grandview, Wash.
 G. HAROLD POWELL, Horticulturist, Delaware Experiment Station; U. S. Department Agriculture, Pomologist and Assistant Chief, Bureau Plant Industry; General Manager California Fruit Growers' Exchange

MR. A. A. QUARNBERG, Nut Specialist,
Vancouver, Wash.

T. R. REID, Special U. S. Frost Forecaster

H. S. RHODES, M. D., Tacoma, Washington

ROGUE RIVER VALLEY FRUIT GROWERS
UNION.

H. C. SAMPSON, Secretary-Treasurer North
Pacific Fruit Distributors, Spokane,
Wash.

HON. W. E. SCOTT, Commissioner of Agri-
culture, Victoria, B. C.

AUGUSTINE D. SELBY, Chief, Department
Botany, Ohio Experiment Station

J. R. SHINN, Horticulturist, University of
Idaho

F. E. SICKLES, Secretary and Acting Man-
ager Yakima Valley Fruit Growers' As-
sociation; Orchardist

CLAYTON O. SMITH, California Experiment
Station, Assistant Plant Pathologist

R. E. SMITH, B. S., Plant Pathologist and
Superintendent of Southern California
Pathological Laboratory and Experi-
ment Station.

ROSCOE WILFORD THATCHER, M.A. (Univer-
sity of Nebraska), Professor of Agricul-
tural Chemistry, Head of the Depart-
ment of Agriculture and Director and
Chemist of the Washington Agricultural

Experiment Station; Department Agri-
cultural Chemistry University of Min-
nesota

THE FARMER AND FRUIT GROWER.

WALTER STRICKLAND THORNER, M. S.
(South Dakota Agricultural College;
Cornell University), Professor of Horti-
culture and Head of the Department of
Horticulture and Forestry, Washington
Experiment Station; Superintendent
Lewiston-Clarkston Development Com-
pany; Director Lewiston-Clarkston
School of Horticulture

R. E. TRUMBLE, Consulting Horticulturist

CLARENCE CORNELIUS VINCENT, M.S.A.,
B.S.A., Oregon Agricultural College,
1907; M.S., 1909; M.S.A., Cornell Uni-
versity, 1910; Assistant in Horticulture,
Oregon Agricultural College, 1907-09;
Graduate Student in Horticulture, Cor-
nell University, 1909-10; Assistant Hor-
ticulturist, University of Idaho, 1910

W. W. WEIR, Drainage Engineer, U. S.
Reclamation Service

GEO. P. WELDON, Entomologist, Colorado
Experiment Station

WENATCHEE FRUIT GROWERS ASSOCIATION.

J. HOWARD WRIGHT, Manager Wright
Fruit Company, North Yakima, Wash-
ington, Orchardist.

SUBJECTS TREATED

The number of subjects enumerated is over *four thousand five hundred*. A large number of these have been given special treatment; as, for example, the most important plant diseases, including Blight of Pear and Apple, Apple Water Core, Apple Tree Anthracnose or Black Spot Canker, Walnut Blight, Apple and Pear Scab, Apple Rosette, Plant Lice, Irrigation, Low Heading, Apple Packing, Fruit Marketing, Orchard Costs, Varieties to Plant, "Pedigree," Overproduction, Horticultural Laws, Canning, Preserving, Duty of Water, Drainage, Grafting Waxes, Preparation of Fruits and Vegetables for the Table, Road Building, Gardener's Planting Table, Peanut Culture, Pecan Culture, Bibliographies on All Phases of Horticulture, Statistical Maps, Fruit Statistics of All the States, Rainfall, Frost Tables, Onion Culture, History of Orcharding in the Northwest, Intercropping, Windbreaks, Nut Culture, Bee Culture, Vegetable Garden, Orchard Tools, Warehouse Equipment, Spraying Accessories, Soil Water, By-products, Cold, Cool and Common Storage, Pre-cooling, Disease Susceptibility, Descriptions of Varieties of Apples, Fertilizers, Score Card for Exhibition Pack, Mushroom Culture, Variety Adaptations, Industrial Alcohol, Trans-

portation Costs, Hybridization, Equipment of Farm Home, Evaporation of Fruits, Fruit Juices, Cost Tables, Care of Nursery Stock, Cranberry Culture in the Northwest, Forcing Orchards into Bearing, Cooperation, Strawberry Culture, Cantaloup Culture, Floriculture, Fruit Growing in the Bitter Root Valley, Vinegar Making on the Farm, Pollination Question, Complete List of Important Economic Pests and Plant Diseases, Pruning, Orchard Management, Marketing, Liquid Fertilizer, Making an Orchard Pay Before Coming Into Bearing, Value of Different Varieties of Apples, Cultivation, Propagation of Plants, Plant Physiology, in fact the whole range of subjects related to practical fruit and vegetable growing.

COOKING AND PRESERVING RECIPES

A very complete department of recipes for cooking, preserving and serving the various fruits and vegetables is given. The materials of this department were arranged by Miss Alice M. Hodge, Stout Institute, Menomonee, Wis.; Supervisor Domestic Science, Danville, Ill.; Supervisor Domestic Science, Stevens Point, Wis.; five years Supervisor Domestic Science, North Yakima, Wash.

SPRAY FORMULAE

All the known spray mixtures are given under the head of Spraying and Spray Materials. These are in many cases repeated in connection with the particular pest or disease treated.

ILLUSTRATIONS

In all there are about seven hundred and fifty illustrations, of which one hundred and twenty-four are line etchings, six hundred and twenty are half tones from copper plates and six are three- and four-color process plates.

Sixty-six are full page plates, one hundred and ten are half page, others number five hundred and seventy-four. Altogether the illustrations cover two hundred and sixty pages.

CHARTS AND TABLES

Scattered throughout the work, there are numerous charts and tables covering altogether one hundred and sixty-five pages. These charts and tables deal with the statistics and costs of production of the various crops treated, the number of plants per acre on the various plans of setting out, quality of fertilizer to be applied and manurial value of cover crops, amount of fertility removed by various crops, food values and chemical constituents of fruits and vegetables, frost and precipitation in the various states, etc.

North Yakima, Washington,
August 24, 1914.

WM. WORTHINGTON,
Associate Editor.

Encyclopedia of Practical Horticulture

ADAPTATIONS OF PLANTS See *Plant Physiology*.

AGE OF APPLE TREES See *Oldest Orchard in the Yakima Valley*

AGE OF TREES, HOW DETERMINED See *Nursery* under *Apple*

Agriculture

AGRICULTURE is the cultivation of the soil for food products, or for any other useful or valuable growths of the field or garden, tillage; husbandry; also by extending the meaning it has come to include any industry practiced by the cultivator of the soil in connection with such cultivation, as forestry, fruit-raising, breeding and rearing stock, dairying, market gardening, etc.

FARMING refers to the cultivation of considerable portions of land, and the raising of the coarser crops. GARDENING is the close cultivation of a small area of small fruits, flowers, vegetables, etc., for the household, or market. FLORICULTURE, the culture of flowers, HORTICULTURE, the cultivation of fruits, flowers or vegetables.

HUSBANDRY is a general word for any form of practical agriculture, but is now chiefly poetical.

TILLAGE refers to the work practically applied on the land, such as plowing, harrowing, manuring, etc.

CULTURE is now applied to the careful development of any product to a state of perfection, especially by care through successive generations; the choice varieties of strawberry, for instance, have been produced by wise and patient culture.

—STANDARD DICTIONARY

AIR DRAINAGE See *Apple Orchard, Selecting a Site For*.

Alabama

Alabama has an area of 52,250 square miles, and is bounded on the south by Florida and the Gulf of Mexico, which

latter fact tempers its heat in summer. The Tennessee river, and its tributaries, is a drainage system for the northern part of the state, and the Valley of the Tennessee is one of the most famous agricultural sections of the lower Appalachian system. It is a delightful country, gently rolling, varying in elevation from 500 to 800 feet.

The Mobile river system, which empties into the Mobile bay, drains the principal part of the state. Its largest tributaries are the Tombigbee and the Alabama rivers. The so-called mountain system of Alabama hardly rises to the dignity of mountains, for the highest points are only about 1,800 feet above the sea. The surface in the north and northeast, embracing about two-fifths of the state, is diversified and picturesque. The remaining portion is occupied by a slightly undulating plain, having its incline towards Mississippi and the Gulf. Extending entirely across the state for about 20 miles south from its northern boundary, and in the middle stretching about 60 miles farther south, is the Cumberland Plateau, or Tennessee valley region, broken into broad table lands and dissecting rivers. In the northern part of this plateau, west of Jackson county, there are about 1,000 square miles of level land from 700 to 800 feet above the sea.

The climate for the most part of the state is semi-tropical and temperate. In the hill regions, the air is pure and the climate salubrious. The sea breezes temper the heat along the Gulf, and the ranges of hills break the winds in the northern part.

At Mobile the annual mean temperature is 67 degrees. The annual mean temperature for summer is 81 degrees and in winter it is 52 degrees. At Valley Head, DeKalb county, the annual mean temperature is 59 degrees, in summer 75 and in winter 41 degrees.

The soil of the southern part is formed from drift over cretaceous and sedimentary rocks which are, in some parts, rich in fossils. In the central portion the formation is metamorphic and calcareous, with silurean sediments and coal measures.

The Valley of the Tennessee is generally a deep red calcareous soil, which, in the metamorphic region is a red or clay loam with a sand or clay subsoil.

In the north the soil is very generally sandy, with a sand or clay subsoil.

The native trees are mainly the different varieties of oak, pine cedar, chestnut, butternut, black walnut, hickory, poplar, linden, magnolia and red plum.

The soil, climate and the facilities for transportation justify a larger production of fruit for commercial purposes than has, up to this time, been developed. As we traveled through the northern part of the state, and examined the soil and native trees, together with the topography of the state, we could see no reason why commercial horticulture could not be brought to a much higher standard than at present. In all parts of the state certain kinds of fruits are grown for commercial purposes; but not generally in large quantities. In the southern part truck farming and gardening are extensively carried on, with Mobile as the principal shipping point, while in the northern part apples, peaches, and pears are grown in considerable quantities. Probably there is no Southern state where soil, climate and natural conditions are better adapted to the growing of peaches, pears, plums, prunes, cherries, small fruits and apples than the mountain and hill regions of Alabama. Here too are some of the largest nurseries in the United States. The fact that those growing nursery stock for wholesale purposes find conditions so favorable to their business is evidence that trees will make a vigorous and healthy growth in this section; for among the large nurseries in Alabama comparatively a small per cent of the stock is planted in that state, but is shipped largely to all fruit growing sections of the United States.

GRANVILLE LOWTHER

Southern Alabama

This is one of the oldest truck growing sections, as the early French settlers met success with their early gardens here. The vegetables shipped out of Mobile from this area aggregate a million dollars in value every year. Satsuma oranges and pecans are being heavily planted in this section, and the country is being rapidly filled up with northern farmers

Many attempts have been made at commercial peach orcharding in different sections of the state. Where failure was made it was due mostly to the lack of proper organization in shipping; and perhaps as much was due to the ravages of *brown rot* and late frosts in the spring. In Baldwin and Mobile counties in the southern part of the state, this is particularly true. In the nineties several carloads of Elberta, Greensboro and Carman peaches were shipped out from these counties. These orchards were located at Semmes, Bay Minette, Orchard and other small towns in that locality.

A large fruit growers' organization planted at least 3,000 acres of grapes in the vicinity of Fruithurst in Cleburne county during 1894-95-96, but owing to the ravages of black rot and poor management, together with overdoing the planting, the venture was not altogether successful. However, grapes are being very successfully grown in all sections of the state, particularly such varieties as Scuppernong, several varieties of the Muscadine as James, Flowers and Thomas, and also bunch grapes such as Concord, Delaware, Niagara and Ives.

The nursery business in the Huntsville district in Madison county has steadily grown and prospered. About 2,000 acres are now devoted to this industry, and Alabama grown nursery stock is known for its vigor and cleanliness in every fruit section of the country.

A rather novel horticultural industry is one which has been established about Evergreen in Conecuh county and at Eufaula and Louisville in Barbour county. Southern smilax, or "bamboo vine," as the boys call it, is gathered by whites or blacks in one-mule wagons and

brought into the warehouse and sold to shippers as they would sell cotton. The smilax is packed carefully in light wooden boxes and it is then shipped by express to the northern cities. The height of the season comes just before Christmas, and the smilax together with holly brings a considerable income to the people in these counties.

There are few places in Alabama where some kind of fruit cannot be grown with good profit.

The Apple

The northern half of the state produces apples abundantly, and they bring a fancy price when care is given to their culture. A number of orchards that have been well cared for produced this past season, at the age of eight years, eight to ten boxes of fruit per tree that sold for \$1.50 per box. By intercropping, the cost of the orchard will scarcely be worth mentioning until it comes into bearing, outside of the land, trees and planting. The average orchard contains about 48 trees to the acre, 30x30 feet, and with standard varieties from the eighth year will produce from \$8 to \$12 per tree per annum, which makes a net profit of from \$200 to \$300 per acre. Several growers in 1912 obtained results equal to the above, and one much better. A grower in Cullman county made \$600 per acre on eight-year trees.

Pears

Pears grow well in all parts of the state, wherever they are provided with well drained soil. From 60 to 100 trees may be grown on an acre, and on healthy, well-manured trees from 15 to 25 bushels may be expected. Several growers reported an average of 20 bushels per tree. With 60 bearing trees an acre will produce from 400 to 800 bushels. Pears readily sell for \$1 per bushel, and often bring more. One grower reported his pear orchard netted \$800 per acre, while several others made a net profit of \$600 per acre.

Excellent crops of the Sand Pear and Keiffer were produced as far south as Mobile.

Peaches and Plums

Peaches and plums are two fruits that may be considered the most important commercial crops grown in the South. Little has been done toward proving the success of the plum in this state. Those who have grown plums have succeeded very well. About 134 trees can be grown on an acre 18x18 feet each way, and at a bearing age will produce from one to three crates per tree, which gives an annual yield of from 134 to 200 crates per acre. Plums find a ready market, and sell for a fancy price. With good care from \$200 to \$300 per acre can be realized.

The peach can be grown in all parts of the state if it is provided with good soil. The conditions for growing peaches in this state are as good as in Georgia. About 134 trees can be grown on an acre, planting 18x18 feet, and from four to six years will produce from one to four crates per tree of marketable fruit, which nets about \$150 per crate, making from \$200 to \$300 per acre net profit. With proper spraying, pruning, fertilizing and cultivating one can easily realize a net profit of \$200 per acre per annum. The 1912 season peaches were shipped in car lots from several points in the state. At more and Camp Hill, several carloads; Gadsden, 30 cars; Union Springs, 100 cars.

Grape

The grape is a fruit that usually receives very little attention. Often it is not provided with a good trellis and seldom gets pruned. If it is half cared for it will produce good fruit, and if well cared for will produce a profitable crop. A few growers have found the grape to succeed well. One man who is growing grapes for the market realized in 1912 a profit of \$600 per acre off a four-year vineyard. Grapes sell readily and come at a season when other fruits are scarce. An acre will produce from three to four tons of fruit and the choice fruit will bring 25 cents per basket or 10 cents per pound. Concords from New York sold for 14 cents per pound, 1912 season. The farmers of Alabama could supply

the demand as well as allow other states to do it.

Strawberries

Strawberries are unlimited as to territory and variety of soil. If the soil is well drained and contains some humus strawberries grow well and are very profitable, and come at a season when a farmer has no other crop to put on the market. They will produce about 100 crates per acre, and net \$1.95 per crate, which makes a net profit of \$195 per acre. Twenty to thirty cents per quart can be realized for the first berries, if first-class. A large number of farmers have already engaged in growing strawberries and find it very profitable. The crop comes in several weeks earlier in this state than it does in the northern states; consequently there is less competition. In 1908 and 1909 over 5,000 crates were shipped out of Cullman; 1910, 100 carloads.

Oranges

The Satsuma orange does well in the southern part of the state. Considerable territory is well adapted to orange culture in Mobile and Baldwin counties. About 134 trees can be grown per acre, 18x18 feet. In Mobile county two-year trees produced from 100 to 200 fruits and four-year trees produced from 400 to 500 fruits. A grower in Baldwin county in 1909 gathered 90 dozen fruits from one tree. The same grower sold \$1,400 worth of fruit from two and one-half acres. His fruit averaged \$18 per barrel. The trees are hardy in the above section and have withstood cold as low as 18 degrees above zero. There is such a demand for Satsuma oranges that very few of them are shipped any distance, being consumed near the place where grown. A grower in Mobile county netted \$700 per acre the 1912 season.

Pecans

The pecan is another fruit that is unlimited in this state as far as climate is concerned, and bears a fair crop, while in the southern half of the state it is very profitable as a commercial crop. If furnished with a good soil and proper culture the pecan will do the rest. Some

growers near Selma state that their pecan grove yielded the first commercial crop at the age of 10 years, and they harvested one bushel of nuts per tree. A bushel of pecans weighs 40 pounds, and as low as 25 cents per pound would bring \$10 per bushel or tree. This is a very low price for pecans, as grafted and budded nuts never sell for less than 50 cents per pound and as high as \$1.25 per pound. The choice nuts are consumed locally, leaving none for export.

The yield will increase as the trees grow older, and the grove will prove a big money-making crop for a number of years to come. Trees in full bearing yield from 100 to 200 pounds of nuts. Selling at 50 cents per pound would be from \$50 to \$100 per tree, and at \$1 per pound would be from \$100 to \$200 per tree. A large number of people have engaged in the industry. One company has 2,400 acres in pecans.

Persimmons

Japanese persimmons can be grown in nearly all parts of the state. About 150 trees can be grown on an acre, and the trees will produce from 200 to 500 fruits per tree. The fruits sell for 2 cents a piece, and find ready sale on the local markets, as the production is not sufficient to require shipment except at a few points. The trees are hardy and require but little care. An acre will net from \$200 to \$500.

Pomegranates

Pomegranates grow well in all parts of the state and require but little attention. The trees bear heavily, and the fruits sell for \$2 per 100, finding a growing demand on the market.

Figs

The figs thrive on a great variety of soils, and can be grown in the greater part of Alabama. The trees are quite hardy in the southern half of the state and very productive. A tree in full bearing will produce from two to six bushels of fruit. The fruit sells readily, bringing from 80 cents to \$1 per bushel. The trees will stand more neglect than any other class of fruit and will respond to good culture just as quickly. From 150

to 300 trees may be grown on an acre, and the average tree will produce one bushel of fruit, which will make from 150 to 300 bushels, netting \$100 to \$200 per acre. This is a low estimate for the

fig. This fruit demands the highest price when canned, and finds ready sale on the market, bringing 35 cents per can. The fig is an easy fruit to can.

W. P. WILLIAMS

Station	FROST				Precipitation, Annual Inches
	Average Date of		Date of		
	First Killing in Autumn	Last in Spring	Earliest Killing in Autumn	Latest in Spring	
Florence.....	Oct. 31	April 1	Oct. 25	April 9	50.3
Decatur.	Oct. 15	April 5	Oct. 2	April 15	49.5
Valley Head...	Oct. 20	April 5	Oct. 6	April 30	54.4
Oneonta.....	Oct. 15	April 10	Sept. 4	May 2	53.7
Birmingham.....	Nov. 5	Mar. 19	Oct. 22	April 10	56.8
Annistown.....	Oct. 20	April 2	Oct. 6	April 20	49.1
Tuscolusa.....	Nov. 6	Mar. 23	Oct. 21	April 9	49.5
Good Water.....	Nov. 9	Mar. 20	Oct. 18	April 8	48.9
Greensboro.....	Nov. 8	Mar. 20	Oct. 24	April 5	48.5
Pushmataba.....	Nov. 12	Mar. 21	Oct. 25	April 5	52.8
Montgomery.....	Nov. 8	Mar. 11	Oct. 21	April 5	50.8
Opilika.....	Nov. 9	Mar. 17	Oct. 25	April 1	49.1
Eufaula.	Nov. 9	Mar. 14	Oct. 25	April 1	51.1
Evergreen.	Nov. 12	Mar. 13	Oct. 24	April 5	51.0
Momible	Nov. 30	Feb. 21	Oct. 31	Mar. 28	62.1

For bloom periods of apples in Southern Alabama, see *Louisiana*, where conditions are similar.

Alaska

Alaska is the northwestern extreme of the Cordilleran system of mountain ranges that extends through North America from north to south along the Pacific Ocean, through the central part of the United States, and include that great central range called the Rocky Mountains, also the Cascades, the Sierra Nevada in California, Sierra Madre in Mexico and Central America, and the Andes in South America. Panama is a mountain pass, dividing this range of mountains which is the same range no matter by what names its parts are called in the different countries; it is the same formation caused by the same action of the shrinking of the earth and the consequent uplift of parts of its surface, and the destruction of other parts. The highest peak in the range is Mt. McKinley, over 20,000 feet high; rugged, cold, defiant, it stands like a lone sentinel in the far north.

The country was purchased by the United States for \$7,200,000, or about two cents per acre. Considering the distance north, the climate along the coast is mild, for it is washed by the Japan Current which warms its temperature. However, the coast line is rugged, the valleys small,

and the heavy rainfall is unfavorable for the growth of many kinds of agricultural products. The interior is drained by the Yukon river. This interior is a great basin which is similar in some respects to the other interior basins near the Pacific Coast where the difference in climate as compared to the coast region is very great. The basin east of the mountain range is warm in summer and exceedingly cold in winter. The rainfall is slight and the growing period in the Yukon Valley is only about four months. Judging from the abundance of native fruits, especially of berries, it is believed that varieties from the states can become acclimated and grown with some degree of success.

In his 1912 report C. C. Georgeson, who has charge of the Alaska Experiment Stations, and who is doing much to introduce hardy fruits into that country and to develop hardy varieties adapted to the conditions, says:

Potato Crop

"Potatoes were grown on a commercial scale at Fairbanks, and for profit. The object is to demonstrate that farming can be made to pay in Alaska. The station is somewhat handicapped in carrying out this plan because it does not want to go into competition with

the market gardeners of the vicinity. If it were not for this, the financial side would show up better than it does. Nearly everyone grows potatoes, and the number of tons which are imported from the Puget Sound country has been materially reduced by the growing of the native product; yet it is estimated that not less than 500 tons were imported for use at Fairbanks and the camps on the various creeks in that region during the past season. This being the case, it is not considered that the station entered into competition with potato growers. Last year some 30 tons of potatoes were raised on nearly seven acres of land. This year more than a thousand bushels were grown on five acres, which shows an average yield of 200 bushels per acre. Aside from growing a crop for marketing, many different varieties were planted in order to determine which of them are the best suited for that region.

"The crop has not been sold at this writing, and the price will be low compared with the price of former years, but the crop from these five acres may sell for at least \$2,000, or at a rate of \$400 per acre, which will afford a good profit. It is a question whether the potato market will continue to be profitable, however. The population gradually diminishes as the placer ground is worked out, and the homesteaders are gradually extending the area in potatoes. The time will come when the price of the native-grown potato will be so low that there will be no profit in it.

"In this connection it is well to call attention to the fact that potatoes grown on lowlands, as a consequence suffer from early frosts and seldom mature normally. They are therefore soft and watery when cooked, and when placed on the market they ruin the reputation of the Alaska-grown potato. Ranchers should transfer their potato growing to southern slopes of the low hills. There they will grow a potato of better quality which will not be discredited in the market.

"Attention is again called to the fact that there is a great difference between varieties of potatoes. The early maturing

sorts are better suited to this country than the late potatoes. Only early varieties should be grown, and of the early varieties the best cookers should be selected for culture. If these points were heeded, the consumer would not discriminate against the native potato in favor of the outside product as is now the case.

"It is desired to emphasize once more that the results of sprouting the seed before planting, which have been attained at both the Rampart and Sitka stations are greatly in favor of this practice. It is not practicable to sprout the seed when several acres are to be planted—not unless special provisions are made for so doing.

Cabbage

"Next to potatoes cabbage is the most important garden vegetable. Nearly every settler aims to raise a few heads, and in the towns cabbage is an important market vegetable. It is always a leading crop with professional market gardeners. However, since land is abundant and town dwellers quite generally cultivate part of their lots, householders who have the time and inclination very generally raise at least a portion of the cabbage as well as other vegetables which they consume. Seed was sown March 27 of all the varieties mentioned below and the plants transferred to cold frames April 18. On May 27, 50 plants of each variety were set in the field. The percentage of marketable heads of each variety was as follows:

<i>Percentage of marketable heads of cabbage produced in 1912.</i>	
	Per cent.
Copenhagen Market.....	92
Danish Ball Head.....	56
Dark Red Stonehead.....	90
Early Baseball.....	86
Early Jersey Wakefield.....	94
Early Winningstadt.....	82
Holstein.....	82
Large Late Drumhead.....	80
Large Late Flat Dutch.....	88
Market Gardener Flat Dutch.....	88
Savoy.....	50

"The Early Wakefield has, all things considered, been the most satisfactory variety so far tried. It stands the test year after year. It is a sure header, and

while the heads are not large they are of good quality. Other varieties approach it closely, but none excel it. As a matter of fact, it is not always the earliest variety. Others, even those so-called late, are sometimes earlier. Its value rests chiefly in the fact that it can be depended upon to head under nearly all circumstances. Other varieties are less dependable.

Cauliflower

"The cauliflower is at home in Alaska. It has larger, more crisp heads, and is better flavored here than it is when grown under a hot sun. It follows cabbage in point of importance. It has one drawback, however, and that is that it is only a summer vegetable, whereas cabbage can be kept all through the winter. It is grown exactly as we grow cabbage—raise the plants in boxes or in cold frames, transplant the seedlings into other boxes or cold frames four inches apart to give them room to develop well and to acquire a good root system. Transplant in the open ground two feet apart in the row, and the rows three feet apart. The transplanting is done as in the case of cabbages with a ball of earth so that the roots are disturbed as little as possible; and they should not be set in the open until the latter part of May. Thus treated, and given a good garden soil, the cauliflower is one of the most satisfactory vegetables that can be grown. It is ready for the table earlier than cabbage. Market gardeners in the coast towns of Alaska have them sometimes for sale as early as July 4. Of course the earliness, as in all vegetables, depends very largely upon the nature of the season. When the spring is early and the summer warm they grow rapidly, and mature early; when the spring is late and the summer cloudy and rainy, as is often the case, they mature late. Only a few varieties are grown here, as listed below. The seed was sown March 27 and the plants transferred to cold frames April 18. On May 27, 50 plants of each variety were set in the field. The date of maturity and the percentage of marketable heads of each variety are shown in the following table:

Variety tests of cauliflower, 1912

Variety	Small heads matured	Marketable heads
		Per cent
Denmark	July 26	90
Extra Early Dwarf Erfurt.	July 18	92
Extra Early Paris	July 28	88
Extra Early Snowball.	July 20	90
Gilt Edge.	July 22	90

Broccoli

"Broccoli is similar to cauliflower. This vegetable has practically the same quality, matures later, and is not quite as sure to head. It should be treated in all respects like cauliflower. Some varieties are white, in which case they closely resemble the cauliflower. Other varieties have purple heads. Three varieties were grown in the past season—Early White, Early Purple Cap, and Mammoth White. The seed was sown March 27, the plants transplanted to cold frames April 18, and to the field May 27. Early White matured heads on August 1, 78 per cent of which were marketable, and Mammoth White on August 20, of which 76 per cent were marketable. Early Purple Cap did not mature any heads.

Kale

"Kale is a valuable vegetable, but unfortunately not appreciated. It is particularly well adapted to a cool, moist climate like that of Alaska, and on the other hand kale grows but poorly under a hot sun or in dry weather. Now, since the majority of settlers in Alaska have come from the regions south of latitude 49°, kale is but little grown. This may be the reason why it is not appreciated; and because it has been so little used in the states many housewives do not know how to prepare it for the table. The writer has received letters from people who have grown it and reported splendid success in growing large vigorous plants, but they called it poor provender; they had tried to eat it raw as a salad. Kale must be boiled thoroughly and should be cooked preferably with salt pork or corn beef; when so prepared it will be found a very appetizing dish.

"One of the chief merits of kale is that it is a winter vegetable. It can stand

a moderate degree of frost, and indeed its quality is improved by freezing slightly. In the coast regions it can, therefore, be left outdoors the entire winter and cut as needed. In very cold weather, a foot or more of snow is a protecting blanket to the plants.

"Treat kale exactly like cauliflower. The dwarf curled varieties are to be preferred. The tall coarser varieties can be grown for cattle feed, the only objection to this being that they will flavor the milk as do turnips, cabbage, and all other Cruciferae.

"Dwarf Scotch, Green Curled and Siberian kale were sown in the open field May 27 and were ready for use September 15 and 20, respectively, 96 and 94 per cent of the plants being marketable. Brussels sprouts sown March 27, transplanted to cold frames April 18 and to the open field May 27, was mature October 27, 90 per cent of the plants forming marketable heads.

Brussels Sprouts

"This is a vegetable that deserves to be more generally cultivated than is the case. It is really a variety of kale and is cultivated in exactly the same manner as kale and cauliflower, but the stalks grow taller than kale, and in the axil of each leaf is formed a small head, which is the portion used. These little heads properly cooked are most delicious. They are better flavored than either cabbage or kale. In the coast region the plants can be left outdoors until moderately cold weather sets in. They are not quite as hardy as kale. But one variety was grown here the past season. It is listed above with the kale.

Turnips

"Eight varieties of turnips were grown here, each in a 50-foot row, with yields as follows: Petrowski, 150 pounds; White Milan, 140 pounds; No. 33682, 133 pounds; No. 33684, 127 pounds; No. 33683, 97 pounds; No. 33687, 46 pounds; No. 33685, 31 pounds; No. 33686, 18 pounds.

"The seed of those sorts designated by numbers were obtained from the Seed Di-

vision of the Department of Agriculture. None of them appear to have any great merit.

"The Petrowski is undoubtedly the best variety so far found for Alaska. It has not as yet been offered by seedsmen in this country. The seed which has been grown at the experiment stations and which has been distributed to all the correspondents of this office has been imported from Finland. It is a yellow, smooth, uniformly shaped turnip of delicious quality. It grows well everywhere and as noted below it is not greatly subject to the attacks of root maggots. About 2,000 packages of this seed have been distributed to settlers in Alaska, and all who have reported, speak in the highest terms of this variety. It is earnestly urged that all who have grown good turnips should save the best, wintering them free from frost with a view to planting them out for seed the following spring. Plant them early in rows three feet apart and two or three feet apart in the row. When the stems grow up they should each be tied to a stake. Gather the seed as soon as it matures. This variety is worthy of perpetuation.

Root maggots.—These pests are quite prevalent in Alaska, and complaints of their ravages come to this office from all parts of the territory.

They attack turnips, cabbage, cauliflower, kale, and in fact all members of the Cruciferae and other plants.

The maggots are the larvæ of small flies somewhat resembling the house fly, which lay their eggs on the leaves near the base of the plant. When the eggs hatch, the maggots wriggle into the ground and begin to feed on the roots near the surface. They grow rapidly and when numerous they soon suck the juice from the plant, causing decay to set in and the plant dies. Some varieties of plant are more susceptible to the ravages of this pest than others. The Petrowski turnip, for instance, is almost exempt, while other varieties of turnips grown alongside suffer badly. The reason for this fact is not fully known, and may be due to the habit of the plant, which

spreads its leaves flat on the ground. The leaf stems are not upright as in many varieties, and the maggots, therefore, do not follow the stems to the ground at the base of the plant; they are already on the ground. If this is not the correct explanation, it is at least plausible. The root maggots are not troublesome at Sitka, and therefore there has been no opportunity to experiment with remedies.

Carrots

"On May 15 a row 100 feet long was sowed to each of the following varieties of carrots. They were all ready for market on October 1, although they were not dug until some time later. In point of yield they rank in the order mentioned: Stump Rooted, 181 pounds; Yellow Danvers, 138 pounds; Chantenay, 117 pounds; French Forcing, 113 pounds; and Early Scarlet, 110 pounds.

"Carrots are also a neglected vegetable. They can be grown successfully almost anywhere in Alaska, but they require a well drained soil, and the richer the ground the better the crop.

Beets

"But one variety of beet was grown last season, namely, Extra Early Egyptian. The seed was sown on May 15 and produced medium sized roots of good quality by September 15.

Swiss Chard

"Swiss chard is a kind of beet grown for its leaves. The stems are crisp and palatable and used as a salad. It does well in Alaska. The seed was sown on May 15. September 15 it was ready for use; was 18 inches high and of good quality.

Celery

"Three varieties of celery were grown on a very small scale here. They were Giant Golden Heart, Golden Self-blanching; and Rose Ribbed. They rank in the order given.

"Celery can be grown with great success in Alaska, provided conditions are right. In a poor soil poorly drained, it amounts to nothing. The seeds should be sown in flats or boxes in the house, greenhouse, or cold frame in the latter

part of March. When the plants are an inch high or less, they should be transplanted in rich soil under glass about four inches apart, and about the beginning of June they can be set in the open ground.

"Celery is always planted close together because it facilitates the blanching of the stems and a large number of plants can be grown on a very small area. A bed may thus be prepared of light, that is to say, more or less sandy soil in which five or six inches of decomposed manure has been dug in and thoroughly mixed with the soil. Set the plants in this bed six inches apart each way for the smaller varieties and seven or eight inches apart for the larger varieties. Inclose the bed with boards which are kept as high as the top growth. The so-called self-blanching varieties will blanch in the partial darkness caused by the dense growth of leaves. Other varieties can be blanched by filling in soil between the plants, and they will be ready for market as soon as they are large enough to use, which may be the latter part of July if the plants are started early.

"Celery grows better in the interior than in the coast regions, because the summers are warmer, and all vegetation grows rapidly. The writer has never seen or tasted better celery than that grown by market gardeners at Fairbanks.

Celeriac

"Celeriac is a variety of celery. It develops a large root like a turnip or rutabaga, and it is grown for the root. It is rarely cultivated in America except in German settlements, but it is a most delicious vegetable which can be used either raw as a salad or better still sliced and boiled in soups and other dishes. The plants are raised like celery plants and planted out 15 to 18 inches apart in the row in rich soil.

"Both celery and celeriac require a moderately dry soil. They are failures wherever their roots are continually wet.

Salsify

"Commonly known as oyster plant from the fancy that its root resembles the oyster in flavor. Salsify has not succeeded

well at the Sitka Station. The soil is too wet. It requires a light, loamy, well-drained land for its best growth, but it can be grown in Alaska and will add a variety to the available vegetable dishes.

"One sort, known as the Thick Rooted, was grown the past season. The seed was sown in the open on May 16 and produced medium sized roots by October 1.

Lettuce

"Nine varieties were grown on a very small scale the past season. The seed was sown in the open May 15, and when the plants were up they were thinned to a stand of six inches apart in the row. The varieties grown were valued for earliness, quality, size, and solidity of head in the following order: Tennis Ball (black seeded), Giant Crystal Head, California Cream Butter, Rheingold, Buttercup, Iceberg, Beacon, Maximum, and American Gathering.

"Lettuce is easily grown everywhere in Alaska, and it is a favorite salad with everyone. In passing through the country one sees at the isolated prospector's cabin, as well as at the more comfortable homes in town, a little patch of each of three vegetables. They are turnips, lettuce, and radishes, the two latter always grown on a very small scale, perhaps confined to a single square yard. The average cultivator takes no pains with his garden. He sows the seed thickly and cuts the plants when they are large enough to use. This is one way of doing it, but a poor way. Lettuce can be had throughout the summer by making several seedings, say once in four weeks, from April to July. Then the best results are obtained by sowing the seed in shallow boxes, and when the plants are two inches high set them in rows some six inches apart on rich soil. Those varieties which produce a solid head are to be preferred, but they are not as early as those which have a loose head. Solid headed lettuce sown in June or the beginning of July will be ready for use in September, and the heads can be kept until quite late in the winter in a dry, frost-proof cellar.

Parsley

"Parsley is one of the few greens which is grown for the flavor it imparts to dishes, and also for decorating dishes. There should be at least a short row of parsley in every garden. It is sown in the open in early spring. The plants should be thinned if they are too thick. The seed takes a long time to germinate, and it loses its vitality very soon, hence old seed should never be used. There are but few varieties; Extra Curled is the one most commonly grown. There is also a root parsley with plain leaves, the roots of which are used in soups, and with other vegetables, like celeriac.

Spinach

"Round Viroflay and Long Season were successfully grown at the Sitka Station the last season. Spinach does not succeed everywhere. It is a little particular about the soil. The soil should be well drained. In a wet soil it runs to seed almost at once without producing leaves. Sow it the middle of May.

Radishes

"A 50-foot row was seeded of each of the three following varieties. They all did well, and they are valued in the order named: Early Scarlet Turnip, French Breakfast, Deep Scarlet Olive-Shaped. It is superfluous to say anything here about the culture and use of radishes. Everyone knows and appreciates them."

FRUIT TREES

Apples

The following varieties of apples are grown in the small test orchard at the Sitka Experiment Station. It will be noticed that most of them are crabs or crab hybrids. These trees were planted in 1903, except those which have been planted to replace others that have died. They were, therefore, nine years old the past season and old enough to bear fruit. In 1911 the following varieties fruited: Raspberry (crab), Yellow Transparent (crab), Hyslop (crab), Whitney (crab), and Sylvan Sweet (crab).

The past year the only varieties which set fruit were Whitney, Tetofsky, Hyslop,

Raspberry, Patten Greening, Duchess, *Pyrus baccata*, and, of course, the native crab. Those which matured were the Whitney, Hyslop, *Pyrus baccata*, and the native crab. The fruits on the others blew off before they matured. None of the trees is doing as well as one could wish. Both climate and soil are unpropitious. Trees which have been sent from this station to settlers at Haines, Alaska, are doing better than they are doing here. The soil is better and the rainfall is less. Nevertheless the fact that apples have matured here argues that it can be done again. The summer of 1911 was long and favorable, above the average. The summer of 1912 was rather cool and the trees consequently did not do well. It is evident that none but hardy and early maturing varieties—that is to say, varieties which would be early summer apples in the states—can be grown here with any expectation of success. It is hoped that new varieties may be developed suitable to this country, but as yet the experiments have been without success. A small nursery is maintained chiefly with a view to propagating trees to be tested elsewhere. As a whole it may be stated that the outlook for apple growing in Alaska is not bright.

Cherries

There are at the station a few types of each of the four varieties of the sour cherries—English Morello, Ostheim, Early Richmond, and Dyehouse. The Early Richmond is the best of the four varieties. They have been in the orchard nine years and began to bear fruit five years ago. They are holding their own, making a moderate growth each year, and bear a little fruit, but are not at home here. They are not doing as well as they would south of latitude 49°. The fruit on all varieties was ripe the past season about August 20.

The sweet cherry, a few kinds of which are also grown at Sitka, has proved a failure.

Plums

A number of young plum trees are under test, mostly hybrids produced by

Prof. Hansen, of South Dakota, but none of them is doing well. The coast climate is apparently too wet, and none of them ever showed fruit. The wood does not mature well. The rainfall stimulates growth until frosts, and then the tender shoots die back from two to twelve inches. They succeed better in a drier climate, even though the winters are much colder than they are here. So far not a variety of plum gives promise of being a success here.

FRUIT BUSHES

Small fruits and berries succeed well in Alaska. The fruit crop of the territory will be confined chiefly to these.

Currants

The currant leads the list. It is indigenous to the mountains of Alaska, and may often be found as far north as Rampart, where the writer has repeatedly gathered ripe wild currants. The currant is not only suited to the climate, but it has the advantage of being easily propagated. It grows from cuttings without trouble, and there is no reason why every garden in the territory up to and even beyond the Arctic Circle should not have currant bushes enough to supply the needs of any family. The same varieties that have been reported on in former years are growing at the station—Red Cross, Ruby Castle, Victoria, Fay Prolific, Wilder, also the so-called common Red Dutch and White Dutch. Ruby Castle is perhaps, all things considered, the best variety so far tried. It has a large berry, is moderately prolific, and matures usually a little earlier than the others named.

The native wild red currant is also grown, but it is not yielding fruit as well as the cultivated sorts, although the fruit matures earlier than the former.

Black Currants

These also do well here, but they are somewhat more tender than the red currant. Two species of the black currant are indigenous to the coast, but they do not range as far north as the red currant. Like the latter it is easily propagated from cuttings and can be grown anywhere in the coast region.

Gooseberries

The gooseberry is not as hardy as the currant, but it is essentially adapted to a moist climate, and therefore it does well in the coast region. In the interior it will require some winter protection. It is not so popular as the currant, probably because the latter is so extensively used for jellies, whereas gooseberries are usually eaten ripe or canned green. Another trouble is that the gooseberry is difficult to propagate. It does not grow readily from cuttings. The best method is to layer the branches, and when they have taken root, cut them loose from the parent plant and set them out in nursery rows. They can be propagated from soft-wood cuttings under glass, but the average pioneer is not prepared to do this. Because of the difficulty of propagating the gooseberry plants are priced high in nurserymen's catalogues, which in a measure deters people from planting them. Nevertheless, gooseberries can be successfully grown in the coast regions of Alaska, as has been demonstrated for some years at the Sitka Station. The varieties grown are as follows: Champion, Columbus, Industry, Red Jacket, Smith Improved, Triumph and Whitesmith. The Whitesmith has a large green berry when ripe, very juicy, and on account of the size of the fruit may be considered the best of those named. Mildew or other diseases common to the gooseberry in the states have given little trouble. The date on which the berries ripen varies considerably with the season. The spring of 1912 was very early, and therefore the berries ripened early—that is, by the middle of August. In 1911 they did not ripen until fully three weeks later.

Raspberries

All varieties of the raspberry started growth early and by May 1 the leaves were well developed. The crop of fruit was not as heavy as last year, however, nor did it show as large nor as uniform berries. The volcanic ash which fell June 7 to 11 affected the foliage unfavorably, which doubtless had much to do with the fruiting. The berries of all

sorts began to ripen August 8, and they continued to fruit approximately for four weeks. The Cuthbert, all things considered, is the best variety tried. Other varieties are: Miller, Turner, Fuller, Champion, Orange, Louden, and Superlative.

Hybrid Raspberry-Salmonberries

Several of these hybrids which have been mentioned in former reports fruited last year, but the berries are unfortunately no improvement on those produced by either parent. There is a very great variation in the plants. They vary in vigor and in foliage all the way from the pure raspberry to the pure salmonberry. The Cuthbert raspberry was the mother plant. Those which resemble the salmonberry more closely are the more vigorous, while those that resemble the raspberry are small, spindling, and apparently of no value. None of the plants are prolific bearers. A number of younger seedlings are coming on, and their behavior is awaited with interest.

GRANVILLE LOWTHER

ALBEMARLE PIPPIN. See *Yellow Newtown*.
Under varieties of apples to plant.

Alcohol

Industrial Alcohol—Sources and Manufacture

The term alcohol, as used herein, signifies that particular product which is obtained by fermentation and distillation of solutions of sugar, and which is known to chemists as "ethyl alcohol." It is a colorless and mobile liquid which has a peculiar "spirituous" odor and a sharp and burning taste. When it is left in a crude condition, both its odor and its flavor are rendered somewhat disagreeable by impurities which originate in the earlier stages of manufacture; but when it has been purified thoroughly—in which state it is commonly known as "neutral" or "cologne" spirit—it acquires a distinctly agreeable smell. It mixes freely with water, in all proportions; and, as is well known, it is the essential intoxicating ingredient of all

the fermented and distilled liquors. When "strong," or nearly free of water, it dissolves gums and resins very readily, and burns with an intensely hot, pale-blue flame. Because of these characteristics it is used in large amounts in the preparation of certain varnishes, and as a fuel in cases where its cleanliness, intense heat, and freedom from danger of explosion offset its expensiveness. Alcohol boils at a much lower temperature than water, and it is this fact that makes it possible to separate it, by distillation, from the aqueous solutions in which it originally is formed. Bulk for bulk it is considerably lighter than water, and mixtures of alcohol and water show fairly regular increases in weight, per unit of volume, in proportion to the percentages of water which they contain. Because of this relation the alcoholic strength of any such mixture can be determined by means of an appropriately graduated alcoholmeter. The strength of alcohol solutions may be stated in percentages by volume or by weight, or in United States proof degree, one such degree corresponding to one-half of 1 per cent of alcohol in volume.

Chemists employ the formula C_2H_5OH to denote the composition of alcohol. This signifies that one molecule, or unit, of the compound substance alcohol is made up of two atoms, or units, of the element carbon (written C), six atoms of the element hydrogen (written H), and one atom of the element oxygen (written O). The percentage composition of alcohol is—carbon (C) 52.12 per cent, hydrogen (H) 13.13 per cent, and oxygen (O) 34.75 per cent.

Denatured Alcohol

On account of the intoxicating powers of alcohol, its manufacture is prohibited in many communities, and throughout nearly all of the civilized world its production is hedged about with restrictions in the form of excise laws, which, in addition to producing revenue, raise its price to the consumer and tend to diminish its consumption in the form of beverages. However, this increase in cost, due to tax imposition, interferes seriously with the

use of alcohol for fuel and for many other legitimate industrial purposes; and therefore many governments have enacted laws which authorize its manufacture, sale, and use for industrial ends, tax free, upon the condition that it shall first be made unfit for beverage use by the addition of materials which will give it a thoroughly foreign and nauseating odor and taste without making it dangerously poisonous or interfering with the particular industrial purpose for which it is intended. Alcohol which thus has been made unfit for drinking, is called "denatured alcohol." The materials which are used to make it unpotable, whatever their particular nature, are called "denaturants," and the process by which they are dissolved in or mingled with the original potable alcohol is called "denaturing." Some of these materials and the methods of their employment are discussed on page 15.

The Denatured Alcohol Law

On June 7, 1906, an act of Congress was approved which provided for the withdrawal from bond, tax free, of domestic alcohol when rendered unfit for use as a beverage or as an ingredient of medicines by mixture with suitable denaturing materials. The act reads in part as follows:

Be it enacted by the Senate and House of Representatives of the United States of America in Congress assembled, That from and after January first, nineteen hundred and seven, domestic alcohol of such degree of proof as may be prescribed by the Commissioner of Internal Revenue, and approved by the Secretary of the Treasury, may be withdrawn from bond without the payment of internal-revenue tax, for use in the arts and industries, and for fuel, light, and power, provided said alcohol shall have been mixed in the presence and under the direction of an authorized Government officer, after withdrawal from the distillery warehouse, with methyl alcohol or other denaturing material or materials, or admixture of the same, suitable to the use for which the alcohol is withdrawn but which destroys its character as a beverage and renders it unfit for liquid medicinal purposes; such denaturing to be done upon the application of any registered distillery in denaturing bonded warehouses

specially designated or set apart for denaturing purposes only, and under conditions prescribed by the Commissioner of Internal Revenue with the approval of the Secretary of the Treasury.

The character and quantity of the said denaturing material and the conditions upon which said alcohol may be withdrawn free of tax shall be prescribed by the Commissioner of Internal Revenue, who shall, with the approval of the Secretary of the Treasury, make all necessary regulations for carrying into effect the provisions of this act.

Distillers, manufacturers, dealers, and all other persons furnishing, handling, or using alcohol withdrawn from bond under the provisions of this act shall keep such books and records, execute such bonds and render such returns as the Commissioner of Internal Revenue, with the approval of the Secretary of the Treasury, may by regulation require.

Such books and records shall be open at all times to the inspection of any internal revenue officer or agent.

SEC. 2. That any person who withdraws alcohol free of tax under the provisions of this act and regulations made in pursuance thereof, and who removes or conceals same, or is concerned in removing, depositing, or concealing same for the purpose of preventing the same from being denatured under governmental supervision, and any person who uses alcohol withdrawn from bond under the provisions of section one of this act for manufacturing any beverage or liquid medicinal preparation, or knowingly sells any beverage or liquid medicinal preparation made in whole or in part from such alcohol, or knowingly violates any of the provisions of this act, or who shall recover or attempt to recover by redistillation or by any other process or means, any alcohol rendered unfit for beverage or liquid medicinal purposes under the provisions of this act, or who knowingly uses, sells, conceals, or otherwise disposes of alcohol so recovered or redistilled, shall on conviction of each offense be fined not more than five thousand dollars, or be imprisoned not more than five years, or both, and shall, in addition, forfeit to the United States all personal property used in connection with his business, together with the buildings and lots or parcels of ground constituting the premises on which said unlawful acts are performed or permitted to be performed: *Provided*, That manufacturers employing processes in which alcohol, used free of tax under the provisions of this act, is expressed or evaporated from the articles manufactured, shall be permitted to re-

cover such alcohol and to have such alcohol restored to a condition suitable solely for reuse in manufacturing processes under such regulations as the Commissioner of Internal Revenue, with the approval of the Secretary of the Treasury, shall prescribe. * * *

It will be seen that this law provided only for denaturing such alcohol as had been made in distilleries subject to the full regulations of the Bureau of Internal Revenue (1) and deposited in the warehouses of such distilleries. Contrary to general expectation, it did nothing toward facilitating manufacture on a small scale in such agricultural distilleries as are operated very generally in Europe. However, in the following year an amendatory act was passed (approved March 2, 1907) which was intended in part to remedy this defect in the original law. The text of this amendment is as follows:

Be it enacted by the Senate and House of Representatives of the United States of America in Congress assembled, That notwithstanding anything contained in the act entitled "An act for the withdrawal from bond tax free of domestic alcohol when rendered unfit for beverage or liquid medicinal uses by mixture with suitable denaturing materials," approved June seventh, nineteen hundred and six, domestic alcohol when suitably denatured may be withdrawn from bond without the payment of internal revenue tax and used in the manufacture of ether and chloroform and other definite chemical substances where said alcohol is changed into some other chemical substance and does not appear in the finished product as alcohol: *Provided*, That rum of not less than one hundred and fifty degrees proof may be withdrawn, for denaturation only, in accordance with the provisions of said act of June seventh, nineteen hundred and six, and in accordance with the provisions of this act.

SEC. 2. That the Commissioner of Internal Revenue, with the approval of the Secretary of the Treasury, may authorize the establishment of central denaturing bonded warehouses, other than those at distilleries, to which alcohol of the required proof may be transferred from distilleries or distillery bonded warehouses without the payment of internal revenue tax, and in which such alcohol may be stored and denatured. The establishment, operation, and custody of such warehouses

(1) Regulations and instructions concerning the tax on distilled spirits. United States Internal Revenue, No. 7, revised.

shall be under such regulations and upon the execution of such bonds as the Commissioner of Internal Revenue, with the approval of the Secretary of the Treasury, may prescribe.

SEC. 3. That alcohol of the required proof may be drawn off, for denaturation only, from receiving cisterns in the cistern room of any distillery for transfer by pipes direct to any denaturing bonded warehouse on the distillery premises or to closed metal storage tanks situated in the distillery bonded warehouse, or from such storage tanks to any denaturing bonded warehouse on the distillery premises, and denatured alcohol may also be transported from the denaturing bonded warehouse, in such manner and by means of such packages, tanks or tank cars, and on the execution of such bonds, and under such regulations as the Commissioner of Internal Revenue, with the approval of the Secretary of the Treasury, may prescribe. And further, alcohol to be denatured may be withdrawn without the payment of internal revenue tax from the distillery bonded warehouse for shipment to central denaturing plants in such packages, tanks and tank cars, under such regulations, and on the execution of such bonds as may be prescribed by the Commissioner of Internal Revenue, with the approval of the Secretary of the Treasury.

SEC. 4. That at distilleries producing alcohol from any substance whatever, for denaturation only, and having a daily spirit-producing capacity of not exceeding one hundred proof gallons, the use of cisterns or tanks of such size and construction as may be deemed expedient may be permitted in lieu of distillery bonded warehouses, and the production, storage, the manner and process of denaturing on the distillery premises the alcohol produced, and transportation of such alcohol, and the operation of such distilleries shall be upon the execution of such bonds and under such regulations as the Commissioner of Internal Revenue, with the approval of the Secretary of the Treasury, may prescribe, and such distilleries may by such regulations be exempted from such provisions of the existing laws relating to distilleries as may be deemed expedient by said officials.

The amendment in effect created a class of distilleries in which alcohol may be made for denaturation only, in quantities not exceeding 100 proof gallons daily. In accordance with its provisions, revised regulations were issued by the Bureau of Internal Revenue on July 7, 1907 (1) which interpret the law very liberally, relieving such small distilleries of many

restrictions placed upon the operation of larger establishments, and making it possible to produce denatured alcohol on a small scale, provided that the economic conditions prevailing in any given locality are such as to make this production profitable. Further reference to the substance of these regulations is made on page 28. (Government control of small denatured alcohol distillery.)

Denaturants and Denaturing

In order to insure the use of suitable materials for denaturing, the law authorizes the Commissioner of Internal Revenue to prescribe the character of the denaturing materials and the manner in which they shall be employed; and in accordance with this provision a list of denaturants for both general and special purposes has been issued, giving directions for their use and tests for determining their quality or fitness for such use. Among the substances mentioned therein are the following: Wood alcohol, benzin, pyridin bases, camphor, castor oil, caustic soda, nicotine, ether, and acetone. Indiscriminate use of these materials is not allowed. Most of them are to be used only in the manufacture of "specially denatured alcohol," the sale and use of which are permitted only under special restrictions. In making "completely denatured alcohol," the variety which may be bought freely by the public at druggists' and paint shops, only wood alcohol, benzin and pyridin may be used. On account of the relatively high price of the pyridin bases, and of the fact that the specifications for "approved benzin" admit the use of an inexpensive petroleum distillate, the following formula is altogether employed at present in making completely denatured alcohol in the United States:

To every 100 parts by volume of ethyl alcohol of the desired proof (not less than 180°) there shall be added 10 parts by volume of approved methyl alcohol and $\frac{1}{2}$ of 1 part of approved benzin.

It is prescribed in the internal revenue regulations that every industrial distillery of the class herein considered must have a special alcohol room with cisterns for storing the product of the

distillery. In case the distiller intends to denature this product on the distillery premises, he is obliged also to furnish this room with the following apparatus: A weighing tank, which is to be used for gauging alcohol and for no other purpose; tanks for the storage of approved denaturants; sealed measures, for use with the denaturants; a mixing tank, and, if desired, tanks for the storage of denatured alcohol. The labor required in denaturing is furnished by the distiller and his employees, but is carried on under the supervision of a United States gauger assigned for this purpose and in his presence.

Materials Which May Serve As Sources of Alcohol

General Considerations

The first essential in the character of a material which is to serve as a source of alcohol is that it shall contain either fermentable sugar or some component which can be transformed readily into a fermentable sugar. This is absolutely necessary, as without sugar no alcohol can be produced. A second essential is that the proportion of sugar, or its equivalent, in the proposed raw material, shall be sufficient to pay for handling the latter. This is very important, for there are many saccharine materials, such as tomatoes and unripe watermelons, the juices of which contain so small a percentage of sugar that all the alcohol obtained would be insufficient to pay for the mere cost of handling. A third requisite is that there shall be an abundant, concentrated, and stable supply of the material. Abundance is an essential, because even a small distillery will use a large amount of material daily. Thus, a plant having an approximate daily capacity of 100 gallons, or two barrels of denatured alcohol, will consume the following amounts of raw material: Two hundred gallons of rich molasses; or one ton of shelled corn; or four tons of potatoes, containing about 15 per cent of starch; or seven to eight tons of sweet apples, containing about 12 per cent of sugar. A concentrated supply of material is necessary for if it be scattered over a wide area and must be gathered by hand, the

cost for labor becomes prohibitive. The supply must be constant, for it does not pay to build a factory that can be run only at intervals. For example, ripe peaches would undoubtedly be worth distilling in localities where they are grown abundantly and where there are surplus crops, if it were not for the fact that there may not be a surplus more than two years out of five, and that the crop would have to be worked up within the short space of two or three weeks to keep it from spoiling. No distillery could earn the interest on its investment running two months out of five years.

In addition to the points enumerated, other considerations present themselves: Whether the material in question will stand transportation and storage; whether it can be worked with appliances which are to be obtained readily in this country; whether it can be handled by the machinery which is adapted to the bulk of the available material in any given region, or must have special machinery installed to fit it for fermentation, whether it possibly may yield a greater profit if used for some other purpose than distilling, and so on.

Chemical Composition of Fermentable Materials

Knowledge of the chemical composition of a proposed raw material is always essential in determining its availability as a source of alcohol. The proportion of sugar or other fermentable substance which may be present has been mentioned already as being of prime importance. In addition thereto the percentages of water, ash, crude fiber, and nitrogenous compounds or proteids will always be of interest since the proportions of these components will determine the manner in which a material must be worked. The fat percentage has little interest for a distiller, save perhaps as it may affect the feeding value of the distillery refuse; but it will be stated whenever possible, for the sake of completeness, in such analyses as are given. It may be said in this connection that the five components just mentioned—water, ash, fiber, proteids, and fat—are always determined and reported as such, but, un-

fortunately, the fermentable substances—sugar, starch, etc.—are often not determined individually, but are combined and reported as “nitrogen-free extract,” the percentage of which is obtained by subtracting the sum of the other components from 100. The value thus obtained for “extract” will of course include not only the sugar and starch, but also the unfermentable pentosans and the sum of the errors made in determining the percentages of the first five components. For these reasons the fermentable material actually present may be lower than the figures for nitrogen-free extract or carbohydrates would indicate, as from 5 to 10 per cent of this extract may be unfermentable. Whenever possible, representative analyses have been used showing the amount of starch, sugar, and unfermentable pentosans as individually determined and not as found by subtraction.

Saccharine Materials

Agave—Different species of this plant are used in the Southwest in the preparation of several varieties of distilled alcoholic liquors, and at least one distillery has been erected in the hope of utilizing them as a source of industrial alcohol. It is known that the juice of these plants contains large amounts of sugar at times, and there is every reason to believe that, with proper technical direction, they can be used profitably for industrial purposes.*

Fruits—The average amount of sugar contained in some of the common fruits is shown in the following tabulation:

	Average percentage of total sugars, calculated as dextrose.
Apple	12.2
Banana	13.8
Grape	15.0
Orange	5.4
Peach	7.6
Pear	10.0
Pineapple	11.7
Prickly pear	4.2
Tomato	2.0
Watermelon	2.5

* A sample of one of these plants, sotol (*Dasyllirion texanum*), was analyzed in the Bureau of Chemistry and found to yield 16 per cent of levulose.

It must not be supposed, however, that it is practicable to obtain all of the sugar in these fruits in a form suitable for fermentation. It would be necessary, in preparing any of them for distillation in a column still, to express the juice from the marc, since the latter, if allowed to enter the still would impede its working, and obviously a certain proportion of the juice and of the sugar will remain in the marc.

Thus it is estimated that it would be impossible, in working with apples, to obtain more than 75 per cent of the total fermentable material, or about 9 per cent of the the weight of apples delivered. On this basis, a ton of average apples should yield about 14 gallons of alcohol. Estimating the cost of gathering culls and windfalls, and of delivering them at the mill, to be \$4 per ton, a figure based on actual experience, the raw-material expense for a gallon of alcohol will be at least 28 cents.

In the case of grapes, assuming that approximately 80 pounds of juice may be expressed from 100 pounds of Concord, and that this juice contains 18 per cent of total sugars, a ton of fruit should yield between 21 and 22 gallons of alcohol. If the expense of picking and hauling grapes to the distillery is placed at \$6 or \$7 a ton, a figure obtained from a grape-growing district in California—the cost of raw material for a gallon of alcohol will be 30 cents.

In the case of watermelon, if a 90 per cent extraction of juice containing 2.5 per cent of sugars is obtained, a ton of melons will yield about three and one-half gallons of alcohol. If the cost of gathering and hauling the fruit is set at \$2 per ton, the raw-material cost will be not less than 50 cents per gallon of alcohol.

In these three specific cases, it has been assumed that the fruit itself was valueless on the spot where grown, and that it could be delivered at the distillery for the mere cost of gathering and hauling. Even on that basis, it would be too costly to use as raw material in making industrial alcohol. The fact that fruit

is extensively used in the manufacture of wines and brandies, has no bearing on the present discussion for the reason that the value of potable liquors bears but little relation to the amounts of alcohol which they contain, but is governed almost entirely by the qualities of their flavors and aromas.

Molasses—Beet molasses, a refuse from the manufacture of beet sugar, is used on a very large scale abroad, and in several distilleries in the country, as a raw material for alcohol production. Usually, it contains about 50 per cent of sugar, and it generally needs only to be diluted and acidified to prepare it for fermentation. Sometimes a lot will not ferment readily, but generally it is worked without any difficulty. A ton should yield from 75 to 80 gallons of alcohol. At \$15 per ton, the raw material for a gallon of alcohol will cost 19 or 20 cents.

Cane molasses contains usually about 25 per cent of water, 20 per cent of non-saccharine solids, and 55 per cent of sugars. The following figures show the composition of two samples of typical distillery molasses of different origins, one being a Louisiana blackstrap and the other a Porto Rican molasses.

Analyses of Two Typical Kinds of Molasses

Determination	Porto	
	Louisiana Per cent	Rican Per cent
Water	23.5	24.3
Sucrose	26.6	35.8
Reducing sugars	29.1	18.3
Nonsugars	20.8	21.6
Total	100.0	100.0

Almost invariably cane molasses needs only to be diluted and yeasted to enter into vigorous fermentation. It is common, however, for molasses distillers to add a certain amount of acid to the fermenting solutions to prevent bacteria from invading them and setting up false fermentations. In some cases sulphuric acid is used for this purpose, as in the beet molasses distilleries, but it is equally common, and probably wiser, to use sour distillery slop to produce the desired acidity. A ton of molasses, having the composition of the Louisiana

sample given in the table, will have a volume of about 173 gallons and yield approximately 85 gallons of alcohol. At three cents per gallon, for which such molasses could be bought only a few years ago, the cost of the material for a gallon of alcohol would be little over six cents. The increasing utilization of molasses as a feeding stuff has advanced its price to from 6 to 10 cents, but at some plantations it is probably still cheap enough to retain its old position as a most advantageous raw material for the distiller.

Sorghum—A large number of analyses made in the Bureau of Chemistry* indicates that the juice of saccharine sorghum has the following average composition:

	Per cent
Water	81.4
Sucrose	12.7
Reducing sugars	1.1
Undetermined solid matters.....	4.8
Total	100.0

With a light horse-driven mill, about 60 per cent of the weight of the topped and cleaned cane can be obtained in the form of juice. With a heavy mill, such as is used in cane-sugar manufacture, an extraction of at least 75 per cent should be obtained. An extraction corresponding to 65 per cent of the weight of the cleaned stalks may, therefore, be considered a fair average. On this basis a yield of about 14 gallons of 180-degree alcohol per ton of cleaned stocks would be obtained. If the latter could be delivered at the distillery at a cost of \$3 per ton, the material for a gallon of alcohol would represent a value of about 21 cents. A relatively slight improvement in the quality of the juice and in the extraction would lower the cost of material per unit of production very much. Thus, 1,000 pounds of the juice of the Colman sorghum, containing 14.42 per cent of sucrose and 1.10 per cent of reducing sugars, should yield about 12¼ gallons of 180-degree alcohol. The yields of alcohol to be expected from a ton of cleaned Colman stalks, and the cost of

* U. S. Department Agriculture, Division of Chemistry, Bulletin 34, pp. 23 *et seq.*

material per gallon of spirit, are shown in the following tabulation for different degrees of juice extraction.

**Yields of Alcohol From Sorghum Stalks
With Varying Degrees of Juice
Extraction**

Proportion of juice extracted from stalks	Yield of 180° alcohol per ton of cleaned stalks	Cost of material per gallon
Per Cent	Gallons	Cents
65	15.92	18 85
70	17.15	17 50
75	18 35	16 35

Since the gums and slimy bodies contained in sorghum juice do not interfere in the least with its fermentation, and the plant can be grown readily over a very wide range of territory, it is plain that the material deserves favorable consideration in connection with the manufacture of alcohol, and that it is likely to be utilized in the future in this way.

Sugar Beets—The following figures relative to the composition of the sugar beet may be considered as a representative analyses: (1)

Water	Per cent. 81.51
Ash	.62
Protein	1.72
Fiber	1.35
Fat	.07
Carbohydrates	14.73
Total	100.00

The records of several experimental fields cultivated at the agricultural experiment stations in California, Colorado, Michigan and Wisconsin show sugar percentages running from 13 to 16. Fourteen per cent will probably be a fair commercial average for the content of fermentable material in sugar beets as grown at present.

In France, where the beet has been used extensively as a source of alcohol, it has been found necessary to extract the juice for fermentation, using one of the extraction methods employed in the sugar factories. The pulp, while it offers no obstacle to fermentation, forms a jelly on heating which interferes seriously with

distillation. Data obtained from the results of actual distillery yields show that for every 100 pounds of sugar contained in the beets entering the French distilleries, seven and one-tenth gallons of absolute alcohol were produced, equivalent to eight gallons at 180-degree proof, which is the minimum strength used in this country for denaturing purposes.

With beets at \$4.75 to \$5 per ton, the price commonly paid by sugar factories in this country, and a sugar content of 14 per cent, the raw material needed to produce a gallon of 180-degree alcohol would represent a value of 22 cents. Under present conditions this probably would be a prohibitive price, but the time may come when beets will be used as a source of alcohol in the United States as they are in Europe.

Sugar Cane—Spencer gives the following figures as the average of about 40 cane-juice analyses made at the Magnolia Plantation, Louisiana:

	Per cent.
Water	83.6
Sucrose	14.1
Reducing sugars	.6
Undetermined solids	1.7
Total	100.0

On the presumption that 72 per cent of the total weight of the sugar cane can be obtained by two pressings, as juice of this composition, a ton of cane should yield 16.7 gallons of alcohol. If cane is worth from \$3 to \$3.25 at the factory, this would make the cost of the raw material for the alcohol about 19 cents per gallon.

Sugar-corn Cannery Wastes—The stalks of the sugar corn contain quite large amounts of sugar analyses made in the Bureau of Chemistry having disclosed its presence in proportions varying between 7 and 15 per cent. Investigations conducted at a corn cannery in Illinois, in 1906, showed that the waste stalks amounted to about 40 per cent of the total weight of corn brought to the factory, and that it was possible to produce from them from 6 to 10 per cent of alcohol, with a safe average of 8 per cent. On this basis about 11 gallons of alcohol should be re-

(1) Twelfth Annual Report Indiana Agricultural Experiment Station, 1899, p. 71.

covered for every ton of corn delivered to the cannery. Unfortunately, the season during which these stalks are suitable for utilization in the manufacture of alcohol is very limited, and probably it would not pay to put up a distillery to handle them, unless other cheap materials were available for use during the rest of the year.

Starchy Materials

Certain materials contain an essential part of their fermentable material in the form of starch, even though some of them, like artichokes and sweet potatoes, also contain notable amounts of sugar. They differ from the saccharine materials, in requiring to be "mashed" before they can be fermented. This operation is discussed in detail below.

Grains

Barley—The average composition of ordinary six-row barley is approximately as follows:

	Per cent.
Water	8.7
Ash	3.0
Protein	11.9
Fiber	5.8
Fat	2.0
Starch	58.9
Pentosans	9.6
Total	99.9

On account of its expensiveness, barley is never used by itself as a source of industrial alcohol. It is, however, used in large quantities in making malt, which operation is described on page 25. The composition of a typical malt is as follows:

	Per cent.
Water	5.9
Ash	2.7
Protein	11.5
Fiber	6.0
Fat	2.1
Starch	48.4
Sugars	12.2
Pentosans	10.6
Total	99.4

It is customary to use about eight pounds of malt to saccharify 100 pounds of raw grain. Two pounds will be sufficient for mashing 100 pounds of potatoes.

Maize (Indian Corn)—The following figures represent the average of a large number of analyses taken mostly from the work of the Illinois experiment station:

	Per cent.
Water	10.0
Ash	1.5
Protein	10.4
Fiber	1.9
Fat	5.2
Pentosans	5.0
Sugars	2.0
Starch	64.0
Total	100.0

A lot of distiller's corn (yellow dent) used in the experimental distillery of this department, and analyzed in the Bureau of Chemistry, was found to contain 72.8 per cent of nitrogen-free extract, including 57.9 per cent of starch and 2.3 per cent of sugars, in addition to pentosans, gums, etc.

The method of working this and other grains is described on pages 23 to 27. One ton of grain, made up of 1,850 pounds of maize and 150 pounds of malt of the compositions given above, should yield 100 gallons of 180-degree alcohol. At 50 cents a bushel for corn and 65 cents a bushel for the barley necessary to make the malt, the ton of grain will cost about \$19, and the cost of raw grain per gallon of alcohol, will be 19 cents.

Maize is, and always has been, the chief source of industrial alcohol in this country. The ease with which it is raised, its ability to stand transportation and storage, and its low price in past years, have combined to give it a preeminence as a distiller's raw material, which it undoubtedly will retain for many years.

Oats—This grain, which contains about 50 per cent of fermentable material and which might with care be made to yield about 70 gallons of alcohol per ton, is unsuited to distillery use on account of its greater value as a feeding stuff, and the glutinous nature of the mixture which is formed when it is treated with hot water.

Rye—A lot of this grain used in the experimental distillery had the following composition:

	Per cent.		Per cent.
Water	9.4	Water	10.5
Ash	2.1	Ash	1.9
Protein	10.7	Protein	11.5
Fiber	1.9	Fat	2.0
Fat	1.9	Fiber	2.3
Starch	53.7	Sugars	2.8
Sugars	5.6	Pentosans	7.0
Pentosans, gums, etc.....	14.7	Starch, etc.....	62.0
	<hr/>		<hr/>
Total	100.0	Total	100.0

This material is used very largely in distilleries which produce compressed yeast or rye whisky, and it sometimes is employed in small amounts in the yeast mashes of alcohol distilleries, but it is not suitable for use as the chief ingredient of the mash in an alcohol distillery on account of its expensiveness and though containing about 60 per cent of fermentable matter it rarely yields over 85 gallons of alcohol to the ton.

Sorghum seed—This grain, regarding which many inquiries are made, has the following average composition, closely resembling that of maize:

Comparison of Sorghum Seed and Kafir Corn

Determination	Sorghum Seed Per cent	Kafir Corn Per cent
Water	8.3	12.5
Ash	1.8	1.3
Protein	13.3	10.9
Fiber	1.5	1.9
Fat	3.0	2.9
Pentosans	4.3
Sugars	1.5
Nitrogen-free extract.....	66.3	70.5
	<hr/>	<hr/>
Total	100.0	100.0

Undoubtedly sorghum seed could be worked in the distillery as corn is and probably would require less cooking and give fully as good a yield, though its use for this purpose has never been tested as far as the writer knows.

Wheat—What has been said regarding the yield of alcohol to be obtained from rye applies in a general way to wheat also. Although wheat contains nearly 65 per cent of starch and sugars, it is too expensive to be used for alcohol production unless frozen or for other reason unavailable for food purposes.

Roots

Artichoke—The tuber of the Jerusalem artichoke has the following average composition:*

	Per cent.
Water	79.0
Ash	1.0
Protein	1.3
Fiber8
Fat2
Pentosans	1.2
Nitrogen-free extract	16.5
	<hr/>
Total	100.0

It is seen that artichokes contain from 16 to 18 per cent of fermentable matter in the form of levulose and inulin, and as the latter may be converted into the former without the use of malt, by merely boiling under pressure, it can be worked very cheaply. When 17 per cent of fermentable substance is present, a ton should yield about 25 gallons of alcohol; and as it can be raised and delivered for about \$5 per ton the raw material for a gallon would cost about 20 cents. The tuber has remarkably good keeping qualities and deserves far more attention than it has yet received as a distiller's material.

Cassava—The root of the sweet cassava has the following average composition:

	Per cent.
Water	65.0
Ash7
Protein9
Fiber	1.7
Fat3
Starch	25.4
Nitrogen-free extract	6.0
	<hr/>
Total	100.0

It is fair to assume that about 80 per cent of the dry matter of the root, or about 28 per cent of the weight of the

* 1 Behrend, J. Landw., 1904, 52:127.

root itself, is fermentable. On this assumption a ton of roots should produce about 42 gallons of alcohol. At \$5 per ton, which would be a fair price with modern methods of cultivation, the raw material would cost about 12 or 13 cents per gallon of alcohol. That technical difficulties might arise in handling it is very possible, but the analytical data and cost afford every reason for testing the value as a source of alcohol.

Potatoes—Following is the average composition of Maine potatoes, as determined a few years ago in the Bureau of Chemistry:

	Per cent.
Water	77.0
Ash9
Protein	2.2
Fiber7
Fat1
Starch	18.3
Sugars, etc., by difference.....	.8
Total	100.0

Samples analyzed more recently in connection with the work of the experimental distillery were found to contain about 15 per cent of starch and 0.4 per cent of sugars. Liquid wastes from starch factories in Maine were also examined, but did not contain sufficient fermentable material to be of value for alcohol production.

The method of working potatoes is discussed at length in Farmers' Bulletin 410. For every per cent of starch contained in potatoes they should yield about 1.6 gallons of alcohol per ton. If the tubers contain 16 per cent of starch, a ton should yield over 25 gallons of alcohol; and if they can be delivered at the distillery for \$5 per ton, a fair price for culls in potato-growing regions, the raw material for a gallon of alcohol will cost about 20 cents.

In Germany the potato is almost the only material used as a source of industrial alcohol, not only because it offers a cheap raw material, but because it is highly advantageous from an agricultural point of view. It undoubtedly will be similarly utilized in this country in the future.

Sweet potatoes—The following average data are based on work done at the South Carolina station (1) and may be considered as representing sweet potatoes of good quality:

	Per cent.
Water	66.0
Ash	1.0
Protein	1.5
Fiber	1.3
Fat5
Sugars	5.5
Starch	21.8
Undetermined material	2.4
Total	100.0

These roots are seen to contain about 27 per cent of fermentable substances, of which approximately one-fifth is sugars. In storage there is a decrease in the starch percentage and a corresponding increase in that of sugar.

Preliminary experiments conducted at the Bureau of Chemistry indicate that the sweet potato can be mashed in about the same way as the common potato. Undoubtedly there will be some slight destruction of sugar on heating under pressure, but it ought not be such as to cause a serious loss. It does not appear that the somewhat fibrous character of the root interferes with steaming it in an apparatus built for potatoes.

A ton of sweet potatoes, containing about 27 per cent of fermentable substances and costing \$8, should yield approximately 38 gallons of alcohol at a cost of about 21 cents a gallon for raw material.

Manufacture of Alcohol Historical Note

Although there are processes by which alcohol may be made synthetically in the laboratory, they are too complicated and expensive to have any practical manufacturing value. Therefore the method which has been used for many centuries, namely, the distillation of fermented-sugar solutions, is still employed in alcohol production. This manufacturing process is very ancient, having been used probably as early as 800 B. C. It seems for many centuries to have been employed

(1) South Carolina Bulletin 136, 1908, p. 11.

only in preparing spirituous beverages of somewhat higher alcoholic strength than could be obtained by fermentation alone. The first stills were very crude and simple in design, and were incapable of producing distillates of great strength from the wine which invariably was used as the material for distillation. It was indeed found by the early chemists that if the first weak distillate was subjected to a second and third distillation its alcoholic strength could be raised (though at the expense of a material diminution in its volume) to such an extent that it would burn, but the expensiveness of the product thus obtained was too great to allow its use for any industrial purposes.

At present wine and other fermented fruit juices are distilled only for the production of potable spirits; and industrial alcohol is made altogether by the distillation of fermented saccharine solutions which are prepared either directly from raw materials containing sugar, such as molasses, or from starchy materials like potatoes or the cereal grains, after a preliminary treatment which converts their starch into sugar.

Theory of Alcoholic Fermentation

The process of alcoholic fermentation is established whenever yeast is allowed to act on sugar solutions of moderate strength at temperatures between 50 degrees and 90 degrees Fahrenheit. Theoretically the process consists of a simple splitting up of sugar into alcohol and carbonic acid gas, any given amount of sugar yielding proportionate and perfectly definite amounts of these two products of its decomposition. This is illustrated in the following example:

The chemical composition of dextrose, which is the form of sugar occurring in most ripe fruits, is represented by the formula $C_6H_{12}O_6$, which signifies that one molecule or unit of the compound substance dextrose is made up of six atoms or units of the element carbon, 12 of the element hydrogen, and six of the element oxygen. When fermentation takes place, the molecule of dextrose breaks up substantially as is indicated by the following equation:

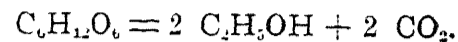

This signifies that after fermentation is over the dextrose will have disappeared and in its place will be found an amount of alcohol containing all the hydrogen, two-thirds of the carbon, and one-third of the oxygen of the sugar, and an amount of carbon dioxid containing one-third of its carbon and two-thirds of its oxygen. Theoretically the total weights of the alcohol and carbon dioxid which are produced in the fermentation should equal exactly the weight of dextrose which is decomposed, and 100 pounds of the sugar should yield 51.11 pounds of alcohol and 48.89 pounds of carbon dioxid.

In practice, however, the decomposition is never complete, nor is it ever so simple as is indicated by the foregoing equation. Only in carefully conducted laboratory work is it ever possible to ferment any sugar completely; and even then, as a result of life processes of the yeast which are not yet understood by chemists or biologists, small and varying proportions of sugar escape transformation into alcohol, and are converted instead into other substances. According to the investigations of Pasteur, 100 pounds of dextrose, instead of yielding the theoretical weights of alcohol and carbonic acid indicated by the equation, will produce in laboratory practice the following amounts of fermentation products:

Alcohol	Pounds. 48.55
Carbon dioxid	46.74
Glycerin	3.23
Organic acids62
Miscellaneous	1.23
Total	100.37

The fact that the total weight of the fermentation products exceeds slightly the weight of sugar fermented is explained on the ground that the formation of certain of the by-products is accompanied by the absorption and fixation of slight amounts of water.

In manufacturing work, such completeness of fermentation may be taken as an ideal toward which one is to strive. According to the skill of the distiller, the character of his mechanical equipment,

and the quality of his water, yeast, and fermentable materials, his yields of alcohol may approximate those indicated or may, on the other hand, fall far below it.

Nature of Yeast

Yeast, the exciting agent of the alcoholic fermentation, is familiar to the general public chiefly in the form of the small square cakes which are sold at groceries, and to workers in breweries and distilleries as a more or less frothy paste. Whatever its outward form and appearance may be, it always is made up of innumerable microscopic plants which are globular or ovoid in form, approximately 1/4000 inch in diameter, and fairly colorless and transparent as seen under the microscope. Yeast withstands prolonged exposure to cold without serious injury, but is weakened rapidly when kept at high temperatures, and is killed quickly when heated to about 110 degrees Fahrenheit. It ordinarily reproduces itself by a process of budding, and grows at the expense of various nutrient materials, such as lime, potash, phosphoric acid, and nitrogenous compounds, which it absorbs from the solutions in which it is placed. The vigor of a fermentation seems to depend largely upon the phenomenon of yeast growth. Good fermentation can not be established without abundant and suitable nutrients for the yeast and its vigorous development.

The selection of a suitable yeast for any purpose and its preparation and maintenance in a pure and vigorous condition are arts which demand thorough training and experience. They can not be learned from books alone and call for no small amount of manipulative skill.

Preparation of Saccharine Solutions for Fermentation

Certain saccharine materials, such as the juices of most fruits and of the sugar cane, are in their natural condition so susceptible to fermentation that they can not be preserved unaltered unless they are sterilized in sealed bottles or some antiseptic or preservative material, such as salicylic acid, is added. Other sugar-containing materials, such as molasses, do

not ferment readily until they have been subjected to certain preliminary treatments. Thus, both cane-molasses and beet-molasses must be diluted with water before they can be fermented, and since they often are deficient in the nitrogen compounds which are essential to yeast production it sometimes is found necessary to add nitrogen to their solutions in the form of ammonium sulphate or some equivalent material. Furthermore, beet-molasses is usually alkaline, and as yeast will not work in alkaline solutions it is necessary to acidify beet-molasses before adding yeast to it. Diluted sulphuric acid is commonly used for this purpose. The amount of water or of chemicals which must be added to a given quantity of molasses to fit it for fermentation will depend upon the composition of the latter. Experience has shown that with ordinary cane-molasses it is desirable to use about six volumes of water for one of molasses. In this way a solution is obtained which contains about 12 per cent of sugar and is capable of producing approximately 6 per cent of alcohol. This proportion of sugar has been found, in general, to give the best results with regard to the rate, completeness, and economy of fermentation.

Preparation of Fermentable Solutions from Starchy Raw Materials

While the saccharine raw materials of the fermentation industries can be prepared for use by the relatively simple processes of solution or juice expression, such materials as potatoes and grain, which contain little sugar and much starch, must be subjected to special treatment in order to convert the insoluble and unfermentable starch into sugar. The series of operations by which this starch conversion is accomplished is called "mashing," and consists of a preliminary scalding or cooking process, the purpose of which is to liquify the starch, and of the saccharification proper, in which the soluble starch is converted into dextrin and sugar. The agency by which the latter conversion is accomplished is the specific action (in the presence of moisture, and at a suitable temperature) of

certain substances called enzymes, which usually are developed for this particular purpose in a portion of the grain used for mashing, by a process called malting.

Malting—When the seeds of any cereal are moistened and allowed to sprout, changes in their chemical composition take place which are fully as striking as the accompanying changes in the appearance of the grains. Most important of these is the formation of bodies which have the power, when dissolved in water and allowed to act at a suitable degree of warmth, of corroding the insoluble starch granules of the grain, of rendering them soluble, and of converting the starch ultimately into a fermentable sugar called maltose. Grain which has been treated so as to develop these bodies is called malt.

These enzymes, or active bodies of the malt, are usually grouped under the name diastase, and they appear during the sprouting of all starchy seeds. Their formation has been utilized technically in the case of several of the cereals, such as wheat, rye, oats, maize, and barley. Rye and barley produce diastase more abundantly than the other grains, and are employed in large quantities in the malting industry. Of the two, barley is most used on account of the protection which is afforded by its husk to the tender kernel of the grain during the rough handling incidental to the malting process.

In making malt the barley is cleaned thoroughly by screening and washing, and is then steeped in water until the grains have absorbed enough water to soften them thoroughly and prepare them for germination. The excess of water is then drained off, and the wet grain is spread evenly on a smooth and scrupulously clean floor in a well-ventilated room which can be kept at a temperature of about 55 degrees to 60 degrees Fahrenheit. The grain is turned frequently, with wooden shovels, to keep it uniformly moist and to prevent its overheating, and as sprouting progresses it is gradually spread over a greater floor area so that a pile which originally was from 12 to 18 inches deep may finally have a depth of only three or four inches.

Malt which is intended for shipment is usually grown for about a week at a temperature not exceeding 68 degrees Fahrenheit, after which it is dried slowly in kilns that are gradually raised from 95 degrees to 125 degrees, until only two or three per cent of moisture remains. Malt which is made in the distillery where it is to be used may be grown at about 55 degrees for three or four weeks, and should then be used without having been dried. Green malt, thus prepared, has a much higher diastatic power (1) than the dried malt of commerce.

One hundred pounds of good barley will make about 75 pounds of kiln-dried distiller's malt, which will be strong enough to saccharify about 1,000 pounds of raw grain (maize). The same barley, grown longer and used as green malt, can be made to saccharify nearly twice as much raw grain.

In converting starch into sugar, malt diastase exerts two distinct forms of chemical activity—liquefaction, and saccharification. The intensities of these activities depend largely upon the temperature at which the diastase is made to act upon the starch, and the two forms of activity are differently affected by alterations in this temperature. The liquefying power is exerted most strongly at about 158 degrees Fahrenheit, is weakened at approximately 175 degrees, and is destroyed at about 200 degrees. The saccharifying power is strongest between 120 degrees and 130 degrees Fahrenheit, is weakened seriously at 145 degrees, and is destroyed completely at 175 degrees. These facts show the need of drying distiller's malt at a relatively low temperature, and indicate the temperature limit below which saccharification must be conducted.

Mashing—The first stage of every mashing is a scalding, which gelatinizes and partially liquefies the starch of the raw materials. When this preliminary cooking has gone far enough, the mash is cooled somewhat and malt is added, whereupon the liquefaction is completed and the soluble starch is more or less com-

(1) The power of converting starch into sugar.

pletely converted into maltose. The form of the mashing apparatus and the temperatures at which the several operations are conducted are modified as may be necessary to fit the peculiarities of the raw materials.

In this country maize is the chief starchy material used in the manufacture of alcohol. It is mashed in a sort of kettle known as a vacuum cooker.

The vacuum cooker is a horizontally placed cylindrical vessel made of steel boiler plate, and has a capacity of about 40 gallons for every bushel of grain to be mashed in one charge. Just below the center of each end it is provided with stuffing boxes, through which a shaft passes. The latter carries several rakes or stirring arms inside the shell; outside it is provided with a strong toothed wheel, arranged for chain drive. Thermometers and try cocks are mounted in each end of the shell, and if the cooker is large a third thermometer is set in the middle of the side. In a row along the bottom are several small steam-inlet valves so constructed that while steam can pass freely into the cooker the contents of the latter can not run back into the steam pipe when pressure is removed outside. At the middle of the top of the cooker is a dome fitted with a pipe connection which leads to a "cross." From one side of the latter connection is made to the steam supply, which must be carried at about 50 pounds pressure; from the other side connection is made with the vacuum pump, and from the top a pipe leads to a blow-off valve. On top of the cooker, at one end, there is a manhole through which water and meal may be introduced, and in the bottom, at one end, there is a discharge valve which opens into a pipe leading to the drop tub. The operation of this cooker is as follows:

Water in the proportion of 20 to 25 gallons for every bushel of corn is first run in and is warmed up to about 120 degrees Fahrenheit. The rakes are then started and the grain, which should be ground to a coarse meal, is added slowly enough to keep it from forming lumps. When the meal is all in, the manhole is closed and

steam is turned on through the small valves in the bottom, the blow-off valve being left open. When the temperature of the mash has risen to 212 degrees the blow-off valve is closed and pressure is allowed to rise within the cooker at such a rate that the thermometers and a pressure gauge in the dome indicate a fairly constant equalization of temperature in the contents. The pressure is allowed to rise to about 50 to 55 pounds, corresponding to a temperature of about 300 degrees Fahrenheit, but is maintained at this point for a few minutes only, after which the steam is shut off and the blow-off valve is opened until the pressure is completely relieved. The blow-off valve is then closed again, and the valve between the cooker and vacuum pump is opened. Application of the vacuum causes renewed boiling and a rapid fall of temperature in the contents of the cooker, and when the thermometers read from 140 degrees to 145 degrees Fahrenheit the vacuum is released and the malt is added.

The amount of malt employed is usually about one-tenth of the weight of corn in the mash. It is ground quite fine and is mixed in the small grain tub with enough lukewarm water to make it flow freely through the pipe which leads to the cooker. The length of time allowed for saccharification in the cooker will vary from fifteen minutes to an hour, according to the temperature—which should be held between 140 degrees and 145 degrees Fahrenheit—and the amount and diastatic strength of the malt. It is advisable not to hasten this part of the mashing process unduly, and the completeness of the starch conversion should always be proved

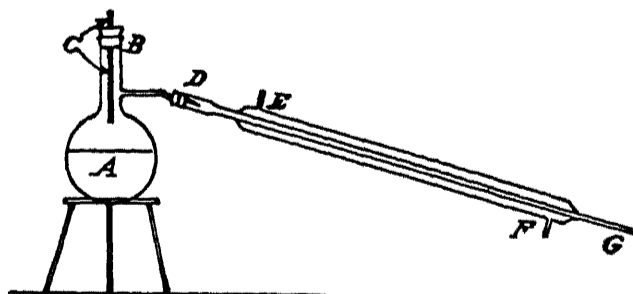

Fig. 1. Small Laboratory Still.

A, boiler or kettle of still; B, opening for filling or charging; C, thermometer, sometimes omitted; D, connection to condenser; DG, inner condenser tube, passing through EF, water jacket, with water inlet at E, and outlet at F; G, outflow for distillate.

before pumping the mash through the coolers into the fermenting cisterns.

The apparatus and mashing process described are designed primarily for use in corn distilleries, but they may be adapted with but little change to use with potatoes as a raw material. (1)

Fermentation

In order to minimize the chances for souring and spoiling, the saccharine solution intended for fermentation is pumped to the fermenting cisterns as soon as possible after its preparation. Yeast which in the meantime has been prepared (2) separately in a small tub from a mash containing malt and either rye or potatoes, is added to it at once in a proportion varying between five and ten per cent. If necessary, water is added to fill the cisterns to within a few inches of the top, and the whole volume of liquid is thoroughly plunged or mixed. At this time the solution should contain between 17 and 22 per cent of solids, as shown by a reading of 17 degrees to 22 degrees on the Balling saccharometer, and its temperature should be between 60 degrees and 65 degrees Fahrenheit.

Within a few hours gas bubbles will begin to break the surface of the fermenting liquid, forming a constantly thickening cap of foam, and the whole mass of beer will rapidly come into vigorous motion. At the same time its temperature will begin to rise, and its specific gravity, as indicated by the saccharometer, will fall. According to the temperature, the kind of material fermented, and the strength of the yeast, fermentation will be complete within from 48 to 96 hours, as will be shown by the gravity and temperature ceasing, respectively, to fall and to rise, by the solution coming to rest and losing its foamy cap, and by cessation of the escape of gas bubbles. The fermented liquor, or distiller's beer, is now said to be "dead" or "ripe," and is ready for distillation.

If the composition of the mash and the degree of fermentation are satisfactory, the beer should increase about 30 degrees

Fahrenheit in temperature above the point at which it was set its gravity should fall almost to 0 degrees Balling, and it should contain between six per cent and ten per cent of alcohol.

Distillation

The separation of alcohol from the fermented liquors in which it is formed is made possible by the fact that its boiling point, 173 degrees Fahrenheit, is lower than that of water by nearly 40 degrees Fahrenheit. On this account a mixture of alcohol and water boils at a lower temperature than water alone, and the vapors which first arise from such a boiling mixture are richer in alcohol than the liquid itself. Thus, a mixture of alcohol and water which contains eight per cent by weight of alcohol, will boil at about 200 degrees Fahrenheit, and will produce a vapor which contains approximately 43 degrees of alcohol by weight. A liquor of the latter composition will in its turn boil at about 181 degrees Fahrenheit and will form a vapor containing about 68 per cent of alcohol. When such mixtures are distilled all of their alcohol, mingled with more or less water, will pass over into the distillate, while a considerable proportion of the water still remains in the kettle of the still. It is possible, therefore, even with stills of such simple type as are outlined in Fig. 1 and Fig. 2, to obtain ultimately a fairly strong alcohol by repeated distillation of the successive distillates.

Such a still as is shown in Fig. 2 will produce in two successive distillations (singling and doubling) from 100 volumes of a beer containing approximately 10 per cent of alcohol about 37 volumes of a distillate of 67 per cent strength together with about 23 volumes of weak distillates which can be saved for subsequent redistillation. It would be impossible, however, to make any quantity of a 90 per cent distillate with such an apparatus except by incurring an expense for fuel and labor which would far exceed the highest possible industrial value of the product.

Fortunately it is possible so to construct a still that the requisite number of redistillations take place simultaneous-

(1) See Farmers' Bulletin 410, p. 11

(2) Detailed directions for making yeast are given on p. 25 of Farmers' Bulletin 410.

ly in a single apparatus with little more outlay for fuel and labor than would be required to subject the same volume of beer to a single distillation in the pot still shown in Fig. 2. Such a complex

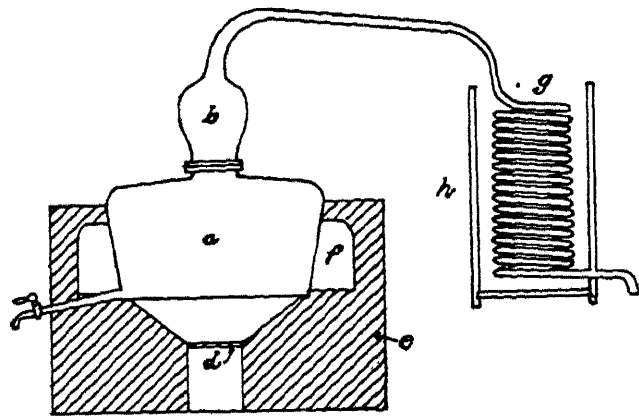

Fig. 2. Fire-pot Still.

a, Kettle of still; *b*, head of still; *c*, draw-off cock; *d*, grate; *e*, masonry support; *f*, flue; *g*, condensing worm; *h*, worm tub.

apparatus, known as a column still, costs much more to build than does a simple still of the same beer capacity, but its almost automatic action and the saving which it affords with regard to labor, fuel, and water, make it a necessary investment for any distillery which is designed to produce industrial alcohol.

Although the details may seem somewhat complicated, the actual management of a continuous still is in fact quite simple. When its operation is once well under way a condition of equilibrium is established in the working of its various parts, and as long as the supplies of water, steam, and beer are kept uniform it is possible to maintain a steady flow of distillate of practically constant proof for hours at a time, with comparatively little attention from the distiller.

Governmental Control of a Small Denatured Alcohol Distillery

Certain important features of the regulations of the Bureau of Internal Revenue are of special interest to those to whom the subject is new.

First of all, the mere possession of any still or distilling apparatus set up, even though the same is not employed in distilling alcohol, subjects its possessor or custodian to heavy penalties unless he has registered it in writing with the collector of internal revenue for the district in which it is located. The distillation of

alcohol is forbidden by law, except when conducted in accordance with the regulations issued by the Bureau of Internal Revenue and under the supervision of a designated officer, no matter how much the alcohol may be mixed or diluted with other substances. These facts are emphasized because they directly contradict the statements sometimes made that apparatus and processes can be furnished by which denatured alcohol can be made without Government supervision.

Other points worthy of mention in this connection are as follows:

Distilleries are to be constructed and their machinery is to be arranged in compliance with the regulations. (Secs. 14-24, pp. 45-50.[1])

The distiller must own or control the land on which the distillery is erected. In case that he does not own it or that it is mortgaged he must file the written consent of the owner or mortgagor to its use for distillery purposes. (Sec. 4, p. 41.)

The distiller must give written notice of his intention to engage or continue in the distilling business, stating what kinds of material he intends to use. (Secs. 5 and 13, pp. 41-42 and 45.)

The distillery, when ready for operation, must be "surveyed" by a designated Government official. (Secs. 25 and 6-12, pp. 50 and 42-45.)

Before beginning operations, the distiller must file a bond, signed by himself and two sufficient sureties, for an amount not less than the tax on all the spirit that the distillery could produce in a month. (Secs. 26-27, pp. 50-52.)

The survey having been made and the bond filed, the distiller must give notice of the day on which he will begin operations. (Sec. 29, p. 52.)

Records must be kept by the distiller, for inspection by the revenue officers, of the amounts and kinds of material received and used and of the amount of alcohol produced. (Secs. 34-37, pp. 54-57.)

No kind of spirit save alcohol for denaturing purposes can be produced at an industrial distillery. (Sec. 38, p. 57.)

(1) U. S. Internal Revenue Reg. No. 30, rev.

When a revenue officer is assigned to a distillery, it must be operated regularly on every day except Sundays. (Sec. 39, p. 57.)

Methods are prescribed by which denaturants may be obtained and used. (Secs. 41-44 and 49, pp. 58, 59, and 61.)

Factors Influencing the Cost of Manufacturing Alcohol

While cheap and abundant raw material is indeed essential to the profitable production of denatured alcohol, there are other factors, no less important, which enter into the cost of manufacture. Some of these are as follows:

Interest and depreciation—A small distillery can hardly be built and equipped for less than \$12,000. Interest on the investment may therefore be set at about \$700 a year; and a like amount ought to be allowed for keeping the plant in good working order. The capacity of such a plant can be doubled without any very great increase in cost; and if the capacity be halved, the reduction in cost will be relatively small.

Labor—At least three and probably four men will be needed to run any distillery, however limited its capacity. Increase of the production up to 400 or 500 proof gallons daily would probably not call for additional labor. Five men undoubtedly could handle a plant producing 1,000 gallons daily.

Water—A large amount of pure cold water is needed for the operation of a distillery. This fact is generally unknown save to those who are engaged in the distilling business. A plant capable of producing 100 proof gallons, or 55 gallons of 180-degree alcohol, in a working day of ten hours, will need a supply of water amounting to not less than 3,000 gallons in that length of time, five gallons per minute, and may demand considerably more.

Fuel—Little definite information is available regarding the amount of fuel necessary for the operation of a small alcohol distillery. This dearth of accurate knowledge is regrettable, for the coal

bill is a prominent item in the distillery's expense account. Such data as are at hand indicate that the coal consumption—per gallon of 180-degree alcohol produced—may vary from 11 pounds under the most favorable conditions to 38 pounds in a poorly equipped and poorly managed plant. As 11 pounds of coal as a distillery fuel yield almost 159,000 heat units and a gallon of alcohol gives about 75,000, it is apparent that the use of alcohol so produced for heating would involve a great waste and be altogether unprofitable. Furthermore, the coal consumption of a small distillery will be proportionally greater than that of a large one, since many economies which are possible in a large plant are quite impracticable in a small one.

Conclusions

It is apparent that the business of distilling alcohol is one which calls for a considerable investment and no small degree of technical skill. It can not be conducted advantageously, from a commercial point of view, in very small plants on account of the proportionately high cost of the plant and labor; and many of the so-called "wastes" which have been suggested as fermentable raw materials are so poor in fermentable substance or so expensive to handle that their availability is thereby impaired. It seems that the business, to be productive of satisfactory returns, must be conducted on a fairly large scale, and that the best success is likely to be attained with raw materials of the general types already in use, namely, maize, potatoes, and molasses. The industry is not suited to every locality, and it is most likely to be successful if carried on systematically on a very large farm, or if supported by the joint interests of a fairly large community. The alluring statements sometimes made regarding large financial returns to be obtained by making industrial alcohol with waste raw materials, unskilled labor, and a "cheap" distilling outfit are misleading and can only result in loss if followed.

H. W. Wiley, Chief, Bureau of Chemistry, Revised by H. E. Sawyer, Fermentation Chemist, U. S. Department of Agriculture.

INDUSTRIAL ALCOHOL—ITS USES

Heating and Illumination

The most important of the uses of industrial alcohol as far as the farmer is directly concerned are those included in heating and illumination. For these purposes the farmers of the country, when the processes are adjusted and the technical difficulties of production, manufacturing, and denaturing are overcome, will find alcohol extremely useful. Especially will this be true in localities remote from centers of the production of wood, coal, kerosene, gasoline, natural gas, and oil, which now are the chief heating and illuminating agents.

Alcohol Stoves

The success of the alcohol stove depends largely upon the character of the wick, which must absorb the alcohol and be so adjusted as to give the necessary heating surface. By converting the alcohol into a gas and burning the vapor thus formed the wick may be dispensed with and a more effective burner obtained. The general principles involved in heating with alcohol are the same as for other heating substances. The only differences are in the methods of producing the combustion. Alcohol burns with a pale blue flame which is intensely hot. It is without smoke, and if there be any odor at all it is an agreeable and not a disagreeable one. The products of combustion of pure alcohol are water and carbon dioxide. The latter gas should be conducted out of the room by the ordinary methods of ventilation. No form of burner should be allowed to pour the products of combustion into the room. The water which is formed is harmless, but the carbon dioxide, which is produced in large proportions, will soon vitiate the air of the room and tend to produce drowsiness, headache, and injury to health. The common methods of burning gas and kerosene in a room without ventilation are also objectionable for the same reason. Some form of ventilation by means of

which the products could be removed from the room through a chimney or otherwise is highly desirable.

Stoves of many different kinds have been invented for burning alcohol. There are stoves for heating flatirons, soldering irons, crimping irons, roasting coffee, etc.

Alcohol Lamps

Alcohol can not be used directly for illuminating purposes. The flame does not possess any notable illuminating power. In order that alcohol may be used for illumination it must be burned in a state of gas and the heat produced by the combustion utilized to produce incandescence in the ordinary mantle which surrounds the common gas flame for the same purpose. It has been discovered that when certain earths, such as thoria, in a state of fine subdivision, are subjected to the action of a high temperature, they become intensely white and produce by their incandescence the maximum degree of illumination. The thoria is first deposited upon some substance such as cloth and so distributed that when the cloth burns away the particles of thoria remain in the original shape of the mantle. When held over the flame of gas or alcohol the particles become incandescent. To adjust an alcohol lamp for this purpose it is only necessary to make an attachment whereby the alcohol is first converted into a vapor. In order to light such a lamp a portion of the alcohol must first be vaporized.

It is evident that the amount of heat produced is to some extent a measure of the illuminating value when the incandescent mantle is taken into consideration. It is the high temperature which produces the incandescence and therefore the gas which in burning gives the highest temperature, other conditions being the same, would be of the most value for illumination. All of these points must be considered to prevent the formation of wrong opinions concerning the efficiency of alcohol for illumination, heating, and motive power, as compared with gasoline, which is the agent most used for these purposes, and which alcohol is expected to supersede.

Quantity of Heat Yielded in the Combustion of Alcohol

It has been estimated that 1 gram (*a*) of gasolene will yield on complete combustion 11,000 calories, (*b*) and 1 gram of pure alcohol 7,200 calories. No determination of the heat of combustion of ordinary commercial gasolene of the grade commonly used for fuel is found. Products of that nature appear to yield from 9,700 to 11,000 calories. In so far as heating purposes are concerned, therefore, it is evident that gasolene, weight for weight, is more valuable than alcohol.

Alcohol Motors

It is quite certain that the use of alcohol motors on the farm will become quite common as soon as the technique of construction is practically complete and the price of alcohol is sufficiently low. Alcohol can be used for all purposes for which gasolene is employed, namely, the driving of wagons, carriages, stationary motors, water pumps, mowing machines, plows, etc. Very little change need be made in the engine of a motor car designed to use gasoline to fit it for the use of alcohol. Gasolene becomes volatile at a temperature of blood heat (98.5 degrees Fahrenheit), while a much greater degree of heat (158 degrees to 176 degrees Fahrenheit) is necessary to volatilize alcohol rapidly enough for motor purposes. This fact makes necessary a change in the explosion chamber of the engine when alcohol is to be used. This adjustment is especially important in the starting of the machine, as after it is in action the temperature of combustion is quite sufficient to easily produce the gasification necessary.

In regard to heavy machines it may be said that they probably would come into use only on large farms where the surface of the soil is practically level. They would not be suitable for small farms nor those in hilly sections. In this connection attention is called to the fact that steam plowing, although practicable

and profitable under certain conditions, has not been practised to any great extent in this country, in fact, not nearly so much as in England. It is not likely, therefore, that plowing and harvesting by alcohol motors will come into use very soon, although the possibilities are worthy of the consideration of the thoughtful farmer. On the other hand, it seems probable that small motors for driving machines for chopping and grinding cattle food, pumping water, and similar purposes may be brought into very general use as soon as the denatured alcohol becomes cheap enough to render its use practicable.

In the driving of motor engines the quantity of heat evolved is not always a measure of efficiency. It is not the purpose of this article to go into this subject at all, only to say that the vapor of alcohol can be more highly compressed at any given temperature without exploding than can the vapor of gasolene. As the decreased volume of the mixture of the explosive vapor and air is to a certain extent a measure of efficiency when engines are driven by the expansion of gases, the high degree of compressibility of the alcohol vapor without danger of explosion may compensate for the smaller quantity of heat which is generated by its combustion.

The problems connected with the use of alcohol for driving machinery are somewhat technical, and it is only desired to call attention to the possible advantages to the farmer from this source of power, and also to point out the difficulties which must be overcome. In this connection it seems that a word of caution is needed, as in the exploitation of tax-free alcohol extravagant opinions regarding its possibilities have been expressed. These exaggerated statements have been made without any intent to deceive or mislead, but on account of insufficient information. The natural tendency in all such matters is to select those points which are certain to be of great benefit and publish them broadcast, and to neglect the difficulties and dangers which lie in the path of progress along

a 1 gram = 0.03527 ounce, or 15 grains.

b A calorie is the amount of heat necessary to raise 1 gram of water 1° centigrade (1.8° Fahrenheit).

these lines. Farmers, who are naturally conservative, need very little caution in such matters, but it is important that a full understanding of the difficulties of these problems should be disseminated.

It is quite certain that if alcohol can be produced in the near future at a cost not exceeding 25 or 30 cents per gallon of 95 per cent strength, it will be a most valuable source of power on the farm. Although with the present relative prices of alcohol and gasoline there is no financial advantage in the use of the former, it is highly probable that the price of gasoline will advance and that of alcohol fall. Thus the farmhouse and the barn may be liberally supplied with water at such an elevation that it can be used with all the facility enjoyed by those who live in the city by means of a safe, cheap, and effective method of pumping made possible by the alcohol motor. The machinery around the barn and the stables which is utilized for chopping food and grinding grain in the preparation of rations for domesticated animals should be of a character which is efficient and at the same time without danger. An alcohol motor placed in a small room separated from the barn at such a distance as not to endanger it in case of an accident would make it possible to supply power of this kind. Although alcohol is far less dangerous in use than gasoline as far as probability of explosion is concerned, there should be no misunderstanding respecting the fact that it is an explosive substance both when in the form of vapor and when mixed with air, and all the precautions which are used in the case of gasoline should be employed also with alcohol. While the use of these precautions will practically eliminate any source of danger, it is nevertheless advisable, even in the case of alcohol, to separate the building in which it is used from the barn, which contains more or less highly combustible matter. The fact that a substance is less dangerous than another is no excuse for omitting any of the precautions to prevent injury as the result of accident.

Uses Not Directly for Farm Operations

It seems advisable that some of the uses of industrial alcohol not directly connected with farm operations should be known to the farmer, in order that he may be fully informed respecting the industry in which he necessarily takes so important a part. The purposes for which tax-free alcohol can be used in the arts are fully set forth in a public document entitled "Free Alcohol, Hearings before the Committee on Ways and Means, House of Representatives, Fifty-ninth Congress, First Session, February-March, 1906." A very full discussion of the subject is also found in an English report entitled "Industrial Alcohol Committee, Minutes of Evidence Taken Before the Departmental Committee on Industrial Alcohol, with Appendices. Presented to Both Houses of Parliament by Command of His Majesty. Printed for His Majesty's Stationery Office by Wyman & Sons (Limited), Fetter Lane, London, E. C., 1905." The evidence submitted in the two reports mentioned contains practically all that is known concerning the uses of denatured alcohol. It is not intended here even to make a resume of this evidence; only the most important uses which are benefited by tax-free alcohol can be mentioned.

Varnishes, Lacquers, Etc.

One of the most important technical uses of alcohol is in the manufacture of varnishes and lacquers, where the gums which are employed are necessarily dissolved in alcohol. This use of alcohol is extremely important and affects a great many industries.

Ether

The ether of commerce, sometimes called sulfuric ether, is manufactured exclusively from alcohol by the action of sulfuric acid and heat. This ether is used in a great many technical operations, since it is one of the best solvents known, especially for fats. It is also extensively used in surgery as an anesthetic. Under the present arrangements ether used for technical purposes can only be made from alcohol on which tax has been paid, and

thus its price is phenomenally high. By the use of tax-free alcohol for making ether, this price would be proportionally reduced, and in some countries the law permits the use of alcohol denatured by a special formula for this purpose. The denaturation of alcohol by the general process prescribed by the Commissioner of Internal Revenue (*a*) may unfit it for the manufacture of ether, even if such use were deemed admissible under the new law (*b*) and the regulations made in conformity therewith.

Imitation Silk

The substance which is known as imitation silk is really a production from cotton or other cellulose material which, in its finished state, resembles silk somewhat in luster. It is not silk, and hence not even artificial silk. It is a textile product which has the promise of a successful future and is therefore of interest not only to the manufacturer and the consumer but to the farmer who produces the cellulose. Imitation silk is in a measure the same substance as smokeless powder, except that after it is made the nitrogenous constituents are removed, so as to restore the finished product again to the condition of ordinary cotton, devoid of explosive properties. In the making of imitation silk a partial nitrification of the cotton is accomplished in much the same manner as in making smokeless powder. The partially nitrated cotton is then reduced to a paste by solution in alcohol, ether, or other solvent, and in this condition is forced through small orifices, producing fine fibers of a silky luster. After these are produced the oxid of nitrogen is removed from them by a chemical process which does not interfere with their lustrous appearance. These fibers are then spun and woven as ordi-

a The formula for completely denaturing alcohol given by the regulations of the United States Internal Revenue is as follows. To 100 parts of ethyl alcohol add 10 parts of approved methyl alcohol and one-half of 1 part of approved benzin. Formulas for special denaturants for specific purposes are to be submitted by manufacturers to the Commissioner of Internal Revenue, who will announce from time to time what formulas may be used in the several classes of industries.

b For the text of the law permitting the use of denatured alcohol, tax-free, for industrial purposes, see p. 28.

nary silk or cotton, producing fabrics which resemble in luster the natural silk. The utilization of tax-free alcohol would be a great stimulus to the advancement of industries of this class.

Artificial Vinegar

Dilute alcohol, commonly known as low wines, can be utilized for the manufacture of vinegar. For this purpose the dilute alcohol is made to pass over the fresh shavings of beech wood. These beech shavings furnish the organisms which oxidize the alcohol into acetic acid, and after passing through a series of vats containing these shavings the alcohol is converted into a dilute solution of acetic acid. During the process there is a considerable loss of alcohol by evaporation. It is estimated that only about 70 per cent of alcohol is finally recovered as vinegar. This material ought not to be called vinegar, as it is acetic acid pure and simple. It is colored and treated so as to resemble vinegar made from cider or wine or malt, and to this extent becomes an adulteration. This industry may be mentioned as one that would be promoted by the use of tax-free alcohol, although it deserves little if any encouragement. Section 59 of the Regulations concerning denatured alcohol, however, especially names "manufacturers of vinegar by the vaporizing process" among the classes of persons who may not store denatured alcohol on their premises or make use of it.

Flavoring Extracts

The flavoring extracts of commerce are made largely with alcohol as a solvent. This should be the purest possible alcohol, and since it can not possibly be denatured and still remain potable and attractive, the law would probably not apply under conditions of this kind.

Use of Undenatured Alcohol Free of Tax

Under laws other than the denatured alcohol law, alcohol may be withdrawn from the distillery warehouse free of tax for certain purposes. Among these may be mentioned its use by the United States Government, its use for scientific purposes under certain conditions, and its

use in the manufacture of sugar from sorghum. During the year ended June 30, 1905, 2,112,830.9 gallons of spirits were withdrawn for these purposes. Details in regard to such withdrawals can be obtained from the Commissioner of Internal Revenue, whose annual report for the year ended on the date mentioned furnishes valuable information for those proposing to engage in any way in the distillation of alcohol.

Attention should also be called to the fact that large quantities of undenatured alcohol are manufactured in the United States on which no tax is paid. The principal sources of this alcohol are as follows:

Hard Cider

The natural conversion of sweet cider into hard cider by the ferments which it contains is a process in which large quantities of alcohol are produced and on which no tax is paid. The term alcohol when used alone does not apply to such products, but only to alcohol produced by distillation. As is well known, the sugar which is one of the principal constituents of fresh cider is mixed with yeasts which naturally attach to apples, so that when exposed without sterilization fermentation takes place, the sugar disappears, and alcohol is formed. If we assume that the average apple juice contains 12 per cent of fermentable matter, it is seen that about six per cent of alcohol may be developed in a hard cider. No tax is put upon this cider, nor is there any supervision on the part of the Commissioner of Internal Revenue in its production.

Wine

In the manufacture of wine the natural yeasts which attach to the grapes produce in the expressed grape juice a fermentation by means of which the grape juice is converted into wine. This is a vast industry in many countries and a very important industry in the United States. The alcohol which is formed in this way pays no tax, nor does the manufacturer of ordinary wines conduct his business under the supervision of the Commissioner of Internal Revenue. What

is true of the juices of the grape and the apple is true of other fruit juices. They may be all of them fermented and their sugar converted into alcohol without Government supervision and without paying any tax. But when the alcohol which is produced by the fermentation of fruit juices is subjected to distillation it comes under the control of the Commissioner of Internal Revenue. The distillation of alcohol from waste products is conducted under special regulations authorized by law.

Sweet Wine

Brandy and other distilled spirits made from grapes or their refuse may be used for fortifying sweet wines upon the payment of a nominal tax of 3 cents a gallon, as provided for by the following act of Congress, which indicates the character of the wines that may be fortified in this way:

AN ACT To amend existing laws relating to the fortification of pure sweet wines.

Be it enacted by the Senate and House of Representatives of the United States of America in Congress assembled, That section forty-three of the Act entitled "An Act to reduce the revenue and equalize duties on imports, and for other purposes," approved October first, eighteen hundred and ninety, as amended by section sixty-eight of the Act of August twenty-seventh, eighteen hundred and ninety-four, be further amended, so as to read as follows:

SEC. 43. That the wine spirits mentioned in section forty-two of this Act is the product resulting from the distillation of fermented grape juice, to which water may have been added prior to, during, or after fermentation, for the sole purpose of facilitating the fermentation and economical distillation thereof, and shall be held to include the product from grapes or their residues, commonly known as grape brandy; and the pure sweet wine, which may be fortified free of tax, as provided in said section, is fermented grape juice only, and shall contain no other substance whatever introduced before, at the time of, or after fermentation, except as herein expressly provided; and such sweet wine shall contain not less than four per centum of saccharine matter, which saccharine strength may be determined by testing with Balling's saccharometer or must scale, such sweet wine, after the evaporation of the spirits contained therein, and

restoring the sample tested to original volume by addition of water, *Provided*, That the addition of pure boiled or condensed grape must or pure crystallized cane or beet sugar or pure anhydrous sugar to the pure grape juice aforesaid, or the fermented product of such grape juice prior to the fortification provided by this Act for the sole purpose of perfecting sweet wines according to commercial standard, or the addition of water in such quantities only as may be necessary in the mechanical operation of grape conveyors, crushers, and pipes leading to fermenting tanks, shall not be excluded by the definition of pure sweet wine aforesaid: *Provided, however*, That the cane or beet sugar, or pure anhydrous sugar, or water, so used shall not in either case be in excess of ten per centum of the weight of the wine to be fortified under this Act: *And provided further*, That the addition of water herein authorized shall be under such regulations and limitations as the Commissioner of Internal Revenue, with the approval of the Secretary of the Treasury, may from time to time prescribe; but in no case shall such wines to which water has been added be eligible for fortification under the provisions of this Act where the same, after fermentation and before fortification, have an alcoholic strength of less than five per centum of their volume

SEC. 2. That section forty-nine of said Act, approved October first, eighteen hundred and ninety, be amended so as to read as follows:

SEC. 49. That wine spirits used in fortifying wines may be recovered from such wine only on the premises of a duly authorized grape-brandy distiller; and for the purpose of such recovery wine so fortified may be received as material on the premises of such a distiller, on a special permit of the collector of internal revenue in whose district the distillery is located; and the distiller will be held to pay the tax on a product from such wines as will include both the alcoholic strength therein produced by the fermentation of the grape juice and that obtained from the added distilled spirits, subject, however, to the provisions of section thirty-three hundred and nine of the Revised Statutes of the United States, as amended by section six of the Act entitled "An Act to amend the laws relating to internal revenue," approved March first, eighteen hundred and seventy-nine; and such spirits so recovered may be used by such distiller to fortify wines as authorized by section forty-two of the aforesaid Act, approved October first, eighteen hundred and ninety.

SEC. 3. That the Commissioner of In-

ternal Revenue is hereby authorized to assign at each winery where wines are to be fortified such number of gaugers or storekeeper gaugers, in the capacity of gaugers, for special duties as may be necessary for the proper supervision of the making and fortifying of such wines, and the compensation of such officers shall not exceed five dollars per diem while so assigned, together with their actual and necessary traveling expenses, and also a reasonable allowance for their board bills, to be fixed by the Commissioner of Internal Revenue, but not to exceed two dollars per day for said board bills; and to cover the expenses to the Government attending the making and fortification of such sweet wines there shall be levied and assessed against each maker of such wines, and collected monthly, a charge of three cents on each taxable gallon of brandy used by him in the fortification of such wines during the preceding month. That bonds hereafter given under the provisions of the aforesaid Act of October first, eighteen hundred and ninety, as amended, shall be conditioned for the payment of the tax on all brandy removed thereunder and not used and accounted for within the time and in the manner required by law and regulations, and for the payment of all charges herein imposed on the brandy so withdrawn and used; and the said bond shall contain such other conditions as the Commissioner of Internal Revenue, with the approval of the Secretary of the Treasury may by regulation prescribe.

SEC. 4. That where brandy to be used in the fortification of wine is distilled on premises adjacent to the winery premises the Commissioner of Internal Revenue may, in his discretion, authorize the erection on either of said premises of fermenting vats for material to be used either in the manufacture of such wines or the brandy to be used in the fortification thereof; and all such materials used or received on either of said premises shall be under the supervision of the officer assigned to such winery, and shall be accounted for at such times and in such manner as the Commissioner may direct.

SEC. 5. That the provisions of sections thirty-two hundred and twenty-one and thirty-two hundred and twenty-three of the Revised Statutes of the United States, as amended by an Act approved March first, eighteen hundred and seventy-nine, are hereby extended to grape brandy withdrawn for use in the fortification of sweet wines, and which, prior to such use, is accidentally destroyed by fire or other casualty while stored in the fortifying room on the winery premises.

SEC. 6. That any person who by any process recovers from wines fortified under the provisions of the aforesaid Act approved October first, eighteen hundred and ninety, or amendments thereto, any brandy or wine spirits used in the manufacture or fortification of said wine, otherwise than is provided for in said Act and its amendments, or who shall rectify, mix, or compound with other distilled spirits such fortified wines or grape brandy or wine spirits unlawfully recovered therefrom, shall, on conviction, be punished for each such offense by a fine of not less than two hundred dollars nor more than one thousand dollars. But the provisions of this section, and the provisions of section thirty-two hundred and forty-four of the Revised Statutes of the United States, as amended, relating to rectification, shall not be held to apply to the blending of pure sweet wines fortified under the provisions of the said Act of October first, eighteen hundred and ninety, or amendments thereto, where such wines are blended for the sole purpose of perfecting the same according to commercial standard.

H. W. WILEY,

Chief, Bureau of Chemistry, U. S. Department of Agriculture.

ALCOHOL AND GASOLINE IN FARM ENGINES

Sources of Power

There are two great sources of power and an infinitely varied series of mechanical devices and machines for the generation of power. Water power always has been used and probably always will be used so long as the rain falls, but it is insufficient for our present needs or geographically unavailable. The greatest source of power is fuel. Fuels may be divided into two series—those that now exist in the form of natural deposits and those which are being produced continuously. All of the coals, hard and soft, with the lignites and peats, the crude oils and natural gas, exist in the form of deposits; and, while it is true that the decay of vegetable matter may be today forming more deposits of the same nature, it is equally true that we are using the present supply faster than the rate of production. The newest fuel for power purposes is alcohol. This is made from the yearly crops of plants. There is in existence no natural deposit of alcohol, but in a sense it may be said to be possible to produce inexhaustible supplies.

It is only within recent time that engineers have known how to build engines that would produce power from alcohol; and still more recent is the further discovery by engineers that this power can be produced at a cost which may permit its general introduction.

By far the largest part of the power now being used comes from steam produced by the use of coal. This is chiefly due to the fact that as a rule when it can be used it is cheaper than possible substitutes, although it is partly due to the fact that steam power is better adapted to some classes of work and is older and better known than power generated by the gas engine in its varied forms. In the point of present use, water power stands next to steam in importance. This is largely due to the fact that water power is among the earliest in point of development, but more largely to the fact that it has become possible to transform water power into electrical power, which can be transmitted long distances, and so overcome geographical isolation of the sources.

Next in quantity produced stands power generated by the gas engine. This class of engines includes all machines in which the fuel mixed with air is burned or exploded within the working chambers, whether the fuel be gas produced from coal, natural gas, vapors of any of the mineral oils, vegetable or animal oils, or alcohol. The subordinate position occupied by this source of power is due partly to the fact that engineers have only recently discovered, and are today discovering, how best to build these machines and adapt them to the work they are to do. Wind and wave power stand at the foot of the list and always will, so far as quantity of power developed is concerned. This is because of the irregularity of the sources of supply and their comparatively feeble nature.

Comparative Cost of Power from Different Sources

The cost of producing power from any of the above sources is made up of a number of items, including interest on the first cost of the installation, depreciation

of the apparatus, its insurance, etc., usually called the "fixed charges." To these should be added the costs of fuel, of labor for attendance, and of repairs, as the principal items, and the cost of lubricants, material for cleaning, and a great many other small miscellaneous items, all going to form what are commonly called "operating charges." In all cases where fuel is used its cost is, if not the most important, certainly a very important item. In the case of water power, where the fuel element is zero, the advantage is offset by an interest charge on the cost of installation for dams, pipes, tunnels, shafts, etc. Assuming that power from all of these different sources is equally well adapted to the particular work to be done and equally available, then that system will be selected for any particular case for which the cost of power is least. Leaving out of consideration water power, it is found that the labor costs do not differ nearly so widely for the different systems, nor are they so large, as the fuel cost. Therefore, the great question today in power production as regards immediate cost of power and maintenance is this lowering of the fuel cost.

The cost of fuel per unit of power developed depends, first, on the market price of that fuel at the point where it is to be used, and next, but by no means least, on the ability of the machinery to transform the fuel energy into useful work. If all the different kinds of machinery used for power generation could turn into useful work the same proportion of the energy in the fuel, coal would be almost universally used, because of the present low cost of energy in this form.

Comparative Cost of Energy in Different Fuels

The different kinds of fuel contain different amounts of energy per pound—that is to say, they have different heating powers. Heat energy is measured in terms of a technical unit called by English-speaking people the "British thermal unit" (B. T. U.). This unit is the amount of heat that will raise the temperature of one pound of water one degree on the Fahrenheit thermometer. In comparing,

therefore, the value of fuels for power purposes there must be taken into consideration two facts—the market price of the fuel and the amount of heat which will be liberated when it is burned. Anthracite coal in the neighborhood of New York can be bought in small sizes in large quantities for power purposes at about \$2.50 per ton. This coal will contain about 12,500 B. T. U. per pound. This is equivalent to about 10,000,000 heat units per dollar. Large sizes, such as egg coal, containing about 14,000 B. T. U. per pound, can be bought in large quantities for about \$6.25 per ton, which is equivalent to 4,500,000 B. T. U. per dollar. Other grades of anthracite coal and the various grades and qualities of bituminous coal will lie between these two limits of cost. Illuminating gas in New York costs \$1 per 1,000 cubic feet, which is equivalent to about 500,000 heat units per dollar. Natural gas in the Middle States is sold for 10 cents per 1,000 cubic feet and upward. This fuel at the minimum price will furnish about 10,000,000 heat units for a dollar. Crude oil sells in the East at a minimum price of 4 cents per gallon, which is equivalent to about 4,000,000 heat units per dollar. Gasoline sells at a minimum price of 10 cents per gallon, which is equivalent to about 1,200,000 heat units per dollar. Kerosene sells from 10 to 30 cents per gallon, which is equivalent to 1,200,000 and 400,000 heat units per dollar, respectively. Grain alcohol, such as will be freed from tax under the recent legislation, will sell for an unknown price; but for the purpose of comparison assuming 30 cents per gallon as a minimum, it will give 270,000 heat units per dollar. Gasoline, kerosene, crude oils, and, in fact, all of the distillates have about the same amount of heat per dollar, whereas at the same price per gallon, ignoring the slight difference in density, they would deliver to the consumer about the same amount of heat per dollar, whereas the other liquid fuel, alcohol, if sold at an equal price, would give the consumer only about three-fifths the amount of heat for the same money. From the figures above given it appears that the cost of heat energy contained in the above fuels, at the

fair market prices given, varies widely, lying between 200,000 heat units per dollar and 10,000,000 heat units per dollar. It is possible to buy eight times as much energy for a given amount of money in the form of cheap coal as in the form of low-priced gasoline, or 25 times as much as in the form of high-priced gasoline or kerosene. This being true, it might seem to a casual observer as rather strange that gasoline should be used at all, and the fact that it is used in competition with fuel of one-eighth to one twenty-fifth its cost shows clearly that either the gasoline engine has some characteristics not possessed by an engine or plant using coal, which makes it able to do things the other can not do, or that more of the heat it contains can be transformed into energy for useful work. Both of these things are true.

Thermal Efficiency

As was pointed out before, the different kinds of machinery used to generate power render more or less of the fuel energy into useful work; all systems do not give equal returns for equal amounts of heat supplied. If all the heat energy in fuel were transformed into work with no losses whatever in the mechanism, the machinery would be said to have a thermal efficiency of 100 per cent, and it would require 2,545 heat units per hour to maintain an output of one horsepower. If half of the energy in the fuel were lost in the machinery, its thermal efficiency would be said to be 50 per cent, and there would be required 5,090 heat units per hour. If only one per cent of the heat energy in the fuel were transformed into useful work, the efficiency of the machinery or power plant would be said to be one per cent and there would be required 254,500 heat units per hour to maintain one horsepower.

Steam plants in use represent a great variety of styles or types, but in general it may be said that the more complicated and refined the plant the larger its size the more efficient it is, because the complication exists only as evidence of an attempt to minimize the losses of heat in the machinery. Similarly the more stead-

ily the plant works at the output for which it was designed the higher the efficiency of the plant, and, conversely, the smaller the plant the simpler the apparatus, or the more intermittently it works, the lower its efficiency. Steam-power plants are built today to do every conceivable sort of work, and range in size from one horsepower to 100,000 horsepower. For purposes of comparison neither the largest nor the smallest should be used, nor the best performance nor the worst performance of these plants, but a figure representing a fair average for the conditions named should be taken. Large steam plants in their daily work seldom use less than two pounds of poor coal per hour for each useful horsepower (known as a brake horsepower), which is equivalent to about 25,000 B. T. U. per hour, and which corresponds to about 10 per cent thermal efficiency. Small steam plants working intermittently, such as hoisting engines, may use as high as seven pounds of coal per brake horsepower, which is equivalent to about 100,000 heat units per brake horsepower hour, or 2.5 per cent thermal efficiency. Some plants will do better than the above with proper conditions, and some may do worse, but in general it may be said that the performances of steam plants lie between the limits of 2.5 and 10 per cent thermal efficiency.

Plants consisting of gas producers for transforming coal into gas for use in gas engines have in general a much higher thermal efficiency than steam plants doing the same work. They are, however, not built quite so small as steam plants, the smallest being about 25 horsepower, and in general they have not been built so large, the largest being only a few thousand horsepower. Their efficiency, however, does not vary so much as is the case with steam plants. It may be fair to say that under the same conditions as above outlined these plants will use $1\frac{1}{4}$ to 2 pounds of coal of fair or poor quality per brake horsepower hour, which gives a thermal efficiency ranging from 18 to 10 per cent. These plants can be made to do much better than this, and perhaps may do worse, although the variation is not nearly so great as for steam plants.

Gas engines operating on natural gas or on illuminating gas from city mains will, on fluctuation of load with the regular work, average about 12,000 heat units per brake horsepower hour, or 20 per cent thermal efficiency. Exploding engines operating on crude oil will average about 25,000 heat units per brake horsepower hour, which is equivalent to about 10 per cent thermal efficiency. Exploding engines using gasoline should operate at a thermal efficiency of about 19 per cent under similar operating conditions.

The efficiency of an alcohol engine may be assumed at this time to be unknown, but as alcohol can be burned in engines designed for gasoline, it may be assumed that such an engine will have with alcohol fuel the same thermal efficiency as with gasoline, to-wit, 19 per cent for fair working conditions.

From the above brief discussion of the efficiency of different methods of power generation from different fuels it appears that quite a range is possible, though not

so great a range as exists in the case of cost of fuel energy. Efficiency is seen to lie somewhere between 2½ and 20 per cent for all the fuels under working conditions. It is known that actual thermal efficiency under bad conditions may be less than one per cent and under the best conditions as high as 40 per cent, but these are rare and unusual cases. The range given is sufficient to indicate that a highly efficient method may make the fuel cost per unit of power less with quite expensive fuel than it would be with cheaper fuel used in a less efficient machine. It is also perfectly clear that without proper information on the efficiency of the machine or the efficiency of the plant it is impossible to tell what the cost of fuel per horsepower hour will be, even though the price of the fuel per ton or per gallon be known. From the figures given on the cost of fuel and a fair average for plant efficiency the cost of fuel per horsepower hour is computed as given in the following tables:

Cost of Energy in Fuels

Kind of Fuel	Cost of Fuel	British thermal units (B. T. U.)	Number of B. T. U. bought for \$1
Small anthracite.....	\$2.50 per ton....	12,500 per pound..	10,000,000
Large anthracite....	6.25 per ton.....	14,000 per pound..	4,500,000
Illuminating gas..	1.00 per 1,000 cubic feet.	550 per cubic foot....	550,000
Natural gas....	.10 per 1,000 cubic feet.	1,000 per cubic foot...	10,000,000
Crude oil.....	.04 per gallon.....	20,000 per pound....	3,650,000
Kerosene.....	.10 per gallon.....	20,000 per pound....	1,200,000
do.....	.30 per gallon.....	20,000 per pound....	400,000
Gasoline.....	.10 per gallon.....	20,000 per pound....	1,200,000
do.....	.30 per gallon.....	20,000 per pound....	400,000
Grain alcohol....	.30 per gallon.....	12,000 per pound....	270,000
do.....	.40 per gallon.....	12,000 per pound....	200,000

Fuel Cost of Power

Fuel and type of plant	Fuel required per horsepower per hour	British thermal units required per horsepower hour	Thermal efficiency	Cost of fuel	Cost of fuel per horsepower per hour
Anthracite coal:			Per cent		Cents
Large steam plant....	2 pounds.....	25,000	10	\$2.50 per ton.....	0.25
do.....	2 pounds.....	25,000	10	6.25 per ton.....	.57
Small steam plant....	7 pounds.....	100,000	2½	2.50 per ton.....	1.00
do.....	7 pounds.....	100,000	2½	6.25 per ton.....	2.20
Producer gas plant....	1¼ pounds....	14,000	18	2.50 per ton.....	.14
do.....	1¼ pounds....	14,000	18	6.25 per ton.....	.31
do.....	2 pounds.....	25,000	10	2.50 per ton.....	.25
do.....	2 pounds.....	25,000	10	6.25 per ton.....	.57
Illuminating gas.....	24 cubic feet..	12,000	20	1.00 per 1,000 cubic feet.	2.20
Crude oil.....	1.4 pints.....	25,000	10	.04 per gallon.....	.68
Gasoline.....	1.1 pints.....	13,400	19	15 per gallon.....	1.70
do.....	1.1 pints.....	13,400	19	.30 per gallon.....	3.40
Alcohol.....	a19	.30 per gallon.....	5.00
do.....	a19	.40 per gallon.....	6.70

a Efficiency of alcohol is assumed to be the same as that of gasoline for identical conditions of use.

Adaptability of Various Types of Engines

The foregoing table shows very clearly that the cost for fuel to maintain a brake horsepower for one hour varies widely, and at the prices given the dearest costs nearly 48 times as much as the cheapest. The fact that not everybody uses the fuel giving the cheapest power in point of fuel cost, but that even the most expensive finds a ready market, makes it clear that there must be good reasons. These reasons may be found in local variations in price of fuel, in differences in adaptability of the engines to the work required, and in the fact that the above figures show fuel cost only, whereas there are great differences in the cost of attendance. An elaborate steam plant, to be even fairly efficient, must be continuously operated at fairly heavy load; intermittent working or working at a decreased output makes them wasteful of fuel. Moreover, the apparatus is so complicated, slow to start up, and dangerous to life and property in careless or inexperienced hands that persons must become skilled by years of study and practice before they may be allowed the handling.

The gas engine with its producer can handle today the same kind of coal that is used in steam plants, and yet the weight of this apparatus and its lack of flexibility compared with steam engines, make it unavailable for steamships and locomotives; so it is clear again that adaptability to service is even more important than the cost of fuel. Similarly, gas-producer plants have not yet been successful for sizes smaller than 25 horsepower, and especially unsuccessful have they been so far for intermittent work. For the small sizes the steam plant is also very wasteful of fuel, requires a skilled operator, and is slow in starting; so it is clear why engines burning crude oil, gasoline, kerosene, and other liquid fuels explosively should be used for light work in isolated situations where the work is intermittent and where quick starting and small care in attendance are essential. In this connection it must not be forgotten that a kerosene, gasoline, or crude-oil engine can be start-

ed in a few minutes and can even be left running for practically a whole day with only an occasional examination to see that the oil cups are flowing properly and the bearings are not getting hot through being dirty. Steam engines with their boilers, on the contrary, can not be started inside of one or two hours, and all the fuel necessary to raise steam is wasted so far as the work to be done is concerned. Moreover, a steam engine requires continuous feeding of coal and close attention, so that a man must be always near it having no other duties but its care.

In the natural-gas regions a large number of gas engines are working and in the oil regions a similar number of oil engines and gasoline engines, because the nearness to the supply makes the fuel cheaper than transported fuel, and the exploding engine is more efficient than the steam engine.

It thus appears that in spite of the fact that the fuel element in the cost of power is high for engines burning crude oil, kerosene, and gasoline in comparison with those using coal, at the same time they possess advantages that do not exist in steam plants and gas-producer plants, which give them a very distinct field, as indicated by the following uses to which these engines are being put today: Driving boats, automobiles, and railroad motor cars; pumping water for private houses, for farms, for irrigation, and in some cases for municipal service in small towns; compressing air for drilling, hoisting, riveting, etc.; operating small carpenter shops, machine shops, forge shops, and, in fact, any kind of small shop; operating ventilating fans in buildings and in mines; running small factories, such as creameries and butter factories; operating feed-cutting and grinding machinery, corn shredders, and thrashing machines; operating other special machines, such as ice-cream freezers, printing presses, mostly small in size, and making electric light in isolated localities. Not only is this field a real one, but it is a large one, as is shown by the number of these small engines being sold today. The exact figures on the sales are

not available and it is impossible to secure them because of the unwillingness of manufacturers to tell their business, but when a single manufacturer (as is the case) is selling 425 per day, and there are in the United States alone some 300 manufacturers of importance, there can be no doubt as to the popularity of these machines.

Alcohol at a price unknown now becomes available for use in engines, whose peculiarities are not fully known and whose ability to transform heat into work is correspondingly in question. If the alcohol engine can be shown to have an efficiency as high or higher than other liquid-fuel engines and be similar in type and characteristics, it can do all that they can do, and its field will be the same as their field in spite of fuel costs; but by field is meant the nature of the work rather than the geographical location. It is likely that the alcohol engine will find as favorable a geographical location as the natural-gas engine and the oil engine have near the source of supply and far from the source of competing supply. But should it appear that the alcohol engine can do more or better work than its oil or gasoline competitors, its field will be wider. In any case the position which the alcohol engine may take today is no criterion as to its future, because it will operate on a source of energy or fuel supply which, as pointed out, is inexhaustible, whereas the supply of both crude oil and its distillates may ultimately become exhausted.

The determination, then, of the position of the alcohol engine today involves a forecast of the future, and should it be shown to be able to compete now it must inevitably reach a stronger and more important industrial position as time goes on. This is the fact that has led governments to take up the question, and among them the United States is the latest.

First Use of Alcohol Engines

About the year 1876 there was placed on the American market the first successful internal-combustion engine using petroleum distillate. This engine was invented by George Brayton. Following the at-

tempt of Brayton to use petroleum distillate came a series of inventions improving this class of engine, lasting for about twenty years, when the modern forms of kerosene, gasoline, and crude-oil engines may be said to have been developed. During this time the subject of alcohol as fuel in engines seems to have been either not thought of at all or not given any attention. The first serious attempt to examine into the possibility of alcohol as a fuel in competition with petroleum and its distillates seems to have been made in the year 1894 in Leipzig, Germany, by Professor Hartman for the Deutschen Landwirtschafts-Gesellschaft. The engine used was built by Grobb, of Leipzig, to operate on kerosene, and used 425 grams of kerosene per hour per brake horsepower, which is equivalent to 0.935 pound, or 1.1 pints, approximately. This indicates for the kerosene a thermal efficiency of 13.6 per cent. When operating on alcohol the engine used about twice as much, or 839 grams, which with this kind of alcohol was equivalent to a thermal efficiency of 12.2 per cent or a little less than with kerosene. This experiment would seem to indicate that, compared with kerosene, alcohol, as a fuel, offered very little chance for successful competition. In spite of this, however, very vigorous efforts were made to develop an alcohol engine that would be better than this one, and thus was inaugurated a remarkable series of experiments, congresses and exhibitions with the one end in view—of stimulating the production of the best possible alcohol motor.

The first stimulus was given by the German alcohol distillers, who sought to enlarge their market. They succeeded in interesting the German government in the question by enlarging on the national significance of having available a source of fuel for power, inexhaustible in quantity, to be produced within the national domain from the yearly crops. Under the double stimulus of government assistance and the desire of the distillers to increase their output, inventors and manufacturers were induced to spend their time and money with a resulting decided improve-

ment in the motor. An engine built by Korting Brothers of Hanover, fitted with a vaporizer invented by Petreano, tested at the Polytechnic School at Charlottenburg by Professor Slaby showed a consumption of 550 grams of 86.2 per cent alcohol by weight, which is equivalent to 1.21 pounds, or 1.4 pints, or a thermal efficiency of 17.5 per cent. This result showed an advance of nearly 50 per cent in thermal efficiency over the Grobb engine tested a year or so earlier by Professor Hartmann. Following this improvement there resulted a continual development of the alcohol motor, interest in which was kept up by exhibitions in which prizes were offered and by scientific societies. The most important of these are given below:

Exhibition at Halle-on-Saal, Germany, June 13-18, 1901.

Exhibition (national) at Paris, France, November 16-24, 1901.

Exhibition at Berlin, Germany, February 8-16, 1902.

Exhibition (international) at Paris, France, May 24-June 1, 1902.

Exhibition at Madrid, Spain, late in the year 1902.

Congress at Montpellier, October 11-21, 1902.

Congress at Paris, France, March 11-17, 1902.

Exhibition (international) at Vienna, Austria, April 2-June 12, 1904.

Exhibition at Rome, Italy, February 6-16, 1904.

Besides the above named, there were many others of lesser importance, all contributing to the rapid development of this class of machine.

The results of this development may be summed up by saying that the thermal efficiency of the motor was raised to something over 30 per cent, which is quite a remarkable showing in comparison with the original figure of 12.2 per cent in 1894. It must be clearly understood, however, in interpreting these figures that they are the best possible attainable at the time reported. They indicate, so far as the fuel costs are concerned, that with a motor specially constructed for alcohol the fuel prices per gallon might be twice as much for alcohol as for petroleum distillate and still give power for less money, assuming that at-

tendance, repairs, lubrication, etc., cost no more in the case of the alcohol engine.

The Office of Experiment Stations of this Department, in connection with its Irrigation and Drainage Investigations, has tested a number of different types of gasoline engines with alcohol, and obtained figures which show the comparative consumption of gasoline and alcohol in the same engine. The detailed results of these tests will be published in a technical bulletin, but the general results may be given here. The first tests were made without any particular attempt at obtaining the best adjustment of the engine for each fuel, and showed a consumption of alcohol two to three times as great by weight per horsepower hour as was necessary with gasoline or kerosene. These figures indicate the necessity or desirability of determining the proper conditions of adjustment, because these were found to have a serious influence on the amount of fuel consumed. With care in adjusting the engine so as to secure the most economical use of the alcohol, it was found that, under like conditions, a small engine consumed 1.23 pounds of alcohol to 0.69 pounds of gasoline per brake horsepower hour—that is to say, with the best adjustment of the engine for each fuel there was required 1.8 times as much alcohol by weight as gasoline per brake horsepower hour. It was also shown in making this adjustment that it was possible to burn more than twice as much alcohol as stated, by improper adjustments, and still have the engine working in an apparently satisfactory way. The range of excess gasoline which might be burned without interfering seriously with the working of the engine was not so great, being a little less than twice as much as the minimum. These early experiments, therefore, confirmed the early results secured in Germany, to-wit, that an engine built for gasoline or kerosene will, when unchanged, require about twice as much alcohol by weight for the same work; but they also indicate something that is not pointed out by the reports sent us from abroad—that is, the great importance of securing the best adjustment of the machine.

To understand why this adjustment of the machine can have such a serious effect and at the same time understand why exploitation and study were successful abroad in raising the efficiency of the alcohol engine from 12.2 to over 30 per cent in five or six years requires a knowledge of technology. The reasons can only become clear to one understanding the mechanism of these engines and to one familiar with the chemistry of the fuels and the physical theories of explosive combustion.

CHARLES EDWARD LUCKE,

M.S., Ph.D., Assistant Professor of Mechanical Engineering, Columbia University.

S. M. WOODWARD,

M.S., M.A., Irrigation Engineer, Office of Experimental Stations, U. S. Department of Agriculture

Alkali

The Standard Dictionary gives the following definitions:

Alkali is a chemical compound of hydrogen and oxygen with any one of the elements of lithium, sodium, potassium, rubidium, and caesium or the radical ammonium. Alkali is characterized by great solubility in water and capability of neutralizing acids. In popular language the term is extended to anything that will neutralize an acid, such as lime, magnesia, etc.

Aqueous solutions of alkali act corrosively on animal and vegetable substances, and also alter the tint of many coloring matters, as red litmus, which it turns to blue.

Most of the alkalis in our soils have been formed by the washing out of the ashes of sea plants the sodium and potassium.

Alkali-flat is an arid plain, permeated or encrusted with alkali salts, the bed of an evaporated lake.

Alkali-grass, a species of grass *Distichlis*, growing in the alkaline soils of the western part of the United States.

Alkali-land, a region marked by the presence of alkali in the soil, and on the surface.

Alkali-soil, a soil containing an unusual amount of soluble mineral salts. It frequently collects on the surface under

arid conditions and excessive evaporation, and forms a saline crust. The salts as they are found in the soils are generally chloride, carbonates, sulphates, and bi-carbonates of sodium, potassium, magnesium and calcium. Sometimes there are also borates and nitrates. Sometimes alkali is derived by the liberation from the rocks of certain soluble salts, set free by the process of disintegration and soil formation. See *Soils*.

Allspice

Allspice is the unripe fruit of a West Indian tree. It is gathered and dried in the sun, has an aromatic flavor and has been thought to combine the qualities of cinnamon, cloves and nutmeg. Used much in cooking.

Almonds

The almond, *Amygdalus Communis*, grew originally in Barbary and Morocco. Now it is widely cultivated throughout the milder portions of the temperate zones. It is akin to the peach, the prune, the plum and the cherry, yet tenderer than any of these. The writer had an almond tree in his orchard in Yakima county, Washington, which grew vigorously and bore fruit about every second year until it was 12 years of age. The very severe winter of 1908-09 when the mercury ranged for several days about 16 degrees below zero killed the tree. We had in the same orchard peaches, prunes, apricots, plums and cherries and the wood of these trees was not seriously injured, although two degrees to four degrees colder would have damaged the wood of the peach trees. The following year the peaches and apricots bore no fruit of any consequence, but the wood was not injured. The almond tree was injured so that we gave up hope of reinvigorating it and dug it up. Experience has shown that the almond will not stand severe freezing, and therefore is better adapted to warmer climates like California or southern portions of the United States.

It blooms a little earlier than the peach, therefore is more likely to be hurt by early frost. In the spring of 1907 our

almond bloomed about four days earlier than the peaches and earlier than the apricot, plum and prune. Thus it seems impractical to grow the almond for commercial purposes in a climate where the mercury in winter registers as low as 16 degrees below zero, or where there is danger of early frosts killing the buds in the spring time

However, for home use the almond may be grown even where there is considerable hazard, for one or two trees will supply a family with all the nuts they are likely to need. If the fruit is killed on one or two trees, the loss is not very great, or if the trees themselves are killed, the loss is not great, but if a whole orchard is killed, there is not only the loss of the crop for that year, but the loss of time and expense in growing a new orchard. Trees may be protected where nuts are grown for family use; they may be wrapped with paper or with canvas, or canvas may be stretched over the top of one, two or three trees without any very great expenditure of time and money, and thus in a comparatively cold climate almonds may be grown for home use.

The almond can be grown with proper cultivation in semi-arid regions where the rainfall is not sufficient to grow apples, pears, peaches or other fruits, for while it is akin to the peach and its habits of growth are very similar, yet its root system adapts it to a dry climate, and its leaf system evaporates less water than that of the peach. The leaf is small and slender with not a great portion exposed to the air and sunshine, and is so formed that less water evaporates in proportion to the surface than would evaporate from the leaves of other fruits. I have no doubt but that with proper cultivation and care the almond can be grown successfully where there is rainfall sufficient to grow wheat. It should be planted in deep, dry soil, and in an irrigated country should be given less water than other fruits. Another reason for this is obvious when we consider that the fruit of peaches, plums, pears, apples and other varieties is in the pulp which reaches

the highest degree of perfection if they have water enough to make them juicy and luscious, while the fruit of the almond is in the seed, formed very much like the seed of the peach, which is enclosed in a hard shell. The almond shell is soft, and is enclosed in turn in a thin pulpy substance. It takes less water to develop the pit or seed of the almond than it does to develop both the pulp and seed of the peach; therefore, the almond can be grown successfully with less water than is required for almost any other fruit. Experience has shown that if the almond tree is planted in a wet soil, or if it is given too much water, it will not reach its best development, and will not be a long-lived tree.

Species of the Almond

There are two species and several varieties of almonds.

First, there is the bitter almond, which is used in the manufacture of flavoring extracts and of prussic or hydrocyanic acid. When the leaves of the cherry laurel, bitter almond, the kernels of peaches and cherries are distilled in water the distillate contains hydrocyanic acid. It is the most rapid poison known, and causes death within a few seconds. The bitter almond is grown mostly in the countries that cluster around the Mediterranean sea.

Second, the sweet almond, which is divided into two general varieties, the hard shell and the soft shell. The hard shell is considered of little value and is not grown for commercial purposes; while the soft shell, which might be characterized as thin, thinner, thinnest, the last sometimes being called the paper shell almond, is the almond of commerce.

Perhaps no other tree of commerce has been more disappointing in its productive value than the almond. The almond growers of California have probably spent more time and money than any others in experimenting and preparing the way for profitable almond culture, and even now are not quite sure that they have solved the problem; but insofar as they have determined there are three questions that are of great importance:



PLATE I

Fig. 1. Green Apple Aphid. Fig. 2. The Brown Apple Aphid. Figs. 3, 4, 5, and 6. The Woolly Apple Aphid. Figs. 7, 8, and 9. Eggs of the Brown Apple Aphid. Fig. 10. Egg of the Green Apple Aphid. Fig. 11. Egg of Woolly Apple Aphid. Pl. 11.

First, to select varieties that are prolific bearers, for some varieties will not bear fruit enough to pay the cost of cultivation.

Second, to select varieties that cross pollinate, for most varieties of the almond will not pollinate from the same tree.

Third, to select a site for the almond orchard that is as nearly as possible free from frost, because the tree is an early bloomer and the fruit buds are tender.

There are about 25 varieties grown in California and the general treatment and cultivation given to them is similar to that given to the peach.

The almond is propagated by budding on seedling stock, and at maturity the nuts are gathered some time in the autumn. The kernels should be smooth, plump and symmetrical in order to bring the highest price in the market.

Almonds Produced in the United States

There are but few states in the Union which produce almonds for commercial purposes. The number of bearing trees by states, as reported in the census of 1910, gives California 1,166,730; Arizona, 6,639; Utah, 1,408; Nevada, 13. We personally know of a few trees in Washington, and doubtless there are in many other states a few grown for home use. The industry in the other states, however, has not assumed commercial importance.

Varieties

The more important varieties are as follows:

California, California Jordan, Chilinese, Commercial, Drake, Eureka Jordan, Golden State, I. X. L., Languedoc, Lasser, Nonpareil, Prolific, St. Joseph, Texas.

GRANVILLE LOWTHER

ALTITUDE. See *Apple Orchard. Selecting Site For.*

ANTHRACNOSE, TIME TO SPRAY FOR. See *San Jose Scale on Apple*, under *General Recommendations*. See also *Black Spot Canker*.

Aphids

The Aphididae or plant-lice are among the largest families in the great Order Hemiptera. Economically they rank among the groups of the higher importance and few indeed of the higher plants there are that are not subject to their attack. Many of our most injurious forms on fruit trees and truck crops were imported from Europe, while indigenous species include the grape Phylloxera, first imported from wild American vines into France and later from that country into the grape regions of California. Aphids feed solely by means of a stout beak which they thrust into the plant tissue and through which the juices of the plant are sucked up. In certain species this sucking mode of feeding causes the plant tissue to form galls or pseudo-galls in which the lice continue to dwell protected from their foes. Certain other species live on the roots of trees or small plants, but the great majority exist unprotected on the leaves, stems or flower-heads of their food-plants. Many aphids—and among these are a number of very injurious forms—migrate at certain periods from one host plant to another and such hosts may be widely separated botanically. Our knowledge of these migrations and the causes which produce them is as yet far from complete. Most aphids are confined to one host or to several closely related plant species, but a few forms, as for example the Green Peach Aphis (*Myzus persicae* Sulz.), attack a large number and variety of plants. Parthenogenetic reproduction occurs in the vast majority of aphids, although true sexual forms are produced in most species once a year, the sexual female after copulation with the male depositing winter eggs. In some species, especially those inhabiting evergreen plants, it is thought that two or more years may elapse between appearances of the sexed forms, as these forms have failed to appear when expected. Parthenogenetic females are winged and wingless, in some species only the former. Sexed males and females may be winged or wingless, according to species. Lab-

oratory experimenters, working with species having both winged and wingless agamic females, have succeeded in causing the aphids to produce winged forms or only wingless forms at will by subjecting the insects to certain temperatures and by introducing certain chemicals into the food-plants.

Plant-lice increase very rapidly, some species producing 20 or more generations in a single year, each female on arriving at maturity producing in course of time from 10 to 400 eggs or young, as the case may be, and varying with the species. Their numbers are kept in check by a large number of natural enemies. These include parasitic wasps of the families *Braconidae* and *Chalcididae*, and predaceous forms such as lady-bird beetles (*Coccinellidae*), Syrphus-fly maggots (*Syrphidae*), spiders, larvae of lace-wing flies (*Chrysonidae*) and aphid-lions (*Hemerobidae*), and certain predaceous Heteroptera. Ants attend aphids to feed on the sweet substance excreted by them, and in certain forms play the role of husbandmen towards them, carrying them off and caring for them during the winter months.

Bibliography

A complete bibliography of economic plant-lice would occupy too much space for the purpose of this paper. The following references include literature dealing with practically all injurious species:

"Insect Pests of Farm, Garden and Orchard"; E. D. Sanderson (John Wiley & Sons); 1912.

"The Aphides Affecting the Apple"; A. L. Quaintance (U. S. Dept. Agric. Circ. No. 81); 1907.

"The Melon Aphis"; F. H. Chittenden (U. S. Dept. Agric. Circ. No. 80); 1906.

"The Woolly Aphis of the Apple"; C. L. Marlatt (U. S. Dept. Agric. Circ. No. 20); 1908.

"The Pea Aphis"; F. H. Chittenden (U. S. Dept. Agric. Circ. No. 43); 1909.

"Two Plant-Lice of the Peach"; C. P. Gillette and G. P. Weldon (Colo. Agric. Exp. Station, Bull. 169); 1910.

"A Few Orchard Plant Lice"; C. P. Gillette and E. P. Taylor (Colo. Agric. Exp. Station, Bull. 133); 1908.

"The Potato Plant Louse"; E. M. Patch (Maine Agric. Exp. Station, Bull. No. 147); 1907.

"The Corn-Leaf Aphis and Corn-Root Aphis"; F. M. Webster (U. S. Dept. Agric. Circ. No. 86); 1907.

"The Spring-Grain Aphis"; E. M. Webster (U. S. Dept. Agric. Circ. No. 85); 1907.

APPLE

The Green Apple Aphis

Aphis pomi De Geer

This is the green aphid that is often very abundant on the leaves, young shoots and young fruit of apple and pear. It also infests quince, pomegranate and occasionally plum and hawthorn. Its life history is as follows: A week or so before the buds open in the spring the young dark green stem-mothers commence hatching from the winter eggs and for a time feed on tender bark or on the bud scales. After the buds open they confine their attentions to the foliage. In about 25 days the lice are full grown, pale green with a dark head, cornicles and tail. The stem-mother lice are always wingless. Upon attaining maturity they at once begin depositing young, producing within three weeks from 25 to 100 young. A few of the lice of the second

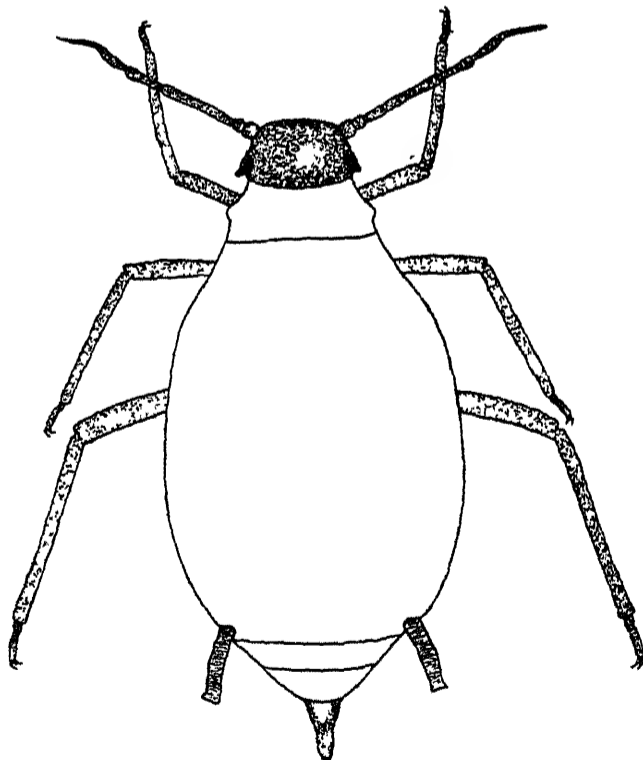

Fig. 1. Wingless Female of Green Apple Aphis. Stem Mother—Greatly enlarged.

—Author's Illustration.

generation will be winged and migrate to other trees, but the great majority will be wingless and remain to colonize the growing shoots. These develop in from 14 to 20 days and when mature immediately deposit young. The lice of the third and subsequent generations during the summer season develop in 10 days. Sometimes winged and sometimes wing-



Fig. 2. Winged Viviparous Female of Green Apple Aphid. Enlarged.

less forms predominate in the summer generations, most of the former migrating to other trees. These generations are all parthenogenetic, that is, the females give birth to their young without the presence of the male element. The young in this case are born alive, or viviparously.

There may be from 10 to 16 such generations in a single season. About the time of the first frosts in the fall appears the sexual generation consisting of a wingless male and a wingless egg-laying or oviparous female. The males are smaller than the other forms of this louse, and are of a yellowish-brown color with dusky appendages and cornicles. The sexual females resemble in size and general appearance the wingless summer forms, but they are dull green with a tinge of rusty yellow. The sexes occur mostly on the under side of the leaves. They mate and the female then lays three or four greenish eggs on the smaller limbs of the tree, generally in



Fig. 3. Eggs of Green Apple Aphid on Apple Twig.

the crotches of the twigs or at the base of a next-year's bud. In a day or two the egg turns a shining jet black.

The summer lice vary considerably in size and in the green shade of the body. The average length of the body of the wingless viviparous lice is 1.75 mm., while that of the winged lice is 1.55 mm. The average egg measurement is .60x.25 mm.

Injury

The Green Apple Aphid attacks leaves, young shoots and fruit. When abundant the lice curl the leaves badly and greatly reduce the size and marketable value of the fruit.

Control

This species can be controlled most easily by the application of winter washes directed against the winter eggs. Home made lime-sulphur, using the 1-1-3 formula, commercial lime-sulphur 1 to 8 or 1 to 10, or a 12 per cent. crude oil emulsion will be found satisfactory as an ovicide. The winter spray should be applied as late as possible before the buds open, as the best results accrue when the trees are sprayed just before the buds begin to open. Against the lice on the foliage spraying should be done directly the lice have all hatched and before they have had time to curl the leaves. Once the leaves have been curled it will be very hard to destroy the lice on them. Whale-oil or fish-oil soap 1 pound to 5 gallons of water, kerosene emulsion 7 per cent, or diluted tobacco extract (Black Leaf "40" 1-1,200, Black Leaf 1-80) is effective. Good pressure is a requisite for the spring applications. Pruning the twigs in winter will destroy a large number of the eggs.

The Rosy Apple Aphid

Aphis sorbi Kalt.

This species occurs on the apple all over the United States. In Europe, its original home, it infests also wild apples (*Sorbus* spp.) and hawthorns. Its life history is not fully known. The stem-mother lice hatch at about the same time as the leaves open out in the spring. They feed on the under side of the leaf and very soon cause it to curl around

them. When full grown the stem-mother is purplish-gray covered with a sparse white bloom and is almost as broad as long. The lice of the third generation are full grown in early June and are all winged pinkish individuals. They

migrate in a body to an alternate host-plant, as yet unknown. In the fall a generation of migrants return to the apple and give birth to the true sexes. Of these the male is black and winged while the female is small and yellowish.



Fig. 4. Green Apple Aphis Oviparous Females and Males on Apple Twig
—Del. Ex. Sta.



Fig. 5. Aphids on Apple Blossom. At O is seen a stem-mother of the Rosy Apple Aphid.—Del. Ex. Sta.

green. The sexes mate and the female deposits about three winter eggs on the twigs or in crevices in the bark of the trunk and large limbs. The injury caused by this aphid is similar to that caused by the Green Apple Aphid. It can be controlled in a like manner.

The European Grain Aphid

Aphis padi L.

Although quite injurious in the eastern United States this species is rarely an apple pest in the West. In color and size it very much resembles the Green Apple Aphid, but may always be distinguished from that species by the very small apical cell of the wing. The life history is very similar to that of the Rosy Apple Aphid, the winter eggs being laid on fruit trees and the summer generations living on grasses. In the South and in California the lice winter also on grasses. When infesting the apple it may be controlled in the manner suggested for the Green Apple Aphid.

The Clover Aphid

Aphis bakeri Cowen

This plant louse infests apple trees in certain portions of the United States,

notably Colorado. Its life history is very similar to that of the Rosy Apple Aphid, the summer generations living on clover and alfalfa. The stem-mother on the apple in spring is dark red or reddish-green while the migrants are pale green with orange spots at the base of the cornicles. The remedies for the Green Apple Aphid will control this aphid on the apple.

The Woolly Apple Aphid

Schizoneura lanigera Hausm.

This is the most injurious aphid infesting pomaceous fruits and is found all over the world wherever apples and pears are grown. It has been known in Europe for over 100 years. It is not known in what part of the world this insect originated but recent investigations seem to show that it is identical with the American Elm-gall Aphid* (*Schizoneura americana* Riley), a native American aphid. The louse attacks the trees below, as well as above, the surface of the ground and is thus very hard to eradicate. The somewhat complex life history is as follows: The young hatch in early spring from winter eggs placed in crevices in

*Edith M. Patch, Maine Bull. 203.

the bark. These immediately seek new tender bark to feed on and their numbers are reinforced by young lice that have hibernated in crevices of the bark under the dead bodies of lice of the previous year, and by an upward migration of lice from the roots. Above ground the only lice that survive the winter are



Fig. 6. Winged and Wingless Female of Woolly Aphis. Much enlarged.
—Author's Illustration.

the very small hibernants of the last summer generation and those hatching in spring from winter eggs. On the roots under a more even temperature the lice live through the winter in comfort. At maturity the lice of the spring and summer generations are all wingless, about one-tenth of an inch long, reddish-brown covered with a white cottony filamentous secretion. The lice are very gregarious and when massed together are often entirely hidden from view by this woolly covering. The wingless forms produce parthenogenetically as many as 100 young in two weeks. These develop in about two weeks. In September a winged gen-



Fig. 7. Elm Leaf Gall or Curl in Which the Winged Aphids Develop Before Flying to the Apple.
—Photo by Maxted.

eration makes its appearance and migrates to other trees. The winged lice are a little shorter than the wingless, are dark brown, covered, all except the wings, with woolly secretion. They produce the true sexed insects on the trunk of the tree. These latter are much smaller than the viviparous forms and have no mouth-

parts. Both sexes are without wings, the orange-colored females being a little larger than the brown males. The sexes become full grown in a week and after mating the female lays a single large egg in a crevice in the bark. The life history of the root form is not fully known. The root lice apparently are all wingless. This louse seems to be capable of passing several years of continuous agamic generations, as the proportion of winged lice is generally very small and consequently there are but few winter eggs deposited each season.

Injury

The root form is especially harmful to young trees and nursery stock, often killing a tree in less than two years from the time of original infestation. Large trees do not succumb so quickly. Infested roots produce knotty swellings and galls which subsequently decay and the lice move to a fresh part. As a rule the root lice work within eight inches of the surface of the soil, a fact that rather simplifies their successful treatment. Above ground woolly aphids occur on any part of the tree except on the fruit. Leaves are usually free from attack. The parts of the tree most preferred are the apices of water sprouts and other young growths; on scars, formed by pruning, between the outer bark and the central woody portion, and at the base of the larger limbs. Limbs and twigs badly infested will become knotted in the same manner as the roots.

Control

The aerial lice may be controlled by any of the contact insecticides suggested for the control of the Green Apple Aphis. High pressure is necessary in order to penetrate the woolly covering, and for this purpose if tobacco extract be employed it would be advisable to add two pounds of fish-oil soap to each 50 gallons of spray. In the spring Tanglefoot bands around the tree trunk will catch the lice migrating upward from the roots. To combat the root form it will be necessary to remove the earth around the tree for a depth of five or six inches so as to uncover a portion of the larger roots and then apply a diluted tobacco extract

(Black Leaf "40" 1 to 800 or Black Leaf 1 to 50). A badly infested tree will require three gallons or more. The lice hibernating on the trunk can be destroyed by a winter application of lime-sulphur. The stock of the Northern Spy Apple is resistant to the Woolly Aphis.

PEAR. See *Apple*.

QUINCE. See *Apple*.

POMEGRANATE. See *Apple*.

PLUM AND PRUNE

The Mealy Plum Aphis

Hyalopterus arundinis Fabr.

This is a longish, rather narrow aphid. It is pale green in color and is covered with a whitish mealy powder. It inhabits the plum during winter and spring, often becoming intensely abundant on the leaves during March and April. In May the great majority of the lice become winged and migrate to grasses, but a few remain on the plum during the



Fig. 8. Galls Caused by Woolly Aphis on Twigs. —Essig



Fig. 9. Effect of Woolly Aphis on Root. —Essig.

summer. Migrants return in October to the fruit trees and produce the sexed forms. The winter eggs are laid on the twigs around the axils of the buds. This aphid is a cosmopolitan species and is probably of European origin, and it and the two following plum plant-lice may be controlled in the manner advised for the Green Apple Aphis.

The Hop Aphis

Phorodon humuli Schrank

This is a pale green non-pulverulent aphid at times injurious to plums. Its life history is similar to the preceding species, the alternate host-plant being the hop.

The Rusty-brown Plum Aphis

Aphis setariae Thos.

This is a small rusty-brown aphid which often infests the young leaves and

shoots of plums in spring. The stunting effect of its injury is sometimes very noticeable on the trees. The summer generations live on grasses.

CHERRY

The Black Cherry Aphis

Myzus cerasi Fabr.

This is a jet black shiny louse with long slender black cornicles. It infests chiefly the heads of young shoots and is often very injurious, checking considerably the growth of the tree. The life history and control are similar to those of the Green Apple Aphis.

PEACH

The Green Peach Aphis

Myzus persicae Sulz.

The majority of the individuals are green or green with black markings, but some are pink, reddish-brown or yellow. This louse measures about one-tenth of an inch in length. No other aphid with such a wide range of food plants as the Green Peach Aphis is known. Its food plants include nearly all deciduous fruit trees, nearly every vegetable, many greenhouse plants and numerous weeds. In Colorado and Missouri it is often quite harmful to peaches and other stone fruits, but on the Pacific Slope it is rarely injurious to fruit trees. The life history is somewhat similar to that of the Rosy Apple Aphis, in that the third generation migrates from fruit trees to weeds, vegetables and greenhouse plants. In the fall occurs a return migration to the fruit trees on which the winter eggs are deposited. In California viviparous lice may be found throughout the year on weeds and in greenhouses. The principal injury occurs to fruit trees in the spring, the lice feeding on the young fruit buds and weakening them to such a degree that they finally shrivel and fall off. Later the foliage will be curled by the lice feeding thereon.

Control

As the lice hatch fully two weeks before the buds open a winter wash may be applied very successfully at this time. The winter sprays recommended for the

Green Apple Aphis are successful in combating this aphid. Black Leaf "40", 1 to 1,000, or Black Leaf, 1 to 70, is also effective. After the trees are in foliage the tobacco extracts may be used effectively, but spraying should not be delayed too long as the lice are very hard to reach once the leaves are curled.

The Black Peach Aphis

Aphis persicae-niger Smith

This is a native American species distributed all over the United States. Both winged and wingless viviparous females are shining black and the young lice are brown. The louse infests roots as well as the aerial portion of the tree. Its life history is somewhat similar to that of the Woolly Apple Aphis. In winter only the wingless root forms exist. Some of these migrate upward in late spring and found colonies on the leaves and shoots. These colonies remain throughout the summer, the winged individuals migrating to other trees. The sexed forms are as yet unknown. The root form occurs chiefly on the smaller and more tender roots and thrives best on light sandy soils.

Control

The aerial lice may be controlled by any of the contact insecticides suggested for the Green Apple Aphis. For the root form the surface soil above the roots should be scraped away and tobacco dust applied. This will be leached down by the rain.

CURRENTS AND GOOSEBERRIES

The Currant Aphis

Myzus ribis L.

This is a small green or yellow louse with black markings which curls the terminal leaves of the shoots of currants and gooseberries. Its life history is similar to that of the Green Apple Aphis. As the lice collect on the under side of the leaves it is necessary to use an under-spray nozzle to reach them. Any of the contact sprays suggested for the Green Apple Aphis may be used but applications should be made before the leaves are badly curled. Very often hand-picking of the curled leaves will suffice to clean up this pest.

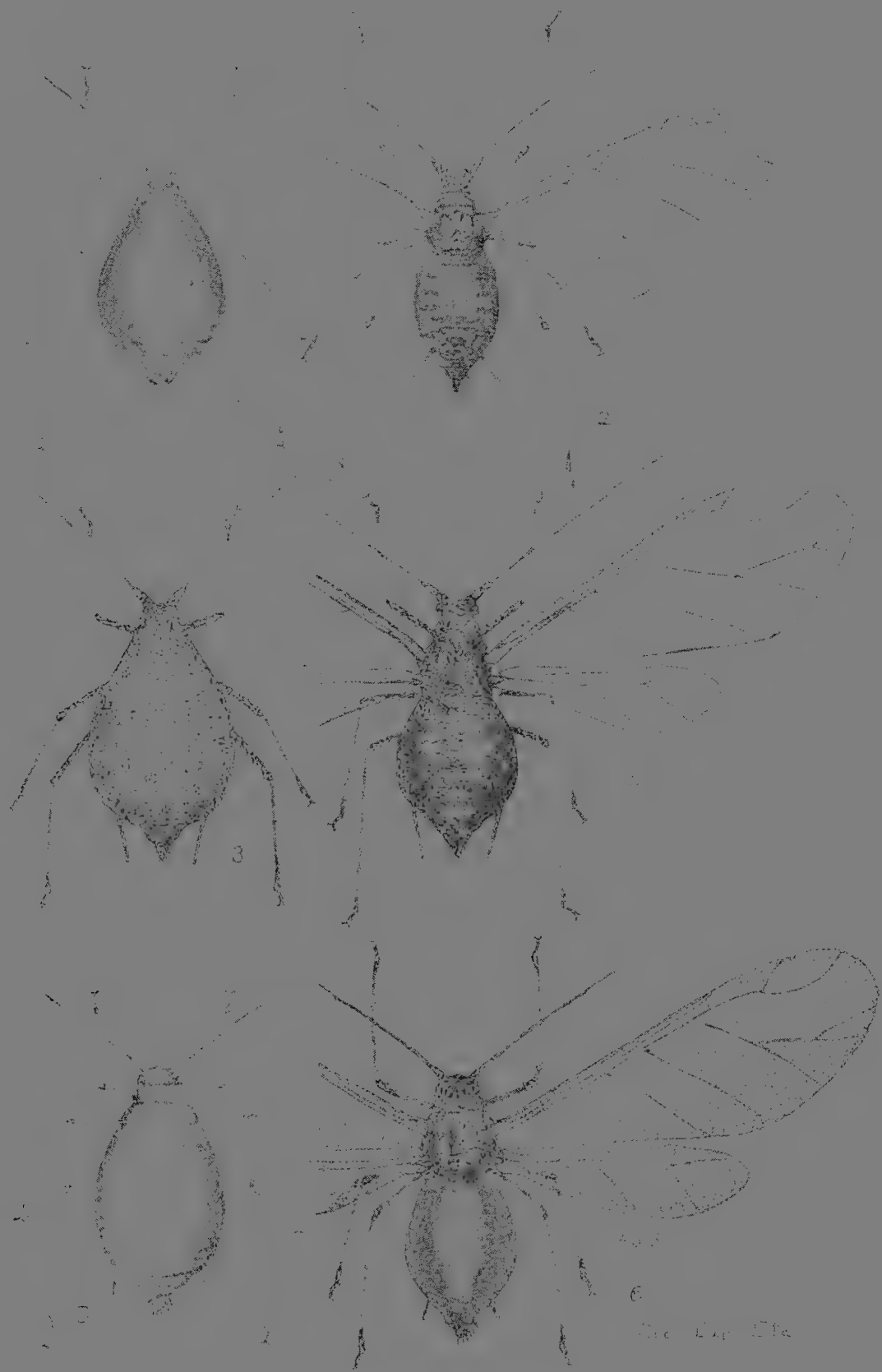

Fig. 1-3. Aphis fabae.

Fig. 1. A. fabae vivipara (Fig. 125, 130, 131, 132, 133, 134, 135, 136, 137, 138, 139, 140, 141, 142, 143, 144, 145, 146, 147, 148, 149, 150, 151, 152, 153, 154, 155, 156, 157, 158, 159, 160, 161, 162, 163, 164, 165, 166, 167, 168, 169, 170, 171, 172, 173, 174, 175, 176, 177, 178, 179, 180, 181, 182, 183, 184, 185, 186, 187, 188, 189, 190, 191, 192, 193, 194, 195, 196, 197, 198, 199, 200, 201, 202, 203, 204, 205, 206, 207, 208, 209, 210, 211, 212, 213, 214, 215, 216, 217, 218, 219, 220, 221, 222, 223, 224, 225, 226, 227, 228, 229, 230, 231, 232, 233, 234, 235, 236, 237, 238, 239, 240, 241, 242, 243, 244, 245, 246, 247, 248, 249, 250, 251, 252, 253, 254, 255, 256, 257, 258, 259, 260, 261, 262, 263, 264, 265, 266, 267, 268, 269, 270, 271, 272, 273, 274, 275, 276, 277, 278, 279, 280, 281, 282, 283, 284, 285, 286, 287, 288, 289, 290, 291, 292, 293, 294, 295, 296, 297, 298, 299, 300, 301, 302, 303, 304, 305, 306, 307, 308, 309, 310, 311, 312, 313, 314, 315, 316, 317, 318, 319, 320, 321, 322, 323, 324, 325, 326, 327, 328, 329, 330, 331, 332, 333, 334, 335, 336, 337, 338, 339, 340, 341, 342, 343, 344, 345, 346, 347, 348, 349, 350, 351, 352, 353, 354, 355, 356, 357, 358, 359, 360, 361, 362, 363, 364, 365, 366, 367, 368, 369, 370, 371, 372, 373, 374, 375, 376, 377, 378, 379, 380, 381, 382, 383, 384, 385, 386, 387, 388, 389, 390, 391, 392, 393, 394, 395, 396, 397, 398, 399, 400, 401, 402, 403, 404, 405, 406, 407, 408, 409, 410, 411, 412, 413, 414, 415, 416, 417, 418, 419, 420, 421, 422, 423, 424, 425, 426, 427, 428, 429, 430, 431, 432, 433, 434, 435, 436, 437, 438, 439, 440, 441, 442, 443, 444, 445, 446, 447, 448, 449, 450, 451, 452, 453, 454, 455, 456, 457, 458, 459, 460, 461, 462, 463, 464, 465, 466, 467, 468, 469, 470, 471, 472, 473, 474, 475, 476, 477, 478, 479, 480, 481, 482, 483, 484, 485, 486, 487, 488, 489, 490, 491, 492, 493, 494, 495, 496, 497, 498, 499, 500, 501, 502, 503, 504, 505, 506, 507, 508, 509, 510, 511, 512, 513, 514, 515, 516, 517, 518, 519, 520, 521, 522, 523, 524, 525, 526, 527, 528, 529, 530, 531, 532, 533, 534, 535, 536, 537, 538, 539, 540, 541, 542, 543, 544, 545, 546, 547, 548, 549, 550, 551, 552, 553, 554, 555, 556, 557, 558, 559, 560, 561, 562, 563, 564, 565, 566, 567, 568, 569, 570, 571, 572, 573, 574, 575, 576, 577, 578, 579, 580, 581, 582, 583, 584, 585, 586, 587, 588, 589, 590, 591, 592, 593, 594, 595, 596, 597, 598, 599, 600, 601, 602, 603, 604, 605, 606, 607, 608, 609, 610, 611, 612, 613, 614, 615, 616, 617, 618, 619, 620, 621, 622, 623, 624, 625, 626, 627, 628, 629, 630, 631, 632, 633, 634, 635, 636, 637, 638, 639, 640, 641, 642, 643, 644, 645, 646, 647, 648, 649, 650, 651, 652, 653, 654, 655, 656, 657, 658, 659, 660, 661, 662, 663, 664, 665, 666, 667, 668, 669, 670, 671, 672, 673, 674, 675, 676, 677, 678, 679, 680, 681, 682, 683, 684, 685, 686, 687, 688, 689, 690, 691, 692, 693, 694, 695, 696, 697, 698, 699, 700, 701, 702, 703, 704, 705, 706, 707, 708, 709, 710, 711, 712, 713, 714, 715, 716, 717, 718, 719, 720, 721, 722, 723, 724, 725, 726, 727, 728, 729, 730, 731, 732, 733, 734, 735, 736, 737, 738, 739, 740, 741, 742, 743, 744, 745, 746, 747, 748, 749, 750, 751, 752, 753, 754, 755, 756, 757, 758, 759, 760, 761, 762, 763, 764, 765, 766, 767, 768, 769, 770, 771, 772, 773, 774, 775, 776, 777, 778, 779, 780, 781, 782, 783, 784, 785, 786, 787, 788, 789, 790, 791, 792, 793, 794, 795, 796, 797, 798, 799, 800, 801, 802, 803, 804, 805, 806, 807, 808, 809, 810, 811, 812, 813, 814, 815, 816, 817, 818, 819, 820, 821, 822, 823, 824, 825, 826, 827, 828, 829, 830, 831, 832, 833, 834, 835, 836, 837, 838, 839, 840, 841, 842, 843, 844, 845, 846, 847, 848, 849, 850, 851, 852, 853, 854, 855, 856, 857, 858, 859, 860, 861, 862, 863, 864, 865, 866, 867, 868, 869, 870, 871, 872, 873, 874, 875, 876, 877, 878, 879, 880, 881, 882, 883, 884, 885, 886, 887, 888, 889, 890, 891, 892, 893, 894, 895, 896, 897, 898, 899, 900, 901, 902, 903, 904, 905, 906, 907, 908, 909, 910, 911, 912, 913, 914, 915, 916, 917, 918, 919, 920, 921, 922, 923, 924, 925, 926, 927, 928, 929, 930, 931, 932, 933, 934, 935, 936, 937, 938, 939, 940, 941, 942, 943, 944, 945, 946, 947, 948, 949, 950, 951, 952, 953, 954, 955, 956, 957, 958, 959, 960, 961, 962, 963, 964, 965, 966, 967, 968, 969, 970, 971, 972, 973, 974, 975, 976, 977, 978, 979, 980, 981, 982, 983, 984, 985, 986, 987, 988, 989, 990, 991, 992, 993, 994, 995, 996, 997, 998, 999, 1000).

STRAWBERRY**The Strawberry Root Aphis***Aphis forbesi* Weed

This species is very destructive to strawberry plants in the eastern and middle western states. The lice, which are greenish-black and about one-twentieth of an inch long, cluster in great numbers on the larger roots. The winter eggs are laid above ground but the lice work chiefly under the surface of the ground and are especially troublesome in light soils. In the control of this aphis several points should be noted: First, plants should not be set out on land infested within the two years previous, as infested roots were probably left in the soil when the plants were pulled up and these remain infested for months; second, plants to be set out, if infested, may be disinfected by being dipped in diluted tobacco extract, provided the winter eggs have hatched; third, straw burnt over the beds just as the plants are beginning to grow in spring will destroy eggs and lice on the leaves and stems. Several species of plant lice occur occasionally on the leaves of the strawberry. These can be destroyed by any of the contact insecticides suggested for the Green Apple Aphis. In Europe *Schizoneura fodiens* Buckt. infests the roots of the strawberry.

BLACKBERRY AND RASPBERRY**The Blackberry Aphis***Amphorophora rubi* Kalt.

This is a large pale green louse with dilated cornicles. It is a European species and occasionally colonizes the growing shoots of blackberries and raspberries in spring. Its life history is not well known. It may be controlled by spraying with whale-oil soap 1 pound to 6 gallons of water.

WALNUT**The European Walnut Aphis***Chromaphis juglandicola* Kalt.

This is a small lemon-yellow species occurring on nuts and leaves of the European walnut. Its life history is similar to that of the Green Apple Aphis

except that the agamic or viviparous lice are all winged. The winter eggs are often laid in crevices of the bark and are thus not easily reached by spraying. The lice on the leaves can be controlled by spraying with a combination spray of dilute oil emulsion and tobacco extract (Black Leaf "40", 1-1,600, or Black Leaf 1-100).

CHESTNUT**The Chestnut Aphis***Callipterus castaneas* Buckt.

This species infests the leaves of commercial chestnuts. In appearance and habits it greatly resembles the walnut louse. Doubtless it can be controlled in a similar manner.

CITRUS TREES

In America five species of plant lice are found on citrus fruits. They are (1) the Citrus Aphis (*Toxoptera aurantiae* Koch); (2) the Cotton Aphis (*Aphis gossypii* Glover); (3) *Aphis cookii* Essig; (4) the Green Peach Aphis (*Myzus persicae* Sulz.); (5) *Macrosiphum citrifolii* Ashm. The first three of these are small dark brown or black insects while the last is a larger pale green form. The Green Peach Aphis will be found described under the article on Peach plant-lice. Occasionally one or more of these lice become abundant on the tender growth of citrus foliage and may do much injury to young buds. As far as citrus trees are concerned the life histories of these species have not been entirely worked out.

Control

Whale-oil soap, 1 pound to 6 gallons of water, 7 per cent kerosene oil emulsion, soap and dilute tobacco extract, or carbolic acid emulsion (diluted so that about 1¼ gallons crude carbolic acid is used to 200 gallons of water) will be found effective washes for citrus plant-lice. A second application may be necessary about four days after the first in order to insure the complete control. High pressure is requisite except for young buds, which should be sprayed with a knapsack or bucket-pump as pressure will knock them off the tree.

PEAS**The Pea Aphis***Macrosiphum destructor* Johnson

This is a large pale green species which winters on clovers and other leguminous plants and migrates to peas shortly after they appear above ground. Sometimes there will be an invasion in the late fall from the wild hosts. This louse is very susceptible to fungus attacks. When abundant the lice are capable of ruining a whole crop in a few weeks.

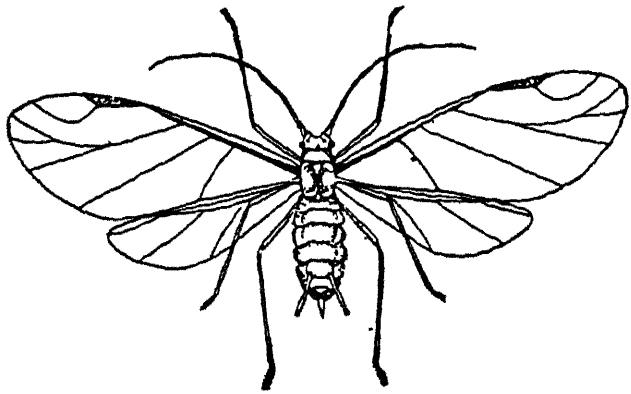

Fig. 10. Destructive Pea Louse. Winged Viviparous Female. Enlarged six times.

Control

Peas grown on well fertilized land are more resistant to the attacks of the aphids, and earlier varieties escape much of the injury. On large areas the best method of control is to brush the lice off the peas with pine boughs and as soon after as possible cultivate down the rows. This will result in the lice being buried in the ground and destroyed. If the soil is dry and hot those lice that are not buried will be killed by the dust closing their breathing pores. The treatment should be repeated every week or more often, until the crop is picked, and is only possible where peas are sown in rows far enough apart to allow of the passage of the cultivator. Another method is to drag long shallow pans in which floats a film of kerosene down the rows and brush off the lice into it. On the terminals the lice will often escape such treatments and spraying with whale-oil soap will destroy many of these. The wild legumes harboring the lice in winter should be destroyed if practicable.

BEAN**The Bean Aphis***Aphis rumicis* L.

This is a small black plant-louse of European origin. The nymphs or pupae have a conspicuous row of white spots on the body. The aphids cluster about the terminal leaves and stalks of the English bean and often attack the pods. The life history is somewhat similar to that of the Pea Aphis. The winter eggs are laid on shrubs such as the snowball plant, the lice migrating in spring to the bean, dock and other plants. The aphid can be controlled by spraying with whale-oil soap (4 pounds to 100 gallons water) combined with tobacco extract (Black Leaf "40", 1 to 2,000) or with flour paste and tobacco extract.

CRUCIFEROUS CROPS**The Cabbage Aphis***Aphis brassicae* L.

This grayish-green mealy aphid occurs all over the United States on cabbages, turnips and related plants cultivated and wild. The winter eggs are deposited on the leaves, the lice hatching therefrom in early spring. In the southern states and in California viviparous lice may be found throughout the year.

Control

The refuse of the crop should be destroyed in the fall. By destroying wild mustard and wild radishes in the vicinity of the cultivated crop migratory infestation will be prevented. The lice can also be controlled by spraying with whale-oil soap 1 pound to 6 gallons of water or with a 7 per cent kerosene oil emulsion.

The Green Peach Aphis*Myzus persicae* Sulz.

During the greater part of the year this pest may be found on a number of vegetables such as cabbage, turnip, celery, spinach and lettuce. It may be controlled in the manner advised for the Cabbage Aphis. See under *Peach*.

BEET**The Beet Aphis***Pemphigus betae* Doane

This is a robust greenish-white or white mealy louse infesting the roots of the beet on the Pacific coast. When in abundance it becomes very injurious, its presence being indicated first by withering and stunted growth of the leaves. The lice attack first the small roots, later moving to the main root and causing it to become spongy. Agamic winged and wingless females occur on the plant the year around and the sexed forms have yet to be found. This species also infests the roots of pigweed, dock and kindred plants. The only known remedy is to discontinue for at least one year planting beets on infested land and to destroy the wild host-plants.

The Beet-root Aphis*Tychea brevicornis* Hart.

This occurs in Colorado on the roots of beets and may be controlled by the discontinuance of planting beets on infested land until such time as is required for the lice remaining in the soil to die of starvation.

The California Beet-root Aphis*Triphidaphis radicolica* Essig

The food-plants and control of this species are similar to that of the Beet Aphis.

CUCURBITOUS CROPS**The Melon or Cotton Aphis***Aphis gossypii* Glover

This aphis inhabits a large variety of plants including cotton, orange, strawberries and most of the Cucurbitaceæ. Its life history is yet imperfectly known. In early spring it migrates from various weeds and shrubs to cultivated plants. Later migrations follow during summer and fall. The progeny of the migrant lice settle in colonies on the under side of the leaves of the cucurbits and soon cause considerable curling. Control measures should be initiated as soon as the pest makes its appearance. Under spraying the foliage with oil emulsions or tobacco extracts is often satisfactory or the plants can be fumigated with

carbon bisulfid or tobacco paper. The carbon bisulfid should be evaporated under a tub or similar tight-fitting receptacle placed over the plant. A dram of liquid may be used for each cubic foot of space. The plants can be fumigated successfully by burning tobacco paper under a canvas frame fitted over the plant. The amount of tobacco paper to be used varies with the cubic measurement of air space under the frame. If the leaves are badly curled fumigation is preferable to spraying.

COTTON

Two species of plant-lice occur on young cotton plants. These are the Melon or Cotton Aphis (*Aphis gossypii* Glover) and the Bur-clover Aphis (*Aphis medicaginis* Koch). Both are small black or dark brown species and inhabit numerous weeds, migrating thence to the cotton plant. The best means of control lies in the prevention of the lice from reaching the cotton and this may be done by ridding the fields of weeds. If melons are planted near the cotton they will prove a continuous source of infestation.

CORN**The Corn-root Aphis***Aphis maidi-radici* Forbes

This aphis is a small bluish-green mealy species. Besides corn it infests sorghum, broom-corn, cotton and grasses. The eggs are laid in the late fall in ants' nests, the egg-laying females having been carried thither by the ants. The young hatching in spring attack the roots of grasses, later migrating to cultivated plants. As the Corn-root Aphis is chiefly troublesome where corn has been planted on the same ground for several years in succession, a rotation of crops will greatly check its ravages. Fertilizing the land with barnyard manure will help the corn to withstand injury, and deep plowing and harrowing in winter will destroy the ants' nests in which the winter eggs are stored besides getting rid of the ant protectors.

The Corn-leaf Aphis*Aphis maidis* Fitch

With the exception of the cotton plant this species has the same range of food-

plants as the Corn-root Aphis. It is about one-twelfth of an inch in length, bluish-green and without bloom. It migrates from weeds to cultivated host-plants in summer and when abundant stunts the plants and causes the leaves to wither and finally die. Injury is heavier on broom-corn and sorghum than on corn. In Texas it has been found on barley in winter. Little seems to have been done on the control of this louse. Whale-oil soap 1 pound to 5 gallons will destroy the aphis, but it is doubtful if this would be practicable in the field on large areas

SMALL GRAINS

Three species of plant-lice, all European, are injurious to small grains. These are: (1) the English Grain Aphis (*Macrosiphum granarium* Buckt.); (2) the Spring Grain Aphis (*Toxoptera graminum* Rond.); (3) the European Grain Aphis (*Aphis padi* L.). These are all bright green forms, the first-named being considerably larger than either of the other two. In the warmer parts of the United States they produce parthenogenetically all the year around on grains and grasses, but in the North winter is passed in the egg stage. The injury they do to young grain plants is often severe, and grain should be watched for their appearance. Small localized outbreaks may be controlled either by plowing under, by covering the spots with straw and burning, or by spraying with whale-oil soap (1 pound to 10 or 12 gallons of water). On large areas of infested grain the only known methods of control are the suppression of all volunteer wheat and oats in the fall, late sowing of fall wheat, and fertilization of the soil to help the plants to resist attacks.

POTATO

The Potato Aphis

Macrosiphum solanifolii Ashmead

This is a large green plant-louse which is occasionally very injurious to the potato in the eastern states. The aphid passes the winter on Shepherd's Purse and other weeds, migrating in spring and summer to the potato and returning in the fall to the weeds. The usual con-

tact insecticides (whale-oil soap, oil emulsions and tobacco extracts) are not practicable against this louse on a large scale but they may be employed with success on a small patch. Control on a large area is reduced to clean culture, fall plowing and the burning over of weedy places in the vicinity of potato fields in order to clean up the land of the alternate host-plants of the aphis.

HOP

The Hop Aphis

Phorodon humuli Schrank

This is a light green non-pulverulent louse originating in Europe and now distributed all over the United States. The winter is passed in the egg stage on plums and prunes, wild and cultivated, the lice migrating in spring to hops. In California researches would indicate that the aphis may pass its whole annual life cycle on the hop, as plums growing in the vicinity of hop-yards badly infested have been carefully examined and found to be totally uninfested by the winter eggs. This plant-louse may be destroyed by spraying with tobacco extract (Black Leaf 1-2,000 to 1-3,000) combined with flour paste (4 pounds to 100 gallons water).

W. M. DAVIDSON

Apple

HISTORY AND ORIGIN

The history of the apple is an interesting illustration of modification through artificial selection. Its history before the period of its domestication is unknown. The best we can do is to point to the wild ancestor and say, "Here is where our particular variety had its origin."

Since the period of its cultivation, however, the changes have been rapid and always in the direction best suited to the wants of mankind. We have studied the habits, adaptations, wants, likes and dislikes of fruits, and more especially the apple, because it is the "King of fruits," and have reduced this study to more or less of a science. We have systems of experimentation and discovery which tend

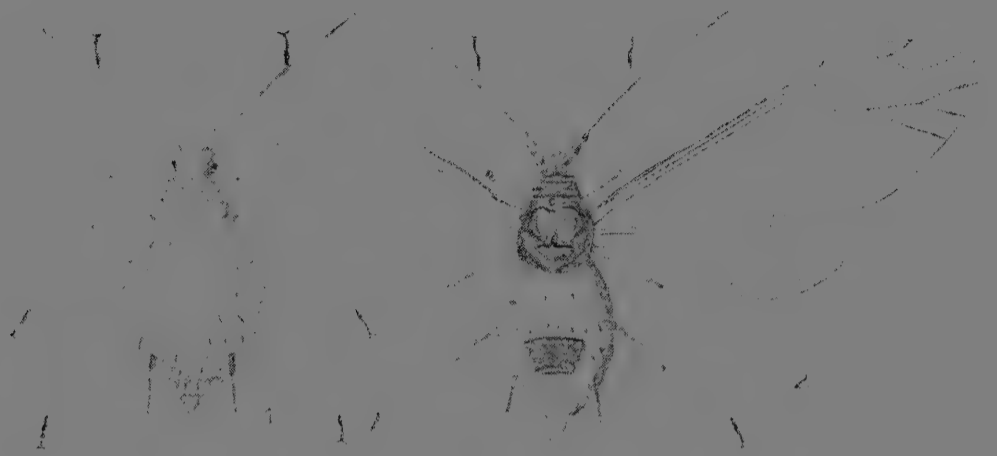

PLATE III

The Green Citrus Aphid, Figs. 1 and 2. The Goussierii Aphid, Figs. 3 and 4.
The Black Birch Aphid, Figs. 5 and 6.

toward a rapid improvement and better adaptation to human needs. So great have been the changes that to the unscientific mind the lowly origin of the apple seems incredible.

The Apple and the Hawthorn

Botanically the hawthorn chokeberries, serviceberries, mountain ash, crab apple and the improved varieties of apples belong to the same family. As a boy in West Virginia the writer saw 100 grafts from a seedling apple inserted in hawthorn stock and a few of them grew. The fact that they lived shows such structural relations as to make reasonable the contention of botanists that they belong to the same group.

The Apple and the Wild Crab

There is now no question among horticulturists that the improved varieties of apple have come from a wild crab discovered originally in the forests of Europe and the Orient.

When the first settlers came to America they found a species of wild crabs growing in the forests and being used by the aborigines for food. When these settlers crossed the Allegheny mountain range and came into the Ohio and Mississippi valleys they found it growing there. In 1865 the writer came to Illinois, settled on the prairies near the eastern border of the state, and found groves of crab trees, hawthorns, plums and cherries scattered along the streams skirting the bodies of timber, and in clumps on the prairies, sometimes not more than a dozen trees in a group, but there they were, with every evidence of having grown there for a long period before the first white settlers came to that country. How they came to be there no one seemed to know, and few cared to inquire. The original settlers took it as a matter of course—the way of nature—and thought no more about it than they did of the larger forests that skirted the rivers or the grass that grew upon the prairie. However, from these wild fruits they made crab apple butter, plum preserves, cherry pies and other delicacies that furnished fruit acids much needed as an

article of food and for the preservation of health.

Varieties of Crabs

There are four varieties of crab apples said to be native to North America.

The first is the Common Wild Crab of the northeastern United States and Canada.

The second is the Narrow Leaved Crab of the middle and southern states.

The third the Prairie States or Souldard Crab.

The fourth the Oregon Crab.

Of these varieties the Souldard Crab is the best. Considerable controversy has grown up as to the origin of the Souldard Crab. Downing in his 'Fruit and Fruit Trees' says: "It originated with Antoine Lessieur, Portage des Sioux, a few miles above St. Louis." The Hon. James G. Souldard of Gibson Illinois introduced it and claimed to be the originator. His account of its origin is as follows: "It originated on a farm about 12 miles from St. Louis, Missouri, where stood an American crab thicket not enclosed near the farm house. The thicket was cut down and the ground cultivated some two or three years. Culture being discontinued another crab thicket sprung up and when bearing one tree, the identical of which is called the Souldard Crab was discovered. The fruit astonished me by its remarkable size. I immediately propagated it by grafting upon crab stock and seedling apples both stocks producing the same fruit."

Mr. Souldard believed it was originated by accidental hybridization with the common apple. Others believe it is a natural variation from the crab. Not knowing the circumstances of this particular case we are not able to offer a solution of the controversy but under the laws of variation now commonly known it might have originated by either of the methods claimed. It seems to us more probable however that it originated by the natural process of variation from the original stock, cultivation having much to do in causing the changes that occurred.

This crab produces apples so nearly in

quality and appearance like some of our seedlings as to show a very close connection between the crab and the seedling. In fact, there are varieties of crabs so nearly like certain varieties of seedlings as to make it next to impossible to determine which is the crab and which is the seedling.

Again it sometimes occurs that seedlings produce the very finest varieties of apples, and by this means domestic varieties have been greatly improved, which tends to establish the fact that apples have followed the law of plant variation in general. This law if wisely used will lead us along a line of indefinite improvement of even the best varieties now grown.

GRANVILLE LOWTHER

BOTANY

The apple tree is a near relative of the roses, raspberries, blackberries, strawberries, and is somewhat further removed from the plums, peaches, cherries, etc. It is therefore a member of the rose family (*Rosaceae*), and has many characteristics common to the one thousand related species.

The place of this family among the flowering plants of the vegetable kingdom has been a matter of some controversy, but the more rational view is the one which regards its species as standing not far from the lower or primitive dicotyledons (*i. e.*, plants with two seed leaves), and hence not distantly related to the buttercups, anemones, etc. Indeed it is not difficult to see in the strawberry, raspberry, and blackberry, and even in the apple itself, a good many resemblances to buttercups and anemones. If the receptacle of a buttercup should become fleshy we would have a pretty close imitation of a strawberry. If we compare the species of *Spiræa* with some of the members of the buttercup family, the resemblance is still more striking. It is safe for us to assume, therefore, that the family of plants to which the apple belongs is not one of high botanical rank, however high we may rank it from an economic standpoint.

In the rose family there are several marked types of flowers, of which the most important are the following: (1.) With several, separate, free pistils, as in the strawberry, blackberry, raspberry, *Spiræa*, etc. (2.) With several pistils which are covered with the adherent calyx-tube, as in the apples, pears, quinces, etc. (3.) With but one free pistil, as in cherries, peaches, plums, etc.

The plants of the second type are sometimes set off in a sub-family called the apple sub-family (*Pomaceae*), and occasionally this has been regarded as a distinct family under the same name. In the apple sub-family botanists have been able to distinguish 14 different genera, of which the most important from the horticulturist's standpoint are the following: *Cotoneaster*, of which one or more species are in common cultivation as pretty, thorn-like trees; *Cydonia*, the quinces; *Pirus*, the apples; *Eriobotrya*, the Japanese medlars; *Amelanchier*, the service berries; *Mespilus*, the common medlars; and *Crataegus*, the hawthorns. In this article we are particularly concerned with the genus which includes the apples, and, as will be seen below, even here we need notice but a few of the many species.

Pirus L

Flowers containing both stamens and pistils; calyx a five-lobed cup adhering to and enclosing the two to five ovaries; petals five, inserted on the top of the calyx cup; stamens many (about 20) inserted on the top of the calyx cup; ovaries usually with two ovules, producing as many seeds; fruit, a pome, consisting of the enlarged and fleshy calyx cup, enclosing the papery carpels (core) and brown, tough-coated seed; leaves alternate, deciduous, simple or compound.

About 50 species of this genus are now known, mostly natives of the north temperate zone, a few extending into the tropics upon high mountains. Seven or eight species occur in North America.

The genus is divided into six subgenera, namely:

1. *The Apples (Malus)*, with globose fruit, containing soft flesh; leaves simple.

2. *The Pears (Eupirus)*, with pear-shaped fruit, containing granular flesh; leaves simple.

3. *The Beam-Trees (Aria)*, with pear-shaped or globose fruit, containing granular flesh; leaves simple.

4. *The Choke-Berries (Aronia)*, with berry-like, pear-shaped, or globose fruits, and simple leaves.

5. *The Dwarf-Apples (Micromeles)*, with small apple-like, two to three celled fruits, and simple leaves.

6. *The Mountain Ashes (Sorbus)*, with berry-like mostly three-celled fruits, and compound leaves.

Here the species of the first sub-genus only will be noticed, inasmuch as they alone are properly entitled to the name "Apple." All the species considered are of more or less horticultural interest.

The Apple Species

SECTION 1. Calyx-lobes persistent upon the ripe fruit; styles five; fruits five-celled.

A. *Leaves folded in the bud, more or less pinnately lobed; flowers white or pink; trees more or less thorny.*

1. Eastern Apple (*Pirus coronaria* L.) Leaves ovate to triangular-ovate, sharply cut-serrate, and often three-lobed; twigs and leaves soon smooth; flowers on smooth pedicels; ripe depressed globose, yellow-green, one to one and one-half inches in diameter. A shrub 8 to 10 feet, or small tree 20 to 30 feet high. Native of North America, from New York to Michigan, and south to Georgia and Alabama, and frequently planted for ornamental purposes.

2. Prairie Apple (*Pirus ioensis* [Wood] Bailey). Leaves elliptic-oblong to ovate-oblong; irregularly and obtusely toothed; twigs and under surface of leaves white-woolly; flowers on white-woolly pedicels; ripe fruit depressed-globose, yellow-green, one to two inches in diameter. A shrub or tree like the preceding. Native of the Mississippi valley. This is probably the parent form of the "Soulard Crab," which Professor Bailey has described as *P. soulardi*.

3. Southern Apple (*Pirus augustifolia* Ait.). Leaves lanceolate-oblong, coarsely

and bluntly toothed, twigs and leaves soon smooth; flowers on smooth pedicels; ripe fruit depressed-globose, yellow-green, three-fourths to one inch in diameter. A shrub or tree like the preceding, native from Pennsylvania to Florida, and west to the Mississippi valley, and frequently planted for ornamental purposes.

It is probable that the three foregoing species are but geographical varieties of one species, as they show easy gradations from one to the other. The Prairie apple appears to be the most valuable, and as a consequence it is the most promising as a stock for the development of cultivated varieties.

B. *Leaves rolled in the bud, not lobed.*

(a.) Fruit crowned by the calyx lobes only (not by a tube).

4. Smooth Wild Apple (*Pirus silvestris* [Mill.] Koch). Leaves ovate, crenate, when young hairy, when old smooth, or nearly so; twigs at first sparsely hairy, becoming smooth, flower-stalk and calyx mostly smooth; fruit yellowish or reddish, three-fourths inch in diameter on a stalk about as long, very sour and bitter. A tree 25 to 30 feet high, native of Central Europe.

5. Hairy Wild Apple (*Pirus malus* L.). Leaves ovate or elliptical, crenate, more or less hairy, as are the twigs also; flower stalk and calyx white-woolly; fruit longer than its stalk, larger than the preceding, from sour to sweet. Two quite well marked wild varieties are commonly recognized as follows:

var. *dasyphylla*, a tree of moderate size with horizontal branches, bearing large leaves (3 to 4 inches long and 2 to 2½ broad). Native of the Orient.

var. *pumila*, a shrub or small tree, native of Southeast Russia, the Caucasus, Tartary, etc. From this variety have come the dwarf apple known as *Paradise* and *Doucain* apples, so frequently used by propagators for dwarfing the larger cultivated sorts.

This species with its varieties appears to have given rise to most of the cultivated apples of the world. It is doubtful whether the preceding species (*P. silvestris*) should be kept distinct from

P. malus. They appear to freely intercross and produce gradations from one type to the other.

The cultivated varieties as the Baldwin, Jonathan, Ben Davis, Grimes' Golden, are what the botanist calls "horticultural varieties," which differ from varieties in the botanical sense by being less stable. A botanical variety will reproduce itself from seed, but these "horticultural varieties" will not do so. And yet the two differ only in degree, not in kind. The horticultural variety is a slight temporary variation which will easily lose its identity, while the botanical variety is the same in kind, but with such stability that it reproduces itself year by year from the seed.

The extremely variable character of this species may be inferred from the statement made by Professor Bailey that the horticultural varieties undoubtedly reach 4,000 or 5,000.* Downing gives descriptions of 1,900 varieties, and the American Pomological Society's list includes 369.

(b) Fruit covered by a short fleshy calyx tube, bearing the calyx lobes.

6. Chinese Apple (*Pirus spectabilis* Aiton). Leaves elongated - elliptical, smooth; flower-stalk and calyx-tube hairy; fruit about as long as its stalk (one inch), yellowish. A tree 20 to 25 feet high, native of China and Japan, often found in cultivation, with much "doubled" flowers.

7. Ringo Apple (*Pirus ringo* Seibold.). Leaves ovate-elongated, sharp serrate, at first hairy below, but eventually smooth; flower-stalk and calyx white-woolly; fruit wax-yellow with a reddish tinge, one to one and one-half inches in diameter, stalk about as long. A small tree nine to ten feet high, native of Japan. Occasionally cultivated for ornamental purposes.

8. Large Siberian Apple (*Pirus prunifolia* Willd.). Leaves ovate, elongated or elliptical, smooth below, on long petioles; flower-stalk and calyx hairy or smooth; fruit wax-yellow, in red and even black, one to one and one-half inches or

more in diameter, stalk about as long or longer. A tree 25 to 30 feet high, native of Northern China, Tartary, and Southern Siberia. This is the parent form of the larger cultivated crab apple, such as the Transcendent, Hyslop, etc

SECTION 2. Calyx-lobes falling off after blossoming; styles three to five; fruits three to five-celled.

A. *Leaves rolled in the bud.*

9. Small Siberian Apple (*Pirus baccata* L.) Leaves elongated-ovate, smooth, as are the twigs also; flowerstalk and calyx smooth; fruit small, one-third to three-fourths inch, yellow or red, on a much longer slender stalk (one to one and one-half inches). A tree 25 to 30 feet high, native of the Himalayas, Amur, China, and Siberia. This is the parent form of the smaller cultivated crab apples, as the Red Siberian Crab, etc

B. *Leaves folded in the bud.*

10. Toringo Apple (*Pirus toringo* Koch). Leaves small, ovate or elongated, three to five-lobed; flower stalk and calyx sparingly hairy, or smooth; fruit small spherical, one-fourth inch in diameter, on a long stalk. A small tree 12 feet high, native of Japan, occasionally planted for ornamental purposes.

11. Oregon Apple (*Pirus rivularis* Dougl.). Leaves ovate-lanceolate, smooth and firm, dark green, serrate; flower-stalk and calyx somewhat hairy, or smooth; fruit on long stalks obovate oblong, one-half to three-fourths inch long, from yellowish-green to yellow and even red, flavor "a pleasant sub-acid." A tree 30 to 40 feet high, native of the Pacific coast of North America from California to Alaska. This species should receive the attention of the scientific horticulturists of the western coast states.

Remarks on the Foregoing Species

From this view of the species noticed above it is seen that three are natives of Eastern North America, one of Western North America, two of Europe, three of China and Japan, and two of the Siberian region. Of these we have brought into cultivation for their fruits one species from Eastern North America, one or two from Europe, and two from the Siberian region. The species from China

*See the article "Apple" in the new edition of Johnson's Cyclopaedia, 1893, pp. 260-261.

and Japan are ornamental, as are also those from North America. These facts may be shown more clearly by the following table

No	Name	Nativity	Cultivated or Not
1	Eastern apple	Eastern North America	For ornament only
2	Prairie apple	Mississippi valley	For ornament and for fruit.
3	Southern apple	Southern states	For ornament only
11	Oregon apple	Pacific coast of North America	Sparsely cultivated for ornament
4	Smooth Wild apple	Europe	Probably cultivated for its fruit.
5	Hairy Wild apple	Europe.	Cultivated for its fruit.
6	Chinese apple	China and Japan	Cultivated for ornament.
7	Ringo apple	Japan	Cultivated for ornament
10	Toringo apple	Japan	Cultivated for ornament.
8	Large Siberian apple	Siberia, Tartary and China	Cultivated for its fruit.
9	Small Siberian apple	Siberia, Amur and China	Cultivated for its fruit.

*Charles E. Bessey, assisted by A. F. Woods, Annual Report State Horticultural Society Nebraska, 1894.

Future of the Native Crab

Although the apple (*Pirus malus*) is not a native of American soil, it seems to find a congenial home here. It is true we have some nearly related species in our native crabs, and they give promise in the hands of the experimenters of better things in the years to come, but as yet no specially valuable varieties have been developed from this source. Our cultivated apples and crabs are the lineal descendants of the wild crabs of Europe, *Pirus malus* and *Pirus baccata*, which have had many years of careful culture bestowed upon them to bring them to our present standard of excellence. When our American species have had as many years of domestic life and as careful culture bestowed upon them they may rival their foreign cousins in many of their good qualities.

G. B. BRACKETT

BEGINNINGS IN OREGON

The Oldest Apple Tree on the Pacific Coast: There stands in the grounds of Old Fort Vancouver, Vancouver, Wash., an apple tree which dates back to the earliest time in the history of white settlements in the Columbia river valley. Bancroft, the historian, tells the following story of the tree:

"At a lunch party in London, about the year 1825, given in honor of some young gentlemen who were about to embark for Fort Vancouver in the employ of the Hudson Bay Company, seeds of fruit, eaten at the party were slipped by some young ladies into the waistcoat pockets of the young men who, upon

their arrival at their destination, gave them to Bruce, the gardener at the fort.

George H. Himes of the Oregon Historical Society is responsible for the following account

Old Vancouver Tree

Regarding the seedling apple which grew near the Hudson Bay Company's Fort Vancouver, now Vancouver, Wash., from seed brought from London to that place in 1825 Mrs. Narciss Prentiss Whitman, one of the two first American women to cross the plains to Oregon, arrived at Fort Vancouver on September 12, 1836, and her husband, Dr. Marcus Whitman, and her traveling companions—Rev. Henry H. Spalding, Mrs. Eliza Hart Spalding and William H. Gray—were entertained by Dr. John McLoughlin, Chief Factor of the Hudson Bay Company. Mrs. Whitman, in her diary under the date above mentioned, made the following entry:

"What a delightful place this is; what a contrast to the rough, barren sand plains through which we have so recently passed! Here we find fruit of every description—apples, peaches, grapes, pears, plums, and fig trees in abundance; also cucumbers, melons, beans, peas, beets, cabbages, tomatoes and every kind of vegetable, too numerous to be mentioned. Every part is very neat and tastefully arranged, with fine walks, lined on each side with strawberry vines. At the opposite end of the garden is a good summer house covered with grape vines. Here I must mention the origin of these grapes.

and apples. A gentleman, 12 years ago, while at a party in London, put the seeds of the grapes and apples which he ate into his vest pocket; soon afterwards he took a voyage to this country and left them here, and now they are greatly multiplied."

J. K. Townsend, an American naturalist, arrived at Fort Vancouver September

16, 1834, and after looking over the farm and examining its products, says: "The greatest curiosity, however, is the apple, which grows on small trees, the branches of which would be broken without the support of props. So profuse is the quantity of fruit that the limbs are covered with it, and it is actually packed together precisely in the same manner that



Fig. 1. Old Apple Tree at Fort Vancouver, Washington, the Seed for Which Was Planted About 1825.

onions are attached to ropes, when they are exposed for sale in our markets."

On December 6, 1835, Dr. Samuel Parker, who arrived at Fort Vancouver several weeks before that date, says: "Fruit of various kinds, such as apples, peaches, grapes and strawberries, for the time they have been introduced, flourish, and prove that the climate and soil are well adapted to the purposes of horticulture."

These references antedate Mrs. Whitman one and two years. Somewhere I have a reference from another source substantially confirming what Mrs. Whitman says about the first introduction of fruit seeds. At the same time, I think it is unsafe to say these seeds were planted before the year 1825. Dr. McLoughlin did not arrive until late in December, 1824.

B. F. Brown established a Nursery on "Puget Sound two miles below Olympia," September 27, 1854.

The Hudson's Bay Company established a branch known as "The Puget Sound Agriculture Company" at Fort Nisqually, Pierce county, now known as Dupont, in 1833. Soon after that date, probably within a year or two, seedling fruit trees were taken there, one or two of which can still be seen or could be seen up to six years ago.

The first grafted fruit in the Puget Sound country was taken there by David J. Chambers in 1849 and 1850, all of which was bought of Luelling & Meek, Milwaukee.

This firm was composed of Henderson Luelling and William Meek, who came across the plains in 1847. Meek was a nursery man and was doing business in Van Buren county, Iowa. He made the acquaintance of Luelling in 1846, and thus learned of his plans for taking a stock of selected fruit trees to Oregon; and not only that, but he made the acquaintance of Mr. Luelling's daughter, and was deeply impressed by her appearance. He returned home and decided that he, too, would take a small stock of fruit trees to Oregon. Accordingly needful preparations were made, and on April 1, 1847, he started to Oregon across the plains and arrived at Oregon

City September 9 following. He drove on at once to the "Forks of the Santiam," a section of county a few miles east of Albany. Here he "heeled in" his trees for the winter. A few weeks later he made it "convenient" to call on Mr. Luelling, below Milwaukee, primarily to see the condition his trees were in, but really to renew acquaintance with the daughter. To his surprise he found Mr. Luelling's trees properly set out and all in good condition. An arrangement was then made to add his trees to the Luelling stock, and thus the firm of Luelling & Meek was formed. And not long after that, having found favor in the eyes of the young lady already alluded to, a second co-partnership was formed, the high contracting parties being Mr. Meek and Miss Luelling.

The partnership with Mr. Luelling continued from 1848 to 1854, when the latter sold out to his brother, Seth, and H. W. Eddy, and removed to California, where he died on December 28, 1878. In 1859 Mr. Meek sold out to J. H. Lambert and removed to Alameda county, California, and carried on fruit growing and general farming until he died in 1882.

Henderson Luelling was born in Greensboro, N. C., April 23, 1809, and his ancestors were Welsh who removed from Wales to North Carolina before the Revolutionary war. His father was a nurseryman in North Carolina, and taught his boy Henderson how to graft as soon as the latter was old enough to whittle. Early in 1831 Henderson Luelling removed to Henry county, Indiana, in the eastern part of the state, not far from Newcastle, and began the nursery business. Soon after establishing himself he acquired a book containing an account of the Lewis and Clark exploring expedition to Oregon in 1804-06, and the reading of that work was what caused him to begin his plans to go to Oregon at some future time. In 1839 he removed to Iowa and engaged in the nursery business, as already indicated, still cherishing the idea of removing to Oregon. At length a plan was evolved which he began putting into execution in 1845, that of making a selection of seeds of what he considered the

best varieties of fruit and planting the same. In the spring of 1846 these rootlets were grafted with especially selected scions, and particular attention was given to their cultivation. Early in April, 1847, a critical selection was made of between 800 and 900 of the best of the trees, one year old from the graft, and they were planted in two wagon boxes in a foot of earth in which was uniformly mixed a lot of pulverized charcoal. A light frame work was built upon the top of each box in order to protect the young and tender limbs from injury by stock. Each wagon was drawn by four yoke of oxen, Mr. Luelling driving the first team and his son, Alfred, a lad of 16, the second team. The trees were watered on the plains as opportunity offered, and the precious load arrived at Portland—then a hamlet in the dense timber containing not to exceed 20 rude log cabins—without any loss worth mentioning. Finding a piece of cleared land about half a mile north of Milwaukee owned by a man named A. E. Wilson, Mr. Luelling bought the tract and at once set out his trees in proper form. Thus was the first fruit nursery on the Pacific coast established. That act gave to Oregon the name of "God's Country, or the Land of the Big Red Apples," a name I used to hear often when I first came to Oregon 59 years ago from Illinois. In the words of Ralph C. Geer, also a pioneer of 1847, "That load of trees contained health, wealth and comfort for the old pioneers of Oregon." It was the mother of all our early nurseries and orchards and gave Oregon a name and fame that she never would have had without it. That load of living shrubs and trees brought more wealth to Oregon than any ship that ever entered the Columbia river. In this connection permit me to say that the source of my information, for the most part, was Alfred Luelling, the son of Henderson, who was his father's chief assistant in the original selection of the varieties, and who attended to all the details of work following until the nursery was an established fact. Further reference to the nursery and to Alfred Luelling may be found on page 95 of the "Proceedings and Papers of the

Twenty-fifth Annual Meeting of the Quarter-Centennial Celebration of the Oregon State Horticultural Society," held at Portland, Ore., November 30, 1910

It occurs to me at this moment that it would be well to say something about Seth *Lewelling*, a younger brother of Henderson *Luelling*. Naturally you will note the difference in spelling the names. The following is the explanation. Originally the name was spelled *Llewellyn* or *Llewelyn*. Henderson's father, so the grandson, Alfred, informed me, dropped the original form and spelled it *Luelling*, and followed that method. All the members of the family followed that style of spelling for many years—indeed until after 1882—and then Seth began spelling his name *Lewelling*, and followed that method until he died February 21, 1896. He was born in North Carolina, March 6, 1819 and in early manhood learned the shoemaker's trade. In 1850 he crossed the plains to California, worked in the mines a few weeks, and then went to Milwaukee, Oregon territory, arriving there November 20, 1850. He worked at his trade as opportunity offered, and in the nursery of his brother, Henderson, between times until November 26, 1853, when he became a partner of the latter for a short time. A little later he began the nursery business on his own account. Seth Lewelling originated the "Black Republican" cherry in the early 60's, the Golden Prune in 1876, and the "Bing" cherry a little later. This cherry was named "Bing" after a faithful Chinaman who had been many years in his employ, and who took great interest in his effort to produce a new and excellent variety of cherry.

The varieties of fruits brought by Lewelling were:

SUMMER APPLES—Sweet June, Red Astrachan, Golden Sweet, Summer Pearmain, Summer Bellflower.

AUTUMN APPLES—Gravenstein, Red Cheek Pippin, Seek-No-Further, Rambo, King of Tompkins County.

WINTER APPLES—Golden Russet, Yellow Bellflower, Tulpehocken, Baldwin, Lady Apple, White Pearmain, Northern Spy, Esopus Spitzenburg, Winesap, Yellow Newtown Pippin, Jennetting.

SUMMER PEARS—Bartlett, Early Butter.

AUTUMN PEARS—Seckel, Flemish, Fall Butter.

WINTER PEARS—Winter Nellis

CHERRIES—Royal Anne, Black Tartarian, Black Heart, May Duke, Kentish.

PEACHES—Crawford's Early, Crawford's Late, Golden Cling.

GRAPES—Isabelle, Delaware, Concord.

Also Siberian Crab Apple and Orange Quince

In this connection it may be stated that the first peaches in the Willamette valley, so far as now known, were grown from pits brought across the plains to Oregon in 1844 by Rev Edward Evans Parrish, who came from Ohio.

Greer's Apple and Pear Seeds

Ralph C Greer, already mentioned, started to Oregon from Knox county, Illinois, and deserves a place in connection with any mention of early fruit growing in Oregon—that is, the original "Oregon County." He brought with him one bushel of apple seeds and half a bushel of pear seeds. These went far towards supplying this coast with trees. He supplied Luelling with stock and Luelling supplied him with buds from his "Traveling Nursery"; thus both were enabled to furnish cultivated trees in great numbers at an early day.

Whitman Apple Trees

Regarding the "Whitman apple trees" in Walla Walla valley, it is the current idea in many quarters that there were fruit trees there at an early date, but in my opinion there is no foundation for that view. I have heard it stated that Whitman brought apple seeds across the plains in 1836. I do not think that was so. It is probably true that he brought garden seeds of various kinds, as mention is made of numerous garden products—corn, vegetables, wheat, squashes, etc—but I have never found any mention of fruit growing at the Whitman mission at any time in any one of the 50 or more letters written by Mrs. Whitman or Dr. Whitman between their arrival at the point selected for their mission station—Wai-il-at-pu, six miles west of the present city of Walla Walla—December, 1836, and on October, 1847. In a

letter dated October 22, 1842, Mrs. Whitman alludes to receiving a keg of fresh apples from Vancouver, and also expresses a wish that dried fruit might be sent out from the East. On April 2, 1846, reference is made by Mrs. Whitman in a letter to buying dried berries from Indians. To my mind these references indicate that no apples were grown at the mission. Of course it is possible that there might have been seedling trees there, secured from Fort Vancouver, which had as yet not begun to bear, and that it is these trees that have been referred to in later years. Rev. Cushing Eells acquired the Whitman mission site early in 1860, and started to that point from Forest Grove, Oregon, on March 10, 1860, arriving there 16 days later. The conditions he found are described but no mention is made of fruit trees. From the foregoing you can readily see why I am in doubt about any early apple trees in the vicinity of the site of the Whitman mission.

Early Orchards on Puget Sound

The early orchards in the Puget sound basin, that is, prior to 1854, as a rule were supplied with stock secured at the Luelling & Meek nursery at Milwaukee. I know of one exception, however, and there may be others. My father brought with him from Illinois a quantity of apple seeds, and we arrived at our destination, four miles east of Olympia, October 21, 1853. He removed from his temporary location to his permanent home on November 9th following. The seeds he brought were planted in boxes that month and set out the following fall in rows, and a year later grafted. A nursery was established at "Eden Farm," near Cowlitz Landing—(in the vicinity of Toledo, Wash., of today)—by Edward D. Warbass, in August, 1854. He got his stock from Morton M. McCarver's nursery, two miles south of Oregon City, Ore, and McCarver got his start from Luelling & Meek. In September, 1854, Hugh Pattison began the nursery business on "Washington Plains," six miles east of Steilacoom, Pierce county, Washington. He secured his stock from Henderson and Seth Lewelling, Milwaukee.

GEO. H. HIMES

The Oldest Orchard in the Yakima Valley

Since the Yakima valley, Washington, on account of the quality of the soil, its climate, and the immense area that is capable of being cultivated to fruits, is already a great fruit growing district, we devote some space to a peculiar characteristic of the soil and climate which has recently been discovered.

It has been supposed that the oldest orchards in the valley were planted about 1875 or 1876; since about that time permanent settlements began to be made, homes to be built, and family orchards to be planted. At this time there was no thought of growing commercial fruits for eastern markets, and ordinarily these orchards were selected by men without experience in orcharding, varieties being chosen to suit the tastes of those who planted them, according to their memories and experiences of the orchards they had known in their home states. These varieties were often unsuited to our climatic and soil conditions, were not of the best commercial sorts, and therefore the old orchards were not highly regarded for their commercial products. These orchards, too, were planted on low lands, that are not now considered the best adapted to the growing of commercial fruits. They were planted where they would grow without irrigation, adjacent to the streams or rivers, because in such locations the trees would get sufficient moisture by the process of sub-irrigation as the water percolated through the sand and gravelly soil of the alluvial bottoms. At this time irrigation had not been introduced, and the only place that trees would live was along the streams or where the orchard could get the seepage from the higher lands. These orchards are mostly standing yet, and are vigorous and healthy, some of the trees almost as large as forest trees. There are pear trees that are two feet in diameter and said, at this writing, to be 35 years old, and apple trees almost as large, but these are not generally of commercial varieties.

However, recently there has been discovered an orchard and its history that

settles a question that is so often asked, "Will the orchards of this country live to be old, and will they continue to bear like some of the older orchards of the eastern states?" Sometimes the question is put in another form something like this, "Will an orchard after it comes into bearing be a profitable investment for a man in his old age, or will it be a profitable heritage to hand down to his children?"

In a general way it is known that peaches, plums, apricots and almonds are short-lived trees, that the Crawford peach will probably live and bear profitably for 20 years, the Elberta 25 years, while pears and apples should live and bear, provided the soil conditions are right, for from 75 to 100 years. The statement as to the long life of the apple and the pear is often doubted, because many orchards are known to be short-lived and observation leads us to the conclusion that we cannot count on profitable returns from an orchard more than 50 years old, and many are unprofitable before they reach that age. This we grant to be true, but if orchards are planted in climates adapted to fruit growing, in soils where there is sufficient plant food, and if they are given enough water, and then protected from insect pests and fungus diseases; and if they are cultivated and pruned, there is no reason why an orchard should not profitably bear for 100 years. Orchards have been planted where there was not enough water and they famished with thirst; we have known them planted where the soil was poor and they starved; we have known others killed by drouth and the hot sunshine of summer; yet there are orchards that live and grow and bear past the 100 year period. (There are orchards in Canada that are more than 100 years old, orchards which are yet bearing. There are orchards in New England, New York and Virginia that are more than 100 years old and some of them in fairly vigorous health. In 1910 I saw exhibited for sale in a store in Syracuse, New York, apples that came from trees a hundred years old. This fruit was not "extra fancy," according to the standards set in the Northwest for commercial fruit.

but the fact that this orchard was bearing at all at such an age was the wonder. Professor Van Deman says that there is an orchard in Ohio planted by his grandfather, which is now in bearing and is 100 years old.)

But the question is asked, "Will orchards on the Pacific coast live as long as it has been proven that they will live on the Atlantic coast or in the eastern or middle states?" There is a general belief that they will, on account of the fact that forest trees have lived to a great age and attained greater size than in most eastern states. But positive proof has been wanting until recently that orchard trees

would do the same. There appears elsewhere an account of the old apple tree at Vancouver, Wash., which was planted in 1826.

At White Swan, about 27 miles southwest of North Yakima and near Fort Simcoe, there is an orchard owned by an Indian called Klickitat Peter, which was planted in 1877.

There is a photograph in circulation showing old Klickitat Peter standing beside one of these trees which is loaded almost to the breaking point. This seems to settle the question as to whether orchards in this country will bear profitably for a long period of time or not.



Fig. 2. Beckwith Apple Tree About 100 Years Old at the Time Picture Was Taken, New York State.

It makes a difference when a young man is planting an orchard for commercial purposes on which he expects to depend in the future for his living, and for a competence in old age, whether that orchard has to be renewed every quarter of a century, or whether it will live a hundred years.

L. V. McWhorter, a writer of Indian history, says:

"Klickitat Peter is about 80 years old; bought those trees on White Salmon at \$2.50 per dozen, planted them 35 years ago. Planted 1877."

It makes a difference in the choice of a location whether a man feels that if he plants an orchard he can gather fruit when he is old and that it will provide for his comfort, and that his children and

grandchildren may gather fruit from the same orchard.

Now let us study the age of this orchard by comparison, for it is by comparisons that we often get more correct views. We have here an orchard that was planted by Klickitat Peter in 1877. It was planted under conditions where there was sufficient moisture and soil substance to furnish it food; it was planted on land where there was seepage from the higher lands above and beyond, and where the roots of the trees could get sufficient moisture. Because of this natural seepage or sub-irrigation there had been growing for centuries, perhaps, considerable crops of grass each year that rotted on the surface of the land and furnished sufficient humus. While it is true

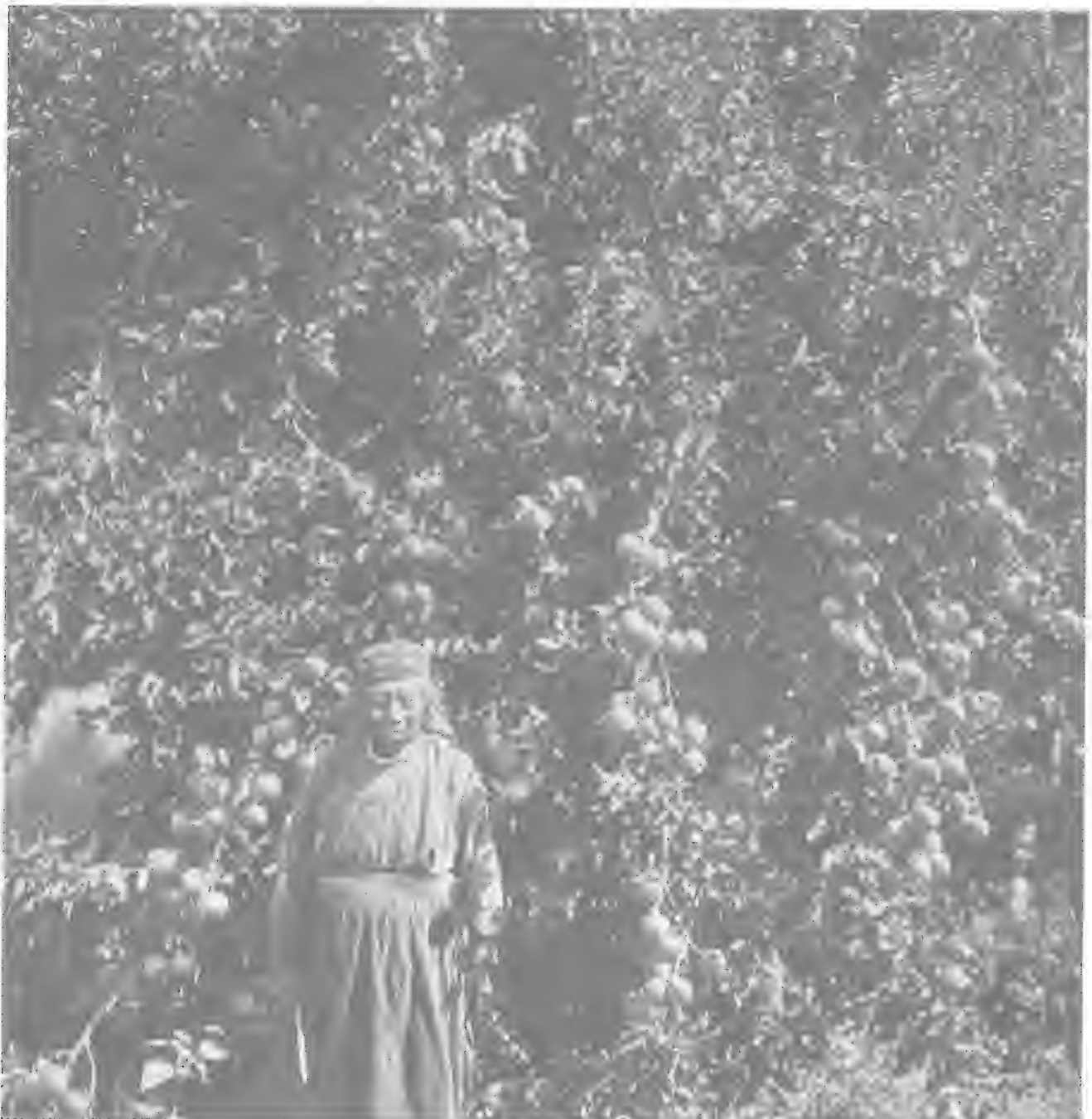

Fig. 3. Wife of Klickitat Peter and One of His Old Apple Trees.

that this orchard has received little or no cultivation, and has not been pruned or sprayed, nevertheless, as shown in the figure (3) the trees are in vigorous health, in full bearing, and the quality of the fruit is good. This orchard was in bearing before the days of railroads in the state of Washington. This seems to establish the fact that trees in this Inland Empire will grow to be old and bear profitably.

Quality of the Fruit

I do not know the variety of the fruit, but the agent of the Oregon-Washington Railroad & Navigation Company, Mr. Kamm, who visited the place and brought home some of the fruit, says that it is of fine quality, and believes that if it had been properly picked and packed it would have contested successfully for the premium at the Washington State Fair.

The lesson we learn is that if we supply our soil with water and with humus and then give the orchards anything like proper care in the destruction of insect pests, there will be a profitable income covering a long period of time.

One of the notable landmarks of the early pioneer days in the John Day valley, Oregon, is the Rhinehart orchard, now more than a half century old. One of the remarkable things about this apple orchard is that, notwithstanding it has neither been cultivated nor pruned, nor in any way cared for beyond what kindly nature has done for it during the past 40 or more years, it is still in comparatively good bearing condition and annually yields a valuable crop of marketable apples of such varieties as the Spitzenburg and Newtown.

It is the largest orchard in the valley, comprising some 40 acres. During all the years of its half century of existence such a thing as a wormy apple has never been found on its trees.

GRANVILLE LOWTHER

APPLE ZONES

The temperate zone is the native home of the apple. All around the world it finds its best general temperature for growth in this zone. In the temperate zone it inclines to the north and finds

there rather than in the south its best or *optimum* condition of growth. In the south temperate zone the apple departs itself much the same as in the north temperate zone and inclines to the cooler south rather than towards the tropical boundary. As an evidence of the hardiness of the apple tree and its love for a cool climate it may be unknown to many that most magnificent apples are grown in Canada, away north of the Great Lakes, on the forty-sixth parallel, north latitude. In this region the lakes and rivers are icebound for several months of the year, the ground in winter is covered with three or four feet of snow and the thermometer is sometimes 30 degrees below zero. In that region the apple is nearing the northern limit of its growth. Considering these extremes of temperature, one would begin to wonder how North Carolina, with its mild climate, could raise apples at all. It does show, however, why apple growing is so commonly unsuccessful in the cotton belt. Being a cool-loving plant, the apple tree finds in the cotton belt its extreme southern limit of endurance. The pecan tree, on the other hand, being a southern neighbor of the cotton plant, will grow and thrive well in the area of cotton production. About one-third of the area of North Carolina is in the cotton belt, one-third rolling piedmont and one-third high and mountainous. It is in this mountainous region of the state, where altitude guarantees a cool climate, that the apple grows and thrives. * * *

Plants, like animals, have their preferences and also their means of showing them. The environmental likes and dislikes of plants are easily seen. When they are at home and comfortable in their surroundings they give evidence of their satisfaction in increased growth and production and in the highest quality of fruit. When they are not comfortable they show a puny growth, scarcity of foliage, susceptibility to the attacks of insects and diseases, lack of fruit and lessened longevity.

It is interesting to note the instinctive desires of the apple tree and what conformity it shows to local conditions. In

the low altitudes where the cotton plant is at home the apple tree is generally most uncomfortable. Except with the early or summer varieties, it is hard in such locations to keep apple trees in life. After resisting conditions unsuited to them they have little power left for fruit production. In the warm, sandy soils where sweet potatoes grow large and sweet, apple trees lose their leaves and

1. Zone Temperate.
2. Climate Summer cool, winter cold.
3. Soil Rich loams and clays.
4. Altitude High.
5. Rainfall Copious and constant.
6. Drainage Good.
7. Sunlight Abundant (air clear and cloudless).
8. Food Constant supply of humus and plant food

In America the regions that produce the most and best apples are those that afford the largest number of these conditions.

Mountain Regions for Apple Culture

* * * The "Sunny South," particularly in its mountain regions, has the clear air and abundant sunlight that put the right colors on the outside of the fruit and the fine flavors within. Other things being equal, the greater the amount of sunlight the higher colored the fruit. In regions where cloudy skies are prevalent fruits and also flowers are of dull colors. Clear, sunny weather will give bright flowers and also highly tinted fruits. The maximum hours of sunlight are obtained at high elevations. It is for this reason that mountain-grown fruit is superior in color and flavor to that of the same varieties grown in the lowlands. The best fruit grown in Eastern United States is that produced on the slopes of the Blue Ridge and Alleghany mountains. The most lofty portions of these mountain ranges are found in Western North Carolina. Here a rich soil, combined with high elevation, affords almost ideal conditions for commercial apple culture. Very few fruit growers in the South appreciate the splendid opportunities afforded for commercial apple growing in the high, cool, but sunny slopes of the Southern Appalachian region. It is only in the last decade or so that fruit growers generally have become aware of the advantage of

have a struggle for life from season to season. On loamy or clayey soils they feel more comfortable, show a correspondingly increased growth and productiveness, are freer from disease and are longer lived. Observations on apple growing throughout the whole of this country show that the trees require for their best growth productiveness and longevity the following conditions:

elevated regions for the commercial growing of hardy fruits. At present all along the eastern slopes and foothills of the Alleghany mountains, in Pennsylvania, in Maryland, in Virginia, in West Virginia and in North Carolina, lands which were formerly considered almost worthless for agricultural purposes are now rapidly passing the mark of \$100 per acre for commercial orcharding.

W. N. HURT, Raleigh, N. C.

THE APPLE INDUSTRY

In this section the statistics of the apple business are given, and a discussion of the general conditions of the industry, by H. P. Gould of the U. S. Department of Agriculture.

Production of Apples in the United States

A statement of the general results of the 13th census relative to the number of farms reporting apple trees of bearing age and those not yet of bearing age, together with the number of trees in each class as of April 15, 1910, and giving the number of bushels of apples produced in 1909 and the value of the crop was issued May 10, 1912, by Director Durand, of the Bureau of the Census, Department of Commerce and Labor. Comparable data are given for 1900 wherever possible.

Decrease in Number of Trees of Bearing Age

At the census of 1900, taken as of June 1, there were reported 201,794,000 apple

trees of bearing age, as against 151,323,000 trees in 1910 (census taken as of April 15), a decrease of 50,471,000 trees, or 33.4 per cent

In 1910 there were 2,980,398 farms reporting the growing of apple trees, or 46.8 per cent of the total number of farms in the United States. The average number of trees per farm reporting is given as 51. No report was received in 1900 showing the number of farms reporting

The returns of the 1900 census likewise did not secure the number of trees under bearing age. In 1910, however, 1,498,746 farms, or 23.6 per cent of the total, had 65,792,000 trees not of bearing age, or an average of 44 per farm

The present census shows that in 1909 there were produced in the United States 147,522,000 bushels of apples, having a total value of \$83,231,000. The production at that time was somewhat less than it was ten years previously, when 175,397,000 bushels were gathered. The reports of the 1900 census give no information as to value of apples.

Number of Apple Trees and Production by Divisions

Of the nine main geographical divisions into which the census divides the country, the East North Central Division in 1910 and 1900 reported the largest number of trees of bearing age, 34,135,000 and 48,493,000, respectively. In 1909 a total of 25,081,000 bushels of apples were gathered, against 47,650,000 bushels in 1899. The value of the crop in 1909 was \$14,669,000.

The division ranking next in the number of trees of bearing age is the West North Central. In 1910 this division had 31,745,000 trees of bearing age, against 43,678,000 trees in 1900. At the present census 22,633,000 bushels of apples were produced by this division, valued at \$11,792,000. Ten years ago the production amounted to 14,321,000 bushels.

The South Atlantic division, with 20,674,000 trees of bearing age, is third in rank. In 1900 the corresponding number of trees was 25,526,000, a slight falling off thus being shown. The trees of bearing age in 1909 produced 18,375,000 bushels valued at \$9,461,000; but in 1899 there were gathered 26,774,000 bushels, the de-

crease during the ten years being 8,399,000 bushels.

The Middle Atlantic division reports almost as many trees of bearing age as the South Atlantic, and shows more apples produced than any of the other divisions. In 1910 there were 20,302,000 producing trees, as compared with 28,640,000 in 1900, the decrease amounting to 8,338,000 trees. The number of bushels gathered in 1909 was 37,865,000, valued at \$19,857,000. In 1899 the trees in this division produced 52,813,000 bushels.

These four divisions reported over 67 per cent of the total product for 1909.

Number of Apple Trees and Production by States

Among the several states, Missouri, New York, and Illinois together contained in 1910 almost 25 per cent of all apple trees of bearing age in the United States.

The number of trees of bearing age in Missouri at the census of 1910 was 14,360,000, this being a decrease since 1900 of 5,680,000 trees. The production of apples in 1909 amounted to 9,969,000 bushels, while in 1900 it was 6,496,000 bushels, a gain of 3,473,000 bushels. The value of the 1909 crop was \$4,886,000.

New York reported 11,248,000 trees of bearing age in 1910, against 15,055,000 trees in 1900. This state alone produced more apples in 1909 than the entire East North Central division, 25,409,000 bushels, valued at \$13,343,000. In 1899, a crop of 24,111,000 bushels was gathered.

In 1910 there were 9,901,000 trees of bearing age in the state of Illinois, while in 1900 the number was 13,430,000 trees. Over 3,093,000 bushels of apples were produced in 1909, against 9,178,000 bushels in 1899, a falling off of over 6,000,000 bushels. The value of the 1909 crops was \$2,112,000.

While the states of Pennsylvania and Michigan did not report as large a number of trees in 1910 as the above-named states, they each produced a considerably greater quantity of apples than Missouri or Illinois.

The Tabular Summary

Further details are shown in the table following:

**Production of Apples in the United States, by Geographic Divisions and States,
Censuses 1910 and 1900**

DIVISION OR STATE	Trees reported April 15, 1910				Products of 1909		Trees re- ported June 1, 1900 (thou- sands)	Products of 1899 Bushels (thou- sands)
	Of bearing age		Not of bearing age		Bushels (thou- sands)	Value (thou- sands)		
	Farms report- ing	Number (thou- sands)	Farms report- ing	Number (thou- sands)				
UNITED STATES	2,980,398	151,323	1,498,746	65,792	147,522	\$83,231	201,794	175,397
GEOGRAPHIC DIV'S:								
New England....	137,765	8,219	45,167	2,095	10,508	\$ 6,273	11,127	11,649
Middle Atlantic.....	378,507	20,302	130,699	5,849	37,865	19,857	28,640	52,813
E. North Central.....	773,570	34,135	372,600	10,610	25,081	14,669	48,493	47,650
W. North Central....	562,827	31,745	288,669	9,725	22,633	11,792	43,678	14,321
South Atlantic.....	496,527	20,674	244,593	10,065	18,375	9,461	25,526	26,774
E. South Central....	363,879	12,273	213,700	5,387	13,163	6,074	19,193	12,410
W. South Central....	160,234	11,838	122,692	7,225	3,240	2,085	11,842	3,086
Mountain.....	36,412	4,615	32,182	6,679	5,718	5,536	4,855	883
Pacific.....	70,677	7,522	48,444	8,157	10,938	7,484	8,440	5,091
NEW ENGLAND								
Maine.....	42,976	3,477	17,362	1,045	3,636	2,122	4,185	1,422
New Hampshire.....	20,420	1,241	5,311	207	1,108	638	2,034	1,979
Vermont.....	23,644	1,184	7,205	220	1,460	752	1,675	1,177
Massachusetts.....	27,937	1,367	9,278	356	2,550	1,780	1,852	3,023
Rhode Island.....	3,327	152	1,005	55	213	147	214	339
Connecticut.....	19,461	799	5,006	212	1,541	833	1,167	3,709
MIDDLE ATLANTIC:								
New York.....	168,667	11,248	48,007	2,829	25,409	13,343	15,055	24,111
New Jersey.....	21,127	1,054	5,851	520	1,407	956	1,811	4,641
Pennsylvania.....	188,713	8,000	76,841	2,501	11,048	5,558	11,774	24,061
E. NORTH CENTRAL:								
Ohio.....	201,044	8,505	77,900	2,438	4,664	2,971	12,953	20,617
Indiana.....	158,104	5,765	74,256	1,962	2,759	1,721	8,625	8,620
Illinois.....	160,215	9,901	60,631	2,548	3,093	2,112	13,430	9,178
Michigan.....	153,026	7,534	87,846	2,253	12,332	5,969	10,928	8,932
Wisconsin.....	101,181	2,430	71,967	1,409	2,232	1,897	2,557	303
W. NORTH CENTRAL:								
Minnesota.....	59,780	1,380	55,340	1,572	1,044	769	876	120
Iowa.....	148,759	5,847	74,687	1,914	6,747	3,551	6,870	3,130
Missouri.....	181,396	14,360	75,035	3,625	9,969	4,886	20,040	6,496
North Dakota.....	1,248	16	3,906	70	4	7	2	1
South Dakota.....	9,316	275	13,510	461	192	159	165	17
Nebraska.....	57,408	2,937	29,920	967	3,321	1,613	3,877	1,343
Kansas.....	104,920	6,930	36,271	1,116	1,356	808	11,848	3,214
SOUTH ATLANTIC:								
Delaware.....	6,741	430	2,231	264	183	115	568	703
Maryland.....	34,798	1,288	17,157	661	1,823	902	1,824	3,151
District of Columbia.....	34	2	3	3	2	1
Virginia.....	115,881	7,005	61,499	3,436	6,104	3,130	8,190	9,836
West Virginia.....	76,122	4,571	46,837	2,772	4,225	2,461	5,441	7,496
North Carolina.....	159,883	4,910	68,268	1,835	4,776	2,015	6,439	4,663
South Carolina.....	40,425	582	20,689	269	363	276	695	252
Georgia.....	62,033	1,878	27,276	822	896	556	2,360	671
Florida.....	610	8	633	6	3	4	8	2
E. SOUTH CENTRAL:								
Kentucky.....	133,037	5,538	68,478	2,106	7,368	3,067	8,757	6,054
Tennessee.....	123,411	4,839	67,350	2,117	4,640	2,172	7,714	5,388
Alabama.....	65,379	1,468	40,979	738	888	621	2,016	719
Mississippi.....	42,052	428	36,893	425	266	214	706	249
W. SOUTH CENTRAL:								
Arkansas.....	67,716	7,650	46,394	3,940	2,296	1,323	7,486	2,811
Louisiana.....	8,885	93	8,082	97	34	29	139	69
Oklahoma.....	47,578	2,956	39,172	2,060	742	573	*2,732	*334
Texas.....	36,055	1,139	29,044	1,128	168	161	1,485	592
MOUNTAIN:								
Montana.....	3,167	697	3,633	1,308	567	567	531	44
Idaho.....	9,414	1,006	9,447	1,540	660	611	982	224
Wyoming.....	737	28	1,175	84	18	38	9	1
Colorado.....	7,986	1,688	6,496	1,973	3,559	3,405	2,005	258
New Mexico.....	5,242	543	5,489	914	417	421	483	142
Arizona.....	822	62	965	54	73	109	46	13
Utah.....	8,419	517	4,631	789	350	320	716	190
Nevada.....	625	74	346	17	74	66	83	11
PACIFIC								
Washington.....	27,156	3,009	21,401	4,863	2,672	2,926	2,736	729
Oregon.....	23,850	2,030	14,327	2,241	1,931	1,657	2,826	878
California.....	19,671	2,483	12,716	1,054	6,335	2,902	2,878	3,484

*Includes Indian Territory.

Apple Shipments, 1911

Reports of apple shipments originating on about one-half of the railroad mileage of the United States from June 1 to December 31, 1911, aggregated 19,000,000 bushels. This total is composed of shipments on roads for which mileage is reported by the Interstate Commerce Commission. A few intrastate railroads and some steamboat lines reported an additional total of 744,838 bushels, but it is not known what fraction of the entire traffic of such roads and boat lines this figure represents. Of the interstate railroads, reports were received from those operating a total of 127,751 miles, or 52.3 per cent of the entire mileage operated in the United States on June 30, 1909. To avoid duplication each road was requested to report only shipments originating on its own lines.

This, the first of a series of annual reports on this subject, has the disadvan-

tage of not having similar returns for an earlier year for comparison. The returns for the second year, 1912, will naturally be more useful.

The figures given below contain some duplication, due to apples which were shipped to storehouses and afterwards reshipped. The shipments as reported do not include those made from producing points after December 31, 1911, except for a few railroads. Among the railroads failing to report are a few of the more important ones in New York. For other parts of the United States it is not known whether the roads not reporting had generally more or less traffic in apples than the roads that did report. If it is assumed that for the entire country, including New York, the traffic was in proportion to the mileage, the total apples originating on interstate railroads in the United States from June 1 to December 31, 1911, would be over 37,000,000 bushels.

Apples Shipped from Points on Interstate Railroads in the United States, June 1 to December 31, 1911

(Original shipments only; excluding receipts from other carriers. Excluding, in the case of many roads, shipments in less than carload lots.)

Group ¹	Miles operated by railroads, June 30, 1909			Apples originating on railroads	
	Total	Reporting as to apples		As reported	Total, as computed on basis of mileage ²
		Miles	Per cent of total		
I.....	8,152	4,569	56 0	Bushels 1,917,931	Bushels 3,424,877
II.....	24,510	9,743	39 8	3,294,601	8,277,892
III.....	26,483	12,557	47.4	2,431,813	5,130,407
IV.....	15,106	9,391	62.2	1,346,839	2,165,336
V.....	29,282	15,788	53 9	119,261	221,263
VI.....	52,209	26,541	50.8	2,933,812	5,775,220
VII.....	12,995	8,017	61.7	284,037	460,352
VIII.....	33,981	22,447	66 1	2,628,969	3,977,260
IX.....	18,707	6,264	33.5	30,415	90,791
X.....	22,659	12,434	54 9	4,112,573	7,491,026
United States	244,084	127,751	52 3	19,100,251	37,014,424

(1) Group I comprises the railroads of the New England States; Group II, New York (east of Buffalo), Pennsylvania (east of Pittsburgh), New Jersey, Delaware, Maryland, and northern part of West Virginia; Group III, New York (west of Buffalo), Pennsylvania (west of Pittsburgh), Ohio, Indiana, and the southern peninsula of Michigan; Group IV, Virginia, Central and Southern West Virginia, North Carolina, and South Carolina; Group V, Kentucky, Tennessee, Georgia, Florida, Alabama, Mississippi, and Louisiana (east of the Mississippi river); Group VI, northern peninsula of Michigan, Wisconsin, Illinois, Minnesota, Iowa, Missouri (north of the Missouri river), North Dakota (east of the Missouri river), and South Dakota (east of the Missouri river); Group VII, North Dakota (west of the Missouri river), South Dakota (west of the Missouri river), Nebraska, Montana, Wyoming and Northern Colorado; Group VIII, Missouri (south of Missouri river), Arkansas, Kansas, Oklahoma, Central and Southern Colorado, North-eastern New Mexico, and the "panhandle" of Texas; Group IX, Texas (except the "panhandle") and Southeastern New Mexico; Group X, Idaho, Utah, Nevada, Western New Mexico, Arizona, Oregon, Washington, and California.

(2) Figures in this column are based upon the two preceding columns and are subject to more or less error, depending upon how well the apple traffic of reporting railroads represents proportionally that of the non-reporting railroads.

(3) Obtained by addition.

Summary of Exports of Domestic Apples, Green or Ripe, Years Ending
June 30, 1906—1910

Exported to	1906	1907	1908	1909	1910
	Barrels	Barrels	Barrels	Barrels	Barrels
Europe	1,135,997	1,399,276	941,366	730,794	765,686
North America	48,438	95,190	78,351	110,956	119,282
South America	5,816	9,356	7,923	9,131	12,937
Asia	3,454	7,235	5,164	8,571	6,300
Oceania	15,230	27,928	16,738	36,526	17,873
Africa	54	282	3		..

Exported	1906	1907	1908	1909	1910
	Dollars	Dollars	Dollars	Dollars	Dollars
Europe ..	3,503,506	4,234,104	3,275,445	2,300,054	2,601,025
North America	182,619	307,831	300,309	349,280	465,794
South America	20,106	28,222	25,353	27,616	46,310
Asia	10,649	26,144	20,022	23,283	18,367
Oceania	34,235	55,863	39,715	81,774	43,937
Africa	260	802	10		..

Summary of Exports of Domestic Dried Apples, Years Ending June 30, 1906—1910

Exported to	1906	1907	1908	1909	1910
	Pounds	Pounds	Pounds	Pounds	Pounds
Europe .	26,974,352	44,189,854	23,483,768	32,686,171	23,337,389
North America	163,862	644,638	164,153	159,052	211,559
South America	51,550	68,698	78,003	77,370	98,260
Asia	166,855	199,562	121,299	160,744	90,910
Oceania	107,788	356,801	200,650	159,338	152,780
Africa	388,424	238,395	190,000	231,959	185,720

Exported to	1906	1907	1908	1909	1910
	Dollars	Dollars	Dollars	Dollars	Dollars
Europe	1,961,479	3,048,223	1,878,080	2,277,400	1,991,339
North America	14,224	45,415	14,157	11,263	17,376
South America	5,221	6,559	7,713	6,920	9,012
Asia	14,730	16,129	9,815	12,211	8,346
Oceania	10,538	25,470	17,385	11,019	12,276
Africa	38,628	25,150	19,660	21,123	18,343

Exports of Boxed Apples for Season 1911-12 from New York *

Date	Liverpool	London	Glasgow	Hamburg	Bremen	Manchester	Various	Total
	Boxes	Boxes	Boxes	Boxes	Boxes	Boxes	Boxes	Boxes
September 1911	656	776						1,432
" 2.....	60	1,104					300	1,464
" 9.....	1,896	1,319	698					3,913
" 16.....	1,537	2,972	1,130					5,639
" 23.....		6,584	781					7,365
" 30.....		2,326		725				3,051
October 7.....	640	7,109	630	2,855				11,234
" 14.....	4,884	9,446	680	4,145				19,155
" 21.....	7,999	2,920	1,890	5,886			1,904	20,599
" 28.....	5,903	4,450	780	6,014				17,147
November 4.....	6,417	6,941	371	7,708	200		1,920	23,557
" 11.....	2,624	4,281	303	4,384			3,240	14,832
" 18.....	9,004	5,225		2,096	1,478		177	17,980
" 25.....	7,989	3,666	2,409	1,290			2,536	17,890
December 2.....	6,689	13,186		692	300		3,729	24,596
" 9.....	4,074	3,869	915	637				9,495
" 16.....	2,771	7,593	640	707			1,242	12,953
" 23.....	7,516	10,195		1,875			1,270	20,856
" 30.....								
1912								
January 6.....	4,690	5,391	3,601	2,294				15,976
" 13.....	2,379	4,640		4,112	2,484		100	13,715
" 20.....	6,776	5,964	640					13,380
" 27.....	5,617	3,878	1,768	3,238			632	15,133
February 3.....	7,849	1,553	1,218	4,922			760	16,302
" 10.....	6,202	2,184	150	2,608	1,534			12,678
" 17.....	8,824	6,096			1,838			16,758
" 24.....	7,751	7,506		2,616	629	2,000		20,502
March 2.....	8,875	10,821		2,769			1,300	23,765
" 9.....	8,110	4,474	5,008	509	1,268			19,369
" 16.....	11,367	3,680	7,849	4,670		530	1,100	29,196
" 23.....	3,709	2,460	6,240	604	751			13,764
" 30.....	5,410			3,278			600	9,288
April 6.....	1,294	680						1,974
" 13.....								
" 20.....	1,320							1,320
Totals.....	160,832	153,289	37,701	70,634	10,482	2,530	20,810	456,278
Boston.....	28,502	72,805	6,541			22,909		130,757

(* Compiled by Mahlon Terhune Produce Exchange, New York, by permission.)

Comparisons With Other Seasons

Date	Liverpool	London	Glasgow	Hamburg	Bremen	Hull	Various	Total
1899-00.....	58,992	70,724	13,118	1,925		4,826		149,515
1900-01.....	61,602	107,752	22,415	1,325		7,000		200,094
1901-02.....	109,715	153,653	20,449	2,929		9,681		296,427
1902-03.....	69,020	126,730	11,722	488		4,629		212,587
1903-04.....	107,260	188,643	24,302	23,486		19,814	25,470	388,975
1904-05.....	17,154	32,254	24,484				13,420	87,321
1905-06.....	131,172	196,516	24,067	14,938	13,025	20,657	15,371	415,740
1906-07.....	87,067	128,024	10,307	3,878			22,735	252,011
1907-08.....	98,609	151,363	11,958	2,208			21,068	285,206
1908-09.....	208,383	243,969	41,708	3,263	17,858	3,198	2,413	520,792
1909-10.....	170,139	249,990	48,054	22,516	21,883		18,152	530,734
1910-11.....	361,268	501,964	94,465	77,981	18,386		52,546	1,106,610
1911-12.....	189,334	226,094	44,242	70,634	10,482		46,249	587,035

APPLES

APPLE EXPORTS FOR SEASON 1911-12

Date	PORTS OF EXPORT								PORTS OF IMPORT						Total
	New York	Boston	Mon-treal	Port-land	Halifax	St. John	An-napolis	Liver-pool	London	Glasgow	Ham-burg	Man-chester	Various		
	Barrels	Barrels	Barrels	Barrels	Barrels	Barrels	Barrels	Barrels	Barrels	Barrels	Barrels	Barrels	Barrels	Barrels	
1911															
July 29	27									27				27	
August 5	178	149						149		178				327	
August 12	1,423	333	206					1,034	206	722				1,962	
August 19	4,851	150	800					150		5,651				5,801	
August 26	3,111	1,516	672					771		4,528				5,299	
September 2	4,103	884			21,957			1,657	16,686	8,225			376	26,944	
September 9	6,636		4,156		32,456			30,280	30,095	7,180				43,245	
September 16	9,812	2,093	13,186		63,254			5,873	34,320	13,857			602	88,345	
September 23	20,378	4,338	16,967		24,084		9,074	15,970	44,587	441			12,046	74,841	
September 30	20,104	6,794	24,030		63,611			35,986	29,590	36,269			2,905	114,539	
October 7	22,342	5,875	27,955		66,312			36,576	35,992	40,376			8,331	122,484	
October 14	28,948	28,677	35,876		75,651		8,500	64,032	37,881	52,235			20,836	177,652	
October 21	38,158	33,039	35,607		52,902			63,590	38,789	34,477			6,820	159,726	
October 28	41,829	31,530	40,703		52,354			54,898	1,939	37,904			11,581	166,416	
November 4	35,840	29,174	14,927		37,961			42,688	29,906	35,208			9,539	127,170	
November 11	30,340	41,024	14,927		57,128			36,881	33,395	13,915			5,420	143,419	
November 18	20,790	31,439	10,060		51,867	851		36,843	35,759	25,021			2,800	140,345	
November 25	20,100	42,826	15,738		59,137	733		61,965	5,885	10,483			5,449	95,310	
December 2	17,100	31,680	5,873		59,137	3,003		62,676	37,751	23,482			12,113	155,187	
December 9	18,506	27,533			56,055	3,432		39,176	41,062	37,917			2,991	122,918	
December 16	5,835	2,200			42,176	678		9,067	1,506	19,858			4,635	57,430	
December 23	6,640	22,849			11,297	1,400		29,877	15,728	4,586			8,386	58,883	
December 30	14,122	9,977			55,159	4,320		37,421	49,295	1,996			6,927	97,722	
1912															
January 6	13,993	5,215			55,517	1,293		28,790	34,120	13,955			458	93,545	
January 13	7,900	3,486			27,779	609		19,071	20,064	4,881			861	47,984	
January 20	15,634	14,089			18,242			28,056	9,014	12,680			195	58,933	
January 27	24,850	2,849			50,842	505		19,307	35,950	9,083			350	88,414	
February 3	19,901	6,194			25,344	678		27,109	15,833	10,165			1,072	62,904	
February 10	13,472	10,419			41,860	3,142		35,275	41,963	6,392			663	86,947	
February 17	9,803	4,713			34,015	1,547		25,327	9,682	2,392			959	58,785	
February 24	13,429	11,066			31,024	1,303		23,611	28,250	8,428			875	61,164	
March 2	13,522	9,400			42,392	1,012		32,527	33,901	8,576			1,455	76,805	
March 9	15,464	9,990			5,890	318		12,538	6,404	5,805			3,417	34,847	
March 16	12,411	1,965			30,581	1,036		6,212	31,790	6,600			1,342	48,355	
March 23	5,092	4,860			4,472	2,406		4,392	820	4,059			2,081	25,018	
March 30	3,319	3,123			7,520	1,129		4,947	8,186	629			200	15,091	
April 6	1,091	3,763			2,090	1,217		11,162	615	1,858			1,670	15,305	
April 13	160	1,373			1,973	125		4,175	142	125			3,493	4,317	
April 20	440	1,080						1,753	1,740					3,493	
April 27														125	
Total	551,663	447,685	270,951	236,602	1,222,815	30,737	17,574	962,262	756,056	537,306	283,065	92,883	136,455	2,768,027	
†Boxes	456,278	130,757						189,334	226,094	44,242	70,634	25,439	31,092	587,035	

†Note. These figures are included in the above shipments, three boxes to barrel.

COMPARISON OF SEASONS 1880-81 TO 1911-12

Date	PORTS OF EXPORT										PORTS OF IMPORT					Total
	New York	Boston	Mon-treal	Port-land	Halifax and St. Johns	Phila-delphia	Balti-more	New-port News	Nor-folk	An-napolis	Liver-pool	London	Glasgow	Han-burg	Various	
1880-81.....	599,200	510,300	145,276	39,908	24,250	9,972	839,444	177,936	216,301	95,036	1,328,806
1881-82.....	75,889	65,093	56,433	6,497	13,805	21,535	133,784	46,147	59,266	55	239,252
1882-83.....	169,570	102,409	64,190	16,890	18,542	3,900	19,893	253,432	46,975	81,269	13,318	395,594
1883-84.....	53,048	7,145	7,445	9,811	3,758	325	46,661	4,843	29,685	343	81,532
1884-85.....	256,314	307,130	84,487	71,460	41,207	8,612	491,898	123,081	137,631	16,590	769,210
1885-86.....	466,203	221,724	68,716	87,301	37,982	186	3,161	537,695	147,102	170,445	24,031	885,273
1886-87.....	175,595	303,479	106,713	100,569	94,606	26,965	468,553	138,756	170,445	12,775	807,924
1887-88.....	275,696	163,916	93,058	25,215	32,652	17,884	346,557	104,072	139,517	18,275	608,421
1888-89.....	474,337	382,199	201,307	145,825	94,691	860	18,190	790,502	279,374	272,068	64,465	1,407,409
1889-90.....	169,557	132,589	102,526	122,433	53,627	37,030	418,850	128,248	116,449	14,115	677,762
1890-91.....	76,503	23,123	182,095	80,365	89,190	252,548	116,705	80,772	1,260	451,285
1891-92.....	537,247	339,964	320,457	163,145	87,379	550	917,535	224,356	282,553	25,892	1,450,336
1892-93.....	218,037	204,138	429,243	235,395	116,725	798,291	174,405	220,790	10,052	1,203,538
1893-94.....	29,396	4,796	56,255	49,344	35,058	101,205	32,581	38,524	2,530	174,841
1894-95.....	221,398	523,123	273,353	155,878	264,410	853,198	388,535	173,312	23,110	1,438,155
1895-96.....	230,705	84,771	128,027	141,955	165,797	410,596	196,184	127,942	16,533	751,255
" Boxes.....	13,610	1,861	11,342	2,458	1,771	15,471
1896-97.....	570,327	1,015,029	700,274	221,350	409,733	3,133	1,581,560	716,771	411,575	92,835	2,919,846
1897-98.....	361,894	176,322	163,313	126,261	82,208	3,943	490,138	198,281	123,828	12,969	913,996
1898-99.....	158,213	237,395	404,573	143,892	277,014	689,036	271,342	180,336	57,512	1,221,087
" Boxes.....	176,107	4,529	1,349	81,484	87,188	9,226	2,556	181,985
99-1900.....	306,889	177,660	285,528	148,892	360,799	644,857	319,869	211,555	44,690	1,293,121
" Boxes.....	149,515	58,922	70,724	13,118	1,925	149,515
1900-01.....	240,635	409,979	249,219	225,396	200,000	814,100	251,322	225,061	28,919	1,346,030
" Boxes.....	203,333	60,776	111,307	22,925	7,000	203,333
1901-02.....	296,427	143,851	122,465	100,419	271,230	408,655	229,808	129,312	6,077	792,128
" Boxes.....	732,764	109,715	153,653	20,449	9,681	296,427
1902-03.....	212,587	838,815	476,425	338,080	156,675	1,445,347	457,778	398,271	94,692	2,542,759
" Boxes.....	1,120,284	69,020	126,730	11,782	488	212,587
" Boxes.....	388,975	1,616,037	869,572	474,950	261,568	3,505,334
1904-05.....	654,443	680,398	375,085	304,921	372,369	1,130,220	552,692	394,090	176,053	2,411,623
" Boxes.....	66,001	17,154	32,254	24,484	87,321
1905-06.....	609,847	440,440	551,914	247,516	336,414	943,652	486,657	351,375	223,652	2,186,131
" Boxes.....	416,266	127,199	196,372	24,067	53,972	416,266
1906-07.....	668,866	521,241	399,161	375,345	342,476	1,084,810	464,240	404,838	189,678	2,307,089
" Boxes.....	252,011	87,067	128,024	10,307	22,735	252,011
1907-08.....	484,779	431,852	624,159	423,929	504,809	1,179,323	593,110	445,726	146,487	2,469,528
" Boxes.....	285,206	98,609	151,363	11,958	2,208	285,206
1908-09.....	363,327	188,914	353,146	89,403	560,887	674,700	406,253	341,389	142,363	1,572,615
" Boxes.....	520,792	208,383	243,969	41,708	3,263	520,792
1909-10.....	398,944	263,623	587,287	240,820	682,515	878,052	615,354	452,853	192,224	2,212,474
" Boxes.....	460,362	145,486	211,873	45,388	35,099	460,362
1910-11.....	651,738	487,896	172,729	110,339	211,275	649,055	446,672	324,876	142,601	1,634,977
" Boxes.....	959,980	361,268	501,964	94,465	77,981	1,106,610
1911-12.....	551,663	447,685	270,951	236,602	1,271,126	962,262	756,056	537,306	229,338	2,768,027
" Boxes.....	456,278	189,334	226,094	44,242	56,531	587,035

THE PRESENT STATUS OF THE APPLE INDUSTRY

There is probably no branch of agriculture that has developed in the past 20 years under such an impetus as has the fruit industry. It has developed in a quarter of a century from a more or less general and relatively unimportant line of agriculture to a very highly specialized line of great importance. Within this period the operation of spraying for insect pests and fungus diseases has been developed without which, commercial fruit growing, at least commercial apple growing as we know it today, would be an impossibility. Without spraying pests and fungi would reign supreme in every orchard.

During the past 20 or 25 years fruit growing has been extended to practically every section of our country. In some sections where, 25 years ago, fruit culture was not thought of as a possibility and where even its suggestion was a matter of ridicule, men are now finding fruit growing profitable.

In the case of the peach, for instance; instead of its production being confined to a narrow strip along the lake-shore of Michigan and to New Jersey, Delaware and the eastern shore of Maryland, as was the case not very many years ago, the peach is now produced commercially to some extent in practically four-fifths of the states in the Union. In other words, instead of being adapted only to the peculiar conditions of a few restricted areas, the experience of later years has demonstrated that with suitable varieties and proper cultural methods peaches may be successfully grown under a very wide range of conditions. And so it is with many other fruits.

We very commonly refer to the "present status of fruit growing." What is the "present status"? What is the road that has been traveled in the present development of fruit culture? Whither are we bound in its future development?

The presentation in this connection of a few significant points of an historical nature might be of interest, showing as they do something of what the "present

status" of fruit growing is in contrast with past stages of its development.

American pomological literature is only about 100 years old and in the first book* relative to fruit growing and gardening that was published in America, Bernard M'Mahon, its author, makes these interesting statements: "But the misfortune is, that too frequently after orchards are planted and fenced, they seldom have any more care bestowed upon them. Boughs are allowed to hang dangling to the ground; their heads are so loaded with wood as to be almost impervious to sun and air, and they are left to be exhausted with moss and injured by cattle, etc.
* * * "

"The feelings of a lover of improvement can scarcely be expressed on observing the almost universal inattention paid to the greater number of our orchards, and that people who go to considerable expense in planting and establishing them afterwards leave them to the rude hand of nature; as if the art and ingenuity of man availed nothing, or that they merited no further care!"

Is it fair to say that the average orchard of today is a more or less neglected orchard? If so, then perhaps there is a grain of comfort in thus being assured that the average orchard of our time is at least no worse in respect to the general condition in which it is maintained than was "the greater number" of the orchards 100 years ago.

Varieties Propagated

A numeral inventory of the apple varieties that have entered into American pomology shows some interesting facts. Such an inventory is made possible through a bulletin in the Bureau of Plant Industry series issued several years ago by the Department of Agriculture, entitled: "Nomenclature of the Apple: A Catalogue of the Known Varieties Referred to in American Publications from 1804 to 1904." This catalogue, as the name implies, contains a list of all the variety names, both accredited names and synonyms, that have been published in American works during the century 1804

* American Gardener's Calendar by Bernard M'Mahon, 1806.

to 1904. These works include the standard pomological books, horticultural magazines and papers, experiment station bulletins, nurserymen's catalogues, etc.

This catalogue shows that in the 100 years in question approximately 14,800 varietal names of apples have been published. Of this number about 6,700 are accredited names and refer to distinct varieties. The remaining 8,100 names are synonyms; that is, of the published names, there is an average of more than two names for every distinct variety. But as there are a number of varieties that have about 40 different synonyms, it follows that the distribution of synonyms is not on a very equitable basis.

The number of varietal names mentioned, 14,800, does not include the crab apples. If these are added, the number will be increased by about 600, making 15,400. Of these 600 names of crabs about 375 are accredited names, representing distinct varieties, while 225 names are synonyms.

Of course a very considerable proportion of the 6,700 distinct varieties of apples (not including crabs) that have entered in American pomology during this 100-year period have long since dropped out of cultivation and are now entirely unknown except by name.

The number of important varieties now commonly grown is suggested by the last revision of the American Pomological Society's "recommended lists" of varieties for cultivation, in the various pomological regions of the United States and Canada. This revision was first published as Bulletin No. 151 of the Bureau of Plant Industry and later included in the Proceedings of the American Pomological Society for 1909. The "recommended list" of apples comprises only 319 names—a relatively small number when compared

with the figures above mentioned. These last figures mean, if I interpret them correctly, that but slightly more than 300 varieties of apples include all or nearly all of those that are of real importance (except local sorts that are known only in restricted areas) in the American apple industry of today. In fact, it is probable that many of these varieties could be eliminated to the benefit of the industry. If we should include the crabs that are in the last "recommended list" of the American Pomological Society, we should need to add 32 names to the 319 varieties above mentioned.

Another comparison of varieties made on quite a different basis is also instructive in showing the trend in recent years. In 1892, Professor L. H. Bailey made an inventory of the apple varieties that were offered for sale that year by 95 different American nurserymen. This inventory* shows that in these catalogues there were listed 878 varietal names, including crab apples. The nurseries represented were located in about 40 different states and in one or more of the Canadian provinces. They were therefore widely distributed.

I have recently examined the apple lists in 100 catalogues of nurserymen in the United States that came to my office in 1910. These catalogues were from 32 different states. They are therefore representative as to distribution; I think they are also representative in every respect though the number includes a goodly proportion of the largest and most important catalogues that are issued. I find that in these 100 catalogues there are 472 varieties of apples offered for sale and 59 varieties of crabs, making a total of 531 varieties of apples altogether.

* (A revision of this list for elimination of synonyms reduces it to about 735 varietal names and about 40 names of crab apples.—Ed.)

Statistical Summary of Apple Varieties

Approximate number varietal names of apples in American publications 1804-1904	6,700
Approximate number synonyms, same sources.....	8,100
Approximate number crab apple names, same sources.....	375
Approximate number crab apple synonyms, same sources.....	225
<hr/>	<hr/>
Total number apple and crab apple varietal names.....	15,400

Number of varietal names of apples in last revision of American Pomological Society's "recommended list".....	319
Number of crab apple names, same source.....	32
<hr/>	
Total number in American Pomological Society lists	351
Number of varietal names of apples and crabs published in 1892 in 95 catalogues	878
Approximate number of distinct varieties of apples included in same catalogues	735
Approximate number crab varieties offered in same catalogues	40
<hr/>	
Total	775
Number of varieties of apples offered for sale in 1910 in 100 catalogues..	472
Number of crab apple varieties in same catalogues . . .	59
<hr/>	
Total	531

It is interesting to note here, contrasting the results secured from an examination of 95 catalogues in 1892 and 100 catalogues in 1910, that there was a smaller number of varieties offered for sale in the 1910 collection than there was in the collection of 1892 by about 263. Including the crabs the difference was 244 as more crabs were offered in 1891 than there were in 1892.

We can name about ten varieties of apples which comprise probably 75 to 90 per cent of the apples that enter into commerce. Such a variety list might comprise the Baldwin, Ben Davis, Jonathan, Northern Spy, Rhode Island Greening, Roxbury, Tompkins King, Yellow Newtown and York Imperial. These varieties are at least among the more important commercial sorts. And what of their history? Baldwin has been fruiting since the middle of the eighteenth century; Ben Davis doubtless began to be propagated a hundred years ago; Jonathan was shown on an exhibit table in 1829. Northern Spy has tickled the palate of the consumer for more than a hundred years; Rhode Island Greening was recommended for its long keeping qualities in 1806; scions of Roxbury were being grafted as long ago as 1650; Tompkins King had made something of a history for itself as far back as 1806. No one knows whence came the Winesap but it was described in 1817. Benjamin Franklin received specimens of Yellow Newtown (Albemarle Pippin) in London in 1759, while York Imperial has been prop-

agated commercially for about 80 years. What a history! There are comparatively few men who are growing apples in the United States today who haven't been born since the most recent of this galaxy of varieties originated. And yet these are the sorts which are very largely making commercial apple growing what it is at the present time.

Of course there are other important sorts that are recent candidates for favor, such as Stayman Winesap, but it is now 45 years since Dr. Stayman planted the seed from which it came; and Arkansas, better known as Mammoth Black Twig, but the original tree of this variety is probably 75 or 80 years old; and a Virginia variety now bidding for favor—Lowry, or Mosby's Best or Dixie, as it is variously called; but the original of this variety first attracted attention many years ago; and Delicious—this at first thought impresses us as a distinctly "new" apple as it was commercially introduced only about six years ago. Yet as a young tree probably five or six years old, it began to attract attention locally about 30 years ago.

These varieties forever link the past with the present in fruit growing, even reaching over in prospect, far into the future. They forcibly illustrate how an apple variety must be old in point of years before it can have an important place in the apple industry.

Development of Spraying

Turning now to another phase of the question, a few statements will point out the course of development in the spraying of orchards for insect pests and fungus

* Bureau of Plant Industry, Bulletin 151, U. S. Department of Agriculture; also Proceedings American Pomological Society, 1909.

diseases. This operation has developed within memory of the present generation, yet I doubt if the full significance of the rapidity with which spraying has come to be a universal practice, and an absolutely essential one, occurs to very many minds.

What is probably the first reference to the spraying of an apple orchard made in a horticultural meeting is recorded in the proceedings of the Western New York Horticultural Society for 1879. The account refers to a fruit grower in Western New York having been troubled the season before with canker worms. The report reads: "He procured a force pump and sprinkled the trees with water containing paris green. This not only entirely rid them of the canker worms, but to his surprise those apples which grew in that part of his orchard (the part that was 'sprinkled') were entirely free from codling moth worms. * * * " The one who gave this account, writing later of his experience in presenting the facts before the horticultural society meeting, says: "I * * * shall never forget this (the presentation of the matter) because of the way in which I was jumped upon as a crank."*

From this beginning the practice of spraying fruit trees for insects, especially codling moth, began to receive some slight attention from experimenters.

Slightly earlier recommendations than those of 1879 above mentioned were apparently made by the entomologist of the United States Department of Agriculture, but the New York State Experiment Station was the first station to publish a report on the use of poisons (paris green in this case) for the control of the codling moth. This occurred in the Annual Report for 1885 of the station mentioned above.

Spraying to control fungus diseases has developed apace with the control of insect pests, though in this country it did not receive serious attention until some time after spraying for insects had become more or less common.

Spraying for fungus diseases may be

said to have begun with the accidental discovery in 1882 of the preparation which later came to be known as Bordeaux mixture. This occurred in connection with the control of grape diseases in a vineyard in France.

It was apparently not till 1885 that Bordeaux mixture was used for the control of other diseases than those of grapes. It was about this time, or perhaps in 1884, that the control of diseases by liquid sprays first began to receive attention in this country. It was in the same year (1885) that the first formula for making Bordeaux was published in this country. This appeared in a report from the United States Department of Agriculture. In this same report appeared what is probably the first published suggestion that apple scab might possibly be controlled or at least checked by the application of some fungicide.

The formula for making Bordeaux mixture was widely copied by the agricultural press and in other publications, though spraying did not appear to "take" with anything like the favor that might naturally be supposed in view of its promising possibilities. The "experimental age" in American agriculture had not then arrived! The annual report of the then Section of Vegetable Pathology of the United States Department of Agriculture for 1887 appears to contain the first definite recommendation for the control of apple scab by the use of Bordeaux mixture. It was this same year, I believe, that Congress authorized federal aid in the establishment of an agricultural experiment station in each state in the Union. Spraying for the control of insects and fungus diseases at once became a subject of much experimentation at many of these stations which were located in important fruit producing states.

The rest of the story about spraying is quickly told. There was much to learn about this operation, however, and its acceptance as an essential factor in fruit growing was very gradual. The decade from 1890 to 1900 may be referred to as the "test period" of the operation and the period during which the fact of spraying as an important orchard practice was be-

* Spraying of Plants by E. G. Lodeman, p. 63.

ing accepted among fruit growers. This decade, too, was one in which fruit growing was greatly extended as the following figures taken from the Eleventh and Twelfth United States Census Reports will show.

Number of Apple and Peach Trees of Bearing Age in United States

Year	Apple	Increase	Decrease	Peach	Increase	Decrease
1890	120,152,795			53,885,597		
*1900	201,794,764	68%		99,919,428	85.4%	
**1910	151,323,000		33.4%	94,507,000		5.7%

* Since this article was written returns from the Thirteenth Census have been published showing a falling off in the number of trees of bearing age during the decade from 1900 to 1910 registering a loss in apples of 33.4 per cent and of peaches of 5.7 per cent from the figures of 1900.

** The number of bearing apple trees reported in 1910 is 151,323,000 and of peaches 94,507,000. When the 20 year period is taken into consideration there was an increase in 1910 of 78.9 per cent in apples over 1890 and an increase of 57 per cent in peaches for the same period.

It will thus be seen that during the decade from 1890 to 1900 there was an increase of 68 per cent in the number of bearing apple trees and 85.4 per cent in the number of bearing peach trees in the country.

It is hardly possible to refer to such a large increase in the producing capacity of orchard trees without at the same time suggesting that perennial question. "Is there danger of over-production?"

There is no denying on theoretical grounds that such a danger does exist, but the probability is very remote.

This fear of over-production is not modern though it is very up-to-date in the matter of its recurrence. It was said a half century ago that in 10 years' time apples would not be worth picking and there is said to be a record of a man in Western New York who cut down his orchard because of his fears in this respect. Today, so far as any actual experience goes, we are apparently no nearer the point of over-production in apples than was the case 25 and 50 years ago.

I have recently had before me the annual commercial estimates of apple production for a consecutive period of 17 years. The annual average of the estimates for this period is 41,134,000 barrels. The average for the past 10 years, including the crop of 1910, is 32,572,000 barrels and for the past five years the average is only 27,966,000 barrels.

It is evident that for one cause or another the production has been falling off on the basis of the several periods men-

tioned, even in spite of the great extension in the planting of apple orchards.

No doubt this drop in production is largely accounted for by the fact that for quite a long period of years conditions have been unfavorable for the production of fruit in large and import fruit growing regions. And when we think of it, is it not a fact that the year is a very exceptional one in which all fruit regions produce a full or normal crop of fruit?

Such a year so far as apple production was concerned apparently prevailed in 1896, when the largest estimated apple crop in the history of the country was produced, amounting to more than 69,000,000 barrels, according to the commercial estimates.

Another very interesting feature follows in natural sequence. The development of mechanical cold storage of fruits has been almost contemporaneous with the development of spraying and the great expansion of orchard planting. In fact, cold storage would amount to but little so far as apples are concerned if it were not for spraying, because there would be but very few apples worth storing if it were not for the use of insecticides and fungicides.

It was about the year 1890 that the first mechanical cold storage plant was used for storing apples. The development was rapid, once its importance was realized, but by 1896, the year of the big crop, the capacity of all such plants combined was relatively insignificant compared with the capacity at the present

APPLE TREES IN THE YAKIMA VALLEY

Plantings of Members of Yakima Valley Fruit Growers' Association

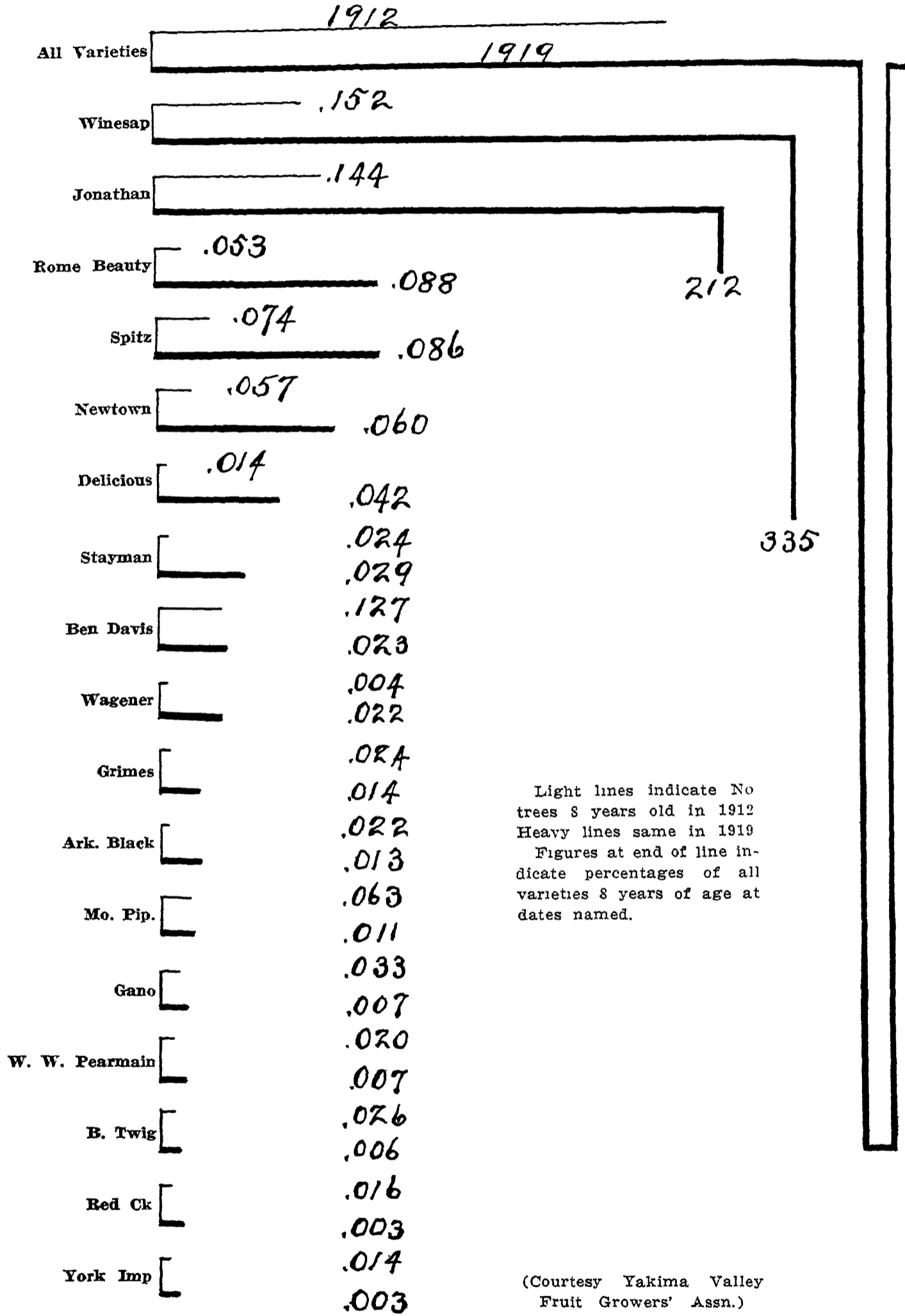

Light lines indicate No trees 8 years old in 1912
 Heavy lines same in 1919
 Figures at end of line indicate percentages of all varieties 8 years of age at dates named.

(Courtesy Yakima Valley Fruit Growers' Assn.)

time The significance of this fact is of the greatest importance. A 69,000,000-barrel crop of apples now, with the present storage capacity, would be a very different matter from the "over-production standpoint" that it was when cold storage was in its infancy.

Then, too, transportation facilities are constantly being extended and improved. This makes it possible to reach new markets. And as a matter of fact, very many domestic markets are now well supplied with native-grown fruit which ten or fifteen years ago had never had a consignment of fruit shipped to them. Consumers in vast numbers have been forming the fruit-eating habit, and habit once formed is hard to break if the means of continuing it can be made available.

In addition to an increasing fruit-consuming people at home, the export markets are an important factor in this matter of over-production, though their importance is because they serve as sort of a "safety valve" for market conditions. The quantity of apples exported in any one season in relation to the quantity produced in any ordinary year is so small that the influence of the export trade can hardly be due to the number of barrels shipped abroad.

Up to and including the year 1908, the million-barrel export trade was reached only twice prior to 1903. The first time was in 1881, when 1,117,000 barrels were sent abroad. The second time was in 1897, when 1,500,000 barrels were exported. From 1903 to 1908, inclusive, more than a million barrels were exported each year, the maximum quantity on record being in 1904, when the export trade exceeded 2,000,000 barrels. A million barrels of apples shipped abroad in any season out of a crop of 30,000,000 to 40,000,000 produced is only a very small part of the crop. Yet with the export markets open even for quantities that are small in comparison with the totals, the pressure at home may be greatly relieved.

In this same line of argument we should not forget our constantly and rapidly increasing population. A million and a quarter of immigrants coming to America every year will consume some of our

surplus apples if we only get them to the markets and within their reach. This increase amounted to 21 per cent during the decade 1900 to 1910. The people who make up this increase are helping to make a market for some of the fruit produced on the 68 per cent increase in the number of bearing apple trees from 1890 to 1900.

H. P. GOULD

Fifteenth Annual Session Vermont Horticultural Society.

APPLE ORCHARD

Selection of the Site

In selecting the site on which to plant an apple orchard, several things should be kept in mind. These various requisites may be discussed under the general heads of Soil, Climate and Market conditions. By soil conditions we mean all those factors which affect balance of ration, physical condition, drainage, fertility, etc., By climatic conditions is meant those factors which have to do with temperature, such as elevation; proximity to large bodies of water, air drainage; exposure to sun; prevailing winds; soil erosion; frost conditions, etc.

Soil Depth

The first and most important soil condition is depth. Apple and pear trees live longer and grow to be larger than peach, plum and most other classes of fruit trees. They will, therefore, need a root system large enough to support the large trunks and tops which they will have when they come to be old.

In Southern New Mexico there are apple trees large and healthy, but the fruit is not of good quality, which were planted by the Spanish missionaries 300 years ago. There is an apple tree at Vancouver, Wash. (see Fig. 1, *History of Apple*), which is said to be 87 years old, having been grown from seed planted about the year 1825 or '26. There is a pear tree near Bloomington, Ill., of the variety called the Suddith, which is more than 100 years old, and has been used within the last few years largely for grafting purposes because of its tendency to long life.

These facts prove to us the importance of selecting a deep soil for apples and



Fig. 1 A Native Apple Tree and a Pioneer in the Early Days in Connecticut. At Least 150 Years of Age. Conn. Sta.

pears, a soil which will furnish sufficient nutriment to the tree for two or three generations. It suggests the importance, also, of sufficient moisture, for soil depth is of little value unless the sub-soil or under stratum contains sufficient water to hold plant-food in solution. Many orchards are being planted in places where they will grow fruit successfully for 20, 25 or 30 years, but not for a longer period, because a few feet below the surface there is a stratum of rock or of hardpan, or perhaps there is not sufficient seepage to moisten the soil a very great depth and the food substances in the soil are not available. Especially is this so in the arid and semi-arid regions where it is necessary to resort to irrigation to grow fruit successfully. Then, too, in these

irrigated sections there are many places where there is sub-irrigation and the soil is wet to a very great depth. This may be considered desirable if there is not too much water to injure the tender roots of the trees.

In West Virginia I have observed that in every case where the orchards were from 50 to 75 years old they have been situated where the soil was deep and where there was seepage enough to supply the root system with more moisture than generally falls on the surface; that when the orchards were planted on situations where there was no seepage, and where the rock came near the surface, the orchards were dead. In 1905 I visited a number of farms where 40 years before there were flourishing orchards, yet



Fig. 2. Trees Like This With a Constricted Trunk, Were Probably Top-grafted About 1850. Conn. Sta.

at the time of this visit there was not a fruit tree living which was there at the earlier date. Some attribute this to a cold freeze that occurred in 1890, some to lack of rain. The fact remains, however, that the orchards that were planted where there was sufficient seepage from the hill-sides and sufficient depth of soil, are still living and the trees are in a healthy condition.

On account of the importance of this subject the opinions of many observers are given, covering the conditions of various localities.

GRANVILLE LOWTHER

Soils for Apples

Apples will grow on a great variety of soils, but most kinds do best on deep, rich clays or loams. Soils very rich in nitrogen should be avoided as they will produce too much wood growth at the expense of fruit. Very few soils are too rich for apples, however. Many farmers plant their fruit trees on the poorest and roughest pieces of land on the farm, because such soil will not produce any other

crop profitably. If the trees do not produce good fruit in a few years, without any attention, the orchard is abandoned and the farmer says fruit growing is a failure. Does he expect this of other crops and has he a right to expect it of apples? Give apple trees the care and attention that other crops get and they will respond by producing profitable crops of fruit. It is a mistake to expect trees to grow well on poor soil, for food is just as essential to tree growth as to the growth of cotton or corn. It requires a large quantity of food to produce a crop of trees and even a greater quantity to produce the fruit.

H. C. THOMPSON,
Agricultural College, Miss.

SOIL ADAPTATIONS TO VARIETIES OF APPLES

It is believed that different varieties have adaptations to different soils, which adaptations, if known, would guide the orchardist in the selection of a site for an orchard, or the selection of varieties suited to any particular soil, which he may possess.

* H. J. Wilder has treated this subject extensively, and a summary of his conclusions is given.

Baldwin Soils

If soils are thought of as grading from heavy to light, corresponding to the range from clay to sand, then soils grading from medium to semi-light fulfil best the requirements of the Baldwin. The ideal is to be sought in a fine sandy loam, or light mellow loam, underlaid by plastic light clay loam or heavy silt loam. The surface soil should be of a dark brown color, due to the presence of decaying organic matter. There is much of this soil in the Appalachian region, which from Canada to Southern Pennsylvania is adapted to the growing of Baldwins.

Rhode Island Greening Soils

For the Rhode Island Greening, a surface soil of heavy silty loam or light silty clay loam, underlaid by silty clay loam, excels. Such a soil will retain sufficient

* H. J. Wilder, Pennsylvania State College, 1911 Report.

moisture to be classed as a moist soil, yet it is not so heavy as to be ill-drained if surface drainage is not sufficient. The soil should be moderately rich in organic matter, decidedly more so than for the Baldwin. Such soil conditions maintain a long seasonal growth under uniform conditions of moisture, and yet produce a firm, crisp texture, the remarkable juiciness and high flavor for which this variety is noted when at its best.

Hubbardston Soils

The Hubbardston requires a light sandy soil. The lightest soil on which the Baldwin will succeed is about the heaviest required for the Hubbardston. Perhaps no apple will utilize a more sandy soil than this variety. This does not mean that it will succeed on poor light sands; for in such a soil, the apple will not attain sufficient size to be of value, nor is the tree vigorous enough. But the soil should always be very mellow. A rich fine sandy loam to at least the depth of a foot is preferable and the subsoil may well be of the same texture.

Northern Spy Soils

This variety is one of the most exacting in soil requirements. To obtain a good quality of fruit, fine texture, juiciness, and high flavor, the soil must be moderately heavy and for the first two qualities alone, the Rhode Island Greening soils would be admirably adapted. However, the fact that the Northern Spy is a red apple makes it imperative that the color be well developed and the skin free from the greasy tendency. This necessitates a fine adjustment of soil conditions. The habit of tree growth also is such as to require attention. Its tendency to grow upright seems to be accentuated on too clayey soils, if well enriched, and such soils tend to produce wood growth faster than the tree is able to mature. On the other hand, sandy soils, while producing good color and clear skins fail to bring fruit satisfactory in quality in respect to texture and flavor. The keeping quality too is inferior to that of the Spy grown on heavier soils in the same district. Hence the soil requirements of this variety are very exact-

ing, and are best supplied apparently by a medium loam, underlaid by a heavy loam, or light clay loam.

Tompkins King Soils

This tree with its straggling tendency of growth does not develop well on sandy soils. Light mellow loam, the sand content thereof being medium rather than fine, thus constituting an open textured loam, rather than a fine loam, is better. The subsoil should be either the same texture or heavier, in no case heavier than the light plastic clay loam. Subsoils inclining to stiffness in character should be carefully avoided.

Fall Pippin Soils

This variety will succeed on a wider range of soils than either the Northern Spy or the Tompkins King and soils adapted to these varieties are ideal for the Fall Pippin.

York Imperial Soils

The York Imperial is a leading commercial apple in Central Pennsylvania, Western Maryland, Northern Virginia and West Virginia. It is adapted to the limestone soils of this region, the Piedmont Plateau, and the ridges. The "Apple Pie Ridge" soils of West Virginia are also well adapted to the growth of this variety. This soil is a shale or soap stone base, formed of disintegrated lime stone and other mixtures. The Porter loam is also good soil for this fruit.

Grimes Golden

The Grimes is so similar to the Rhode Island Greening in soil adaptation that a separate description of soil best adapted to this variety will not be given. Yet it is not adapted to the same latitudes as the Greening. It will succeed best on a Greening soil too far south for the Greening to be a good winter apple. Plant the Grimes where the Greening tends to become a fall apple.

Rome Beauty Soils

In West Virginia where it is the leading commercial variety it gives excellent results on fine sandy loams and mellow loams of the Westmoreland and DeKalb series. In Southern Pennsylvania it does well and as far south as Alabama.

Stayman Winesap Soils

This variety seems to succeed well on loams and heavy, fine sandy loams with subsoils of loam or light clay loam. It does well in parts of Pennsylvania, but does not do well on the Porter's clay loam of Porter's clay of Virginia, where the Albemarle Pippin succeeds so admirably.

Wagener Soils

The tree is weak in growth, hence a soil that is deep, strong, mellow and loamy, should be selected. Stiff subsoils are especially objectionable.

Jonathan Soils

The tree is weak in growth and should be planted on a rich deep, mellow soil.

Ben Davis and Gano Soils

These varieties show less effect from variation in the soils upon which they grow than any other varieties observed. There are differences to be noted in the quality of the fruit on account of the soil and climate, yet it will stand more neglect than any other variety and still bear fruit. From Canada to Alabama these apples have numerous advocates. It seems to be especially adapted to the Ozark region, although in the Appalachian region growers believe they grow a finer quality of Ben Davis than in the Ozarks.

Yellow Newtown Albemarle Pippin Soils

The Yellow Newtown has always been regarded as exacting in soil requirements and climatic environments. Great stress has been laid on this point in Virginia, where it has received the local name of Albemarle Pippin. An ideal soil for this variety in Virginia consists of dark brown, heavy, mellow loam, to a depth of twelve inches, which grows gradually heavier to twenty-four inches, where it becomes a clay loam. This clay loam, however, is not stiff. Heavier soils are also adapted to this variety, if there is sufficient vegetable matter to render them friable. This is very noticeable with Porter's clay. Such soils, rich in plant food and retentive of moisture, furnish ideal conditions for this variety, which requires a luxuriant growth of tree to produce the crisp grain, and delicate flavor of fruit, as well as profitable yield.

So well did the Yellow Newtown thrive in the protected coves of the Porter's series in Virginia, where the leaves and vegetable debris had collected for so long that the surface material was black to a general depth of several inches and to a depth of several feet in particular cases, that it was only natural in the course of time for the idea to prevail that a great accumulation of organic matter in the soil was a preliminary essential for the success of this variety. But later investigations have shown that areas of Porter's loam and Porter's clay, not rich in vegetable matter have produced good results, and the habit of growing leguminous crops and the application of stable manure, has proven to be as effective as the original black soil. A good Rhode Island Greening soil is also well adapted to Newtowns.

Winesap Soils

The Winesap is a standard variety in Virginia and the Southern Appalachians—an apple of good quality that responds readily to favorable conditions of soil and treatment and also brings surprisingly good returns under neglect. The soil need not be as rich as for the Yellow Newtown because the presence of too much organic matter detracts from the color, yet the tendency of this variety to produce fruit under size makes desirable a soil as rich as may be without affecting the color. The Porter's loam produces apples of this variety of very fine quality. In the Valley of Virginia the Haggertown loam, on the Piedmont Plain the Cecil loam, and the limestone soils, are now producing good Winesaps. In the southern end of the Appalachians in Northern Alabama, the Clarksville loam is well adapted to this variety.

SELECTING THE LAND

In buying land the fruit grower should remember that he is buying its fertility, or its power to produce crops. He is buying not only crude earth, but all the forces above the soil as well as in it, that are needed to transform the crude elements into fruit. He should consider, therefore: First, the atmospheric conditions (elevation, exposure, etc.); and, sec-

ond, the conditions pertaining to the soil (its supply of available plant food, its physical condition, its depth, its drainage facilities and its general adaptability to apple growing). These matters should be considered, also, in respect to the adaptability of any particular field to the purpose intended.

In Connecticut the fruit grower or prospective fruit grower may choose between the improved land that may often be purchased for from \$40 to \$60 per acre, and the rough unimproved land at from \$5 to \$40 per acre. The higher priced land is often cheaper in the end, for the work of clearing in most cases is an expensive and uncertain undertaking. The rough "sprout" land that is being used by some of the prominent fruit growers of the state has proved to be not only very difficult to subdue, but very costly to manage for a number of years. The extra expense in clearing and in subsequent tillage of such land may often greatly exceed the original saving in buying the lower-priced land. Inquiry from those who have had most experience reveals the fact that it is impossible to set any definite figure as to the probable cost of preparing rough land for fruit growing.*

Subsoil

The ideal soil for an apple orchard is probably a heavy sandy or gravelly loam with a gravelly subsoil. The character of the subsoil is probably of greater importance than the surface soil. A gravelly subsoil insures better drainage and this is of the first importance, for an apple tree must have air around its roots as well as among its branches. The apple will thrive well on the lighter soils, but such soils require more careful treatment to maintain the necessary supply of humus and plant food. Some careful growers prefer a sandy loam for apples, for they believe that it produces fruit of better color. While some soils are more suitable than others, almost any soil, if properly treated, will produce apples successfully.

C. D. JARVIS,
Storrs, Conn.

* See Storrs' Bulletin 61, p. 73, 1910. "Cost of Clearing Rough Land."

Clay Loam

Three chief factors enter into the selection of the site for an orchard: Soil, elevation and exposure. Of these the soil is most important for even though the elevation and exposure be perfect, if the soil is unfavorable, the orchard will be a failure.

Clay loam soil is best for apple growing. In the past the tendency has been to select rather heavy clay loam or clay soils for apple culture. Less heavy clay loams and even soils tending towards a gravelly nature seem to give better results in Wisconsin. Heavy clays are much more difficult to handle, have a tendency to carry the wood growth too late into the summer, and do not give as good color to the fruit as do the somewhat lighter soils. Both late growth and low color are objectionable, and for these reasons heavy clays should be avoided where more suitable soils are available. It is not to be understood that light or sandy soils are preferred for apple growing.

Depth and Subsoil

The depth of soil best suited for apple culture depends very largely upon the character of the subsoil. With a suitable subsoil very little surface soil is necessary for success. Good results are being obtained where there are but two or three feet of surface soil underlaid by a suitable subsoil.

Limestone Subsoil

Pervious limestone subsoil is preferred. This type of subsoil permits the roots to work deeply into it, producing trees with extensive root systems. The limestone also aids in the production of high color which is so essential in a good market fruit. It is at least partially due to this fact that the apples produced in the Door peninsula are so highly colored. A gravelly subsoil would be second choice in selecting an orchard site. Impervious subsoils are to be avoided, especially if they come close to the surface. Such a subsoil hinders deep rooting and not infrequently brings the water table so close to the surface that the root system is confined to a shallow layer just under the surface. An orchard planted on such a

soil is sure to be a failure unless the subsoil be broken up and the water table lowered by drainage.

J. G. MOORE,
Madison, Wis

Apples Thrive on Many Soils

Apple trees will thrive and do well on almost any soil which is well prepared, but the different kinds of soil may require different treatment and after care.

Loamy Soil

A loamy soil is naturally rich in plant food; hence it will need little, if any, manuring in its preparation. But it should be deeply stirred and thoroughly broken up by subsoiling. This loamy soil is what may be termed free soil, as it seldom becomes compacted, even by abusive treatment.

Clay Soil

A clay soil is the most difficult to prepare, and often requires manuring, as well as thorough plowing, reploting, and subsoiling. It should also be frequently stirred during the summer months, and especially as soon after each rainfall as is practicable, to prevent it from baking and becoming compacted. This becomes even more important in seasons of long droughts.

Sandy Soil

Sandy soils are generally lacking in the necessary plant food. They also have the objection of losing such fertilizers as may be added by the leaching effect of the rainfall.

Effects of Several Soils

The wood growth on loamy soils will be strong and vigorous, but may not be sufficiently mature to withstand the freezing of the more rigorous winters. Clay lands are not apt to produce such vigorous growth, and orchard trees on such lands will be hardier as to winterkilling than on most other soils. With a free subsoil underlying it, a loamy clay soil will probably yield the best results, especially if it be well prepared by thorough culture and subsoiling before planting the trees. Timber lands, or lands on which forests have formerly grown, if having the proper exposure and drainage, are preferable for

orchard sites. Such lands contain all the elements of *plant* food necessary to insure a good and sufficient wood growth and fruitfulness. Fruit grown on such lands will rank first class in size, quantity, and appearance

G. B. BRACKETT,
Washington, D. C

Loam

If the extremely light sandy soils and the very stiff clay and adobe soils are eliminated, apples will grow well upon the soils intermediate between the two, providing, of course, that such soils are free from excess of alkali and are put in good physical condition.

The best soils for commercial apple production are moist, well drained, deep rich loam, derived from limestone or granite or volcanic ash, in which is found a considerable quantity of decayed vegetable matter or humus. There is a difference in the adaptability of apples to different soils, as, for instance, the Yellow Bellflower thrives best upon a rather light soil, while the Yellow Newtown Pippin seems to grow best in heavier ground. The adaptability of apples to particular soils can be determined only by experiment and observation.

R. W. FISHER,
Bozeman, Mont.

Ohio Soils

Admitting the truth that apples are being successfully grown, in some parts of Ohio, on soil so poor that it would not produce ten bushels of corn per acre, it is at the same time true that in order to secure healthy, vigorous, well-grown trees, which will devote a long life to generous fruit-bearing, there must be in the soil those elements which constitute fertility and good physical character. These elements, of which there are three more important, are both mineral and vegetable. Potassium and phosphorus are of mineral origin, while nitrogen is derived from the growth, breaking down and decay of vegetation especially that class of plants belonging to the family of legumes—the clovers, peas, vetches, etc.

Abundant decayed and decaying vegetable matter, within or upon the surface of the soil, is very desirable aside from

the direct bearing it will have upon the nitrogen supply. A soil filled or covered with humus or vegetable fiber readily absorbs and retains a vastly greater amount of water than a soil depleted of its humus by frequent and injudicious cropping or cultivation. The humus also acts as an effective medium of insulation against extremes of cold and heat.

F. H. BALLOU,
Wooster, Ohio

Forest Soil in Idaho

Soils from which native forests have been cleared are best adapted to growing the apple. These are in good physical condition so that ample surface drainage and subdrainage are supplied; besides they have a plentiful supply of plant food which is essential to a healthy wood growth and a finely developed, well matured crop of fruit. It has been repeatedly noted that fruit from such soils reach the highest degree of perfection both from point of quality and color. However, soils which may be brought to a state similar to that found on old forest sites, may be regarded as being well adapted to the growth of the apple.

Medium clay loams adapt themselves admirably to the apple, and if these possess, or are made to possess, the following requisites, orchards may be planted upon them successfully. These important requisites are: Good water drainage, good texture and sufficient richness in plant food.

Where good natural drainage is not found, tile drainage should be provided, because apple trees will not endure 'wet feet.' The phrase, 'good texture,' means that a soil possessing this characteristic will work up loose and mellow without being hard and lumpy. Such soils are easily worked and hold plenty of moisture. Most of the good orchard sites in Idaho are sufficiently rich in plant food, so there is no direct need of applying plant food at the time of planting.

J. R. SHINN,
Moscow, Idaho.

North Carolina Soils

Where virgin soil from the forest cannot be obtained for orchard planting,

only rich land should be used. As an orchard will occupy the ground for many years, very thorough preparation should be given the soil before planting the trees. Never set trees on poor or dry land, for if they do start they are so stunted that it is next to impossible to ever get them to make a satisfactory orchard. Land kept in good tilth and used for cultivated crops can be expected to give reasonably good results in starting and growing orchard trees. Lands used for grain crops should be shunned for orchard work, as they are almost certain to be of the driest and poorest character. Old pasture lands are very poor for tree culture. They may be fairly rich from the droppings of the stock, but the humus in them is ruined by trampling and their mechanical texture is at its very worst. A good previous crop is a heavy growth of some kind of leguminous plant. This crop should be plowed down to furnish humus for the trees. It is more or less difficult and expensive to improve land after trees are planted; so it is best to spare no pains on previous preparation. Preparatory to setting the trees the soil should be deeply plowed. Clean surface cultivation should be given to conserve moisture. A liberal dressing of manure is always beneficial. The manure should never be put in the holes in which the trees are planted, but it should be incorporated in the soil by general cultivation.

Stumpy Land

It is by no means necessary that a virgin soil should be cleared of stumps and stones before planting the orchard trees. Unless a stump is actually in the place where a tree should be set, it is not necessary to go to the trouble and expense of having it removed. It is much cheaper to let stumps rot out gradually, and while they are doing so they are supplying humus to the growing fruit trees.

Stony Land

Stony land is not at all objectionable for commercial orcharding. On steep locations they help very greatly to hold the rich soil from being washed away. It is probably for this very reason that in

many mountain orchards the stony soils produce the best trees. Loose stones may be placed to form shelf terraces between each two rows of trees. Unless the soil is very thin, stones may be considered as a benefit rather than otherwise, because of the value they have to the land in assisting drainage and in protecting soil moisture. It is noticeable that fruit trees near rock piles or stone fences suffer little from drought.

Clay Land

Apple trees will grow on a great variety of soils, but they feel most at home and give their best results on deep, rich clays and loams. Why they prefer these soils it is impossible to say, but apple trees seem to be suited to clays just as cacti are to desert sands. The early or summer apples do well on light or sandy soils because they ripen their crop before the hot season, when moisture is scarcest. Late fall or winter varieties, which have to develop their fruit in the hot summer, when moisture is hardest to get, must have a soil that is retentive of moisture. Muck soils are rich and contain abundant moisture, but they produce large, rank-growing trees with tender terminals that produce poor fruit.

Rich Soil

Apple soils should be rich and they should not be called upon to produce anything but apples. It takes a great deal of fertility in the land to produce the wood of the trees on an acre of orchard. The fertility that produces the fruit is over and above that required to grow the trees. There are few crops so exhaustive on land as a crop of nursery stock, and no tillers of the soil know so well how to fertilize the soil as do nurserymen. If trees continued to grow in the orchard with the vigor they are made to do in the nursery there would be a thousand-fold greater returns from the orchard than there are today. From my experience and observation in horticulture, I think it safe to say that 75 per cent of all the trees that leave nurseries die of starvation before they come to usefulness. Soil poverty destroys more trees than all the pests and plagues put to-

gether. A soil cropped to death with corn or cotton or tramped hard by the feet of stock is a certain burying ground for the tender and well-favored tree from the fertile soil of a nursery. The reason timber trees grow so well in their native forests is that the fertile, spongy mould of the forest floor affords an ideal home for the little seedlings till they get big enough to fend for themselves. Soil for orchards should be as nearly as possible like nature's model forest soil. Indeed, the best soils for fruit trees are those just vacated by the forest primeval and occupied by the orchard before they can be pre-empted by any other agricultural tenant. Mountain coves are ideal for orchards.

W. N. HUTT,
Raleigh, N. C.

New York Soils

The apple will grow in a variety of soils. Even on a poor soil it will struggle to maintain its life and to reproduce through its fruit, as reproduction is the real object of all life, animal and vegetable. There are, however, certain kinds of soils that are much better adapted to the development of apple trees than others. A soil that contains a certain amount of clay in its composition is excellent. Trees will grow in a stiff clay, but such soil is often over-saturated with water and trees will not do their best with too much water about their roots. Air, which is necessary for the roots of trees and for all plants, is frequently shut out by the water in clay soil. Such soil should be well underdrained before trees are planted in it.

Clay and Sand

A soil that is made up of a mixture of clay and sand, and is known as a clay loam, is excellent for apple trees.

Trees will grow in a sandy soil, but they will not grow so large, neither will they produce so much fruit. The trees and the fruit on sandy soil are more subject to insect attack, for insects thrive better in a dry soil than in one that holds water for a long time.

There are, however, variations in sandy soils that produce not only good

trees but an abundance of excellent and beautiful fruit.

The subsoil is an important factor in the planting of trees, and its quality and character should be understood. It is closer and more firm than the top soil, and retains moisture longer, but it may be made up of such fine particles of clay and with so little vegetable matter in it as to be impervious to water, and this constitutes what is known as hard pan, and if this lies up to within a foot of the top soil, trees will not thrive in it, neither will they produce much or good fruit.

Such formation near the surface prevents the water in the soil below from rising to supply the needs of vegetation, through long periods of drought. Where a hard pan formation may exist from six to ten feet below the surface, it is of great value, for there a certain moisture supply is assured through dry seasons, especially where frequent cultivation is given to the surface soil.

HON. GEO. T. POWELL,
President Agricultural Experts Association,
New York.

New Mexico Soils

In many of the old treatises on apple culture we find it stated that the apple prefers a heavy soil. The more recent authorities on the subject modify this statement by saying that it is quite cosmopolitan in its adaptability to soil. In New Mexico a heavy or an adobe soil, as found in some of the valley lands, is not so suitable for apple trees as a good, strong and deep loamy soil with a stratum of heavy clay underlying it. A heavy soil of one or two feet in depth underlaid by sand or gravel is not good for apple trees. On the other hand, a soil ranging from five to seven or more feet in depth of a good, strong, loamy character and underlaid by a heavy adobe stratum is an ideal location.

FABIAN GARCIA,
Santa Fe, N. M.

Upland Soil

Upland timber soil, particularly that known as "White Oak Soil," is well adapted for orcharding. Loess soil is good also, as the roots can penetrate it readily.

Black prairie soils are often very rich in nitrogen, which causes an excess of leaf and wood growth late in the season. This lessens the production of fruit buds and makes the tree more liable to winter injury.

A. T. ERWIN,
G. R. BLISS,
Ames, Iowa

Oregon Soils

Upon this very important phase of orchard-making, all authorities are practically agreed. From the old orchards, and especially the old trees of both Europe and America, the West and East, the same lessons are learned. With one accord these trees, though separated by leagues of land and water, proclaim the creed of the apple tree—complete air and water drainage, and a deep, loamy soil.

Speaking upon this topic about 200 years ago, Miller, an English authority, said:

A gentle hazel loam, which is easy to work and does not retain the wet, is the best. Although these trees will grow on very strong land they are seldom so thriving, nor is the fruit so well flavored as upon trees grown on a gentle soil. Dry, sandy, or gravelly soils are wholly unfit for the apple tree.

Delaville,* writing upon the subject of soils suitable to fruit culture in France, says:

A good soil for all fruit trees is composed of equal parts of sand, clay, and lime.

Baltet,** a popular French horticultural writer, in discussing the subject of soils desirable for the apple, remarks that:

A wheat soil is the soil for the apple tree when grown as a standard.

The importance of thorough drainage in connection with a good soil is emphasized by the same author in these words:

The fruit of the apple is largest in the humid valleys, but best flavored on the hills and dry table lands, the excess of humidity, as the need of free air, inducing canker and favoring the aphid.

* Cours Pratique D'Arboriculture Fruitiere, 1897.

** Traite de la Culture Fruitiere, 1900.

Nanot,¹¹⁴ in his treatise upon the cider apple, thus speaks of the soil as bearing upon this fruit:

The apple is not very particular as to the nature of the soil; it neither dislikes very clayey, very limey, nor very sandy soils, but the best flavored and longest keeping fruits come from trees grown on clay loam.

Dr. L. H. Bailey,¹⁴¹ speaking of apple growing in the Eastern United States, says:

As a rule, rather light or loamy soils, with deep and porous subsoils, are best adapted to apple growing. Natural drainage is imperative. Apple trees are impatient of wet feet

At a meeting of the Oregon State Horticultural Society, held in Newberg in 1901, E. L. Smith made the following statements while speaking briefly of the apple:

Apples grown on sandy soil will weigh much less per bushel than those grown on clay or clayey soils, other conditions being equal. Apples to be long keepers must be grown on soil having some clay.

In reply to a question relative to this point, Col. G. B. Brackett, the pomologist of the U. S. Department of Agriculture, writes (1904): "I know of no experiments along this line, but I am inclined to think that apples grown upon clay loam, other conditions being equal, would be somewhat heavier than those grown upon light, sandy soil. I know that apples that are grown on heavy clay soil are apt to keep better than those grown upon light, sandy, porous soil. Of course, keeping qualities depend somewhat upon latitude, and also upon the elevation at which they are grown."

From somewhat extended general observations in the apple orchards of Western Oregon during the past decade or more, I am convinced that much of our soil is admirably suited to the apple tree. The land upon which the Douglas fir thrives, when not too steep and rocky, is usually well adapted to the culture of this fruit. The alluvial soils of the minor

valleys when of a depth of eight to twelve feet or more produce thrifty, vigorous, long-lived trees. Some of the best old orchards in the state are located upon the gentle rolling lower hill lands of Yamhill county, while some of the cleanest and thriftiest of the younger generation orchards are to be found on the red hill lands of Polk and Marion counties. In the selection of a site on the higher elevations, or even upon the lower hill lands, care must be exercised to the end that shallow soils may be avoided. Streaks, patches, or larger areas of these lands are occasionally underlaid at a depth of a few feet by strata of impervious rock. Such sites are wholly unfit for orchards. Only a close and thoughtful inspection of hill land tracts will enable one to avoid setting trees on soil too shallow for the successful growth of long-lived and fruitful trees.

Many excellent small orchards are to be found upon the river bottom lands in all parts of the Willamette valley. While these latter sites are well suited to the growth of the apple tree, it is probable that better returns horticulturally may be obtained by the cultivation upon such sites of the smaller fruits and the choicer vegetables, especially when nearby markets are reasonably good. The latter crops cannot be grown upon the higher lands with the same degree of success as attend their culture upon the river bottoms, while with the apple there is no apparent difference save, perhaps, in the degree of earliness with which the trees begin to bear profitable crops.

Generally speaking, orchards upon bottom lands will begin to bear from one to three years later than those upon the higher lands. There are well known instances in which trees planted upon river bottom land, as a result of an abundance of water, have extended their vegetative period three to four years beyond the normal period of the same varieties when grown upon correspondingly good upland sites. The economics of horticulture would appear to point toward the uplands as affording the more promising sites for the apple orchard, since the value of such lands will not increase as fast as that of

*** Le Culture du Pomme a Cidre, 1895.
**** Field Notes on Apple Culture, 1893

the more restricted tracts of suitable river bottom soils.

E. R. LAKE,

Oregon State Board Horticulture, 1911.

See also article on "ADAPTATION OF VARIETIES TO ENVIRONMENTS."

Volcanic Ash and Apple Culture

The question is often asked, "Why is the Pacific Northwest becoming so famous for the production of apples?" There are three general answers to that question. The first is that the latitude is in the great apple producing belt of the world. Even where the latitude would seem not to be far enough north the altitude of the hills and mountain ranges often compensates for the distance south, and gives cool nights, and a temperature favorable for the growing of the best fruits.

Second, in a large part of this country there is during the day a bright sunshine and at night a cool air, both of which tend to give color and flavor to the apple.

Third, the character of the volcanic ash soil, of which a large portion of this region is built, is favorable for the growth of the apple tree and its fruits.

The following are the principal soil elements necessary to the growth of the apple tree:

1. Nitrogen. 2. Salts of lime. 3. Salts of potash. 4. Salts of phosphorus. 5. Salts of iron.

In the arid regions the soil is rich in mineral substances, because the volcanic ash, rich in these elements, has never been leached by heavy rains. This soil may be improved by the addition of barnyard manure or the growing of cover crops like clover, alfalfa, or vetch, to supply humus and nitrogen. In the humid regions where the rains of centuries have leached the soil and where there is a large vegetable growth it is sometimes necessary to supply mineral fertilizers. However, the general character of the soil in the inland region is volcanic ash, rich in lime, potash, phosphorus and iron.

Further, there are numerous valleys, with good drainage systems that are protected from heavy winds by hills or mountain ranges, and in these valleys orchards can be successfully grown without dam-

age to the fruit from storms. In these valleys irrigation is successfully carried on and the melting snows in the mountains furnish abundant water.

In the bottoms the soil is sometimes a deposit of sand, gravel, and wash from the hill sides, favorable for the deep rooting of trees. On the uplands it is generally a fine ashy substance, into which the roots may penetrate to considerable depth. In places the wind has carried it for ages, and deposited it in coves, sheltered places, and behind the hills, so that it may be under such conditions, 50 to 100 feet deep. However, in such deposits the tendency is, under irrigation, for the soil to puddle and become impervious to the water, which prevents aeration, and the percolation of water to a depth sufficient for the root development of the large trees. In such a case the best remedy is the growing of alfalfa, with its strong root system, which penetrates below the puddled stratum, lets the water down, aerates and nitrogenizes the soil and opens up a new world of food for the roots of the trees. In some places there are strata of hard pan, which must be broken up with dynamite; but in general a volcanic ash region is a region most favorable for the growing of apples.

GRANVILLE LOWTHER

WEATHER CONDITIONS

The liability to frost is one of the things that must be kept in mind in selecting the most favorable site for an orchard. Reference is made in the article on frosts to the Thermal Belt where there is not likely to be injurious frosts during the seasons of blooming and fruiting. (See Frost.) In this connection we would say that there are three natural conditions that protect from frost. The first is elevation; the second, air currents; and the third is the modification of temperature by the warmer atmosphere from large bodies of water.

Elevation

By elevation, we do not mean the distance above the level of the sea, but relative distance above the surrounding country. For instance, if the general level of a particular portion of the country



Mosier Hills. Rolling Country Like This Is Excellent for Orchards.

is 1,000 feet above the sea, and just above that is a level 100 feet higher, the 1,100 foot elevation would be a situation that would furnish air drainage, because of the lower levels that surround it, and into which the cold air tends to settle. However, if a certain portion of the same country rose to an altitude of 1,200 feet and stretched out as a broad plateau in which there was a basin 100 feet deep, the land in the basin, though on the same level as the land at 1,100 foot elevation and 100 feet higher than the general level adjacent to it, would be in danger of frost because it was surrounded by higher lands which prevented air drainage.

Valleys

Valleys are not objectionable if they are so situated that the air currents are not obstructed. However, if there are sudden changes of direction so that the drift of the current would strike a hillside instead of continuing its course down the valley, the land in the valley would be considered to be located in a basin.

Water

It must always be borne in mind that

the temperature in cold weather, unless modified by breezes from large bodies of water, is cooler on the lower elevation than on the higher and therefore more likely to freeze. If a site is chosen with a view to protection from frost by the warmer temperature from large bodies of water, the direction of the prevailing winds should be considered, so that the warmer atmosphere will be carried across the site of the orchard. If the winds are strong, windbreaks may be necessary.

Slope

The question of a north or south slope is often discussed. This, like many other questions, must be determined by local conditions. If there is no danger of frost on either slope from that viewpoint the south slope is preferable because it gets more of the direct rays of the sun, the soil is warmer, the trees bloom and fruit a little earlier, and the fruit is more highly colored. In some sections, however, the early fruiting and the warm sunshine are objectionable. If there is danger of frost then the north slope is preferable, from that viewpoint, because the orchard will be a few days later in

blooming, and therefore less likely to be injured by frost. In regions where there is much freezing and thawing in winter, the soil of the southern slope is not generally so deep, because the melting snows of winter have washed much of it away, whereas on the northern slope the snows have not melted until the spring time and the soil is not disturbed. . This process in one year may seem to be of little consequence, may not even be visible in any considerable degree; but in a thousand years it makes a good deal of difference, even in some cases the difference of bare hillsides on the south and a deep soil on the north. However, it must be observed, that, other things being equal—that is, provided there is sufficient depth of soil on the south side—the farmers universally grow larger crops on that side of the hill than on the north.

Varieties Adapted

The larger varieties of apples may be grown on the higher levels as they tend to grow smaller in the rarer, cooler air. Those that tend to be rather too small for the best market conditions may be grown on the lower levels, as they will grow to be larger in the valleys.

Apples that ripen too early for the best markets would better be grown on a clay soil on the north slope of the higher elevations. Apples that do not ripen early enough may be grown in the warmer sandy soils or on the south slope of the lower levels.

GRANVILLE LOWTHER

Exposures

Exposure of Orchard

This much discussed question is not worthy the importance given it in many horticultural writings, as questions of soil drainage, irrigation facilities, tillage, spraying, pruning and fertilizing are much more potent factors in successful fruit growing.

North or Northwestern Slope

All other things being equal, a northern or northwestern slope may prove the best for commercial orchards. However, this is a question influenced largely by local conditions. The earliest fruits and veg-

etables are likely to be secured on a southern exposure because the rays of the sun strike such an exposure more directly. During very warm weather there is more danger on such slopes of injury from sun-scald. There is less danger on a northern exposure from frosts because on such slopes growth is often retarded a week or ten days in the spring until the frost period has passed. Sweet cherries and other fruit crops that are subject to injury from spring frosts are likely to produce the best results on a northern slope.

R. W. FISHER,
Bozeman, Mont

The most intelligent and experienced orchardists differ as to the best location and exposure of an orchard, some preferring a northern slope, others an eastern, and yet others recommend a southern or even a western slope as best. It is believed that the advantages preponderate in favor of a gentle eastern or northeastern slope, as orchards located on such sites suffer less in both soil and tree from the effects of heat and drought. An orchard with such an exposure will maintain its vigor and longevity better than if inclined to the west or southwest. This is especially true in states south of the New England group, where the summers are long, hot, and dry, and where it is probable that the greatest injury to trees results from these causes. But, as before stated, all farms do not afford these favorable sites, especially near the home, which is the most desirable location for the family orchard. Thus the planter will often be forced to forego such a location and take his chances where the natural conditions are not so favorable. If possible, the site should be elevated above its immediate surroundings, thus giving a free circulation of air, while such an elevation will also be of great aid in guarding against late spring frosts, so fatal to young fruit at the blooming season.

G. B. BRACKETT,
Washington, D. C.

New England

A northeastern or eastern exposure, which is commonly suggested, is less es-

sential with the apple than with less hardy fruit. Almost any exposure other than a northern or western one on a steep slope will serve admirably. More attention should be paid to good air drainage than to slope; hence an apple orchard should be raised somewhat above the adjoining land, at least on one side.

Due regard should be given to exposure to strong winds. Wind-swept hillsides or knolls should be avoided, or, if such are chosen, windbreaks should be planted at once on the sides from which blow the strongest winds. White cedar, Norway spruce, hemlock or white pine make the most effective hedges. The tree rows should be set far enough away from the hedge to insure them against injury from shading or from robbery of plant food.

WILLIAM STUART,
Burlington, Vt

Exposure is the direction of slope of the site. By a northern exposure is meant a site in which the general slope of the land is towards the north. On rolling sites it is impossible to have all the land slope in the same direction, but in such cases it is the general slope which is considered. *No one exposure is best under all conditions.* As a rule, in this state a northern or northeastern exposure is preferable. The trees are slower in coming into blossom in the spring than when the orchard has a southerly exposure, and therefore there is less danger from late spring frosts. Near large bodies of water best results are secured by having the exposure toward the water. In regions of high winds, much damage often results from fruit being blown off and from rapid evaporation of moisture. These injuries are reduced by choosing a site which has an exposure away from prevailing winds. Fortunately in most locations in Wisconsin this direction will be north or northeast, and thus coincides with the general exposure.

J. G. MOORE,
Madison, Wis.

Altitude

The proper location of a commercial apple orchard within the limits of Idaho is no small task as there are many prob-

lems involved. Above all things in selecting a location for a commercial orchard it is essential that a locality be chosen where the elevation permits proper maturing of the apple. In favored sections apples are now grown at an elevation of 6,000 feet, but it is rarely advisable to plant an orchard above 5,000 feet. The greater percentage of the profitable commercial orchards at the present time are in sections where the elevations are below 3,000 feet. Local markets and the family needs may be supplied with apples grown near the upper limits of elevation, but the general markets demand such varieties as are adapted to regions of lower altitudes.

J. R. SHINN,
Moscow, Idaho

An apple tree, in its soil and fertilizer requirements, differs little from a forest tree. The conditions of soil that will produce heavy timber will produce productive fruit trees. Forest trees grow naturally on mountain slopes because they find there a rich soil, abundant drainage and clear sunlight. The same conditions will produce large, productive, long-lived fruit trees. Where the natural forest is taken off the mountain slopes by the lumberman a forest of fruit trees can profitably succeed it. Indeed, no cultivated crop so well holds sloping lands from washing as do the strong roots of fruit trees. The common agricultural trouble known in the South as "washing of land" is only another name for uncontrolled drainage. Trees, since they are perennial in growth and have their roots in the soil at all seasons, are more useful than any other crop in protecting mountain lands from destructive erosion. Sloping soils which will wash must necessarily be well drained. This is the foremost reason why trees like sloping land and why mountain orchards give better results than those in similarly cool locations, but on flat lands with the water table too close to the surface.

W. N. HUTT,
Raleigh, N. C.

Thermal Fruit Belts

In mountain regions, where elevations are greatest, the maximum of exemption

from frosts is experienced. There are many places in our mountains known as thermal belts, which are said to be entirely free from frost. Whether or not this is claiming too much, it is certain that distinct lines can often be seen separating bright, fresh verdure above and blackened, frost-bitten foliage below. Similar lines of demarcation can be seen in spring between the early growth on the hillsides and the dormant buds of the valley below. In summer over the same area can be seen a distinct cloud line marking the height of the fog in the valley below, while above it on the hillside will be cloudless air bathed in sunlight. In the fall, when frosts have claimed all the tender vegetation of the valley, there will be seen longitudinal bands skirting the hillsides, showing for a month or six weeks all the freshness of summer. Though the exact borders of these thermal zones cannot be located with precision, their general position is fairly constant. Orchards planted on thermal belts are remarkably regular in fruit bearing. There are many orchards in the mountains where old settlers claim they have never seen a failure in a crop from frost. The reason for these peculiar phenomena is undoubtedly the draining of cold air from the hillsides and its stratification in the valleys below. There are other circumstances connected with thermal belts that have not yet been fully worked out. However, there is at present sufficient practical evidence of the value of thermal belts in frost protection. Fruit growers should not fail, where possible, to take advantage of them in orchard planting.

W. N. HUTT,
Raleigh, N. C.

Rolling Land North Slope

The best site for an orchard is gently rolling land with a north or northeast slope. Always avoid flat land or valleys for cold air, being heavier than warm air, settles to the lower places and frost is more likely to kill the blossoms in such locations. If planted on the south side of a hill the trees will be warmed by the sun in spring, and, being protected from the cold north winds, will

blossom early and may be killed by frosts. On the north slope the cold winds will keep them in a dormant condition longer or until danger of frost is past. Much of the land that is too hilly for profitable production of other crops will produce good crops of apples if given the proper care and attention.

H. C. THOMPSON,
Agricultural College, Miss

Air Drainage and Frost

In mountain regions, besides the draining of water from higher to lower levels, there is a similar drainage of air. This latter might seem to be of trifling importance in fruit growing, but it is in fact one of the most important considerations, for it tends greatly to avert frost. Freezes and frosts are undoubtedly the greatest hazard of the business of fruit growing. No disease or depredator destroys half so many hopes and dollars for the fruit grower as a few hours of frost. We are told that "the *frost* falleth alike on the just and on the unjust," but in seasons when the daily papers are heralding reports that an untimely frost has taken the entire fruit crop of the state some lucky fellow high up in his mountain coves, with not too many good works to his credit, has his entire crop saved as if by miracle. Frosts appear to strike in a very erratic manner; they are, however, like other phenomena of nature, subject to very definite laws. It is well known that as air becomes heated it ascends, and as it cools it becomes heavier and falls. On sloping ground air as it cools passes down from higher to lower levels. Other things being equal, low lands are more frosty than higher lands, because the cold and frosty air drains from the higher and settles into the lower levels. A corn field in the fall gives one of the best illustrations of the places most subject to frost and those also which are exempt. On the bottom lands the blades and stalks will almost invariably show where frost has bitten first. Up on the hillsides and higher elevations the corn will often be found growing fresh and green, while in the bottoms below not a green stalk can be seen. Where knolls occur in bottoms

they will often be seen to lift their green-clad sides out of the blighting frost-laden atmosphere of the surrounding valley. Air drainage is just as natural as water drainage, and for orchard locations is just as important a consideration.

The frostiest locations, and those therefore to be most avoided are valleys shut in on all sides. To the uninitiated these places would appear to be most admirably protected, but they are veritable frost pockets. On cold nights they receive the cold air from higher regions, and frosts and freezes in them are inevitable.

Once while traveling in the Rocky mountains I saw one of these small valleys shut in by hills, in which all the vegetation was nipped by frost. The surrounding hills on one side were somewhat lower than on the other sides. When the valley became full of cold air it flowed over the lowest side, just as water would have done. All around on the other sides of the valley the high frost mark could be seen, and it formed a line on a level with the top of the lowest hill where the frosty air had flowed over. Above this line the tenderest vegetation showed not the slightest injury. A valley with a large outlet will usually be reasonably safe from frost. The land about rivers which have a considerable fall will be drained of water and also of cold air. Lands contiguous to such streams can be counted on as being reasonably safe from frost. Experience with frost shows that mountain regions are much safer for fruit growing than the lands below them. A carefully planned and conducted experiment which I made two years ago in a hillside peach orchard confirms the results of general experience on this point. This orchard was carefully surveyed with a leveling instrument and the ground mapped out in contours. Contour lines connected all the trees at the same elevation. There was two feet difference in elevation between each two contour lines. Self-registering thermometers were placed on each contour line and readings were made on them three times a day throughout the entire winter and spring. The lower contour lines almost invariably registered lower temperatures than the higher ones.

There was usually from one-half to one degree of difference between each line and the one above it. Instruments placed along one contour line, thus all being at the same elevation, showed practically no difference in temperature. During the winter zero temperatures were recorded in this orchard. At pruning time in the spring it was found that the wood of the trees on the lowest contour had been badly frozen and was 'black-hearted.' The effect of the "black-hearting" lessened with higher contours, and on the highest one not a single affected tree could be found. The only fruit produced in the orchard was on the two highest contours. Higher land above this, which was not planted to orchard, would undoubtedly have been a safer location for peaches. The same season an estimate was made on the effect of winter freezing of peach buds on trees grown on comparatively level land. A measuring pole was placed in the trees and by means of a step-ladder the buds were examined and counted at different heights from the ground. An examination of 1,300 buds gave the following percentage of buds killed by frost:

Two feet from the ground	50%
Four feet from the ground	.30%
Eight feet from the ground	16%

These are only a few of hundreds of such examples that could be given to show the advantages of elevated locations for fruit growing.

W. N. HUTT,
Raleigh, N. C.

Elevation and Exposure

The best site for an orchard is one that is somewhat elevated above adjoining lands. Such a site not only gives better soil drainage, but what is more important, better air drainage. It is well known that the colder air being heavier settles to the lower levels. A difference of several degrees due to this fact is often observed in different sections of an orchard. This is, therefore, an important consideration in sections where hard winter freezes and late spring frosts are common. Moreover, on account of the clearer atmosphere and the relatively

longer periods of sunshine, fruit that has been grown on the higher elevations is likely to be of better quality and appearance. A southern slope offers relatively more sunlight, but there is a common notion that with such an exposure an orchard is more susceptible to injury from late spring frosts. While it is true that the buds of trees on a southern slope will start earlier than those on a northern slope, there is little danger from this source if proper attention is given to elevation. The most experienced apple growers favor an eastern or northeastern slope, but in most sections of New England the apple may be depended upon to do well on any slope. A western slope, however, is objectionable, unless the trees are protected from the strong prevailing winds. The use of a windbreak in such cases will prove valuable in the way of checking the evaporation from the soil and trees and of preventing the breaking of the branches and the falling of the fruit. A forest on the windward side of an orchard is often worth more as a windbreak than for any other purpose.

C. D. JARVIS,
Storrs, Conn.

Air Drainage

If possible, by all means select a site that is naturally well drained. It should be so drained that both an excess of water and cold air can readily escape to a lower level. While the apple very much dislikes a wet, soggy soil, it equally dislikes a site upon which cold air may stagnate. Cold air seeks the lowest levels. It frequently carries with it the frost waves that kill blossoms in the spring, or immature wood in the autumn. The force of this point is readily impressed upon the minds of all those who drive over the gently undulating sections of our valley after nightfall in the spring or early autumn months. Every hollow, especially if it be one without pronounced outlet to lower levels, fills up with cold air, and as one passes from the crest to the bottom and up the opposite side, the change from the cold air of the bottom to the warmer strata above is as distinctly marked as the passing from a warm room to the open air on a frosty morning. Such places,

hollows, or pockets, into which cold air may settle and remain with little or no motion, are death traps, not alone for the apple, but for fruit trees in general. Though the soils in such places may be good and deep and water drainage of the best, yet is the site deficient in one of the most important elemental features of a site—air drainage. It is as imperative to keep still cold air away from the tree's head as it is to keep stagnant water away from its feet.

The diversity of geological formation and exposure in the apple growing districts of Oregon render this topic of aspect a peculiarly interesting one. In some sections little attention aside from that given to heavy winds is necessary; in other sections the southern exposures, while desirable in many respects, are liable to have a thin soil underlain by impervious rock; in still other sections the northern slopes, ideal in several features, have a soil rich, deep, full of humus, very moist, and thus prone to keep the tree growing too late in the season, and unduly retarding the bursting of the buds in the spring; and in yet other sections the aspect is quite a matter of indifference, as in the Rogue and Grande Ronde river valleys proper. But upon the bench lands of these sections, when more attention is given to the planting of orchards upon them, due attention to aspect will be of no little importance, and may be a deciding factor between success and failure with particular varieties. Especially in Rogue river valley would it appear that the later keeping varieties will demand the cooler northern exposures, while the earlier varieties will do best upon the southern and eastern slopes.

In the Willamette valley, except in the districts tributary to the "gaps" in the Coast mountains, through which strong sea breezes issue, a southern aspect would seem generally desirable, providing it is not a hillside with thin soil. The general low altitude of the valley, together with the average high humidity, makes an open or southern aspect desirable, since under such conditions fruit will tend to take on a higher color, an item of con-

siderable importance in the commercial part of the crop. For early or mid-season varieties, however, and particularly those for home use, where one attaches more importance to fine specimens with clear skins, mellow flesh, and juiciness, and where several days or a week's time in the date of ripening does not detract from the value of the product, a northern, western or sheltered aspect may be of first choice.

While high color is usually a feature of much commercial value in the apple, those who have formed a discriminating taste and grow fruit for their own use, give it but passing notice. Thus it is that the aspect most desirable for the commercial orchard may be of but secondary importance to the home orchardist.

As much of the autumn weather in Western Oregon is of low, light value, owing to the humidity, it is necessary to use considerable discretion when selecting a site for the growing of a commercial apple crop of the late keeping varieties, if one would have a high colored product one year with another. Judicious wood pruning and thinning of fruit will materially aid in enabling the fruit to get the most advantage from the light available.

E. R. LAKE,

Oregon State Board Horticulture, 1911.

Practically all orchardists recommend selecting a sloping site because of the advantage of good air drainage. Air drainage, while not generally considered an important factor in apple growing by the amateur orchardist, is nevertheless one which plays an important part in the success of profitable fruit growing. In the large irrigated valleys in New Mexico it is frequently impossible to consider very strongly the factor of site for the reason that apple orchards are planted as a rule on level ground. In sections, especially in the mountain districts, where a site having good air drainage can be selected this possibility should not be overlooked, since much loss due to frost injury may in this way be avoided. Cold air is heavier than warm air and for this reason it will settle in the low places

which are thus most likely to be the frosty ones

FABIAN GARCIA,

Santa Fe, N. M.

The best orchard sites are usually found on rolling lands or hillsides. In such places better soil drainage is afforded and the likelihood of frosts in the early fall or late spring is lessened. The orchard site should be located far enough above adjacent lands so that the cold air at night can settle below the orchard tract. A few feet in elevation often results in the prevention of frosts in the late spring. Fruit trees should not, under ordinary conditions, be planted on flat bottom land or in low pockets where cold air settles, as such locations are very likely to be frosty.

R. W. FISHER,

Bozeman, Mont.

Elevation

Have the orchard site elevated above the surrounding country. This does not mean that it must be the highest piece of land in the vicinity, but that it should have lower levels in proximity to it. Elevation is an important factor in fruit growing in Wisconsin. There is always a possibility of damage from late spring frosts during the flowering period and orchards on low or level land suffer first. A rolling site which provides good air drainage and which is somewhat elevated is most likely to escape injury from frosts.

Avoid Pockets

Avoid "pockets" It is not only necessary to select elevated sites, but when these sites are in small valleys it is important that the valley be open at its lower end. If it is not, such a valley becomes a "pocket," and because of lack of air drainage is very susceptible to frosts, and unsuitable for apple growing. "Pot-holes," especially if of considerable extent, are best left unplanted as the trees seldom give good results.

J. G. MOORE,

Madison, Wis.

Mississippi Valley Conditions

In locating an orchard a suitable site rather than a convenient one should be the first consideration. Whenever pos-

sible the orchard should be planted on rolling ground or on a gentle slope. Under these conditions both air and soil drainage are provided.

The orchards of the Upper Mississippi valley are particularly subject to damage from late spring frosts. These frosts are always most severe on the bottoms and lower levels. In many instances damage occurs here when the trees on the uplands escape entirely. This is because the cold air, being heavier, naturally settles to the valleys. Parasitic diseases are also much less troublesome on the uplands, since the drier air discourages their growth. The north slope has been often advocated as the ideal orchard site, although any slope is good. The fundamental requisite is to secure a slope of some kind. In many parts of Iowa the land is so level that there is little choice in this regard. Reasonable success may be attained on level ground in the case of the home orchard. It is doubtful, however, if it is wise to engage in commercial orcharding where the proper slope and type of soil are not available.

A. T. ERWIN,
G. R. BLISS,
Ames, Iowa.

Ohio Conditions

While apples may be grown with some success in level sections of the state, it is a very great advantage if the site chosen for the orchard be somewhat higher than the land adjacent. An elevation of even a few feet above the channels or beds of local streams of water will provide not only the necessary water drainage, but also favor frost or cold air drainage which is of almost equal importance. It is a generally well known fact that, under weather conditions which favor frost, the colder atmosphere being the heavier seeks the lower levels of the valleys, ravines and depressions, while the warmer, lighter air envelopes the slopes and summits of the higher ground, often entirely preventing injury by frost in late spring to the blossoms or young fruit. This is especially true of those areas of our state remote from the larger bodies or streams of water. The modifying and retarding influences of Lake Erie upon tempera-

ture, as affecting vegetation, renders a large area of adjacent level land well protected from extremes of temperature

In the valleys of our larger rivers such as the Ohio, Muskingum and others flowing through the rougher parts of the state and bordered along their courses by high hills on either side, it some times occurs during extremely frosty weather that the dense river fogs protect the lower levels from frost while vegetation on the higher altitudes suffers severely. For this reason there may be exceptions made in favor of orchard sites on the more elevated portions of 'second bottom' land of some of the greater river valleys, as that of Ohio; but this will not generally apply to the much smaller valleys of the lesser tributaries.

Humidity and Disease

Excessive humidity in the valleys of the great streams of water favors the development of certain forms of fungi affecting the apple—such as the "sooty blotch" or fungus—which are rarely troublesome on the more elevated sites. As a rule the preference of location for an apple orchard would wisely be given to the elevated hill-slope or summit.

F. H. BALLOU,
Wooster, Ohio.

North Carolina Conditions

There is considerable difference of opinion among fruit men as to what is the best direction for the slope of an orchard. The preferences of different men of experience are so variable as to include every point of the compass. Each slope has its advantages and its disadvantages. A northern slope is a little later in forcing growth in spring, and on that account the bloom is less apt to be nipped by late spring frosts. On the other hand, the fruit on northern slopes, when developing, gets less sunlight and does not have the high colors of that grown on southern slopes. As it is the sunlight that paints the bright colors, the southern slopes always produce the richest-tinted fruit. Southern slopes, too, are the ones from which the sun drinks the moisture most rapidly. They are apt, therefore, to be droughty, and unless the

trees are well cultivated or mulched they will produce small fruit. On account of the continuous loss of moisture from southern slopes it is found that the soils on them are almost invariably thinner and poorer than on northern slopes. Comparisons in the growth of natural forests on northern and southern slopes bear out the same idea. Western slopes give brighter colors of fruit than eastern ones, but they get the hottest rays of the sun, and trees on them are much more subject to sunscald. By care in cultivation and pruning many of the drawbacks due to slope can be overcome, but in any case the sloping lands are to be preferred to level ones for commercial orcharding.

The steepness of the slope on which it is practicable to plant orchards will depend on circumstances. One often finds apple trees in mountain regions that are producing large quantities of beautiful fruit in places that to a plainsman would scarcely seem to be accessible with a flying machine. There is little doubt about the trees doing well on very steep and even rocky locations, but it is often next to impossible to harvest the fruit there economically. Mountain coves, even when high up in the mountain sides, offer the best possibilities for apple growing because they have natural irrigation and excellent drainage, and their soils are usually rich from the washing of the enclosing slopes. Often, while steep, high ridges may be entirely unsuited for apple trees, the coves which they contain may be almost ideal for the same crop. Nature never intended the greater part of mountain lands should bear anything but forest. Man in mountain regions too often invades nature's realm, and thus we see washed and gullied fields on which cultivation is impracticable. Orchards can profitably go higher up the slope than any other agricultural crop, but our better judgment should not allow them to trespass on Nature's domain.

W. N. HURT,
Raleigh, N. C.

Market Conditions

Another all-essential element in locating a commercial orchard is to select a region where there will be ready trans-

portation facilities. Many sections of Idaho grow excellent apples, but in some of these there have been no transportation accommodations developed to handle commercial quantities of this fruit. Undoubtedly it would be unwise to locate large orchards in such sections. Locate the markets and the ways of reaching them first and then the question of the proper location for the orchard can be rationally considered.

In connection with the selection of a section where market communication is guaranteed, advantage should be taken of locating where there are two or more ways by which the fruit may be taken to market. Either two different lines of railroads or a railroad and water-way are decidedly advantageous. These competing lines tend to reduce the freight rates much below that usually maintained when one public carrier has complete monopoly on the entire shipping facilities.

The finished product of an Idaho apple orchard will not endure rough handling if it is to be highly remunerative, hence it is desirable that an orchard should not be in a locality where long rough hauls by wagons are necessary to reach the shipping points. Moreover, transportation by horses is exceedingly expensive even if the roads are not rough and should be minimized as much as possible. * * *

J. R. SHINN,
Moscow, Idaho.

For a commercial orchard it is important to be near a market if a home market is to be supplied, or near a good transportation line if a distant market is to be supplied. It is not essential to be near a market, for many of the large apple orchards are hundreds of miles from the market they supply. It is important, however, to be near a good road and near a railroad, for hauling over a bad road bruises the fruit and thus injures its appearance and keeping qualities. Cost of hauling is considerable if the shipping point is many miles from the orchard. For a home orchard we select a location near the home because convenience is one of the many points to be considered.

H. C. THOMPSON,
Agricultural College, Miss.

Summary

A summary of this subject may be given to aid the reader in reaching a final conclusion in the selection of a site for a home or commercial orchard.

Soil Conditions

Professor William Stuart, of Vermont, recommends for that section a gravelly loam or limestone soil well drained, on an eastern or northeastern exposure.

Professor C. D. Jarvis, Storrs, Conn.: "The ideal soil in Connecticut is a sandy or gravelly loam with gravelly subsoil."

G. F. Powell, New York: "Clay-sand-loam is excellent. Subsoil should not be hard pan."

Professor W. N. Hutt, Raleigh, N. C.: "Mountain coves are ideal for orchards because they have plenty of humus and nitrogen."

Professor J. D. Moore, Madison, Wis.: "Clay loam is excellent if not too heavy. The top soil is not so important if underlaid with pervious limestone subsoil. Gravelly subsoil would be second choice."

Professor G. R. Bliss, Ames, Iowa, says: "In this state the white oak soil is well adapted for orchards. Loose prairie soil is also good as the roots permeate it readily. Black prairie soils rich in nitrogen cause an excess of wood and leaf growth and lessen the production of fruit buds, making the tree liable also to winter injury."

Professor F. H. Ballou, Wooster, Ohio: "Potassium, phosphorous and nitrogen in the quantities furnished by decaying vegetation, especially the legumes, give the best ration."

G. B. Brackett, Washington, D. C.: "Wood growth is strong on loamy soils and liable to winterkill. Clay produces hardy trees. Clay top and free subsoil give excellent results. Cleared forest lands preferable."

Professor Ernest Walker, Fayetteville, Ark.: "The orchard should have good drainage, deep soil, and plenty of lime or limestone."

Bulletin No. 112, Baton Rouge, La.: "The difficulty in Louisiana is that there is so much moisture and fertility that orchards tend to produce too much wood

growth. The higher elevations and heavier soils are better than the lower elevations and lighter orchard soils"

Professor H. C. Thompson, Agricultural College, Mississippi: "A deep rich clay with but little nitrogen should be selected. Soils very rich in nitrogen produce too much wood growth."

Professor Fabian Garcia, Santa Fe, N. M. says that the adobe soil in that country is not good, but that a good strong loam to a depth of six or seven feet underlaid with adobe is an ideal situation.

Professor R. W. Fisher, Bozeman, Mont.: "Loam, moist but well drained, deep and composed of limestone, granite, or volcanic ash with plenty of humus is best."

Professor J. R. Shinn, Moscow, Idaho: "The soil best adapted is one from which native forests have been cleared. It should have good water drainage, good texture and be rich in plant food. Tile should supply drainage if natural drainage is wanting."

Weather Conditions

Professor C. D. Jarvis, Storrs, Conn., says that on account of the purer air and brighter sunshine fruit that is grown on the higher elevations is better. A southern slope offers relatively more sunlight than any other. There is little danger from frosts on a southern exposure if proper attention is given to elevation.

Professor W. N. Hutt, Raleigh, N. C.: "Southern slopes always produce the richest tinted fruits, but are more subject to drought, and the soils are generally thinner. Western slopes are hotter than eastern and the trees are more likely to sunscald. The conditions that produce heavy timber will produce good fruit trees."

Professor G. B. Brackett, of the United States Department of Agriculture thinks that an eastern or northeastern exposure is better than any other.

Professor J. G. Moore, Madison, Wis.: "Avoid pockets and small valleys not open to air drainage at the lower end of the valley. Near large bodies of water the best results are obtained by having the orchard exposure in the direction of the water."

Professor F. H. Ballou, Wooster, Ohio: "Should be located on elevated lands adjacent to large bodies of water if possible."

Professor H. C. Thompson, Agricultural College, Mississippi: "A northern slope in Mississippi is best."

Professor J. R. Shinn, Moscow, Idaho: "Apples have been grown at elevations of 6,000 feet, but the profitable commercial orchards are below 3,000 feet. A location near to markets is very desirable."

Professor R. W. Fisher, Bozeman, Mont., thinks that the best soils are rolling lands on hillsides because soil drainage and air drainage are better on these rolling situations, and there is less danger of frosts.

Market Conditions

Professor F. H. Ballou, Wooster, Ohio: "The orchard should be near a good shipping point, a large town is better than a small one."

Professor H. C. Thompson, Agricultural College, Mississippi: "Locate the orchard near a good road and near a railroad, for the danger of bruising fruit and the cost of hauling are considerable."

PREPARATION OF LANDS FOR ORCHARDS

Timbered or Rocky Land

In the case of land that has been covered with timber or of rocky land, it is better before planting the trees to remove all the stumps and large rocks, because if the trees are to be properly lined in straight rows, stumps or rocks may interfere with the setting. I saw an orchard of several hundred acres in the Ozark mountains that was set on land where the underbrush had been grubbed and the large timber cut down and allowed to lie on the ground to rot while the apple trees were growing. This was not a satisfactory arrangement, because there could not be a proper alignment of trees, and the land could not be cultivated and kept free from weeds and wood growth that sprang up from the roots of trees. At the same time there was more or less danger from injury by forest fires that might catch in the dry brush. The theory of the owner was that the decaying timber would fertilize the land, and that if he waited to clear the land entirely

the orchard would be delayed one year, but he discovered later that he would have gained time by waiting another year, and supplying the land with fertilizers, in the form of cover crops.

No General Rule.

Many things have to be left to the common sense of the man who grows an orchard. It is not possible to lay down a set of rules that are elaborate enough for guidance in all places. Generally, however, the land should be properly leveled. This is especially important in irrigated sections where water must be conveyed to every part of the orchard. It may cost \$10, \$15 or even \$25 per acre to level land for proper irrigation, but if it must be done, it pays to do it before planting, because if the trees are set out before leveling, and the elevations lowered and the depressions filled after the setting of the trees, the soil will be carried away from the trees set on the high points and given too great a depth on the lower portions; thus in one part of the orchard the roots of the trees will be too near the surface, and in another part too far below the surface.



Fig. 1. A Sage Brush Grubber. Baker Manufacturing Co.

Hard Pan Near Surface

Where there is hard pan or a thin stratum of rock near the surface, it can often be broken up with dynamite, and the lower stratum of soil reached, so that the roots of the trees will not be obstructed but will take hold of the lower stratum.

In some cases this might not be a favorable condition, because there may be places where the root system would lack aeration, where the air is obstructed by a thin stratum of rock or of hard pan; but we have seen trees growing under similar conditions where they seemed to be healthy and vigorous, and apparently had not suffered from lack of aeration.

Surface Rock

As to small rocks on the surface it may be better to remove them before planting, but except in so far as they interfere with cultivation it seems to us to make little difference whether they are removed or not. It is claimed that surface rocks are an advantage, aside from the difficulty of cultivation, because they absorb the heat more readily during the day and during the night radiate it more rapidly than the soil, thus warming the surrounding atmosphere. Whatever may be the disadvantage of rocky surfaced soil, I have seen some very excellent orchards growing where the surface was well covered with rock.

GRANVILLE LOWTHER

LOGGED-OFF LAND

Cost and Methods of Clearing

The following facts are the result of investigations begun by the Department of Agriculture in 1908 in Western Washington and in co-operation subsequently with the states of Washington, Wisconsin and Minnesota.

Bibliography

Farmers' Bulletin No. 462—"Utilization of Logged-off Land for Pasture."

Farmers' Bulletin No. 137—"The Angora Goat."

Washington Bulletin No. 78—"The Goat Industry in Western Washington."

Washington Bulletin No. 101.—Sparks.

U. S. Department of Agriculture, Bureau of Plant Industry, Bulletin No. 239.

Usually logged-off land in Washington and Oregon is left thickly covered with stumps, snags, and scattering trees without commercial value, as well as brush and logs. The cost of clearing such land is dependent upon the number and size of stumps left, the quantity of debris

and the character of the soil from which stumps are to be removed. The fir lands of Western Washington and Oregon are the most expensively cleared of all such lands.



Fig. 1. Typical Clearing in Western Washington.

Slashing

Logged-off lands on the Pacific Coast very quickly grow up to young trees and brush and the first step in the process of clearing it is to slash this young growth. This should be done in early summer for two reasons, the first being to give time for some drying to occur before burning and the second that sprouting from the stumpage is not so apt to occur.



Fig. 2. Typical Stump To Be Removed.

Windfalls should be brought down to the ground and large logs split open enough to allow them to dry out somewhat.

It is an economy to pasture land for a few years after the slashing has been burned to give time for small stumps and roots to decay. Goats and sheep are especially valuable for this purpose particularly in the case of maple and alder bottoms since they keep down sprouts. The claim is made that flocks will pay

for their first cost in reducing the expense of clearing, the product of the flock thus becoming a clear profit.

Removing Stumps

The following methods are used: Blasting, stump puller, stump puller in combination with blasting, burning.

Blasting

A word should be said at the outset relative to the supposed injury to the soil by powder. No chemical injury is done to soil by the use of powder. It must be remembered, however, that in blasting out a quantity of large stumps in a soil closely underlaid with clay, sand, gravel or hard pan, much of the poor subsoil is likely to be thrown out upon the surface and in this way have injurious effect.

Powder Used

Space cannot be here given to methods of handling the powder.

That most commonly employed is a 20 per cent nitro-glycerine powder for warm weather and a chlorate powder for cold weather as the latter does not freeze.

Placing the Powder

Tools employed are a bar six to seven feet long made by welding a rounded steel dub at one end and a chisel at the other end of a one and one-half inch gas pipe, the round end being used for thrusting aside gravel in the auger hole and the chisel end for cutting roots, a three-inch auger with a long shank, a long-handled spoon or shovel, and an ax.

By means of these tools the operator makes a hole large enough for his charge



Fig. 3. Beginning the Boring of Holes Under Stump for Blasting.

Fig. 4. Finishing Boring of Holes Under Stump for Blasting.

at the point which, in his judgment, is the center of resistance of the stump, one to three feet below the level of the ground. The amount of powder used will be determined by experience although there is no economy in tearing a stump all to pieces.

Cost of Blasting Stumps

By this method the government experts removed green fir stumps from sandy, gravelly loam, the stumps ranging



Fig. 5. Two Stumps Whose Roots Are So Grown Together That a Single Charge Cannot Be Placed to Blast Them Economically.

Fig. 6. The Result of a Battery Shot Upon the Stumps Shown in Fig. 5.

from 18 to 60 inches in diameter at the ground, for an average of \$1.40 each, including labor. From three to forty sticks of 20 per cent nitro-glycerine powder were used and the holes dug varied from 24 to 50 inches in depth. The cost ranged from 35 cents to \$2.88 per stump.

Old fir stumps are not quite so costly to remove as green ones. Stumps five years old were removed at an average cost of \$1.18 each. Some of these stumps were as large as 76 inches in diameter at the ground.

Five-year-old cedar stumps in gravelly soil come out for an average of \$1.12. Some of these stumps were 120 inches across at the ground. Twenty-four sticks of 20 per cent powder was the highest charge used.

Cottonwood stumps cost \$1.90 on the average, some stumps costing as much as \$3.36 to remove.

Old spruce stumps were removed for \$3.39 each and alder stumps for 40 cents. The spruce and alder stumps were in silt soils.

Charges may be fired either by safety fuse or electric battery, the latter method being surer and safer as well as slightly more economical. The charge is placed, fired and tamped the same as when safety fuse is used, a six-foot electric fuse being

the best for general use. The connections are made in such a way as to make a continuous circuit of all fuses with the battery, which should be placed at least 300 feet distant behind a tree or tall stump, for safety. Insulated copper wires are used for making connections and all ends should be scraped bright before connections are made. Tape should be used for wrapping in damp weather or on wet ground. The blasting machine may be had of any supply house or is supplied by the powder company.

Stump Pullers

Stump pullers in Western Washington are unsatisfactory as compared with dynamite. Two types have been in use—that which is hitched to the top of the stump, pulling it over laterally; the other hitching under the roots and lifting it out vertically. The failure of the latter is largely due to the great amount of work necessary in getting hitched up to the stump and the frequent moves that have to be made; a new "set up" being required for each stump.

For either of these machines large stumps have to be cracked with a light charge of dynamite.

With stump pullers it costs on an average about \$3 per stump to remove them.



Fig. 7. Hercules Puller.



Fig. 8. A Stump Puller That Lifts the Stump Vertically Out of the Ground.

The Donkey Engine

More land has been cleared in Western Washington by means of the donkey engine than by any other agency since this method came into use. As a rule in Washington outfits for clearing have been used-up logging rigs, and as a consequence, results have been less favorable than they otherwise might have been. Equipment should consist of a large double drum engine (10x12 to 12x14 cylinder) with tackle consisting of 1,000 feet of 1½-inch main cable, 2,000 of 5/8-inch haul-back line, four 1-inch guy lines, two 10-inch pole blocks, four 8-inch blocks for haul-back line in the field, lead lines, chokers, extras and tools.

Logs and stumps should be piled as high as possible for burning, hence a gin pole 60 to 100 feet high is most commonly used. The crew is made up of en-



Fig. 9. A Tall Gin Pole and a Good Pile That Will Burn Well.

gineer, fireman, pile man (except where automatic self-releasing choker is used), hook tender, and assistants. Tracts to be cleared should be slashed and burned and stumps previously blasted so as to split and loosen them. The gin pole can be set in the center of a 10-acre tract, or at a center where not over 500 feet of haul is made.

Gin pole and engine are guyed to stumps or "dead men" sunk four to six feet deep. The accompanying diagram illustrates method of setting.

The following specifications and estimate for a donkey engine outfit are taken from the article by Harry Thompson in U. S. Bureau of Plant Industry, Bulletin No. 239.

A compound-gear yarder, with two speeds to the main drum, giving approximately 100 and 250 feet per minute, with the haul-back geared to run at 300 to 350 feet per minute, is required. The cylinders should be 9x10 or 10x12 feet. The hauling drum should be fitted with a steam friction. The boiler should be extra large. There should be 1,000 feet of 1½-inch main line of six strands of 19 wires each and 2,000 feet of 5/8-inch haul-back line of six strands of 19 wires each.

Estimate of Cost of Donkey Engine Outfit

Engine and boiler.....	\$3,500
Main line	200
Haul-back line	150
Bull block for gin pole.....	75
Six self-releasing chokers (¾-inch, 7/8-inch and 1-inch).....	60
Four haul-back blocks, hooks and swivels.....	70
Four 1-inch guy lines, 250 feet each.....	150
One lead block for haul-back line.....	35
Electric-signal outfit	10
Tools, extra hooks, blocks, etc.....	150
Total	\$4,400

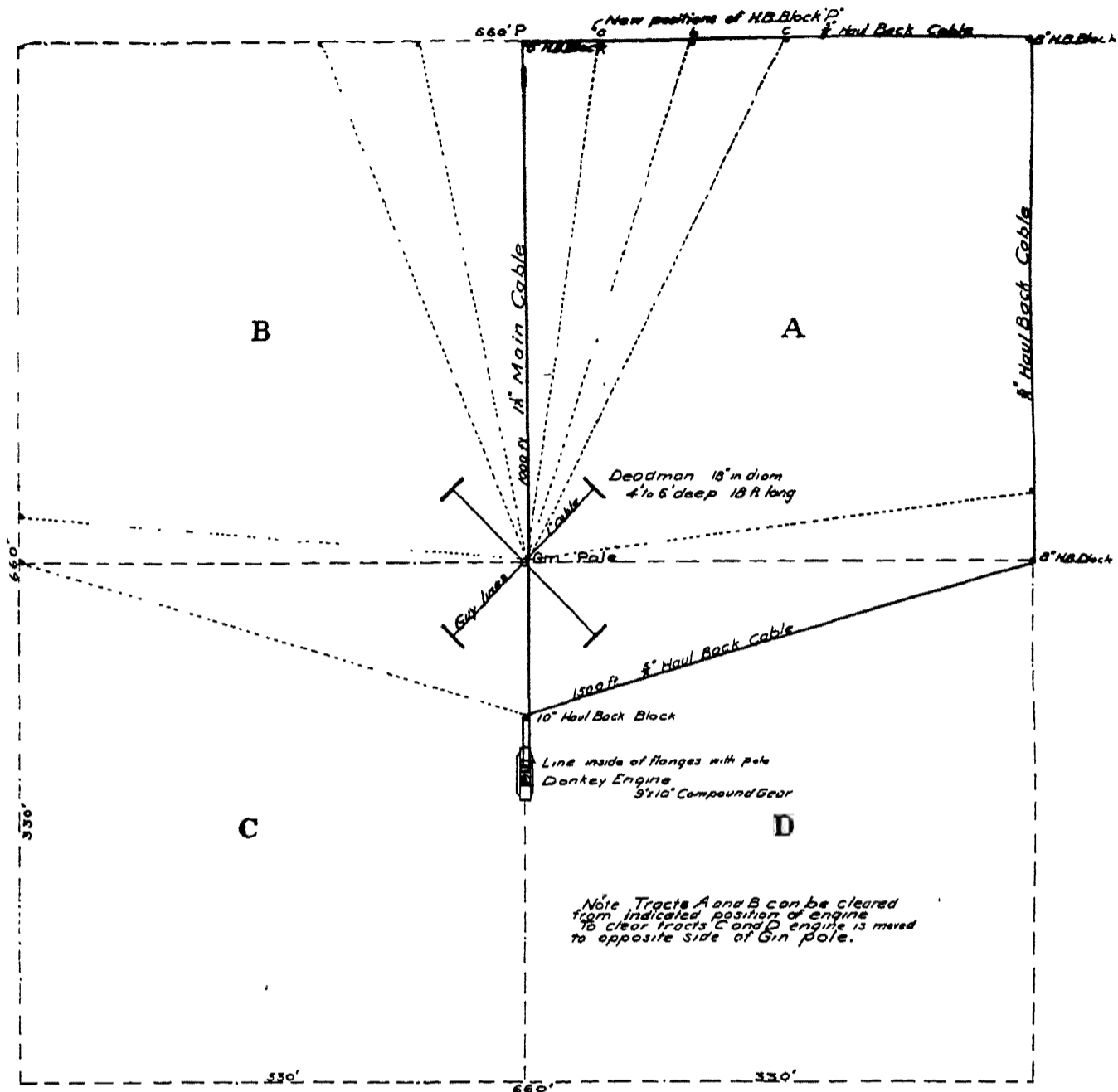

PLAN
 Showing Position of Donkey Engine
 and Rigging for Clearing a Ten Acre Tract
 scale 1"=50'

While this outfit is too expensive for small owners, it could be purchased by a community, or one or more such outfits could be operated by a county or a large company for clearing land. It would be more satisfactory than the makeshift outfits usually found doing this work.

Cost of Clearing Land With Donkey Engine

The costs here given are taken from actual records of 18 different tracts ranging in size from 3 1/2 to 19 acres and totaling 150 acres. Various conditions of soil from silt loam to gravel were encountered. The average number of stumps per acre

varied from 14 to 56 which ranged in average size on the various tracts from 19 to 52 inches at the ground. The cost of explosives ranged from \$4.77 to \$86.04 per acre the average being \$21.12. The total cost including labor averaged per acre on the various tracts from \$47.40 to \$222.87, the average of all being \$66.44. This represents the entire cost including burning and clearing small stuff after the stumps and large logs were out of the way.

The whole cost of clearing if charged to the stumps on all the tracts would bring the cost of the stumps to \$2.54 each. The

entire cost of clearing the 18 tracts comprising 150 acres was \$11,782.50 and the whole number of stumps removed 4,633.

Gasoline Engines

Small gasoline engines hitherto tried have proven unsatisfactory.

Burning

All ordinary methods of burning have proved unsatisfactory for the reason that they burn off the top of the stump leaving the roots in the ground.

The Blowing Machine

Outfits of this kind cost from \$350 to \$500 complete and consist of gasoline engine, blower and distributor with lines of hose. They have not proven efficient on account of cost of operation and the fact that they do not burn the roots out deeply enough.

Char Pitting

This method is best employed late in the summer on at least one year old

stumps, bark having been removed in the spring. Fir stumps are more easily treated than cedar on account of the pitch in the roots. A clay soil is requisite for covering, as sand dries out and sifts down, putting out the fire.

The method of char pitting is to pack small sticks and chunks of wood about the roots of the stump, cover these with ferns or grass to prevent the sifting of loose earth on to the fire, then cover the whole with two to three inches of clay packed snugly about the stump to prevent draft.

Fire through a small opening and cover after the fire is well started.

Stumps must be watched closely for a day or so, after which they will burn out with attention given twice a day.

Another method is to dig, in spring or early summer, a hole under the stump between two large roots large enough for an armful of kindling. In the fall or late



Fig. 11. A Stump, with the Bark Removed, Ready for Char Pitting.
 Fig. 13. Kindling Covered with Ferns to Prevent the Fine, Loose Earth from Sifting Into It.

Fig. 12. Kindling in Place Around the Stump.
 Fig. 14. Earth Covering in Place. Opening Left at Which to Light the Fire.



Fig. 15. A Stump That Has Been Burning Five Days. The Clay Covering Has Reached Half Way Round the Stump.

Fig. 16. A Stump Around Which the Banking Has Been Completed. The Stump Is Burning Near a Barn During the Dryest Season of the Year with Very Little Danger to the Building.

summer fill this hole with dry kindling and after firing cover with clay, extending the cover around the stump as the fire progresses until it is completely burned out.

Both methods are efficient and cheap. The method does not succeed in sandy soils as the falling sand prevents the burning to sufficient depth to permit plowing. It is useless to attempt the method during the wet season.

Cost

The cost of this method is somewhat below that of the others enumerated, being from \$50 to \$75 per acre, or if charged to the stumps, running from 30 cents to \$1.00 per stump. One advantage of the method is the fact that no expensive equipment is required and the work can be done by the owner.

Conclusion

It will be seen from the foregoing data that a man without capital can not hope to clear in a short time a large enough tract of land upon which to support a family. Under the most favorable conditions and with the lightest clearing ground the cheapest rate at which logged-off land can be prepared for the plow is \$50 per acre. The maximum should not ordinarily exceed \$150 per acre, although there are exceptional tracts that will cost \$200 per acre to clear. This shows that it is no small undertaking to make a farm out of this land and that it is not feasible for the poor man unless he has other em-

ployment to provide sustenance for himself and family while the clearing is in progress. It is the opinion of all who have carefully studied this problem that work of this kind ought to be done on a large scale, at a small profit, for the public good. Possibly the aid of the state will be required before these wastes are made into agricultural land.

The donkey engine method of clearing is a very efficient and serviceable one. Where it is well equipped and properly managed the expense need not be prohibitive. Extra expense in most instances is due to poor equipment, lack of experience, and bad management. Most of the clearing that is being done at this time is by the donkey engine method.

Donkey engine outfits could be purchased by the county or community. By employing one or two experienced men the other work could be done by the owners of the land to be cleared. In this manner the expense could be kept down to a minimum. A donkey engine outfit could be used to advantage in connection with the char pitting method to pile the burned-off tops of the stumps, logs, and debris when the work is done on a large scale.

Powder plays an important part in the clearing of logged-off land, as a powerful agent is required to dislodge large stumps. All of the devices for pulling large stumps are dependent on powder to split and loosen the stump before it is pulled. A cheap explosive would be an incentive toward clearing land.

The blowing machine and other devices for the destruction of stumps, while yet in the experimental stage and by no means perfect, may develop into cheap and efficient methods of clearing land.

Wherever the char pitting method can be used successfully it should be employed as it is the simplest, cheapest, and most efficient of all methods of clearing land where the conditions are favorable. In unfavorable soil it is liable to leave too many unburned roots in the ground. Surface clearing, as the method which leaves the roots under the surface is called, is the worst form of clearing possible.

Many purchasers of cleared land after paying a large price have found that only the surface had been cleared and that the land could not be cultivated until the roots were removed. Experienced men would rather have the stumps where they can be seen than have them cut off and covered up.

(Arranged by Wm. Worthington from Bureau of Plant Industry Bulletin 239 by Harry Thompson.)

Clearing in Irrigated Sections

Since all our apple orchards in New Mexico must be irrigated, it is necessary that before planting the trees the land be prepared as much as possible in order to facilitate irrigation. As a rule it is best, if it is new land, and especially one with sand hills all over it, to break it up and plant it to some hoed crop the first year. In this way one will get the land in better shape for the trees the following season. In the Rio Grande valley sandy

spots which have been leveled down are usually very deficient in plant food, and it may take two or three or even more years to get the soil where these sand hills were to be as fertile as the rest of the land. The land to be used for an orchard should be deeply plowed and harrowed before planting. After the land has been properly plowed comes the question of how to lay it off in order to irrigate the young trees most economically and to the best advantage. A very good method is to plow out small ditches about one or two feet wide at the bottom. Plant the trees in the bottom of these ditches. These ditches will serve for irrigating the trees the first and even the second year, without having to irrigate the middle between the trees. This is a very important point to consider and especially so where water is expensive, or where the middles are not to be planted to crops.

FABIAN GARCIA,
Santa Fe, N. M.



Uncleared Sage Brush. Brush of This Size Usually Indicates a Deep Fertile Soil.

TABULATED STATEMENT SHOWING COST OF PLACING RAW LAND IN CROP IN WASHINGTON

NOTE—Each line of the accompanying tabulation represents the report of an individual grower.

County	Postoffice	Size of tract in acres	Clearing	Plowing	Scraping	Leveling	Planting	Cost of seed or trees	Ditching	Other expenses	Total cost	Average cost per acre	Remarks
Asotin	Vineland	5	\$ 10.00	\$ 15.00			\$ 50.00	\$145.00			\$225.00	\$ 45.00	Planted to peaches, berries and grapes (1,400 vines).
Asotin	Vineland	15		22.50			100.00	325.00	\$100.00		547.50	36.50	Planted to peaches and cherries
Benton	Kennewick	30	30.00	150.00	\$ 60.00	\$ 90.00	60.00	748.50	30.00	\$200.00	1,468.50	48.95	Planted to orchard and grapes
Benton	Kennewick	40	120.00	100.00		190.00	280.00	897.60	1,168.00	85.00	2,341.30	71.03	Planted to orchard—Ditching includes a pipe line
Benton	Prosser	11	24.00			125.00	24.00	85.00		55.00	313.00	28.45	Planted to apples
Benton	Kennewick	10	30.00	22.50		100.00	22.50	25.00			200.00	20.00	Planted to alfalfa
Benton	Kennewick	5	15.00	5.00		24.00	40.00	200.00	15.00	50.00	349.00	69.80	Planted to cherry, peach and pear trees
Chelan	Entiat	15	150.00	45.00			30.00	225.00	200.00		650.00	43.33	Planted to winter apples.
Chelan	Wenatchee	36	108.00	72.00			108.00	360.00	108.00	144.00	900.00	25.00	Planted to apple trees
Columbia	Dayton	6		20.00		10.00	22.50	165.00	22.00		239.50	39.91	Planted to apples and peaches
Douglas	Wenatchee	40	80.00	160.00			240.00	810.00		600.00	1,890.00	47.25	Planted to apple, peach and apricots
Garfield	Pomeroy	25	150.00	25.00	25.00	15.00	25.00	45.00	500.00	200.00	985.00	39.40	Planted to orchard and alfalfa
Okanogan	Omak	37	166.50	92.50		370.00		200.00	500.00	150.00	1,479.00	39.90	Planted to apples and wheat
Okanogan	Brewster Flats	10		30.00	10.00	10.00	40.00	140.00	50.00	10.00	290.00	29.00	Planted to apples and peaches
Okanogan	Omak	40		90.00	100.00	50.00	175.00	600.00	50.00	135.00	1,200.00	33.33	Planted to general orchard
Spokane	Otis Orchards	20	130.00	70.00		15.00	70.00	303.80			588.80	29.44	Planted to general orchard
Spokane	Otis Orchards	13.3	70.00	78.00		20.00	54.00	280.00		20.00	522.00	39.25	Planted to general orchard
Spokane	Spokane Bridge	10	100.00	60.00		10.00			5.00	20.00	195.00	19.50	Expense of trees and planting not shown
Spokane	Otis Orchards	12		39.60		15.00	36.00	240.00		100.00	430.60	35.88	Planted to apple trees
Walla Walla	Two Rivers	5	12.50	12.50	5.00	5.00	25.00	19.50		11.75	91.25	18.25	Planted to trees and garden
Walla Walla	Walla Walla	14	70.00	17.50		350.00	30.00		25.00	37.00	529.50	37.82	Planted to general garden
Yakima	North Yakima	10	50.00	50.00		150.00	50.00		50.00	10.00	360.00	36.00	Planted to apple trees
Yakima	Grandview	20	100.00	40.00		300.00	50.00	320.00	10.00		820.00	41.00	Planted to orchard
Yakima	Mabton	15	75.00	37.50		225.00	60.00	240.00	15.00		652.50	43.50	Planted to orchard and alfalfa
Yakima	Sunnyside	2	6.00	5.50		1.00	1.50	4.50	1.00	29.50	49.00	24.50	Planted to tomatoes
Yakima	Mabton	7	35.00	17.50		93.75	7.00	3.00	.50	10.00	166.75	23.82	Planted to alfalfa

SUMMARY

Number of counties represented	10
Number of tracts considered	26
Total acreage	453.3 acres
Average size of tracts	17.43 acres
Average cost of placing raw land in crop, including clearing, plowing, scraping, leveling, planting, cost of seed or trees, ditching and other incidental expenses	\$39.66 per acre

Bureau Statistics and Immigration, Irrigated Lands. 1910. Olympia, Wash.

Brush Land

Much of the orchard planting is being done on rough brush land. Some growers have planted the trees after simply cutting and burning the brush, leaving the plowing and harrowing till later in the season. There is a strong objection to this method for the subjugating process is rendered more difficult by the presence of the trees, and even with the utmost care some trees are sure to be injured. A more satisfactory method is to fit the land the first season and set out the trees the following spring. There would be no loss of time by this method if the trees are purchased the first season and planted in nursery rows for a year. On account of the trees being limited to a small area in this way they may receive the very best treatment and may be properly trained. Any one who is contemplating the clearing of rough land is advised to consult some of those who have had experience in such work. Briefly, the operation consists in cutting and burning the brush, removing stumps and stones and plowing and harrowing. In some cases where the growth is small the brush may be cut with a mowing machine or with brush scythes, and gathered up with a horse rake. A modern stump-puller may be used to advantage, but the work is more frequently done with dynamite. When they do not interfere with the locating of the trees, the larger stumps are sometimes left to decay, but in order to facilitate cultivation it is usually best to remove them at the time of clearing. The plowing will be a rough job at best, but two or three times over with the cut-a-way harrow will compensate for all irregularities. The work should be commenced as early in the season as possible so as to have the ground ready for a cover crop by the first of August. Where there are many large weeds and other herbage buckwheat is probably the best kind of a cover crop for the first season. If the ground is in good condition of tilth it may be advisable to use clover, which is more valuable from the standpoint of fertility, but lacks the characteristic "smothering" action of

buckwheat. Clover has the advantage also in that covers the ground and prevents washing during the winter and spring. In the following spring the cover crop should be either ploughed under or worked into the soil with a cut-a-way harrow. The work should be started early enough to permit at least two harrowings before planting. Old pasture land, and even land that has been under cultivation, should have the same treatment with regard to tillage and cover cropping. Much of the run down land of the state is sadly in need of humus, or decaying vegetable matter, and the turning under of a cover crop will go a long way toward restoring fertility and making the land productive. Any land, and more particularly pasture land, should be very deeply ploughed or subsoiled before being used for orcharding. Subsoiling is almost out of the question on stony land, but the necessity for it on such land is not so great.

C. D. JARVIS,
Storrs, Conn.

Preparing the Land Plowing

The principal requirement in preparing land for planting an orchard is deep tillage, and the more thoroughly this work is done the more certain is success. The preparation had best be done late in the fall, so that the land will be ready for early spring planting or for fall planting, if preferred. Many successful orchardists, especially in the western states, plow the ground in "lands" so as to make an open land furrow where each row of trees is to be set, and then, after the trees are planted, back furrow the ground so as to make lands with tree rows in the center.

This method affords a deeper tilth under the trees, and at the same time surface drainage into the open land furrows midway between the rows, which will receive and, if properly graded, carry off any surplus water which may accumulate from heavy rainfalls.

G. B. BRACKETT,
Washington, D. C.

Sod Method of Reducing

It is never advisable to plant orchard trees in fresh sod. In preparing sod land, it is best to plow in mid-summer and cross-plow it again in the fall, leaving it in the rough through the winter. Fall plowing is advantageous in any case, as it helps to destroy many insect pests such as cutworms and also insures a thorough pulverizing of the soil. Early in the spring the ground should be disked and harrowed until it is mellow. It is also advisable to go over it again with the harrow just before planting to destroy any weeds that have started. Many orchardists follow the plan of plowing the ground in long narrow lands, back-furrowing just the width desired for a tree row and leaving the dead furrow where the line of trees is to run. After the trees are set the ground is again back-furrowed, this time throwing the dirt towards the trees. The general experience of the older orchard sections is in favor of the level system.

A. T. ERWIN,
G. R. BLISS,
Ames, Iowa.

Deep preparation of orchard land a year or two previous to setting trees is highly desirable. Wet places should be drained and perhaps limed. Poorer soils should also be well fertilized and have the manures worked deeply into the soil. Special attention must be given to thin places. Such preparation favors a vigorous start and a deep running root system.

ERNEST WALKER,
Fayetteville, Ark.

Time to Prepare

The autumn months are regarded as the best time to prepare all lands that are to be planted to apple orchards. This exposes the land to the ameliorating effects of frosts, allowing such soil to catch and hold the rainfall of winter, and permits the subsoil to become sufficiently settled to re-establish capillary action between it and the lower soil strata while still keeping the soil in loose condition for the deep penetration of the roots. If the autumn preparation is thoroughly

done, the stirring of the surface is all that will be needed in the spring.

J. R. SHINN,
Moscow, Idaho.

Preparatory Cropping

The thorough preparation of the land should be regarded as a very important element in planting an orchard. An apple orchard is very different in its requirements from an annual crop; yet how frequently does it occur that the land for it receives even less attention than does the land for corn or wheat? Many prospective orchardists propound as their first question, "How are we going to rid the land of sagebrush or stumps for setting our trees?" They think when this matter has received attention that trees may be set at once. While it is true that some lands may be turned over and planted immediately, yet most experienced growers and observers regard the practice as of doubtful value. The wiser plan is to anticipate planting two or three years in advance and devote this time to growing a rotation of crops which will bring the soil into the best state of cultivation. After the roots of the trees have taken possession of the soil, deep plowing can not be done; and as this is essential the soil should be plowed deeply before planting. For arid lands in sagebrush sections the need of organic matter in the soil is apparent to the casual observer, and no crops act so beneficially in increasing this organic matter as alfalfa or clover. After clearing new lands alfalfa or clover may be sown, which should be allowed to remain one or two seasons, after which it is turned under. By virtue of their extensive root systems, better crops than these are not known for breaking up soils underlaid with stiff clay. Where soils are sufficiently supplied with organic matter there is less need for the above practice. New ground, however rich, needs to be subdued before trees are set upon it. Such lands are apt to be full of inequalities; hence every effort should be made to discover and remedy the poor spots that need manuring and the wet spots that need drainage, so that the trees when planted

may grow evenly and rapidly from the very start.

Cereal Crops as Indices

The cereal crops such as wheat and oats serve admirably as indices for bringing out these inequalities. Immediately preceding the planting of the orchard a crop that requires thorough cultivation, such as potatoes, is highly beneficial in putting the finishing touches upon this preparatory cropping system.

J. R. SHINN,
Moscow, Idaho.

THE NURSERY

Growing Apple Seedlings

The seeds for the growing of "apple seedlings" are generally taken from the cider mill. Those who prepare them commercially, wash them out of the pomace, store them in a damp place, and, just before shipping, dry them so that they will not mould. If they are to be planted in a large way and drills used for the purpose then the seeds must be dried in order that they may drop evenly. Very often the seed is planted with the pomace, and this, for the ordinary grower not too far from the cider mill, is probably the best way.

Germination

There is one peculiarity of apple seeds that must be met when considering the question of planting. It is that they do not readily germinate if planted in the spring without having been soaked in warm water or frozen. There is a kind of hard substance encasing the seed hull that must be broken or rotted before the germ will grow. This may be done by soaking in water from 12 to 20 days; or it may be done by freezing.

Method of Planting

A good way to plant is to sow in drills, the rows about two feet apart, with the seed lightly covered so that they will freeze during the winter. If the seed is frozen it will come up with the approach of warm weather in the spring. If it is not frozen it will not come up until the following spring. Another method is to put the seed out on the ground in a pile and keep it damp, so that when the freezes of winter come it

will be prepared for germination. When it is ready for planting it germinates and grows much like other crops and needs substantially the same care

Soil

The soil should be a deep rich loam, because in such a soil there will grow good large roots on which to graft. The land should be plowed deeply and well pulverized.

Amount of Seed

There is considerable difference of opinion as to the amount of seed required with which to plant an acre and planters advise anywhere from one to three bushels.

Cultivation

With the rows two feet apart a small cultivator can be run between them, or a larger one can be so arranged as to cultivate two to four rows at one time. The cultivation should be thoroughly done; for a little delay will sometimes allow the weeds to get the start of the plants, and that causes a great amount of extra work.

Mow the Tops

In the autumn when the plants are gathered in they should be cut off with a scythe or mower near the ground, or at any rate not more than nine inches high, since this lessens the weight and bulk of the materials handled and can be done with much less labor than by any other method of cutting.

Harvesting

When this is done the plants are ready to be removed. One of the best methods of doing this work is to run a furrow on either side of the row, a second plow, made especially for the purpose, cutting under the trees, and leaving them standing in the row. Then the plants can be easily pulled and placed in bunches. These bunches are tied and buried in trenches or beds until the leaves are loosened and will drop. From these beds they are taken to the counting room where they are graded and counted, either 100 or 200 in a bunch, when they are planted out in the nursery rows from which the apple trees in the nursery come.

GRANVILLE LOWTHER

Propagation of Apples

Directions for Budding and Grafting

*The apple is propagated either by budding or grafting. Grafting is the more common way, and is the method in most general use. There are two principal forms of grafting; first, the whip or tongue graft, usually employed in uniting a piece of an apple twig to a section of an apple root; second, the cleft graft, employed in top working either young or old trees in the field.

Scions

A scion is a twig from a tree which is to be used for grafting purposes. Scions for root grafting may be taken from the trees at any time after the leaves have fallen, but it is much better to cut them before the first hard freeze. Never cut scion wood from trees while frozen. If cold weather comes on suddenly before the scions are taken, wait until they are thawed out. First, decide what varieties are wanted, then go to healthy trees of the desired kinds that are known to produce good crops, and cut from them the best twigs of last season's growth. Wood that is two years old is not suitable for grafting, although it will sometimes grow. Where scion wood is taken from a young tree it is often possible to get twigs as much as two feet long, but they can be used quite as well if the growth is not more than six or eight inches, which may be the case with old trees. Well-matured water sprouts are sometimes used. If water sprouts are taken be sure they arise far enough above the ground to be certain that they have not come from the roots of the tree, which would make them seedlings. Never make the scions of soft, spongy, immature wood, or from any which has refused to shed its leaves. If the scions are taken in fall or early winter, they must be packed in green sawdust and stored in the cellar like the stock (roots).

Scions should not be permitted to either freeze or dry out while in storage. It should be remembered that when fruits are grafted the variety is determined by

the scion. As a rule, the root has little or nothing to do with determining the size, color, shape or taste of the fruit. However, the vigor of the root does have a great deal to do with the size and longevity of the tree that results from the scion that is grafted upon it.

Where a long scion and a short piece of root are used the former will very likely take root itself above the stock. By many this is considered to be highly desirable, and in such instances it is said that the trees are "upon their own roots." Where a long root is used with a very short scion, the point of union will be so near the surface of the ground that there will be great danger that sprouts will arise from the roots which, of course, would make seedling trees.

Making the Grafts

The grafting is best done in a cellar or basement room or may be performed in a moderately warm room, if precautions are taken to keep the wood from drying out. Keep packed up until ready to use, and repack as soon as the work is over. With the exception of the few pieces that are being handled, the remainder should be kept covered with a piece of moist cloth. Do not work about an open fire or near a hot stove, as both the roots and twigs may be dried out and seriously injured. Grafting may be done in January and February, and even as late as March. But February is considered to be the best month.

Ordinarily the scions for best root grafting are from six to seven inches long, but they may be made shorter if necessary. On the large end of the scion, make a sloping cut an inch or an inch and a half long, as shown in Figs. 2 and 3. Use a sharp knife and make the cut smooth and uniform. On the surface of the sloping cut, from one-fourth to one-third of the way from the end, make a slit or tongue by a downward cut. The tongue should be an inch or more in depth, partially following the grain of the wood, and partially across the grain, so that the twig does not split. Professional propagators form the sloping cuts, make the tongues and then cut off the

* For methods of growing seedling stocks see article on *Growing Seedlings* P. 119.

scions of the desired length. Next take one of the long seedling roots, and follow the same process of making a sloping cut and a tongue. Begin at the crown (the part of the root

which was just at the surface of the ground), and make the cut so that all of the root and one-half inch or so of the top are used. The operator should learn to be very economical of the seed-



Fig. 1. Long and Short Scion Wood. On the left are twigs just long enough to make one scion each, as will nearly always be the case where wood is taken from old trees that make only a slight growth each season. By the side of these is some long scion wood. The next figure shows how the twigs are cut into scions proper, the short ones making one and the long ones three cuts.

ling roots, and make them go as far as possible. On the other hand, it will not do to leave too much of the part that grew above ground on the root or stock, as the buds would be very likely to grow, thus keeping the scion from forming a tree. In this case, the tree that was formed would be a seedling. In making the sloping cut upon the root or stock, care should be taken to see that it and also the tongue are as near like the slope and tongue on the scion as it is possible to make them. Particularly is it necessary that the slit for the tongue be started at exactly the same distance from the end on both scion and root. The root is now cut off about three inches long and the process repeated until the entire seedling root has been used. If the seedlings made a good growth and the soil was porous enough to let them go down properly, each root will usually make about three pieces. Consult Figs. 2 and 3.

Join the root and scion by placing the two sloping surfaces together and causing the tongues to interlock. Just here the main thing to be observed is to watch one side and see that the bark line of the scion comes exactly into contact with the bark line of the root. This is highly important, for here is where the two are to grow together. The scion and root may not be of the same thickness, in fact seldom are, but this makes no difference if the above instructions are followed. (See Fig. 2.) If the tongues of both scion and stock are of the same length and were started at about the same distance from the end of each piece they will exactly fit. If one of the slits has been started too low down on the face of the sloping cut, this will be shown when the two pieces are fitted together. For example, suppose the tongue was started too low down on the stock, but at the right point on the scion. When the two are put together it will be found that the sloping part of the stock will overlap on the scion far beyond the cut surface where it is intended it should fit neatly. This is very bad, as a wound will result, and such a wound cannot heal. To grow together, the two cut surfaces must be in intimate contact so that their

cambium layers on at least one side will touch. If a cut surface is in contact with the outside of a bark surface, as in the example cited above, it is easy to see that the parts cannot unite. An open wound under ground is as bad as a wounded place above ground, for both invite disease organisms. See right hand side of Fig. 2.

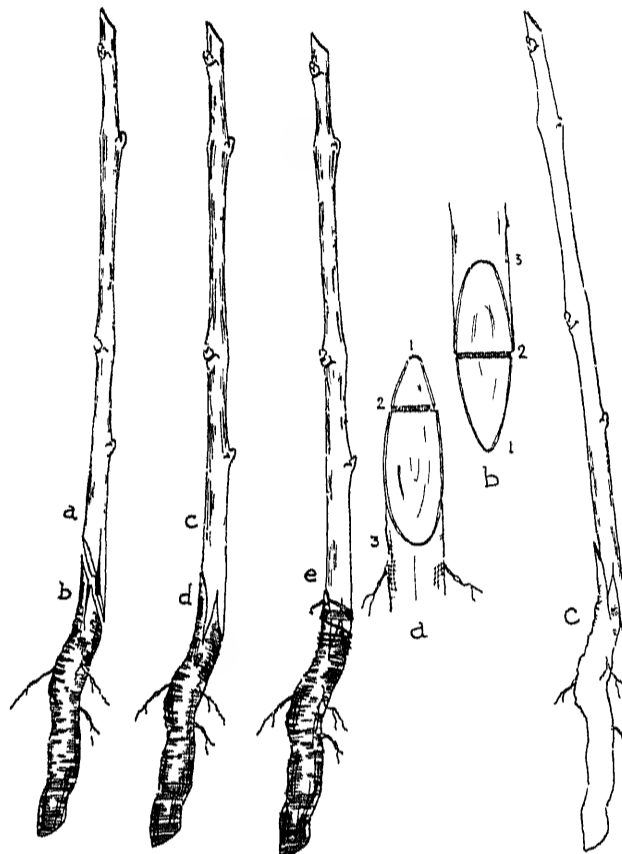

Fig. 2. Propagating Apples by Piece Root Grafting. In the first on the left *a* represents the scion and *b* the root or stock. Note how tongue is cut in each. In the next picture *c* and *d* shows the scion and stock properly fitted together, and *e* illustrates how they are tied with No. 19 cotton knitting thread. Not necessary to wax or even use waxed thread. The remainder of the picture—the three figures on the right, show what happens when the tongues on scion and stock are not made alike. In *a* the tongue is about right, but in *b* it is started entirely too far from the end to match. When made this way and fitted together the pieces overlap and form a very bad union as shown in *c*.

After uniting the scion and stock it will be necessary to wrap the point of union with No. 18 or 20 cotton knitting thread. Holding the graft in the left hand with the root part forward, the thread is laid upon the wood near the end of the cut, wound two or three times around at this place, at the same time pressing the parts together tightly with thumb and finger. Next work the thread up to the other end of the cut by winding it two or three times around the graft during the distance, then two or three

times around the other end of the cut, as in the beginning, and fasten the end, not by tying, but by drawing it down into the cut and by a sharp jerk, breaking it off. This completes the process. The finished graft should be from seven to nine inches long. (Fig. 2.) Some people prefer to dip the ball of wrapping thread in hot grafting wax before using. If this is done it is not necessary to fasten the end of the thread after wrap-

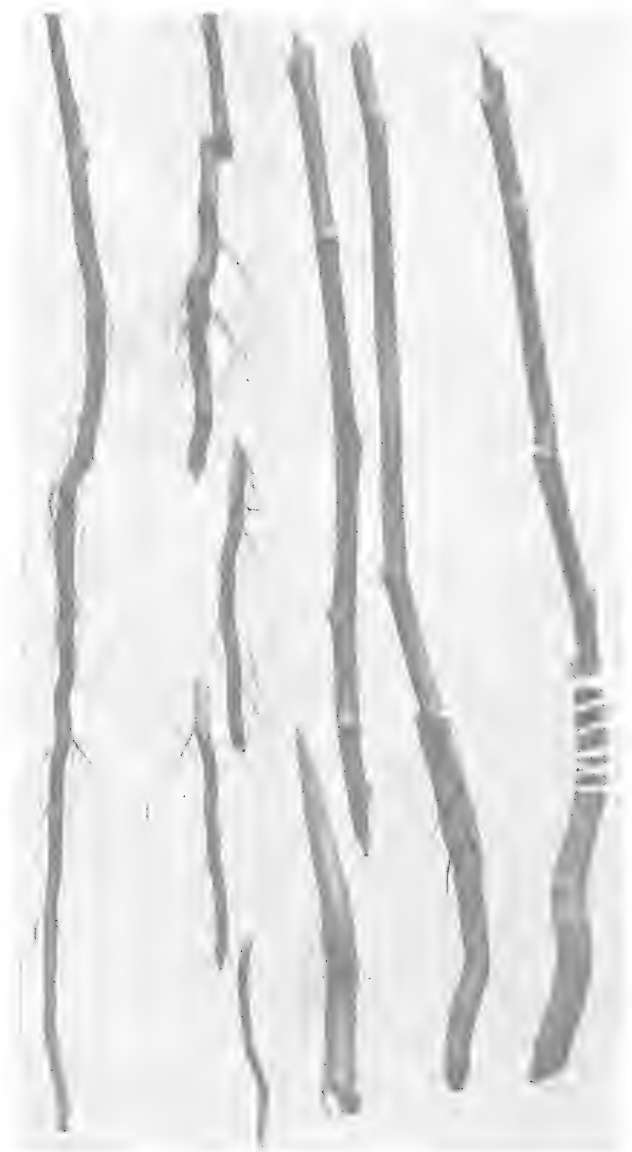

Fig. 3. Apple Grafts. At *a* are shown a good No. 1 apple seedling, whole, and the same cut into three pieces for piece root grafting. At *b* is shown the complete process of making apple grafts.

ping, as the wax will hold it in place. The old way was to thoroughly wax over the point of union after being wrapped with a string. Some also went so far as to wrap with a piece of waxed cloth. But these precautions are not considered to be necessary.

Whole-root grafts are widely advertised. This is a trade name for grafts that have been made by using branching roots

four to six inches long, the scion being grafted on at the crown or part of the seedling root that grew just at the top of the ground. Seedlings that have not formed long tap roots may be economically employed in whole-root grafting. It is not practical, and also is unnecessary to use entirely whole roots, where the latter are very long, in root grafting. In the first place it would scarcely be possible to dig the seedling without destroying a portion of the tap root, and even if this could be accomplished, it would not be feasible to plant such grafts after they were made as they would be two feet or more in length. In many instances there is no doubt but that grafts upon moderately long roots will make better trees than where very short pieces are used. However, very much depends upon the character of the soil and the season in which grafts are grown. With proper handling good trees may be grown with short pieces of root for stock. Owing to cheapness as well as ease in handling, the writer prefers a scion six or seven inches long and a section of root about three inches long. (Figs. 2 and 3.)

In wrapping apple grafts only just enough thread should be used to hold the parts firmly together until planted. It is a mistake to wrap with thread that is too strong, or to use too much of the right kind of string, as such binding material will not decay quickly enough. If the thread does not decay when growth begins after being planted, the tree at the point of union will be girdled or ligatured, thus creating a wound which is a menace to the health of the tree. This is the objection to using waxed thread, as the wax may prevent its decaying at the proper time.

Pack the grafts in bundles of 50 to 100 each and store in green sawdust, where they are to be kept until planting time. While in storage the cut surfaces which have been joined together will actually begin to heal over and partially begin to unite, and on this account the grafts should not be disturbed until they are taken out for planting. Keep the boxes of grafts in a cellar or mod-

erately cool room. They should not be permitted to freeze, and neither must they be allowed to dry out. Examine frequently and sprinkle the sawdust a few times if necessary to keep moist. If the room is warm and the sawdust is kept moist, the grafts will certainly begin to grow at least a month before they can be planted, which will injure them very greatly.

Planting

As soon as the ground will do to work in the spring select a place where the soil is moderately rich, but not extremely so, on which to plant the grafts. Plow the land deeply, and otherwise prepare as for a garden spot. The rows should be perfectly straight in order to facilitate close cultivation with the horse cultivator. Use a line or wire for getting the rows straight. The rows should be four feet apart. The planting may be done by either of two methods. Where a large number of grafts are to be planted a

furrow is opened with a turning plow. The grafts are then stood up along the vertical side and the earth thrown against them with a plow or by hand. Where only a few grafts are to be planted the other method is employed. This consists of making holes about eight inches deep with a wooden pole properly sharpened for the purpose. A long, round bar of iron is sometimes used, but is rather too heavy for convenience. In making the holes the pole should be carefully withdrawn from the ground with many side movements, so that the soil will not fall in.

Plant the grafts deeply. After placing them in the holes or in the furrow there should be only one or two of the buds of the scion left above ground. This makes it necessary that the ground should have been plowed deeply. The most important operation of all in planting is to be certain to press the soil up closely against the roots of the grafts.

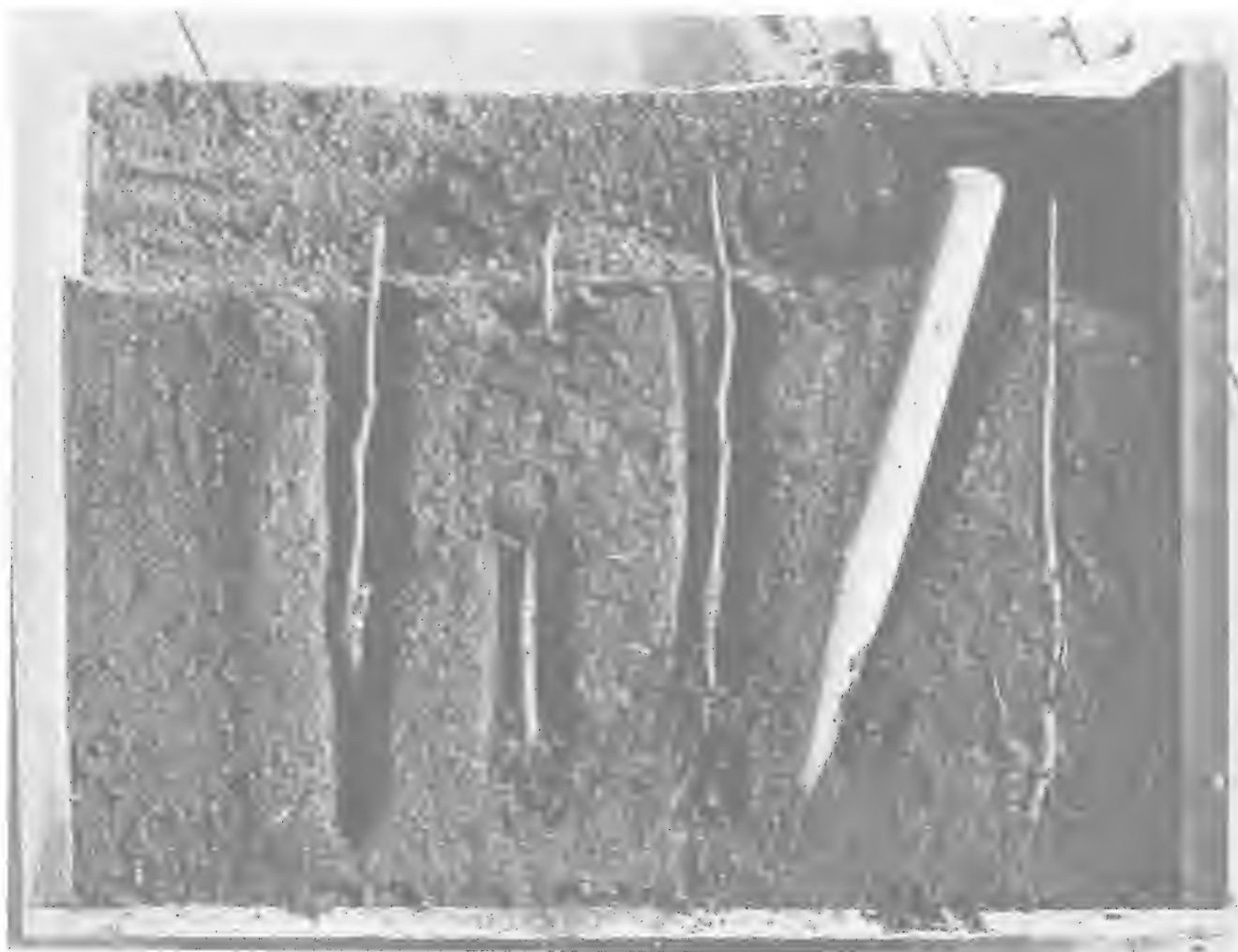

Fig. 4. Planting Apple Grafts. The soil must be pressed tightly against all parts underground. Use a dibber for this purpose as shown in the illustration. The second graft from the left hand side is improperly planted, as there is a large air space at the bottom. The last one on the right is correctly planted—in contact with the soil throughout.

Where grafts are planted in holes and not in a furrow, the soil is best pressed up against the lower part by means of a "dibber." This dibber may be made by sharpening a piece of hoe handle to a long point and attaching to the top of the handle a cross piece for convenience in handling. An ideal dibber is made by using the end of an old spade handle containing the hand piece, together with eight inches or so of the handle, properly sharpened to a point. See Fig. 4 for a plain dibber without special hand piece. The dibber is forced down in the ground by the side of the graft and the soil pressed up tightly against both root and scion from bottom to top. Fig. 4 shows how planting is done.

The grafts cannot grow if air spaces are left around the roots. Here is where more people fail than at any other point. Large growers of young apple trees are disposed to plant most of their grafts

in furrows for the reason that it is next to impossible to get workmen who will do the work of planting properly by the other method. Give the little trees good culture, including two or three hoeings during the summer, and with a fair season they will make a vigorous growth, and attain a height of from two to three feet. In rich soils they will grow even higher. If trees are to be left until they are two years old before transplanting, it will be necessary to go through the nursery early the following spring before growth begins and carefully trim off all branches that may have formed up to a height of 24 inches.

The trees may be set in the orchard after one season's growth, particularly if they have attained a height of three to four feet. If the soil has been fertile and cultivation good they will occasionally grow five feet the first season. A one-year-old tree, three to four feet in height,

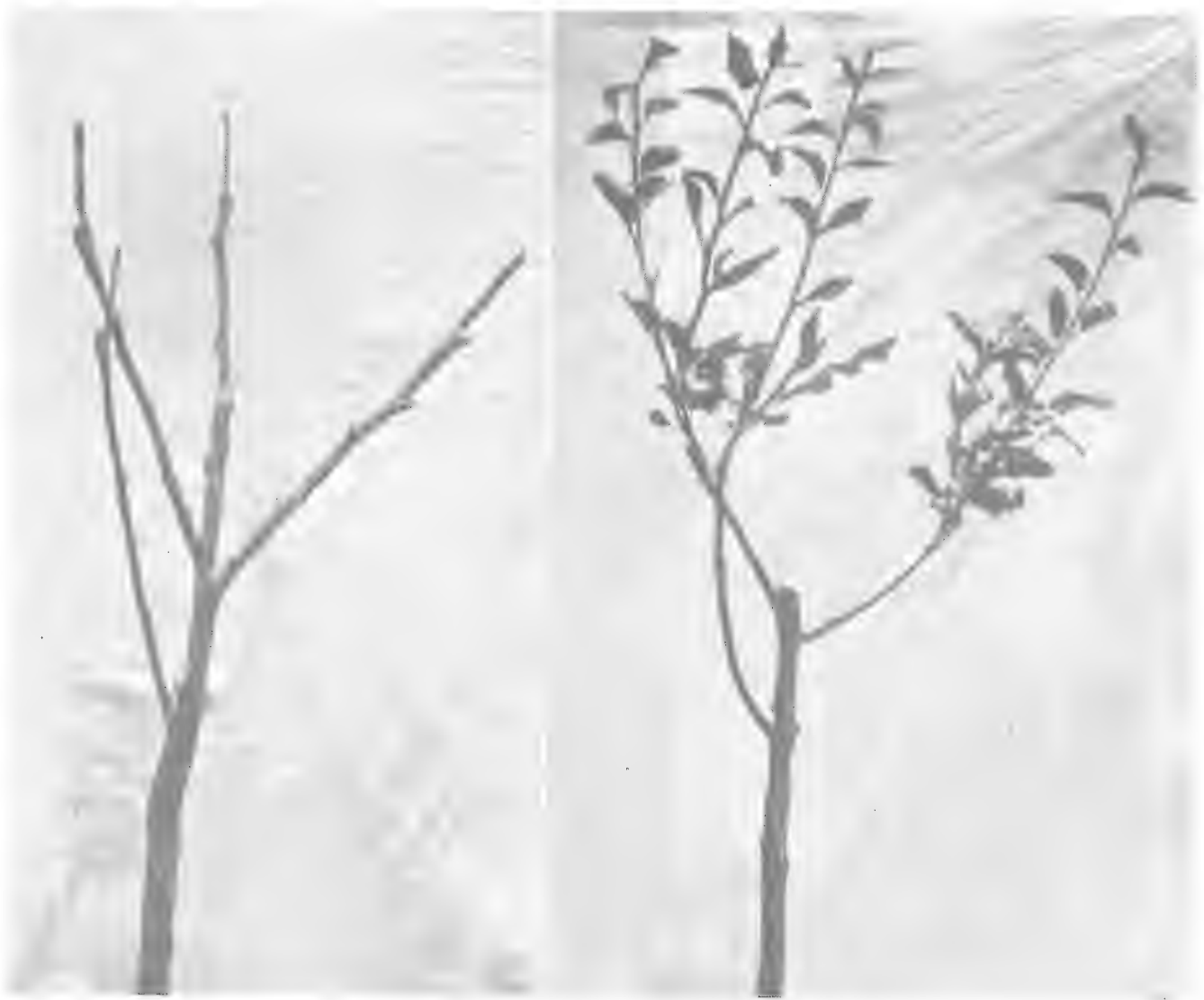

Fig. 5. Young Apple Tree Top Worked by Means of the Whip Graft. The picture on the right shows the pruning received two months after grafting.

would be ideal for planting. In the past, particularly in the Middle West, it has been customary to allow the trees to stand two years in the nursery before transplanting to the orchard. However, there is now a growing sentiment in favor of planting one-year trees, as they can be grown at less cost, are more easily handled, and more economically planted. Trees may be transplanted to the orchard in the fall if there has been rain enough to make the ground moist. South of the latitude of St. Louis or Kansas City, in the Middle West, fall planting is very desirable if the ground is in proper condition. The majority of planting is done in the spring, which is usually the most satisfactory, especially in the North. If it is known that other work will be pressing in the spring, so that the work of planting apple trees is likely to be hurried or otherwise improperly done, then they should be planted in the fall

when more attention can be given to the work.

The whip or tongue graft is sometimes employed for top working very young trees in the orchard, particularly those that are only one year old. For trees of this age this method is regarded as being better than the cleft graft. Tie securely and cover with wax.

Cleft Grafting

While the whip or tongue graft described above is the method in most general use among nurserymen for the propagation of apple trees, there is another form known as cleft grafting that is used very extensively by farmers and others who have only a few trees. A knowledge of cleft grafting is especially useful where one has an apple tree that has reached bearing age and is found to be unsatisfactory, either in the kind or quantity of its fruit. The tree may be

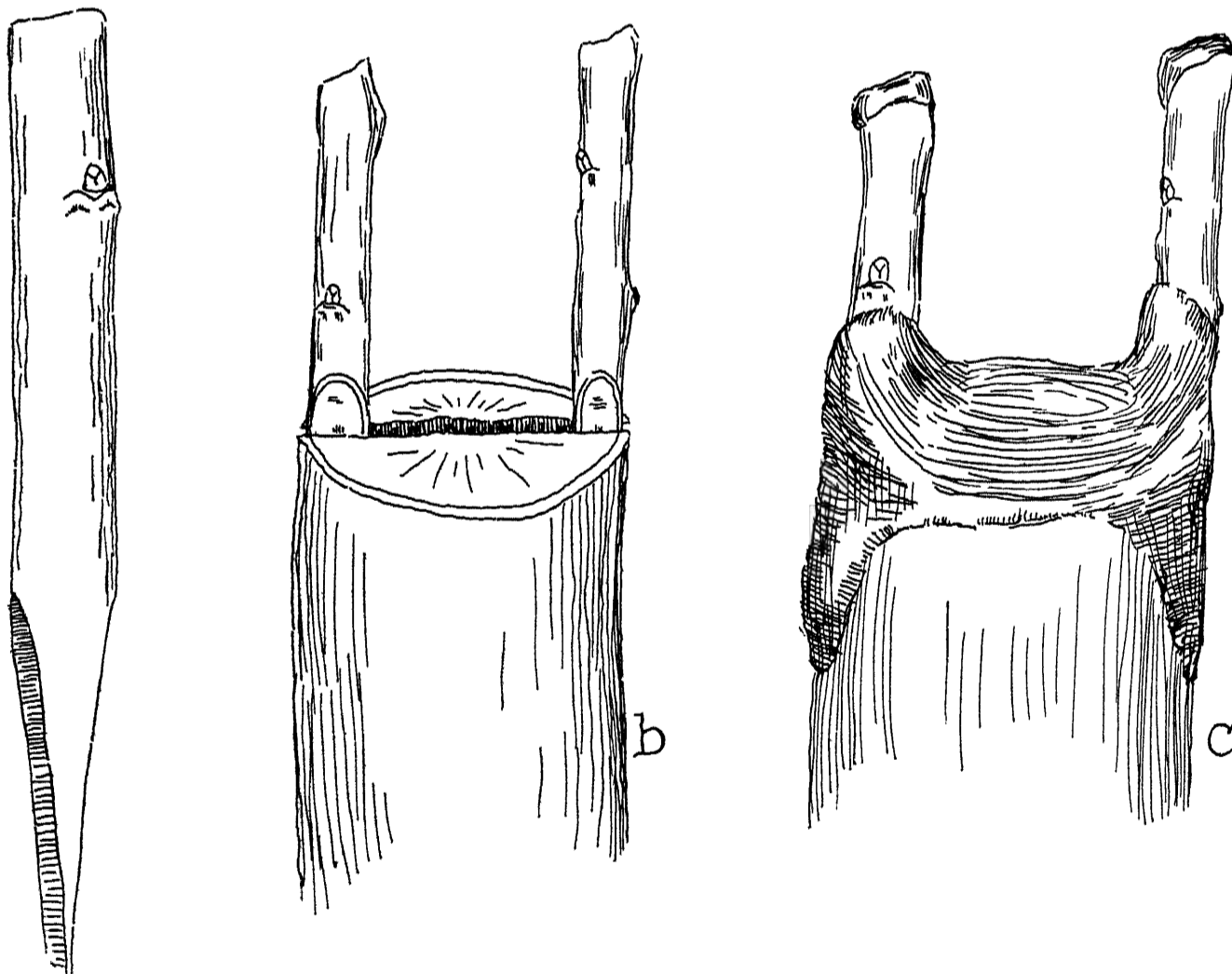

Fig. 6. The Cleft Graft. The short scion (about four inches long) whittled to a wedge shape, is shown at *a*. The middle figure, *b*, shows how the stump or branch is sawed off and split, and how the two scions are inserted. Note that the inner part of the bark of the scion is exactly in contact with the inner bark of the stock. The last figure, *c*, illustrates how all cut surfaces must be thoroughly covered with hot grafting wax.

cut down if not too old, or regardless of age (if large enough), its branches may be sawed off and the desired variety of apple inserted upon the stump or stumps. More people will have occasion to use the cleft graft than the first method described.

Cleft grafting is sometimes employed on other trees besides the apple. This method is also sometimes called top grafting. As many varieties as there are branches to work them upon may be top grafted upon a single tree. In fact, there is no reason why summer, fall and winter apples may not be grown on the same branch or adjacent branches. It is a matter of great curiosity to see apples of different colors and sizes growing upon the same tree, but such a mixture would be of little practical value, as there would not be enough of any one kind of fruit to amount to much. New varieties may be hurried into bearing by being worked upon the branches of an old tree. Weeping forms of trees like the mulberry, ash, elm and others, are often top-worked upon upright growers by cleft grafting.

It will be necessary to collect the scions for cleft grafting early in the winter before freezing weather, and store them in the manner described under the discussion of whip grafting. The work of cleft grafting is done in late winter or early spring. Top grafting of apple trees is more successful if done before growth starts, but where only a few trees are to be worked the operation may be delayed until after the leaf buds are just beginning to open. Regardless of when the grafting is done, the scions must be perfectly dormant. To do the work saw off the branch if as much as an inch in diameter or even the body of the tree, if it is not more than three or four inches thick, and split the stump down the center towards one side with a knife or hatchet. The scion, which is the same kind of wood described for other scions, should be only four or five inches long. The lower end is whittled on both sides to a wedge shape. Where many trees are top worked, the safest way to set the scions is to lean them inward (or outward) so that the growing layer of both scion and stock are sure to be in

contact at the point where they cross. In making the wedge the slopes must be long and uniform—care being taken to whittle the same amount of wood from each side. Sometimes the branch or trunk, if as much as three or four inches in diameter, is split through the center in two directions, thus making room for four scions. Instead of splitting the trunk or branch through the center many people now prefer to make the cleft toward one side so that the split part involves only the outer part of the sap wood. Such a method would not cause such a large wound, and on this account it is now preferred by many good propagators.

As explained, the slope on the scion must be long and uniform. Pry open the cleft in the trunk or branch to be grafted and carefully insert the scion so the bark of one side will be exactly in contact with the inner part of the growing part of the bark of the stock on that side. This is extremely important, for here is the place where they are to grow together, and they cannot do so unless the inner bark of one piece is exactly in line with the inner bark of the other. If the old branch or trunk of the tree is large enough, that is, thick enough, it is advisable to use two scions, one at either side of the cleft, as this will double the chances of success. The same principle is followed where four scions are used.

If the grafted stump be as much as three inches thick a wedge for the purpose should be made of pine, or almost any other wood, and driven down in the center of the cleft, just far enough to relieve the great pressure which would otherwise be exerted on the scions, but yet not far enough to cause them to be loose. After being driven down to the proper point the wedge may be broken off even with the top of the stump.

When the scions and wedge are in place it will be necessary to cover all cuts and cut surfaces with hot grafting wax. The wax may be melted in a tin pan at the house and carried to the orchard if not too far away. It is best to prepare a small wooden paddle with which to dip up the molten wax and spread it over

and around the scions in such a manner as to entirely exclude the air, and thus keep them from drying out until they unite with the old wood. This wax should never be disturbed afterward, as it will not injure the tree. If more than one scion grows, by all means cut them off. If two scions are allowed to stand, a forked tree will be formed, which is always to be avoided.

Old apple trees may be top worked to other varieties and entirely renewed by means of cleft grafting. If trees are 10 to 20 years old, all of the branches cannot be cut off and grafted at once. Perhaps four-fifths of the branches may be top worked to the desired variety in one season, and the remainder the next sea-

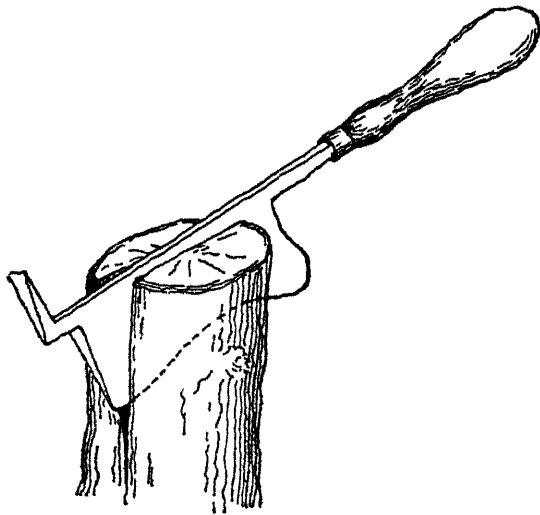

Fig. 7. A Handy Tool for Use in Splitting Limbs for Cleft Grafts. The wedge shaped point is used for holding the cleft apart while inserting the grafts.

son. In old trees the growth which results from the newly inserted grafts seems to require some protection from sun and wind. A few old branches are left for this purpose. Furthermore, the old branches are necessary, as the tree will be in need of more foliage than the grafts could supply in early summer to carry on the necessary vital activities which it is the duty of leaves to perform. The chief duty of such leaves, in fact, is to feed the roots.

In top working vigorous growing trees of from three to five years' growth in the orchard, the trunk is often cut off a foot or so from the ground and cleft grafted. The one scion that is permitted to grow pushes upward so rapidly as a result of the pressure of the large root system of the tree, that it is in very great

danger of being blown off during the summer. In such cases it is nearly always necessary to drive down a stake to which the little top of the tree may be bound for greater security.

Another form of cleft grafting which is coming into general use in the West and Northwest is somewhat similar to the cleft graft that has been described, except that the stock is not split at all. Instead, a sharp saw is used to cut a notch upon one side of the several points around the edge of the stump. By sawing straight into the wood the notch will be sufficiently wide to admit the scion if the saw teeth have a wide set.

In preparing the scion this will have to be whittled to a somewhat different shape, but in the main the same principles will have to be observed as with the other method. Be sure that it fits the notch. Lean the scion inward and force down so that it reaches below the notch. This will make it certain that the bark lines cross. Finally cover all cut surfaces with hot grafting wax.

In all forms of cleft graftage, but particularly those which employ the splitting of the old wood, it should be remembered that the growth which heals the wound will take place from the scion and gradually spread through the end of the branch or trunk that has been cut off. The old wood is absolutely incapable of growth, and hence is liable to become infected with disease germs unless kept protected until the new wood can cover it over completely. If there is a break in the wax the sap, which is under strong pressure from the roots, will ooze out and become sour, because it has been attacked by certain germs which set up a fermentation. These same germs, and also others, may find their way beneath the wax and the central part of the tree thus becomes affected, and even though the wound may eventually heal, the tree will decay from the interior. This is very likely to cause a hollow tree, which might break down under the first heavy load of fruit.

Grafting Wax

There are more than a dozen recipes or formulas for making grafting wax,

but all of them are essentially the same. The formula which has been used for many years by the Horticultural Department of the University of Missouri and found to be very satisfactory, is as follows

Common resin	7 lbs.
Beeswax	2 lbs
Beef tallow	1 lb

If this much is not desired divide each of the above items by two, three or four, as may be needed. Dissolve all of the ingredients in a vessel over a fire, stirring thoroughly. When they are well mixed, pour such of the mass as can be handled at one time into a tub of water, where it will quickly cool. Grease the hands with tallow and gradually work the mass together in the water. When cool enough to stick together, remove from the water and pull like taffy candy until it becomes too stiff to work. The process should be kept up for at least 15 minutes, or until the mass has changed color, much in the same manner as molasses candy. Roll into balls four or five inches in diameter and store away until needed. It will keep indefinitely. Instead of the beeswax, some people prefer to use paraffin. A pint of raw linseed oil is sometimes used instead of the tallow that was recommended.

Budding

Apples may be propagated readily by budding at whatever time the bark peels best. This date will vary from June to September, depending upon latitude and weather conditions. The work is usually done during August or the first week in September. The buds must be inserted in the wood that grew the same season that budding is done. If the trees are grown from the seed they may be too small for budding the first season. In this event they should be cut back to the ground the next spring, and the new sprouts budded towards the close of the season. The stock is usually transplanted before budding. The branches of old trees are sometimes cut off and the new growth that comes out may be budded at the proper season. Similarly where the trunks of trees are cut off for the same

purpose or which have been top grafted, but the scions did not grow, sprouts will arise, which may be budded.

Relatively speaking, apple trees are not budded to any great extent, as it is more convenient to propagate them by means of the root graft. However, some nurseries make a specialty of budded trees. It has been claimed that budded trees are superior to those grown from root grafts, the argument being that there is no wound below ground, and hence the organisms which often attack the roots of apple trees will cause no injury. This is undoubtedly partially true, although it is found that budded trees are attacked by the diseases known as "crown gall," as well as those that have been grafted. As a rule budded trees make a better root system than piece root grafts and therein lies their superiority if they possess any. (Detailed statement of how budding is done will be found under the heading of *Peaches*.)

Dwarf Apples

Any of the common varieties of apples may be grown as dwarfs, provided they are worked upon the Paradise apple, which is a natural dwarf.

Doucin stock produces what is known as half-dwarf apples. Some varieties of apples are not adapted to being grown as dwarfs to any great extent in this country. In general, the very vigorous growing varieties are not adapted to being dwarfed. The Ben Davis, it is known, will not dwarf successfully.

Paradise and Doucin stock must be imported from France, Holland or Germany, as they are rarely propagated in this country. Since there is now a small demand for dwarf apple trees, the larger nurseries have begun to carry them in stock. The very large nursery firms of the country generally are able to supply small orders for Paradise or Doucin stock for grafting purposes. They are more expensive than the common stock, as the usual method of propagation is to mound up the earth around the little trees and permit the numerous branches to take root. Then they are cut away and sold. On this account (being rooted branches),

they are not adapted to being used as stock for piece root grafting, but are generally set out and allowed to grow one season and then top worked by one of the methods described.

Dwarf apple trees come into bearing much earlier than others, but do not live nearly so long. Dwarf apples, particularly varieties adapted to dwarfing, attain a height of six or seven feet, and hence a large number may be grown on an acre of ground. Dwarfs are sometimes grown in pots. In the orchard they may be planted as close as eight or ten feet apart each way.

W. L. HOWARD,
Columbia, Mo.

Root Grafting Piece-Root Experiments

Probably no topic connected with apple growing has received more discussion than the methods of grafting, the most diverse opinions being held by nurserymen and apple growers. The Kansas station has recently reported experiments in which some important points in regard to root grafting apples were brought out. The object of the work was to determine the relative positions of the graft on the stock. The tests were carried through a number of years, and in all several thousand grafts were made. The stocks used were all No. 1 seedlings, most of which were regraded to get a uniform lot. The scions were also as uniform as possible.

In the first experiment six-inch Ben Davis scions were grafted on different parts of roots. The tops of seedlings were cut off below the crown and the roots cut into three pieces. One hundred grafts were made with the upper parts of the roots, 100 with the middle parts, and 100 with the lower parts or tips of the roots. About 80 per cent of the grafts made with the upper and middle parts of the roots grew, and at one and two years old there was little difference between the trees grown from them. Of the grafts made with the root tips only 60 per cent grew. The first season the trees of this lot averaged one-third less in height than the other lots and were more slender and weak. The second year

the difference was less marked. The same year that the above experiment was begun 100 Ben Davis scions two feet long were grafted on the upper parts of roots cut below the crown. At two years old these trees were about one-half larger and stronger than the trees from six-inch scions on similar stocks. Many of the tops were so heavy as to necessitate summer pruning.

In 1893 more extensive experiments were made. Winesap, Missouri Pippin, Ben Davis, and Maiden Blush apples were used in each series of grafts made. Three lengths of scions, 6, 12 and 24 inches, were used. With each kind of scion four lengths of stocks were used, namely, piece roots, $1\frac{1}{4}$, $2\frac{1}{2}$ and 5 inches long, and whole roots. For all piece-root grafts the upper parts of roots were used. In all cases except where $1\frac{1}{4}$ -inch stocks were used, one-half of the grafts were made one inch above the crown and the other half below the crown. Besides the above a number of grafts were made on $2\frac{1}{2}$ -inch piece roots of small size. In all 9,200 grafts were made. The grafts were set in nursery rows, with the place of union of stock and scion in all cases about three inches below the surface of the soil. The percentage of loss was great, owing to the very unfavorable spring and to the grafts having been stored in a cellar which was too warm. The loss with the whole root grafts was least, and increased as the length of the root diminished. About 82 per cent of the whole-root grafts were living at the end of the first year, as against only about 49 per cent of the 5-inch, 17 per cent of the $2\frac{1}{2}$ -inch, 11 per cent of the small $2\frac{1}{2}$ -inch, and 6 per cent of the $1\frac{1}{4}$ -inch piece-root grafts. From measurements made at the end of the third season it was shown that the greatest growth was made in trees grafted on the longest stocks and that the growth declined gradually, though slightly, with the shorter stocks, being about 11 per cent greater with the whole root than with the $1\frac{1}{4}$ -inch piece-root grafts. The trees also showed a tendency to make the best growth from the longest scions, the growth being 11 per cent greater with

the 24-inch scions than with the 6-inch ones. There was no constant difference in growth between the trees grafted above the crown and those grafted below it.

In 1894 the above experiment was repeated in part with Winesap, Ben Davis, and Missouri Pippin apples, using 6, 12, and 24-inch scions on whole roots and 5-inch piece-root stocks grafted above and below the crown. After two years' growth there was no constant difference between the trees grafted above the crown and those grafted below, either as regards height or diameter. The length of the stocks and scions had a marked influence on the growth, the difference in favor of the long stocks and long scions being practically constant in all cases. The height of 2-year-old trees grafted on whole roots average 21 per cent greater than on 5-inch stocks and the diameter over 3 per cent greater. Trees from 24-inch scions averaged 10 per cent higher than from 12-inch scions, and 20 per cent higher than those from 6-inch scions. Their diameters were 27 per cent greater than the trees from 12-inch scions and 34 per cent greater than those from 6-inch scions. These differences were not nearly so marked after the trees had made three years' growth, the diameter of the trees from 24-inch scions at that time averaging only 6 per cent greater than those from the 12-inch scions and only 7 per cent greater than those from the 6-inch scions as against 27 per cent and 34 per cent, respectively, after two years' growth.

In 1895 grafts were made with 12 and 6-inch scions on whole roots, 5-inch roots, and 2½-inch roots, grafted above and below the crown. In addition a stock grafted above the crown, with roots cut eight inches long, was tested. After two years' growth no constant differences were shown in favor of either length or style of stock or of grafting either above or below the crown. The trees from 12-inch scions were invariably greater in height and diameter than those from 6-inch scions.

An experiment in root grafting was made by F. Wellhouse, president of the

Kansas Horticultural Society. About 400 trees each of Winesap, Ben Davis, and Missouri Pippin apples, grafted on whole-root stocks, were set in the orchard together with trees grafted on two-inch piece-root stocks. During 19 years no difference in growth, vigor, or fruitfulness was observed between them, except that for the first six or eight years the whole-root trees threw up from their roots more water sprouts than did the piece-root trees.

These tests show that there are fairly uniform differences in the first few years' growth of trees in favor of the longer scions and stocks, but that by the end of the third year's growth the differences largely disappear, and that there is no constant difference between trees grafted above and those grafted below the crown.

Besides the observations on the height and diameter of trees, the Kansas station has also reported a study of the root development of grafted trees. It was found that the main root growth of the first year from all lengths of stock was made at or just below the union of the stock and scion, and that the growth at this point became more pronounced in the second and third years. The growth from the lower portion of the stock was very slight during the first year, and became of even less importance during the second and third years; the growth from the lower part of the stock was greatest in case of the shorter piece roots and least in case of the whole roots. With grafts that were buried deeply a new system of side roots formed at about the

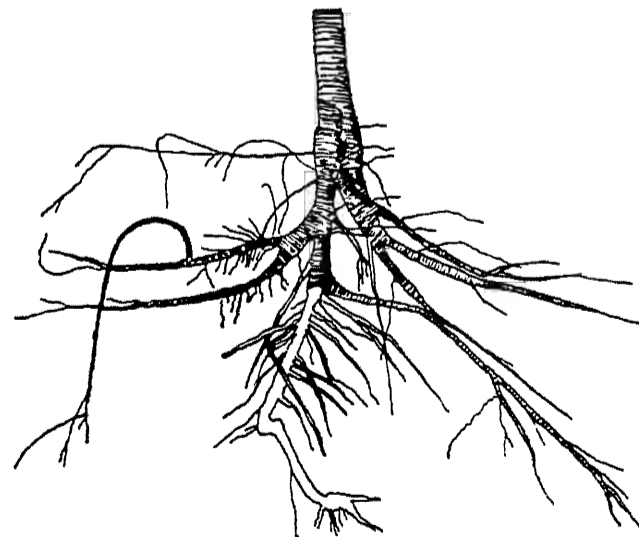

Fig. 1. Whole Root Graft of Apple.

usual depth below the surface of the soil, to the more or less complete dwarfing of the lower and earlier root system. This is shown in Fig. 1, which represents the root development from a whole-root graft, which was buried about five inches below the surface of the soil. The whitened portion of the root is the original stock. The other roots formed from the scion.

All these experiments go to show that the use of long scions and stocks may be of some little advantage to nurserymen in inducing a better growth of trees during the first two or three years. The long scions and stocks are, however, considerably more expensive than the shorter ones. Planting whole-root grafts is much more laborious than planting short piece-root grafts. In reporting these experiments the authors say that the difference in growth in favor of the longer scions and stocks is probably not sufficient to repay the extra expense made necessary by their use.

For the fruit grower, at least in the locality of the Kansas Station, the longer stocks appear to have no advantage over the shorter ones, since trees produced from them make no greater growth than trees from the shorter stocks except in the first few years. The fact that the greater part of the root growth is made from the upper part of the stocks is evidence that the long stocks serve very little purpose. The production of roots from the scion, as occurred when short piece roots were used, is in many cases a direct advantage, since seedling stocks are very variable in hardiness and vigor of growth. Under the conditions at the Kansas station piece roots from two to five inches long are thought to give the best results, all things considered.

U. S. Department of Agriculture, Farmers' Bulletin No. 79.

Apple on Pear and Pear on Apple

The experience of nurserymen generally seems to be that apple scions on pear roots result in sickly, short-lived trees, although it is possible to secure a good union and for a time the tree seems to do well. When the tree is set very deep so that the apple may put out new

roots of its own a vigorous growth may be secured, but in this case the pear root only serves the temporary purpose of keeping the apple growing long enough to enable it to secure roots of its own. Pear roots are more expensive than apple roots so that it is extremely unlikely that the practice will be followed to any extent, even though it were moderately successful.

Reversing the process and grafting pear upon apple roots results in dwarfing the pear. Here again it is possible to secure a good union but with the dwarfing effect noted. The tree thus produced is more prolific but is short-lived. Planted deeply the pear scion will root itself the same as the apple but with greater difficulty, according to some reports.

Pears are grafted upon quince for the purpose of dwarfing them and apples may be grafted into "Paradise" stock, a low form of apple, which results in dwarfing the apple.

Ed.

Heading Trees in the Nursery

* It is understood that the first pruning largely determines the height of the head of the tree. The question has arisen, "Why not head the tree before it leaves the nursery, instead of waiting until the year of planting?" The system does have advantages some of which I shall set forth. One is that it brings returns in the bearing fruit one to two years before the ordinary trees begin to bear. We have at this time in our nursery 18-months'-old nursery stock headed in the nursery with fruit on the trees at this time.

Mr. George Davenport, of Mabton, Wash., fruit inspector, found many fruit spurs on an eight-months'-old tree which had been headed in the nursery. We have been experimenting on heading, pruning and growing trees in the nursery for two years past in an attempt to produce trees, which, when planted in the orchard as fillers will produce apples the next year. We are making our fillers principally from Jonathans, Wageners and Rome

* The "Head" of a tree is the point at which the trunk forks to form the main branches—Ed.



The Figure Shows Two Jonathan Apple Trees, Five Months Old. "The Old" shows the ordinary tree as it is set in the orchard and trimmed; "The New" shows the nursery headed tree set in the orchard ready for trimming.

Beauties. Professor W. S. Thornber, formerly of the Washington State College at Pullman, Wash., stated at the State Horticultural Meeting at Prosser, Wash., 1911, that early bearing does not injure a tree, assuming that the allotted time for which fillers are to occupy the ground is eight years.

Following the above method we have produced a tree that will bear fully 25 per cent more fruit, and bear this fruit from one to two years earlier than trees planted in the ordinary way. Whether it will become extensively practiced as a system for planting the permanent orchard is yet to be demonstrated. We have, however, commercial orchardists who bought these trees last year for fillers and who are placing orders for both permanent trees and fillers to be headed in the nursery according to our

method of growing trees for fillers. It is claimed that this enables the trees to make a better root system as the top growth is checked 30 to 40 days by pruning and in the meantime the root system is growing. After this period the tree instead of growing a five or six-foot whip in length, makes a branched top which becomes a permanent part of the tree, being equal to a two-year-old tree.

We find our way of treating them in the nursery makes a balanced head and root system, and nature has developed a perfect tree, headed near the ground, and it is now past what we call the "dehorning system," as it requires very little pruning from now on.

The commercial tree should be low and spreading and should be made without too much wood cutting which causes black heart. In planting a nursery-headed tree you have the advantage of setting the heavy side to the wind,

while in the ordinary tree you do not know which is going to be the heavy side, and if the orchard is in the care of unskilled labor it is likely to be spoiled by improper pruning.

A. B. CAPPS,
Prosser, Wash.

Pruning the Top

Some growers leave the pruning of the top of the trees till they are set out in the field, but it would seem that the work might be more conveniently done before the trees are set. This would so reduce the bulk that the trees would be more conveniently handled, and would obviate the necessity of walking over the whole orchard to prune the trees after planting. The ultimate shape of the tree depends largely upon how it is pruned when set. With yearling trees the operation is very simple and consists

merely of cutting off the top at a point where it is desired to form the head. With most varieties the head should be started not more than two feet above the graft union, but in some naturally spreading varieties, like Rhode Island Greening, for example, the head would be much better started at a point three feet from the ground. With trees two or more years old the heads, which have been formed in the nursery row, are often too high.* In such cases the entire head should be removed and the trees induced to form new heads. If the heads are in the proper position, the necessary pruning consists simply in cutting out unnecessary branches and in cutting back the remaining three or four branches to within about six or eight inches from the stem.

See article by A. B. Capps, "Heading Trees in Nursery." If Mr. Capps' methods were used it would be unnecessary to prune the top at all.—Ed.

Treatment of Nursery Stock for San Jose Scale

The San Jose Scale. The reputable nurserymen are very careful to keep their stock free from scale, and most of them are provided with a fumigating house for the purpose and fumigate all their trees before they send them to their customers. Notwithstanding these precautions, the introduction of the scale into uninfested sections may usually be attributed to the planting of infested nursery trees. The most careful examination is not sufficient to detect the presence of scale, for the insects often hibernate in small crevices in the bark and under bud scales. Before planting the trees in uninfested sections it is therefore important that they should be either refumigated or dipped. The expense in connection with the fumigation or dipping is very insignificant compared with the cost of spraying the trees a few years later.

Fumigating

Fumigating nursery stock consists in subjecting the trees to the fumes of hydrocyanic acid gas for a period of 30 to 45 minutes. The gas is made by using the following chemicals:

* The terms "high" or "low" heading are relative and of course vary with the circumstances and the nature of the tree.—Ed.

Water	4 fluid ounces
Sulphuric acid (high grade, 66° Baume).....	2 fluid ounces
Potassium Cyanide (98-100 purity)	1 ounce (av.)

This quantity is required for every 100 cubic feet of space. A tight box about six feet long by four feet wide and four feet deep, will answer the purpose. It should be supplied with a tight fitting cover the full size of the top, and adjusted so that it can be opened from a distance. (See Fig. 1.) The box should

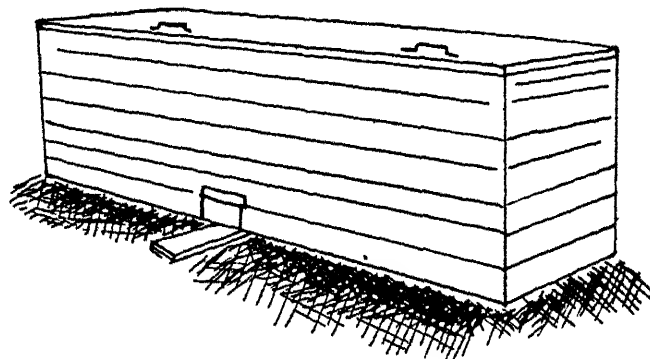

Fig. 1. A Home-made Fumigating Box for the Treatment of Nursery Stock.

also have a small slide door located at the bottom near the center. It is through this door that the chemicals are introduced. The acid and water are mixed together and placed in position, and when everything is in readiness the cyanide is dropped into the liquid and the small door quickly closed. When the time is up the top should be removed by means of a rope through a pulley-block suspended above. *The fumes are extremely poisonous and should not be inhaled.*

The process of *dipping* fruit trees is probably more satisfactory for general use among fruit growers than fumigation. Nurserymen, and others who are familiar with the use of potassium cyanide for this purpose, will probably find fumigation more convenient. While injury may follow either method, if the necessary precautions are not observed, there is less risk with the dipping process. Either the lime-sulphur wash or miscible oil may be used for dipping. The former is somewhat troublesome to prepare, and in view of the small quantity required for this purpose the trouble would be unwarranted. Some of the prepared lime-sulphur solutions on the market have given good re-

sults when diluted with not more than eight parts of water. The miscible oils, of which there are many brands on the market, are well adapted to the dipping of the nursery stock. They should be diluted with about 15 parts of water. The only precaution necessary regarding the use of these oils is to shake up the supply of oil thoroughly before drawing any off and to make sure that it completely mixes with the water. A few drops in a glass of water should produce a milk-like solution, without any free oil on the surface. Miscible oil, on account of its spreading action, is more likely to reach the insects that may be in protected positions.

The only thing necessary in the way of equipment for dipping is a tank deep enough to accommodate the young trees after pruning. A tank four feet deep, if kept well filled with the mixture, will answer the purpose. The trees are simply lowered into the bath, tops first, as far as the roots. They are then immediately withdrawn and the operation repeated. They are not allowed to remain in the liquid longer than is necessary to completely coat their surfaces with the mixture. A limited number of experiments with miscible oil suggests that the roots may also be dipped. Such a procedure is not recommended, however, unless the roots are infested with woolly aphis.

C. D. JARVIS,
Storrs, Conn.

Selecting Stock

After the tree has been successfully grown in the nursery the next step is naturally that of transferring it to its permanent place in the orchard. To the man, however, who must select his stock from some nursery not his own, there are several questions of importance.

Selecting the individual trees to be planted requires some little thought, as oftentimes we lose a whole year by choosing poor and inferior trees. Care should be taken to secure *first class* trees of the proper type for each of the varieties selected and trees that are well grown, vigorous, and free from diseases or blemishes. The ideal tree of most planters is one that is straight and smooth. The tree

may be straight and smooth or it may be crooked and gnarly. All this depends upon the variety. Because a tree is crooked is not a sign that it is a poor specimen. That may be a characteristic of that variety. Some of the best varieties have crooked stems or ugly tops. Many planters think that large size is of itself a great merit in a nursery tree. This is not always true. Vigor and stockiness are more important than large size. Buy first class, shapely, and well grown trees that have abundance of roots, free from such diseases as the crown gall or blackknot. In many states buyers require the nurserymen from whom they buy to give them a guarantee that the trees are free from all injurious insects and diseases. This rule ought to be adopted. While such a guarantee does not absolutely prevent a tree from being infested with insects or diseases it lessens the probabilities of their being so infested.

Place to Buy Trees

(1) "Where can I buy fruit trees?" and, "Do fruit trees from the North, South, East or West do best in this climate?" are questions frequently asked by orchardists. The question of the source of the tree is one which attracts considerable attention and bears some relation to the planter's local conditions, but is one which cannot always be definitely answered. It involves a number of things such as the manner of growing the nursery stock, the distance to be shipped, the way the trees are packed when shipped, and the treatment of the trees when received. Apparently there seems to be no material difference in the growth of the trees on account of their source, if the trees have been well grown, well packed, well taken care of, and well started when they are received. As a rule, however, if all of these conditions be equal the home grown trees or those grown nearest you are to be preferred.

(2) There are several reasons why it is usually advisable to patronize local nurserymen. They generally handle the varieties that are best adapted to local conditions. But if the local dealers have not the required varieties in stock, or if

their trees are not of the desired shape, it would be better to order from a distant nursery rather than to accept undesirable stock. By dealing with a local nurseryman the buyer can visit the nursery and personally select his stock, and at the same time reduce the risk of introducing injurious insects and diseases that are not common to the neighborhood. Again, home nurserymen are more likely to supply the kind of stock ordered and to correctly label their goods, for if they persistently misrepresent they cannot long continue in business. The agent for a distant firm, on the other hand, can constantly change his field of operation.

(3) Still further by securing trees at the nearby nursery all danger from damage by long transit and the injurious effects of sunshine and frosts are avoided; besides, if the farmer makes his purchase direct from the nurseryman, he will save the expense of the middleman or agent, and is less liable to the mistakes and injury that may occur through repeated handling.

To sum up, trees from the nursery should be:

1. First-class stock.
2. Vigorous and stocky with good root systems.
3. Well shaped and low headed.
4. Preferably purchased from local nursery if good stock can be obtained.
5. Correctly named.

-
- (1) Fabian Garcia.
 (2) C. D. Jarvis.
 (3) G. B. Brackett.

Kind of Trees to Buy

Most growers plant two-year-old trees and, other things being equal, they are probably most desirable. It is often difficult, however, to get such trees of the desired shape.

The two-year-old tree has its top formed in the crowded nursery row and therefore does not assume the proper shape. During recent years the difficulty of getting properly shaped trees has been greatly lessened, for the nurserymen are now heading their trees much lower. The low-headed tree is now generally preferred, but with those varieties, like

Rhode Island Greening and Tolman, that are naturally spreading, the head may be started higher, than with varieties like the Yellow Transparent, that are naturally upright growers.

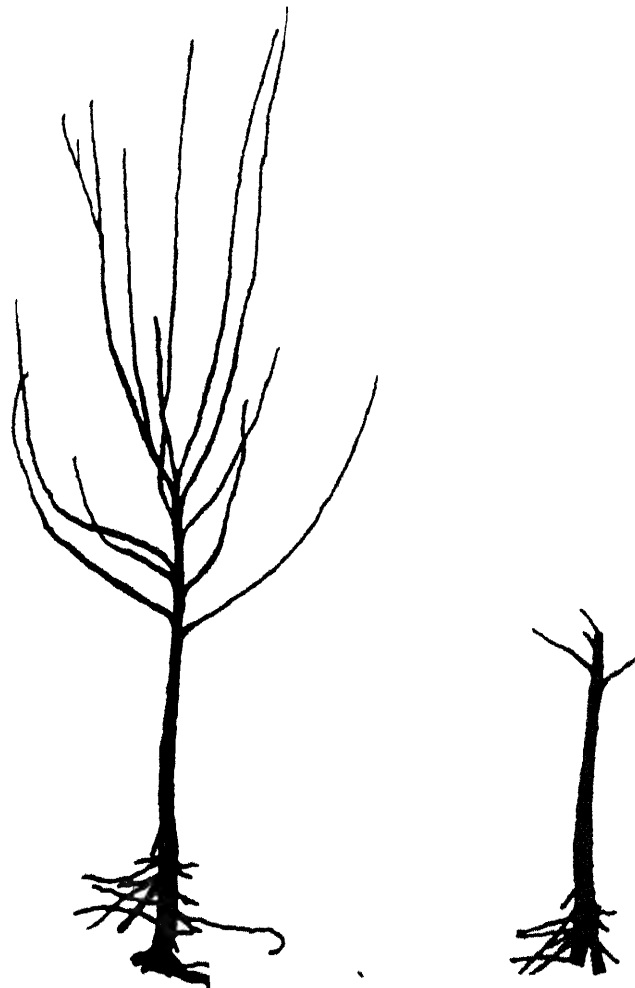

Fig. 1. A Two-year-old Nursery Tree Before and After Pruning. This tree was not headed in enough the first year and it was therefore necessary to remove much of the top. In addition it was headed too high in the beginning.

*If two-year-old trees of the proper shape cannot be obtained it would be better to buy yearlings, which are mere whips, and plant them in a nursery row for a year, giving them more room than they previously occupied. In this way the grower may shape his trees to suit himself. This method is especially applicable to the man who must clear his land before planting, for the reason that there would be no loss of time. With the man who has his ground ready to plant, on the other hand, it would mean a loss of one year. Some recommend the buying of yearling trees and placing them back in the nursery row for two or more years, or the buying of two-year-old trees and putting them back in

* In Northwest one-year-old stock preferred.—Ed.

the nursery row for one or more years before setting them in the orchard. Such a practice affords an opportunity for weeding out the weak and undesirable trees before they reach their permanent location, and permits of the full use of the orchard land for other purposes for

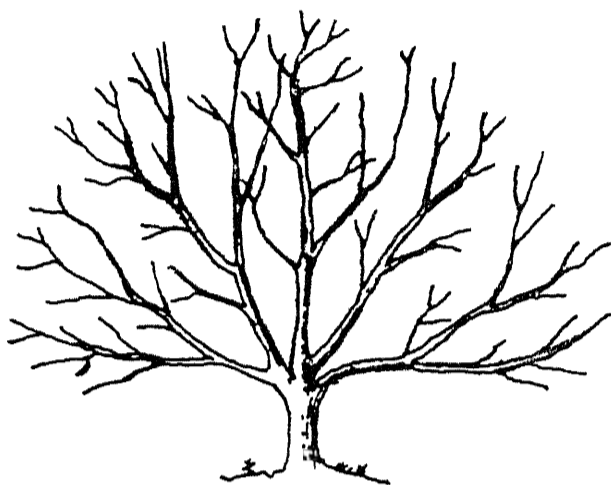

Fig. 2 A Well shaped 12 year-old Tree

one or more years without affecting the development of the trees. It is also claimed that such a practice induces early bearing. The chief objection to the practice is the added expense in handling such large trees when they are finally transferred to their permanent location.

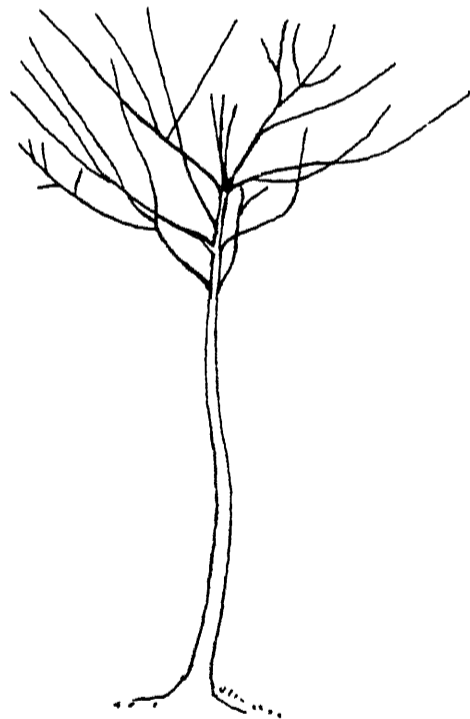

Fig. 3. Poorly-shaped Young Tree. The Head Has Been Started Too High.

First and Second Grades

Nurserymen frequently offer two grades of trees, known as first-class and second-class. Those of the latter grade are usually ill-shaped or undersized trees and may be obtained at a lower rate. Some-

times fairly good results follow the use of second-class stock, but as a rule the saving is not sufficient to warrant the taking of any chances on such trees. The largest trees of a certain age are not necessarily the best for planting. They are more difficult to handle, and as a rule are more seriously affected by transplanting. Southern-grown nursery stock is usually larger than that grown in the North. This is not a serious objection, but the extremely large trees receive such a shock at the time of transplanting that they frequently make a very slow and scanty growth the first season.

Healthy Stock

Care should be exercised in selecting stock free from disease and injurious insects. It is a common thing to find trees affected with crown-gall, woolly aphis, and San Jose scale. It is important also to make sure that the trees have been well cared for after digging. Most nursery stock is dug in the fall and either heeled in over winter or stored in cool sheds, cellars, or cold storage houses. Trees with bark that has become blackened, dry and shriveled, or soft and loose, are likely to have been injured in storage and should not be accepted.

C. D. JARVIS,
Storrs, Conn.

Age of Trees to Plant

It is the habit of many orchardists in the middle and eastern states to plant two-year-old nursery stock; but in the Pacific states the choice is almost universally for the one-year-old stock.

Professor Fabian Garcia, speaking from the standpoint of New Mexico, says:

“The age of trees to plant varies as a rule from one to three years old from the bud. In some parts of the East the one-year-old is planted, while in other parts the two and three-year-old tree is used. In special cases large trees from four to six years old can be planted with fairly satisfactory results. The general rule, however, is to plant young trees. Experience shows that the one and two-year-old apple trees are to be preferred. If the one-year-old trees are large and well grown they can be used in place

of the two-year-old, but on the whole the two-year-old is better for this climate."

It will be seen from these recommendations that there is considerable differences of opinion as to the age at which trees should be planted. This difference doubtless grows out of the experiences of orchardists and nurserymen in the different sections. It would seem that in the South, or in sections where the trees make rapid growth, that one-year-old stock is preferable; while in the northern sections, two-year-old stock is mostly used. The Pacific Northwest being an irrigated section, and the climate more or less modified by the coast winds, enables the stock to make rapid growth, and one-year-old stock is almost universally used.

GRANVILLE LOWTHER

How to Determine Age of Trees

It is very easy to determine the age of a nursery tree. The age is counted from the budding or grafting. The end of each year's growth is marked by a row of rings or scars around the trunk and branches. To tell the age of a tree, begin at the tip of a branch and follow back to the base of the tree counting the scale rings. The tree will be one year older than the number of rings. It is best to use the branches at the top. In trees on which the tips of the branches have been injured or removed, during the summer, some difficulty may be experienced in determining definitely, but this method will serve in most cases without difficulty.

The best age at which to plant trees is a much mooted question. The present tendency is to plant trees which are too old. The upper limit of age for an apple tree is three years. Two-year-old trees will be found better than older ones in most cases. The present demand for large trees causes the nurseryman to prune off the side branches along the first and second year's growth, thus in a great many instances spoiling the shape of the tree or at least making it necessary to form the head too high.

Another factor which tends to give in-

ferior trees where they remain long in the nursery is the fact that they are grown very close together, and this forces the branches to grow more in one plane which results in lop-sided trees. The shorter the period the tree passes in the nursery, the more likely it is to be a good tree when the grower receives it.

It is true the younger trees require longer to come into bearing after being planted, but the orchardist can better afford to give them one or two additional years' attention and have the opportunity to prune and care for them so they will make first-class trees, than to let the nurseryman grow them for the additional length of time, and have to give the same amount of care later on in trying to change a spoiled tree into a passably good one. It is not the intention to convey the idea that no good three-year-old trees are produced in the nursery, but with the present systems and practices the chances are very much against it.

Two years is a compromise age, as the two-year-old is less likely to have been spoiled in the nursery than an older tree, and it saves one year in the orchard before bearing. If, however, suitable two-year-old trees cannot be secured, by all means use the younger trees.

Best Height of Head—By "height of head" is meant the distance between the base of the tree, after planting, and the height at which the main branches grow out. Formerly trees with branches lower than five or six feet were not desired because when lower they were supposed to be very difficult to work under. Today no good commercial orchardist would think of planting trees with such high heads.

Economics in Low Heading—There are numerous reasons why a low-headed is preferable to a high-headed tree, but the chief one is because it facilitates orchard operations. In this day of pruning and spraying and high prices for labor in picking the orchardist does not want a tree so headed that it will require a ladder to reach the lowest branches producing fruit. The old objection that the lower branches of low-

headed trees interfere with orchard cultivation is easily met by the fact that a great many of our trees have a habit of growth which permits work under their branches even when low-headed without additional inconvenience. Those which do not have such a habit can be improved by proper pruning, and the head need be only a little higher than in the others. The low-headed tree, therefore, is rapidly becoming the only one used in commercial plantings.

The question is often asked, "What is the proper height to head an apple tree?" Authorities differ, some giving one foot as the desired height, others as much as three feet. It is scarcely wise to make any hard and fast rule as the height which will be found most advantageous will vary with different varieties. For upright growing varieties like Wealthy and Northwestern, 18 inches to two feet will be sufficient. Varieties like Longfield with a spreading habit and slender branches should be headed somewhat higher.

J. G. MOORE,
Madison, Wis

Treatment of Trees When Received From the Nursery

Just as soon as the trees are received from the nursery they should be unpacked and planted. If the ground is not ready when the trees are received they should be "heeled in." If the trees are to remain heeled in a long while be sure that the bundles are separated and the trees carefully placed in the trench. Care should be taken that the dirt should be properly placed around the roots so there will be no air spaces left. After the trees are heeled in, water them thoroughly and in this way any air spaces that are left will be noticed after the soil settles, and the holes or cracks left may be filled.

Occasionally trees arrive in very dry condition and one does not know just what to do with them. One of the best things to do is to bury the whole tree, root and top, in moist soil for a few days. By burying the whole tree it will take in moisture slowly and will gradually resume its plump condition. The prac-

tice of putting the dried trees in water is not to be recommended

FABIAN GARCIA,
Santa Fe, N. M.

Preparing the Trees for Planting

The treatment that a young tree should receive before planting consists chiefly in pruning the tops and roots. The main object of such pruning is to readjust the balance between top and root which in the process of digging is somewhat disturbed.

Trimming the Roots.—While a large root system is an indication of a vigorous tree, it is not essential to the successful development of a tree. It has been found by experiment that trees with their roots severely cut back thrive just as well as those with elaborate root systems intact. The fibrous roots on a young tree are not of value, for these are always killed in transplanting and the tree throws out a new root system. The vitality of a young tree, then, depends more upon the energy stored up in its stem than upon its root development. This is an important point, for a tree with a small root system is more expeditiously planted than one with an elaborate system. All mangled roots should be cut off cleanly and all the main roots should be cut back to about three or four inches of the trunk.

C. D. JARVIS,
Storrs, Conn

THE ROOT PRUNING OF YOUNG FRUIT TREES

Stringfellow System

The following conclusions as to the value of the Stringfellow system of root pruning were formulated by Mr. G. Harold Powell of the California Fruit Exchange some years ago while horticulturist at the Delaware Experiment Station.

Both root pruning and top pruning are helpful to a transplanted tree, for the original harmony between root and branch is disturbed in its removal from the nursery.

The Stringfellow system removes all the roots, and shortens the body to a foot or eighteen inches in length.

The advocates of the new method claim

that a stub-pruned tree develops a many tap rooted system, while a long-rooted tree forms a surface system of roots. They also claim economic advantages in digging and packing the trees, in transportation, and in planting.

An experiment was begun in 1896 and continued until 1899 on heavy clay land at the experiment station, and on light, sandy loam at Seaford, Delaware, to determine the merits of stub-pruned, three inch, and six to eight inch rooted apple, pear, peach, and plum trees; also to study some of the principles of root formation.

Sixty-two and one-half per cent of the stub-pruned trees lived on the heavy soil, 86 per cent on the light soil; 97 per cent of the three-inch trees lived on the heavy soil, 100 per cent on the light soil; 87½ per cent of the eight-inch trees lived on the heavy soil, 94 per cent on the light soil.

Twenty-two per cent of the stub-pruned trees made first-class trees on the heavy soil; 51 per cent on the light soil.

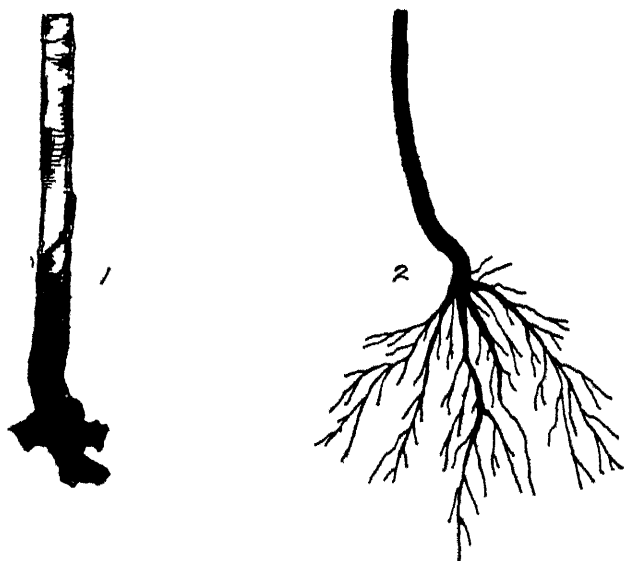

Fig. 1. No. 1 the Stringfellow Tree Pruned. No. 2 the many tap-rooted tree that is supposed to develop from it.

The roots of the stub-pruned trees did not take a more downward direction than others.

New roots arise from the ends of pruned roots, from fibrous roots, from adventitious buds at the base of the tree, and sometimes from the sides of the larger roots. They arise most easily from the smallest roots. Shortening the roots induces a development of adventitious roots which may compensate the tree for

the loss of its smaller feeders. A long root is useful to a transplanted tree mainly to anchor it in the soil while the new roots are forming. Fibrous roots may be of importance to a transplanted tree in that the earliest feeders are developed from them. The vitality of the fibrous roots is not destroyed where trees are carefully handled.

The direction which the new root system assumes is governed by the character of the soil, by the distribution of plant food and moisture in it, and by the natural habit of the tree. The roots seek the strata of most congenial moisture and accessible plant food

Stub-pruned trees are at a disadvantage on heavy soils, on soils that freeze deeply throughout the winter, in a dry fall or spring, or in soils that are slow in warming.

Stub-pruned trees, with branches shortened to correspond, frequently develop a one-sided root system and an ill-formed top.

The stub-pruning system is not founded on principles of plant growth. It is a practice with merit in local conditions. The claims for the system are based upon a succession of misconceptions of the laws of plant growth. The advocates have induced a careful study of the development of the roots of plants, and therein lies its value as a contribution to horticultural knowledge.

Care of Trees from Nursery to Planting Time

After goods leave the delivery yards of the nurseryman they are beyond his control. He has no legal right to dictate the care his stock shall receive. The best he can do is to advise the planter, and when this advice is not solicited it places the nurseryman in the rather awkward position of presuming on the intelligence of the planter; yet, if any misfortune overtakes the planter in his horticultural venture, the nurseryman is likely to receive the blame.

After 23 years of experience in the Rogue River valley, the writer is thoroughly convinced that if the losses due to the planter's inadequate knowledge,

his neglect of known duties, and the indifferent care on the part of the agent or tree dealer, were eliminated, the remaining loss could be carried by the nurseryman very gracefully. The instructions given in this article are designed to eliminate much of the worry and financial loss of the beginner.

Many suggestions here made will apply to any part of the country. They are written, however, expressly to meet conditions in the Rogue River valley, Oregon.

Go Properly Prepared to Receive Stock

Before going to the nursery or freight office for your stock first provide yourself with canvas, horse blankets, or something of that nature sufficient to properly protect the roots from drying or chilling while returning home, unless the weather is very favorable—a mild foggy day, for instance. The orchardist will have little trouble if he will always remember that a tree, although dormant, is alive and must be handled as a living plant.

Examine Stock Carefully When Received

On receiving nursery goods examine each bundle, and, if necessary, each tree carefully. Note the condition of the plants and see that each bundle is properly labeled, refusing any stock that has a badly mutilated or insufficient root system, and trees that show signs of having been dug while immature. Trees which have been removed from the nursery row prematurely will show signs of withering at the extreme tips, and soon after the first little freeze will develop a dark spot in the center of the soft terminals. A cross section of the main roots will show this same dark spot in the center if the stock has been subjected to frost or other abuses. Roots of trees that have suffered from exposure will also show a brownish coloring between the bark and woody part of the root, although the outer portion of the root may appear uninjured.

If damaged stock is received at freight office, proper care should be given the goods and a prompt report made to the party from whom the goods were received.

A Common Error

Too much emphasis cannot be placed upon the necessity of heeling in the plants

immediately upon arrival at the farm. *They should under no circumstances be left out over night.* This is the stumbling block over which many fall. Stock left exposed over night may receive either little or no injury, or may be either badly damaged or ruined, according to the changes that take place in the temperature. The labor involved to properly protect the stock is so trivial that no one can afford to take the risk.

Heeling-In Nursery Goods

Seek out a spot of well drained soil, sandy loam if possible, where no harm can come to the trees by the farm stock browsing or otherwise mutilating them. Spade a trench about a foot wide and two spades deep, leaving the loose dirt at the bottom. Govern the length by the amount of stock to be taken care of. Separate the stock so that all the bundles of each variety may be kept together.

Cut the lower string on the bundles as the roots are placed in the trench, standing the bundles at an angle of about 45 degrees and spreading the trees somewhat so the roots may be more readily covered with the dirt from a second trench.

When the first trench has been filled with trees begin again as in the first place by cutting a trench close to the roots of the trees just placed, being careful to see that all the earth removed from the second trench is worked well around and over the roots of the trees in the first, allowing the dirt to cover a few inches of the base of the trees and repeat until all the stock is heeled in.

Care should be exercised in heeling in small plants, such as strawberries, to avoid covering the crown of the plant, and a light covering of leaves or some such protection should be given them. Roots and bulbs should be entirely covered with earth and stakes placed to properly mark their location or they should be packed in moss and kept in a cool but frost-proof building.

Pruning and Preparing Stock for Planting

Care should be exercised to not bend the stock unnecessarily while being re-

moved from the heeling grounds. Remove or thin out any roots that have grown in a tangled mass, roots that were mutilated in the process of digging, and cut the tip of each of the main roots, using a sharp knife or some suitable instrument, remembering always to make the cut at an angle so that when the tree is set in the ground the cut surface will be down. Remove all sucker sprouts from the base of the tree, being careful to cut these close to avoid further sprouting. If stock is to be held for late spring planting it should be removed from the heeling grounds during favorable weather about the middle of February, the roots pruned and the stock heeled in again.

A shady place for the heeling grounds will aid greatly in keeping the stock dormant for late spring planting.

No stock of any kind should ever be removed from the heeling grounds during freezing weather or while the trees or plants are frozen, though the weather may be moderating at the time. After a cold spell allow the frost to entirely disappear from the grounds before disturbing the stock. The tops of trees should not be pruned until after they are planted, except to save damaged stock as explained later.

Care of Stock While Planting

The stock is now ready for its final place in the field but it must have the same careful protection from drying or chilling winds as at any other time. Pieces of canvas or burlap sacks may be used for this purpose. If planting is done any time after the first of March the roots of each tree should be dipped in a thick batter of mud, and care should be taken that the mud does not dry on the roots before the tree is set. This mudding the roots is very important. Never allow bundles of trees to lie exposed to the wind and sun nor place them in a creek to remain until needed.

Treatment of Frosted Trees

If you notice frost in a box of trees on opening do not remove the goods but close the box carefully and place it in a cellar, cement building or some such place where it is cool but free from

frost. Cover the box with sawdust, canvas, blankets or any convenient material to prevent the stock from thawing out too rapidly and leave undisturbed for a week or ten days before heeling in the ground.

Treatment of Stock Received Dry

If goods are received dry, dig a trench, in sandy soil, large enough to bury the trees root and top about eight or ten inches under the surface, and if late in the spring pour a few bucketsful of water over the stock after the trench has been filled, and let remain for a few days until on examination the stock is found to be fresh and well filled out. Many times stock received in bad condition can be saved if treated in this manner though any undue exposure will weaken the vitality of a tree and all such damaged goods should be severely top pruned when heeled in or planted.

Care of Evergreens

The roots of all cone-bearing trees, and, in fact, most all evergreen plants, are very sensitive to exposure, and should never be handled without being properly balled. The novice should never order goods of this kind shipped with naked roots in order to save a little on first cost or freight. The roots of rose bushes, while not evergreens, should never be allowed to become dry or frosted.

N. S. BENNETT,

Eden Valley Nurseries, Medford, Ore

PEDIGREED TREES

Definition

(1) "A selected source of multiplication which does not require sexual generation."

E. J. WICKSON.

Trees propagated by buds or scions taken from trees with known records for superior qualities.

Introduction

At the present time there are comparatively few trees whose "pedigree" extends beyond the first or second vegetative generation. The term as here used does not apply to any form of sexual generation.

(1) Correspondence, 1912.

It is a mere registry of buds or scions from a known tree or trees. By "vegetative generation" is meant successive graftings from former graftings.

Controverted Points

On account of the fact that this method of registering trees on the part of nurserymen has been but recently used, and on account of the unfortunate circumstance of employing the term "pedigree," which has heretofore had a very definite application to the breeding of stocks of all kinds from the seed or through sexual generation only, some controversy has arisen as to the validity of the claims of those who profess to employ this method of selection. The controversy has arisen both because the use of the term has been disputed, and because of the wide diversity of opinion as to the value of the stocks so selected over those selected with ordinary care so as to procure trees "true to name."

The former controversy will be settled when the horticultural world becomes accustomed to the use of the term in this connection or when a new and suitable term comes into general use.

The other controversy is of far different nature and will not be settled until more is known about the facts and nature of plant variations and the means by which they are preserved and transmitted. It hinges about the questions, first, as to whether observed variations, in trees of the same variety or strain, which show in themselves a tendency to heavy or regular bearing, freedom from disease, shape or color of fruit or other desirable quality, are due to soil, moisture, fertility, care or other environmental cause and so not transmissible; and, second, as to whether bud sports or mutations are of frequent enough occurrence to enable the nurseryman to improve his stock on a commercial scale.

Common Ground

It is quite generally admitted, probably universally, amongst horticulturists that bud sports do occur at rare intervals and give rise to new varieties. But it is not known what these sports will do. They may give rise to a beneficial

variation and they may produce a mere freak. However, it offers an occasional opportunity for selection. It is pretty generally admitted that variations in tree fruits within a given variety are in the main due to environmental causes. There is the same general tendency to regard the theory of transmissible variations within the tree itself, outside of the occasional sport, as unproven. (2) W. T. Macoun of the Dominion Experimental Farms has had apple trees under observation for 14 years and is "inclined to believe that there is variation in the tree itself, but has no proof apart from the variation in yield." The proof will not be forthcoming until there can be opportunity for a record of a number of vegetative generations under various environments. So far as known no such record of importance exists.

Whitten Experiment

J. C. Whitten of the University of Missouri has conducted experiments through 12 years with strawberries and Ben Davis apples. With regard to these experiments he concludes:

(3) "I doubt very much whether bud variations of a permanent nature capable of being transmitted to the buds used for subsequent propagation occur frequently enough so that a given variety may be really improved by selecting buds from trees that are known to be especially good producers. Of course every one must recognize the fact that bud sports or bud variations do occur. In my judgment a bud variation or bud sport occurs very rarely and when it does occur it is so different from its parent as to be a different variety. When such a bud sport occurs it may be reproduced by propagating it from its buds as a new variety.

"Here at the experiment station we have tried to increase the productiveness of Aroma strawberries and of the Ben Davis apple by keeping a record of the production of the individual plants of each. In the case of the strawberries the best producer in the patch yielded

(2) Correspondence, 1912.

(3) Correspondence, 1912.

eight times the production of the poorest yielder, yet when we allowed these parents to make runners and propagated from them by these runners we found just as much variation in the runners produced from the one as we did among those produced from the other. In other words, we got equally good and equally bad plants in each lot. That was continued after 12 years of selection.

"In the case of the Ben Davis apples we kept a record of the production of individual trees in an orchard where one tree was found to be uniformly a low yielder and where three trees were found to be uniformly high yielders. Scions were taken from the low yielding and from the high yielding trees. These were worked on seedling roots and finally planted in the orchard so that in a row throughout the orchard there occurred first a tree from the high yielding parent, then a tree from the low yielding parent, and so on alternating throughout the row. These trees have been in bearing after four years and in the three crops produced as much variation among the different trees apparently as there is in any other Ben Davis orchard. We have as good yielders taken from the poor yielding parent as we have from the others. On the other hand we have as poor yielders taken from the good yielding parent as we have from the others.

"I know of a few instances where attempt has been made to secure high yielding trees by selecting buds from especially good producing trees, but I do not know of any instances that are authentic where anything has been gained by this practice. I do not want to conclude that it is impossible for bud variation to occur in an occasional tree in which the variation expresses itself simply in the form of great productivity, but I do believe that the fact that a tree happens to have a high record as a producer is no indication of the fact that this quality would be transmitted to its bud offspring.

"Personally I believe that variations that come from buds are due to something which lies within the tree or some

stimulus applied to the bud while it is forming. I do not believe that differences due to environment, soil formation, degrees of fertilization, freedom from diseases, pests, etc., are capable of being transmitted to the offspring. I am not ready to conclude that individual parent trees might not be found which would be capable of transmitting larger productivity through their buds. I know of no direct evidence up to date, however, that we can secure higher yielding trees of a given variety by this method. I think further experiments should be tried out by those who happen to know of especially high yielding specimens of fruits before one could reach a positive conclusion."

Regarding Laws of Variation

The causes of variations through heredity are not the same as the causes of variation through environment. Variations of budded stocks seem to follow environmental causes rather than hereditary causes. When you cut scions from a tree, set them on new roots and transplant them to various soils and climates, you are virtually testing that same tree in a variety of environments and the variations which occur from the original type will be due to environment. The thing to be determined is, Will changes which are due to changed environment become permanent; for example, will the Spitzenburg, which produces an apple of a certain size, shape, flavor and color in the Yakima country, produce the same fruit when transplanted to the Ozark mountains?

The conditions under which plants will vary may be summarized as follows: The nature or quality of the food; the quantity of food; the nature of the climate; the nature of the competition under which the plant has to survive; the nature of enemies, such as fungi, insects, animals or other injurious circumstances; nature of the care given; all these in relation to the nature of the organism, its vigor, health, and equilibrium of all its parts.

U. P. Hedrick of the Geneva experiment station (New York) has the follow-

ing interesting things to say on this point

(4) There are variations due to the effect of the environment of the plant. The richer the soil, the more sunlight, the better the care, the greater the freedom from insects and diseases and the longer the season, the more vigorous is the plant, the more fruit it produces and the larger and more perfect is the fruit. But though these changes and conditions produce a direct effect upon the plant during its lifetime, there is no evidence to show that any of the variations so brought about can be transmitted from parent to offspring. The fruit grower who wants to perpetuate such variations, must renew for each generation the conditions which gave him the desirable effects. It is a question of 'nurture,' not of 'nature.'

"To illustrate: A man living in Northern Michigan had a Spy tree which bore small, green scrawny Spies. He attributed the poor apples to the *nature* of the tree and talked much of the Spy tree in mother's yard 'back East' that bore marvelous apples. He brought on grafts of mother's Spy. In due time the grafts bore the same small, gnarly, green Spies. Northern Michigan Spies are worthless because of climate and soil and not because of the tree. * * *

"A Baldwin tree taken from New York to Virginia produces an apple different from the New York Baldwin; taken to Missouri, the Baldwin is still different; taken to Oregon, it is unlike any of the others. If the trees are brought back from these states to New York, they become again New York Baldwins. It is not likely that selection can change this.

"If it were true that characters acquired because of environment were inheritable, the resulting medley would be overwhelming. Let us see where the transmission of acquired characters would lead us in a particular case—taking, it is true, a somewhat extreme one. If a growing apple be put in a bottle, it will continue to grow and assume the

shape of its covering, making a bottle-shaped apple. If one such bottle be red and another blue, the color as well as the shape of the apples will be changed. If many variously shaped and colored bottles be used and if from their seeds or buds the resulting products come true, especially if the seeds were crossed, the imagination cannot compass the confusion in form and color of apples which would result in a few generations.

"The Geneva station has an experiment which gives precise evidence on this question of pedigreed stock. Sixteen years ago a fertilizer experiment was started with 60 Rome trees propagated from buds taken from one branch of a Rome tree. Quite as much variation can be found in these trees from selected buds as could be found in an orchard of Romes propagated indiscriminately and growing under similar conditions. Data showing the variations in diameter of tree and in productiveness can be found in Bulletin 339 of this station, and will go far to convince anyone that uniformity of behavior as regards vigor and productiveness of tree and size and color of fruit cannot be perpetuated.

"We have another experiment at Geneva which ought to throw light on pedigreed stock. Baldwin apple trees have been purchased from 104 nurseries in all parts of the Union. Some of these have been propagated from bearing trees; others have come for generations from nursery stock; some are on French crab, others on Doucin, and others on Paradise stocks. If allowed to come into bearing in the regions in which we obtained the trees we should have 104 more or less different trees bearing variously shaped and colored apples. What will the harvest be when all come into fruiting in the station orchard? Will they resemble the Baldwins from the various regions from which the trees come or will they be New York Baldwins?

"What I have said in regard to the improvement of fruit propagated from buds is now the accepted theory in regard to the improvement of plants grown from seed. To be of any value in plant improvement a variation must be inherited;

(4) U. P. Hedrick, N Y Circ. 18.

mutations are inherited; variations resulting from environment are not inherited or at least there is no indisputable evidence of such inheritance. Fluctuating variations in vigor, hardiness, and size of plant and in color, size, amount and quality of fruit play little part in the improvement of plants. Selection was formerly considered a continuous and cumulative process; the revised theory is that it is a discontinuous process and new characters are added in one leap. Somehow, somewhere, sometime in the life of a species of plants, a wholly new character is added, or removed, and the variation is transmissible to the succeeding generation.

"May it not be true that size of fruit, vigor, hardiness or productiveness of plant may appear as mutations and be heritable? These characters may appear as heritable variations but it cannot be known without precise experiments for each case whether or not they will be inherited. No fruit grower or nurseryman is warranted in assuming that the qualities named can be handed down—the chances are many to one that such variations are due to nurture and are not transmissible.

"For several years the speaker has spent much time in studying the histories of varieties of fruits. In 'The Grapes of New York,' he has had to do with about 1,500 grapes; in 'The Plums of New York,' 2,000 sorts of plums; in 'The Apples of New York,' with about 700 kinds of apples. When this knowledge of thousands of varieties is focused, one sees in fruits stability and not variation. The generations of varieties of fruit do not change. The Baldwin apple, Bartlett pear, Concord grape, Montmorency cherry have not changed. In the station fruit exhibit are Greenings from a scion of the 'original' Greening tree, 200 years old when the scions were taken; besides them are Greenings grown from trees propagated from nursery stock. The characters of the two lots of fruit are identical. If indiscriminate taking of buds for propagation means changes, we should have innumerable types of Baldwins, Bartletts, Concords,

Montmorencies and these two lots of Greenings ought not to look alike.

"There are, probably, more than one strain of some varieties of fruits, as of the Baldwin for example. But these strains are few, not more than two or three for any variety and but one in the great majority of fruits. No one knows how strains have arisen—certainly not by premeditated selection. The fact of these occasional strains does not alter the statement that the great majority of the infinitude of variations in every orchard are not transmissible."

The following letter from Alfred G. Gulley of the Connecticut station corroborates the view of Professor Hedrick:

(5) "I have no doubt that variations in tree fruits are chiefly due to environmental causes and I have not seen or produced variations due to causes which lie within the tree itself. If the latter is true why has there not been use made of it and off year Baldwin orchards produced? On the other hand, if true, how do we have standard varieties at all? Slight permanent variations would come and varieties change from the original. Bailey's 'Plant Breeding' says that a variety will completely change in a century. I doubted it, so some 12 years ago sent over to Rhode Island and obtained scions from the reputed original tree. Whether original or not, it was known to be Rhode Island Greening, and at the time I got scions had had a written bearing record of 175 years, nearly two centuries. I grew this alongside another tree, both same stocks, and grafted from Rhode Island Greening trees obtained in New York state, which no doubt had been changed a dozen times or more since leaving the original. I placed samples of fruit from both trees on the tables at the Western New York Horticultural Society two years ago and had the pleasure of hearing Professor Bailey himself say there is no difference. I have read Professor Hedrick's bulletin (Circ. 18, quoted above.—Ed.) and not only agree with him but in the year 1905 presented the same idea with some results along

(5) A. P. Gulley, Correspondence, 1912.

other lines of work at the Western New York Horticultural Society meeting, and had the privilege of having Professor Hedrick and George T. Powell climb all over me for taking such notions. Upon receiving the bulletin I wrote to Professor Hedrick and congratulated him upon his change of heart. I quote from his reply, 'Your letter in regard to Circular 18 is at hand. We live to learn. The theory that varieties of fruit could be improved by bud selection seemed so plausible to me that without stopping to analyze it very closely and without doing any experimental work, I accepted it and preached it. I remember very well disagreeing with you at the Rochester meeting. Your long and wide experience should have made me more careful. Almost from that meeting I became a doubter and for the last two years have given the subject of pedigreed trees a great deal of attention in the various aspects put forth in Circular 18.'

"I think much of the trouble lies in the attempt made by many to reason that seed and bud propagation should produce the same results. They are not the same. Many are not willing to take the time to test their propositions. I was just 10 years working out the Greening matter. I believe there is something in the mutation theory. I think the Colamer apple belongs here, as I do not understand that any claim has been made that it is improved, but discovered."

Other Opinions

Not a few reliable nurserymen believe that the "pedigreed tree" is a species of faking, misleading to say the least, the only claim that can be legitimately made being that care has been exercised in the selection of scions from healthy trees and in keeping them true to name. One noted specialist puts it: (6) "Selecting scions for type is rational, selection for variation is a dream as far as we now have any knowledge." Perhaps this view is extreme, as there are other men apparently sincere and among them some thoroughgoing scientists who are sufficiently convinced that there is something

(6) E. J. Wickson, Correspondence, 1912.

in the idea that they are devoting time and expense to its further study. Burbank thinks that there is truth in the theory but that (7) "its value has been greatly overestimated. Ten valuable variations are produced by seed to one bud variation."

In fairness to the advocates of the pedigree theory it must be said that one bit of positive evidence is worth a whole world of merely negative evidence. The work of A. D. Shamel, of the Bureau of Plant Industry, in California, on citrus bud variation promises to yield important results. The work here has been greatly simplified by the fact that practically all of the navel oranges in California are the descendants of two trees. Following is a brief account of the results thus far secured:

"Our four years' work here has given us a definite line on the frequency of citrus bud variations, their relation to the permanence of citrus types, and the comparative value of these types.

"We have determined the standard types of the Washington and Thompson navel orange, Eureka lemon, Marsh's seedless pomelo, and Valencia orange and the 'off' types of these varieties. We have developed a practical tree performance record system now in use in over 5,000 acres of citrus fruits, for determining the trees which are to be rebudded, the 'drones.'"

A. D. Shamel, Correspondence, 1912.

The Nature of the Budding Operation

A brief statement of the nature of the process which is employed in budding and grafting might be helpful in clearing the whole problem of certain misconceptions which arise out of the necessity of employing terms which belong to another field.

(8) "When you take a bud or limb from a given variety of tree, and insert that bud on another stock to which it attaches itself and from which its life is obtained, for the bud to continue its growth simply amounts to continuing or extending the length of the branch of the original tree, and it can no more change the na-

(7) L. Burbank, Correspondence, 1912.

(8) F. Wiggins, Correspondence.

ture of the original tree than you could effect a change in the limb of the original tree which you have not detached. If it were possible to effect such change all nature would be in a chaotic condition."

If, however, bud variations do occur these varieties may be continued and extended by budding from the variant stock.

The Breeder's Analogy

Another prolific source of misconception arises out of the use of analogy from the breeder's experience and applying it to the propagation of trees by buds and grafts. A brief statement of the breeder's problems is all that can be given here, but enough to indicate that the two methods of propagation are not analogous.

New Laws of Breeding

(9) The work of Gregor Johann Mendel established the fact that some of the characters, of both plants and animals, are inherited unchanged, passing down through each subsequent generation. Many of them may be hidden in the first generation of progeny and in a fraction of the descendants of each subsequent generation by the "dominance" of stronger, opposed, or differing, characteristics of the same group. But both the "dominant" and the "recessive" (weaker or hidden) character of a Mendelian pair reappear in pure form in part of each generation after the first; so that the descendants of two parents, both showing the same one of these pure characters, will always be like their parents in respect to this character.

Now, the problem of the breeder is to ascertain what characters follow this law—for not all do—and to secure the ones desired in pure form and in suitable combinations. When once secured as desired in two parents, the descendants may be depended on to show the same characters and not to "revert" to some form not wanted. But, even simplified as it is, the problem is still very complex; for the features or characteristics we think of as separating one plant or animal from

another may each be made up of two or more heritable characters, and the possible combination, in any individual, of these varied "unit characters" are exceedingly numerous and varied. All these variations must be secured and checked by growing multitudes of seedlings, of at least two generations, before we can be positive of our ground on more than a few characters.

In the case of the bud or scion you are not dealing with "inheritance" at all, but with a single individual which you wish to multiply in such a way as to preserve the qualities which it now possesses. Stability then, so far as those qualities are concerned, is what is wanted and not variation.

For the benefit of those who may wish to make a further study of the problem the following references are appended.

References

- 1900—Hitchcock, A. S., Plant Breeding Bud Selection (Amer. Gard 21 [1900] No. 266, P. 57)
- 1902—Kellog, R. M., Bud Variation in Strawberry Plant (Internat. Conference Plt. Breeding and Hybridization, N. Y., Sept. 30-Oct. 2, 1902).
- 1902—Powell, G. T. Value of Improved Methods in Propagation of Fruit Trees. (N. J. Hort. So. 27 [1902] P. 125-35. Fig. 2.)
- 1902—Corbett, L. C. Improvement of Roses by Bud Selection. (Internat. Conference on Plt. Breeding, N. Y., 1902.)
- 1904—Jordan, A. T. Improving Fruits by Bud Selection. (American Agr. 74 [1904], No. 9, P. 160.)
- 1905—Blackwell, O. W. Bud Variation, Facts That Prove Its Occurrence. (Country Gent. 70 [1905], No. 2717, P. 197.)
- 1905—Macoun, W. T. Individuality of Fruits. (Rep. Can. Exp. Farms, 1905, P. 105-6.)
- 1905—Symposium, Apple Scions from Bearing Trees. Influence of Stock. (Rural New Yorker, 64 [1905], No. 2907, P. 741.)

(9) Geneva Bull. 350, Popular Edition.

- 1905-8—Munson, W. M. Variation in Fruitfulness of Individual Trees (Maine Bull 122, 139, 155, 134, 137, 138)
- 1907—Card, F. W. Scion Selection and Blooming Dates (R. I. Rept 1907, P 211-14, 220-65 Pls 7.)
- 1908—Powell, G T. \$1,000 an Acre from Pedigreed Trees. (Country Life in Am. 13 [1908], No. 5, P. 504-6, 538, 540 Fig. 12.)
- 1909—Beach, S. A Rept of Com. on Breeding Vine and Tree Fruits. (Am Breeders Assn , Vol. 5, P 28, 1909.)
- 1909—Ballou, F. H. Bud Sports in Apples. (Ohio Circ. 94, P. 70. Fig. 20.)
- 1911—Wright, W. J. What About Pedigreed Trees? (Rural New Yorker, P. 155, 1911.)
- 1912—Hedrick and Wellington (N. Y. Bull. 350)
- 1912—Hedrick, V. P. Pedigreed Nursery Stock. (N. Y. Circ. No. 18.)
- 1912—Shamel, A. D. (Mo. Bull. Cal. Com. Hort. 1, 9, 1912.)
Am. Breeders Assn., Vol 8, P. 497.
Bu Plt. Indust., Circ. 77.
E. S. R., Vol. 19, P. 1142; Vol. 16, P. 265.
American Agriculturist, Vol. 74, No. 9, P. 60.

WM. WORTHINGTON

Pedigreed Stock, Does It Pay

Nurserymen understand what is meant by "Pedigreed Stock." They may believe in it or they may not.

There has been a good deal of discussion as to the correctness of the term "pedigreed," as applied to plants. A "pedigreed" animal infers known parentage on both sides. With fruit trees and other plants the female parent is often known, but not the male, and many of our best fruits are what is known as chance seedlings, both parents being involved in obscurity.

Moreover, a flower, or a fruit (using the term "fruit" commercially, not scientifically) may be pedigreed in the most literal and scientific sense, being bred by artificial methods, and still be worthless

so far as any economic or commercial value may be considered.

The term "pedigreed," however, implies exception and fixed quality, and that is what we desire; no other name has been proposed, except "selected," which is meaningless

Pedigreed stock is simply the propagation of selected plants, whether bud variants, mutants, or by whatever name they may be known by scientists.

There is at present in Southern California a systematic work being carried on under the direction of an expert sent out by Dr. Galloway of the Department of Agriculture, to segregate certain individual citrus trees which have made a record as to quality of fruit, good bearing habits, and general vigor, and to use these trees from which alone to propagate.

The leading citrus growers believe in bud variation, and its propagation, or perpetuation by budding or grafting, and are working to the end that their orchards may be improved by breeding up. Some growers already are budding over their bearing trees from these individual specimens. Such trees will surely be "pedigreed."

An increasing number of fruit growers all over California believe in pedigreed trees, the theory and practice of selecting individuals from which to propagate being warmly upheld by Professor F. T. Bionetti, of the University of California, Mrs. M. E. Sherman of Minnewawa, and others. Occasionally most distinct bud variations are met with, or sports, which are entitled to the classification of a new variety.

My attention was first called to this variation of individuality in 1882 when studying particularly what we call "French Prune." I have a water color sketch, made at that time, showing the different types of the French Prune, but all propagated as one. These "types," or variations are just as fixed now as 25 years ago, and no one has endeavored to segregate them until I commenced this work in 1905 by propagating only from marked individuals.

But the question arises, "Does it pay?" And this question is paramount with

the business man. Few of us can afford to be reformers or philanthropists.

It pays, in theory, to sell good goods rather than poor ones. It pays, ethically, to do right rather than wrong. It pays, to some extent, by being advertised as progressive, or which is generally the case, as a crank. I admit that this is its best feature, commercially.

It does not pay when the majority of planters, encouraged by the facetious and skeptical attitude of some leading horticultural journals, regard it as a dose of nurserymen's buncombe, or species of humbuggery.

It does not pay when the majority of planters take little or no interest in plant breeding, and even decline permission to examine and mark trees for buds.

It does not pay whenever the planter who professes faith in pedigreed stock refuses absolutely to pay one cent more for such trees, although that would not compensate for the great added expense of procuring buds from trees entitled to be called "pedigreed."

It might be made to pay handsomely, both nurseryman and planter, if the two would work in unison in the effort to improve the standard of our fruits.

There are growers, of course, who would do this, as there are also nurserymen who would seize the opportunity to advertise their stock by using the term "pedigreed," without the shadow of reason for doing so justly. The work, at best, could be but very gradual, although I have already seen a nursery firm advertising "pedigreed" apple trees for sale by the million!

Personally, I believe the work can only be done practically in a small way by individual orchardists co-operating with some neighboring nurseryman, and thus actually propagating some known and fixed bud variation.

LEONARD COATES,
Morganhill, Cal.

LAYING OUT THE ORCHARD

The Orchard Chart

Assuming that the decision has been reached as to the general plan of the orchard, it is better, before active opera-

tions are begun, to prepare an orchard chart drawn to scale on heavy paper with ink with a point or cross for each tree with the name of the variety along the line of each row, if more than one variety is planted. There are several advantages in this method. One is that if mistakes are made they are more easily corrected on paper than on the ground after work is begun; another is, that the whole plan of the orchard can be seen at any time, and will be useful for future reference. Further, if a record or a chart is made the labels can be removed from the trees, which is somewhat important because frequently these labels attached to the tree cut the bark, prevent the flow of sap, and damage the tree in its future growth. The chart with the place and name of each variety is better than labels on the trees because it is an instrument to which reference can be made at any time in describing the land if it should be offered for sale; in bookkeeping, if the profits of certain trees are to be recorded; in replanting, if some trees die; and in grafting.

GRANVILLE LOWTHER

Systems of Planting

The most important thing to be considered in laying out an orchard is the equal distribution of the trees. There are several well-defined systems, but only four need to be considered here. These are the *square*, the *rectangular*, the *quincunx*, and the *hexagonal* systems. The choice of any one of these systems will depend largely upon whether the orchard is intended to remain as it is originally started, or whether some of the trees are to be removed when they begin to crowd.

In the *square* and *rectangular* system, the one usually followed in New England the rows run at right angles, leaving each set of four trees in the form of a square or rectangle, depending upon whether the trees are planted the same distance apart each way. The chief objection to this system is that the trees are not equally distributed, there being a large open space in the center of each set of four trees. When fillers are to be planted and thinned out later, this sys-

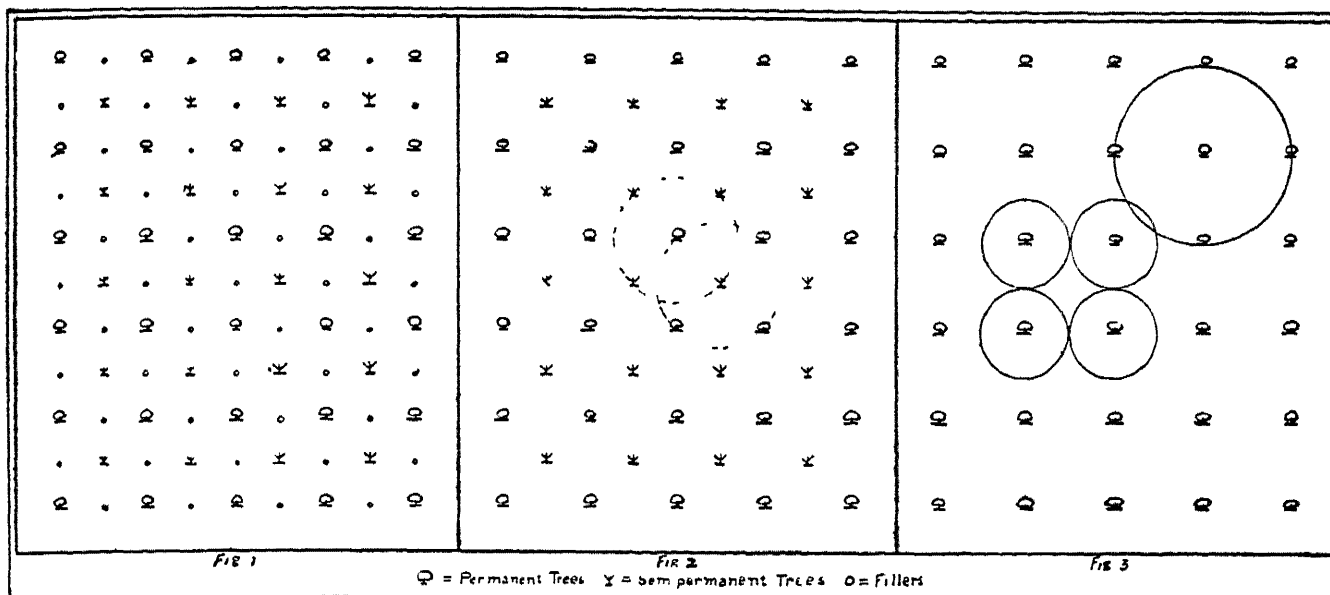

Plate I. The Rectangular Method of Laying Out an Orchard Fig 1 shows the arrangement of the trees with fillers Fig. 2 shows the arrangement after the fillers have been removed, leaving just half the number of trees. This arrangement is sometimes called the quincunx system The tree in the center of each group of four is a semipermanent tree and may be removed later if necessary Fig 3 shows the final arrangement after fillers and semipermanent trees have been removed. Observe the large, open space in the center of each group of four trees.

tem is very suitable, for the fillers may be removed without affecting the arrangement. As shown in Plate I, Fig. 1, the trees may be started say, 20 feet apart, giving 108 temporary and permanent trees to the acre. When they begin to crowd, the fillers or temporary trees, which compose the alternate diagonal rows, may be removed, leaving 54 trees to the acre, as shown in Plate I, Fig. 2. It may be seen that the trees are still in small squares (28.28x28.28 feet) running cornerwise of the orchard and in larger squares (40x40 feet), with a tree in the center, running across the field. These center trees may be called semi-permanent trees. They may either be the same as the fillers or the permanent trees, and if necessary may be removed later, leaving 27 trees to the acre, 40 feet apart each way.—Plate I, Fig. 3. To relieve the crowding, it is not usually necessary to remove all the fillers at once, and this system allows two thinnings without seriously affecting the arrangement. This system is not so well adapted to orchards without fillers as either of the other systems.

In the *quincunx* system the trees are arranged in squares with a tree in the center. It is the same in arrangement as the rectangular system partially thinned, as shown in Plate I, Fig. 2. The extra

tree in the center of the groups allows twice as many trees to the acre as the straight rectangular system, and the trees are more evenly spaced. It is also suited to filler planting, for the trees in the centers of the squares may be removed at any time, leaving the trees in larger squares.—Plate I, Fig. 3. Where fillers are used the rectangular and quincunx systems are very similar, for one is readily changed to the other by the process of thinning. For use in orchards without fillers the latter system is preferable, but neither of them is as suitable for this purpose as the next system to be described.

For Permanent Orchard

The *hexagonal* system gets its name from the fact that the trees are arranged in hexagonal or six-sided groups, with a tree in the center, as shown in Plate II, Figs. 2 and 3. The space between each group of four trees is diamond-shaped. The advantage of this system is that all the trees are equidistant, giving equal distribution of air, light and soil. It is undoubtedly the best system if the trees are set so far apart that the orchard will never require thinning. On account of the equal distribution, more trees may be planted to the acre than by any other system. It is not so well adapted to filler planting as either the rectangle or quin-

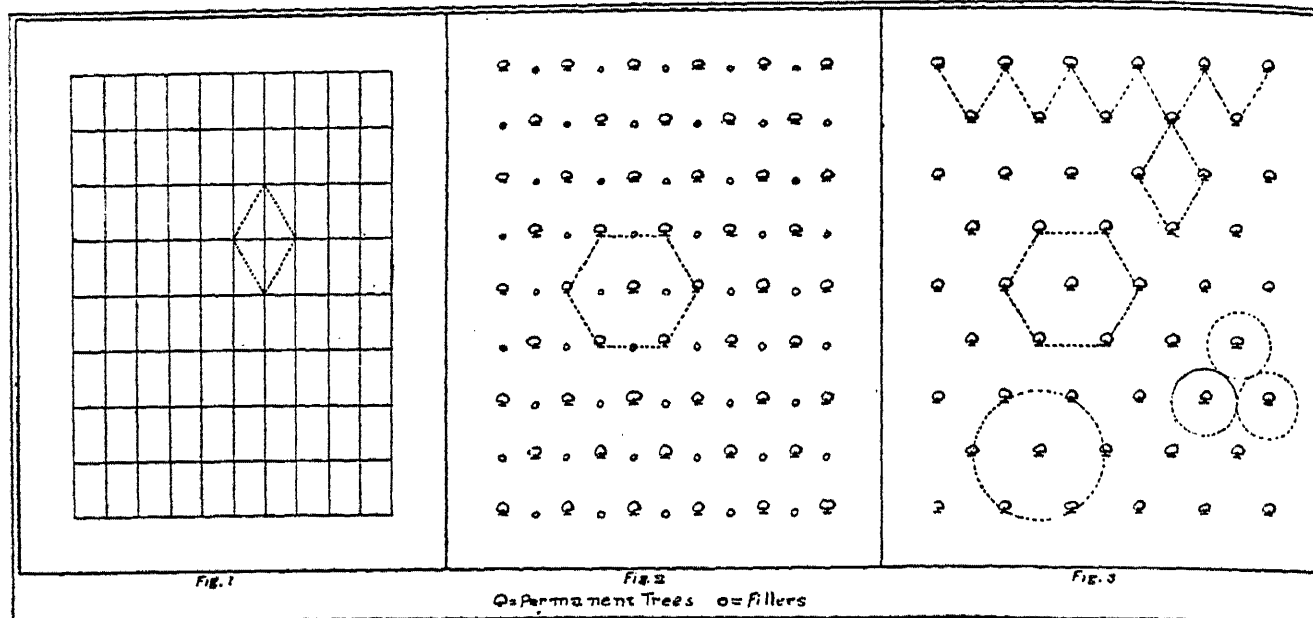

Plate II. The Hexagonal Method of Laying Out an Orchard. Fig. 1 shows the method of marking off the field. Fig. 2 shows the arrangement of the trees with a filler in the center of each group of four permanent trees. Fig. 3 shows the arrangement of the trees after the fillers have been removed. Observe that the trees are equidistant from each other and that there is but a small, open space in the center of each group of three trees.

cunx systems. Where the trees are set sufficiently far apart, say 36 feet, an extra tree may be set in the center of each diamond, as shown in Plate II, Fig. 2. This would place the tree rows 30 feet apart, and 18 feet apart in the row. As a result the trees would be arranged in rectangles, 18x30 feet, giving them plenty of room one way, but making them somewhat close the other way. Trees planted in this way may be retained longer than when they are planted but 18 feet apart. Following this method, 80 trees to the acre may be set, half of which would be fillers. If fillers are used in this way, it would be advisable to have the closer planted rows run east and west to admit more sunlight between the trees. If the distance between the permanent trees is increased, say to 42 feet, a filler may be placed between each pair of permanent trees in every direction. This would retain the hexagonal arrangement, but the hexagons would be only half the size of those formed by the permanent trees. With such an arrangement there would be four times more fillers than permanent trees. When the trees commence to crowd the thinning may be done by removing every alternate row across the field, leaving the fillers in the center of the diamond a few years longer. While the rectangular system seems to be better suited to filler planting, the hexa-

gonal method undoubtedly gives the best distribution of the trees after the fillers are eventually removed.

Setting the Stakes

The determination of the correct position of the trees is often one of the most difficult tasks in connection with the starting of young orchards. The problem is a more serious one when large areas are considered and when the location selected is on irregular and uneven land. For convenience in cultivation, and also for the sake of appearance, the trees should be set in such a way that they will be in line in all directions. With this in mind it is usually advisable to indicate the position of each tree by a stake, and to lay out the whole field before setting the trees.

In square or rectangular fields the stakes for a row of trees on all sides of the orchards may be set by measuring the distance into spaces of the required length; for example, if the trees are to be set 40 feet apart each way on the square method, the stakes are placed every 40 feet on all sides of the field. The position of the intervening trees may be readily determined by sighting between the stakes on the opposite sides. On small areas the land may be marked off with a line connecting the opposite stakes, in both directions. The point of intersection of these lines indicates the position

of the trees. On larger areas the position of the trees is usually determined by sighting across the field or by the use of a modified corn-marker. Sometimes a plow is used to open up a furrow in both directions.

Before attempting to lay out a field that is irregular in outline, it must first be squared off in such a way that the rows running across the field will be at right-angles to the rows running the other direction. A base line running along a straight side of a field is first chosen. If there is no straight side, a straight line running along the longer side of the field may be established. At right-angles to this line and near each end, may be projected two other lines. On small areas this may be done with two straight edges and a carpenter's square, but on large tracts this method is not sufficiently accurate. The best and most reliable method is that described in Fig. 3. At the de-

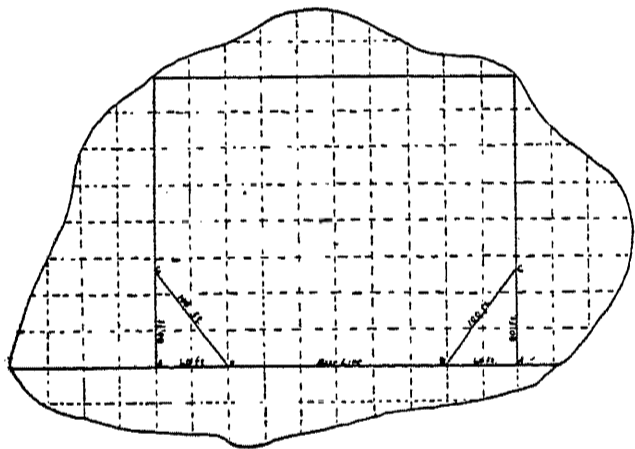

Fig. 3. Diagram Showing Method of Squaring Off an Irregular Field.

sired point (A) on the base line a stake is set, and exactly 60 feet from this on the same line another stake (B) is set. By stretching a string 80 feet long from the first stake (A) and another string 100 feet long from the second stake (B) and by bringing the two ends together at (C) the position of the third stake may be determined. Then the desired line is drawn from A through C to the other side of the field. The same operation is repeated near the other end of the field. The distance between the rows, one way, may be marked off on the projected lines and the distance between the rows, the other way may be indicated on the base line and also on the line

parallel to it on the opposite side of the field. The rows in both directions can be extended to the margin of the field.

On hilly lands it is often very difficult to get the trees lined up properly. In such cases, telephone wire is sometimes employed to stretch across the field. To indicate the position of the trees a smaller wire may be wound around and soldered to the larger one at the required distances. The telephone wire is stretched tightly and a stake set at every point indicated by the soldered wire. In the hollow places, where the wire is far above the ground, a plumb-bob may be necessary to find the exact position where the stake should be set. Twine, on account of its stretching character, is unsuitable to this purpose. The main point in measuring off uneven land, is in keeping the measuring line level. On steep hillsides, where cultivation is impracticable in any way, except parallel with the slope, the trees are often planted on terraces. These terraces are formed by leaving an unplowed strip of land along or between the rows. Where the slope is irregular it is very difficult and almost impossible to line up the trees properly and at the same time have the terraces follow the lines of trees. In such cases, the terraces, with a row to each terrace, are allowed to follow the contours of the slope, and the trees thus are arranged in curved, instead of straight rows. Where the slope is steep the terraces are made somewhat farther apart so that the trees will not be too close together. In view of the abundance of available land that is well suited to orcharding, it is seldom advisable to select such land that cannot be regularly laid out and conveniently cultivated.

When laying out the land for the quincunx system of planting, lines should be drawn midway between the other rows in both directions; that is, when the quincunx group forms a square 40x40 feet, the field must be marked out by lines 20 feet apart each way. The stakes for the trees of the even rows are set opposite the spaces of the odd rows.

The setting of the stakes for the hexagonal system seems to be somewhat more

difficult, but when once understood it is a very simple process. As may be seen from Plate II, Fig. 1, it does not differ materially from the laying out of an orchard on the rectangular plan. Lines are drawn across the field in both directions, but in all cases the distance between the lines running one way of the field, compared with that of the lines running the other way, is in the proportion of three to five. In laying out an orchard in which, for example, the trees are to be 36 feet apart each way, the distance between the lines running one way would be 18 feet (one-half of 36) and that between lines running the other way would be 30 feet. (Eighteen is to 30 as three is to five.) The stakes are then placed in the same manner as suggested for the quincunx system. The position of the fillers in the center of the diamond groups may also be located with this same system of lines. If more fillers are to be used, as previously suggested, lines nine feet apart one way, and fifteen feet apart the other way, will need to be drawn. A very simple method of laying out an orchard by this system, especially on uneven ground, consists in the use of a wire triangle, like that shown in Fig. 4. This triangle should be made

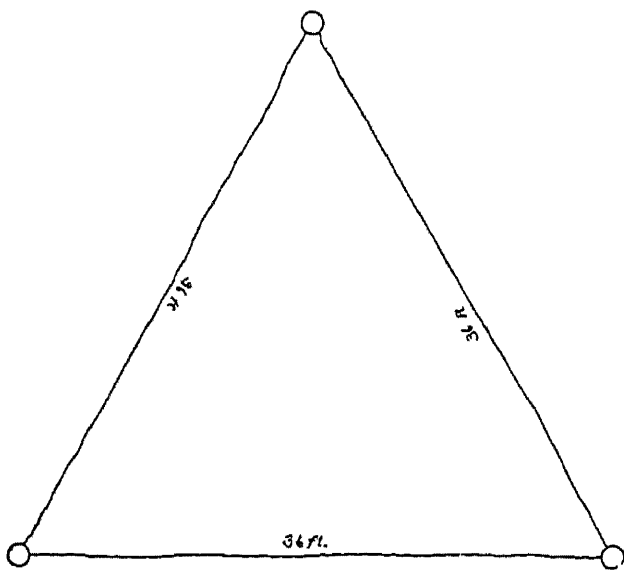

Fig. 4. A Wire Triangle Used in Laying Out An Orchard After the Hexagon System.

just the size of one-half the diamond formed by four trees; that is, each side of the triangle should represent the distance between the permanent trees. The wire should be connected at each angle by means of a ring. The triangle is car-

ried around by three people and the stakes located as shown on the margin of Fig. 3, Plate II. If the triangle is always kept tightly drawn and held on the level, there should be no trouble in correctly locating the stakes, even on very uneven ground.

C. D. JARVIS,
Storrs, Conn.

Rules for Various Methods

Rule for the Square Method—Multiply the distance in feet between the rows by the distance the plants are apart in rows, and the product will be the number of square feet for each plant or hill, which divided into the number of feet in an acre (43,560) will give the number of plants or trees to the acre.

Rule for the Equilateral Method—Divide the number required to the acre "square" method by the decimal .886. The result will be the number of plants required to the acre by this method. The meaning of the rule for the "square method" is that in dividing the number of square feet in one acre by the product of the distance in feet between the rows by the distances the plants are apart in rows, the quotient indicates the number of square blocks into which an acre is divided. Therefore, each block will have one tree placed in its center, which, of course, means that while the number of blocks are indicated by the rule the number of trees are also shown. In making a diagram of any plot of ground the number of squares will be indicated, and each square will have a tree in the center of it. This will give a turning place or strip on each side of the plot equal to one-half the distance between the tree rows.

The rule for the "equilateral method" may be explained by stating that each tree, instead of growing in a triangular plot is really placed in a parallelogram whose longest side is equal to the distance between rows in the "square" method, and whose shortest side is equal to .866 of this distance; or the ratio of the perpendicular drawn from an angle of an equilateral triangle to one of its sides. In making the tables decimals have been

omitted, and the nearest whole number used.

A Table of Distances

The question is often asked, How many trees or plants can be set per acre at a given distance apart? It will be found convenient to have at hand a table which will give the number without having to resort to a mathematical calculation, and to this end the table below has been made out, giving the number of trees or plants per acre planted according to the "square" and "triangular" methods.

Distance each way in feet	Square	Equilateral Triangle
1.....	43,560	50,300
2.....	10,890	12,474
3.....	4,840	5,889
4.....	2,722	3,143
5.....	1,742	2,011
6.....	1,210	1,397
7.....	888	1,025
8.....	680	785
9.....	537	620
10.....	435	502
11.....	360	416
12.....	302	348
13.....	258	298
14.....	222	256
15.....	193	222
16.....	170	196
17.....	151	174
18.....	134	154
19.....	120	140
20.....	109	125
21.....	99	114
22.....	90	104
23.....	82	94
24.....	75	87
25.....	70	80
26.....	64	74
27.....	60	70
28.....	55	64
29.....	51	60
30.....	48	56
31.....	45	52
32.....	42	49
33.....	40	46
34.....	38	43
35.....	35	41
36.....	33	38
37.....	31	36
38.....	30	35
39.....	28	33
40.....	27	31

P. J. O'Gara, Assistant Pathologist, Department of Agriculture.

A Good Planting Plan

After the ground has been thoroughly prepared the position of the trees should be determined. There are many ways of doing this work, and it depends some-

what upon the style adopted whether the square, quincunx, or hexagonal be used. The square is the most common method. By this method the rows are planted straight both ways across the field and the maximum distance between the trees may be had for the growing of other crops. This method also facilitates cultivation. The rows can be laid out by measuring off the head row all around the field and then plowing out a furrow both ways; the point where the furrows intersect will be the place for the tree. This is a simple method and one that is sometimes used very successfully. Another method is called the "stake" method and may be better understood from the following figure.

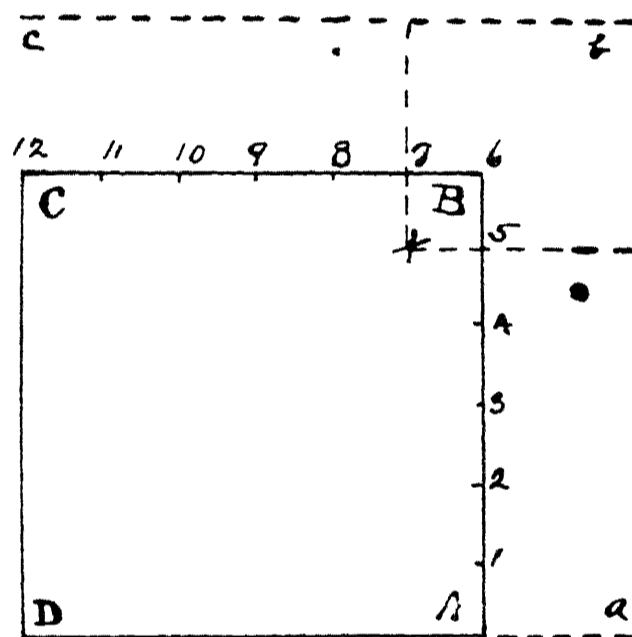

Fig. 1. A Good Planting Plan.

A, B, C and D represent the field to be planted. Begin at A and work up the lines AB and BC and at the proper distances at which the trees are to be planted mark the points 1, 2, 3, etc. Then go back 50 or 100 feet and measure off lines ab and bc parallel to lines AB and BC respectively. Begin at a and along lines ab and bc mark points at the same distances and corresponding to points 1, 2, 3, etc., along lines AB and BC. Be sure that points D, A, and a are in a straight line and that points D, C, and c are also in a straight line. Place stakes three to five feet in height at each of these points along the four lines. When ready to plant the trees start at any point inside the field ABCD. Stand erect

with a spade between your feet and sight in the direction of the rows of stakes, and if you are not standing at the point of intersection of the two lines move one way or the other until you find this point. The point of intersection of these lines is the place where the tree is to go. All the places for all of the trees may be found in the same manner and without having to measure any of the distances inside of the field. If the men are careful and always dig the hole right at the intersection of the two lines there will be no trouble in getting the trees in straight rows and at the proper distance. The planting can be started at any point in the field but it is better to begin at one of the sides near the rows of stakes and then work back. The point marked x is a good place to begin. This plan, with a few slight modifications, can be adopted for the quincunx or hexagonal styles.

FABIAN GARCIA,
Santa Fe, N. M.

Yoeman System

One of the easiest methods known to the writer is that called the Yoeman system. This consists in running a base line on one side of the proposed orchard and setting stakes at desired intervals for tree rows. These stakes, however, instead of being set where a tree is to be planted, are set some 10 to 20 feet beyond the last tree in the row. With the base line as a starting point the or-

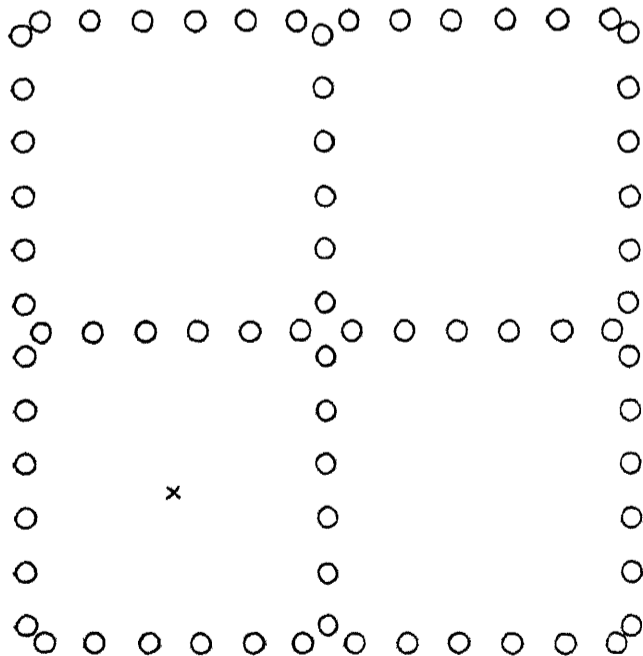

Fig. 1. Yoeman System.

chard site is enclosed on its four sides with a row of stakes which are set at similar distance from the last tree in the row to those of the base line. The stakes simply indicate the tree row in each direction. By running another set of stakes across the field and toward one end of it, in the opposite direction from that in which it is intended to furrow out, the field is ready for the plow. Using a heavy plow and a strong pair of horses and by going twice or more times in a furrow it is possible to furrow sufficiently deep so that little digging is necessary for the reception of the tree roots. By running a line of stakes through the center of the field in each direction, each of which is in line with the tree row in but one direction the field is ready for planting.

WILLIAM STUART,
Burlington, Vt

The Square System with Furrows

Where the ground is comparatively level and the area small, one of the simplest methods of laying out an orchard in squares is to set stakes along the boundary lines at opposite sides of the area to be planted and then use a marked wire for locating the position of each tree. Beginning on the side boundary of the tract, the first stake is set 25 feet from the end. Following this stake, other stakes are set successively at the distances the trees are to occupy, these stakes to be in line along the side boundary and extending the entire length of the field. The opposite side of the area is staked in like manner, beginning at the same end and staking in the same direction. After this a telephone wire which is long enough to reach across the field is secured. In one end of the wire a loop large enough to slip over the stakes is made. Twenty-five feet from this loop the wire is wrapped tightly with fine stove-wire over which a bit of bright red flannel is tied. Then, at distances the trees are to stand in the rows, other markings are made likewise along the telephone wire. By stretching the wire between opposite pairs of stakes the spot where each tree is to stand may be located.

Holes may be dug and trees set at once or stakes may be driven at the various marks.

Another system of marking off squares is to use a common turning plow. First of all stakes are placed around the field along the boundary lines similar to that described for the wire method except that the ends of the field are staked as well as the sides. The first stake in each line, on its respective side, is placed 25 feet from the true corner of the field. (See Fig. 1, p. 156. Yoeman system.) Furrows are made lengthwise and crosswise in line with opposite stakes, the position of the tree being located at the intersection of these furrows. With a good steady-walking team and a firm hand to hold the reins, rows may be made comparatively straight. However, it is necessary to align the trees by sighting in order to get straight rows. The greatest endorsement that this method has is that it greatly facilitates the digging of holes.

Still another method used is to locate stakes around the field as in the preceding case and then establish a row of stakes through the middle of the field each way in line with all side and end stakes respectively, but in such a manner that none of these stakes come where trees are to be set. After this, one man may stake out the orchard by himself for he has always two pairs of stakes running at right angles with each other with which to align himself for each row of trees in the orchard. Places for digging the holes for the trees may be readily located and the latter practice of using this system is very simple as no small stakes for individual trees are needed.

Hexagon System

Since an orchard laid out in hexagons has all of its trees equidistant, the first essential device for this work is a triangle, the length of each side of which is the desired distance between two rows of trees. Usually this triangle is constructed by the use of three pieces of flexible wire joined together at the three corners by rings one and one-half or two inches in diameter. (See Fig. 4, p. 154.) Measured from the middle of each ring, each side should cor-

respond exactly with the distance between the trees. A triangle constructed in this manner works very well on comparatively level ground but for sloping ground it is usually best to make the triangle of wood. Three well-seasoned 1x2-inch pine strips, each two inches shorter than the distance the trees are to be planted, are nailed firmly and braced together, forming an equilateral triangle. Care should be taken to have the sides of the face of this triangle on the same plane. At each corner of the triangle a pine board 6x6 inches is nailed, an inch hole is bored in each board in such a manner that measured from the center of the holes each side corresponds exactly with the distances the trees are to be planted.

How to Use Triangle

In using the triangle it is necessary to stake out one row by line at one side of the field, after which the triangle serves to locate all other stakes. Three men must carry the triangle, one at each ring. By placing two of the rings separately over two established stakes a third stake is established. This process is repeated until the entire field has been staked. Where it is desired to use hexagons on sloping or hilly ground a plumb-line and carpenter's level must be used in connection with the wooden triangle. Each time that the triangle is moved it is leveled and the plumb line hung at the corner where the ground is lowest. By this method the third stake may be exactly located in reference to the other stakes.

The Quincunx System and Device

The quincunx system is only a modification of the square system. In placing the rows of stakes at the side of the field it is necessary to place an additional stake midway between each two stakes described in the preliminary staking for squares. The marked wire described for laying out the squares has an addition mark or loop placed upon it, which measured from the loop previously described is half the distance that exists between the permanent trees. In other words, if the permanent trees are 40 feet apart, then this additional mark or loop would be 20 feet from the end of the loop.

When a "filler" row is to be staked this second loop is used and stakes or trees are set by the marks on the wire (except that the first one is skipped).

J. R. SHINN,
Moscow, Idaho.

PLAN AND DOUBLE PLANTING

Double planting is desirable because it enables us to make full use of the land while the orchard is young. By converting permanent squares into temporary quincunxes we secure an ideal plan for double planting; thus by planting our filler at the intersection of the diagonals of a 40-foot square, we get five trees in the square with the central tree standing about 28 feet from the permanent trees. This is an almost ideal distance for apple trees for the first 10 or 15 years of their bearing stage. This system of planting is not confined to the apple, however, but may be employed with other fruits as well. The practice of mixing different kinds of fruit trees in the same block is never advisable; the filler should always be of the same kind of fruit as the permanent trees; it is usually a different and quicker bearing variety.

Septuple Planting

In septuple planting the tree form equilateral triangles. The chief claim made for this method is that the trees are more evenly distributed than by any other—every tree being equidistant from the adjacent member of its group. Moreover, the trees in one row alternate with those of the next, which is an advantage in especially windy locations. Although this system does not lend itself readily to double planting it does not prohibit it. Plate I, Fig. 3, illustrates the different methods of using fillers in connection with permanent triangles. By introducing fillers in different ways, quite a variety of distances

may be secured. This also meets the condition of the home orchard inasmuch as we may approximate the ideal distances for the different kinds of fruit grown without modifying the general planting plan. For example, if apples are planted in permanent triangles, 40 feet apart, then by planting an additional tree in the center of each triangle we create a system of smaller triangles with trees standing approximately 23 feet apart, which is a very good distance for standard pears and sweet cherries. For plums, peaches and sour cherries, an additional tree may be planted between the corner 40-foot trees, thus converting the plan into triangles with trees standing only 20 feet apart; or trees may be set in the center of the 23-foot triangles, giving a distance of approximately 13 feet between trees. The 20-foot triangles reduce in the same manner approximately 11 feet. Thus almost any distance can be secured through these various methods of reducing the triangle.

Planting Plans

Many orchards are planted in too haphazard a way and without due regard to plan or alignment. A little care in laying out the rows will secure reasonably good alignment and a result that will be a source of gratification and pride to the planter throughout the life of the orchard.

Many individual plans have been advocated from time to time, but these fall readily into four systems of planting: viz., rectangular, square, triangular and irregular. The last system need not be noticed here since it is very seldom if ever justified.

The comparative merits of these different systems is of no little importance. On smooth and level land the preference of the grower will prove the main factor in deciding upon a plan for the orchard,

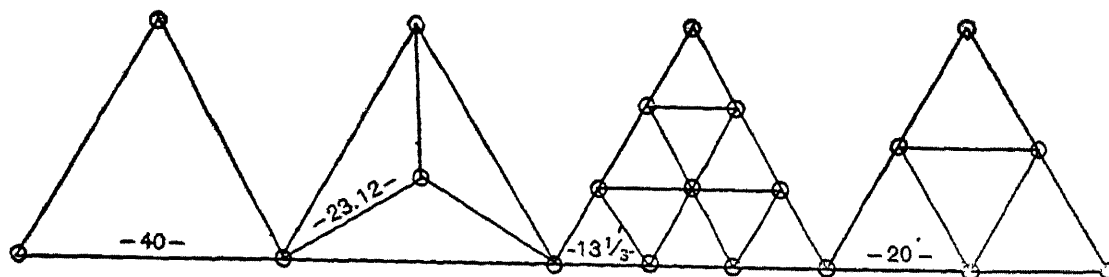

Fig. 1. Showing How Triangles May Be Reduced.

but this is not the case in hillside locations and particularly where double or filler planting is practiced. Here the advantages of a particular system is often sufficient to set aside individual preferences.

Rectangular Planting

This system is often used in connection with double planting, especially in cases where the filler tree is set in the row between the permanents. For example, trees may be set at first 20x34 feet and later upon the removal of every other row in one direction they are left in rectangles 34x40 feet. It is my opinion that none of the plans of this system that have been suggested have much to commend them since nothing is accomplished that could not also be secured by square planting and with a much more even distribution of the trees. On hillside orchards where cultivation must all be in one direction, plans falling under this type have some advantage but are out of the question if fillers are to be used.

Square Planting

Square planting including the quincunx plan is both simple and satisfactory. It is easy to lay out, convenient for cultivation and spraying, and gives a reasonably even distribution of trees. It is used by more growers than any other system and this is likely to continue to be the case. Typical square planting does not well adapt itself to the use of fillers if these are of the same kind of fruit as the permanent trees. This is true for the reason that halving the permanent distances must lead to too early crowding with the result that the fillers will have to be removed before they have yielded any considerable profit. The quincunx plan is not subject to this criticism. This after all is nothing less than square planting. By locating a filler in the center of the squares formed by the permanent trees, a system of smaller squares is produced but with the widest alleys running diagonal to the permanent rows. The quincunx method may be considered ideal for double planting on land that is level or only slightly sloping, but the fact that the system of alleys formed by the fillers and

permanents together are diagonal to the permanent rows and therefore leave the base line at an angle of 45 degrees renders the method unsuitable for hillsides. (See Plate I, Fig. 1, p. 161.)

The simple form of square planting is desirable on level land where the filling is with peach or other quick-growing fruit and, therefore, in the row between the permanent; it is also practicable on sloping land where this type of filling is practiced and where filling is not practiced at all.

Triangular, Hexagonal or Septuple Planting

This system of planting has many advocates. A great many advantages have been claimed for it, such, for instance, as more even distribution of trees with the consequent better opportunity for each tree to secure its proper share of food, space, light and air; also the fact that wide, wind-swept alleys are avoided. There is no doubt but that all of these items are advantages but their importance has been greatly overestimated. The best reason that can be given for the adoption of this system on level land is the personal preference of the planter. This will easily outweigh any other real or imaginary advantage in reaching a decision between triangular and square planting. The greatest advantage of this type of planting is one that I have not seen emphasized. It permits triple planting and at very satisfactory distances. Thus if the trees are first set 23 feet apart the removal of two rows of every three later on will leave the permanents 40 feet apart. Triple planting may be an advantage or a decided disadvantage, depending on local conditions. If fillers are set at the centers of triangles this will result in twice as many fillers as permanents and will give a choice of one of three varieties instead of one of two as in case of the quincunx system of fillers. In view of our uncertainty in regard to the most profitable variety for a given location, this extra row of fillers may be a very great advantage.

Another important advantage of this plan applies only to hillside planting. Filling can be employed in such cases if tri-

angular planting is adopted. This is true even where the land is quite steep, since if the base line of permanent trees is parallel in the main to the contour lines, then this will be true also of the permanent alleys while the alleys formed by all the trees taken together will leave the contour more properly the base line at an angle of only 30 degrees. This will make cultivation and hauling easy except on quite steep land where even a better plan than this can be adopted. The base line of either the smaller or larger (formed by permanent trees) system of triangles can be so laid out that it will intersect the main contour lines at an angle of 15 degrees, which will result in both the temporary and permanent alleys leaving the contour at an angle of only 15 degrees. This arrangement will result in an easy grade even on quite steep slopes. For the particular conditions just described, triangular planting has very decided advantage over all other types. In fact, there is no other system that has been devised which will satisfy the three conditions of even distribution, filler planting and planting on steep slopes. The decision between the different methods of planting under these conditions is not a matter of choice but one of necessity unless one is ready to disregard all questions of convenience in cultivating, spraying and harvesting. (See Plate I, Figs. 2 and 3, p. 161.)

Fitting the Plan to Special Conditions

We have seen above that special topographical features may have much to do with the selection of a planting plan, but thus far we have considered only plane surfaces—either level land or uniform slopes. Cove lands are often our very best orchard sites. These coves may be narrow or very broad. The main contour lines of two opposite slopes may, when projected to a common point, intersect each other at angles of approximately 60, 90 and 120 degrees or they may be practically parallel and the head of the cove roughly assumes the form of a half circle. The reverse conditions will be met when planting on two opposite sides and around the ends of ridges.

The ridge may be narrow and sharply pointed or it may be broad with end well rounded. It may be practicable to plant the whole slope or only a part of it. In fact, a great variety of conditions will be met in actual practice. Can orchard plans be devised to fit these variable topographical features? Such plan must result in rows parallel (approximately) to the contour lines and yet secure a uniform distance between the trees with regular and even distribution.

By combining square and triangular planting in the same plan the grower will usually be able to fit his planting to almost any type of surface which may be met. It is of course obvious that minor irregularities cannot be taken into account. We will now attempt to show how this can be done by discussing the main types likely to occur.

1. *Given a case where the head of a cove or the end of a ridge represents a hollowed or rounded surface and the contour lines of the opposite slopes approach so that when projected to the point of meeting they will form an angle of 120 degrees.*

The plan of planting that will best fit this type of surface may be described as follows: A system of equilateral triangles are arranged on the point of the ridge or at the head of the cove so as to form a group constituting one large equilateral triangle. The figure will have apex at upper side of field for ridge and at the lower side of field for cove planting. The triangular group thus serves as a wedge to turn the course of the two wings of the plan. Perpendicular lines are projected from the trees on the two sides of this figure and these will locate the rows for the square planting. (See Plate I, Fig. 4, p. 161.) It is only necessary to measure off the proper distances on these lines to locate the position of the trees belonging to the square planting. The plan then becomes two systems of squares (forming either square or rectangular figures) connected by a system of small triangles constituting one large equilateral triangle. It is obvious then that the main rows of the two wings will form with each other an angle of 120 degrees.

The only difficulty met in this combination plan is due to the fact that the continuous alleys are reduced in width as they cross the triangular planting, for the obvious reason that the altitude of a triangle is less than its sides. This

objection can be avoided by substituting for the equilateral triangle a slightly different figure. In the upper apex of the triangle is considered the center of a circle and a system of arcs are inscribed about this point which subtend an angle

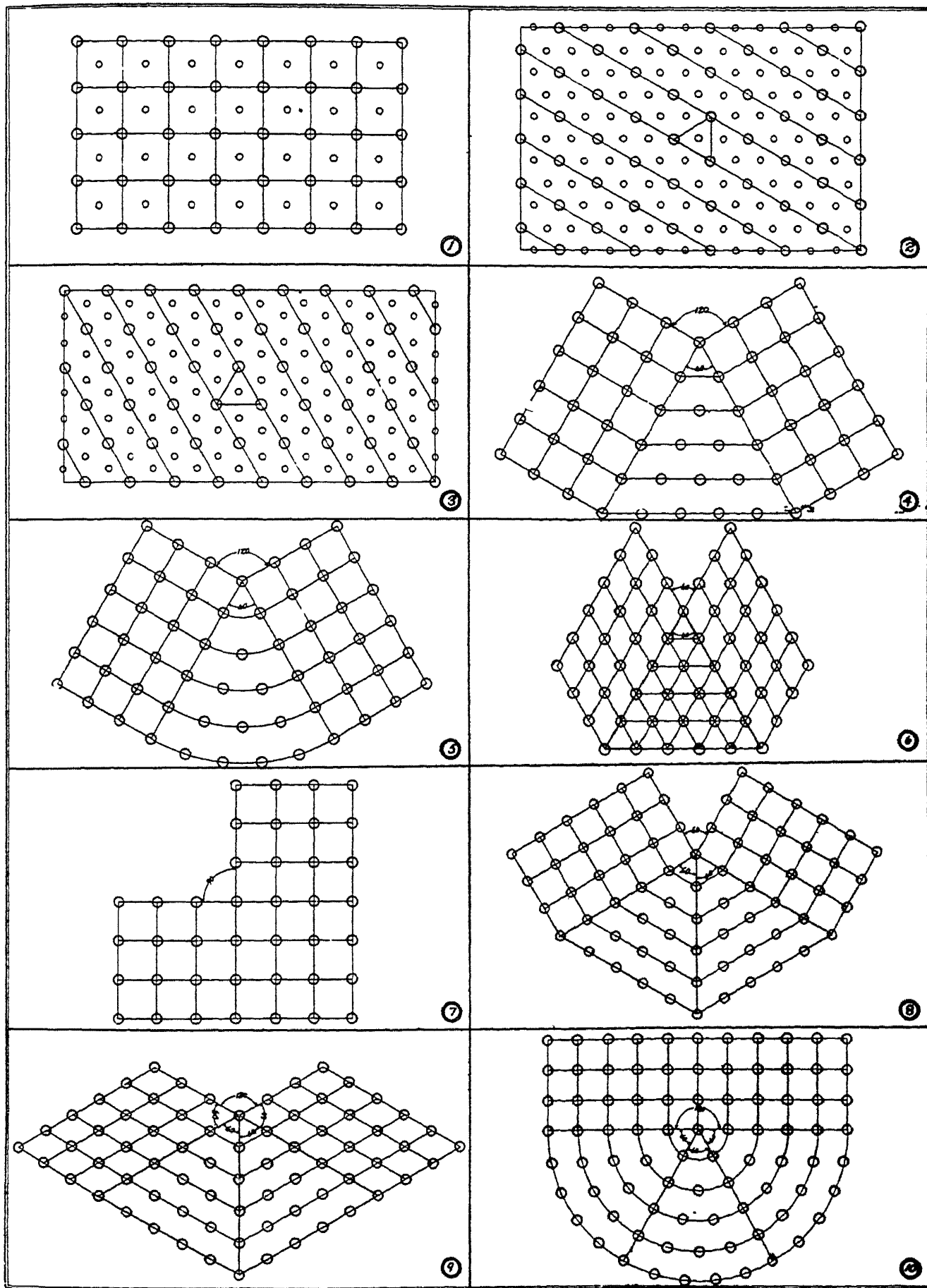

Plate I.

of 60 degrees and are the same distance apart as the distance between the trees; then the trees can be located in alternate fashion on these curved lines so as to secure a gradual shift from the triangular to square type of planting. This results in a uniform width of alleys, a smoother and more regular arrangement of rows. The rows are also more nearly parallel to the contour. While the trees are not as evenly distributed as before (requiring slightly more land) yet this difference is unimportant. The method of laying out this figure is not difficult. (See Plate I, Fig. 5, p. 161.) Pure triangular planting will also meet this case. Four equilateral triangles with a common apex will leave an angle of 90 degrees. (See Plate I, Fig. 9, p. 161.)

2. *Given a case where the contour lines of the two opposite and approaching slopes meet at an angle of approximately 90 degrees.*

Square planting so as to form an "L" meets the requirements of this type of surface. (See Plate I, Fig. 7, p. 161.)

3. *Given a case where the intersecting contour lines form an angle of only 60 degrees.*

This will be approximated in case of narrow ridges or coves. Such types of surface conformation are frequently met. Two triangular figures such as were described under No. 1 are used for the triangular planting. They are arranged with a common base line and with apices opposite. This common base line serves as a meridian and runs directly up the slope. Perpendiculars are projected as before from the trees on the upper side of this double figure for ridge planting and from the lower side for cove planting. The angle formed by the main rows of the two wings form an angle of 60 degrees. (See Plate I, Fig. 8, p. 161.)

This same type of surface can be solidly in triangles so arranged as to form a winged figure with the same angle, but the turn is more abrupt. (See Plate I Fig. 6, p. 161.)

4. Only one more type of surface exists, viz., *where the contour of opposite slopes whether ridge or cove formation are practically parallel except at the end*

of ridge or head of cove, the point of juncture being effected by a half circular slope (either concave or convex).

Here three triangular systems or figures with a common apex furnishes a half hexagon and will therefore give a full turn to the rows. It is better, however, as in case No. 1, to describe a system of half circles and plant alternately on these lines than to plant in perfect triangles. The contour lines will thus be approximated and there will be a uniform width to the alleys as well as a uniform curvature of rows. The distribution of trees is sufficiently even to meet all practical requirements; in fact, they are more evenly distributed than in square planting. (See Plate I, Fig. 10, p. 161.)

At first blush these combination plans appear to be too fanciful to be of practical value, but on comparing them with many types of surface formation, and a great variety in topography which may be found in this state, it will be found that one or the other of the plans described or a combination of these plans may be made to fit almost any type of surface to be found. If due regard is given by the grower to planting plans there is no reason why roads should follow all kinds of grades through the orchard. Too little attention has been paid to this subject in the past which has resulted in great inconvenience in cultivating and spraying the orchard and in harvesting the fruit crop.

Planting Table
Number of Trees Per Acre

Distance apart of trees each way in feet	Square Method	Triangular Method
12	302	348
15	193	222
18	134	154
20	109	125
25	69	79
30	48	55
35	35	40
40	27	31

Planting Rules

1. To determine the number of trees required per acre by the square method at a given distance apart. The number of square feet per acre (43,560) divided by the square of the distance will give the correct number.

2. To determine the number of trees required per acre for rectangular method. Divide the number of square feet per acre by the product of the two sides.

3. To determine the number of trees required per acre for triangular or hexagonal method. Find the number of trees for the square method (same distance) and divide this number by the decimal number .866.

4. To find the width of alleys in triangular (equilateral) planting. Divide the distance between trees or side of triangle by the decimal number .866.

5. In triangular planting where fillers are located at center of triangle, the distance between permanent trees may be found by multiplying the original distance by the number 1.732.

6. In quincunx planting to find distance between permanent trees after thinning multiply the original distance by 1.42.

7. To determine the number of trees removed by thinning in quincunx planting multiply original number by one-half; in square plantings and triangular planting filled both directions in the row multiply original number by three-fourths; equilateral triangular planting filled in center of permanent triangles multiply the original number by two-thirds.

H. L. PRICE,

Virginia Polytechnic School, Blacksburg, Va.

Trees Generally Too Close

The consensus of opinion is, that generally trees are planted too close together. Those who have given this subject much thought are pretty well agreed that the proper distance for large trees of 20 or 30 years of age is about two rods or 33 feet. In some parts of the country trees are of much slower growth than in others. It probably takes a tree twice as long to reach a given size in the northeastern part of the United States as it does farther south and on the Pacific Coast. Thirty-three feet apart allows for 40 trees per acre. The principal objection to this plan is that it is almost a generation before the trees will need all of the space that is given to them if

there are only 40 trees to the acre, and in the meantime there is much land and labor wasted that might in some way be utilized to considerable advantage. With this in view the plan of planting "fillers" between the rows and cross rows has been adopted, so that instead of having 40 trees per acre there are 160 trees per acre, and instead of being two rods apart they are one rod apart.

The purpose is to cut out these fillers at some period during the growth of the trees when they begin to crowd each other.

Kinds of Fillers to Use

If this plan is adopted the question is What kinds and varieties of fruits shall be used as fillers, with the object of sacrificing them when the permanent trees require the room? Very often peaches are selected, because the peach tree is a rapid grower and early bearer; it is also a short-lived tree and will in some cases have passed its highest usefulness before the apple trees need the ground.

The pear is more nearly related to the apple than the peach, and needs more nearly the same treatment, requires the same spraying and can be grown in apple orchards without any particular inconvenience. However, it is not so vigorous a grower as the peach and will not yield as large returns for the first few years.

Some will plant Wagener apples as fillers, because they bear heavily, bear early and trees are shaped much like the pear. Others will plant small fruits, such as strawberries, raspberries, blackberries, etc., because they can be so pruned as not to interfere with spraying or cultivation. Some discard fillers and raise vegetables. If this method is adopted, the land should generally be mulched or manured in order to put back into the soil the substances taken out by the crops.

It has been argued by Van Reman and Deman and others that the best method is to plant nothing but apple trees in an apple orchard, plant them 20 feet apart, and when they begin to crowd each other cut them out diagonally.

Thus we have a variety of opinions, each possessing some merit, and each the

best adapted to some persons under some circumstances.

See Article on "INTERCROPPING."

GRANVILLE LOWTHER

Plan and Pollination

For convenience in harvesting it seems desirable to plant trees of the same varieties near together, but on account of many varieties being self-sterile it is not advisable to plant more than two or three rows of a single variety in one block. A self-sterile variety is one whose pollen will not properly fertilize the flowers of the same variety. Trees whose blossoms have not been properly fertilized usually fail to set fruit, but sometimes produce more or less fruit of a gnarly and worthless character. The pollen from a self-sterile variety may be depended upon to fertilize the blossoms of any other variety that blooms at the same time. It is difficult to say which varieties are self-sterile and which are self-fertile, for the subject has not yet been sufficiently investigated. There seems to be a difference of opinion among those who have made a study of the subject, for some claim that certain varieties are self-sterile while others believe them to be self-fertile. It is probable that a variety may be self-sterile in one locality and self-fertile in another. The varieties that are generally recorded as self-sterile and that should not be planted alone are: Red Astrachan, Yellow Bellflower, Chenango, Gravenstein, Maiden Blush, Tompkins King, Primate, Rambo, Gano, Tolman, Esopus Spitzenburg, York Imperial, Wine-sap, Roxbury Russet, Golden Russet and Northern Spy. The varieties that are generally believed to be self-fertile are: Oldenburg, Yellow Transparent, Fall-water, Grimes, Jonathan, Rome Beauty, Rhode Island Greening, and Baldwin. These conclusions are the result of limited observations, and until more reliable information is available, the best practice is to avoid large blocks of any single variety and to plant varieties of the same blooming period in adjoining rows.

C. D. JARVIS,
Storrs, Conn.

Avoid Block Planting

Varieties of fruit should not be planted in orchards in large solid blocks. Some of the most productive varieties are not readily fertilized with their own pollen. Such varieties would be unproductive unless situated so that their blossoms could be pollinated by other varieties blooming at the same time. Old orchards teach their lessons along this line. A commercial orchard under observation recently consisted of four varieties, in solid blocks, in the following order: Baldwin, Golden Russet, Roxbury Russet, and Spy. The Baldwin is a self-fertilizing variety, and whenever there was any fruit in the orchard it could always be found on the Baldwins. The Golden Russets were laden with fruit on alternate years. The Roxbury Russets were pretty generally productive. The Spy block was uniformly unproductive, except for a couple of rows next the Russets, which bore well whenever the orchard bloomed. Many good varieties of fruit are unproductive because they are so situated that their blossoms cannot be pollinated from neighboring varieties. Instead of planting varieties in solid blocks they should be planted in alternating rows. This may make a little more trouble at packing time, but there will almost invariably be more to pack.

W. N. HUTT,
Raleigh, N. C.

SETTING THE TREES

Size of Holes

The size of the hole in which to plant the trees varies according to the soil and root system of the trees to be planted. We hear a great deal about digging large holes for trees. On the whole it is not necessary to dig large holes if the soil has been properly prepared and it is a good tree soil. For the average size apple tree on good tree soil the holes need not be more than 12 to 18 inches square and about the same depth. If the trees are to be planted in a soil that is not a tree soil then the hole must be made larger. If the soil is almost pure sand or gravel the hole ought to be made quite large and then partially filled with

good earth in which the roots may grow the first year. On the other hand if the soil is very heavy and hard the same treatment is recommended. But, on the whole, if the soil is not suited to trees better not plant any. Orchardists very frequently inquire as to the advisability of putting manure in the bottom of the hole. This practice is not advisable. If manure is to be used on the young trees it had better be used as a surface mulch.

FABIAN GARCIA,
Santa Fe, N. M.

TIME OF PLANTING

Much difference of opinion exists between the best authorities as to the season for planting apple trees. Late fall planting is advocated by some, while others are equally certain that early spring planting is better. The chief reasons advanced by the former are that roots of trees set in the fall become thoroughly established in the soil, and that all cut surfaces on the roots become calloused during the winter, which results in new roots pushing out early in the spring. On the other hand, dry falls and dry winters will prove fatal to many fall-set trees, and the stand will therefore be imperfect. Since Idaho very often experiences these latter conditions, early spring planting may be regarded as the safer rule. Moreover, if trees are "heeled in" in the fall the roots will be thoroughly calloused by early spring, thus affording such trees one of the main benefits derived from fall planting. Undoubtedly spring planting should be the rule for Idaho orchardists.

J. R. SHINN,
Moscow, Idaho.

Time of Planting in New England

In this part of the country spring planting is usually preferred. The chief, and probably the only advantage, in fall planting is in getting the work out of the way. Trees for planting should not be taken from the nursery row till the leaves have fallen, and this is usually so late that the weather is not suitable for planting. If the soil should be dry, as is often the case in the fall, the trees are likely to dry out and be injured during the winter.

As previously noted, it is advisable to purchase trees in the fall so as to get a better assortment and to have them ready for planting in the spring as soon as the weather is favorable. If this suggestion is followed and if soil and weather conditions are favorable in the fall after the stock arrives, the trees may be safely and profitably planted. If left till spring the planting should be done as soon as the ground can be conveniently worked.

C. D. JARVIS,
Storrs, Conn.

Southern Conditions

The question as to the best time to plant is governed somewhat by latitudes. In southern latitudes late fall or the early part of the winter may be safe for planting. But in most of the states early spring is considered the better time. Fall planting has the objection against it that the roots of a tree do not take hold of the ground sufficiently to supply enough moisture to maintain a healthy active circulation of the sap which is required to prevent shriveling of the branches during winter's extreme cold and exhaustive evaporation from drying winds.

G. B. BUCKETT,
Washington, D. C.

Southwest

The time of setting out trees varies. There are many different opinions on the subject, some claiming the fall is the best time while others favor the spring. It is to be remembered that a tree can be planted at any time during its dormant period. It may be set out in the fall, winter or spring. Fall planted trees sometimes do as well as winter or spring planted trees. It is a difficult thing to recommend any set rule for the time of planting trees. Each time has its advantages and disadvantages. As a rule the local conditions decide which is the best time for planting. One of the reasons why fall and winter planting is not practiced more than it is in cold and dry climates is on account of the loss of moisture from the tree during this time. The roots being cut off and not having started to grow do not supply the tree with any moisture during the fall and winter. As a rule the roots will not begin to grow

and supply any moisture to the tree until the spring. Evaporation from the tree is going on all the time. The moisture given off by the tree has to be replaced by the roots. If the roots have not been established they cannot supply this moisture which is being evaporated. The longer this condition exists the more the tree will suffer. The roots of spring planted trees do not lie in the ground as long as those of fall planted trees before they begin to grow. The drier the fall and the winter the greater will be the evaporation and the more likely the tree is to suffer. On the other hand in mild climates fall planted trees very frequently start small roots which may supply moisture to the tree during the winter. Where trees do that fall planting is better, but where they do not spring planting is preferred. In the Mesilla valley in Southern New Mexico fall planted trees frequently start a few roots soon after being transplanted. Taking everything into consideration spring planting is better for New Mexico conditions.

FABIAN GARCIA,
Santa Fe, N. M.

Upper Mississippi Valley

For the Upper Mississippi valley, spring is the preferable time for planting. Trees which have been disturbed in the fall by transplanting are more subject to root-killing the following winter. The work should be done early in the spring in order that the roots may have time to become re-established before the hot and often dry weather of July and August. In planting all mutilated roots should be cut back and any diseased portion cut away. If the root system appears to be unhealthy the tree should be discarded, as it is a mistake to plant anything but strong, healthy specimens.

A. T. ERWIN,
Ames, Iowa.

Lower Snake River Valley

In the fall and winter of 1910-11 the Lewiston-Clarkston Improvement Company planted at Clarkston, Wash., 1,000 acres of apple trees. Mr. W. B. Lanham, horticulturist for the company, states:

"We started planting the first of December and finished about the first of

April, planting whenever the weather would permit. The time of transplanting seemed to make quite a difference in the growth the trees made this season. The first planted made at least twice the growth of those set out last, with a gradual graduation between."

Conditions were practically the same for all plantings except that December planting was made after a wet November. More rain fell during that month than during the five months succeeding. The precipitation for November was 3.51 inches, between 0.3 inch and 0.75 inch for the next five months and 1.56 inches in May. No water was used in planting and the trees were not irrigated later. The ground froze that winter to a depth of about two feet.—Ed.

Fall or Spring Planting (Michigan)

The advisability of fall or spring planting depends upon several conditions. Fall planting has the advantage over spring planting in that the trees become firmly established in the soil before winter sets in, and are able to start growth in the spring before the ground can be marked and put into condition for planting. This is important because the trees get a good growth in the early part of the season, before the summer droughts occur. On the other hand, there is more or less danger from winter injury during a severe winter or from drying out of the trees if the winter is long or dry. Fall planting is much more successful with the hardy apples and pears than it is with the tender plums, cherries and peaches. In Michigan it is seldom safe to plant peaches, sweet cherries or apricots in the fall.

The convenience of the season will determine in a majority of cases whether or not the planting shall be done in the fall or spring. Very often the rush of spring work induces the grower to hurry his planting, or to do it carelessly, and as a result a poor stand is secured, with crooked rows. Others have large crops to harvest in the fall, and would find it more convenient to do the planting in the spring. If there is any doubt as to the best time to plant, let it be done in the spring, and as early as the ground can be gotten into proper condition.

O. K. WHITE,
Field Agent in Horticulture, Michigan Agricultural College Experiment Station, East Lansing, Mich.

Setting the Trees

The land is now supposed to be prepared, and the next step is digging the holes into which the trees are to be set. These should be dug large enough and deep enough so that the roots are not crowded, curved or doubled up in planting and so that the tree will be a little deeper below the surface than when it left the nursery. It seems to us a little better to dig all the holes before any of the trees are set. Many pursue a different plan, but the reason we give for this is that when the trees are taken from the pit where they have been heeled in during the winter or to await setting, they should not be exposed to the air for any considerable period of time, lest the drying process stop the circulation of sap and the trees be less likely to live, but they should be set as soon as possible after they are taken out of the pit. The roots at all times should be kept moist. In fact, the most successful tree planters

we have known kept the roots in a barrel or tank of water which they hauled along beside the rows and as soon as the tree was taken from the water it was set in the earth and a bucket of water poured around the roots, then the loose, dry earth was thrown over it and pressed down closely at the top.

GRANVILLE LOWTHER

TREE LOCATING DEVICES

Planting Board

After an orchard has been staked it is important that some device be used that will serve to locate the trunk of the tree in the same place occupied by the stake. For this purpose one of two devices is used by orchard planters. The first and most common consists of a board one inch thick, six inches wide and six feet long. An inch hole is bored in the center and one at each end at equal distances from the center. To complete the construction it is only necessary to mark out a strip



Fig. 1. Method of Keeping Young Trees in Barrels of Water to Prevent Drying While Being Planted.



Fig. 1. Planting Board in Position Before the Hole is Dug.
Purdue Experiment Station.



Fig. 2. Planting Board in Use. Purdue Experiment Station.

an inch wide on the side of the board that will include the hole made in the middle and then saw out this piece. Stakes, 12 to 14 inches long, are provided which will easily slip through the end holes. In using this device, the groove in the center of the board is placed tightly against the stake standing where the tree is to go, a stake is pushed into the ground through each of the holes at the end, then the bar is removed. After the hole has been dug it is only necessary to replace the board over the end stakes and bring the trunk of the tree to occupy the same position as that occupied by the stake. After the hole is practically filled the bar is again brought into service and the tree placed in its exact position.

Triangle

The second common device employed for locating trees is a triangle made by nailing firmly together three strips each one-half inch thick, two inches wide and six feet long, allowing a projection of three inches of the strips at the corners of the

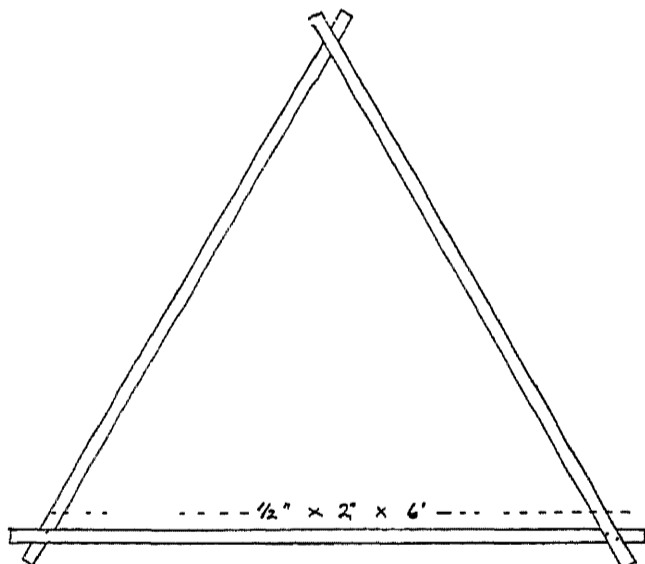

Fig. 3. Triangle for Locating Trees.

triangle thus formed. In use, one projecting corner of the triangle is placed firmly against the stake standing where the tree is to go and a stake driven in each of the other two corners, the triangle is removed, the hole dug and the tree brought into exact position similarly to that given for the bar.

For Large Areas

Where large areas are to be planted it is often wise to have two or four of

these tree locating devices all constructed according to the same specifications. Two men proceed to locate the temporary stakes and to dig the holes while two others follow, with the same kind of locating device, setting the trees.

Aside from the fact that the tree locaters are serviceable in putting the trees in their exact positions, they also give the planter a good idea of the depth at which the trees are being set. Without their use, trees may easily be placed in the holes and the earth filled in about them before it is discovered that the planting has been too shallow.

J. R. SHINN,
Moscow, Idaho.

Protecting the Roots

When the ground is ready for planting, the trees are hauled to the land, distributed at convenient distances, and heeled-in in bunches. The roots should not be exposed to the air more than is absolutely necessary.

Puddling

Some growers believe in "puddling" the trees before they are taken to the field. This operation consists in dipping the roots in a semi-liquid made of clay and water. The clay forms a coating over the roots and prevents their drying out. It is claimed that fewer failures follow the planting of puddled trees than trees that have not been so treated. If the planting is done during drying weather, this treatment may prove to be an advantage, but where ordinary care is exercised in protecting the roots from the sun and wind, there is little need for such treatment. The trees for immediate planting may be distributed by using a barrel on a stone boat. If the barrel is kept about half full of water and the trees left in it until needed for planting, there will be no danger of their dying out.

Method of Planting

The work of planting may be most expeditiously done with four men, or two men and two boys. One man operates the planting-board, another digs the holes, a third brings the trees and holds them in position, while the fourth man shovels in the soil. Boys may be used to operate the

planting-board and hold the trees. The man or boy who operates the planting-board after adjusting the stakes for the first hole, goes on to the second, adjusts a second pair of guide-stakes, returns with the board to the first hole, allows the other boy to locate the tree, and then he pulls up the guide-stakes and takes them with the board to the third tree-stake. While he is back at the first tree the hole is being dug at the second position and by the time he sets the guide-stakes for the third position it will be time to locate the tree in the second position. The boy who holds the tree while it is being planted gives it a shake with an up-and-down motion to get the soil scattered among the roots, and when about half the soil is in, he firms it with his feet. He then goes after another tree and leaves the man who does the filling in to give the final treading and to leave a loose layer of soil on the surface. The holes are dug just large enough to accommodate the roots. Under the best conditions, that is, where there are few stones and where there is nothing to impede the progress of the workmen another boy may be advantageously used to bring the trees as they are required. If two gangs are working on different rows, one boy may supply trees to both gangs.

The important point about planting is to get fine moist soil firmly packed around the roots so as to avoid large air spaces. No fertilizer should be put into the holes when the tree is planted. It is not well to plant when the soil is wet, for handling it in this condition spoils its physical properties, and a baked soil is the result.

Depth

Apple trees should be planted at about the same depth as they stood in the nursery row or probably one or two inches deeper.

C. D. JARVIS,
Storrs, Conn.

Four-Man Squad

Four men make an effective squad. One man prunes and distributes the trees. Another places the tree in proper position by sighting on the stakes in both direc-

tions, and compacts the soil around the roots of the trees as it is filled in by the two shovellers. Their duties are to remove whatever soil may be necessary for the reception of the tree roots and to shovel the soil back in around the tree. The surface soil should be placed in contact with the roots rather than the subsoil. Given a man who can sight accurately, the alignment of the trees in both directions will be close enough for all practical purposes.

WILLIAM STUART,
Burlington, Vt

Depth

How deep to plant a tree is another question that comes up every once in a while. Many apple growers claim that the trees planted should not be any deeper than they were in the nursery row. Others pay no attention to this idea. According to results at the station along this line there is no material difference in the growth of trees that are planted at the depth that they were in the nursery row and trees that have been planted for two or three or even six inches deeper. In a general way we will say that trees may be planted two or three inches deeper than they were in the nursery row if desired.

Irrigation

Immediately after the trees have been transplanted they should be irrigated. If the trees have been planted in the small trench, as suggested below, they can be irrigated through it. If they have not been so transplanted they will have to be flooded. Where water is expensive and where it is desirable not to irrigate the middles between the trees the best way is to plow a trench about a foot or two wide and plant the trees in the trench and irrigate them from it. This method we find very economical and very easy. It is a good idea to examine the trees about a week after they have been irrigated the first time, as sometimes the soil settles quite a good deal and some of the roots may be exposed to the air.

FABIAN GARCIA,
Santa Fe, N. M.

TREATMENT AT PLANTING TIME

The treatment of apple trees at planting time has a very great influence upon their future welfare. Many orchard planters set trees in their permanent position without applying the least amount of rational treatment to them. For example, trees are planted in the orchard in the same condition as they are received from the nursery. At the close of the first season, the owner is much troubled to learn the reason for the poor growth, and in many instances the utter failure of his trees.

Prune the Roots

The amount of root-surface that trees have when they leave the nursery row is usually about half as great as they possessed normally. Further than this, it is always advisable to thin out all crowding and interlacing roots and to cut away all broken ends of those remaining. In the South a very severe system of root pruning is practiced, known as the String-

fellow method, but this method is not practicable in the North. Nevertheless, apple trees require a certain amount of root pruning before they are planted in order to get the best results. The opportune time to do this pruning is in the fall, as stated elsewhere, but where the trees do not arrive until spring, root pruning should be administered before the trees are planted. However, root pruning done in the fall, saves labor at planting time.

Prune the Top

Since the tops and roots of trees are mutually dependent, there is a nice balance between these parts as they exist normally; consequently it appears reasonable to believe that where a portion of the roots has been removed, a similar amount of top should also be pruned away. In fact, even a greater amount of the top should be removed than that removed from the roots since the latter must become adjusted to their new quarters before their activities begin, while the former experience no radical difference in this respect. With yearling trees, the necessary pruning for establishing low-head trees will reduce the top sufficiently. It is best to postpone the pruning of the tops until the trees have been set, at which time they are cut down within 18 or 20 inches of the ground.

The trees should be conveniently located for the planters before planting operations begin. Some orchardists practice distributing and "heeling-in" the trees in bunches near the place where they are needed. Other men puddle the trees in a tub which is placed on a low sled or stone-boat and drawn by a horse from place to place as the trees are needed. The puddle is made of loamy soil mixed with water to a slushy consistency. Heavy clay soils must not be used for making puddles. The use of this puddling practice constitutes one of the safest and most satisfactory methods of handling trees in the field for the roots are not exposed to the air at all.

Holes for apple trees must be large enough to accommodate all the roots and deep enough to allow the tree to set



Fig. 1. Upper Figure, A Good Root System for a Nursery Tree; Unpruned. Lower Figure, Same Root-System Shortened in for Setting. More Severe Pruning Would Not be Injurious. —Purdue Station.

three or four inches deeper than it stood in the nursery. It is believed that the best results are secured by setting dwarf trees so that the union between the bud and the stock is four or five inches below the surface.

Common Error

The common error committed by most tree planters is to plant too shallow. Deep planting tends to develop a deeper rooting system; besides it affords a better anchorage for the young tree.

Size of Hole for Hard Soil

The size of a hole in hard soil should be greater than that of a hole dug in loose soil that is not underlaid with a hard impervious subsoil. Holes for trees in such hard soils should be especially large. In some instances it is advisable to use giant powder to break up this hard soil. Mr. B. F. Hurst of Boise, Idaho, recommends that a hole be dug to a depth of two feet, and in the center of this hole another hole is bored to an additional depth of five feet. Giant powder is then exploded in the bottom of the bored hole. The method is described by Mr. Hurst as follows: "Use two sticks of giant powder for each hole. Drop one stick down in the hole. Loosen, at one end, the paper around the other stick of dynamite. At this end insert a sharp peg the size of the cap to be used. Attach the fuse to the cap and place the cap in the end of the powder. If there is water in the hole cover the cap with wagon grease, then draw the paper, and tie it around the string. Place this stick in the hole where the first stick was dropped, leaving the fuse about six feet long. The hole may be filled with water, or fine earth, but must not be tamped. Touch the match to the fuse. It is probably superfluous to say that the operator should immediately remove to a considerable distance from the hole!

When using dynamite great care must be observed, for it is extremely dangerous in the hands of the inexperienced. It is very essential that the stick, to which the cap has been applied, be lowered gently into the hole or a premature explosion may result. The safer practice

in using this explosive is to employ experienced help. In removing the dirt from the hole, that taken from the top-most six inches should be placed on one side while that taken from the lower depths should be placed in a separate pile. The reason for this is that the surface soil is richer, containing more available plant food than the subsoil, and is therefore better adapted for placing in immediate contact with the roots. The bottom of the hole should be thoroughly loosened by several thrusts of the spade after which some of the surface soil is thrown in before the tree enters the hole.

Filling the Hole

After the tree has been placed in its exact position, by means of a tree locator or by sighting, the roots are spread out evenly in all directions and then the hole is filled. The first dirt put into the hole should be the rich soil from the surface. This should be worked tightly under and between the roots by using the fingers. Slightly moving the tree up and down will aid in getting the soil under the roots. The hole is then filled half full of surface soil and tramped down firmly; after this the hole is filled to the top with the other soil and again tramped. A few shovelfuls of loose dirt or a few forkfuls of manure thrown about the tree to prevent the loss of moisture, completes the operation.

Manuring the Hole

The question is very often asked regarding the advisability of placing manure in the bottom of the hole. A forkful of fine, well-rotted manure placed in the bottom of the hole may often prove beneficial, but coarse manure should never be used in this manner because it will heat and scald the roots. Spreading manure on the surface about the tree is generally regarded as the better practice.

Lean Towards Wind

Where the wind blows strongly from the southwest, and west, as it does in many localities of Idaho, unless some windbreak exists, it is very important that the tree be set so that it points strongly against the prevailing wind.

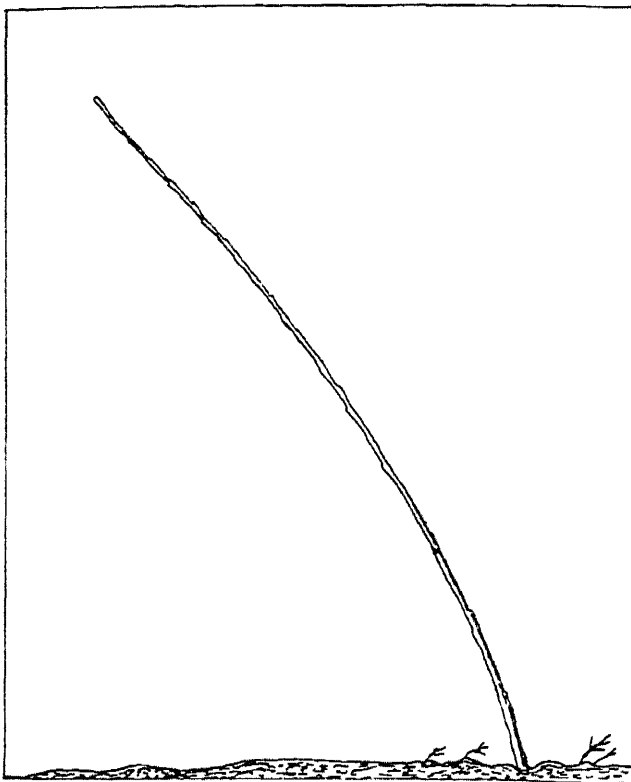

Fig 2. Where Winds Are Strong, Lean the Tree Towards the Prevailing Wind.

Many trees that have been set on orchard sites exposed to the prevailing winds illustrate the need of using this precautionary measure, for where they were set straight they are now found to lean greatly away from the wind.

J. R. SHINN,
Moscow, Idaho.

Root Pruning

In digging the tree at the nursery all of the roots are cut off considerably. Many of those that remain are more or less bruised. At the time of transplanting all of these bruised roots must be cut off. In placing the tree in the hole it is usually advised that the roots be spread out flat. Then put some soil in and raise the tree a little. In humid sections where irrigation is not practiced it is advisable to pack the soil very thoroughly around the roots. In our irrigated regions we do not consider this so very necessary for the reason that immediately after the trees are transplanted they are irrigated. If there are any air spaces left between the soil and the roots the irrigation water will pack the soil around the roots.

To meet the loss of roots due to transplanting the tree it is necessary to remove part of its top. The amount to be cut depends on how high we wish to start

the scaffold limbs. This must be decided by the grower himself. As a rule for New Mexico conditions we recommend low headed trees. For such trees the scaffold limbs ought to start out about 12 to 18 inches from the ground. Do not neglect cutting back all newly transplanted trees.

FABIAN GARCIA,
Santa Fe, N. M.

Shade the Trunk

Most nursery trees are grown close together, some six to eight inches apart in the rows. The tendency is to produce slender stems, and unbalanced tops. The nurseryman is forced to produce his trees as cheaply as possible. Aside from the result of crowding mentioned, the trees shade the trunks of their neighbors considerably. The tendency is to cause a softer and more tender growth. The sudden exposure when such trees are planted out singly for the orchard must be trying to the tree. This is one reason why the trunks of newly set orchard trees should have their stems protected immediately by the strips of wood veneer now much used. These may be had of all basket factories at about \$4.50 to \$6 per 1,000. They should be wired on loosely and left till they rot off. When the tree gets large its own branches will shade the trunk, and they will then be inured to their new position. There is some advantage, it will be seen, in one-year trees, *since they have suffered less by shading and crowding each other in the nursery row*, besides being cheaper and coming out with less mutilation of the root system. Young trees are commonly considered preferable because in digging there is less mutilation of the roots. The writer is convinced that the point above suggested is quite as important, if not more so. It seems hitherto to have escaped the attention of writers dealing with this subject. In setting the trees all mutilated roots should be cut off smoothly by a cut from below outward. If the ground has been properly prepared, the hole need be only sufficient to receive the roots in a natural position, placing the tree as a rule as deep as it stood in the nursery. Few

planters appreciate the importance of working the soil in among the roots next the axis. The fingers answer the requirements of the case better than any implement, or the foot. There should be no cavities among the roots, and provided the soil is sufficiently dry to work it can scarcely be pressed too firmly about the roots. Firmness of the soil about the roots encourages the movement of capillary water towards the tree.

In land with compact subsoils the digging of large holes to be filled with loose rich earth, as is sometimes practiced in small plantings, is to be avoided. Holes in such lands become receptacles for seep water. Better not plant such land until tilled, or if used the holes should be filled with the soil removed. I have seen trees planted, principally for home use, in such land where the soil was built up slightly, making a shallow mound where the tree is to stand. The roots of the tree are then set on the slight mound. The object is plain. Ordinarily we should use for orchards only lands which will admit of level culture.

ERNEST WALKER,
Fayetteville, Ark.

First Summer

The orchardist should be sure to keep his trees growing vigorously during the first summer, as this is the most vital period in the history of an orchard. It is highly essential that the trees have a good start before mid-summer, in sections where irrigation is not practiced, for summer drouth is likely to prove fatal to trees of low vigor and slow growth. Thorough tillage is imperative for the best success, whether the orchard be irrigated or not. Conservation of moisture in the soil and aeration of the soil are the main results to be attained by this cultivating. To this end any crop grown in the orchard the first summer should be one that requires frequent cultivating. Such crops as small fruits, potatoes, tomatoes, melons, etc., are therefore, well adapted to young orchards, while the grain and pasture or meadow crops should be avoided. Tillage should be continued until about the first of August when it

is well to sow some leguminous cover crop, such as hairy vetch or Canada field peas. Sown at this time or a little later, these crops will make sufficient growth to form a mat over the surface of the ground; and while making this growth they will aid materially in ripening the wood for the following winter. Moreover, such crops will prevent the washing and leaching of soils during winter and when plowed under the following spring will add as much organic and fertilizing matter to the soil as a small coating of manure would furnish.

The stubs which the orchardist has left after planting soon become covered with shoots issuing from every bud. The proper treatment of these shoots is an important consideration. Some rub off all the shoots as they appear, excepting four or five which are left for the scaffold limbs. A better practice consists in rubbing off only the lowermost shoots, leaving about ten shoots to form leaves and to grow throughout the year. In allowing more leaf-area a greater growth of root system is promoted since the two parts are mutually dependent. The thinning out and the selection of the scaffold limbs is a task for the following spring.

Diseases and Insects

Diseases and insects are likely to make their visitation upon the young orchard during the first year. The orchardist must be ever watchful for their appearance and be ready to shorten their stay to the minimum. Anthracnose on the trunk and shoots and scab on the leaves are likely to be the most serious diseases; while the apple borer, the green aphid and the San Jose scale are most prominent insects. Timely application of the best preventives and remedies for these pests is the only safeguard. Careful and frequent observations is the rule for success in dealing with such opponents.

J. R. SHINN,
Moscow, Idaho.

Pruning First Year

This is perhaps the most important of any year during the life of a tree because it determines where the head of the tree shall begin to form. We advocate low

heading, and therefore the first year in pruning would cut off the top not more than one foot above the surface of the ground. In fact, we have thought six inches is better than one foot, but many regard this an extreme. Our reasons for low heading were discovered by accident. Rabbits having girdled several trees during the winter, the owner of the orchard had to decide between cutting off the tops of the trees near the ground or rooting them up altogether. These trees are now 18 years old. They are the healthiest, largest, most prolific bearers in the orchard. This is not confined to one variety, but is true of all the varieties in this orchard. We have observed other orchards where similar conditions prevailed, and in every case we have been confirmed in the conclusion that low heading is decidedly preferable.

GRANVILLE LOWTHER

DISTANCES TO PLANT

One of the most common mistakes made by orchardists is that of planting too many trees to the acre. "Short lived trees" is a very general complaint, and overcrowding is one of the direct causes of it.

Moisture

A number of important factors should be considered in determining the number of trees per acre. Moisture plays an important part in plant growth. Most varieties of apples are from 85 to 90 per cent water. This fact has an important bearing especially for semi-arid regions. When we recall that each inch of rainfall means about 120 tons of water per acre the amount is significant, particularly in a country where the annual rainfall is approaching a minimum supply for the maintenance of tree growth. It is therefore evident that with a given annual rainfall per acre, the closer the planting the less the water supply for each tree.

Distance and Yield

Too close planting is one of the most serious hindrances to the successful production of high grade fruit. A large share of the apple orchards, especially

those set from 15 to 40 years ago, suffer from this mistake, which deprives the trees of air and sunlight, two of the cheapest and most essential factors in successful fruit growing. The writer has seen many orchards in which the trees were planted from 16 to 20 feet apart, the branches interlacing, forming a complete network over the whole orchard area, thereby restricting sun and air exposure to the top of the floor-like array of branches. In other words, these trees planted 20 feet apart simply had an area of 400 square feet of exposure to sunlight and air. If instead of four trees with an area of 1,600 square feet exposed to sun and air, but one tree grew which did not meet its neighbors by about two feet, this well developed tree would have over twice the area exposed to sun and air on top and side alike or somewhere in the vicinity of 3,500 square feet; and in addition from 20 to 25 per cent of the soil would be open to the sunlight.

Investigations at the New York Station* indicate that

Trees set 30x30 feet gave a four-year average of 186 bushels per acre.

Trees set 31x31 to 35x35 feet gave a four-year average of 222 bushels per acre.

Trees set 36x36 to 40x40 feet gave a four-year average of 229 bushels per acre.

Varieties

Varieties attaining the size of Northern Spy, Rhode Island Greening and Baldwin should be set from 35 to 40 feet apart each way. Some growers are even setting these varieties 40 by 50 feet apart. McIntosh, Fameuse and similar-sized trees may be planted from 32 to 35 feet apart. Yellow Transparent, Tetofsky and other similar upright growers may be planted somewhat closer. Distance-determining factors other than that of variety are the character of the soil, the severity of the climate, and the closeness of pruning. A strong soil will of course

* New York (Cornell) Station, Bulletin 226, p. 301 (1905).

cause a greater wood development and must be taken into account.

WILLIAM STUART,
Burlington, Vt.

Vermont Experiment Station, Bulletin 141,
1909.

Distance and Climate

The distance at which to plant apple trees varies with the variety and with the climatic and soil conditions. Apple trees in states where they attain large size and are long-lived are planted from 35 to 40 feet apart. In New Mexico and especially in the warmer valleys the apple tree is not very long-lived nor does it attain a very large size. Most of the orchards now growing in New Mexico are from 25 to 30 feet between the trees. Because of the fact that orchards must be sprayed economically, trees ought to be planted at least from 30 to 35 feet apart.

FABIAN GARCIA,
Santa Fe, N. M.

Thirty to Forty Feet Best

A decision as to the proper distance apart to set trees varies with different planters. Some plant 16 by 32 feet—that is, the trees 16 feet apart in rows 32 feet apart. The object of this method is to obtain a crop from the trees until they begin to interfere with each other, when ever alternate tree in the row is cut out, leaving the trees in the entire orchard at a distance of 32 feet each way. The trees to be cut out should be early-bearing, short-lived varieties. This system has the advantage of more fully utilizing the land for fruit production until the thinning out becomes necessary.

Other planters adopt a distance between trees of 20, 24, or 30 feet apart each way, claiming that by the time the trees interfere with each other they will have finished their growth and the orchard will begin to decline. But it is generally conceded that 32 to 40 feet is the preferred standard distance. If the distance of 40 feet each way is adopted, it will afford ample space between the rows for growing any crop which requires cultivation, such as corn, beans, potatoes, etc. Such cultivation is highly important and necessary

for the maintenance of moisture in the soil and for the health and vigor of the trees. This distance will afford free circulation of air and abundance of sunlight, both of which are essential to the growing of well-developed and highly-colored fruit. Small grain should never be grown among fruit trees, especially when the orchard is young.

G. B. BRACKETT,
Washington, D. C.

Close Planting and Fertilization

Closely connected with the subject of the fertilization of orchard lands, is the subject of close planting. Close setting is the rule, and the use of peach trees as "fillers"—a practice to be deprecated—is common. Various distances for planting are advocated by different growers, and in use. There has hitherto been a tendency to decrease the distance rather than increase it. The method of close planting, so common in connection with early and heavy bearing, calls for especial attention to the matter of fertilization of orchard lands. Such lands are commonly fertile in the beginning, but it is only a matter of a few years when trees under the conditions mentioned begin to feel the need of additional plant food. If our orchards are shorter-lived than trees in other regions, the practice of close planting of fruitful kinds, coupled with neglect of cultivation, and of proper fertilization of the land, offers an adequate explanation. Some large and successful orchardists advocate and practice close planting, but they give proportionate attention to the matter of maintaining the fertility of the land.

J. H. Hale, so widely known in the horticultural world, plants peach trees 13x13 feet and makes it pay—but as Van Deman remarks,* "he feeds them like a lot of pigs."

In close planting, early bearing kinds like Duchess, Missouri Pippin, Wealthy, and Wagener are frequently used as "fillers," the idea being to cut out the superfluous trees before they do harm to the permanent ones, but, as practical growers

* H. E. Van Deman. "Plans for Orchard Planting," Rural New Yorker, March 6-13, 1897.

know, few ever carry out their good resolves.

An orchardist who has 900 acres in trees at Cedar Gap, near Springfield, Mo., * writing on the subject of close planting after 15 years' experience, has the following to say:

"Now that the time for tree planting has arrived, I desire to call attention to a mistake that is often made by beginners in the Ozark region. I refer to close planting. Apple trees in good land should never be planted closer than 30x30 feet apart, and on fairly good land 25x25 feet apart. On poor soil that will not produce 20 bushels of corn to the acre apple trees are unprofitable. * * * These distances give room for cultivation, spraying and gathering; produce longer lived trees, better fruit and more money in the long run."

There are advantages in close planting in the row north and south as the trees tend to shade and protect each other; but after some years the roots interlock, and even with the best cultivation it is well nigh impossible to maintain the moisture needed in time of drouth.

ERNEST WALKER,
Fayetteville, Ark.

Spraying

Close planting prevents the proper spraying of the orchard. Thorough spraying has come to be recognized as one of the first requisites of successful orcharding. The rows should be a sufficient distance apart to admit of ready access to trees from every side. The exact distance apart may vary somewhat according to the varieties planted and the lay of the ground, but in general 50 mature apple trees per acre, approximately 30 feet apart, is ample. Any number in excess of this means overcrowding and weakened trees.

A. T. ERWIN,
G. R. BLISS,
Ames, Iowa

Space Versus Soil

The space to give apple trees in an orchard varies according to the soil and variety. On good soil the strong growing sorts require about 40 feet in each direc-

tion, at maturity. The space between may be occupied for the first 10 or 20 years with 'fillers'

W. J. GREEN,
Wooster, Ohio.

Distance and Variety

The proper distance apart for planting depends altogether upon the ultimate size of the tree, which will vary with the variety, the soil, the location, and the kind of treatment. With good treatment, full grown trees of the smaller growing varieties, like Wagener, Wealthy and Yellow Transparent, for example, may not require more than 20 to 25 feet, while those of the larger growing sorts like Baldwin, Rhode Island Greening or Roxbury Russet, may require from 35 to 40 feet. When located on the heavier soils, especially at the base of a hill, trees usually grow much larger, and sometimes attain a spread of 50 feet.

The investigations of the Cornell Experiment Station based upon the behavior of hundreds of orchards, reveal the fact that within certain limits, the wider the spacing the greater the yield. It would seem advisable either to space the trees the maximum width or decidedly closer. The reason for this is that in a very closely planted orchard, half of the trees may be removed when they begin to crowd, leaving the remainder about the right distance apart, while in an orchard where the trees are only moderately close, the removal of every alternate tree would leave the remaining trees too far apart.

C. D. JARVIS,
Storrs, Conn.

Soil Determines Distance

The distance apart at which to space the trees should be governed largely by the character of the soil upon which the orchard is to be located. Where the soil is thin, as in many of the hilly sections of Ohio, 25x25 feet apart is a good distance. On richer ground the distance should be not less than 35x35 feet either way, or the equivalent. Some growers plant 25x30, while still others who have had experience with apple orchards on very fertile soil recommend not less space than 40 feet between trees either way.

* Louis Erb, Memphis, Tenn., in Practical Fruit Grower, Vol. VIII, No. 141 (1902), p. 5.

Close Planting and Quality of Fruit

Close planting results in an abundant supply of apple scab and other troubles, by bringing about a dense growth and excluding sunshine and ventilation. Any cultural method which tends to secure good ventilation, a dry atmosphere, and an abundance of sunshine does much towards holding these foes in check. The spray pump has come to stay and is a valuable tool, yet prevention is always better than cure.

Close planting gives protection when the trees are young. A better plan is to provide protection by a windbreak and low headed trees.

Color in fruit is almost as important as quality. The absolute necessity of an abundance of sunshine for the development of highly colored fruit is an axiom. Every boy is conversant with the fact that the most highly colored apples are to be found on the long outer twigs which have an advantage over their fellows in the amount of sunshine they receive. Too many of our fruit plantations represent forest rather than orchard conditions. On account of over-planting the tops interlap, resulting in a heavy shade and a moist atmosphere, and making high coloring in fruit an impossibility.

In the case of the apple, the color is more than skin deep. Color formation is accompanied by the flesh development within. In recent cold storage experiments conducted at the Ohio Experiment Station it was clearly demonstrated that, other things being equal, highly colored fruit has an advantage in keeping quality. There is also a direct relationship between the color and the percentage of scald.

F. H. BALLOU,
Wooster, Ohio.

PROBABLE LOSS OF TREES FROM PLANTING

The questions sometimes arise, "What is the probable loss in setting young trees? What per cent will fail to grow?"

This depends so much upon the nature of the conditions and the manner of doing the work that it is difficult to estimate. The writer was interested in an

orchard of 80 acres on which there were planted 3,500 trees, or an average of 47 $\frac{1}{4}$ trees per acre. The next spring we replaced 33 trees, making two less than one per cent of loss. The next spring we set 20 acres and 990 trees. They were set in newly-plowed alfalfa soil, the land not quite so well leveled, making it a little more difficult to irrigate, and as a result it was not so well watered and we had to replant 36 trees or nearly four per cent. We have known 25 per cent of the trees planted to die, and in a few extreme cases nearly all of them have died. This, however, is almost wholly on account of neglect, and is preventable. It is not necessary to lose one per cent, provided care is exercised in the selection of good stock, the roots kept moist, the ground properly prepared, and the planting well done.

GRANVILLE LOWTHER

WINDBREAKS

Columbia River Valley

While objections are often made to the use of windbreaks they are very advantageous wherever orchards, vineyards, small fruits, or truck crops are exposed to strong winds. Especially is this true where the soil is sandy and subject to drifting. Since the prevailing winds are from the west and southwest, the principal windbreaks should extend north and south or approximately at right angles to the direction of the wind.

Some of the more important points to be remembered in the selection of trees for windbreaks are the following: Effec-



Fig. 1. Windbreak Greatly Needed. Only by the most judicious pruning can these trees be balanced, and then only with great difficulty. Staking would have helped many of these trees.—Oregon Experiment Station.

tiveness in checking the velocity of the wind, value as timber, longevity, difficulty in starting, inclination to harbor orchard pests, habits of encroachment upon the areas protected, etc. Few trees meet all of these requirements. When a single variety is planted few trees are as effective as the poplars, especially the Lombardy poplar. They develop rapidly, branch from the ground up, and make a very efficient windbreak when planted close together. A very effective windbreak can be made by planting the black locust and the Russian artemisia together in the same row. The locust should be set about eight feet apart in the row. The timber of the locust makes valuable fence posts.

The artemisia is a shrubby plant that is started from 7-inch cuttings set 12 to 15 inches apart. It should attain a height of 4 or 5 feet the first year and 8 or 9 feet the second year. Low windbreaks can be made by planting the artemisia alone. A good hedge of this plant is growing on the experiment farm of the State College at Pullman, Wash., from which cuttings may be obtained.

The European larch instead of the black locust may be used with the artemisia. It will not spread and encroach upon the protected area as much as the locust or the poplars. Its timber also makes good fence posts.

Fig. 2 illustrates how temporary windbreaks may be made from sagebrush.

Byron Hunter, Bureau Plant Industry, Circ. 60.

Windbreaks for Mississippi Valley

In the mountain regions among the hills or foothills an orchard site would generally be selected with reference to protection from the winds by the contour of the land. For instance, if the prevailing winds are from the west an eastern slope would be protected, and from this view would be preferable to a western slope. If this is not practicable or convenient then the trees are often set at an angle of about 45 degrees, slanting toward the wind so that the blowing will not cause the trees to lean, but to assume an upright position, and so that its center of gravity will not be far from the line of the tap root. The orchard needs protection either by the hills about it or by means of windbreaks.

In the prairie regions such as we find in the Mississippi valley there are no hills and the orchards are protected by rows of trees or groves sometimes planted so as to shelter both the house and the orchard.

For such situations the following instructions given by A. T. Erwin of Ames, Iowa, are applicable:

"In prairie regions a windbreak is of



Fig. 2. Asparagus Beds on Sandy Soil Near Kennewick, Washington, Protected by Sagebrush Windbreaks. When the land was cleared low posts were set upon the tops of which a large smooth wire was stretched. Instead of burning the sagebrush, it was hung on the wire to serve as a temporary windbreak.

great value to the orchardist. Windbreaks shield the trees from the hot drying winds of summer, reduce the percentage of wind-falls, and assist in holding the snow in winter. The location of the windbreak should be determined by local conditions, though generally speaking our most destructive winds are during the growing season, and are the hot dry winds from the south and west. It is inadvisable to plant a windbreak on more than two sides of the orchard.

"The windbreaks may consist of either deciduous or evergreen trees. If deciduous trees are used, they may be planted in rows about eight feet apart and the trees four feet apart in the row, with the idea of thinning as they become larger. In this way a supply of timber and post material can be secured at the same time. The catalpa, diamond willow, and green ash are desirable deciduous trees for this purpose. The soft maple is also widely used though it is a gross feeder and should be given more room and also placed at a greater distance from the last row of apple trees than the kinds we have named.

"Among the evergreens, the white pine, Austrian pine, white spruce, and Norway spruce are widely planted. It is often advantageous to plant two rows of evergreens, using one row of quick growers such as Norway spruce or Scotch pine, and the second row of slower growing, long-lived kinds, such as the white pine. The windbreaks should be cultivated with a corn cultivator for the first two or three years after planting, as the annual growth can be greatly increased thereby. The red cedar should not be planted as an evergreen about the orchard, since it is a host for one stage of apple rust or cedar-apple-fungus, which is very troublesome in some orchards. For further information regarding different species of evergreens and their characteristics, we refer the reader to Bulletin 90 of the Iowa Experiment Station, which may be obtained upon request.

"If possible the windbreak should be started one or two years before the apple trees are planted. If the white pine is used it should be placed on the lee side,

using some more hardy variety, such as the Austrian pine, on the windward side. The windbreak should not be planted closer than 40 feet from the last row of apple trees. Many of our orchardists have made the serious mistake of planting evergreens close to the apple trees, and as a result the last row of fruit trees is overshadowed and practically worthless."

The Windbreak for Idaho

Where orchard sites are particularly exposed, windbreaks are especially advantageous. They stop the force of the wind so that the trees are allowed to attain their normal shape instead of having their limbs on the southwest and west sides forced to grow up through the center of the trees. They prevent the loss of apples which autumn winds shake down at a time when their value is greatest. They protect the buds of winter from drying out and losing their vitality.

Evergreen

Evergreen trees furnish ideal windbreaks since the winds are broken at all seasons. Such barriers stop the sweep of winter winds as well as winds occurring during the growing season. The Norway spruce, because it possesses these qualifications, is unsurpassed as a tree for windbreaks.

Lombardy

The Lombardy poplar is used in some sections but its roots are so extensive and its tops afford protection for only part of the season.

The windbreak should be planted in advance of the apple trees in order that it may afford protection from the start. Spruces should be set ten feet apart with the rows at least 40 feet from the nearest apple trees. Since most of the strong winds of Idaho come from the west and southwest, a windbreak should occupy a position around the south and west sides of the orchard. In wind-swept places a bank of evergreens, made in this manner halfway around the orchard, should be regarded as a necessary part of good orcharding. This wall of evergreen will also add a delightful variety to the landscape in all seasons.

J. R. SHINN,
Moscow, Idaho.

VARIETIES OF APPLES TO PLANT

In selecting varieties it is impossible to give advice except in a general way. The conditions of climate and soil and the circumstances of the orchardist are so different that each one must determine for himself, after a few general facts and principles are presented. In the first place, much depends on whether the planter wants a family or commercial orchard. If he is planting a family orchard, he will probably select one or more trees of the very earliest varieties adapted to his section of the country, and will choose varieties maturing later, so that the fruit will be fit for use each month until late in the autumn, when he will pick and store his winter fruit. If he is planting a commercial orchard he may largely disregard his own taste and that of his family and select only those varieties that are heavy and regular annual bearers, good keepers, good shippers, and those that bring high prices in the market. In doing this he is deferring to the demands of the market and is planting those varieties for which the public will pay the highest price. It is money he wants, and for this reason he does not seek to gratify his own peculiarities of taste. He will, therefore, consult the markets and learn the average price paid for certain varieties.

Local conditions often affect the choice of varieties. For instance, the Wagener apple is well adapted to the uplands of Eastern Washington, but it is not the best adapted to the lower levels of the irrigated sections of that state, and produced under these conditions would be considered a third grade apple. The Wolf River may be good for certain sections of the country; we see it recommended for planting in nearly all of the districts of the central and northern sections of the United States; but in the lower elevations, especially in the irrigated sections, it is not considered a high grade apple—it is too large, punky and lacks flavor. The Rome Beauty and the Delicious are among the very best apples in the higher elevations of Central Washington, but it is questionable whether as products of the lower valleys they

will be so highly regarded. However, the Rome Beauty has been before the public long enough to establish itself, and to make a reputation which places it among the higher grades of apples. The Delicious has since its introduction to the markets brought higher prices than any other apple, but is one of the new varieties which may or may not hold its place for a long period of time in competition with others. There are varieties that have a wide range of adaptability. The Winesap, Jonathan, Esopus Spitzenburg, Grimes Golden, Northern Spy, Gravenstein, Rome Beauty, Newtown Spitzenburg and Tompkins King are among the varieties that adapt themselves to varied conditions from the Atlantic to the Pacific, and for the most part to the northern and central sections of the United States. There are a few exceptions to this rule. The Yellow Newtown is not so adaptable. It is one of the best apples in the world's markets; it reaches a high state of perfection in Albemarle county, Virginia, where it bears the name of Albemarle Pippin. It is also one of the best apples for Washington and Oregon, but is not so variously adaptable as the other varieties named.

About the safest way for the planter is to take the advice of the professor of horticulture in the nearest experiment station, and of his neighbors, in order to know what results have been obtained by those who have tested the varieties of that section. For commercial orcharding, it is argued by men of large experience, that it is better to plant but few varieties. One man planted 100 acres and chose Spitzenburgs, Newtowns and Winesaps; another similarly located chose Winesaps, Jonathans and Rome Beauty. Here is a difference of opinion between two experienced and educated men. It is generally conceded that it is better to have more than one variety because the cross-pollination improves the quality and quantity of fruit. Considering the value of an orchard of good commercial fruit, and considering the time it takes to bring it into bearing, the importance of wise selections is evident, but

how to advise, involves so many questions that it is a difficult undertaking. Under the heading of *Districts*, this section, the lists of fruits recommended by the American Pomological Society are given, and while none will agree with them on every point, when all things are considered it is the best list published and perhaps the best that can, with present information, be adopted.

Cost of Production and Value of Good Varieties

The selection of good varieties, and the production of the best qualities of whatever varieties are chosen, cannot be overestimated in a desire for large net profits. It costs almost as much to grow poor varieties and poor grades as it does to grow the best, and the results are vastly different. Suppose, when the orchard comes into bearing, the land it occupies is valued at \$1,000 per acre. Interest on this amount at 7 per cent is \$70 per acre, on 10 acres, \$700. We will suppose the average cost of irrigating water, in sections where irrigation is practiced, to be \$1.50 per acre, or for 10 acres, \$15. We will estimate the cost of food for team, depreciation of the value of team, wear and tear of machinery, harness, etc., at \$25 per acre, for 10 acres, \$250. This makes a total per acre of \$96.50, or for 10 acres, \$965. Under fair treatment, this orchard should yield 650 boxes per acre, or 6,500 boxes. This estimate is high except in case of large trees. The cost as thus far estimated, will be approximately 14 cents (\$0.14) per box. Now, suppose we add the cost of spraying, labor, irrigating, picking, assorting, packing, box-materials, boxing and hauling to market. According to a consensus of opinion gathered from a wide range of inquiries, we will place these expenses at 47 cents (\$0.47) per box. This, added to the 16 cents per box, which includes interest on land, water, taxes, etc., places the cost of producing a box of apples at 61 cents (\$0.61). Generally, the interest on land, taxes and labor of the owner are not counted, because it is argued they furnish the owner a home, a profitable place to work, and steady em-

ployment. We estimate it here, however, because in our purpose of showing the difference between the growing of good or poor varieties, it occupies a logical place, and the estimate would not be complete without it. See tables on cost of producing apples for further estimates.

Suppose, then, an orchardist grows varieties of apples that sell at \$1.00 per box; he has a net profit of 39 cents per box, or \$2,535 on ten acres of 6,500 boxes. He has had interest on the money invested, has had pay for his labor, a place to live and work and \$2,405. This, of course, would yield him an income sufficient to enable him to live, to avoid the trouble of moving, paying rent, and to pay him for responsibility, care, long hours of labor which he often performs, and unforeseen emergencies. All these are important items, and are as much as many expect, because many come up to the close of life with nothing saved. Suppose, however, that instead of growing varieties or grades that sell at \$1.00 per box, he grows fruit that will sell at \$1.50 per box; he has in addition to the estimates we have already made, 50 cents per box net profit, or on one acre \$325; on 10 acres, \$3,250. This, added to the profits of \$2,535, already obtained under the system that produced apples at \$1.00 per box, equals on ten acres \$5,785. The difference between the two profits of \$2,535 and of \$5,785, is a difference of choice of varieties, and proper management.

We would not overlook the emphasis upon "proper management," because even if the best varieties are selected, and they are not properly adapted to soil conditions, to frost conditions, sprayed, pruned or thinned, they may result in disappointment. If not sprayed for scale, or codling moth, 90 per cent of the crop may be unmarketable. If not properly thinned, it may be of good quality; but be too small to bring high prices on the market. We may have as many boxes of unthinned small fruit as we would of thinned well-developed fruit; but our small fruit will bring a small price, while our well developed fruit will bring a good price.

The cry of "over-production" of fruits need strike terror to none except those growing poor grades; for the world's best things are never over-done.

Further, whoever puts a poor grade or a poor quality of fruits on the markets is just insofar as his product is capable of influencing the markets, destroying the demand for fruits. For instance, whoever eats a Spitzenburg, Yellow Newtown or Delicious, in the proper season of the ripening of these varieties, will want more apples. Whoever eats a Ben Davis or Missouri Pippin will feel less desire for fruit, for these varieties do not so strongly appeal to the average taste. The Arkansas Black is for beauty the best apple we grow, but for taste it is inferior to several other varieties, and is almost always sold before its proper period of ripening.

The figures of profits above given are based upon the growing of the best varieties and average market conditions.

GRANVILLE LOWTHER

For Eastern Washington

Recommendations by State Experiment Station

The following is the list of fruits recommended by the horticulturist of the

state agricultural experiment station at Pullman for planting in that part of the state lying east of the Cascade mountains. In cases where the varieties to be recommended for planting in the irrigated valleys are different from those best adapted to the non-irrigated uplands, this is indicated. The letters (E), (M) and (L) indicate that the varieties ripen early, mid-season, or late, respectively. The lists do not include all varieties that might be planted, but are those which experiments and actual orchard practice have shown to be desirable for general planting. The varieties are arranged alphabetically in each case

Apples—(For the irrigated valleys), Delicious (L), Duchess (M), Gravenstein (M), Grimes Golden (L), Jonathan (L), King (M), Rome Beauty (L), Spitzenburg (L), White Winter Pearmain (L), Winesap (L), Winter Banana (L), Yellow Newtown (L), Yellow Transparent (E); (for upland orchards), Delicious (L), Duchess (M), Gano (L), Gravenstein (M), Jonathan (L), King (M), Rome Beauty (L), Wagener (L), White Winter Pearmain (L), Wealthy (M), Winter Banana (L), Yellow Transparent (E), York Imperial (L).

Best Sellers

Best sellers reported in order of importance by Yakima valley nurseries.

Winesap	Delicious	Stayman Winesap
Jonathan	Spitzenburg	Grimes Golden
Rome Beauty	Yellow Newtown	W. W. Pearmain
Wagener	Arkansas Black	

New Varieties

In order of importance based on returns from nurserymen throughout the United States and Canada.

Delicious	Regan	Waldron Beauty
Black Ben Davis	Oliver	Vanderpool Red
Kauffman	Senator	Bietigheimer
Mrs. Bryan	Lowry	Ideal
Wallace Howard	Stark King David	Peter
Brilliant	Albany Everbearing	Chas. Ross
Reigel	Oreno	

Best Sellers

Best sellers as indicated by the largest number of nurserymen reporting a given variety.

Jonathan	14	Wagener	6	Delicious	3
Grimes	11	Yellow Transparent.....	5	Delicious	2
Winesap	10	Gano	5	M. B. Twig.....	2
Rome Beauty	8	Spitzenburg	4	Arkansas Black	2
Baldwin	7	Yellow Imperial	4	Black Ben Davis.....	2
McIntosh	7	Yellow Newtown	4	Bonum	1
Stayman	7	Northern Spy	3	Maiden Blush	1
Wealthy	6	Ben Davis	3	N. W. Greening.....	1

Table of Varieties Having the Highest Number of Recommendations

Apples having the highest number of recommendations for districts and states. This does not mean that these apples are necessarily best for every district; it simply means that they do well in the greatest number of places. The numeral following the name gives the number of recommendations according to the American Pomological Society.

Red Astrachan	65	Golden Sweet	29	Hall	21
Early Harvest	56	Smith's Cider	28	Limbertwig	21
Oldenberg	50	Benoni	28	Tompkins King	21
Maiden's Blush	50	Roxbury Russet.....	27	Hoas (Horse)	20
Winesap	49	Rambo	27	Nickajack	20
Ben Davis	47	Primate	26	Wagener	20
Gravenstein	43	Alexander	25	Willow Twig	20
Fameuse	36	Buckingham	25	Hewes Crab	19
Fall Pippin	35	Grimes	25	Jersey Sweet	19
Sweet Bough	35	L. Strawberry	25	Roman Stem	18
Baldwin	34	Peak's Pleasant	25	Fallwater	18
Jonathan	33	Summer Rose	25	Rome Beauty	18
Northern Spy	33	Early Strawberry	24	High Top Sweet.....	18
Porter	32	Mother	24	Wealthy	18
Ralls Janet.....	32	Shockley	24	Lowell	18
R. I. Greening	32	Twenty Ounce	22	Newtown Pippin	18
Tolman Sweet.....	32	Summer Queen	22	Keswick Codlin	17
Yellow Bellflower	31	Early Margaret	22	Spitzenburg	17
Sap of Wine	31	Dyer	22	Canada Red	15
None Such	30	Gilpin	21	York Imperial	13
William's Favorite	29	Golden Russet	21	White Winter Pearmain	12
Summer Pearmain	29				

Apples Recommended for Commercial Orchards in the United States and Canada

J. L. DUMAS

The tendency for the orchardists of the country to select fewer varieties for commercial plantings is well illustrated by the attempt on the part of the revision committee of the American Pomological Society to cut down the number of recommendations to fifty. The attempt did not succeed, but the suggestions to the committee, made by Mr. J. L. Dumas, of Pullman, Washington, chairman of the committee, are given.

Only 40 varieties are named, ten spaces being left blank to be supplied later.

Percentages of Sizes and Grades of Certain Varieties of Apples

The following table was made up of averages of 59,200 boxes of apples shipped during the season of 1911 by the Yakima Valley Fruit Growers' Association. The apples shipped were not of uniform pack but were taken from the farmer as he packed them.

	The different varieties showed the following percentage in each size Tier				The different varieties showed the following percentage in each grade		
	3	4	4½	5	Ex.Fancy	Fancy	Choice
Spitzenburg.....	9	59	26	6	35	30	35
Stayman.....	25	57	15	3	50	35	15
Jonathan.....	2	43	38	16	34	40	26
Arkansas Black.....	12	54	30	5	15	67	18
Grimes Golden.....	4	19	10	66	7	10	83
Rome Beauty.....	26	48	23	2	31	45	24
Gano.....	24	64	7	4	5	50	45
Delaware Red.....	61	58	35	37	39	24
Black Twig.....	18	49	40	6	40	40	20
York Imperial.....	12	48	28	1	33	39	28
Yellow Newtown.....	5	48	40	13	64	6	30
Ben Davis.....	17	54	23	5	26	16	58
Missouri Pippin.....	12	32	35	22	23	39	38
Wagener.....	5	79	40	3	83	14
Red Cheek Pippin....	12	55	30	3	16	20	64
Winesap.....	2	38	31	28	60	25	15
Various.....	5	27	58	10	15	30	55
*Total.....	12	45	30	13	37	37	26

* Winter Banana, White Winter Pearmain, Black Ben Davis omitted from list; very small shipments.

Bearing Ability of Certain Varieties at Certain Ages

Orchard of W. N. Yost, Meridian, Idaho, 2-year-old Jonathan trees planted in 1906:

Year.	Packed Boxes per Tree.
1910	1 2/3
1911	1 3/8
1912	4 4/5
1913 (heavy frost)	1 5/8
1914 (estimated)	6 to 7

I do very little pruning from the third

year on until the trees begin bearing freely. Prune and shape heavily second and third years, then scarcely any pruning until about the eighth year.

Two-year-old Rome Beauty trees planted in 1906:

Year.	Packed Boxes per Tree.
1910	5/8
1911	2 3/5
1912	3 3/10
1913 (heavy frost)	2 1/2
1914 (estimated)	6 to 7

**Apples Preferred by Hotels and Restaurants in the Northwest for Certain Purposes
Including Dining Car Department, Northern Pacific Railroad**

For Baking	For Pies	For Cooking	For Eating
Newtown Pippin	Yellow Newtown. . .	Yellow Newtown. . . .	Winesap
20 Oz. Pippin	R. I. Greening.	R. I. Greening.	Spitzenburg
Rome Beauty.	Duchess.	Duchess.	Jonathan
Red Cheek Pippin.	Gravenstein.	Red Cheek Pippin. . .	Winter Banana
.....	Winesap (3ds).	Winesap.	Delicious
.....	Yellow Newtown
.....	Bellflower
.....	Northern Spy
.....	Gravenstein

Size Most Used

3½ and 4 tier.	4 tier.	4 tier.	3½ and 4 tier
------------------------	-----------------	-----------------	---------------

Color Most Used

Red Cheek Pippin.	Red
---------------------------	-------	-------	-----

High class hotels desiring to cater to best trade.

**Ten Leading Varieties of Apples for Yakima Valley with Periods of Maturity and
Length of Keeping in Cold Storage**

H. M. GILBERT

Variety	Lower Valley Up to 1,000 feet elevation	Upper Valley Up to 1,800 feet elevation	Careful Cold Stor- age at proper time extends season
Jonathan.	Oct. 1 to Jan. 1	Oct 15 to Feb. 1	3 months
Grimes Golden.	Sept. 15 to Jan. 1	Oct. 1 to Jan. 15	2 months
Spitzenburg.	Oct. 15 to Jan. 15	Nov. 1 to Feb. 1	3 months
Delicious.	Oct. 15 to Jan. 15	Nov. 1 to Feb. 1	3 months
Stayman.	Nov. 1 to Feb. 1	Dec. 1 to Mar. 1	1½ months
Rome Beauty.	Nov. 15 to Feb. 15	Dec. 1 to Mar. 1	2 months
Yellow Newtown Pippin. . .	Dec. 15 to Feb. 1	Jan. 1 to Mar. 1	2 months
White Winter Pearmain. . .	Dec. 1 to Feb. 1	Jan. 1 to Mar. 15	2 months
Winesaps.	Dec. 1 to Mar. 1	Jan. 1 to April 1	4 months
Arkansas Black.	Dec. 1 to Mar. 1	Jan. 1 to April 1	3 months

If poorly treated and kept in a warm place after packing, all these apples will ripen a month earlier, and be out of condition at least two months earlier.

The above suggestions are general ones and I know every one will find some objections. I have seen Jonathans from the high lands kept well until April. Spitzenburgs can often be kept till May in good cold storage.

If the trees are vigorous and in good health, the apples seem to ripen later. I have also noticed the apples ripening a little later and keeping better where orchards are seeded to clover or alfalfa. Orchards allowed to get too dry will often ripen up exceptionally early, but I think the seasons given above will be found fairly accurate, and risk of loss will be encountered every time dealers or consumers try to keep apples later than the dates suggested.

COOKING QUALITY OF VARIOUS APPLES

At the National Apple Show in Spokane, Wash., in 1911, tests of various apples were made for cooking qualities by Miss Laura Breese of the Domestic Science Department of the University of Idaho. The tests were given each variety, for apple sauce, for baking and for pies. All tests were made without sugar.

The varieties were: Winter Banana, Grimes Golden, Rome Beauty, Winesap, Stayman Winesap, Arkansas Black, White Winter Pearmain, Babbitt, Jonathan, Delicious and York Imperial.

Baked Apples

In the baked apple contest, on color after being cooked, the Babbitt stood first, the Arkansas Black second. On general appearance after cooking the Arkansas Black stood first, the Rome Beauty second and Jonathan third. For taste in baked apples the Rome Beauty stood first and Jonathan and White Pearmain tied for second place.

Apple Sauce

In the apple sauce contest, on color the Arkansas Black stood first and Rome

Beauty second. On general appearance the Arkansas Black stood first, Rome Beauty second and Jonathan third.

For the best tasting apple sauce the Winter Banana stood first, White Winter Pearmain second and the Stayman Winesap third.

Apple Pie

Apple pie was judged for taste only. The Grimes Golden got first place, Babbitt second, and Jonathan third. A record of the time required to cook the different apples as sauce and by baking was made.

The number of minutes required to bake each apple follows: Delicious 38; Jonathan 54; Stayman Winesap 35; Winter Banana 51; York Imperial 64; Arkansas Black 63; Babbitt 44; Grimes Golden 49; White Winter Pearmain 49; Winesap 50; Rome Beauty 20.

The number of minutes required in the cooking of the apple sauce of each of the apples follows: Arkansas Black 7; White Winter Pearmain 9; Delicious 7; Jonathan 14; Stayman Winesap 8; Rome Beauty 8; York Imperial 25; Winesap 19; Winter Banana 10. The Babbitt was not entered in the sauce contest.

PRICES OF VARIETIES

The following prices represent an average constructed on the basis of a 3-year average of prices paid by Richey & Gilbert, Toppenish, Wash.; an average for seasons of 1911 and 1912 of the Hood River Apple Growers' Union and Davidson Fruit Co. of Hood River; the average price received by the Wenatchee Fruit Growers' Association and the Yakima Valley Fruit Growers' Association. Involving as it does widely separated districts, a variety of markets and several hundred thousand boxes of apples, we have a fair basis for comparison as to the value of the various varieties of apples named. The prices represent the average for all sizes and grades; where shipments of a given variety were too small to give a fair average no figures are given.

W. WORTHINGTON

Average Prices—Percentage of Grades—Percentage of Sizes

Average prices received for	Percentage of Grades			Percentage of Sizes*				
	Extra Fancy	"C"		3½ Tier	4 Tier	4½ Tier	5 Tier	
Winesap.....	\$1.39	60	25	15	2	32	33	33
Yellow Newtown.....	1.47	64	6	30	24	24	38	14
Arkansas Black.....	1.39	15	67	18	19	55	25	3
Spitzenburg.....	1.52	35	30	35	23	52	22	3
Jonathan.....	1.17	34	40	26	2	43	38	16
Rome Beauty.....	1.09	31	45	24	31	44	23	2
Black Twig.....	1.13	40	40	20	16	53	27	3
White Winter Pearmain.....	1.10	60	33	7	3	52	40	4
Ben Davis.....	.86	26	16	58	25	46	22	6
Missouri Pippin.....	.99	23	39	38	6	19	39	36
Baldwin.....								
Gano.....	.97	5	50	45	41	48	8	3
Delicious.....	Price	averages high, but			shipments small			
Grimes Golden.....	1.01	7	10	83	4	19	10	66
Delaware Red.....	.95	37	39	24	4	48	39	9
Canada Red.....					75	25		
Black Ben Davis.....								
Stayman.....	1.23	50	35	15	35	52	11	21
Wagener.....	.91	3	83	14	05	59	40	
Bellflower.....								
Gravenstein.....								
Red Cheek Pippin.....	1.17	16	20	64	22	52	23	3
Aikin.....								
York Imperial.....	1.18	33	39	28	10	48	36	4
Winter Banana.....	1.91	60	25	15	16	58	25	
King David.....								
Senator.....								
Ortley.....								

* Average of two shippers, 20,000 boxes each.

Nineteen Leading Varieties

The 19 leading varieties of apples as indicated by the displays for the past few years at the National Apple Show at Spokane, Washington, arranging the list alphabetically, is as follows:

Arkansas Black, Baldwin, Delicious, Gravenstein, Grimes Golden, Jonathan, McIntosh Red, Northern Spy, Rhode Island Greening, Rome Beauty, Spitzenburg, Stayman Winesap, Wagener, Wealthy, White Winter Pearmain, Winter Banana, Winesap, Yellow Bellflower, Yellow Newtown.

This list indicates the consensus of opinion as to the leading varieties at the time those trees now in bearing were planted and from which the apples were selected for exhibition.

GRANVILLE LOWTHER

VALUE OF SIZES AND GRADES OF APPLES

The following figures are given to indicate the difference in the value of the standard sizes and grades of apples of various varieties in the Northwest, and are based upon the average prices received by the Wenatchee and Yakima Valley Fruit Growers' Associations for the season of 1911-12:

DIFFERENCE IN VALUE OF GRADES

Grade	Size	Price	Average Difference All Sizes
Ex. Fancy.	3½x4 tier	\$1.46	1.33
Ex. Fancy.	4½x4 tier	1.37	
Ex. Fancy.	5 tier	1.17	
Fancy.....	3½x4 tier	1.30	1.19
Fancy.....	4½x4 tier	1.23	
Fancy.....	5 tier	1.03	
"C".....		.87	.87

Average difference in value of grades:

Ex. and Fancy.....	Av. \$0.14
Fancy and "C".....	.32
Ex. and "C".....	.46

Average difference of highest and lowest:
 Ex. Fancy 3½ and "C".....Av. \$0.59

Average difference in value between a 3½ tier and a 4½ tier apple is \$0.08.

Average difference in value between a 3½ tier and a 5 tier apple is \$0.25.

W. W.

RECOMMENDATIONS OF NURSERYMEN

As an indication of current opinion on the best varieties to plant in the various districts the following tables are given, having been compiled from reports of nurserymen throughout the United States. The varieties are given in the order of importance based on the largest number of nurserymen reporting the variety amongst the best sellers.

The numbers at the head of the columns are those of the American Pomological Society Districts for 1909. See accompanying map. (P. 192.)

District No. 8, Northern Illinois, Southern Iowa, Eastern Kansas and Nebraska, Northern Missouri.

Best Sellers

Jonathan	Baldwin	Salome
Grimes	Arkansas Black	Stark
Winesap	English Golden Russet	Tolman Sweet
Stayman Winesap	Fallowater	Walbridge
Ralls Janet	Gano	Winesap
Wealthy	Mann	Stayman
Maiden Blush	Minkler	Wolf River
Yellow Transparent	McIntosh	York Imperial
N. W. Greening	M. B. Twig	Whitney No. 20
Duchess of O.	Northern Spy	Ingram
Ben Davis	Princess Sweet	Early Harvest
Fameuse	Pewaukee	Rome Beauty
Stark Delicious	Black Ben Davis	White Winter Pearmain
Stark King David		

New Varieties

Delicious	Oliver	Stark King David
Regan	Senator	Stark Delicious
Black Ben Davis	Lowry	

District No. 12, Northern Arizona and New Mexico, Utah and Western Colorado.

Best Sellers

Rome Beauty	Jonathan	Gano
Winesap	Stayman	

New Varieties

Black Ben Davis	Delicious
-----------------	-----------

District No. 14, Eastern California, Washington, and Oregon. Western Montana, Idaho.

Best Sellers

Spitzenburg	Rome Beauty	Delicious
Yellow Newtown	Wagener	Wealthy
Winesap	Grimes	McIntosh Red
Jonathan		

New Varieties

Albany Everbearing	Vanderpool Red	Peter
Oreno	Bietigheimer	Delicious
Waldron Beauty	Ideal	Stayman Winesap

District No. 15, Western Washington, Oregon and Northwestern California.

Best Sellers

Jonathan	Cox Orange Pippin	Grimes
Wagener	Wealthy	Spitzenburg
McIntosh	King	Yellow Newtown
Yellow Bellflower	Baldwin	Ben Davis
Northern Spy	Winesap	

New Varieties

Chas. Ross

District No. 2, Michigan, Northern Indiana, Ohio, and Pennsylvania, Southern New York, Vermont, Massachusetts, Southern Maine, Northern Connecticut.

Best Sellers

Baldwin	Grimes	Jonathan
McIntosh	Stayman Winesap	Winesap
Spy		

District No. 3, Delaware, Rhode Island, Eastern Virginia, and all of New Jersey.

Best Sellers

Baldwin	Ben Davis	Grimes
Jonathan	M. B. Twig	McIntosh
Nero	Rome Beauty	Spitzenburg
Stayman Winesap	Stark Wealthy	Winesap
Williams E. Red	Yellow Transparent	York Imperial

District No. 5, Southern Georgia and South Carolina, and Eastern South Carolina.

Best Sellers

Arkansas Black	Magnum Bonum	Stayman Winesap
Harvest	Yellow Transparent	Horse
Kansas Queen	Red June	Fall Pippin
Grimes	Gano	Rome Beauty
Shockley	Winter Queen	Yates
York Imperial	Winesap	

New Varieties

Kauffman	Mrs. Bryan	Wallace
Howard	Brilliant	Reigel

**WEIGHTS OF VARIETIES OF APPLES
PER BUSHEL**

The following varieties, just from the trees in October, gave the following weights for a heaped bushel (Michigan):

	Pounds.
Baldwin	50
Belmont	50
Ben Davis	47
Bunker Hill	49
Cabashae	57
Esopus Spitzenburg	44
Rambo	50
Rhode Island Greening.....	52

Roxbury Russet	50
Rubicon	46
Stark	56
Fallwater	48
Golden Russet	53
Lawyer	47
Nickajack	51
Northern Spy	46
Pennock	47
Swaar	51
Sweet Bough	39
Tolman Sweet	48
Tompkins King	44
Yellow Bellflower	46

Bailey's Rule Book, p. 149.

Recommendations of the American Pomological Society

Following are the recommendations of the American Pomological Society as given in Bulletin 151, Bureau of Plant Industry.

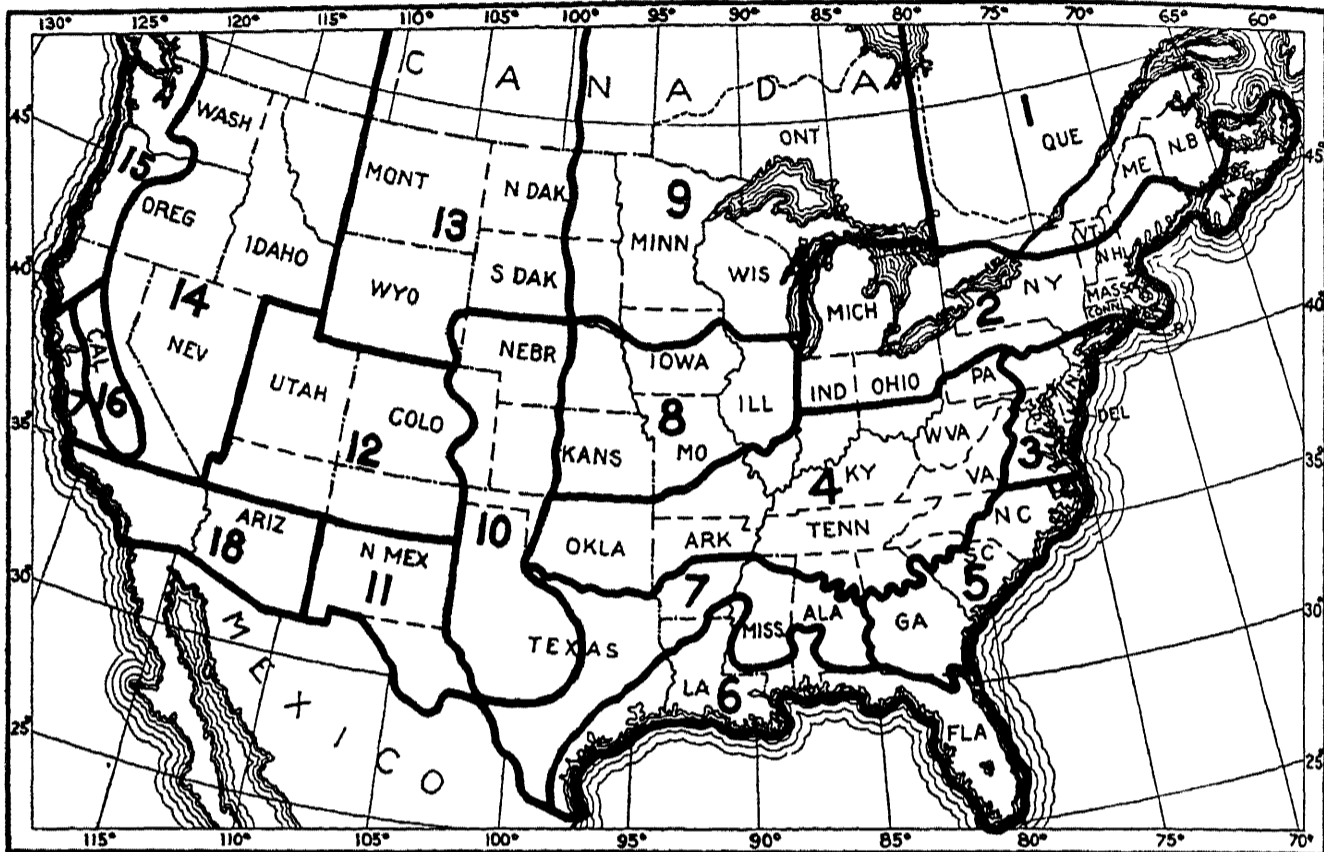

MAP SHOWING THE POMOLOGICAL DISTRICTS OF THE UNITED STATES AND CANADA.

DISTRICT NO. 1

Maine above 500 feet above sea level; New Hampshire, Vermont, and New York north of latitude 44 degrees; Ontario north of Lake Simcoe and east of longitude 80 degrees; Quebec, New Brunswick, and Prince Edward Island. The dominant natural feature of this district is the St. Lawrence valley. Many of the hardier fruits flourish within its borders.

Apples

HIGHLY RECOMMENDED—*Dessert, kitchen and market*: Gravenstein; Northern Spy; Wealthy. *Kitchen and market*: Haas (*Fall Queen, Gros Pomier*); Hibernial; Oldenburg. *Duchess of*; Pewaukee; Scott Winter; Tolman Sweet; Twenty Ounce (*Cayuga Redstreak*); Wolf River; Yellow Transparent. *Dessert and market*: Bailey Sweet; Blue Pearmain; Fameuse (*Snow*); McIntosh; McMahan; Peach of Montreal; Porter; Saint Lawrence. *Market*: Tetofski. *Kitchen*: Gideon; Longfield; Quince, Cole; Switzer.

RECOMMENDED—*Dessert, kitchen and market*: Bogdanoff; Canada Baldwin; Donneghan; Magog Red Streak; Malinda; Northfield; Rhode Island Greening; Russian Baldwin; Saint Johnsbury; Shiawassee Beauty; Starkey; Yellow Bellflower. *Kitchen and market*: Alexander; Antonovka; Baldwin; Blenheim; Borovinka; Irish Peach; Mann; Raspberry; Red Astrachan; Roxbury Russet; Titovka. *Dessert and market*: Canada Reinette; Derby; Early Strawberry; Golden Russet (N. Y.); Hubbardston Nonsuch; Plumb Cider; Red Canada; Tompkins King; Wagener; Westfield Seek-no-further; Williams Favorite. *Dessert and kitchen*: Early Harvest; Fall Harvey; Fall Pippin; Lady Sweet; Ribston Pippin; White Pigeon; Wythe. *Market*: Ben Davis; Bethel; Cooper Market; Domine; English Russet; Fallwater (*Tulpehocken*); Fall Jenneting; Gano; Ontario; Stark; Walbridge (*Edgar Redstreak*). *Dessert*: Bough, Sweet; Cornell Fancy; Grimes Golden; Hunt Russet; Jewett Red (*Nodhead*):

Late Strawberry; Pomme Gris; Sops of Wine, Winter St. Lawrence. *Kitchen*: Green Sweet; Kent Beauty; Keswick Codling; Pumpkin Sweet (*Pound Sweet*).

RECOMMENDED FOR TRIAL—*Dessert, kitchen and market*: Rolfe (*Macomber*). *Kitchen and market*: Arctic; Northwestern Greening. *Dessert and market* Sutton Beauty; Swayzie Pomme Gris. *Market*: Bietigheimer, Red. *Dessert*: Louise, Princess. *Kitchen*: Munscn.

Apples, Crab

HIGHLY RECOMMENDED — *Kitchen and market*: Martha; Minnesota. *Kitchen*: Gibb; Red Siberian.

RECOMMENDED—*Dessert, kitchen and market*: Jumbo; Pringle Sweet; Whitney. *Cider, kitchen and market* Montreal. *Kitchen and market*: Elgin; Hyslop; Marengo; Queen Choice; Transcendent; Yellow Siberian. *Dessert and kitchen*: Island Gem. *Dessert*. Van Wyck. *Kitchen*: Ball Winter; Orange; Stanstead, Rose of.

DISTRICT NO. 2

Nova Scotia; Maine below 500 feet elevation; New Hampshire and Vermont south of latitude 44 degrees; Massachusetts; Rhode Island; Connecticut; New York south of latitude 44 degrees, except Long Island; Northern New Jersey above 500 feet elevation; Pennsylvania east of the Susquehanna river and above 500 feet elevation, north of latitude 41 degrees west to the Allegheny river, and that portion of the state lying north of the Ohio river; Ohio and Indiana north of latitude 40 degrees; and the lower peninsula of Michigan. The Annapolis valley of Nova Scotia, the North Atlantic coast, the lake region of Western New York, Ohio and Michigan, and the Hudson river valley are the leading features of District No. 2. This may be considered the northern grape, peach and winter apple district.

Apples

HIGHLY RECOMMENDED—*Dessert, kitchen and market*: Gravenstein; Jonathan; Northern Spy; Peck Pleasant; Rhode Island Greening; Shiawassee Beauty; Wealthy. *Kitchen and market*: Baldwin; Maiden Blush; Mann; Oldenburg, Duchess of; Red Astrachan; Roxbury Russet; Tol-

man Sweet, Twenty Ounce (*Cayuga Red-streak*); Yellow Transparent. *Dessert and market*: Bailey Sweet; Chenango Strawberry; Early Strawberry; Fameuse (*Snow*); Golden Russet (N. Y.); Hubbardston Nonsuch; McIntosh; Peach of Montreal; Porter; Red Canada; Sutton Beauty; Tompkins King; Wagener; Washington Strawberry; Westfield Seek-no-further. *Dessert and kitchen*: Early Harvest; Fall Harvey; Golden Sweet. *Market*: Ben Davis; Domine; Fanny; Stark; Tetofski. *Dessert*: Benoni; Bough, Sweet; Bullock (*American Golden Russet*); Dyer (*Pomme Royal*); Early Joe; Esopus Spitzenburg; Grimes Golden; Hightop Sweet; Hunt Russet; Jefferis; Jewett Red (*Nod-head*); Summer Pearmain. *Kitchen*: Gideon; Green Sweet; Munson.

RECOMMENDED — *Dessert, kitchen and market*: Foundling; Green Newtown; Rolfe (*Macomber*); Rome Beauty; Wine-sap; Yellow Bellflower; Yellow Newtown (*Albemarle*). *Kitchen and market*: Alexander; Arkansas (*Mammoth Black Twig*); Belle Bonne; Blenheim; Borovinka; Buckingham (*Fall Queen*); Clayton; Danvers Sweet; Early Pennock; Haas (*Fall Queen, Gros Pomier*); Irish Peach; Kirkbridge White; Lowell; Northwestern Greening; Ohio Pippin (*Shannon*); Pewaukee; Ramsdell Sweet; Red-stripe; Scott Winter; Smith Cider; Summer Queen; Titovka; Vandevere; Wolf River. *Dessert and market*: Arnold; Blue Pearmain; Buncombe (*Red Winter Pearmain*); Canada Reinette; Champlain (*Nyack Pippin*); Cogswell; Jacobs Sweet; Lady (*Lady Apple*); Lawver; McMahon; Melon, Norton; Minister; Ohio Nonpareil; Ortle; Plumb Cider; Red June, Carolina; Saint Lawrence; Swayzie Pomme Gris; White Pearmain (*W. W. Pearmain*); White Pippin; Williams Favorite; York Imperial (*Johnson's Fine Winter*). *Dessert and kitchen*: Broadwall Sweet; Fall Pippin; Golding (*American Golden Pippin*); Jersey Sweet; Kinnard; Lady Sweet; Pease, Walter; Perry Russet; Rambo; Ribston Pippin; Roman Stem; Sweet Winesap. *Kitchen and cider*: Gilpin (*Little Red Romanite*). *Market*: Bethel; Bietigheimer, Red; Clyde Beauty; Cooper; Cooper Market; English Russet;

Fallowater (*Tulpehocken*); Fall Jenneting; Gano; Lansingburg; Limbertwig; Nickajack; Ontario; Ralls Genet (*Janet, Neverfail*); Walbridge (*Edgar Redstreak*); Willow Twig. *Dessert*: Autumn Bough; Autumn Swaar; Belmont; Black, Jersey; Cornell Fancy; Evening Party; Fall Wine; Garden Royal; Late Strawberry; Louise, Princess; McLellan; Mother; Newtown Spitzenburg; Pomme Gris; Primate; Russell; Sops of Wine; Sterling (*American Beauty*); Summer Rose; Swaar. *Kitchen*: Bentley; Ewalt; Fall Orange; Keswick Codling; Longfield; Moore Sweet; Pumpkin Sweet (*Pound Sweet*); Quince, Cole; Smokehouse; Switzer. *Cider*: Hewes.

RECOMMENDED FOR TRIAL—*Dessert, kitchen and market*: Brown (*Nottingham Brown*); Donnegan; Lehigh Greening; Saint Johnsbury. *Kitchen and market*: Antonovka; Arctic; Whinery. *Dessert and kitchen*: Krauser.

Apples, Crab

HIGHLY RECOMMENDED—*Dessert, kitchen and market*: Whitney. *Cider, kitchen and market*: Montreal. *Kitchen and market*: Hyslop; Marengo; Martha; Transcendent. *Dessert*: Van Wyck.

RECOMMENDED—*Dessert, kitchen and market*: Jumbo. *Kitchen and market*: Beach; Elgin; Minnesota; Queen Choice; Yellow Siberian. *Dessert and kitchen*: Island Gem. *Kitchen*: Excelsior; Orange; Red Siberian.

DISTRICT NO. 3

Long Island; New Jersey, except a small portion north; Eastern Pennsylvania, below 500 feet elevation; Delaware; the District of Columbia; and those portions of Maryland and Virginia below 500 feet elevation. This is the Delaware and Chesapeake bay district. Though a small district, its productive capacity of the fruits that succeed within its borders is great.

Apples

HIGHLY RECOMMENDED—*Dessert, kitchen and market*: Gravenstein; Rome Beauty; Stayman Winesap; Wealthy; Winesap; Yellow Newtown (*Albemarle*). *Kitchen and*

market: Arkansas (*Mammoth Black Twig*); Nansemond Beauty; Nero; Red Astrachan; Smith Cider; Yellow Transparent. *Dessert and market*: Early Ripe; Early Strawberry; Hubbardston Nonsuch; Ohio Nonpareil; Porter; Wine, Hays; York Imperial (*Johnson's Fine Winter*). *Dessert and Kitchen*: Fall Pippin; Kinnard; Rambo; Roman Stem. *Market*: English Russet; Fallowater (*Tulpehocken*); Fanny; July, Fourth of; Stark; Willow Twig. *Dessert*: Benoni; Fall Wine; Grimes Golden; Margaret, Early Red; Mason Stranger. *Kitchen*: Fall Orange; Keswick Codling; Smokehouse.

RECOMMENDED—*Dessert, kitchen and market*: Jonathan; Noyes, Doctor; Peck Pleasant; Starkey; Yellow Bellflower. *Kitchen and market*: Alexander; Baldwin; Early Pennock; Green Cheese; Haas (*Fall Queen, Gros Pomier*); Lowell; Maiden Blush; Mann; Maryland Maid (*Maryland Maiden Blush*); Oldenburg, Duchess of; Ramsdell Sweet; Roxbury Russet; Summer Hagloe; Summer Queen; Twenty Ounce (*Cayuga Redstreak*). *Dessert and market*: Bradford (*Kentucky Redstreak*); Buncombe (*Red Winter Pearmain*); Champlain (*Nyack Pippin*); Chenango Strawberry; Lankford; Lawver; Lilly of Kent; Paragon; Plumb Cider; Red June, Carolina; Saint Lawrence; Shockley; Stephenson; Tompkins King; Townsend; Vanhoy; Washington Strawberry; Williams Favorite. *Dessert and kitchen*: Early Harvest; Golden Sweet; Lady Sweet; Oconee; Perry Russet; Ribston Pippin; Summer King; Yellow June. *Kitchen and cider*: Gilpin (*Little Red Romanite*). *Market and cider*: Horse. *Market*: Ben Davis; Bietigheimer, Red; Cooper Market; Domine; Gano; Lansingburg; Limbertwig; McAfee; Missouri Pippin; Ralls Genet (*Janet, Neverfail*); Ridge Pippin. *Dessert*: Bonum; Bough, Sweet; Colton, Early; Early Joe; Jefferis; Julian; McLellan; Primate; Sops of Wine; Summer Pearmain; Summer Rose. *Kitchen*: Garrettson; Mattemuskeet.

RECOMMENDED FOR TRIAL—*Dessert, kitchen and market*: Brown (*Nottingham Brown*); Rolfe (*Macomber*). *Dessert and market*: McIntosh; Sutton Beauty. *Dessert and kitchen*: Pease, Walter.

Apples, Crab

HIGHLY RECOMMENDED—*Cider, kitchen and market*: Montreal. *Kitchen and market*: Hyslop; Yellow Siberian.

RECOMMENDED—*Dessert, kitchen and market*: Whitney. *Kitchen and market*: Transcendent. *Kitchen*: Gibb; Orange; Red Siberian.

DISTRICT NO. 4

Pennsylvania above 500 feet elevation and south of latitude 41 degrees; Maryland, Virginia, North Carolina, South Carolina, Georgia, Mississippi, and Alabama, above 500 feet elevation; West Virginia, Kentucky; Tennessee; Ohio and Indiana south of latitude 40 degrees; Southern Illinois, below the general elevation of 500 feet, from the Wabash to the Mississippi; Missouri south of a line from near St. Louis and along the elevation of 1,000 feet to the southeast corner of Kansas; Oklahoma below 2,000 feet elevation; Indian Territory; and Arkansas north of latitude 35 degrees and also south of it wherever the elevation exceeds 500 feet. The Allegheny and the Ozark mountains, the valleys of the Ohio, the Tennessee, and the Cumberland, and portions of the Wabash, the Mississippi, and the Arkansas rivers are embraced within this district. Portions of it are noted fruit regions, while throughout its vast territory the hardier deciduous fruits flourish. Many of the varieties recommended succeed best in certain localities within the district. An exception to the general character of the district occurs in those portions of Kentucky, Tennessee, Arkansas, and Southeastern Missouri lying near the Mississippi river, where the varieties adapted to culture in Districts Nos. 5 and 7 generally succeed.

Apples

HIGHLY RECOMMENDED—*Dessert, kitchen and market*: Gravenstein; Jonathan; Rome Beauty; Wealthy; Winesap; Yellow Newtown (*Albemarle*). *Kitchen and market*: Arkansas (*Mammoth Black Twig*); Buckingham (*Fall Queen*); Maiden Blush; Oldenburg, Duchess of; Red Astrachan; Red Stripe; Yellow Transparent. *Dessert and market*: Bailey Sweet; Buncombe (*Red Winter Pearmain*); Paragon;

Red June; Shockley; Stephenson; White Pippin; Wine, Hays; York Imperial (*Johnson's Fine Winter*). *Dessert and kitchen*: Early Harvest; Fall Pippin; Summer King. *Cider and market*: Horse. *Market*: Ben Davis; Cullasaga; Fanny; Gano; Ralls Genet (*Janet, Neverfail*); Stark; Willow Twig. *Dessert*: Benoni; Bonum; Bough, Sweet; Carter Blue; Grimes Golden; Jefferis; Margaret, Early Red; Romanite, South; Watson, Carolina.

RECOMMENDED—*Dessert, kitchen and market*: Green Newtown; Northern Spy; Peck Pleasant; Rhode Island Greening; Salome; Shiawassee Beauty; Starkey; Stayman Winesap; Yellow Bellflower. *Dessert, kitchen and cider*: Hunge. *Kitchen and market*: Alexander; Baldwin; Carolina Beauty; Clayton; Danvers Sweet; Early Pennock; Gilbert; Green Cheese; Heslep; Hoover; Kirkbridge White; Lowe; Lowell; Mann; Ohio Pippin (*Shannon*); Pewaukee; Ramsdell Sweet; Roxbury Russet; Smith Cider; Summer Hagloe; Summer Queen; Tetofski; Tolman Sweet; Trenton Early; Twenty Ounce (*Cayuga Redstreak*); Vandevere; Wolf River. *Dessert and market*: Blue Pearmain; Bradford (*Kentucky Redstreak*); Cannon Pearmain; Chenango Strawberry; Early Ripe; Early Strawberry; Fameuse (*Snow*); Farrar (*Robinson Superb*); Fulton; Golden Russet (N. Y.); Hubbardston Nonsuch; Huntsman Favorite; Lady Apple; Lankford; Lawver; McIntosh; Melon Norton; Minister; Monmouth (*Red Cheek Pippin*); Ohio Nonpareil; Ortley; Porter; Red Canada; Terry Winter; Tompkins King; Townsend; Vanhoy; Wagener; Washington Strawberry; Westfield Seek-no-further; White Pearmain (*W. W. Pearmain*); Williams Favorite. *Dessert and kitchen*: Broadwell; Camak; Golden Sweet; Golding (*American Golden Pippin*); Kinnard; Oconee; Pryor Red; Rambo; Ribston Pippin; Roman Stem; Yellow June. *Kitchen and cider*: Gilpin (*Little Red Romanite*). *Market*: Beach (*Richardson's Red, Apple of Commerce*); Bietigheimer, Red; Colins (*Champion*); Domine; Early Cooper; English Russet; Fallwater (*Tulpehocken*); Fall Jenneting; Fink; Hockett; Horn; July, Fourth of; Lansingburg;

Limbortwig; McAfee; Minkler; Missouri Pippin; Oliver (*Senator*); Virginia Greening; Walbridge (*Edgar Redstreak*); Yates. *Dessert*: Autumn Bough; Autumn Swaar; Belmont (*Waxen*); Bullock (*American Golden Russet*); Colton, Early; Cornell Fancy; Early Joe; Esopus Spitzenburg; Evening Party; Fall Wine; Family; Hall; Hightop Sweet; Julian; Junaluskee; Late Strawberry; Mangum (*Gulley*); Mother; Primate; Sops of Wine; Summer Pearmain; Summer Rose; White Juneating (*Yellow May*). *Kitchen*: Bentley; Cracking; Ewalt; Gideon; Kent Beauty; Keswick Codling; Moore Sweet; Munson; Pumpkin Sweet (*Pound Sweet*); Smokehouse; Taunton. *Cider*: Hewes.

RECOMMENDED FOR TRIAL—*Dessert, kitchen and market*: Brown, Nottingham; Lehigh Greening; Noyes, Doctor. *Kitchen and market*: Maryland Maid (*Maryland Maiden Blush*); Monsees (*Hopewell*); Northwestern Greening; Whinery. *Dessert and market*: Ingram; Kernodle; McCuller; Sutton Beauty. *Dessert and kitchen*: Krauser; Nansemond; Wetmore. *Market*: Carlough. *Dessert*: Millboy. *Kitchen*: Longfield; Switzer.

Apples, Crab

HIGHLY RECOMMENDED — *Kitchen and market*: Hyslop; Transcendent.

RECOMMENDED — *Dessert, kitchen and market*: Whitney. *Kitchen and market*: Elgin; Yellow Siberian. *Dessert*: Van Wyck. *Kitchen*: Red Siberian.

DISTRICT NO. 5

Eastern North Carolina, South Carolina, and Georgia, below 500 feet elevation, and Florida, north of latitude 30 degrees, east of the Chattahoochee river, and above 100 feet elevation. This district embraces the Southern Atlantic seaboard, with its many frithlike indentations and valleys. The climate is generally mild, and within its borders many of the more tender deciduous fruits flourish.

Apples

HIGHLY RECOMMENDED—*Dessert and market*: Schockley; Terry Winter. *Kitchen and market*: Buckingham (*Fall Queen*). *Market*: Yates. *Dessert*: Bonum; Sum-

mer Rose; White Juneating (*Yellow May*).

RECOMMENDED — *Dessert, kitchen and market*: Jonathan; Rhode Island Greening; Rome Beauty; Stayman Winesap; Winesap; Yellow Newtown (*Albemarle*). *Dessert, kitchen and cider*: Hunge. *Kitchen and market*: Carolina Beauty; Green Cheese; Lowe Maiden Blush; Maryland Maid (*Maryland Maiden Blush*); Maverack; Nansemond; Red Astrachan; Smith Cider; Summer Queen; Tolman Sweet; Yellow Transparent. *Dessert and market*: Buncombe (*Red Winter Pearmain*); Chenango Strawberry; Clark Pearmain; Early Ripe; Early Strawberry; Kernodle; Lady Apple; Lankford; McCuller; Paragon; Red June, Carolina; Stephenson; Vanhoy; White Pearmain (*W. W. Pearmain*); Wine, Hays; York Imperial (*Johnson's Fine Winter*). *Dessert and kitchen*: Early Harvest; Kinnard; Oconee; Pryor Red; Yopp. *Cider and market*: Horse. *Market*: Ben Davis; English Russet; Gano; Hockett; Horn; Limbertwig; McAfee; Nickajack. *Dessert*: Bough, Sweet; Carter Blue; Colton, Early; Early Joe; Fall Wine; Family; Grimes Golden; Hall; Julian; Junaluskee; Late Strawberry; Mangum (*Gulley*); Margaret, Early Red; Mason Stranger; Mother; Romanite, South; Summer Pearmain; Watson, Carolina. *Kitchen*: Fall Orange; Garrettson; Mattamuskeet; Smokehouse; Taunton. *Cider*: Hewes.

RECOMMENDED FOR TRIAL—*Kitchen and market*: Arkansas (*Mammoth Black Twig*); Heslep.

Apples, Crab

RECOMMENDED — *Kitchen and market*: Transcendent. *Kitchen*: Red Siberian.

DISTRICT NO. 6

Florida south of latitude 30 degrees, and the remaining portions of the state with elevations below 100 feet, and those portions of Alabama, Mississippi, Louisiana, Arkansas, and Texas lying below the 100-foot contour line as it skirts the coast from Florida to the Rio Grande. This is the Southern Peninsula and Gulf Coast district. The successful culture of citrus and other subtropical fruits and nuts is restricted to the peninsula portion of

Florida and to the Delta of the Mississippi. Tropical species are only recommended for that portion of Florida lying south of latitude 27 degrees

Apples

HIGHLY RECOMMENDED—*Dessert and market*: Red June, Carolina.

RECOMMENDED — *Kitchen and market*: Oldenburg, Duchess of. *Dessert and market*: Shockley. *Dessert and kitchen*: Yopp. *Dessert*: Watson, Carolina. *Kitchen*: Taunton.

RECOMMENDED FOR TRIAL—*Kitchen and market*: Red Astrachan. *Market*: Nickajack.

Apples, Crab

RECOMMENDED — *Dessert, kitchen and market*: Whitney. *Kitchen and market*: Hyslop; Transcendent.

DISTRICT NO. 7

Florida west of the Chattahoochee river and above 100 feet elevation; Alabama, Mississippi, Louisiana, and Arkansas, above 100 and below 500 feet elevation; and Texas south of the Red river and with an elevation from 100 to 1,000 feet. This may be denominated the Valley district. It embraces portions of the Chattahoochee, Alabama, Pearl, Mississippi, Arkansas, Red, Sabine, Colorado (of Texas), and Rio Grande valleys. The climate in the eastern and larger portion is warm and moist; in the extreme west more dry and tending toward aridity. A wide range of the more tender varieties and species is adapted to culture in this district.

Apples

HIGHLY RECOMMENDED — *Kitchen and market*: Arkansas (*Mammoth Black Twig*); Buckingham (*Fall Queen*); Oldenburg, Duchess of; Red Astrachan; Summer Queen. *Dessert and market*: Red June, Carolina; Shockley. *Dessert and kitchen*: Kinnard; Yellow June; Yopp. *Cider and market*: Horse. *Market*: Gano; Yates. *Dessert*: Summer Pearmain; Watson, Carolina. *Kitchen*: Taunton.

RECOMMENDED — *Dessert, kitchen and market*: Bryan, Mrs.; Jonathan; Rome Beauty; Winesap; Yellow Bellflower. *Kitchen and market*: Bledsoe; Early

Pennock; Green Cheese; Maiden Blush; Maverack; Ohio Pippin (*Shannon*); Trenton Early; Wetsel; Yellow Transparent. *Dessert and market*: Bradford (*Kentucky Redstreak*); Buncombe (*Red Winter Pearmain*); Champlain (*Nyack Pippin*); Clark Pearmain; Early Strawberry; Farrar (*Robinson Superb*); Lawver; Townsend; York Imperial (*Johnson's Fine Winter*). *Dessert and kitchen*: Broadwell; Early Harvest. *Market*: Ben Davis; Cullasaga; Domine; Doyle; Early Cooper; English Russet; Fanny. *Dessert*: Benoni; Bonum; Bough, Sweet; Carter Blue; Cornell Fancy; Early Joe; Esopus Spitzenburg; Hall; Jefferis; Jewett Red (*Nodhead*); Margaret, Early Red. *Kitchen*: Cracking; Garrettson; Smokehouse.

RECOMMENDED FOR TRIAL—*Dessert, kitchen and market*: Wealthy.

Apples, Crab

RECOMMENDED — *Dessert, kitchen and market*: Whitney. *Kitchen and market*: Hyslop; Transcendent.

DISTRICT NO. 8

Illinois north of the 500-foot contour line as it crosses the state between 38 degrees and 39 degrees latitude; a small portion of Southwest Wisconsin; Iowa south of latitude 42 degrees 30 minutes; the Missouri river valley portion of Southeastern South Dakota; Nebraska and Kansas below 2,000 feet elevation, and Missouri north of a line drawn from near St. Louis and along the elevation of 1,000 feet to the southeast corner of Kansas. The Missouri and Mississippi valley sections of the district are its dominant features. The hardy deciduous fruits succeed in most portions, and commercial fruit growing has recently become a very important industry.

Apples

HIGHLY RECOMMENDED—*Dessert, kitchen and market*: Jonathan; Rome Beauty; Wealthy; Winesap. *Kitchen and market*: Hoover; Lowell; Maiden Blush; Oldenburg, Duchess of; Ramsdell Sweet; Red Stripe; Summer Queen; Trenton Early; Yellow Transparent. *Dessert and market*: Bradford (*Kentucky Redstreak*); Cannon Pearmain; Chenango Strawberry;

Fameuse (*Snow*); Fulton; Hubbardston Nonsuch; Huntsman Favorite; Porter; Red June, Carolina; White Pippin; Wine, Hays; York Imperial (*Johnson's Fine Winter*). *Dessert and kitchen*: Broadwell; Early Harvest; Golden Sweet; Roman Stem; Wythe. *Market and cider*: Horse. *Market*: Ben Davis; Cooper; Domine; Gano; Minkler; Missouri Pippin; Ralls Genet (*Janet, Neverfail*); Willow Twig. *Dessert*: Benoni; Bough, Sweet; Dyer (*Pomme Royal*); Fall Wine; Grimes Golden; Jefferis; Margaret, Early Red; Summer Pearmain. *Kitchen*: Fall Orange.

RECOMMENDED—*Dessert, kitchen and market*: Babbitt (*Western Baldwin*); Gravenstein; Green Newtown; Northern Spy; Peck Pleasant; Salome; Shiawasse Beauty; Stayman Winesap. *Kitchen and market*: Antonovka; Arkansas (*Mammoth Black Twig*); Blenheim; Buckingham (*Fall Queen*); Clayton; Danvers Sweet; Early Pennock; Haas (*Fall Queen, Gros Pomier*); Isham Sweet; Kirkbridge White; Mann; Milwaukee; Monsees (*Hopewell*); Nansemond Beauty; Northwestern Greening; Ohio Pippin (*Shannon*); Pewaukee; Red Astrachan; Smith Cider; Tolman Sweet; Wolf River. *Dessert and market*: Bailey Sweet; Blue Pearmain; Buncombe (*Red Winter Pearmain*); Canada Reinette; Champlain (*Nyack Pippin*); Charlamoff; Early Ripe; Early Strawberry; Golden Russet (N. Y.); Ingram; McIntosh; McMahan; Minister; Monmouth (*Red Cheek Pippin*); Ortle; Paragon; Red Canada; Saint Lawrence; Townsend; Wagener; Westfield Seek-no-further; White Pearmain (*W. W. Pearmain*); Williams Favorite. *Dessert and kitchen*: Dutch Mignonne; Fall Pippin; Golding (*American Golden Pippin*); Perry Russet; Pryor Red; Rambo; Yellow June. *Kitchen and cider*: Gilpin (*Little Red Romanite*). *Market*: Bietigheimer, Red; Clyde Beauty; Cooper Market; Early Cooper; English Russet; Fallwater (*Tulpehocken*); Fanny; Fink; Lansingburg; Limbertwig; Nickajack; Stark; Tetofski; Walbridge (*Edgar Redstreak*). *Dessert*: Autumn Bough; Autumn Swaar; Black Jersey; Cornell Fancy; Early Joe; Evening Party; Family; Garden Royal; Hall; Hightop Sweet; Jewett Red (*Nod-*

head); Late Strawberry; McLellan; Mother; Newtown Spitzenburg; Sops of Wine; Sterling (*American Beauty*); Summer Rose. *Kitchen*: Cracking; Kent Beauty, Keswick Codling; Longfield; Moore Sweet; Pumpkin Sweet (*Pound Sweet*); Quince, Cole; Switzer.

RECOMMENDED FOR TRIAL—*Dessert, kitchen and market*: Garfield. *Kitchen and market*: Borovinka; Green Glass; Judson; Kaump; Nero; Okabena; Scott Winter. *Dessert and market*: Anisim; Peach of Montreal; Shockley; Sutton. *Dessert and kitchen*: Kinnard. *Market*: Oliver (*Senator*). *Kitchen*: Gideon.

Apples, Crab

HIGHLY RECOMMENDED—*Dessert, kitchen and market*: Whitney. *Kitchen and market*: Hyslop; Martha.

RECOMMENDED—*Kitchen and market*: Brier; Marengo; Transcendent; Yellow Siberian. *Kitchen*: Excelsior; Red Siberian.

DISTRICT NO. 9

Wisconsin, except the southwest corner; Minnesota; Upper Michigan; Iowa north of latitude 42 degrees, 30 minutes; North Dakota and South Dakota east of longitude 99 degrees; and the British provinces west of longitude 80 degrees and east of longitude 99 degrees. This district embraces the upper lakes, including Winnipeg, and also the Upper Mississippi and the Red river valleys. Only the hardier fruits succeed, but fair progress has been made in recent years in developing varieties adapted to this region.

Apples

HIGHLY RECOMMENDED—*Kitchen and market*: Wolf River. *Market*: Windsor.

RECOMMENDED—*Dessert, kitchen and market*: Malinda; Ogle (*Winter Snow*). *Kitchen and market*: Antonovka; Haas (*Fall Queen, Gros Pomier*); Hibernial; Kaump; Livland Raspberry (*Lowland Raspberry*); Maiden Blush; Milwaukee; Newell; Northwestern Greening; Okabena; Patten Greening; Peter; Trenton Early; Yellow Transparent. *Dessert and market*: Anisim; Charlamoff; Golden Russet (N. Y.); McMahan; Peach of Montreal; Plumb Cider; Saint Lawrence; Utter. *Dessert and kitchen*: Perry Russet; Sweet

Winesap *Market*: English Russet, Peerless; Tetofski; Walbridge (*Edgar Redstreak*). *Kitchen*: Longfield; Switzer.

RECOMMENDED FOR TRIAL—*Dessert, kitchen and market*: Garfield. *Kitchen and market*: Borovinka; Cross; Green Glass; Judson; Perfection; Raspberry; Scott Winter. *Dessert and market*: McIntosh. *Dessert and kitchen*: Christmas; White Pigeon. *Market*: Gano. *Dessert*: Grimes Golden. *Kitchen*: Gideon.

Apples, Crab

HIGHLY RECOMMENDED—*Kitchen and market*: Beach; Hyslop.

RECOMMENDED—*Kitchen and market*: Brier.

DISTRICT NO. 10

Nebraska, Kansas and Oklahoma above 2,000 elevation; Texas above 2,000 feet elevation and north of the Red river and latitude 35 degrees; also Eastern Colorado below 5,000 feet. This is the Central Plain and Foothill district. It lies on the eastern slope of the Continental Divide. There are small sections, especially in Eastern Colorado, where the apple and other hardy fruits are very successfully grown.

Northwestern Texas above 1,000 feet in elevation, south of the Red river and latitude 35 degrees and east of longitude 103 degrees and the Pecos and Rio Grande rivers. This may be accepted as an extension southward of District No. 10, with very similar conditions, but a warmer and more southern climate.

Apples

HIGHLY RECOMMENDED—*Dessert, kitchen and market*: Jonathan; Rome Beauty; Wealthy; Winesap. *Kitchen and market*: Oldenburg, Duchess of; Yellow Transparent. *Dessert and market*: Paragon; Plumb Cider; Red June, Carolina; York Imperial (*Johnson's Fine Winter*). *Dessert and kitchen*: Roman Stem. *Market*: Ben Davis; Missouri Pippin.

RECOMMENDED—*Dessert, kitchen and market*: Gravenstein; Rhode Island Greening; Yellow Newtown (*Albemarle*). *Kitchen and market*: Arkansas (*Mammoth Black Twig*); Baldwin; Haas (*Fall Queen, Gros Pomier*); Maiden Blush; Northwestern Greening; Pewaukee; Rams-

dell Sweet. Red Astrachan; Smith Cider; Wolf River. *Dessert and market*: Bailey Sweet; Chenango Strawberry; Fameuse (*Snow*); Hubbardston Nonsuch; Huntsman Favorite; Lawver; McMahon; Porter; Westfield Seek-no-further; White Pearmain (*W. W. Pearmain*); Wine, Hays. *Dessert and kitchen*: Early Harvest; Fall Pippin; Perry Russet, Rambo. *Market*: Cooper Market; Early Cooper; English Russet; Fallwater (*Tulpehocken*); Fall Jenneeting; Gano; Limbertwig; Ralls Genet (*Janet, Neverfail*); Stark; Walbridge (*Edgar Redstreak*); Willow Twig. *Dessert*: Autumn Bough; Benoni; Esopus Spitzenburg; Grimes Golden; Jeteris; Late Strawberry; Sops of Wine; Swaar. *Kitchen*: Keswisk Codling; Quince, Cole.

RECOMMENDED FOR TRIAL—*Kitchen and market*: Mann; Scott Winter. *Kitchen and market*: Arkansas; Maiden Blush; Wetsel; Shockley. *Market*: Fanny; Bledsoe; Gano; Yates. *Dessert*: Carter Blue; Summer Pearmain.

Apples, Crab

HIGHLY RECOMMENDED—*Kitchen and market*: Hyslop; Transcendent.

RECOMMENDED—*Kitchen and market*: Elgin; Yellow Siberian. *Cider, kitchen and market*: Montreal.

RECOMMENDED FOR TRIAL—*Kitchen and market*: Minnesota.

DISTRICT NO. 11

Texas west of longitude 103 degrees and the Pecos river, and New Mexico south of latitude 35 degrees. The Pecos and Rio Grande valleys are the characteristic features of this district. Considerable effort at growing fruit, especially the apple and the hardier *Vinifera* grapes, is being made in many localities.

Apples

HIGHLY RECOMMENDED—*Dessert, kitchen and market*: Jonathan; Winesap; Yellow Bellflower; Yellow Newtown (*Albemarle*). *Dessert and market*: York Imperial (*Johnson's Fine Winter*). *Market*: Ben Davis; Missouri Pippin; Ralls Genet (*Janet, Neverfail*). *Dessert*: Grimes Golden.

RECOMMENDED—*Dessert, kitchen and market*: Rome Beauty; Wealthy. *Kitch-*

en and market: Maiden Blush; Oldenburg, Duchess of; Red Astrachan; Twenty Ounce (*Cayuga Redstreak*); Yellow Transparent. *Dessert and market*: Huntsman Favorite; Red June, Carolina; Shockley; White Pearmain (*W. W. Pearmain*). *Dessert and kitchen*: Broadwell; Early Harvest; Fall Pippin. *Dessert*: Jefferis; Romanite, South.

DISTRICT NO. 12

New Mexico and Arizona north of latitude 35 degrees; Utah; and Western Colorado above 5,000 feet elevation. This district embraces the Continental Divide and the Great Salt Lake, and it also embraces the valley and canyon of the Colorado and the sources of the important streams south of the Missouri and Yellowstone. It affords a great diversity of soils and climatic conditions, and hence a wide range of fruit growing. The species successfully grown within the boundaries of this district range from the *Vinifera* grapes to the hardy ironclad apples.

Apples

HIGHLY RECOMMENDED—*Dessert, kitchen and market*: Bryan, Mrs.; Jonathan; Peck Pleasant; Rhode Island Greening; Rome Beauty; Wealthy; Winesap; Yellow Newtown (*Albemarle*). *Kitchen and market*: Alexander; Haas (*Fall Queen, Gros Pomier*); Maiden Blush; Oldenburg, Duchess of; Roxbury Russet; Smith Cider; Tolman Sweet; Wolf River; Yellow Transparent. *Dessert and market*: Bailey Sweet; Chenango Strawberry; Fameuse (*Snow*); Fulton; Hubbardston Nonsuch; Lawver; McMahan; Ortle; Red June, Carolina; Wagener; White Pearmain (*W. W. Pearmain*); White Pippin; Williams Favorite; York Imperial (*Johnson's Fine Winter*). *Dessert and kitchen*: Broadwell; Early Harvest; Fall Pippin; Golden Sweet; Jersey Sweet; Rambo; Roman Stem. *Market*: Ben Davis; Domine; English Russet; Fallwater (*Tulpehocken*); Fink; Gano; Limbertwig; Missouri Pippin; Ralls Genet (*Janet, Neverfail*); Tefofski; Walbridge (*Edgar Redstreak*); Willow Twig. *Dessert*: Benoni; Esopus Spitzenburg; Grimes Golden; Jefferis;

Sops of Wine; Summer Pearmain. *Kitchen*: Gideon; Keswick Codling.

RECOMMENDED — *Dessert, kitchen and market*: Gravenstein; Northern Spy; Yellow Bellflower. *Kitchen and market*: Baldwin; Clayton; Danvers Sweet; Early Pennock; Hibernial; Kirkbridge; Lowell; Mann; Northwestern Greening; Pewaukee; Ramsdell Sweet; Red Astrachan; Red Stripe; Scott Winter; Summer Queen; Titovka; Twenty Ounce (*Cayuga Redstreak*); Vandevere. *Dessert and market*: Buncombe (*Red Winter Pearmain*); Canada Reinette; Cannon Pearmain; Early Ripe; Golden Russet (N. Y.); Huntsman Favorite; Lady; Paragon; Plumb Cider; Porter; Red Canada; Saint Lawrence; Sutton Beauty; Tompkins King; Washington Strawberry; Westfield Seek-no-further; Wine. Hays. *Dessert and kitchen*: Dutch Mignonne; Fall Harvey; Golding (*American Golden Pippin*); Lady Sweet; Wythe. *Kitchen and cider*: Gilpin (*Little Red Romanite*). *Market*: Bietigheimer, Red; Cooper Market; Early Cooper; Fall Jenneting; Lansingburg; McAfee; Minkler; Nickajack; Stark; Virginia Greening; Windsor; Yates. *Dessert*: Autumn Bough, Sweet; Bullock (*American Golden Russet*); Dyer (*Pomme Royal*); Fall Wine; Family; Hightop Sweet; Late Strawberry; Mangum (*Gulley*); Margaret, Early Red; Newtown Spitzenburg; Primate; Romanite, South; Summer Rose; Swaar. *Kitchen*: Ewalt; Smokehouse; Switzer. *Cider*: Hewes.

RECOMMENDED FOR TRIAL—*Kitchen and market*: Arkansas (*Mammoth Black Twig*).

Apples, Crab

RECOMMENDED — *Dessert, kitchen and market*: Whitney. *Kitchen market and cider*: Montreal. *Kitchen and market*: Brier; Hyslop; Martha; Minnesota; Transcendent; Yellow Siberian. *Dessert*: Van Wyck. *Kitchen*: Red Siberian.

DISTRICT NO. 13

The Dakotas west of longitude 99 degrees; Wyoming; Montana east of longitude 111 degrees; and the British provinces lying between longitude 99 degrees and 111 degrees. The Upper Missouri and

the Yellowstone valleys are the distinctive features of the district. There is perhaps no section of the district in which fruit growing has reached a very high state of development. Leading causes of this condition may be found in the comparatively undeveloped or unsettled state of the country and its great elevation.

Apples

HIGHLY RECOMMENDED—*Dessert, kitchen and market*: Wealthy. *Kitchen and market*: Hibernial; Oldenburg, Duchess of; Red Astrachan; Titovka; Yellow Transparent. *Kitchen*: Gideon; Switzer.

RECOMMENDED—*Kitchen and market*: Antonovka; Mann; Pewaukee; Scott Winter; Wolf River. *Dessert and market*: McMahan; Plumb Cider. *Market*: Tetofski; Virginia Greening.

RECOMMENDED FOR TRIAL—*Dessert, kitchen and market*: Rhode Island Greening. *Kitchen and market*: Northwestern Greening. *Market*: Ben Davis; Bietigheimer, Red.

Apples, Crab

RECOMMENDED—*Kitchen and market*: Hyslop; Martha; Transcendent; Yellow Siberian. *Dessert*: Van Wyck. *Cider, kitchen and market*: Montreal.

RECOMMENDED FOR TRIAL—*Kitchen and market*: Minnesota.

DISTRICT NO. 14

That part of British America lying contiguous to the United States between longitude 111 degrees and 122 degrees; Montana, west of longitude 111 degrees; Idaho; Nevada, and Washington, Oregon and California east of the general coast contour line of 1,000 feet elevation, commencing at the British boundary near longitude 122 degrees and extending southward on said elevation to its intersection with the Southern Pacific Railway in the Upper Willamette valley; thence along the line of said railway to the Sacramento valley; thence east and south on the eastern rim of said valley and that of the San Joaquin at an elevation of 1,000 feet to latitude 35 degrees; thence east on said latitude to the Colorado river. The characteristic features of this district are the Upper Columbia valley and the Sierra

Nevada mountains. An exception to the general recommendation will appear in certain portions of Snake river valley, where the *Vinifera* grapes and other tender fruits succeed.

Apples

HIGHLY RECOMMENDED—*Dessert, kitchen and market*: Gravenstein; Jonathan; Northern Spy; Rhode Island Greening; Rome Beauty; Wealthy; Winesap; Yellow Bellflower; Yellow Newtown (*Albemarle*). *Kitchen and market*: Baldwin; Oldenburg, Duchess of; Red Astrachan; Yellow Transparent. *Dessert and market*: Lawver; Wagener; White Pearmain (*W. W. Pearmain*). *Dessert and kitchen*: Early Harvest; Fall Pippin. *Market*: Ben Davis; Gano. *Dessert*: Esopus Spitzenburg; Grimes Golden; Jefferis.

RECOMMENDED—*Kitchen and market*: Alexander; Arkansas (*Mammoth Black Twig*); Hoover; Maiden Blush; Mann; Pewaukee; Smith Cider; Wolf River. *Dessert and market*: Bailey Sweet; Blue Pearmain; McIntosh; McMahan; Monmouth (*Red Cheek Pippin*); Ortle; Porter; Red June, Carolina; Tompkins King; White Pippin; York Imperial (*Johnson's Fine Winter*). *Dessert and kitchen*: Rambo. *Market*: Missouri Pippin; Walbridge (*Edgar Redstreak*); Willow Twig. *Dessert*: Autumn Swaar; Fall Wine; Late Strawberry; Mother; Newtown Spitzenburg; Swaar.

RECOMMENDED FOR TRIAL—*Dessert, kitchen and market*: Shiawasse Beauty. *Kitchen and market*: Tolman Sweet. *Dessert and market*: Buncombe (*Red Winter Pearmain*); Hubbardston Nonsuch; Wine, Hays. *Dessert and kitchen*: Dutch Mignonne. *Market*: Bietigheimer, Red. *Dessert*: Bough, Sweet; Summer Rose. *Kitchen*: Keswick Codling.

DISTRICT NO. 15

The coast sections of British Columbia west of longitude 122 degrees, and of Washington, Oregon, and that part of California north of about latitude 39 degrees, 30 minutes, and bounded on the east by District No. 14. This district embraces the highly developed fruit-growing sections on Puget Sound, the Lower Columbia, and the Willamette.

Apples

HIGHLY RECOMMENDED—*Dessert kitchen and market* Gravenstein, Jonathan, Northern Spy, Rhode Island Greening, Yellow Bellflower; Yellow Newtown (*Albemarle*). *Kitchen and market* Baldwin, Red Astrachan *Dessert and market* Tompkins King *Market* Ben Davis *Dessert* Esopus Spitzenburg

RECOMMENDED—*Kitchen and market* Oldenburg, Duchess of, Yellow Transparent *Dessert and market* Golden Russet (N Y), Wagener, White Pearmain (*W W Pearmain*). *Dessert and kitchen* Early Harvest *Dessert* Belmont (*Waxen*)

RECOMMENDED FOR TRIAL—*Dessert, kitchen and market* Wealthy *Kitchen and Market* Arkansas (*Mammoth Black Twig*); Wolf River *Dessert and market* Lawver, Red June, Carolina *Dessert and kitchen* Golden Sweet *Market* Gano

DISTRICT NO. 16

The Sacramento and San Joaquin valleys The diversified fruit and nut products of this district are marvelous There are some localities in which the subtropical species are grown to the highest perfection, and others in which the apple, pear, and other hardy fruits and nuts thrive equally well.

Apples

HIGHLY RECOMMENDED—*Dessert, kitchen and market* Gravenstein, Yellow Bellflower; Yellow Newtown (*Albemarle*).

RECOMMENDED—*Dessert, kitchen and market* Jonathan; Rhode Island Greening *Kitchen and market* Alexander; Hoover, Red Astrachan, Smith Cider *Dessert and market* Red June, Carolina; White Pearmain (*W W Pearmain*) *Dessert and kitchen* Early Harvest *Dessert* Esopus Spitzenburg, Swaar

RECOMMENDED FOR TRIAL — *Kitchen and*

market Arkansas (*Mammoth Black Twig*), Baldwin

DISTRICT NO. 17

The coast section of California lying between latitude 35 degrees and about 39 degrees, 30 minutes, and bounded on the east by District No 17 Its characteristics features are the Coast range of mountains, the Russian river the Sonoma the Santa Clara and the Pajaro valleys (*b*)

Apples

HIGHLY RECOMMENDED—*Kitchen and market* Baldwin, Red Astrachan *Market* Ben Davis, Yellow Bellflower, Yellow Newtown (*Albemarle*)

RECOMMENDED—*Dessert, kitchen and market* Gravenstein, Winesap *Kitchen and market* Alexander Hoover *Dessert and market* Red June Carolina White Pearmain (*W W Pearmain*) White Pippin *Dessert* Esopus Spitzenburg Swaar

RECOMMENDED FOR TRIAL—*Kitchen and market* Arkansas (*Mammoth Black Twig*)

DISTRICT NO. 18

* California and Arizona south of latitude 35 degrees The dominant characteristics are the valleys of the Gila the Colorado, the San Gabriel, and the Santa Ana, and the Sierra Madre mountains It includes the celebrated fruit districts of Santa Ana, Riverside Santa Barbara, the Salt river valley, San Diego and many others

^b Districts 15, 16 17 and 18 are particularly adapted to fruit and nut culture Perhaps no portion of the earth's surface is more highly favored in climate and soil and affords a wider range of crop products than that lying within the boundaries of these four districts The commercial value of the fruit and nut products of this section is recognized the world over

* No recommendations worked out for District No 18 The conditions, however, are very similar to those of the extreme southern portion of District No 16 and District No 17 The apple has very nearly reached its southern limit for commercial culture, except in high altitudes — Ed

DATES FOR PICKING AND DATES FOR CONSUMPTION

The following tables were compiled by Mr. Charles L. Hamilton for the Yakima Valley Fruit Growers' Association 1913, showing the dates for picking and the dates when these apples are ripe for consumption. Of course there are differences in the weather of different years making arbitrary dates uncertain.

Winter Apples

VARIETY	COLOR	DATE FOR PICKING		PER CENT OF			USE	COMMON STORAGE MONTH OF MATURITY
		Early Dist.	Late Dist.	3½	4T.	4½		
Akin.....	Dark Red.....	9-20 to 10-10	10-1 to 10-20	2	18	45	35	December
Apple of Com.....	Red Stripe.....	9-20 to 10-15	10-1 to 10-25	1	15	64	20	March and April
Arkansas Black.....	Dark Red.....	9-25 to 10-15	10-10 to 10-30	20	40	35	5	March and May
Bellflower Yellow.....	Yellow Blush.....	8-25 to 9-15	9-5 to 9-25	65	30	5		October and November
Ben Davis.....	Yellow, Red Stripe.....	9-25 to 10-25	10-1 to 10-30	15	50	30	5	February and March
Ben Hur.....	Yellow, Red Stripe.....	9-1 to 9-20	9-15 to 10-10	55	35	10		December
Bismark.....	Red Splash.....	8-20 to 9-10	9-1 to 9-20	65	30	5	2	September and October
Champion.....	Red and Yellow.....	9-15 to 10-15	10-1 to 10-25	60	33	5	3	January
Baldwin.....	Bright Red.....	9-5 to 10-1	9-15 to 10-15	24	43	30	3	November and December
Chicago.....	Dull Red.....	9-10 to 9-30	9-25 to 10-15	15	45	30	10	December
Cox Orange Pippin.....	Cox Orange Pippin, Yellow, Red Cheek.....	9-15 to 10-15	9-20 to 10-20	65	25	10		November and December
Delicious.....	Red and Yellow.....	9-25 to 10-15	10-1 to 10-25	3	57	30	10	February and March
Delaware Red.....	Bright Red.....	8-25 to 9-15	9-1 to 9-25	20	60	15	5	October and November
Fall Wine.....	Bright Red.....	9-1 to 10-1	9-25 to 10-25	2	28	45	25	February and March
Gano, same as Black Ben.....	Red to Dark Red.....	8-25 to 9-20	9-5 to 9-25	5	50	13	2	October, November and December
Grimes.....	Yellow.....	9-15 to 10-10	10-1 to 10-25	35	50	13	2	January
Golden Russet.....	Yellow Russet.....	9-15 to 10-10	10-1 to 10-25	18	42	30	10	December
Hoover.....	Dark Red to Black with Red.....	9-1 to 9-25	9-15 to 10-15	8	32	40	10	November and December
Hubbardston.....	Yellow Splashed.....	9-1 to 9-15	9-1 to 9-25	5	28	40	21	October and November
Hydes King.....	Yellow Splashed with Red and Yellow.....	9-1 to 9-15	9-1 to 9-25	75	20	5		February and March
Ingram.....	Red Stripe.....	9-25 to 10-15	10-1 to 10-20	3	27	40	30	January and February
Jeniton.....	Dull Red.....	9-20 to 10-15	10-1 to 10-25	5	28	40	21	November and December
Jonathan.....	Bright Red.....	9-1 to 9-25	9-15 to 10-25	75	20	5		January and February
Kaighn Spitz.....	Striped.....	9-10 to 10-1	9-25 to 10-15	3	27	40	30	October and November
Kentish.....	Yellow.....	9-1 to 9-20	9-15 to 10-10	10	35	45	10	January and February
King David.....	Dark Red to Black.....	9-15 to 10-5	10-1 to 10-20	Very Small	52	25	5	January and February
Kinnard.....	Dark Red.....	9-25 to 10-20	10-20 to 10-25	18	50	20	15	December and January
Lady Apple.....	Green, Red Cheek.....	9-30 to 10-20	10-10 to 10-30	30	50	30	15	March and April
Mana Apple.....	Green.....	9-20 to 10-20	10-1 to 10-30	5	50	30	15	January and February
Mam. S. Twig.....	Red and Green.....	8-20 to 9-15	9-1 to 9-20	80	18	2	10	September and October
McIntosh.....	Bright Red.....	9-20 to 10-5	10-1 to 10-15	18	42	30	10	November
McMahon.....	Pale Yellow to White.....	9-20 to 10-10	10-1 to 10-15	1	10	39	50	November and December
Mother.....	Red.....	10-1 to 10-25	10-10 to 11-1	1	10	39	50	March and April
Missouri Pippin.....	Red Stripe.....	9-1 to 9-20	9-15 to 10-1	30	40	25	5	October and November
Northern Spy.....	Red Stripe.....	9-1 to 9-20	9-15 to 10-1	30	40	25	5	October and November

Early Apples

VARIETY	COLOR	DATE FOR PICKING		PER CENT OF					USE	MONTH OF MATURITY
		Early Dist.	Late Dist.	3 1/2	4T.	4 1/2	5T.			
								75		
Alexander	Yellow, Red Stripe	8-1 to 9-1	8-2 to 9-7	75	20	5			Culinary	September and October
Astrachan	Green, Red Stripe	7-17 to 8-15	7-22 to 8-25	5	30	65			Dessert and Culinary	August and September
Bailey Sweet	Red	8-17 to 8-20	8-15 to 9-1	10	50	40			Dessert	August and September
Beitingheimer	Light Red	7-19 to 8-10	8-6 to 8-20	90	8	2			Culinary	September
B. Pearmain	Dark Red	9-2 to 9-20	9-8 to 9-26	65	30	5			Culinary	October
Duchess	Red Striped	7-18 to 8-2	7-25 to 8-15	2	18	40			Dessert and Culinary	August and September
Early Harvest	Light Yellow, Blushed	7-18 to 8-3	7-25 to 8-15	8	42	50			Dessert	August and September
Early Ripe	Red		8-20 to 8-28	3	27	40			Culinary	August and September
Fall Orange	Yellow, Red Blush		8-5 to 8-25	10	45	45			Dessert	August and September
Golden Sweet	Yellow	8-1 to 8-20	8-15 to 9-1	12	38	35			Culinary and Dessert	August and September
Gravenstein	Yellow, Red Striped	8-10 to 9-1	8-15 to 9-15	5	35	60			Dessert	August and September
Jeffers	Yellow, Red Striped	8-15 to 9-10	8-25 to 9-15	2	28	40			Culinary	August
Keswick Codlin	Green Blush	8-19		5	35	40			Dessert and Culinary	September and October
Maiden Blush	Yellow, Red Blush	8-10 to 9-1	8-20 to 9-10	2	38	45			Dessert	September
Red Gravenstein	Red	8-17 to 8-25	7-24 to 8-13	2	38	45			Dessert	July and August
Red June	Red	7-18 to 8-3	7-24 to 8-13	2	38	45			Dessert	September and October
Snow	Red	8-9 to 9-10	8-15 to 9-15	75	20	5			Culinary	September and October
Spokane Beauty	Green	7-22 to 8-6	7-30 to 8-10	15	85				Dessert	August and September
Strawberry	Red Striped	8-1 to 8-20	8-5 to 8-30						Dessert	July and August
Summer Queen	Red Striped	7-16 to 7-26	8-20 to 9-11	45	45	10			Culinary	September and October
Tompkins King	Yellow, Red Striped	8-1 to 8-30	7-22 to 9-26	80	15	5			Culinary	September and October
Twenty Oz	Red Striped	7-11 to 9-11	8-2 to 9-5	2	12	50			Dessert and Culinary	September and October
Wealthy	Red	7-25 to 9-1	7-20 to 9-20	85	10	5			Culinary	September
Wolf River	Red Striped	7-11 to 9-1	7-20 to 9-20	Small	20	40			Dessert	July
Yellow June	Yellow	7-27	7-22 to 8-10						Dessert and Culinary	July and August
Yellow Trans	Yellow	7-11 to 8-1	7-22 to 8-10						Dessert and Culinary	July and August

Crabs

TIME PICKED IN EACH DISTRICT, AS SHOWN BY THE FOLLOWING:

VARIETY	White Bluffs, Hanford and Kennewick	Parker and Donald	North Yakima	Buenna, Zillah, Granger, Sunny-side, Donald, Grand, Prosser	Selah Naches	SIZE	COLOR
Florence			8-3 to 9-3			Small	Yellow Striped
Hyslop			8-10			Medium	Deep Red
Siberian			8-16 to 9-3	7-31 to 9-1	8-10 to 8-18	Small	Yellow Blushed
Transcendent	7-25 to 8-10	8-2	7-26 to 8-22	7-26 to 8-12	8-12 to 8-18	Medium	Yellow Blushed
Whitney		8-9 to 8-14	7-31 to 8-22	7-31 to 8-2		Very Large	Yellow, Red Striped

Central Washington Dates

The dates between which the leading apples of North Central Washington are in prime condition in common storage are as follows:

Rome Beauty, January 1 to March 1.
Jonathan, December 15 to February 1.
Yellow Newtown, March 1 to May 1.
Spitzenburg, January 15 to March 15.
Delicious, December 1 to February 15.
Winesap, February 15 to June 1.
Palouse, November 1 to January 1.
Yellow Bellflower, December 1 to Mar. 1.
W. W. Permain, February 1 to Mar. 25.
Winter Banana, December 15 to Feb. 15.

ELIAS NELSON

DESCRIPTIONS OF VARIETIES

The following descriptions of varieties are some of them from the personal observations of the writer; but mainly they are taken from the descriptions given by S. A. Beach in the "Apples of New York." The conditions in New York and the Pacific Northwest are so different that it often makes a great difference in the form, size, color and flavor of apples. Where we have known this to be true we have modified the descriptions of fruits given by Beach. With the information accessible to him at the time, his work is most accurate and most complete. Due credit is given him in this connection.

GRANVILLE LOWTHER

Alexander

The Alexander originated in Russia; was introduced into England in 1817; but the exact date of its introduction into the United States we are not able to determine.

The fruit is very large, attractive, red or striped, coarse in texture, rather good in quality, better for culinary purposes than for dessert. It is large, uniform in size and shape, roundish, slightly conical, symmetrical. Skin moderately thick, tough, smooth, glossy, somewhat waxy, greenish or pale yellow deepening to orange in the sun. In the arid regions of bright sunshine, it is often of a deep red color.

The tree is hardy, vigorous, moderately productive, but is more subject to blight than some other varieties. It has long branches, upright, spreading to roundish top, twigs stout with large terminal buds; bark brown mingled with olive green.

For market the fruit is in good demand from September to the first of November, although it inclines to crack at the stem and calyx, and there is considerable loss by premature dropping.

Arkansas Black

The Arkansas Black has sometimes been called the Arkansas, but the two varieties are unlike, and should not be identified with each other. The Arkansas belongs to the Winesap family. Both originated



Arkansas Black.

Photo by Marted.

in Arkansas, but they are differently colored and of different quality. The Arkansas Black is the most deeply colored, most polished and most beautiful of the apples grown in this country. On account of its dark red color, its solid flesh and superior keeping and shipping qualities, it is desirable. It looks well on exhibition, and sells for good prices; yet it is not a good apple for dessert purposes nor is it a heavy bearer.

It originated in Benton county, Arkansas, about 1870; the first description is given by Van Deman in 1886.

Tree moderately vigorous; branches long, slender. Form upright, spreading, rather open. Twigs short, stout; internodes short. Bark dark reddish brown, mottled with scarf skin, pubescent. Fruit as grown in the Middle or Eastern states medium or rather below medium; but as grown in the Pacific Northwest, it is medium or above medium. Form nearly round, slightly elongated. Calyx tube conical, approaching funnel form. Stamens marginal.

Flesh decidedly tinged with yellow, very firm, rather fine grained, crisp, moderately juicy, sprightly subacid, and by some considered good to very good. In this particular we would differ somewhat from these statements. We have already said "it is not a good apple for dessert purposes." Perhaps this may be a little overstated, inasmuch as the apple is so late in maturing that it is seldom offered for sale in its proper season. Its season is said to be "December to April," but our observation is that it is never fit for use until April, and that its proper season is April to May.

Baldwin

The Baldwin is preeminently the leading variety in the commercial orchards of New York, New England and certain parts of Canada. Also it is one of the leading varieties of Michigan and Northern Ohio. In the South and Southwest it is not a desirable apple, because it ripens too early to be a good winter variety, and because it does not attain so high a quality and flavor as in other climates. It does fairly well in the Pacific North-

west, but is not one of the best varieties, and it seems to be conceded that it cannot be grown successfully in these districts in competition with the Northeastern states where it reaches its highest perfection.

The tree is a strong grower, long lived and vigorous. It is somewhat slow in reaching maturity, but when mature it bears abundantly.

Historical. This fruit originated as a chance seedling on the farm of John Ball, Wilmington, Massachusetts, about 1740, but it was given the name Baldwin because it was largely propagated by Col. Baldwin.

Tree large, very vigorous, branches large, strong. Form upright, spreading, eventually becoming rather round and somewhat dense. Twigs long, straight or somewhat crooked, moderately stout; internodes medium to long. Bark brownish red, mingled with olive green.

Fruit sometimes large to very large; usually above medium; pretty uniform in size. Form roundish to conic, varying to roundish oblong. Skin tough, smooth, light yellow or greenish, blushed and mottled with bright red; sometimes approaching a deep red. Flesh yellow, firm, moderately coarse, crisp, tender, juicy, agreeable subacid, very good. Season March or April; November to December in the Northwest. Later in cold storage.

Ben Davis

The Ben Davis is perhaps as widely distributed as any other variety of apples grown. It is not very successful in the extreme northern part of the United States, but from the Atlantic to the Pacific, between the parallels of 32 degrees and 42 degrees it is the most important variety grown. It is preeminently successful in the Virginias, Kentucky, Tennessee, Illinois, Missouri, Arkansas, and portions of the adjoining states. Its great popularity seems to be largely on account of its good keeping qualities, its good shipping qualities, the vigor of growth of the tree and its regular heavy bearing.

Historical. The origin of this apple is not definitely known. It is supposed, however, to have originated about the begin-

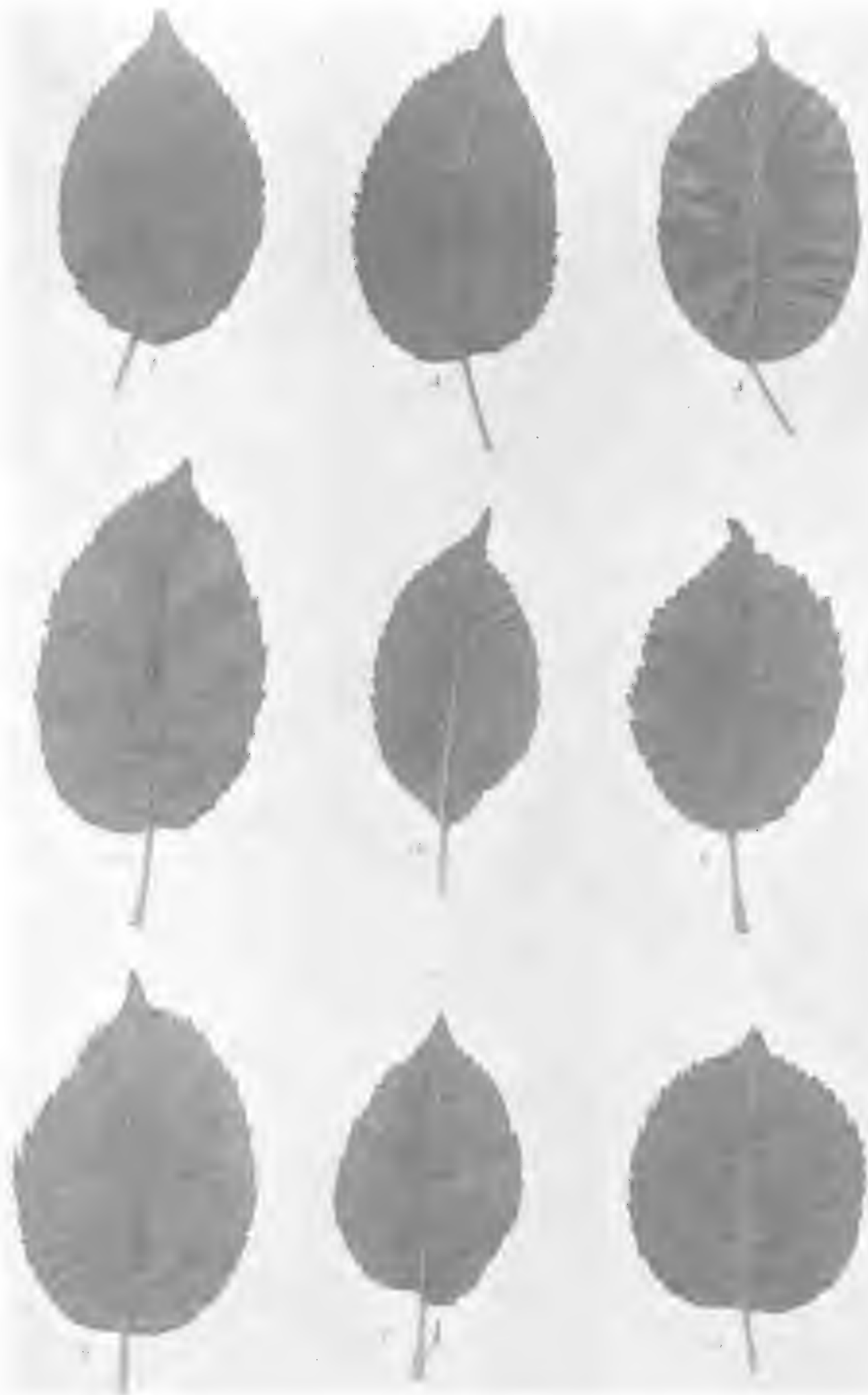

Apple Leaves, Showing the Various Types of Leaf of Certain Standard Varieties. It is possible for those familiar with these characters to identify varieties, within certain limits, in the nursery row and before the trees come into bearing. 1, Arkansas Black. 2, Yellow Bellflower. 3, Ben Davis. 7, Grimes. 8, Jonathan. 9, King David. 13, Rome Beauty. 14, Spitzenburg. 15, Stayman Winesap.

—Selected by W. S. McLain.

ning of the nineteenth century. This view is supported by the fact that before the Civil War it had spread through the states of Virginia, Kentucky and Tennessee, and following the routes of migration had been carried into Southern Indiana, Illinois, Missouri and Arkansas.

Tree medium size, rather rank grower, especially when young, forming coarse strong wood which seldom breaks under heavy crops. Branches strong with numerous rather short laterals or spurs, often inclined to bend or droop. Form upright becoming roundish, and in old trees rather spreading. Bark bright, rather dark brownish red, continuously mottled with fine scarf skin, pubescent.

Fruit usually above medium to large. Form roundish varying from somewhat conical to somewhat oblong, broad, rounded at the base, often somewhat elliptical or slightly irregular, sides somewhat unequal; rather uniform in shape and in size. Skin tough, waxy, bright, smooth, usually glossy, clear yellow or greenish. Season from January to June.

Buckingham

This variety originated in the South, some say in Virginia and others say in North Carolina; but it seems not well adapted to the northern sections of the United States. It has long been known in New Jersey, Virginia and westward in Southern Ohio, Southern Indiana and other parts of the Middle and Southern states.

The tree is a moderate grower, twigs short and rather slender; bark smooth, clear, reddish brown mingled with olive green.

Fruit large; form oblate to roundish, somewhat irregular, sides sometimes unequal. Skin thick, tough, pale yellow or pale green, washed and mottled with red, striped and blushed with carmine. Flesh tinged with yellow, moderately firm, coarse, rather tender, crisp, juicy with distinct aroma, mild subacid, fair to good. It is a good keeper for use from November to April.

Delicious

The Delicious is one of the new varieties



Ben Davis.

Matted Photo.

not yet very well known, and its market value not well established. At the present time it sells for higher prices than almost any other apple in the markets; but the fear of growers is, that it will not continue to do so. Perhaps nothing but time can determine this question. Yet the apple has many desirable characteristics.

The tree is a vigorous grower, an early and heavy bearer. The apples are large, ranging from 72 to 140 per box. The color is a yellowish red, sometimes striped and sometimes deep red. Form oblong conical, with the calyx end irregular in form. The flavor is a mild subacid, very pleasant to the taste and very desirable for dessert. It is not so highly regarded for cooking, although it is a very good baking apple. For market its standard has not been well established, but we have seen them in the Eastern and Southern markets shipped from the Pacific Northwest and received in prime condition.

For keeping in storage the same lack of unanimity of opinion prevails as in the case of marketing. We have kept them in our own cellar in what is termed "common storage," in good condition until March.

It originated in Iowa and has been largely propagated in Missouri, and the Pacific Northwest. It varies considerably in size, color and shape, in response to its environment.

Early Harvest

The Early Harvest is in color pale yellow, sometimes with a faint blush, tender, sprightly subacid, and very good in quality. It is desirable as an early variety for home use and is excellent either for cooking or dessert. It is not desirable as a market variety, because it easily bruises; fruit keeps but a short time and produces a considerable percentage of small, undersized and unmarketable fruit.

Historical. The origin of the variety is unknown, but it is supposed to have originated in America, and is known to have been in cultivation for more than one hundred years.

The tree is a medium size, moderately vigorous. Form upright, spreading, roundish, open. Twigs moderately long, curved,

rather stout; internodes short. Bark dark brown, with some olive green, lightly streaked with scarf skin; slightly pubescent, or hairy.

Season depending on the latitude and the elevation, but generally ripe in July and August.

Esopus Spitzenburg

The Esopus Spitzenburg, commonly known as Spitzenburg, is the standard of excellence for all apples of the Baldwin class. In fact, it is one of the best, if not the best apple, produced in America, when all of its qualities and uses are considered.

It is well colored when normally developed, unexcelled in flavor, excellent for dessert, and one of the very best for culinary purposes. It keeps well in cold storage, ships well, has for many years been one of the very best market varieties, and is often packed in fancy boxes and sold for high prices. On the other hand, the fruit is susceptible more than the average, to attacks of scab fungus, as are the blossoms and the foliage. It is not a heavy bearer, and the tree is tender; but it brings such good prices that the net profits are better than those from most other varieties.

The Spitzenburg originated at Esopus, Ulster county, New York, date not known, but it is more than one hundred years old.

The tree is rather a slow grower, and comes into bearing later than most other varieties. The lateral branches are slender and somewhat drooping. Form open and spreading, twigs long and slender. Bark dark, rather clear reddish brown and dark green, finely mottled with thin gray scarf skin; leaves inclined to be narrow; foliage not dense.

Fruit medium to large; form rather broad and flat at the base, varying from oblong rounding toward the cavity to roundish ovate, or roundish inclined to conic; somewhat irregular and obscurely ribbed. Skin tough, sometimes waxy, slightly roughened by the russet dots. Flesh tinged with yellow, firm, fine, crisp, tender, juicy, aromatic, subacid. Season from November to February; but in cold storage may be held until June.

Fall Pippin

The Fall Pippin has, by a considerable number of persons, been called the Holland Pippin, which it very much resembles, but from which it differs mainly in the fact that its fruit ripens from the middle of September until about the first of November, while the fruit of the Holland Pippin ripens almost a month earlier.

The fruit of the Fall Pippin is large, tender, rich, very good in quality desirable for culinary purposes, and when fully ripe is an attractive yellow color.

The tree is a strong grower, hardy and long lived, eventually becoming very large. It is spreading or roundish, with long branches, twigs moderately long, curved, stout and with large terminal buds. Bark dark reddish brown, somewhat tinged with green, heavily coated with gray scarf skin.

The flesh of the fruit is whitish, tinged with yellow, moderately firm, rather fine, tender, very juicy, agreeable subacid, somewhat aromatic, very good. The skin is thin, smooth, at first greenish yellow but becoming a clear yellow, and in the

arid regions of bright sunshine, having a considerable blush of red.

In the northern latitudes, especially in the higher altitudes, the fruit will keep nicely until January.

Fameuse

Fameuse is in its season one of the most desirable of dessert apples. It is very beautiful in appearance; the flesh is white, tender, excellent in flavor and quality for dessert. But it is decidedly inferior to other varieties in its season for culinary purposes. Its market season in the Northern states, is from October to the holidays, and it usually sells for good prices. It is more susceptible than most other varieties to apple scab fungus, but since the adoption of spraying methods this is kept well under control. The tree is of medium size, a moderate grower, hardy, healthy, rather long lived, and a reliable cropper yielding good to heavy crops biennially, sometimes annually.

Historical. The history of the Fameuse is uncertain; but the preponderance of evidence seems to be that it originated in Canada among the French colonists on the



Esopus Spitzenburg.

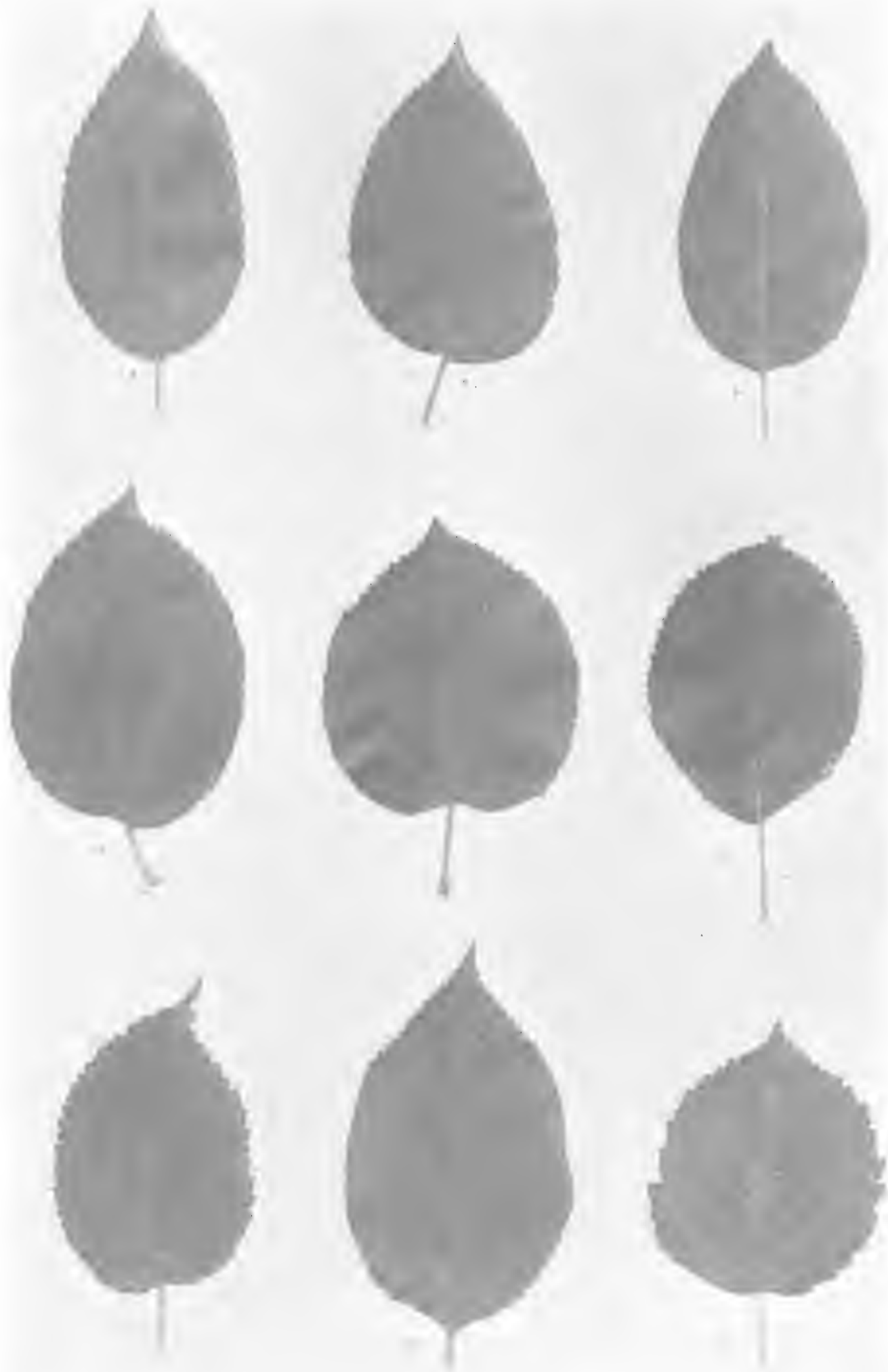

Apple Leaves, Showing the Various Types of Leaf of Certain Standard Varieties. It is possible for those familiar with these leaf characters to identify varieties within certain limits, in the nursery row and before the trees come into bearing. 4, Black Ben. 5, Delicious. 6, Gravenstein. 10, King. 11, McIntosh Red. 12, Red Astrachan. 16, Wagener. 17, White Winter Pearmain. 18, Winesap. —Selected by W. S. McLain.

eastern shores of Lake Champlain. It has one peculiar characteristic, which made its dissemination more rapid than that of most other varieties, and that is, it produces reasonably true to type, from the planting of the seed. However, there is more tendency to variation by planting from seed than from the ordinary method of grafting or budding. As a result there have been a number of varieties originated from the Fameuse, among which are Bloom, Brilliant, Canada Baldwin, Fameuse Noire, Fameuse Sucre, La Victoire, Louise, McIntosh, Hilaire, Shiawassee.

Fruit small to medium size, roundish, sometimes a little oblate, regular, uniform symmetrical. Cavity acute, moderately deep, rather wide, often gently furrowed, sometimes partly russeted; but generally smooth and greenish red. In the Northwest it is often a deep red.

Gano

The Gano belongs to the Ben Davis family, which the tree very closely resembles. It is more highly colored than the Ben Davis, and is slightly better in quality. It is less striped, and in the arid regions is a beautiful light to rather deep red, is very attractive in appearance, and because of its beauty will sell from the fruit stands for much higher prices than the Ben Davis. It is a good keeper, a good shipper, and a good bearer.

Historical. The origin of this apple is unknown. It was brought to notice in Missouri about 1880, and disseminated under the name Gano. By many it has been regarded the same as the Black Ben Davis. It certainly resembles the Black Ben very closely; but the preponderance of evidence seems to be that these are two varieties of distinct origin.

The tree is moderately vigorous, branches long moderately stout, inclined to droop; laterals willowy, short, slender. Form like that of the Ben Davis, upright, drooping, rather dense. Bark bright brownish red, mingled with olive green, lightly overcast with mottled, and streaked gray scarf skin; pubescent.

Fruit medium to large. Form roundish conic, usually regular, symmetrical; uniform in size and shape. Stem medium to long slender. Cavity acute deep, rather broad, symmetrical, sometimes rather furrowed or compressed.

Flesh whitish, slightly tinged with yellow, firm, moderately tender, rather coarse, moderately crisp, juicy, mild, subacid.

Season about the same as that of the Ben Davis, extending from December to May, depending on the latitude and altitude in which grown.

Goal

The Goal apple, earlier known as the Albany, was propagated first by G. W.



Gloria Mundi.



Spokane Beauty.

(Much Reduced)

Matted Photo.

Pemberton, Albany, Oregon. It is something like the Gravenstein in flavor, except that is not so acid. This fact, according to the propagator, makes it a little better than the Gravenstein. However, this would be a matter of taste, and the general public might not be of the same opinion. It has been suggested that the original tree was a cross between the Gravenstein and the King. The apples are large like the King and the young trees resemble those of that variety. The apples sometimes weigh as much as 16¾ ounces; but in general, they are good four-tier apples. One peculiar characteristic of this variety is, that it begins to ripen fruit along in the early part of July, and from that time on until December. Any time between July and December ripe fruit can be gathered, and at the same time there will be fruit in all stages of development. The tree bears heavily, is very hardy, and its long continued blooming period is an important feature where there is danger from late frosts.

A very interesting account is given by the owners of this tree which illustrates an important variation. Going out into the orchard to spray at about the usual time in the spring of 1913, they found this tree already in bloom. It was sprayed however, and the blossoms all died.

Two weeks later, the tree was again found in full bloom; and that year it produced a heavy crop of apples. This tree was discovered on the farm of David E. Junkin, Linn county, Oregon. The account here given is by the proprietor of the Albany Nurseries, Oregon.

Gravenstein

The Gravenstein is one of the best apples in its season. It is good for dessert and has no superior for culinary purposes. The crop ripens continuously during a period of several weeks, and for that reason should have two, three, or perhaps four pickings. It is ready for use from the last of August to the first of November, depending on the latitude and altitude in which it is grown. Being regarded the best apple in its season, the fruit often sells for high prices in the markets. The tree is not especially hardy; but comes into bearing early and is quite productive.

Historical. In Hovey's account published in 1851, it is said, "The origin of the Gravenstein remains in some doubt." It is said to have been originally found in the Duke of Augustinberg's garden at Gravenstein in Holstein, and that the original tree was growing there in the middle of the last century (1750). Another statement is that it derived its name from being found in the garden of the castle of Grafenstein in Selswick; and Deil says



Quince Apple.

Apple of Commerce.

Matted Photo.

that it was supposed by some to have been introduced from Italy. Be this as it may, it is a common apple throughout Germany and Sweden, and was received from thence into the English colonies.

Fruit large to above medium, fairly uniform in size but not in shape. Form oblate to roundish, somewhat irregular, broad at the base, slightly angular about the basin. Skin thin, tender, slightly rough, greenish yellow to orange yellow, overlaid with broken stripes of light and dark red. Dots few, small, light. Prevailing effect yellow striped.

There are several instances where bud sports have originated highly colored red fruit like the Gaucher, Leroy, Red Gravenstein and Banks.

Grimes Golden

The Grimes Golden is probably as well adapted to various parts of the apple growing districts of the United States as any other, with perhaps two or three exceptions. However, it does better in the central sections than in the extreme south or north.

The fruit is a beautiful golden yellow, and is perhaps the very best yellow variety in its season, which will range from the middle of August to the middle of October, depending on the latitude and altitude in which it is grown. It may be kept, however, until late in winter, if grown in the extreme North, or kept in cold storage.

It originated in West Virginia, and fruit from the original tree was sold to New Orleans traders as long ago as 1804.

Tree moderately vigorous; branches short, stout, curved, crooked. Form upright, spreading, inclined to droop, rather dense. Bark dull brownish, rather lightly mottled with scarf skin; pubescent in spots and at the tips.

Fruit medium to large. Form roundish oblong, often flattened at the ends, sometimes inclined to conic, pretty regular, sometimes obscurely ribbed, symmetrical, uniform. Stem short to medium. Cavity broad, deep, acuminate. Skin tough, somewhat rough, clear deep yellow with scattering pale yellow or russeted dots. Flesh yellow, very firm, tender, crisp, mod-

erately coarse, juicy, subacid, aromatic, sprightly, very good to best.

Hibernal

The Hibernal is a Russian variety that is proving valuable in the Upper Mississippi valley and the Middle Northwest, because of its ability to withstand the rigorous climatic conditions of those regions. Hansen says of it: "This variety represents what is probably the hardiest type of the Russian race of apples. There are several sorts closely resembling or almost identical with the Hibernal. Tree vigorous, very spreading, productive. The strong spreading growth makes it especially desirable as a stock for top-grafting probably the best we have at the present time. Fruit large, irregular, oblate to roundish oblate conical; surface greenish yellow, with a dull bronze mixed red on the sunny side, with a few dull crimson splashes; dots white, minute, obscure, often some large russet dots; cavity large, regular, medium, deep, with a large patch of russet radiating out irregularly nearly over the entire base; this is a marked characteristic. Stem medium, often short, basin narrow, rather shallow, wrinkled; calyx half open or open. Core closed, meeting; tube funnel shaped, stamens median. Seeds few; flesh acid with some astringency, juicy, good for cooking. Early winter."

Macoun reports: "Flesh yellowish, crisp, tender, juicy, acid; core small, quality above medium; season September to November. Tree very hardy, a strong spreading grower, and very productive. Although not a good dessert apple, it is fine for cooking; on account of its great hardiness and productiveness it is one of the best of the Russian apples."

Hubbardston

The Hubbardston is perhaps as varied under different conditions as any variety grown. It is therefore difficult to describe because a description suited to one section would not be suited to another. These differences are particularly manifest in the vigor of the tree; color of the fruit; size of the fruit; degree of smoothness or russeting of the skin; flavor and keeping qualities. Because of this tendency to va-



Marted Photo.

Mamm.

Mammoth Black Twig.

riation it has come in different parts of the country to be known by different names, such as American Blush, Van Vleet and Orleans.

It is a heavy bearer, requires thinning and comes into bearing at an early age. The tree is not especially hardy, in fact, it is rather tender, and is susceptible to attacks from diseases, especially apple canker.

Historical. The Hubbardston had its origin in Hubbardston, Massachusetts. As early as 1832 Kenrick referred to it as one of the most desirable varieties known in Eastern Massachusetts.

Jefferis

Fruit of medium size, yellow, blushed and splashed with red. Flesh tender, mild, subacid, delicious. It begins to ripen in September and continues in season till early winter. As a commercial apple, it is not good later than the last of October, in the Northern states, and it ripens earlier in the Middle and Southern states. It is a good variety for the home orchard, but not for commercial planting, because it ripens unevenly, is likely to be deficient in size, and is not specially attractive in color. The tree is rather a vigorous grower, hardy, healthy, comes into bearing moderately early and is a reliable cropper.

Historical. This variety originated with Isaac Jefferis, Newlin township, Chester county, Pennsylvania. It was named after the originator by the committee of the

Pennsylvania Horticultural Society which awarded this variety the premium for the best seedling apple exhibited in 1848.

Jonathan

The Jonathan belongs to the Spitzenburg class. It is very beautiful, of a brilliant red color, highly flavored and of excellent quality for either dessert or culinary purposes. It excels the Spitzenburg in productivity, hardiness and vigor of the tree, and is adapted to a wider range of territory. In form the fruit is roundish conic to roundish ovate, often somewhat truncate, regular, rather uniform in shape and size. Skin tough, thin, smooth, pale bright yellow overlaid with a lively red, striped with carmine. In the irrigated regions it often takes on a deep or dark red color. Flesh whitish or somewhat yellow, sometimes with a tinge of red, firm, moderately fine, crisp, tender, juicy, very aromatic, sprightly subacid, very good to best.

Its season is from September to first of November for picking and marketing, depending on the sections in which grown, but may be held in storage until January and February, if grown in the colder higher altitudes. I have seen Colorado Jonathans in the markets of Texas in prime condition in February; but when grown in the Ozarks, they could not be marketed later than December.

Historical. The first published account which we find, is that given by Judge J.



Stayman Winesap.



Jonathan.

Matted Photo.



Lawyer. *Marsted Photo.*



Hubbardston



Ruby.

Buel of Albany in 1826, in an article the "Utility of a Descriptive Catalogue of Orchard Fruits." He listed the Jonathan as "Esopus Spitzenburg, New," with the synonym "Ulster Seedling." It originated on the farm of Mr. Philip Rick of Woodstock, Ulster county, New York. The name Jonathan was assigned to it by Judge Buel in honor of Jonathan Hasbrouck, by whom his attention was first called to the variety.

Longfield

The fruit of the Longfield is below the medium in size, but is decidedly attractive in appearance for a yellow apple, being clear waxen yellow, lightly blushed with bright red. Its flesh is crisp, white, fine, very tender and of pleasant quality. It is classed among the fancy dessert apples and is good for cooking. In marketing this fruit it is necessary to handle it with more than ordinary care, because its texture is so tender, and its color so delicate, that it shows bruises very readily. Its season is September and October; but in cold storage it is sometimes held until winter, especially if grown in the North.

The tree is a moderate grower, very hardy and very productive, and requires much care in thinning, in order that the fruit may not be deficient in size. Form roundish or spreading, dense, rather low. Twigs medium to stout, large terminal buds, internodes short. Bark dark brown, lightly streaked with scarf skin; pubescent.

Historical. The Longfield was imported from Russia by the United States department of Agriculture in 1870. Later it was imported from various European sources for the Iowa Agricultural College. It is now frequently listed by nurserymen, and is being planted to a limited extent in most of the Northern States.

Maiden Blush

The Maiden Blush is one of the very best apples for use in September and October. It is pale yellow, with crimson cheeks, flesh white, sprightly and good in flavor when fully ripe. It is a good market variety, especially good for cooking, and usually sells above the average

of apples in its season. It does not mature uniformly, and requires several pickings to get the best results.

The tree is moderately vigorous, form spreading, twigs long and curved, internodes short, bark brown or reddish brown, lightly mottled with scarf skin.

Fruit medium or above in size, form oblate, inclined to conic, regular and symmetrical. Stem short, medium, rather slender. Cavity large, acute to obtuse, medium to wide, moderately deep to shallow. Calyx medium sized, closed.

Historical. Coxe described this variety in 1817 as very popular in the Philadelphia market, and the best variety of its season for evaporating. In the American Pomological Society's Catalogue of Fruits it is reported as either wholly successful or successful in nearly all the important apple growing districts of the United States.

McIntosh Red

This fruit is a bright red color and very attractive in appearance. It belongs to the Fameuse group, but is adapted to a wider range of localities than the other varieties of this group. The flesh is very tender, perfumed and delicious. Skin smooth, readily separating from the flesh, clear whitish yellow or greenish washed and deeply blushed with bright red and striped with carmine. In the Rocky Mountains States and in the Pacific Northwest it becomes in many cases a deep, dark red, overspread with a thin lilac bloom. Form roundish to somewhat oblate, regular or faintly ribbed, obscurely angular. Stem short, moderately slender. Cavity large acuminate or somewhat acute. Calyx small, closed or partly open. This variety originated on the McIntosh homestead, Matilda township, Dundas county, Ontario, where Allen McIntosh began its propagation in the nursery about 1870. It originated as a seedling, and is now widely distributed throughout the northern half of the United States. It is very good for dessert, sells well in the markets, and brings good profits.

Season, October to December or, when grown on high altitudes, may be marketed until January.

Missouri Pippin

The Missouri Pippin is one of the well known market apples in the middle states. It originated in Missouri on the farm of Brinkley Hornsby, Kingsville, Johnson county, Missouri, from seed planted about 1840. Shortly after the Civil War it began to be disseminated outside of the locality of its origin, and its cultivation spread with such rapidity that in a few years it had been planted in Missouri, Kansas, Illinois and adjacent states. The good degree of hardiness and vigor which it possesses, the ease with which it is propagated in the nursery, and particularly the habit of bearing early and abundantly, were the qualities which recommended it to the growers of this section. However, the fruit is not first-class for dessert, and when commercial fruit growing came to be an important industry it was found that it was not a profitable variety as compared with other commercial fruits. It was also discovered that the tree was short lived, and would seldom bear a good quality of fruit after the age of 20 years. The popularity of the Missouri Pippin, therefore, rapidly waned, and at this date comparatively few of this variety are being planted.

Tree moderately vigorous with long, slender, curved branches, characteristic on account of its numerous slender twigs and general crab-like appearance. Form upright, becoming roundish or rather spreading. Bark dark brown, mottled with heavy scarf skin, pubescent. Fruit medium in size. Form roundish, somewhat inclined to conic. Stem medium in length, rather slender. Cavity acute to nearly acuminate, moderately wide, rather deep, faintly russeted. Calyx medium in size, closed or nearly so.

Skin thick, tough, rather glossy, thinly coated with grayish bloom. The color ranges from a greenish or pale yellow, to red striped and deep red. Season October to January.

Northern Spy

The Northern Spy is perhaps the very best apple for Michigan, being peculiarly

adapted to the soils of that region. In New York it ranks third, being superseded by the Baldwin and Rhode Island Greening. When it is grown where it is best adapted it is a first-class apple. In the Pacific Northwest it does not do so well as in some other sections of the country. The fruit is large, red, tender, juicy, crisp and good for dessert or for culinary purposes. It has a well established reputation, and because of its high quality often sells for good prices. Its season is November and December. It is susceptible to the attack of blue mold, if kept in storage, and is easily bruised in handling.

Tree very hardy and healthy, growing to a large size, with large vigorous branches, long and stout, curved. Form upright, roundish, slender laterals, somewhat inclined to droop. Bark dark brownish red mingled with olive green lightly streaked with thick scarf skin, heavily pubescent.

Historical. The Northern Spy originated in a seedling orchard at East Bloomfield, New York. The trees were planted by Herman Chapin about 1800, but attracted very little attention until about 1840, when it began to be more widely recognized as a valuable variety, and to be more extensively cultivated.

There are the following peculiarities of the tree that should be considered in selecting commercial varieties. First, it is more than ordinarily susceptible to "apple scab fungus." Second, it comes into bloom remarkably late, and this fact often prevents it from being injured by spring frosts, when earlier blooming varieties are killed. Third, it often produces many small apples which are seedless, the result of improper fertilization of the blossoms. The tree is resistant to woolly aphis.

Oldenburg

The Oldenburg, generally called the Duchess of Oldenburg, is a Russian apple. In European nurseries is called Charlmowsky and Borowitsky. It was brought to this country from England, and because of its extreme hardiness

became popular with the settlers on the prairies of Illinois, Iowa, and other north central states where the winters are severe. It is of good size, attractive in appearance, and is one of the most valuable Russian varieties ever brought to this country. It ripens in the northern states about the last of August and the first of September, and is generally highly esteemed for home use on account of being a good cooker. The fruit is perishable and does not stand shipment well, but when carefully handled it may be considered a fair commercial variety for its season.

The tree is vigorous and hardy, but inclines to slow growth with age. Its form is at first upright, spreading; but later becomes roundish; twigs moderately long, curved, slender, with dark brown bark.

Fruit medium to large, average above medium, uniform in size and shape. Form roundish to oblate, regular, symmetrical. Skin moderately thick, tender, smooth, pale greenish yellow or pale yellow, almost covered with irregular splashes and stripes of bright red mottled and shaded with crimson; prevailing effect, red striped. The flesh is tinged with yellow, rather firm, moderately fine, crisp, tender, juicy, sprightly subacid, aromatic.



Rambo.

Rainier

Historical.—The original 54 trees were planted some 30 years ago by a man now dead and, after a very thorough investigation, no information was found that would lead to a knowledge of the source of the original scions or nursery stock. Up to the time the present owner, W. W. Scott, came into possession of the orchard the fruit was marketed under various names. The gentleman owning the orchard at that time had decided to graft over the trees to Spitzenburgs, and when Mr. Scott moved on to the place he found that the Spitzenburg scions had been grafted in. When it came time to prune Mr. Scott was undecided whether to leave the Spitzenburg scions or the original trees but, owing to the fact that it would take several years for the scions to come into bearing and that Mr. Scott was no longer a young man, he at last made up his mind to leave the original trees and take a chance on the fruit. The name "Rainier" was selected as being suggestive of the locality.

Tree.—The tree is a vigorous grower and is inclined to be spreading, therefore, capable of bearing a heavy crop. Twigs quite long and slender. Bark light and showing a few dots.

Fruit.—The fruit is oblong and slightly inclined to conical. Flesh, yellowish with practically no grain. Probably better described as "buttery." Skin, yellowish green underneath with an over-coloring of dark red. Slightly streaked. Quality, much resembling the Delicious, but a much better cold storage apple. Fruit picked during October, 1912, was placed on the table at the banquet of the International Refrigerator Congress, Chicago, in September of 1913, in perfect condition. The Government pomologists say it is the one apple which does not show some defect from cold storage. Scald is unknown, decay practically so. Eating quality seems to improve rather than deteriorate. Should also say in regard to the shape of the fruit that it shows the five distinct points at the blossom end which is so distinctive of the Delicious.



Rainier.

Season.—In common storage from October to February. In cold storage from October to October.

Red Astrachan

This is an early summer apple, medium size, yellowish red, some parts being a dark red, and causing the apple to present a striped appearance, and is also overspread with a bluish bloom. It is good for culinary purposes before it becomes fully ripe, so that it is valued for home use.

The tree is of medium size, a good grower, moderately long lived, comes into bearing young and produces well. The crop matures unevenly and in order to save the fruit it is important to give sev-

eral pickings. The fruit is tender and perishable, and for this reason not well adapted to commercial purposes.

Historical. Hogg states that the Red Astrachan was imported into England from Sweden in 1816. It was one of the first Russian apples imported into America, and was received by the Massachusetts Horticultural Society from London, England, about 1835; but this was not the first importation, for the same year fruit of this variety grown in Massachusetts was exhibited at the meeting of the Massachusetts Horticultural Society.

Red June

The Red June is a deep red apple, and derives its name because in North Caro-

lina, where it originated, it ripened in June. It has a subacid flavor, flesh tender.

The fruit is small to medium, roundish, ovate, rather inclined to be oblong, sides unusually unequal, cavity small, acuminate to acute, calyx medium to large, leafy, closed or sometimes a little open. The skin is tender, smooth, and variable in color. In some sections of the East the color is a yellowish or greenish red, in others it is a deep red. In the irrigated regions of the Northwest, it is always red.

Rhode Island Greening

The Rhode Island Greening does not do the best in the Pacific Northwest and the Rocky Mountain states, but is at home in New England, New York and Pennsylvania. In the northeastern and north central states it is probably unsurpassed as an apple for dessert and culinary purposes. As its name indicates, the apple is green in color; is generally a deep grass-green in early autumn, but later as it ripens develops a more or less yellowish color. In some sections of the country it has a dull blush and occasionally develops a rather bright red cheek, but never striped. Generally it is productive and an annual bearer. The fruit has a recognized standard in both domestic and foreign markets and sells at good prices.

The tree is long lived and eventually becomes large, although it is not an exceptionally rapid grower. It is hardy, strong, vigorous, and usually pretty healthy, but unless thorough preventive treatment is given, both foliage and fruit are often injured by apple scab fungus. The form of the tree is wide-spreading, somewhat drooping, rather dense. Twigs medium to long, often somewhat crooked, rather stocky, internodes usually short. Bark olive green with reddish brown, thinly covered with lines of gray scarf skin, pubescent. Leaves rather large, broad, foliage rather dense. Fruit is above medium to large or very large, quite uniform in size and shape. Form roundish, oblate or sometimes inclined to conic, regular or a little inclined to elliptical, somewhat obscurely ribbed, symmetrical or sides slightly unequal. Skin moderately thick, tough, smooth, waxy, grass-green varying to rather yellow.

Originated in Rhode Island, and in the town of Foster, in Rhode Island, is a tree supposed to be nearly 200 years old. (1914.)

Rome Beauty

The Rome Beauty originated in Ohio, by H. N. Gillett of Lawrence county, and was first brought to the notice of the public in the Ohio Fruit Growers' Convention in 1848. It is coming to be widely



Delaware Red.



Red Astrachan.

Matted Photo.



Rhode Island Greening.



Black Ben Davis.

Masted Photo.

distributed over the middle and western states, although Stinson says it is not well adapted to Missouri. It is growing into favor in the Pacific Northwest, as one of the most profitable varieties, being considered an early bearer, a good bearer, and perhaps the best baking apple in the markets. It is better adapted to the middle section of the United States than to the northern or southern sections.

Tree not a very vigorous grower as it appears in the nursery, but in the orchard it attains to greater vigor and good medium size. Form at first upright, but later it is roundish to somewhat spreading, and drooping with rather slender lateral branches.

Fruit medium to very large, usually averaging about medium. In the Pacific Northwest it is much above medium. Form roundish conic or slightly oblong, regular or faintly ribbed, usually symmetrical with sides sometimes unequal.

Skin thick, tough, smooth, yellow or greenish, more or less mottled with bright red, sometimes with a general red color.

See *Red Rome Beauty*.

Flesh white, or nearly white with slight tinge of yellow, firm, moderately fine

grained, rather crisp, juicy, slightly aromatic, agreeable mild subacid, commonly good but not high in quality.

Season from November to April or May.

Red Rome Beauty

The "Red Rome Beauty" was one that I discovered in my orchard a number of years ago. I noticed in one of the rows of Rome Beauties a tree the fruit of which was much redder than on any of the others. This particular tree has the characteristics of a Rome Beauty except in the coloring of the apple. The shape of the tree, the manner of growth, the shape of the twigs and leaves are all of the Rome Beauty. In fact when the fruit is off the trees there is no difference that any one can detect.

The apple is the same in shape and size as the ordinary Rome Beauty but has a solid red color. This coloring makes it a very desirable apple for early market.

The trees in which this tree appeared were purchased from Mr. C. L. Whitney of Walla Walla, Wash., in 1895. Nine years ago I grafted a number of trees from this tree, and after these came into bearing I found that they were the same as of the parent tree. Three years ago

I took scions from these and grafted other trees with the same result. Last spring I grafted from the third generation and while these have not borne, yet I do not fear but that I shall get the same "Red Rome Beauty."

J. HOWARD WRIGHT

North Yakima, Wash., November 26, 1912.



Red Rome Beauty.

Maxted Photo.

Another tree of this same variety, and to all appearances identical, is owned by Mr. Harry Maxted near North Yakima. The original stock seems to have come from the same nursery and about the same time as that of Mr. Wright's, described above.—Ed.

Ross Morris

This apple, which we call the Ross Morris, came from the orchard of Mr. Ross Morris of Zillah, Washington, and seems to be a variation from the Jonathan. It was bought in 1898 with Jonathan stock, from a nursery in Walla Walla, Washington. The tree is inclined to dwarf, being only a little more than half as large as the Spitzenburg and Jonathan of the same age. The top and limbs are very like those of the Jonathan but a little more slender. Bark yellowish; leaves much like those of the Jonathan, but not quite so broad. Bears at about the age of eight years, or two years later than the Jonathan; but when its bearing period begins it bears heavily, and requires thinning.

Fruit medium size, round, oblate, red with specks of yellow and an occasional light colored spot, as if shaded by a leaf. Skin rather tough, flesh tender, juicy, sweet or a very mild subacid. It keeps well in common storage, and has been kept out of cold storage in an ordinary cellar, until May or June. Is a good shipper, good for baking, and good for dessert, for persons who like the sweet varieties.

It is so much like the Jonathan in appearance that if it were not for its keeping qualities and decidedly different flavor, it might be easily mistaken for that variety. Matures from November on.

SPITZENBURG. See *Esopus Spitzenburg*.



Ross Morris.

Seedless Apples

Within the last few years there has been in several places discovered what is called the "seedless apple." In Washington, Oregon, California and Colorado there have been accounts published in the papers of apples without seeds, and without cores. Also word comes from Scotland, Conn., through the Connecticut Experiment station, that a seedless apple has been produced there.

In some parts of the Pacific coast, persons have undertaken the propagation of the seedless apple, claiming for it superior qualities in various ways. Julian A. Dorrance, of Scotland, Conn., claims for



Apple Leaves, Showing Different Types. Those who are familiar with these different characters are able to tell, within certain limits, the variety to which a tree belongs before it comes into bearing. 19, Wealthy. 20, Yellow Newtown. 21, Yellow Transparent. 22, Winter Banana.

—Selected by W. S. McLain.

his seedless apples superior keeping qualities, as compared with apples of the same variety bearing seeds. He says: "The apples which were of the Porter variety, were picked from a tree which produced six bushels. Some of these differed in shape from the others, and in picking out those of different shape, and examining some of them, it was discovered they had no seeds. He says they have the same flavor as the others, but the meat is much more solid; and that while those with seeds are practically all gone, those without seeds are in perfect condition."

At present there is not sufficient information obtainable to recommend the propagation of any variety of seedless apple, except as an experiment. We may be on the way to the discovery of something of considerable value, but it is yet to be proven.

GRANVILLE LOWTHER

Stayman Winesap

Van Deman calls this the best variety of the Winesap class for general cultivation. Taylor remarks that the only particular in which it does not equal its parent is in its color, which is somewhat less brilliant than that of the Winesap, and adds that it appears to be adapted to a wider range of soils and climate.

Historical. This variety was originated from seed of Winesap in 1866 by Dr. J. Stayman of Leavenworth, Kansas, and bore its first fruit in 1875.

Tree moderately vigorous. Form spreading and somewhat open. Twigs below medium to rather long, irregularly crooked, moderately stout, with large terminal buds; internodes medium to long. Bark dark brown or reddish brown with some olive green, heavily coated with scarf skin, pubescent near the tips.

Fruit medium to large, uniform in size and shape. Form roundish, conic to globular, flattened at the base and rounding toward the basin; sides sometimes slightly unequal. Stem medium to short. Skin smooth, rather tough, thick, green becoming yellowish, often nearly covered with rather dull mixed red and rather indistinctly striped with dull carmine. In the

Pacific Northwest in the arid sections, the color is red, sometimes approaching a deep color. Flesh tinged with yellow or slightly greenish, firm, moderately fine grained tender, moderately crisp, juicy, aromatic, sprightly, pleasant to subacid.

In this section it does not rank with the old Winesap as a commercial apple, and in this respect has proved rather disappointing. Season from December to May.

Tompkins King

This apple is commonly called King. Less frequently it is called Tompkins County King, or King of Tompkins County.

The fruit varies in color from striped to a beautiful red with enough contrasting yellow to make it an attractive appearance. It is symmetrical, uniformly large, and excellent in quality, either for dessert, or culinary purposes. It is well adapted for marketing in fancy packages, and is in good demand for the special or general trade. Its season is from late September to early December. It is probably better adapted to the northeastern part of the United States than in any other part but it does fairly well in some other parts. In the Pacific Northwest it does not reach that high degree of perfection that makes it one of the most desirable in New York. While in this section the tree is a very vigorous grower, and the fruit well developed and of good quality, it is not relatively as desirable as some other varieties.

Historical. It is supposed to have originated near Washington, Warren county, New Jersey, and to have been brought from that place to Tompkins county, New York, in 1804, by Jacob Wycoff, who gave it the name of King.

Form of tree spreading, open; lateral branches rather slender and somewhat drooping. Twigs long to above medium, curved or irregularly crooked, moderately stout with thick tips; internodes long to below medium. Bark dark brownish red, mingled with yellowish green. Skin smooth, somewhat roughened with russet dots, fine yellow mottled and washed with orange red, often shading to lively deep

red, splashed and striped with bright carmine. Dots rather numerous, conspicuous, white or russet. Flesh attractive, yellowish, rather coarse, crisp, tender, aromatic, juicy subacid, very good.

Wagener

The Wagener is grown in certain sections of the country, and at its best is an excellent apple. The color is a beautiful red with some contrasting pale yellow; it has a fine texture, high flavor and excellent quality.

Fruit medium to large. Form oblate to roundish oblate, broadly ribbed or irregularly elliptical; sides often unequal. Skin thin, tough, smooth, glossy, bright, pinkish red striped with bright carmine and mottled and streaked with thin whitish scarf skin over a pale yellow clear background. Flesh whitish, slightly tinged with yellow, moderately firm, rather fine-grained, crisp, tender, juicy, subacid, aromatic, sprightly, very good.

Tree dwarfish, at first moderately vigorous, but soon becoming a slow grower; branches short, stout, and filled with spurs. Form, as described in the "Apples of New York," roundish to spreading open. However, as it grows in Washing-

ton, it is an upward grower, and branches shaped more like those of the Bartlett pear. Twigs dark to medium, often somewhat curved, moderately stout, usually quite blunt, internodes medium to short. Bark clear dark reddish brown, mingled with olive green, lightly streaked with scarf skin; pubescent near the tips. It comes into bearing at an early age; but the tree is rather short lived.

Historical. The first historical reference to the Wagener is that given in the report of the New York State Agricultural Society for 1847, in which it was said that it was awarded second premium as a seedling of great merit. In 1848 it was entered again and took first prize. It is said to have originated from seed sown by George Wheeler of Dover, Dutchess county, New York. In 1848 Abraham Wagener propagated it so largely that it was given his name.

Wealthy

The Wealthy is well adapted to northern climates because the tree is very hardy and resistant to cold. It is somewhat dwarfish to medium in size, short, moderately stout, curved branches. Form upright, spreading or roundish, open and somewhat drooping. Bark dark brown,



Wagener.

Matted Photo.

lightly streaked with scarf skin, pubescent.

Fruit bright red, above medium to large, but inclines to be small and to ripen irregularly on old trees. Form roundish conic, slightly flattened at the base, regular, symmetrical. Stem usually short to medium, cavity decidedly acuminate, rather deep. Calyx medium sized, closed or partly open. Skin thin, tough, pale yellow or greenish, blushed and marked with narrow stripes and splashes of red, deepening in highly colored specimens to a brilliant red that is very attractive. In almost all parts of the arid sections where it is grown it takes on a rich color. Flesh is whitish, sometimes stained with red, moderately fine, crisp, tender, very juicy, agreeable subacid, sprightly, somewhat aromatic, good to very good. Season from October to January.

Historical. Originated by Peter M. Gideon, Excelsior, Minnesota, from the seed of the Cherry Crab, which he obtained from Albert Emerson, Bangor, Maine, in 1860. The fruit was first described in the *Western Farmer*, in 1869.

White Pearmain

The White Pearmain is the same as White Winter Pearmain and is a very excellent apple in some sections of the country. It is well adapted to the conditions of the southern sections of the middle states, such as Ohio, Indiana, Illinois, Missouri and Kansas. It is also a good apple in the Pacific Northwest but does not bring the highest prices.

Warder says: "This fruit was brought

to Indiana by some of the early pomologists, in the days of the saddle-bag transportation. In a lot of grafts, two varieties having lost their labels, they were propagated and fruited without name. Being considered Pearmain-shaped, they were called respectively Red and White Pearmains. The former proved to be the Esopus Spitzenburg, the latter has not yet been identified." In 1858 it was catalogued by the American Pomological Society, as White Winter Pearmain. In 1897 it has been listed as White Pearmain, but the old name still clings to it, and is that by which it is generally known.

Tree vigorous, form spreading. Twigs short, stout, blunt at the tips, generally straight. Internodes vary from short to long. Bark reddish brown overlaid with heavy scarf skin, quite pubescent.

Fruit medium to large, mainly uniform in size and shape. Form roundish ovate, or roundish oblong conic, varying to roundish conic, somewhat ribbed, pretty, symmetrical. Calyx medium to large, usually closed; lobes long, acute. Flesh slightly tinged with yellow, firm, fine grained, crisp, tender, juicy, mild subacid, sprightly, very pleasant aromatic, very good for dessert and for culinary purposes.

Season December to March.

Winesap

The Winesap is one of the oldest and one of the most popular apples in America. It is known in all the principal apple growing sections in the United States and Canada. The Winesap has evolved many seedlings which partake more or less of



Belmont Waxen.

Hoer.

King David.

Matted Photo.

the characters of the parent. Among them are the Stayman Winesap, the Paragon, Arkansas and Arkansas Black.

The tree is rather vigorous, though not a rank grower, comes into bearing early and is a remarkably regular cropper. It does best on rather light, rich, deep soils and does not succeed well on heavy clays or in damp locations. The difficulty with the Winesap is its tendency to grow small. However, there are a few sections in the United States where it reaches a good size, and it is one of the best commercial apples. Notably among them are the Piedmont region in Virginia, and the Pacific Northwest. In sections where it tends to grow small this may be obviated somewhat by fertilizing the soil, or by heavily pruning the tree.

Form roundish, spreading, rather straggling and open. Bark very dark reddish brown with thin gray scarf skin, somewhat pubescent. Foliage thin, leaves rather small and narrow.

Fruit rather small but uniform in shape and size. Form roundish conical, nearly truncate at the base. Skin medium in thickness, tough, smooth, glossy, bright deep red. Flesh tinged with yellow,

veins somewhat red, very firm, rather coarse, moderately crisp, very juicy, sprightly subacid, good to very good.

Historical. Nothing definite is known of the origin of the Winesap. Coxe speaks of it as being the most favored cider fruit in New Jersey. From this it has been inferred by some that it originated in that state but this is not proven.

Winter Banana

The Winter Banana has not been very extensively planted, although it is a very beautiful apple in its appearance. The fruit is large, clear, pale yellow with beautiful contrasting pinkish red blush, aromatic, of good dessert quality, but too mild in flavor to excel for culinary uses. The tree is a good grower, comes into bearing young, and bears heavy crops. In ordinary storage, the fruit is good for use from December to the first of April.

It is not highly regarded as a market variety on account of the tender flesh and color which shows bruises very readily. It is so easily bruised and shows its bruises so clearly that in picking, packing and marketing it must be handled with very great care.



Pennsylvania Red Streak.

Marted Photo.

Historical. The Winter Banana originated on the farm of David Flory, near Adamsboro, Cass county, Indiana, about 1876. It was introduced by Greening Brothers, Monroe, Michigan, in 1890. However, it has not been largely planted in that state, and probably is not well adapted. In the Pacific Northwest it is regarded as one of the most beautiful apples grown, but not likely to become a favorite for the markets on account of its susceptibility to bruises.

Yellow Bellflower

The Yellow Bellflower belongs to a group of apples, most of which have fruit predominantly yellow. The fruit of the group is characteristically oblong or roundish oblong and often markedly ovate or conic, with the core large and abaxial, cells wide open and carpels elongated, rather narrow and much concave.

The group is represented by the following varieties: Dickinson, Flory, Kirkland, Mason Orange, Minister, Moyer, Newman, Occident, Ortley, Titus, Pippin, Yellow Bellflower.

The fruit of the Yellow Bellflower is large, but is somewhat variable in size so that there is often a large per cent of the apples, especially when grown where the rainfall is scarce during the growing season, that do not reach marketable

size. At the time of picking it is generally a greenish yellow, but as it ripens it comes to be a light golden yellow. It is rather acid until well ripened when it is pleasant and luscious. It is tender and easily bruised, yet when grown in some sections, if carefully handled, it keeps well, while in others it deteriorates rapidly. In California it is one of the best apples when grown upon the highlands or mountain sides.

It originated in New Jersey, and the first account we have of it is in 1817, but it soon came to be largely propagated in all the eastern and middle states and is now fairly well distributed throughout the United States.

The tree is from medium to large, vigorous, upright, with spreading branches, bark dull brownish red with shades of green, uniformly overlaid with moderately thick scarf skin, more or less pubescent.

Yellow Newtown

The Yellow Newtown is one of the best, if not the best, commercial yellow apples. In pomological literature it is often called Newtown Pippin, Yellow Newtown Pippin and Albemarle Pippin. There is also a Green Newtown, which resembles the Yellow Newtown so closely in all except color that it is difficult if not impossible to distinguish between them in any other



Rome Beauty.



Yellow Newtown.

Matted Photo.

way. As its name indicates, the Green Newtown is not so deep a yellow as the Yellow Newtown, especially at the time of picking, but later it takes on a rather deep yellow. It is impossible with the information we have to tell which was the original. Beach says: "It is now believed that Albemarle Pippin is Yellow Newtown, and Brooke Pippin is identical with Green Newtown." Both varieties differ greatly in size, color and quality in different locations. The Yellow Newtown has been most successful in the Piedmont section, Virginia, in the high lands of California, Rogue River, Oregon, Hood River, Oregon, and Yakima and Wenatchee valleys, Washington. There are doubtless other sections where it can be as successfully grown as in the places named, but in these sections it has been tested and proven commercially very successful.

Tree rather a slow grower. Form spreading or roundish, rather dense. Twigs medium in length and thickness, pubescent near the tips. Bark clear, dark, brownish red, lightly streaked with scarf skin. Fruit medium to very large, pretty uniform in size but rather variable in coloring. This rule, however, does not apply in the Pacific Northwest, where the coloring is more uniform. Form of fruit roundish oblate and more or less angular. Skin rather tough, smooth, yellowish at harvest with a tendency to a pink blush on the sunny side. Season from February to May.

Yellow Transparent

This is one of the best early apples, ripening in July and August, depending on the latitude in which it is grown. It is very good for culinary purposes and acceptable for dessert. It is a good bearer, and the tree a vigorous grower, but on account of its delicate color and tender skin, it is not a good shipper. It is generally believed that this tree, more than most other varieties, is subject to "blight," "fire blight" or "pear blight."

Historical. This variety was imported from Russia by the United States Department of Agriculture in 1870. It first became popular by the attention given it by Dr. T. H. Hoskins, Newport, Vermont, and has been more or less propagated in all the apple growing regions of the United States.

The fruit is medium or above medium, sometimes large, and generally uniform in shape. Form roundish ovate to roundish conic or oblate, conic, slightly ribbed, sides unequal. Stem medium to long, rather thick. Cavity acute or approaching obtuse, medium to deep, rather narrow, somewhat abrupt, furrowed and slightly wrinkled. Skin thin, tender, smooth, waxy, pale greenish yellow, changing to an attractive yellowish white as it approaches the ripening period. Dots moderately numerous, greenish and light colored, often submerged. Calyx tubes conical. Stamens marginal. Core medium to small. Flesh white, moderately firm, fine grained, crisp, tender,



Yellow Transparent.

Roxbury Russet.
Matted Photo.

juicy, subacid with a pleasant but not high flavor.

York Imperial

The York Imperial is an important apple which is grown commercially in the middle Atlantic states and over a belt of country extending from these states westward into Missouri and Kansas. The tree is a thrifty, vigorous grower, and pretty regular annual or biennial bearer. It seems to prefer rather heavy clay soils and seldom does well on soils that are light or in any way thin or leachy. When properly developed the fruit is large, finely colored and of good quality. There are some objections to it on account of the shape of the fruit, which is oblique or lop-sided, and consequently difficult to pare with a machine. Storage men give its season in cellar storage as extending to December, and in cold storage to February. It stands heat fairly well before going into storage, but often scalds badly and when it begins to deteriorate goes down rather quickly. It seems not well adapted to the northern sections of the apple districts of the United States, as it does not color well. However, in the Pacific Northwest, where the sunshine is bright, this would not be true.

Historical. It originated at York, Pennsylvania, about the year 1830. It soon became a leading market variety of Pennsylvania, Maryland and Virginia, and was exhibited at the State Pomological Society of Ohio in 1855.

Tree vigorous or moderately vigorous. Form upright, spreading or roundish, rather dense. Twigs short, above medium, straight or nearly so, stout or moderately stout and tapering at the tips; internodes medium to long; bark dull brownish red.

Fruit rather uniform in size and shape, medium to large, roundish, oblate or truncate, usually with an oblique axis. Flesh yellowish, firm, crisp, somewhat breaking, a little coarse, moderately tender, moderately juicy, subacid to nearly sweet.

TENDENCY TO FEWER VARIETIES

In connection with the subject of varieties to plant, it is well to remember

that for commercial orcharding the tendency is toward the planting of a few well-adapted varieties. G. B. Brackett says:

"Owing to the greatly diversified soil and climatic conditions that exist throughout the territory of the United States, it would not be safe to attempt to give more than general advice on the subject of varieties to plant. Among the very extended list of cultivated varieties of merit there are few, if any, sections where the apple will grow for which varieties may not be found that will give satisfaction if they have a fair trial. But it is a well-known fact that but few of the many varieties can be safely recommended for a special locality. There are certain varieties that have a wider range of adaptability than others. Instances of this character may be found in the Ben Davis, which has a wide range of adaptability, while the success of the Yellow Newtown or Albemarle is confined to a few localities.

"Then, again, a variety may succeed in widely separated regions, while in the intervening sections it may be an entire failure. This fact is well established in the case of the Yellow Newtown, which reaches its highest state of perfection in certain sections of the Pacific coast fruit regions and in the Piedmont sections of Virginia and North Carolina, while in most of the widely diversified intervening territory it is nearly worthless.

Local Conditions

"With these facts before the reader he will readily see how unwise it would be to attempt to offer in this connection other than general advice on the subject. A comparatively safe guide for the planter to follow or to be governed by is to study well his immediate environs and to take counsel of those of his neighbors who have had practical experience in growing varieties on soils and exposures quite similar to his own. In this way he may be able to obtain valuable information in regard to varieties that have been tested and found to succeed in his neighborhood.

Present Demand

"In the pioneer days of fruit culture, especially in the Mississippi valley section of our country, the great aim and ob-

ject of the enterprising planter seem to have been to secure and plant all of the numerous varieties within his reach without considering the question of the adaptability of the variety to the conditions of soil and climate. For a time at least, while the soil was new and diseases and insects were less numerous, his efforts gave fairly satisfactory results. Now, however, conditions have changed and many of the sorts that were once popular and profitable are considered valueless. So that, notwithstanding the fact that the list of desirable varieties is greatly increased, growers find themselves compelled to study more carefully the adaptability of the varieties suited to their special conditions and purposes."

CULTIVATION

Reasons for Cultivation

We cultivate the apple orchard much as we cultivate any other crop and for the following reasons:

It improves the physical condition of the soil.

It tends to drain the soil, which is important if the soil is wet, or is likely to become so.

It breaks up the compact particles of soil and releases new plant food.

It tends to mix more thoroughly the fertilizers that are in the soil with the soil itself.

It conserves the moisture by forming a dust mulch on the top which lessens evaporation.

It kills the weeds that sap the moisture and fertility of the soil.

Deep Plowing

In the beginning it is not possible to break the ground too deeply. Deep plowing is the best in preparation of the land for planting an orchard, and it is the best later if it does not interfere too much with the roots of the trees. By this means the hard substances of the soil are broken up and the land aerated; it enables the soil to absorb more of the water coming from rains and snows; it brings to the surface stores of plant food not generally drawn upon; it turns under the humus in the surface soil, plac-

ing it within easy access of the roots of the trees; it hastens *growth* during the bearing period and increases the size and capacity of the trees.

Illinois Experiment

These principles herewith set forth have been learned by experience and observation through generations of trial. In Illinois, for instance, we discovered that trench plowing was better in case of drouth and better in case of extreme wet weather which we often had in that country. Trench plowing is what in some sections is called "sub-soiling," but it is properly distinguished from subsoiling in that in sub-soiling one team hitched to a plow turns a furrow, another team hitched to another plow called a "sub-soil plow" follows and loosens up the soil in the same furrow, and without throwing it out upon the surface leaves it to be covered by the next furrow.

This method is intended to break up the lower stratum of soil which may have been hardened by years of cultivation of the surface or from other causes. Trench plowing is the same, except that the substratum is turned out upon the surface and on top of the first furrow. At first it was doubted whether this was better in case of extremes of wet or dry weather, but later all doubts were dispelled by comparison of the quantities of crops that grew on soils that had been subsoiled. It was discovered that trench plowing tended to drain the soil in case of excessive rain and to hold the moisture by preventing rapid evaporation in case of drouth.

Kansas Experiment

In Kansas we met new conditions. The question in that state was not so much how to drain the soil of the water that fell upon the surface, but how to conserve the moisture. I made several experiments which determined the value of deep plowing as a check to rapid evaporation. Near Dodge City, Kansas, I had 40 acres of land in what was called the semi-arid belt. A controversy arose among the farmers in regard to the depth of plowing best suited to the growth of corn, wheat, millet and other crops. I

selected a strip of about 10 acres as an experiment, plowing five acres as deeply as possible by the trench method. The other five acres I plowed according to the usual method of turning a furrow about four or five inches deep. I then planted corn, potatoes, pumpkins, melons, sorghum, kaffir corn and millet. We planted across the field, making the rows run the short way so that each kind of product would grow, half of it on the deep plowing and half on the shallow. In every case the deep plowing was better, and in some cases it produced more than twice what the shallow plowing produced. I therefore proved that by proper cultivation it was profitable to grow crops where often the efforts would otherwise end in failure. It was not unusual for travelers passing that field to stop and inquire what made the difference in the apparent size, health and vigor of the same kind of products grown so closely together. Our answer was that we were making experiments like Dr. Franklin, who believed that a certain kind of plaster would greatly improve the land for the production of wheat but had some difficulty in convincing his neighbors. He therefore placed it on the land in the form of large letters which read, "This has been plastered." As the traveler passed by he could see the white plaster and read the letters. When the wheat grew the soil on which the letters had been placed produced greener, more vigorous and taller wheat than the other. As the traveler passed by he could see and read from the field of growing wheat, "This has been plastered."

Another experiment of a similar kind, but with reference to trees, occurred at Jetmore, Kansas. A farmer in that county for some offense had been placed in jail to languish during the summer until the autumn or winter term of court, awaiting trial. Being accustomed to hard labor, the confinement of the jail was very irksome and he obtained permission from the sheriff to cultivate the trees that grew in the courthouse block. When I visited that town I saw that the trees in the community lacked vigor and most of them were dying, but the trees in the

courthouse block were green and vigorous and making rapid growth. When I asked the reason I was told that this man had been given a horse, cultivator and hoe, and that he spent half of every day cultivating the trees, going over the ground once or more each week during the summer and autumn. The soil was as fine as ashes, but little moisture escaped by evaporation; the roots of the trees absorbed the retained moisture and with it the plant food that was contained in the soil.

Campbell System

About the same time the government established a branch experiment station at Dodge City and obtained results similar to those described. The Campbell system of dry farming is simply another name for the system recommended by the government experimenters, and which has been proven by varied experiences to be the system best adapted to semi-arid regions. This system simply means deep plowing, then cultivating, harrowing, rolling, harrowing again, and repeating this process at certain periods during the crop season, and more especially after every shower of rain. By this process, vast wheat fields are now yielding their millions of bushels of grain, homes and orchards and groves are seen by thousands where once was desert, and millions of acres of land which were once nothing but waste are producing wealth.

Good cultivation causes the soil to absorb moisture. This is seen when we compare a well plowed field with the roadway by its side. We pass along the roadway as a heavy rain is falling and we see that the water which falls upon the plowed field is being absorbed by the mellow earth, while the hard surface of the road is absorbing it very slowly, so slowly that the ditches, trenches and wheel tracks are full, carrying it away. That which we see in the road during the rain is true in some degree on the hard surface soil of an uncultivated field, and in a degree also, in a field of shallow plowing.

What Cultivation Does

Cultivation makes plant food available by breaking up the harder chunks, clods

and particles of earth that the roots would not penetrate unless broken up. For instance, a rock contains many constituents necessary to plant growth, but as rock it is not available as food. Pulverize the rock and moisten its particles and the roots will drink in their chemicals. The same is true of clods and of fertilizers. The breaking up, the eroding, the mixing of the harder substances until they are fully pulverized, render them soluble and make it possible for the roots to take their food in solution very much as human beings take food in the form of soup.

Weeds—Weeds also absorb moisture, and because they compete with the trees for something to eat they should be destroyed and the food given to the trees.

Irrigated Sections

In irrigated districts, where abundant water is supplied, the question of moisture is not so important. However, irrigation does not pulverize the soil and does not keep down the weeds. In fact, it cannot be profitably substituted for cultivation however much it may render unnecessary cultivation to conserve moisture. Our motto is, Drainage for wet lands and dust mulch for dry lands.

Deep Plowing for Large Trees

The question of deep plowing for large trees in the orchard has been a mooted question. We have taken both sides of this question.

First, we favored deep plowing, thinking that it would be better to turn under a coating of barnyard manure and throw up the hard sub-soil. We did this, and tore up so many of the little roots of the trees that we believed we had injured the orchard. It seemed to us impossible for the tree to have its root system thus disturbed without injury. However, we had pruned rather heavily that year, and the breaking of the roots did not correspond in amount to the cutting away of the tops. We watched the trees carefully, and for the first year saw nothing to indicate that they had been either helped or injured. The second year they seemed to take on new vigor and the fruit was especially fine.

This was doubtless due in part to the coating of barn yard manure, but we also think that the deep plowing where the soil is deep and the roots can penetrate it easily may be beneficial. By observation in other orchards, we have reached the conclusion that when the surface roots are broken, generally the lower roots will sink more deeply into the sub-soil, and that deep plowing is a kind of root pruning. But often the roots will not get sufficient moisture at the greater depth, or the soil is so hard that they cannot penetrate, and more or less injury is done by deep plowing. The latest demonstrations have proven that a great percentage of the feeding rootlets are near the surface, and that most of them are from one to two feet in depth. The consensus of opinion is therefore shifting in the direction of shallow instead of deep cultivation for bearing orchards. At this writing the question is a debatable one, and the probabilities are that in some cases it is helpful but in others injurious. (See TREE ROOTS)

Cover Crops

What we have said in favor of cultivation is not intended to disparage or to discourage the use of cover crops in orchards. In fact, experience has shown that after an orchard has had clean cultivation until the trees are reaching the bearing period, the very best cultivation they can have, provided there is sufficient water, is the breaking up of the sub-soil by the strong vigorous roots of alfalfa. It is common for these roots to penetrate the soil to a depth of 25 feet, and in some places in a loose porous soil, as proven by the Arizona Experiment Station, they have gone to depth of 50 feet. They are much more vigorous than the roots of fruit trees, and in breaking up the hard sub-stratum, they lead the water to greater depth, and open up a new world of plant food for the roots of the trees. In the arid regions where irrigation is practiced, and where the soil lacks humus, alfalfa, according to the best information available now, is the very best treatment for orchards set to apples and pears.

It has been about as clearly demonstrated that alfalfa and clover are not good for peaches, as that it is good for apples and pears. Just why this is true is not with certainty decided. Some suggest that it is because they furnish the soil with too much nitrogen. Others that it is because of the different rooting habits of peaches, the roots being nearer the surface and tending to grow laterally. Whatever may be the reasons, it seems sure that peaches do not do well in orchards sown to alfalfa.

GRANVILLE LOWTHER

CULTURE VERSUS SOD MULCH

West Virginia View Point

There are strong advocates of both cultivation and mulching as methods of orchard management, and strong arguments may be advanced in favor of each. As a result of personal observation, extending over a period of more than ten years, the writer would favor cultivation upon those lands which are susceptible of culture, without unnecessary expense, and mulching upon all other lands. What that cultivation shall be, and what that mulch shall be will of course be determined by local conditions.

By the advocates of "sod-culture" it is claimed that, by setting free too much nitrogen, cultivation renders the wood spongy and the fruit soft. It is also claimed, and not without apparent reason, that certain varieties, like Alexander and Yellow Transparent, which are subject to blight, exhibit a marked increase of this blight tendency under cultivation. This condition is supported by Mr. George T. Powell, himself an advocate of high culture.

There is no doubt that fruit from trees not under cultivation is of higher color, and usually of firmer texture. That it will always keep better in storage, however, has not been fully proved.*

The general principles involved in the two methods are very simple. In the

* See Bulletin 122, Maine Agricultural Experiment Station, p. 200. 1905.

mulching, the aim is to accumulate all of the vegetable matter possible in the soil, thus not only feeding the plant, but holding the moisture as well. Under cultivation, the organic matter is used as rapidly as possible and more is added in the way of cover crops and green manures.

W. M. MUNSON,
Morgantown, W. Va.

TILLAGE VERSUS SOD MULCH

New York View Point

Early in the history of orcharding in New York it had been the custom during the first six or eight years to grow crops with tillage between the trees, after which the orchard was seeded down to grass and used for pasture or hay. The orchards were in many cases unproductive and, the owners despairing of the method, a reaction set in toward "tillage and cover crops." During the last decade, however, some excellent results in "sod mulch" orchards led to a second reaction to the latter method with a wide discussion of the problems involved.

The New York State Agricultural Experiment Station at Geneva secured in 1904 the use of an apple orchard at South Greece, near Rochester, in order to throw some light upon this question and to demonstrate the comparative value of the two methods under the conditions existing in those places, and to discover, if possible, the reasons for the results that might appear. The experiment was to run for 10 years in order to secure fair average results. Five years have now passed and it may be of interest to note the progress of the work to the present time (1910).

The orchard at South Greece, seven miles west of Rochester, is owned by Mr. W. D. Auchter. It consists of nine and one-half acres of Baldwins set in 1877, the trees standing 40 feet apart each way. The surface soil is a medium heavy clay loam. The subsoil is of heavier loam yet containing enough sand or gravel to make it porous so that the trees do not suffer from lack of under-drainage. The surface is nearly level. This orchard is typical of many of the commercial or-

chards scattered throughout Western New York.

Plan of Experiment—The orchard was divided into two equal divisions, one-half kept in sod—the other half plowed early in the spring, receiving from four to six cultivations during the summer until the last of July or early in August, at which time a cover crop of clover or oats was sown. The grass on the sod half of the orchard was cut once or twice each year as occasion required and was allowed to rot where it fell. The spraying, pruning and fertilizing treatments were same on each plat.

The following is a statement of some of the results obtained with both tree and fruit.

The average annual yield on the sod plat for the five years was 72.9 barrels per acre; for the tilled plat 109.2 barrels—a difference of 36.3 barrels in favor of the tilled plat.

There was a marked difference in size of fruit, requiring an average of 434 apples per barrel for the fruit from sod and 309 apples for the fruit from the tilled trees; the fruit from sod trees averaged 5.01 ounces and the fruit from cultivated trees 7.04 ounces.

The fruit from the sod mulch plat was of better color than that on the tilled plat—it matured from one to three weeks earlier; it was inferior in crispness, in juiciness, in flavor and in quality.

The average gain in diameter of trunk for the trees in sod was 1.1 inches; for the trees under tillage, 2.1 inches.

The average annual growth of twigs of the trees in sod was 3.4 inches; of the tilled trees, 6.7 inches. The total weight of 240 twigs from sod trees was 7.2 pounds; from trees under tillage, 21.3 pounds.

The leaves on the sod trees were yellowish—on the tilled trees a dark, rich green.

Financial Statement

The average annual cost per acre, not including harvesting, was \$17.92 for sod, and \$24.47 for tillage—a difference of \$6.55 in favor of sod.

The average net income per acre from sod was \$71.52, and from tillage, \$110.43, thus giving an increase due to tillage of 54 per cent.

Causes of Difference

Moisture—The soil to the depth of one foot showed as the average of 120 moisture determinations 156.24 tons water for sod; 235.98 tons water for tillage—an increase of nearly 80 tons in favor of tillage.

Temperature—At a depth of 12 inches the average temperature for sod was 65 degrees; for tillage, 67 degrees—difference of two degrees in favor of the soil under cultivation.

Humus—The amount of humus in the soil to a depth of six inches was 19.98 tons per acre for the sod plat and 21.78 tons for the tillage—an increase of 1.8 tons in the soil under cultivation.

The facts presented include the essential features of what happened in an apple orchard under a tillage system and under a system of sod mulch. The soil, the trees and the fruit have each in turn told their story, and the evidence is before you. Yet it must be kept in mind that the results do not prove that tillage under all conditions is the only proper method of procedure. Every orchard has its special problems and every apple grower has a problem of his own. Any method to succeed must be adapted to local conditions.

The following table will show the relative values of the two methods of sod and clean cultivation. It will be seen that in all but two instances in each case the average yield and average income is greater in the case of "tilled" than of "sod" orchards where the method of culture has extended over the same number of years.

Average Yield in Bushels and Average Income Per Acre of Sod and Tilled Orchards

METHOD OF TREATMENT	1902			
	Number orchards	Number acres	Average yield	Average income
Tilled ten years or more.....	57	645	186	\$134
Tilled five years or more.....	22	185	139	88
Tilled at least three years.....	10	88	165	104
Sod at least three years.....	8	93	157	58
Sod five years or more.....	4	44	145	83
Sod ten years or more.....	14	144	181	105
	1903			
Tilled ten years or more.....	100	1,040	408	\$148
Tilled five years or more.....	40	405	326	117
Tilled at least three years.....	27	368	214	141
Sod at least three years.....	18	353	278	82
Sod five years or more.....	18	292	280	127
Sod ten years or more.....	31	281	264	103
	1904			
Tilled ten years or more.....	117	1,203	282	\$126
Tilled five years or more.....	55	573	224	125
Tilled at least three years.....	44	239	230	131
Sod at least three years.....	53	767	174	87
Sod five years or more.....	20	566	171	83
Sod ten years or more.....	38	338	160	84
	1905			
Tilled ten years or more.....	28	406	258	\$71
Tilled five years or more.....	20	179	312	91
Tilled at least three years.....	18	182	300	49
Sod at least three years.....	48	577	271	53
Sod five years or more.....	35	450	218	37
Sod ten years or more.....	13	146	192	35
	1906			
Tilled ten years or more.....	34	342	261	\$121
Tilled five years or more.....	22	309	270	80
Tilled at least three years.....	16	240	285	60
Sod at least three years.....	38	434	165	57
Sod five years or more.....	37	338	170	51
Sod ten years or more.....	29	332	165	48

The results for Orleans county (New York Bul. No. 229) furnish an interesting comparison (four of the calendar years are the same in the two cases):

Average Yield in Bushels and Income Per Acre of Tilled and Sod Orchards
All Orchards Five-year Average Per Acre

Method of Treatment	Bushels	Income
Tilled ten years or more.....	327	\$182
Tilled five years or more.....	274	138
Tilled over half of preceding five years.....	225	113
Sod over half of preceding five years.....	222	107
Sod five years or more.....	204	108
Sod ten years or more.....	176	87

**Average Yield in Bushels and Income Per Acre of Tilled and Sod Orchards
Orchards All Well Cared For Five-year Average Per Acre**

Method of Treatment	Bushels	Income
Tilled ten years or more.....	337	\$189
Tilled five years or more.....	296	148
Tilled over half of preceding five years.....	234	121
Sod over half of preceding five years.....	242	118
Sod five years or more.....	258	134
Sod ten years or more.....	232	117

Cultivation from the Oregon View Point

We must study this important subject from the point of view of soil, season, age of tree, general climatic conditions, etc. The tools that are used also differ according to conditions. Plow, corrugated roller, float, disc harrow, Kimball weeders, and many other tools all have their places. Our particular object in the spring preparation is to form a reservoir for moisture, and make plant food available so as to maintain a large root-feeding system in order that we may develop strong trees, with vigorous wood and abundance of good sized fruit. With most of our clay soils annual spring plowing will be necessary; with the heavier soils harrowing should follow close on the plowing, as the heavy soils tend to become packed and cloddy. They will need discing and pulverizing and should be put into as good condition as possible. The sticky soils upon which many of the orchards are planted are exceptionally hard to handle. If they are plowed in the fall the soil runs together during the winter and they need replowing in the spring. These soils will have to be watched closely to catch them at just the right time. If an attempt is made to plow while they are too wet, they are so sticky as to be almost impossible to handle. If you attempt to plow them when they are a little dry, they plow up in large lumps and it is almost impossible to do anything with them. Occasionally these soils have been simply disced and thoroughly harrowed in place of plowing.

The free soils and the sandy and silt loams work up very nicely. On the lighter of these soils, and especially with light rainfall, the problem is not so much in the spring to loosen these soils as it is to compact them. They are often rolled

and floated, a drag is used, and when this is done, light shallow harrowing should always follow. Our main object in the spring is then to get the ground into as good conditions for growth as possible. After the rains have ceased great care must be taken to maintain as much of the moisture as possible under the soil conditions. This will mean frequent cultivations during the growing season. One of the best tools to use in such cases is the Kimball weeder; this stirs the soil freely, will pulverize the top soil, and prevents drying or packing. It forms a dust mulch which aids in retaining the moisture in the soil.

The number of times one will cultivate during the summer will vary with the



Fig. 1. Corrugated Roller. One of Best Tools to Use on Clay Loams.

soil, type of fruit, season, and the age of the trees. With young trees it is well to practice deep, thorough preparation in the spring so as to encourage the roots to strike deeply. It is not only a problem of holding the moisture but one of forming deep rooted trees. As soon as sufficient growth has been obtained the summer cultivation should cease; this, in some regions, may be as early as July, while in some locations it will be about the first of August, but rarely later than the middle of August. The aim should be to throw the young trees into dormancy so that they will not be injured

by premature fall frosts or suffer needlessly from cold winter weather.

Bearing apple trees, on the other hand, will need cultivation in most cases up to the time the fruit is picked, since the trees draw very heavily upon the soil as the fruit is maturing. The time for ceasing cultivation with bearing trees will be determined by the general condition of the tree and fruit. Cultivation influences the color and size and often the form of the fruit, the amount of juice, and has a marked influence on the percentage of drop of the fruit.

C. I. LEWIS

Cultivation from a Washington View Point

Sod Mulch—The grass, clover, weed or alfalfa sod mulch system is a relic of primitive horticulture handed down to us like many other relics, to be taken as it is without investigation.

It is an outgrowth of neglect rather than a development of thought, and comes through such reasoning as this: If Oregon fir and Washington pine have grown to such size on these lands without culture, why shouldn't fruit trees do the same? The difference is that nature takes hundreds of years and millions of trees to produce a few big trees, while man takes a few years and a handful of small switches to develop an orchard. We cannot afford to pattern after nature in this matter, but must assist her by conserving moisture, making plant food available and removing the offenders, whether they be weeds or other trees.

The grass mulch system has merits for certain conditions, and while it is occasionally good, is a much abused practice. This abuse in our state shows most strongly on the west side of the Cascades, but it is not wholly lacking on the east. Under various conditions the grass mulch system takes on varied modifications.

Some growers permit weeds and grass to grow at will in the orchard all summer long, only to be mashed down in spring with harrow, light disc and clod masher. The only remarkable feature about these orchards is that some of them are giving fair returns. The probable

reason for the returns is that available plant food and moisture are only secondary considerations in these soils. On other soils the method would be an absolute failure.

Another group of growers permit this mulch to grow until mid-summer, when it is mowed down and placed around the trees to act as a mulch, in the true sense, to conserve moisture, ameliorate the soil and add plant food. The grass mulch system as practiced in this manner on rich, deep, moist soil will prove a success in orchard work, provided the trees are fairly well established before the system is put into operation. Remember again, however, that the moisture problem is taken care of by plenty of rain or frequent irrigation.

A third group of growers cut the mulch and use it for hay or, worse still, pasture the orchard without practicing fertilizer returns. A friend recently sold from one acre of ground \$1,200 worth of apples and four tons of alfalfa hay. In addition he pastured a cow and 50 chickens for three months on the same acre.

Clover Versus Alfalfa Mulch

Considerable discussion has arisen lately relative to the comparative merits and demerits of the two plants, alfalfa and clover, which are most commonly used as grass mulch plants in the West. Each has a strong following amongst our best fruitgrowers, and consequently must have merits of note under favorable conditions.

Those championing clover attribute the following advantages to its growth:

1. Being a comparatively shallow rooted plant, its roots do not feed in the same plane as the roots of bearing trees.
2. It adds more fiber and plant food to the first 18 inches of the soil.
3. It is an easy plant, as compared with alfalfa, to destroy when the time comes to remove the mulch.

Those championing the use of alfalfa contend that it is best because it has the following characteristics:

1. Being a naturally deep-rooted plant it goes below the apple root plane.
2. While it adds a small amount of fiber, its roots work deep into the soil

and thereby extend the feeding area, especially in hard, impenetrable soil.

3. It is a greater tonnage producer under irrigation than the clover.

My own experiences, while confined to a few fields, have been very much in favor of clover so far as removing the mulch and tree growth was concerned, but favorable to alfalfa from the standpoint of tonnage and subdividing and preparing the soil for orchard purposes. I would not seed alfalfa, or clover for that matter, if I seeded at all, closer than four feet from the young trees and then preserve thorough tillage between the alfalfa and the trees. As the trees grow older I should extend the area of cultivation from one to two feet each year, until the whole was receiving clean tillage.

Mulch Lessons From the Season of 1910—Between April 15th and September 15th we had less than one-half an inch of rainfall in Eastern Washington. The weather otherwise, while dry, was not seriously hot, and there were very few strong winds. In the grass mulch experiments we had a great number of the more common varieties of apples. But inasmuch as the Ben Davis is probably better known than any other variety I desire to use it as an illustration. Kindly remember that the soil was uniform and that no irrigation was used.

Plot 1—Old alfalfa plot, 14-year-old trees, fruit one inch in diameter, poorly colored and badly wilted at harvesting time.

Plot 2—Ben Davis variety, but in grass and weed plot; fruit one and one-half inches in diameter, of fair color, but poorly developed; not wilted.

Plot 3—Ben Davis variety, old clover field, trees 14 to 15 years of age, fruits two inches in diameter, well colored, fairly good texture and fair crop.

Plot 4—Ben Davis, 11-year-old trees, given first-class care, clean tillage; fruit three and one-half tier, well colored and good texture. As good a crop as one could desire.

While this little experiment proves much for Eastern Washington, it does not settle the problem for other parts of the

Northwest; yet it does show that where summer moisture is the main factor, we must practice, almost if not entirely, nothing less than clean culture.

After visiting hundreds of orchards last year in Western Washington during the dry season I am convinced that our problems of fruit culture are identical so far as cultivation is concerned; yet there are conditions under which it is advisable to use a grass mulch of some sort or other, and I would enumerate as possible conditions the following:

1. Where the soil is so rich as to cause the trees to produce wood at the expense of the fruit. Pears, cherries.
2. Where the soil is otherwise too wet.
3. In loose, shifting soils that must be held down to prevent blowing
4. On rocky soils that cannot be cultivated.
5. And finally when the owner is too lazy to cultivate and wants a feasible reason for not doing so.

Absolutely Clean Tillage—This is the direct reaction of no tillage, and comes as all reforms do at the swing of the pendulum to the opposite pole. It is very valuable in certain soils where everything is sacrificed for moisture, but needs careful guarding, as it is more liable to injure the soil than any other method of tillage.

The constant working of the soil and never permitting anything to grow upon it, while valuable for the conservation of moisture, materially fines it, thereby making it wash and gully on sloping land, and exposes a bare surface to the hot summer sun. This destroys the humus, causing the soil to cement and puddle much more readily than it normally should.

The loss of the organic content of soil in four distinct ways, i. e.:

1. Destroys granulation or friability.
2. Lessens water holding capacity.
3. Lowers the temperature in spring, and raises it in the summer.
4. Makes it impossible for the air to permeate the soil, thereby hinders nitrification and prevents the escape of carbon dioxide.

Treatment of this kind injures the soil both chemically and physically and can never be classed as practical agriculture.

The evil effect upon orchards planted on shallow soil and treated in this manner is still more perceptible to the trained eye than upon most other crops. We have learned that, by repeatedly cutting off the surface roots of young bearing trees, as is done by the cultivator on soil that is underlaid with hardpan, we produce a yellow starved growth commonly known as winter dessication or fruit tree rosette.

Clean, Early Tillage, with Cover Crops Later—Clean, early tillage, with cover crops later is the type of tillage that we hold out as the practical, progressive tillage. It has all advantages of the clean culture and the grass mulch systems and none of the undesirable features. It conserves the early spring moisture at a season when it is plentiful, prepares and makes available the plant food when the tree most needs it, causes early development of leaf and fruit buds, thereby hardening the tree for winter, and brings the fruit to a good size early in the season in order that it may have a longer time to color and put on the finish. Many of our orchardists do not start culture early enough in the spring, thereby causing a check in the growth of the fruit or twigs when there should be no check. The growing period of most bearing trees is decidedly short as compared with annual plants, and recognition of this fact should be taken into consideration in the working out of our culture scheme.

The thorough tillage of the early spring and summer months should cease as soon as the fruit has attained sufficient size to insure good, marketable specimens by fall. The exact time cannot be stated, but it varies from the first of August to the first of September. At this time some form of a cover crop should be sown at least three years out of five. The nature of this crop will be governed entirely by the condition of the trees. On soil where trees are vigorous and have dark green foliage a non-nitrogen gathering crop, such as fall rye or wheat, may be used, while on soil where the trees are less vigorous and the foliage more or

less yellow, a nitrogen-storing crop, such as Canada peas, vetch or clover, should be used.

Too much emphasis cannot be laid upon the use of cover crops in our orchards. They will do more toward keeping the orchard up to a high standard than any other single thing that we can use. I consider the use of cover crops in orchards the highest type of orchard tillage for the Pacific Northwest. This is good agriculture, and will never wear out a soil, and when those growers who practice it are through using their land the soil will be better physically, chemically, and in every way than it was when they started, even though they have taken a big crop off every year.

The practical questions of when and how to till can best be solved upon each farm. However, the same general scheme can profitably be carried out in all districts.

Just as soon as the surface of the soil is dry enough to work without slicking or sticking, the disc or cut-away harrow should be run over the surface to prevent crusting and heavy loss of moisture. This can be followed by deeper discing or plowing, as the case may be, but under no circumstances should the surface be permitted to crust and bake.

Where no cover crop is used, fall plowing may be practiced to advantage, providing the plowing is shallow close to the trees and deep between them, and the soil is left rough to winter-catch and hold as much snow and rain as possible. It will require a minimum amount of labor in spring to put this soil in first-class condition and keep it that way during the year.

The time to plow that part of the orchard seeded to cover crop must be governed almost entirely by the amount of moisture obtainable after the first of May of each year. If there is an abundance to be depended upon, permit the crop to grow as tall as possible without becoming woody, and then turn it under. If there is danger, as there is in all non-irrigated sections, of a shortage, leave as late as consistent with safety and then plow. In either case, the plowing must

be followed by thoroughly working down the surface with disc or similar tool to chop up the crop and pack the soil down to preserve the moisture. Continue the surface tillage from now on until August, and seed again to cover crop if necessary.

The depth at which the surface working tool should run has been carefully tested out both in the laboratory and in the orchard. As a result of these tests we find that from three and a half to four inches of dust mulch is as effective to conserve moisture as 10 or 12 inches.

W. S. THORNER

From a Connecticut View Point

Where Rainfall Is Light—Under the system of clean culture, cultivation commences as soon as the soil may be worked in the spring and continues till about the middle of August. It is recommended especially for sections where the rainfall is light during the growing season. By maintaining a loose dust mulch on the surface the system is very effective in conserving moisture. On the other hand the continuous cultivation tends to deplete the supply of plant food and humus, or decaying vegetable matter. To maintain the fertility of the soil under this system requires liberal applications of stable manure or some substitute. This system, as practiced by some growers, is very similar to tillage with cover crops, and gives fairly good results. These growers cease cultivating about the middle of July or the first of August and allow the weeds to grow up and cover the ground. The weeds here assume the function of a cover crop. Clean culture alone not recommended. The clean culture system, pure and simple, is not recommended for Connecticut.

Time—The early spring plowing should be followed by repeated cultivations. The aim should be to keep a deep, loose soil-mulch on the surface. The most successful apple growers harrow their orchards every eight or ten days during this period, and oftener, if rains occur in the interim. This treatment liberates plant food, saves moisture, and keeps the weeds down. Any tool that will keep the surface loose is

suitable for this purpose. About July 15th cultivation should cease and the ground be sown to some good cover crop, to be plowed under in the following spring.

A good cover crop should make sufficient growth to protect the ground during the winter and spring and to supply abundant vegetable matter, which, when turned under, will improve the physical condition of the soil and will contribute plant food. The clovers and winter vetches are very suitable for this purpose. These crops are nitrogen gatherers and if a large growth is produced and turned under each year, there should be no need for the application of nitrogenous fertilizers. On the contrary, by repeated cover cropping it is possible, especially in later years, to produce too much wood growth. In which case, instead of plowing under the cover crop, it may be mowed and left on the ground. The object should be to produce a normal and uninterrupted annual growth. Trees that grow too fast are more likely to be injured by severe winters, to have a weak root system, and to form a structure that is not sufficiently strong to bear the weight of large crops of fruit. Most fruit growers, however, are more likely to err in the other direction and allow their trees to become stunted, from which condition they may never recover.

Grass Mulch on Hillsides

On rugged hillsides where there would be danger of washing, the necessity for retaining a sod cover is undisputed. In view of the difficulty of conducting the spraying and harvesting operations on steep hillsides, it is very doubtful whether such land should ever be chosen for orchard purposes. It is probable that a combination of the mulch and tillage systems will be found most useful for New England conditions. The important thing to remember at this time is that, regardless of what system the grower intends to follow, the preparation of the land is essentially the same. On steep hillsides, however, where cultivation is not feasible, the trees may be set in the sod and small circles cultivated around

them with a grubbing hoe. Even in such cases it would be better to break up the sod over the whole area and immediately reseed the land to clover.

Sod Culture for New England

This system in its most ruinous form is the one commonly practiced in New England, and is largely responsible for the unproductive condition of the ordinary farmer's orchard. The apple specialists, as a rule, favor the tillage system, yet there are many commercial growers who hold to some form of sod culture. The special advantage of sod culture is the possibility of producing fruit of better color, but this is probably offset by the possibility of increasing the yield by means of tillage. It is remarkable that fruit from sod orchards has carried off many of the premiums at recent fruit exhibitions in the East. This is especially true at fall fairs that are held too early for winter varieties grown under cultivation. The main purpose of growing apples, however, is not to win premiums and the man who tills his orchard must get his reward in higher profits. The questions for the grower to settle are, which system is best suited to his conditions—his location, his soil, his markets, and his other interests—and which will give him the best return for the capital invested.

There are probably many orchards in New England situated upon washy slopes where some form of sod culture is the only feasible method. It is probable, also, that many more of the rugged and washy hillsides will eventually be planted to apples. This need not concern us now, however, for there are thousands of acres of ideal orchard land available in every state of New England, and so long as this condition prevails, it would seem advisable to select for orcharding land upon which the regular operations may be most conveniently and expeditiously performed. There is often more or less washing, however, on some of the gentle slopes, especially where the soil is of an impervious nature. Serious trouble from this cause usually may be prevented by cover cropping or by leaving strips of sod along

or between the rows of trees and at right angles to the slope.

C. D. JARVIS,
Storrs, Conn.

TOOLS FOR ORCHARD CULTIVATION

Steel Plow—One of the first tools which the orchardist needs is the ordinary steel turning plow. This is needed especially in breaking up the hard soil at a greater depth than any other plow will break it; it is needed in turning under a coating of manure. If cover crops are grown it is needed in turning them under, and for cutting roots there is no other implement used in the orchard with which the work can be done so well.

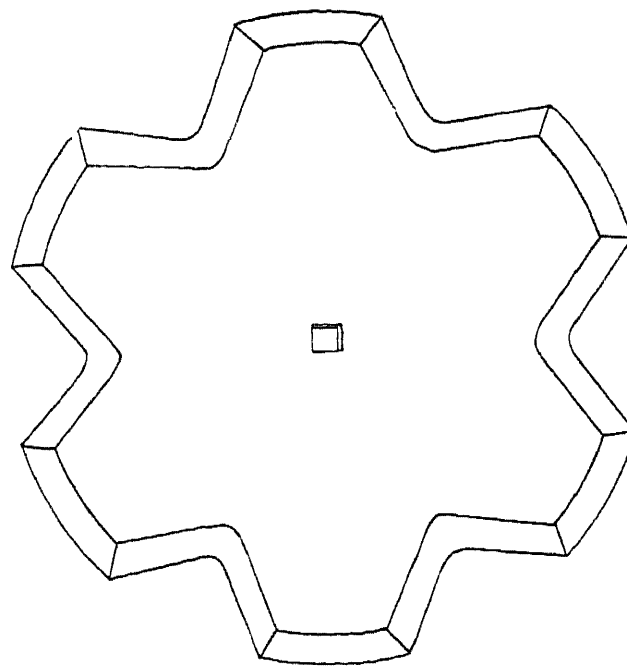

Fig. 1. A Single Disc of the Spade or Cut-away Type.

Disc—Another implement is the disc, which does not turn the soil, but cuts it, loosens and stirs it. There are two kinds of discs in use—one of these, which is called the spade or cut-away disc, is cut into several sections and acts on the soil much after the manner of the hand spade. This implement is considered better on hard soils than the other, which is called the concave disc and cuts away the soil as it rolls over the ground instead of spading it. This is perhaps better on light, loose soils where there are no obstructions, but it is not good on rocky land, or on land where there is brush, weeds, pruning, or such like things on the surface, or on lands that are hard and compact. These discs are now so



Fig. 2. Discers at Work in Young Orchard.

arranged that they may be made to project at a considerable distance under the trees. This enables the orchardist, even where there are overhanging branches reaching nearly to the ground, to cultivate all the soil.

Tools for Low-headed Trees—We advocate low heading. We do it with the knowledge that it is more difficult to cultivate in an orchard of this kind than where the head of the tree is three or four feet from the ground, but we know furthermore that low heading is better

for the tree and makes it easier to pick the fruit, prune and spray, also that the fruit bruises less in falling, and we advocate it notwithstanding the difficulties in cultivation, knowing that machinery can be so built and arranged as to make cultivation practicable.

GRANVILLE LOWTHER

COVER CROPS

There has been a great deal of discussion on the question of growing cover crops in orchards. I confess that for the sake of neatness, and to meet our ideal of beauty in the orchard, I like clean cultivation. The main question, however, is, "Does it produce better fruit, and does it in general improve the soil, thereby bringing better results, than does the use of some kind of cover crop?" For cover crop we generally use some leguminous plant. In some states blue grass, or what is called orchard grass, is used as a cover crop. Sometimes buckwheat or timothy is

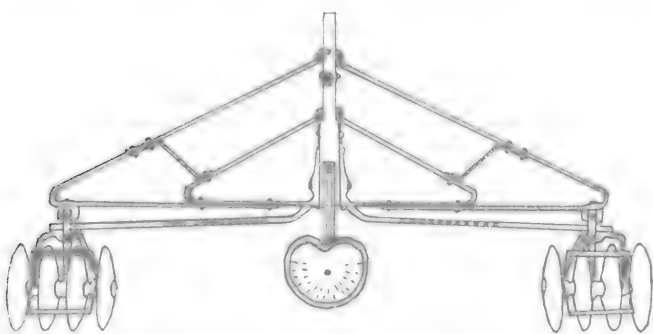

Fig. 3. Extension Disc, Convenient for Cultivating Under Low Trees.

used, but these will not be considered in our discussion, because I do not favor the growing of any crop in the orchard that competes with the trees for moisture and plant food, unless in so doing they put more into the orchard than they take out. The leguminous plants are preferred because they gather nitrogen from the air and deposit it in the soil. The rotting of the top adds humus, and the decaying of the roots improves the soil.

Needs of Soil Considered

The kind of crops that should be grown depends largely on the character of the soil. For instance, a sandy soil that has little or no humus would be greatly improved by the growing of some crops that would add plant food. We have seen sandy soils on which nothing would grow but sand burrs. After these had rotted for a few years and been mixed with the surface soil the character of the soil was changed and then grass and vegetables could be grown. Any of these soils, in the sandy or volcanic ash regions, in an arid or semi-arid climate, will be greatly improved by a mixture of vegetable matter. Other soils are rich in humus and could scarcely be improved by the addition of more, therefore leguminous crops are not needed for the humus which they will deposit in this kind of soil; yet the soil might be improved by the nitrogen which they would deposit, for generally where there is a large amount of humus there has been a large amount of rainfall which has washed out of the soil many of the substances that are necessary for the production of the best fruits.

Why Cover Crops Are Grown

Perhaps it is well to consider the reasons why cover crops are grown and then each one may decide for himself what crop is best adapted to his circumstances:

First: They are grown to check the growth of the trees in the late summer and autumn so that they will mature their wood sufficiently to endure the cold freezing of the winter without being winter-killed.

Second: They are grown to keep the soil from washing or leaching away by the autumn, winter and spring rains.

This is especially important where there is much rain during the winter season, and where the land is uneven or hilly.

Third: They are grown to add humus to the soil, and this, as we have already shown, is very important for soils of a certain character.

Fourth: They are grown to add nitrogen to the soil. A chemical analysis of soils made by the experiment station will show what any particular soil needs.

Fifth: They are grown to break up the hard subsoil so that the roots of the trees may have a larger extension from which to draw plant food.

Sixth: They are grown to aerate the soil, lead the water down to a greater depth and thus make a larger amount of plant food available.

Seventh: It is now claimed that these leguminous crops, especially alfalfas and clovers, are the best curatives for what is called apple rosette, a disease that is attacking the trees in some sections of the country (See *Rosette*.)

Much, therefore, depends on the character of the soil and other conditions as to what should be grown, and much depends on the intelligence and good judgment of the grower as to the degree of success that may be reached by the growing of such crops. For instance, if there is a hard substratum that needs to be broken up in order that the roots of the trees may penetrate more deeply, alfalfa is doubtless the very best leguminous crop, because it has the largest, the most vigorous root system of any of the leguminous plants, penetrating sometimes to a depth of 20 feet below the surface. In loose, deep, gravelly or sandy soils the breaking up is not necessary; and something with a smaller root system would do just as well as alfalfa and perhaps have a larger top system and therefore furnish more humus. Where humus is needed and not the breaking up of the subsoil, clover or vetch would be better than alfalfa.

Removing the Crop

The question is often asked, "Is it permissible to cut the hay or pasture the orchard, if cover crops are grown?" I

see no possible objection to this, provided an equivalent in the form of barnyard manure or some other kind of fertilizer is placed on the land. In the growing of cover crops the trees get the benefit of the root system of the cover crop, no matter whether the top is fed to stock or allowed to rot on the ground. It may just as well be fed to stock as allowed to decay for the purpose of adding humus to the soil, provided barnyard manure is used to add the same amount of humus that the top system would have added, and there is this advantage, that an acre of alfalfa or clover in an orchard should yield something like three or four tons per annum worth from \$5 to \$10 per ton, while its equivalent in manure can be placed on the soil for about \$1 per ton.

Therefore, a considerable difference in profit would grow out of the use of the alfalfa or clover, while during the winter season when not much else could be done in the orchard the barnyard manure could be hauled and put on the land.

What Not to Grow

Among the crops which should not be grown in orchards are timothy, corn,

wheat and oats. I have watched with considerable interest the effects of certain crops upon the growing trees. In one orchard I noted that for four successive years wheat had been grown between the rows, and at the age of four years these trees were not as large as trees three years old across the road and growing under similar conditions, but without wheat. I have noted similar results with corn. Corn and wheat do not take from the soil more of the substances needed by the trees than do vegetable crops, but the latter require more cultivation and are usually rotated.

The following table shows the amount of nitrogen, phosphoric acid and potash said to be removed from the soil by the various crops in one year. It must be remembered that these are three of the elements which the apple tree very much needs, and that the reason why alfalfa, clover, vetch, beans, peas and other leguminous plants are said to be good for the soil is largely because they gather nitrogen from the air in excess of what they use from the soil.

GRANVILLE LOWTHER

Table Showing Amount of Nitrogen, Phosphoric Acid and Potash Removed from the Soil by Certain Crops

Name of Crop	Phosphoric		
	Nitrogen	Acid	Potash
Barley	78	35	62
Buckwheat	63	40	17
Cabbage (white)	213	125	514
Cauliflower	202	76	265
Cattle turnips	187	74	426
Carrots	166	65	190
Clover, green (<i>trifolium pratense</i>)	171	46	154
Clover (<i>trifolium pratense</i>)	37	18	29
Clover, scarlet (<i>trifolium incarnatum</i>)	95	17	57
Clover (<i>trifolium repens</i>)	89	29	58
Cow pea	254	64	169
Corn	146	69	174
Corn fodder (green)	122	66	236
Cotton	110	32	35
Cucumbers	142	94	193
Espalsette	239	36	103
Hops	200	54	127
Hemp	34	54
Lettuce	41	17	72
Lucern (alfalfa)	289	65	181
Lupine, green (for fodder)	219	46	63
Lupine, yellow (<i>lupinus luteus</i>)	80	37	155
Meadow hay	166	53	201
Oats	89	35	96
Onions	96	49	96

Peas (<i>pisum sativum</i>)	153	39	69
Poppy	87	30	87
Potatoes	119	55	192
Rape	154	79	124
Rice	39	24	45
Rye	87	44	76
Seradella	128	57	196
Sojy bean	297	62	87
Sugar cane	518	37	107
Sorghum (<i>sorghum saccharatum</i>)	446	90	561
Sugar beet (beet-root)	95	44	200
Tobacco	127	32	148
Vetch (<i>visia sativa</i>)	149	35	113
Wheat	111	45	58

Cover Crops as Adapted to Missouri Soils

Cover crops are highly essential to the present success of the orchard, but especially to its future success—the lack of it may explain failure.

The more we learn of cover crops the more we appreciate their importance. We have had more or less experience in our plants in Missouri and other states. We have observed the cover crops used in the peach orchards of Georgia and other southern states, of the Lake Shore country of New York, of Michigan, Ohio, Maryland, Delaware, etc., and throughout our own state and particularly the cover crops—and too often the lack of them—in the West and Northwest. We often hear the orchardists explain that we don't get the crops of the old times when this was a virgin country. To repeat such crops one essential is to put the soil in as near the fertile condition it was following the removal of the forests. The mineral elements of the soil remain but the humus has been "burned out." Too many orchards are starving, actually starving—and especially is this true of our Ozark regions.

We have heard the advocacy of weeds as a cover crop. Perchance weeds may be better than nothing, but is that good, up-to-date teaching?

The average soil on chemical analysis shows a fair to a large amount of potash, phosphate and other necessary elements. It is not a question of buying a carload of fertilizer and wondering if it will pay. Commercial fertilizer may pay and often does; and it is sometimes necessary when the soil has been worn out but where

soil contains the necessary minerals, and the air the necessary nitrogen, the question should be only one of making use of what you already have, by putting it into an available form, and not of buying a few tons of fertilizer. The nitrogen will be supplied from the atmosphere by the leguminous crops. The organic matter which is also added by these leguminous crops tends to make the mineral of the soil more available, and with proper management most soils will furnish all the necessary potash, etc. A little green manure should be added every year, which will increase the nitrogen. This is the cheapest method as it can be done by means of cover and catch crops at the end of the growing season when other crops have been removed.

Where any cover crop or manure is turned under, it forms humus, which makes the soil darker, and by test it has been shown that a dark soil is some degrees warmer than the same soil when lighter in color, when under the same conditions.

Humus in the soil makes it act like a sponge. It makes the soil more porous and able to hold more water and retain it longer. It makes a stiff clay soil of lighter tilth by separating and loosening the soil particles rendering cultivation easier.

There are a number of bacteria working in the soil. They must all have food, and the beneficial ones are dependent, more or less, on humus and the decaying organic matter from which it is formed. When these bacteria work, or "digest" the humus, they set free carbon dioxide. The carbon dioxide is a gas which is

taken up by the soil water. This solution is then able to dissolve many insoluble minerals from the soil which are necessary as plant food. Such substances as rock phosphate and limestone, which are practically insoluble in pure water, are made soluble and available as plant food by the action of this carbon dioxide in water.

Humus is partially decomposed vegetable matter. When the vegetable matter forms humus, or the humus breaks down to form still simpler compounds, heat is liberated. Whether a pile of leaves is burned or allowed to rot, the same amount of heat is given off in either case. This means that the decaying organic matter in the soil makes it warmer and drier in the spring. Thus growth will start earlier and be faster throughout the entire season.

Bacteria working in the soil, especially during warm weather, are continually setting free food in the form of nitrates, and other minerals are also changing to soluble form. The nitrates, unless used immediately, are liable to be lost by leaching away in the drainage water. There are some minerals also more or less soluble that may be lost by washing away in drainage water. However, their loss is not so great as that of nitrogen. To avoid this, a crop is necessary during the whole growing season. At the first of the season, the orchard while growing can handle and use all of this available plant food. Later on, when the orchard growth is less active, it is necessary to have a cover crop of some sort to use this food and get it in a form that can be carried over until the next season without loss. Such crops as clover are especially good. They not only use all the available nitrogen in the soil, but they add more from the air, and in the spring they decay readily, liberating their contents to be used by the trees.

The ideal cultivation for orchards in the Central West is, we believe, intensive, clean culture from early spring to June, then seed to cow peas—either drilling and cultivating or broad casting. In this connection, the Western Fruit Grower says:

“Regarding cover crops for the Middle West, will say that we agree with you that nothing is better than cow peas, except that lots of orchards are on hills so steep that it will not do to give them cultivation in early spring, during the rainy season. We think that very soon we shall have to adopt a plan of cultivating two rows and leaving the next two rows in clover and alternating this treatment.”

There are numerous and various varieties of cow peas adapted to the different orchard regions. Occasionally, we have followed a crop of cow peas with a crop of corn. During the last cultivation of the corn more peas are sown or hairy vetch. The vetch supplies a fine crop for plowing under in the spring. Vetch also becomes a profitable pasturage crop for hogs when their age and size will permit pasturing them without injury to young trees. On this subject of hairy vetch, Agrostologist F. Lamson Scribner in 1895 reported:

“Hairy vetch sown in autumn will cover the ground and prevent washing during the winter. It is one of the best crops to turn under as green manure. Do not commence to feed hairy vetches until they have begun to bloom. Like most of the bean and clover family they are somewhat diuretic if fed in large quantities before mature. Use caution in feeding until the animals have become accustomed to the change of feed.”

Peas may be utilized in the same way—just as you would clover. We have occasionally used a crop of red clover but its use is too familiar to need further comment here. We have also used alsyke clover, which in some cases is better than red clover.

Some sort of cover crop throughout the winter not only prevents washing, which is so disastrous, but holds the winter snows, and lessens the depth of alternate freezing and thawing. Also in gathering the crop in the fall, it makes picking and hauling of fruit a much cheaper and cleaner job.

The rapid growth induced by cultivation through the first of the season is inclined to make the new wood of the trees soft and tender. To check this growth and harden the wood for winter, a cover crop is necessary. The weeds or volunteer grasses might be allowed to

fulfill the same purposes, but they do not add the same amount of fiber to the soil, and they certainly add absolutely nothing in the way of nitrogen from the air.

During several years I have traveled over considerable country, particularly the Ozark region of Missouri and Arkansas, and I may be pardoned for stating that the strongest, healthiest, most vigorous growth I saw on these trips was in our Rolla orchard thus cultivated. And I believe that in a generous use of cover crops in orchards throughout the state, particularly on the thinner soils, the value of the crops may be continually increased. Also the life and productive age of the orchard materially increased.

Rye has been used to a limited extent, but it has not been so successful a crop in the Rolla country as peas, vetch and clover. When the trees are getting too much nitrogen, the growth is rank and succulent; cover crops are just as necessary but rye or some other non-leguminous crop should be used. It gives humus and protection without adding more nitrogen, and also serves as a check which helps the formation of fruit buds.

The growing of Spanish peanuts in young orchards is worthy of a trial. We have also used velvet beans, which we believe are adapted to conditions further south where the season is longer and will mature the crop.

Needs of Northwest Soils

During the past season, in company with Mr. Irvine, editor of the "Fruit Grower," I visited the orchard regions of Colorado, Utah, Idaho, Oregon, Washington, and Montana. We made it a point to inquire about cover crops. Generally our Western friends all admitted that they knew little about them and felt their need, some had had little experience with clover. Their soil, rich in minerals, is often deficient in humus. This is one of the greatest problems they have to solve, and is one to which they should give far more attention.

There are many forms of mineral plant food in the soil which are not available to many of our cultivated plants. Even under the best conditions they have not

the power to use them. On the other hand, certain of our cover crops can digest these less available foods, and when they decay leave them in the form convenient for other weaker plants.

Work of Deep Rooting Plants

Many plants cannot work below the surface layer of the soil, that is, they cannot go down into the subsoil. Subsoil contains a large amount of mineral; in fact, the surface layer is merely a subsoil to which humus has been added by the growing plants. This subsoil is very rich in the necessary elements, and it is the clovers and other cover crops which send down their roots into this subsoil and bring to the surface foods which other plants cannot reach. They not only bring these foods to the surface but the roots remain down there and decay. Eventually the subsoil is incorporated with the surface soil or, in other words, the surface soil is made deeper by these roots working around in the subsoil, loosening it up and adding humus to it.

The higher elevations are not adapted to the growth of cow peas, but doubtless our plant breeders will give us hardier strains and varieties adapted to every condition. Clover can be used advantageously, but perhaps it is not the ideal crop for these localities where intensive cultivation is practiced. The hairy vetch is probably one of the very best crops suited to such method. Intensive clean culture can be given until mid-summer, then sowing vetch and turning it under the following spring. We have found Canadian peas a most desirable cover crop in the Genesee valley of New York. These peas are also utilized very largely in New Mexico. This is a great crop for the fattening of lambs and hogs, and here is a suggestion that may be of some value to the West. Grow these peas as a crop for the fattening of sheep and hogs, thereby manufacturing at home a most valuable brand of fertilizer which is one of the most effective methods of supplying the humus required by Western soils.

While in the West we noticed a few orchards sown in clover and for partial cul-

tivation they plowed a strip and left a strip. The strip left standing thus became a seeder for the strip turned under, and so caused fairly good cultivation.

Captain Shawhan of Payette, Idaho, the products of whose orchards attracted most favorable attention and some blue ribbons at the Council Bluffs Apple Show, and also at the Spokane Apple Show—believes in cover crops, and the adding of humus to the soil, thus feeding his trees. He says when he takes such wondrous crops of fruit from his trees that he feels in duty bound to give them something in return. Therefore, in addition to cover crops he makes generous application of barnyard manure, and the soil is so porous and loose that in walking through the orchard one sinks to his shoe tops.

Commercial Fertilizers

In planting a later addition to the Rolla orchard, consisting of 15,000 trees, mostly one-year, but with some two-year, we applied to each tree several pounds of Commercial 583 and bone meal. Every tree lived, not *one* failed to grow and all made a most vigorous growth. Planters of Western orchards on land deficient in humus have supplied the deficiency by this method rather than lose a year's time in the cultivation of some crop. We suggest that each tree be given, at the time of planting, several pounds of sheep or other manure, or some commercial brand of fertilizer, as may be convenient. Abundant humus may then be supplied by the cover crop to follow. This method is also suggested for old lands lacking in fertility. The money and time spent in applying a stimulant will prove a profitable investment.

WILLIAM P. STARK,
Louisiana, Mo.

Cover Crops for Eastern Conditions

There are two distinct classes of cover crops. There are those that live over winter and commence growing in the early spring, like the clovers, vetches, and rye, and those that die down in the fall, like cow peas, soy beans, turnips, rape and buckwheat. Many of those of the latter class make a very large growth and in

many respects are superior to those of the former class. The winter cover crops, however, furnish better protection to the soil and roots during cold weather, and on the whole are better suited to New England conditions.

Cover crops may also be classified according to their ability to contribute to the supply of plant food in the soil. Plants belonging to the legume family, such as clover, alfalfa, vetch, peas and beans, have the power of assimilating nitrogen from the air and when turned under contribute to the supply of this valuable form of plant food. It will be observed that some of these nitrogen-gathering crops belong to the winter group and some to the fall group. Under certain conditions a non-leguminous crop may be more serviceable than a nitrogen-gathering one and in like manner a fall cover crop may often be just as useful as a winter one. If the trees were not making sufficient growth a leguminous crop would probably be desired, while if the trees were making sufficient growth and there appeared to be a lack of vegetable matter in the soil, a rapid growing non-leguminous crop, such as winter rye, would be more suitable. In locations where good covering of snow may be depended upon and where soils are not likely to wash, a fall cover crop such as turnips, rape, buckwheat, cow peas, soy beans, or horse beans would be very suitable. The three last named crops are nitrogen-gatherers and would be more suitable than the former three, if the trees were not making satisfactory growth.

Oats, barley and corn are occasionally used as cover crops, but have very little to commend them. They draw heavily upon the moisture of the soil when the fruit is maturing and are likely to affect the yield seriously.

Turnips and rape are very similar and are sometimes used for cover crops. They are more useful when sown in combination with clover than when grown by themselves. They continue growing late in the fall and furnish good protection to the clover plants. Their chief value lies in their ability to attack and break up insoluble compounds that other plants can-

not use Whether grown alone or in combination the greatest care should be exercised in using just the right quantity of seed. Those who have not had experience in sowing turnips and rape are almost sure to use too much seed. Not more than one pound of turnip seed should be used to the acre, except with the cow-horn type Six pounds of rape seed to the acre is sufficient.

Buckwheat

Buckwheat, like rye, is a dependable crop and is largely used by the apple growers of Western New York. It has a pulverizing influence upon the soil and is useful in "smothering" weeds. It does well on almost any kind of soil, and on account of its ability to grow on very poor soils is often called the "poor man's crop." The "poor farmer's crop" would seem to be a more suitable appellation. It is not advisable to sow buckwheat in an orchard until August 1st, or later. If sown earlier it may mature its seed before frost comes and such seed will cause trouble in the spring. Buckwheat contributes to the soil very little vegetable matter, for after the first frost it is difficult to find the remains of the crops.

Rye

Rye is probably the most reliable of all cover crops and among those of the non-leguminous class it is the most satisfactory. The most important requirement of a cover crop is that it makes a cover and where other crops fail rye may usually be depended upon. The greatest objection to this crop is that it sometimes makes such a large growth in the spring that it is difficult to turn it under. This seldom happens except with the farmer who is habitually behind with his work.

Legumes

Canada peas, soy beans and horse beans are sometimes grown as cover crops. They are nitrogen-gatherers and belong to the fall group. For a Connecticut condition none of them is so well adapted as the cow peas.

Cow Pea

By many orchardists the cow pea is regarded as one of the best plants for cover crop purposes. Of the autumn group it

is undoubtedly the most satisfactory. It is a hot weather plant and thrives remarkably well on light soils and in dry seasons. This is an important point in its favor, for it is a common occurrence to have very dry weather about the time the cover crop is expected to make its growth. The seed may be sown broadcast, or it may be drilled in. The variety "Whippoorwill" is probably the best for cover crop purposes. A combination of cow peas and clover makes an ideal cover crop. The former should be sown in drills about two feet apart and not later than the middle of July. About the first of August the clover should be sown broadcast between the rows and harrowed in. This harrowing will be of great benefit to the cow peas, giving them a good start. In very dry seasons the sowing of the clover may be deferred and cultivation may be continued between the rows. If deferred too long the clover is not likely to become well established before winter sets in and is likely to be killed before spring. Under such conditions rye would probably give best results. About one bushel of cow peas and 12 to 15 pounds of clover seed will probably be about the right quantity per acre. When frost comes the cow peas will be killed, leaving the clover in possession of the ground.

Hairy Vetch

Hairy or winter vetch in many sections is becoming a popular cover crop for orchard purposes. It is an annual and thrives well at low temperatures. It belongs to the nitrogen-gathering group and owing to its prostrate habit of growth and its habit of growing in late fall and early spring, is well suited to cover crop purposes. It is better adapted to heavy soil, but when sufficient attention is given to the preparation of the ground, will thrive remarkably well on the lighter soils. The harvesting of the seed is a difficult operation, especially in New England, and for this reason the seed is usually very high in price. Some orchardists have been able to grow their own seed by sowing rye and vetch together. The rye supports the vetch, facilitating the work of harvesting.

Clovers

The clovers make good cover crops and in this section of the country are more generally used than anything else. Some prefer the mammoth clover on account of its making a larger growth. Others prefer the common red clover, while still others pin their faith in alsike. Crimson clover is largely used and in sections where it may be depended upon to stand the winter, is undoubtedly the best of its class. It is a very rapid grower, but in most sections of New England it is likely to winter-kill and for this reason is not generally recommended. The safest plan probably is to mix together two or more kinds, always including a little crimson. Some growers prefer to mix in a little turnip seed. The turnips grow rapidly and protect the young clover plants from the hot sun. A suitable mixture may be made up as follows:

Mammoth clover	6 pounds
Crimson clover	6 "
Alsike clover	3 "
Cowhorn turnips	3 ounces

Alfalfa is so exacting in its requirements and so slow in starting its growth, that it is seldom used for cover crop purposes, except in combinations.

A close examination of the orchard soils of New England reveals a marked deficiency in vegetable matter or humus. There is no more effective way of increasing the amount of humus and the ultimate fertility of the soil than by the judicious use of cover crops.

Any crop that is sown in the orchard for the purpose of turning under in the spring is called a cover crop, and should not be confused with what is commonly called a "catch crop," which is grown to be harvested. Catch crops are commonly and profitably grown in young orchards before the trees require the whole area.

Quantity of Seed Per Acre

Mammoth clover	12 pounds
Common red clover.....	12 "
Alsike clover	12 "
Crimson clover	15 "
Alfalfa	20 "
Cow peas	90 "
Soy beans	90 "
Horse beans	90 "

Hairy or winter vetch	50 pounds
Summer vetch	60 "
Canada peas	90 "
Rye	90 "
Buckwheat	60 "
Rape	6 "
Turnips	1 pound

In the selection of a cover crop there are so many matters to be considered that some of them are likely to be overlooked. The following score card may serve to keep the various points in mind and to give some idea of their relative importance:

Score Card for Cover Crops

Chemical influence:

- (a) Addition of plant food 10
- (b) Retention of plant food (that used in growth and that saved from washing) 15
- (c) Influence on nitrification ... 5

Physical Influence:

- (a) Addition of humus 10
- (b) Mechanical influence (action of roots) 10
- (c) Effect on soil moisture (its influence on the retentive power of the soil and its ability to utilize the surplus moisture in late summer and to hold the snow and rain in winter and early spring) 10

Protective Influence:

- (a) Protection to roots from injurious freezing and thawing (1st, by the growth of vegetation; 2nd, by its ability to hold the snow and leaves)..... 10
- (b) Protection to fruit (by serving as a cushion for windfalls).... 5

General Considerations:

- (a) Adaptability (to soil, climate, purpose, etc.)..... 10
- (b) Reliability (its ability to produce a good cover under varying and adverse conditions).... 10
- (c) Cost of seeding..... 5

C. D. JARVIS,
Storrs, Conn.

Canada Field Pea as a Cover Crop in the Rogue River Valley

The Canada field pea is one of the most promising of the leguminous crops for orchards—to meet conditions in the Rogue river valley, namely, delayed rains in the fall and the probability that plowing will have to be done in March.

My experience is limited to a single crop and to a few volunteer plants. I plowed

and harrowed in February, a granite loam, drilled in 100 pounds to the acre the 1st of March. Plants broke surface in three weeks, began to bloom in the middle of May and had ripened seed and were dying by July 1st.

It is most important to inoculate the seed as the test plot represented a failure—plants pale, small leaved, 18 inches long, shed bloom. Inoculated plants luxuriant, dark green, five feet long in places and well fruited.

Our season was wet and the orchard young, so plants were allowed to mature and harvested. Thrashed out 700 pounds of seed to acre and had a ton of straw, which made good horse feed for wintering. This crop could have been turned under the 1st of May when it averaged 30 inches in height. Volunteers followed this crop appearing mostly in late September and growing 12 inches. The severe winter killed all, and the native weeds, turnip and alfalfa also winter-killed.

When planted in the fall and if rains come early one would have a good crop of vines to plow under even if it winter-killed.

With irrigation it would be a splendid crop to sow in spring, then irrigate and plow under in May or June.

GEO. B. DEAN

INTERCROPPING

There can be no objection to the growing of crops between young trees and thus utilizing the land which is unoccupied and likely to remain so for several years provided care is taken not to crowd the trees and not injure them by cultivating too closely and peeling the bark, and provided as much is put on the land in the form of fertilizers as is taken off by the crop. The average man will not do this, but will take off crop after crop and put little or nothing on in return; however, if he will make proper use of manure he can grow crops between his young trees, make a living off the crop and improve the soil at the same time. Cropping is not injurious to the land any more than milking is injurious to a cow, but to crop the soil without fertilizing it is like milking the cow without feeding

her. This process may be kept up for a while without visible exhaustion, for the soil is a storehouse of plant food which has, in some cases, been hundreds of years in accumulating, but if it is kept up too long exhaustion is sure to follow. It must, therefore, be understood that if we are not to rob the soil of its productivity and deprive the coming generations of their right to a living from the land, we must conserve the fertility of the soil which they will in the future cultivate.

Plan for Yakima Valley

The following plan is suggested for North Yakima, Washington. It is subject to modification for varying conditions and with new information.

First, we would plant apples as the permanent crop to live and to bear for one hundred years. This may seem a long time to expect trees to bear, but in New York, Pennsylvania, Ohio, New England and Canada there are bearing apple trees one hundred years old. It must be remembered, too, that these trees have never been properly sprayed, cultivated or pruned. They have simply happened to be where the soil and moisture conditions are good. In a country where the soil is deep, where there is plenty of water, and where trees receive proper pruning and care, there is no question but that they will bear profitably for a long period of years. We would select winter apples because they will find a wide market. We would select three or four varieties to insure fertilization.

We would, at this point (North Yakima), select Spitzenburgs, Delicious, Newtowns and Winesaps. At a higher altitude we would select Jonathans, Delicious and Rome Beauty. At a lower altitude we would select Winesaps, Newtowns and Arkansas Blacks. However, it is impossible to please others in selections, and with more information, we might change our own views.

Distances to Plant

We would plant the apples two rods apart each way. This may seem like a waste of land, but remember that these trees are expected to stand a long time,

and the land between the trees is to be utilized by the planting of "fillers" and the growth of vegetables. By "fillers" we mean other varieties of trees between the rows. We are presuming that apples will be the main crop, and that everything is to be subordinated to the idea of producing a permanent apple orchard that will live and bear perhaps one hundred years, but "fillers" may be planted with a view to sacrificing them when the apple trees need the soil and sunshine.

Peach and Pear Fillers

* We will suppose that the square method is chosen and that the trees are planted two rods apart each way. This makes on one full acre of land 40 trees, and on ten acres, 400 trees. We would then plant the same number of rows of pear trees midway between the rows of apple trees, and plant them one rod apart. This gives 80 pear trees per acre, or 800

* For other methods of planting, see article on "Laying Out the Orchard."—Ed.

trees on ten acres. We would then plant as many peach trees as apple trees midway between the apple trees, making 40 peach trees per acre, or 400 on ten acres. This gives, in all, 160 trees per acre, one rod apart, or 1,600 on a full ten acres.

Many would not plant peaches, and their objection is that peaches are different in nature from apples and pears; that they grow with spreading branches, rendering it difficult to work and cultivate among the trees. It is also claimed that spraying apples and pears for codling moth often specks the peaches and injures them. We have fully weighed these objections, and do not consider them important as compared with the fact that the peach is a rapid grower, an early bearer and ordinarily profitable. The fact that it is of a different nature from apples and pears and extracts different food substances from the soil is in its favor, because it does not compete so strongly for the same food. The fact that it grows with spreading branches may be remedied largely by pruning. The diffi-



Fig. 1. Onions on New Land.

culty of spraying we have not found to be serious.

Variety of Pears

As to the variety of pears, we would plant Bartletts, because they are the earliest bearers, heaviest bearers and up to date best money-makers. However, the Anjon Bosc and Winter Nellis are excellent varieties.

As to the varieties of peaches, we would plant Early Crawford and Elbertas—the Crawford because it is out of the way before the Elberta is ripe; the Elberta because it is a good shipper and seller. Besides it ripens at a time before apples have to be picked, and therefore distributes the work more evenly through the fruit season.

Kind of Crops to Grow

We now have the orchard planted, and will suppose that one-year-old nursery stock has been used, that we have three kinds of apples, two kinds of peaches and one kind of pears. The trees are one rod apart each way, and 160 trees per acre.

There is no income from the fruit trees, but there is unused land, which with proper cultivation will grow vegetables

that find a profitable market. What can be grown during the waiting period that will make a living for the family? Strawberries, blackberries and raspberries yield profitable returns; but it takes one year of waiting from the time of setting to get a crop. It takes one year with rhubarb and two years with asparagus. Here are one or two years of waiting, and we are supposing that the orchardist wants profitable returns the first year. What should he plant?

Onions on New Land

The answer to that question depends on the soil, the climate, the market, the grower, and various other circumstances. On new, rich land, we have found onions to be a very profitable crop. Most producers say that onions should be grown on land that has been worked for several years, because by cultivation the soil is brought into a condition that is better adapted to the onion. There is some truth in this statement, but our preference for the new land on which to grow onions is because of the little difficulty of weeding when the onions are small. The young onion is very small. The little tender



Fig. 2. Field of J. B. Early, Grandview, Wash., 30 months after setting out. Phillips Cling Peach planted in Spitz-Winesap orchard set in apple row to create wide spaces between rows to allow for growing money crop while trees are growing. Mr. Early has made his place pay from the beginning.

sprout is scarcely discernible from grass at the first; it grows slowly too, and requires a great amount of hand weeding where the soil is full of weed seeds, and where the weeds spring up rapidly after spring plowing. This hand weeding is very difficult work. If it is done by adults, they must be for hours in a stooping posture or walk on their knees along the rows.

Onions grow well on sandy soils and on volcanic ash soils. Land that has been recently cleared of sagebrush is good for onions, because there the onions grow to a large size, and the first year, especially after the sagebrush has been grubbed, there are no weeds of any consequence to interfere with cultivation; the labor cost is low. Only the ordinary tools need to be used and the returns are thus relatively large.

Cantaloupes

Cantaloupes have been successfully grown between the trees and are adaptable to many soils and climates, are of fine quality, are easily grown, and if planted soon enough to find an early market, bring very profitable returns.

Watermelons

Watermelons are sometimes grown, but the difficulty is generally that the trees require more water than is required for the watermelon. In fact, after the watermelon is formed and as large as a man's fist, it requires very little water, and is of better quality without it, while the trees need water throughout the season. Many of the failures to produce good watermelons on damp soils or irrigated lands grow out of the fact that the vines get too much water. Some persons suppose that because the watermelon is mostly composed of water and because of the name, it should have a great amount of water. This is a mistake, and for the reason that the watermelon rind is tough and solid, allowing very little evaporation, nearly all the water pumped by the root system and carried into the melon is retained as if it were pumped into a jug. It is not that the melon receives more water than the leaves that causes it to be so juicy in the autumn and the leaves to be dry, but it is because the leaves have given up their water by the process of evaporation and the melon has not. It is therefore necessary to exercise



Fig. 3. Mr. Early's Watermelon Patch. Cleared of sage brush in February, plowed in March, planted in May, crop in August.



Fig. 4. A Heavy Crop of Vegetables is Permissible in a Young Orchard Where Proper Attention is Given to Fertilization.

care not to give the melon too much water after it is once started and the young melon is well formed. This is not true of cantaloupes although cantaloupes and watermelons are frequently grown on the same ground or in adjacent rows. On the other hand it probably takes twice or three times as much water to grow onions as to grow watermelons. They need more than is usually given to the trees, while the melons need less, consequently if care is observed to give the onions enough water the trees are not likely to suffer.

Potatoes

Potatoes are easily grown and are a fairly profitable crop, yielding sometimes as high as \$200 or \$300 per acre. The price of potatoes fluctuates greatly. We would especially recommend potatoes if the land has been in alfalfa or clover previous to setting the orchard. It is not uncommon for potatoes to bring \$30 per ton one year, and the next year scarcely pay the cost of growing. The rule is that if potatoes are very high in price one year they will be low the next year and not a profitable crop. Many old farmers say, "When seed is cheap, plant potatoes; when it is high, sell your seed."

This rule is not infallible, for we have seen it fail; but it is so nearly true that in an average of ten years, the profits to the growers who follow it will be much larger than to those who plant without any observation as to whether seed is high or low.

Tomatoes

Tomatoes are a very profitable crop in soils and under conditions to which they are adapted. In some countries they blight to such an extent that the returns are uncertain, but where they can be grown successfully and without too much risk, and close to the market, they yield large returns. We have known in exceptional cases profits of \$600 to be gathered from one acre of tomatoes. Again, we have known them to fail entirely, so that the profits may be estimated at from nothing to \$600 per acre. How to prevent tomato blight will be treated in the article on tomatoes.

Cucumbers

Perhaps no truck crop will bring larger returns for the given amount of labor than cucumbers, provided they are grown sufficiently near the market to be picked and marketed every day. One man marketed in one year from one acre of land

over \$1,000 worth of cucumbers. They are not difficult to cultivate, pick, crate or market, and therefore in proportion to the labor expended yield enormous returns.

Squashes

Hubbard squashes do well and usually sell at high prices. We have known them to bring \$300 per acre.

Cabbages, Turnips, Etc.

Cabbages, turnips, rutabagas, beets, celery and asparagus are all profitable, and make it possible for a family to live in comfort on ten acres of land while the young trees are coming into bearing. We treat the growth of these crops more fully under their appropriate heads, but we know because we have seen it tried that it is possible both to succeed and to fail, and that success or failure depends on the labor and the intelligence put into the work. We have known a few persons who succeeded so well at growing crops between the trees that they abandoned the orchard idea and turned to the growing of vegetables as paying larger profits in

proportion to the expenditure of money and of labor cost, than fruits.

Small Fruits

Strawberries, currants, gooseberries, raspberries and blackberries are often grown between the trees with varying degrees of success. In choosing among them, we would say that the gooseberry is the least trouble, while the strawberry is likely to prove the most profitable. We have known strawberries to yield \$300 per acre, but it is more likely that the average grower will not receive more than \$150 to \$200 per acre.

Alfalfa

We have tried setting trees in a field of alfalfa by plowing out rows about six feet wide in which to set the trees, and allowing the alfalfa to grow between the rows. We did so on the theory that alfalfa is a nitrogen gathering plant and fertilizes the land, and that the hay crop would pay good returns. If this plan is adopted there will be a strip of about 24 feet of alfalfa provided the trees are set 30 feet apart. Thus five-sixths of the land



Fig. 5. Combination of Strawberries and Watermelons. Strawberries between the rows and watermelons in the rows. *Courtesy of O.-W. R. & N. Co.*

is in alfalfa, and one-sixth of it plowed and cultivated for the growth of trees. With each succeeding year the plowed strip will be a little wider and the alfalfa will be a little narrower, inasmuch as we would endeavor to plow the land about as rapidly as the roots of the tree would extend out in the direction of the center of the row. This plan seemed to work well, except for the difficulty of irrigation, where irrigation is practiced, but there is no question that the soil is improved by the growth of alfalfa, and that it will yield a profitable crop while the trees are coming into bearing. That which is true of alfalfa is also true of clover, insofar as improving the soil is concerned, but as a hay crop the clover is perhaps not so profitable.

Profits from Vegetables

Mr. Alexander Miller, a gardener at North Yakima, Washington, gives the following figures as possible net profits per acre from various crops:

Cucumbers, ground heavily manured, per acre, per annum.....	\$1,000
Tomatoes	1,000
Asparagus	1,500
Rhubarb	1,500
Celery	1,500
Horse Radish	1,500
Early Potatoes	500
Peas	500
Turnips	300

Turnips may follow a crop of early potatoes or peas the same year, and that brings the productive value of the land up to \$800 per acre.

The rutabagas are about as profitable as turnips and either will yield large returns in proportion to the labor costs.

These yields are exceptionally large but knowing Mr. Miller to be an exceptionally good gardner we do not doubt the figures.

How to Arrange the Rows

The plan here given is merely suggestive, and may be varied to suit the conditions or the opinions of the planter. Suppose, however, we plant rhubarb, asparagus and strawberries midway between the rows of fruit trees, one-third of each. We will have to wait for them to bear, but they are very hardy and very profitable, if well fed. This places them one rod

apart and one-half rod from each tree row on either side. In spraying, the team and wagon can be driven astride these rows, and will not injure them in the least.

First Year

We have now aranged for a profitable crop, one year from planting, but nothing the first year. Between the rows of vegetables now planted, and the trees, may be planted onions, peas, cucumbers, tomatoes, cantaloupes or celery. Ten acres planted in this way ought to yield a living much larger than the average family of the United States receives and larger than the profits from the average farm. This is the critical period, for it is the first year and the one of the least income.

The next year these crops may be varied, except that the rhubarb, asparagus and strawberries remain standing until such time as the trees need the land.

Second Year

The second year the same arrangement as the first may be followed or the crops may be varied. This year the asparagus will bear a little and the rhubarb and strawberries yield profitable returns.

Third Year

The third year, any arrangement may be followed that suits the grower, because there are three crops, namely, asparagus, rhubarb and strawberries that will yield good returns. This year the 400 peach trees should yield \$3 to \$5 per tree. This will, in the aggregate, make a fair living.

In this estimate of profits from peaches, I am presuming upon fair market conditions. During the seasons of 1912 and 1913, we have had rather poor markets, not because peaches did not sell for good prices to the consumer, but because of poor systems of distribution. I have known peaches to yield \$1,000 per acre; again they would not pay the costs of production and marketing.

Fourth Year

The fourth year we would not advise any vegetables between the trees except the three permanent crops of asparagus, rhubarb and strawberries. This year four-year-old peach trees will yield from \$5 to \$10 per tree and the pears will

bear a small crop. This, together with the vegetables, should bring good returns.

Fifth Year

This year the peaches should yield large returns and the pears begin to pay. There will also be a few apples, say \$1.50 per tree. At this rate, 400 trees should bring \$600. There will also be an income from the vegetables. However, the peach tree grows with spreading branches and will begin to intrude upon the strawberries and vegetables, yet at this time we would not sacrifice the vegetables, but prune the peach trees so as not to interfere too much with them.

Sixth Year

From this time forward peaches, pears and apples will yield good returns and the question of sacrificing the vegetables may well be considered. There is income enough without them, but if they still prove profitable, the grower will hesitate. Some people say that vegetables should not be grown among the trees because the trees need the soil's substance. This is true if the ground is not manured; but if the vegetable matter taken off the land is replaced by an equal or greater amount of barnyard manure, it improves rather than impoverishes the soil.

From this time on, the grower has a comfortable income that should net him not less than \$500 per acre per annum, and he can cut out his vegetables and fillers when it seems wise to do so.

After the vegetables are disposed of and the land well manured, then some kind of cover crop should be grown among the trees.

GRANVILLE LOWTHER

Plan for Eastern States

In newly planted orchards the trees occupy a very small portion of the ground, and as a rule some other kind of a crop is grown in the open space. The amount of space at the disposal of other crops will depend somewhat upon the kind of filler chosen.

If peaches are used as fillers the ground should not be cropped for more than one or two seasons. Some reputable growers do not believe in attempting to grow any

other crop, except cover crops, when peaches are used as fillers. At least one grower in Connecticut has had excellent results from growing turnips, another has found late cabbage profitable. In some cases the spaces between the trees are planted to small fruits—strawberries, raspberries, blackberries, gooseberries and currants. Where no fillers are used the small fruits are very suitable. With apple fillers strawberries may be successfully grown, but the bush fruits, if used, are likely to be left in too long.

The best kind of a crop for this purpose is one that will require cultivation the early part of the season and will be out of the way in time for the sowing of a cover crop. Crops of this nature are early cabbage, early cauliflower, early potatoes, beans, peas and radishes. Next to this is one that will require cultivation the early part of the season but will not necessitate the disturbing of the soil late in the season. Late cabbage, squash, turnips, cucumbers and melons are of this class. A cover crop may be sown when such interplanted crops are last cultivated. Late potatoes are not suited to the purpose, for the reason that in digging them the soil is much disturbed, producing a late growth and preventing the trees from properly ripening their wood. Corn has been grown in this way but usually has a bad effect upon the trees. It may be used without fear of injury if a wide space is left and kept cultivated along the rows of trees. The whole may be seeded to clover about July 15th, or at the last cultivation of the corn.

Whatever is grown in the orchard it should be looked upon as a catch-crop, and the returns from it as incidental. On the other hand, these companion crops, with careful management, may be made to pay for the care of an apple orchard up to the age of profitable production. An extra supply of fertilizer always should be applied for the use of these supplementary crops and the greatest care exercised in preventing them from interfering with the growth of the trees. From year to year the space for the use of the trees should be increased until finally it is given up entirely.

Fruit Trees as Fillers

The ideal filler is a quick-growing and early maturing tree that will produce the maximum amount of fruit within the few years that it has to live, and one that will least affect the welfare of the permanent trees. As soon as the fillers begin to interfere with the natural growth of the permanent trees, they must be removed. There is a difference of opinion with regard to the use of fillers. The chief objection raised by those opposed to the practice, is that the fillers are likely to be left too long, resulting in injury to the permanent trees. Such a result, in reality, would be the fault of the man rather than that of the system. The grower, for the benefit of the remaining portion of the trees, cuts out superfluous branches, so why should he hesitate to remove superfluous trees when by so doing the remaining trees will be benefited? In either case it is simply a case of removing part of his fruit-bearing structure for the sake of getting better returns in the future. It should be remembered in this connection that the fruit is borne largely on the surface of the tree, and that when the tree becomes crowded together the surface is very greatly reduced. Assuming that the grower knows when fillers should be removed and that he has the courage to remove them, the question to be decided is whether it is more profitable to use fillers or to use the space between the rows for growing vegetables, small fruits, or other crops.

In Connecticut the peach is more largely used for interplanting than any other kind of fruit tree. In many respects the peach is well suited to the purpose. It matures early and fair crops are often obtained three or four years after planting. The objection to this kind of filler is that the treatment for bearing peach trees is somewhat different from that demanded by young, growing apple trees. If the apple trees should suffer from this cause it is again the fault of the man. The grower should keep in mind that in such case of mixed planting, the apple is entitled to first consideration and the filler should be regarded strictly as a secondary matter. Plums and cherries are open to the

same objection raised against the peach, but it is probable that any of these stone fruits in the hands of the intelligent fruit grower may be successfully used as fillers.

The use of early maturing varieties of apples as fillers has been strongly recommended during recent years. The apple makes a slower growth than the peach and returns come in much more slowly. This objection is offset however, by the fact that the apple filler may be retained in the orchard much longer and a great many more crops secured. Five or six and often as many as ten crops of apples may be secured, while it is seldom that more than two or three crops can be taken from peach fillers without injuring the permanent trees. The profit from two crops of peaches is very likely to exceed that from the many apple crops, but it is not fair to judge their relative value from this standpoint only. The apple fillers may have a better influence on the permanent trees and, on account of their slower development, may permit the growth of other crops between the rows for several years. The apple filler is more satisfactory where the permanent trees are widely spaced and it is entirely unsuited to closely planted orchards.

The small growing and early maturing varieties such as Yellow Transparent, Oldenburg, Bismarck, Wealthy, Wagener, Ontario and Missouri Pippin, are the most suited to use as fillers. Jonathan may also prove to be desirable for this purpose. Ben Davis and Gano are largely used as fillers in some sections, but on account of their inferior quality, they are not recommended for planting in New England. There is little difference among the varieties of peaches for this purpose. The pear, on account of its susceptibility to blight under intense cultivation, is not suited to interplanting.

Many fruit growers have the necessary intelligence and courage to handle successfully an orchard on the filler system. But there are undoubtedly some, who for the sake of earlier returns, are likely to favor the fillers at the expense of the permanent trees and for the sake of getting one or two additional crops, are likely to injure seriously the shape of the trees

of the main planting. The growers of the latter class are advised to set their trees at moderate distances and to grow among them some kind of a crop such as potatoes, corn, or vegetables that require cultivation during the early part of the summer. Even then, there is danger of growing these crops too near the trees and of not supplying the necessary plant food to make up for that removed from the soil by the secondary crop.

C. D. JARVIS,
Storrs, Conn.

Tillage with Intercropping

The system of tillage and intercropping is generally practiced in the orchard before the trees arrive at a profitable bearing age, and after it has served its purpose is usually succeeded by tillage and cover crops. The growing of companion crops or intercrops in the young orchard affords the orchardist an opportunity, by careful management, to make such crops pay for the care and management of the orchard during the period elapsing between the time of setting the trees and the age of their profitable bearing. The kinds of crops which may be grown in the young orchard are only limited by the climatic and soil conditions. Generally speaking, however, they should be restricted to hoed crops. Vegetables and small fruits are the most desirable. The writer prefers vegetable because the orchardist can choose such crops as may be planted rather late and still mature a crop, thus permitting early and unrestricted cultivation of the soil for a short time before planting, thereby furnishing moisture and plant food to the tree when it is making its most vigorous leaf and wood growth. Such crops as late cabbage, squash, cucumbers, beans, tomatoes, etc., may be used to good advantage. Corn and potatoes may be grown if not planted too close to the tree rows. Strawberries are preferred among fruits followed by the bush fruits—currants, gooseberries, raspberries and blackberries. The objection to these crops is that their season of growth is practically identical with that of the apple tree, and that unless, as has been said, they are planted at some

distance from the rows, they are apt to deprive the young trees of needed moisture and plant food. The successful practice of the intercropping system is wholly dependent upon the intelligence displayed by the orchardist in furnishing a sufficient amount of plant food to meet the extra demand made upon the soil by both tree and companion crop, as well as upon the intelligent selection of intercrops. For the past four seasons the writer has grown Hubbard squash upon certain portions of the young station orchard. The squash is usually planted about June 17-20 and as yet has not failed to mature a crop. This late planting permits unrestricted cultivation of the orchard practically up to July 15, or later if desired, as the vines do not begin to run much before that date. The returns from an intercrop will of course vary with the kind of crop grown, the care and fertilization, and the market. Owing to an almost total failure of the crop throughout New England the Hubbard squash intercrop grown in 1907 in the station orchard, returned about \$150 per acre. The average receipts for four seasons have approximated \$75 per acre. Of course such results are possible only where a good home market is available, and are not to be expected from shipments to larger markets where charges for freight and commission, as well as competition, serve very greatly to reduce the profits.

WILLIAM STUART,
Burlington, Vt

Fillers

E. H. Favor, author of "The Fruit Growers Guide," on the subject of "Fillers" says:

"The use of 'fillers,' or temporary trees, in an orchard is not always to be recommended. Such trees can in many instances serve a useful purpose, but they too often become permanent. After they come into bearing the owner always wants just one more crop from them before they are removed. Years pass by in this way and the orchard becomes so crowded that the yield from all the trees is less than it would be if the fillers were out.

"When the kinds of trees to be used as fillers are carefully selected and then removed at the right time they can be made profitable. Peaches can sometimes be used as fillers in an apple orchard, if the soil and climate are suitable. Pears are not advisable as fillers, especially in an apple orchard, on account of their susceptibility to fire blight, which can be communicated to the apple trees. Quick maturing varieties of apples make the best fillers in an apple orchard, and especially so if the fillers have an upright habit, such as Missouri Pippin, Wagner, or Rome Beauty. Such kinds can be handled to advantage in an orchard laid out on the rectangular plan, with the filler in the center of the square. This will double the number of trees per acre, and give each tree the maximum of room. It is not so easy to plant fillers to advantage when the orchard is laid out on the hexagonal plan without crowding the trees.

"A common and satisfactory method of arranging fillers is to set the permanent apple trees 30 feet apart, with a filler midway between the trees in one direction only. This will put the trees 15x30 feet apart.

"While good returns can be made from the fillers in an orchard, it is safe to say that practically as good returns can be made by using crops of other kinds. In small orchards some of the small fruits, such as strawberries, blackberries or currants, are good money makers. In large orchards, it is better to grow some kind of cover crop and work toward building up a large framework and strong trees that will be heavy bearers when they come into fruiting, rather than to try to get an extra amount of fruit from the temporary trees.

"One of the great dangers of intermixed planting is that nine persons out of ten will not take the fillers out when they ought to. There is danger in it to the whole enterprise and the system should be recommended very guardedly, if at all. Peaches should not be planted among apples as a rule. It is better to stick to one kind of fruit."

Double Planting for Middle States

The plan of double planting the orchard is sometimes followed. The fundamental idea of this scheme is to plant temporary trees between the permanent ones with the idea of removing them when they begin to crowd. By this double cropping early returns may be secured. The peach, for example, begins to bear in about three years, while the apple requires from five to eight years where the method of double planting is followed, it is probably best to adhere to the same class of crops. In the apple orchards, for example, use some early bearing variety such as the Wealthy or Missouri Pippin as the filler. The plan of using mixed crops has a disadvantage in that different fruits require different cultural treatment. The peach leaf, for example, is tender and injured by the spray of the standard strength for the apple. The same thing is true of the Japanese plums.

The most serious objection to double planting is the fact that the temporary trees are usually permitted to stand too long and the permanent planting seriously injured. Before the outer branches begin to touch, the filler trees should be promptly removed. Otherwise the trees enter into competition with each other and are compelled to battle for their existence. The longer they are allowed to stand after reaching this condition the more intense the struggle becomes. It is rare indeed that the grower has the courage to cut out these temporary trees. He remembers how they bore last year, and is thus induced to withhold the axe another year. In the majority of instances it is better to grow small fruits as a filler crop, or some annual such as corn or potatoes. These also have the advantage of requiring clean cultivation.

A. T. ERWIN AND G. R. BLISS,
Ames, Iowa.

Safe Rule for Fillers

Peach, and other vigorous growing trees, are unsuited to be used as fillers in an apple orchard, unless confined to the centers of the square. They ought never to be planted in the rows with the apple trees. The only safe rule in the

use of fillers is that nothing shall be employed for the purpose which is more vigorous in growth than the permanent trees, and that the removal of fillers shall be begun as soon as there is evidence of crowding.

Apple Trees the Best Fillers in an Apple Orchard

The best fillers in an apple orchard are apple trees which are upright in habit of growth and begin to bear at an early age. Those of a spreading habit may be used if precocious. The first class is exemplified by the Yellow Transparent and Wagener, which may be planted in the rows, both ways between the permanent trees. Oldenburg (Duchess) and Wealthy may be used, with some caution, in the same manner. Jonathan, Ben Davis and Gano are suitable to plant in the centers of the squares between the permanent trees.

W. J. GREEN,
Wooster, Ohio

Intercropping in New Mexico

The mixing of apple and peach trees in an orchard is sometimes advocated, but in this climate it is not considered advisable. Whenever peaches are planted between apple trees it is done with the expectation of taking the peach trees out whenever they become so large that they interfere with the growth of the apple trees. If this were done there would be no objection whatever to this method of planting orchards, but as a rule the idea is never carried out and the result is that the peach trees are never cut out until they either die out or have injured the apple trees by crowding them out. Very frequently by the time the peach trees are large enough to interfere with the growth of the apple trees they are producing their very best crops, and the orchardist has not the strong heart to go to work and dig them out at that time. Taking everything into consideration peach trees ought not to be planted among apple trees.

FABIAN GARCIA,
Santa Fe, N M

HOW TO MAKE AN ORCHARD PAY BEFORE IT COMES INTO BEARING

BY A. G. CRAIG

Deer Park, Washington

It is very seldom that an apple orchard will yield a crop large enough to net a profit above the expense of the care and harvesting before the orchard is six years old. During these six years the orchard is a constant drain on the finances of the owner, and the interest on the original investment for six years is a large item. The average person starting into apple growing has the above facts staring him in the face, and this problem of how to meet the expenses and at the same time make a living for himself and family has to be solved. The problem of improving the soil or at least maintaining its fertility must also be considered.

The clean culture method has been advocated and extensively practiced in the Northwest, but a large percentage of the fruit growers now realize that it is expensive and the physical condition of the soil becomes impaired in a few years. He also knows:

(1) That the roots of apple trees spread very rapidly, but when not more than eighty-five trees are planted to the acre it takes several years for all of the soil to be filled with apple roots.

(2) That a good farmer improves his soil and at the same time gets a good profit out of it, and

(3) That a field allowed to lie idle and grow up to weeds and bushes for a period of years deteriorates in value.

With the above problems and facts before the grower, he seeks for the best solutions. He says, Why not utilize the land not occupied by trees by using the methods of the good farmer who grows crops and at the same time improves the soil. He hesitates to try because so many have not succeeded. The crops have not been profitable on account of poor management. The trees have not made a satisfactory growth because they were deprived of moisture on account of poor cultivation, poor irrigation or the sapping of the moisture and food by the crops planted too close to the trees. The soil



Fig. 1. Intercrop of Winter Wheat. No crop is placed closer than four feet from the trees.

has been impaired because proper rotation of crops was not practiced and stock was not raised. By avoiding these pitfalls success is inevitable. There have been enough growers who have succeeded in growing good crops and a good orchard on the same land at the same time to demonstrate that it can be done successfully. To do it the grower must study his soil and climatic conditions and adapt his methods and crops to his conditions. This is much easier to accomplish on a small tract than on a large one. With over seven thousand acres of young orchard we have met the problems in part, in the following way. Before explaining let me tell of a few of the local conditions.

Our land in its native state was covered with fir, tamarack and pine. The land is well drained and varies from a sandy loam to clay loam. The rainfall is about twenty inches. We have an irrigation system for bearing orchards but we have not found it necessary to irrigate to get a normal growth on our young trees nor to raise the crops on the ex-

tensive plan of agriculture. Where we use intensive farming, irrigation is necessary.

We began by planting the trees in such a way that a long life orchard would be the result and at the same time give the maximum amount of land available for crops without obstruction by trees. The planting plan is illustrated below.



The trees are placed 17.5 feet apart in the row and the rows are 28 feet apart. Every other tree in the row is a filler (marked x in the illustration). When the fillers are taken out the permanent trees are in triangle, two legs of which are about thirty-three feet and the third thirty-five feet. The wide strips (28 feet) are in the directions with the slope that gives the best results with irrigation furrows.

We make it a hard and fast rule that no crop is placed closer than four feet from the trees. Thus eight feet or more is thoroughly cultivated. Hoeing alone is poor cultivation and it does not pay to just hoe a circle around the trees and put crops on the balance of the land.

We practice clean culture the first year and seed in the fall with winter wheat. After the crop is harvested the stubble is plowed in the fall and remains rough over winter. In the spring of the third year the land is prepared and peas are planted for hogs and seed. The fourth year potatoes are planted on the pea land. We have experimented with and grown many other crops, among them, winter vetch for cow, hay and seed, clover for hay, lentils for seed, trees, rye, oats and garden truck.

Rye, wheat and oats have given the best net returns but never more than one crop in the orchard is allowed. One crop of any of the three will not injure the orchard or land one iota. Some places we have had better success, no doubt due to

the fact that the orchard could be covered sooner after a rain with the cultivator than where all the land had to be cultivated, in the clean culture method.

Wheat—The total cost of the care of the orchard, growing, harvesting and marketing the wheat crop on 1,245 acres was \$12,469.86. The wheat crop brought \$14,263.86 or a gain of \$1,794.00 or \$1.44 per acre above the entire cost of orchard and crop. It cost \$11,426.16 or \$6.43 per acre to take care of 1,777 acres of orchard in about the same condition as the orchard having the wheat crop. Therefore the actual gain was \$1.44 plus \$6.43 or \$7.87 per acre.

Peas—Figuring on the same basis, peas gave a net gain of \$2.23 per acre. This is not a large gain, but when it is considered that the soil was improved, it is actually a large gain.

Potatoes—Potatoes cost us in the pit and storage 38 cents per hundred weight.

Winter Vetch—We have had fair success raising vetch hay and seed, but the greatest benefit has been derived from the



Fig. 2. In the Spring of the Third Year Peas Are Planted.



Fig. 3. The Fourth Year Potatoes Are Planted on the Pea Land.

improvement in the soil. It is difficult to get all the vetch out of the orchard as it volunteers badly, but for an orchard it is not considered a bad fault, but it is not desirable on a general farm.

Clover—Clover has been profitable and is beneficial to the soil, but we have had some trees checked in growth by it. It takes the moisture from the trees more than any other crop we have grown. This can be overcome by careful irrigation, but clover should not be grown in an orchard where water cannot be thoroughly applied in a short period of time.

Vegetables and Small Fruits—We have grown good vegetables in the orchard, but on account of the market conditions we have not gone into it on a large scale. Many families have and are supported in the Northwest by growing vegetables and small fruit in the small young orchard. Where vegetables and small fruits are grown in the orchard, manure should be freely applied or the crops should be grown in a long rotation, or both.

Alfalfa—We have not given alfalfa a good trial, but there are thousands of successful orchards, young and old, in the irrigated districts of the Northwest, seeded to alfalfa.

In conclusion, the writer is safe in saying, without successful contradiction, that no orchard should be cultivated continually for a period of five years without either an intercrop, companion crop, cover crop or a good application of barnyard manure.

INTERCROPS MADE TO PAY

In employing cover crops I have had two objects in view. First, to bring up the fertility of the soil, as I started with sagebrush land. Second, to decrease as far as possible the ultimate cost of the orchard when in full bearing. That I am accomplishing my purpose is attested by the fact that by the end of the third year from sagebrush three-fourths of the 40 acres I am caring for has been enriched either by a cover crop of clover or alfalfa or by a dressing of manure. Also,



Fig. 4. Fourth Year. This Orchard Has Had an Intererop from the Time it Was Planted.

the gross value of field crops f. o. b. Grandview for 1913 was approximately \$2,500 and of poultry and dairy products, \$1,000. Help during the year cost about \$500, leaving \$3,000, which met all current expenses of the ranch, including living expenses.

Crops grown in 1913 and comments on same follow:

Tree Fillers

I wished to put in some peach fillers, mostly cling, and some apple fillers, so adopted the hexagonal system of planting with permanent apple trees 33 feet apart and rows 28 feet apart with fillers in the same row as the permanent trees and 16½ feet from the permanent trees. No appreciable revenue has yet been obtained from the peaches, but a good crop is indicated this (fourth season) year with \$22.50 per ton offered by the Sunnyside cannery.

Hay

Leaving eight feet for the tree row, my planting plan permitted of 20-foot

strips of hay. A total acreage of 16 acres or a net acreage, excluding tree rows, of 11 acres, was in hay last year and yielded 45 tons, which was all fed on the ranch. Those portions of the ranch most heavily graded off were first seeded, using clover, as I expected to plow the sod up at the end of the second year. I am now making new seeding with alfalfa, as I expect to leave the ground in sod longer. I will state in this connection that clover is more of a surface feeder than alfalfa and seems to require more water to prevent robbing the trees of moisture. With care in watering and cultivating, I find no injurious results from stripping with grass but have seen many young orchards which have shown injury from seeding.

Cantaloupes

Six acres. Yield 1,150 crates. Returns f. o. b. Grandview \$1,350. This has been my best paying crop. Prices have been satisfactory three out of the last four years. The seeding and the harvesting

costs approximately \$60 per acre for a maximum crop of about 200 crates per acre and the cultivation and the watering incident to harvesting a good crop are ideal for securing a maximum growth on the trees. Cantaloupes do well on the heavier upland soils of the valley without fertilizer but do not appear to be adapted for the light sandy soils.

Potatoes

Four acres. Yield 28 tons, exclusive of culls—about two tons at \$3 or \$4 a ton fed to stock. Returns: One ton early potatoes, \$35; 22 $\frac{1}{2}$ tons, August digging, sold to net f. o. b. Grandview, \$395; three tons, late digging, \$45; total, \$440. I prefer early planting, as prices average fully as good, less water is required and the ground can be seeded in September to winter wheat for poultry. For potatoes and corn the ground needs enriching. Two years ago (1911) on ground not enriched, I harvested four tons merchantable potatoes per acre. Last year (1912) on manured ground the yield was seven tons, and this year I will have two-year clover sod with manure dressing, which I expect to yield around 12 tons per acre. All seed is treated with formaldehyde and so far I have had no loss from scab. On an eight to ten ton per acre crop, seeding and harvesting expenses need not exceed \$5 or \$6 per ton and fair returns are obtained at even \$12 to \$15 per ton for potatoes.

Corn

Five acres. Yield 175 bushels. Value, exclusive of fodder, \$125. This corn was on unenriched ground. Next year I will have two-year clover sod and expect better than twice this yield. I have been feeding the fodder to the cows but this year will put in a silo and corn not used for silage will be husked without cutting, the stocks run down with a stock cutter and plowed under. All corn is fed on the ranch, chiefly to poultry.

Wheat

One acre. Yield approximately four tons wheat, on straw. Value \$25. The wheat was sowed in September of the previous year, on land from which potatoes were harvested in August, and cut in

June and the ground replanted in July to rutabagas, making three crops in two years.

Rutabagas

One and one-fourth acres. Yield 175 sacks. Returns: 100 sacks shipped for culinary purposes to net f. o. b. Grandview about \$100; 20 sacks sold 50 cents per sack; balance fed to stock; total value about \$125.

Tomatoes

One-fifth acre. Yield two and one-half tons. Returns \$85. The tomatoes were packed in peach boxes and shipped. Returns varied from 30 cents to 65 cents per box f. o. b. Grandview. I was especially fortunate in my marketing but would not recommend a large acreage unless the greater part of the crop could be sold to a cannery.

Onions

One-tenth acre. Yield 12 sacks. Returns \$12. All things considered not a bad crop.

Black Caps

One-tenth acre. Yield 25 crates. Returns \$45. Considerable work in harvesting, but with pickers available a paying crop.

Poultry

While not a field crop the poultry and the cows are an important item on our ranch. The average number of hens was about 300. Total returns from eggs, sale of hens, broilers and about 25 turkeys, \$800. My experience would indicate about 50 per cent of the gross returns from the poultry to be required for feed. Considerable of the feed, including all excess milk from the cows, is produced on the ranch. The poultry have proved a valuable adjunct and personally more desirable than hogs. Our experience would indicate this valley to be especially well adapted for poultry.

Dairy

During 1913 we milked two cows, but have four heifers to freshen during 1914. The cream checks from the two cows after supplying the ranch with milk and butter amounted to about \$200. If the increase and growth of young stock, together with

the value of manure are included, the dairy showing is very gratifying.

F. A. NORTON,
Grandview, Wash

PRUNING

Pruning is plant surgery. It is the knife or instrument applied to a tree as the knife of the surgeon is applied to the body of the animal or of man. The consequences of error in the two kinds of surgery may be vastly different.

The life forces of the tree tend to restore the equilibrium that was impaired by the severing of the limb from the parent stock. It will likely put out new branches that perform, in a measure, the functions of the old, or increase the strength of existing branches, and this is an effort of nature to restore equilibrium of form and energy. Thus the consequences between the two kinds of surgery are different and yet analogous.

Have A Definite Plan

This leads us to conclude that no one should prune without a definite end in view. No one should go into an orchard and cut and slash promiscuously without reasons, any more than he would send a butcher into a hospital to carve the bodies of patients according to the rules he learned in the shop. No two patients in a hospital will need exactly the same treatment, unless in very exceptional cases where the circumstances are very similar and the organisms of the patients alike. In nature no two things are exactly alike, therefore, no two trees would demand exactly the same treatment in pruning. There are general characteristics, however, that belong to certain varieties, and these would lead us to give to each and every one of these varieties the same general treatment. For instance, the Wagener apple tree tends to grow straight, the branches closing in toward the center very much on the style of a Bartlett pear. There are other apples that tend to grow in the same manner. In trees of this character, the limbs would be cut away from the center with the purpose of giving a more spreading and open top than they would naturally have. The Jonathan, the Winesap, and other

varieties tend to produce bushy tops with spreading branches. Trees of this character should generally be pruned more from the outside in order to make it possible to cultivate, spray and gather the fruit with less interference from the overhanging branches.

Experience in Low Heading

There is one thing about which we are more fixed in our opinions than about any other on the subject of pruning, and that is the question of low heading as compared with high heading. We have been brought to this conclusion by one of those accidents which often cause us to discover things we would not otherwise discover, and therefore to reverse our judgments of methods. We have in our orchard several trees which, when they were young, were injured during the winter by rabbits. These orchard enemies peeled the bark from at least a dozen trees, and the owner of the orchard felt that great damage was done to them. The question was, whether to dig them up and plant others, or to allow them to grow and put out new shoots near the ground. The latter plan was adopted. These trees are now sixteen years old, the same age as other trees in the orchard, and of those adjacent to them. We have taken photographs of these trees in comparison with others of the same age and the same varieties near them, and the photographs show what is true in fact, that in every case the trees that were headed at the ground or just above the ground, are the largest, most vigorous trees in the orchard. The same conditions prevailed in the case of the high headed trees as in the case of the low, except that in the case of the low headed trees the branches put out just above the ground, while the others were headed so that they began to branch about two feet above the ground. Whatever may be the causes the facts remain. We have seen this in other orchards as well as in our own. When we try to discover the causes we find the following:

1. There is less space between the root system and the top system, and there is,



Fig. 1. Arkansas Black Orchard of W. N. Yost, Meridian, Idaho, showing low-headed trees of unusual vigor. Trees 18 years old.

therefore, less exposed surface that is subject to disease, injuries by accident, etc.

2. There is less energy required to carry food from the root system to the top and from the top system to the root, and as the railroad man would say, there is less expense and less friction in the shorter haul. The trunk of a tree is a circulatory system, a kind of common carrier that exchanges the products of one part of the tree for the products of another.

3. There is no extra sap required for the support of a longer body, and therefore the extra energy that would be required to support the extra length of body goes into the branches.

4. It is easier to pick the fruit from a tree with a low top than from one that is higher in the air. It is easier to prune and to spray. When the fruit falls from the top of a low tree it is less likely to damage and bruise in falling, and therefore there is less waste. Our observations lead us to the conclusion that the trees are almost always healthier, and

this is shown in the fact that they grow more vigorously and produce more fruit.

5. There is another reason in favor of low heading that is worthy of consideration, and that is, that trees are bent by force of the wind currents and the taller trees bend more than the lower ones. Often great damage is done in this way, especially to trees that are heavily loaded with fruit so that the center of gravity is beyond the base. Trees are sometimes broken in this way. Much less damage is done from this cause to trees with low tops.

There are advantages on the other side, for experience teaches us that it is more difficult to cultivate among trees that have been headed low, but this can be largely obviated if care is taken in shaping the tops and in the choice of tools for cultivation. In orchards that have been pruned with this in mind, it is about as easy to cultivate around trees that are headed just above the ground as around others that are headed eighteen inches higher.

Of course there is a difference in the



Fig. 2. Orchard near Kennewick, Wash. Peaches in the Foreground. In windy sections trees do much better if headed close to the ground.

pruning of apples, peaches and pears, because these trees are by nature differently formed, but with these differences in mind we give a few general rules. It is understood that these rules are made to be followed when they seem best adapted to the circumstances, but made to be broken when the nature of the conditions seem to require.

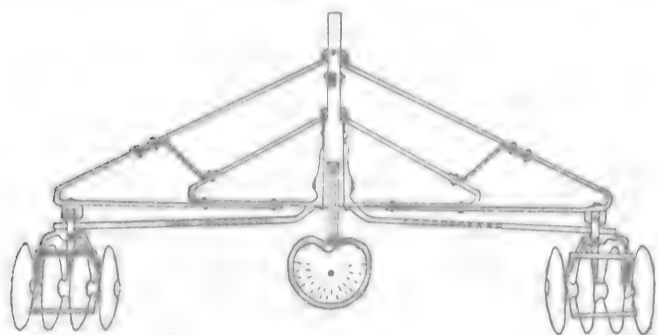

Fig. 3. A Convenient Disc Cultivator, capable of being extended for cultivation under low trees.

Rules for Pruning

First. We remove certain branches in order that the plant food gathered by the roots may be used to support the remaining branches and stimulate more vigorous growth. If the tree is not growing rapidly enough, this is very important,

but on a tree where there is a heavy wood growth this is not needed and may be an injury in preventing the forming of fruit spurs.

Second. We remove a branch when it interferes with the growth of another that we consider of greater importance than the branch to be removed.

Third. We remove a branch when it grows in a direction to give the tree an undesirable shape. Usually in the Northwest we prefer the open top and spreading branches in order to let in the sunshine to color the fruit.

Fourth. We remove a branch when its weight tends to pull the top in an unde-

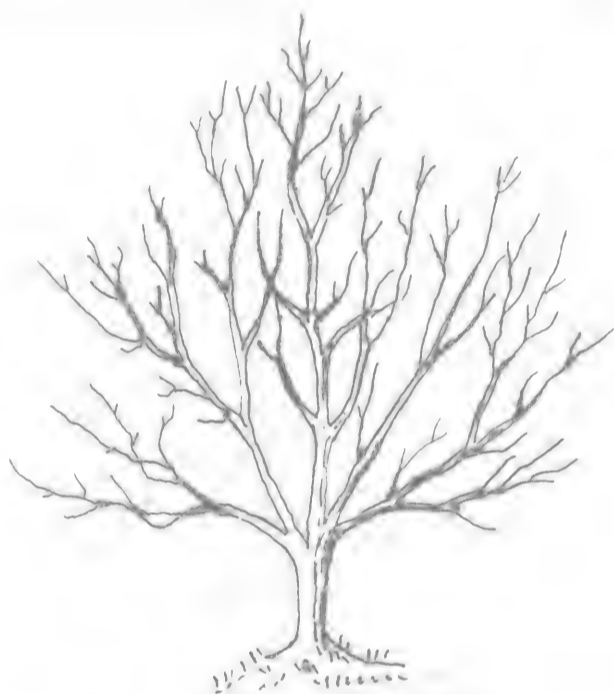

Fig. 5. A Well Shaped Tree.

—After Brackett

sirable direction. The heaviest and longest branches should be left on the side of the tree from which come the prevailing winds. If this is not done, the tree will lean, and when it is heavily loaded with fruit the average weight will be far enough from the center to uproot it or break it, or in some other way injure it.

Fifth. We remove a branch when it is diseased. We do this not only because it is useless, but because the diseased part may also injure the healthy parts.

Sixth. Summer pruning is resorted to, generally, in order to produce fruit spurs. In young trees from one to five years of age summer pruning is a method of causing the trees to put out extra branches



Fig. 4. A Beautiful Illustration of Symmetry and Regularity in an Orchard. Seen from a distance the tops of these trees are as level as the pruning line seen in the picture. However, the trees are headed too high both for the vigor of the trees and for convenience and economy in spraying and in harvesting the crop.



Fig. 6. Sixteen-year-old Gano. Headed Near the Ground. Circumference at Base, 46 Inches.



Fig. 7. Sixteen-year-old Gano. Headed 24 Inches from the Ground. Circumference at Base, 40 Inches. Trees on the Left Headed at the Ground. (See Fig. 12.)

that mature their wood sufficiently so that they are not in general killed by the winter freezing. These branches are started for the growth of the coming season and the sap which would go to promote the growth of longer shoots that would be cut off the following spring is thrown into the new branches, many of which will be left the next year, and in this manner three years of wood growth, it is believed, can be obtained in two years of this kind of pruning.

At this point, however, there is some controversy and the theory is not universally accepted.

Seventh. When a tree is being transplanted the tops should be cut back at least far enough to correspond with the root pruning necessary in removing from the nursery and setting in the orchard. In the dry climates this cannot be too strongly emphasized, because the dry air tends to rapidly absorb the sap from the young leaves and branches and if there is too much top surface exposed to the dry atmosphere it draws too heavily on the root system which has not yet sufficiently thrown out tender rootlets to absorb sufficient food and moisture.

Eighth. Branches are removed when they are so low as to interfere with proper cultivation.

Ninth. Branches are removed when they are so high that it is inconvenient to pick the fruit.

Tenth. Heavy pruning is often resorted to when trees are planted so close together that their branches interfere with each other.

Eleventh. The proper time for winter pruning is during the dormant period, somewhere between the dropping of the leaves in the early winter and before the opening of spring. It is not well to prune when the wood is frozen, as that seems to injure the tree. The time for summer pruning depends a good deal on the latitude. In most countries where apples are grown perhaps about the first of July would be the preferable time.

Twelfth. Trees that tend to head inward, or toward the center, should have

the intertwining branches cut away to give them a more spreading top.

Thirteenth. Trees that tend naturally to produce overhanging boughs or spreading tops should be pruned from the outside more than from the inside.

Fourteenth. In pruning, care should be observed in distinguishing between fruit spurs and small limbs that protrude from the branches. In cutting away fruit spurs we destroy the possibility of producing fruit.

A summary of these rules would be about as follows:

Remove branches to invigorate other branches; remove branches that interfere with the growth of more important branches; remove branches that give the tree an undesirable shape, remove branches that pull the top in the wrong direction; remove branches that are diseased; remove enough of the top to correspond with the root; remove branches that interfere with cultivation, remove branches that are too high for the convenient gathering of fruit; prune any time when the tree is dormant and the wood is not frozen; do not cut away the fruit spurs.

Photographs of Trees Headed Both High and Low

In the orchard of the Editor, North Yakima, Washington, were a number of trees, to which we have referred, which, when young, were damaged by rabbits. The owner at that time had to decide between cutting them off at or near the ground or digging them up in order to plant new trees. He decided to cut them off. The trees are now sixteen years old. On April 4, 1912, photographs were taken and measurements made in order to determine the comparative size of these trees with others in the same row, same varieties, same age, and the same conditions as nearly as two trees growing twenty feet apart can be said to grow under the same conditions. We might have selected a number of other trees that would give about the same results, but these were believed to be sufficient to illustrate the facts and principles involved.



Fig. 8. Newtown Spitzenburg, 16 Years Old. Headed at the Ground. Circumference at Base, 43 Inches.



Fig. 9. Newtown Spitzenburg, 16 Years Old. Headed 35 Inches High. Circumference at Base, 25½ Inches.

Figures 6 and 7 are Ganoes, and the measurements are as follows:

Fig. 6 headed near the ground, measured in circumference at the base 46 inches.

Fig. 7 headed 24 inches high, circumference at base, 40 inches.

Fig. 8 headed at the ground, Newtown Spitzenburg, 43 inches.

Fig. 9 same variety, headed 35 inches high, 25½ inches circumference.

Fig. 11 Esopus Spitzenburg, headed 16 inches high, 41 inches in circumference.

Fig. 12 Esopus Spitzenburg, headed at the ground, see Fig. 7.

In every case the top system of the low headed tree was stronger, healthier and larger. No records have been kept of the bearing, but from memory would say that the fruit yielded is in proportion to the size of the tree.

The accompanying cut is used to represent a wrong method of pruning.

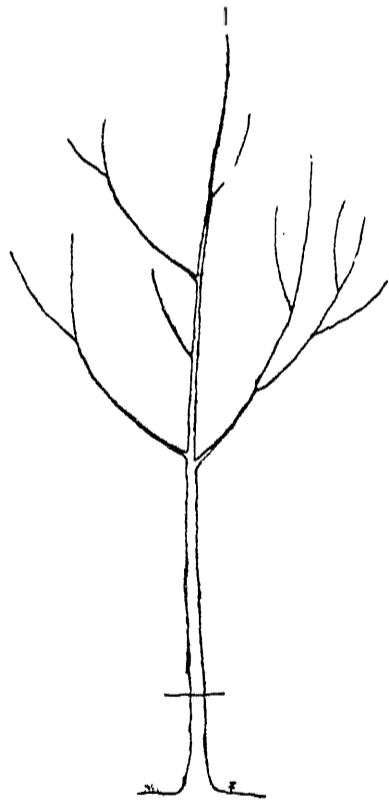

Fig. 10. Pen sketch of frame work of four year old tree which bore 41 apples.

According to our belief, the top should have been started at cross mark, rather than thrice that height, because it could have born its fruit with less than half the strain and would have been less likely to lean or break by the force of the winds.

However, in traveling over the country,

we have discovered that all conditions are not the same, in fact, no two places are exactly alike in climate, soil, or other environments, and that what might be better under one set of circumstances would not be wise under vastly different conditions. For instance, in Eastern Colorado and Western Kansas, where the winds are strong and the sun hot, it is better to head the trees at the ground to prevent leaning, breaking and sun scald. In the coves of the hills or mountains, where the trees are protected from the winds, there would be little danger of injury from winds and in a humid climate little danger from sun scald. We give, therefore, views from several authors with wide experience in several states. These views differ in many particulars but are doubtless the results of experience in the various sections from which they come.

GRANVILLE LOWTHER

Pruning When Transplanting

We are ready to set the tree and the problem of pruning is before us. It is necessary to cut away part of the branches to enable the injured root system to supply the remaining branches with water. The less the roots are injured the less the top need be cut away. Both theory and experience lead to the belief that fruit growers usually make a mistake in the manner of pruning newly set trees. The common way is to cut back all of the branches. This, in many cases, is wrong. The top buds on a branch develop soonest and produce the largest leaves. Now a newly-set tree will grow best if it can develop a large leaf surface before dry, hot weather sets in, and this it will do if some branches are left intact. Therefore, instead of shortening-in all branches, cut away some or the branches entirely. The tree so pruned will start growth and acquire vigor more quickly and a better top can be formed. There are some cases in which certain fruits or varieties produce abnormally long branches by the end of the second year which may have to be cut back.

At the end of the second year the root system will have a good start and if the whole



Fig. 11. Esopus Spitzenburg, 16 Years Old. Headed 16 Inches High. Circumference at Base, 41 Inches.



Fig. 12. Esopus Spitzenburg. 16 Years Old. Headed at the Ground.

top is at that time cut to within a few inches of the ground, the tree will send forth vigorous branches that will in two or three years form a head equal to the first and ever after be a more vigorous tree.—Ed.

The Height of the Head

A decisive choice must be made at the very start as to the height of the head. Shall the tree be low or high-headed? The choice should usually be for a low-headed tree for the reason that such a tree is more easily sprayed and pruned and the fruit more readily thinned and harvested; crop and tree are less liable to injury by wind; the trunk is less liable to injury by sun scald, winter-killing and parasites; the top is more quickly formed and the low-headed tree soonest bears fruit. No advantage as to cultivation is gained by either method over the other, as a well trained tree with a low head, in which the branches ascend obliquely, permits the cultivator to come sufficiently near the tree. It is a fact, for which no explanation can be offered here, that the branches of low-headed trees ascend more uprightly than those of trees headed high. By low-headed is meant a distance from earth to first limb of from one to two feet. The peach may be headed at the lower distance, the plum, pear and cherry somewhat higher, while the apple should approach the upper limit.*

U. P. HEDRICK,
Geneva, N. Y.

Pruning One-year-old Trees

With a one-year-old tree pruning is easy. Remove the branches and cut back the remaining whip to the heading height desired. The reason for this cutting back is that a tree of this age has not sufficient space of bare trunk between branches for final branch spacing. If the tree is two years old as is usually the case with all fruits excepting the peach or when the one-year-old plants have been set a year, the real work of heading may be begun, but even now the required space for proper heading hardly exists, and the head cannot yet be wholly formed. This early pruning is, therefore, all more or less provisional though an ideal for the future

* Our opinion is that the lower limit is better than the upper.—Ed.

tree must be plainly in the mind from the start.

Pruning for Wood

When the head of the tree is formed subsequent pruning is directed toward the formation of wood or of fruit-buds. If a tree is bearing many small fruits, if the top contains dead or dying branches, or if the seasonal growth is short and scant, it may be taken for granted that the tree lacks vigor, or, in old trees, is passing into decrepitude. Such trees may usually be rejuvenated by judicious pruning. In professional terms the tree must be "pruned for wood." Such pruning consists in cutting back a considerable number of branches and in wholly removing others. The practice is based upon the fact that the development of the leaves and shoots—vegetative activity—is dependent upon a constant supply of the soluble nutriment—the sap. Therefore, when the size of the tree top is diminished the remaining parts grow more lustily. If half of the top of a decrepit tree is cut away, the remaining half in the season that follows will produce a leaf surface often twice that which the whole top would have borne. When trees are enfeebled by age, injured by insects or fungi, robbed of food and moisture by sod or crops, or neglected in any way, there is nothing which will more quickly stimulate them and renew their youthful vigor than conservative surgery. Such pruning for wood should usually be extended over two or more years. In pruning for wood the following rules are usually applicable:

Weak-growing varieties may always be pruned generously; strong-growing kinds lightly.

Varieties which branch freely need little pruning. Those having unbranching limbs should be pruned closely.

In cool, damp climates trees run to wood and need little pruning. In hot, dry climates they need much pruning.

Rich, deep soils favor growth; prune trees in such soils lightly. In shallow, sandy soils, trees produce short shoots, and the wood should be closely cut.

The Form of the Top

Two general types of top are open to choice; the vase form or open-centered

tree, and the globe or close centered tree. In the first the frame-work of the tree consists of a short trunk surmounted by four or five main branches ascending obliquely. In the close-centered tree the trunk is continued above the branches, forming the center of the tree. There are several modifications of each of these. In this climate the open-headed, vase-formed tree is best for the peach and the close-centered two-storied tree is best for all other fruits. Whatever the form, care should be taken that the lowest branches are longest so that the greatest possible leaf-surface will be exposed to the sun and light.

Tree Formation

For several years after planting, the peach alone excepted, fruit trees need to be pruned only to train the tree. Just how much to prune young trees depends upon the fruit, the variety, the soil and the climate. Fruit growers prune trees far too much, thereby increasing the growth of wood and of leaf surface and of delaying the fruiting of the plant. If trees were originally well selected all that is needed is to remove an occasional branch which starts out in the wrong place—the sooner done the better—and to take out dead, injured or crossed limbs. The peach, some plums and some pears may need heading-in, and a weak or sickly tree may require somewhat more severe pruning.

Dehorning Trees

A great deal is said about dehorning trees. By dehorning is meant the cutting back of all branches to within two feet or even less of the trunk. The term in use for this rather severe operation is a misnomer, for the tree so treated is really decapitated. If cutting off the top of a tree is "dehorning" one can as well say that cutting off the roots is "detailing." Most trees that are "dehorned" may as well be "detailed" at the same time. There are, however, exceptional cases with peaches and possibly other stone fruits when this wholesale renewing of top is rational, as when good trees of these fruits in their prime are severely injured by overbearing, heavy

winds, snows, fungi, or other causes. But to "dehorn" peach trees 15 or more years old for the sake of one more crop is usually a very poor practice. Such trees in most cases should go to the brush heap and a young orchard take the place of the old.

Root Pruning

Root pruning is seldom necessary in American orcharding. In cooler, damper climates it is of some value in dwarfing trees and in bringing them into fruit. To prune the roots is to cut off the food supply and thereby starve the tree. This drastic treatment is sometimes recommended for the orchards of this region but it is extremely doubtful if properly pruning the top, good tillage or less severe measures than cutting the roots will not bring about the same results without permanently weakening the trees as does root pruning. This applies to pruning the roots of mature trees and not to the fantastic notion set forth by Stringfellow 10 or 12 years ago that young trees are best transplanted by cutting the roots back to a stub. Until nature reverses the laws of plant-growth, tree planters had much better continue setting trees with a root system ready to perform its function naturally and normally even though a plant pruned to a stub may grow, and under exceptional conditions may grow well.

The Work of Pruning

Each man must select his own pruning paraphernalia—as ladders, knives, saws and shears. Occasionally you see a man pruning with an ax. Now an ax is a good tool for some purposes but it is not of much value in pruning. A sharp knife in the hands of an expert is a better tool than shears, but the amateur had much better stick to shears.

The cut in pruning should always be made parallel with the trunk and as close as possible. One of the most elementary rules of pruning is that the cut should be made just beyond a healthy lateral branch, and yet in the average orchard the rule is violated more often than it is followed. The reason for so cutting is plain. The lateral branch is stimu-

lated to produce a great number of leaves which assimilate sap. This elaborated food passes back through the inner bark near the newly made cut and the wound quickly callouses and heals because it thus has access to an abundant supply of food.

The notion prevails that a wound of any size will heal, but the majority of wounds over three inches in diameter do not heal—decay sets in, followed by wood-destroying fungi, and these, with the action of the weather, are followed by rotten wood, a hollow branch and a diseased tree. The Geneva station is now digging out an apple orchard in which the centers of the trees were removed some 15 or 18 years ago. The trees might have borne crops for two or three decades longer but practically all are worthless from the results of the cutting out of large limbs. The life of a tree is endangered whenever a large branch is removed, and such an amputation should be made only under dire necessity. Tree lovers shudder at the ghastly wounds and mutilated trees in the average orchard. The professional "hewers of wood" who call themselves "tree pruners" are responsible for much of the dreadful slaughter seen in orchards.

It is presumed that every fruit-grower has learned from observation or experience that one of the secrets of the healing of large wounds is to cut close to the trunk, and no matter how large a wound may be it is better than leaving a projecting stub. The chances for healing with a large wound are materially increased by a coating of thick lead paint to protect the cut surface from evaporation and moisture. It is a waste of time to treat wounds less than two inches in diameter.

U. P. HEDRICK,
Geneva, N. Y.

One Spring and Two Summer Prunings

The accompanying photographs illustrate a method of pruning employed by an orchard company near North Yakima, Washington.

The method consists of pruning young trees once before the buds put out in the spring, once about the last of May or



Fig. 1. Tree One and One-Half Years After Removing from the Nursery. The photograph was taken about the first of September, the second year of growth in the orchard. The tree was pruned early in March, early in June, and was photographed just before pruning early in September of the same year.



Fig. 2. The Same Tree After the Second Summer Pruning, September 1st.

first of June, and again about the last of August or first of September.

The trees are well watered and manured and make a rapid growth.



Fig. 3. Another Tree Grown and Pruned in a Manner Similar to That Already Described.



Fig. 4. Represents the Same Tree After Pruning. Photos Courtesy Yakima Orchard Securities Co.

The Natural Method

Pruning is as natural and as old as any other orchard operation. Nature has always adopted this method for reducing the exceedingly large number of buds and small sprouts from growing into large branches and thereby over-taxing the energies of the tree. She not only prunes regularly and at the right time but she prunes without leaving large and ugly scars on the tree. We should try to copy after nature by doing the work at the proper time and in that way will not only remove the small branches but keep the tree in shape throughout. It is quite common to wait until undesirable habits of growth have established themselves and then begin a general thinning out and shaping of the tree. The effect of this kind of pruning generally results in some kind of injury to the plant.

It is a very hard matter to give definite instructions about how to prune trees since there are no two trees that are exactly alike. No two trees can be pruned alike if they are pruned properly. "Pruning is a matter of judgment, not a rule." No one can tell you how to prune your trees without seeing them. While this is true there are a few principles which may apply everywhere and if the fruit grower follows them he ought to avoid making many mistakes in pruning. The best rule is to prune regularly and at the proper time. If the tree is neglected for a few years and then severely pruned it is likely to make a very vigorous growth of wood in order to restore the balance which the pruner has upset. If the tree is cut back severely the roots immediately endeavor to restore the equilibrium by producing a vigorous top growth or heavy growth of suckers or sprouts. This is likely to cause a reduction of fruit. Sometimes trees which produce a large growth are shy bearers. It is better to prune a little every year and not a large amount every three or four years. If trees are growing too fast the worst thing that can be done is to remove a large amount of wood during the winter. That only stimulates the tree to grow that much faster. If the desire is to check the growth it can

be done better by withholding cultivation and irrigation or by what is termed summer pruning. Top pruning produces wood while root pruning reduces wood. Checking growth induces fruitfulness. The season of pruning influences fruitfulness and for that reason it is better to summer prune for fruit and winter prune for wood. Climate and locality may affect the time of pruning.

Young trees grow rapidly and make strong, upright growth, but as they get



Fig. 1. Improper Method of Cutting the Limbs.

older and come into bearing the tops spread out and the growth is less vigorous. Bearing trees require less top pruning, and this seems to be especially true in a dry climate.

Every apple grower is confronted every winter with the question of how best to prune his trees. The heaviest pruning in proportion to the amount of tree top should be done during the first three to five years of the tree's growth. During this time the apple tree should be properly started and be well pruned so that when it comes into bearing it will not be necessary to prune it severely.

Two forms are generally considered in the starting of the young apple tree in the orchard, the low and high-headed tree. The choice of either one of these forms depends to a great extent on the cultural methods to be followed by the orchardist, and upon the climatic conditions. The high-headed tree is better

adapted to Eastern sections while the low headed trees are preferred for New Mexico.

The first pruning of the young apple tree, after it has been transplanted to the apple orchard, should be carefully done as at this time we determine the height of the trunk. The top should be cut back to about 12 to 18 inches from the ground. The following spring a number of limbs will develop from the trunk. Three to five limbs should only be allowed to form the scaffold. At the next pruning, the following spring, these scaffold limbs are again cut back somewhat and any interfering limbs are also removed. At the third and even the fourth pruning the limbs should be cut back and the tree rounded up generally. By this method of pruning the tree is shaped up and properly started.

While there are some fruit growers who claim that the bearing apple tree should be cut back every year the nature of the growth in this climate does not warrant such practice and on the whole the results are not so satisfactory. The bearing tree should be pruned as lightly as possible. It does not produce the same rank growth that the young tree does during the first few years. A great deal of the vitality of the bearing tree is used up in the production of the fruit, and in fruit spurs for the following crop, as it takes two seasons for the apple to form its first buds. While the tree does not require severe pruning it should be pruned a little every year. All the dead and broken limbs should be removed as well as those which interfere. Avoid the cutting of large branches.

The limbs should be cut as near the trunk as possible so the wound may heal over quickly. Never cut limbs so as to leave a stump one or more inches in length. Such stumps if left never heal over. The healing of the wound depends on the activity of the cambium layer. This layer is most active in the spring after the tree starts to growing. The longer the wound remains exposed the more it will dry and crack. Wounds which are made in the fall or mid-winter necessarily remain longer before the cam-



Fig. 2. The Cambium Growing Over a Properly Made Wound.

bium layer begins to grow over them than those made in the spring just before the tree starts to growing. While trees can and may be pruned any time during their dormant period—that is during the fall, winter and spring—the preferable time is in the spring, shortly before growth begins.

FABIAN GARCIA,
Santa Fe, N. M.

A Vermont Viewpoint

The successful growth of a vigorous and well developed tree is largely dependent upon rational methods of pruning. The pruning a tree receives during its first few years determines the shape of its mature head. The young tree at the time of setting should be severely pruned. As a rule the roots are cut back to six or eight inches and the top either to a whip, or, if it has been started at the right height in the nursery, from three to five of the best placed branches are selected for the scaffold limbs or framework of the head and these are cut back to correspond with the roots. Fall planted trees should not be pruned back as severely, since the wood

is likely to suffer from drying out and winter freezing. Frequently when the top is light, pruning is deferred until spring, when practically the same cutting back is given as to the spring set trees. When the trees are pruned to a whip it is for the purpose of establishing a lower head or for securing better placed scaffold limbs. The limbs left for the framework of the tree should not be located opposite to each other as limbs thus placed would have a tendency to form a weak crotch.

The advocates of the low headed apple tree seem to be in the ascendancy over those who prefer the high head. This type of tree is called for because of the necessity of fighting insect and fungus pests. The lower and more compact tree top makes spraying a much easier and simpler process, reduces the number of windfalls, and lessens the cost of harvesting. A low head might be defined as from 15 to 24 inches, and a medium head from 24 to 42 inches, while anything above 42 inches should be termed a high head.

WILLIAM STUART,
Burlington, Vt.

Experiments in Arkansas

Experiments in pruning at the Arkansas station from 1902 to 1906, on various varieties, including Ben Davis, and its descendants, at various seasons of the year, as well as the work in the large orchard last year, show that whether pruning is injurious depends on the manner in which it is done rather than upon the season or size of the limb.

The work was undertaken simply on account of the fear many have of serious consequences following the removal of limbs in this climate. One of the first opinions the writer heard in Arkansas respecting the management of orchards was from an old gentleman who said: "One thing certain, make a note of it, you've got to keep the knife away from trees down here, especially Ben Davis. I have seen more trouble down here from pruning than from all the other bad orchard practices combined. Trees won't stand pruning down here. It is a different climate from up North; and I have seen more than one northern man come down here

and ruin a good orchard by not taking that into account." This opinion, which is more or less prevalent, I have found to be absolutely without foundation as far as the simple removal of limbs is concerned. The opinion originated not in the practice, however, so much as in its abuse. To hack off limbs roughly, with a hatchet, and to attempt by means of hatchet or axe to convert low-headed trees into high-headed trees, is a sure means of producing disastrous results. Orchards are frequently seen where such pruning has wrought sad havoc with otherwise good trees. Orchards have often been killed in this way. The mischief was in ignorance, not in pruning.

Limbs of almost any size may be removed if the work is done right, while the removal of a branch one-half inch in diameter may result in injury if it is done badly. There is unquestionably a greater necessity for care and correct pruning here than in some other sections. There is more of a tendency of the bark to dry and die back in the case of stubs, and careless pruning, but if the work be done correctly pruning may be done here without any danger whatever, the same as in other sections of the country. Bad pruning is more common than correct pruning. Hence the origin of the present ideas concerning pruning, and the common neglect of this useful practice.

Lately, in riding along the country road, the writer has seen several instances of "villainous work" in orchards, which the owner intended for pruning. Fresh stubs, varying in size from an inch to three inches in diameter, and as much as eight inches long, were visible in abundance from the road. Sometimes a good pruner, or the owner takes this method of marking limbs which he wants removed, leaving the stubs to be sawed off, by a cheaper man. I found myself hoping that this was the design in this instance, but from what I observed in many other instances, I fear I was indulging a vain hope.

Early training of the top is frequently wholly neglected. The result is the production of unbalanced heads, limbs in

the wrong place, and the necessity for the removal of large limbs later when there is a likelihood of damage from sunscalding to portions of limbs, and decay in wounds. Attention to forming the head and keeping out unnecessary growth would conserve the energies of the tree, and remove the necessity of severe pruning so often considered necessary later. The nurseryman is concerned only in growing trees. His idea is not the orchard, but a salable tree, and as many as he can grow on a given area. He usually plants closely and the head formed is often high and poorly balanced. The orchardist should not depend on the nurseryman's head in either sense. In this climate low heads, say started about three feet from the ground, are desirable. The interference with subsequent cultivation must be overcome by the use of suitable orchard implements. In shaping the young two-year tree the main stem or a strong branch, should be left for a leader. The side branches should be cut back to within a few inches of the main stem, leaving buds near the ends of the stubs on the side toward the gap which it is desired to fill by the growth to be made. About the second year from this trimming the leader may be cut back to induce branching; the idea being to distribute what is to become a skeleton of the tree over about three feet. One of the more upright top branches should again be selected for a leader to continue the center of the tree upwards, and it is always desirable to maintain this plan throughout the life of the tree. In the case of young trees, removing a branch to the base leaves a gap on that side of the tree. Cutting back to a stub is done largely in proportion to the strength of the branch and may be used for filling gaps. Strong branches may be left longer; weaker ones must be cut back closer, or to two, three, or four buds.

Very great damage to trees is frequently the result of bad, careless and untimely pruning. Many of the trees which have died the past season (1906), and having the appearance of trees killed by root-rot, were dead as a result of fungus diseases following the removal of limbs

broken by overbearing or for other reasons.

The opening up of a head of a tree which has been allowed to become crowded, is very apt to be followed by sunscalding on portions of limbs previously shaded. This is serious in itself, and suggests that the best pruning is that which is avoided by careful attention to disbudding, the removal of limbs when they can be rubbed off or cut out with a pocket knife, and so training the head at the start that the removal of large limbs on bearing trees will be unnecessary. Pruning should be directive rather than corrective. The grower should have a distinct ideal in his mind at the start of what form of top he desires, and that ideal should be based on the necessities of the climate and the experience of successful local orchardists, or on experimental studies. One from another locality, who purchases an orchard in a region where conditions are new, should not hastily undertake the remodeling of the orchard to conform to ideals of the region from which he came. When the removal of large limbs is unavoidable, or desirable; then it should be done in the best manner and at a time when the risk of

subsequent mischief will be the least. Many of our growers select the season when the trees are just starting into growth, continuing the work till June. I believe a more favorable time for the work would be January and February.

I have seen trees pruned in April with no serious results. The cuts were made right, and scars one and one-half inches were almost half covered in a year. These trees were growing in good soil and were in a very vigorous condition.

Again I have seen severe bleeding follow June pruning of the Ben Davis. These were bearing trees. Limbs in the same orchard cut earlier were not followed by this effect. In both cases, however, stumps were left from three-quarters inch to one and one-half inches long. This may have been partially responsible for the bad effects in the latter pruning.

In another large orchard examined where the practice is to do the pruning in January and February, and cut the limbs close to the parent branch, evil consequences following pruning are unknown, and wounds heal over nicely in a year or two.

Pruning earlier in the season does not remove all possibility of injury, but ob-



Fig. 1. A and B Indicate Improper Cuts. White lines show where cuts should have been made. C shows properly made cut which has healed over.—Purdue Station.

viously is attended with less risk. A very common practice is to leave more or less of a stub in the removal of limbs. This is a source of serious mischief. Such wounds cannot heal over. They are off the channels of cambial activity, and the edges of the bark die, the end dries and begins to decay. Fungi find lodgment, and soon decay proceeds downward to the main branch, or else the fungi starting in the bark soon spread to the main limb, girdling it, and causing the death of large limbs, sometimes the whole side of a tree, and even the entire top. Instances of all these results are extremely common.

Whatever season is preferred by the operator, limbs should be cut off closely and parallel to the general direction of the parent branch. In the removal of limbs a sharp well-set saw, giving a smooth, clean cut, is as good an instrument as can be found. The rough work of the hatchet, or axe, is as much out of place in an orchard as in surgery. The rough wounds have a tendency to retain particles of dust and moisture, offering bacteria and the spores of fungi a very favorable place for starting into activity. Bruising and tearing of the bark about the edges of the wounds is also very serious. The smoother the cut the better. In sawing off large limbs the cut should be started on the under side. Wounds should be coated over in two or three days after being made, with an adhesive waterproof antiseptic coat. White lead mixed with linseed oil is one that the writer prefers. Boiled coal tar is also satisfactory. Especial attention should be given to coating the entire wound. The lower edge is the weakest point about the wound on account of being the last to dry off after rains. Another coat later is very desirable.

ERNEST WALKER,
Fayetteville, Ark

Pruning from Connecticut Viewpoint

Regarding this subject there exists a great difference of opinion, both among fruit growers and official horticulturists. The conflicting recommendations of the various authorities are due partly to the varying conditions under which apples are

grown, but more particularly to our meager stock of experimental evidence relating to the subject. On traveling through New England one becomes impressed with the great variety of tree structures. Some trees have large broad heads with open centers and some are so crowded that their heads have not had a chance to expand. Some are low headed, some high headed, and some have been beheaded. Others have been pruned from beneath as high as a man can reach with an axe and others, by far the largest number, seem never to have been pruned at all.

With so many conflicting opinions as to how a tree should be pruned, it seems necessary that the fruit grower should settle upon some form of tree structure, and, starting with the young tree, develop his ideal. Varieties and individuals differ greatly in form and habit, but even in the most stubborn cases it is possible to approach the ideal. Each tree must be pruned with respect to its own individuality. A tree that is making a strong growth should have a different treatment from one making a weak growth, and a tree with an upward tendency demands different training from one with a spreading habit. Pruning should be regarded as a work of training rather than of correcting. In the treatment of neglected trees it is necessarily a work of correction, and it requires several years of this work to make up for the lack of training.

The Low Headed Trees

The general tendency at the present time is to grow low headed trees and the number of advocates of the high headed structure is becoming smaller every year. The necessity for thorough spraying since the advent of the San Jose scale has done much to bring about this change of ideals. Low headed trees are not only more easily sprayed but they can be pruned more conveniently and the fruit can be more economically thinned and harvested. It is difficult to estimate the difference in the cost of harvesting fruit from high and low headed trees, but it is probable that there would be a difference of at least 25 per cent in favor of the latter. Low headed trees are less susceptible to injury from

winds and their trunks are not so likely to be affected by "sun scald."

The best time to settle this question is at the time of selecting the nursery stock. Much may be done, however, in the way of severe heading-in. Many trees that were originally low headed have become high headed owing to the close planting and crowding. The only treatment for such a condition is to cut out half of the trees and "dehorn" the remaining ones.

Some varieties, like Sutton and Yellow Transparent, are naturally upright growers and are kept down only by very careful and persistent treatment. In the first place the trees of such varieties cannot be headed too low. The branches should be started at, or very near, the surface of the ground. Much may be done during the first few years by careful training, cutting back the successive annual growths to about one-third of their length and always cutting back to a bud or branch pointing outward or downward. The greatest progress will be made after the trees commence to bear, for at this time the weight of a crop tends to bring the branches down. The important point, therefore, is to induce fruit-bearing as early as possible. Summer pruning, as described under another head, is probably the most effective way of inducing fruitfulness.

The Open Center

We hear a great deal these days about the tree with the open center. The object of the open center in apple trees is to admit more sunlight and in this way produce more highly-colored fruit. Inasmuch as the greater part of the fruit is borne on the surface of the tree, the important point is to develop as far as possible a tree with the maximum surface exposed to the light. A tree with a broad cone-shaped top probably gives the greatest exposed area, and this is in opposition to the open center idea. While opening up the center will likely give additional color to a few apples in the center of the tree and will admit of a better circulation of air, it is a question whether it would not be better to open the tree moderately on all sides. If it is good to open up the top, the same should apply to any portion

of the tree. In sections where trees are likely to "scald" the open center exposes the branches to the direct rays of the sun, and for this reason is objectionable. While the writer does not approve of open center methods as practiced by the extremist, he favors the removal of the high central leader usually found in neglected trees. In such cases the new growth soon fills up the space and protects the exposed branches from the sun.

Which Branches Should Be Removed

The inexperienced pruner will have trouble in deciding which branches should be cut out and which should be left. Any one may become proficient in the work if he will study the effects of different kinds of treatment. The most common error is in leaving too much brush on the tree. A tree in winter may seem to be well opened up, but will often appear very different when the tree is in foliage, and the operator should keep this constantly in mind. Removing brush from a tree may greatly reduce the number of apples without reducing the yield. In this respect pruning is a thinning process. Trees that are bearing regularly and that are not being over nourished will not require much pruning. This is one reason—and there are many others—why an even growth should be maintained. The branches to be removed are mainly those that interfere with other branches. It should be the aim to have an even distribution of branches with abundant space between them for the free circulation of air. In selecting between two branches that interfere with one another the most desirable one should be retained, keeping in mind convenience in spraying, harvesting, and the other operations. Other things being equal, the lower one usually should be retained. Besides relieving the crowding, all objectionable cross branches in the center of the tree and all dead and diseased branches should be removed. The rapidly growing shoots, especially at the top of the tree, should be cut back with a view of maintaining a symmetrical structure. Water-sprouts around the base of the tree should be removed. Those found on the main branches should



Fig. 1. In heading back upright branches, the cut should be made just beyond a branch extending outward, as shown in this picture. The fruit spurs along the main branches should not be removed as has been done in this case.

either be removed or cut back. By pinching back these shoots in early June, they often may be converted into fruit spurs. The fruit spurs along the main branches should not be removed, as is so often done. Some growers do not believe a tree is properly pruned unless the main arms are as bare as telephone poles. Many growers make the serious mistake also of cutting off the lower branches because they interfere with the work of cultivation. These are often the most profitable branches on the tree, for the reason that the fruit they bear can be so quickly and conveniently harvested.

Making the Cut

Much may be done in the way of directing the growth of the branches of a tree by giving some attention to the position of each cut. If it is desired to give a particular branch an outward or a spreading tendency it should be cut off at a point just beyond a bud or a side branch that points in that direction. In like manner the growth of a spreading

branch may be directed upward by cutting back to a bud or side branch that points upward or inward. (See Fig. 1.) The wound on a branch that has been cut back close to a side branch is likely to heal over more readily than when a long stub is left at the end of the branch. In removing side branches the cut should be made close and parallel, or nearly so, with the parent branch. When long stubs are left the wounds do not heal over and sooner or later decay starts. It is usually in this way that wood-destroying fungi get into the tree, resulting in the familiar hollowed trunks. (See Fig. 2.) The cuts should be made as smoothly as possible to facilitate the healing process. To prevent the accumulation of moisture on the surface, large cuts are usually made in a sloping direction. Wounds of two inches or more in diameter should always be sealed up with paint, or other substance. Some careful growers use a thin grafting wax for this purpose. If the wounds do not heal over within two years a second coat should be given. Any ordinary lead and oil paint will answer the purpose, but it should not be applied until after the exposed wood has become thoroughly dry, and it should be used moderately thick to fill up the cracks.



Fig. 2. A Neglected Wound. Decay starting at this point, has extended far down the trunk. Large wounds should always be kept well coated with paint.

Pruning a Form of Training

Young apple trees require very little attention, with regard to pruning, until they reach the bearing age. The treatment should be one of training rather than of correction. That is, the trees should be gone over every year and encouraged to grow in the desired way. Several yearly trimmings will require no more time than a single pruning after a lapse of three or four years. Irregular pruning tends to throw the young tree out of balance, for the removal of so much wood in one year is always followed by a rank, succulent growth the following



Figs. 3 and 4. A Ten-year-old Apple Tree that has not been pruned since it was planted, and the same tree after pruning. Observe the open center.

season. Unless such yearly treatment can be given, it is probably better to delay pruning entirely till the trees reach the bearing age, when the maturing of a crop of fruit will offset to some extent the invigorating effect of severe pruning. Fig. 3 and Fig. 4 show a tree, before and after pruning, that has been treated in this way. If this method is employed, and if there is much wood to be removed, it would

seem advisable to remove some of the wood during the summer and the remainder in the following winter or spring. Summer pruning is a devitalizing process and has the opposite effect upon the tree to that of winter pruning. It also tends to induce fruitfulness.

The regular annual treatment may be done any time during the dormant season, and the operation consists in removing unnecessary growth and moderately heading-in the stronger growing branches. Much may be done in the way of directing the growth of the branches by cutting back to a bud the points in the right direction. If a spreading habit is desired, the cut should be made about an inch above one of the lower or outer buds. With trees that are naturally spreading in habit, on the other hand, a more upright growth may be induced by cutting back to a bud on the upper or inner side of a branch. Some growers rub off the buds that they do not want to develop. This is a doubtful practice and entirely unnecessary. The important point in the whole matter is the development of a strong, well-balanced structure with a large bearing surface. In pruning and shaping the young tree the grower should keep in mind the matter of convenience. He should endeavor to keep the tree as low as possible to facilitate the operation of spraying and harvesting. There is a tendency among the best growers to develop a tree with an open space in the center of the head. This is a great advantage in the way of admitting more air and sunlight, but it is possible to carry the matter to such an extent that the branches of the tree may be injured by exposing them to the direct rays of the sun.

C. D. JARVIS,
Storrs, Conn.

Pruning as Adapted to Iowa

In too many of our Iowa orchards the trees are permitted to grow any shape or density restricted only by the laws of nature. As a rule there are too many limbs, the foliage is too dense, and the apples toward the center of the tree do not color properly. As the tree gets larg-



Fig. 1. A Neglected Apple Tree.



Fig. 2. The Same Tree After Pruning.

er it becomes top-heavy and too many fruitspurs are formed. Following this condition the tree sets more fruit than it can properly mature and as the years go by the fruit gradually becomes undersized. Careful pruning simplifies and often renders unnecessary the thinning of the fruit. The best pruning is that which is done during the formative period. It is better to train the tree during its younger years than to use the pruning saw severely when it is grown. The head of the tree should be opened to admit the sunlight, and all branches which interfere should be removed. Any branch which is growing towards the center of the tree rather than outward should also be taken out.

In the removal of any large branches care should be taken to make the cut close and parallel to the remaining stem. Whenever a stub is left the wound will not heal properly. If the wound is more than two inches in diameter the surface should be coated with some antiseptic and waterproof material such as white lead.

The best time to prune in this section is after the severe weather of winter is past and from then on to the middle of May, with the exception of the brief period just at the leafing out time when the tree is liable to bleed badly.

For Iowa conditions a low-headed tree is to be desired for a number of reasons. The fruit is much easier to pick, the spraying can be done more thoroughly, there are less windfalls, and the tree is also less liable to sun scald. The first branches should be formed 20 to 24 inches above the ground. If the tree is headed too high when it comes from the nursery, it can be cut back, removing the stem at the point where it is desired that the first branches shall appear. Low-headed trees are sometimes objected to on the ground that they are difficult to cultivate under. In this connection, we would call attention to the fact that many growers make a far more laborious and difficult operation of cultivating than is necessary or desirable. The bulk of the feeding roots of the tree are in a zone at about the

end of the branches and in the space between the rows. It is this area that should be cultivated. There is little advantage in cultivating up close around the stem of a large tree as the feeding roots are not within this area. The main object of cultivation can be attained by keeping the middles and a short distance back under the branches stirred. This plan also admits of heading the trees low.

A. T. ERWIN,
G. R. BLISS,
Ames, Iowa.

Pruning in West Virginia

Intelligent pruning, at the right time, is absolutely essential to the production of the best fruit. An unpruned tree may, in many instances, produce a larger number of apples than an adjacent pruned tree; but the percentage of merchantable fruit will invariably be smaller. Small apples or peaches contain just as many seeds as do large ones, and therefore make practically as great demands upon the store of plant food. They do not, however, fill the basket, nor the pocketbook, so rapidly as the others.

When to Prune

The best time for pruning is on warm days from January to May. More can be accomplished in the longer days of April and May, but if there are many trees to be pruned, the work should be commenced earlier in the season. The time of year when the cut is made has little effect upon the readiness with which the wound heals, but more care is necessary to prevent injury to trees pruned when the wood is frozen.

A wound made by removing a limb heals best if the cut is made close to the trunk or branch. A stub two or three inches long does not heal and becomes a lodging place for spores of fungi and bacteria which cause decay and death of the tree. The splitting down of large limbs may often be avoided when pruning by sawing in from the under side first; but, in every case, see that the wound is left clean and smooth. Wounds should also be covered immediately with a coat of paint, shellac or grafting wax, to keep out the moisture and spores before mentioned. Nothing is

better for this purpose than pure white lead and linseed oil.

The whole philosophy of the pruning of plants rests upon the fact that the various parts are unlike; that each branch is, in a measure, independent and capable of becoming a new individual; that by lessening the conflict between the parts, the growth of the whole is promoted. Pruning is a necessity, and the pruning given by Nature in a neglected orchard or forest, is more severe than the average man would dare to attempt.

It is often urged that pruning should be commenced when the tree is planted, and continued annually throughout the life of the tree. It is doubtful, however, whether equally good results may not be obtained by removing superfluous branches at four or five years of age, rather than by severe pruning very early in the life time of the tree. In other words, it is contended by some that it is better to permit the root system to become thoroughly established before disturbing the top.

The amount of pruning necessary depends largely upon the location and exposure of the orchard. Trees on a warm southern slope, freely exposed to the winds, require much less pruning than do those in a cool sheltered location which is lacking in sunshine. Plenty of light is essential to the production of highly colored fruit. It is desirable that trees should be pruned intelligently from the time they are set, but old trees may often be given a new lease of life by judicious management. If the trees have been long neglected and require heavy pruning, do not remove all of the wood the first year. Removal of a portion of the top, thus distributing the food gathered by the roots to a smaller number of branches, tends to produce rapid growth and renewed vigor of the tree. The removal of too much at one time will start the growth of watersprouts and defeat the very purpose in view.

The method of shaping the top of young trees will depend upon the natural habit of the variety, the ideal of the grower, and the local conditions. No at-

tempt should be made to make all varieties conform to a given type, like trees in a hedge. In general, limbs which are parallel and close together, or limbs which cross and interfere with each other, should be removed or thinned. Trees of an upright habit, like Sutton or Maiden Blush, should have the center of the top opened, while trees of a spreading habit, like Jonathan or Rhode Island Greening, should have the lower limbs removed. To keep the trees within bounds, the leading branches may be cut back one to three feet about every other year until the bearing age is reached; after which the production of fruit should sufficiently check superfluous growth of wood.

The question of high heads or of low heads is a perennial one. In general, however, the tendency at the present time is to maintain as low heads as is consistent with cultivation. The ideal tree is vase-formed, the lower branches starting about two and one-half feet from the ground, and ascending in such a manner as to permit of reasonably close approach to the tree in cultivating. This may be accomplished by cutting off those limbs which tend to grow out horizontally or which hang from the lower side of the leaders.

Why Pruning Is Important

It is astonishing to find how little the average orchardist thinks, when pruning his trees, of the actual problems at issue. Pruned trees are almost always more vigorous than unpruned ones, because the food taken up by the roots is concentrated into a smaller number of branches.

Pruning is practiced to produce larger and better fruit; to keep the plant within manageable limits; to remove superfluous or injurious parts; to facilitate spraying, tillage and harvesting; to train the plant to some desired form.

Plants naturally grow from the uppermost buds. By pruning in one way this tendency is augmented, in another way it is checked. As a rule, in dealing with fruit trees, the latter end is desired, since the principle that "checking growth induces fruitfulness" is universally recognized. The heading in of young growths

tends to develop lateral and dormant buds, or to thicken the top, so the question of heading resolves itself into a question of personal ideals. To secure thick topped trees, heading is necessary. It has, however, the very marked advantage of inducing the development of fruit buds near the body of the tree, rather than far out on the limbs. This, in the case of plums and other tender wooded plants, is an important consideration.

Fruit bearing is determined more by the habit and condition of the tree, than by the extent of pruning. In other words, it is to a certain extent an individual characteristic. Pruning, however, may be made a means of thinning the fruit, and thus improving the size and quality of that which remains by removing superfluous shoots upon which fruit buds are borne. Heading back the annual growth thins peaches; but with the apple, pear and plum, which produce fruit on spurs or miniature branches, on wood of more than one season's growth, older limbs must, of course, be removed in order to effect the desired thinning.

W. M. MUNSON,
Morgantown, W. Va.

Opinions of L. C. Corbett

In pruning a fruit bearing plant like the apple, attention must be given not only to the height and formation of the head, but to the removal of wood as well. The apple bears fruit on spurs which are developed from wood one year old or more. For that reason, therefore, the removal of wood which carries fruit spurs reduces the crop the tree is capable of bearing. This, then, is a practicable way of thinning the fruit. Besides accomplishing this result pruning can be used to lessen the annual growth and force the energy of the plant which would naturally be used in making wood into fruit, thus increasing its size or enabling the tree to carry a larger quantity than would be possible were a normal wood growth permitted.

Forming the Head

Modern orchardists have come to look upon the low-headed tree as more desir-

able than those headed high. A head which is two and one-half to three feet from the ground is at present considered more desirable than one which is six feet or more from the ground. The latter height was formerly frequently used. In forming the head care should be taken to have the framework branches disposed at different heights along the body of the tree—say from three to six inches apart, and distributed as evenly as possible around the body as a central axis; that is, when viewed from above the picture presented would be that of a wheel, the hub being the central axis of the tree and the framework branches representing the spokes.

Main Branches

For an apple tree three branches are considered the ideal number. More may be left upon some varieties, particularly those which are strong growers and upon trees which have a well-developed root system at planting time. If, however, the roots have been badly mutilated in removing the tree from the nursery, it will be safer to reduce the number to three rather than to maintain a larger number. These three main framework branches upon the ordinary first-class nursery tree should not be more than 10 or 12 inches in length. At the close of the first season's growth after planting, each of these three framework branches should be considered as though it were a separate nursery tree, and, if possible, three subdivisions of this should be maintained for the wood supply of the second year, the three branches retained being cut back to about the same length as those originally held by the tree as planted in the first place. This operation should be repeated each succeeding year. By so doing a symmetrical development can be maintained, and by cutting to an outside or an inside bud the habit of the tree can be modified so as to make it upright or spreading in character. Some trees are normally upright in their habit of growth, while others are spreading. This must be borne in mind and the character of the variety under treatment must be taken into consideration in cutting the branches, so that they

will be upright or spreading according to the desire of the planter.

Effect of Cutting Back

This frequent cutting back of the branches of the tree while it is young prevents the long, bare branches which are so characteristic of old orchard trees. It also prevents the tree from growing too tall—a condition which makes it difficult to gather the fruit or spray the tree. With the low-headed trees less propping is necessary than with trees having long framework branches. The load of fruit is carried nearer the trunk, and the main structural branches being larger in proportion to their length are therefore better able to carry any load of fruit which the tree may develop.

Annual and Biennial Crops

Judicious pruning, as has been pointed out, not only facilitates the work of cultivation and spraying, but at the same time determines to a very considerable extent the fruiting habit of the tree; that is, the quantity of bearing wood which a tree carries can be modified by pruning so that it will be practically impossible for the tree to retain more fruits in any given season than the root is capable of supplying with a proper amount of nourishment. With such a balance between the fruit bearing wood of the tree and its root system maintained, biennial crops will be less likely and annual crops will be more common. Orchardists in general are coming to believe that the reason for the biennial crop in many orchards is due to the fact that during the crop year the trees are allowed to overbear, and that their vitality is therefore so much reduced that it is impossible for them to carry a satisfactory crop the succeeding year. The thinning of the fruit, with the result that a crop is borne each year, has convinced practical growers that overbearing is the cause of the biennial fruit production.

Pruning for Fruit

With fruit trees pruning is important because it can be used for the purpose of checking the growth as well as for the purpose of thinning the fruit. It is an old and well established maxim among fruit

growers that whatever tends to check growth increases the fruitfulness of the plant. Pruning can be used to accomplish this result to a certain limited degree. Plantations which are tardy in coming into bearing may, therefore, by judicious pruning, be brought into profitable production.

Accelerating Growth

Contradictory as it may at first thought appear, pruning is frequently resorted to to accelerate or augment growth in plants. Weak growing nursery stock is frequently severely cut back during the resting period in order that all the strength of the root may be forced into the formation of a single upright stalk which will make the plant a salable nursery tree.

Rejuvenation of Old Trees

Severe pruning is also resorted to with older plants for the purpose of rejuvenating them. Old apple trees and old shade trees are frequently so treated, in order to induce them to throw out strong new shoots.

Effect on Fruit Crop

With such plants as the peach, which bears its fruit upon the growth of the previous year, pruning is of great importance, as the grower can reduce the crop in proportion to the capacity of the tree. Successful fruit growers thoroughly understand the importance of gauging the quantity of fruit allowed to be borne by a tree to the capacity of the tree, the ability of the tree in this respect being measured by the rate of growth, the variety, and the soil and climatic conditions to which it is subjected.

Control of Disease

Pruning is of prime importance also in controlling the action of some of our most dreaded plant diseases. The study of pear-blight, for instance, has shown that this disease is very generally communicated from plant to plant by insects, through the pollen, as they pass from blossom to blossom, or, later in the season, from shoot to shoot. It is also believed that the disease can be carried by the wind and that infection can take place while the vegetative processes are active and the tissue

at the ends of the branches can easily be entered by the germs of the disease.

L. C. CORBETT,
Washington, D C

Pruning as Taught by W. S. Thornber

Every tree is a rule unto itself and no two trees can always be pruned exactly the same. The pruner should be quick to detect the weaknesses as well as the strong marks of a variety or individual. He must be elastic in thought and perception as well as application or he will ruin many a valuable tree. His duty is to make the best of every individual tree regardless of its condition or shape.

While it may be possible to grow a successful orchard in some places without pruning, it is an absolute impossibility here in the West. The successful grower must prune every year at least once if he would have perfect trees.

When to Prune

There can be no best time to prune all varieties and ages of trees in all climates. The vigorous growers and shy bearers on rich moist soil should be summer pruned as well as winter pruned, or at least summer pruned; while the slow growers and heavy bearers should always be pruned during the winter. One must constantly remember that heavy winter pruning tends to stimulate wood growth while heavy summer pruning tends to develop fruit buds.

The essential thing in a young tree is that it make strong, rapid growth, and so it should be pruned during the dormant or winter season to induce this growth. As soon as it becomes large enough and old enough to bear this winter pruning may or may not be modified or even supplemented by summer pruning. The essential thing in an old apple tree is that it produce fruit and so it should be pruned in such a manner that it will produce fruit. In Eastern Washington and most of the irrigated valleys the trees produce fruit too young and tend to overbear, while in Western Washington the reverse is true. With these facts before us it is easy to see why it is best to prune the young trees and most of the old ones in the central and eastern parts of the state

during the winter and all of the bearing trees in Western Washington during the summer season.

How to Prune

Pruning is an operation that should not be done carelessly or hurriedly. The pruner should study each tree as he prunes it and each branch as he removes it.

When heading back young trees or cutting off the tops of the last year's growth out of older trees, the cut should be made slanting away from and about one-sixteenth of an inch above the first bud that is intended to grow. A longer stub than this will dry, crack and form an entrance for fungi, bacteria, etc. A shorter stub will usually result in the death of the first bud.

When pruning trees that have a dense upright habit of growth, like the Wagener, Rome Beauty, etc., cut to strong outer buds in order to spread the naturally narrow, compact top, but when pruning spreading or slender growing trees, cut to buds that point toward the center of the tree in order to throw the limbs inward and upward.

Weak growing trees or weak branches in strong trees may be compelled to produce strong growths by severe winter pruning. In the removal of lateral branches from either young or old trees cut parallel with and close to the main stem. Never leave stubs from one to two inches long in hopes that they will develop into fruit spurs, since less than five

per cent ever become fruit spurs and the other 95 per cent die, dry up and leave excellent gateways for the entrance of disease into the wood of the tree. Young lateral branches when shortened back, specially after the spring growth has taken place, very frequently develop fruit buds and spurs.

In the removal of large branches from old or bearing trees always make the cut parallel with the branch or main stem from which the one is removed. This frequently means a larger wound than it would make if the cut is made at right angles to the limb that is to be removed, but such wounds will heal quicker and are less injurious to the tree than the much smaller ones that leave the collar of the branch to be covered with healing tissue. Do not hesitate to remove large, useless or superfluous limbs from trees, but always make smooth, clean cuts with a saw, and if necessary to prevent splitting the stem or peeling the bark, make two cuts—the first from six to twelve inches out from where the limb is to be finally cut off. Nothing can be applied to the wound to hasten the healing. Wounds an inch or less in diameter need not be treated, while large wounds may be advantageously treated with a thick coat of lead paint. Cheap mineral paint or tar should not be used upon fruit trees as it kills the young, tender bark while grafting waxes crack and peel off before the wound has healed. Any antiseptic that will keep the moisture out makes an excellent coating.

The early training of young trees is very essential since it is necessary to develop a good frame while they are young if it is ever to be developed. It is almost an impossibility to make a first-class tree out of an old neglected tree. One of the differences between eastern and western fruit growing is in the method of the training of the young trees. In the East the high headed tree is the rule while in the West it is the exception. Practical fruit men no longer strive to head their trees high enough for the average horse to work under, but head their trees low and then secure extension tools in order to till all of the ground.



The Left Hand Figure Shows Where Branches Should Be Cut in Pruning Apple Trees. Such wounds readily heal.
The Right Hand Figure Shows the Perfect Healing of a Wound Made by Pruning Away a Branch.

The low headed tree has many advantages over the high headed tree. As a rule no apple tree should be permitted to start its head farther than 18 inches from the ground, nor closer than six inches from the ground. A tree with more than 18 inches of stem places its fruiting plane almost entirely out of reach of the average man for thinning, harvesting, etc., while the tree with less than six inches of stem is very apt to have trunk rot or to readily split when heavily loaded with fruit. If the West desires to continue to lead in the production of fancy and first-class fruit her orchardists must keep the fruiting planes of their trees within easy reach of the ground for thinning, spraying, and harvesting. Our experiments and observations teach that the following methods give the best results for the training of young apple trees:

First Year

Prune the newly planted one-year-old tree in the spring just before growth begins to a straight whip unless it means the removal of a large number of buds from that part of the stem between 12 and 24 inches from the ground; in the latter case, cut the laterals back to short stubs from one to three buds in length. The smooth pruning gave the best results where it was possible to practice it. After pruning to a whip, cut the top off just above a bud from 18 to 24 inches from the ground. Varieties like the Jonathan may be cut at 18 inches or less while varieties like the Rome Beauty and Wagener should be headed a little higher. It is frequently difficult to secure sufficient well placed branches upon a large one-year-old transplanted Wagener if it be cut off closer than 24 inches from the ground. If the lower buds for the first 12 inches from the ground start to grow they should be rubbed off early in July unless the stems of the trees are slender and need to be thickened when the buds should be permitted to grow until August or even the following spring, unless they form very strong growths.

Second Year

Select from five to seven of the best placed limbs to become the framework of

the tree, securing as many as possible that point in all directions and that are as far apart on the main stem as possible. Cut off the others close to the main stem and prune the selected ones back to from one-third to one-half of their original length, leaving the most central one as a leader which should be cut from four to six inches longer than the others. The exact length the framework limbs should be left must be governed entirely by the year's growth. Eight inches should be considered the minimum length and 18 the maximum length. In the case of upright growing varieties prune to outer buds while in the case of spreading sorts prune to inner buds and thereby correct the evil. In windy exposures turn as many limbs as possible toward the wind; also prune the branches very severely on the windward side.

Third Year

Select from two or three limbs per branch of the frame, remove the broken, diseased and superfluous branches, and cut the selected ones back to from one-half to two-thirds of their original length. Again the best length to leave the branches must be governed by the growth. Eighteen to 24 or even 36 inches are reasonable lengths. The leader should still be maintained and the top carefully balanced in order to avoid undesirable growth. It is sometimes necessary to remove one or more of the framework branches to open the top. This is always allowable and frequently advantageous in the forming of the top.

Fourth and Fifth Years

Select from one to three limbs per branch that were left the preceding year, remove crossing, diseased and superfluous wood and cut back the selected limbs very little and unless the growth is very strong little or no topping is necessary. Thin the top and center as much as possible without leaving it entirely open. In the case of long growths, cut back severely to a branch if possible. In fact, all pruning from now on should be of a thinning and very light topping nature. In the fourth to fifth year, summer pruning should begin to be practiced in sections

west of the Cascades and may be advantageously used with shy or tardy bearers anywhere.

The Pruning of a Bearing Tree

An old apple tree that is in full bearing should be carefully pruned every year, removing almost as much wood each year as it produced the preceding year. Care should be exercised to keep the top open, balanced, free from crossing or rubbing limbs and from getting too high. A top can be lowered or raised at will if the pruner will study his branches. Always cut back to a branch, and never leave a long stub unless water sprouts are desired. If the tree has been neglected for years, remove the superfluous wood by degrees about one-third of the total amount to be removed each spring and summer until the desired top is reached. Pruning is a matter of common sense and should be practiced as such. The young tree is elastic and can be easily shaped while the old tree is established and must be compelled by severe methods.

W. S. THORNBER,
Lewiston, Idaho.

Location of Fruit Buds

A knowledge of how and where fruit buds are formed is very necessary to the best results in pruning as the ultimate object of pruning is to produce fruit. The best way to learn where the buds are produced on trees is to examine trees in an orchard under the direction of some one who can explain the difference between leaf buds and fruit buds. We can point out where they are to be found, thus making it possible for one not acquainted with the different buds on trees to distinguish between them when a competent instructor is not available.

On apple and pear trees the fruit buds are found on the ends of short spurs which are one or more years old. The terminal growth of these spurs is produced from the topmost lateral bud which often causes the spur to be more or less zigzag in shape. When the fruit spur is making terminal growth it usually will not at that time produce fruit nor will a fruit bud generally be formed on a fruit spur the same season that fruit is pro-

duced. It follows, then, that fruit spurs on apples or pears will as a rule bear only in alternate years. The leaf buds are both terminal and lateral, the flower bud always terminal. Flower buds may be distinguished from leaf buds by being somewhat larger, with a point that is blunt or rounded, while the leaf buds are smaller with a sharper point. The fruit buds of cherries and most plums are produced much the same as those of apples, except that the buds are often in clusters and are sometimes lateral on short spurs.

The fruit buds on peach trees are lateral and are not found on fruit spurs, the buds usually being formed in the axils or leaves on the current year's growth. In pruning peach trees the tree should be pruned in such a way that a liberal supply of new wood is made each year, while in apples, pears, plums and cherries the production of new wood is not so necessary, as the fruit spurs on these will continue to bear for a number of years. The fruit buds on currants and gooseberries are formed much the same way as on apples. They are not productive for as long a period, however, and require such pruning as will produce new spurs every three or four years. The fruit buds on raspberries, blackberries, dew berries, etc., are formed the same season that the fruit is produced, the fruit buds being formed on the ends of the shoots which grow from lateral buds on the main stem the same season that the fruit is ripened.

R. W. FISHER,
Bozeman, Mont

Tree Support by Intertwining Branches

A method of supporting the branches of a tree, without propping, has been tried and found to possess considerable merit. It is a method of wrapping, or twisting together small branches projecting from the main limbs. These branches point in different directions, and tend therefore to meet and to grow beyond each other. This makes it possible to intertwine them, by which process they tend to grow together and to become permanently attached. Becoming permanently attached, they grow with the growth of the tree and become permanent supports completely binding

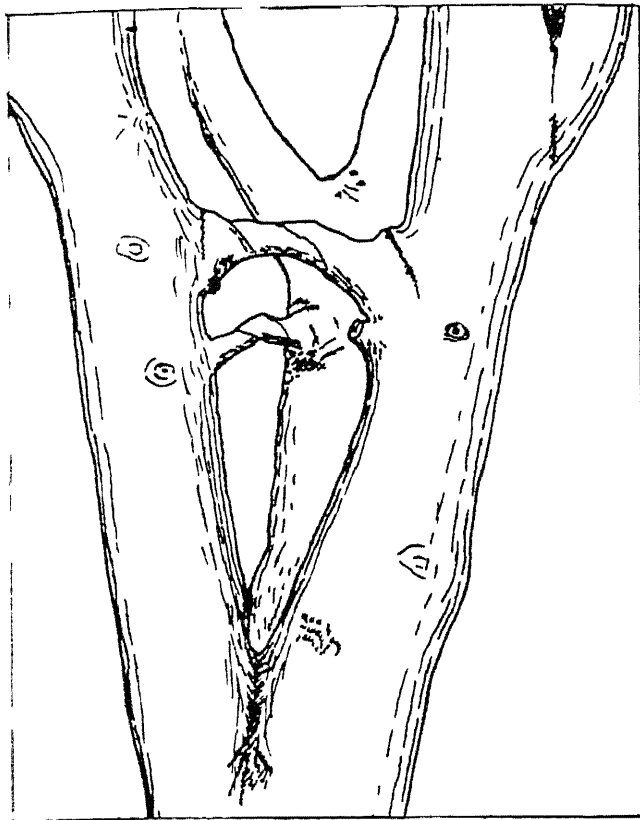

Fig 1 Live Wood Bolts

limbs together. This is better than any system of propping, because it does no injury to the bark of the limbs, as is true with props, as the wind sways the branches and chafes the bark. It is better than the system of wiring, for wires can only be fastened to the limb by means of wrapping around the branch, or by means of a small hole through it. In either case the limb is more or less injured.

GRANVILLE LOWTHER

How to Grow an Annual Crop of Apples

The habit of some trees to bear irregularly, or to bear every second year, has led to a discussion of the question, "How to make our trees bear a crop annually." This has been done in many instances by pruning and thinning. The trees are thinned to a fair crop each year instead of being allowed to bear heavily one year, and then a light crop the next year. Further, summer pruning causes the formation of fruit spurs, and tends to produce a crop the following year.

Mr. John R. Moulton of Weiser, Idaho, gives some good advice adapted to conditions in that country, and we believe adapted to many other sections as well. Mr. Moulton says: "The pruning is a very important part; should be done annually;

not too heavily; cut out all the dormant limbs, and on an old tree that has been bearing heavily, cut out part of the old fruit wood and allow new wood to start. By so doing a process of rebuilding and rejuvenation is continually going on. The tree must be thinned down to what it will bear without breaking. All clusters must be thinned to one apple on a fruit spur, and no two apples should be left close enough together to touch. The most important of all, is the question of irrigation, during the months of July and August. During this period, the orchard must be kept wet enough to keep the fruit growing continually. I believe there are more mistakes made in watering an orchard, than in any other one thing connected with orchard work. The orchard must be kept wet enough to mature a crop of fruit and a crop of buds for the next year. A cover crop will form a mulch that will prevent the sun from baking the soil."

Pruning Relation to Fruit Bearing

The purpose of every plant is to produce seed, and this seed in turn a like plant.

So in order to produce fruit, which is but the husk or covering of the seed itself, we must follow Nature as much as possible.

To begin the tree at planting time, we must build a framework that will permit of the most exposure of foliage to direct or indirect sunlight. Sunlight is absolutely essential to plant life. Nature has arranged the leaves on the branches in such a way as to receive as much light as possible. We therefore choose the open-center or vase-shaped tree as the shape best suited to the needs of the apple or pear.

Each tree should have three to five well spaced frame limbs, well distributed upon the trunk of the tree, forming thus a strong whorl that will carry heavy loads without splitting. The tree, either apple or pear, should be cut back and limited to not more than 18 to 24 inches of annual growth depending upon the caliper and strength of the limbs.

Starting at one year from planting with three or five limbs we will continue

these in vase form for three years until we have reached a height of four or five feet, with a top spreading at least three feet, when we should commence the doubling of each of our five branches. We should always attempt to keep all the tops level or nearly so, as the doubling commences the third or fourth year. Meantime there has been more or less branching of small limbs on the main lateral limbs. Some of these should be left, but only those that are not showing a strong tendency to produce wood too abundantly.

In thinning out these trees be sure to leave a few of these cross-limbs both inside and outside, but not so low that they will interfere with close cultivation.

They should be so left that the upper ones will not shade the lower ones too much, and yet have enough left that the system may be practical, as these branches will produce the first fruit and this puts the fruit farther away from the frame limbs, thus preventing heavy loss from blight infection as the buds on the heavy limbs sometimes do.

Each of these short limbs should be tipped slightly to insure development of all buds on each limb.

The production of fruit spurs being dependent upon the first and second year's development of the bud, it is very necessary to allow as much sunlight as possible inside the tree. In many cases there is a strong tendency to over-prune and cut back heavily, which should be avoided as much as possible and yet produce a strong frame work.

In all normal plants there is a heavy root pressure that is caused by the rapid absorption by root tips of soil water and this is forced upward into the limbs and small branches. This root pressure which can be measured in pounds of pressure must be reckoned with when we cut off the tops of rapidly growing trees and thus increase the pressure in the remaining limbs.

The early fruiting limbs, before mentioned, help to equalize this increased pressure and help to maintain a better balance between top and roots and hold

the tree in check more or less. As a matter of fact, these limbs absorb their share of plant food and if not tipped too heavily will set in their second year an abundance of fruit spurs.

At the end of the second year's growth of these side branches, if the buds are prominent on the older part of the limb and look like fruit spurs, the branch can then be cut back to allow only as many blossoms as needed to appear. While the tree has been busy setting this fruit, the tops have been making rapid growth of three or four feet annually, which must be cut back some to prevent the tree arching too near the ground. We should never allow more than three limbs to remain at the tops and two are really better. In all cases of early bearing due consideration must be given for future crops and the small amount of fruit we get in the fifth and sixth years is, although commercial, useful in bringing the tree into earlier bearing than heavy pruning methods and also does not hinder development as some people fear when the tree is cropped too heavily.

Our aim from the fifth year on should be to have sufficient two-year-old wood always in readiness to produce an even crop on all parts of the tree.

This can only be obtained by thinning the branches both inside and outside each year, and after the sixth year topping should not be resorted to in the apple except in exceptional cases and then to a lateral if possible.

Pears, however, as a general rule, need to be topped annually to prevent terminal fruits which are of little commercial value.

Winter pruning is recommended for general practice, as the work is more satisfactory, can be done quicker and better, as the limbs show their ages better when dormant and as the tree grows older, we should try to cut three and four-year-old wood that is not frame wood, rather than so much young wood on the outside of the tree.

Summer pruning is very useful in the training of young trees as any low, superfluous limbs can be removed, as also any that tend to pull a frame limb out

of position, or that crowd too thickly in the center and obstruct the light too much. Heavy limbs that, helped by the prevailing winds, are twisting strong laterals out of position should be cut and allow the limb to right itself.

Tipping the side fruiting branches slightly during the summer has a tendency to help the setting of fruit spurs.

The low temporary fruiting branches can be used for a few years until they have been superseded by higher limbs when these first useful limbs can be cut away and leave a clean open frame work, proof against blossom infection.

CLYDE BARNUM,
Phoenix, Oregon

Forcing Newtowns Into Bearing

(Rogue River Valley)

The writer had quite a large block of Newtown apples growing in a heavy, black deposit soil, which was very rich in plant food. The trees had reached an age of eight years and were large, healthy and beautifully shaped, but not a single fruit bud had appeared. The ninth year started with the same conditions when it was decided to radically change the methods of growing these to see if they could not be brought into bearing. These trees had been pruned regularly each year and the wood growth was enormous. This being the fact, pruning was discontinued and not a branch was cut. At the end of the season the trees were a mass of brush but still no fruit. The following season one or two large branches were removed from trees needing it and some of the brush removed from others, care being taken not to cut out much from any one tree and never to head back. At the beginning of the third season a few blossoms were noticed, but the soil was so strong that it seemed to push the growth of the trees into wood instead of fruit, no matter what was done. It was then decided to plant the orchard to barley. This was done and the entire block seeded right up to the tree trunks. The grain was allowed to ripen, and threshed out over 40 bushels to the acre.

This block was not ploughed and when spring came the barley had come up as

a volunteer crop and the trees had a good sprinkling of blossoms. It was decided to try and save both the apples and the intercrop of grain, so about four furrows were ploughed next to the trees and this was kept cultivated. When the grain was prime for hay it was cut. Immediately afterwards it was plowed and cultivated so as to keep a good mulch to conserve the moisture in the soil. This was necessary as irrigation was not used. When the apples were picked the trees averaged about two boxes each and the fruit was all good size and quality.

In the spring the soil was ploughed and has been cultivated and kept free from all growth between the trees as the trees were well set with fruit.

It must be borne in mind that the soil conditions were such as to produce a strong, heavy growth of wood, and the discontinuance of pruning did not act quickly enough to arrest this as desired. Therefore it required the additional cropping between the trees to check this growth of wood. The block is now in bearing and will undoubtedly continue to bear and we still follow the rule to prune lightly and not head back.

A. C. ALLEN,
Hollywood Orchards.

REJUVENATING OLD ORCHARDS

With renewed interest in the fruit industry, there has arisen a question as to the practicability of renewing or rejuvenating old orchards. There are orchards in some states which have reached an age of more than 50 years and show every evidence of neglect. Will it pay to attempt rejuvenation? That depends on the circumstances, but in general I would say it will not, and for the following reasons:

First: The trees can never be made to bear as good fruit as new trees that have been properly cultivated and have never been neglected.

Second: New trees can be grown at about the same cost, or perhaps at less cost than that of expensive pruning and rejuvenating the old orchard.

Third: In these old orchards are many vacant spaces where trees have died. In

order to fill these spaces it would be necessary to set new trees, but new trees do not grow as well in these spaces as they would in ground that had not formerly been occupied by trees. Considerable difference of opinion exists as to why this is true. Among the reasons assigned are that the old trees have absorbed a large proportion of the soil fertility, and that insect pests or diseases will attack the new tree in large numbers and with considerable vigor. These pests or diseases may be on the old roots where the new tree is planted.

Fourth: The fruit grown in these old orchards can not be marketed successfully in competition with fruit grown under other conditions.

Fifth: The life of a rejuvenated orchard, counting from the time of rejuvenation, is not long. In the nature of things it could not live to bear profitably for very many years, while the young orchard when it comes into bearing would naturally have a long life.

Sixth: These old orchards are generally not the best selections of fruit. The experiences of the past generation have taught us very many things, in regard to the best market varieties, which could not have been known when the old orchards were planted. Therefore the new orchards are much more profitable than the old.

I think, ordinarily, it would pay to plant a new orchard, perhaps letting the old one stand until the new one comes into bearing, and certainly not planting the new on the land of the old one. However, there may be circumstances where it would pay, and where it is for other reasons desirable. The views of several experienced and observant men are therefore given.

GRANVILLE LOWTHER

An Indiana View

Nearly every farmer in Indiana has been or is now interested to some degree in fruit growing. Many have been interested enough to set out a home orchard and then on account of the demands of the other farm work have neglected the orchard and have allowed it to degener-

ate until it presents an appearance which the fruit tree lover is pained to see. Many an orchard, set by the passing generation, during its earlier years a source of pleasure and profit, is now apparently in the "downhill of life" and to all appearances good for little. A large proportion of these orchards might, by proper methods, be so rejuvenated and have their youth so renewed that they would again bear good crops of sound fruit. Where this can be done, it is surely much better than to set a young orchard and wait several years for it to begin to bear.

At the present time a revival of interest is taking place in the question of home fruit growing, and many who own neglected orchards are seeking information as to the right thing to be done to restore them to usefulness and how to set about doing it.

J. TROOP,
C. G. WOODBURY,
LaFayette, Ind

An Ohio View

Nearly every Ohio homestead has a greater or lesser number of old apple trees—usually of desirable varieties. As a rule they have attained such extreme size and height that it is with great difficulty that the all-important work of spraying can be accomplished. If these trees were originally headed quite low and yet retain their lower branches in fairly vigorous condition, the topmost branches may be cut back severely, lowering the height of the trees materially and rendering the work of spraying, gathering fruit, etc., much more readily done. The type of trees which cannot be successfully headed down are those which have long, naked branches extending to a considerable height before diverging into smaller branches. In heading back an old tree it is well to make the cuts just above diverging branches, if possible, as the wounds thus made will heal much more easily than if made midway between diverging branches. All wounds should be well painted with a thick lead and oil paint.

Heading back large trees will result in a vigorous growth of young shoots springing up from the upper branches, and in the entire tree taking on new life. The

stronger shoots in the tops of the trees should not only be thinned out each season where too thick, but those remaining after thinning should be cut back with the pruning shears from one-third to one-half their length. In a few seasons this new wood, thus restricted, will begin to form fruit buds and bear fruit. In the meantime, with thorough fertilizing, cultivation or mulching and spraying of the trees, their lower parts should be producing plenty of fine fruit.

F. H. BALLOU,
Wooster, Ohio.

Factors To Be Considered

In the campaign for the revival of the apple industry in New England, the first item to present itself is the improvement of the existing orchards. Logically it is the business of the fruit grower to first make the best use of what he has on his farm. The interim between the planting of a young orchard and the gathering of its first fruit may profitably be spent in improving some of the best run-down apple trees. The possibility and the advantages of renovating neglected apple orchards have been so clearly demonstrated, that during recent years many old orchards have been purchased with this object in view.

The neglected orchard is the usual thing in New England and the well-cared-for orchard the exception. In every section can be found apple orchards that are not as profitable as they should be. Some, consisting mostly of small plantings around old homesteads, were started during the early part of the last century and have passed their period of usefulness. Others, of more pretentious dimensions, were planted about 1850 and, if they had been properly cared for, they would be producing profitable crops at the present time. There are also many others that vary in age from 20 to 40 years, and that, under rational management, should be producing maximum profits.

Will It Pay

In the matter of orchard renovation the first question to present itself is, "Will it pay?" In order to answer this question

intelligently several points should be considered:

1. *The attitude of the man.* The owner of the orchard should first decide whether in the future he will give the trees proper treatment with regard to tillage, fertilization, pruning, thinning, and spraying. If the orchard is under new management, it is more likely to get satisfactory treatment than if under the management of the man who previously neglected it. Not every man can make a success of fruit growing. Some men have not the taste and would do well to leave this phase of agriculture to those who are more interested.

2. *Age and vigor.* It will seldom pay to undertake the renovation of apple trees that are over 30 or 40 years of age, or those that show serious lack of vigor. Trees that have been repeatedly defoliated by canker worms, usually lack vigor and respond to treatment very slowly. Or if the disease known as apple canker is abundant, manifested by many dead limbs and decayed spots on the trunk and main branches, it would probably be more profitable to relegate the trees to the wood pile.

3. *The position of the head and the general shape of the tree.* In earlier plantings, high headed nursery stock was commonly used and the close planting of the trees has tended to make them higher. On account of the difficulty of spraying high headed trees and the added expense in harvesting the fruit from such trees, it is not advisable to undertake the improvement of an orchard composed largely of very high headed trees. Providing, however, that the trees are not too old, good results may be expected from the renovation of moderately high headed and long-armed trees by severely "heading in."

4. *The stand of trees.* It will not pay to cultivate and fertilize an orchard if there are many vacancies. On the other hand, in some orchards the trees are so closely planted that it becomes necessary to remove a number of them, and in such cases, a vacant space here and there may prove to be an advantage. It is not advisable to attempt to grow other crops

in the vacant spaces, nor is it satisfactory to start young trees in an old orchard. When the trees to be renovated are along the roadside or a line fence, the vacancy factor may be ignored. In orchards where less than 60 per cent of the trees remain, the best practice would probably be to pull them all out and start a young orchard.

5. *Character of soil.* The apple thrives well on a great variety of soils, varying from sandy loam to heavy clay, providing it is well drained and otherwise well cared for. The chances for success are much better, however, where the orchard to be renovated is located on sandy or gravelly loam, or even clay loam, than where located on either light sand or heavy clay.

6. *Exposure.* Many of the older orchards are on "bottom lands" along the valleys, where they are more likely to be affected by late spring frosts, as also are those located on the southern slopes. Others are found on sites exposed to the strong west winds, where much loss is often occasioned by the fruit being blown off. Again orchards are often found on cold, springy hillsides where the soil does not warm up readily in the spring. Such a condition, however, may be improved by either surface ditching or underdraining. The renovation of such orchards, will prove less satisfactory than of those located on a high and protected northern or eastern well-drained slope.

7. *Presence of scale.* The control of the San Jose scale in old apple orchards is a difficult problem, and requires unusual perseverance and determination on the part of the grower. Unless one has had experience in controlling the scale in apple orchards, it probably would be unwise to undertake the renovation of a scale-infested orchard. By severely cutting back the branches, by scraping off all rough bark, and by repeated sprayings one is likely to succeed, but it is certainly very expensive and discouraging work, at the best.

8. *Varieties.* The question of varieties, while by no means the least important factor in successful renovation, is considered last, for the reason that this is a fault that may often be corrected by

top-grafting. If, however, an orchard is made up of a large percentage of undesirable varieties, it might better be used to increase the size of the wood pile, for it is a long, tedious, and expensive job to graft over large apple trees.

In summing up, then, we may say that success in renovating neglected apple orchards depends upon the age, shape, stand and vigor of the trees; upon the location of the orchard with regard to soil, altitude and exposure; and, most of all, upon the attitude of the man.

How to Proceed

As no two orchards are just alike, each will require special treatment, and, for this reason, it is impossible to lay down any hard and fast rules to be followed in all cases of orchard renovation. While it is true that in some orchards particular attention should be given to one or more phases of the renovating process, the best results will come from giving the very best treatment all along the line. After going to the expense of cultivation and fertilization it would be a short-sighted policy to allow the apples to be eaten up by worms or to be disfigured by disease.

Orchard renovation is necessarily a rejuvenating process and the treatment, with some modification, is the same as that required for a young orchard. The trees, after being stimulated into activity, are maintained in a healthy condition by regular methods of tilling, feeding, pruning and spraying.

Having decided that the orchard is worth renovating, the trees should be given a general awakening. The severity of treatment will depend largely upon the condition of the trees. The index to the health of a tree is the amount of annual growth, which with a normal tree is from 6 to 18 inches. The spur-like growth, usually observed on neglected trees denotes a lack of vigor. When the annual growth at the ends of the twigs is small, or not more than one or two inches, the treatment should be more severe in every way, than when the yearly growth exceeds this amount.

Pruning

If the orchard is composed of suitable varieties, and the trees are not to be top-grafted, the first operation will be that of pruning. In many orchards the trees are too closely planted. That they have not commenced to crowd is due more often to a lack of vigor than to proper spacing. The renovated orchard under favorable conditions will soon require more room. The larger growing varieties like Baldwin, Rhode Island Greening, Northern Spy, Roxbury Russet and many others will eventually require 40 feet between the trees. With the small growing sorts like Transparent, Oldenburg, Wealthy, McIntosh and others, 20 to 30 feet may be sufficient.

Thinning the Orchard

The first step, then, is to determine if the trees are properly spaced. If they are found to be too closely planted and if some of them must be removed, it is well to follow some regular order so as to retain the conformity of the orchard.

Where trees are planted in squares, as is commonly the case, every alternate tree in the row may be removed. If the first tree of the first row is retained, the first tree of the second row should be removed. This is done by taking out every second row diagonally. This method, it will be seen, leaves the rows cornerwise of the orchard. If the squares between the trees were originally 25x25 feet, they would now be 35.3x35.3 feet. If originally they were 30x30 feet they would now be 42.4x42.4 feet. So that by removing half the trees it does not follow, as is commonly supposed, that the trees will be twice as far apart as before.

In order that the diagonal rows to be removed may contain the largest possible number of vacancies and inferior trees, it is well to make a diagram of the orchard, locating on it all desirable trees by a particular sign, all weak trees and trees of undesirable varieties by another sign, and all vacancies by another. The result would be something like Fig. 1.

As to whether one should start by removing the first diagonal row, or the second, may readily be determined by re-

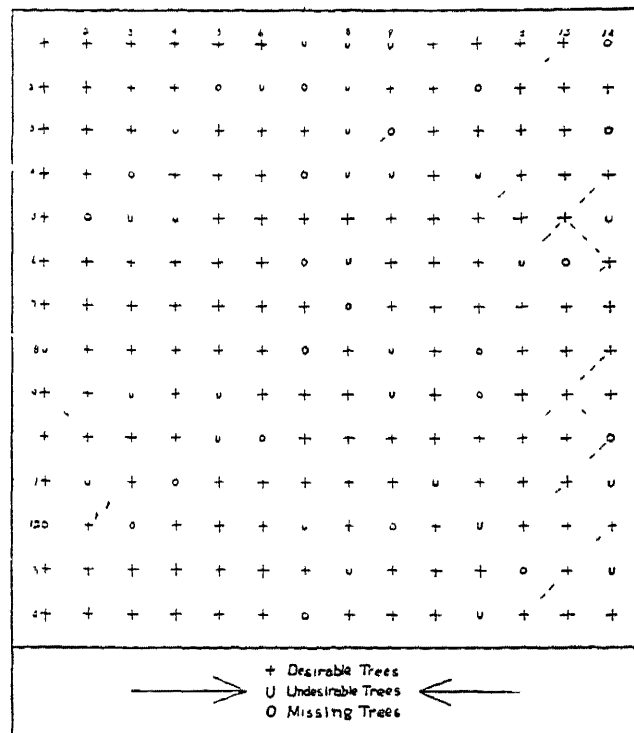

Fig. 1. Diagram Showing Method of Thinning Orchards. The dotted lines show the rows that are retained

ferring to the diagram. The even rows, as shown in the accompanying figure, include 19 vacancies and 18 weak or undesirable trees, while the odd rows include only four vacancies and 11 undesirable trees. In this particular case, then, it would be advisable to remove the even, diagonal rows, which include 37 out of the total of 52 vacancies and undesirable trees. The rows that remain include four vacancies, and the question may arise as to whether the trees adjacent to these vacancies should be removed. In some cases it may be advisable to leave such trees, but it must be remembered that each one so situated is likely to crowd one side of three other trees. An investigation by the Cornell Experiment Station shows that, within certain limits, the more trees per acre, the less the yield. Their results are based on the records of hundreds of orchards and cover a period of four years. A brief summary follows:*

	Bushels Per Acre
Not over 30x30 feet	186
31x31 to 35x35 feet	222
36x36 to 40x40 feet	229

Shaping and Thinning the Trees

Most trees are too high and may be greatly improved by cutting back the

* Cornell Experiment Station Bulletin 226, p. 301, 1905.

upper branches. A tree that is 30 feet or over in height often may be shortened by 10 or 15 feet, and one between 25 and 30 feet often may be cut back to about 15 or 20 feet. The horizontal branches, as well as the upright ones, may be cut back to advantage, especially with trees seriously lacking in vitality, and also those infested with scale. In heading back the upright branches, the cut is usually made just above a side branch that points outward. This tends to make the tree more spreading in habit. With trees that are naturally spreading and where a more upright growth is desired, the cutting may be done just beyond an upright side branch. If this method is followed with all horizontal branches, a much stronger structure will be the result.

The severity of heading-in will depend largely upon the vigor of the tree. Nothing will start a tree into renewed vigor like severe pruning during the dormant season. The cutting-back, therefore, should be more severe with weakened trees. With moderately vigorous trees,



Fig. 2. A Fairly Common Form of Apple Tree. The white lines indicate the points where the chief cuts should be made in pruning a tree of this kind. Besides the branches indicated, much of the brush should be removed from all parts of the tree. Many of the best branches have been removed from the lower part of the tree in former years.

there is danger of producing a rank growth in the form of water sprouts. If it is desirable to severely head back such trees, it is better to do it gradually, a little each year, and withhold all nitrogenous fertilizers. A still better plan would be to remove about half of the required amount of brush during the winter, and the remainder during the growing season. The effect of summer pruning upon the vigor of the tree is just the opposite to that of winter pruning and will counteract the stimulating effect of the latter. With most of the neglected orchards, however, the vitality is so low that most of the pruning may be done, without fear of injury, during a single dormant season.

The severity of cutting back will also depend upon the presence of scale. The work of spraying is greatly simplified and the chances for success in controlling the scale are greatly enhanced by extreme methods of pruning.

After the trees have been sufficiently headed in, all dead and diseased branches should be removed, and also such other branches as are necessary to produce a condition favorable to the free circulation of air and the admission of sunlight. While it is possible to over-do the pruning process, especially with the best of neglected orchards, the average man is more likely to err in the other direction.

Taking Care of Wounds

The universal rule in pruning is that all cuts should be closely and smoothly made and that the larger wounds should be painted over to keep out wood decaying fungi. The smaller wounds heal over quickly and will take care of themselves. Before applying the paint, the wood should be allowed to dry. Common lead paint, made up of white lead and boiled linseed oil, is very suitable for this purpose. If desired, a small amount of coloring matter, such as lamp-black, may be mixed with the paint so that the spots will be less conspicuous.

C. D. JARVIS,
Storrs, Conn.

THINNING

Excessive Bearing

There is the tendency on the part of some trees to overbear, of others to not bear enough. This tendency can, in a large measure, be regulated by pruning, thinning and fertilizing. Whatever tends to excessive wood growth tends to decrease the fruit production, and whatever tends to excessive fruit production tends to small wood growth.

Winter pruning tends to stimulate wood growth and to reduce the number of fruit spurs, therefore to reduce the number of apples. Excessive soil fertilization tends also to excessive wood growth, and therefore to reduce the number of apples. Summer pruning reduces wood growth, multiplies fruit spurs and increases the fruit crop. Root pruning will have the same effect because it retards wood growth. Lack of fertilization retards wood growth and results the same as root pruning and summer pruning of the top.

The remedy is fertilization which will prolong the life of the tree. A tree that bears excessively from year to year is not long-lived. We are generally anxious that our trees should bear heavily, but to overbear shortens the life of the tree, while lack of bearing quality reduces the profit derived from it.

Because of these facts the habit of thinning the fruit to the desired amount has become prevalent, and if the crop cannot be regulated by fertilization and pruning, thinning becomes a very important operation. In fact, a certain amount of thinning is advantageous in any case, because even when the general crop is not heavy two or more apples will form on one fruit spur and so crowd each other that neither one becomes a perfect or marketable apple. It is a good rule to permit but one apple to develop on a single spur. This avoids crowding and at the same time prevents the breaking of the limbs and the necessity for propping the trees.

GRANVILLE LOWTHER

Overbearing in Arkansas

Trees here, especially the Ben Davis, our main variety, have a tendency to

overbear. Limbs which had snapped under the load the past season were often numerous in orchards. The limbs are frequently not removed until the following spring, and in the case of smaller ones often escape attention altogether. Not infrequently examples were seen of fatal fungus diseases attacking such limbs, and passing from the broken to the main limbs. Allowing such limbs to remain is rather a defect of human nature than of practice, as is also the condition which first caused the breaking. Many hold to the belief that a tree ought to be able to carry to maturity all the fruit it sets; and doubtless the basis of this belief is that a dollar in the pocket is worth the promise of two next year. But this is short-sighted. An apple orchard should continue to be a profitable investment for 25 years at least.* Overbearing not only so weakens the trees as to result in "off years" and causes mutilation of the trees and disease, but is particularly trying here where close planting is so common, where supplementary fertilizing of orchards is often neglected, and where trees loaded with fruit have the root louse regularly to contend with, and often "smart" touches of drought thrown in at the time they are heavy with fruit. Aside from this there is a great loss in the proportion of first grade apples. There may be over-production of poor fruit, but hardly of first grade apples where the facilities for transportation to good markets are at hand, and those markets easily accessible. Aside from the demand, first grade fruit tends to increase the consumption and enlarges the market. And lastly, preservation of the "hen that lays the golden egg" is business, and money in the pocket. The proper care and preservation of orchards tends to cheapen the production of first-class fruit, by stopping a number of big leaks, helps the market by enabling us to supply its wants at a reduced figure, with an equal profit to the producer. And such is invariably the testimony of the best fruit

* We think an apple orchard well located, with a deep rich soil, well cultivated, sprayed and pruned, should live and bear for 100 years.—Ed.

growers. As a writer has said, a man can make \$10 a day thinning his fruit.

ERNEST WALKER,
Fayetteville, Ark.

Spraying Results in Needs for Thinning

A new problem promptly presents itself along with the first results of thorough work in spraying—overloading of the trees with fruit. The trees set and persistently retain, oftentimes, twice, thrice or four times the number of apples that they can mature. Where these conditions occur there is no work that will pay better returns than carefully thinning the fruit. A surplus apple or a defective apple should be considered as a “weed apple,” as it will not only be worthless itself, but will prevent the fullest development of the perfect apples which it crowds. It is an excellent plan to relieve overloaded trees by removing the defective apples and thinning those remaining until they hang from six to eight inches apart. The total quantity in bushels, at picking time, will not be appreciably lessened, because individual specimens of the smaller number of apples will attain much larger size.

In addition to the profitable results of thinning, so far as the size and quality of the fruit is concerned, the effect is very beneficial to the trees in various ways, assisting them materially in retaining health and vigor and promoting in a greater or lesser degree a regularity of crop production.

F. H. BALLOU,
Wooster, Ohio.

Will It Pay?

Most mature apple trees have a tendency to overbear and during recent years it has been demonstrated that it pays to remove a half or two-thirds of the apples on all heavily loaded trees. Surplus apples may be regarded as weeds. They are of not much value in themselves and restrict the growth of others. Thinning does not necessarily reduce the yield, but on the contrary greatly increases the yield of first-grade fruit. Besides that of improving the size and quality of the fruit there are several reasons why a tree should be thinned. There is a great drain

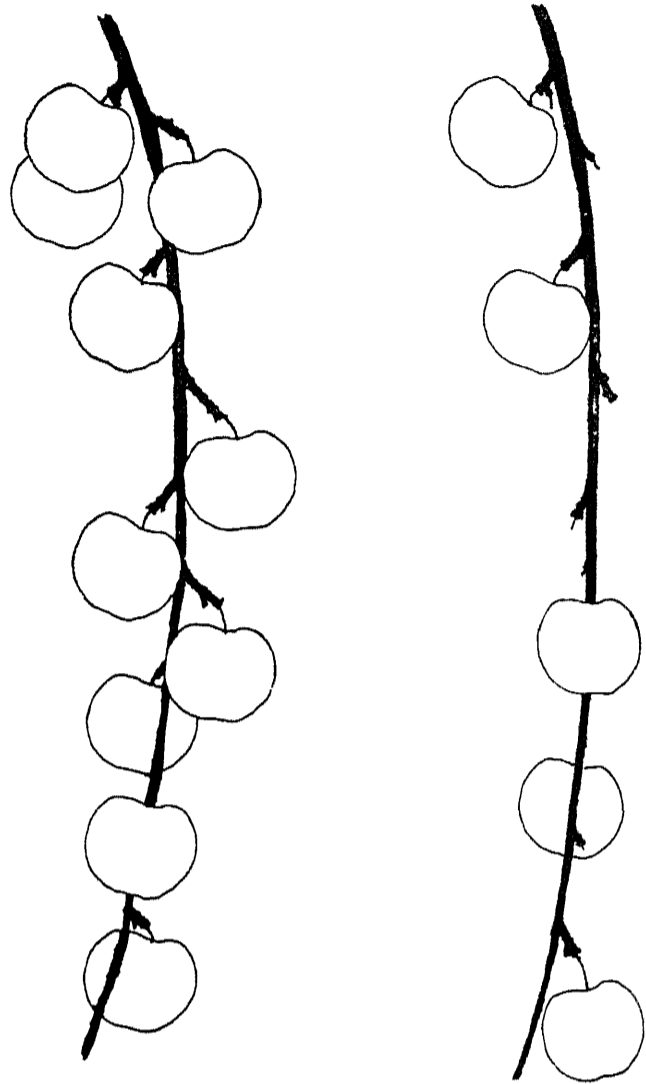

Fig. 1. A Small Branch Bearing Ten Apples. This number should be reduced by half, leaving the apples spaced somewhat as shown in the figure to the right. The same branch after five apples have been removed. These apples were allowed to become too large before thinning.

on the vitality of a tree in the maturing of so many individuals. Each apple has its supply of seeds, and these form the most concentrated part of the fruit. By removing one-half of the apples we relieve the tree of the necessity of maturing half the seeds and in doing so we do not reduce the crop of fruit. By relieving the strain upon a tree during the growing season, the fruit buds for the following year are likely to be better developed, and it is believed also that thinning tends to encourage the annual bearing habit. Thinning lessens the loss from the breaking of limbs and gives the grower an opportunity to destroy insect-infected fruit and thus reduce the number of insects for the following season.

The common objection to thinning is the time it takes. There is no weight to such an argument for there is only a certain number of apples to be picked and

it costs no more to pick them in June than it does in September or October. In fact, it is much easier to do the work at thinning time for the fruit may simply be thrown upon the ground and raked up. A good man should thin eight to ten good sized trees in a day.

When and How to Thin

The work should commence the latter part of June or the first of July. The defective and wormy specimens are first removed. Sometimes the thinner carries a bag over his shoulder for the wormy apples, but this is not necessary if all the thinned apples are afterward raked up and destroyed. The thinner next relieves the crowding. As a rule no more than one apple should be left on a single fruit spur, and those on the tips of the branches usually should be removed, for they seldom make first grade fruit. The result should be that the remaining apples are about six inches apart. Some of the smaller sized varieties may be left closer and some of the larger growing sorts should be given more room. Some varieties seldom need thinning and there are others that habitually overbear.

Thinning the Winesap

The Winesap apple, as a rule, does not (in Colorado) attain sufficient size to meet the requirements for packing in the higher grades. This is especially true of heavily loaded old trees. It is not a "shy" bearer, but has a tendency to bear a heavy crop every year.

Does Thinning Pay?

It often happens that the fruit grower does not like to do a thing unless he is sure that he will get quick returns for his labor. He so often does not look far enough into the future to regulate and manage certain factors over which he may have control that would insure future returns which would more than pay for any extra effort that he might put forth. From this standpoint it is necessary to consider other phases than that of the net returns of a single year, to tell whether or not thinning pays. These may be stated as follows:

1. Maintaining the vigor of the trees.

2. Securing annual crops instead of alternate.

3. To be able to produce fruit of maximum size, color and quality.

Maintaining the Vigor

This is a very important factor, for any fruit tree when injured or impaired in any manner, will not be able so successfully to resist insect, fungus and freezing effects.

Thinning annually and uniformly will have much to do in preserving this vitality * * *

The breaking down of limbs is the result of overbearing and can only be avoided by either propping or pruning and thinning. We firmly believe that props have no place in an orchard and when used are only a sign of very poor orchard management. There is no doubt that pruning has a very important place in orchard management and should not, by any means, be neglected. Especially is this true for the young trees. If a tree is properly pruned every year from the time it is set out, the amount of pruning can be decreased somewhat in proportion to the size of the tree when it has become full-grown. The word full-grown is used more or less arbitrarily, but generally conveys the idea that the tree is capable of bearing a full crop. Some think that every apple tree can be thinned enough with the pruning shears in the winter time, thereby doing away with the necessity of thinning by hand in the summer. These people forget that the plant food that goes to make and mature the apple is manufactured by the leaves and not the roots of the tree. Keep a tree defoliated in the summer for any length of time and you will kill it. It is not best to obtain all of the leaf surface possible, as would be the case with an unpruned tree, for this would mean wood growth at the expense of fruit, and a greater amount of hand thinning. There would also be too much shade for the fruit and a poor color would be the result. A well balanced and well cared for tree, bearing a good crop of uniform sized apples every year will retain its

* E. R. Bennett, Storrs, Conn., Experiment Station Report, 1903

vigor, while a tree allowed to bear an enormous crop one year and none the next may suffer the consequences of over-production.

Securing Annual Crops Instead of Alternate

A tree will produce quantity at the expense of quality, and at the same time utilize plant food that should be used in making the fruit buds for the next year's bloom. The law of Nature is to reproduce its kind and it tends to do it even at the expense of the welfare of the tree. Annual thinning tends to throw a tree into annual bearing. When a tree has been in the habit of bearing alternate crops, it may take some time to induce it to bear

every year by thinning. It has been demonstrated in the orchard where this experiment was carried on that by annual thinning the Jonathan can be made to bloom well every year.

Fruit of Maximum Size, Color and Quality

The total averages, as given in the table found in the different grades, illustrates the points of size and color, for apples have to be of a certain size and a certain color to be packed in the first two grades. The following table illustrates the comparative values of the different grades. The culls were selling at the cannery and evaporator at \$7 per ton, or the equal of \$0.175 per 50-pound box.

	Ex. F. Boxes at \$1.75	Ex. C. Boxes at \$1.50	Standard Boxes at \$0.85	Cull Boxes at \$0.75	Cost of Thinning
Thinned.	5.34=\$9.35	3.07=\$4.61	3.2 =\$2.72	1.11=\$0.19	\$0.64
Unthinned.....	2.5 =\$4.38	1 =\$1.50	9 =\$7.65	5.08=\$0.89	.
Thinned.....	Gain=\$4.97	Gain=\$3.11	Loss=\$4.93	Loss=\$0.70	Loss=\$0.64

\$8.08—\$6.23=\$1.85, total gain per tree.

When trees are set 16x32 feet, there are 85 to the acre. A gain of \$1.85 per tree would make a total gain of \$157.25 to the acre.

This seems strong evidence that thinning the Winesap gives large returns for time and labor expended. The above figures are conservative in at least two respects: First. Many of the windfalls which were counted as culls could never have been sold for any purpose; especially was this true of the early dropped windfalls. Also there is much doubt as to whether the amount received for the culls would have paid for the extra labor required in picking, hauling and sorting. Second. The extra amount of time that it took to grade the apples from the unthinned trees for packing was considerable. These two expenses would alone almost offset the cost of thinning. Uniformity of size was very characteristic of the apples from the thinned trees, while the apples from the unthinned ones were of all sizes.

Better colored fruit was always found

on the thinned trees than on the unthinned, due largely to the fact that the fruit on the unthinned trees was crowded and consequently more or less shaded.

The lessened percentage of wormy apples, due to picking and destroying the apples infested by the first brood of worms, would probably be a saving sufficient to largely bear the expense of thinning.

How to Thin

Study each tree individually and thin so that at picking time the tree will hold up well under a load of uniform, good sized and well colored apples. It takes experience and study to get the very best results from thinning.

The experiment indicates that best results in thinning the Winesap can be attained when the apples are thinned to a distance of from nine to ten inches. It is well to commence at the top of the tree and work down. Perhaps, if there is any difference in distance to be made, it would be better to thin the apples on the lower limbs next to the trunk of the

tree a little farther apart on account of being more shade in this part of a tree. Although some shade is a good thing, as it prevents sunscalded fruit, it is possible to have too much.

A very good type of thinning shears is shown in the cut. Take off all terminal branches on long, slender branches and break all doubles. Take off all wormy apples and all those that are much smaller than the average. Take off all limb-bruised or badly frost marked apples, and also those that are liable to become limb-bruised as they grow in size. Leave the apples in singles and in such a position that they can have the best

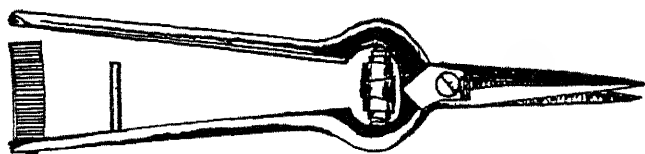

Fig 1 A Good Type of Thinning Shears.

chance to grow in size, color and uniformity, and be as free as possible from blemish.

There is another phase of thinning that would help, and that is the cutting out of every other tree in rows that have the trees so close together that they are crowding each other. Trees, when crowded, are bound to grow upward rather than outward, and if let alone will, in a little while, have most of the fruit bearing wood in the tops. This is truer of peaches, perhaps, than of apples, nevertheless apple trees when crowded cannot do as well as when they have plenty of room. For this reason it is necessary to cut out every other tree in the row, or the alternates in every row, this depending on the way and the distance the trees are set.

Conclusion

1. That thinning of the mature Wine-sap tree pays in money returns the first year.

R. S. HERRICK,
Fort Collins, Colo.

FERTILIZATION

Limiting Factors

1. Fertilizers are but one of many factors that affect success in orcharding. Among the others are soil, location, vari-

eties, cultural methods, thinning, spraying, pruning and general orchard care.

2. The weakest factors largely control and limit the crop and through them it can be affected. Consequently the value of attention to any factor is essentially proportional to its need. In general, therefore, applications of plant food will be of most value when it is the limiter. In the presence of other still weaker factors its effect may be wholly lost.

3. The best orchard treatment probably consists in the discovery of crop-limiters, their elevation to the level of the other factors, and the maintenance of a properly balanced treatment thereafter.

4. The recognition of plant food as a limiter is often difficult and the fact is best determined by trial. Its need, however, may be indicated by the trees being deficient in growth, foliage or fruit after the other factors are apparently right. Under such conditions the addition of manures and fertilizers has yielded most abundant results.

5. Nitrogen is apparently of much greater value in apple orchards than is generally supposed. Its addition has greatly increased the quantity of fruit. Many failures with potash and phosphates have doubtless been due to a deficient nitrogen supply. It should be used judiciously, however, because of an indirect reduction in color, and sometimes also in size of the fruit. It can be used most freely on the earlier soils or in localities with long growing seasons.

6. Nitrogen may be secured in stable manure, cover crops, or in commercial forms. If applied in very soluble forms, especially on leachy soils, the time of application must be right. This is probably somewhat after petal-fall, when the stored food is exhausted and the need is greatest.

7. In general, where plant food is needed, phosphate and potash should also be supplied. This prevents their becoming limiters in turn, and may also check some of the ill effects of nitrogen on the appearance of the fruit.

8. Both lime and "floats," when applied alone, have thus far failed to show any marked beneficial effects.

9. None of the fertilizers applied in

our work have shown any consistent ability to improve color or size of fruit. Color is doubtless chiefly dependent upon maturity in sunlight, while average size is apparently mainly dependent upon the amount of moisture available per individual fruit.

10. Our present general recommendation of fertilizer for apples in this state, in amounts per acre, is the following combination: 30 pounds of actual nitrogen, 60 to 75 pounds of actual phosphoric acid (P_2O_5), and 50 pounds of actual potash (K_2O). This may well be supplemented by cover crops, through which all the nitrogen may be obtained, and alternated with stable manure at the rate of about 10 tons per acre at least every third or fourth year.

11. Proper moisture conditions are essential to the securing of best results from fertilizers. In most places moisture conservation is best accomplished by the soil or dust mulch maintained by frequent tillage. Where tillage is advisable, it can also be done very satisfactorily with a good mulch of foreign materials, such as straw, chaff, leaves, manure or dead weeds.

12. Leguminous crops apparently make less draft upon soil moisture than the grasses or cereals. This, together with their favorable nitrogen relations, makes them decidedly preferable to the latter in apple orchards, whether used as intercrops, cover crops, or permanent covers in connection with a mulch.

13. Accompanying the fertilization

above, a good plan of soil management for many situations is tillage with a leguminous cover crop while the orchard is young, followed by a mixed grass and leguminous sod-mulch when bearing age and size is reached. After the bearing habit is established, a return to tillage at least every second or third year should be made, increasing the frequency of tillage with the age of the orchard and the demands of the fruit.

14. Current orchard practice may be improved by the owners adopting the methods apparently best for their orchards as a whole, and then maintaining some parts for experimentally determining whether the methods chosen are really best for their conditions.

JOHN P. STEWART,

The Pennsylvania State College Experiment Station.

Soil Constituents Removed by the Apple

One of the most natural questions which arises when considering the subject of fertilizing an orchard is, What soil constituents are removed by the apple and in what proportions? An answer to this question, together with an analysis of the particular soil under consideration, will give the clue to the fertilizing needs of that particular orchard.

Composition of Fruit

The general composition, viz., the percentage of water, organic matter and ash which make up the whole, and the amount of nitrogen, are given for the four varieties examined in the following tabulated form:

Name or Variety of Apple	Water	Organic Matter	Ash	Nitrogen
Duchess of Oldenburg.	88.61	11.14	.25	0382
Wealthy.....	87.00	12.71	.29	.0375
Fameuse.....	85.22	14.46	.32	.0512
Northern Spy.....	87.08	12.65	.27	.0445
Average.....	86.98	12.74	.28	.0428

Percentage of Important Constituents in Ash

Name of Variety of Apple	Phosphoric Acid	Potash	Soda	Oxide of Iron	Lime	Magnesia	Silica
Duchess of Oldenburg	8 90	53 67	3 28	1 77	5 80	5 20	36
Wealthy	8 15	57 00	2 65	1 76	3 33	3 84	63
Fameuse	7 19	56 25	2 56	1 26	3 55	4 03	32
Northern Spy	11 68	54 11	1.94	2 13	3 86	3 99	1 11
Average	8 98	55 26	2.61	1 72	4 38	4 27	60

In this table the composition of the ash in detail is given. Of its components, phosphoric acid and potash are the principal. The latter constitutes over half of the ash (55.26 per cent), while the former is about 9 per cent, the average being 8.98 per cent.

No great differences between the varieties are here to be noticed, though the Northern Spy presents some striking variations from the average. Its ash contains nearly 3 per cent more phosphoric acid, nearly 1 per cent less soda, about .5 per cent more silica than the ash of the other apples.

The ratio of the potash to the phosphoric acid in the ash of the fruit is 0 to 1; in the ash of the old leaves it is 2 to 1. Relatively, therefore, the demands of the leaf and the fruit on the soil of

these two constituents are very different. It might here be remarked that the greater quantity of the ash ingredients of the fruit is contained in the seeds and walls of the ovary, comparatively little being found in the flesh of the apple.

A comparison of this table with that showing the composition of the ash in the leaf, will reveal further interesting features. The total percentages of ash in similar weights of leaf and fruit, are as 3.46 to .28. Lime is much more abundant in the ash of the leaf, while magnesia, oxide of iron and silica are about the same, taking the older leaves for comparison.

For the purpose of a practical presentation of the subject, the data presented in the following table have been prepared:

Weight of Important Fertilizing Constituents Withdrawn from the Soil

Name of Variety of Apple	Average weight per bushel in pounds	Nitrogen		Phosphoric Acid		Potash	
		Lbs. per barrel	Lbs. per acre, or 160 barrels	Lbs. per barrel	Lbs. per acre, or 160 barrels	Lbs. per barrel	Lbs. per acre, or 160 barrels
Duchess of Oldenburg	44	.046	7 359	.027	4 307	162	25 975
Wealthy . . .	50	.057	8 220	.032	5 181	.226	36.232
Fameuse	50	.070	11 223	.031	5 043	256	39.456
Northern Spy .	46	.056	9 006	.039	6 383	.185	29.570
Average	47 5	.057	8 952	.032	5.228	217	32.880

Note.—In the above calculations the following data are used: Forty trees per acre in an orchard 25 years old yield, on an average, one hundred and sixty (160) barrels. One barrel contains two bushels and three pecks.

We have here the number of pounds of nitrogen, phosphoric acid and potash estimated as contained in one barrel of the fruit, and the amounts removed per acre by a good crop. None of the quantities are at all excessive, and the cost of returning them would not be great. The largest demand is on the potash in the soil; next comes the nitrogen, and lastly the phosphoric acid. In the case of the leaves, the nitrogen stood first.

For the vigorous development of the tree and an abundant crop of fruit, the soil must contain these constituents in a more or less *immediately available condition*. It is for this reason, as well as to replace the exhausted plant food, that fertilizers are necessary to profitable apple growing.

Nitrogen

To supply nitrogen, some organic manure is perhaps the most economical. Barnyard manure or the turning under a leguminous crop (the latter being rich in nitrogen) are to be recommended. Besides adding nitrogen, they furnish humus or decaying vegetable matter, which serves a useful function by liberating carbonic acid, and which in turn sets free locked-up forms of mineral food. Humus, moreover, has much to do in bringing about good tilth and in the retention of soil moisture. As the period of growth and fruit development in the apple is comparatively long, organic manures in most instances will probably give better returns than those containing more soluble forms of nitrogen, such as nitrate of soda or sulphate of ammonia.

Potash and Phosphoric Acid

To furnish potash and phosphoric acid, we would first mention wood ashes. In many parts of the country they are the cheapest form in which to purchase these constituents. Moreover, they possess them in the relative proportion best suited to

tree requirements and in a condition that renders them easily available

If wood ashes are not obtainable, kainit and muriate of potash may be substituted to supply potash; and bone meal and superphosphate, the phosphoric acid. Bone meal contains two per cent to three per cent of nitrogen, in addition to the phosphoric acid, but requires a greater length of time in the ground to give up its constituents; its effects naturally last longer. For this very reason it is often advocated for orchard fertilization.

Both wood ashes and bone meal furnish lime, which we have seen to be a necessary and somewhat important element.

Soils differ so much in composition that it is impossible to state definitely the amounts of these fertilizers that should be employed in all cases. The wants of the tree for fruit and leaves have been given and the principles for an economical return of these requirements indicated. In conclusion, it may be said that the best and most profitable crops can be obtained only when the soil contains what might be thought to be a large amount of plant food, the greater part of which is more or less assimilable. A good tilth, among other advantages, tends to a good root development. In such the rootlets are able to procure food from a much larger area than otherwise; but in every orchard, owing to the disposition of the roots, there must of necessity be much unoccupied soil, and hence the importance of supplying liberally and in excess of that which is absolutely needed for a season's growth and fruit, those forms of plant food which we have been considering.

About 200 pounds of ground bone and 200 pounds of muriate of potash, applied annually to bearing orchards should furnish an abundant supply of phosphoric acid and potash.

Leaves in proportion to their weight contain a much larger amount of plant food than the fruit. The amount contained in 1,000 pounds of leaves gathered in September was 8.87 pounds of nitrogen, 1.94 pounds of phosphoric acid, 3.92 pounds of potash, this being the average of five varieties analysed.

Although there is a great similarity in composition in the varieties examined, and none differ much from the average deduced from them all, it is of interest to note that the Fameuse is the richest in organic matter, in ash constituents and in nitrogen. The Wealthy and Northern Spy contain almost identical amounts of organic matter and ash, and the Duchess of Oldenburg has the largest percentage of organic matter and ash.

F. T. SHUTT,

Chemist of the Dominion Experimental Farms

Sign of Need

As to the indications when a bearing orchard needs stimulating, the eminent pomologist, Doctor Warder, once said: "When the growth of the terminal branches fails to make an annual extension of at least one foot in length, the tree should be stimulated by manuring the land and giving it thorough cultivation."

For Young Orchards

The young orchard will require just enough feeding to keep it growing, and the amount of manurial elements applied should increase in proportion to the size of the trees. It is difficult to give any definite information on this point, for so much depends upon the character of the soil, the method of management, and the character of the crops grown between the trees. For the first year, just after planting, about two ounces of nitrate of soda and two ounces of muriate or sulphate of potash may be scattered around each tree, and a general application of about 400 pounds of basic slag and 300 pounds of raw ground bone per acre, scattered over the whole area. The following year the basic slag may be omitted and the nitrate of soda and sulphate of potash doubled. The third and subsequent years, if a cover-crop is turned under and the trees are making satisfactory growth, the nitrate of soda may be omitted and a general application given consisting of 200 pounds of sulphate of potash and 300 pounds of raw ground bone, to the acre. If at any time the cover crop should fail, an application of about 100 pounds to the acre of

nitrate of soda may need to be applied. It is believed that in the past too much attention has been given to the use of nitrogenous fertilizers for young trees, and that if more attention is given to the mineral elements the trees are likely to commence bearing earlier. The use of lime has also become necessary on many soils, and for this reason an occasional application of basic slag, which contains a large proportion of lime, may be substituted for the raw ground bone.

While these suggestions and recommendations concerning fertilization may prove valuable for certain soils and conditions, there are undoubtedly many special cases where such advice would be of no value and may be entirely misleading. On many soils heavy applications of any one element of plant food may be unnecessary. A soil that fails to respond to the application of any particular kind of plant food, is probably well supplied with that element. For these reasons, each grower should determine by experiment the peculiar fertilizer requirements of his soil.*

Feeding the Apple Tree

Of all the intricate problems relating to orchard management, that of feeding the apple tree is probably the most perplexing. To a large proportion of the New England farmers this problem has never presented itself, for they have assumed that the orchard did not require fertilization. The specialized apple growers are just coming to realize the peculiar fertilizer requirements of the apple and the importance of ascertaining the fertilizer requirements of their various orchard lands.

Elements Needed

In general, plants require three elements of plant food, and the apple tree is no exception. These elements are nitrogen, potash, and phosphoric acid. While not usually considered a necessary element of plant food, which must be supplied, lime is of much benefit to most crops and its value should be considered when buying fertilizers. If these ele-

* Or send sample of soil to state chemist for analysis.—Ed.

ments are not in the soil in available form they must be applied. It is not only necessary that they be present in the soil, but they must be in a soluble form, for in such form only can plants make use of them. Some kinds of fertilizers dissolve readily when applied to the soil. There are other kinds that become available gradually and some others that are so nearly insoluble that most plants cannot make use of them. The apple, being a long lived crop, can make use of the slow working fertilizers, but the tendency among careful apple growers is to use soluble fertilizers and apply them just when needed. The experienced apple grower who keeps a close watch of his trees will probably get best results from soluble fertilizers, but the average farmer will do well to adhere to the use of fertilizers that become available gradually.

C. D. JARVIS,
Storrs, Conn.

Bearing Orchards

The fertilizing of bearing orchards seldom receives adequate attention. Bearing trees in the crops removed make heavy drafts on the elements of plant food in the soil. The most important elements which are removed are nitrogen, potash, and phosphoric acid. Roberts*, in an experimental study of the question, found that allowing 35 trees to an acre, and a yield of 15 bushels to a tree, the plant food removed in 20 crops of apples, and the leaves for the same period amounted in round numbers to 1,337 pounds of nitrogen, 310 pounds of phosphoric acid, and 1,895 pounds of potash. Comparing the amounts used with those required by ordinary wheat crops (15 bushels per acre and 35 pounds of straw), for an equal length of time, the apples removed practically three times the quantity of potash, half again as much phosphoric acid, and twice as much nitrogen.

The roots of a tree are constantly extending over a larger area, but it is plain that if we would maintain our trees in the best condition and improve the aver-

* Roberts, "Soil Depletion in Respect to the Care of Trees." Cornell Experiment Station Bulletin 108.

age size of fruit from year to year, we cannot neglect attention to this matter.

The tendency of increased feeding, especially in connection with thinning of the fruit, would be to do away with "off years," and reduce the damage due to insects and fungi. It is a noticeable fact that vigorous trees do not suffer from the attacks of these organisms as much as those which have been more or less enfeebled from some unfavorable condition or circumstance. In good soils trees will get along for some years, but after bearing begins it is only a few years before the trees will begin to feel the need of plant food to compensate for that removed. Of these nitrogen is most cheaply supplied by means of good tillage and the judicious use of green manures, like cowpeas, and winter covers of vetch and rye. Diminished growth and paleness in the color of foliage are to a considerable extent guides in determining the need of nitrogen. Frequently too much dependence is placed on the virtues of legumes to the exclusion of applications of other fertilizers. Excess of nitrogen should be avoided. There should be a balanced "ration." In the case of bearing trees applications of potash are called for; also of phosphoric acid. Cowpeas do not increase the supply of these elements as they do of nitrogen.

Stable Manures

Practical men report excellent results from the use of stable manures. There is no objection to their reasonable use on apples. Commercial fertilizers may supply the same manurial elements in less bulk and with relatively greater profit. But especially on the lighter soils humus is needed, so it is well to make use of all the methods of supplying the elements needed. A good plan would be to let an application of stable manure—20 to 25 tons per acre—take the place of legumes once in four or five years. Whether the leguminous crops are kept up annually in the interval will depend on the needs of the trees. An application of 50 to 100 pounds of nitrate of soda per acre just before the growing season might be desirable under conditions where there

is an immediate need of nitrogen. This element is mostly needed early in the season to provide for a good growth of branch and root and abundance of foliage. An excess, especially late in the season, tends toward continued growth and late maturing, and poorer color in the fruit.

Quantity Needed

In case dependence is placed on the commercial forms of potash and phosphoric acid, the conditions will ordinarily call for at least 200 pounds of ground bone, 100 pounds of Carolina superphosphate and 100 to 200 pounds of muriate of potash. The amounts mentioned would ordinarily prove moderate applications. The potash may be increased to 400 or 500 pounds per acre without injury, but of course large amounts must not be placed immediately about the roots, especially near the trunk. The commercial forms of potash and phosphoric acid tend to produce a firmer wood than stable manures, or natural fertility, and this means less tenderness under winter conditions. The application should commonly be made previous to a plowing when it will be mixed with the soil. Fertilizers on the surface, if slowly soluble, have a tendency to invite the feeding roots to the surface. To reduce the effects of drouths to the minimum the plan from the start would be to encourage a deeper root system, which early plowing, fertilizing and subsequent tillage will encourage if thoroughly done.

ERNEST WALKER,
Fayetteville, Ark.

Soil Balancers

We know what it means to have a balanced ration of human food. No matter how good an article of food may be, if the individual is compelled to eat that and nothing else, he not only tires of it, but it is impossible for him to maintain on that food alone a good degree of health.

This has been discovered to be true in the feeding of stock, and it is a common remark among the breeders of poultry that hens in order to lay large quantities of eggs must have a balanced ration. The same is true of vegetable life.

The elements necessary for plant growth must be in proper proportions if the plant is to thrive.

Some soils act as balancers for others.

It is known that clay is a fertilizer for sandy loam, that is, the clay when added to the sand improves the soil by making a balanced ration, thus fertilizing it. Sand will also fertilize a clay soil. In like manner, it will fertilize a boggy soil, a gumbo or an adobe soil, and in turn the boggy soil will fertilize the sand or the clays of the upland. A soil rich in humus will fertilize both sand and clay, while gypsum is a good top dressing for alkali soils, and alkali is a fertilizer for soils deficient in the alkali substances. Alkali is a fertilizer up to a certain point, after which it becomes injurious.

The proper balance of food substances for the different kinds of vegetables and fruits may be hard to determine, but in his ability to discover this balance lies the difference between the ordinary farmer and the one who succeeds in the highest degree.

GRANVILLE LOWTHER.

Manufactured Fertilizers

There are many kinds of manufactured fertilizers, some of which are valuable only for special soils or special crops. It is difficult to determine what fertilizer it is best to use without knowing what elements are lacking in the soil. The three elements most commonly needed by soils are nitrogen, potash, and phosphoric acid; and chemical fertilizers that contain the largest percentages of these substances in available form will be the most valuable.

A fertilizer containing 1½ to 2 per cent of nitrogen, 7 to 9 per cent of available phosphoric acid, and 10 to 12 per cent of potash will give excellent results when applied to orchard land in quantity ranging from 400 to 600 pounds per acre.

Fertilizer Formulas

It is a difficult matter to formulate any rule for the fertilization of apple orchards. Briefly stated, the manurial recommendations are dependent upon the age of the trees; the vigor, as indicated by the annual growth; the nature of the

varieties; the character of the soil; the cultural system employed; the kind of cover crop; the kind of filler used; the nature and amount of other crops grown in the orchard; the availability of fertilizing materials; the severity of pruning; the size of the expected crop; and, to some extent, the character of the season. The formula mentioned below should be taken as a suggestion only, and should be modified to suit special conditions.

For mature apple trees on soil that is apparently in need of a complete fertilizer the following formula is suggested:

Nitrate of soda (15 per cent or its equivalent) 200 pounds.

Muriate or sulphate of potash (50 per cent potash or its equivalent) 250 pounds.

Raw ground bone (20 per cent phosphoric acid and 3 per cent nitrogen or its equivalent) 400 pounds.

These amounts are intended for the annual treatment of one acre of orchard land.

Soil Analysis

The soil constituting the proposed orchard site should be carefully studied, and if found to be lacking in the essential elements of fertility necessary to maintain a fairly vigorous wood growth, fertilizers should be added before plowing, that they may become thoroughly incorporated with the soil in preparing the land for planting.

Scientists and practical orchardists are generally agreed on the great value of well-rotted barnyard manure for an apple orchard. It not only supplies humus, but it contains a large per cent of other necessary nutritive elements for maintaining health, vigor, and fruitfulness of trees and for the development of the proper qualities for a fine fruit product. But as the stock of this sort of manure is not always sufficient for the general demand, other agents have to be resorted to; and next in value and in a concentrated form are unleached wood ashes, which will supply, to a great extent, the elements necessary to plant growth. It is maintained by some authorities that one ton of unleached wood ashes contains as much plant nutriment

as five tons of ordinary barnyard manure; therefore, whenever obtainable, ashes should be used in preference to any other fertilizer.

G. B. BRACKETT,
Washington, D C

Stable Manure

Stable manure is the standard fertilizer of the diversified farmer and the stock raiser. The commercial fruit growers, however, rarely use this form of fertilizer in their orchards. The chief objection to its use is that it is relatively rich in nitrogen, which becomes available late in the season. The liberation of nitrogen late in the season is likely to keep up growth so late that the trees will not ripen their wood properly before the arrival of cold weather. Stable manure is a complete fertilizer and, when applied to the soil, supplies in addition to the three elements of plant food, a large amount of vegetable matter. For this reason it is well suited to the enriching of vegetable gardens and corn fields.

C. D. JARVIS,
Storrs, Conn

PICKING APPLES

There are two important questions on picking apples. One is, when to pick, and the other is, how to pick. When to pick depends largely upon the time of ripening and whether the apples are to be used for the local market or shipped to a distant market. If they are to be used for the local market, they may be left on the trees longer than if they are to be shipped a considerable distance, and in remaining longer on the trees will become more highly colored, more fully ripened and more highly flavored. A general rule is that the apple is ready to pick when the seed is brown. At this time the apple, according to this theory, is supposed to have reached its full growth and development, and after that the changes which occur in the direction of the ripening or the breaking down process will go on as well off as on the tree. Some orchardists, however, depend more on the color of the fruit than on anything else. An expert can walk through an orchard and tell when looking at the trees, without

particularly examining the seed, as to when the fruit is ripe enough to pick. Some apples begin to fall as soon as they are ripe, and should be picked before they fall, because they are damaged in falling. A little observation and experience will teach persons at what time the different varieties of apples should be picked.

The second question is, how to pick. There are various mechanical devices for picking. They are generally unsatisfactory. Our observation is that picking should be done by hand, and that the hand should be carefully guided by intelligence so that the fruit may be picked at the right time and without bruising or breaking the skin. Generally, there should be more than one picking, since the apples ripen irregularly. At a time when one-third of the apples which are the earliest in developing, are ready for picking, perhaps another one-third should hang on the trees several days longer, and another one-third longer still. In order to obtain the best results, have the largest number of well-colored, well-flavored, and well-developed apples, it is better to have two or three pickings. This costs more, but it more than pays the extra cost in the increased value of fruits. It is especially important to have pickers trained, if apples are to be shipped and sold in fancy markets at high prices. Pickers should be trained so that they can pick the apples without bruising them, without denting them with the finger nails, without breaking the skin by pulling off the stems, and without pulling the fruit spurs from the tree. If the fruit spurs are pulled off, there will be no more fruit on those spurs.

Considerable controversy has arisen as to what is the best vessel to use in picking. Baskets with padding on the bottoms to prevent bruising, can be used, but they have been found to be somewhat cumbersome. Buckets are better, because it is easy to fasten them with hooks to the limbs of the tree, and thus be free to pick with both hands. Some use the ordinary galvanized iron pail. Others use a bucket with a canvas bottom so devised as to open at the bottom, allowing the apples to roll out without injury. Picking bags or

aprons are also in use. These bags are so arranged as to swing around the neck, hanging down in front. They can be opened at the bottom for emptying the fruit without bruising. They are held open at the top by a wire so that it is easy to place the apples in them. They are closed at the bottom by a flap which folds up and is fastened to the side by means of a hook and a ring, so that it is easy to empty them into the boxes in which the apples are hauled from the orchard. It is better to haul the fruit boxes on low-wheeled trucks or on sleds and to empty from the boxes on to assorting tables with

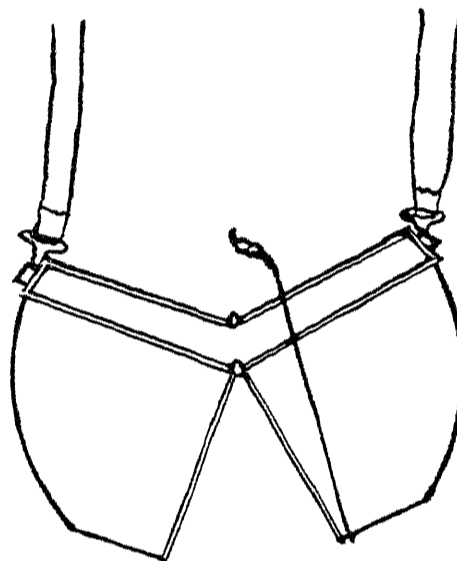

Fig 1. This form of Picking Bucket is carried over the neck by a strap which is further equipped with a hook which may be used for hanging the bucket to a limb or the picking ladder. The bucket is designed to be placed with its load in an apple box. A catch is released which allows the bucket to part at the bottom, permitting the apples to roll out into the box without bruising.

tops made of canvas. In case assorting machines are used especial provisions are made to prevent bruising. If apples are to be kept for the best markets, too much care cannot be exercised to prevent bruising, and pickers should be trained to know how to do this work in the best way. If apples are bruised the keeping quality is impaired; if the stem is pulled out or the skin broken, fermentation and decay begin very soon. Bruised apples, or apples with the skin broken, belong with the culls, and very often apples that are otherwise of the very best quality and would bring the highest price in the market are thrown into the "cull pile" because of a little carelessness or indifference on the part of the



Fig. 2. Scene on Thompson Fruit Ranch Showing Type of Bucket Used for All Kinds of Fruit.

picker. Perhaps no work in the orchard requires the exercise of more care and good judgment than the work of picking.

A low step-ladder to be used in picking the fruit just out of reach of a man standing on the ground and another tall enough to reach the upper branches of the large trees will usually be sufficient. Various types are illustrated. The tripod or three-legged type, is by far the best adapted to average conditions.

GRANVILLE LOWTHER

Time to Pick

Picking is one of the most important phases of getting the apple upon the market. It has a marked influence upon the keeping qualities, color, size and flavor of the fruit. Too much attention is frequently given to getting depth of color, and, as a consequence, over-ripeness, caused by the fruit hanging too long upon the tree, is very often the result. The time of picking is influenced very markedly by the variety, climate, soil, elevation, shipping

distance, and season. Apples may be divided, according to their condition at maturity, into several different classes.

Among the apples that drop when they are ripe, we may mention the Grimes Golden, Wagener, Wealthy and Winesap. Other apples that drop before they are ripe are such varieties as the Gravenstein, McIntosh and Snow. Many apples that hang too long on the tree develop core rot, and we find that the Jonathan, Gravenstein, Delicious, and Ortley come under this class. Others, if they hang too long, get mellow or soft after picking, and have a short season of consumption. In this class we would include such apples as Jonathan, King, and Baldwin. Some varieties, such as Early Harvest, Duchess, Red Astrachan, and the Jonathan are troubled with cracking at the calyx. On the other hand, there are varieties like the Spy and Ben Davis that may hang after maturity before picking. Summer apples should be picked green for shipment. They should have some

color, but should not be soft. These varieties drop badly if too ripe. The grower himself must be the judge of his local conditions of season, soil, shipping distance, and the like.

The time of picking has a marked influence upon the color of all apples. The

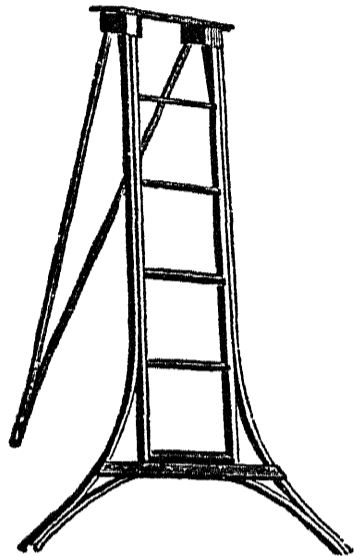

Fig. 3. "Eclipse" Orchard Ladder Having an Especially Wide Base. A low ladder like this may be used for gathering the fruit from the lower limbs

yellow and green colors change after picking but the reds change very little. With many varieties it will pay to make several pickings; especially is this true of red and striped varieties. The increase in size and added depth of color gained by leaving the immature fruit for a second picking more than repays the grower for the additional trouble. Summer apples usually attain their best flavor upon the tree, but late fall and winter apples are better some time after picking.

Most of our commercial varieties of pears, if allowed to mature on the tree, become granular, and also have a tendency to develop core rot. In order to have juicy, fine and smooth grained fruit, it is necessary to harvest the pear while it is still hard and green. The most common practice has been to recommend that the pear be severed from the tree as soon as the stem will separate easily from the spur by giving the wrist a gentle twist. In some cases it is recommended that the pears be picked when they reach a certain diameter. With some pears, at least, it will be found advantageous to pick the fruit over an extended period. The Bartlett, for example, can be picked over a

period of six weeks, and where an extended period like this is allowed, the total weight of the fruit gathered from the trees is very materially increased.

Occasionally pears are picked by clipping the stems with scissors or knives. This is done in order to place the fruit on an early market and thus reap a fancy price. If the fruit is picked too early, however, it will be very insipid, and tend to shrivel; it will have a tendency to scald; and the texture will be leathery. As concerns the Bartlett pear, recent investigations conducted in the Rogue River valley by the United States Department of Agriculture have shown that it is better to allow the pears to hang from ten days to two weeks longer than is now the common practice; that when this is done the fruit becomes larger, develops a better quality, and keeps better.

Picking Operations

One of the first lessons a foreman must give a picker is to tell him not, under any circumstances, to bruise or puncture the skin of the fruit or to rub off fruit spurs or injure the tree in any way. If the fruit is bruised or punctured it soon decays, and thus losses which are attributed to

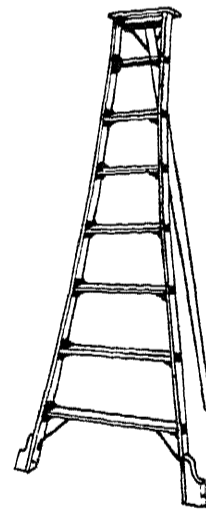

Fig. 4. A Strong Type of Orchard Ladder. Special claims are made for this ladder on account of the fact that no nails are used in its construction. A tall ladder like this or similar type is useful in gathering fruit high up in the tree.

the commission man are often the fault of the fruit grower himself.

The organization and distribution of labor is always a problem of orchard management. In picking, it is usually advisable to divide the pickers into crews, giving to some of the older men and to

the women and girls the job of picking from the lower branches, which they can reach from the ground or from short step ladders. The fruit on the upper branches can be picked by another crew working on taller ladders.

The ladder should never be leaned into the tree if it is possible to avoid it. Fruit



Fig. 5. Portable Orchard Ladder, Folded.

spurs often cover the ground under such conditions, and not only is the crop for the succeeding year damaged, but openings for disease are left in the tree itself. The act of picking is a very simple one. A simple twisting movement up and down on the fruit removes it from the spur without loss of stem, and this easy removal is usually a fair indication of the maturity of the fruit. There are some special varieties, notably the Ortley apple, which very often, though mature, break their stems and puncture the fruit, if not carefully handled. The stem may be broken without hurting the salability of the fruit but should never puncture the skin or be pulled out of its socket.

Picking Pails

The receptacle selected for picking should prevent all bruising, as far as pos-

sible, and should give ease in handling. Theoretically, it would seem that bags or canvas bottom pails would be the best for picking, but, practically, such is not the case. There is a bad tendency among pickers to let the fruit fall into the receptacle and, unless this fruit can be heard by the foreman as it falls, there is no way to prevent consequent injury. Bags allow the fruit to be damaged by not protecting it against bruising when coming in contact with ladder or tree. When the bottomless bags are used the pickers very frequently will allow the fruit to shoot into the field box when emptying, thus causing damage.

A galvanized pail about ten inches high and narrow enough to fit down into the apple box when it is emptied, so that the apples can be poured into the box very carefully without bruising, is a good one for this purpose. Such a pail should have a hook attached to the bail for hanging on the ladder or tree limb. Several so-called bottomless pails have been constructed of galvanized iron, or tin, which allow the fruit to be emptied into the bottom of the box and the pail to be lifted without rolling or bruising the fruit. Some of these pails have merit, and, where not too expensive, should be money-savers for the grower. In the case of peaches and plums and other stone fruits, shallow pails or baskets should be used, as these fruits bruise easily when piled one upon the other to any depth.



Fig. 6. Portable Orchard Ladder Ready for Use. The running board enables the picker to cover a wider range than would be possible with the ordinary step ladder.

Ladders

There are many different types of ladders, some of them very awkward and clumsy. A ladder should be light and easily handled, braced strongly, and so constructed that it will not tip over easily. All joints should be tight so that there will be as little wobble to the ladder as possible. For picking the lower parts of the tree the short step-ladder, three or four feet high, and made rigid, is good. For lighter work, the tripod step-ladder is fine. It combines lightness with ease of operation, and is also very strong and solid. In some sections the so-called Japanese tripod ladder is used to quite an extent. Other ladders, such as the rail ladder, consisting of a single strong stake with a wide base and rounds projecting from it, are used for very high work. In the East the wire apple picker is sometimes used to pluck some of the very highest apples growing in the center of the tree; but in the Northwest these pickers have been needed very little as yet because our trees are lower.



Fig. 8. The Japanese Ladder.



Fig. 7. Another Type of Portable Orchard Ladder which enables the picker to get close in to the tree without breaking the branches or bruising the fruit.

—*Courtesy Woods & Soule, Payette, Idaho.*

Picking Boxes -

The picking or lug box should preferably be somewhat larger than the packing box, in order to keep it separate from the latter. This size also has the advantage of holding about a packed bushel of apples. The box should have slits cut in the ends so that the fingers may enter for lifting the box, and these ends preferably should be higher than the sides so that as one box is set upon the other there will be no jamming of the fruit.

Some orchardists have a very light portable stand which pickers working on the ground among the lower branches take with them for setting the picking box on. The picker then does not have to stoop to deposit his fruit in his box, and bruising is minimized.



Fig. 9. Picking Scene in Rogue River Valley. Showing type of orchard ladders, picking buckets and lug boxes in use in the orchard of Mr. W. G. V. Campbell. The picking bucket is the canvas bottom type.

Orchard Trucks

Orchard trucks should be low for ease in loading; should be easy riding; and preferably should have a cross reach so that the rear wheels follow in the track of the front wheels in turning sharp angles.

C. I. LEWIS,
Corvallis, Oregon.

Date of Picking and Size of Apples

H. H. Braggins, of Cashmere, Wash., has made some experiments in picking in which he reaches the following conclusions: "There has been considerable talk about picking the largest and best Jonathan and King David apples from the 18th to the 28th of August in order that the apples remaining on the tree may have a better chance to grow larger. I had doubts if it would be profitable for several reasons, provided the apples were properly thinned in June. One reason was that it costs two to three times as much to pick a box of apples where you only pick one here and there, as it does where you can pick them all in one or two pickings. Another reason is that you are liable to bruise and mar the apples, more or less, that are to remain on the tree. This bruising is done mostly with

the ladder. On August 18, I had a number of apples measured, a tag tied on the stem of the apple and the date and circumference written on it. When we picked the apples we measured them and marked the results on the tag. We found that the Jonathans averaged a little more than $1\frac{3}{8}$ inches in circumference more than when first measured. The Rome Beauties measured $1\frac{3}{4}$ inches more than when first measured.

"The Winesaps averaged a growth of $1\frac{7}{8}$ inches more. It will be noted that the later varieties made the largest growth, because they had from one to three weeks longer to grow. Apples that will pack from 138-163 per box in August with a growth of from $1\frac{1}{4}$ to $1\frac{3}{8}$ inches larger later in the season, will bring 15 to 25 cents per box more. Does the apple remaining on the tree have enough greater growth to make up for the loss on those picked early?"

The grower in this case would not only have more boxes of apples on account of the larger size of the apples but he would have apples which are worth more per box. If there were no loss from falling apples to counterbalance these gains, it would pay to leave the apples on longer.—Ed.

PACKING OR PREPARING APPLES FOR MARKET

FRANK S. KINSEY

PACKAGES

As in marketing other farm products, two methods are used in marketing apples. One is handling in bulk, where, if any receptacle is used, it is retained by the seller; the other, handling in packages which go with the apples, constituting "gift" packages. The present extensive use of the latter method is the result of modern transportation and storage facilities, which have made the apple a profitable article of commerce. Whatever qualities a successful apple or other fruit package may possess, it must have cheapness, neatness, lightness, a certain amount of durability, and uniformity. Three forms of package are in use for apples—the basket, the barrel and the box.

Basket

The basket can be used successfully only for home markets, and for apples that are to be sold for immediate use, such as summer apples. The style of basket most used in New York state contains approximately a bushel; is tall, narrow at the base, and flaring wide at the top. A style used to a great extent in the Middle states holds approximately one-third of a bushel and is rectangular in shape. These baskets are standard packages for many of the fruits and vegetables in the sections where they are popular. On the Pacific coast the basket is not used for even the summer apple, the box or half-box taking its place.

Standard Barrel

The United States standard for apple barrels as established by the enactment of the "Sulzer" bill in 1912, calls for the "length of stave, 28½ inches; diameter of head, 17½ inches; distance between heads, 26 inches; circumference of bulge, 64 inches outside measurement, representing as nearly as possible 7,056 cubic inches." The law further provides that "barrels packed with apples shall be deemed to be below standard if the barrel bears any state ment, design, or device indicating that the barrel is a standard barrel of apples," as to size, and the capacity of the barrel is less than the capacity indicated above, "unless the barrel shall be plainly marked on end and side with the words 'short barrel,' or with words or figures showing the fractional relation which the actual capacity of the barrel bears to the capacity prescribed by * * * this act." And, further, that such "marking required shall be in block letters of size not less than 72-point, one-inch gothic." The penalty for selling or offering for sale apples in barrels in violation of the provisions of this act is \$1.00 for each barrel sold or offered for sale.

The legal apple barrel in the state of New York has the same dimensions as the United States standard, except that the distances between heads or the cubic capacity are not specified. Provision is made that if the barrel is straight on

the side, or without a bulge, it shall contain the same number of cubic inches as the standard barrel. The standard apple barrel as adopted by the International Apple Shippers' Association in 1895 is the same as the New York standard. The legal apple barrel in Virginia has been: head diameter, 17¼ inches; length of stave, 27½ inches; bulge, not less than 64 inches outside measurement. The minimum dimensions of a legal barrel in Canada are: 26½ inches between heads; 17 inches diameter of heads; 18½ inches diameter of middle, all inside measurements. This barrel, in common use in Nova Scotia, is made of 28-inch staves. The barrel in use in Ontario is made of 30-inch staves. Its dimensions are: between heads, 27½ inches; head diameter, 17 inches, middle diameter, 19½ inches.

Barrel Specifications

The specifications for a good apple barrel call for a sound stave, nine-sixteenths inch jointing, cut five inches to two inches and averaging four inches in width at the bulge. The head to be not less than one-half inch in thickness, dressed, and the barrel to have eight hoops. The material preferred is elm.

Standard Box

Several unsuccessful attempts have been made to establish a national standard apple box in the United States. The proposed "Porter" box was to contain 2,564 cubic inches, the "Lafean" box, 2,343 cubic inches. Three sizes have found favor sufficient to establish them as standard in certain sections. The "Colorado" box, which is used mostly in Colorado and Utah, measures 11½x11½x18½ inches, and contains 2,261.625 cubic inches. The Canadian, or "special," box measures 10 inches deep, 11 inches wide and 20 inches long, and contains 2,200 cubic inches. The "Northwest Standard" box is 10½ inches deep, 11½ inches wide and 18 inches long, and contains 2,173.5 cubic inches. All the foregoing dimensions are inside measurements. The bulge on the top and bottom, with which it is customary to pack a box of apples, adds, it is usually figured, about 150 cubic inches to its contents. A struck Winches-

ter bushel contains 2,150.42 cubic inches. The Canadian national apple box is obligatory for the export trade. The Colorado box was designed originally for the "jumble" pack; the Northwest standard and the special, for the "layer" pack. "The committee of the Northwest Fruit Growers' Association on the matter of securing uniform apple packages, reported to the meeting at Portland in 1901 in favor of using only the 'standard' and 'special' boxes. At the meeting the following year at Walla Walla the association reaffirmed by resolution the adoption of these sizes, and urged all members to use the same."* Up to this time there had been great confusion in the matter in the Northwest. Even as late as 1904 Mr. Maxwell Smith, Dominion Fruit Inspector at Vancouver, found no less than seven different sizes of apple box in the Seattle market. The only boxes now used in the American Northwest are the standard and the special, and even the latter has all but gone out of use.

Northwest Standard Box

This was legalized in the state of Washington in 1903 and in Montana in 1913. Two objections have been raised against this box. The first, from some Eastern fruit dealers, who are used to the barrel as the unit of measurement for apples, who believe that three boxes of apples should fill one barrel, and who variously state that it takes from three and one-eighth to three and one-quarter boxes of packed apples to pack one barrel. The other objection comes from some growers and packers in certain districts of the Northwest, and is one which they would still urge against any box, viz., that no one box is suitable for all counts of apples, sized after the manner of the Northwest. The answers usually given to the first of these objections are: (1) it is not necessary for the contents of a box to be a denominator of the contents of a barrel; (2) the packed box makes a heaped bushel, as can be seen by pouring the apples from a packed box into a

bushel measure; (3) this is the only requirement which is founded on good reason; (4) the box apple is a product entirely different and separate from the barrel apple, and not to be considered or confused with it; (5) the inconvenience and confusion which would arise among the packers of the Northwest at any change in the package to which 10 or 15 years of use has accustomed them, would offset any inconvenience to the dealer in not being able to think always in denominations of the barrel. Where the objection takes the form of a complaint that the Northwest Standard box does not contain a heaped bushel, or four pecks, the trouble is usually not with the box, but with the pack. If it cannot be done through rules of associations and contracts of dealers, legislation should enforce a firmness and fullness of pack, and a minimum weight for a box of each of the commercial varieties.* As influenced by the variety and size, a properly packed box will weigh from 45 to 55 pounds gross. As to the second objection, namely, that the Northwest Standard box is not suitable for all sizes of apples, the elimination of the "square" pack and the adoption of the 113 and 125 counts of the "diagonal" pack, together with the favor with which the new system has been received by the trade, has demonstrated beyond a doubt the lack of necessity for the two box system. It should be stated that, whatever the size of an apple box, it should not be disproportionately long or narrow in shape. One will be impressed with this fact if he makes the rounds of the produce district in the city of New York contiguous to Pier 20, where the Northwest Standard is dubbed the "chunky" box, and is preferred to the special. The latter box, although really containing more cubic inches, looks smaller, because slimmer.

Box Specifications

The standard specifications for the apple box call for three-quarter inch ends, three-eighths inch sides, and one-quarter inch tops and bottoms. Thinner ends

* Note, page 7, University of Idaho Agriculture Experiment Station Bulletin 54, 1906, Lowell B. Judson, Picking, Packing, and Marketing the Apple.

* See Canadian Fruit Marks Act. Sec. 6. under Law.

split too easily, thinner sides endanger the good condition of the fruit; likewise thicker tops and bottoms, by lack of pliability for the bulge. It is important that the lumber come up to these specifications. No little complaint came from the trade, both domestic and foreign, during the season of 1911, on account of the flimsiness of much of the material in the boxes sent out from the Northwest. For export, the tops and bottoms are frequently double, with the swell not greater than the thickness of the box cleats. One-piece sides are used, and two-piece tops and bottoms, all of which are a little narrow, thus furnishing ventilation. A cleat three-eighths of an inch thick and three-quarters of an inch wide is used on either end of the top and bottom, nails being driven only through the cleats. In the East some boxes come with the tops and bottoms already cleated. Six or eight 5d. or 6d. cement coated box nails are used on each side, eight on the bottom, and eight on the top. The larger size of nail is to be recommended, also eight to the side.

A few panel ends are offered both in the Northwest and the East; but they are objectionable, because they prevent handling with the clamp truck and do not make so neat and strong a package.

Spruce has been the material usually recommended. It imparts no disagreeable flavor to the apples in storage, and is easier to secure clear of knots. It splits more easily than pine, however, in making up, unless green. The ignorant purchaser is also likely to have hemlock sold to him for spruce, which former is cheaper, splits even more easily, and is even rougher, if not surfaced. The Yakima Valley Fruitgrowers' Association purchases pine for its members, finding that it makes a better looking box, holds nails more firmly, and does not split.

Mr. A. V. Stubenrauch, pomologist and horticulturist in the Department of Agriculture, says:

"Regarding the absorption of flavors by fruits in cold storage, I would state that so far as our experience has gone, we have not found that apples stored in pine

boxes absorb the flavor of the wood to any deleterious extent. We have found fruits affected by foreign odors in storage rooms, but these have been largely flavors or odors of highly pungent or strong natures. The temperature at which the fruit is held does not seem to affect this property of absorption to any great extent. For example: We have found that apples stored at 32 degrees in a room in which peppers were held absorbed the pepper flavor and odor to a marked degree."

"Fire killed timber" is "almost odorless and does not impart an unnatural flavor to the fruit"* Some boxes offered in New York state are made of gum.

Apple boxes cost in the Northwestern states from 9 to 11 cents; in Colorado, from 12 to 13 cents; in New York state, about 12 cents; in the Virginias, from 13 to 18 cents.

Box Making

"Box shooks" are usually hauled to the packing house and made up on the spot. To perform this operation rapidly [by hand] make a form by nailing two cleats a foot long on the work bench, just the length of a side board apart, and about seven-eighths of an inch inside each of these nail another, thus making two slots to receive the end boards. In the same manner cleat a short board and nail it on edge just back of the cleats on the bench, meeting them at a right angle.

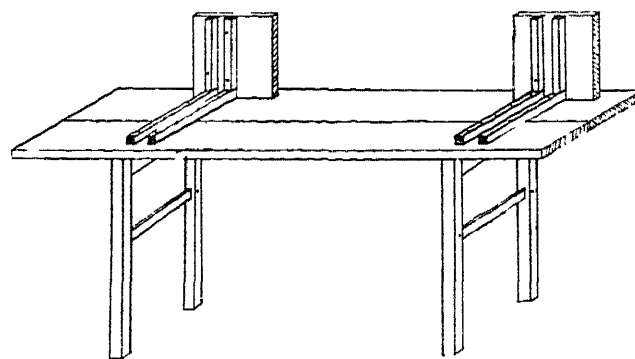

Fig. 1 Box Form for Making Apple and Pear Boxes.

End boards thrust into these slots are thus held upright while being nailed. Instead of the upright cleats at the back of this form, some prefer to arrange two sets of arms made of short boards a few inches above the bench to engage the box

* Outlook, Vol. 101, p. 665, 1912.

ends and keep them from wobbling. First one side board is nailed to the ends, then the bottom, then the other sides. If the box cleats split in nailing, they can be soaked in water previous to using. A nail stripper is a necessity. It will cost between \$4 and \$5. One of rather poor make can be seen attached to the box press in Fig. 26. A new self-feeding stripper is on the market at \$6, its automatic feed resulting from the jar of the bench to which the stripper is attached as the nailer pounds. An experienced nailer can make 40 boxes an hour. One cent a box is usually paid for making.

Barrel Versus Box

The barrel and the box are the two packages suitable for use in long distance shipments and in storage. The barrel is distinctively an Eastern package, and the box a Western. One reason for this is that hard wood suitable for making the barrel has been cheaper in the East, and soft box wood cheaper in the West. The Western growers have also been forced to put out a package more uniform in quality and size of fruit, in order to compete with Eastern growers in Eastern markets, under the disadvantage of higher transportation charges, and this end has been more readily gained by the use of the box.

For the Barrel

The barrel, however, has some advantages over the box as a package for apples. It can be packed well with less skill, and more rapidly. It can be handled more easily, by rolling, than any other package for equal bulk. Until recently it has been a cheap package; although "it now costs most fruit growers from 30 to 40 cents instead of 15 to 30 as formerly." Also, "many varieties export better in the tight barrel, not permitting entrance of salt air into the package."*

For the Box

The advantages of the box are: first, that its small size is more suitable for use as a carrier for some soft varieties

of apples; because when so many are placed together as in a barrel, they will, when they mellow, bruise from their own weight. Second, "the box holds a more convenient quantity of fruit for the 'ultimate consumer,'" being especially adapted to the use of "the average city person who wishes to buy only such a quantity of fruit as will keep at the ordinary temperature of the home, while it is being used."° Third, the smallness of its size in itself induces the customer to believe that the quality of the contents is such as to make up in value any lack of quantity. Fourth, it is better adapted for use as a display package. Dress an apple box with a white lining on its inside and lithographs on its ends, taking care that the others of its whitewood surfaces are smooth and spotless; then note the result. A barrel at an apple show—an extreme case, to be sure—looks incongruous. Also, the use of the box practically forces a uniform size and attractive arrangement of the apples themselves, and renders easy the securing of an intense effect of color by the opportunity afforded for massing the boxes solidly.

Question of Economy

After all, however, the matter of whether it is better to use boxes or barrels, will have to be decided by considering the economic conditions in the locality of the producer and the standards and possibilities of the market to which the apples are sent. "The barrel has been the standard and practically the only package for winter apples for over half a century." The objections to the use of the box in the East, besides that of cost, are: "The average [Eastern] grower cannot grow a crop of fruit of high quality varieties yielding around 90 per cent 'Fancy,' or No. 1. Skillful and experienced packers are not obtained in these sections. Scarcely any grower is able to put a large quantity of box fruit on the market year after year, thus establishing a reputation for his brand. The average market does not take kindly to the Eastern packed box. (I think they are becoming educated.)" On the other hand, it can be said that the use of the

* E. W. Bailey, University of Illinois, in Report of Illinois State Horticulture Society, 1910. ° Ibid.

box in the East is increasing. Expert packers from the Northwest are being employed by various organizations of the East to teach the growers the science and art of apple packing, and information on the subject is being disseminated by the agricultural colleges. Prof. E. W. Bailey goes so far as to say, "The trend of the times in all commodities is toward the smaller type of package, and the box package will doubtless sometime supplant the barrel." It is generally conceded in the East, however, that at the present only the best grades of apples will pay there in boxes, and by some it is believed that only then is the use of the boxes feasible under the direction of a co-operative association, with its trained manager and crew of expert packers.

There are some who believe that the growers of the Northwest will, with the increasing output of the section, be forced to the use of the barrel for the cheaper varieties and grades. This, it is believed, will come about, first, because of a shortage of labor. It requires less time to pack apples in barrels than in boxes, using the Northwest methods. Second, because of a necessity of reducing the packing expense, in order to market the fruit with a profit, with the decline in price which these persons expect, somewhat in proportion to the increase in volume of output.

Problem of Labor

As to the first point, that of the coming scarcity of labor, it is in reality one of the serious problems now before the fruit growers of the Northwest. But little thought has been given to its solution, and no steps taken toward future relief. A few possible methods are here outlined, although no one method will probably be sufficient by itself. Transient labor at its best is inexpert and irresponsible, and at that is far from being plentiful. If it must be employed, however, it can be placed under foremen, provided the latter are available; and the supply can be increased by advertising and by concessions in transportation charges. An available resident population outside the fruit industry that would be sufficient to care for the crop during a short space

of time means a load upon the community during the remainder of the year, unless other industries are established that will absorb it after the harvest season and that can afford to run short or shut down during the fruit rush, while at the same time under this system the fruit industry will not receive the benefit of any great efficiency in its workers, which can come only from practice. However, this system is better than none—in fact, such a system is already practiced to some extent. It may pay to foster seriously these other accommodating industries.

The most satisfactory solution is one that will enable a large part of the work to be done by responsible and expert help. It is encouraging that at least three methods can be suggested to accomplish this end. One is a reduction in the size of large orchard holdings, thus placing a larger population in the industry itself. This is of course impossible without maintaining a certain amount of profit in the production. Another is the employment of all possible machinery to take the place of hand labor, and to set a pace for the workers. There is no work at which a man can waste more time than that of grading entirely by hand. If he has a sizing machine to feed at the same time that he is grading for quality, his eye and fingers may develop twice their usual speed. A third, and perhaps the most satisfactory method, will be to prolong the packing season. The Northwest apple growers are fortunate in at least three respects: the plantings of apples have been mostly of late-keeping sorts; the successful cold storage of apples is an established fact; nature covers the apples in this section with an unusually heavy coating of wax, which makes it possible for them to be stored in many localities without refrigeration. Elsewhere in this work is urged the necessity of picking at the proper time and of rushing the apples into some proper sort of storage, if their keeping qualities are not to be impaired. This method would seem, then, to lie in sending all help possible into the orchards in order to pick at the proper time; to store loose; and then to pack up as ordered, or at leisure. Briefly stated, store at home

loose, rather than at the market packed. A certain number of men who will thus be employed during the fall and winter can be used in the orchards in early spring for pruning and during the remainder of the year for spraying, irrigating, and the other orchard labors.

Problems of Expense

As to the point of expense, many deny that an increased production necessarily means an overproduction and resultant decrease in price. Others believe that even if the price of apples is to be lower, it would not be a menace to the industry, but rather a benefit by increasing demand, provided that means of reducing proportionately the cost of growing and marketing are employed. They further believe that the reduction in the cost of marketing is not to come through the replacing of perfect, though comparatively costly methods of packing by imperfect, though cheap methods, but rather through the employment of co-operative packing and co-operative and direct buying and selling; and that the reduction in the cost of production is to come through the dissemination of knowledge and the employment of more efficient methods in orchard management. As to the disposal of the low grade of apples, if it is not profitable or for other reasons is not advisable under the present methods employed, it does not necessarily follow that the barrel is to be used. The expense of putting out a box with a jumble pack would be not far from the expense of putting out a like amount in the barrel, and by many the box for this purpose would be preferred. Many would dispose of any apples that are not profitable when packed according to the Northwest method, by turning them into by-products before placing them before the public, thus avoiding any lowering of the standard by which the Northwest apple has become known. Others would find a limited market for such grade in certain sections of the West, where the apples could be sent in bulk loose in the car. This practice would save at least \$90 on the expense of each car put out.

In some instances Western box apples that have not met a ready sale in the

East, have been transferred into barrels and disposed of at a profit. This is not an argument in favor of the barrel, however, as in such cases, if the grade and pack have been up to standard, it will usually be found that the consumer has not been accustomed to the box; frequently because he has looked upon it as an article beyond the reach of his purse. The remedy for this is a campaign of education of the retailer and consumer, and a reduction of the cost to him through the use of the means indicated above. One fact is certain: wherever Western box apples have been introduced, the result, so long as the standard of grade and pack have been maintained, has been an increasing demand.

BARREL PACKING

Grades

The United States standard grades for barrel apples as established by the enactment of the "Sulzer" bill in 1912, governing the shipment of apples in interstate commerce and the sale of apples in the District of Columbia or the territories, is as follows: "Apples of one variety, which are well grown specimens, hand picked, of good color for the variety, normal shape, practically free from insect and fungus injury, bruises, and other defects, except such as are necessarily caused in the operation of packing, or apples of one variety which are not more than ten per centum below the foregoing specifications shall be 'Standard grade minimum size two and one-half inches,' if the minimum size of the apples is two and one-half inches in transverse diameter; 'Standard grade minimum size two and one-fourth inches,' if the minimum size of the apples is two and one-fourth inches in transverse diameter; or 'Standard grade minimum size two inches,' if the minimum size of the apples is two inches in transverse diameter." Provision is also made that if "the barrel bears any statement, design, or device indicating that the apples contained therein are 'Standard' grade and the barrel fails to bear also a statement of the name of the variety, the name of the locality where grown, and the name of the packer or

the person by whose authority the apples were packed and the barrel marked," the barrel shall be deemed to be misbranded, and the negligent person or persons shall be liable to a fine of one dollar for each barrel concerned.

The requirements of the International Apple Shippers' Association for "No. 1" apples, as adopted by that body in 1895 (amended 1897) are as follows: "The standard size * * * shall not be less than two and one-half inches in diameter and shall include such varieties as Ben Davis, Willow Twig, Baldwin, Greening and other varieties of kindred size. The standard for such varieties as Romanite, Russet, Winesap, Jonathan, Missouri Pippin * * * shall not be less than two and one-quarter inches. And further, No. 1 apples shall be at the time of packing practically free from the action of worms, defacement of surface or breaking of skin; shall be hand picked from the tree, a bright and normal color and shapely form." The following determining what a No. 2 apple shall be, was adopted by the same body in 1900: "No. 2 apples shall be hand picked from the tree. Shall not be smaller than two and one-quarter inches in diameter and of fair color for the variety. The skin must not be broken nor apple bruised, and must be practically free from scab and other defects. This grade must be faced and packed with as much care as No. 1 fruit."

Grading and Packing Table

The table shown in Fig. 2 is adapted for use either in the orchard or the packing house. "The table in the illustration is six feet long by four feet wide, side eight inches high. Slats in the bottom of the bed are one inch square and are spaced one inch apart. The legs at the lower end are 39 inches long, allowing the bottom of the bed to clear the top of the barrel. The legs at the upper end are 45 inches, giving a six-inch pitch to the table. The apples can easily be inspected as they roll into the apron and imperfect ones thrown out. When the apron is filled it can be slowly lowered into the barrel without bruising the fruit. This packing table may be mounted on

wheels for convenience in orchard work or may be built larger with two funnels allowing two barrels to be filled at once."*

This table, without the bed and sides padded, would not be tolerated in the apple districts of the Northwest. It should be used with a piece of burlap or carpet spread over it that can be shaken frequently to remove the litter, rather than with a slat bottom to allow the twigs and leaves to fall through.



Fig. 2. Grading and Packing Table for Barrel Packing.

West Virginia Experiment Station Bulletin 139.

OPERATION OF PACKING

Facing

In packing a barrel of apples, the package is faced, in order to increase its attractiveness. By facing is meant the placing by hand of one layer or more, frequently of two, into the bottom of the barrel, the intention being that when the package is ready for market the bottom shall be marked and considered as the top. To the end that this facing shall present a really attractive appearance, each apple is laid with the stem end down, the stem having been previously cut off with a stemmer; the apples are selected for uniformity of size and color and freedom from serious blemishes and are arranged regularly in concentric circles. The facing apples should as nearly

* W. H. Alderman, West Virginia Experiment Station Bulletin 139, 1912.

as possible represent the contents of the barrel.

"Care should be taken to select fruit that will just fill up the circles without leaving any spaces or requiring any to be placed on edge. When the center is reached it should be filled with either one, three or four apples (figs. 3 and 4). Never use a large or small apple to fill out the center space as it would spoil the looks of the whole face. By selecting apples measuring three to three and one-eighth inches in diameter the outer circle may be filled with fifteen apples, the second ring by nine and three will fill the center (fig. 3). The next smaller size that can be used measures two and three-quarters to two and seven-eighths inches in diameter. It will take seventeen of these to fill the outer circle, eleven to fill the second and four to fill the center (fig. 4). A size of fruit intermediate between these two could not be used. Many growers face all their barrels using only these two sizes. In case the fruit runs smaller than either of these two sizes one must select that size which will make three circles and leave the center to be filled with one apple. In the case of very large apples like Fallawater they may be arranged in two circles with a space in the center to be filled with one apple."*

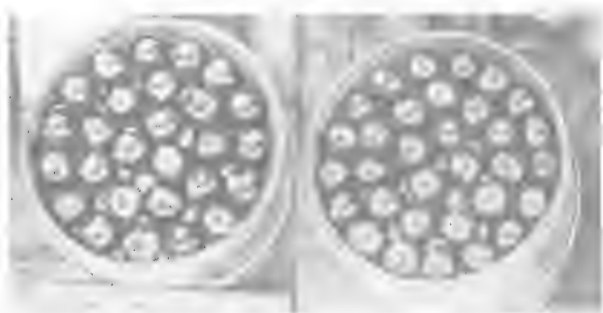

Fig. 3.

Fig. 4.

Fig. 3. Arrangement of the Face When the Apple Runs from Three to Three and One-eighth Inches in Diameter.

Fig. 4. Arrangement of the Face When the Fruit Measures Two and Three-quarters to Two and Seven-eighths Inches in Diameter.

Filling, Tailing, Heading

"The filling of the barrel should be accompanied by vigorous shaking after every half-bushel of fruit has been added.

* W. H. Alderman, 1912, West Virginia Experiment Station, Bulletin 139.

This settles the fruit into its permanent place so that there will be no loosening and rattling after the barrel is packed. When the barrel is nearly filled the upper layer must be arranged by hand to form a level surface against which the head may press. This operation is known as 'tailing.' The barrel should be filled an inch or more above the chime to

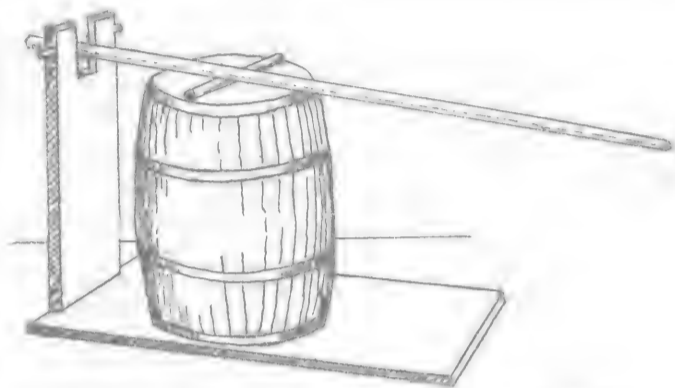

Fig. 5. A Good Home-made Lever Barrel Press.

allow for shrinkage and to tighten the fruit in the barrel when the head is pressed into position."* "The exact pressure which must be given will depend somewhat on the variety of the apple.

. . . The Spy has to be pressed very moderately, as the apple splits readily under pressure; Russets, on the contrary, will stand much heavier pressure without breaking the skin, and appear to require heavy pressure to prevent slackness from evaporation. . . Overpressing will break the skin of the apple, or bruise it severely, inducing decay in one or more specimens, which will quickly cause slackness. . . The process of tailing a barrel of apples is the severest test of a good packer. . . The characteristics of good tailing is to have the apples of the last two rows placed solidly and evenly, so that when finished the head will touch with the same pressure each apple exposed."† "The contents of the barrel are then pressed into place with a well padded head specially prepared for this purpose."** Many, however, dispense with this operation.

There is a difference of opinion regarding the use of pads and decorative paper. "A circle of plain or laced white

* W. H. Alderman, 1912, West Virginia Experiment Station. Bulletin 139.

† Bulletin 19, Dairy and Cold Storage Commissioner's Series, Alex. McNeill, 1907.

** Report Vermont Experiment Station, 1908-1909.

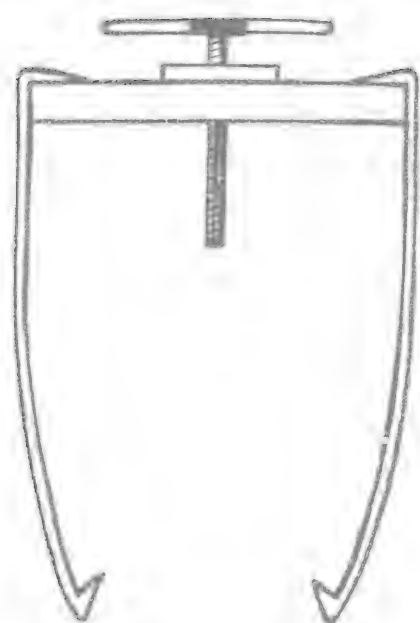

SCREW PRESS FRAME

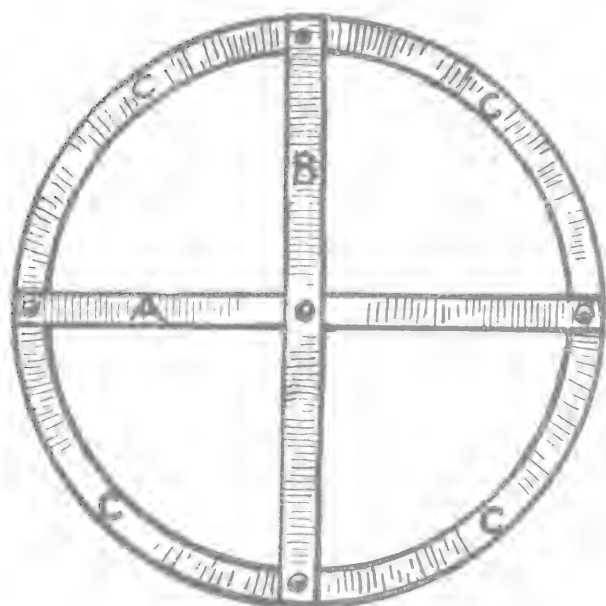

IRON CIRCLE PRESS HEAD

Fig. 6. Screw Press Frame.
Fig. 7. Iron Circle Press Head.

paper placed in the bottom of a barrel before the facers are laid will add greatly to its attractiveness. If in addition a layer of corrugated paper or an excelsior pad is placed under each head it greatly diminishes bruising.* "Heads cut from heavy paper or from light pulp board are very desirable on both ends of the barrel. The patent corrugated heads cannot be recommended. It is doubtful, too, whether there is an advantage in using fancy paper heads." †

In finishing the barrel, six nails driven only through the first hoop to prevent injury to the apples are sufficient. Liners

* W. H. Alderman, 1912, West Virginia Experiment Station. Bulletin 139.
† Bulletin 19, Dairy and Cold Storage Commissioner's Series, Alex McNeill, 1907.

should be used and should be kept damp to make them bend easily and to prevent splitting.

On the head of each barrel should be stenciled the grade and variety of the apple, the name and address of the grower. If the apples are packed in the orchard, the full barrels should not be left in the sun for any length of time before they are transferred to the storage house.

Barrel Press

A screw press frame is shown in Fig. 6. "To make the pressure equal, an iron circle press-head is used, as shown in Fig. 7. The bars A and B are made with an arch and with a shoulder to fit against the iron circle, C. The circle should be 14 inches in diameter and made of quarter-inch bar iron." *

"The lever presses are more rapid to operate than the screw type, which is being used less and less. The iron circle used on some presses to force the head to place is usually in the way of the operator, a single wooden block extending crosswise of the head being far more convenient. An excellent press is shown in



Fig. 8. Press for Heading Apple Barrels.

* J. A. Ruddich, Department Agriculture, Canada, "Better Fruit." September, 1910, p. 39.

Fig. 8. If the press has to be carried about the orchard frequently, it may be made much lighter by turning up the bottoms of the iron uprights in the form of a hook to clamp under the edge of the barrel and discarding the heavy base." °

BOX PACKING

Packing House Necessity

With the barrel as the package, it does not so much matter where the packing is to be done, whether in the orchard or in a packing house, because of the rapidity with which the crop is thus cared for; but in the case of box packing, the question is one of importance. In barrel packing, the important point as to this phase of the question, is to keep the apples cool from the time they are picked to the time the packed barrels are placed in storage, and if this can be accomplished under the protection of an old shed, a canvas awning, or of the trees themselves, nothing more is necessary. In the sections where boxes are used, and especially where wrapping is practiced, the grower will, however, soon find a packing house a necessity. The caprices of the autumn weather will have anything but a desired effect upon the condition of the apples and the temper of the packers, and will often retard the work. A truth not sufficiently recognized is that the comfort of the graders and packers has in most cases a direct bearing upon the quality of their work.

Location

Some growers prefer to build the packing house near the center of the orchard, while others locate it near the exit from the ranch; in either case it is usually in a group with the other farm buildings. A few are fortunate enough to be able to build it against a car siding. This point will have to be determined by each grower for himself, economy of labor and time being the chief points to consider.

Construction

No packing house is complete without two compartments, one for at least tem-

porary storage, and the other for a grading and packing room. Although the majority of the packing houses in the Northwest probably possess but one; due to a great extent to the fact that the necessity of keeping fruit cool and at an even temperature from the time of picking, has not been appreciated. A few persons who have built their storage rooms capable of withstanding winter temperatures and have sold their apples in early spring, have paid for the house in one season by the increased returns from the crop. Where a hillside is available, some such houses are built with a basement of concrete or masonry, the packing compartment being on the upper floor. Where all the second story is not needed for a sorting and packing room, the remainder is used for the storage of box material, for various farm purposes, or is fitted up for additional winter storage. Not every farm possesses a hillside, however, and a large number of the most successful combined packing and storage houses are built on level ground. In the latter case the entire building is usually of wood; and that part intended for winter storage is constructed with insulated walls. Neither the working nor the storage compartment should be so large as to necessitate a waste of steps in handling the fruit, yet they should be planned with reference to future needs. For the sake of convenience the doors between the two compartments should be on the side of the rooms rather than on the end. Every packing house should contain room for the storage of box material, where it can be kept away from the sun, dust and rain. In very dry climates it is well, also, to provide a room for the storage of wrapping paper, where the humidity can be regulated. Dry, brittle paper tears in wrapping and does not handle so easily and rapidly as when soft. A porous brick floor that can be wet will serve for the latter purpose, the paper to be piled on a platform of slats a few inches above the floor. The cost of the packing house will of course depend upon many factors. Some of the newer houses erected in the Northwest represent an outlay of from two to seven thousand dollars

° W. H. Alderman, West Virginia Experiment Station Bulletin 139, 1912.



Fig. 9. Combined Storage and Packing House of J. T. Baird, Riverside District, Mabton, Wash. Note galvanized iron ventilators in concrete foundation. This house has a covered platform on two sides.

Work Room

The important point in the construction of the work room is to furnish good light for the graders and packers. This can be accomplished by a row of windows along the side, by skylights in the roof, or by a combination of both methods. Where side windows are used entirely, a north light will be found most satisfactory, because most even. Packers should not be expected to work in direct sunlight. In large areas of the Northwest apple growing sections it is now possible to install electric lighting in the packing houses, and this should be done wherever possible for use in the late afternoons of dark days. Another point to be looked to is ventilation without draughts that will disturb the wrapping paper. Convenience will be determined to a great extent by the disposal of the grading and packing furniture. Provision may need to be made for heat if the room is to be used in the late fall or the winter.

Storage Room

"Cool" Storage

Several combined packing and "cool"

storage houses have been built in various orchard sections of the Northwest within recent years. The principle of "cool" storage consists in the use of night air for maintaining a low temperature during both night and day.

The "cool" storage room or building is insulated in the same manner as a cold storage room. Three or four inch-thick dead air spaces separated by partitions of moisture proof paper over shiplap are said to serve as well as cork, at the same time being cheaper. Some of these plants, notably in the Payette, Idaho, district, are built with basements to be used for common storage, in which case air is taken into the room above, the "cool" storage room proper, through openings in the walls just above the floor. In one room in the Yakima, Washington district, which room has been built into the basement of a warehouse, the air is taken in through a chute reaching down from the outside and extending along under a false floor consisting of planks laid an inch apart, the air entering the room through these cracks. In the case of two

other rooms in the Yakima district, both built above the ground, the air enters through openings in the foundation walls, and up through a floor built similar to the one in the plant just mentioned. C. I. Lewis suggests that in buildings of this latter type, if the room is large, some of the air should be made to enter through chutes under the floor and reaching to the center of the room, in order to insure a more even distribution of air throughout. Some persons believe that an insulated floor should be laid underneath the ventilating floor; but the bare earth underneath, if it is kept moist, helps to retard loss of moisture from the apples. In order to secure the necessary draught of air through the "cool" storage rooms they are further provided with ventilators in the roof; and where they seem to be most thoughtfully constructed and where electric power is available, fans are installed in the ventilators to increase the draught by suction. Of course the air intakes of the "cool" storage room are furnished with cutoffs, which are closed during the daytime and opened at night.

It is stated that in well constructed rooms, where also electric fans are used in the cupolas, the day temperature can be kept to within two degrees of the outside night temperature. Hence the practicability of the system will be determined largely by the known night tem-

peratures at the time the rooms are desired to be used. "Cool" storage has proved especially efficient for storing apples which mature late in the season, and it may be more or less of benefit in handling any fruit during warmer weather. For the latter purpose, however, it is not a substitute for cold storage or pre-cooling. "Cool" storage is especially adapted for use in arid sections or those of high altitude, where night temperatures run characteristically low. Of course it is a success during injurious winter temperatures, when the air intakes are kept entirely closed and the insulation protects from outside cold.

Sanitation

A point in the care of the packing and storage house, the value of which is frequently unappreciated, is cleanliness. On this point we quote Prof. C. I. Lewis of the Oregon Agricultural College: "There is one point that I would wish to emphasize in handling a packing house, and that is keeping it clean. Some growers allow more or less decayed apples and pears to remain in the packing house months after the crop is handled. As soon as the season is over the house should be thoroughly cleaned. Where decayed fruit has been handled in any way, that portion of the packing house should be washed and fumigated. By writing to the United States Department of Agriculture, bulletins can be obtained



Fig. 10. A Warehouse and Packing House of the Rogue River Fruit and Produce Association, Medford, Ore. Note the excellent provision for light and ventilation.

on handling of fruits, which show from experiment, the necessity of avoiding all possibility of inoculating fruits with decay."*

PACKING HOUSE FURNITURE**

The furniture of the packing house consists of the box machine or box form, the possible sizing and wiping machines or the wiping and grading tables or benches, the packing tables, the nailing press, and the clamp or other trucks for handling the loose and packed boxes of fruit. The box machine has found little, if any, use in the apple industry, owing largely to the fact that it would tie up capital, the benefit from which could be enjoyed only to a limited extent by the average grower. The box form is discussed in this article under the caption of *Box Making*. The clamp truck is a necessity if the packing house is at all large.

* Better Fruit, September, 1910, p. 19.
 ** See also Packing House Management.



Fig. 11. Clamp Truck. Five boxes of apples are handled at once.

Wiping and Sizing Machines

These are of comparatively recent invention for use in the apple industry. The chief obstacle in perfecting them has been the necessity of a construction that will allow absolutely no bruising of the fruit, the extreme tenderness of the ap-

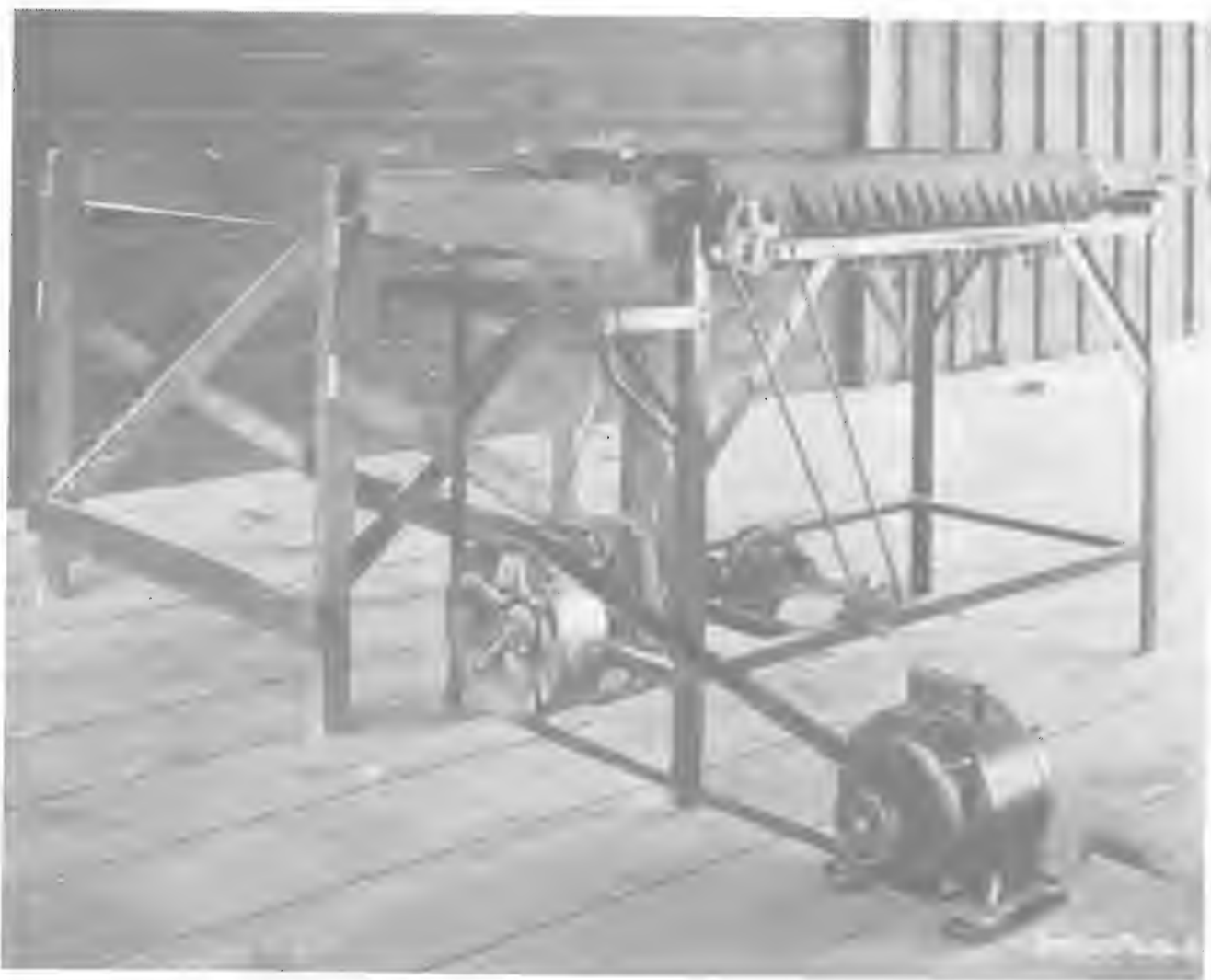

Fig. 12. Apple Wiping Machine.
 Courtesy Enterprise Fruit Machine Co., Zillah, Wash.



Fig. 13. Gilbert Sorting Belt Receiving Trays in Place.

ple, when compared to the orange, having led many to doubt if machinery could ever be constructed so as to handle the apple crop according to the labor saving methods employed with the latter fruit.

The wiping machine is, of course, used only where the apples are coated with an excess of dust or spray. No more wiping should be given an apple than will remove these defacements. Otherwise there is danger of removing some of the wax with which the apple is coated, and which acts as a deterrent toward inoculation with decay. A few persons go so far as to say that apples to be shipped or stored should not be wiped under any circumstance. In this connection, it is well to add that the consumer should be educated to the fact that spray does not render the apple unfit for consumption and that a polished apple means a short-lived apple. A wiping machine, which can be run by hand or motor power, is constructed in the shape of a horizontal

trough, through which the apples pass on a rubber or canvas band, at the same time being slapped by short strips of cloth.

Combination Sorting and Packing Tables

These are great savers of labor, and, unlike the sizing machines, are simple enough in construction to be made by the average orchardist at home. Two types are now manufactured and sold in the Northwest. The Sykes table consists of a tray upon which the apples are sorted, and of various radiating canvas trays into which the apples are shoved directly by the sorters ready for handling by the packers. The use of a belt for carrying the apples in front of the sorters and for delivering the sorted apples into various packing trays was originated by Mr. H. M. Gilbert, North Yakima, Wash., who has operated it successfully for two years at his ranch near North Yakima, Wash.

Mr. Gilbert's machine is simple and in-

expensive, consisting of a slowly moving canvas belt 24 inches wide. The operator shifts the apples on the belt from side to side, and as the apples move along they are pushed gently to receiving tables by curved rods covered with cotton garden hose, lying just above the belt. One table receives the "C" grade, one the "Fancy" and three other tables receive the "Extra Fancy" in three different sizes.

We present herewith descriptions of two sizing machines.

The Price Fruit Sizing Machine

The following statement is from the inventor:

It sizes by weight. The apples are dropped by a pegged wheel into a cup which is attached to an arm, which in turn is moved by a spring, throwing the apples a distance in proportion to their weight, to the proper bins.

It will detect water-cored apples, for they have a greater specific gravity than normal apples, and apples which ought to pack 112 to 125 will be found in bins packing 104.

The apples are not bruised, as they strike soft felt and spring-supported cloth, and roll gently into the bins.

They come into contact with enough cloth during the process to sufficiently clean them for market.

It distributes the apples into 20 bins, each bin containing apples of an exact size used in the Northwest standard pack. The power machine as illustrated handles 1,500 boxes per day. These machines are built in units—one unit forming a small machine capable of handling 750 boxes per day, and two units connected form the large machine. These are interchangeable and can be added at any time.

Jones Sizing Machine

The method of operation of the Jones sizer is as follows:

The fruit is put into a canvas bottomed hopper, from which it rolls down and is spread out before the operator seated at the assorting table, as shown in the large cut. As the fruit is there spread out and rolling over before him, he determines the properly colored and shaped fruit and directs it to the near side of the machine, turning the sound but imperfectly colored or shaped fruit to the far side, and throwing out that which is not fit for packing.

As shown in the small cut, the grading mechanism consists of a series of rubber belts, perforated with round holes of



Fig. 14. Price Sizer and Grader.



Fig. 15. Apple Sizing Machine, Side View.
Courtesy Jones Apple Grader Co.

increasing diameter in successive belts. The apples are guided to roll transversely from the assorting table upon the first belt, and if too large to drop through the grading holes they are guided to roll transversely upon the second belt, and so on to the third belt, and over the end.

Canvas pockets receive the graded fruit and allow it to roll upon the packing tables at sides and end of the machine. From hopper to packing tables the fruit touches only canvas or rubber, and is protected from bruising.



Fig. 16. Apple Sizing Machine, Top View.
Courtesy Jones Apple Grader Co.

Packing Tables

Where neither sizing machine nor sorting table is employed, and where box to box sorting is practiced, two types of

packing table are in use in the Northwest. One has a sagging burlap top to hold the apples loose, the other has an inclined solid or framework top to hold the apples in boxes.

Hollow Top Type

A style of this type frequently recommended is described by Lowell B. Judson, Horticulturist, University of Idaho, thus: "It accommodates two packers and allows free access to the ends for refilling. The favorite size is 3x4 feet, as it allows any part to be easily reached by either packer, and yet holds plenty of fruit, that is, three or four boxes. The full length of the legs is three feet; they come up inside the frame flush with the top, but should be sawed off on a slope inward to prevent the corners bruising the apples through the burlap. The real test of the proper height of the table is the height of the box when in position on the supports; if the packer's extended fingers just touch the lower inside corners of the box as he stands erect before it, the height is correct. Table legs three feet long usually fill these conditions. A board nailed across the end and another running across underneath serve to support the box at a convenient angle for packing. The latter board should, in addition to being nailed, be fastened with wire, or in some equally secure manner, as there is constant and often heavy pressure upon it. Commonly the box supports are arranged at diagonally oppo-

site corners The top of the table consists merely of burlap or canvas

It is an improvement if a double thickness of the cloth is used and the upper tacked at one end only, allowing dirt and litter easily to be shaken off All the apples should be packed off the table about once an hour to prevent bruises wearing upon them. The danger of bruises may also be lessened by edging the table with pieces of hose pipe"* Another style of this type of packing table is one that is long enough to accommodate two or more packers at either side; but this style, because of several disadvantages, is less used. Instead of permanent box supports attached to the table, a more convenient arrangement is secured by the use of a skeleton bench made to accommodate only two boxes, the same to be drawn up alongside the table wherever desired to accommodate either a packer who packs from the right or one who packs from the left This bench can also be built like the one in Fig. 18, with an added incline at the back, to which

the packer can shift his finished box to await the attendant. The revolving box rack sometimes used with the burlap table cannot be recommended, the skeleton bench being more simple

Some persons believe that in packing from a burlap table rather than from an orchard box or another apple box, a pack more uniform is secured, because of the larger number of apples spread over the table from which the packer may select. Also that the very extent to which the apples are spread out on this will save bruises from their being "pawed over" by the packer to find apples of the size that he is packing In working at this table, however, the packer frequently has to reach, not only to his side, but over into the hollow of the burlap, or behind him for the fruit, and, especially at the double, or continuous, style of this type of table, the large sheet of apples that is spread out beside him, rather than being a benefit, sometimes but helps to confuse him, so that he will be seen to fumble over all the apples he can reach, while perhaps the one closest to him is the one he needs Many growers have

* Idaho Experiment Station Bulletin 54, 1906

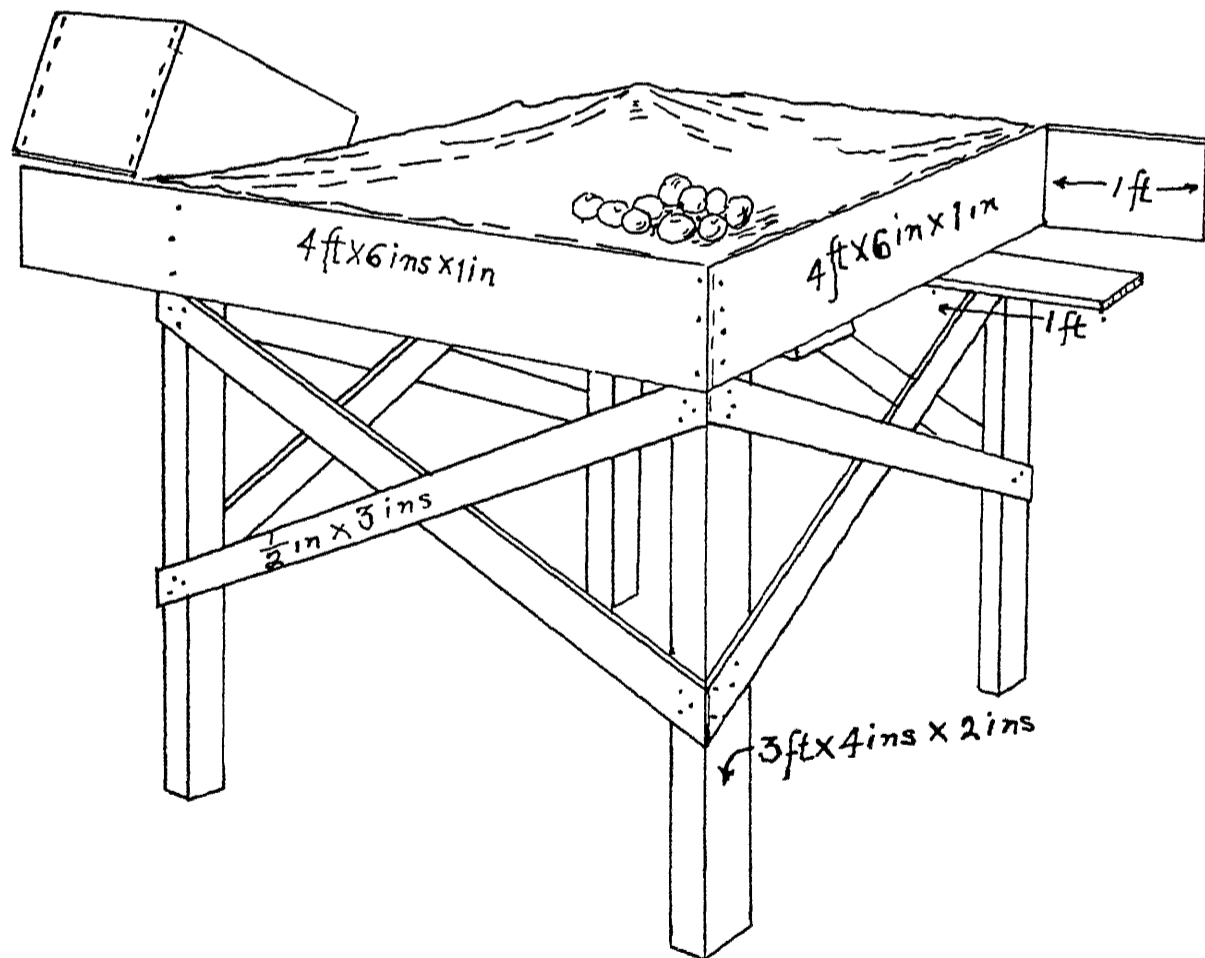

Fig. 17. Burlap Packing Table. Three Feet is Wide Enough.
New York, Cornell, Experiment Station Bulletin 298.



Fig. 18. Table and Bench in Use by Mr. J. H. Estes, Zillah, Wash. Note the shelf for wrapping paper above the boxes, the shelf for cardboard and extra wrapping paper underneath the burlap table, the rack for lining paper attached to this table, and the front incline to the packing bench, to which the packer can shift his packed box to await the attendant. The arrangement shown is for one right handed and one left handed packer.

never used the burlap table because of the danger of the apples becoming bruised by dumping so many of them together and by their tendency to huddle in a pile in the center. This objection, it may be stated, cannot be urged against the system provided for handling the apples in connection with some of the sorting machines, and in connection with the combined sorting and packing tables. Here only one box at a time is poured out, there is no pile of apples which these can strike in a lump, and a sheet of cloth held over the top of the box can be used to keep the apples from rolling from the box all at once. This cloth cannot be used in pouring upon the burlap table, because of the difficulty of extricating it from the pile of apples; while with the use of the machine or the combination table the apples are rolled along to the belt or other part before the cloth is again picked up. The shallow taut canvas or padded trays from which the apples are packed in the use of certain

of the machines prevent the heaps such as are formed by pouring upon the burlap tables, allowing the apples to collect only in a thin sheet; and these trays can be set at such a slant as will cause the apples to roll toward the packer, though gently and without bumping.

Bench Type

Packing from box to box, rather than from burlap table to box, certainly can cause no bruising from pouring. The packer must have more boxes into which to pack, however, in order to prevent his "pawing" at the apples, from four to six boxes being not too many in most cases where no sizing is done before the apples reach the packers. Still this is no disadvantage. The packer can pick up any apple as he comes to it, put it into the box containing apples of the corresponding size, and know that he will not have to consider it the second, fourth or sixth time in making a selection. However, if a machine or a combined sorting and



Fig. 19. Apple Packing Bench. Paper Rack in Place.

packing table is used, on which the apples are moved directly from the sorting section to the packing trays, there is a saving of two handlings over the system of sorting from box to box and then packing either from box to box or burlap table to box. Especially in cases where the apples have to be trucked any distance in handling in the packing house, it is likely to pay to sort only so fast as to supply the packers, even at the expense of storing along with the grades what culls are not detected and dropped in the orchard.

The bench type of packing table is made about two and one-half feet high in front and three feet high at the back. This may be too high for some packers; but many of them find that they experience less fatigue if they stand upon a board with a slight spring to it, or even a hard cushion, and this will bring them into proper relation with the top of the table. The top of the bench needs to be only so wide as the distance between the cleats on the bottom of the apple box, or a little less to allow for variation. A strip at the lower edge 1x4 inches or 2x4 inches, and another to serve as a rest

for the upper end of the box, constitute all the top that the table needs. To keep the box from sliding off, the cleat on the upper end of the bottom of the box is hooked over the upper strip of the table top. The bench is constructed by first connecting the legs in pairs with a strip near the bottom to serve as a brace and a strip at the top on the same slant as the top of the bench. The ends of the bench-top strips will be nailed to this latter. These sets of legs can be placed from four to six feet apart. They are also braced with three strips running lengthwise of the table—one at the top on either side and one near the bottom at the back.

Some build this table against the wall, under a row of windows, which is well if the windows are at the north. However, in order that the packer may receive his light from the back and sides, and not be interfered with by the attendant in setting on loose boxes and removing packed ones, many turn it so that he can work with his back to the wall. Rollers the width of the apple box are then sometimes arranged at the top edge of the bench to facilitate the attendant's shifting the boxes. Where the packing room is large and the light will permit, the bench-table is conveniently made double, with packers facing each other. To have plenty of room on the packing bench, each packer needs six or seven feet, plus a few extra inches. This allows for one



Fig. 20. Paper "Hod," for Use on Top Edge of Box. *a* Hooks which engage the top edge of the box. *b* Cleat beveled at the same angle as the box so that when it is in place the hod is in a horizontal position.

foot for the paper rack, four or five feet for as many boxes into which apples are being packed, one foot for the box of loose apples, and a few inches for play in sliding the boxes in and out. Where the apple boxes are lined, and the lining paper hangs on the outside of the box during the process of packing, the last item is important, in order to avoid tearing. Where the wrapping paper is kept in front of the packer rather than at the side, the length of the bench can be reduced one foot. The cull box can be kept on the floor under the table, or on a shelf at the front. This shelf is also convenient to hold boxes into which are to be sorted apples of an unusual size or of the grades different from that which the packer is packing—apples that the grader may have overlooked.

Paper Rack

The rack for holding the wrapping paper is sometimes made in the form of a

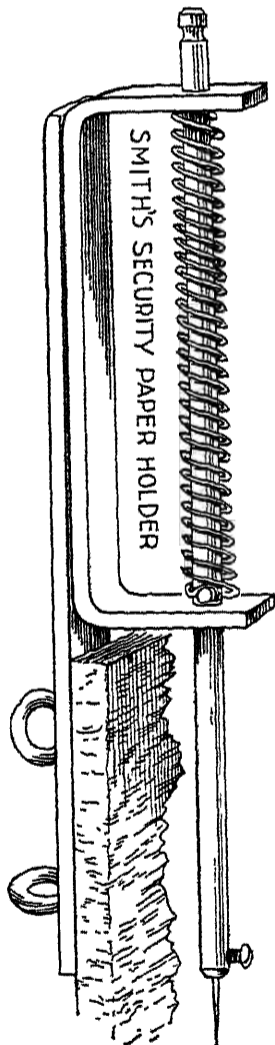

Fig. 21. Paper Holder to Keep Smooth Paper From Picking Up Double. Also for use when packing in the wind. Is attached to the paper rack.

Courtesy A. C. Rulofson Co.

shelf at the rear of the table directly in front of the packer, and high enough above the box to permit grasping the head in removing the box. This rack may be long enough for compartments for two or three sizes of paper and the necessary cardboard. A "hod" for paper is illustrated in Fig. 20. This is made either of wood or of metal, and is constructed with two right angle screw hooks in the edge to engage the edge of the box head and a bracket underneath to support it against the end. If the bracket is cut with a right angle instead of with an acute angle, it can be hooked on the side of the box. Some packers prefer their paper at the side. A side rack on the long packing bench is most convenient when on a level with the top of the box.

Nailing Press

A nailing, or lid, press is a necessity wherever apples are packed in boxes. Its purpose is to press down the ends of the box lid and hold them in place while they are being nailed. Use is made of either bars or clamps. Some believe that bars, such as those on the press shown in Fig. 24, are likely to bruise the apples. If they do not come more than an inch and a half from the edge of the box, however, there is no danger; and this press has the advantage of being suitable for pears. The clamp press holds the cleats in place while being nailed, but if used for pears, which are packed with a higher crown than apples, it may leave most of the bulge on the top of the box. The press supplied with a ratchet or other device to engage the foot lever when it is pushed down, is to be preferred to one without it; else, if the nailer must leave his job for an instant, he must arrange his cleats and cover boards a second time. The press without a protruding foot lever cannot cause bruised shins. Unfortunately no press possesses all the good points. One will have to select according to his own judgment. If the press does not provide it, handy arrangement will have to be made for lid stuff, cleats, nails and rubber stamps. A good nail stripper will pay for itself in saving of time and annoyance to the nailer.

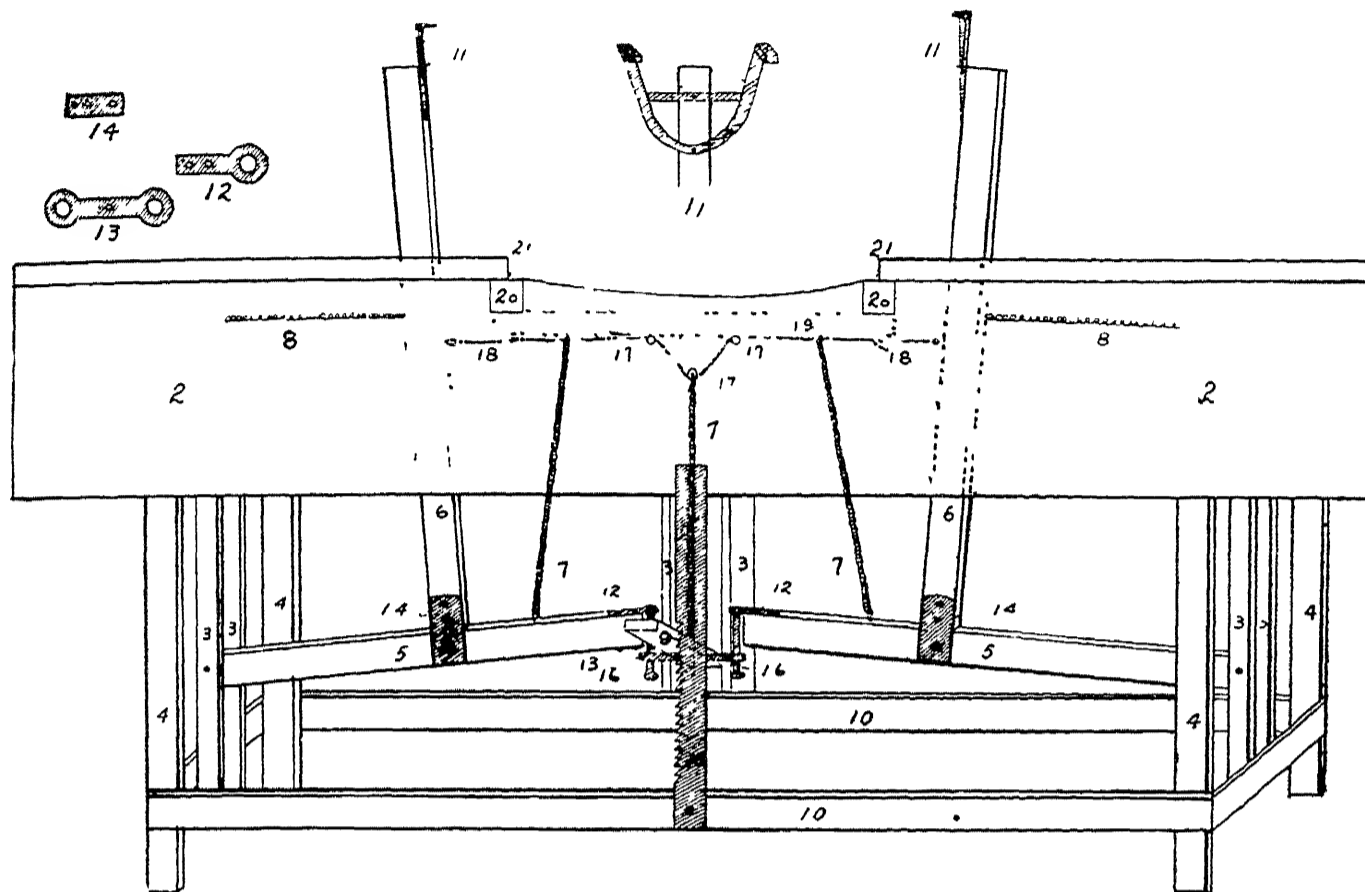

Fig 22. Clamp Nailing Press

- 1 Cover boards to table, extending about half over cross pieces (20) on each side Length of table, 64 inches.
2. Side board to table The part between the cross pieces (20) is cut down to allow a box with bulged bottom to slide off the press.
3. Uprights for attachment of levers (5 and 9).
- 4 Legs of table, 28½ inches long, 1½ inches square. (All the arms, legs and levers of the press may be made of 1½x1½-inch stuff)
5. Levers, 24 inches long.
6. Upright arms, 30 inches long
7. Steel springs, ¾ inch inside diameter The two attached to the levers (5) are fastened at the upper end to spanner (19). The center spring is attached to the foot lever (9) and a pulley (17). All springs are shown relaxed
- 8 Spring attached to upright arm (6) and support (3). These springs should be long and light, such as are often used on screen doors.
9. Foot lever, bolted to uprights (3) at back, and working with catch plate and ratchet in front It is fastened to plate (13).
10. Brace for legs and lower support for uprights. Three inches from ground
11. Horseshoe plate for gripping box cleats and cover It is attached to arm (6) with flat-headed stove bolts, and must be made very true
12. Iron plates bolted to levers (5), with large holes in projecting ends, allowing the bolts (16) to slide freely.
13. Lower plate under lever (9), to which it is bolted loosely, with large holes in each end for free play of bolts (16).
14. Side plate joining lever (5) and arm (6). Two bolts to arm, and one, fitted loosely, to lever
15. Iron ratchet to engage plate on the front lever (9).
16. Half-inch bolts, 2½ inches long, working loosely in the holes in the plates (12 and 13).
17. Three small pulleys for rope attached to arms (6). Center pulley is attached to center spring (7). The other two pulleys are attached to spanner (19).
18. Strong ¼-inch cord that will not stretch. Runs across from arm to arm (6), passing through the three pulleys (17).
19. Spanner running parallel with side, back about 10 inches from front side and directly under center of box.
20. Cross pieces (end view), providing support for box. Attached to it is spanner (19).
21. Grooves for holding box in place. They are a trifle over 19½ inches apart To accommodate the special box, which is 20 inches long, strips may be nailed to the table top one inch back from the opening on either side.

The top of the table must have slots cut in it to allow working of arms. Tables may be of any width desired, but arms should be conveniently near the front.



Fig. 23. Clamp Nailing Press Completed.

PACKING ACCESSORIES

Lining Paper

This is used in all boxes of the better grades of fall and winter apples, and of the poorest grade where the apples are not wrapped. It is used both for the sake of an impression upon the consumer and the effect upon the apples. Its presence indicates care in the preparation of the product. It keeps out dust; also where apples are not wrapped, it prevents their becoming scratched against the rough sides of the box. The quality used is usually that termed "white news." White has become the symbol of sanitation and the American people prefer it. The size of the sheets for the Northwest standard box is $17\frac{1}{2} \times 26$ inches; the size for the special box, $19\frac{1}{2} \times 26$ inches; that for the Colorado box, $18\frac{1}{2} \times 28$ inches. Two sheets are used for each box, the ends of the box to remain bare. This "will allow for a generous overlapping on both top and bottom, and also allow for a pleat to be made on the bottom corners. The pleat is very essential, as it allows for the bulge when the box is nailed. To make this pleat catch the paper on the ends, thus making a fold, draw the paper quickly over the knee, thus creasing it. This crease is generally made about six inches from the end. These pleats will fit in the corners nicely."* Instead of making these pleats many prefer to push the paper a little way through the cracks in the bottom corners of the box to serve the same purpose.

* C. I. Lewis, Horticulturist, Oregon Agricultural Experiment Station; Better Fruit, August, 1911.

Cardboard

This is of light weight, soft, and of an absorbent nature, usually blue or green in color, though the uncolored makes a better looking box. Its size is about one-half inch smaller than the dimensions of the box. It is usually placed only in the bottom and top of the box, and on the inside of the lining paper. It acts as a deterrent against bruises, and as another factor toward a good impression upon the consumer. Some growers, dealers and associations use these sheets upon which to advertise. They also furnish a place to print the season at which the apples in the box are to be eaten. In some districts, notably Hood River, cardboard is also placed between the layers of apples. Mr. C. I. Lewis, Oregon Agricultural Experiment Station, states thus the arguments for the use of cardboards between layers: "They act as pads and tend to lessen the danger from skin slipping; they soak up the extra moisture which may gather from sweating or bruising, and help to confine the decaying fruit so that it will not spread through the entire package, and, moreover, aid to convey to the buyer the thought that he has a superior article."* Consumers are beginning to object, however, that this anxiety of the Northwest fruitgrower to convince as to the quality

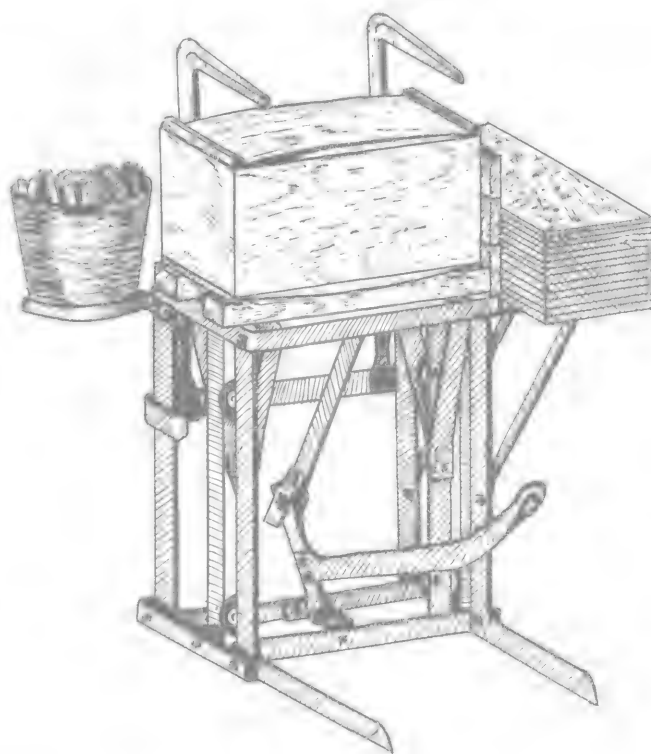

Fig. 24. Bar Nailing Press.

* Better Fruit, September, 1911.

of his product by other means than the apples themselves, can be carried too far; they are balking at the use of cardboard between layers. Under the "square" system of packing no objection but that of expense could be made to its use. Under the present "diagonal" system, however, it does not allow the apples to fit down into the interstices of the layer underneath. Hence smaller and fewer apples must be used, in order that the pack come not too high, and the weight short. The advantages of this use of the cardboard can be cared for sufficiently by the use of wrapping paper.

Wrapping Paper

The advantages of wrapping apples are (1) it checks transpiration and retards the process of ripening; (2) it furnishes a cushion to prevent bruising; (3) it helps to prevent the spread of diseases or decay from one specimen to another; (4) it adds to the appearance of the product, (5) it renders the process of layer packing easier; (6) it enforces layer packing, with a known number of apples of uniform size in every box. The objections to its use are its cost and the opportunity which it affords for a loose pack and short weight. However, if care is taken with the work, the advantages with all but the cheapest apples far outweigh the objections. Manifestly, in the jumble pack the apples cannot be wrapped.

The best paper for wrapping is one that is soft and tough, and that is either rough on one side and calendered on the other—which paper is called "duplex"—or else is rough on both sides. Paper smooth on both sides causes annoyance from picking up double—or worse—air not being able to enter quickly enough when the attempt is made to lift one sheet from the pile. The soft and tough paper does not tear so easily, and makes a neater and quicker wrap. One apple dealer states that the paper should be porous enough to absorb the moisture from the apples as they sweat. White or manila is preferred. Some is of a semi-transparent nature, through which the color of the apples can be seen. The accepted weight is 17 pounds—that is, 17

pounds to a ream of sheets 24x36 inches. To prevent brittleness, with consequent tearing, the paper should be kept in a moist atmosphere, at least for a time before it is used. If no special room is available where humidity can be maintained, moist burlaps can be wrapped about the bundles for a day or so before the paper is to be used. Paper printed with the name and address of the grower or selling agency is sometimes used, especially for the top layer; and for the bottom layer when the latter is "faced." The name of the variety and the brand under which the highest grade is sold, may be included. When the box is put on display the printed wrapper will be seen if the lithograph on the box is not.

Seven and one-half by eight inch paper is large enough for the five-tier sizes of apples. Eight by nine paper can be used where the five and four and one-half tier are packed at the same time. Eight by nine or nine by nine will do for the four and one-half tier alone. Nine by nine or nine by ten can be used where the four and one-half and the four are packed at the same time. Ten by ten can be used for both the four and the three and one-half tier. Ten by twelve is better for sizes seventy-two and sixty-four. Ten by twelve or twelve by twelve are suitable for three tier and two and one-half tier sizes. Care should be taken not to fill the box with paper rather than with apples. At the same time the apples should be entirely wrapped.

Method of Wrapping

Directions for wrapping fruit usually being difficult to understand, the reader may find help in taking an apple and a sheet of paper and performing each motion as it is directed, being sure that he comprehends each step before going on to the next. A rubber finger cot is worn on the thumb or forefinger of the right hand, with which to pick up the paper easily and quickly. Begin by picking up the paper, one corner pointing toward you, the center of the paper in the center of the palm. After some practice you will be able to pick up the paper with-

out looking. At the same time pick up an apple with the left hand. Throw the apple into the paper, and with some force, in order to jerk up the edges of the paper around the apple. Strike the center of the palm with the side of the apple that is to come up in the box. If the apple is to be placed on the cheek, point the blossom end between the thumb and forefinger; which will bring the apple placed in the box on the opposite cheek, with the stem end toward you. Close the fingers as the apple is caught, and the apple is already half wrapped. Now brush the lower edges of the paper closely over the apple with the thumb and forefinger of the left hand, at the same time transferring the grasp from the right hand to these fingers of the left. Now by twisting both wrists toward the left turn the hands completely over, until the back of the right hand is up and the back of the left hand down; at the same time being sure to retain the grasp with the left hand, allowing the apple to turn in the right hand and not with it. During this act, not before, care for the upper edges of the paper with the fingers of the right hand. The apple is now wrapped and ready to be placed into the box with the right hand, the tails of the paper down. One can readily see that if the paper is picked up by the left hand and the apple with the right, these motions would be reversed. However, one is likely to need his stronger hand for placing his apples in the box, in order to make his pack firm; and with most persons this means the right hand. But one method of wrapping is given; packers vary in the details.

The box is usually packed with the folds of the paper turned underneath in all layers. Some growers, however, desire to have the folds turned up in the bottom one or two layers. This is termed "facing" the box, and is meant to make the bottom of the box appear like the top. The practice is to be discouraged, because of the difficulty of making the folds of the apples remain close enough about the apple. Where the two styles of wrap meet in the box, there is danger of bare sides of apples coming into contact if the

packer is at all careless. If the box of apples is likely to be displayed and it is desirable that a certain side should be opened for the purpose, the upper side can be stamped with the word "top." Apple growers of the Hood River district practice this method to some extent. Care should be taken that the labeling on the end of the box is right side up. Where facing is practiced, the apple is thrust into the paper with the side of the apple that is intended to be down in the box turned down in the palm. This is opposite from where facing is not being done. The free hand is then brought over the apple toward the packer, brushing down the upper edges of the paper and turning the apple half way over in the palm. It is in position to be placed in the box, the tails of the paper up.

Stamps and Labels

The grower will need a set of rubber stamps comprising all the numbers corresponding to the sizes that he will be likely to pack, also a stamp for each variety that he grows, and one for each of the two or three grades that he will pack. These should make figures and letters not less than one-half inch in height. He will also need a stamp for his name and address. If he has many boxes to go over, a roller stamp for this purpose will pay, as a time saver. In some states and in Canada the presence of the grower's or the packer's name on the box is obligatory by law. Red ink for stamping, and especially green, should not be used. Letters made with these colors on natural wood are difficult to distinguish in a dim light. Violet or black are to be preferred. About as many orders of arrangement are employed in stamping as there are Western apple growing districts. For the sake of simplicity and neatness, and for the sake of accuracy and convenience in handling at the warehouse, also in the stock room of the dealer, we recommend that all stamping be done on one end of the box, and in the order illustrated in Fig. 25, the other end being occupied by only the lithograph. This, of course, would be pasted on with the top toward the top

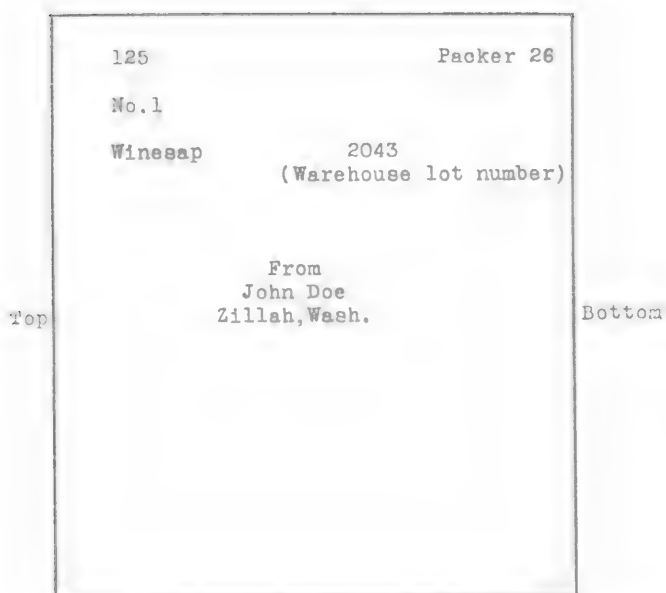

Fig. 25. Suggestion for Stamping an Apple Box. Notice that the box rests on its side, in which position boxes are always piled. The space at the bottom is for an address, in case the box be sent by express. Lithograph to be on the other end, top toward top of box.

of the box, being used to impress the retailer and the "ultimate consumer," who may be expected to open the box from the top.

Lithographs for individuals cannot be recommended. Their use results in too many brands, and confusion in the markets. For the same reason the brand should be made to include as large an output as possible by co-operation. The present tendency is toward the use of brands, rather than of quality designations, for selling the product, a different brand being used for each grade. The brand lends itself easily for advertising purposes. To be of service, it must be somewhat striking. It is more



Fig. 26. Convenient Arrangement for Rubber Stamps and Pad To Be Used in Connection With a Nailing Press.

pleasing if it can be used without the word *brand* accompanying it, the word spoiling the felicity of a name and leaving a shabby taste with the article: e. g., Columbia Apples rather than Columbia Brand of apples. In the Northwest two or three process labels cost from \$3.50 to \$4 a thousand.

GRADES AND TIERS

Some factors governing the price of apples are their size, color and condition (including freedom from blemish or extent of it). In the case of box apples the grade has been determined chiefly by the color and condition, size entering only as a limit, designated by the count in the box, below which apples are to be excluded from a certain grade. But there are certain counts of apples which, almost regardless of grade, vary in desirability, and, to a less extent, in price. In the average market the medium sized apple is more desirable than the large or the small apple. Although on account of the usually limited supply of the large, which does not exceed the limited demand for such large "special purpose" apples, the large apples are not usually sold at a less price, as are the small. In the Northwest, the counts of apples, resulting from the first method by which they were packed, lent themselves readily to a classification into groups, which latter were generalized by a now apparently arbitrary use of the word *tier*, and differentiated by the now equally arbitrary prefixes, 2½, 3, 3½, 4, 4½, and 5.

GRADES

The grades for apples established by the Northwestern Fruit Exchange and the North Pacific Fruit Distributors follow:

Northwestern Fruit Exchange Apple Grading Rules for 1913

Apples will be classed in three grades, known by the packers as No. 1, No. 2 and No. 3.

Specifications of each grade are as follows:

Grade No. 1 [Extra Fancy]

All varieties of apples may be admitted, but they must be clean and of natural

color, shape and condition characteristic of the variety

Physical Requirements

Apples must be sound, smooth and well formed, free from insect pests, disease, blemishes and injuries, worms worm holes, stings, scale, scab, sun scald, dry or bitter rot, decay, fungus, water core, spray burn, limb rub, skin puncture or skin broken at stem

Color Requirements

Solid red varieties, such as Arkansas Black, Winesap, Jonathan and Spitzenburg, must have at least 75 per cent of good natural color

Striped or partially red varieties, such as Delicious, Stayman and Rome Beauty, must have at least 50 per cent of good red color

Red cheeked or blush varieties, such as Winter Banana and Red Cheek Pippin must have a distinctly colored cheek or blush

Size Requirements

Apples in this grade shall not be smaller than 150 except the following varieties, which may be admitted as small as 163

Winesap, Jonathan, King David, Missouri Pippin, Gravenstein, Snow, Yellow Newtown, Grimes Golden, Geniton, Arkansas Black, Jefferis, Spitzenburg and White Pearmain

Grade No. 2 [Fancy]

Physical Requirements

All apples of this grade shall have the same physical condition as Grade No 1 except that slight deviation from proper form may be admitted, but not when clearly misshapen Slight blemishes, such as limb rub, scratches and russetting may be admitted, provided that no apple shall show aggregate blemishes of over one half inch in area

Color Requirements

Solid red varieties must have at least one third of good natural color.

Striped or partially red varieties must have at least one fifth of good red color, except that Rome Beauty may be admitted with 10 per cent color, and if 113 or larger without color requirements

Blushed and yellow varieties no requirements of color

Size Requirements

Apples shall not be smaller than 175 except Jonathans, Spitzenburgs, Newtowns and Winesaps may be accepted as small as 200 if of color requirement of No 1 grade

Grade No. 3 ["C"]

This grade, when used, shall be made up of all merchantable apples not included in the No 1 and No 2 grades Apples must be free from all insect pests disease or serious physical injury including bruises or broken skin Apples shall not be smaller than 150 size No color requirements except that apples must not be immature Apples in this grade should not be wrapped unless specially ordered

The above specifications will govern apple shipments of the Exchange for the 1913 season

The laws of many states as well as trade preferences, require the selling of apples by numerical count hence the system of designating contents of boxes and manifesting by tiers is to be abandoned The only recognized counts for Northwest standard apple packs are as follows 41, 45, 48, 56, 64, 72, 80, 88 96 100, 104, 113, 125, 138, 150 163, 175, 188 200

For convenience in telegraphing etc the above counts are put under Groups Nos 1, 2, 3, 4 and 5, as follows

Group No 1, sizes	45 to 64 inclusive
Group No 2, sizes	72 to 96 inclusive
Group No 3, sizes	100 to 125 inclusive
Group No 4, sizes	138 to 163 inclusive
Group No 5, sizes	175 to 200 inclusive

The standard apple box is 10½x11½x18 inches, inside measurement

Grade Rules North Pacific Fruit

Distributors' 1914 Season

Unanimously adopted after three days discussion by a committee of twenty four, consisting of the trustees and sales managers of the North Pacific Fruit Distributors, the head inspectors and other representatives of all the sub-central districts affiliated with the North Pacific Fruit Distributors

APPLES

The grades to be used will be designated as Extra Fancy Fancy and C Grade and defined as follows

Extra Fancy

This grade shall consist of sound smooth matured clean handpicked well formed apples only free from all insect pests disease blemishes bruises and other physical injuries stings scald scab sun scald dry or bitter rot worms worm holes decay sprays burn limb rub, water core skin puncture or skin broken at stem All apples must be of good matured color shape and condition characteristic of the variety

The following varieties defined as to color shall be admitted to this grade

Solid Red Varieties

Aiken Red	McIntosh Red
Arkansas Black	Mammoth Blk Twig
Baldwin	Missouri Pippin
Black Ben Davis	Spitzenburg (Esopus)
Gano	Vanderpool
Jonathan	Winesap
King David	

Striped or Partial Red Varieties

Ben Davis	Northern Spy
Delicious	Rainier
Gravenstein	Rome Beauty
Jefferis	Hubb rds'n Nonsuch
Jeniton	King of Tompkins Co
Kaighn Spitz	Wagener
Stayman	Wealthy
Snow	York Imperial

Color Requirements

Color requirements for Extra Fancy are as follows

Solid Red varieties to have not less than three fourths good red color and the size of 175 and smaller when admitted to this grade to have at least 90 per cent good red color

Striped or partial red varieties as designated above to have not less than one half good red color and when the size of 175 or smaller is admitted to this grade they must have at least three fourths good red color

Except that Gravensteins, Jefferis and King of Tompkins County in all sizes must be at least one-fourth good red color

Red Cheek or blushed varieties such as Hydes King Red Cheek Pippin Winter Banana Maiden Blush must have a red cheek

Ortleys must be white yellow or waxen

Yellow or green varieties such as Gimes Golden White Winter Pearmain Yellow Newtown and Cox's Orange Pippin must have the characteristic color of the variety

No sizes admitted to this grade smaller than as follows

Aiken Red	200
Arkansas Black	175
Baldwin	200
Ben Davis	163
Black Ben Davis	163
Cox's Orange Pippin	163
Delicious	150
Fall Wine	200
Gano	163
Gimes Golden	200
Gravenstein	200
Hubbardston Nonsuch	163
Hydes King	150
Jeniton	200
Jonathan	200
Jefferis	200
King of Tompkins Co	163
King David	200
Mammoth Black Twig	150
Missouri Pippin	200
McIntosh Red	200
Maiden Blush	163
Northern Spy	150
Oregon Red	175
Ortley	163
Rainier	163
Red Cheek Pippin	163
Rome Beauty	163
Spitzenburg (Esopus)	200
Stayman	163
Snow	225
Vanderpool	163
Winesaps	200
Wagener	200
Winter Banana	150
White W Pearmain	200
Wealthy	200
Yellow Newton	200
York Imperial	163

All boxes to be lined and cardboard to be used top and bottom

No apples accepted in boxes showing worms or cocoons

All apples to be wrapped

Fancy Grade

In this grade all apples must be matured, handpicked, clean and sound, free

from insect pests, water core, sun damage, skin puncture, or skin broken at stem, scald, dry or bitter rot, worms, worm stings, scale, infectious diseases and all other defects equally detrimental, excepting that slight limb or leaf rub, scratches or russeting will be permitted, provided that no apple shall show total blemishes aggregating more than one inch square, in sizes 125 and larger. Fruit clearly misshapen, bruised or bearing evidence of rough handling shall not be permitted in this grade.

The varieties admitted to this grade are the same as in the Extra Fancy.

Color requirements are as follows:

The solid red varieties must have fully 40 per cent of good solid red color.

Striped or partial red varieties must have at least one-fourth of good red color.

Red cheeked or blushed varieties must have correct physical qualities with tinge of color.

All apples of a green or yellow variety shall be of characteristic color.

No sizes shall be admitted to this grade smaller than as follows:

Aiken Red	200
Arkansas Black	163
Baldwin	163
Ben Davis	163
Black Ben Davis	163
Cox's Orange Pippin	150
Delicious	150
Fall Wine	175
Gano	163
Grimes Golden	200
Gravenstein	200
Hubbardston Nonsuch	150
Hydes King	150
Jeniton	200
Jonathan	200
Jefferis	200
Kaighn Spitz	200
King of Tompkins Co.	163
King David	200
Mammoth Black Twig	150
Missouri Pippin	200
McIntosh Red	200
Maiden Blush	163
Northern Spy	163
Oregon Red	163
Ortley	163
Rainier	163
Rome Beauty	163
Red Cheek Pippin	163
Spitzenburg (Esopus)	200
Steele Red	150
Stayman	150

Snow	200
Vanderpool	150
Winesaps	200
Wagener	200
Winter Banana ..	150
White W. Pearmain ..	200
Wealthy	200
Yellow Newton	200
York Imperial ..	163

All boxes to be lined and cardboard to be used top and bottom.

No apples accepted in boxes showing worms or cocoons.

All apples to be wrapped.

Single Grade

The following apples to be packed in one grade combining the Extra Fancy and Fancy grades as provided by these grading rules, size not smaller than 163 count, windfalls absolutely excluded. This pack to be marked or labeled as Fancy.

Apple of Commerce	Palouse
Baldwin	Pewaukee
Ben Hur	Pryor Red
Bismarck	Rambo
Canada Red	Rhode Isl. Greening
Chicago	Roxbury Russet
Champion	Russian Red
Delaware Red	Salome
Golden Russet	Shakelford
Hoover	Senator
Ingram	Stark
Kaighn Spitzenburg	Steele Red
Kentish	Swaar
Kinnard	Wallbridge
Mann	Westfield
Mother	Willow Twig
McMahon	Yellow Bellflower
N. West'n Greening	

All boxes to be lined and cardboard to be used top and bottom.

All apples to be wrapped.

Exceptions

Summer varieties, such as Astrachan, Bailey's Sweet, Bietigheimer, Duchess, Early Harvest, Red June, Strawberry, Twenty Ounce Pippin, Yellow Transparent and kindred varieties not otherwise specified in these grading rules, together with Early Fall varieties, such as Alexander, Blue Pearmain, Wolf River, Spokane Beauty, Fall Pippin, Waxen, Tolman Sweet, Sweet Bough and other varieties not provided for in these grading rules as grown in sections of early maturity, shall be packed in accordance

with the grading rules covering Fancy Grade as to defects but regardless of color rules; size not smaller than 163 count for the larger growing varieties, and 200 count for the smaller growing varieties; wind falls to be absolutely excluded. All boxes to be lined and cardboard used top and bottom.

“C” Grade

This grade is provided to be used when market requirements justify and shall consist of apples not smaller than 163 count. This grade shall be made up of all merchantable apples not included in the Extra Fancy or Fancy grades. Apples must be free from all insect pests, worms, worm holes, and infectious diseases. Serious physical injuries, skin puncture, bruised or broken skin will not be permitted and not exceeding two stings thoroughly healed. There are no requirements as to color except that the fruit must be matured. This grade to be packed in accordance with trade requirements.

No apples accepted in boxes showing infection of worms or cocoons.

Recommendation

The executive board advises the use of the regular Northwestern standard apple box, inside measurements, 10½x11½x18, with solid ends. Inasmuch as the laws, as well as the trade requirements, will force us to sell our apples by numerical count, we abolish the system of designating or manifesting fruit by tiers and will employ the numerical system exclusively hereafter.

The recognized and endorsed counts for the Northwestern standard apple pack are as follows:

36	80	125	200
45	88	138	213
48	96	150	225
56	104	163	
64	112	175	
72	113	188	

Crab Apples

These should be carefully assorted as to varieties, making one grade only, keeping out all insect pests, worm holes, sting, scale, misshapen and blemished

fruit. Put up in apple boxes; line the box; fill in gently so as to prevent bruising.

Lady Apples

. These should be packed in half boxes; boxes lined, remembering that the more attractive the better the sale. Make only one grade, keeping out all insect pests, worm holes, sting, scale, misshapen and blemished fruit.

PEARS

Bartlett, Buerre Clargo, Buerre d’Easter, Clapps Favorite, Flemish Beauty, Duchess, Howells and other varieties not otherwise specified in these rules shall be packed in two grades, being the Fancy and the “C” grade.

Standard boxes, 8½x10½x18, only to be used and the following weights to be observed: Bartletts, Buerre Clargo, Buerre d’Easter, Flemish Beauty, to weigh from 50 to 52 pounds gross.

Clapps Favorite and Howells to weigh from 48 to 52 pounds gross.

Winter Nelis to weigh at least 46 pounds gross.

Grades defined as follows:

“C” Grade

This grade to consist of all merchantable pears not included in other grade, but must be free from worms, scale, stings, or other insect pests. Slightly misshapen pears or pears having limb rub or other defects not spoiling the merchantable quality of the fruit shall be accepted. Punctures or skin broken at stem must be kept out.

Size of fruit to be not less than 2¼ inches in diameter, except Winter Nelis, which shall be not less than 1¾ inches.

Buerre d’Anjou, Comice, Buerre Bosc: These three varieties shall be packed in three grades, being Extra Fancy, Fancy and “C” grade. When packed should not weigh less than 48 to 50 pounds gross.

Grades defined as follows:

Extra Fancy

This grade shall consist of pears not less than two inches in diameter; must be hand picked, clean and sound, free from insect pests, sun damage, broken skin, scale, scald, worms, worm stings,

infectious diseases, limb or leaf rub, misshapen fruit and all other defects equally detrimental. Fruit bruised or punctured or showing other evidences of rough handling shall not be permitted in this grade. Pears must have stem or part of same intact.

Fancy

This grade shall be but slightly below the Extra Fancy pack; and shall consist of pears not less than two inches in diameter (except Winter Nelis, which shall not be less than $1\frac{3}{4}$ inches); must be hand picked, clean and sound, free from insect pests, sun damage, broken skin, scald, scale, worms, worm stings, infectious diseases and all other defects equally detrimental, excepting that slight limb or leaf rub, scratches or russeting will be permitted provided no pear shall show total blemishes aggregating more than one-half inch in diameter. Pears must have stem or part of same intact. Fruit clearly misshapen, bruised, or bearing evidence of rough handling shall not be permitted in this grade.

"C" Grade

This grade should be the same as the "C" grade provided for the other varieties of pears.

Seckel Pears

These should be packed in half boxes, the top faced, and then filled gently so as to prevent bruising. Boxes to be lined. Make one grade only, keeping out all insect pests, worm holes, stings, scale, misshapen and blemished fruit.

PEACHES

Peaches should be picked for packing only when fully developed, but firm or hard ripe. Yellow meated varieties should show some yellow color. The fruit should be picked and laid in the baskets or pails, not dropped, and should be taken from the vessel only at packing table. All possible care should be used to avoid bruises.

Use standard peach boxes; cleats on top only; use 4d special orange box cement nails for bottoms and sides. Drive nails one inch from corner. Four nails to each piece. Use three 4d cement box

nails to each cleat—one in the center, and one driven two inches from the end of the cleat. The cover should hold the fruit firmly in the box but should not bulge more than $\frac{3}{8}$ inch. Use $4\frac{1}{2}$ -inch boxes only for Elberta peaches, running 50 to 84, both inclusive, avoiding the use of extra cleats except in extreme cases. Peaches that are too large to be laid in the box five wide should be packed two and three in $4\frac{1}{2}$ -inch boxes. If the peaches are roundish, as in the case of Crawford's, it will be necessary to use some four-inch boxes with this pack.

Peaches that will go five across the box or smaller should be packed three and three in four-inch boxes. The excellence of the pack depends upon uniform grading. The peaches in a box should not vary more than $\frac{1}{8}$ inch in diameter. All grades must be carefully wrapped in suitable paper.

Peaches that run less than 96 to the box should not be packed for shipment. Eighty-four count should be the minimum for Elbertas. In packing the box should sit on an incline with the lower end of the box to the packer. Both tiers should be carried forward together. The peaches should be placed in the box stem end down, those in the top tier resting in the spaces between those in the lower tier so that no peach will rest squarely on top of another. Pack all peaches with the loose end of the wrapper down. No over-ripe, undersized, immature, bruised, misshapen, diseased, wormy, or otherwise defective fruit should be packed. Over-ripes may be packed for special purposes with the letter "R" marked on the end of the box.

All marks should be placed on one end of the box only. The variety shall be placed in the upper right hand corner; the number of peaches in the upper left hand corner and the grower's name at the top in the middle, and name of local district in the lower right hand corner. Use rubber stamps.

Each local district shall employ an inspector qualified to give instructions in picking and packing, and whose duty it will be to see that each packing house is

superintended by persons competent to enforce these rules

CANTELOUPES

With a view of promoting this important industry more care must be used in grading and packing. It is absolutely necessary that a standard grade be adopted, as well as a standard of pack.

The commercial counts as recognized for canteloupes are the 36 count or Jumbos; the 45 count or Standards; the 54 count or Pony.

There must be a straight pack, uniform size canteloupes in each grade, clean and at a stage of uniform ripeness that will permit long distance shipment.

These rules were in use in the several districts for the season of 1913-14. The rules governing the grades for box apples in Canada, as established by the Canadian "Fruit Marks Act," appear in this work under Laws

MEANING OF TIER

Nothing is more puzzling to the novice at apple packing than the modern use of the word *tier*. This present use can be explained best by a statement of a few of the facts connected with the transition that has taken place in the use of the word. Originally apples were packed according to the layer method only in the square style. Apples were mixed as to size in any manner that would admit of their being packed "square," or straight across the box, in either three, four or five layers. Tradition says that the first grower who brought his apples into North Yakima, Wash., packed diagonally was unable to find a buyer that would accept them, and was compelled to take them home and repack them "square." Apples were spoken of as being either three, four or five-tier, according to the number of rows running crosswise of the box and the number of layers in depth, the two being the same. However, when a need was felt for a more exact grading as to size, a limited use of the two-two* and three-two° packs was begun. Any apple

* See Styles of Pack, Two-Two Pack, this article.

° See Styles of Pack, Three-Two Pack, this article.

that was placed into the two-two pack was called a three and one-half tier apple, and the pack a three and one-half tier pack, the literal meaning of this being that it would require approximately three and one-half of the apples to fit in a row crosswise of the box, or from top to bottom. Likewise, any apple that was placed in the three-two pack was called a four and one-half tier apple and the pack a four and one-half tier pack, meaning that it would take approximately four and one-half of the apples of that size to fit in a row in like directions as above. The trade paid for apples according to the size as well as the quality, designating the size by the tier pack into which they were placed

In very recent years "square" packing has been abandoned, due to the recognition of the fact that apples packed according to this method receive the more and greater bruises in nailing up and handling, when compared to apples packed diagonally; and the use of the diagonal packs has been extended to accommodate these apples formerly packed "square." The terms *three tier*, *four tier*, *five tier*, have been retained to designate the sizes of apples which were formerly given the three, four or five tier pack, although they are now packed two and one-half, three and one-half, or four and one-half tier. We have four tier apples, but no four tier pack.

Counts 36, 41, and 45, are called two and one-half tier, or sometimes three tier. Counts 48, 54, 56, are called three tier. Counts 64, 72, 80, 88, are called three and one-half tier. Ninety-six is sometimes placed into this group, but is usually included in the next. Counts 96, 100, 104, 112, 113, 120, 125, 128, are called four tier. Counts 138, 150, 163, are four and one-half tier. One hundred and seventy-five is designated either four and one-half or five tier, the latter custom predominating. Sizes 188 to 225 are called five tier. Sizes smaller than 225 are either called five tier, or given no tier designation at all.

Formerly the tier was stamped on the box, frequently without the number. Now

the number is used, the tier rarely appearing. An increasing number of persons believe that the confusion frequently arising from the use of the term *tier* warrants its complete abandonment. Certainly *small*, *medium*, *large*, would express as much. Apple dealers are beginning to identify by the actual counts rather than by any name classifying them.

STYLES OF PACK

Jumble Method

Apples are packed in boxes according to the jumble and the layer methods. The jumble method is only a modification of the barrel pack. It has been used chiefly in Colorado, and is sometimes called the "Colorado" pack. In this pack, two layers are first placed into the box stem end down, in what is called the three-two order. (See three-two pack.) The box is then poured full, and the top arranged as regularly as possible, stem end up. When nailed, the box is reversed, the side which was packed first being considered as the top. Apples packed thus are never wrapped, although the boxes are usually lined. The apples are rarely graded so closely for size as where the layer pack is used. The advantages of this method are: (1) its cheapness and (2) the rapidity with which the packing is accomplished. The objections are: (1) it requires a larger box for the same weight of apples than the layer method; (2) the apples cannot be given the advantages of wrapping; (3) there is less incentive toward securing uniformity of size; (4) the interior of the package does not present so pleasing and finished an appearance, from which it might be inferred that the value of the apples does not warrant care in packing them.

Layer Method

The two types of the layer pack are the square and the diagonal, or "diamond." The advantages and disadvantages of the layer pack are inversely those of the jumble pack. In the square pack the rows of apples run parallel to the edges of the box in all directions. In the diagonal pack the rows run diagonal-

ly from one side of the box toward the opposite side in all directions. The objection to the square pack is that in it one apple bears directly against another, both crosswise and from top to bottom through the box; so that when pressure is brought against the top, bottom or side of the box, it causes a direct pressure throughout the rows, with bruises as the result. The advantage of the diagonal pack is that in it each apple fits into the interstice between other apples, and when pressure is brought to bear upon it, instead of forcing itself directly against another apple, it tends to shove the other apples aside and make its way between them, these other apples tending to shove their way between still others, and so on; so that no direct pressure results, but a modified one. This explains why the diagonal pack has superseded the square

Diagonal Pack

There are six possible forms of the diagonal pack: Two-one, two-two, three-two, three-three, four-three, four-four. The three-three and four-four packs are called "offset" packs. In these are also distinct rows running crosswise of the box. These rows begin alternately at either side of the box, ending with a space at the opposite side, hence the term "offset." The objections to the offset pack are that it leaves large holes at the side of the box, from which point the box is opened by the buyer for inspection; also that its use tends toward confusion in packing, by multiplicity of styles. The same apples pack well in the three-two and two-two packs; except in the case of some small apples, when the three-three pack is needed. The only layer packs now sanctioned by the best usage in the Northwest, are the two-one, the two-two, the three-two, and a few small sizes of the three-three pack.

Two-One Pack

To begin the two-one pack, place an apple in the lower left hand corner of the box, then one in the lower right hand corner, then a third between the two. They will be of such a size that the third will not slip toward the lower head of

the box over half way between the first and second. Repeat, placing the apples in the same relative position as the first three, until the upper head of the box is reached. This first layer may end with two apples and one space, or with one apple and two spaces. Begin the second layer by placing an apple above the space left between the first two apples in the bottom layer. The apple will fall down into the space a trifle. Place the next two apples on either side of the first. The three will be of such a size that the outer two will not slip toward the lower head over half way on either side of the middle one. The apples in the second and third layers fit directly over the interstices between two apples in the layer underneath, except the end apples,

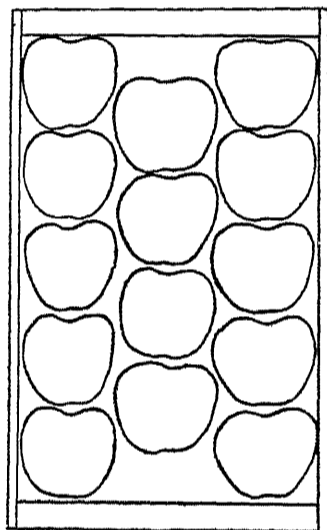

Fig 27 Two one Pack, 41 Apples

which fit over a space between an apple and the head of the box. Three layers of the two-one pack fill the box.

(1) When the outer rows of a layer touch one head of the box, with spaces at the other end, the middle row touches the other head with a space at the opposite end; and all the rows contain the same number of apples. In the box with all layers constructed thus, every layer contains the same number of apples. The number of apples in the box is determined by counting the number in the top layer and multiplying by three, the number of layers. (2) When the outer rows of a layer reach from head to head of the box, the middle row has a space at both ends, and contains one apple less. On the other hand, when the

middle row touches both heads of the box and the outer rows each has a space at both ends, each contains one apple less. The layer constructed after the latter contains one apple less than the layer constructed after the former manner. Now the first and third layers of the box each contains the same number of apples; but they are constructed after the former manner and the second layer after the latter. Therefore the second layer contains one apple less than the first and the third. To determine the number of apples in this box, count the apples in the top layer, multiply by three, and subtract one.

Where the outer rows of the first layer each contains four apples and the middle row also four, the pack is described as being three deep, two-one wide, and four-four long, with 36 apples to the box. When the outer rows of the first layer each contains five apples and the middle row four, the pack is described as being three deep, two-one wide, and five-four long, with 41 apples to the box. When the outer rows of the first layer each contains five apples and the middle row also five, the pack is described as being three deep, two-one wide, and five-five long, with 45 apples to the box.

The two-one pack, though correct, is rarely used. Few apples grow large enough to pack into it, and these are usually of too poor quality for commercial purposes. It is sometimes put up as an exhibition pack with which to stun the land looker. To decide whether a certain size of apple should be packed in the two-one or in the two-two pack, try to place three of the apples cheek to cheek in a row crosswise of the box. If the apples are so large transversely that there is not room for three of them in the row, they are to be packed two-one. If three of them fit across snugly, or if they are so small that three do not reach across, they are to be packed two-two.

Two-Two Pack

To begin the two-two pack, place an apple in the lower left hand corner of the box, then one in the middle of the space between the first apple and the right hand

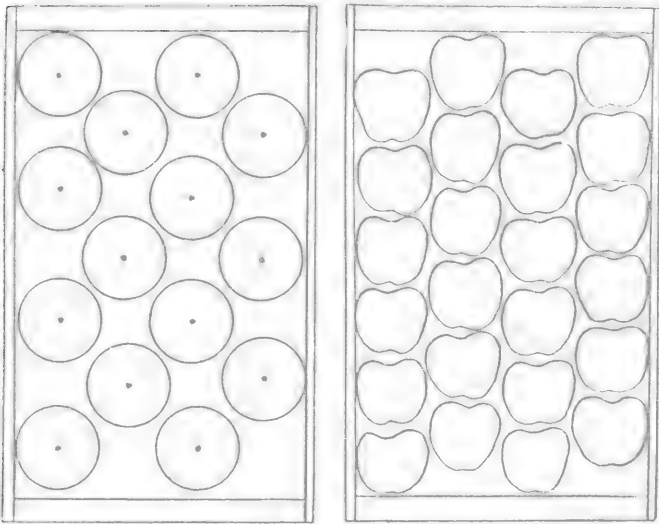

Fig. 28. Two-two Pack, 56 at Left, 96 at Right.

side of the box, then a third and a fourth in the two remaining spaces. The apples will be of such a size that the third and fourth will not slip over halfway into these spaces. Repeat placing the apples in the same relative position as the first four until the upper head of the box is reached. The first and third rows, counting from either side, may end with an apple touching the upper head of the box, and the second and the fourth with a space. Begin the second layer by placing an apple over each of the spaces against the lower end of the box in the first layer. Place the next two apples in the spaces made by these. The four will be of such a size that the second two will not slip into these spaces over half their length. The apples in the second layer and in each



Fig. 29. Method of Starting the Two-two Pack (at right) and Three-two Pack (at left).

succeeding layer, fit directly over the interstice between two apples underneath; except the end apples, which fit over the space between an apple and the head of the box. Four layers of the two-two pack fill the box. Each contains the same number of apples. The number of apples in the box is determined by counting the number in the top layer and multiplying by four, the number of layers.

The following are the counts of the two-two pack, with the length of rows in each: 48, 3-3; 56, 4-3; 64, 4-4; 72, 5-4; 80, 5-5; 88, 6-5; 96, 6-6; 104, 7-6; 112, 7-7; 120, 8-7. Extremely flat apples are required for counts 112 and 120. To decide whether a certain size of apple should be packed into the two-two or into the three-two pack, try to place four of the apples cheek to cheek crosswise of the box. If the apples are so large that there is not room for four of them in the row, the apples are to be packed two-two. If four of them fit across snugly, or if they are so small that four of them do not reach across, they are to be packed three-two.

Three-Two Pack

To begin the three-two pack, place an apple in the lower left hand corner of the box, then one in the lower right hand corner, then a third equidistant between the two. Then place an apple in each of the two remaining spaces. All five will be of such a size that the last two will not slip over half way into the spaces. Repeat, placing the apples in the same relative position as the first five until the upper head of the box is reached. Begin the second layer by placing an apple over each of the two spaces left in the bottom layer against the lower head of the box. Place the next three in the space between these two and the two spaces on either side of them between them and the sides of the box. The five will be of such a size that the last three will not slip over half way into the space. The apples in the second layer and in each succeeding layer fit directly over interstices in the layer underneath. Five layers of the three-two pack fill the box.

1. When the outer rows and the middle row of a layer touch one head of the

box, with spaces at the other end, the second and fourth rows touch only the opposite head of the box. All the rows in each layer contain the same number of apples, and each layer contains the same

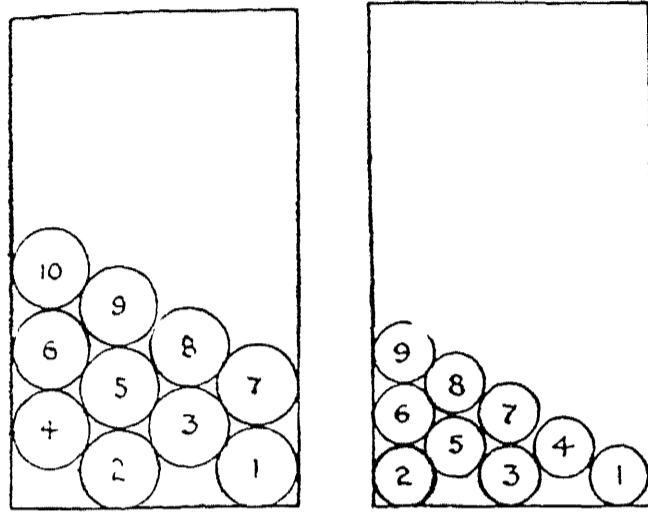

Fig 30 Three-two Pack 113 at the left, 175 at the right

number. The number of apples in the box is determined by counting the apples in the top layer and multiplying by five, the number of layers.

2 When the outer rows and the middle row of a layer reach from head to head of the box, the second and fourth rows each has a space at both ends and each contains one apple less. On the other hand, when the second and fourth rows reach from head to head, the first, third and fifth each has a space at both ends and each contains one apple less. Then the layer constructed after the latter, contains one apple less than the layer constructed after the former manner. Now the first, third and fifth layers of the box each contains the same number of apples, and the second and fourth the same. But the first, third and fifth layers are constructed after the former manner, and the second and fourth after the latter. Hence the box contains two layers each containing one apple less than the other three; and to determine the number of apples, count those in the top layer, multiply by five, the number of layers and subtract two.

The counts of the three-two packs, with the length of rows in each are: 100, 4-4; 113, 5-4; 125, 5-5; 138, 6-5; 150, 6-6; 163, 7-6; 175, 7-7; 188, 8-7; 200, 8-8; 213, 9-8;

225, 9-9. The count 100 is sanctioned only for the use of very long apples, such as some Spitzenburgs and Ortleys, which would pack slack crosswise of the box and not allow of a proper height if put into the 96 two-two pack. Sizes 200, 213, and 225 can be used successfully only for apples somewhat flat. Long apples for these sizes will likewise be slack crosswise and come too low. They can be packed three-three. To decide whether a certain size of apple should be packed into the three-two or the three-three pack, try to place five of them cheek to cheek crosswise of the box. If the apples are so large that there is not room for five of them in the row, the apples are to be packed three-two. If the five of them fit across snugly, or if they are so small that five of them do not reach across, they are to be packed three-three.

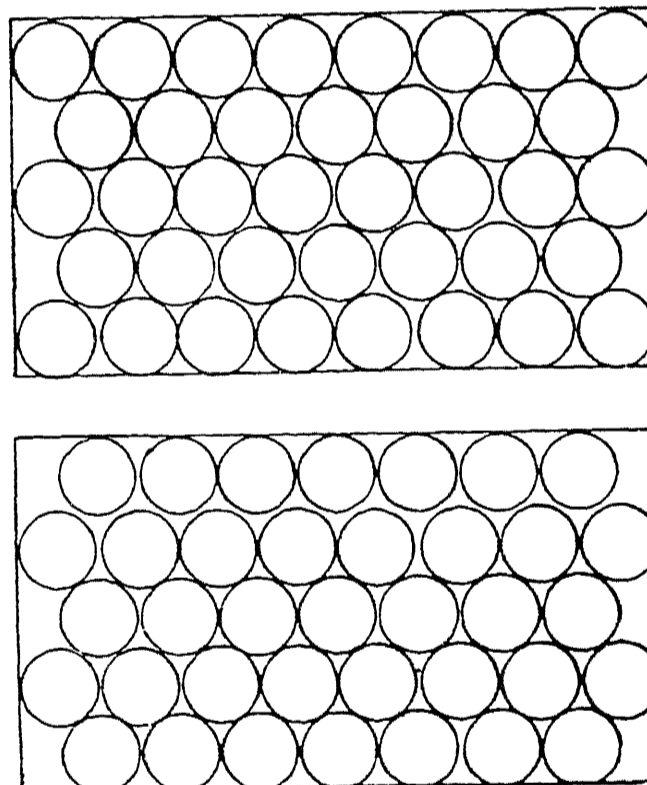

Fig 31 The Five Layers of a Three-two Pack where the rows are of unequal length. One hundred eighty-eight apples. If the top layer of the box were counted and this number multiplied by five, the result would be 190. If the layers are reversed there will be 187 apples.

Three-Three Pack

To begin the three-three pack, place three apples against the lower head of the box, beginning at the left hand side, leaving three spaces of equal size, one at the right of each apple, the last being between the third apple and the right

hand side of the box * Next place three apples in the three spaces. The six apples will be of such a size that the latter three will not slip over half way into the spaces Repeat, placing the apples in the same relative position as the first six until the upper head of the box is reached. The first, third and fifth rows, counting from either side, may end with an apple touching the upper head of the box, in which case the second, fourth and sixth each ends with a space. Begin the second layer by placing an apple over each of the spaces left in the first layer against the lower head of the box. Continue as in the first layer. Each apple fits directly above a space or interstice below. Six layers of the three-three pack fill the box. The number of apples in the box is determined by counting the apples in the top layer and multiplying the number by six, the number of layers. The only counts of the three-three pack now used, with the length of rows in each are: 198, 6-5; 216, 6-6; 234, 7-6; 252, 7-7. The value of the three-three pack for apples which are long in shape and which will come both loose crosswise and low when packed three-two, 200, 213, 225, is not sufficiently appreciated by some districts of the Northwest It is only occasionally found profitable to pack apples smaller than 198 or 200.

Offset and Square Packs

These are now chiefly of historical interest, having been discarded because both objectionable and unnecessary, as previously stated. Sizes of the three-three off-

* The three three pack is begun in the same way as the offset, except that the apples are much smaller and that the stems are all pointed one way See Fig 32

set pack, containing four layers were 72, 84, 96 A three-three offset pack is illustrated in Fig 32. Sizes of the four offset pack, containing five layers were 160 and 180. Sizes of the square pack, with the length of row and the depth, are as follows: Three layers 45, five in rows; 56, six in rows Four layers: 96, six in rows, 112 seven in rows, 128, eight in rows Five layers 200, eight in rows; 225, nine in rows In the special box 63 apples, seven apples to

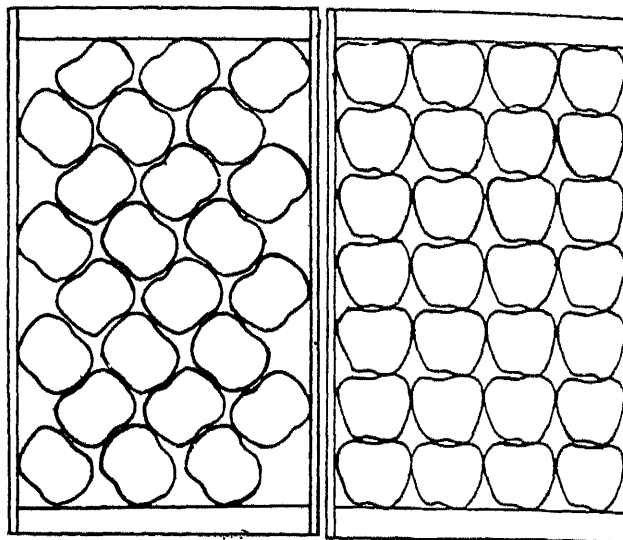

Fig 32. Offset Pack, 96 Apples, Obsolete
Fig 33. Square Pack, Obsolete

the row, three layers; also 144 apples, nine to the row, four layers, can be packed.

Packs for the "Colorado" Box

The "Colorado" box, being of a different shape and size from the Northwest standard, accommodates a different list of counts, modified by the Colorado custom of packing the apples always flat The following tables are taken from the grading and packing rules and instructions of the Grand Junction Fruit Growers' Association for the season of 1912:

Long Apples

All apples of the varieties following may be termed "long apples," and should be packed as per following formulas: Gano, Ben Davis, White Winter Pearmain, Bellflower, etc.

Size	Pack	Layer Contains	No. Layers in Box	Box Contains
$2\frac{1}{4}$ — $2\frac{1}{2}$ inch	3—3x6—6	36	7	252
$2\frac{1}{2}$ — $2\frac{3}{4}$ inch	3—3x5—5	30	6	180
$2\frac{3}{4}$ —3 inch	3—2x5—5	25	6	150
3 — $3\frac{1}{4}$ inch	3—2x5—4	2—22 3—23	5	113

Flat Apples

All apples in the following list may be termed 'flat apples' and should be packed as per formulas for flat apples Jonathan Winesap Missouri Pippin, Minkler, Rome Beauty, Arkansas Black, etc

Size	Pack	Layer Contains	No Layers in Box	Box Contains
2 $\frac{1}{4}$ —2 $\frac{1}{2}$ inch	3—3x6—6	36	8	288
2 $\frac{1}{2}$ —2 $\frac{3}{4}$ inch	3—3x5—5	30	7	210
2 $\frac{3}{4}$ —3 inch	3—2x5—6	3—28 3—27	6	165
3—3 $\frac{1}{4}$ inch	3—2x4—4	20	6	120
3 $\frac{1}{4}$ —3 $\frac{1}{2}$ inch	2—2x5—5	20	5	100
3 $\frac{1}{2}$ —3 $\frac{3}{4}$ inch	2—2x5—4	18	5	90

There are many other varieties that might have been classed under these two heads, but these must be compared and packed as the variety they most resemble in shape

* See definition of flat pack under next caption

Schedule of Diagonal Packs for Standard Apple Box

Style of Pack	Count	No in Rows	No of Layers	Tier Designation
2-1	36	4-4	3	3 (2 $\frac{1}{2}$)
2-1	41	5-4	3	3 (2 $\frac{1}{2}$)
2-1	45	5-5	3	3 (2 $\frac{1}{2}$)
2-2	48	3-3	4	3
2-2	56	4-3	4	3
2-2	64	4-4	4	3 $\frac{1}{2}$
2-2	72	5-4	4	3 $\frac{1}{2}$
2-2	80	5-5	4	3 $\frac{1}{2}$
2-2	88	6-5	4	3 $\frac{1}{2}$
2-2	96	6-6	4	4
2-2	104	7-6	4	4
2-2	112 (flat apples)	7-7	4	4
2-2	120 (flat apples, rare)	8-7	4	4
3-2	100 (long apples)	4-4	5	4
3-2	113	5-4	5	4
3-2	125	5-5	5	4
3-2	138	6-5	5	4 $\frac{1}{2}$
3-2	150	6-6	5	4 $\frac{1}{2}$
3-2	163	7-6	5	4 $\frac{1}{2}$
3-2	175	7-7	5	5 (4 $\frac{1}{2}$)
3-2	188	8-7	5	5
3-2	200 (flat apples)	8-8	5	5
3-2	213 (flat apples)	9-8	5	5
3-2	225 (flat apples)	9-9	5	5
3-3	198 (long apples)	6-5	6	5
3-3	216 (long apples)	6-6	6	5
3-3	234	7-6	6	5 or 6

Additional Diagonal Packs for Canadian Apple Box

Style of Pack	Count	No. of Rows	No. of Layers	Tier Designation
2-1	50	6-5	3	3
2-1	54	6-6	3	3
2-1	59	7-6	3	3
2-1	63	7-7	3	3
2-2	120	8-7	4	4
2-2	128	8-8	4	4
2-2	136	9-8	4	4
2-2	144	9-9	4	"Special"

Peach Packs

Style of Pack	Count	Long	Tier Deep
3-3	96	8-7	2
3-3	84	7-7	2
3-3	78	7-6	2
3-3	72	6-6	2
3-2	65	7-6	2
3-2	60	6-6	2
3-2	55	6-5	2
3-2	50	5-5	2
3-2	45	5-4	2
3-2	40	4-4	2
2-2	36	5-4	2

Pear Packs

Style of Pack	Count	Long	Tier Deep
4-3	245	7-7	5
4-3	228	7-6	5
4-3	210	6-6	5
4-3	193	6-5	5
3-3	180	6-6	5
3-3	165	6-5	5
3-3	150	5-5	5
3-3	135	5-4	5
3-3	120	4-4	5
3-2	110	6-5	4
3-2	100	5-5	4
3-3	90	5-4	4
3-2	80	4-4	4
3-2	70	4-3	4
3-2	60	3-3	4

Where Dispose of the Stem

According to the best practice of the apple packers of the Northwest a uniformity with regard to the direction in which the stem is to point, is observed in placing the apples in the box. The picking up and wrapping of the apple in such a way that it becomes handy to place it in the box in the proper position becomes automatic. There has been much discussion as to whether the apple should be placed stem downward, stem upward, or stem pointing toward the end of the box. In the latter case the pack is called a "cheek" pack, because the cheek of the apple is presented to view on the top layer, or because the apple is placed in the box on its cheek. A "stem" pack is one where the stem points upward on the top layer. An "end" pack is usually one that exposes the calyx end on the top layer; though it may mean the same as a "flat" pack, which term is applied to a pack where the apple is placed with either the stem or the calyx end up. In any flat pack all layers but the top are usually placed with the stem end down, and the corners of the wrapping paper folded over the stem to prevent its puncturing any apple below it. An "oblique," "tilting," or "disked" pack is one where the apples are placed in the box in an oblique, or tilting, position. The apples may all be leaned from the ends of the box toward the center—especially in apples of a two-two size; all layers may be leaned toward one end of the box, those in the middle at a slightly less angle to form the crown of the pack; or the layers may alternate as to the end of the box toward which they are inclined. For the three-two size of apples the second method is the most satisfactory. In this it is well to lay flat the first three apples in the bottom layer, in order to help in keeping that end of the pack low and to render more easy the start at placing the apples in on a slant.

The manner in which the apple is to rest in the box is usually determined by its size and shape. The sizes of the two-two pack smaller than 80 and of the three-two pack smaller than 150 pack best

on the cheek. Apples of the larger sizes of these two packs, if somewhat spherical, are packed on end, and if quite flat are packed obliquely. Expressed differently, the cheek pack can be used to make a higher crown to the pack, the flat pack to make a lower crown, and the oblique pack to make one of medium height. There is some difference of opinion as to whether the cheek or the flat pack is to be preferred in itself, or where a choice is to be made. In Colorado, with the use of the "Colorado" box, all apples are packed flat. Where wrapping is not practiced, the apples stay in place better thus. On the other hand, an increasing number of persons in the Northwest are packing all apples on the cheek. This, in the case of apples which are indicated above to be packed on end, they do at the expense of firmness of pack, looseness being necessary to allow of a sufficiently low crown. The chief advantage of the cheek pack is that it presents a more pleasing (because less confused) appearance when on display, with an opportunity to expose the more highly colored sides of the apples. Also fewer stem punctures result from its use if the apples are of a long stemmed variety. In this connection it should be stated that when the cheek pack is employed for the larger sizes of both the three-two and the three-three packs, care must be exercised not to allow the apples to twist sidewise while building the pack, but to keep the stem and calyx ends of the apples pointing straight toward the ends of the box; else the pack will come too high by the reduction of the size of the pockets into which the apples of the layer above are to fit. When the apples thus show an inclination to twist, either the packer is crowding them too tightly, or else he is not selecting them with proper uniformity as to size.

In the flat pack the top and bottom layers are usually placed with the stem up and down respectively. The reason is that the stem end of an apple possesses the larger surface to bear the pressure of the board; and as the apples are usually placed on the fruit stand calyx end up, the latter end is especially to be guarded

from bruises. Formerly it was deemed good packing to allow layers of both the cheek and the flat pack in the same box. It is found to be unnecessary, however, and is undesirable, because it usually necessitates two different sizes of apples for the same box. Most apples are not the same in transverse diameter as from calyx to stem. Apples are never turned with the stem toward the side of the box. In the effort to make the pack tight from end to end the cheeks would easily bruise. With the cheek pack, a neater package is made by turning all the stems in the same direction. Some packers always pack with the stem toward them, and others with the stem away from them. Some packers occasionally reverse the end apple of a row to make it fit better.

For exhibition purposes the stems are sometimes pointed from either end toward the center of the box in the two-two cheek pack. In sizes 80 and larger, and less frequently in the larger sizes of the three-two pack, the top layer is sometimes arranged in the "stem to cheek," or "interlocking" pack, in order to present a solid surface of color. (See Fig. 34.) However, this necessitates a much larger apple for the top layer, and is likely to produce stem punctures. It is therefore not desirable commercially, and is not in favor with many of the judges at the apple shows. Another method of obtaining a solid surface in three and one-half tier

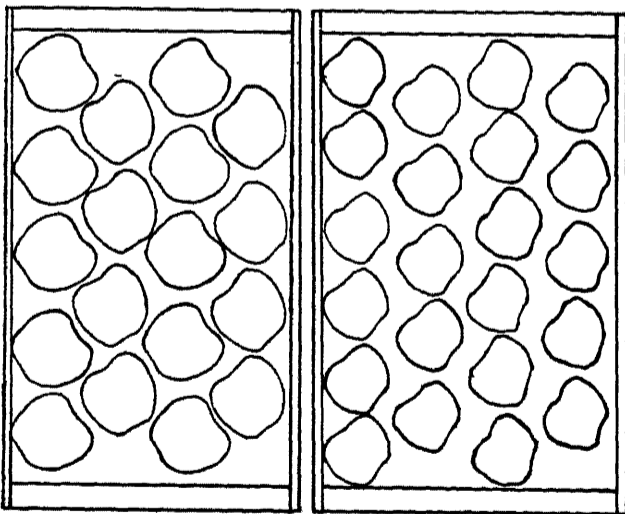

Fig. 34. Stem to Cheek, Or Interlocking Pack, Not Commercial.

Fig. 35. Stems pointing diagonally toward side of box for obtaining solid surface in the large apples packed two-two. Not Commercial.

show apples is to place the top layer with the stems pointing diagonally toward the side of the box, as in Fig 35. Apples placed thus do not stay placed, however, and the practice is not a commercial one

REQUISITES OF A GOOD APPLE PACK

The requisites of a good apple pack are (1) a proper bulge, (2) height at ends, (3) uniformity of size, (4) firmness, and (5) neatness, including a good alignment.

Bulge and Height at Ends

The general rule for the bulge on a box of apples is from one inch to one and one-half inches, top and bottom combined, after the box is nailed up. The boxes, then, are always piled on their sides. The reason for the bulge is to furnish pressure for keeping the apples tight and avoiding injury from their being shaken about in handling. Formerly, more bulge was given, but to the detriment of the apples. Apples of a soft variety, or apples packed or repacked after they have begun to mellow cannot be given the maximum bulge. Double tops and bottoms are frequently used for export apples in order to prevent injury from rough handling in the nets employed for loading and unloading at the docks. In this case but little bulge is given, the top of the curve not rising above the box cleats, in order to prevent bruising from the stiffness of double boards in nailing up. In all cases care should be taken to have the crown even, so that all apples in the top layer receive equal pressure from the lid, and none bruised. Likewise the bulge on the top and the bottom should be made equal by the use of a proper nailing press.

The subjects of bulge and height at ends are closely related. If the pack is firm, the size uniform, and the proper style of pack employed for the size and shape, the height of the crown will usually be correct. Attention, then, will have to be paid to keeping the ends low. The inclination is toward too great a height at the ends, with bruised apples as the re-

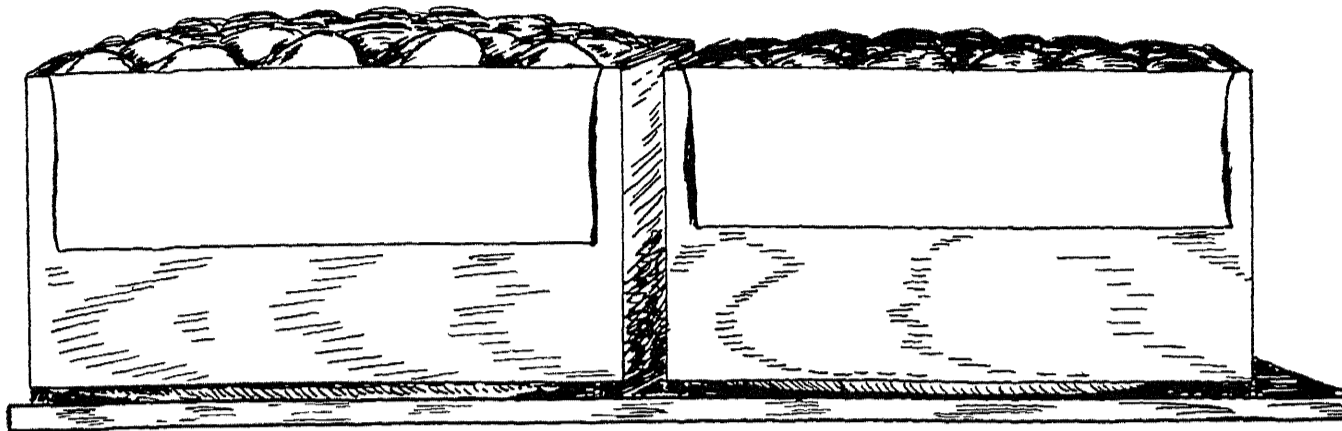

Fig 36 Showing Proper and Improper Crown That to the Left is Too High.

sult, rather than toward the opposite mistake. The ideal is a firm pack with the end apples flush with the box heads. However, in a loose pack the end apples, as well as the whole crown, can be allowed to come higher, without fear of bruising from the lid. As previously stated, the height of the whole pack can be regulated by the style of pack used, with reference to the direction in which the stems point. The proper relation of the height of end and the height of crown is obtained by other means. In the flat pack this apparently comes of its own accord. This is because the spaces at the end of the box in this pack are larger than the interstices between the apples, and they allow the end apples in the layer above to slip down lower. Sometimes, however, taller apples will have to be selected for the middle, and lower ones for the ends.

In the cheek pack three methods for lowering the ends of the pack can be employed. (1) Advantage is taken of any lopsidedness in the apples. Those apples in the middle of the box (from end to end) are placed with their greatest transverse diameter extending from top to bottom, and those in the end with it extending from side to side. (2) One or two rows across the end of the box in as many layers as necessary are turned flat. This is usually at but one end of any one layer, the layers alternating as to the end in which the apples are turned. This method is avoided by many packers because it makes the pack irregular, but it is to be preferred to bruised apples. Many now use a simplified form of this method, simply tilting toward the

opposite end of the box, in the second layer from the top, the apple on the end of the row that does not touch the end of the box, turning it only far enough to allow the cheek of the end apple in the top layer to fit into the cavity-cup or the basin-cup of the tilted apple. An especially flat apple is selected for the one to be tilted. (3) The ends are packed a trifle loose. Care will have to be taken in using this method that the apples next to the ones against the lower head of the box are pushed toward the opposite end of the box as far as they will go. Otherwise their slipping down toward the lower head will prevent the end apples in the next layer above from sinking their proper depth by reducing the size of the pockets into which they are to fit. In placing

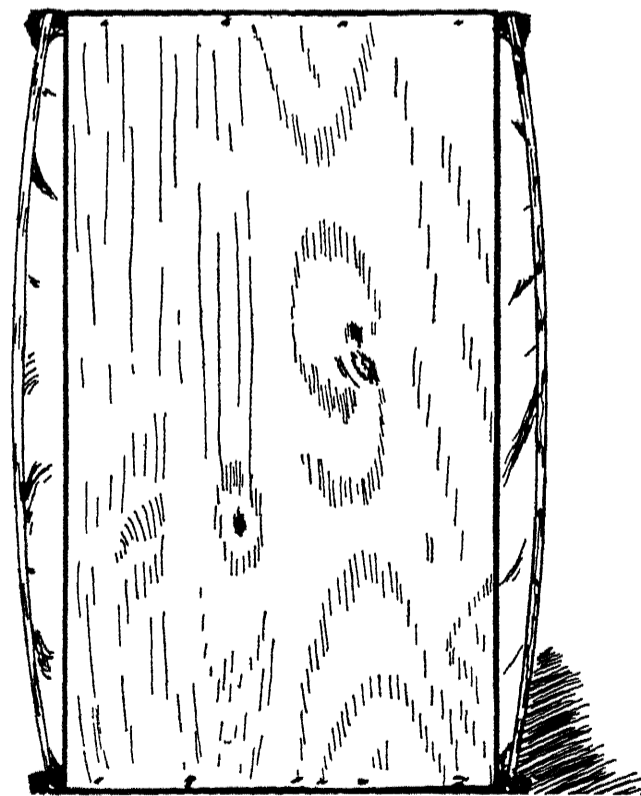

Fig. 37 Showing a Proper Bulge on Box of Apples

either end apple of a row into the box, it can be put in, not in a perpendicular position at first, but tilted slightly toward the middle of the box, pressing it then into place by turning it up perpendicularly to the bottom of the box. This tends to press the apples in the layer underneath toward the middle of the box, heightening the crown, and allows the end apple that is being placed to sink lower into its pocket, lowering the end of the pack. Care will have to be taken in performing this operation not to press so hard as to bruise the apples. One frequently hears it stated that the ends are to be kept low by the use of smaller apples at the ends. This will bring the desired result; but it is unnecessary and undesirable, because breaking the uniformity of size.

Uniformity of Size

Under our present system the packer usually has some sorting for size to do after the apples have left the graders and come into his hands. Here he needs a quick and exact eye. Regardless of his natural ability, he also usually finds that only practice enables him to do satisfactory work rapidly.

It is not usually supposed that separate packs are to be made for all the possible sizes, or counts, of a variety. As a general rule, the smaller the apple, the greater the difference allowable in the number of apples to the box.

Inability or carelessness in grading for size sometimes causes packers to commit what is jocosely called "the unpardonable sin in apple packing," or as it is more technically expressed, "to break the pack." By this is meant that the packer constructs a layer containing too many or too few apples, thus confusing the count. For example: suppose he has packed four layers of his box a three-two pack five-five long, and for the top layer selects smaller apples, making the rows six-five long. The bottom four layers are four-tier apples, 125 to the box. The top layer contains four and one-half-tier apples, 138 to the box. In this case the value of the apples in the top layer may be from 10 to 50 cents less per box than the ap-

ples in the other layers. But the number stamped on the box will be determined by the number in the top layer. The box will be stamped 138, classed and sold as a box of four and one-half-tier apples, and the grower will not receive due payment for four-fifths of the box. To guard against breaking his pack, the packer must be sure that the center of every apple above the first layer fits exactly over the interstice between the apples directly underneath.



Fig. 38. Example of Broken Pack. The apples are not kept directly over the spaces beneath. This confuses the count. Usually due to lack of uniformity in size. (New York (Cornell) Experiment Station Bulletin 298).

Firmness

The instructions to packers of the Hood River Apple Growers' Union, Oregon, for the year 1912, state: "A swell on the box does not mean necessarily a tight pack; the apples must be tight from side to side and from end to end. The Union wants a tight pack, but not so compact as to bruise the apples." The custom of a judge at a box apple competition, in passing upon the point of firmness, is to try to wiggle with his hand the apples in each layer of the box as he goes through it. He does not want to find one apple in the box that his hand can disturb. The ideal for firmness is that the box without the cover can be set on end and the apples not fall out. An increasing number of persons do not agree with this view on the point of firmness, however, believing that a pack may be loose and still be full, which they further believe is all that is necessary. Their argument is that if there is a large interstice between the apples in any layer, it only means that the apple directly above

the interstice is going to fit down closer into it, and that there will be no less weight to the box. Some of them further state that the loosely packed box will be handled with the fewer bruises. Still the fact remains, so the others would affirm, that the tight pack makes a better impression upon the trade.

Neatness

So precise have many farmers and dealers become in their estimation of the nature and value of consumers' fancies, that they analyze them and translate them into sense impressions, and give numerical weight to these impressions more accurately than they could guess the weight of a hog or the number of bushels in a corncrib.

"The growing, the preparing, and the marketing of many of the products of the farm are becoming questions of art and psychology. Less do people eat to live than they live to eat, and yet when they buy food, they buy it often not primarily for the gratification of taste, but upon the testimony of the eye, which is pleased with form and color, and upon the perception of odor, while, if the consumer were reared in the country, perhaps his choice is determined by the farm-bred fancies of a happy youth.

"What set of nerves shall have the preference in determining the purchase of a farm product, the optic or the gustatory? Shall a thing be pretty, or delicious; and, since the sense of smell must also be consulted in some cases, is it of much consequence whether it is pretty or delicious? The seller has much more definite information with regard to these questions than the consumer; although it is the consumer who makes the choice, he is induced to do so by the seller's subtle knowledge of his fancies, which need not be and often are not either sensible or reasonable, but, on the other hand, often verge upon the notional, and seem superfluous to an unsophisticated farmer."*

* "Consumers' Fancies." Geo. K. Holmes, Yearbook of Department of Agriculture, 1904.

With the above statements as a foundation, if the grower or packer will but stop to reflect upon his own observations and experience, further argument is unnecessary to establish in his mind the desirability of a neat apple package. Mr. Carl W. Kimball, president of the National League of Commission Merchants, states that he regards neatness, together with firmness, as the most important requirements of a good pack. The points to be looked to are a clean, bright box, careful nailing, orderly stamping, a tasty label, smooth wrap, with no rough edges of the paper showing, and a true alignment. A good alignment depends on the equal spacing of the apples touching the lower head of the box in any layer, on keeping the stem end of the apples pointing straight toward the end of the box, and on uniformity of size.

PACKING HOUSE MANAGEMENT

For the apple product of a section to gain favor in the markets of the country and then retain it, first a standard of grade and pack for the product must be established, and second this standard must be uniformly maintained. It has been comparatively easy for the apple districts of the Northwest to formulate rules covering the various grades, but difficult for them to maintain any standard uniformly. This has been due partly to the increase in the number of persons engaged in the industry beyond the power of the older growers to instruct the newcomers as to definitions and methods. There has also been the danger that the faulty output of the indifferent and dishonest would act to annul the efforts of the painstaking and conscientious and give the whole producing district a bad name. This condition, in fact, did evolve in some instances. In one case a certain house, which any man would be proud to say handles his product, was driven permanently from a certain district by the extreme carelessness or flagrant dishonesty of a single grower in putting up the pack of one season. A member of the firm stated that they could not afford to do business in a community which tolerated such practices.

These things, then, have been factors toward the establishing of growers' associations, not the least function of which is to maintain the standards of grade and pack. The methods by which the associations have gone about accomplishing this end have been, generally speaking, two, inspection and direct management. Inspection, when it takes the exclusive form of examination of the product after it is packed ready for market, is rarely an entire success, being a corrective rather than a preventive measure. Where the inspector visits the packing house of the various growers, examining the sorted apples before they are packed and giving instructions where necessary, the case is a step in advance. Although here the workers are responsible to the grower, and after the inspector leaves may receive conflicting orders from their employer. The best system for securing the desired result is now conceded to be one in which the selling agency takes entire charge of grading and packing the fruit, the workers being responsible only to the agency. This system is carried on under two forms, one where the fruit is graded and packed in the packing house of the grower, but with a foreman and crew employed and furnished by the dealer or association (perhaps the grower not being

allowed even to help in the work), the other where the work is done in the warehouse of the agency, or in a building built and equipped by it especially for use as a packing house, and with a force likewise responsible only to the management of the agency. An example of an association operating successfully under the first form is the Hood River Apple Growers' Union, of Hood River, Oregon; an example of one operating under the second form, the North Fork Fruit Growers' Association of Paonia, Colorado. This latter maintains several packing plants conveniently located throughout the district, also temporary camps for accommodating the employees. Several associations throughout the Northwest practice more than one system, maintaining a packing department for the benefit of those who for any reason do not wish to pack at their orchards. The central packing house is especially adapted to a community of small orchards, where none of the growers can afford singly an adequate house and system for handling the crop.

The object sought in the management of the packing house, whether private or cooperative, is a perfect product at a minimum cost. A most important, though difficult, fact which the apple growers of the Northwest have had to learn, is that



Fig. 39. Pear Pack.

—*Courtesy Rogue River Valley Fruit Growers' Union.*

the high quality of output at which they have aimed can be secured only by the distinct separation of the processes of grading and packing. In the districts bearing the enviable reputations for their apple product, however, this fact has been recognized and the division made. It is doubtful if a packer exists, who, under the piecework system and at a rate of payment possible for the grower to give, will pay the attention to both processes at once such as is required to satisfy the present demand as to grade and pack caused by the increasing competition in the apple market. This does not mean that the packer should not still be held responsible for the grade as well as the pack, however. On the contrary, in the most progressive districts he is so held responsible and in an actually operative manner, by withholding his pay until his work is accepted by the proper inspector, at which time, of course, his responsibility ceases. As is but just, he is at the same time given the right to refuse to pack apples not properly sorted. The Hood River Apple Growers' Union has been the pioneer and the leader in its efforts to secure a perfect product through a strict management of its packers.

Various methods for controlling the packer under various conditions, in order to secure a good quality of output from him, including those just mentioned, are enumerated herewith: (1) paying by the day, rather than by the piece (which practice has rarely anywhere been continued long, because of the lack of incentive for the packers to work at a speed profitable to the employer); (2) separation of the processes of grading and packing; (3) classifying the packers according to the rate of speed at which they can do good work, and setting a limit for the output in number of boxes per hour for each class; (4) making the packer financially responsible by withholding his pay until his boxes have been accepted by the proper inspector; (5) granting the packer the right to refuse to pack apples not properly sorted; (6) paying the packer at a fair rate for ap-

ples, not culls, which he sorts out which are not of the grade he is packing (besides helping to keep the lines between the grades distinct, this serves as a check upon the grader); (7) requiring each packer to insert a slip into each box which he packs, containing his number, the definition of the grade which he is packing, and a request that the customer return the slip with a complaint if the pack is not satisfactory or the grade not up to standard. To identify each packer's boxes, most associations furnish their packers with number stamps upon the deposit of the proper price, the number to appear on each box the packer puts out.

The problem of expense in the packing house has been an increasing one, due in a large measure to the increasing exactitude of the standards of grade and pack, together with the increase of the apple crop beyond the supply of competent labor to care for it. Economy can be secured only through the items of materials and labor. As to the first, little improvement can be looked for immediately. It should be remembered in the preparing of any article for market, that cheapness and saving do not necessarily mean economy, and that expense borne merely to impress the consumer frequently brings excellent returns.

Most of the economy in the packing house must come through the saving of labor. The tender nature of the apple, as compared to the orange, deferred until recent years the devising of machinery for handling the former fruit such as is used for the latter. It would seem that now, however, under the increasing necessity for economy along every line, machinery and devices for handling the apples are to be the chief factors toward gaining the desired end.

Some really worthy effort has been expended in trying to perfect these various machines. The wiping machine saves hand work. The combined sorting and packing table, the sorting belt, the pro-

vision made for sorting at some of the sizing machines, all save two handlings of the apples over the method of sorting from box to box by hand, then piling the boxes of sorted apples to be handled again when taken to the packing table. Where a large quantity of the fruit is concerned, and where it has to be trucked any distance between operations, this item is especially important. These same machines and devices also render it unnecessary to pick up each apple separately and turn it over in the hand for examination in sorting, the same result being accomplished by rolling over several of the apples at once with the outspread fingers. Perhaps not the least advantage in the use of any machine is that it sets a pace for the workers. There is nothing at which a man can waste more time than at sorting by hand, with the opportunity afforded for making slow decisions. To be sure, expert and alert help is required for sorting at any of these machines or devices, and one cannot expect to find a man fit for the job at the price of ordinary labor. At that, their use has been estimated by one of the largest dealers in the State of Washington—a man who has used one both on his own ranch and in one of his warehouses—to save from 30 to 70 per cent of the usual cost of sorting. In addition, the sizing machine should make possible the employment of persons for packing, who, lacking an eye for size, could not otherwise be employed for the purpose, and will tend toward reducing the competition among growers in the market for packers. Finally, packers can be expected to work for less per box when packing from the trays of a sizing machine, where they have to handle but one size at a time, or at the most two.

In a few instances sorters have been paid by the box rather than by the day for their labor, which has greatly cut down the cost; but the difficulty of securing careful work under this system would cause it to be frowned upon by most growers. An appreciable amount of

time can be saved in sorting by the elimination of all but two grades, No 1 and No. 2, with only a few standard varieties allowed in the first. Every added box into which the sorter must sort reduces by so much his output for the day. The Washington State Horticultural Association, at its meeting in 1913, passed a resolution to the effect that "the price paid for packing apples, prunes and pears should be one cent per box less, and for packing peaches one-half cent per box less, to packers who have to be waited upon, than is paid to those who wait upon themselves." Although the principle involved is probably just, still no change can be expected except from a change in economic conditions. In one other way labor can be saved in the packing house—by a convenient arrangement of the house itself and of the packing furniture. Although this fact seems self evident, still a trip through any apple producing district at packing time impresses one that many times the fact is lost sight of by the grower. Things were not prearranged before the rush began. It will pay to give attention to so little a matter as the arrangement of the rubber stamps convenient for the nailer

It is stated that persons grading by hand can be expected to assort an average of about ninety loose boxes of apples per ten hour day, when working by the day. When working by the box, they will run the number up to one hundred and fifty or over unless watched. Packers will do good work at from thirty to one hundred boxes a day, depending on the person and the conditions. From five to seven and one-half cents per box are paid for packing, sometimes including board, the price varying according to the supply of packers and the conditions under which they work. The average between the cost of putting up apples, also pears and peaches, in each of two representative fruit growing valleys of Colorado, as given by a co-operative association in each, is itemized in the following table:

	Apple	Pear	Peach
Cost of box	\$ 125	\$ 1125	\$ 0725
Making box	009	009	006
Paper	0075	0188	0125
Nails	005	005	0035
Nailing up	0063	0063	0042
Packing and sorting	055	055	0275
Overhead expense	04	04	02

The average between the cost of putting up apples, also pears and peaches, in the two largest fruit growing districts in the State of Washington, as given (in one case unofficially) by the chief cooperative association operating in each district is itemized in the following table

	Apple	Pear	Peach
Cost of box	\$ 105	\$ 10	\$ 0575
Making box	01	01	0075
Paper.	0272	0272	016
Nails	00359	00359	.0023
Nailing up	01	01	0063
Packing	055	055	03
Sorting	058	0525	.

In addition to this is an overhead expense varying greatly with conditions. Most of the above items in each table must necessarily be but approximately correct, and will vary from year to year. On an average, 50 pounds of wrapping paper are required for one 100 packed boxes, seven pounds of lining paper and 16 pounds of cardboard.

Of course in any case the problem of packing house management is one dealing more or less with the fact of personality, and the success or failure of any one system or method depends in a

large measure upon the character of the directors and overseers as well as of the workers themselves.

JUDGING AT APPLE SHOWS

Judging apples at the fruit exhibitions is one of the important features of the fruit business, since it is by this means, or through this channel, that many growers receive education and obtain their ideals of what constitutes proper grading, and estimates of the relative value of fruits when judged by a perfect standard.

Of course, we understand that the word



Fig. 40. Peach Packing Scene. Note the arrangement of packing benches and paper hods.

'perfection' is a relative term and that nothing known to us is absolutely perfect. But in the sense in which we use the word it means lacking nothing that is desirable or essential to complete development or the highest attainable qualities." Since some apples are of higher quality than others, as is the case of the Spitzenburg as compared with the Ben Davis, it seems necessary to give a definition something like this: "Lacking nothing requisite to its kind." In this case each and every variety of apple would be judged in accordance with the ideals of the judges as to the standards of perfection of the variety being judged and not by standards of excellence of other varieties.

Exhibitors often inquire, "What is a perfect standard?" "Who has the right to fix a standard which will determine the perfect specimen?" "Who is authority on this subject?"

It is not easy to answer all the inquiries made as to why a particular exhibit is given a premium while another which, to the unpractised eye, looks as good or better, is not given an award. It is important, however, to state that the standard is set by the best pomologists of the American Pomological Society. These pomologists consider that certain varieties of apples have certain distinguishing characteristics. These characteristics were determined, perhaps, by the nature of the original tree, but no matter how they came to be fixed characteristics they are nevertheless features which differentiate it from other types. After a type is established, described by pomologists, and comes to be known as possessing certain qualities, the problem of the judge is not so much concerned with the quality of the apple as compared with other varieties, as how nearly it approaches the perfect type of this variety. In other words, Is it "true to type?"

Further, there is a tendency for apples to vary on account of soil, climate, sunshine, elevation and other factors which enter into their environment. After all the factors are considered pomologists generally select the apple most like the orig-

inal type. It has been the writer's good fortune to attend apple judging contests during the last twelve years and he would earnestly recommend that in every important contest there be appointed three judges instead of one. The reason is clear when it is remembered that so many factors enter into the question as to what constitutes a perfect type of any particular variety.

Since the market value of apples enters so largely into the question of apple growing and determines in so great degree what will be the grower's profit, it seems to me that of three judges two should be commercial fruit dealers and one a scientific pomologist. The pomologist is likely to have in mind the hereditary traits of the apple while the commercial dealer will have in mind the selling quality of the fruit. Since the decisions are educational and since the education should be of such a character as to produce the highest values possible with a given amount of labor, the decisions of the dealer are of more practical value than those of the pomologist. The writer has in mind several contests where the competition was so keen that in order to reach a conclusion it became necessary to remove all the apples from the boxes and to pass upon each apple separately.

Where the decisions have been rendered by three judges, even where the contest was close, the contestants have seldom questioned the accuracy of the conclusions. But where the contest is close and the matter is decided by one alone, there is almost always dissatisfaction.

ROBERT MORGAN

Suggestions for Score Card for Exhibitions of Boxed Apples

The score card here suggested was arranged by Frank Kinsey, author of the article on Apple Packing in this work, who has had a wide experience East and West in preparing boxed apples for exhibition. The suggestion is concurred in by C. J. Sinsel, of Boise, Ida., well known as an expert in these matters. The score card of the International Apple Show is also given as the "Spokane Card."

	Spokane Card	Recom- mended
Quality	20	---
Color	20	20
Contour	---	20
Size	10	10
Uniformity	10	10
Freedom from Blemish and Dirt	20	20
Pack (total)	20	20
Total	100	100

Items of Pack

Box	---	---
Style of Pack	---	4
Height of Ends.....	4	4
Bulge	4	4
Firmness	---	4
Neatness	---	4
Alignment	4	---
Compactness	4	---
Attractiveness and Style	4	---

"Quality" is omitted from the suggested card for the reason as, ex-President Kimball, of the National League of Commission Merchants suggests, that, in boxed apples, "quality" is a combination of all the other items. "Quality" can be used only in accordance with the American Pomological Society ratings on account of the difference in maturity of different lots due to difference in locality where grown.

An Eastern representative of a Northwestern marketing agency says that what the dealers look for in Northwestern apples is color and contour. The old card has no place for type, form or contour, the latter term referring to *symmetry*, regardless of whether the specimen is true to type or not. Uniformity is not the place under which to consider contour since uniformity refers to size only.

"Firmness" is preferable to "compactness" because the latter could be construed to mean a pack with no holes, necessitating irregularity in the pack and the use of the "stem to cheek" pack, or more than one shape of box to accommodate the different sizes of apples. Most judges take "compactness" to mean "firmness" or tightness, so why not "firmness" on the card?

Alignment is omitted from the suggested card, to be considered under neatness. It really depends upon proper uniformity and style of pack.

Under the old card some judges did not consider neatness, giving a lot perfect on the last item of the card if the style of pack was correct. Under the old card the 3-2 pack could be scored imperfect because not so attractive as the 2-2, whereas it is accepted commercially and cannot be avoided because of variation in size. The style of pack depends, not on attractiveness, but on the use of a uniform package and on maintaining a perfect condition of the apples. A more attractive pack can be secured by the use of two sizes of box but this is not desirable commercially.

The above is on the assumption that the Northwest standard box is to be used.

ORCHARD COSTS AND MANAGEMENT

In the tables under this heading reliable information from many sources is given. Conditions are so different in the various sections of the United States, that an expense table in one section would furnish inadequate information of the costs in another. In some sections, there is the cost of clearly heavily timbered lands; in others, the cost of irrigation; in some there is the initial cost of high-priced lands; but they are high-priced, because they seem to the owners to possess certain advantages not found in sections where lands are cheap.

Clearing Timber Lands—Orchard Costs First Two Years

The information contained in this article applies to the logged-off lands of the timber belt in Northeastern Washington and Northern Idaho.

Character of Timber: Timber on the lighter soils is chiefly pine and on the heavier soils runs more to fir and tamarac, the logged-off land growing up to a heavy covering of second growth timber, laurel, willow and kinnikinic.

Soil: Soils vary from light sandy to clay loams. When first cleared it is brownish yellow but turns dark under cultivation.

Rainfall: Rainfall is from 20 inches up (see Frost and Precipitation Tables for special localities in Washington and Idaho) and is sufficient for cereal crops



Fig. 1. Piling Stumps with a Derrick before Burning.

under dry farming methods. Irrigation is needed for intensive farming.

Methods of Clearing: Small timber is slashed and underbrush grubbed and burned. It is better to do this a year in advance of pulling the stumps but in practice it is usually done just ahead of the clearing crew. Dynamite is used to split and loosen the stumps, which are

then pulled with horse pullers. They are then piled with a derrick and burned. The land is then worked down with discs and spring tooth harrows. The smaller roots and rubbish are gathered with horserakes and burned. Leveling is done with fresno scrapers. Cost of clearing runs all the way from \$37.98 to \$139.00 per acre.

Table No. 1—Spring, 1910

Cost of planting 628 acres, spring of 1910:

Day labor cost \$2.50 per day; man and team, \$5.50 per day. Cost of trees not included in any table.

	Staking		Cost per Acre	Holes		Cost per Acre	Setting		Cost per Acre	Total Cost Acre
	Cost	Acre		Cost	Acre		Cost	Acre		
1.....	\$172.55	160	\$1.08	\$101.46	160	\$0.62	\$532.75	160	\$3.34	\$5.04
2.....	48.81	40	1.22	32.40	40	.81	128.97	40	3.22	5.25
3.....	31.35	20	1.57	13.09	20	.65	51.01	20	2.55	4.77
4.....	55.18	40	1.38	36.00	40	.90	105.55	40	2.64	4.92
5.....	85.66	32	2.68	43.12	32	1.35	100.35	32	3.13	7.16
6.....	78.95	49	1.61	71.87	49	1.47	182.06	49	3.80	6.88
7.....	63.32	60	1.05	30.50	60	.51	202.51	60	3.75	5.31
8.....	60.25	40	1.51	28.50	40	.71	153.50	40	3.83	6.05
9.....	107.25	147	.82	39.40	147	.27	363.19	147	2.46	3.55
10.....	88.75	40	2.22	35.33	40	.89	129.75	40	3.24	6.35
	\$792.07	628	\$1.26	\$431.67	628	\$0.70	\$1,949.64	628	\$3.10	\$5.06

Total \$5.06 per acre or \$0.062 per tree.

Table No. 2—Fall, 1910

Cost of planting 2 055 acres fall of 1910 Wages as in Table No 1

	Staking		Cost per Acre	Digging		Cost per Acre	Setting		Cost per Acre	Total Cost Acre
	Cost	Acres		Cost	Acres		Cost	Acres		
1	\$208 25	160	\$1 30	\$ 93 95	160	\$0 58	\$136 65	160	\$0 85	\$2 73
2	61 50	50	1 23	15 75	50	31	65 00	50	1 30	2 84
3	44 07	30	1 47	22 54	30	75	28 88	30	96	3 18
4	14 65	10	1 46	8 28	10	83	9 62	10	96	3 25
5	168 25	120	1 40	89 27	120	74	159 30	120	1 33	3 47
6	169 65	100	1 70	33 95	100	34	100 24	100	1 00	3 04
7	230 85	160	1 44	123 65	160	77	198 05	160	1 24	3 45
8	74 00	40	1 85	32 88	40	82	82 85	40	2 07	4 74
9	189 20	130	1 45	104 18	130	80	184 45	130	1 42	3 67
10	132 90	95	1 39	75 82	95	79	145 47	95	1 53	3 71
11	137 75	100	1 38	53 18	100	64	182 02	100	1 82	3 84
12	195 30	140	1 39	124 10	140	82	216 64	140	1 54	3 85
13	28 55	20	1 43	24 25	20	1 20	32 72	20	1 63	4 26
14	59 50	40	1 48	21 58	40	54	79 95	40	2 00	4 02
15	163 10	130	1 25	113 19	130	87	340 66	130	2 62	4 74
16	86 00	50	1 72	50 66	50	1 01	53 00	50	1 06	3 79
17	216 80	130	1 67	74 85	130	57	215 38	130	1 66	3 90
18	185 45	140	1 32	101 75	140	73	216 33	140	1 55	3 60
19	154 00	100	1 54	77 72	100	78	116 63	100	1 16	3 48
20	229 30	160	1 43	142 21	160	89	66 45	160	42	2 74
21	153 75	110	1 40	76 31	110	69	202 10	110	1 84	3 93
22	56 70	40	1 62	22 95	40	57	45 90	40	1 15	3 34
	\$2,959 54	2,055	1 44	\$1,483 52	2,055	\$0 72	\$2,878 23	2,055	1 40	3 56

Total, \$5 06 per acre or \$0 04 per tree

Table No. 3—Spring and Fall, 1911

Cost of planting 1 907 acres spring 1911 Labor cost as in Table No 1

Prun- ing Roots	Staking		Cost per Acre	Digging Holes		Cost per Acre	Setting		Cost per Acre	Total Cost Acre
	Cost	Acres		Cost	Acres		Cost	Acres		
\$ 25	\$152 00	160	\$0 95	\$113 72	160	\$0 71	\$177 85	150	\$1 18	\$3 09
25	20 00	20	1 00	12 50	20	63	23 00	20	1 15	3 03
25	89 60	97	92	65 75	97	68	88 90	97	92	2 77
25	40 00	40	1 00	26 00	40	65	47 20	40	1 18	3 08
25	148 80	160	93	120 66	160	75	118 20	160	74	2 67
25	179 05	138	1 30	50 75	98	52	118 99	40	2 97	5 04
25	26 70	30	89	13 46	30	45	28 20	30	94	2 53
25	130 00	130	1 00	138 35	130	1 06	81 80	130	63	2 94
25	140 35	150	93	105 49	150	70	175 54	150	1 17	3 05
25	114 70	120	95	69 94	120	58	126 00	120	1 05	2 83
25	180 55	160	1 13	108 34	160	68	221 12	160	1 38	3 44
25	41 25	40	1 03	49 25	40	1 23	80 50	40	2 01	4 52
25	161 00	160	1 00	110 96	160	69	233 12	160	1 46	3 40
25	20 00	20	1 00	15 25	20	76	20 00	20	1 00	3 01
25	100 25	110	91	62 00	100	62	115 80	60	1 93	4 09
25	149 11	112	1 33	62 25	92	68	109 10	70	1 56	3 82
25	160 25	160	1 00	124 00	150	83	171 95	140	1 22	3 30
25	153 30	160	96	98 23	160	62	286 72	160	1 79	
25	157 90	160	99	111 59	160	69	211 72	160	1 32	
\$0 25	\$2,125 56	2,127	\$1 00	\$1,396 49	2,047	\$0 68	\$2,435 71	1,907	\$1 28	\$3 21

Total \$3 21 per acre or \$0 04 minus per tree

Table No. 4—Spring, 1912

Cost of planting 1,504½ acres spring, 1912: Day labor cost \$2.25 per day; man and team, \$5.00 per day.

	Pruning Roots		Cost per Acre	Staking		Cost per Acre	Digging Holes		Cost per Acre	Setting		Cost per Acre	Total Cost Acre
	Cost	Acres		Cost	Acres		Cost	Acres		Cost	Acres		
1 ...	\$44.40	120	\$0.37	\$106.20	120	\$0.89	\$64.13	120	\$0.53	\$110.61	120	\$0.92	\$2.71
2 ...	3.70	10	.37							9.22	10	.92	
3 ...	24.08	65	.37	58.50	65	.90	36.41	65	.56	59.10	65	.91	2.74
4 ...	22.20	60	.37	54.00	60	.90	33.71	60	.56	54.99	60	.91	2.74
5 ...	4.44	12	.37	10.80	12	.90	7.87	12	.66	12.82	12	1.07	3.00
6 ...	37.00	100	.37	90.00	100	.90	59.00	100	.59	119.26	100	1.19	3.05
7 ...	44.40	120	.37	108.00	120	.90	54.34	120	.45	101.69	120	.85	2.57
8 ...	33.30	90	.37	81.00	90	.90	56.42	90	.63	65.36	90	.73	2.63
9 ...	40.70	110	.37	22.05	22	1.00	31.24	62	.50	94.23	110	.85	2.72
10 ...	7.40	20	.37	18.00	20	.90	7.87	20	.40	20.05	20	1.00	2.67
11 ...	9.15	25	.37	13.50	15	.90	13.50	25	.54	18.50	25	.74	2.55
12 ...	37.00	100	.37	52.20	58	.90	26.59	58	.46	92.77	100	.93	2.66
13 ...	11.00	30	.37	31.50	30	1.05	13.55	30	.45	28.00	30	.93	2.80
14370	10	.37				6.50	10	.65	9.00	10	.90	
15 ...	18.50	50	.37				6.44	10	.65	46.00	50	.92	
16 ...							2.35	3	.78	27.90	30	.93	
17 ...	33.30	90	.37	52.20	58	.90	48.15	68	.71	82.31	90	.92	2.90
18 ...	59.20	160	.37	144.00	160	.90	93.66	160	.59	155.81	160	.98	2.84
19 ...	37.92	102½	.37	92.25	102½	.90	66.52	102½	.65	98.42	102½	.96	2.88
20 ...	6.40	20	.37				6.76	10	.68	20.75	20	1.00	
21 ...	29.60	80	.37	72.00	80	.90	42.30	80	.53	72.57	80	.91	2.71
22 ...	37.00	100	.37	90.00	100	.90	42.86	100	.43	102.48	100	1.02	2.72
23 ...	\$544.39	1474½	\$0.37	\$1096.20	1212½	\$0.90	\$720.17	1305½	\$0.55	\$1401.84	1504½	\$0.93	\$2.75

Total \$2.75 per acre or \$0.033 per tree.

Table No. 5-A—1912

Itemized cost of discing, plowing, spraying, cultivating and, where necessary, re-planting on 6,505½ acres. This includes 50 acres four-year-old trees, 904 acres three-year-old trees, 2,047 acres two-year-old trees, 2,604½ acres one-year-old trees.

Average cost was \$5.22 per acre. To this should be added \$1.22 per acre for overhead charges.

Acres	Discing 200	Harrowing 201	Plowing 202	Pruning 203	Spraying 204	S. Horse 208	Hoeing 209	Replanting 194	Total
1 ... 117 1 year ...	\$165.46	\$138.65	\$231.81	\$ 15.93	\$ 6.95	\$ 16.32	\$ 30.53	\$106.66	\$712.31
2 ... 120 1 year ...	137.94	103.58	254.56	7.90		32.37	27.32		563.67
3 ... 160 1 year ...	296.23	269.02	467.50	15.07	17.90		96.65	165.08	1,327.45
4 ... 160 2 years ...	188.26	265.75	280.50	2y. 30.75	21.17	24.00	105.11	24.61	940.15
5 ... 65 1 year ...	101.42	50.25	126.81	9.00	1.08	25.98	18.83		333.37
6 ... 100 1 & 2 years	54.02	163.99	150.37		13.66		30.97	21.72	434.73
7 ... 12 1 year ...		14.00	32.24	1.25		2.25			49.74
8 ... 50 2 years ...			91.25	11.80	11.40	85.54	17.01	7.95	224.95
9 ... 40 2 years ...			82.50	15.75	19.20	85.83	24.00	42.00	269.28
10 ... 100 ...		142.22	255.50	30.00	9.00	21.15	26.32		484.19
11 ... 120 ...	161.82	234.40	326.81	19.75	5.55		22.25		770.58
12 ... 120 ...	188.33	203.02	324.36	6.90	5.55		18.50	15.75	762.41
13 ... 160 ...	225.46	153.62	439.69	9.53	11.10		74.73	33.99	948.12
14 ... 160 ...	218.52	216.32	419.78	7.80	11.10		89.75	77.38	1,040.65
15 ... 160 ...	175.34	193.65	394.99	19.75	22.87	23.21	90.11	86.37	1,006.29
16 ... 160 2 years ...	97.65		272.74	18.75	26.54	159.15	112.13	42.77	729.73
17 ... 120 ...	108.29	146.64	285.39	10.00	9.93	2.25	82.14	71.78	716.42
18 ... 160 2 years ...	84.99	174.78	338.43	19.00	36.26	68.51	63.54	90.51	876.02
19 ... 160 2 & 3 years	84.74	246.98	236.78	64.83	87.76	109.14	160.22	22.05	1,012.90
20 ... 70 ...	26.73	60.49	116.12	19.00	26.83	20.92	92.67	27.73	380.49
21 ... 112 ...	108.90	240.95	251.47	23.36	40.10	30.02	167.62	34.31	896.72
22 ... 160 ...	77.50	273.62	198.12	23.63	24.01	72.21	113.30	46.29	828.68
23 ... 20 ...	27.12	5.00	49.26		3.35		8.88		93.61
24 ... 160 ...	62.00	10.00	289.25	19.33	16.62	242.30	88.61	37.92	766.03
25 ... 118 2 years ...			145.00	9.90	5.30	118.45	106.26	26.87	411.78
26 ... 155 ...		8.74	333.64	20.12	10.30	187.29	114.97	29.45	704.51
27 ... 4050	36.74	25.25	7.77	19.77	14.52	83.26	15.55	203.36
28 ... 130 ...	118.00	112.00	151.13	14.75	4.45	27.24	96.73		550.05
29 ... 120 ...	126.25	115.00	142.51	11.77	8.60	77.38	42.40	25.75	555.46
30 ... 10 ...	7.75	5.00	23.50	.65			1.63	31.55	38.53
31 ... 10 ...	10.62	22.55	12.45	1.63			1.12		48.37
3349	\$2,853.84	\$3,596.96	\$6,749.71	\$429.62	\$465.67	\$1,446.03	\$2,007.96	\$1,084.04	\$18,680.55

Table No. 5-B—1912

	Acres	Discing	Harrowing	Plowing	Pruning	Spraying	S. Horse	Hoeing	Replanting 194 Acres	Total
1.....	150.....	\$ 25.50	\$ 25.06	\$136.21	\$ 74.95	\$ 72.42	\$187.90	\$114.11	\$ 23 50	\$ 659 59
2.....	160.....	15.50	136.25	140.05	35.50	12.12	152.03	49.77	50 88	592 10
3.....	144.....	36.01	93.50	322.64	8.81	1.32	97.00	75.10	6 53	640 91
4.....	70.....	93.00	89.98	2.75	5.35	82.72	56 05	11 75	341 60
5.....	150.....	40.50	65.00	225.03	20.85	11.51	127.48	89.36	37 32	617 05
6.....	160.....	250.30	46.45	45.46	42.51	7.90	88.32	130.06	17 55	628 55
7.....	160.....	12.75	15.00	118.98	58.12	179.96	127.41	128.03	16 03	654 28
8.....	160.....	233.98	86.00	268.60	14.12	99.12	61.59	16 75	770 16
9.....	160.....	187.30	50.50	171.52	27.75	1.33	117.91	84.20	18 50	659.01
10.....	160.....	284.42	154.25	412.71	42.28	60.00	51.09	44 85	1,049 60
11.....	160.....	130.19	149.72	411.10	21.88	33.62	746.51
12.....	102½.....	51.36	84.45	255.96	10.04	15.37	417.18
13.....	150.....	5.00	178.43	40.00	79.54	200.74	173.63	18 50	695 84
14.....	160.....	86.67	132.00	240.50	9.25	7.65	155.80	148.81	33 00	813 68
15.....	140.....	239.01	162.87	158.49	21.50	6.75	66.86	200.96	40 25	896 69
16.....	140.....	226.10	219.13	21.65	20.45	8.80	40.00	126.00	32 50	694 63
17.....	160.....	280.14	124.25	364.65	33.53	43.37	52.88	83.31	61 50	1,043 63
18.....	80.....	23.25	123.70	239.99	16.75	15.53	419 22
19.....	110.....	236.50	26.95	19.25	148.63	42.34	12 60	486 27
20.....	20.....	40.50	44.00	11.52	2.50	.90	9.00	12.87	20 13	141 42
21.....	140.....	65.87	70.85	307.50	27.30	6.76	34.97	36.37	17 35	566 97
22.....	160.....	203.83	101.34	316.98	17.62	4.81	36.88	94 50	775 96
23.....	160.....	206.15	233.26	347.86	21.19	19.10	9.45	113 47	950 48
6505½		\$5,576.17	\$5,719.48	\$11,772.02	\$1,062.27	\$939.28	\$3,318.71	\$3,782.46	\$1,771 50	\$33,941 99

General average \$5.22 per acre.

A. G. CRAIG

**Cost Per Acre of Planting and First Year Care of Thousand Acre Orchard of
Lewiston-Clarkston Development Co.**

(The Square Method of Orchard Plan Used)

Plowing	\$4.00 per acre
Cultivating	None
Staking83 per acre
Planting	2.44 per acre
48 Apple Trees at 10 cents each.....	4.80 per acre
20 Peach Tees at 12 cents each.....	2.40 per acre
10 Plum or Prune Trees at 12 cents each.....	1.20 per acre
10 Pear Trees at 20 cents each.....	2.00 per acre
Fertilizer	None
Cultivation, 10 times.....	5.85 per acre
Pest Control10 per acre
Heading Trees10 per acre
Horticultural Supervision	4.00 per acre
Office or Overhead Expenses, 10 per cent.....	2.77 per acre
Total	\$30.49 per acre

W. B. LANHAM,

Horticulturist, Clarkston, Wash.

**Approximate Cost of Orchards on Ten Acre Basis, or More
Sage Brush Land**

First Year (Montana Conditions)

Cost of Clearing \$1.50 to \$3.50, Average \$2.50.....	\$25.00
Plowing, \$2.50 per acre.....	25.00
* Leveling, \$1.00	10.00
Harrowing, \$0.50	5.00
Seeding Oats and Clover:	
Oat Seed	\$.97½
Clover Seed	1.50
Planting Seed35
Irrigating	1.50
Harvesting	5.00
	} \$9.32.....
	93.20

* We think the cost of leveling in this item is not high enough for an average. We have known it to run as high as \$20 per acre.—Ed.

APPLES

381

Total expenditure for first year.....	\$158.20
Income first year	160.00
Cash Balance end of first year.....	\$ 1.80

Second Year

Irrigating Clover two times, \$2.00 per acre ..	\$20.00
Cutting Clover one time, \$0.35 per acre ..	3.50
Stacking Clover one crop, \$3.00 per acre ..	30.00
Total Expenditure	\$ 53.50

Second crop plowed under for fertilizer.	
Income Second Year, two tons hay per acre at \$5 equals \$10.....	\$100.00
Fertilizing value of Clover not included.	
Cash Balance for second year.....	\$46.50

Third Year—First Year Trees

Plowing, \$2.50 per acre.....	\$25.00
Harrowing and Smoothing, \$0.50.....	5.00
Trees (apples) 55 per acre at \$0.18 each, \$9.90.....	99.00
Marking off ground, \$0.60 per acre.....	6.00
Planting Trees and Pruning, \$0.04 each, \$2.20 per acre.....	22.00
Irrigating two times per season, \$1.50	15.00
Cultivation eleven times for season, \$3.00 each time.....	33.00
Total	\$205.00

Fourth Year—Second Year Trees

Cultivation	\$ 33.00
Irrigation	7.50
Pruning, \$1.00 per acre.....	10.00
Spraying, \$1.00 per acre.....	10.00
	\$ 60.50

Fifth Year—Third Year Trees

Cultivation	\$ 33.00
Pruning, \$1.00 per acre.....	10.00
Irrigation	7.50
Spraying, \$1.00 per acre.....	10.00
	\$ 60.50

Sixth Year—Fourth Year Trees

Cultivation	\$ 33.00
Pruning, \$1.00 per acre.....	10.00
Irrigation	7.50
Spraying, \$1.00 per acre.....	10.00
	\$ 60.50

Income ½ box per tree, 55 trees, net \$1.00 per box.....	\$275.00
Balance end of fourth tree year.....	\$214.50

Seventh Year—Fifth Year Trees

Cultivation	\$ 33.00
Pruning	10.00
Irrigation	7.50
Spraying	10.00
Thinning fruit, \$2.00 per acre.....	20.00
	\$ 80.00

Income 1 box per tree, \$1.00 net.....	\$550.00
--	----------

Balance end of 5th tree year.....	\$469.50
-----------------------------------	----------

Eighth Year—Sixth Year Trees

Cultivation, irrigation, etc.....	\$ 60.50
Thinning, \$5.00 per acre.....	50.00
	<hr/>
	\$ 110.50
Income 2 boxes per tree, \$1.00.....	\$1,100.00
	<hr/>
Balance	\$ 989.50

Summary to Eighth Year**First Year**

Expenditure	\$ 158.20
Income	160.00
	<hr/>
	\$ 1.80

Second Year

Expenditure	\$ 53.50
Income	100.00
	<hr/>
	\$ 46.50

Third Year

Expenditure	\$ 205.00
-------------------	-----------

Fourth Year

Expenditure	\$ 60.50
-------------------	----------

Fifth Year

Expenditure	\$ 60.50
-------------------	----------

Sixth Year

Expenditure	\$ 60.50
Income	275.00
	<hr/>
	\$204.50

Seventh Year

Expenditure	\$ 80.50
Income	550.00
	<hr/>
	\$469.50

Eighth Year

Expenditure	\$ 110.50
Income	1,100.00
	<hr/>
	\$989.50
Total expenditure to eighth year.....	\$ 789.20
Total income to eighth year	2,185.00
	<hr/>
Balance to end of eighth year.....	\$1,395.80

This estimate does not include cost of buildings, horses, implements, fences, etc., nor does it take into consideration any income from the land during the third, fourth and fifth years, when it is possible to get revenue from potatoes or garden truck.

R. W. FISHER,
Bozeman, Mont.

**Washington State College Estimate
Cost of Raising Apples**

Washington estimates place the cost of raising and marketing one box of apples at 53.1 cents, while a New York orchardist says his cost shows an average of \$1.10 a barrel for nine years. Aside from the value of knowing how much it costs to do business is the more interesting feature that growers are coming to demand more knowledge of what their produce costs them. No factory would think of doing business without knowing exactly what the output cost, and as a farm is nothing more or less than a factory

The various items differ widely, and here is where the long term is valuable. A thought of the greatest importance is driven home by a review of these figures. It is that profit begins after a certain point of production is reached. For instance, he says: "When our yield was 102 barrels per acre the cost per barrel was only 83 cents a barrel. When it was 35 barrels per acre the cost per barrel rose to \$1.73. In 1910 we grew a crop of 55 barrels per acre for \$1.20 per barrel." In other words, the greater the crop the less the relative cost of production, so that cost per box or barrel is of little avail unless the output per acre

Table Showing the Items of Expense in Producing Apples in a Six-Acre Orchard in Western New York

Year	Cover Crop	Spray Material	Barrels	5% Interest on Land	Equipment Charge	Overhead Charge	Labor Cost	Total Cost
1902		\$ 6.64	\$117.88	\$27.45	\$25.00	\$2.97	\$339.45	\$519.39
1903		11.22	164.92	28.98	25.00	2.88	249.55	482.56
1904		10.50	109.90	30.50	25.00	3.93	180.55	360.38
1905	\$ 6.10	12.45	88.80	30.50	25.00	3.40	158.06	324.31
1906		14.85	112.35	33.06	25.00	4.78	211.76	401.80
1907	10.00	16.85	79.80	35.56	25.00	4.89	192.30	364.40
1908		9.75	205.45	37.76	30.09	7.09	293.50	583.55
1909	8.68	19.26	196.35	41.97	38.98	5.91	280.78	591.93
1910		23.89	116.90	45.75	32.39	5.58	175.26	399.77
8-year average		\$13.94	\$132.73	\$34.61	\$27.93	\$4.60	\$231.25	\$447.57
Average per acre		2.28	21.76	5.67	4.58	.75	37.91	73.38
Average per barrel		.034	.325	.084	.068	.011	565	1.10

the farmer should know exactly what his output is costing him so that he may know whether or not he is prospering.

The New York grower communicates the results of his nine-year bookkeeping to the Rural New Yorker. He submits a table that shows he has been painstaking. His figures contain two items that do not appear in the Washington table, namely, the interest on the land, and the overhead charges, such as taxes and insurance. On the other hand his table makes no mention of bringing the orchard to bearing, as does the Washington figures. His orchard was from 36 to 50 years old and contained 234 trees, or six and one-tenth acres.

is known. The one thing lacking in this table is the output.

In 1902, for example, the cost of spray was \$6.64, while in 1910 it rose to \$23.89, with various figures between these extremes. The cost of barrels varies from \$79.80 to \$205.45, from which column we may judge to some extent of the output, though there may have been a difference in the price.

A most interesting column is that for interest on land. This has risen steadily, beginning at \$27.45 for 1902 and ending with \$45.75 for 1910. Overhead charges also show a tendency to increase. The year 1902 shows labor absorbing \$339.45, and this has been greatly reduced. The

lowest item in the labor table was in 1905, when evidently the crop was light, if one may judge by the cost of barrels. However, the year 1910 shows a labor cost of only \$175.26, when the barrels cost \$116.90, or almost as much as in 1902, when the labor cost was \$339.45. Is there not the likelihood that the orchardist scanned his cost sheet and saw that labor was costing him too much and cut it down accordingly? This is one of the most interesting and valuable features of the table. The orchardist, M. C. Burritt, concludes as follows:

"To sum up these items of cost we find that, taking the average of nine years, with an annual crop of 409 barrels, or 67 per acre, on 6.1 acres of old apple orchard, that spray material costs \$.034 per barrel; packages, \$.325; interest on land, \$.084; use of equipment, \$.068; taxes, etc., \$.011; labor, \$.565, or a total of \$1.10 per barrel. If the estimated cost of the manure, 6 cents, be added, the total will be \$1.16. This cost, of course, varies with the size of the crop. When our yield was 102 barrels per acre the cost per barrel was only 83 cents. When it was 35 barrels per acre the cost per barrel rose to \$1.73. In 1910 we grew a crop of 55 barrels per acre for \$1.20 per barrel.

"To put it in another way, we could grow and deliver on board the cars at our station a barrel of apples for from \$1 to \$1.25 with an average crop under average conditions. In doing this we would expect to make five per cent on the capital invested and to receive fair wages for our labor. In addition to this we should have all the culls and the windfall apples to sell at a clear profit, for the cost of producing and handling these has been included in the costs given above, as it could not well be separated. These have amounted to an average of 29 cents per barrel in the last nine years. To reduce the matter to a still lower basis, we think that our experience has shown that we

can expect to grow and sell a barrel of apples for 90 cents and pay all expenses connected with its production."—Spokesman Review.

Results on Eight Acres in Idaho

Statement of 1910 fruit crop from eight acres of orchard owned by B. F. Tussing, Fruitland, Idaho. Trees 13 years old.

Varieties	No. Trees	Boxes Produced	Boxes Per Tree
Jonathan	100	1,936	19.36
Rome Beauty	176	3,503	19.88
White Winter Pearmain	47	780	16.57
Mammoth Black Twig... ..	18	371	20.61
Oregon Red	12	151	12.58
Ben Davis	4	48	12.00
Delaware Red	13	135	10.38
Gravenstein	15	294	19.60
Arkansas Black	180	2,430	13.50
Totals on eight acres..	565	9,648

Grades	Number Boxes	Price Received
Extra Fancy	6,048	\$8,164.80
Fancy	2,300	2,541.00
Choice	1,300	1,050.75
Totals	9,648	\$11,756.55

Average per acre, 1,206 boxes, \$1,469.57.

Expense account to be deducted from the above as follows:

	Per Box
Harvesting	
Boxing, and making boxes.....	\$0.13
Packing05
Sorting02
Paper02
Nailing boxes, help in packing house....	.03
Hauling to cars, loading and bracing....	.02
Hauling, orchard to packing house.....	.01
Picking04
Total	\$0.32

Orchard Expenses	
Interest on investment.....	\$960.00
Pruning and hauling brush.....	160.00
Cultivating	96.00
Thinning fruit	95.00
Spraying	80.00
Irrigation	48.00
Taxes	44.00
Propping Trees	40.00
Water assessment	14.00
Repairing fences	8.00
Total	\$1,545.00

Orchard expense, per box.....	\$0.16
Harvesting expense, per box.....	.32

Total cost of production, per box..... 0.48

Gross returns, eight acres.....	\$11,756.55
Cost of production.....	4,631.04

Net balance, eight acres..... \$7,125.51

Costs in Yakima Valley

Cost per box of crop of 2,436 boxes, ten acres, part bearing, season 1912, four miles from North Yakima, Wash., five varieties; itemized. A great deal of careful bookkeeping is involved in this statement.

Total Cost, 2,436 Boxes—1912

	Pick	Haul from Orchard	Sorting	Pack	Haul Town	Boxes	Nails	Making Boxes	Paper	Waiting on Packing Tables	Total
Jonathan	\$32 00	\$ 4.00	\$56.18	\$28.90	\$ 7.23	\$60.69	\$ 2 66	\$ 5 78	\$17 28	\$ 2 00	\$216.72
	.0554	.0069	.0972	.0500	.0125	.1050	.0046	.0100	.0300	.0035	.3750
Grimes Golden.....	8 00	.63	7.63	6 15	1.54	12 92	57	1 23	3 69	42.36
	.0650	.0051	.0620	.0500	.0125	.1050	.0046	.0100	.03003444
Kentish Fill Basket...	12 25	2 50	11 88	13.25	3.21	27.83	1.22	2.65	7.95	2 50	85.24
	.0462	.0094	.0448	.0500	.0125	.1050	.0046	.0100	.0300	.0094	.3217
Baldwin.....	23.50	2.50	16.25	17.25	4.31	36 23	1.59	3 45	10.35	115.43
	.0681	.0072	.0471	.0500	.0125	.1050	.0046	.0100	.03003346
Ben Davis.	59 43	4.50	47.78	56 25	14.06	118.13	5.18	11.25	33 75	2 25	352 58
	.0528	.0040	.0425	.0500	.0125	.1050	.0046	.0100	.0300	.0020	.3134
Total.....	\$135.18	\$14 13	\$139.72	\$121.80	\$30.35	\$255.80	\$11.22	\$24 36	\$73 02	\$6.75	\$812.33
Per Box0555	.0058	0573	0500	.0125	.1050	.0046	0100	0300	.0028	.3335
Miscellaneous Expenses1625
Total cost per Box.....4960

(Spray, Thinning, Cultivating, Irrigating.)

Total Crop, (All Winter Apples)—1912

Sizes*.....	45	54	56	64	72	80	88	96	104	112	113	Total
No. Boxes	26	67	53	55	41	163	49	15	362
No. Apples.....	1,456	4,288	3,816	4,400	3,608	15,648	5,096	1,680	40,906
Sizes*.....	120	125	128	138	150	163	175	188	200	213	225	Total
No. Boxes.....	316	288	245	220	215	208	83	9	21	2,436
No. Apples.....	39,500	39,744	36,750	35,860	37,625	39,104	16,600	1,917	4,725	332,723
Average	137

*Size in terms of No. Apples per box.

V. H. HOWIE
North Yakima, Wash.

Methods of Accounting

Farm accounting, and especially cost accounting, is difficult, and requires the services of an expert bookkeeper, when the matter is carried into the smallest details. But many persons maintain a method of keeping track of their expenses

in ways which are simple yet which answer every purpose. We may not all become expert bookkeepers and, at the same time, expert fruit growers; but we should have a fair knowledge of what is the approximate cost of producing our crops. The accounts of three fruit growers are tabulated as follows:

Packing Expense in Missouri Orchards

	—Grower No.—		
	1	2	3
Box material and making.....	\$0.14	\$0.11	\$0.13
Packing07	.05	.07
Paper02	.04	.02
Nailing and packing house help.....	.03	.01	.01
Hauling to cars, loading and bracing.....	.03	.25	.01½
Hauling to packing house.....	.02	.01	.02
Picking05	.03	.03
Total	\$0.36	\$0.50	\$0.29½

Orchard Expense

Interest	\$160.00	\$40.00	\$160.00
Pruning and hauling brush	22.50	3.50	6.00
Cultivating	30.50	3.90	.
Thinning	2.00	.
Spraying	10.00	3.70	10.00
Irrigating	10.00	5.00
Taxes	10.00	1.53	10.00
Propping	5.00
Water assessment	1.50	1.50
Repairing fences	1.00
Fertilizer	40.00
Irrigation flumes and ditches.....	10.00
Spraying chemicals	1.75
Total	\$300.00	\$54.63	\$202.50
Total number of boxes harvested.....	600	300	600
Orchard expense, box.....	\$0.50	\$0.17	\$0.33
Packing expense36	.50	.29½
Total cost, per bushel	\$0.86	\$0.67	\$0.62½

In connection with the method of keeping track of the cost of producing a crop of apples, Peter Hovland, Wenatchee, Wash., sends us an outline of the system which he follows, and says that it "will show the correct expenses and tell the grower about the leaks in his business, if there are any." Mr. Hovland's system is as follows:

"Bearing Orchard.—First, take an estimate of all of the property for what it can be sold for at present. Never mind what you paid for it, or what you want for it. Put upon it the price that it is worth today, then add the interest of this valuation to the producing and marketing expenses and divide them by the number of boxes harvested."

Value of land:

Irrigated, with pipe lines, flumes, ditches.....\$
Unirrigated

Value of buildings.....

Total

Productive expenses:

1. Interest on valuation of property.
2. Water rent.
3. Taxes.
4. Pruning.
5. Brush hauling.
6. Plowing, harrowing and cultivating.
7. Grubbing weeds.

8. Fertilizers.
 - Barn-yard manure.
 - Commercial fertilizers.
 - Cover crops.
9. Spraying.
10. Irrigating.
11. Propping.
12. Thinning fruit.
13. Repair on pipe lines, flumes, ditches.
14. Repair on fences.
15. Repair of implements, harness, etc.
16. Loss of trees and planting new ones.
17. Grafting and budding.
18. Hay and grain for horses, and care.
19. Insurance on buildings, horses and implements.
20. Unexpected expenses.

Marketing expenses.

1. Picking.
2. Orchard Hauling.
3. Packing
4. Boxes, nails and making.
5. Paper.
6. Nails.
7. Hauling.
8. Help in packing house.
9. Unexpected expenses.

In this outline, as suggested by Mr. Hovland, there are some important items which are not considered, such as the depreciation on the horses, tools, wagons, spraying machines, etc., neither is there any selling expense, as the grower perhaps sold his fruit direct and therefore did not have to allow a commission to the association or broker. No charge is made for grading the fruit, as that is possibly included in the packing charge. No account is taken of the cost of loading and bracing the boxed fruit in the cars, although there is such a charge made by most growers.

One thing included in the above list of items that does not seem to us like a direct charge on producing a crop is that of fertilizers. As a rule, the influence of any application of fertilizers, whether in the form of manure or cover crop, is felt over a period of years, and under such conditions it really becomes one of the assets and becomes chargeable each year under the head of depreciation. In that case the annual charge for fertilizers becomes less.

We hope our readers will consider these figures as given above, and will discuss

the plan as suggested by Mr. Hovland. A cost system is not the product of one man, and neither is it the outcome of one year, but it is the result of the combined efforts of a great many minds working for a period of years on the same problem. It has taken a score of years for the printers to work out a cost system that is simple and accurate, but as it now is the matter of obtaining the cost of printing any job is comparatively simply and easily arrived at. In the cost of producing apples, there is an almost innumerable list of things which have to be taken into consideration, but by comparing a number of different plans and discussing them freely, an outline can be worked out that will be simple and serviceable to all.

THE FRUIT-GROWER,
St. Joseph, Mo.

Cost of Spraying

In our effort to find a unit of cost for the various kinds of labor performed in the orchard, and in the marketing of fruits, we give herewith an estimate made by E. A. Burnett, director of the Nebraska Experiment station. It must be noted that the cost in Nebraska may not be

exactly the same as the cost in some other states where the labor is more or less than in Nebraska, or where the raw materials may be more or less, but this will assist in reaching a conclusion as to what would be the probable cost.

Number of orchards sprayed.....	16
Total number of trees sprayed.....	3,300
Average age of trees.....	18 years
Average number of sprayings per year.....	4
Average quantity of spray per tree each year.....	13 gallons
Average quantity of spray per acre (50 trees).....	650 "
Average cost of spray material per 100 gallons.....	\$0.87
Average cost of applying spray per 100 gallons.....	\$0.98
Average total cost of spraying per 100 gallons.....	\$1.85
Average annual cost of spray material per tree.....	11.3 cents
Average annual cost of applying spray per tree.....	12.7 "
Average total annual cost of spraying per tree.....	24.0 "
Average total annual cost of spraying per acre (50 trees).....	\$12.00

Results of Spraying

Average annual yield and value per acre (estimated on basis of 50 trees)—

Sprayed Trees

Marketable fruit	220 bu.	\$114.40
Culls and windfalls.....	55 bu.	3.30
	<hr/>	<hr/>
	275 bu.	\$117.70

Unsprayed Trees

Marketable fruit	90 bu.	\$36.90
Culls and windfalls	85 bu.	4.25
	<hr/>	<hr/>
	175 bu.	\$41.15

Summary

Difference between sprayed and unsprayed trees.....	\$76.55
Average cost of spraying	12.00
	<hr/>
Average net gain per acre (50 trees) from spraying.....	\$64.55

APPLE ORCHARD PROFITS

R. R. SLOAN

Huron County, Ontario

In a ten-acre orchard, the acre cost and expenditure for four years are given below. Ten acres usually contain about 400 trees, or 40 trees to the acre, but as some of my trees are grafted and did not bear at the same time as the others, I will include only 350 trees.

The first year we had 700 barrels of apples from these 350 trees, and they were sold at \$1.65 a barrel on the ground, or \$132 an acre. The varieties consisted of Ben Davis, Baldwin, Greening, Spy and King. In the following year, the crop was much lighter, only 250 barrels from the same area, at \$1.50 a barrel, or \$45 an acre. In the third year we harvested 750 barrels at \$2.25 a barrel, or \$192.80

an acre. Last year the apple crop in Huron county was almost a complete failure. Nevertheless, we harvested nearly 100 barrels off these 350 acres, at \$3.75 to \$4 a barrel, or \$43 an acre, giving a total of \$413.40 or \$103.35 as the average for four years off trees from 17 to 20 years of age.

Now, let us look at the cost of production and maintenance. It cost \$2.35 an acre for plowing, \$1.05 an acre for cultivating three times, \$3.75 an acre for pruning, \$8 to \$9 for three sprayings with Bordeaux mixture. Last year we used lime-sulphur, which cost a little more, for the first spraying, and arsenate of lead along with it, fertilizing at the rate of \$2.50 an acre up to \$3 for manure and ashes. It is sometimes difficult to get ashes, but we get a great deal of manure at 50 cents a load and draw it ourselves.

Of course, the benefit of fertilizing is spread over a number of years.

The cost of pulling at ten cents a barrel would be practically \$9 an acre. That makes a total of \$27.60 as the total cost an acre, without counting anything for cover crops. We generally grow clover for its manure value, and if we don't we always have sufficient snow. This deducted from \$103.35, the average for four years,

leaves a balance of \$76.35 an acre, or \$763.50 for ten acres.

We have some sections of older orchards which, of course, give much better results. I will not go into details, but give one example of what we have done on several occasions. One plantation, 60 years of age, consisting of 35 Spy trees, has run as high as \$18 a tree, and even at the low price of \$1.50 a barrel has yielded \$530 an acre.

Orchard of Mr. M. C. Burritt, Monroe Co., N. Y.

Field A—1907—Fifth Year

216 apples, 40 pears, 211 plums. Total, 467 trees; 6.6 acres.

Operation	Total Hours		Total Cost	Hours per Acre		Cost per Acre	Cost per 100
	Man	Horse		Man	Horse		
Mulching.....	3	6	\$ 1.05	.455	.91	\$0.16	\$0.22
Pruning.....	11	1.65	1.6725	.35
Cultivating, 1.....	7	7	1.75	1.06	1.06	.26	.38
Cultivating, 2.....	10	10	2.50	1.51	1.51	.38	.54
Cultivating, 3.....	6	6	1.50	.91	.91	.23	.32
Plowing in fall.....	47	94	16.45	7.12	14.25	2.50	3.52
Banking trees.....	12	1.80	1.8227	.39
Harrowing.....	21	42	7.35	3.18	6.36	1.11	1.58
Total labor cost....	117	165	\$34.05	17.73	25.00	\$5.16	\$7.30
Four loads manure at \$1.50.....			\$ 6.00			\$0.91	\$1.29
Equipment charge.....			1.15			.174	.25
Taxes.....			5.29			.801	1.13
Interest.....			38.48			5.83	8.23
Total cost.....			\$84.97			\$12.875	\$18.20

Income, Cost and Profit on Beans, Field A—1907

	Income	Cost	Profit
75 bushels at \$1.50.....	\$112.50
3½ tons pods at \$6.00.....	21.00
	\$133.50	\$94.65	\$38.85

Loss on Field, 1907

	Total	Per Acre
Net income from Beans.....	\$38.85	\$ 5.89
Cost of Orchard.....	84.97	12.87
Loss.....	\$46.12	\$6.98

"A summary of the cost of the orchard, the net income from the crop, the income from the orchard, and the profit and loss by years for the eight years brings us to the meat of the whole matter."

Summary of Costs for Eight Years—Field A—6.6 Acres

Year	Crop Grown	Net Income from Crop	Income from Orchard	Orchard Cost of	Profit	
1903	Corn.....	\$ 15.17	\$109.87	\$ 94.70
1904	Beans.....	42.57	216.16	173.59
1905	Beans.....	43.13	83.78	40.65
1906	Beans.....	120.90	80.14	\$40.76
1907	Beans.....	38.85	84.97	46.12
1908	Corn.....	37.68	64.22	26.54
1909	Oats and Strawberries.....	100.61	\$27.88	84.73	43.76
1910	Wheat.....	60 70	38.65	96.35	3.00
*		\$459.61	\$66.53	\$820.22	\$87.52	\$381.60

Net loss on field for eight years..... \$294.08

Average annual loss..... \$38.76

Total cost per acre, exclusive of income.....	\$124.27
Total cost per acre, including income.....	44.55
Total net cost per 100 trees.....	62.97
Total net cost per apple tree.....	1.37
Total net cost per apple tree, exclusive of income.....	3.80
Total labor cost per acre.....	35.09
Total cash cost per acre.....	89.19

* No allowance is made for what could have been raised on the land if no trees had occupied it. This amounted on the average to \$4.00 per acre year, which should be added to cost.—Ed.

Summary of the Cost of a Four-Year-Old Apple and Peach Orchard—Same as Above

Year	Crop Grown	Net Income from Crop	Income from Orchard	Cost of Orchard	Profit	Loss
1908	Beans.....	\$63.37	\$130.12	\$62.75
1909	Beans.....	66.70	85.03	18.33
1910	Beans.....	79.81	83.39	3.58
1911	Beans.....	53.20	\$46.05	61.95	\$37.30
		\$267.08	\$46.05	\$360.49	\$37.30	\$84.66

Total cost per acre, exclusive of income.....	\$72.10
Total cost per acre, including income.....	9.47
Total net cost per apple tree.....	3.76
Total net cost per apple tree, excluding income.....	2.85

From Ithaca, New York

Income Per Acre.—The information gathered on this point is displayed in two tables. One shows the average gross income per acre for each of the five years. The general average for the five-year period is \$109.20 per acre. This is \$16 less per acre than was found for Orleans county. The second classification shows how these incomes are distributed with reference to the number of orchards and number of acres under each group. The grower will find it interesting to study

these tables with reference to his own orchard.

Average Gross Income Per Acre

1902	\$112.00
1903	129.00
1904	98.00
1905	103.00
1906	104.00

General average for the five-year period \$109.20

M. B. CUMMINGS,
Ithaca, N. Y.

TWO FIVE HUNDRED ACRE ORCHARDS IN WESTERN MICHIGAN

The figures in the left hand column are based on returns from actual orchards in first-class location, with good soil, and that have had expert care from the beginning.

The figures in the right hand column are based on ordinary location, average soil, and on the ordinary or average care given many Michigan orchards today.

Original Investment

500 acres land (cleared).....	\$ 21,000.00	\$ 14,000.00
Ten teams, utensils, harness, tools, etc.....	6,500.00	3,750.00
Packing sheds to be built when orchard starts bearing.....	2,000.00
Sheds and fences	1,750.00	750.00
Trees and plantings of same.....	8,250.00	5,000.00
Total investment	\$ 39,500.00	\$ 23,500.00
First four years' operation—1st period—income per year on potatoes, beans and clover, alternating, average	\$ 8,500.00	\$ 1,400.00

Expenditures Per Year

Work on orchard, including clover plantings on best orchard, \$4.50	\$ 5,300.00	\$ 1,610.00
Taxes and insurance, depreciation, repairs, etc.....	1,250.00	650.00
Overseeing and incidentals.....	1,500.00	750.00
Total expenditures per year.....	\$ 8,050.00	\$ 3,010.00
Net income per year.....	450.00	*1,610.00
Net income four years	1,800.00	*6,440.00
Value of orchard end four years.....	62,500.00	30,000.00
Total assets	64,300.00	23,560.00
Less original investment.....	39,500.00	23,500.00
Net profit four years.....	\$ 24,800.00	\$ 60.00
Net profit per year.....	6,200.00	15.00
Interest on investment per year.....	16%	1-15 of 1%

Next Three Years' Operations

Second period—fifth to seventh year.

Income Per Year

1 case cherries per tree, \$1.25 each per case.....	\$ 25,937.50	\$
½ case cherries per tree, 75c each per case.....	7,781.25
1 bushel peaches per tree, \$1.00 per bushel.....	20,750.00
½ bushel peaches per tree, 60c per bushel.....	6,225.00
Total income per year.....	\$ 46,687.50	\$ 14,006.25

Expenditures Per Year

Work on orchard (including clover on best orchard).....	\$ 6,000.00	\$ 1,610.00
Taxes and insurance, depreciation, repairs, etc.....	1,250.00	650.00
Overseeing and incidentals.....	2,250.00	750.00
<hr/>		
Total expenditures per year.....	\$ 9,500.00	\$ 3,010.00
Net income three-year term.....	\$112,561.00	\$ 26,548.75
Net income first four-year term.....	1,800.00	6,440.00
<hr/>		
Total net income seven years.....	\$114,361.00	\$ 50,000.00
<hr/>		
Value of orchard end seven years.....	\$125,000.00	\$ 50,000.00
<hr/>		
Total assets end seven years.....	\$239,361.00	\$ 76,548.75
Less original investment.....	39,500.00	23,500.00
<hr/>		
Total net profits for seven years.....	\$199,861.00	\$ 53,048.75
Average net profit per year.....	28,551.57	7,578.40
Percentage profit on investment.....	71%	32%

Next Three Years' Operations

Third period—eighth to tenth years inclusive.

Income Per Year

Cherries 1½ cases per tree \$1.25.....	\$ 38,906.25	
Peaches 1½ bushel per tree \$1.00.....	31,125.00	
Apples ½ bushel per tree \$0.90.....	6,075.00	
Cherries ½ case per tree \$0.75.....		\$ 7,781.25
Peaches ½ bushel per tree \$0.60.....		6,225.00
<hr/>		
Total income per year.....	\$ 76,106.25	\$14,006.25

Expenditures Per Year

Work on orchard (includes clover on best orchard).....	\$ 6,300.00	\$ 2,610.00
Taxes, insurance, depreciation, repairs, etc.....	1,250.00	650.00
Overseeing and incidentals.....	3,000.00	1,000.00
<hr/>		
Total expenditures per year.....	\$ 10,550.00	\$ 4,260.00
Net income per year.....	65,556.25	9,746.25
Net income three years.....	196,668.84	29,238.75
Net income first seven years.....	114,361.00	26,548.75
Value of orchard end of ten years.....	200,000.00	60,000.00
Total assets end ten years.....	511,029.84	115,787.50
Less original investment.....	39,500.00	23,500.00
Total net profit in ten years.....	471,529.84	92,287.50
Average net profit per year.....	47,162.98	9,228.75
Interest on investment per year.....	122%	39%

Next Three Years' Operations

Fourth period—eleventh to thirteenth years inclusive.

Income Per Year

Cherries 3 cases per tree \$1.25 per case.....	\$ 77,812.50	
Peaches 1½ bushels per tree \$1.00 per bushel.....	31,125.00	
Apples 3 bushels per tree \$0.90 per bushel.....	36,450.00	
Cherries ½ case per tree \$0.75 per case.....		\$ 7,781.25
Peaches ½ bushel per tree \$0.60 per bushel.....		6,225.00
Apples ½ bushel per tree \$0.40 per bushel.....		2,700.00
<hr/>		
Total income per year.....	\$145,387.50	\$16,706.35

Expenditures Per Year—Same Years

Work on orchards (includes clover on best orchards)....	\$ 7,000.00	\$ 3,000.00
Taxes, depreciation, repairs, etc.....	1,250.00	650.00
Overseeing and incidentals.....	3,500.00	1,250.00
	<hr/>	<hr/>
Total expenditures per year	\$ 11,750.00	\$ 4,900.00
Net income per year	133,637.50	11,806.25
Net income three years.....	401,012.50	35,418.75
Net income first ten years.....	311,029.84	55,787.50
Value of orchard end fourth term	300,000.00	70,000.00
	<hr/>	<hr/>
Total assets fourth term	\$1,012,042.34	\$161,206.25
Less original investment.....	39,500.00	23,500.00
	<hr/>	<hr/>
Total net profit 13 years.....	\$972,542.34	\$137,706.25
Average net profit per year	74,810.90	10,593.00
Interest on investment per year	195%	45%

BEN NEWHALL
North Manitou Island, Mich.

Cost and Result of Fertilization

This is the touchstone to which everything must yield, and we claim the system advocated will give infinitely better results than any other known. It is a system that demands just the material required to make fruit, and in as exact proportion as science can indicate. Under this system each tree may be regarded in the light of a factory, changing well selected raw material into the finished product. Nothing can be more reasonable, nothing more simple. To produce the results given below, the retail cost of fertilizer has only been from \$8.00 to \$9.00 per acre, or about eight cents per barrel. My average has been 110 barrels for ten consecutive years, omitting the present year. This means 1,100 barrels from every acre of orchard in the time named of good packed fruit. This completes my experiments along the line of low fertilization, and the results are gladly given to my brother orchardists. Now the question arises, How much has been lost by following so closely a system that furnishes material, seemingly, inadequate to the needs of a heavy crop? How much more of the same fertilizers could have been profitably used? Would 50 per cent or 100 per cent more have increased the crop proportionally? These are live questions to the man whose interests lie largely in apple trees, and are questions which the writer now turns to

with full purpose of making a satisfactory solution.

Results of Fertilization

Below is an account kept with the only four acres of orchard in full bearing at the time it was made. It is a fair index of many other like crops, and in no way misleading, as many others, with the same treatment, have done even better.

Pruning	\$ 10.00
Fertilizer, 4 acres at \$9..	36.00
Sowing fertilizer	2.00
Discing and harrowing	8.00
Seed for cover crop.....	5.70
Sowing cover crop	1.50
Spraying three times.....	22.40
Barrels, 451 at 25c.....	113.00
Picking, packing and truckage, at 25c	113.00
Sundry expenses	8.40
	<hr/>
	\$ 320.00
451 barrels apples, net proceeds..	1,017.74
	<hr/>
Net returns	\$ 697.74

This is but a fraction short of \$175, net, per acre, or 17½ per cent for the owner on a valuation of \$1,000 *per acre*. This seems better than bank stock yielding 4½ per cent, or even gold mines in the West, which promise wealth quickly, but usually wind up with loss of expected dividend, and investment as well. The statement of 17½ per cent returns is not given as something wonderful or phenomenal. On the contrary, it is sent forth with the full knowledge that even better

results have been obtained by many persons known to the writer, who have fertilized with the sole view of heavy crops, rather than of demonstrating a rule which could be worked out by anyone along scientific lines. It shows what is possible to all who intelligently apply themselves to pleasant, healthful orchard work in the beautiful Annapolis valley of Nova Scotia.

What a Small Orchard Can Do

The following is a record of a small orchard on the property of Judge Chipman, Kentville, N. S.

This orchard was planted in 1883. It originally contained 22 trees of the Blenheim Orange variety, and covered an area of two-thirds of an acre. Root crops were grown in the orchard for the first 10 or 11 years. Thereafter it was given clean cultivation with the plow and harrow. Stable manure was largely used during the early years of the orchard's life, then commercial fertilizers in the form of bone meal and muriate of potash. During the last eight or nine years the fertilizers applied have been acid phosphate, muriate of potash and nitrate of soda, the latter in small quantities.

Product of 22 Blenheim Orange apple trees from 1892 to 1898, inclusive. Tree run:

				---Barrels---
In 1892 at 9 years of age....			22	
1894 " 11 "			50	
1896 " 13 "			80	
1898 " 15 "			90	
				242
One tree not producing after 1898.				

Product of 21 trees from the year 1898:

				---Barrels---
In 1900 at 17 years of age....			130	
1902 " 19 "			160	
1904 " 21 "			140	
1905 " 22 "			60	
1906 " 23 "			130	
1907 " 24 "			15	
1908 " 25 "			90	
1909 " 26 "			183	
1910 " 27 "			4½	
				912½
				1,154½

During the past 11 years the yield from this orchard has averaged about 83 barrels per year, or at the rate of nearly 125 barrels per acre. At \$2 per barrel, tree run, this means a yearly return of \$250 per acre.

What One Apple Tree Has Done

JOSEPH A. KINSMAN

Lakeville, Kings County, Nova Scotia

On the farm of Joseph A. Kinsman, in Lakeville, Kings county, stands the champion apple tree of Eastern America. A letter written by Mr. Kinsman on April 15, 1899, contains interesting information about this tree. Mr. Kinsman, under that date, wrote:

"It is a pleasure for me to give particulars about the remarkable Gravenstein apple tree of which I have been the owner since 1878. This tree is situated on my farm, at the base of the North mountain, in Lakeville. It grows on the side of the bank of a ravine that makes down from the mountain, in which a small stream of water runs, the roots of the tree running into this stream. The trunk of the tree is nearly three feet in diameter. The limbs begin to branch out about six feet from the ground; the branches have a spread of over 80 feet. The tree is now 100 years old. It was grafted to Gravenstein some 30 years ago. I have about 25 acres of orchard, but I have no tree more thrifty than this one. It only bears on alternate years, as a rule. On some off years it might have four or five barrels of apples. It is not cultivated in any way, Nature having provided everything that is wanted for this tree. I have kept a record of the apples it has borne since I owned it, which is as follows:

In 1878 it produced 15 bbls. merchantable fruit			
1880 " 18 "			
1882 " 21 "			
1884 " 20 "			
1886 " 21 "			
1888 " 23 "			
1890 " 20 "			
1892 " 21 "			
1894 " 26 "			
1896 " 27 "			
1898 " 22 "			
Total.....	234	" at \$2 per bbl...	\$468

I have made no account of the apples that dropped during those seasons, nor have I of the loss in picking, which is very great, owing to the top being nearly 50 feet high on one side, on account of its position on the side of the bank. In 1896 I should have had over 30 barrels, if it had not been for an accident in the

breaking of a large limb from the top, in August. The apples have averaged me \$2 per barrel."

G. C. MILLER,
Middleton, N. S.

POINTS ON PACKING AND HANDLING APPLES IN BARRELS

G. H. VROOM
Dominion Fruit Inspector
Middleton, Nova Scotia

In compliance with your request to write something touching the apple industry in the Province of Nova Scotia, I beg to submit the following:

First, and very important in packing and marketing fruit, is a good, well made package. The staves in a barrel should be so made that when the barrel is finished it will be 18½ inches in the bilge, inside measurement. These staves should be thoroughly dried before using or making up into barrels. Spruce is the best wood for apple barrels, on account of it being light to handle, and more durable than other kinds of soft wood. Both ends of an apple barrel should be planed, and should be made of spruce wood, five-eighths of an inch thick, and cut large enough to give a 17-inch inside measurement to the head, when the barrel is finished. Hoops may be either flat or half round. A split half-round hoop made of birch or any other tough, hard wood, will stand more handling than a flat one, but does not give the barrel so good a finish. I think it would be a great advantage if eight hoops were put on a barrel instead of six. All barrels used for packing apples should be thoroughly and properly nailed before the fruit is packed in them, except the bottom, which should be well nailed after the barrel has been closed up. Care should be taken that the nails enter the head, and not go under it, as is very often the case, and if the barrel gets a fall, or the pressure is heavy on any particular barrel when in the sling, while being lowered into the ship's hold, the head comes out, and the apples go down among the barrels and are wasted. Too much care cannot be used in nailing the barrel. The proper way is to use small nails and liners, the same as used in flour barrels.

One other important thing is the stenciling. There are still left a few people who persist in marking their barrels with pencil, and in some cases incompletely at that, and the package looks badly, or, to say the least, has an unfinished appearance.

The Inspection and Sale Act reads as follows: "Every person who, by himself or through the agency of another person, packs fruit in a closed package, intended for sale, should cause the package to be marked in a plain and indelible manner in letters not less than half an inch in length, before it is taken from the premises where it is packed, with the initials of his Christian names and his full surname or, in the case of a firm or corporation, with the firm or corporate name and address, with the name of the variety or varieties, and with a designation of the grade of fruit, which shall include one of the following four marks, viz.: Fancy, No. 1, No. 2, No. 3. Such mark may be accompanied by any other designation of grade or brand, if that designation of grade or brand is not inconsistent with or marked more conspicuously than the one of said four marks which is used on the said package."

Every fruit grower should have a set of stencils, so that he will be in a position to properly mark his barrels, for by so doing he will add to the price in the market, and consequently to his bank account.

More care than is generally taken should be exercised in handling from orchard to storehouse. A great many growers fill their barrels in the orchard, and allow them to sit about on the ground without the heads in and, if rain happens to fall, the apples, as well as the barrels, are soaked with water. And again, what is nearly as bad, is to head the barrels and lay them down on the side, scattered over the orchard on the cultivated land, and the rain spatters mud over them, and by the time the packages are stored they look anything but attractive, and bring less money on the market because they show unmistakable signs of carelessness and bad handling.

Another mistake that is being constantly made by growers and shippers is in putting too many barrels in one car. In many cases they are piled five tiers high, and if the car happens to be opened on the opposite side from which it was loaded at the fruithouse, it is very difficult to get the top barrels out without injuring them, and after the barrels in the center of the car have been removed very many of them get badly bumped while being taken down during the unloading process, notwithstanding the care taken by the men who handle them from car to ship. The barrels are rolled out on the shed floor, and are taken in slings and lowered into the ship, six at a time, and stowed five tiers high.

Speaking generally, I would say there is room for improvement in a great many ways in the handling of the apple crop

in Nova Scotia from the time the fruit is fullgrown on the tree until it finds its way into the markets of the world, and this applies to local as well as export trade. In the first place, more care should be exercised in the picking, so that the fruit is not bruised by being thrown into the basket, and then dumped carelessly from the basket into the barrels. This also applies to the re-packing in the fruit houses. Apples should always be handled in such a manner that they will not be bruised. This can be done, and will be done when growers realize that when they are handling apples roughly they are simply throwing money away. When a barrel of nicely handled fruit, free from bruises, will sell for \$3 on a good market, a barrel of badly handled, bruised fruit will only sell for \$2, even if the fruit in both barrels were taken from the same tree.

Cost of Hauling to Market

Table No. 1.—Average cost of hauling products from farms to shipping points: Totals for States represented.

Product Hauled	Number of Counties reporting	Average					
		Miles to shipping point	Days for round trip	Pounds in one load	Cost per load	Cost per 100 pounds	Cost per ton per mile
Apples.....	114	9.6	.9	2,300	\$2.79	\$0.12	\$0.25
Barley.....	226	8.8	.7	3,970	2.67	.07	.16
Beans.....	22	9.0	.8	3,172	2.75	.09	.20
Buckwheat.....	8	8.2	.8	2,438	2.90	.11	.27
Corn.....	981	7.4	.6	2,696	1.78	.07	.19
Cotton.....	555	11.8	1.0	1,702	2.76	.16	.27
Cottonseed.....	110	10.7	.9	1,654	2.42	.15	.28
Flaxseed.....	51	10.4	.7	3,409	2.70	.08	.15
Fruit (other than Apples).....	99	11.6	1.1	2,181	3.53	.16	.28
Hay.....	761	8.3	.7	2,786	2.32	.08	.19
Hemp a.....	7	5.2	.7	3,393	2.10	.06	.23
Hogs (live).....	316	7.9	.7	b1,941	2.00	b .10	b .25
Hops.....	14	11.7	1.0	3,665	3.89	.11	.19
Oats.....	798	7.3	.6	2,772	1.82	.07	.19
Peanuts.....	19	8.1	.6	1,363	1.67	.12	.30
Potatoes.....	569	8.2	.7	2,679	2.34	.09	.22
Rice.....	18	7.5	.8	2,407	2.70	.11	.29
Rye.....	78	8.4	.7	2,625	2.23	.08	.19
Timothyseed c.....	5	8.0	.8	2,410	1.92	.08	.20
Tobacco.....	113	9.8	.8	2,248	2.28	.10	.20
Vegetables (other than Potatoes).....	152	9.8	.9	1,852	2.84	.15	.31
Wheat.....	1,051	9.4	.8	3,323	2.86	.09	.19
Wool.....	41	39.8	5.6	4,869	21.39	.44	.22

a Kentucky only. b Average for six States only. c Iowa only.

Apples

Apples were reported as a surplus crop so generally by the correspondents in this investigation that a fairly good basis is afforded for finding average conditions of hauling this fruit from farms in the United States. Owing to the small number of returns from some states, the averages for the geographic divisions and for the United States in Table 2 should be used in comparison when the figures for a single state are considered.

The high cost per 100 pounds for haul-

ing apples from farms in the South Central Division is due largely to the small loads taken, and in the Western Division the long time for the average round trip makes the cost per 100 pounds twice the average for the North and South Atlantic and North Central Divisions.

It is to be noted in connection with this product that it is the practice in some sections for the farmers to sell their apples on the trees, the buyer to do all the picking and hauling. This, however, does not invalidate the figures as given in Table 2.

Table No. 2—Average Cost of Hauling Apples from Farms to Shipping Points

	Number of Counties reported	Average				
		Miles to shipping point	Days for round trip	Pounds in one load	Cost per load	Cost per 100 pounds
Maine.....	5	8.8	1.3	2,180	\$4.74	\$0.22
New Hampshire..	5	6.2	.5	2,630	2.02	.08
Vermont.....	1	7.1	.7	3,000	2.62	.09
Massachusetts ..	2	9.2	.6	3,250	2.63	.08
Connecticut.....	1	10.6	.7	2,000	2.80	.14
New York.....	15	7.4	.6	2,523	2.15	.09
New Jersey ..	3	7.1	.7	2,667	2.51	.09
Pennsylvania ..	8	8.2	.8	2,362	2.73	.12
Virginia.....	7	10.9	1.0	2,750	2.88	.10
West Virginia.....	11	10.0	1.1	2,332	4.00	.17
Ohio.....	5	7.0	.7	2,170	2.14	.10
Indiana.....	3	9.7	1.2	2,283	4.20	.18
Illinois.....	6	5.8	.5	2,367	1.25	.05
Michigan.....	4	9.1	.7	2,538	2.06	.08
Missouri.....	13	10.5	1.0	2,108	2.56	.12
Kentucky.....	4	11.6	.8	1,600	2.20	.14
Tennessee.....	8	11.2	1.0	1,556	2.62	.17
Arkansas.....	6	19.2	2.0	1,700	4.76	.28
Oregon.....	3	11.8	1.9	2,583	6.02	.23
California.....	4	15.6	1.7	4,500	10.40	.23
Geographic Divisions:						
North Atlantic.....	40	7.9	.7	2,490	2.53	.10
South Atlantic.....	18	10.5	1.0	2,584	3.18	.12
North Central.....	31	8.5	.8	2,267	2.26	.10
South Central.....	18	13.8	1.2	1,617	3.11	.19
Western.....	7	13.7	1.8	3,558	8.36	.23
States Represented.....	114	9.6	.9	2,300	2.79	.12

FRANK ANDREWS

HORTICULTURAL EXPERIENCE TABLE

Standards of Efficiency in Labor, in Machinery, in Management, Labor, Cost and Money Cost per Unit of Work

Kind of Work	Con- ditions	Method	Number of Men and Horses	Wages	Amount of Work Done	Time Required (in hours)	Mater- ials	Items of Cost	Cost per Unit of Work Done	Work Done per hour per man	Reported by
Spraying 3-yr old Peach trees	Weather windy	Power Sprayer (Hardie) hired by the day	2 men 1 boy 1 team	\$2.50 ea \$5.00	350 trees 2½ acres	6 hours	— gals. 1:10 Rex Spray	labor Spray	per gal. per tree per barrel		
First picking of Peaches.. .	Fruit much scattered 3-year old trees		1 man	\$2 50 a day	18 boxes	5 hours		Labor \$1.25	\$0.07 per box	6 boxes	S F Smyzer Wapato Wash.
Clearing land..											
Leveling land (ex- treme and ordi- nary cases)...											
Putting Water on land... .		by gasoline pump by electric plant, etc.									
Flume building.											
Blasting hardpan.											
Planting											
Irrigating.											
Cultivating											
Picking.											
Packing.											
Box making											
Storing..											
Shipping											
Selling, etc.											

(Arrangement suggested by Prof. S. F. Smyzer, North Yakima, Wash., covering the various items of orchard cost.)

SOME POINTS IN ORCHARD MANAGEMENT

Adapted to North Central Washington Organization of the Company Orchard Work

The consulting horticulturist, who has charge of the orchard work makes trips to the orchards every few weeks and, with the other officers of the company, outlines the work in advance. The consulting horticulturist stays with the heads of departments and men until he is

sure that all details of the work will be carried out properly.

Next in line is the superintendent or foreman. This office is filled by a man well up in horticulture and who also has executive ability. Under the superintendent is the head treeman, who has as many assistants as the size of the orchard company requires. The irrigation department is headed by a man especially trained in this line. He advises with the irrigators, measures the water and sees that each type of soil is properly irri-

gated Each orchard laborer has a special tract on which he stays during the season, and is held responsible for the labor on that tract.

On his trips the consulting horticulturist gives evening lectures to all the men; the effort is to train them, to inspire them in the work and develop greater individual interest among them

Planning the Orchard

When the company decides to make a new planting, the soil is first selected and examined very carefully Both the surface soil and subsoil are examined. Orchardists often overlook the subsoil examination but it is very important The tree does a great deal of work below the surface and to get the best results must have a congenial subsoil

The best commercial varieties are then selected which are best suited to the altitude, soil and other conditions. The varieties are always arranged so as to secure cross-pollinization. Honey bees being the chief agents of cross-pollination, are kept in the orchard as soon as the orchard comes into bearing.

The orchards are usually planted 30 feet on the square with a tree in the center of the square It will be seen that the trees in the centers of the squares make also an orchard 30 feet on the square. In other words, we have a double orchard each with its cross-pollination varieties. All the trees stand for 11 or 12 years, and then the orchard of least value is cut out. If we plant a variety that is somewhat untried, we always double it with a thoroughly proven variety. The reason is evident: if the questionable variety does not prove better than the proven variety it can be grubbed out at the end of 11 or 12 years, and the permanent orchard not injured in the least This is a good way to handle questionable but promising varieties, such as the Delicious and Stayman Winesap.

This system of planting permits the renewal of orchards, a very important consideration for the orchardists of the arid West. If it proves true, as many predict, that most of our orchards will

have passed the best bearing period at the age of 35 or 40 years, it behooves us to plan our orchards so that they can be renewed at about that time if necessary. By this system of planting, young trees can be replanted in the centers of the squares when the orchard is 25 or 30 years old and, when the young trees come into bearing, the old ones can be cut out. Our aim is to make the orcharding *permanent*, and to this end we safeguard ourselves in every possible way.

Planting Two-Year-Old Trees

Whether to plant one or two-year-old trees is a question on which there is a difference of opinion. I will set down my results and let the reader judge for himself. During the last two years we have planted over 80,000 two-year-old trees, we have averaged about a 95 per cent stand, and the trees at the end of the second year average better than the one-year-old trees that have been three years in the orchard. We have saved a year by planting the two-year-old stock. We get better heads when planting the two-year-olds. It is hard for a one-year-old tree, when planted in the orchard, to make its root connection with the soil and put out a good head the first year. They usually put out a weak head with poor crotches. If the tree is allowed to stand in the nursery another year, where it has its root connections with the soil, it puts out a good head with strong crotches and leaders with the proper angle (about 45 degrees) from the trunk of the tree. If the tree does not have a good head do not plant it. This insures good heads on the trees, a very important point, because the whole tree structure is built on the head, and more trees break down because of weak heads than from any other cause.

However, it is harder to grow the two-year-old trees than the one-year-old trees. If you are not going to give the two-year-old trees the special care they require I would advise you not to plant them.

Pruning Young Trees

The main thing here is to develop a permanent tree structure. If the tree is a one-year-old and puts out a poor head, re-

head it. Have never less than four or more than six leaders. Have the leaders spaced up and down on the trunk so as not to form bad crotches. Have the leaders spaced around the tree so that no leader is directly under another, but let each have a position of its own, so that when you look directly down on the tree the leaders look like the spokes of a wheel. When the leaders have grown to be about five and a half to six feet high cut them back to about four and one-half to five feet high. The next year after this is done, the first series of permanent fruit bearing laterals will come out within a foot or eighteen inches of the top of the leader. Select two to four of the best laterals in a permanent position and cut the others off. Leave some of the low laterals for temporary bearing. These can be cut off after they have borne four or five years. The strong inside shoots that come inside the tree opposite the first series of permanent laterals should be wrapped together to grow into living braces where needed. Cut the leader two or three feet above the first series according to the variety and the next year bring out a second series of permanent laterals. The idea is to have a permanent tree, with the fruit-bearing laterals in a permanent position, thus the tree has the maximum amount of fruit-bearing wood, a very important point for the fruit growers in a country where the trees bear so heavily. If this method is carried out it will not be necessary to cut large limbs out of the trees when they get older.

Summer Pruning

Tardy varieties and varieties that are slow to come into bearing should be summer pruned. The principal varieties in our district which require summer pruning are Spitzenburgs, Yellow Newtowns, Arkansas Blacks, Delicious and Stayman Winesaps. Most of the summer pruning is done when the trees are from three to seven years old, and is continued longer if necessary. The summer pruning should be done when the terminal buds swell. This varies with the varieties from the 20th of July to the last of August. At

summer pruning time four things should be done.

First: Make the cross ties or living braces if the tree is the right age, and the braces are necessary.

Second: Give the tree a normal thinning out or pruning.

Third: Make all the fruit spurs possible by forcing all the fruit spurs that have grown into shoots (leaving a cluster of leaves where the little shoot grew out); and all small whip growth in the bearing area of the tree, back into fruit spurs. Cut the fruit spurs that have grown on into shoots back just beyond the leaf cluster, leaving the leaf cluster to form the spur. Cut the little shoots that have no leaf clusters back to about four or five inches in length. About 75 per cent of these cuts will change back into fruit spurs the first year; those that do not should be cut again.

Fourth: Cut out the water suckers.

Proper summer pruning does not injure the tree. But by this one should direct some of the energy from growing into bearing. There is, however, much damage done by unwise and improper summer pruning. Unless the summer pruning is very accurately done and at the right time it is better not to attempt it at all. But when properly done the yield of some varieties may be doubled the first five years of bearing, and a better bearing habit for the future be given them.

Irrigating Young Trees

Too many growers irrigate young trees in the same manner as old bearing trees; they delay the early irrigations more or less and irrigate heavily later on. This is alright with old trees that have many roots and a large amount of moist soil to draw from; with the young trees, especially the newly planted tree, the roots are in contact with a very small quantity of soil. For this reason the ground should be irrigated often. Give the heavy irrigations early and frequently so that the young trees will get a quick early start. Cut the water down early enough in the fall so that they will

properly cure up for the winter, thus preventing to a large extent winter injury.

Pests on Young Trees in North Central Washington

Cut Worms and Weevils

Cut worms and weevils are among the worst pests on young trees in this district. They may be controlled absolutely by paper cone protectors made of two ply glazed paper. The shape of the paper when cut is that of a triangle with the peak cut square off. The size varies with larger trees, but for young trees the papers are cut six inches across the top; eleven inches across the bottom and seven inches high. Two of these are stuck together with a band of tree tangle foot across the paper. In this manner a man can take a large quantity of protectors in a basket. The paper when folded around the tree makes a cone with a band of tangle foot around on the inside of the cone. This protector makes it impossible for a cutworm or weevil to get up the tree and eat out the buds. A pin is stuck through the top of the cone and a small piece of paper adhesive tape is stuck across the bottom; these hold the cone in perfect shape and prevent any binding on the tree. It is a very serious injury and often absolutely ruinous to young trees to have the buds eaten out two or three times before the tree makes a growth. By this method of control these pests can be perfectly and inexpensively held in check. Where there are cutworms and no weevils and the condition is not bad enough to require protectors, cutworms are often controlled with poison bait made of bran, syrup and zinc arsenite.

Woolly Aphis

The object in mentioning woolly aphis is to urge the growing of tobacco to help in the control of this pest. I think this can be done in most of the fruit growing districts in the Northwest. The woolly aphis must be killed both on the tree and on the roots in the ground, in order to make a thorough job of it. They can be killed on the tree by spraying with crude oil or Black Leaf 40. To kill them in the ground throw the dirt back from the

crown of the tree and spray the roots with tree spray, then put two pounds or more of tobacco stems and leaves around the trunk of the tree just above where the roots join the trunk. This tobacco prevents the woolly aphis from going up or down from top to root or from root to top. The result is that the aphis are killed off the roots. This method has heretofore been impractical because the tobacco stems and leaves had to be shipped from the tobacco growing states, and the quality could not be depended upon. But by growing our own tobacco this problem is solved, and the control of the woolly aphis becomes comparatively inexpensive and easy.

Green Aphis

Green Aphis should be killed off from the young trees. This is done by spraying with Black Leaf 40 as soon as they appear and whenever they appear.

Borers

The flathead apple tree borer does considerable damage on newly planted trees. This pest may be controlled by paper cones made of magazine leaves. Simply take the leaf of paper, fold down the corner, make a cone around the tree; fit the cone tightly at the top and put a pin in to hold it; never use a string or wire as this may girdle the tree. Bury the bottom of the cone about an inch in the ground; this cone prevents the mother beetle from laying her eggs on the tree just at the surface of the ground, and the young borers can not get into the tree. After the tree makes one good growth there is then very little danger of borer damage.

Gophers

In addition to trapping and poisoning gophers, we have had considerable success catching them in pits dug in the orchard. These pits are dug six to eight feet deep and two or three feet across. Sometimes poisoned raisins with anise oil on them are put in the pits. Anise oil attracts all rodents. Whether the anise oil is put in the pits or not, a great many gophers fall in and die, being unable to get out.

R. EDWARD TRUMBLE

COMPOSITION OF APPLES

The following tables showing the composition of certain varieties of apples are the averages taken from more elaborate tables worked out by Alwood and David-

son of the Virginia Experiment Station

Apples vary in composition with the variety and slightly with the environment. This variation determines to some extent the uses to which they shall be put

Table No. 1—Percentages by Weights of Juice and Pomace of

	Juice	Pomace	Loss
Summer Apples—8 varieties ..	53.20	43.34	3 46
Autumn Apples—11 varieties.	53.92	43.95	2 13
Winter Apples—19 varieties	52.16	45.59	2 25
Crab Apples—7 varieties . . .	57.31	41.42	1 27

Table No. 2—Analysis of Juice from Same Samples

	Grams per 100 C. C.						
	Specific Gravity	Total Solids	Total Sugar	Reducing Sugar	Cane Sugar	Acid as Sulphuric	Tannin
Summer Apples..	1.049	12.33	9.53	5.85	3.50		
Fall Apples . .	1.054	13.76	10.66	6.93	3.53	0.36	0.069
Winter Apples. .	1.062	14.29	11.43	7.04	4.16	0.41	0.050
Crab Apples.. .	1.062	15.69	11.71	8.08	3.45	0.50	0.122

Table No. 3—Analysis of Pomace, Same Samples

	Grams per 100 Grams						
	Moisture	Ash	Total Sugar	Reducing Sugar	Cane Sugar	Acid as Sulphuric	Tannin
Summer Apples.....	83.29	0.37	8.66	5.49	3.00	0.33	
Fall Apples.....	80.81	0.37	9.12	6.32	2.66	0.32	0.055
Winter Apples.....	80.98	0.35	9.34	6.13	3.10	0.39	0.127
Crab Apples....	70.85	0.48	10.25	6.85	3.23	0.51	0.127

Table No. 4—Sugars and Acids in Whole Fruit, Same Samples

	Grams per 100 Grams						
	Total Sugar	Reducing Sugar	Cane Sugar	Acid	Total Sugar in Pomace	Total Sugar in Juice	Per cent of Sugar left in Pomace
Summer Apples.....	9.11	5.63	3.24	0.31	4.64	4.64	45.58
Fall Apples.....	9.94	6.58	3.11	0.34	4.38	5.42	44.08
Winter Apples.....	10.47	6.57	3.70	0.40	5.94	4.29	40.77
Crab Apples.....	11.10	7.54	3.38	0.49	4.26	6.73	38.33

Table No. 5—Moisture, Dry Matter, Ash, Nitrogen, Etc., in Whole Fruits

	Grams per 100 Grams						
	Moisture	Solids	Nitrogen	Ash	P25	K20	Ca0
Summer Apples	82 81	17 19	0 060	0 29	0 056	0 190	0 020
Fall Apples	87 90	12 09	0 045	0 22	0 016	0 115	0 0065
Winter Apples	85 38	14 62	0 056	0 26	0 023	0 155	0 009
Crab Apples	82 83	17 16	0 062	0 365	0 026	0 200	0 0095

UNFERMENTED APPLE JUICE

An inexpensive method of preserving apple juice so that the product will be free from objectionable sediment and a pronounced "cooked" taste, and can be kept in closed containers without the use of chemical preservatives, has apparently never been devised. Experimental work was undertaken with a view to developing such a method, and it is believed that a satisfactory procedure has been evolved. The main problems were: (1) The clarification of the juice, (2) the sterilization of the juice; (3) the carbonation of the juice; and (4) the question as to the best container for the sterilized product.

The Clarification of the Juice

Fresh apple juice contains notable quantities of solid matter, which will settle out on prolonged standing, forming a bulky deposit. In the case of raw juice this consists of dirt particles, starch grains, fragments of the cell walls of the apples, and, finally, albuminous matter, yellow-brown in color and very bulky. The albuminous matter composes by far the greater part of the sediment. The character of this sediment when heated to 140° to 158° F. (60° to 70° C) remains about the same, except that the starch grains are no longer apparent, the starch being wholly or partly gelatinized.

This sediment is very objectionable, since its presence seriously detracts from the appearance of the finished juice after sterilizing by heat. In the finished juice the albuminous matter forms slimy particles, yellow to dark brown in color, which very readily mix with the juice when agitated, and are slow to settle. The product looks as though the most un-

cleanly methods had been used in its preparation, whereas the reverse has been the case. The removal of the materials which form the sediment is, therefore, one of the most important steps in the preparation of a marketable product. The methods at present used for this purpose are two: (1) Filtration, and (2) sedimentation of the sterilized juice in large casks.

Filtration is expensive and slow, and, while a product of great brilliancy is obtained, the cost of the plant and the operation of the process will undoubtedly prevent its extended use. Paper pulp is ordinarily employed for the filter material, and the albuminous matter in the juice quickly forms a dense layer over the surface. The ensuing filtration is very slow, and a large filtering surface is required for practical use.

Sedimentation by gravity of juice heated to 140° to 158° (60° to 70° C.), and then allowed to cool in closed casks, is very slow. Unheated juice can not, of course, be used, owing to the fact that fermentation soon sets in. A period of five to seven days is required to produce a juice relatively free from sediment. At this time as much as possible of the supernatant juice is withdrawn from the sediment. The objections to this method lie in (1) the difficulty of keeping the juice sterile during the sedimentation period; (2) the large amount of cooperage required for any considerable output of juice, and (3) the fact that, owing to the bulk of the sediment, considerable quantities of juice can not be drawn off. The juice left with the sediment is then only suitable for vinegar stock. In addition only

partial clarification is secured. These objections to sedimentation are the result of numerous tests with barrel lots of juice.

A method of clarification which is free from the above objections, and is also cheap and may be applied on a small or large scale, is clarification by use of a cream separator. Repeated trials have shown that a cream separator can successfully clarify the juice, leaving only traces of sediment in the product. Absolute clearness of the juice is not produced by use of the machine, but practically all sediment can be removed by this process. In the experimental work to be described a hand-power cream separator of the disk type was employed. The first trial of the method indicated that a satisfactory clarification of apple juice could readily be obtained by use of the separator, and many further trials have confirmed these early indications. The suspended matter in the juice collects in the bowl of the separator, while the clean juice runs out through the milk and cream screws. After a run of the juice through the machine, the heavier particles originally present—the starch grains and any soil or dirt particles, together with some albuminous matter—are to be found tightly packed in the lower part of the tubular shaft in the bowl of the machine, while a heavy layer of albuminous material is invariably packed on the inner side of the bowl and a lighter layer on the inner side of the bowl cover. The disks remain quite free from sediment. When the space between the disks and the sides of the bowl is quite filled with sediment, the flow from the milk screw ceases and the flow from the cream screw is much increased. At this time the machine should be stopped and the bowl cleaned. The juice from the milk screw is invariably considerably cleaner than that from the cream screw. The reason for this is not apparent; the fact, however, was always observed. The juice from the cream screw is, in turn, much clearer than the untreated juice.

An extended series of tests established the following facts with regard to the

method of clarifying by passing through a separator, using unfermented juice and a machine of the size indicated.

First. The amount which may be run through the machine before it is necessary to stop and clean the bowl is from 25 to 40 gallons, depending on the quantity of sediment present in the juice.

Second. The rate at which the juice passes through the machine is about 45 gallons per hour, where a delivery tube of 450 pounds per hour (for milk) is employed. On fitting the separator with a delivery tube of 750 pounds capacity per hour, less perfect clarification was effected than when the smaller delivery tube was used.

Third. But very little increase in the degree of clarification or capacity for sediment was secured when juice heated to 140° to 158° F. (60° to 70° C.) was run through.

Fourth. When heated juice was allowed to stand over night and to cool and settle before passing through the separator, the supernatant juice contained much less sediment than the original juice and two to three times as much could be passed through the machine before cleaning became necessary than when unseparated juice was used.

Fifth. Two separations are necessary when working with a separator of the size employed. The first treatment removes the bulk of the sediment, and the second takes out nearly all of the remainder.

Sixth. Running the juice more than twice through the separator improves the character of the product but little, as only very small amounts of the suspended matter in the juice are removed.

Seventh. The best conditions, as worked out by experiment, for clarifying apple juice, are as follows, working with a hand machine with a capacity for milk of 450 pounds per hour.

(a) The juice must be freshly expressed and, to be of high quality, should be prepared from sound, well-ripened fall or winter apples.

(b) It should be received in a clean barrel or cask, which must not contain any fermentation residues. This point is

very important, as experience has shown that the very fine deposit formed in fermenting juice can not be successfully removed by the separator, and this deposit is difficult to clean from the sides and bottoms of fermentation casks.

(c) The juice is then passed through the separator, using the necessary precautions as to oiling and starting the machine, and turning the crank at the rate of 45 turns per minute. Twenty-five to forty gallons of fresh juice can be run through before the capacity of the bowl for sediment is reached. The juice which comes through the milk screw is collected separately.

(d) As soon as the milk screw becomes clogged the machine is stopped and the bowl is cleaned.

(e) The juice collected from the milk screw is passed through again and the juice then coming from the milk screw is collected as before. The clarification of 25 gallons of juice, using one machine of the capacity indicated and a juice containing sediment in such quantity that a run of that amount will fill the space between the disks and the sides of the bowl with sediment, requires about one hour and a quarter, the juice passing through the bowl twice.

The Sterilization of the Juice

As soon as the juice is clarified by the separators, it must be sterilized in closed containers. The points which have been carefully determined in this work have been the lowest safe temperature and the shortest period of heating for bottle and for cans.

If the juice is not to be packed and shipped, glass fruit jars, or bottles with patent stoppers, may be employed, but to stand shipping well, sealed cans or cork-stoppered bottles must be used.

Sterilization in Bottles

In the work with bottles, quart bottles of the champagne type were used. These were filled with clarified juice, some air space being left to allow for expansion of the liquid on heating. The bottles were placed upright and entirely submerged in water in a tank which could be heated

by a jet of steam. About fifteen minutes were required to bring the water in the tank up to the temperatures employed in the several sets of experiments, namely, 140°, 149°, and 158° F. (60°, 65° and 70° C.). After the bottles were placed in the tank from twenty-five to thirty minutes were required for the contents of the bottles to attain the temperature used. One-half hour was, therefore, allowed before beginning to count time in these tests—fifteen minutes to bring them both up to the temperature, and fifteen minutes holding at this temperature. The bottles were withdrawn at intervals and set away on their sides in baskets, being kept in a warm room whose temperature was quite constant day and night, between 70° and 75° F. The bottles were agitated and notes taken on them from day to day.

The results show that a temperature of 149° F. (65° C.) for one hour will give good results and that 158° F. (70° C.) for one-half hour also gives good results. Only a very slight cooked taste is given to the juice by heating at 158° for one hour—slightly more, however, than is given by heating at 149° for the same period.

Sterilizing in Cans

One-gallon packers' cans were employed. These were first carefully rinsed with water, filled, sealed (rosin dissolved in alcohol being used as flux), and then heated in the same manner as the bottles. The juices employed were thoroughly typical and were clarified by passing twice through the separator. A full half hour was found by a careful test to be necessary for heating the contents of the can up to the bath when the water in the bath was cold to start with, and this period was only slightly shortened when the bath was hot at the time the cans were placed in it. Unfortunately, the periods of heating were not short enough nor the temperatures used low enough to indicate unsafe conditions, since none of the cans spoiled; but proper treatment was found to be very readily given at low temperatures and for brief periods. It was expected that the cans which were

only heated up to 149° F. (65° C.) in the hot water and then removed would surely spoil. These cans remained sound, however, and thus the period of heating indicated as sufficient for canning is unexpectedly short. When the cans were removed, they were cooled over night and allowed to stand in the same room as that in which the bottles were held. Owing to the large bulk of juice in the cans of the size employed (1 gallon), it is evident that the juice was maintained at a sterilizing temperature longer than if bottles or small-sized cans had been used. This fact must be kept in mind if the results here obtained are applied to other sizes than gallon cans.

The Carbonation of the Juice

In addition to experimental work on clarifying and on heating the juice, investigations were made on carbonating it with a view to disguising the slight cooked taste which it is impossible entirely to avoid. Carbonating also increases the palatability of the juice in the opinion of many persons. The method used consisted in carbonating the juice under slight pressure and then heating in bottles or cans, and no difficulty was encountered. In the simple experiments devised and carried on in connection with this work, the carbon dioxid (carbonic acid gas) was secured from a firm handling soda-water supplies. It was obtained in liquid form in a steel cylinder furnished with a reduction valve and a gauge and delivery tube, so as to deliver at pressures up to 30 pounds. After clarification, the juice was carbonated by pouring it into a clean keg and running in the gas up to a pressure of 15 pounds.

The keg was provided with a thick pine bung, through the middle of which was bored a half-inch hole, which received the rubber delivery tube from the cylinder of compressed gas. The bung was soaked in water for a few minutes before use, so that it could be driven in to make a tight joint, and was so fitted that it projected beyond the surface of the keg and could be readily loosened when carbonation was finished. About

12 gallons of juice were poured into the keg. Carbon dioxid was admitted before driving the bung in airtight in order to expel the air which fills the space in the keg not occupied by the juice. The bung was then driven in by tapping with a hammer and more gas admitted. The keg was vigorously rocked so as to thoroughly agitate the juice and so accelerate the absorption of the gas.

The gauge was watched, and in these experiments the pressure was not allowed to go beyond 15 pounds per square inch. The juice used in the carbonating work was quite cool, ranging from 48° to 68° F. (9° to 20° C.) in the different experiments. As the carbonating of liquids is apparently well understood, no attempts were made to correlate the pressure, temperature, and amount of gas which could be dissolved in the juice. In these experiments the juice was carbonated at a pressure not exceeding 15 pounds until a sample was drawn tasting distinctly of the gas, this being the amount of carbonation desired. Working under these conditions in the different trials, from fifteen minutes to one-half hour was required to carbonate 12 gallons of juice. The stream of gas was then stopped, the bung cautiously loosened, the contents of the keg poured out, and the juice bottled or canned.

The gas remains for some time in the juice when under atmospheric pressure and only gradually diminishes in quantity, so that great haste in sealing the juice is not necessary. If the carbonated juice is to be sterilized in cans they must be heated in stout frames to prevent distortion of the can while hot and consequent bursting. The finished canned product bulges the ends of the cans to some extent, but not enough to cause permanent bending. The juice must not be too highly charged with the gas nor removed from the frames while still hot, or such bending, with consequent weakening of the soldered joints and bursting of the can, may occur.

The Best Containers for Sterilizing Juice

In the work with juice treated as above described, bottles and cans have been

used as containers. The other containers which might have been tried were barrels or kegs and jugs. Owing to the great liability to leakage and consequent infection of juice when treated in barrels and kegs, these containers are considered impracticable when the juice is to be kept indefinitely. Jugs are considered to be too cumbersome and at the same time too fragile to be handled readily in comparison with cans.

For bottles, sound corks, well soaked in hot water, should be used. These can be wired in before the bottles are heated; or tin cork holders, which may be bought on the market, may be used. The exposed end of the cork should be dipped in hot paraffin or hot grafting wax after heating, to prevent the cork from drying out with consequent serious danger of infection of the bottled juice.

No trouble was experienced in sealing the cans. As previously noted, standard 1-gallon packers' cans were employed. These had a 2 7-16-inch opening and were filled to within about one-quarter inch of the opening. The can was then wiped and the flux, consisting of rosin dissolved in alcohol, was applied. Hemmed caps were employed for sealing—that is, the tin cover which fitted over the opening in the can was fitted with a rim of solder. For sealing the can, a capping steel and soldering copper are required, also a gasoline furnace for heating the steel and copper, and a supply of flux, solder and sal ammoniac.

Barrels and kegs can be successfully used as containers for sterilized juice when it is desired to keep juice sweet for a limited period of a few days or weeks. The cask must be thoroughly cleaned and well steamed, and filled with the juice heated to between 149° and 158° F. (65° to 70° C.). The cask can then be bunged, but considerable contraction takes place on cooling, with resulting strain on the cask and consequent increase in the danger of leakage. It is a much better procedure to close with a clean cotton plug, and when the cask and contents are cool to remove the plug and quickly insert a

wooden bung which has been sterilized by soaking in alcohol. Two experiments were carried on with success with 50-gallon barrels, following this procedure. This juice kept for ten days without showing fermentation. At this time the barrels were emptied and used for other purposes.

In the experiments with barrels, and in all other work in which the juice was heated except in bottles and cans, a pasteurizer designed by Mr. Given, of the Bureau of Chemistry, was employed. It proved to be a very useful machine and was capable of heating the juice with perfect control of temperature at any desired rate up to several hundred gallons per hour.

The cost of handling apple juice when it can be obtained perfectly fresh in clean barrels is slight. The only expense of separating the juice is for the labor, and if a small steam generator be used in connection with a turbine separator this cost can probably be lessened. Bottles of the champagne type cost from 3 to 5 cents each, and gallon cans cost from 4 to 5 cents each in lots of 1,000. On account of the acid nature of apple juice, the cans employed should be made of a high grade of tin plate and, as with other canned products, the juice should not be allowed to stand in the can after opening. With a view to lessening the action of the juice on the walls of the can, lacquering the inside of the can with a vegetable gum was tried. Considerable less action of the juice on the tin was noted when the lacquered can was used.

Sterilizing requires a tank of water which can be heated by steam or in any other way so that it can be easily maintained at the desired temperature. The apparatus for carbonizing is simple and cheap, and the method is easy of application.

The chemical work in connection with the experiment has been to determine the composition of the juices employed and the effect of the treatment on the composition of the juice. The results of this work show that the chemical composition is practically unchanged by the treat-

ment of clarifying, carbonating, and heating.

See *Cider*.

H. C. GORE.

Of the Bureau of Chemistry, Washington, D. C.

THE POLLINATION QUESTION

Every practical orchardist has now come to realize, or if he has not, he should, that one of the most important phases of orcharding is the problem of pollination. It must be considered in selecting any variety for planting. The question has been one of scientific interest for many years and unfortunately considerable has been written on this subject before definite information was at hand, with the result that many of the recommendations of today must be considered without foundation.

Too many times one is prone to consider that any lack in the setting of fruit is purely and wholly due to the absence of proper pollination. As a matter of fact there are many causes other than pollination which must be taken into account. Among the first of these we may mention the inability of certain varieties to set fruit, or of certain spurs on the tree to mature fruit from the blossoms which occur on them in the spring. To drop their fruit seems to be as much a character of certain varieties as is the color, flavor, or any other character of the variety. From carefully conducted experiments we must conclude that by no means is all the spring and June drop to be attributed to lack of pollination.

Another one of the important causes of dropping of blossoms is the vegetative vigor of the trees. If a tree is growing too vigorously it frequently runs entirely to wood and scarcely produces any blossoms, and the few that it may produce are usually shed very soon after the blooming period is past. The same may be said of trees which are in a very poor condition. While the latter may bloom more profusely than those which are growing vigorously, some blossoms are as incapable of setting fruit as are those on the former.

Insects and diseases also frequently

cause the loss of many blooms. Some are destroyed outright by the various diseases, such as scab, anthracnose, or blight and in the case of peaches and plums by the brown rot fungus. Many blossoms may be ruined when quite young by attacks of insects. Even some of the blossoms which may be set are later killed by these same causes before they have made any considerable size and are frequently shed at the time of the so-called June drop.

It is almost too well known to need mentioning that rain or snow during the blooming period is the cause of failure of many blossoms. This loss is due to the fact that much of the pollen is destroyed by rain and the stigmas of the blossoms are injured to such a degree that pollination and consequent fertilization is impossible. Of course no fruit is produced under such conditions. In this connection, however, it may be well to mention the fact that usually all the blossoms do not come on at the same time and enough may meet with favorable conditions to produce a fair crop.

One of the most serious climatic conditions with which we must contend is frost. Injury from this cause is brought about in two ways: first, by winter freezes and second, by spring frosts. In the former instance the fruit buds are either killed outright during the winter, or are injured only to the extent that they are incapable of producing fruit. That is, the flowers expand and without careful inspection appear normal, but on closer examination it is usually found that the pistils or heart of the very young fruit has been killed. Injury from late spring frosts is manifested in various ways. The young fruit is subject to injury from the time the fruit buds have opened until the time the fruit is as large as a garden pea or even later. If the frost is very severe the young fruit is generally killed outright as is recognized by a very noticeable blackening a few hours after the frost. In certain instances, generally after pollination has occurred, a light or medium frost does not entirely kill the blossom but seems to allow a certain degree of development. Usually in such in-

stances the seeds are killed and there is little or no development of them, though there may be some. Usually such fruit develops somewhat abnormally, frequently producing in pears what is described as 'bull-neck.' Such fruit will usually hang on the trees up to the time they are ready to make the last swell before picking time, then they will drop in quantities. Often if not too badly injured they will develop sufficient size to be marketable.

Another cause of the shedding of some fruit, though probably in general of an inconsiderable quantity, is the spraying of trees when in full bloom. Careful experiments conducted along this line by several experimenters have demonstrated that when the trees were thoroughly sprayed before the blossoms had been pollinated they failed to set fruit. Usually, however, if two or three days have elapsed after pollination and before the spraying, such fruits will set perfectly. Furthermore, on most varieties the blossoms open at intervals for several days and one spraying would not be likely to injure all the blossoms in any one cluster.

It will be seen from the foregoing and as pointed out above that we must take into consideration several factors other than pollination when we are looking for the cause of failure of blossoms to set. However, we think it is safe to say that all varieties of pome fruits, at least apples and pears, even though the varieties are termed self-fertile, are benefited by having other varieties planted with them as pollenizers. By the term self-fertile variety we mean one which is capable of setting perfect fruit without the aid of pollen from another variety. By self-sterile we mean that a variety is not capable of setting fruit without some other variety being planted with it to furnish pollen. One frequently meets with the term partially self-fertile, or partially self-sterile. By this is meant that under certain conditions a limited number of fruits will set. By far the greater number of our varieties must be classed in the self-sterile or partially

self-sterile list and as above pointed out it is always best to plant two or more varieties together. However, we must guard against planting too many varieties. One variety as a pollenizer for another will serve every purpose that twenty would. Thus an orchard of Bartletts and d'Anjous would serve to pollinate each other as well as if we planted among them a dozen or more varieties. In the past one of the greatest difficulties has been that the orchardists have gone on the supposition that if a little is good, more will be better and some have planted all the way from fifteen to twenty varieties, many of them worthless, merely for the sake of securing cross-pollination. This is a mistaken idea and one that should be guarded against. Of course, if one wishes to grow a number of varieties for other reasons there can be no objection from a pollination standpoint but otherwise it is to be avoided.

The main point that must be taken into consideration in the study of the pollination problem is the so-called secondary effect of pollen. By this we mean the effect let us say, of Spitzenburg pollen on a Newton apple in the immediate cross. Much has been written for and against the use of certain pollenizers and we believe that we must conclude that in general there is very little effect other than a change in size of the fruit, increase in percentage of set, and uniformity of crop. Flavor, quality, keeping quality and color are probably not affected in the least.

This subject has been discussed from the earliest times, ever since the pollination problem has begun to be investigated, but from carefully conducted experiments the last several years we believe that we must conclude that if other noticeable effects are manifested they are exceptionally rare indeed. The same conclusions have been reached by other very careful workers along this line. Too much credence has been placed in sporadic instances of apparent effect. Thus we frequently hear that if a Spitzenburg apple has a bright yellow band from

calyx to stem, it is considered to have been pollinated by a Newtown, or if a Ben Davis has a similarly placed dark red band, that it was pollinated by a Baldwin. These suppositions must be held to be false and the effect attributed rather to bud variation. We have met with many instances of this sort and are forced to conclude that the pollen which was used had absolutely nothing to do with the color. Soil, the methods of pruning, fertilization, cultivation, irrigation and other orchard practices will influence color, quality, etc., far more than will the pollen of neighboring varieties. As had been mentioned, the three greatest factors influenced by pollination, are size, percentage of set, and uniformity. Certain varieties of pollen may possibly produce, when applied to any given variety, a smaller fruit than normal, and certain other varieties may produce a larger fruit than normal. One of the points that should be emphasized in this consideration is that cross-fertilized fruits generally produce more seeds than do those which are self-fertilized and furthermore the greater the number of seeds usually the greater the size and weight of the fruit itself. In fact, seed production seems to be the exciting cause of the growth of the flesh of the fruit. Often in self-fertilized fruits, while the fruit will come to full maturity, it is not more than a fifth or quarter of the size of a cross-fertilized fruit and is generally seedless. Cases of fruit production without pollination are recorded, but among the pomes at least, this condition must be considered exceptional.

It may be well also to call attention to the fact that pears will not serve to pollinate apples nor will apples pollinate pears, though the various species of apples will interpollinate and the same holds true for pears. Cherries, plums, or peaches also cannot be considered in any way to serve as pollenizers for either apples or pears of any variety.

The question then arises, what are the essentials of a good pollenizer. First of all we may say that the two varieties must bloom at the same time. That fact

is self-evident for if one variety is out of bloom before the other begins it may as well not be there so far as furnishing pollen is concerned. Second, the two varieties must have an affinity for each other. That is to say, the pollen of one must be acceptable to the pistils of the other; and such as is going to give the best and most uniform fruits and greatest percentage of set. Third, both must be good pollen producers. If a shy pollen bearer is planted with an abundant pollen bearer, the variety which produces little pollen will, of course, be greatly benefited, but there will be little reciprocal action, as is readily seen. Such an example would be the planting of the Winesap and Rome Beauty. The Winesap produces very little pollen, whereas the Rome Beauty produces plenty. The former, therefore, would have an abundance of Rome Beauty pollen to fall back on, but the Rome Beauty would stand slight chance of being crossed by the Winesap. Fourth, both varieties preferably should be commercial. This is simply, of course, a practical point in economics. Fifth, both varieties should come into flower at about the same age. For example, were the idea to pollinate the Wagener with Northern Spy, the result would be that for several years the Wagener would be without a pollenizer, in that it comes into bearing much earlier than the Northern Spy. Such a discrepancy can be made up in a measure by the use as fillers, of dwarf trees of the late bearing variety. Such dwarfs will bear several years in advance of the standard and later can be readily removed.

Careful experimentation has shown that very little, if any pollen of our tree fruits other than nut trees, is transported by the wind. Probably 99 per cent or more of the transfer of pollen is done by insects. Prime among these may be mentioned the honey bee. Bumble bees, ants, flies, moths and short-tongued bees play an important part. However, there is no doubt but that the common hive bee is by far the best of all, and it will pay every orchardist to have a few stands among his trees.

In putting out an orchard the system

recommended to secure the best results from pollination is to plant four rows of each variety, be there two or more. Such an arrangement would allow for convenient harvesting, pruning, etc., and serves better than planting four and one, which is sometimes recommended. Of course, so far as pollination is concerned, the latter arrangement is entirely permissible if one wishes to grow a larger proportion of one variety than another, but in general if one can have the varieties blocked more or less many of the orchard operations will be simplified. For, as is well known, the several varieties frequently require quite different attention. To illustrate, if the Bartlett were not used to pollinate d'Anjou pears, and the same were planted four rows of d'Anjou to one of Bartlett, it is readily seen that the Bartletts must be harvested earlier than the d'Anjou with the result that there would be considerable tramping and hauling through the latter, thus not only compacting the ground unnecessarily, but also incurring the risk of knocking off fruit, disturbing props, etc. Many similar instances could be cited.

While by no means complete, the following list of commercial varieties most grown at the present time are grouped according to the desirability of interplanting to secure best results from pollination. Any variety occurring in any column is well pollinated by any one or more of the varieties in the same column.

Apples	
Early	
*Gravenstein	Tetofski
Oldenburg	Wealthy
Red Astrachan	*Yellow Transparent
Late	
Arkansas Black	Red Cheek Pippin
Baldwin	Rome Beauty
Ben Davis	Spitzenburg
Black Twig	Wagener
Gano	Willow Twig
Grimes Golden	Winesap (a shy pollen producer generally)
Jonathan	White Winter Pearmain
McIntosh	
Newtown	
Northern Spy	
Ortley	Yellow Bellflower

* In many localities these varieties bloom sufficiently late to serve to pollinate many of those listed as late bloomers.

Pears

Early

Bartlett	Howell
Clairgeau	Keiffer
d'Anjou	

Late

Angouleme	Easter Beurre
Bosc	P. Barry
Du Comice	Winter Nelis

It must be remembered in this connection that in general, the greater the altitude, or the farther north varieties are grown, the later in the season will be their blooming periods and that the so-called early bloomers come very little in advance of the late bloomers. In milder climates or lower altitudes these same early varieties may be entirely out of bloom before the late varieties begin. Thus, also, it may be found, especially among the late bloomers, that certain varieties in certain localities will bloom nearly or entirely together and in other localities they will bloom nearly or entirely together and the entire blooming season shortened. The lists are based on general Oregon conditions for a normal season.

LABORATORY FOR HORTICULTURAL RESEARCH,
May 2, 1912 Corvallis, Oregon.

Problems in Orchard Pollination *

The idea of mixing varieties to insure pollination is not a new one. Darwin has taught that "Nature abhors perpetual self-fertilization;" that "It is injurious and results in inferior and less fertile offspring," and that "Plants are endlessly modified to insure cross-fertilization." Just how much the apple is modified to secure crossing of varieties will be seen later.

It has long been the practice of California prune growers to mix their varieties. Waugh (Vermont Experiment Station Report, 1897) found that most vari-

* The necessity of accurate and scientific information concerning the pollination of our common fruits is recognized by everyone who has given the subject a moment's thought. In the work done by the Horticultural Department of the Kansas Experiment Station the peach, plum, grape and apple are the fruits upon which the most data has been collected. The above article is based upon the work done by Mr. Geo. O. Green, assistant in horticulture, and submitted by him as his thesis in his work for the degree of Master of Science.

eties of plums are self-sterile; Waite (U. S. Division of Vegetable Pathology, Bulletin 5) shows results of many experiments carried on with the pear to show the affinity of certain varieties for the pollen of certain other varieties. Some of the most interesting discoveries made by Waite are, that the descriptions given by Warder, Thomas and Downing were true only for the fruits resulting from cross-fertilization; that the fruits from cross-fertilization were much larger and that the flavor was much better in the crossed varieties than the fruits resulting from self-fertilization.

Everyone has noticed that isolated fruit trees failed to bear fruit though they blossomed full each year. The Wild Goose plum is a very good illustration of this self-sterility in fruit trees, familiar to everyone who has planted this variety in isolated positions.

This self-sterility, as it is called, is the inability of the pollen of a plant to fertilize its own ovules or those of other plants of the same horticultural variety and is indicated in fruit trees by the continued dropping of the fruiting organs before the fruits have become well formed, although fruits often drop from other causes, as frost, general debility of the tree, etc.

No one can say why a variety should refuse its own pollen and accept that of another variety. Accepting Darwin's law that "Perpetual self-fertilization is injurious and results in inferior and less fertile offspring," we would admit, that, in the countless ages of the selection of the apple, inferior offspring and, perhaps, the entire loss of fertility has been avoided by self-sterility. In the apple, self-fertilization has been guarded against in different ways, as will be seen in the descriptions and experiments which follow.

Definition of Terms Used

Self-sterility: Inability of pollen to fertilize ovules of same horticultural variety.

Self-fertile: A plant is said to be self-fertile when the pistil will accept pollen from a plant of the same horticultural variety.

Cross: Union of pollen cell and ovule of two distinct horticultural varieties. In no case is it meant the transfer of pollen from one flower to another on the same tree or from one flower of a variety to the pistil of another individual tree of the same horticultural variety.

Pollination: Act of transferring of pollen to the pistil.

Fecundation: Union of pollen cell and the ovule.

Fertilization: A general term to include both the preceding terms.

The flower of the apple is regular and perfect in all of its parts; petals and sepals five, petals varying in color from

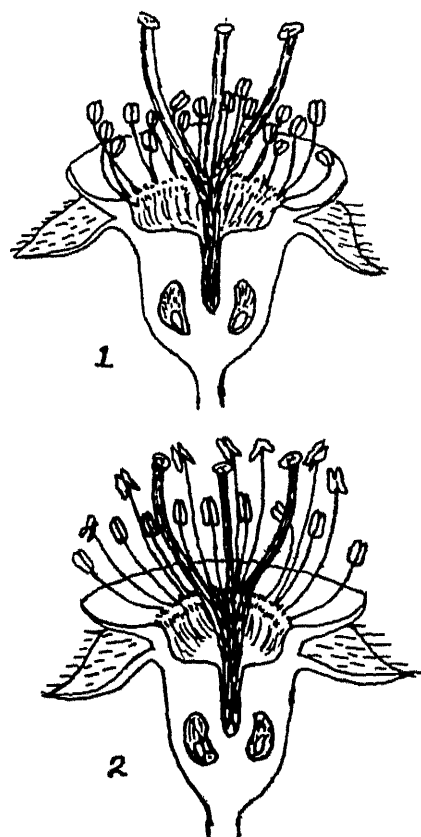

Fig. 1. No. 1. Cullen Stamens Before Dehiscing. No. 2. Cullen Outer Row of Stamens Dehisced.

a pure white to a faint rose; stamens 20 or less, filaments of two lengths, one set of anthers ripening later than the other (see figure 1), anther two-celled dehiscent along the outer margin, the two cells not always dehiscent at the same time but the dehiscence of both taking place within a very short period; pistils ripening before the stamens, stigma extremely papillose and in a condition to catch and retain pollen before it is receptive, though it is in a receptive condition as soon as the flower opens; stigma secreting a sticky fluid which also aids in holding pollen

falling on the pistil, much more of the fluid being secreted by the pistil if the stigma is not pollinized with acceptable pollen than would be if it were fertilized as soon as receptive; pistils remaining erect and fertile for several days after maturing if acceptable pollen is not applied to them. Upon the reception of pollen the pistil wilts in a very few hours, or at most, in the course of a day.

In the bud the stamens are turned inward toward the center of the flower while each pistil is recurved on the style. The pistils are the first to assume an erect position, as may be inferred from their early ripening. The ovary is inferior, inserted below the calyx. Figure 1 shows the position of the parts of the flower. The flowers are sidewise, turning toward the light, thus preventing wetting of the pollen and insuring self-pollination if no pollen is brought from another flower. Although Nature has made self-fertilization mechanically possible in the apple, she has made self-fecundation impossible in the majority of cases, and experiments go to show that self-fertility is the exception and not the rule. These experiments also show that these self-fertile varieties are safe ones to use for the fertilization of other self-sterile varieties.

Causes of Failure of Blossoms to Set Fruit

Some of the causes of failures of orchards to set fruit are here enumerated.

1. The trees or the blossoms may be injured from drought.
2. The fruit buds may be injured from winter freezes.
3. The fruit buds may be injured from late spring frosts.
4. The blossoms may be injured from a lack of proper nourishment.
5. The tree may fail to bloom from an excess of certain kinds of nourishment.
6. Fruits may fail to set from improper pollination.

1. *The trees or the blossoms may be injured from drought.*—It sometimes happens that a very wet spring with such

weather as will stimulate the trees into a very strong growth during the earlier part of the growing period is followed by a summer and fall of extreme drought. Under such conditions the fruit trees are unable to set fruit buds with sufficient vitality to carry them far enough to form fruit. Fruit buds make heavier demands on the tree than leaf buds. After such extremes as the above the tree uses its whole energy to recover its vegetative power, and it may often happen that a tree will fail to set fruit from this cause.

2. *The fruit buds may be injured by winter freezes.*—It is impossible to say just how much freezing the fruit buds of the apple will stand. In sections of this country, where the air is less dry than in the West, the buds will stand a much lower degree of temperature than they will in our dry atmosphere and a very low temperature of one winter will have less of an evil effect on the fruits of our region than another winter when the thermometer does not record so low a degree of temperature. There are so many influences that affect the formation of fruit buds and their proper nourishment that it is impossible to say how far and to what extent freezing affects the next summer's crop of apples. The vitality of the buds, their maturity, the condition of the atmosphere as to moisture, the amount of moisture in the soil, and the amount of snow on the ground are a few of the things we must consider.

3. *The buds may be injured by late spring frosts.*—The amount of injury to buds from frosts cannot be computed; a few days before or after the blossoming period may make an untold amount of difference. Buds that have been injured by frosts may yet have enough vitality to bloom and yet not have enough to set fruit. Some buds, from their position, their state of maturity, or because they are more hardy, may be less injured than others on the same tree. Varieties considered tender may be able to set fruit after experiencing an unusually heavy frost, yet fail the next year when

lighter frosts have touched them. The advancement or retardation of the buds may account for this. Though neither the pistil nor the stamens are badly injured by the frost, the ovary may be so badly injured that fecundation is impossible. Heavy frosts during the blossoming period may so impair the fruiting organs as to cause the dropping of the fruits after they have set.

4. *The trees may lack proper nourishment.*—This may be from a lack of water or it may be from a lack of other plant foods. Orchards which have been improperly cultivated, or which have grown heavy crops of apples and have not had the elements removed by these crops returned, may fail to set fruit buds in the proper manner. In an experiment with pollen from an improperly nourished Missouri Pippin, it was found that this pollen was very much less potent than the pollen from a more thrifty tree. Poorly nourished trees were found to be more liable to self-sterility. Many orchards set in the early history of the different sections have ceased bearing, in all probability from the effects of continued starvation, and many other younger orchards fail to set fruit from the same cause.

5. *The trees may fail to set fruit from an excess of certain kinds of nourishment.*—The above may be the case or they may have plant food at the wrong season of the year. It is a well known fact that the reproductive and the vegetative powers of a tree are exercised in direct opposition to each other, and a tree making too great a vegetative growth is liable to be barren. This is especially true of orchards planted close to barns, feed-lots or corrals, where the owner is in the habit of dumping manures. Under such favorable conditions to the development of the vegetative portion of a tree, it would be much longer in reaching maturity and would never bear as well as another tree planted in soil with nearer the optimum amount of plant food or with plant food better adapted to its needs. On such a tree the fruit buds would be few and

would go into winter in an immature condition, with few chances of escaping winter injury. Orchards may fail to set fruit because of too great a growth during the season when fruit buds are forming. A later fall growth may open the road to winter injury because of improper ripening of the wood. Winter killing of the immature wood, together with the fruit buds, is very often the result.

6. *Blossoms may fail to set fruit from improper pollination.*—Though the trees may be in perfect health, the winter may not have been severe and the orchard may be a mass of bloom, there may be only a fraction of a crop. Isolated trees which are self-sterile cannot set a full crop of fruit because so few bees, the only agents of pollination acting at a distance, visit two trees very far apart during the same absence from the hive, and very few of the blossoms would thus be fertilized. The same would be true of large blocks of trees planted to single varieties. The bees would carry little else than the pollen of that variety. Another case of improper pollination is noticed when the weather is damp and cold during the blossoming period. Such weather prevents the work of bees and often causes the germination or the decomposition of the pollen grains. Even when the pollen grains are not entirely spoiled, may it not happen that when slightly wet pollen falls on the stigma it possesses just enough vitality to germinate and start fecundation, but not enough to carry it through all the changes necessary to complete fertilization? If such be the case, the pistil after responding would waste away. Vigorous pollen would thus be prevented from fertilizing the pistil, when the weather became bright and warm enough to properly ripen the pollen and bring out the bees, and fruit would fail to set as it should.

Dry, hot and windy weather may so badly injure the stamens that they cannot properly mature their pollen or it may cause the dehiscence of the anthers before the pollen is mature. The same

theory may be applied to the partial fecundation of the ovules by pollen injured in this manner as that injured by wet and cold

Pollen grains may be entirely washed away during extremely wet weather or blown away during dry periods. High winds may waste the greater amount of pollen and may, during very hot weather, when the pistil is in a receptive condition, so entirely dry up the fluids secreted by the stigma as to make germination impossible or even blow away what pollen is held by the stigma by reason of its roughened surface. Dust storms during the time when the pistil is receptive may make pollination impossible from the fact that the papillose stigma catches dust particles which absorb the juices there secreted and thus covers the stigma with a coating of very fine particles of dust firmly cemented together by this sticky fluid.

Several years ago Prof. W. J. Beal, of Michigan, published a series of articles on the classification of apples by their flowers. Pomologists gave little attention to the work and nothing has been heard of it since. Orchardists need a more scientific and systematic classification than is offered by Thomas, Downing, and Warder, who base their classification on season or color. In the study of the forms of blooms and the size and shape of the organs of the flowers, it was found that each variety possesses definite characteristics that might be used to distinguish it from other varieties. These characteristics are often modifications to insure pollination or to prevent self-fertilization, as in the case of Grimes Golden, in which the pistils recurve outward, as shown in Figure 2. In some of the flowers of this variety this character is developed to such an extent as to make self-pollination absolutely impossible. The position of the pistil also insures pollination from visits of bees. Other forms of pistils are shown in the Ben Davis, which has a very straight, upright pistil, and Smokehouse, which has a very large knobbed pistil.

These modifications of pistils, the

habits of the anthers in dehiscing, the shape, size and color of the flower, the fruits and the definite characters of the lately introduced Russian varieties, all offer a basis of scientific classification of the apple. This classification might be in groups, possessing certain characters, much in the same way as Waugh has classified the "Apples of the Fameuse Type" (Vermont Experiment Station Bulletin 83, 1900). Such a knowledge of relationship might be used to insure wider crosses and greater fruitfulness in

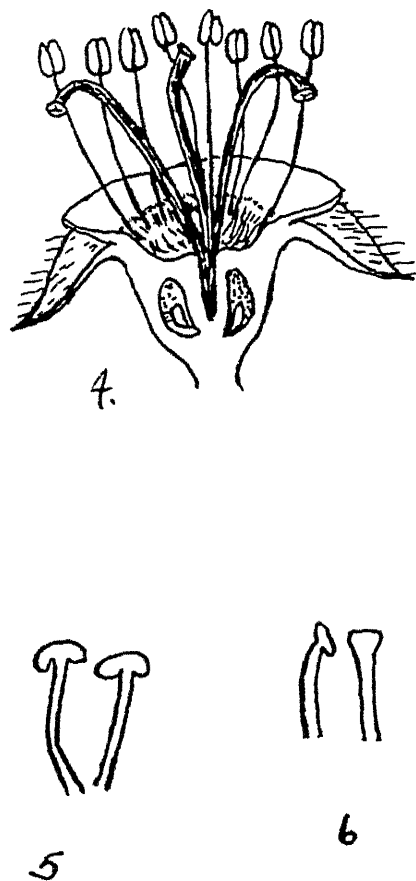

Fig. 2 No. 4. Recurved Pistils of Grimes Golden. No. 5, Pistils of Smokehouse. No. 6, Pistils of Ben Davis.

our orchards rather than the present haphazard method of planting very closely related varieties near each other. These characters might well lead one to think that Winesap, Arkansas Black, Mammoth Black Twig and, perhaps, Benoni, are closely related.

Agents of Pollination

During the years of especially favorable weather and when all things are in the proper conditions for the largest crops and the greatest fruitfulness, the apple seldom sets more than from four to seven per cent of the flowers borne.

The conditions must be favorable beyond expectation when ten per cent of the flowers set fruit. A correspondent asks why more apples were borne on the north side than on the south of his trees in the summer of 1901. Taking the bloom chart for 1901 and comparing the directions of the wind during the days when the trees were in bloom, it will be seen that the wind held steadily southwest, blowing from five to 20 miles per hour. The question then arose as to why the blossoms on the south side of the tree were not fertilized by the wind carrying pollen from the tree directly south of it in the same row, if the wind is an agent of pollination. The theory was advanced at the time that perhaps bees did most of the work of pollination and worked out of the wind. Later experiments have gone to show that this is largely true, though they do work in the wind. During the blooming period of Huntsman, when it was not blowing a gale, the wind was south or east. To find out how much truth there was in the above theory, the bees were counted on each side of the tree in a hasty way so as to count as few as possible twice. During the time when Huntsman was in full bloom, with an east wind and the sun shining warmly, there were counted 20 bees on the west side and eight on the east. Taking the same tree with a wind blowing at a rate of about seven or eight miles an hour from the south and small "choppy" clouds flying, there were counted 16 bees on the north side and five on the south. On April 30 Kinnaird was in full bloom and an east wind was blowing at a rate of 10 or 12 miles an hour. The day was warm and sunny and the bees were out in force. Five bees were counted on the east side and 10 on the west of one tree and on another of the same variety four bees were counted on the east side and 16 on the west. These figures cannot be laid to the bees' preference to sunshine or shade as they worked in the full sunshine in one case and in the shade on another. There was not much difference in the temperature for the different days.

By watching the bees during the time when the work of pollinating the flowers was being carried on, it was noticed that in every case the bees chose the side of the tree most protected from the wind. The honey bee was the principal visitor, though other bees were noticed to be at work. But two bumble bees were noticed during the whole week that the work was being carried on. Six species of bees were noticed at one time at one tree. Bees were noticed to visit the same flower five or six times during the course of 15 or 20 minutes, and it is safe to say that each flower was visited 25 or 30 times during the day, and could scarcely have escaped pollination from this source. Many other insects were seen to visit the flowers to eat the pollen, to gather honey or to prey on other insects. In any case they may have, to some extent, aided in pollination. The greatest agent of pollination is undoubtedly the honey bee, though in its absence other species would carry on the work to such an extent as to insure a crop of apples were the weather favorable for the work of bees during the blooming period.

To ascertain the extent to which the wind is an agent of pollination, microscope slides were set in the orchard to catch pollen. These slides were prepared by smearing them with pure glycerine. The slides were numbered and the height and distances were recorded for that number. Afterwards these slides were taken in and examined with a microscope to find how many pollen grains had been caught. The days when these slides were put in the orchard were ideal for pollination. The sun was shining and a great many anthers were dehiscing. The wind was blowing at a rate of about five or six miles an hour. The slides set very near a full blooming Rome Beauty were left four hours. Number one was set at a height of about six feet and 20 feet away from the tree, but one grain of pollen was found to adhere to it; number two at eight feet high and 12 feet from the tree caught but one pollen grain; number three at a height

of three feet and 15 feet from the tree caught but five grains.

On April 28 slides were set near a very full blooming Kinnaird and left seven and one-half hours in a wind blowing four or five miles per hour. Number four was set at a height of six feet, 15 feet from the tree, and caught 10 grains of pollen. Number five was set at a height of six feet, 25 feet from the tree, and caught but three grains of pollen. Number six, at a height of three feet, 15 feet from the tree, held five grains of pollen. The same day slides were set near a tree of Cullen and left for the same length of time, seven and one-half hours. Number seven was set at a height of eight and one-half feet, 33 feet from the tree, and caught but seven grains of pollen.

From foregoing results it will be seen that the wind does aid in pollination. The reason why more grains of pollen were caught by the slides further away from the tree than those close to it is because the grains of pollen hold together to some extent until they are blown apart by the wind. Though this is all true it cannot be expected that the wind is much of an agent in the pollination of orchards. To illustrate, let us compare the apple with the pine. The pine is fertilized almost entirely by the wind and without doubt there are as many pistils to fertilize in pine as in the apple; yet, though there are showers of pollen from the pine that make the ground yellow, some of the pistils escape fertilization, as will be seen on the examination of a pine cone, by the number of infertile seeds it contains. By comparing the amount of pollen produced by the apple with that produced by the pine, it will readily be seen that the wind is a very insignificant agent in the pollination of our orchards.

The notes as to the number of pollen grains were taken for about one square centimeter. As each apple blossom contains five pistils and each is only the fraction of a centimeter, wind pollination would be more accidental than otherwise.

G. O. GREENE,
Manhattan, Kan

Hybridization

Production of New Varieties by Cross Pollination

From our own experience and the experience of others, it would appear that if a good late keeping apple is desired, the chances are very slight that it will be produced from seeds of an early apple. On the other hand, seeds from a late keeping apple will not, necessarily, produce late keeping varieties. Apples have been so inter-crossed, in nature, for hundreds of years, that the characteristics of many varieties are apparent in the seedlings of one. It is possible that there never was a case where a seedling of a cultivated variety of apple was identical in every respect with its parent. If it is desired, then, to originate a new variety, the following methods are recommended as being the most likely to produce the variety with the characteristics sought for, although thousands of seedlings may have to be grown to attain this purpose:

1. To produce a hardy apple where no apples have yet been found hardy: Sow seeds of apples which have ripened in a climate as nearly similar as possible.

2. To produce a hardy long keeping apple of good quality: Sow seeds of long keeping apples of good quality which have ripened in a similar climate, and when possible have both parents long keeping varieties.

3. To produce an apple having certain characteristics, as regards hardiness, vigor and productiveness of tree, and quality, size and appearance of fruit: Sow seeds of varieties having most of the characteristics desired.

4. If seedlings are to be grown on a large scale, more varieties having the characteristics desired will probably be obtained if trees of several named sorts blossoming at the same time be planted in close proximity in the orchard, and the seeds used from fruit borne on these trees. The trees thus planted should combine all the good points in the standard aimed at, for the variety to be originated.

Apple seeds germinate best when sown in the autumn. If, however, it is not convenient to sow them at that time, they may be stratified; that is, mixed with sand, slightly moist, but not wet, and kept in a cool but dry place until spring. Seeds should not be sown in the autumn in soil which heaves much; better hold them over and sow them as early in the spring as the soil can be worked. If apple seeds become very dry they may not always germinate satisfactorily, and this should be guarded against. The seeds should be sown thinly, about two inches deep, in rows from two and one-half to three feet apart. Or, if the quantity is small, beds may be prepared and the seeds sown in rows about six inches apart. If sown in the autumn, most of them should germinate the following spring and make a growth of from one to two feet that season. They should be transplanted the following spring into rows from two and one-half to three feet apart, placing them 12 inches apart in the rows. The next spring they should be in good condition for planting in the seedling orchard.

Cross-bred and Hybrid Varieties

Those varieties which are originated by artificial cross-fertilization and hybridization are called cross-bred and hybrid, respectively. A hybrid is a cross between two species: as, for instance, between *Pyrus Malus*, the apple, or a variety of it, and *Pyrus baccata*, the Siberian crab. A cross-bred is a cross between two varieties of the same species, as, for instance, between the Northern Spy and McIntosh Red apples.

Although nearly all our best apples have been originated as seedlings, the reason is, not that good varieties cannot be produced by artificial cross-fertilization, but that comparatively little systematic work has been done in this direction in America until recent years. When one considers that a very large number of chance seedlings have been the result of natural cross-fertilization of the flowers of different varieties (for it is now an established fact that many

varieties of apples are self-sterile) it is reasonable to suppose that a much larger percentage of good apples will be obtained if the flowers are pollinated artificially, as then only the varieties which have the characteristics desired in the seedlings will be used as the parents, and, although it has been already said that apples have been so inter-crossed in nature for hundreds of years that there is no certainty what the seedlings of any variety will be like, yet the characteristics of the parents will be more likely to predominate than those of varieties whose blood has intermingled at a more remote period. Before beginning any work of this kind, it is important, then, to decide what kind of an apple is most desired, and to select as parents those varieties which have as many of the qualities sought for as possible. The seedlings raised will probably have more of the characteristics of the female parent than of the male, and this should be taken into consideration when selecting the variety for that purpose. There is, however, no certainty in the matter, and in originating cross-bred apples it is wise to do some crossing with one variety as the female parent, and some with the variety as the male parent. A hybrid, however, is almost certain to partake more of the female parent if the species differ widely.

The season when one may pollinate apple blossoms is very limited, as there is only from a week to 10 days during which the work may be done. In the blossom of the apple the organs of reproduction represent both sexes. When the pollen, which is the fine dust constituting the male part of the flower, comes in contact with the stigma, which is the upper part of the female organ, fertilization is liable to take place, and this must be prevented if artificial pollination is to be performed. The pollen which is contained in the anthers is shed almost as soon as the blossoms open, and work must begin, therefore, when the flower is in bud. There are usually five or six buds in a cluster on apple trees, but generally only the strong-

est of these set fruit. The more the flower bud is developed, the greater chances there will be that artificial pollination will be successful. The operator, however, must be certain that no pollen has already been shed. Two or three of the weakest and least developed buds are pinched off and the remainder are left to be operated upon, or, if some of the flowers are open, they are removed and the others left. A pair of small tweezers are very good for this purpose. They should be perfectly smooth at the tips, both outside and inside, so that no pollen will lodge there. The petals of the buds are now removed by means of the tweezers; the anthers which contain the pollen are then removed, by breaking the filaments off, and thrown away. In removing the petals and anthers, great care should be taken that the stigmas are not injured, as, if they are, failure is certain. Only the female part of the flower now remains. The stigmas are in condition to receive the pollen when they become moist. They will remain in this condition for a day or two. Pollen may, however, be applied to the stigmas before they are ready, as pollen will stay

in good condition longer than the stigmas. If the pollen is not applied immediately, the flowers which have been operated upon should be covered with a stout paper bag and the mouth tied tightly about the twig, so that no insect can get in. Flower clusters of the variety of apple which is to supply the pollen and be the male parent of the future seedlings, should be gathered just before the buds open, and the twigs put in water until the blossoms open and the pollen is shed, which can be easily detected as the anthers burst open, when the pollen becomes quite visible to the naked eye. If the flowers are taken in the orchard after they open there is every probability that insects may have deposited pollen from other varieties there, and thus the parentage of the cross-bred variety would not be certain. When the pollen and stigmas are ready, the bag is removed and the stigmas then well covered with the pollen. This may either be effected by holding the flower in the fingers and rubbing the anthers against the stigmas, by putting some of the pollen on the finger nail and thus rubbing it on, or by applying it on the end of a knife or some other flat sur-

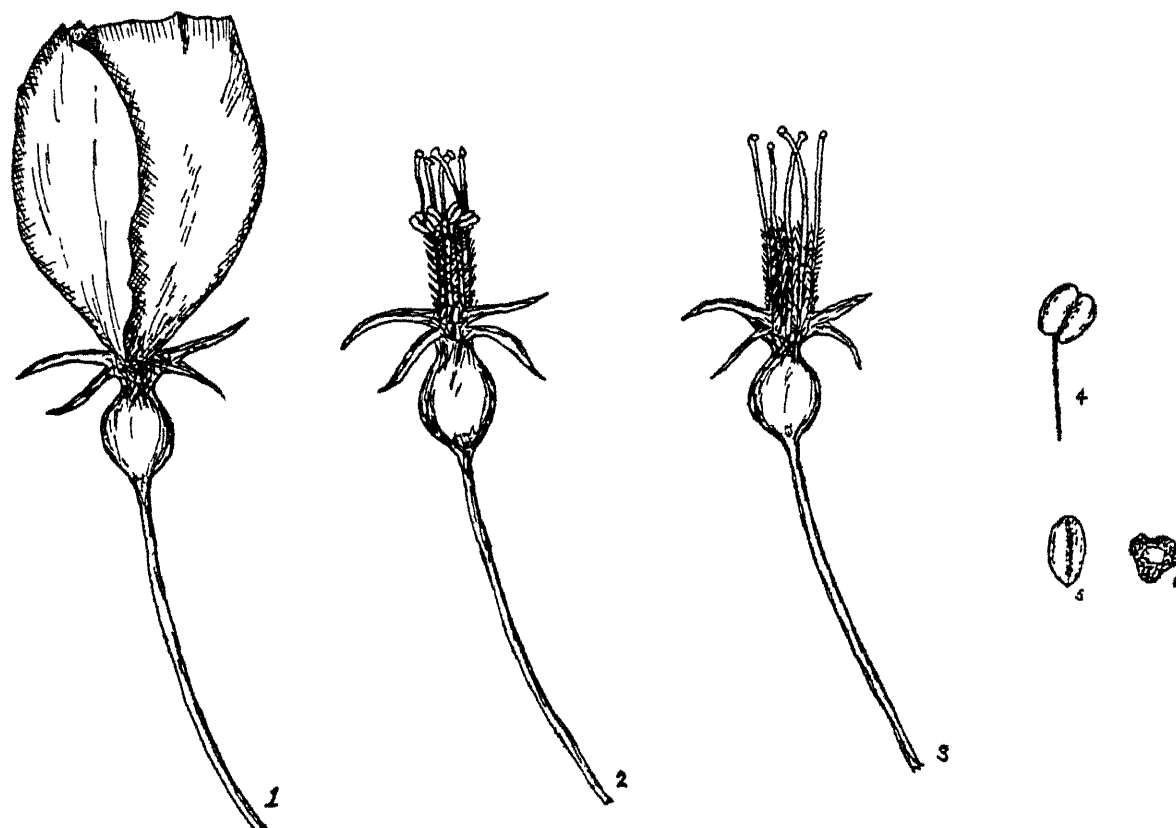

Flower of Apple Prepared for Cross-Fertilizing—1, flower just before opening; 2, the petals removed; 3, the anthers removed; 4, one of the anthers; 5 and 6, views of pollen highly magnified.

face. The camel's hairbrush, which is often recommended, is not a safe thing to use, as pollen may stick in the hairs, and if several kinds are worked with, there will be no certainty as to the parentage. After this operation has been performed the bag should be put on again and tied tightly as before. A label should then be attached to the twig, on which should be written a number, the names of the male and female parents, the number of flowers operated on, and the date on which the work was done. This record should also be kept in a notebook. When the blossoming period is over, and the fruit is well set the paper bag should be removed, a record taken of the number of apples which have set, and then a gauze or muslin bag tied over the fruit instead of the paper one. The apples should then be left to grow and ripen in the orchard. Late apples which are not thoroughly matured when harvested should be left as long as possible before the seeds are taken out. The seeds should be removed, however, in time to sow them before winter sets in. They should be counted and the number recorded with the other data, and then treated the same as has already been recommended in the paragraph on Seedling Varieties.

Much systematic work has been done in Canada in originating varieties of apples by cross-fertilization and hybridization. To the late Charles Arnold, of Paris, Ont., and to the late P. C. Dempsey, of Trenton, Ont., is due great credit for work done at a time when few were interested in the scientific aspects of fruit-growing. The Ontario apple, which was originated by Charles Arnold by crossing the Northern Spy with the Wagener, is a worthy memorial to that gentleman, it being one of our best and most profitable commercial apples. The Trenton and Walter apples are two of Mr. Dempsey's crosses, and are among the best apples of their season. The late horticulturist of the Central Experimental Farm, Mr. John Craig, also did some work in this direction, and some of his crosses which have fruited are promis-

ing. During the past eight years the writer has done some work also, the object being to obtain, if possible, hardy, late-keeping, productive apples of fine color and good quality, which are much needed in Northern and Eastern Ontario and the Province of Quebec. The McIntosh Red and Lawver apples were used for this work at first. They are good sized red apples, and also annual, though not heavy, bearers. The McIntosh Red apple is probably unsurpassed in quality by any apple of its season. The Lawver apple is the best keeping apple yet fruited at the Central Experimental Farm, it having been kept in good condition in an ordinary cellar for over a year. It was thought when these crosses were made that the Lawver would continue to prove hardy at Ottawa, but this variety was winter-killed in 1903-4.

Bud-Varieties, Sports

These are chance variations from the ordinary types which are sufficiently distinct to be regarded as different varieties. For instance, if the fruit on one branch of a tree which has not been grafted or budded is quite different from that on the others, it is a bud-variety. Bud-varieties may be propagated and perpetuated the same as other kinds.

Individuality in Apple Trees

Records are kept of the yields from each individual tree in the orchard at the Central Experimental Farm, Ottawa, hence it is known what each tree produces. It has been found that there is a marked variation in trees of the same age planted at the same time and growing under very similar conditions. It is now recognized by some of the best authorities that each bud of a tree has individual characteristics which separate it from all other buds and, although the differences in buds are, in most cases, so slight that it is impossible to detect them, yet in some instances they may be quite marked. Fruit growers have noticed that one tree or bush is more productive than another or bears larger, more highly colored or better flavored

fruit than other trees of the same variety, but few persons have recorded the yields from different trees, and little definite information has been published on the subject. From the records kept at the Central Experimental Farm, it is shown that some trees have yielded from two to four times as much as others. The following table gives the results ob-

tained. Scions have been taken from these trees and have been both top-grafted and root-grafted to learn if this individuality is perpetuated as it is important to learn if the tendency towards heavy or light bearing is continued when scions are taken from these trees and grafted.

W. T. MACOUN,
Central Experimental Farms, Ottawa.

APPLES—WEALTHY
(Planted, 1896)—Yielded in Gallons

Tree	1899	1900	1901	1902	1903	1904	1905	Total Yield 1899-1905
1.....	1.0	2.25	2.75	15.0	17.0	1.0	39.0
2.....	2.0	.5	2.5	12.0	14.0	8.0	39.0
3.....	1.75	12.0	2.25	8.0	6.5	7.0	37.5
4.....	9.0	2.25	15.5	20.5	27.0	1.0	28.0	103.25
5.....	7.5	6.5	7.75	23.0	7.5	23.0	13.0	88.25
6.....	3.25	6.5	3.5	24.0	17.5	5.0	59.75
7.....	7.5	1.0	10.0	19.0	16.0	19.0	72.5
8.....	8.5	.5	21.5	10.0	5.0	45.5
9.....	11.25	.25	27.5	21.0	20.0	80.0
10.....	1.0	12.25	30.0	17.5	8.0	68.75
11.....	1.25	11.25	21.5	31.0	10.0	75.0
12.....	7.5	18.5	2.0	13.5	13.5	55.0
13.....	4.25	6.25	4.5	20.0	.5	20.5	19.0	75.0
14.....	2.5	5.5	.5	34.0	17.0	8.0	67.5
15.....	2.25	3.5	21.5	8.5	31.5	16.0	83.25
16.....	3.0	2.25	4.0	22.5	4.5	16.5	23.5	76.25
17.....	2.0	1.0	22.5	8.5	16.0	50.0

APPLES—McMAHAN
(Planted, 1888)—Yielded in Gallons

Tree	1898	1899	1900	1901	1902	1903	1904	1905	Total Yield 1899-1905
1.....	62.0	83.0	2.0	147.0	1.5	141.0	40.0	476.5
2.....	42.0	1.0	6.0	12.5	98.0	23.0	116.0	30.0	328.5
3.....	32.0	29.0	49.0	18.0	55.0	63.5	56.0	108.0	410.5
4.....	35.0	34.5	4.0	63.0	34.0	67.0	69.0	306.5
5.....	37.5	55.0	49.0	61.0	98.0	300.5
6.....	29.0	4.5	46.0	.5	69.5	43.0	72.0	96.0	360.5
7.....	.5	9.5	19.5	4.0	19.0	39.5	14.0	37.0	143.0
8.....	7.0	9.0	27.0	9.0	53.0	15.5	54.0	35.5	210.0

APPLES—PATTEN'S GREENING
(Planted, 1892)—Yielded in Gallons

Tree	1898	1899	1900	1901	1902	1903	1904	1905	Total Yield 1899-1905
1.....	27.0	2.0	35.0	1.5	71.0	15.0	84.0	34.0	269.5
2.....	2.0	6.0	14.0	19.0	24.0	55.5	7.5	66.0	194.0
3.....	2.0	31.0	1.5	40.5	22.0	67.0	26.0	69.0	259.0
4.....	13.0	6.5	12.0	15.0	45.0	45.0	136.5
5.....	1.0	19.0	.5	17.5	21.0	54.0	75.0	188.0

Effect of Cross-Pollination on the Color of Apples

There has been some discussion in the past as to the effect of cross-pollination on the color of apples. Some have taken the ground that such crossing did effect the color of the variety crossed, others, that no such effect was produced and that, in the nature of the case, no effect could be looked for.

In order to ascertain the position of investigators at the present time on this point, some 50 letters were sent to heads of departments of horticulture in the various experiment stations in the country and to others whose knowledge or opportunity for observation would entitle them to an opinion. The majority of opinions thus far seems against the theory. All shades of opinion, however, are given.

"From my personal observation made in an orchard of from 100 to 200 trees I find that there is no immediate effect of pollination upon the color of the different varieties of fruit."

G. E. ADAMS,
Rhode Island State College.

"As far as color is concerned we find that, after working six years, very little change is produced directly by pollination. We have made no observations that lead us to believe that color was *directly* affected by pollination. Wherever we have detected any change in color it has been slight. The benefits of cross-pollination are, first, that you get a larger percentage of blossoms to set; second, that there are occasional changes in size and form."

C. I. LEWIS,
Oregon Experiment Station.

"I have never seen among fruit trees, except in a few instances, the color and form which I could believe had any evidence of being changed by cross-pollination. I think that, in a case where apples turn dark or striped, it is wholly the result of their having been crossed before, similar to bud sports, which, in fact, they are, in my opinion. The whole matter is in heredity, not from pollen."

LUTHER BURBANK,
Santa Rosa, Cal.

"Top grafting one variety of apples on another will not change the color of the fruit, nor will cross-pollination. The cross is not completed until the seeds have been planted and the new tree produced."

F. WALDEN,
Seattle, Wash.

"Speaking from the standpoint of a number of years of observation I do not believe that any definite effect of this kind (change in color) can be counted upon with certainty. One frequently finds examples of Greenings being apparently affected by the pollen of a Russet variety standing in somewhat close proximity, but I do not think you can count on these effects occurring with continuous regularity. They are to be regarded as occasional and somewhat sporadic. The influence of cross-pollination seems to be associated with affinities of varieties for each other."

JOHN CRAIG,
New York State Agricultural College

"Observations on cross-pollination of apples at this station do not furnish any evidence that the color of varieties is affected."

ALBERT DICKENS,
Kansas State Agricultural College.

"Insofar as our knowledge of plant breeding goes, the application, for example, of Arkansas Black pollen to Spitzenburg would have no effect on the color of the resulting apples. The pollen affects only the seeds."

JAMES G. MOORE,
University of Wisconsin College of Agriculture.

"I am inclined to think that there is not much basis for this theory (Effect of foreign pollen on the color of apples). The case is quite different from that of Xenia in corn, inasmuch as we are here concerned with the color of adnate parts of the seed rather than the color of the seed coat."

H. L. PRICE,
Virginia Experiment Station.

"I have made numerous cross-pollinations between various varieties of apples

resulting in several hundred good fruits. In none of these have I ever seen the slightest indication that the pollen from one variety affects the color of the variety upon which it is used."

R. A. EMERSON,
University of Nebraska, Dept. of Horticulture.

"I am of the opinion that there is no reason why such a variation (change of color) should follow on the surface of the fruit by the cross-pollination."

FABIAN GARCIA,
New Mexico College of Agricultural and Mechanical Arts.

"In recent years we have done considerable cross-breeding of apples here at the experiment station for the purpose of securing new varieties. We have never found that the pollen used to fertilize a given variety in any way modified the color of that variety. For instance, we have used Jonathan quite largely in our crosses and have crossed it with a goodly number of varieties, some of which are pure yellow. We have never found that a Jonathan fertilized with a yellow apple pollen was any paler in color than when fertilized by a bright red apple like the King David."

J. C. WHITTIN,
University of Missouri, Columbia, Mo.

"I am of the opinion that no change of color will result from crossing apples of different colors."

H. S. BRODE,
Whitman College, Dept. of Biology.

"So far as my observation goes and also from the standpoint of the botany of the fruit, I have grave doubts if there is any direct influence of the pollen of one variety on the color of the fruit of another variety."

E. P. BENNETT,
The Colorado Agricultural Experiment Station.

"In my opinion the cross-fertilizations of apples has no appreciable effect on the color of the fruit. I realize that some horticulturists differ in regard to this. In fact it is difficult to find any two horticulturists who will agree as to the effect of the cross-pollenization. It

is difficult to understand how it can affect the coloring of the apples or the quality of the fruit, *i. e.*, looking at it from a standpoint of a plant breeder."

J. N. ALDERMAN,
West Virginia University.

"As to the matter of theory regarding the pollen of one variety of fruit affecting the color of another variety, I have never tested it out by scientific experiment but I have been observing fruits for many years that had every opportunity to be as affected and have never seen anything that leads me to believe that there is such influence. The skin of each variety seems to have its characteristic color regardless of others that grow near it."

H. E. VAN DEMAN.

"All of my experience, in crossing plants of different kinds, would lead me to believe that there would be very little if any effect shown on the color of fruit that received pollen from some other variety."

E. J. KYLE,
Agricultural and Mechanical College of Texas.

"I see no reason why cross-pollination should have any effect upon the color of the fruit. The edible portion of the apple and the skin are derived from the calyx and receptacle and not from any portion of the plant which comes from the fertilized egg, consequently there could be no direct effect as the result of a cross-fertilization."

GEORGE M. REED,
University of Missouri.

"I regret that I have no experimental data upon the subject proposed in your letter of December 1st. There is a firm horticultural conviction that there may be a modification of the current growth of fruit while a cross-pollenized seed is maturing. I am of the opinion that this conviction is warranted by observation, but I cannot cite specific demonstration thereof."

E. J. WICKSON,
University of California.

"We have for three years been carrying on apple breeding experiments at this station, the object being to secure an apple better adapted to Idaho conditions than now existing varieties. In the spring of 1910 we made approximately 5,000 crosses. From this work we got a little better than 2,000 apples. The varieties that we are using are Ben Davis, Spitzenburg, Wagener, Jonathan and Winesap. In the fall of 1910 I noticed a variation in size, flavor and color. The color factor was the most interesting one to me. As a rule the female parent characters were exceedingly strong. By placing the apple from certain parents together, such as Jonathan and Ben Davis, and comparing this bunch of apples with the apples secured by a Spitzenburg and Ben Davis cross, I noticed a very superior color on the latter crop. In other words, when the Spitzenburg was used as a male the crosses all showed the Ben Davis characters in form, size and texture of flesh, but much more highly colored than the crosses where the Ben Davis was used as a male and the above named variety used as a female. These conditions were not so noticeable among our crosses of 1911 but were slightly showing. We do not have sufficient proof at the present time to say that such conditions will always exist but I am inclined to think that the color character will respond to environmental influence more quickly than any others.*"

W. H. WICKS,

University of Idaho, College of Agriculture.

"In all of my long years of experience in hand pollinating apple blossoms in connection with apple breeding work, I have rarely seen any change in color or form which could be attributed only to the immediate influence of the pollen. There came to my notice some years ago, an apple on which two-fifths was the color of the Pewaukee. The apple was produced on a Pewaukee tree in

* Observation on the 1912 crop convinced Professor Wicks that there was nothing in the theory and that the supposed effects on the 1911 crop were due to environmental causes.—Ed.

which the branches interlaced with those of an adjacent Wealthy tree. The effect of the immediate influence of pollen was so clear and unmistakable that I had the apple modeled in wax. The model is now in the museum at the State Experiment Station at Geneva, N. Y."

S. H. BEACH,

Iowa State College and Experiment Station

"There is good reason to believe that the source of pollen might, to a very limited extent, modify the size of the fruit produced and, in some rare cases, the color to a slight extent."

O. M. MORRIS,

State College of Washington

"In my own experience I do not remember any instance that attracted my attention save occasional specimens of apples seen bearing, say, a sharply defined longitudinal band of red on a yellowish apple, the band covering one-fifth, two-fifths or three-fifths of the apple. The only explanation I have ever seen of this is that the apple, having five stigmas, in this case, one, two or three stigmas had been pollinated with pollen from a red variety, but this, I think, is merely a theoretical explanation."

E. WALKER,

College of Agriculture, Fayetteville, Ark

SELF-FERTILE AND SELF-STERILE FRUITS

Some varieties of fruits are more or less completely unable to pollinate themselves, and they should be planted near other varieties to insure fruitfulness. Any variety will fertilize any other variety of the same species, so far as known, if the bloom occurs at the same time. In general, in planting a self-sterile variety, every second or third row should be planted to some other variety. The subject is little understood, but the following lists represent the best of our knowledge.

Pears (Waite)

Varieties more or less self-sterile.—Anjou, Bartlett, Boussock, Clairgeau, Clapp, Columbia, De la Chene, Doyenne

Steuille, Easter, Gansels Bergamotte, Gray Doyenne, Howell, Jones, Lawrence, Louise Bonne, Mount Vernon, Pound, Sheldon, Souvenir du Congress, Superfin, Colonel Wilder, Winter Nelis.

Varieties generally self-fertile—Angouleme, Bosc, Brockworth, Buffman, Diel, Doyenne d'Alencon, Flemish Beauty, Heathcote, Kieffer, Le Conte, Manning Elizabeth, Seckel, Tyson, White Doyenne

Apples (Waite and Fairchild)

Varieties more or less self-sterile—Bellflower, Chenango (Strawberry), Gravenstein, King, Northern Spy, Norton, Melon, Primate, Rambo, Red Astrachan, Roxbury Russet, Spitzenburg, Tolman Sweet.

Varieties mostly self-fertile.—Baldwin, Codling, Greening.

“The varieties of apples are more inclined to be sterile to their own pollen than the pears. With the former, in the great majority of cases, no fruit resulted from self-pollination. The results, as a rule, however, were less clear-cut than in the pear, because, with most of the self-sterile varieties, an occasional fruit will set under self-pollination, and none of the varieties were very completely self-fertile”—Waite

Other Fruits

The quince seems to fruit nearly as well with its own pollen as with that of another variety”—Waite.

Many of the native plums are notoriously self-sterile, particularly Wild Goose. Other self-sterile varieties are Miner, Wazata, Minnetonka, Itaska. Varieties more or less self-fertile are Moreman, Newman, Wayland, Golden Beauty, Marianna, Deep Creek, Purple Yosemite.

Strawberries often lack stamens altogether, whilst others, like Crescent, have so few and so poor stamens that they are practically self-sterile. Ordinarily, there should be a row of a perfect-flowered variety for every two rows of a pistillate or infertile variety.

Grapes (Beach)

Unfruitful when planted by themselves.—Black Eagle, Brighton, Eumelan, Massasoit, Wilder, Rogers' No. 5, Gaertner, Merrimac, Requa, Ammia, Essex, Barry, Herbert, Salem.

Able to set fruit of themselves.—Concord, Diamond, Niagara, Winchell or Green Mountain, Rogers' Nos. 13, 24, and 32, Agwam, Delaware.

(Bailey's Rule Book, pages 121, 122)

Normal Bloom Chart

APPLES	No. of Observations	APRIL								MAY				
		23	24	25	26	27	28	29	30	1	2	3	4	5
May	9	*	*	*	*	*	*	*	*	*
Benoni	8	..	*	*	*	*	*	*	*	*
Peach Pond	9	..	*	*	*	*	*	*	*	*
Stevenson	10	..	*	*	*	*	*	*	*	*
Early Ripe	10	..	*	*	*	*	*	*	*	*
Fanny	8	..	*	*	*	*	*	*	*	*
Gideon	10	..	*	*	*	*	*	*	*	*
Oldenburg	10	..	*	*	*	*	*	*	*	*
Seedless	3	..	*	*	*	*	*	*	*	*	*	*	*	..
Early Harvest	9	*	*	*	*	*	*	*
Red Astrachan	9	*	*	*	*	*	*	*
Smith Cider	9	*	*	*	*	*	*	*
Arkansas	10	*	*	*	*	*	*	*
Bentley	10	*	*	*	*	*	*	*
Gravenstein	10	*	*	*	*	*	*	*
Jonathan	5	*	*	*	*	*	*	*
Stump	10	*	*	*	*	*	*	*
Ridge	9	*	*	*	*	*	*	*
Smokehouse	9	*	*	*	*	*	*	*
Keswick	9	*	*	*	*	*	*	*
Red June	9	*	*	*	*	*	*
Pilot	2	*	*	*	*	*	*
Colton	6	*	*	*	*	*	*
Capp	5	*	*	*	*	*	*
Berry Red	9	*	*	*	*	*	*
Summer Pearmain	8	*	*	*	*	*	*
Buckingham	8	*	*	*	*	*	*
Bullock	6	*	*	*	*	*	*
Cannon	9	*	*	*	*	*	*
Crop	7	*	*	*	*	*	*
Horse	10	*	*	*	*	*	*
Ivanhoe	8	*	*	*	*	*	*
Sharp	8	*	*	*	*	*	*
Bough	0	*	*	*	*	*	*
Yellow Bellflower..	10	*	*	*	*	*	*
Late Strawberry..	4	*	*	*	*	*	*
Milam	5	*	*	*	*	*	*
Nero	9	*	*	*	*	*	*
Yellow Transparent	9	*	*	*	*	*	*
Primate	8	*	*	*	*	*	*
Stark	9	*	*	*	*	*	*
Alexander	9	*	*	*	*	*	*
Baldwin	7	*	*	*	*	*	*
Boskoop	8	*	*	*	*	*	*
Chenango	10	*	*	*	*	*	*
Esopus	10	*	*	*	*	*	*
Eureka	8	*	*	*	*	*	*
Fameuse	9	*	*	*	*	*	*
Gano	10	*	*	*	*	*	*
Jersey Sweet	10	*	*	*	*	*	*
Missouri	9	*	*	*	*	*	*
Nickajack	9	*	*	*	*	*	*
Peck	10	*	*	*	*	*	*
Pewaukee	9	*	*	*	*	*	*
Plumb	10	*	*	*	*	*	*
Shockley	9	*	*	*	*	*	*
Swaar	10	*	*	*	*	*	*
Tetofski	8	*	*	*	*	*	*
Via	7	*	*	*	*	*	*
Washington	10	*	*	*	*	*	*
Willow	10	*	*	*	*	*	*
Wolf River	9	*	*	*	*	*	*
Yates	10	*	*	*	*	*	*
York	9	*	*	*	*	*	*
Bryant	9	*	*	*	*	*	*
Fall Orange	10	*	*	*	*	*	*
Fall Pippin	10	*	*	*	*	*	*
Jumbo	9	*	*	*	*	*	*
Lankford	9	*	*	*	*	*	*
St. Win. Pearmain.	9	*	*	*	*	*	*

Normal Bloom Chart—Continued

APPLES	No. of Observations	APRIL				MAY											
		27	28	29	30	1	2	3	4	5	6	7	8	9	10	11	12
Limber Twig	10	*	*	*	*	*	*	*	*	*	*	*	*	*	*	*	*
Loy	9	*	*	*	*	*	*	*	*	*	*	*	*	*	*	*	*
Maiden Blush	10	*	*	*	*	*	*	*	*	*	*	*	*	*	*	*	*
Nash	10	*	*	*	*	*	*	*	*	*	*	*	*	*	*	*	*
Rebel	9	*	*	*	*	*	*	*	*	*	*	*	*	*	*	*	*
Robertson White	6	*	*	*	*	*	*	*	*	*	*	*	*	*	*	*	*
Summer Rose	10	*	*	*	*	*	*	*	*	*	*	*	*	*	*	*	*
Williams	10	*	*	*	*	*	*	*	*	*	*	*	*	*	*	*	*
Stewart	8	*	*	*	*	*	*	*	*	*	*	*	*	*	*	*	*
Baltzley	9	*	*	*	*	*	*	*	*	*	*	*	*	*	*	*	*
Albemarle	8	*	*	*	*	*	*	*	*	*	*	*	*	*	*	*	*
Arkansas Beauty	10	*	*	*	*	*	*	*	*	*	*	*	*	*	*	*	*
Bonum	9	*	*	*	*	*	*	*	*	*	*	*	*	*	*	*	*
Coffelt	6	*	*	*	*	*	*	*	*	*	*	*	*	*	*	*	*
Lawver	8	*	*	*	*	*	*	*	*	*	*	*	*	*	*	*	*
Grimes	10	*	*	*	*	*	*	*	*	*	*	*	*	*	*	*	*
Hubbardston	10	*	*	*	*	*	*	*	*	*	*	*	*	*	*	*	*
Roger's Sweet	5	*	*	*	*	*	*	*	*	*	*	*	*	*	*	*	*
Royal Red	8	*	*	*	*	*	*	*	*	*	*	*	*	*	*	*	*
Vanderspiegel	7	*	*	*	*	*	*	*	*	*	*	*	*	*	*	*	*
Wealthy	10	*	*	*	*	*	*	*	*	*	*	*	*	*	*	*	*
White Pippin	10	*	*	*	*	*	*	*	*	*	*	*	*	*	*	*	*
Arkansas Black	5	*	*	*	*	*	*	*	*	*	*	*	*	*	*	*	*
Cumberland	5	*	*	*	*	*	*	*	*	*	*	*	*	*	*	*	*
Jefferis	10	*	*	*	*	*	*	*	*	*	*	*	*	*	*	*	*
Sops-of-Wine	9	*	*	*	*	*	*	*	*	*	*	*	*	*	*	*	*
Wagener	9	*	*	*	*	*	*	*	*	*	*	*	*	*	*	*	*
Mann	7	*	*	*	*	*	*	*	*	*	*	*	*	*	*	*	*
Beauty of Kent	9	*	*	*	*	*	*	*	*	*	*	*	*	*	*	*	*
Ben Davis	10	*	*	*	*	*	*	*	*	*	*	*	*	*	*	*	*
Chattahoochee	3	*	*	*	*	*	*	*	*	*	*	*	*	*	*	*	*
Tompkins King	9	*	*	*	*	*	*	*	*	*	*	*	*	*	*	*	*
R. I. Greening	9	*	*	*	*	*	*	*	*	*	*	*	*	*	*	*	*
Winesap	10	*	*	*	*	*	*	*	*	*	*	*	*	*	*	*	*
Mason Stranger	10	*	*	*	*	*	*	*	*	*	*	*	*	*	*	*	*
Newtown Pippin	8	*	*	*	*	*	*	*	*	*	*	*	*	*	*	*	*
Ortley	10	*	*	*	*	*	*	*	*	*	*	*	*	*	*	*	*
Roxbury	9	*	*	*	*	*	*	*	*	*	*	*	*	*	*	*	*
Sadie Sweet	3	*	*	*	*	*	*	*	*	*	*	*	*	*	*	*	*
Tewksbury	9	*	*	*	*	*	*	*	*	*	*	*	*	*	*	*	*
Virginia Beauty	6	*	*	*	*	*	*	*	*	*	*	*	*	*	*	*	*
Arkansas Red	2	*	*	*	*	*	*	*	*	*	*	*	*	*	*	*	*
World Wonder	3	*	*	*	*	*	*	*	*	*	*	*	*	*	*	*	*
Mt. Boomer	9	*	*	*	*	*	*	*	*	*	*	*	*	*	*	*	*
Tolman	9	*	*	*	*	*	*	*	*	*	*	*	*	*	*	*	*
Rome	9	*	*	*	*	*	*	*	*	*	*	*	*	*	*	*	*
Walbridge	8	*	*	*	*	*	*	*	*	*	*	*	*	*	*	*	*
Porter	8	*	*	*	*	*	*	*	*	*	*	*	*	*	*	*	*
Wythe	3	*	*	*	*	*	*	*	*	*	*	*	*	*	*	*	*
Northern Spv	3	*	*	*	*	*	*	*	*	*	*	*	*	*	*	*	*
Moore Seedling	3	*	*	*	*	*	*	*	*	*	*	*	*	*	*	*	*
Mother	9	*	*	*	*	*	*	*	*	*	*	*	*	*	*	*	*
Richland	2	*	*	*	*	*	*	*	*	*	*	*	*	*	*	*	*
Ralls	7	*	*	*	*	*	*	*	*	*	*	*	*	*	*	*	*

CRAB APPLES	No. of Observations	APRIL									MAY						
		21	22	23	24	25	26	27	28	29	30	1	2	3	4	5	6
Lake Yellow	8	*	*	*	*	*	*	*	*	*	*	*	*	*	*	*	*
Transcendant	11	*	*	*	*	*	*	*	*	*	*	*	*	*	*	*	*
Hyslop	12	*	*	*	*	*	*	*	*	*	*	*	*	*	*	*	*
Maiden Blush	13	*	*	*	*	*	*	*	*	*	*	*	*	*	*	*	*
Elgin	9	*	*	*	*	*	*	*	*	*	*	*	*	*	*	*	*
English	9	*	*	*	*	*	*	*	*	*	*	*	*	*	*	*	*
Quaker Beauty	11	*	*	*	*	*	*	*	*	*	*	*	*	*	*	*	*
Queen	8	*	*	*	*	*	*	*	*	*	*	*	*	*	*	*	*
Red Siberian	11	*	*	*	*	*	*	*	*	*	*	*	*	*	*	*	*
Whitney	10	*	*	*	*	*	*	*	*	*	*	*	*	*	*	*	*
Blushing Maid	8	*	*	*	*	*	*	*	*	*	*	*	*	*	*	*	*
Montreal Beauty	10	*	*	*	*	*	*	*	*	*	*	*	*	*	*	*	*
Soulard	10	*	*	*	*	*	*	*	*	*	*	*	*	*	*	*	*

The dates above given were worked out by the Virginia Experiment Station and will, of course, vary with the locality, but the bloom period of the varieties given would be in the same relation to each other.—Ed.

VARIETIES OF APPLES

Explanations

<i>A</i>	autumn	<i>G</i>	good	<i>S</i>	summer
<i>a</i>	early autumn	<i>g</i>	green	<i>s</i>	small
<i>a</i>	late autumn	<i>k</i>	kitchen	<i>s</i>	striped or splashed
<i>B</i>	best	<i>L</i>	large	<i>V</i>	very
<i>b</i>	both family and market	<i>M</i>	medium	<i>VG</i>	very good
<i>b</i>	both kitchen and market	<i>m</i>	market	<i>W</i>	winter
<i>C</i>	cider	<i>o</i>	orange	<i>W</i>	early winter
<i>c</i>	conical	<i>ob</i>	oblate	<i>w</i>	late winter
<i>dr</i>	dark red	<i>pip.</i>	pippin	<i>wi</i>	white
<i>e</i>	early summer	<i>r</i>	red	<i>y</i>	yellow
<i>f</i>	family	<i>r</i>	roundish		
<i>fl</i>	flat	<i>ru</i>	russet		

The asterisk (*) indicates the rating for cultivation in the northern, central and southern divisions of the United States, as given by the American Pomological Society, the numerals of the last three columns representing the number of commendatory stars given to each variety on the basis of one star (or, very meritorious, two stars) for a state. Those marked ° are commended for trial. The numerals after certain of the varieties refer to the popular synonyms, given below the table.

Names	Size	Form	Color	Qual-ity	Use	Season	N. Div.	C. Div.	S. Div.
Akin.....	L	rc	rs	<i>G</i>	<i>b</i>	<i>W</i>			
Alexander.....	L	rc	<i>rs</i>	<i>G</i>	<i>b</i>	<i>a</i>	11*	10*	4*
American Beauty.....	L	rob	<i>yr</i>	<i>VG</i>	<i>b</i>	<i>W</i>	2*	2*	
American Golden (Pip.).....	L	rob	<i>gy</i>	<i>VG</i>	<i>b</i>	<i>W</i>	3*	1*	
Arkansas.....	L	rc	<i>yr</i>	<i>VG</i>	<i>b</i>	<i>W</i>	2*	2*	
Arnold's Beauty.....	M	fl	<i>yr</i>	<i>VG</i>	<i>f</i>	<i>W</i>	2*		
Aromatic Carolina.....	L	fl	<i>yr</i>	<i>VG</i>	<i>f</i>	<i>A</i>			2*
Arctic.....	L	rc	<i>yr</i>	<i>G</i>	<i>b</i>	<i>W</i>			
Autumn Bough.....	M	rc	<i>gy</i>	<i>VG</i>	<i>f</i>	<i>a</i>	3*	4*	
Autumn Swaar.....	M	rob	<i>gy</i>	<i>VG</i>	<i>f</i>	<i>a</i>	1*	5*	1*
Babbitt.....	M	r	<i>r</i>	<i>G</i>	<i>f</i>	<i>W</i>			
Bailey Sweet.....	L	rc	<i>rs</i>	<i>VG</i>	<i>b</i>	<i>a</i>	5*	7*	1*
Baker.....	L	rob	<i>yr</i>	<i>VG</i>	<i>b</i>	<i>W</i>	2*	1*	
Baldwin.....	L	rc	<i>rg</i>	<i>VG</i>	<i>b</i>	<i>W</i>	21*	11*	2*
Baltimore.....	M	rc	<i>ry</i>	<i>VG</i>	<i>b</i>	<i>W</i>	2*	1*	
Baltzby.....	L	rob	<i>y</i>	<i>G</i>	<i>b</i>	<i>A</i>		1*	
Banana (Winter B.).....	M	rc	<i>y</i>	<i>B</i>	<i>b</i>	<i>W</i>	2*	1*	1*
Beach.....	L	ob	<i>r</i>	<i>VG</i>	<i>b</i>	<i>W</i>			
Beauty of Kent.....	L	rc	<i>rs</i>	<i>G</i>	<i>b</i>	<i>a</i>	6*	1*	2*
Belden Sweet.....	M	rc	<i>y</i>	<i>G</i>	<i>f</i>	<i>W</i>	1*		
Belmont.....	L	rc	<i>yr</i>	<i>B</i>	<i>b</i>	<i>W</i>	6*	7*	2*
Ben Davis (N. Y. Pip.).....	L	rc	<i>yr</i>	<i>G</i>	<i>b</i>	<i>W</i>	5*	30*	12*
Benoni.....	M	rob	<i>yr</i>	<i>VG</i>	<i>b</i>	<i>S</i>	10*	16*	2*
Bentley's Sweet.....	M	rob	<i>gy</i>	<i>VG</i>	<i>b</i>	<i>W</i>		2*	1*
Berkshire Spy.....	M	rc	<i>rs</i>	<i>VG</i>	<i>f</i>	<i>W</i>	1*		
Bethlehemmite.....	L	rob	<i>yr</i>	<i>B</i>	<i>b</i>	<i>W</i>	1°	1*	1*
Bevan (B.'s Favorite).....	M	flc	<i>yr</i>	<i>G</i>	<i>f</i>	<i>S</i>			3*
Bietigheimer (Red B.).....	L	flc	<i>gr</i>	<i>G</i>	<i>m</i>	<i>a</i>			
Black (Jersey).....	M	fl	<i>dr</i>	<i>G</i>	<i>f</i>	<i>W</i>		4*	1*
Bledsoe.....	L	r	<i>s</i>	<i>G</i>	<i>b</i>	<i>a</i>			
Blenheim (Pippin).....	L	rob	<i>yr</i>	<i>VG</i>	<i>b</i>	<i>W</i>	7*	1*	
Blue Pearmain.....	L	rc	<i>r</i>	<i>G</i>	<i>m</i>	<i>W</i>	8*	2*	
Bogdanoff.....	M	ob	<i>ry</i>	<i>G</i>	<i>b</i>	<i>W</i>			
Bonum.....	L	rob	<i>yr</i>	<i>VG</i>	<i>m</i>	<i>a</i>	1*	9*	5*
Borovinka.....	M	rob	<i>yr</i> <i>s</i>	<i>G</i>	<i>m</i>	<i>a</i>			
Bough.....	L	ob	<i>gy</i>	<i>VG</i>	<i>b</i>	<i>S</i>			
Bourassa.....	M	rc	<i>yr</i>	<i>G</i>	<i>m</i>	<i>a</i>	1*		
Bowen (Favorite).....	M	rob	<i>r</i>	<i>G</i>	<i>m</i>	<i>A</i>	1°		

Varieties of Apples—Continued.

Names	Size	Form	Color	Qual-ity	Use	Season	N. Div.	C. Div.	S. Div.
Bower's Nonpareil..	L	fl	yr	VG	b	W		1*	
Bowling's Sweet.	M	r	yr	G	m	a		1*	
Brittle Sweet ..	M	rc	rs	VG	f	a	2*		
Broadwell...	M	rc	gy	VG	b	a	4*	7*	
Brown.....	L	fl	rs	VG	b	a	1*	1*	
Bruce's Summer	L					S			5*
Bryan, Mrs. B.	L	c	ob	VG	b	a			
Buckingham (2)	L	rob	yr	VG	b	W	1*	12*	12*
Buff.....	L	rob	yr	G	f	W		1*	4*
Buffington.....	M	fl	y	G	f	S	1*	2*	2*
Bullock's Pippin (3).....	S	rc	yr	B	b	W	4*	12*	
Buncombe.....	M	rob	yr	G	b	W		4*	9*
Burlington (Pippin)...	M	flc	yr	VG	b	W	1*		
Cadwallader (Golden)...	M	rob	y	G	b	W		1*	
Calef Sweet.....	L	rob	y	VG		W	1*		
Calkins (C.'s Pippin)	L	rc	yr	G	b	W	1*		
Camack Sweet.....	M	rob	y	G	b	W		1*	4*
Camfield.....	M	rob	gr	G	b	W	2*	5*	
Canada Baldwin...	M	ob	r	VG		W	1*		
Canada Reinette ..	L	rc	gy	VG	b	W	7*	2*	1*
Cane Creek Sweet.	M	r	y	G	f	S			3*
Cannon Pearmain	M	rc	rs	VG	f	W		7*	2*
Carolina Beauty.	M	rob	dr	G	b	W			
Carolina Watson...	M	flc	gyr	G	m	S			6*
Carlough.....	L	rc	gy	G	m	W			
Carter's Blue...	L	rob	gr	VG	b	a		2*	11*
Celestia.....	L	ve	gy	VG	b				
Champlain (Nyack).....	M	rob	yr	G	b	a			
Chattahoochee.....	M	fl	y	G	m	W			3*
Chenango (S'berry).....	M	obc	gr	VG	b	a	6*	10*	2*
Clark Pearmain...	M	rob	y	VG	m	W		2*	3*
Clayton.....	L	c	yr	G	b	W		3*	
Clyde (Beauty).....	L	rc	gr	G	b	W	2*	2*	
Cogswell.....	M	rob	yr	B	b	W	5*	2*	2*
Cole's Quince.....	L	rob	gr	VG	b	W	3*	4*	1*
Collins.....	M	r	s	VG	m	W			
Colton (Ea. C.).....	M	r	y	VG	b	S			
Colvert.....	L	rob	yr	G	b	a	3*	2*	
Cooper.....	L	rob	gr	G	m	a	1*	9*	
Cooper Early.....	M	r	y	G	m	A	1*	4*	1*
Cooper Market.....	M	rc	yr	G	m	W	2*	2*	
Cornell.....	M	ob	yr	G	b	a	2*	6*	2*
Cox's Orange (Pippin)...	M	ob	yr	VG	f	a	1*		
Cracking.....	L	rob	y	G	k	a		2*	2*
Creek.....	M	flc	yr	VG	b	W		1*	
Cross.....	L	rob	rs	VG	b	S		1*	
Cullasaga.....	M	rc	ys	G	m	W		2*	7*
Curtis' Sweet.....	L	rc	yr	G	k	a	1*		
Danvers' Sweet	M	rob	gy	VG	b	W	4*	6*	
Delicious.....	L	obc	yr	B	b	W			
Detroit Red.....	M	rob	r	G	b	W	1*	2*	
Disharoon.....	M	rc	g	G	b	A			5*
Dominie.....	M	rob	gr	VG	b	W	2*	14*	1*
Drap d'Or.....	L	rob	y	VG	f	S	2*	5*	2*
Dutch Mignonne.....	M	rob	rs	G	m	W	5*	2*	1*
Dyer (35).....	M	r	gy	VG	f	a	9*	9*	4*
Early Harvest.....	M	rob	gy	VG	b	S	16*	25*	15*
Early Joe.....	S	fl	yr	B	f	S	5*	11*	3*
Early Margaret	M	r	rs	VG	b	S	1*	12*	9*
Early Pennock..	L	rc	g	G	m	S	2*	10*	2*

Varieties of Apples—Continued.

Names	Size	Form	Color	Quality	Use	Season	N. Div.	C. Div.	S. Div.
Early Ripe.....	M	rob	y	G	f	S	4*	2*
Early Strawberry (4).....	S	r	rs	VG	f	S	8*	11*	5*
Edgar Red Streak.....	L	rob	rs	VG	f	W	2+	2*
English Russet.....	re	yru	VG	b	W	7*	5*	1*
Esopus Spitzenburg.....	L	ob	yr	B	b	W	8*	8*	1*
Etowah.....	M	obe	yr	G	W	2*
Eustis.....	M	rob	rs	VG	f	W	2*
Evening Party.....	M	fl	r	VG	b	W	2*	3*
Ewalt.....	L	r	yr	G	m	W	1*	3*
Excel.....	L	obe	yr	VG	b	W
Fallwater (5).....	L	re	gy	G	m	W	3*	15*	1*
Fall Harvey.....	L	rob	gy	G	m	a	2*	2*	2*
Fall Jenneiting.....	L	fl	gy	G	m	a	3*	3*	2*
Fall Orange.....	L	r	yr	G	b	a	4*	6*	2*
Fall Pippin.....	L	rob	gy	VG	b	a	12*	19*	4*
Fall Queen (Haas).....	M	obe	yr	G	b	A	4*	4*	2*
Fall Wine.....	M	rob	ry	B	f	a	4*	12*	2*
Fameuse (6).....	M	rob	rs	VG	b	W	18*	17*	1*
Family.....	M	flc	yr	VG	m	S	8*
Fanny.....	M	fl	rs	VG	b	S	1*	3*
Faust Winter.....	M	r	yr	G	W	3*
Ferdinand.....	L	fl	y	G	W	4*
Ferris.....	M	rfl	yr	G	b	W	1*
Fink.....	M	fl	yr	G	m	w	3*
Foundling.....	M	rob	yr	G	f	A	6*
Fourth of July.....	M	rob	rs	G	m	S	3°	2*	2*
Fulton.....	M	fl	gy	G	m	W	1*	6*
Gabriel.....	M	rob	ry	G	m	a	2*	1*
Gano (Payton).....	L	rob	yr	G	m	W
Garden Royal.....	M	rob	yr	B	f	S	6*	2*
Garretson.....	M	re	y	G	k	A	1*	1*	3*
Gilpin (7).....	S	re	yr	G	m	W	2*	16*	3*
Golden Ball.....	L	r	y	G	f	a	1*
Golden Russet.....	M	rob	yru	VG	b	W	13*	7*	1*
Golden Sweet.....	L	r	gy	VG	b	S	12*	13*	4*
Granite Beauty.....	L	rob	yr	G	b	W	2*
Gravenstein.....	L	rob	yr	VG	b	a	20*	16*	7*
Green Cheese.....	M	fl	gy	VG	b	W	7*	6*
Green Newtown.....	M	rob	gy	VG	b	W
Green Sweet.....	M	rob	gy	G	b	W	3*	2*
Grimes' Golden.....	M	rob	gy	VG	f	W	3*	20*	2*
Haas Fall Queen.....	M	obe	yr	G	b	A
Hall.....	S	fl	yr	VG	f	W	11*	7*	3*
Hamilton.....	L	r	yr	G	b	A	1*
Hartford Sweet.....	L	rob	rs	G	m	W	3*	1*
Haskell Sweet.....	M	fl	gy	VG	f	a	3*
Hawthornden.....	M	rob	gy	G	b	a	5*	6*	1*
Hewes' Crab.....	S	r	yr	G	C	a	15*	4*
Hibernal.....	M	obe	rs	G	b	A
Higby Sweet.....	M	re	yr	VG	f	a	1°	1*
High Top Sweet (8).....	S	r	gy	VG	b	S	6*	10*	2*
Hockett's Sweet.....	M	rob	yr	G	k	W	6*
Holland Pippin.....	L	r	gy	G	b	a	3*	4*	2*
Hoover (Bl'k Coal).....	M	r	yr	VG	b	W	1*	9*
Horn.....	M	fl	gr	VG	b	w	3*	6*
Horse (Haas).....	L	r	yr	G	b	S	1*	6*	13*
Hubbardston (H.'s Nonsuch).....	L	re	yr	VG	b	W	18*	12*
Hunt Russet.....	M	rob	yru	VG	b	W	4*	2*
Huntsman's Favorite.....	L	ob	y	VG	b	W	4*
Hurlbut.....	M	rob	yr	G	b	a	6*	2*

Varieties of Apples—Continued.

Names	Size	Form	Color	Qual-ity	Use	Season	N. Div.	C. Div.	S. Div.
Ingraham (I. Seedling).....	M	obc	rs	VG	b	W			
Iowa Blush								2*	
Irish Pippin	M	r	rs	VG	b	W	1*	1*	
Isham (I. Sweet).....	L	rob	r	G	k	W			
Jefferis.....	M	rob	yr	VG	b	a	3*	8*	2*
Jefferson County.....	M	rob	yr	G	b	W	2*	1*	
Jersey Black.....	M	fl	dr	G	f	W			
Jersey Sweet.	M	r	yr	VG	b	a	5*	14*	
Jewett's Red	M	rob	r	B	b	W	9*		4*
Jonathan.....	M	rc	yr	VG	b	W	9*	22*	2*
Judson.....	L	c	grs	G	b	a			
Julian.....	M	flc	wr	G	k	S			9*
Junaluskee.	M	rob	g	VG	b	W		1*	3*
Kent Beauty....	L	rc	rs	G	b	a			
Kentucky Red(6)	M	rc	gy	G	b	A		3*	6*
Keswick Codlin.....	M	rc	gy	G	b	a	3*	12*	2*
King David.....	M	r	r	B	b	W			
Kinnarid.....	M	fl	yr	G	b	W		3*	1°
Kingbridge (White).....	M	ob	gy	G	b	a	1*	3*	2*
Lady.....	S	fl	yr	VG	b	W	3*	7*	2*
Lady's Sweet.....	L	r	yr	VG	b	W	9*	6*	1*
Lankford.....	L	rc	gr	G	m	W			
Lansingburg.	M	rfl	yr	G	m	W		6*	
Late Strawberry.....	M	r	yr	VG	b	a	11*	12*	2*
Lawver.....	L	rob	yr	VG	b	W		3*	
Lehigh (L. Greening).....	M		y	G	b	W			
Lilly (L. of Kent).....	L	rc	g	VG	b	S			
Limber Twig.....	M	rob	yr	G	m	W	3*	10*	8*
Liveland Raspberry.....	M	r	ys	G	b	e			
Longfield.....	M	rc	yr	G	k	A			
Louise (Princess L.).....	L	rc	wir	G	f	W			
Lorne.....	L	rfl	gr	VG	b	W			
Loudon Pippin.....	L	fl	yr	G	m	W	2*	4*	1°
Lowell (10).....	L	rc	yr	VG	b	a	4*	12*	2*
Lyscom.....	L	r	gy	G	b	a	4*		2*
Magog (M. Red Streak).....	L	rob	gy	G	b	W			
Mahomet.....	M	rob	yr ^s	VG	b	a	3*		2*
Maiden's Blush.....	M	r	yr	G	b	a	10*	33*	7*
Major.....	L	rfl	gy	VG	b	W		1*	
Mangum.....	M	rob	gr	VG	b	W	1*	5*	8*
Mann.....	M	rob	yr	VG	b	W	3*	1*	
Margaret (Ea. M.).....	M	r	rs	VG	b	S			
Mary Womac.....	L	rfl	yr	VG	b	W		1*	
Mason's Orange.....	VL	ob	yr	G	b	W		1°	
Mason's Strange.....	M	fl	y	VG	b	W		2*	2°
Mattamusket.....	S	fl	yr	G	b	W		2*	2*
Maverack Sweet.....	M	rob	yr	VG	m	W			5*
Maxy.....	M	re	yr	G	b	W		2*	
McAfee (11).....	L	rob	gr	VG	b	W	2*	12*	
McIntosh Red.	M	rob	yr	VG	b	W	1*		
McLellan.....	M	rob	yr	VG	b	W	4*	3*	
McMahan's White.....	L	rob	yr	G	b	A	2*	2*	
Mellinger.....	M	rc	ywi	VG	b	W		1*	
Melon.....	M	rob	rs	B	b	W	5*	4*	
Mexico.....	M	rob	ys	VG	b	A	2*		
Milam.....	M	r	rs	G	b	W	1*	9*	
Milden or Milding.....	L	fl	rs	VG	b	W	3*		
Minister.....	L	ob	yr	G	b	a	6*		2*
Minkler.....			rs					3*	
Missouri Pippin.....	L	rob	yr	G	m	W		6*	

Varieties of Apples—Continued.

Names	Size	Form	Color	Quality	Use	Season	N. Div.	C. Div.	S. Div.
Monmouth (12).....	L	fl	yr	VG	b	W	4*	5*
Moore's Sweet.....	M	rob	r	G	k	W	2*	3*
Mother.....	M	re	yr	B	b	W	12*	11*	1*
Munson Sweet (13).....	M	fl	yg	G	b	a	3*	3*	2*
Nansemond (N. Beauty).....	M	rob	rs	VG	b	W	...	2*	1*
Nero.....	M	r	r	G	m	W
Newell (M. Winter).....	M	rob	yr	G	m	W
Newtown Pippin.....	L	rob	gy	VG	b	W	4*	14*
Newtown Spitzenburg.....	M	ob	yr	VG	f	W
Nickajack.....	L	rob	rs	G	b	W	1*	10*	9*
Nonpareil Russet.....	M	r	yg	G	b	W	2*	2*
Northampton.....	M	fl	rs	VG	f	W	2*
Northern Spy.....	L	re	yr	B	b	W	18*	14*	1*
Northwestern Greening.....	L	re	gy	G	m	W
Oakland (14).....	M	rob	yr	VG	f	W	1*
Oconee Greening.....	M	ob	y	G	A	1*	2*	6*
Ohio Nonpareil.....	L	rob	yr	VG	b	a	2*	3*	1*
Ohio Pippin (15).....	L	rob	yr	G	W	1*	1*
Oldenburg.....	M	rob	yr	G	m	S	22*	23*	5*
Orange Pippin.....	M	ob	y	VG	b	A	3*	2*
Orange Winter.....	1*
Ortley (16).....	M	ob	gy	VG	b	W	2*	7*	1*
Otoe Red (36).....	M	rob	yr	VG	b	W	3*
Peach of Montreal.....	M	re	ys	VG	b	A	3*
Peach Pond Sweet.....	M	fl	rs	VG	f	A	3*	2*	2*
Peck's Pleasant.....	M	r	gy	VG	b	W	11*	14*
Peerless.....	M	r	s	G	m	W
Perry Russet.....	M	re	ru	G	b	W	1*	3*
Pewaukee.....	L	fl	rs	G	b	W	1*	2*
Phillips' Sweet.....	M	rob	rs	VG	b	W	1*	1*
Pickard.....	M	rob	ry	G	f	W	1*
Pilot.....	L	rob	gyr	VG	b	W	2*
Pittsburg (Pippin).....	L	fl	gy	VG	b	W	2*	1*
Pleasant Valley (Pippin).....	M	rob	gy	VG	b	W	1*	*1
Plumb's Cider.....	M	re	gyr	G	b	A	1*	3*
Pomme Grise.....	S	rob	yr	B	f	W	7*	2*
Porter.....	L	ob	gy	B	b	A	16*	16*
Premium.....	M	re	y	VG	b	W	2*
President.....	L	rob	y	G	f	A	1*	1*
Primate.....	M	re	gy	B	f	a	10*	13*	3*
Progress.....	M	rob	y	G	b	W	1*	1*
Prother's Winter.....	M	e	yr	G	b	W	2*
Pryor Red.....	L	rob	yr	VG	b	W	7*	6*
Pumpkin Sweet (17).....	L	rob	y	G	b	W	6*	2*
Pyle's Winter.....	L	rob	rs	VG	b	W	2*
Rambo.....	M	fl	yr	VG	b	a	6*	19*	2*
Ramsdell's Sweet.....	M	ob	yr	G	b	a	3*	7*
Rawle's Genet (18).....	L	re	yr	VG	b	W	2*	25*	5*
Red Astrachan.....	L	r	yr	G	b	S	25*	26*	14*
Red Canada (19).....	M	rob	yr	B	b	W	7*	8*
Red Cathead.....	L	re	yr	G	b	a	1*
Red Crab.....	S	r	r	C	a	3*
Red Gilliflower.....	L	e	yr	G	f	W
Red June.....	3*	2*
Red Rance.....	M	rob	rs	VG	b	W	1*
Red Stripe.....	M	obe	yr	G	b	S	5*
Retka Malenka.....	S	re	rs	G	k	A
Rhode's Orange.....	M	rob	yr	G	f	S	3*
Ribston (Pippin).....	M	r	yr	VG	b	W	10*	2*
Richard's Graft.....	M	rob	rs	VG	b	a	2*

Varieties of Apples—Continued.

Names	Size	Form	Color	Quality	Use	Season	N. Div.	C. Div.	S. Div.
Ridge Pippin..	L	rc	yru	G	m	W	1*	4*	1*
R. I. Greening	L	rob	gy	VG	b	W	20*	12*
Robertson's White..	M	rob	gy	G	b	a	..	2*	2*
Robinson (R.'s Superb).	L	G	b	A	3*
Rock (Pippin) (20)	M	c	y	..	m	W	..	1*
Rockport Sweet.	M	rob	gy	VG	f	W	2*
Rolfe (MacComber)	L	r	yrs	VG	b	A
Romanite (South).	S	rc	yr	VG	b	W	..	3*	8*
Roman Stem	M	r	yru	VG	b	W	2*	15*	1*
Rome Beauty	L	r	yr	G	m	a	1*	16*	1*
Roxbury Russet.	M	rob	yru	VG	b	W	15*	11*	1°
Saint Lawrence	L	fl	yr	VG	m	A	12*	5*
Salome.	M	rob	yrs	VG	m	W
Sarah..	L	fl	rs	VG	b	a	1*
Saxton (21).	M	rob	yr	G	f	A	1*	1*	2*
Scott Winter	M	rc	rs	G	m	W
Sheppard's Sweet..	M	rc	rs	G	f	a
Shiawassee (Beauty)	M	fl	ry	VG	b	W	3*	1*
Shockley.....	S	rc	yr	G	b	W	..	11*	13*
Simmon's Red (22).	M	ob	yr	VG	..	S	1*
Smith's Cider.	L	rob	yr	G	b	W	2*	24*	2*
Smokehouse	L	rob	yr	G	b	W	1*	12*	2*
Somerset (Maine)	M	fl	rs	VG	f	S	1*
Somerset (N. Y.).	S	rc	yru	VG	f	a	2*
Sops of Wine (23).	M	r	yr	G	b	a	9*	13*	9*
Spice Russet	S	flc	yru	VG	f	W	1*	1*
Spitzenburg (24).	M	rob	yr	B	b	W	2*	8*	1*
Stansill.....	M	rob	gy	G	f	W	1*
Stark...	L	rc	yr	G	f	W	3*	4*
Starkey.....	L	obr	ys	G	m	A
Stevenson's Winter	M	rob	y	G	f	W	..	6*	14*
Striped Anis.....	S	1*
Summer Bellefleur	M	rc	y	G	b	A	..	3*
Summer Hagloe	L	rob	rs	VG	b	S	2*	5*	2*
Summer King...	M	fl	yr	G	b	S	..	2*	1*
Summer Paradise	L	r	gy	VG	f	a	2*	2*
Summer Pearmain..	M	ob	yr	B	f	S	5*	17*	7*
Summer Pippin (25).....	M	obc	yr	G	b	S	6*	6*	2*
Summer Pound Royal.....	L	rc	yru	G	m	a	2*	2*
Summer Queen	L	rc	yr	G	b	S	4*	14*	4*
Summer Rose.....	S	r	yr	B	f	S	5*	20*	3*
S. Seek-no-further.	M	obc	y	VG	f	S	1°
Susan's Spice.....	M	fl	yr	G	f	A	1°
Sutton (Beauty).	M	rob	rs	VG	b	W	2*
Swaar.....	L	rob	gy	B	b	W	4*	8*
Swayzie.....	S	rc	yru	VG	f	W
Sweet Bellet et Bonne..	M	rob	yru	VG	b	W	2*	1*
Sweet Bough.....	L	ob	gy	VG	b	S	14*	15*	6*
Sweet Pear.....	M	rc	y	VG	f	A	1*	1*
Sweet Winesap.....	M	fl	rs	VG	m	W	1*	3*
Tolman Sweet.....	M	r	gy	VG	b	W	19*	13*
Taunton.....	L	rc	yr	G	b	A	1*	10*
Terry (T. Winter).....	S	rc	yr	G	m	W
Tetofsky.....	M	flc	yr	G	k	S	9*	5*	1*
Tinmouth.....	M	fl	yr	VG	f	W	3*
Tompkins King (26).....	L	r	yr	VG	b	W	12*	9*
Townsend (27).....	M	rob	rs	G	m	S	2*	4*	2*
Trenton Early.....	M	r	y	G	f	S	1*	4*	2*
Twenty Ounce (28).....	L	r	rs	VG	b	a	11*	7*	4*
Utter.....	M	rob	rs	G	fk	A	2*

Varieties of Apples—Continued.

Names	Size	Form	Color	Quality	Use	Season	N. Div.	C. Div.	S. Div.
Vandevere.....	M	fl	yr	G	m	W	2*	5*	
Vanhoy.....	L	rc	yr	G	b	W			
Victuals and Drink.....	L	ob	yr	G	f	W	2*	1*	
Virginia Beauty.....	M	rc	yr	VG	b	W			
Virginia Greening.....	L	fl	gy	G	m	W	1*	2*	1*
Wagener.....	M	rob	yr	B	f	W	9*	11*	
Warfield.....	L	fl	y	G	b	A		1*	
Washington Royal.....	M	rob	gy	G	m	W	3*	1°	
Washington (Strawberry).....	L	rc	yr	VG	b	a	6*	2*	
Water.....	M	rc	yr	VG	f	W	1*		
Waugh's Crab.....	S	rc	rs	G	C	W		3*	3*
Wealthy.....	M	rob	r	VG	b	a	13*	5*	
Webb.....	M	r	y	G	f	W			1*
Wellford's Yellow.....	S	rob	gy	G	m	W		2*	
Western Beauty (29).....	L	rob	rs	VG	b	S	1*	4*	
Westfield Seek-no-further.....	L	rc	yr	B	b	W	8*	9*	
Whinery (W. Winter).....	M	rc	rs	G	m	W			
White Doctor.....	L	rob	gy	G	b	a	2*	2*	
White Juneating (30).....	S	r	gy	G	b	S	1*	7*	
White Paradise (31).....	M	rfl	yr	G	m	W		3*	
White Pippin.....	L	rob	gy	VG	b	W	1*	8*	2*
White Ramo.....	M	rob	gy	G	m	a		2*	
White W. Pearmain.....	M	rc	yr	VG	b	W	1*	11*	
Williams (Favorite).....	M	rc	yr	G	m	S	15*	10*	4*
Willis Sweet.....	L	r	yr	VG	b	S	1*		2*
Willow Twig (32).....	M	rc	yr	G	b	W	3*	16*	1*
Wine (33).....	L	r	yr	VG	b	W	3*	12*	
Winesap.....	M	r	yr	VG	b	W	6*	33*	10*
Winter S. Paradise.....	L	rob	gy	VG	f	W	3*	10*	
Wolf River.....	L	rob	r	G	b	W	1*	3*	
Wythe.....	M	fl	rs	VG	f	W		2*	
Yates.....	S	fl	yr	G	b	W		1*	11*
Yellow Bellefleur.....	L	ob	gy	VG	b	W	12*	15*	4*
Yellow June (34).....	M	rob	y	G	f	S		2*	8*
Yellow Newtown.....	M	rob	yg	B	b	W			
Yellow Transp'nt.....	M	rob	y	G	b	S	7*	3*	
Yopp (Favorite).....	L	rc	y	G	f	A			5*
York Imperial.....	L	fl	yr	G	b	W	1*	12*	
Zachary (Pippin).....	L	fl	rs	VG	b	W	1*		

Popular Synonyms: American Golden Russet³, Bachelor², Bradford's Best⁹, Carthouse⁷, Cayuga Red Streak²⁸, Champlain Nyak²⁵, Fall Queen of Kentucky², Fall Stripe²¹, Gilliflower (Cable's)¹, Hay's Wine³³, Hocking²⁷, Hominy²³, James River³², Kentucky Red Streak⁹, King of Tompkins County²⁶, Lady Finger³¹, Large Striped Pearmain¹¹, Lemon²⁰, Little Romanite⁷, May³⁰, McAfee's Nonsuch¹¹, Nantahalee³⁴, Neverfail¹⁸, Newtown Spitzenburg²⁴, Oakland County Seek-no-further¹⁴, Old Nonsuch¹⁹, Orange¹⁰, Orange Sweet¹³, Otoe Red Streak³⁶, Pennsylvania Red Streak³³, Pimme Royale²⁵, Pound Sweet¹⁷, Queen Anne¹⁰, Rambo²⁹, Red Cheek Pippin¹², Red Everlasting²², Red Juneating⁴, Richfield Nonsuch¹⁹, Shannon¹⁵, Snow Apple⁶, Steele's Red Winter¹⁰, Summer²⁹, Sweet June⁸, Tallow Pippin¹⁰, Tulpehocken⁵, Vandevere of New York²⁴, White Bellflower¹⁶, Woolman's Long¹⁶.

VARIATION IN BEN DAVIS GROUP

The tendency of fruits to vary is well illustrated in the case of the Ben Davis group of apples. Thanks to the work of Mr. J. K. Shaw of the Massachusetts Agricultural College,* this variety has been thoroughly studied with respect to

* Massachusetts Agricultural College, 22nd Annual Report.

its variational tendencies. These variations may be grouped, for our purpose, under two general heads. First, those variations from the parent stock which have become so marked as to give rise to new varieties to which distinct names have been given, and second, those variations within an established variety which are due to climatic or other environ-

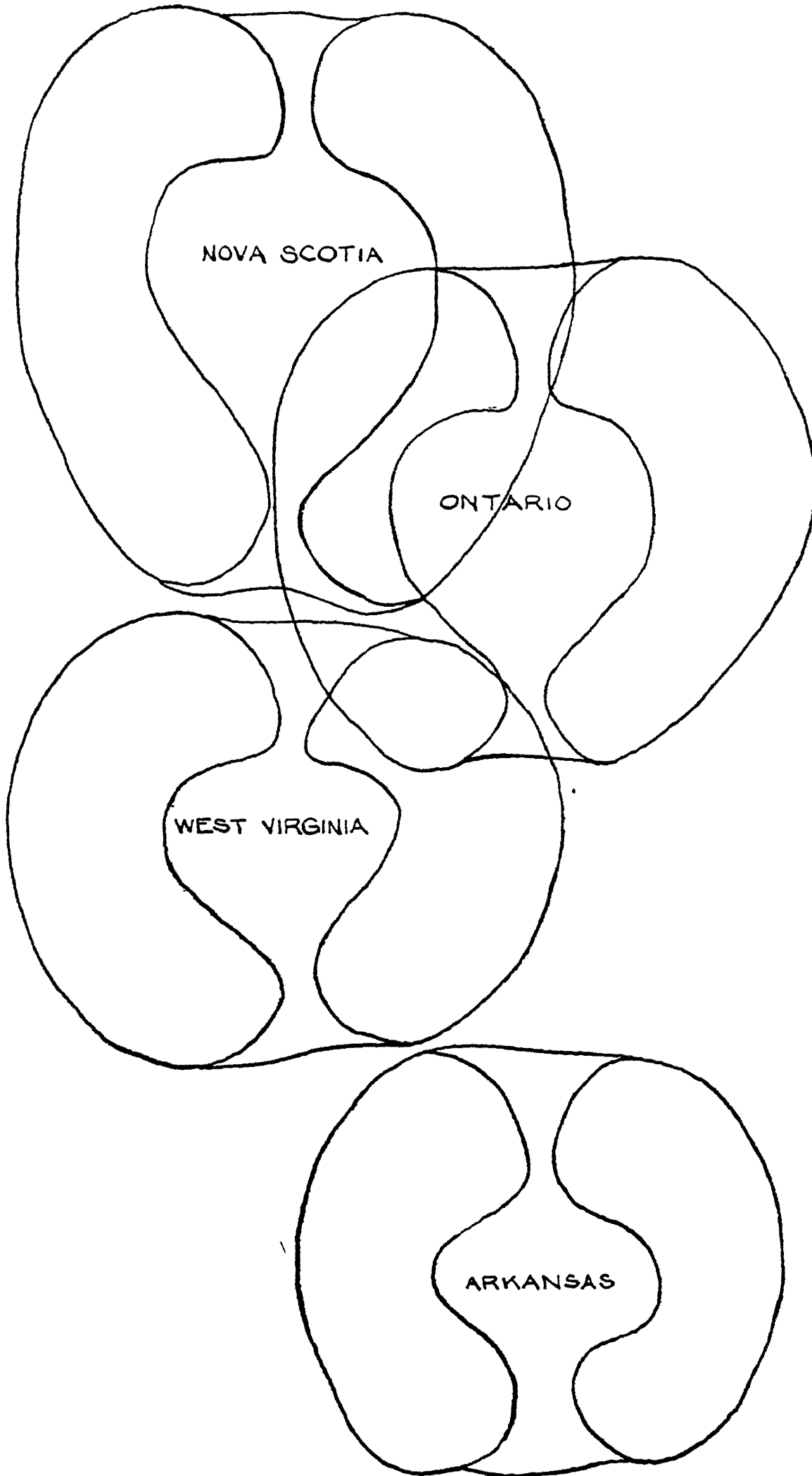
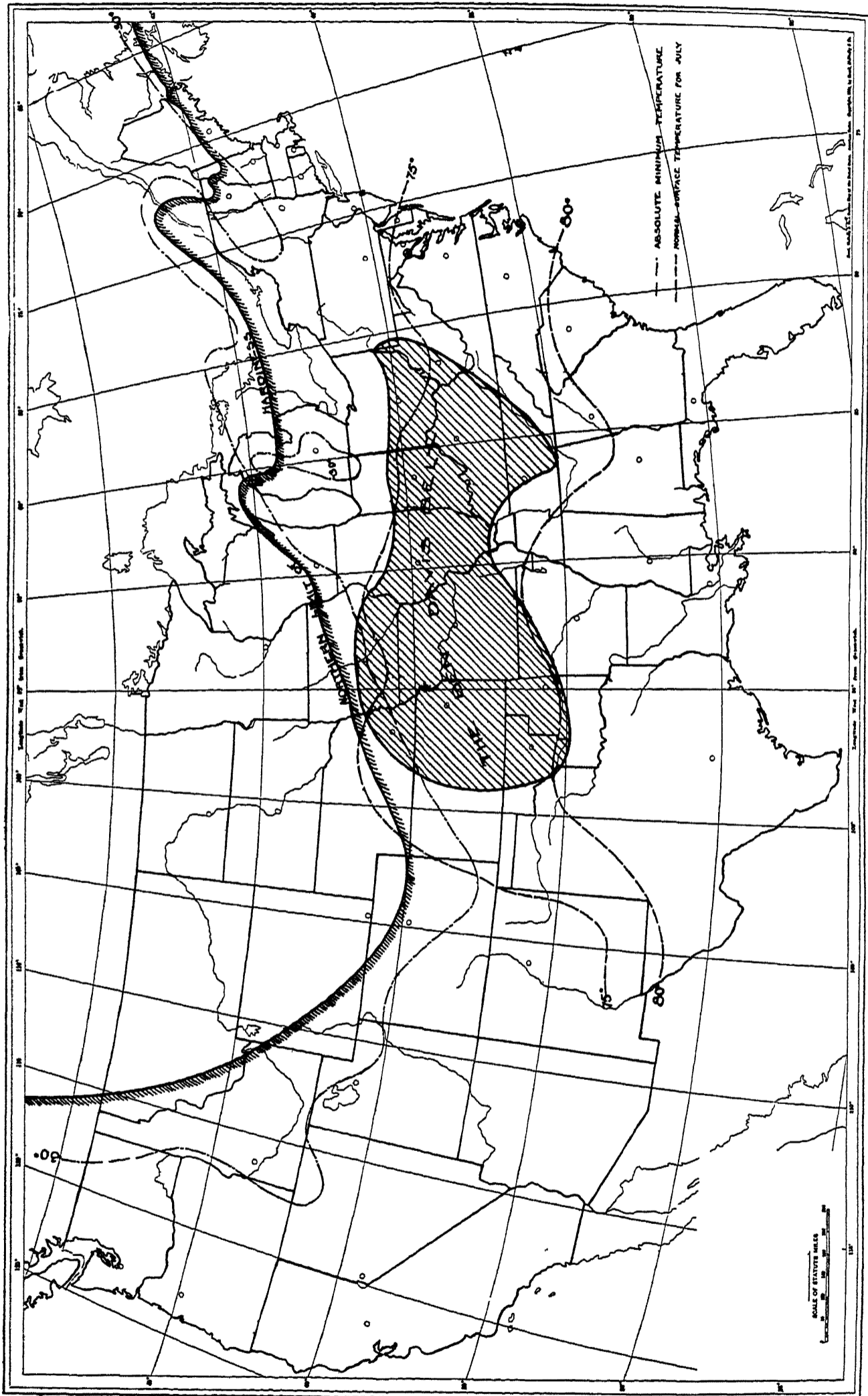

Fig. 1. Typical Forms of the Ben Davis. Nova Scotia, the oblong form. Ontario, the round conic form. West Virginia, the oblate form. Arkansas, the roundish form.



DISTRIBUTION OF THE BEN DAVIS

mental conditions but which are not marked enough to give rise to a new variety See *Variation, Causes of*

As an example of the first the following list of varieties which have originated from common parentage, is given

Arkansas Beauty	Flat Ben Davis
Arkansas Belle	Gano
Ben Davis	Improved Ben Davis
Ben Hur	Nordhaussan
Black Ben Davis	Ostrakavis
Coffelt	Paris
Cole Davis	Shackleford
Eicke	Shirley
Etris	Sweet Ben Davis
Extra	White Ben Davis

"Many of these are of minor importance, and doubtless some are not propagated and will soon disappear from cultivation. Almost without exception they are of southern origin and best adapted to growing under southern conditions. When grown north of the southern Missouri and Ohio valleys they are inferior in quality, though fairly hardy and bearing good crops.

"The fruit is generally roundish conic in form, nearly regular, with regular cavity and basin, the latter generally more or less abrupt. In color, greenish yellow, usually overspread with bright red, more or less striped. The flesh is generally white and firm, of medium or coarse texture. They are of only moderately good quality but long keepers and good shippers. With one exception they are more or less acid in flavor, generally a mild subacid. A notable characteristic common to all varieties examined was the presence of a pistil point or the persistent base of the pistil, a character rarely found in apples not belonging to this group."

In addition to the above the following are believed to belong to the Ben Davis group, but evidence is wanting to make the author certain.

Breckinridge	Hastings Red
Chicago	Highfill
Collins (Champion)	King David
Florence	Marion Red
Givins	

As to the causes which give rise to changes sufficient to warrant the name of

a new variety, we are compelled to admit a great deal of ignorance. About the best we can do is to fall back upon that general fact of tendency to vary which seems to characterize the whole biological world.

A good illustration of variations due to environmental causes as, for example, climate, is shown in the accompanying diagram of the Ben Davis apple as grown from Nova Scotia to Arkansas

"Considering the 'results of all the measurements taken' we find that in the extreme Northeast the Ben Davis is much elongated, and as we go South and West it becomes less elongated and more flattened, till we reach West Virginia and Kentucky, where it becomes a decidedly oblate apple. In the Ozarks it is a little longer and in Southern California still longer, and in British Columbia it is almost as much elongated as in Nova Scotia and neighboring regions. * * * Apples from districts near large bodies of water were noticeably elongated. The conclusion seems to be that 'beginning in the southern Allegheny mountains and in Southern California and going north the apples become more elongated and that the elongation is much more pronounced in the vicinity of large bodies of water, either salt or fresh.'"

The many variations in apple varieties arise from many causes which may be grouped as cultural, using the word in the broad sense; soil and climatic. Of climatic influences, temperature is the most potent.

The methods pursued in the growing and in the care of the trees have great influence in the character of the fruit. It is affected in every way, in size, form, color, keeping quality, shipping quality and dessert quality.

As to the effect of soil types on the variation of apples, not enough is known regarding this question to make any definite generalizations on the subject.

Variation in the form of the Ben Davis, and probably in other sorts as well, is due principally to the temperature during a period of about two weeks following blossoming. The lower the temperature the

more elongated the apple. This elongation is seen in apples grown near large bodies of water, which lower the temperature at this season of the year, and in seasons when the temperature is low, owing to seasonal fluctuations. This influence is also seen in the form of apples on different parts of the tree. Those in the lower north portion are more elongated than those from the warmer, upper south portion.

The attainment of the highest quality, appearance and keeping quality is very largely dependent on the warmth and length of the growing season. This may be measured with a fair degree of satisfaction for the apple-growing regions of North America by an average of the mean temperatures for the months of March to September inclusive. This is called the mean summer temperature, and gives temperatures ranging from 52 to 72 degrees. Factors determining the mean summer temperature in a given orchard are latitude, elevation, site and aspect, soil, culture, prevailing winds and sunshine.

A summer mean too low for a variety will result in greater acidity, increased insoluble solids, greater astringency, less coloration, decreased size, scalding in storage.

A summer mean too high for a variety results in uneven ripening, premature dropping, rotting on the trees, poor keeping quality, lack of flavor, mealiness, less intense color, decreased size.

The accompanying map (p. 436) shows the distribution of the Ben Davis with the northern limit of hardiness.

APPLE DISEASES

Alternaria Decay

A decay of apples caused by a species of *Alternaria* was first described from Colorado by Longyear. This fungus entered the apple at the blossom end and produced a cob-webby growth of mycelium around the seeds. An *Alternaria* has been found a number of times associated with apple decays. This fungus usually occurs on injured places such as the blos-

som end injured by insects or broken places in the skin. Associated with other fungi this *Alternaria* forms a rather thick, dry covering of mycelium over the injured place. The fungus does not usually penetrate very deeply in such cases but when ripe apples are inoculated from pure cultures, it is found to be capable of causing a complete decay. This fungus alone has been reisolated a number of times from decaying apples which had been inoculated, thus proving that it caused the decay. The apple decay *Alternaria* differs sufficiently from a species of the same genus which has been found repeatedly on dead spots in apple leaves and on dead parts of other plants so that the two fungi can be distinguished readily in culture. The *Alternaria* from apple leaves has not been found to cause decay of the fruit upon inoculation.

W. J. MORSE

Apple Tree Anthracnose

Neofabraea malicorticis (Cordley)
Jackson

H. S. JACKSON

The apple tree anthracnose is, with the possible exception of the apple scab, the most serious fungus disease with which apple growers in the Northwest have to deal. In general, the disease is characterized by the formation of dark colored sunken cankers in the bark of the younger branches. These are most abundant on branches under two or three inches in diameter, but are not uncommonly found on branches of larger size.

When they occur on older branches having a thick bark, the cankers may not always penetrate entirely to the wood. Usually, however, the bark in the mature cankers is found to be entirely dead, the cambium destroyed and the sap wood discolored to a limited extent.

Development of the Cankers

By close observation one may find the young cankers beginning to develop commonly early in November. It is possible that in seasons of early fall rain they may begin to appear much earlier.

They begin their development as small reddish brown spots in the bark. These

when first observed are circular and about one-half inch in diameter and are not sunken. If one cuts into the bark beneath one of these spots the tissues are found to be discolored and to present a water soaked appearance. The discolored area is found soon to extend to the cambium, where it spreads out and may in some stages of the development of the cankers be more extensive in that region than the discolored area on the surface would indicate. The spots develop very slowly, if at all, during the winter months, but spread quite rapidly during March and April. As they enlarge they gradually become elliptical in outline, the surface becomes flat, then slowly sinks.

Sometimes the bark of developing cankers shows bands of slightly varying color, giving the appearance of concentric zones. This is doubtless due to alternating

periods of rapid and slow growth induced by variations in the weather conditions. In early stages of rapidly growing cankers an irregular crack may appear in the bark and drops of fermenting sap may exude.

In the early spring, when the warm weather induces renewed activity in the tree, the cankers develop rapidly. The bark soon dries and sinks and this condition together with the normal growth in the surrounding healthy bark produces a tension which results in the formation of a crack in the bark at the edge of the canker. The spread of the fungus ceases as soon as the cambium becomes active in the spring.

After the cankers reach the full size, which occurs in early May, further activity is confined to changes which take place in the dead bark within the canker-



Fig. 1. *a*, Canker of Anthracnose on Apple Branch. Note pustule of fungus in bark of canker. *b*, Canker Two Years Old Showing Fruiting Bodies of the Perfect Stage.

er. If a mature canker is examined in midsummer, little elevations in the bark are easily observed. They are at first more or less conical in shape and finally burst the outer layer of the bark exposing a cream colored mass of fungous tissue. These are the fruiting structures of the fungus and the spores are produced in them in great abundance.

In late summer or early fall the mature cankers are found and may be from one-half inch in diameter up to eight to 10 inches long by three to four broad. Frequently large cankered areas may be formed by several smaller ones becoming confluent. Mature cankers have a definite limiting crack separating them from the healthy tissue; there is usually a definite ridge surrounding the canker caused by the slight formation of callus tissue at the edge under the diseased bark. The bark is sunken, dry and dead, and darker in color than healthy bark. Thickly scattered over the surface one finds the little cracks described above which are formed when the fungus bursts forth. These cracks are transverse or triangular, seldom if ever, vertical. (Fig. 1-A shows a typical canker.) In old cankers the fungus tissue exposed by the cracks turns black and the bark gradually becomes loose at the edges and drops out, leaving ugly wounds. Bark may cling in the cankers, however, for at least three winters. The wounds, if not too large, slowly heal over by the formation of callus.

Injury Caused by the Disease

On account of the nature of the disease it is difficult to estimate the amount of the injury resulting from its ravages. Under ordinary conditions few to many cankers may be found on the branches of the trees in infected orchards. Sometimes twigs are girdled by the formation of a small canker, which extends around the stem as is shown in Fig. 2. Not infrequently larger branches are girdled where several cankers grow together. Sometimes trunks of young trees are girdled in this way.

It is evident that the disease in any degree of severity interferes with the nor-



Fig. 2. Apple Twig Girdled by Small Canker of Anthracnose.

mal function of the bark and so hinders the proper distribution of elaborated food in the tree. Branches are weakened by the presence of the cankers and frequently break when heavily set with fruit. The woolly aphid not uncommonly works under the bark at the edge of cankers and further saps the vitality of the tree and interferes with the normal healing over of cankers. Large cankers heal slowly and the wood may be exposed for considerable periods, thus affording opportunity for the entrance of fungi which cause heart rot.

Distribution

As a serious orchard disease the apple tree anthracnose is peculiar to the Pacific Northwest. It is known to occur in British Columbia, Washington, Oregon,

and has been reported doubtfully from Idaho. It has not been recorded in California to our knowledge, though it is not improbable that it occurs in the northern counties, since it is common in Jackson and Josephine counties in Oregon. It is most serious in those sections having considerable rainfall west of the Cascade mountains. It is rarely a serious disease in the fruit sections east of the Cascade mountains. It has been reported once from Nebraska.

Life History Studies

The apple tree anthracnose has probably occurred in the Northwest for many years. It began to attract attention as an orchard trouble during the period from 1891 to 1893. The serious nature of the disease was realized at that time and through the efforts of the Boards of Horticulture of Oregon and Washington, the United States Department of Agriculture sent Professor M. B. Pierce to investigate this trouble. He made considerable study of this disease in both Oregon and Washington but made no official report. The records of his work are contained in extracts of letters published in the Second Biennial Report of the Washington State Board of Horticulture and in the Fifth Biennial Report of the State Horticultural Board of Oregon. It is evident from these reports that Pierce recognized the true nature of the disease and probably isolated the causal fungus and studied it in culture and produced the disease by inoculation.

The first published work regarding this disease was made by Professor A. B. Cordley (1900) of the Oregon Experiment Station, who published a full statement of the life history of the disease and a description of the organism causing it, together with the results of inoculation work. He named the fungus *Gloeosporium malicorticis*. At about the same time Dr. C. H. Peck described the same fungus under the name of *Macrophoma curvispora*. The writer has used the former name upon the grounds that Cordley places the fungus more nearly in the proper genus, and since the name which he proposed

has of late come into more general use. The disease was studied in Washington by Lawrence (1904) who verified all of Cordley's work and also records many interesting and important biological phases of the disease. He was the first to publish an account of the disease as a cause of a rot of stored fruit.

In 1906, on account of the fact that many points regarding the life history of the disease had not been thoroughly worked out, the Oregon Experiment Station undertook a detailed investigation of the life history and control of this disease.

Mr. C. C. Cate, a graduate student, made a thorough orchard survey of the disease in various parts of that state in an effort to determine whether any information could be obtained regarding the susceptibility of varieties, and whether the conditions of the soil had anything to do with the degree of susceptibility. He found very little evidence to indicate that soil conditions had any influence upon the abundance of the trouble. The following quotation (Cate, 1908) indicates the results of the investigations regarding the susceptibility of varieties:

"From investigations made during the past summer, it was found that Anthracnose attacks practically all varieties of apples, although some are more susceptible than others. Those most susceptible are Baldwins, Spitz and Jonathans; next are Newtowns, Greening, Gravenstein and most of the summer varieties, while those attacked only slightly are the Ben Davis, Northern Spy, Wine-sap and Blacktwig. No varieties seem to be entirely immune and occasionally some of the least susceptible varieties are nearly or entirely ruined by the disease. In the varieties like Baldwin and Spitz, the cankers are of all sizes and most of them extend very deep and hence greater damage is done, while on the Ben Davis cankers or wounds are smaller and more superficial, hence very little damage is done to trees of this nature."

The writer began the study of this disease in the summer of 1909, which has been continued as time would permit, since that date. In the course of this

study many of the results of previous workers have been confirmed and some important points added to our knowledge of the life history of the causal fungus.

Early in the work a search was made for a possible ascogenous stage in the life history of the fungus. In November, 1909, while studying the characters of "two year old" cankers, that is, cankers resulting from infection in the fall of 1907, the apothecia of a discomycete belonging to the family *Mollisiaceae* were found occupying the position of the acervulus of the previous season (1908). (See Fig. 1-B.) Careful search revealed the fact that the apothecia of this fungus were nearly always found in the dead bark of cankers one year after the development of the conidial stage. The writer has had this fungus under observation now for four seasons and has never failed to find it in the bark of cankers two years after infection in any orchard in which he has searched at the proper season. No other ascomycete has been found at all constantly associated with the cankers. We have also observed the same discomycete in the old bark of cankers on pear trees.

Cultures obtained by most careful methods from the germinating ascospores were used to inoculate healthy Spitzenburg apple trees. In all cases cankers resulted which were characteristic of apple tree anthracnose. The inoculations were made on December 12, 1910, and in September, 1911, nine months after the inoculation, cankers resulting from the inoculation were examined and found to bear the typical conidia of this disease. In this way it was proven that the fungus found in the old cankers was the perfect or ascogenous stage of the imperfect or conidial fungus, *Gloeosporium malicorticis*. This ascomycete was found to be undescribed and the name *Neofabraea malicorticis* (Cordley) was given to it by the writer (1913). The economic importance of the discovery of this perfect stage lies in the fact that it proves that the old cankers are a source of infection, as well as the new cankers. It has also been shown that

occasionally conidiospores are also developed on these same cankers, around the edges of the apothecia of the perfect stage. We have also determined that conidia may be developed in the bark of cankers three years after infection.

Kinds of Trees Affected

The disease was first recorded on the apple, and for some time the fact of its occurrence on other hosts was not observed, or at least did not attract attention. Lawrence (1904) was the first to record the occurrence of the disease on the pear. He also produced the disease by inoculation on this host. Cate (1908) was first to record the disease upon the



Fig. 3. Cankers on Pear Branches.

quince. It has since been found to develop abundantly upon the quince, though recent developments indicate that the fungus on that host may be due to a different species. It has been found not uncommon on the pear, particularly on the Winter Nelis, though it is not to be considered a common or serious pear disease. On account of the fact that the disease under discussion is confined almost entirely to the Pacific Northwest, it has been assumed by a number of investigators that there was a native host on which the fungus occurred previous to the introduction of cultivated fruit, and that when the apple was introduced into the North-

west this fungus found it a favorable host on which to develop. Up to the present time no one has yet determined what this native host is, or at least no published record has been made.

Disease on Fruit

The apple tree anthracnose is not uncommon as a rot of the fruit as shown in Fig. 4. This may be developed in the orchard, especially if the fruit is allowed to hang late on the trees, or may be developed as a storage rot on fruit which is perfectly sound when stored.

Lawrence (1904) seems to be the first to have recorded this disease as a rot on the fruit.

Cate (1908) also found the disease common upon apple fruit and produced the rot by inoculation. In the season of 1911 this disease developed abundantly and seriously as a rot on stored fruit both under ordinary storage conditions and in cold storage. The writer has seen boxes of Spitzenburg apples kept in storage until May in which 90 per cent of the fruit was affected with this disease. The disease seems to be more abundant on the fruit, as would be expected, in seasons of early fall rain or when, on account of weather conditions, picking is delayed.

The most obvious line of attack for the control of this trouble on the fruit is to control the disease in the orchard by proper spraying methods. The disease

has developed, however, in some cases, in considerable percentage in orchards in which anthracnose was not present or present only in very slight amount, not sufficiently to account for any large percentage of infected fruit. This has been observed both in Hood River and the Willamette valleys. This fact suggests that a further study of the disease should be made under these conditions in an effort to determine the source of infection and whether or not the fungus may occur under conditions not at present well understood.

Methods of Treatment

As soon as the nature of the disease and the nature of the life history of the fungus causing it came to be understood a method of treatment at once suggested itself. Since the infection by the fungus takes place in the fall and early winter, after the fall rains begin, it is evident that spraying in the summer and fall is a logical method of attack, and this general method has been recommended since 1895, by Pierce, Cordley, Lawrence, and those who have made a specialty of this disease. Both lime-sulphur and Bordeaux mixture have been used in the winter strength for this purpose, though the evidence is at the present time that Bordeaux mixture has given much more uniform and satisfactory results. The time of spraying has been difficult to



Fig. 4. Anthracnose Rot on Apples.

determine. The ideal time would be to spray before the first fall rains. In practically all sections of the Northwest where this disease occurs this would be before the fruit is picked, and it is found somewhat objectionable to use Bordeaux mixture before the fruit is picked because of the slight deposit on the fruit.

In many of the older orchards where the trees are close and it is found necessary to use props in case of a heavy crop, it is often impossible to get through the orchard with a spray machine before the crop is picked without knocking off considerable fruit. On the other hand many growers complain that, on account of unfavorable weather conditions which frequently prevail following picking, they are often unable to spray in the fall as recommended—until it is too late to be of any value—if the spraying is delayed until after picking is done. Others complain that on account of the press of work incident to picking and packing a large crop even in seasons of favorable weather conditions, they have not time to spray until the proper season is past. On the other hand it is evident that trees must be protected with a fungicide during the fall of the year in order to prevent infection.

Experiments which have been conducted to date indicate that good results are obtained by spraying once with Bordeaux mixture 4-4-50 before the first fall rains, or about the middle of September, following by another application, using Bordeaux mixture 6-6-50, after the fruit is picked.

It is possible that where growers give a late spray for codling moth that a combination spray could be applied, using Bordeaux mixture 4-4-50 and arsenate of lead, two pounds to 50 gallons, in the latter part of August. This would be used to take the place of the spraying suggested in the middle of September. It has not been fully demonstrated whether this suggestion will prove satisfactory in general practice. It is worthy of trial, however, by interested growers, and may prove to be the most satis-

factory solution of the problem for the grower who wishes to keep a comparatively clean orchard protected from infection by this disease

In orchards where the disease has obtained a foothold, however, the recommendations as given under the summary should be followed. For other supplementary methods of control see Summary of Recommendations.

SUMMARY

Life History Investigations

1. A disease known throughout the Northwest as Apple Tree Anthracnose or Black Spot Canker is caused by a fungus which, in the conidial stage, is a parasite causing cankers on the branches of apple and pear trees.

2. The cankers caused by this fungus cause the death of the tissue of the bark in which it develops and of the cambium, and spreads to some extent to the sapwood beneath.

3. Infection occurs in the fall and early winter and the cankers develop slowly during the early part of the dormant season and spread rapidly in the early spring, reaching their full size when the cambium resumes activity in the spring.

4. The fungus matures slowly during the summer in the dead bark of the cankers thus formed. Spores are produced in acervuli characteristic of the genera *Gloeosporium* or *Myxosporium* of the *Fungi Imperfecti*.

5. This conidial form has been named by Cordley, *Gloeosporium malicorticis*.

6. The fungus continues to develop in the dead bark of old cankers as a saprophyte and produces in the late summer or fall, one year after the maturity of the conidial stage, an ascospore form having the characteristics of the family *Mollisiaceae* of the *Discomycetes*.

7. The connection of this Ascomycete with the conidial stage has been proved by inoculation experiments.

8. This has been made the type of a suggested new genus called *Neofabraea*. The proper scientific name for the

fungus should now be *Neofabraea mali-cortuvis* (Cordley).

9. The conidial stage has been found commonly causing a rot of the fruit of the apple and the quince, both in the orchard and in storage.

10. Both the conidial and ascospore stages have been found in nature on the pear. Cankers have been produced on this host by inoculation with the conidial stage of the fungus isolated from the apple.

11. Cankers have also been produced by inoculation with the fungus isolated from the apple, on peach, prune and cherry branches, but no spores have been observed to be matured in these cankers. The occurrence of such cankers in nature has not been proved.

12. No evidence has been secured that new cankers are formed by the spread of the fungus in the tissues from old cankers. The fungus has, however, been isolated from the heart wood beneath cankers on branches of the apple, two years after the maturation of the conidial stage. The extent and importance of the fungus as a heart rot has, however, not been investigated thoroughly.

Recommendations

1. Where orchards are only slightly affected with anthracnose, or where it is considered advisable to spray as a matter of general orchard practice, growers are advised to spray once each year in the fall as soon as possible after the fruit is picked, using Bordeaux mixture 6-6-50, or try in a part of the orchard the use of the combination spray of Bordeaux mixture 4-4-50 and arsenate of lead, two pounds to 50 gallons, in the last codling moth spray as suggested above.

2. In orchards where the disease is on the increase and it is desired to make a special effort to prevent any further spread, growers should spray twice with Bordeaux mixture, 6-6-50, after the fruit is picked. The two applications should be about two or three weeks apart. If desired one application may be made before the fruit is

picked, using Bordeaux 4-4-50 and the other after the fruit is picked, using Bordeaux 6-6-50.

3. Where the disease is abundant and is seriously interfering with the growth and productiveness of the orchard and it is desired to clean up the disease in the shortest time possible, then it is advised to spray at least once before the fruit is picked with Bordeaux mixture, 4-4-50. This application should be made about the middle of September or before the first fall rains. If desired the combination spray suggested under (1) above may be used instead of the application in the middle of September. In addition, such an orchard should be sprayed twice with Bordeaux after the fruit is picked, using the 6-6-50 formula, as recommended in (2) above.

4. Growers who desire to spray before the fruit is picked but who object to the Bordeaux at that time should try the ammoniacal solution of copper carbonate, or some other copper compound which does not leave a deposit upon the fruit. It should be pointed out, however, that the efficiency of these sprays, as a control of apple tree anthracnose has not been thoroughly demonstrated.

5. It is advisable, where possible, to prune out all the more seriously infected branches before the spraying is done. The spraying is more important, however, and should be given the preference. The pruning may follow the spraying, especially if the work is done as soon as possible afterwards. All affected branches which are cut out should be immediately removed from the orchard and burned, since they would be a source of infection if allowed to remain on the ground.

6. In so far as it is practical it would be advisable whenever cankers are formed, to clean out the dead bark, and where the wounds are large to protect the exposed wood with grafting wax or paint. It has been shown that bark in cankers may be a source of infection for at least three years. The removal of the dead bark is further advisable, since, if allowed to remain, it offers pro-

tection for various insects, especially the woolly aphid.

7. If for any reason cankers are formed and are detected in the winter when very small, the development of the canker may be, in many cases, prevented by shaving off the thin outer layer of the bark. This will allow the cankers to dry out and will prevent, to a large extent at least, the formation of spores in the fall. This method would probably be practical only on young trees, and, in any case, should be considered only supplementary to spraying.

See *Black Spot Canker of Apple*.

Bibliography

- 1893-4. Washington State Board Horticultural Report, 1893-4, page 69.
 1900. Cordley, Oregon Experiment Station, Bulletin No. 60.
 1900. Cordley, Botanical Gazette, 30, page 48-f.
 1900. Peck, Torrey Botanical Club, Bulletin No. 57, page 21.
 1904. Lawrence Washington Experiment Station, Bulletin No. 66.
 1906. Cordley, Better Fruit, 1 and 5, November.
 1908. Cate, Oregon Countryman, 1 and 2, 1 and 3.
 1912. Jackson, Phytopathology, 2 and 2, page 95.
 1912. Jackson, Oregon Experiment Station, Crop Pest Report, 1911-13.
 BACTERIAL POME BLIGHT. See *Blight under Pear*.

Bitter Rot†

Glomerella rufomaculans

The apple bitter or ripe rot is the cause of some of the most extensive losses experienced by apple growers. It is due to a fungus which has been given a number of scientific names, the one by which it is now known being *Glomerella rufomaculans*. The disease occurs throughout nearly all the country east of Kansas and Texas, and is especially destructive in a broad belt from Virginia to Oklahoma. It is somewhat spasmodic in its occurrence and at times occasions almost total loss. It is stated that in four counties in Illinois in 1900 the loss, due to this cause alone, amount-

ed to \$1,500,000, and the estimated loss to the apple crop for the United States during the same year was \$10,000,000.

The fungus lives on many different plants, causing a ripe rot of their fruits, but is best known as causing the bitter rot of apples and the ripe rot of grapes. The first signs of the bitter rot on the apple are to be seen in a slight light-brown discoloration under the skin of the fruit. The spots increase rapidly in size, maintaining a more or less circular outline, and become darker brown in color. Soon the tissues underneath the spots soften and the area seems sunken. When the spots have attained a diameter of about half an inch, small black spots appear beneath the upper surface, through which they finally break, discharging pink masses of spores which are very sticky when moist. These black pustules are usually formed in rings, and as the spots increase in size a number of concentric rings may be seen. The brown coloration of the spots is an indication of the decayed condition of the tissues underneath, and there is usually a sharp dividing line between the sound and the diseased tissues. The fruit is seldom entirely destroyed although it is rendered almost worthless. The tissues are at first hard, followed by the breaking down of the cells, and the partially decayed portions usually have a pronounced bitter flavor, from which is derived the name bitter rot. The fruits never become excessively soft and mushy, but often dry into what are called "mummy" fruits.

It has been claimed that the fungus passes the winter in these fruits, spreading the infection the next season. While the spread of the fungus may be favored by the presence of the mummy fruits, yet a more important method has been found in the presence of cankers on the limbs of the trees. These are due to the same fungus as that occurring on the fruits, and their relation to the disease has been well established by Burrill and Blair, of the Illinois Station, and Von Schrenk and Spaulding, of the Bureau of Plant Industry.

From these cankers the spores are washed by the rains over the young fruits, causing their infection. The spread of the disease may often be traced to its source by the conelike infected area, with the canker at the apex. Alwood, of the Virginia Station, claims that infection sometimes takes place without the presence of cankers, and he thinks that mummy fruits are the principal source of primary infection. In the publications, both of the Illinois Station and the Bureau of Plant Industry, the authors recommend cutting out the cankers and thorough spraying of the trees with Bordeaux mixture, but Alwood advises caution in pruning, unless it can be done without material injury to the tree.

Marked differences in susceptibility of varieties to bitter rot have been noted. While no list can be given that will apply to all regions, yet in general the Yellow Newtown or Albemarle Pippin, Rhode Island, Willow, Huntsman, Northern Spy, Ben Davis, York Imperial, Grimes, and Winesap are subject to the disease almost in the order of enumeration, the Yellow Newtown seeming to be most liable to serious loss.

Certain conditions of weather influence the spread of the disease. It is favored by a hot, moist temperature, the fungus being very dependent upon the combination of high temperature and moisture for its development. During cool, dry summers little of the disease may be expected, and an outbreak may be checked if the mean temperature falls to and remains at or below 70 degrees Fahrenheit for a few days.

W. M. Scott, of the Bureau of Plant Industry,* gives an account of spraying experiments for the control of the bitter rot on apples. These experiments were carried on in 1905 on an orchard of Yellow Newtown or Albemarle Pippin trees in Virginia, and the conditions that season were so favorable for the development of bitter rot, as was shown by the large number of decayed fruits

*U. S. Department of Agriculture, Bureau of Plant Industry Bulletin 93

on unsprayed trees, that the conclusions are believed to be of general application. The Bordeaux mixture used in the experiments was composed of five pounds of copper sulphate, five pounds of lime, and 50 gallons of water. It is shown that bitter rot can be controlled by four applications of Bordeaux mixture if applied at the proper times and in a thorough manner. The first application should be made about five or six weeks after the trees bloom, followed by others at intervals of about two weeks. By this method the experimenter was able to save from 93 to 98 per cent of sound fruit on the trees, while on adjoining trees that were not sprayed the fruit was a total loss. In dry, cool seasons the intervals between the later sprayings may be increased, while in hot, moist summers the intervals should be shortened and the number of applications increased. If for any reason the spraying is not begun until after the bitter rot has made its appearance on the young fruit, the trees should be given at intervals of only a few days two thorough sprayings, to be followed by applications as described above.

By beginning the spraying with the swelling of the buds and following at intervals of about two weeks until about eight applications have been given the trees, attacks of apple scab, leaf blotch, and sooty mold may also be prevented.

†Compiled from Illinois Station Bulletin 77, Circulars 58, 67; Virginia Station Bulletin 142; U. S. Department of Agriculture, Bureau of Plant Industry Bulletins 44, 93 and Farm Bulletin 267.

Black Heart

The cause of this disease of the trunk is obscure. It may be due to too low a winter temperature, and again it may be the effect of the earliest invasion of fungal filaments. Possibly it is the result of some other general causes.

Black Rot, Canker, and Leaf Spot

Sphaeropsis Malorum Berk.

The three diseases given above have been found to be due to a single fungus, "*Sphaeropsis Malorum*." The black rot of the apple is very common in New

Hampshire. It is dark brown or black in color and the affected tissue comparatively firm. It is thus readily distinguished from the soft rots. It may start on any part of the fruit, but often begins at the blossom and frequently follows insect stings. The disease is primarily a rot of ripe fruit, but it may often be found as dark brown spots one-eighth to one-half inch in diameter several weeks before the apples are mature. These spots may develop very slowly until about picking time, but after that spread rapidly, involving the whole apple. As the rot develops, numerous minute, black elevations may be seen on the apple (Fig. 1). These are spore producing bodies of the fungus and are

known as pycnidia. The rot does considerable damage in cellar storage, but is especially common on the fruit left on the trees or ground. This worthless fruit becomes a source of infection the following spring.

Canker is a term applied to rough, unsightly wounds that are known to be due to the action of fungi. The most common variety of this trouble is the "black rot canker," also known as the "New York apple tree canker."* Both large and small limbs are attacked and

* Paddock, Wendell. The New York Apple Tree Canker. New York Agricultural Experiment Station Bulletin 163.
Paddock, Wendell, Ibid (Second Report), New York Agricultural Experiment Station Bulletin 185.



Fig. 1. Black Rot of Apple Due to *Sphaeropsis malorum*, Showing Black Rot on Fruit, Black Rot Canker on Limb, Early Stage of Leaf Spot (upper figure) and Late Stage of Leaf Spot (lower figure).

—New Hampshire Experiment Station.

sometimes the trunk. In some cases it seems to cause merely a greater roughening of the bark, but where a broken twig or other injury furnishes an entrance to the actively growing tissue of the host the effects are often much more pronounced. In serious cases the bark may be killed over considerable area and become conspicuously cracked and roughened (Fig. 1). It is set off from the living bark by a very definite boundary. Limbs are often so nearly girdled that the parts beyond die. Pycnida similar to those on the fruit are found on the canker.

Like the other diseases attributed to *Sphaeropsis Malorum*, the leaf spot is of general occurrence. The disease makes its appearance on the leaves shortly after they unfold from the bud. Infection continues throughout the spring, but notes taken the past two years indicate that it is uncommon after the middle of June. At first the spots are small, purple areas, but as growth progresses they become yellowish-brown in color and attain a diameter of from one-eighth to one-half inch (Fig. 1). They are quite uniformly circular in outline. The margins are somewhat elevated, giving to the spot a sunken appearance. As the spots become older a secondary growth may spread from the central affected area, producing a somewhat irregular blotch in which the outline of the original spot can always be recognized. (See Fig. 1.) It often happens that several of these areas become confluent, and thus the greater part of the leaf may become affected. Spotted leaves fall from the trees early in the fall and their working efficiency is always greatly reduced by the middle of the summer. Trees thus robbed of their foliage from year to year must eventually become greatly impaired in their vigor.

The cause of the leaf spot has occasioned no little difficulty. A number of fungi have been found to be present in the spots, but inoculation experiments have indicated that *Sphaeropsis Malorum* is probably the only one that is of im-

portance in the production of the disease.

Treatment

The fact that one fungus is responsible for three different forms of disease makes its destruction a matter of special importance and rather unusual difficulty. Spraying has been quite effective in controlling the leaf spot. In the summer of 1908 the per cent of leaves spotted in the orchards referred to under apple scab was reduced from 97 to 26 by the use of Bordeaux and to 21 by the use of lime-sulphur solution. Five sprayings were made, but it is probable that only the first three were effective for leaf spot. Sprayings made at various times in the summer have had little or no effect upon the number of spots of rot on the fruit at picking time. The destruction of the affected fruit seems to be the most efficient treatment for this form of disease. All cankered limbs should be cut out and burned. Large wounds should be protected by a covering of paint. Thorough spraying is of value in protecting the limbs. Heavy applications made when the trees are in a dormant condition are probably especially efficacious.

CHARLES BROOKS,
Durham, N. H.

Blackspot Canker or Apple Tree Anthracnose

Neofabraea Malicorticis (Cordley)
Jackson

BY W. H. LAWRENCE

*Plant Pathologist and Horticulturist for
Hood River Apple Growers, Hood
River, Oregon*

More than a decade has passed since Blackspot Canker or Anthracnose made its appearance in apple orchards throughout the Pacific Northwest and became so destructive that information concerning its control was sought. Although the cause and control of the disease has been determined and fully demonstrated the disease has been allowed to continue year after year in some of the orchards of each of the apple-growing sections. Continuous and scattering observations as

well as some more or less connected experimental work done by several persons in different localities and widely differing conditions show that the control of this disease is by far more important than suspected at an earlier date. It is now definitely known that the fungus has two stages, one of which may be termed the conidial and the other the ascigerous. Also that the fungus attacks the prune, plum and pear causing shallow cankers in the outer bark of the trunks and larger branches; will induce Gummosis of the cherry and in addition to the destruction wrought upon the apple tree, also causes the most serious loss of apples in both common and cold storage due to a fungus, as well as causing a similar decay of the fruit of the quince.

The recognition and control of the disease caused by this fungus which is now known under the scientific name of *Neofabraea Malicorticis* (Cordley), Jackson, is of greatest importance as a disease of the apple since the fungus attacks the body of the tree directly threatening the life of the plant and later produces spores which lodge upon the fruit causing serious losses of the fruit after it has been placed in common or cold storage.

The discovery that there are two spore forms developed in a canker and that the conidia mature the first year while the bark is dying or a little later and that the second year another crop of spores (ascospores) are thrown out, should make the orchardist doubly cautious in attempting to eradicate the disease since the distribution of spores continues for so long a period.

Thorough applications of fungicides during the autumn applied previous to the early rains of winter do control the disease. Owing to the late date apple harvesting continues, it is sometimes true that the autumn rains are heavy enough to make the soil so muddy that it is impossible to spray following the gathering of the fruit. Owing to the fact that tests with lime-sulphur and Bordeaux mixture made on mature fruit shortly before picking time have at least indicated that the fruit may be sprayed without the slightest injury, it seems ad-

visable to spray the fruit before gathering it. Such applications should control the spread of the fungus for a short period at least and kill all the spores of the fungus (anthracnose) adhering to the fruit as well as in part preventing the late infection of apple scab which sometimes takes place upon the fruit after the same has been wrapped, packed and placed in storage.

A thorough spraying with double strength Bordeaux mixture, applied in spring before the buds began to open, has also given the desired results. At this time the entire tree is exposed to the direct drive of the spray and the trees may be so thoroughly coated that the amount of spray that will adhere to the bark during the entire season is sufficient to give as good results as have been obtained through applications during autumn. This spring spraying admits of thoroughly soaking all the cankers which if in a dry condition have been observed to become a deep blue color, due to the dead bark absorbing large quantities of the spray.

In cleaning up a badly infested orchard the dead bark should be torn from all the cankers and as many of the new cankers scraped as practicable, after which one or more thorough sprayings, preferably with Bordeaux, should be made.

Black Spot Fungus or Scab

Fusicladium dendriticum

During recent years the apple scab fungus has been very troublesome in Canada, often injuring the fruit so badly that it is quite unsaleable. The disease attacks the tree in early spring and is first noticeable as light green patches on the young leaves. The fruit may be affected as soon as formed and if badly diseased will drop off. As the fruit increases in size the diseased patches enlarge and nearly all the surface is often covered with the black spots before the fruit is picked. In addition to the disfigured appearance of the fruit, caused by this disease, the apples do not reach their full size. The apple spot develops most rapidly in moist weather. This disease may be almost entirely prevented

by the proper use of Bordeaux mixture, the remedy recommended at the end of this paragraph. While a certain number of applications are recommended, more will have to be given if the season is wet. The object should be to keep the trees covered with the mixture from the first until the last spraying. If the mixture is washed off the tree the disease will have an opportunity of developing and it is difficult to check it, if it begins to spread.

Remedy

Spray with copper sulphate solution (one pound copper sulphate to 25 gallons water) or with Bordeaux mixture before the buds start, or when they begin to break; and with Bordeaux mixture, just before blossoms open; soon after blossoms fall and two or three times after at intervals of from 10 to 15 days. The first three sprayings are the most important.

W. T. MACOUN,
Ottawa, Canada.

Blight

Bacillus amylovorus (Burrill) De Toni.
FIRE BLIGHT, PEAR BLIGHT, TWIG BLIGHT. See under *Pear*.

Blister Canker

Nummularia discreta Tul.

The disease is sometimes known as "Illinois Canker," since it was first observed as particularly destructive in that state. It seems to be less destructive in New England than the black rot and European cankers. It has a characteristic appearance that readily distinguishes it from either of these diseases. (See Fig. 1.) It is usually found on the larger limbs, and sometimes attacks the trunk. Old cankers are often a foot or more in length. The fungus attacks the wood as well as the bark. In the early stages of the disease the bark is brown and slightly sunken and usually set off from the healthy bark by a distinct boundary. As the season advances circular fungous masses known as stromata develop on the diseased area. They are formed beneath the bark, but soon break through to the surface, furnishing the most characteristic feature



Fig. 1. Blister Canker of Apple. The bark has been removed from the upper portion showing the circular markings produced in the wood.

of the disease. The stromata are firmly fastened to the wood by means of a hard ring of fungous tissue, so that they remain attached to it even after the bark has fallen away. Summer spores are produced on the surface of the stroma. Later in the season, numerous flask-shaped perithecia are formed within the stroma, but opening on its surface. These produce many club-shaped asci, each containing eight spherical, brown spores.

Treatment

The fungus seems to be dependent upon wounds for entrance to the host tissue. The best method of treatment is found in avoiding unnecessary injuries to the tree and in the proper care of all wounds. All cankered limbs should be destroyed.

CHARLES BROOKS,
Durham, N. H.

BLOSSOM BLIGHT. See *Blight under Pear*.

Blotch

Phyllosticta solitaria E. & E.

The blotch is caused by a fungus which lives parasitically upon the fruit, twigs and leaves of the apple.

The apple blotch frequently causes over 90 per cent of injury to susceptible varieties in the Central West. It has been successfully controlled on the fruit, the first season sprayed, by the application of Bordeaux mixture.

By the continued use of Bordeaux during successive seasons the disease can be almost completely eradicated from the orchard in from four to six years. The 3-4-50 Bordeaux can be safely used, if made and applied only as recommended.

It is especially necessary in the control of this disease that the spraying be done with absolute thoroughness, and at the time indicated in the schedule.

Lime-sulphur solution is less effective than Bordeaux mixture, for blotch control, but should always be used during wet weather, on account of the tendency of Bordeaux to cause injury at such a time.

The work of eradicating the blotch fungus can be hastened, the chance for injury lessened, and the commercial value of the fruit increased, by carefully cutting back the affected trees.

This cutting-back process strengthens the framework of the tree, and throws it into vigorous growth. Advantage may be taken of this growth to increase and lower the bearing surface of the tree.

Recommendations

The apple blotch fungus can be controlled. In the most susceptible varieties, showing an enormous amount of cankers, the disease has been reduced to less than five per cent of injury by the application of Bordeaux mixture. It has been found that the disease on the fruit can be controlled the first season by spray applications, and that by following the same treatment during successive seasons it can be almost entirely eradicated from the orchard. This process can be hastened and the injury materially lessened by removing the worst cankered and useless limbs from the infested trees.

Bordeaux mixture frequently causes serious burning, and an investigation of the methods generally used in preparing

this mixture has led the author to the conclusion that three factors are largely responsible for this injury. First, a stronger mixture than necessary to control the fungi is ordinarily used; second, unsatisfactory methods are frequently employed in mixing; third, a poor grade of lime, or air-slaked lime, is commonly used. Investigations both in the laboratory and in the orchard have shown that three pounds of copper sulphate and four pounds of well-slaked stone lime for each 50 gallons of water make a Bordeaux which, for all summer orchard work, is effective and less liable to injure tender fruit and foliage than that made according to the stronger formulæ.

The Correct Method of Making Bordeaux

In order to make an effective Bordeaux, and one that is the least liable to cause burning, the copper sulphate and lime should be added each to one-half the total required water, and these two dilute solutions allowed to run together, in equal quantities, into a third tank. There is nothing new about this method, as it has been in use for years, but ordinarily the beginner tries to lessen the time and labor involved in this process, with the result that serious injury follows. The manner in which these two solutions are mixed may be varied according to convenience, just so the two are mixed in equal dilute quantities. Very frequently, when small amounts of Bordeaux are required, the two dilute solutions are poured together into the spraying tank by hand. When large quantities are to be made, however, two tanks, each large enough to hold a little more than one-half the volume of the spray tank, should be placed upon an elevated platform at such a height that they will drain into the top of the spray tank. The two dilute solutions are then made in these tanks and allowed to run together through equal-sized openings into the spraying tank.

Much care should be taken in slaking the lime used in Bordeaux mixture. It should not be entirely covered with

water, but only enough water added to carry on the process without burning. After the slaking process is over, the lime should be thoroughly mixed with water until a milky fluid is obtained, when it is ready to add to the required amount of water to bring the total volume up to one-half the water named in the formula.

The copper-sulphate solution is best dissolved by placing a known weight of the material in a burlap sack and suspending it in the top of a barrel or tank of water. If 100 pounds are dissolved in 50 gallons of water, 1½ gallons of the stock solution will be required for making 50 gallons of Bordeaux by the 3-4-50 formula.

The 4-4-50 or 5-5-50 formulæ are not to be advised for summer spraying, as serious burning is liable to follow their use.

Spray Schedule

First Application — Apply Bordeaux, 3-4-50, as a mist three weeks after the falling of the petals. In case of wet weather substitute lime-sulphur for Bordeaux. Apply Bordeaux as soon as the weather will permit.

Second Application.—From two to four weeks after the first application apply Bordeaux, 3-4-50, again as a mist. Use lime-sulphur if the weather is wet. Apply Bordeaux as soon as the weather will permit.

Third Application.—Apply Bordeaux as in the previous applications, 10 weeks after the petals fall.

By adding arsenate of lead at the rate of two pounds to 50 gallons of the fungicide, any of the above materials may be made to assist in the control of insects. Such a combination adheres to the fruit and foliage better than the fungicide alone. During an extremely hot, bright spell of weather the lime-sulphur-lead combination frequently causes burning, but during such weather it is advisable to use Bordeaux rather than lime-sulphur.

References

Ellis & Everhart. Proceedings of

Academy of Natural Sciences, Philadelphia, 1895.

Clinton. Illinois Agricultural Experiment Station, Bulletin No. 69.

Scott & Quaintance U. S. Department Agriculture, Farmers' Bulletin No. 283.

Scott & Rorer. Bureau of Plant Industry, Bulletin No. 144

Sheldon. Science N. S. 26, No. 658; August 9, 1907

D. E. LEWIS,
Manhattan, Kan.

Blue Mold Decay

This is the rot of apples which is caused by the common blue mold which is familiar to everyone on preserved fruits, jellies, etc. Blue mold grows as a saprophyte on a large number of dead organic substances and produces large numbers of spores so that the spores are practically everywhere present and may start a new growth of the mold whenever they fall upon a substance which furnishes a suitable food supply provided that the temperature is favorable for growth.

This decay of apples is probably caused by more than one species of this genus. In some cases other fungi aid in the decay but since *Penicillium* breaks out and shows more prominently on the surface of the apple, it is often held responsible for more of the decay than it causes. There can be no doubt, however, that one or more species of *Penicillium* cause a large amount of the soft rot of stored apples. This is primarily a rot of ripe apples and does not cause decay of green fruit. The threads of the fungus cannot penetrate the uninjured epidermis of the apple but must gain entrance through injured places such as bruises, cuts, cracks, worm holes, spray injured places or scab spots. It spreads rapidly in ripe apples and complete decay takes place in one or two weeks. The tissues become soft and are light brown in color. Little tufts of mycelium which bear the spores break out on the surface of the decayed region. These tufts soon become light blue or blue-green, later gray-green to brownish

in color. Apples rotted by this fungus take on a characteristic moldy odor and taste.

Since the fungus enters the apple through wounds, any means of control of the rot must look to the prevention of injuries to the epidermis. Care must be taken to produce good, sound apples and then these should be picked and handled in such a way as to avoid cuts and bruises. The apples should be stored where the temperatures are as low as can be maintained with safety from freezing.

W. J. MORSE,
Orono, Maine.

BODY BLIGHT. See *Blight under Pear*.

Botrytis Decay

A species of *Botrytis* causes a part of the decay of apples in Maine. It has been found causing a rot of early apples on the tree and inoculations have shown that it not only attacks ripe fruit but that it is capable of causing a rot of green apples. The fungus spread rather rapidly in the tissues of winter apples which were inoculated early in August, so that in two weeks one-half of each apple was decayed. It causes a rapid and complete decay of ripe apples.

W. J. MORSE,
Orono, Maine.

Brown Rot

Sphaeropsis malorum

See *Black Rot*.

Brown Rot

Sclerotinia fructigina

Soft rot. Ripe rot. Same as brown rot of plum. This fungus is everywhere present. The least break in the skin gives it easy entrance into the fruit. Loss of fruit in storage from this disease follows when the skin is cut by finger nails or punctured by fruit stems or broken in any way.

Pick the fruit with stems on. In wrapping and packing, do the work in such a way that there will be no puncturing by stems. Protect from injury by insects and diseases by spraying, as for scab.

Rainy weather late in the season after prolonged drought may cause growth

cracks in the fruit through which this fungus may gain entrance to the flesh. To avoid this, maintain uniform rate of growth by thorough tile drainage and by early and frequent cultivation to conserve the soil moisture and keep the skin of the fruit in active growing condition.

S. A. BEACH,
Ames, Ia.

Brown Spot or Dry Rot of Baldwin

Very frequent complaint is made of small sunken spots in fine specimens of Baldwin and some other varieties. Internally these sunken spots are dry and somewhat bitter, leading to general breakdown of the apple. These spots have been referred to a particular fungus (*Phyllachora pomigena* [Schw] Sacc.), but the case is not proved. This internal brown spotting also occurs in Northern Spy and in Fameuse. The causes of the internal spotting are probably the same in all cases and must in part be regarded as physiological breakdown. New Hampshire Experiment Station (Bulletin 45) succeeded in controlling the form of this dry rot on Baldwin by the use of Bordeaux mixture. Some irregularity in results from spraying for it have been recorded elsewhere.

A. D. SELBY.

Calix Injury

Sometimes thought to be occasioned by sprays applied under unfavorable conditions.

Canker and Twig Blight

The term canker has become such a general one as not to admit of easy definition. It is commonly used to describe the condition of branches of trees in which an area of bark has been killed and has broken away so that a portion of the wood is laid bare or is covered only by cracked and roughened bark which does not protect the wood. In the writer's opinion the term "canker" as applied to diseased areas on trees should be restricted to those characteristic lesions on the trunk and limbs which are the result of alternate attempts to heal, with the formation of

new wood, followed by further killing of the living tissue. In early stages of development, cankers show a region of sunken discolored bark and it is only in later stages that the bark breaks away. Cankers have been described as caused by frost, sun scald, fungi, and bacteria. A considerable number of different fungi have been reported as causing canker of apple trees in different parts of the United States. These vary greatly in the amount of damage which they do in different regions. In some cases, a fungus which causes a great amount of injury to the trees of one region occurs rarely or not at all in another region.

Frost Canker

Much of the disease of apple trees which orchardists have been calling canker has its origin in severe winters. Some injuries so resulting might be properly classified under the term "frost canker." On the other hand, when whole trees are so badly injured that they die either that year or the year following, the injury is too widespread and acts too quickly to be regarded as canker. There are a number of forms of winter injury and the frost canker is only one of them. The frost canker is a local injury which tends to heal over under favorable conditions for growth unless the new growth is killed by another period of low temperature before it has become hardened. In this way the frost canker may spread, or in other cases the injured bark may serve as a place for the entrance of a parasite which may then spread in the bark and outer layers of wood and kill a rather large area in a single year.

So far as they have been investigated it has been found that the organisms which cause canker of fruit trees are, in a large measure, wound parasites. They are unable, as a rule, to penetrate the uninjured bark but must enter through wounds. In this sense, the places injured by freezing serve the same end as wounds of any other kind. However, it may be pointed out that cankers caused by fungi do not spread

so rapidly as to kill trees in the short time which has been observed in the case of winter-killed trees. In the case of young trees the fungus may in some cases girdle the tree in a few weeks and thereby cause its death. The same holds true of small branches of old trees, but in the case of large branches the fungus usually spreads but a few inches each year forming true cankers, and the rough, blackened areas that are frequently seen on large branches often represent a development of several years. The living tissues attempt to heal over the wound by the formation of callus and in some cases with considerable success. Often the parasite ceases to spread in the bark when the dry season of summer comes on and a crack forms between the healthy and diseased bark. The following year the diseased area may continue to spread or the callus may check it considerably. Often other fungi, some of them saprophytes, grow upon the dead bark.

There are many other wounds than those caused by freezing through which parasitic fungi may enter. By this it is not meant that every wound that is made in the bark will necessarily become infected and develop into a diseased area. In many cases, however, the spores of parasitic fungi are carried to wounds. This is especially liable to be the case when diseased branches are allowed to remain on the trees, or old neglected trees in the neighborhood produce abundant crops of fungus spores from year to year. Some of the ways in which wounds are made are: Bark-ing of trunk and branches by machinery in cultivating and caring for the orchard; injuries by ladders and by men in picking fruit; branches are sometimes injured by props used to support a heavy load of fruit especially when they are carelessly placed in position; in some cases hailstones split the bark of small branches. Care should be taken to avoid any injury which is within the control of the orchardist. Wounds are sometimes kept from healing over by the woolly aphid which forms little cot-

tony patches in wounds and, by delaying the healing over process, makes a favorable place for the entrance of a parasitic fungus.

Amongst the fungi which are responsible for cankers in various parts of the country are: Bitter Rot fungus (*Sphaeropsis malorum* Pk.), *Myxosporium corticolum*, Edg., *Coryneum foliolum*, Fckl., *Phoma mali*, Schulz and Sacc., *Cytospora* Sp., European Apple Canker (*Nectria ditissima*, Tul.) and *Nummularia discreta* Tul.

Closely associated with canker caused by fungi is the killing back of small branches and twigs caused by the same organisms. In searching orchards for cankers we have found this dying back of the branches and water-sprouts much the more common of the two. The fruiting bodies of the same fungi have been found on both, and cankers on larger limbs have been found repeatedly which apparently started from the disease following back on a smaller branch or twig. Inoculations with canker producing fungi early in the spring show that they are capable of killing the young twigs very rapidly and run back a considerable distance in a single season. A twig blight may be caused by the pear blight bacillus.

In many ways the dying back of small branches is like the development of canker. The fungus may spread back only a short distance each year for a number of years or the spread is rapid and the branch is killed back a considerable distance in a single year. It is probable that in many instances the young wood is injured by freezing and the fungi gain entrance in this way. We have observed the same thing where young nursery stock has become infected through wounds made in cutting back when set. Twigs and limbs affected in this way should be cut off well below the diseased portion and the wounds protected from further infection.

Sphaeropsis Canker

The canker caused by the black rot fungus, *Sphaeropsis malorum* Pk., is

widely distributed. This disease is known as the "New York Apple Tree Canker," because it was first described from New York. This fungus causes the black rot of the fruit and a leaf spot as well as the disease of the wood.

See *Black Rot*.

The fungus attacks either young or old branches and the amount of damage depends on the amount of bark and adjoining surface portions of the wood which is destroyed. In some cases a branch may be girdled in a short time and death of that branch results, but in other cases the canker spreads for years on one side of the branch before it is completely girdled. The other side of the branch in such a case may become somewhat enlarged.

To control this canker, the orchardist should remove all dead branches, and all old neglected trees such as one frequently sees along the roads, and burn them. Branches which show bad cankers should be cut off back of the canker and burned. In the case of young cankers, the branch can frequently be saved by cutting away the diseased tissue down to healthy wood, disinfecting with a solution of copper sulphate, one ounce to one gallon of water, or corrosive sublimate, one part to 1,000 of water, and then painting over with pure white lead in boiled linseed oil or coating with a good quality of grafting wax. The trees should be gone over carefully a number of times each year and developing cankers and wounds should receive attention. Spraying for apple scab will help to control the cankers by reducing the amount of material for infection and by covering wounds with the fungicide. All decayed fruit should be destroyed, since the black rot of the fruit and this canker are caused by the same fungus. The treatment outlined should go far toward controlling cankers caused by other fungi.

Bitter Rot Canker

This canker is caused by the fungus which causes bitter rot of the fruit. On the dead bark the fungus produces little black pustules from which, when they

are mature, pinkish masses of spores exude. The spores from cankers cause much of the early infection of fruit on the tree each year.

Myxosporium Canker

The fungus causing this disease has been much confused in the past with *Sphaeropsis malorum*. The two are entirely distinct. So far as observed the damage which it does is confined to killing outer portions of the bark on old limbs and the killing back of the bark on younger limbs and twigs rather than to the production of true cankers. On such branches the fruiting pustules are found on the part which was first killed. The dead bark is separated from the healthy bark by a sharp line and is sunken. The appearance of these branches is very characteristic and they can be recognized by one who has become somewhat familiar with the various cankers and twig blights, without microscopic examination of the fungus. There is some reason to believe that the fungus is not a very active parasite and it may be possible that such diseased branches have been injuriously affected by some other agency before the attack of this fungus.

Coryneum and Phoma Cankers

In the examination of apple cankers the spores of *Coryneum foliicolum* and *Phoma mali* have been found of quite frequent occurrence. Inoculation experiments have proved that both of these fungi were capable of causing disease of healthy bark of apple branches. For a detailed account of the study of these fungi the reader is referred to Bulletin 170 of the Maine Station.

Cytospora Canker

A species of *Cytospora* has frequently been found on small branches which have been killed back but no true cankers have been seen. Those lesions observed have much the same appearance as has been described for branches on which *Myxosporium* is found. After a little experience one can distinguish the two fungi on the bark without the aid of the microscope.

Pear Blight Canker

The canker of apple trees caused by the pear blight organism, *Bacillus amylovorus* (Burril) DeToni., has been reported as causing a great amount of damage in apple orchards in various states.

See *Pear Blight* under *Pear*.

W. J. MORSE,
Orono, Maine.

CLUB TIP. See *Rosette*.

Collar Blight

A form of pear blight attacking the apple at the thickened portion of the tree just above and below the ground line.

See *Pear Blight* under *Pear*.

Some forms of collar disease are the result of winter injuries followed by the entrance of fungus disease.

COLLAR ROT PHASE See *Blight under Pear*.

Core Decay of Baldwin

A core decay of stored apples was investigated by H. J. Eustace, of the New York Experiment Station, in 1903. This decay occurred quite generally in Baldwins but was not confined to that variety.

The apple shows decayed tissue about the core, which is brown, dry-rotten and tasteless, but surrounded by healthy tissue.

The trouble was not traced to any fungus or bacterium. It appeared under a variety of soil conditions. The Baldwins that year overbore and storage conditions may have been responsible for a part of the trouble, as only common storage apples seemed to be affected.

Crown Gall

Bacterium tumefaciens

H. P. BARSS

Crown gall is a very common and widespread disease known under a variety of other names such as "galls," "tumors," "root knot," "crown knot," "woolly knot," "hairy root," etc. It has been reported from every state in the Union and from Canada, Europe, Africa and Australia as well. It attacks the apple, prune, peach, cherry, raspberry

and many other cultivated and wild plants, herbaceous as well as woody. It is very common on members of the rose family (*Rosaceae*) to which all of our ordinary tree fruits and many of our small fruits belong. Besides the plants above mentioned, it is reported as attacking the grape, walnut, chestnut, poplar, willow and alder. In the Northwest it is known on practically all of our tree fruits, is found on blackberries, raspberries, loganberries and grapes, and also on the hop. The usual effect upon these different hosts is the production of tumors or galls, which are in general



Fig. 1. A, Crown Gall on the Canes of Grape. B, Crown Galls on the Peach Root of a Prune Tree. C, Crown Gall on a Loganberry Root.

somewhat similar in form and appearance. The galls, as a rule, have an annual development, that is, they begin to form in the spring as the tree starts active growth and cease development in the fall. At first they are small, nearly spherical masses of more or less succulent tissue, whitish or translucent in appearance but rapidly becoming darker and uneven, till at maturity they are dark brown and warted. When occurring on small roots they may be only about one-quarter inch in diameter, while

on nursery stock, raspberries, etc., they may be about the size of a walnut. On large trees in the orchard they may reach a much greater diameter. The galls usually occur at the base of the trunk or on the roots, though in some plants they are found on the stems or branches above ground. The most common point of attack, however is just beneath the ground at the crown of the plant. A peculiar form of the disease known as hairy root occurs commonly on the apple.

The effects of an attack of this disease are much more serious on certain kinds of plants than upon others and even among individuals of the same kind there are wide variations in the resulting amount of damage. In some cases trees may be affected without giving any signs of harmful effect upon growth or production of fruit. In other cases, trees or smaller plants are often stunted and unprofitable and not infrequently die as a result of the presence of the galls. There are also many well-authenticated instances where trees known to be badly affected with crown gall have experienced apparently complete recovery. Furthermore, some of the serious ill effects attributed to this disease must often, on careful investigation, be charged to other troubles which have had entrance through the unprotected or decayed gall. The fire blight bacteria, mushroom root rot, wound parasites and heart rot fungi of various sorts as well as certain insects have easy access to a tree through galls where a healthy bark would have prevented any attack, and in most cases these secondary intruders are liable to have more serious consequences for the tree than the mere presence of the gall. It is supposed also that the disease may appear in severe or in light form, depending upon the virulence of the strain of organism producing the infection.

The detrimental effect of the crown gall itself may arise in several ways. The tumors rob the plant of some nutriment. Excessive evaporation of moisture may occur from the unprotected gall surfaces, especially where aerial galls are abund-

ant on slender stems. The galls may also interfere with sapflow and the decay of soft galls usually involves adjacent healthy tissues producing serious wounds or in some cases girdling the stem with death of the plant as a result. One of the worst effects of the disease is the frequent prevention of normal root development resulting in the failure of a young tree to establish itself or in the retarding of its growth.

Cause

Crown gall has been known and recognized as a serious disease for many years. Until comparatively recently, however, the cause was unknown. The careful experiments begun in 1904 by Smith, Brown and Townsend, of the United States Bureau of Plant Industry, have proved conclusively that the disease is caused by a bacterium, under the name *Bacterium tumefaciens*.

The bacterium causing crown gall is an organism which can exist in the soil. It seems to be widely scattered in many soils, but appears especially abundant in nurseries and in land where plants affected with crown gall have previously been grown. Plants in a young, tender and rapidly growing condition, are most subject to infection, whereas older and more mature plants are not so frequently attacked. The wounds made in root-grafting and budding offer a favorable point of entrance for the germs, and injuries to the underground parts of plants by cultivation, attacks of borers, etc., render them susceptible to infection. In fact, the organism may be considered a wound parasite.

The Effect of the Organism

In order to cause infection the bacteria must enter into some part of the plant where new cells are in the process of formation. They make their way into the living cells and stimulate them to abnormal and very rapid multiplication. Cells near those containing bacteria may perhaps be stimulated in the same way. The number of bacteria in any one cell is not large. They multiply slowly and do not appear to injure the cell to any great extent, but merely to stimulate rapid di-

vision. When a cell containing bacteria divides into two, each of the daughter cells contains some of the bacteria and hence will be stimulated to rapid multiplication. Thus, as a result of the presence of the bacteria, there is formed an abnormal mass of rapidly growing tissue in which the elements become distorted and twisted. It is an unnatural, wasting growth, in no way adapted to the needs of the plant. Such galls or tumors vary greatly in form, size and consistency, depending apparently upon the virulence of the particular germ causing the infection, the kind of plant or variety which has been attacked, the particular tissues which were first infected, etc. Even individual plants of the same variety show great differences in susceptibility to this disease.

The Soft Gall

One of the commonest forms of crown gall especially on herbaceous plants and cane fruits, is the fleshy form in which the outgrowth is somewhat soft. These grow rapidly and are not protected by a bark or corky layer. Growth usually commences in the spring (sometimes earlier). After a few months of development the outer layers of the gall begin to die and are attacked by various bacteria and fungi. This generally ends in the decay and sloughing off of nearly the whole tumor by the end of the season. The margin of the gall, however, usually remains alive and during the next season the tumors grow out again, followed as before by decay. When the gall dies some of the healthy substance of the plant is usually killed and a wound is formed which renders the entrance of other diseases easy. Galls are known to die off completely in some cases at the end of the first or second season, while the plant recovers; but commonly the tumors reappear from year to year.

The Hard Gall

Not all galls are of this soft type, but many are very hard and woody, in which case the growth is apt to be slower and the gall persists longer—often for many years. The exterior may develop a bark-like covering and instead of a rapid decay

at the end of the season, there is often little or no disintegration and the gall increases in size as new growth is added each season. In time, however, the surface of the hard gall usually suffers disintegration to some extent. Between the softest and the hardest galls there are many transitional forms and soft galls often develop a woody structure and become persistent.

Hairy Root

In the apple, and in some other plants, there is a very common trouble known as hairy root. This is produced by the same organism that causes other forms of crown gall. In typical hairy root there is no large gall formation, but there appear on the main roots or on the crown clusters of numerous, succulent, abnormally fleshy rootlets which generally project nearly at right angles. When dry these rootlets shrink and become hairy in appearance. Bacteria are not found in the abnormal rootlets but in the flattened and often inconspicuous tumor from which they arise. Hairy root is not found to be entirely distinct from other types of crown gall. The tumors on certain plants frequently produce abnormal rootlets and the aerial hard gall of the apple will often develop roots when subjected to moist conditions. Furthermore, the organism isolated from hairy root is capable of inducing the formation of typical galls as well as hairy root when inoculated into different plants.

Tumor Strands and Secondary Galls

The interesting discovery has recently been made that in certain plants strands of tumor cells may push out from the primary galls, and working through certain easily penetrated tissues, may reach distant parts where by rapid multiplication of the tumor cells new galls are formed which burst out from the parts of the plant thus invaded. Much of the severe breaking out of galls along the canes of some of our small fruits and of grapes may eventually prove to be secondary growths of this nature.

Modes of Infection

It seems probable that the disintegration which the crown galls usually under-

go sets free the disease-producing bacteria contained in them, and as a result the soil becomes infected. It is common experience that soil infection is responsible for large nursery losses every year. Nursery conditions are particularly favorable to the transmission of the disease. Trees are planted close together. They are in the earliest stages of rapid growth and hence in the most tender and susceptible condition possible. The disease develops principally during the first year or two and is said to gain entrance almost entirely through wounds or as a result of root-grafting or budding. Budded trees are not so liable to infection as grafted trees, while root-grafts made in a careful manner* result in less gall formation than grafts carelessly made. Ground infected by the presence of diseased trees will prove capable of transmitting the disease to young trees set later in the same ground and cultivation, spreads the trouble along the rows, while careless cultivation causes wounds which afford opportunity for the entrance of the bacteria. A large amount of infection is also possible where trees are heeled into soil that has previously covered galled nursery stock.

Trees may also become infected from the soil after being set out into the orchard. This frequently occurs with the stone fruits but not very commonly in the case of the apple. Most of the crown gall in our orchards, however, is due to the infection of the trees while in the nursery. There seems to be little evidence that infections spread from one tree to another in most apple orchards. Where berries, however, are set close together, serious spreading of the disease from plant to plant, has sometimes been recorded.

Cross Infection

While at present the limits of cross infection with different strains of the crown gall organism are not definitely known, yet we do know that crown gall bacteria

* For suggestions regarding methods of grafting and nursery practice refer to Dr. G. G. Hedgcock's recommendations in the Bureau of Plant Industry, Bulletin 186, U. S. Department of Agriculture, Washington, D. C.

isolated from several kinds of plants have proved easily cross-inoculable artificially to numerous other species in different plant families. More than one orchardist has also had practical proof of cross infection through contaminated soil. Consequently wise growers will hesitate to risk the chance of transmitting crown gall from one kind of cultivated crop to another by planting susceptible varieties in ground from which plants diseased with crown gall have recently been rooted out.

In the following paragraphs we give some information regarding the character and seriousness of crown gall as it appears on some of the more important cultivated fruits:

The Apple

Upon seedlings and root-grafted trees in the nursery we find principally the hairy root condition or galls of a somewhat fleshy nature. (See Fig. 2, A and B.) On older trees the persistent perennial hard galls are more frequent and in the orchard there appears also upon the

trunks and branches an aerial form of the disease. Aerial tumors are rarer than the root or crown form in most localities. They are characterized by the growth of smooth, woody, persistent swellings, which later become warty from the appearance of numerous stubby roots which break out just to the surface. It is not possible for us to state at present exactly how these aerial tumors originate, but the causal organism is similar to that producing other forms of crown gall.

Crown gall and hairy root are very prevalent in the nurseries, and because of laws forbidding the sale of trees affected with this contagious disease, the annual loss to nursery men is very large. Unscrupulous dealers sometimes cut off the galls and sell the trees, but tumors may reappear on such trees. Certain precautions may be adopted, however, in the care of young trees and in the methods of grafting which will reduce greatly the amount of disease in the nursery.†

† See Bulletin 168, Bureau of Plant Industry, U. S. Department Agriculture.



Fig. 2. A, Crown Gall on Young Apple Tree. B, Hairy Root on Young Apple Tree.

There have been great differences of opinion regarding the amount of damage resulting in the orchard from planting diseased trees. Some writers have claimed that affected trees never become profitable and that great losses occur among them. Undoubtedly the effects of more serious maladies such as root rot which may affect galled trees, have often been confused with crown gall injury. Careful investigation shows that the effects of the disease in orchards are not as serious as some have supposed. Loss does frequently occur, however, since galled trees are more liable to die the first year or two in the orchard than are unaffected trees. Many trees, on the other hand, seem to recover completely and grow into vigorous and profitable maturity. The writer has seen cases, however, where trees of bearing age were evidently stunted and unprofitable because of the growth of hairy root or crown gall on the roots. The orchardist is urged, therefore, to set the healthiest trees obtainable. If for any reason it is deemed advisable to set out diseased trees, galls and hairy root should not be cut out as the effect of the crown gall is likely to be less injurious than the results of such wounds made when the tree is young. If an old tree affected with crown gall appears healthy and is profitable, it is not recommended to remove the tree or to cut off the galls, since there is little danger of the disease spreading seriously in an orchard and cutting out frequently results in greater

damage to the tree than the presence of the tumor. If, however, a tree is rendered unprofitable, it had better be removed, although the grower might try thorough cutting out of the galls and disinfecting and painting over of the wounds, a method which is rarely a complete success as it is ordinarily practiced. In districts where fire blight is prevalent, it has been found that crown galls afford peculiarly favorable points of entrance for the bacteria causing the blight, much damage having frequently resulted in this way. In such districts, therefore, it is recommended to remove a strip of bark an inch wide around the base of the gall and then cut out the entire gall, being sure to remove every portion of it. The exposed surface should then be washed with a solution of corrosive sublimate.

Stone Fruits

Of the stone fruits the peach is most frequently mentioned as seriously affected by crown gall. It would appear that crown gall has usually a very much more disastrous effect on peach trees than upon apples. The root system is often so affected that the diseased tree cannot establish itself in the orchard, or, succeeding in that, fails to become vigorous and profitable. Never plant a galled tree. Prunes are known to be affected with the disease, but most of the cases on trees grafted on peach roots. Cherries and other stone fruits are also subject to attack. Cases of recovery from crown gall



Fig. 3. Crown Galls on a Loganberry Stalk.

are known to occur among stone fruits as well as among apples.

Small Fruits

Raspberries, blackberries, loganberries (Figs. 1 C and 3) are often affected with crown gall and probably other small fruits are also attacked. The disease not only causes galls on the roots, but on the blackberry, at least tumors often break forth in long lines from the interior of the canes. A case of what appeared to be hairy root on blackberry was sent to the Department of Plant Pathology during the summer of 1912. Considerable damage seems to result from the effects of the disease on these fruits and it is probable that soil infection and the spreading of the bacteria through the ground to healthy plants is much more serious than among orchard trees. Fruit trees should never be set immediately upon ground from which galled berry bushes have been grubbed out

Grapes

Most of the European varieties of grapes are quite susceptible to crown gall, while only a few of the American varieties are considered susceptible. On the grape the disease is found in two forms, as a root gall and as a cane gall. On cuttings and young plants the root form is most commonly found. These root galls are usually formed at a wound and consequently occur frequently at the graft union on grafted vines. On older plants the disease usually also attacks the stem extending from the crown upwards. On the canes the galls are usually confluent and occur in lines running lengthwise of the stem. The effect of the galls is to stunt the vines. The leaves are frequently smaller and show poor color. The underground galls decay each year and other rot-producing organisms may gain entrance and aid in finally bringing about the death of the vine. The cane galls are reported commonly to start from infection in frost cracks. They may also start in wounds made by pruning or in any other way. The disease is spread in the vineyard in various ways, such as by

the water of irrigation, use of diseased cuttings and by insects

No cure is known for plants that are already diseased and no definite recommendations can be made for the grower of European grapes. It is suggested, however, that where the disease is prevalent, it would be worth while to try out experimentally some of the stocks recommended as resistant under more southern conditions in the United States with a view to using such as may prove hardy. In New Mexico, where crown gall has been very serious, the Rupestris St. George, Sweetwater, Seedless Sultana, Matosa and some others are found resistant and succeed on their own roots. Benefit has also resulted in the south from grafting the susceptible varieties on such resistant stock as the Rupestris St. George and Lenoir. Among the most susceptible varieties are the Mission, Muscat of Alexandria, Flame Tokay, Malaga and Rose of Peru.

The following precautions should be taken whenever susceptible grapes are grown: Secure cuttings where possible from vineyards free from disease. Where frost is troublesome and infection occurs in the resulting frost cracks, plant deep or protect with some covering. It is best for the grower by propagating his own stock to avoid the possibility of introducing crown gall through grafts or cuttings from infected districts.

Hops

Crown gall is reported as serious on the hop in some sections. Affected plants should be removed and burned.

SUMMARY

The Disease

1. Crown gall in its various forms, which occur on a great variety of plants in many parts of the world, is caused by parasitic bacteria which enter the living cells of the host and stimulate them in some way to multiply excessively, thus producing tumors, the presence of which is usually detrimental to the welfare of the plant.
2. The greatest losses resulting from crown gall occur in the nurseries where

the soil becomes contaminated and the trees in their young and tender condition are particularly susceptible to infection through wounds and at the union of stock and scion in root-grafts.

3. In the orchard the effects of the disease are sometimes severe and sometimes slight, depending on many conditions. Apples do not suffer so much damage as do peaches, berries and other fruits. An attack of crown gall is usually detrimental, often serious, and sometimes fatal. A good many affected trees, however, recover or become resistant to the disease. There seems to be little spreading of crown gall in most orchards.

The Control

4. In order to keep crown gall under control in the nursery, trees or small fruits should never be grown in land previously infected with the disease. Such plants as become infected should not be allowed to remain in the soil until the galls decay, but should be removed and burned. Neither root nor scion used in root-grafting should come from stock having galls or hairy root, and the grafting and wrapping should be carefully done.

5. All nursery stock should be carefully inspected and all trees showing evidence of crown gall and hairy root or previous cutting-off of galls should be discarded. Fruit inspectors should use care in inspecting stock and make sure that every tree condemned is really affected with crown gall or hairy root. All warty appearances are not necessarily crown gall nor are all fibrous roots necessarily hairy roots. A whole shipment should never be condemned because a few trees are infected, since investigation has shown that there is little or no danger of infection spreading from diseased trees to healthy stock in the same shipment.

6. Growers should never plant a diseased tree. It is better to discard an affected tree than to run the risk that it will never pay interest on the spot of ground it occupies.

7. Trees which are found affected with crown gall in the orchard should be al-

lowed to remain if still profitable, but if unprofitable should be removed. Recovery sometimes results from the complete removal of galls with sterilization of the wounds. Cutting out is recommended, especially in fire blight districts, since galls afford favorable points for blight infection.

8. On account of the great difference in susceptibility of different varieties, a good opportunity is presented in the direction of the selection and breeding of resistant or immune varieties among fruits like the raspberry and grape, and possibly also among some of the tree fruits.

Bibliography

- 1905. U. S. Department Agriculture, Bureau Plant Industry, Bulletin 90, part 2.
- 1910. U. S. Department Agriculture, Bureau of Plant Industry, Bulletin 183.
- 1911. U. S. Department Agriculture, Bureau of Plant Industry, Bulletin 213.
- 1912. U. S. Department Agriculture, Bureau of Plant Industry, Bulletin 255.
- 1912. California Experiment Station, Bulletin 235.
- 1913. New Mexico Experiment Station, Bulletin 85.

Crown Gall and Legume Inoculation

The crown gall organism has been found in tumors somewhat resembling the normal nitrogen-fixing nodules upon the roots of alfalfa, crimson clover, and alsike clover. For this reason great care should be taken in using soil or cultures for inoculating legumes in regions which may sometime be used for sugar beets or for orchards.

It is usually possible to distinguish between the two forms of nodules by their external appearance. The nitrogen-fixing nodules appear to be an outgrowth of the root itself and has no more affect upon the root than any natural outgrowth. The interior of the nodule contains flesh colored cells full of bacteria. On the other hand the crown gall tumor causes much distortion of the root, frequently forcing it to branch in many small rootlets which

project from the tumor itself. The interior of the tumor is white.

It is not known what other leguminous crops are susceptible to crown gall. It is believed, however, that there is reason to suspect all of the clovers.

(See Circular 76, Bureau of Plant Industry.)

***Cylindrosporium Fruit Spot**
Cylindrosporium pomi. Brooks

Occurrence and Symptoms

The disease is of common occurrence in New England and is found in New York, Michigan, Ontario, and probably in other sections of the United States and Canada. The Baldwin is especially susceptible, but nearly every New England variety is more or less affected.

The disease appears about the middle of August as minute spots or specks on the surface of the apple. At first these are indicated merely by a deeper red color of the skin, if situated upon the colored part of the fruit, or by a green color, if situated upon the lighter portion. As the apple ripens the spots enlarge and many of them become brown and sunken, giving the fruit an unsightly appearance which often greatly depreciates its market value. The tissue beneath the spots is dry and brown.

The Fungus

The first studies upon this disease seemed to indicate that it was not produced by a fungus, but recent studies have demonstrated the causal relation of a fungus which seems to be properly a species of *Cylindrosporium*, as the title suggests.

Infection probably takes place in July or August when the stomata are being torn open and the protecting layers of the lenticles are not yet formed, a season when the metabolism of the apple is extremely great and the transpiration stream necessarily large.

Control

The disease is readily controlled by spraying with Bordeaux, and weaker fungicides are often very effective. Sprayings

* See Duggar, Fungus Diseases of Plants, p. 341.

made as late as July have been found to entirely prevent the disease.

CHARLES BROOKS

COLLAR ROT. See *Sun Scald*.

Coryneum or Orange Leaf Spot

Coryneum follicolum

Has a central, erumpent pustule with an immediate border of orange yellow; this yellow area shades off into dark color toward the green tissue. Hartley has reported, upon investigations of the fungus in this case, that it is not actively parasitic. Possibly we have this fungus following something else, after the manner that another fungus follows the black-rot leaf spot.

See *Rust of Apple*.

A. D. SELBY,

Wooster, Ohio.

DIE BACK. See *Rosette*.

Dropping of Apple Leaves

Many leaves drop from apple trees in summer and cause anxiety to fruit growers. Probably the three most important reasons why the leaves drop are: First, that the tree may regain a proper balance between top and root. There is often a great leaf development, owing to moist conditions, and when drier weather comes, there are too many leaves for the tree to support, hence some of them drop off. Second, that under certain conditions, especially when there has been a wet season, leaves will scald and drop off. Spraying sometimes causes this scalding. Third, that the leaves are affected with a leaf spot disease. The development of this disease may, however, come after they become weak from lack of moisture to support them, or when the leaf is weakened by sun scald. As a rule, under good cultivation, there are quite sufficient leaves left to develop the fruit properly.

Dry Rot

This is a disease which affects the fruit and is indicated on the exterior of the apple by small circular depressions. When the skin is removed, dryish, brown tissue is found at the diseased spots, and when the fruit is badly affected, this brown and pithy condition may be seen extending through much of the fruit. The

diseased flesh is not bitter, but is dry, tough and without flavor. When the apple is badly affected, its commercial value is almost destroyed. Various causes have been assigned for this disease, namely, want of vigor of tree, lack of moisture in the soil, want of potash and lime in the soil. By those who have given most study to the rot it is ascribed to the concentration of sap caused by the transpiration of moisture, which causes the death of the cells. There is not yet any known remedy for this disease, but it will probably not be as troublesome if there is plenty of moisture in the soil, and if the trees are encouraged to make good, healthy growth.

W. T. MACOUN

Edema

An Edema or swelling of apple twigs has been described by Atkinson from New York (Cornell Station, Bulletin 61). This on closely trimmed trees on over fertile soil.

European Apple Canker

Nectria Ditissima Tul.

This disease is reported as serious in the orchards of Europe, and is apparently becoming distributed in America. It is not of so common occurrence in New Hampshire as the black rot canker, but is more destructive where found. The fungus seems to be dependent upon wounds for entrance to the host tissue. It attacks the inner bark and the cambium, and to some extent the young wood. The mycelium is perennial in the host. As the new growth develops around the wound it is attacked and killed by the fungus; thus a series of ridges may be developed, giving a characteristic appearance to the disease.

Two kinds of summer spores are produced, the first small and unicellular, the second sickle-shaped and having three or more cells. The latter is probably largely responsible for the spread of the disease during the summer. In the spring compact clusters of red lemon-shaped perithecia may be found near the edge of the canker. These may be seen with the unaided eye. They contain numerous two-celled spores in sacs.

Treatment

All cankered limbs should be destroyed. Wounds should be thoroughly coated with paint. Spraying may serve to disinfect the smaller wounds produced by insects, hailstorms, etc.

CHARLES BROOKS

FIRE BLIGHT. See *Blight under Pear*.

FLY SPECK. See *Sooty Black*.

FROG EYE. See *Leaf Spot*.

Fruit Pit

H. S. JACKSON

This disease, otherwise locally spoken of as the "brown rot," "bitter rot," "bitter pit," "Baldwin fruit spot," etc., is in some respects one of the most serious troubles of the apple in the Northwest. It is pres-



Fig. 1. Apple Showing Typical Appearance of Fruit Pit. (New Hampshire Experiment Station.)

ent in more or less severity in all sections where apples are grown. A common disease, also, in most sections of the United States, it is serious in Germany and other sections of Europe as well, where it is generally referred to as "Stip-pin." It is also common in Canada, Mexico, Australia, New Zealand and South

Africa. The disease is too common to need a detailed description. It seems to be very variable in appearance. The most common condition is the occurrence of sunken areas one-eighth to one-half inch in diameter, which have somewhat the appearance of bruises on the surface of the apple. (See Fig. 1.) In the early stages the skin is perfectly normal in color, though often retaining the green tint longer than the surrounding tissue. In red apples the spots may be deeper in color for a time than the surrounding tissue. Later they gradually turn brown. The skin is usually unbroken in both early and late stages.

In cutting an affected apple one finds a browning of the tissue just underneath the sunken areas on the surface and similar discolorations are also frequently found scattered through the substance of the fruit. A close examination shows these discolorations are not entirely separated but are associated with the vascular system of the fruit, and connected with each other by very fine brown strands of diseased tissue. These internal spots are usually more abundant near the surface of the apple and in most varieties are found more numerous toward the blossom end. A larger amount of starch is usually found in the diseased cells than in the surrounding tissue.

Cause

Unlike most other diseases the fruit pit is presumably not caused by any organism; at least, no fungi or bacteria have been found associated with these spots. It evidently belongs to a class of so-called physiological diseases. Various explanations have been offered by investigators as to the reasons for the formation of the spots of diseased tissue. Among these explanations given by various authorities are the following: Acidity of cell sap following excessive transpiration; premature ripening; abundant moisture and high temperature; influence of stock on scion; dry weather before maturity; complete fertilizers; bursting of cells from pressure due to lack of balance between moisture supply and transpiration.

In the Northwest the disease is found on soils so diverse both as regards character and richness, and varies so greatly in abundance and severity between different seasons, that the writer is led to the conclusion, on present evidence, that the most important factors influencing its presence from season to season, are certain varying factors of climate which induce the disease by acting through their effect upon the balance existing between the moisture content of the soil, the rate of absorption by the roots and the amount of evaporation from foliage and fruit.

A trouble of the apple also very common in the Northwest usually referred to as core rot is characterized by a premature breaking down of the tissues, starting at the core. This is believed by the writer to be closely related in cause to the fruit pit and the factors influencing its presence are considered similar. It must be recognized that among the different varieties of apples the inherent differences in adaptability to certain types of environment and the natural differences in the texture of the fruit gives rise to great differences in susceptibility to such troubles.

Growers should be cautioned against mistaking the fruit pit for the "fruit spot," prevalent in the Eastern United States and particularly in New England, which has long been confused with the former. This fruit spot is caused by a fungus known as *Cylindrosporium pomi*, and can be prevented by spraying, a method which is useless in controlling the fruit pit. So far as we know, the fruit spot does not occur in Oregon.

Fruit Rot

Coniothyriose

The rotten spot is circular in uniform tissue, brownish, about the color of the common soft rot, and due to loss from evaporation, the tissue shrinks as the spot ages, leaving the surface much wrinkled. Distributed somewhat sparsely and irregularly over the spot are the fruiting cavities of the fungus. In rotten spots, produced by inoculation, these cavities frequently assume a somewhat

concentric arrangement. Proceeding from the innermost cavities toward the edge of the spot the cavities become smaller, none at all being found near the edge of the diseased tissue.

Upon sectioning through a diseased spot the flesh of the fruit is seen to be rotten, brownish and soft, not black or dry, as is the case with the volutella rot.

Microscopic examination shows the diseased tissue to be thoroughly invaded with a thin branching mycelium.

When this disease is upon twigs, the terminal portions of recent growth die, the bark shrinks and shrivels, turns black and at the line of demarkation between diseased and healthy tissue cracks. The general appearance of such a twig is much like that caused by the fire blight, but is readily distinguished by the presence of very numerous, minute, pimple-like pustules, fruiting cavities distributed over the dead part.

The significance of this fungus upon twigs is twofold: (1) As a cause of the twig blight; (2) as a source of infective material, spores, to transmit the rot to the fruit.

Treatment

Spraying coupled with careful pruning out and burning of diseased twigs and branches will doubtless serve as a means of control of this rot, both of branches and fruit.

F. L. STEVENS,
West Raleigh, N. C.

Fruit Spot

Phoma pomi Passer

This disease is of very common occurrence in New Hampshire and is found as far south as Maryland and Virginia and as far west as Michigan. It is not so destructive as the scab, but often causes otherwise perfect fruit to go as seconds. It is found on almost every variety of apple, but Baldwins and Tolman Sweets are especially susceptible. The disease appears about the middle of August. At this time it may be seen as spots of a deeper red on the colored surface of the apple and of a darker green on the lighter portion. As the season advances, the

spots become more prominent. They become slightly sunken and more highly colored. Numerous black specks appear, sometimes causing the center of the spot to have an almost uniformly black appearance. The tissue beneath the spot is rendered brown and corky to a depth of several cells. Cold storage seems to check the development of the spots, but in cellar storage they often become more



Fig. 1. Fruit Spot.
(New Hampshire Experiment Station).

sunken and spread deeper into the tissue of the apple. They become brown and are much enlarged, sometimes attaining a diameter of one-half inch.

Recent experiments* have shown that the fungus causing the fruit spot of apples is also responsible for a similar spot on quinces known as "quince blotch." The disease may spread from one host to the other.

Treatment

The fungus does not attack the apples until they are nearly grown. Consequently, sprayings made in late June or early July are usually as effective if not more so than those made earlier in the year. However, orchards that have received three and four sprayings for scab will not usually require later spraying for fruit spot. Both Bordeaux and lime-sulphur have given satisfactory results.

CHARLES BROOKS

* Brooks, Charles, and Black, Caroline A. Apple Fruit Spot and Quince Blotch. *Phytopathology* II, 63-73, 1912.

Hail Injury

There is nothing which can be done to prevent this injury, but frequently it is not noticed at the time and is later attributed to fungi, insects or other causes. The fruits may be badly deformed and scarred resembling somewhat curculio injury but the characteristic crescent-shaped scars of the latter are not present. Quite frequently hail injury is followed by fungous decays of the fruit resulting from infections of the wounds.

Hollow Trunks

It sometimes happens that a valuable shade or orchard tree becomes injured in such a way as to cause a cavity. This may have resulted from the breaking of a branch in a storm or from improper pruning. Whatever the cause the treatment is practically the same. All decayed or decaying matter should be removed from the cavity and with a sharp gouge or chisel all diseased wood cut away until sound heartwood is exposed. Then, before moisture or other injurious influences can act upon the newly exposed parts, the whole cavity should be filled with a thin mortar, made by mixing one part of Portland cement with three parts of clean, sharp sand. After the mortar has had time to become stiff, but not hard, a surface coat made of one part of sand and one part of cement should be added and the surface so faced as to exclude all moisture from the opening of the cavity. An additional safeguard would be had in treating the inside of the cavity with a copper-sulphate solution (one pound to five or six gallons of water) after the diseased wood has been removed with a gouge or chisel and before the cement mortar is poured into the cavity.

L. C. CORBETT,
Washington, D. C.

Hypocnus

Common to the mountain sections of the Southeast. This disease affects the apple, pear and quince. Trees affected have the appearance of fire blight. However, the leaves only die. They droop in

dense matted masses, and in the later stages of the disease fall away. During damp weather the fungus grows with great rapidity between the matted leaves. It spreads from joint to joint by means of ribbon-like structures. Unless outside aid is brought the branch becomes completely covered by mid-summer and the tree remains infected continuously.

Treatment

The fungus winters upon the twigs and rarely goes into the spore stage, hence, is easily controlled by the usual dormant sprays.

The Jonathan Fruit Spot Nature and Importance of the Disease

The spots, though seldom more than skin deep, detract greatly from the appearance of the apple and afford a place of entrance for decay fungi. They are dark brown in color, more or less circular in outline, at first scarcely depressed, later becoming considerably sunken, and vary from one-eighth to three-fourths of an inch in diameter. They resemble very young bitter-rot spots and are not easily distinguished from the advanced stage of the New Hampshire fruit spot (*Cylindrosporium pomi* Brooks). As many as 25 spots often occur on one apple, and a lenticel usually forms the center of each spot. Since the spots are entirely superficial, the intrinsic value of the fruit is not seriously affected, but its market value is greatly reduced.

The disease occurs only on fully matured fruit and usually develops after the crop is picked. If left on the trees long after maturing, the fruit of susceptible varieties may become affected before being picked. This was observed on the Jonathan variety in Virginia and West Virginia during the fall of 1911. According to numerous observations made by the writers, fruit picked at the proper time, or rather early, and rushed into cold storage with only two or three days' delay, and consumed within a few days after removal from storage, will not develop the disease to any serious extent. Fruit of susceptible varieties kept in

common storage or delayed in reaching cold storage usually becomes affected. The disease has been particularly annoying to fruit growers who have attempted to keep prize specimens of the Jonathan in cellar storage for exhibition purposes. The growers of Esopus (*Spitzenburg*) in Oregon and Washington have perhaps suffered most from this trouble, the spots often developing on the fruit en route to the Eastern markets.

The Jonathan is the most susceptible variety grown in the East, and its commercial standing is greatly impaired on account of this weakness. The disease is now rather commonly known among apple growers as the "Jonathan spot," and for that reason the writers have adopted the name "Jonathan fruit spot." The Esopus is almost, if not quite, as susceptible to the disease as the Jonathan, and the Yellow Newtown apparently ranks third in degree of susceptibility. It has also been observed to a very slight extent on the Grimes, Arkansas Black, and a few other varieties of less importance.

Dry weather during the summer is apparently favorable to the development of the Jonathan fruit spot. It was very bad in 1910 and 1911, both of which were dry seasons, while in 1912, a comparatively wet season, it was not common on Eastern-grown fruit. In the fall of 1911 the spotting was particularly serious on the Jonathan, specimens having been received from practically every section of the country where that variety is grown.

Summary of Conclusions

The investigations conducted by the writers seem to warrant the following conclusions:

- (1) The Jonathan fruit spot of the apple is due neither to spraying with arsenate of lead nor to a specific organism.
- (2) It is probably a physiological trouble, falling in the same category as the bitter pit or Baldwin spot.
- (3) Early picking, prompt cold storage, and immediate consumption of the

fruit after removal from storage, will largely obviate losses from the disease

W M SCOTT,
Formerly Pathologist, and
JOHN W. ROBERTS,
Assistant Pathologist,
Fruit Disease Investigations

Leaf Blight

Sphaeropsis malorum

See *Black Rot*.

Leaf Spot

Sphaeropsis malorum

See *Black Rot*.

Leaf Spot or Frog Eye

There is a common leaf spot disease of apple trees in which the dead spots show the presence of pycnidia. This trouble is really due to the black rot fungus (*Sphaeropsis malorum* Pk) but at times another fungus (*Coniothyrium pirum* Sacc), comes in afterwards. In the later season the second type develops in concentric areas to which the common name of "Frog Eye" has been given. Yet other forms of leaf spot due to spray injuries also occur, but are easily distinguishable from the two first named. It has been shown that control of the black rot fungus keeps the leaf spot in hand, but early treatments should be made.

A D SELBY.

Lichens

Not infrequently complaints are received, particularly from Atlantic coast towns, with regard to fruit trees being over-run by lichens, sometimes improperly called "mosses" by orchardists. While mosses are not uncommon on old, neglected fruit trees, lichens are much more frequent. The latter are foliaceous growths of various colors, the more common being grayish and found indiscriminately upon trunks of trees, rocks, old fence boards, etc. Quite frequently these lichens are found in large numbers upon orchard trees—apples, pears and plums—particularly so in the states farther south.

In temperate climates lichens occurring on tree trunks are not considered to be parasitic. In the tropics there is evidence that one or more kinds are prob-

ably parasitic. However, all are agreed that lichens are decidedly objectionable on fruit trees. They harbor insects and fungi, tend to keep the branches moist and more likely to decay, besides being untidy and unsightly. While they may not secure any nourishment from the trees they certainly must interfere seriously with the functions of the bark on the younger limbs.

Two or three pounds of copper sulphate to 50 gallons of water or a 5-5-50 Bordeaux sprayed on the trees before the buds swell in the spring will generally destroy the lichens. A wash such as is used for borers, consisting of one pound of potash or concentrated lye to five gallons of water, put on with a brush, is said to be effective. *None of these materials should be sprayed on the trees when in leaf on account of injuring the foliage.* Thorough spraying with 3-3-50 Bordeaux in the spring and early summer, as recommended for apple scab and other fungous diseases, would doubtless do much to hold the lichens in check, if not destroy them altogether. Hence, if the orchard is well cared for and sprayed it will not be infested with lichens.

W. J. MORSE.

LITTLE LEAF. See *Rosette*.

Mushroom Root Rot

Armillaria mellea

H. P. BARSS

In various sections of the Northwest, fruit trees are attacked by the disease known as mushroom root rot or crown rot. Starting from isolated trees in an orchard, it often spreads to surrounding trees, forming infested areas, which enlarge from year to year. Examination at the base of affected trees reveals a decayed condition on the underground part of the trunk or on large roots. Under favorable conditions clusters of mushrooms (toadstools) usually appear in the fall at the base of such trees. (See Fig. 1.) Old trees and young are equally liable to attack, and once attacked, there is little hope of saving them from ultimate destruction.

Distribution

While no careful survey has been made to determine its exact distribution, the disease is reported from the northern part of the Willamette valley and from the Hood River valley. It also appears destructively in Western Washington and California, and similar root rots are reported from the Southern and Eastern states.



Fig. 1. Mushrooms of *Armillaria Mellea* in Young Condition.

Hosts

From numerous parts of Europe and America it is reported that many forest trees, including various evergreens, the birch, beech, walnut and oak, as well as such fruit trees as the apple, plum, cherry, peach, citrus and olive, besides certain bush fruits and the grape, are attacked by very similar, if not identical, mushroom root rots. Along our Pacific coast, mushroom root rot is prevalent on many kinds of trees and shrubs. In Western Washington, Lawrence reports its presence among several native trees, both evergreen and deciduous, and mentions that in orchard and field the apple, plum, cherry, gooseberry, currant, blackberry, raspberry and loganberry were found to be badly injured or killed. In California, Horne has reported that it occurs throughout the state, attacking a great variety of hosts. He says that it appears to be capable of attacking almost any plant, in fact, that it is somewhat woody and long-lived.

Symptoms

The symptoms of the disease vary somewhat, depending upon the point at which the tree is attacked, the rapidity or slowness with which the parasitic fungus spreads, and other conditions. It is generally not until the trouble has made considerable progress that the first external evidence of the attack appears in its effect on the health of the tree. The earliest indication is usually a retarded growth, attended by early dropping of the leaves. The foliage generally presents an unnatural appearance. Often this is confined to that side of the tree corresponding with the side of the trunk first attacked. The fruit is usually poor and stunted. A tree may sometimes show such symptoms for two or three years before it finally succumbs, but death frequently occurs during the season in which the symptoms first appear, or during the following year. In rapid attacks, the leaves often become yellow early in the summer. Not infrequently the entire foliage suddenly withers and the whole tree dies in midseason. Again, death may

occur during the winter, in which case the tree fails to leaf out in the spring. Sometimes, but not always, clusters of mushrooms of a light brownish color come up in the autumn around the base of the trunk, or push through the soil above diseased roots. In some cases, this occurs before the tree is totally dead.

As soon as a tree shows the first signs of trouble, it should be examined by digging the soil away from the base, and a search should be made for decayed areas on the trunk and roots (Fig. 2), and for



Fig. 2. Trunk of Apple Tree Which Died in Midsummer. Dead bark removed to show layers of white fungus under bark.

peculiar black, rootlet-like branching strands, mostly about the thickness of the lead in a pencil, clinging to the bark. These strands, known as rhizomorphs, are characteristic of the disease, since they are a special form of the fungus which causes the rot. They can be distinguished from the roots of any small plants which may also be present in the soil, by their peculiar irregular method of branching and by the white interior substance which can be rather easily separated from the

thin black covering. The dead bark and wood is penetrated by a whitish fungous growth and has a strong mushroom odor. Sometimes rhizomorphs are found on the roots of an entirely healthy tree apparently causing no injury.

The disastrous effect of the disease results from the girdling of the main roots and the trunk, and from a destruction of the activity of the sap-wood. This brings about root starvation, a checking of the ascent of water through the wood and, as a consequence, the eventual death of the whole tree.

Cause

The cause of this disease is one of the higher fungi known as *Armillaria mellea* (or varieties) and commonly called, from its usual light, yellowish-brown color, the honey mushroom. Several forms or varieties of this fungus have been found on the Pacific coast attacking fruit trees or growing from the decaying stumps and roots of oaks and other native forest trees. The following general description of the typical *Armillaria mellea*, however, will serve sufficiently well to identify the mushroom causing the disease under consideration.

Fruiting bodies or toadstools occurring in tufts or clusters, honey-colored or light brown; irregular ring (annulus) on stem near the top; cap slightly elevated at center; margin inrolled; later flat or concave with margin upturned. Cap varying from nearly white to reddish-brown, darker toward center. Caps vary in size and stems in length. Gills under cap radiating from center shed innumerable spores which are blown about or otherwise disseminated.

Life History and Method of Spread

It is believed by many that the fungus gains its entrance, more often, if not exclusively at points where the root or the crown of the tree has been injured by cultivation, by the attacks of borers, or by the presence of a crown gall, etc. When once it has entered the tree, it sends out delicate filaments both into the bark, where, given the right conditions, it spreads rapidly, and also, by way of the

medullary rays (silver grain), into the wood, where it spreads more slowly.

The disease spreads fast from the point of attack up and down the root or trunk, apparently working most rapidly in the cambium region. Little effect on the tree is at first noticeable until the decay commences to girdle the trunk, after which the progress of the disease is rapid and the death of the tree only a question of one or two seasons.

When the decay has progressed sufficiently and the fungus is thereby richly supplied with reserve nutriment, the fruiting bodies or mushrooms may be formed. In their young condition these are edible. Abundant moisture is necessary for their development, consequently they are not met with, as a rule, till the fall rains have begun. The clusters of mushrooms usually appear at the point where the trunk enters the earth and may encircle its base. Often they rise through the soil from a diseased root or they may be attached to rhizomorphic strands connected with crown or roots.

Control Measures

The suggestions presented in the following paragraphs regarding possible modes of treatment for this disease are in no way to be considered as definite recommendations. The reason for this appears when it is said that nowhere, to the writer's knowledge, have thorough or long-continued investigations of possible orchard control methods been carried out to a successful conclusion. Furthermore, information as to the way in which the trouble may enter an orchard and the exact manner of its spread, is incomplete and unsatisfactory. Consequently, the writer is not warranted in stating that any of the methods described here are sure to give satisfactory results. It is to be hoped, however, that intelligent growers will try out various methods of treatment experimentally.

The prevalent, but not yet convincingly substantiated, idea that buried roots of forest trees in newly cleared land are a dangerous source of infection for young orchard trees, has led to the suggestion

that all roots and stumps be carefully removed from the earth in clearing, and that before planting trees, the soil be devoted to other than orchard crops for several years until the root-rotting fungus has had a chance to die out.

Evidence that much of the infection takes place where trees are injured by cultivation leads to the suggestion that cultivation close to the tree be done with greatest care to avoid injury. At the same time thorough cultivation has been advised in order to establish good aeration of the soil, since this condition is supposed by some to be unfavorable to the progress of the disease while it undoubtedly promotes the vigor of the tree.

When trees are once attacked by the fungus, death, almost without exception, is only a question of time. It seems useless, therefore, to retain in the orchard trees which will be worthless to the owner and which may become a source of infection for other trees. It has consequently been considered best to grub up at once any tree discovered to be diseased and to remove it from the orchard, taking out at the same time as much of the root system as possible. It has also been advised not to plant another tree in its place for at least three years.

If it should seem desirable to retain temporarily a tree known to be diseased, it would perhaps be safest to dig a trench about two feet deep around the tree near the tips of the roots in order to prevent the rhizomorphs, which rarely occur deeper than this, from spreading to other trees. Throw the dirt inside the ditch. Where conditions are such that the disease appears to be spreading rapidly from tree to tree, the heroic method of uprooting healthy trees in advance of the zone of infection has been suggested; but as far as we know, the disease rarely assumes such a condition in the Northwest as to warrant so drastic a method of treatment.

On account of the possibility of infection from spores produced by the mushrooms, all fruiting bodies appearing at the base of diseased or dead trees, or in other places in the orchards and fields,

should be collected while still in the button stage and destroyed by burning. Knocking them over does not prevent spore formation.

The effect upon the disease of various chemical substances worked into the soil around a tree has never been thoroughly tested out. This line of investigation may prove to be worth while, and growers are urged to make experiments upon trees known to be affected. A record of the exact treatment should be made and notes kept regarding the effect in each case.

Those who possess sufficient patience and skill, and are willing to devote the necessary time, may be able by the following method to save individual trees that are not too far gone when the disease is discovered. This method has been used in one Oregon apple orchard with considerable success. Whether it can be applied as well to other kinds of fruit trees remains to be seen. At the first sign of unhealthy foliage the tree is examined for root rot. Where this is found, the earth is removed from the base of the tree and the main roots are exposed for a foot or more. The soil is also removed from beneath the roots. The air and sunshine have access in this way to the crown and root bases. The dead portions of the bark are carefully and completely removed from trunk and roots. If a root is girdled, it is taken out entirely. After all the diseased parts of the tree are cut out, the exposed surfaces are washed with some disinfectant, such as Bordeaux mixture or corrosive sublimate. When they are dry, walnut grafting wax is applied. Then, in order to restore as quickly as possible the area of the trunk destroyed by the fungus, bridge-grafting is resorted to. A number of scions are inserted into the healthy tissue of the trunk just above the dead part, and their lower ends are connected with healthy roots. This is a delicate operation and the trees have to be braced to prevent the scions from pulling out. In an orchard recently visited by the writer, a few young bearing apple trees which were treated in this way two years ago are now apparently free from any trace of disease and as thrifty as any

of the surrounding ones. The crown and large roots of these trees had been left exposed for two seasons with no apparent ill effect, the earth being thrown back over them, however, each winter. A trial of these methods is recommended. It may be that simple root exposure would help to check the disease or that thorough cutting out and sterilization would stop its progress, but so little experimentation has been done along these lines that definite assurances of success cannot be made.

Bibliography

1910. Washington Experiment Station, Bulletin No. 3, Special Series.
 1911. Pennsylvania Experiment Station, Bulletin No. 152.
 1911. Arkansas Experiment Station, Bulletin No. 71.
 1911. Ohio Experiment Station, Bulletin No. 214.
 1912. Oregon Experiment Station, Crop Pest Report, 1911-12.
 California Com. Hort., II No. 6.
 California Fruit Growers' Report, 1910, Page 93.
 1901. Oklahoma Experiment Station, Bulletin No. 49.
 1903. Washington Experiment Station, Bulletin No. 59.

A New Disease on Apples

A new disease on apples has been reported by the Pennsylvania State College* and described as follows:

"This disease is apparently physiological, and appears most conspicuously as an affection of the twigs of the current season's growth, though it is not confined to them. The twigs lose their normal color and become dull and of a rather blistered and mottled appearance at first. At a casual glance the effect somewhat resembles that produced by an incrustation of the San Jose scale. Immediately under the epidermis of the diseased areas and extending about half way to the cambium, in the early stages, there are numerous small, brown spots or pits where the tissues are dead or dying. Later, on the surface, the epidermis usually cracks

around and over the diseased spots and they become rough, dark, and rather scab-like, and are usually slightly sunken through the drying out and death of the tissues underneath. In some cases the cracks may go deeper and involve the wood. The leaves are also affected sooner or later, probably through the girdling of the twigs below them. They turn brown, dry out and crumble, beginning at their tips and outer margins. In time, the twig, limb or whole tree may be killed.

"The disease usually becomes well developed and conspicuous by the middle or latter part of August."

No remedy is suggested but the indications point to fertilizer trouble.

New Hampshire Fruit Spot

See *Cylindrosporium Fruit Spot*.

New York Apple Tree Canker

See *Black Rot*.

Orange Rust

See *Coryneum Leaf Spot*.

PENICILLIUM. See *Blue Mould*.

Pink Rot

Cephalothecium roseum

This fungus has been found to accompany scab and seems to gain entrance to the apple at points of rupture in the skin caused by the scab. It is called "pink rot" on account of the color of the spots as the fungus matures. Its first appearance, however, is that of a thin gray film of mildew.

It develops both in and out of storage. The rot has been very destructive at times in New York. The method of control is the same as for scab, which see.

References

1902. Cornell Bulletin No. 207.
 1903. New York Bulletin No. 235.
 POME BLIGHT. See *Blight under Pear*.

Powdery Mildew

Sphaerotheca mali

H. S. JACKSON

The apple powdery mildew is a common disease in nearly all fruit sections of the Northwest.

This disease was formerly considered as most serious on nursery stock, but un-

* Pennsylvania State College Report, 1910-11.

der certain climatic conditions the disease is not uncommon on full grown trees in the orchard. It usually attacks only the tips of actively growing branches but may occur in spots on the underside of otherwise unaffected mature leaves.

This disease is caused by a fungus known technically as *Sphaerotheca mali*,



Fig. 1. Branch of Apple Attacked by Powdery Mildew.

the mycelium of which develops mainly as a covering on the surface of the growing twigs and leaves and sends feeding threads only into the external cells. The twigs present a white, mouldy appearance,

due to the growth of the threads of the fungus in considerable quantity on the surface. (See Fig. 1.) Sometimes this is so copious as to resemble felt. Spores are produced in great abundance under favorable conditions and give the affected twigs and leaves a frosty appearance. Such twigs are usually more or less thickened and shortened, and frequently distorted. The leaves present a wilted appearance and are smaller than normal.

When the disease is abundant, the normal functions of the tree are interfered with on account of the reduction in the foliage. Affected trees may fail to form blossom-buds, or the fruit may not be of good size and quality.

The fungus hibernates as mycelium on the affected twigs. This is the principal method by which it is carried over the winter. Sexual spores may also be formed in protected fruit bodies partly buried in the felted mass of mycelium.

Treatment

It has been found that this fungus, unlike most powdery mildews, is a difficult one to control. Since the fungus winters on the twigs, it might be expected that a dormant spray applied late in the spring would control the disease; but this has not been found sufficient where the disease is abundant. Investigations carried on in California by Volck indicate that a special spray, the iron sulphide, will hold the disease in check so that it will not cause serious damage, if the spray is applied as soon as the foliage buds open and is repeated at frequent and regular intervals. Where lime-sulphur can be safely used as a remedy for apple scab, it should not be necessary to use the iron sulphide.

When the disease is present only in slight amount, pruning out the diseased twigs, removing them from the orchard and burning them, will usually be found sufficient to hold the disease in check.

Bibliography

- 1909. B. M. Duggar, Fungus Diseases of Plants.
- 1910. New York Experiment Station, Bulletin No. 328.

Ripe Rot*Sclerotinia fructigina*See *Brown Rot*.ROOT BLIGHT. See *Blight under Pear***ROSETTE**

Rosette has doubtless existed for ages, and has affected many kinds of forest trees, shrubs, plants, and fruit trees. This seems a reasonable inference, from the fact that the causes have existed for ages and the results would naturally follow. It is only in recent years, however, since fruit growing for commercial purposes has become general, and since it is being studied with scientific accuracy, that rosette has been observed, and become a subject of considerable controversy.

When first observed, it was supposed to be confined to the arid regions, where the soil was largely a volcanic ash, or disintegrated basalt, and where the sun was hot enough and the air dry enough to cause a rapid evaporation from the leaf. This theory is now abandoned by those who have carefully studied the subject, and it is known that the disease exists in the humid regions of many countries as well as in the arid regions, although it is conceded to be more prevalent in arid than in humid regions. It is known too, that the disease is not confined to one species of trees, or even to fruit trees, but that ash, willow, walnut, elm, oak, and many other varieties of trees are affected by it. In the arid regions of the Pacific coast states, the disease became so prevalent, where it was generally known as "Apple Rosette," that I determined, if possible, to find the cause and the cure. I therefore began investigations, first in my own orchard, extended my observations to other orchards in our community, later to other communities, and later still to other states. Soon after beginning my investigations, I wrote fifty letters to practical orchardists, fruit inspectors, and professors in our state institutions, to get, if possible, their many viewpoints, and to see if there were any general agreement, or clearly defined consensus of opinion on the subject. The answers to these letters were very in-

structive, but showed wide differences of opinion as to causes.

My own observations were about as conflicting as the replies to my letters; for often when I had discovered what seemed to be the cause, I found rosette existing under conditions where the supposed cause was not apparent. However, I have kept up my investigations and with this disease in mind have visited many of the orchard sections in Washington, Oregon, California, Idaho, Montana, Utah, Colorado, and Texas.

The Causes Assigned

I have given here a list of the causes assigned for rosette, and in another place in this article have quoted more fully from the authors, using this as a mere catalogue selected from the replies, as follows:

- Too much water.
- Not enough water.
- Too much alkali.
- An unbalanced food ration.
- Too much barn yard manure.
- Clean cultivation.
- The puddling of the soil in irrigation.
- The bud moth, which injures the leaf buds.
- Cut worms which work on the leaves and buds.
- Some kind of bacterium or microbe.
- An enzymatic ferment, induced by injury to the bark of the roots.
- A rapid evaporation from the leaf.
- Lack of aeration of the soil.
- Hard pan, which retards root development.
- Scab soil, which lacks plant food.
- Lack of proper drainage.
- Cramping the roots in planting.
- An anemic condition of the tree similar to anemia in the human organism.

Some of the replies included more than one cause, giving evidence that the writers had observed it under conditions that were dissimilar.

Method of Investigation

In my investigation, I applied two modes of reasoning. The first was inductive, in which, by the examination and study of a large number of cases, I

tried to discover a general cause under the operations of a general law.

The second was deductive, in which, after the general cause was discovered, I tried to determine whether all the cases of rosette would be included by it.

I found that rosette actually existed under the many conditions described by the writers, in their replies to my letters. I reasoned that it must therefore be induced by many conditions, and that there must be some general cause which will include them all. I pursued the plan adopted by Herbert Spencer in the writing of his "First Principles," in presuming that "when two or more intelligent persons differ upon a subject with which they are familiar, all of them are right in what they affirm, but are wrong in what they deny."

It is like the old story of the shield, which one contended was made of copper, another that it was made of brass. It depends on the viewpoint, for on one side it was copper, on the other brass, so that it was both copper and brass.

Again, it is like a photographer of an orchard section who stands on the west side of the valley and gets for his background the hills toward the east; while another stands on the east side and gets the hills toward the west. There may be as many unlike views as there are viewpoints, and all of them correct. I contend that the same rule will apply to rosette, and that a proper analysis of the subject, and a proper synthesis of facts, will justify this claim.

The Cause of Causes

A cause is something that must have preceded, in order that an event should happen.

A primary cause is a first cause in degree, time, rank or importance.

A specific cause is one which has some property, which distinguishes it from any other.

A tributary or contributory cause is one which is not primary or specific, but contributes toward the production of certain results, as in the case of two rivers, neither of which are navigable; but when united, become navigable.

A condition is one which necessarily precedes a result, but does not produce it.

Further, when we find the conditions under which rosette exists, and inquire what are the causes of these conditions, we have gone only one step backward; for immediately we begin to inquire, What are the causes of the causes that produced these conditions? If by any means we answer that question satisfactorily, then we must inquire the cause of the causes of the causes of the conditions.

Suppose we say, as one man did, that "Rosette is caused by a rapid evaporation from the leaf in an arid climate, which prevents a sufficient manufacture of food."

We would ask then, "Why cannot the leaf manufacture a sufficiency of food?" He would probably say, "Because the trunk does not supply the raw materials to the top system."

Why does not the trunk supply the top system?

"Because the root system does not supply the trunk."

Why does not the root system supply the trunk?

"Well, perhaps the root system is defective."

Then we would inquire, What is the cause of the defective root system? The answer might include any one of a number of causes or several of them combined. For instance, it might be gophers, aphids, hard pan, clean cultivation, alkali, lack of water, too much water, etc. Inasmuch as all these conditions exist sometimes where there is no rosette, it will be seen that they are not primary, but tributary causes, contributing to a root injury without which there is no rosette. This is not only reasonable, but is true in fact, if I am not mistaken in my observations. A few of these observations I will note.

I began in my own orchard, extending my observations to other orchards, until I had dug the ground about 600 trees which were rosetted or near rosetted and examined 100 other trees that had been uprooted. I found that of the 600 trees

examined, 457, or a little more than 75 per cent, had some root injury from gall, aphid, alkali, hard pan, farm machinery or something else. This examination was necessarily superficial, because we were careful not to injure the roots, and generally the area dug was not more than one foot from the body of the tree, and not more than six inches deep. Yet with this casual examination, 75 per cent showed root injury. Of the 100 trees where the whole root was examined, every one of them showed root injury or malformation of the roots.

In Mr. Strobach's orchard, near North Yakima, Washington, I thought at first, that I had found an exception to this rule, but a more careful examination showed injury, doubtless from gophers, and I have the root on exhibition to show where the ends had been eaten off and the bark damaged. In one other orchard I thought I had found a marked exception. However, an examination of the conditions showed the following facts:

First. There was a substratum of hard pan near the surface, and this hard pan was strong in alkali.

Second. In some places it was only six inches and in others two feet from the surface to the hard pan and the average depth was only about sixteen inches.

Third. In many cases the roots of the trees were down to the hard pan and in growing could not penetrate, therefore had turned, grown laterally, and formed a kind of elbow.

Fourth. In irrigating, the water could not penetrate the hard pan, and would tend to water-log the roots of the trees.

Fifth. The orchard had been given clean cultivation to a depth of say four inches, which would cut off the tender rootlets to that depth, leaving an area below the cultivated area and above the hard pan of from two to twenty inches.

Instead of this being an exception to my rule, it became, after analysis, one of the most conspicuous proofs of it.

The Symptoms Described

I have purposely left the description by which rosette is usually judged, up to this point, because I regard that what we gen-

erally call rosette, is merely a symptom, rather than the disease itself. Three symptoms may be described as follows:

1. The leaves on one or more branches of the tree fail to develop properly and have a yellowish appearance

2. The branch on which these leaves appear, fail to elongate; and at a time of the year when it would normally have grown two or three feet in length, it has only grown two or three inches. This gives the leaves a bunched or rosetted appearance.

3. The wood of the previous year's growth has failed to enlarge and has a sickly or shriveled appearance as if it lacked vigor.

When we presume that the rosetted branch is a symptom of a disease, located on some other part of the organism, we are following well known precedents. For instance:

Jaundice in the human body is manifest by a yellowing of the skin, but physicians say it is located in the liver.

Dropsy is said to be an accumulation of serous fluid through some cavity or the cellular tissues of the body, but the real disease is in the kidneys.

A bluish skin is regarded as a symptom of heart disease, and unusual heat or dryness of the skin as a symptom of tuberculosis.

Therefore when we say that rosette is a symptom of a disease located in some other part of the organism, we follow laws by which other diseases are judged.

Another reason for this belief, and one that appeals to me with a good deal of force, is that if we take a rosetted branch and follow the avenues of its food supply down the trunk of the tree and into the root, we will find that all along the path of this circulation there are the same symptoms of disease as on the top. The bark of the tree is often yellowish, the cambium lacks vigor as is manifest at the top, and this condition is traceable to the root which is diseased or injured, in much the same manner in which a physician would trace a vein or an artery in the human body. Even the most casual observer has noted that some-



Fig. 1. Rosetted Apple Twig Showing Characteristic Bunching of Leaves Due to the Failure of the Terminal to Elongate. a, Dark spot at the center caused by the browning of the pith. Sometimes this extends for some distance down the twig. Enlarged. (Original)

times the branches on one side of the tree are healthy, while on the other side they are diseased. Invariably the diseased branches can be traced to diseased roots on the same side, unless the injury is above the ground.

On the high lands I sometimes found a lack of water. Under these conditions rosette could not have been caused by too much water, seepage, water-logging, or drowning the root hairs.

In these orchards I found that generally the rosetted trees had crown gall, nematode gall, aphid, the roots had been

State Horticulturist, called my attention. In this orchard was 75 per cent of rosetted trees. It had been neglected, field mice and gophers had so injured the roots that many of the trees had been bridge grafted to keep them from dying. In this case the dominant cause seemed to be injury from gophers and field mice. In other orchards in the same valley rosette was evidently caused by seepage water from the mountains. In other places it was evident that alkali was the cause.

In Utah

In Utah I found peculiar conditions. The fruit-growing sections of Utah are mainly in the interior parts of the state. These interior parts are surrounded by mountains and hills that drain into lakes in the interior basin. This basin was once a lake of water, several hundred feet in depth, and its outlet was toward the Snake river and from that into the Columbia. In the process of the ages, the waters cut down to a rock barrier and the lake had no outlet. Gradually the waters sank away into the earth until a hard pan was formed which held them. Now these waters are not percolating through the soil and sinking away to any considerable degree, but their only escape is by the process of evaporation. The drainage system from the mountains pours into these lakes and the water rises and falls with the floods and drouth or the melting snows in the mountains, and the degrees of heat that increase evaporation.

The soils of Utah have a strong admixture of salt, sulphur, alum, alkali and other minerals. The Great Salt lake is so strong in these substances that scarcely any form of vegetable or animal life can exist in its waters. In the early days farms were established and orchards planted so near these waters that the rise and fall of the water table destroyed the roots. Then too, the water table is slowly rising, for the evaporation from the lakes is not equal to the waters drained into them and the waters are slowly encroaching upon farms that were once fruitful. Much the larger part of



Fig. 2. Terminal Bud Showing Origin of Leaves. f, leaf rudiment; g, rudiment of axillary bud (x 10). If, as in the case of rosette, this bud failed to elongate the leaves would appear in a bunch or "rosette" instead of being distributed along the branch at intervals of several inches. From Strasburger's *Lehrbuch der Botanik*; *Ency. Brit.*

injured by gophers, farm machinery and sometimes all of these combined. Sometimes the roots were struggling to get their food from scab land or hard pan, and were stunted or malformed. One-year-old nursery stock is sometimes injured by gophers or woolly aphid, and rosette appears. Again, the graft sometimes fails properly to unite, gall forms at the union and rosette appears.

In Montana

In Montana in the Bitter Root valley is an orchard to which M. L. Dean,

rosette in Utah is from the effects of these saline waters. Sometimes it is found on the bench lands where there is seepage from the mountains. I found a few rosetted trees with galled roots, gopher and aphid injuries where there seemed to be no rise and fall of the water table and no seepage from the mountains, but by far the larger part of damage was evidently caused from water.

Nevada

I did not visit Nevada, but from information that is undoubtedly reliable, the conditions are similar to those of Utah. There the agricultural and horticultural regions are surrounded by mountains that drain into lake basins like Pyramid Lake, Carson Lake and Walker Lake, that have no outlets and the water rises and falls with similar results to those of Utah.

Grand Junction, Colorado

At Grand Junction rosette is common and the worst rosetted trees are on the low lands where the water is heavily charged with alkali. Their problem of drainage will become serious with the irrigation of their higher lands.

Crossing the Great Divide at Tennessee Pass, I came into the Arkansas valley. In this valley the great orchard sections are near Canyon City. Here we found the same causes and the same effects as on the west side and were reminded again of the "Unity and Universality of Law," and that everywhere similar causes produce similar effects.

I have found rosette on high lands and low lands; on soggy soil and dry soil; on shallow soil and deep soil; on gravelly soil and the finer volcanic ash; at Bremerton, on Puget Sound, and in Texas, near the Gulf; in Washington, Oregon, California, Montana, Utah, Colorado, Kansas, and Oklahoma. I have authority for saying that it is found in West Virginia, the Carolinas, and in Europe. Of course in the humid regions it grows under different conditions and is not so prevalent. Some of the conditions that produce it are not present in the soils of the humid regions, but some of them are, and the reason it has not been largely observed

is because we have not trained ourselves to observe it. In fact, it existed in the orchards of the Pacific coast states years ago, but it has only been noted within the last two or three years.

Rosette Anywhere

Anywhere rosette might exist under the following conditions, viz.:

1. Where there is good soil and plenty of plant food, but where the organs for the assimilation of food are injured.
2. Where there is too much water and the oxygen is excluded from the roots.
3. Where there is not enough water, and plant food is not available.
4. Where there is too much alkali, and the root hairs are destroyed.
5. Where there is hard pan and as a consequence the roots are malformed, so that there is not a proper circulation, nor sufficient plant food available.
6. Where the roots are injured by clean cultivation.
7. Where gophers or other rodents injure the roots.
8. Where aphids, eel worms or other insects injure the roots.
9. Where the trees are set in a scab soil that contains but little plant food.
10. Where land is puddled by irrigation, excluding the air and smothering the root hairs.
11. Where the water contains mineral elements that destroy the root hairs.

There are other conditions under which it might exist, but to sum it all up, the roots are the feeding organs and in proportion as these organs are injured, in that proportion the supply of food is cut off, and injury must result that would become manifest in the top.

I conclude, therefore, that the claims of those who seem to be in conflict as to the causes, are all of them right; for I think I have verified most of them. That is, they are right in what they affirm, and are in danger of being wrong in what they deny.

The Cure of Rosette

The cure of rosette is not the same in every case.

While it is true that we must strive to

remove the cause, and root injury is a cause without which I do not believe rosette will exist, yet root injuries are not all from the same causes, and the varied contributory causes are conditions which precede the results and we must strive to correct them.

For instance, if there is a condition where the root hairs are perishing for lack of water, the remedy is more water.

If the root hairs are being injured by too much water, the remedy is less water.

If there is underground seepage, the remedy is drainage.

If the roots are cramped by a hard soil, the remedy is dynamite or alfalfa.

If field mice or gophers injure them, kill the mice and gophers.

If the soil lacks humus, manure it.

If it has too much alkali, wash it out, or drain the land, if you can.

If root injuries are caused by aphids, kill the aphids.

In every case of a rosetted orchard I have observed, where alfalfa or clover has been sown, the conditions have been improved. This would not correct the injury where the alkali or other salts were strong enough to kill the alfalfa.

In case the cause is crown gall, or some other form of gall, I have no knowledge of a remedy which I could recommend, but think that alfalfa or dynamite might open up the soil and improve the conditions. I have strong faith that alfalfa will improve the orchard conditions in the arid regions.

Opinions from Various Sources

In 1897 Cavara caused on the roots of the vine, what he called "tuberculosis or gall," by means of material which he had shipped from Venice and from which he made pure cultures and performed successful inoculations. The following citations are from his article on the subject:

"The plant attacked presents the following characteristics:

"A rachitic development of the leaves. Color of the leaf greenish yellow." The word "rachitic" means a bunching or clustering of the leaves as in case of a raceme or spike.

In this case then, we have a bunching

of the leaves, a yellowing of the leaves; this bunching and yellowing caused by gall.

In U S Bulletin No. 213, Bureau Plant Industry, it is stated that an analysis of sap from crown gall showed that it contained an amount of acetic acid. See p. 174, Bull. 213

Professor J. W. Toumey, formerly of the Arizona Station, said: "The warty growth in crown gall is due to a vegetable organism or slime mould fungus. When these galls grow until they girdle the trunk, they interfere with the movement of the sap. Affected trees show signs of starvation, yellowish foliage and enfeebled growth. Young trees often die of the disease."

Here Professor Toumey describes something very similar to rosette, and affirms that these conditions are due to crown gall.

The U. S. Bulletins with those of Canada give the information that 485 species of trees, shrubs and plants have been observed to have galls, caused by insects, rodents, birds, or other injuries, and give a number of cuts showing the effects upon the leaves or branches, and the tendency is always toward a rosetted condition.

The article on "Galls" in the new Encyclopedia Britannica shows that gall is found in Europe on many of the forest trees. I have found the same things in the forests of this country, and on some of the forest trees in the orchards of this country, and have often been able to discover gall on the roots because of the rosetted condition of the top first attracting my attention.

In North Carolina Bulletin No. 206 Professor Smith says: "The presence of woolly aphids on the roots may often be detected from the outward appearance of the trees. If badly infested, they usually present a sickly appearance, indicated by scant foliage of a yellowish color, and a dwarfed growth. After the aphids have been present for two or three years, the roots become so badly weakened that the entire tree may become loosened or pushed over. Similar to all plant lice, the

aphids subsist on the plant juices, feeding by means of feeding or sucking beaks. Wherever they feed, galls of greater or lesser size are produced."

In this bulletin then we have it taught that aphis produces gall and that gall produces on the top a condition similar to what we call rosette.

Professor Ralph E. Smith, of the California University, says: "Rosette may be classed with 'Die Back,' 'Little Leaf,' and 'Club Tip.'" "The symptoms are a stunted, weak growth of the shoots." "Such effects are produced most commonly perhaps, by a long continued dry season in the fall, causing the trees to become specially dormant, followed by warm spring-like weather during the winter, soon after the first rains." "But apple rosette may be caused by unfavorable soil conditions, or unfavorable climatic conditions which check the growth of the terminal buds."

California Bulletin No. 218 says: The disease called in California "Club Tip" seems to us the same as that which in Washington and Oregon is generally known as "Apple Rosette."

Professor Wickson, of the University of California, says: "Lack of proper moisture may cause the root hairs to perish, as well as too much moisture, alkali or other causes. These conditions are manifest in 'Die Back,' 'Yellow Leaf,' and other forms of ailment on the tips of the branches."

Professor A. D. Selby, of the Ohio Agricultural College, says: "Peach Yellows and Peach Rosette are similar diseases, if not identical in origin. They are caused by an enzymatic ferment which causes a physical breakdown of sap cells and chlorosis, or yellowing of the leaves." See Ohio Bulletin 214.

Henry Marshall Ward, Professor of Botany, Cambridge, England, says: "All important results of bacteria are due to poisonous bodies or toxins formed by them. Bacterial infection is in the nature of an intoxication. They, however, multiply living organisms in the tissues which fact regulates the supply of toxins.

"The effects produced are as follows:

"1. Tissue changes in the vicinity of the bacteria.

"2. Tissue changes produced at a distance by the absorption of their toxins.

"3. Degeneration and death of the cells"

M. L. Dean, State Horticulturist, of Montana, says: "Rosette is an anemic condition of the tree similar in nature to anemia in the human organism. When there is a lack of vital force on account of lack of food, or lack of assimilation of food, this disease may appear."

Professor W. S. Thornber, formerly of Washington State College, said: "We have learned that by cutting off the surface roots of young growing trees, as is done by the cultivator on soil underlaid with hard pan, we produce a yellow, starved growth, known as winter desiccation or fruit tree rosette."

T. O. Morrison, Washington State Horticulturist said: "I do not believe rosette is a disease, because I have been unable to grow a culture of it in potato agar. It is a condition, not a disease. I believe that a very unbalanced condition between the roots and the top will produce it. In many cases, I believe, it has been caused from girdling the roots by gophers, or root pruning to produce fruitfulness, clean cultivation, or lack of available nitrogen."

Clarence Starcher, former fruit inspector, said: "In my opinion, the cause is lack of nutrition, or an unbalanced soil condition. This may result from lack of proper drainage, too heavy manuring of shallow soils, or a combination of too heavy manuring and lack of drainage."

Dr. P. W. Cornue, fruit grower, said: "I would call it a disease of malnutrition. It may be lack of an available balance ration as in drought, where the food is not in solution; or mechanical injuries to roots or limbs, including winter injury; or constriction as from galls; or an unbalanced ration as an excess of some elements and a deficiency of others, as too much alkali, too much horse or hen manure."

Dr. F. F. Gray said: "Apple rosette is caused by lack of air, which causes nodules to form on the roots and prevents

the circulation of sap and the food substances. This lack of circulation and lack of air, is caused by the packing or running together of the soil particles in irrigation, forming a tough, waxy substance through which water does not penetrate, nor the air circulate."

Some of the letters and bulletins from which these extracts were taken are nearly two years old, and may not fully represent the views of the writers and authors at the present time, but I have seen nothing from their pens to the contrary, and believing that they express truth, I have quoted from them in support of my own views.

"Rosette occurs in the pecan and the following note as to its cause and distribution from M. B. Waite, of the Department of Agriculture, is appended.

"The pecan rosette occurs in humid regions. I have seen it most abundantly in South Carolina, Florida and Alabama. I am under the impression also that it occurs in Texas, but have not any definite reports by which I can give you its distribution in that state positively. The points in which I have observed it in South Carolina, Florida, Georgia and Alabama are not only in the humid Eastern states, but in distinctly moist sections near the Atlantic seaboard and the Gulf coast. The pecan grows with great luxuriance in the bottom lands along the Mississippi and its tributaries in Louisiana, but I do not recall having seen the rosette on these bottom land trees. I have not, however, personally hunted for the disease in this section.

"Doubtless you know that the pecan rosette is a little known disease. It is under investigation by the Department and is supposed to be a physiological trouble induced by soil conditions. We are not prepared, however, to say just what these conditions are.

"Now, as to the apple rosette, it does occur rarely in the Eastern states. It has occurred at Winchester, Va., during the years 1911 and 1912, on a few trees of York Imperial in a young apple orchard five or six years old and just beginning to bear some fruit. It was also found in

1911 in Loudoun county, Va, east of the Blue Ridge and some 30 miles distant from Winchester. It is a notable fact, however, that this rosette should appear after two or three very dry seasons. In the district named, the latter part of the season of 1909 and the seasons of 1910 and 1911 were notably dry, particularly the summers. Springs and wells, as well as streams, were lower than they had been for many years. Fairly good crops were produced, except the hay crop of 1911, due to drought in June, but there is no doubt about the general deficiency of subsoil moisture during this period.

"It should be stated that apple rosette is so rare in the East as to be only of scientific interest. It is not abundant enough to be of any serious economic importance east of Nebraska and Kansas. From those states westward it is one of the most important orchard diseases. The disease called Chlorosis, which we have considered to be somewhat related to rosette and which intergrades with it in the West, behaves in the same way. This physiological trouble is an important disease from the Missouri river westward, but is rather scarce all over the humid states. It occurs, however, much more frequently than the rosette, and I have observed it in several states, notably New York, Pennsylvania, Maryland, West Virginia and Virginia."

GRANVILLE LOWTHER

Rust

Gymnosporangium spp.

Apple rust is a widely distributed disease, and in some sections is quite injurious. It is of common occurrence in Eastern states and, while not one of the most serious apple troubles, it often does considerable damage. It sometimes attacks the fruit, but its effects are usually confined to the foliage. Here it causes yellowish spots which usually become somewhat elevated in the center and in which are produced numerous spores. The spots usually appear on the leaves in June. The spores from these spots are borne by the wind and attack the twigs of Junipers, causing morbid growths or swellings. One of the most characteristic



Fig. 1. Rust on Apple Foliage and Cedar Apple. (New Hampshire Experiment Station.)

effects produced is the so-called "cedar apples." The fungus passes the winter on the Juniper and in the spring produces gelatinous outgrowths that contain numerous spores. These spores, when borne back to the apple foliage, produce the rust again, and thus the fungus passes from one host back to the other.

Treatment

Spraying has not usually been very effective in controlling the disease. Since the Junipers harbor the fungus through the winter the method of control is, obviously, to destroy them.

CHARLES BROOKS

The Pacific Coast Cedar Rust of the Apple, Pear, Quince and Related Pome Fruits

Gymnosporangium blasdaleanum

For several years the writer has been studying a rust on several cultivated and native species of the pome family. In 1908 the fruiting stage of this rust was found on the serviceberry, and on the thorn apple or haw. Later the same species was found on the apple, pear, quince

and the native pome fruits as noted below.

The final stage of this rust is found on the incense cedar.

During the past six years the writer has paid particular attention to this rust, for the reason that it is of considerable economic importance. While it occurs rather sparingly on all varieties of apples so far observed, it has been found to attack certain varieties of pears very seriously. The quince is also subject to considerable injury by this rust.

In 1910 and again in 1912 serious infections of this rust were noted in some orchards in the Rogue River valley. In 1912 the writer's attention was called to a very serious infection in a small block of pears of the Winter Nelis variety which practically destroyed 95 per cent of the crop. The fruit was badly deformed and fully 50 per cent of the leaves were found infected. The attention of the writer was called to this orchard by P. E. Zepp, who brought specimens to the laboratory and who, under date of June 20, 1912, wrote the following in answer to an inquiry made by the writer:

"A block of 150 pear trees (mostly Winter Nelis) on the west side of the orchard was so badly diseased that the entire crop was lost. The fruits were covered with yellow spots and were all twisted out of shape. Later, these fruits dropped off. The foliage was also badly injured and it was hard to find a leaf that was not attacked. There were other varieties in the orchard that also had rust on them. Even Kieffer pears were attacked, but the Winter Nelis was most hurt."

All varieties of pears are not equally susceptible, but both European and Oriental varieties were found affected. Oriental hybrids, such as the Kieffer, showed infection in a more or less serious degree. The incense cedar, which bears the resting stage, is very common in Southern Oregon, being found on the floor of the Rogue River valley and on the dry hillsides. The rust was not noted as affecting the cultivated pome fruits until the orchards were pushed into the foothills in the

vicinity of stands of infected cedars and native pome fruits.

The examination of the orchard mentioned by Mr. Zepp in his letter as quoted revealed a very interesting situation. Not over 100 feet from the nearest pear tree stand half a dozen incense cedar trees of various ages, from those but a few years old to those probably 50 years old or more. A careful examination of these trees showed that practically the entire foliage was covered with the telial stage. The readiness with which the nearby cultivated pome fruits, as well as the cedars, were infected might easily be understood, since the heavy wind currents, moving up and down the small canyon in which the trees are growing, easily carried the spores.

During the course of the writer's studies inoculation experiments were taken up and it was shown that practically all pome fruits could be infected by this rust.

Hosts

The hosts upon which the fruiting stage of this rust have been produced by inoculation from the incense cedar, are as follows:

Apple, flowering crab, pear, mountain ash, native crab apple, quince, Japan quince, serviceberry, thorn apple or haw.

P. J. O'GARA

Scab

Venturia pomi

H. S. JACKSON

Apple scab is the most serious and most generally distributed fungus disease of the apple known, and in the Northwest during favorable seasons, west of the Cascade mountains, is particularly severe.

Symptoms

Apple scab attacks both foliage and fruit. On the foliage the spots are at first more or less circular in outline, olive green or brown in color, becoming darker and more irregular in shape as they become mature. The leaves are frequently more or less curled or wrinkled. When the spots are abundant, the leaves fall prematurely and considerable defoliation may thus take place when infestation is

abundant. This may result in a failure of the fruit buds to develop normally and so affect the amount of the crop the following year.

On the fruit the fungus produces more or less circular spots of a greenish-black color. The vegetative stage of the fungus causing the disease develops under the cuticle of the apple fruit, finally rupturing it by the elongation of the threads which bear the spores. The ruptured cuticle may frequently be seen clinging as whitish membranous shreds about the edge of recently developed spots. As the spots become older, all trace of the fungus may become obliterated and the only evidence of the former spot is seen in a large or small, rough, russeted spot. Frequently the fruit is distorted when mature as the result of early scab infections. Where scab spots are abundant the fruit may become cracked. Scab in any degree of severity on the fruit renders it unsightly and unmarketable as fancy fruit.

In the spring of 1912 at Corvallis, apple scab was observed to develop abundantly while the trees were in blossom on the sepals, petals and ovaries, as shown in Fig. 1.

Cause

As noted above, apple scab is caused by a parasitic fungus. The technical name of this fungus is *Venturia pomi*. Two distinct phases are known, the conidial or summer spore stage and the sexual or ascus spore stage. The summer spore stage develops on both foliage and fruit



Fig. 1. Apple Scab on Blossoms. Note spots on petals, sepals and ovaries.

in spring and summer and causes the spots described above. The spores of the fungus are produced in the spots on leaves or fruit in great abundance, and are disseminated by the wind, spreading the disease to other leaves and fruit. One finds the scab spots first appearing in the spring on the under side of leaves on the lower branches. Spores produced in these spots are disseminated to other leaves and to the developing fruits. Several generations may thus occur during a single season.

The mycellum of the fungus present on the leaves which fall to the ground in the autumn does not die, but develops in these leaves during the winter as a saprophyte, and in the spring produces spores quite different both in manner of formation and in the shape and size from those borne in the spots on living leaves and fruit. The spores found in the spots on leaves and fruit are one-celled, rarely two-celled, and are borne on the ends of short threads, while the spores developed on the dead leaves in spring are always distinctly two-celled and are borne in little cylindrical sacs called asci. A considerable number of these sacs are borne in a hollow, more or less pear-shaped receptacle buried in the tissues of the leaf. These receptacles containing the asci are known as perithecia, and when mature project as little black elevations from the surface of the leaf. These are barely visible to the naked eye. At maturity an opening appears in the projecting elevations. The asci elongate and protrude through this opening and forcibly eject the spores, which, wafted by currents of air, may be carried to the young leaves of the apple, where they germinate and produce the first scab spots. The sexual spores are disseminated about the time the blossoms open. So far as is known, all primary infection of the leaves and fruit in the spring takes place as a consequence of disseminations of the sexual spores. Subsequent infections result from the dissemination of the conidial or summer spores.

The development of the scab fungus is found to be very much influenced by

weather conditions. Moisture on the surface of leaves and fruit is essential to the germination of the spores and the consequent infection of the plant. On this account scab is found to spread most rapidly in the spring, early summer and late fall. The disease spreads little, if any, during the summer in dry seasons. In seasons of



Fig. 2. Scab on Apple Leaf. New Hampshire Experiment Station.

frequent summer rains, as in 1912, scab may spread all summer, if the trees are not properly protected by spraying.

Apple scab is not uncommonly found developing in storage. If fruit infested with scab is stored the fungus may continue to develop around the edges of the old spots. New spots due to infection in storage may also occur. It is not uncommon to find small black spots of apple scab developed on apples in storage, particularly in the hollow about the stem. This may occur on fruit that was perfect when stored.

Treatment

As with all fungi of this nature, treatment must be preventive rather than curative. The method of treatment is depend-



APPLE SCAB

Apple scab. A branch of an apple with several spots of scab on the bark. A section of the branch is shown with many spots of scab on the bark. A leaf is shown with several spots of scab on the surface. A cross-section of an apple is shown with several spots of scab on the surface.

ent on the life history of the fungus causing the disease. Since the fungus winters over on the fallen leaves, it would be advisable to destroy all such leaves before blossoming time. The usual recommendation is to plow the orchards early in the spring before the trees blossom, in order to bury the leaves in which the ascogenous spore stage is developed. Theoretically, the best way to destroy the leaves would be to rake and burn them before plowing, but pathologists have hesitated to make this recommendation on the grounds of impracticability.

In any case, the trees should be given at least three sprayings during the spring. The first application should be made as the blossom buds begin to separate in the cluster and show color, the second should be applied just after the petals fall, followed by a third application 10 days or two weeks later. Should the third application be followed by prolonged rains, a fourth may be found profitable.

Formerly Bordeaux mixture was used almost entirely as a preventive of scab, but in certain sections of this country, notably under the climatic conditions prevalent in the Northwest, the injury from russeting has been so severe as to make its use prohibitive. On this account lime-sulphur has largely supplanted Bordeaux as a remedy for this disease.

In the Willamette valley repeated experiments conducted under the direction of Prof. A. B. Cordley have shown that lime-sulphur (stock solution 30 degrees Baume) diluted one to 30 with water, applied in three sprayings as recommended above, has given excellent results in the control of apple scab. This method is now used by most growers in the Willamette valley.

The fall applications of Bordeaux mixture recommended for the control of the apple tree anthracnose, will doubtless have a tendency to reduce the spread of the apple scab in the fall and may prove to have a beneficial effect in retarding the development of the ascogenous stage in the leaves which fall to the ground coated with the spray.

Bibliography

- 1891 Ohio Experiment Station, Bulletin Vol IV, No 9
 1897 Ohio Experiment Station, Bulletin No 79
 1899 Ohio Experiment Station, Bulletin No. 111.
 1909 Duggar, Fungus Diseases of Plants.
 1910 Ohio Experiment Station, Bulletin No 214
 1912 Montana Experiment Station, Circular No 17

Scurf

Phyllosticta prunicola Sacc.

The branch scurf fungus is believed to occur in Ohio. This causes roughening of the bark, but no statements can now be made as to its possible seriousness.

A. D. SELBY

SHOT-HOLE FUNGUS. See *Leaf Spot*

Silver Leaf

Stereum purpureum, Pers.

Attacks a variety of plants in Europe and reported in 1910 from Nova Scotia. Trees affected may be cherry, plum, almond, apple or pear. The leaves have a peculiar silvery appearance or milky-white gloss on the upper surface which appears brittle when bent. Branches attacked die after one or two years. The whole tree eventually succumbs.

Remedy

Cut off affected branches as fast as they appear and burn. Paint all wounds with white lead.

SOFT ROT (*Sclerotinia fructigina*). See *Brown Rot*

Sooty Blotch and Fly Speck

Leptotherium Pomi (Mont. & Fr.) Sacc

The sooty blotch and the fly speck of the apple were formerly thought to be caused by two different fungi, but a recent writer* claims that one fungus is responsible for the two diseases. The names given to these two effects characterize their appearance. The former produces blotches one-eighth to one-half inch in diameter on the fruit (Fig. 1) and the

* B. F. Floyd in Duggar's Fungus Diseases of Plants



Fig. 1. Sooty Blotch of Apple.

latter numerous minute specks. They give the apple a sooty appearance that depreciates the market value. The fungus growth is entirely on the surface of the fruit, and hence the disease is especially dependent upon the moist weather for development.

Treatment

The disease is readily controlled by spraying. Thorough pruning is important, and if light and air have free access to the fruit the disease usually gives little trouble.

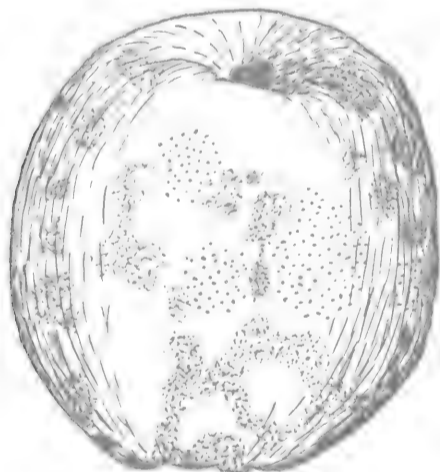

Fig. 2. Sooty Blotch and Fly Speck Fungus.

Sooty Mould *Capnodium* sp.

Black sooty fungus sometimes found growing upon branches and twigs. Frequently caused by the deposits of "honey dew" from aphids, which is a favorable medium for the growth of the fungus. Not serious.

Spray Injury

Injury from Bordeaux mixture is of quite common occurrence. On the leaves

it appears first as purplish brown spots of various shapes and sizes. They are usually smaller, irregular in shape and thickly distributed on the affected foliage. Soon after the appearance of these spots the leaves may begin to turn yellow. Leaves so affected soon fall, and in serious cases the trees may be almost entirely defoliated. Such extreme cases, however, have been very rare.

On the fruit the injury appears first as small, black or brown specks scattered thickly over the apple. Later in the season the skin may become corky and russeted. In serious cases the apple may be much roughened and deformed, and large, deeply-sunken scars develop. The slightly affected fruit may almost entirely outgrow its injuries by picking time, but when the injury is very great the fruit may drop before maturity, and in any case is of little commercial value.

The most serious injuries have been obtained from the early sprayings. This may be largely due to the fact that showers are common at that time of year. It is a well-known fact that when an application of Bordeaux is followed by rain within the next few days it is likely to produce injury. Records from a large number of cases of Bordeaux injury would indicate that damage seldom, if ever, occurs in properly sprayed orchards except under the above mentioned conditions.

The injury done by Bordeaux has not been great enough to offset the good accomplished, and various commercial growers have annually obtained large profits from its use, yet the condition has been serious enough to make strong demands for a solution of the difficulties. The matter has been taken up at various experiment stations, including those of New York,¹ Illinois² and New Hampshire, but a complete solution of the problem has not been found.

Much trouble may arise from the use of improper mixtures and from unsatis-

¹ Hedrick, N. P. Bordeaux Injury. N. Y. Agricultural Experiment Station Bulletin 287. 1907.

² Crandall, C. S. Bordeaux Mixture. Illinois Agricultural Experiment Station Bulletin 135. 1909.

factory methods of application. Only good material should be used, and the following of the directions for making the solution is important. The foliage must be thoroughly covered, but dripping from the leaves indicates an excessive or careless application. The nozzles should be of a kind adapted to give a very fine spray. Nozzles that give good results with insecticides may be entirely unsuited for Bordeaux. The Mistry and Friend's nozzles have given good results. The liquid should be applied to the tree as a fine mist and never allowed to sprinkle or drip from the nozzles. Mistakes are often made by trying to spray with insuffi-



Fig. 1. Apple Russeted by Bordeaux
—Charles Brooks

cient power. A pressure of 70 pounds is essential, and one of 100 pounds or over is very desirable.*

In looking for a solution of the problem various kinds and strengths of Bordeaux have been tested. While weaker solutions may produce less injury, they do not obviate the trouble. The use of an excess of lime has had little or no effect upon the amount of injury. The 3-3-50 formula seems to produce as little injury as any, and is most satisfactory for the majority of apple diseases. The patent Bordeauxs which are on the

* (In the Northwest 200 lbs. pressure is a common practice.—Ed.)

market have not been shown to be any less liable to produce injury than the home-made mixtures, and many of them have proven quite inefficient in controlling diseases.

During recent years lime-sulphur solutions have been rapidly gaining favor as fungicides. They seem to be almost as effective as Bordeaux in controlling diseases and to be less likely to cause injury. In the summer of 1909 commercial, home-made and self-boiled lime-sulphur were used alongside patent and home-made Bordeaux. None of the sulphur mixtures caused injury, while none of the Bordeauxs failed to do so. Recent experiments in other states have shown that when sprayings are followed by excessively hot dry weather the lime-sulphur is more likely to cause injury than Bordeaux. Probably the strongest argument against the use of lime-sulphur in New England is that it is very soluble in water and in rainy seasons more frequent applications are likely to be required to secure the same efficiency as obtained with Bordeaux.

CHARLES BROOKS

New Hampshire Experiment Station Bulletin 157.

Stag Horn

Very frequently apple trees are seen with the topmost branches dead and remaining as dry sticks like antlers projecting above the foliage. This condition may be due to various unfavorable conditions, but in New England it is chiefly encountered with old trees which have long remained unsprayed, unpruned, uncultivated and unfertilized. This allows opportunity for wood destroying fungi to gain an entrance. Once started their growth will eventually destroy the whole tree. Severe heading back and clearing out of the dead and fungus infested wood followed by cultivation and fertilization should be resorted to. In some instances it may be necessary to top-graft to renew the head of the tree. The full results of such treatment do not show the first year. Great care should be taken not to leave wounds through which the spores of fungi can gain an entrance to cause future decay.

W. J. MORSE

Stigmonose

This trouble, occurring upon apples and pears, is caused by insect punctures. The surface of the fruit shows sharp depressions. Cut through the point of one of these pits, the tissue of the flesh shows brown and dry following the track of the puncture.

Not serious in the Northwest.

Storage Rots

These rots of the apple are extremely various, since apples infected before storage are liable to develop during storage the forms of rot due to that infection. Even bitter rot may not be overlooked in this way and much more commonly still, black rot and the rots which develop from the gradual invasion of molds. It is found, furthermore, that bruises upon the apple or any tendency to sun scald phenomena give dead tissues in which various saprophytic organisms that normally hasten decay will do their work with rapidity. It is understood, of course, that the temperatures of storage will regulate or control more or less perfectly the rate of this development. Storage scalding of apples is much worse in some varieties, notably in York Imperial, than in the normal toughened skin types. At present, one can only suggest the rejection of those sorts susceptible to scald for cold storage keeping.

Sun Scald, Collar Rot

There is frequent complaint of the dying of the trunk of both younger and older apple trees wherein there appears to be associated the exposure to sun and the death of the bark of the trunk upon younger orchard trees. The freezing injury has been carefully worked out in recent years with several varieties of apples, notably the Grimes and King. This trouble is so serious as to reduce the growth of these sorts; while Murrill has suggested a connection between a fleshy fungus and this dying of the trunks of the King, the connection has not been proved. The injuries which occur on the south and southwest exposures of the trunk have probably a direct connection with the danger from freezing injuries.

Some apparent sun scald is more probably due to the bacterium of pear blight as has been recently proved by cultures from young trees by Waite. With Grimes and other varieties susceptible to collar rot caused by the bacterium of pear blight the only true relief is found by top working on some vigorous sort, such as Baldwin, Gano, and like varieties. In the case of true sun scald the effect of freezing is to form an ice layer and thus separate the bark or, in the case of many water-gorged cells, to kill the sap layer. For further discussion in this line see winter injury.

See *Collar Rot*.

Sun Scald on Fruit

Accompanied by hardening and cracking of skin and tissues of the apple. Sometimes following spraying during hot weather, but by no means always true.

Syncarpy

Double or triple fruits caused by the fusion of two or more separate lateral blossom buds. The variation occurs but rarely and is not pathological.

Twig Blight

This disease of the apple, caused by the bacterium of pear blight (*Bacillus amylovorus* Burr.), is often very prevalent. The microbe enters through the blossoms, being propagated in the nectar after infection by insect visitation. It destroys the blossoms as well as small twigs of the tree. Beyond the injuries just noted this microbe may gain entrance through the bark.

See *Sun Scald*.

Remedy

The prevention will lie in the destruction of all the blighted parts on apple, crabapple, pear and quince trees in the vicinity. For fuller discussion see pear blight. In substance, this treatment consists in cutting out all blighted portions in fall and early winter and burning them to kill the resting forms of the microbe.

Variegated Foliage

Occurs rarely. The leaves of a branch or section of a tree and occasionally the

whole tree will have leaves streaked with yellow.

Not pathological.

Volutella Rot
Volutellose

A black rot of apples, closely imitating in appearance that caused by *Sphaeropsis*, but differing from sphaeropsosis in several details, is reported from South Carolina¹

In general appearance the disease consists of a rotten black spot, the spot increasing in size until it eventually encompasses the whole fruit. The central and older portions of the decayed region are of an intense coal black color. The younger region of the spot, its outer border, a zone about five-eighths of an inch wide, is brownish.

Spray as for scab and black rot.

THE WATER CORE OF APPLE

P. J. O'GARA

Water core of apple is a trouble which is not restricted to any one district where apples are grown, but is found to occur more or less generally over the country, particularly in the arid and semi-arid districts. Reports of this trouble have also come from apple-growing districts of Europe, Asia and Africa. Although the trouble has been known for some time, data of very little importance is to be found in American plant pathological and physiological literature. It seems that very little serious work has been done in the matter of determining the true cause of the disease. Some European writers have held that the disease is caused by bacteria, although others have shown that the trouble is not due to any parasitic agency.

The writer has done considerable work on this disease during the past few years, and in no case has it been possible to identify any organism as the causative agent. All the methods known to modern bacteriology especially those used in the study of ultra-microscopic organisms, have failed to show the presence of any organism. Numerous attempts have been

made to inoculate healthy fruits by injecting the juice from water-cored spots of diseased apples, but in no case did the inoculated fruits develop any symptoms of water core.(1) The writer has noted the presence of various organisms, especially *Alternaria sp.*, but in no case could it be shown that any organism caused the disease.

The characteristic appearance of water-cored apples is so well known that a minute description is hardly necessary. The affected apples have hard watery areas extending outward from the outer edges of the seed cavities. In the beginning stages, the first appearance of water core is in connection with the vascular system. Each bundle will show a water-soaked area surrounding it, and, as a rule, this area makes its appearance a short distance from the stem. As the vascular system is variously branched upward, water-soaked areas may appear at almost any place in the fruit. In the later stages the seed cavity usually contains liquid, and the hard inner membrane of the carpels is cracked and covered with hair-like growths which finally assume a brownish appearance. The fruit has a somewhat sweetish, fermented flavor, and the watery parts contain more sugar and less acid than the normal or unaffected parts. It is during the later stages of the disease, especially where cracks appear in the calyx or blossom end, that we find fungi and bacteria present. *Alternaria sp.* is a common intruder, and produces a serious core rot. This latter trouble, namely, *Alternaria* infection, may be prevented by the proper and timely application of Bordeaux mixture.

It must be understood that no single condition may produce water core; as a rule, it is a combination of perhaps two or more factors. In some cases avoidance of the trouble may be possible; however, for the most part, it is entirely impossible to prevent it because of the fact that certain climatological factors enter into the problem. The most prominent factors inducing water core are:

(1) O'Gara, P. J. Water Core of Apple. Office of the Pathologist and Entomologist for Rogue River Valley, Medford, Oregon. Bulletin 9. October 11, 1912

* North Carolina Experiment Station Bulletin No. 206.

1. Excessive or strong vegetative growth, especially in young trees just coming into bearing. Such trees usually set light crops and the fruits are abnormal in size. Fruits borne far out on the terminals are very liable to water core, whether the trees are old or young, providing the trees are vigorous. Trees making poor growth, which may be caused by soil conditions, lack of moisture, root trouble, or any other cause, rarely show water core in the fruit.

2. High cultivation is a factor, but alone would not cause the trouble. However, well cultivated soils retain moisture much better than those which are not cultivated, hence, as a rule, high cultivation will promote vigorous growth and, therefore, favors water core, providing other factors are present.

3. Excessive precipitation or irrigation shortly before the maturity of the fruit if followed by great extremes of temperature and atmospheric humidity, are factors of the greatest importance. During hours of sunshine the moist ground is warmed to such an extent that water is readily taken up by the root system, and at this time transpiration is also very rapid. During the night the atmospheric temperature lowers to the point of saturation, this often being very little above the freezing point; however, the moist soil in which the roots are growing remains warm, or at least several degrees above that of the air temperature. Under such conditions, sap pressure is continuous, but transpiration is checked. Evaporation cannot take place from any surface when the surrounding medium (air, in this case) has reached the point of saturation. With transpiration checked and the sap pressure continuing, the tissues along the lines of greatest pressure must give way. These tissues are found in the fruits, especially those farthest out on the terminals, because they are exposed to extremes of temperature. Fruits on the south or southwest sides of trees are always most affected.

4. Severe pruning shortly before the ripening period, or defoliation by disease or otherwise, thus causing the fruit to be exposed as well as reducing the evapora-

tion surface of the tree, will have a tendency to produce water core.

5. Frosts, which are severe enough to injure the foliage, have an effect similar to that of defoliation, since leaves which are so injured no longer function as true agents of transpiration. Certain chemical activities are also set up in plants after frosts have injured them, and this produces rapid ripening in the case of apples. It is quite noticeable after a heavy frost that apples color rapidly, this being due to the formation and activity of certain enzymes.

6. Cell tension or turgor may be induced by the rapid conversion of starch into sugar. This tension may be caused in two ways: (1) by the rapid absorption of water by the sugar through osmotic pressure; (2) by the rearrangement of the molecules during the process of starch conversion into sugar. This, however, is of less importance than the other factors enumerated above.

Weather conditions favored water core during the season of 1912 in the Rogue River district. During this period practically clear weather prevailed. Beginning with August 31 and ending September 8, 1.15 inches of rain fell. Following this period of moderate temperatures came three weeks of clear weather with high temperatures during the hours of sunshine and low temperatures during the nights.

A careful examination of orchards of the same age and variety showed that the amount of water core present in the fruit was in direct proportion to the amount of precipitation or irrigation, range in temperature and range in relative humidity. Records were taken on the valley floor where the range in both temperature and relative humidity was very great. At elevations where this range was not so great, there was very little water core. The amount of precipitation also had its effect. In orchards where the precipitation was light, water core was much less abundant. A case was noted where the rainfall was supplemented by a heavy irrigation, both preceding and after the rain occurred. In this orchard over 90 per cent of the fruit

showed water core, while an adjacent orchard on the same type of soil, with the same varieties of apples, but not irrigated, showed not over 5 per cent of the fruit affected. Another case was noted where an orchard was severely pruned during the latter part of August, exposing most of the fruit. In this orchard, nearly all of the fruit became water-cored, while an adjacent orchard growing under the same conditions, but unpruned, had very little water core. Another orchard where one-half the trees were pruned, as above, showed 90 per cent water core in the part pruned, while the unpruned trees did not show more than 5 per cent.

As has been stated before, water core is more liable to occur in exposed fruits, especially those far out on the terminals and those on the south or southwest parts of the tree. In order to prove that this is universally true, I had a large number of boxes of fruit picked from the south and southwest parts of trees by pickers who did not know my purpose. I also had fruit picked from the unexposed parts of trees. In the former case, fully 90 per cent of the fruit showed water core, while less than 5 per cent were found to be water-cored in the latter case. This proved to be a very important matter in the segregation of water-cored fruits preparatory to boxing for shipment.

The examination of water-cored fruit shows that it is water-cored in proportion to its exposure to extremes of temperature and humidity. The side or part of an apple presented to the direct action of the sun's rays will show more water-soaked tissue than the part not so exposed. In the orchard, or even with the fruit in the boxes, the careful observer may pick out the water-cored fruit, although no evidence of water-soaked tissue may be seen. Usually, water-cored apples have a much higher color than those not affected. In the Newtown, a yellow variety, a blush or colored cheek usually indicates a water-cored fruit. A normal Newtown should be green when picked. Water core is much more easily detected in yellow than in red varieties of apples.

In both sections of the fruit the parts marked *v* are vascular bundles, which are ten in number. It will be noted in the cross section that the upper bundles show smaller areas of water-soaked tissue than the lower bundles which have rather large areas surrounding them showing a water-soaked appearance. In the region marked *c* of the cross section there are large areas of water-cored tissue, the injury extending outward to the epidermis. The water-soaked area is on the side of the fruit presented to the direct rays of the sun, while the upper

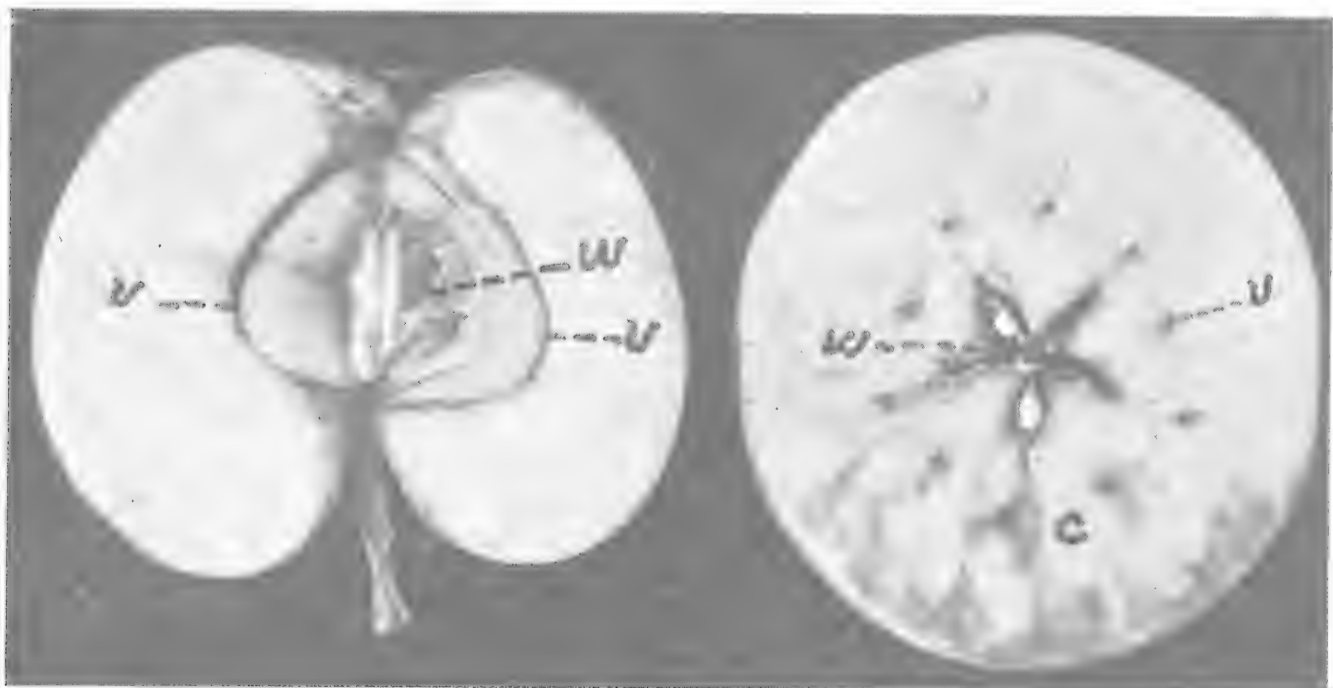

Fig. 1. Longitudinal and Cross Section of Newtown Apple Affected with Water Core

side, showing practically no water core, is on the side away from the sun. The cracked carpel with its hairy growths is shown at *w*. It is best seen in the longitudinal section, which also shows very plainly the connection of the vascular strands marked *v* with the stem. This fruit was taken from a terminal on the southwest side of a vigorous ten-year-old Newtown tree, and did not outwardly show water core.

Under proper storage conditions, water-cored fruit, unless badly affected, will entirely recover. This will be the case where no liquid fills the seed cavities and if the fruit is placed in a cool, even-temperated place (not cold storage). The fact that water-cored fruit will become normal, the water soaked spots entirely disappearing under proper storage conditions, demonstrates the non-parasitic nature of the trouble. As soon as it is found that apples are becoming water-cored, they should be immediately picked and placed in proper storage. If allowed to remain on the trees until liquid fills the seed cavities, ultimate recovery is almost impossible. Besides, various organisms gain access to the fruit and complete its destruction.

*In an experiment, 1,000 boxes of Newtown apples showing fully 90 per cent water core were stored for about three weeks. The percentage of water core was carefully determined before putting the fruit into storage. As far as possible all fruits very badly water-cored and evidently having the seed cavities filled with liquid were not put into storage. At the end of three weeks the fruit was again examined and showed scarcely 1 per cent water core. The only cases not fully recovering were those in which the seed cavities had become filled with liquid, and in which fermentative processes had been set up.

MEDFORD, OREGON.

* During the fall and winter of 1912-13 the Richey-Gilbert Co. stored 10,000 boxes of water-cored apples, grown in the Yakima Valley. They were removed late in the storage season with a loss of only 0.3 per cent. Mr. Gilbert states: "I think it can be announced with some certainty that water core does not mean ruin to the apples."—Ed.

Important References Bearing on Water Core

1. Handbuch Pflanzenkrankheiten, 1:142. 1886, Sorauer.
2. Handbuch Pflanzenkrankheiten, 3rd. Edition, 1909, Sorauer.
3. Zeitschr. Pflanzenkrankheiten, 5:8. 1895, Aderhold.
4. Bull. Soc. Bot. France 33:600. 1896, Prillieux.
5. Bulletin No. 39:61. 1892, Purdue University, Agri. Exp. Sta.
6. Report Canada Exp. Farms for 1896: 172.
7. Bull. No. 214:374. 1910, Ohio Agri. Exp. Sta.
8. Bulletin No. 235, 1903, N. Y. Agri. Exp. Station.
9. Bulletin No. 61, 1893, Cornell Univ. Exp. Station.
10. Bulletin No. 94, 1905. Bureau of Chemistry, U. S. Dept. of Agri.
11. Technical Bulletin 1, 1909. Transvaal Dept. Agri.
12. Country Gentleman 68: 1084, 1903.
13. Phytopathology, Vol. 1, No. 4; 126, 1911, Norton.
14. Bulletin No. 9, 1912. Office of the Pathologist for Rogue River Valley, Medford, Oregon.

WINTER DESICCATION. See *Rosette*.

Winter Injury Also Called Sun Scald

There are a number of evidences of injury which involve the trunks of apple trees of all sizes; they are many times due to freezing injury; while this name winter injury appears at the beginning of the paragraph, and while the name sun scald has been applied for a long time to similar conditions, the injuries are directly due to freezing, sometimes occurring in winter and sometimes due to premature low temperatures when the trees are gorged with water (sap) and there is stimulus to excessive water absorption and no tendency to hasten ripening of tissues through water loss and reduced water content such as occur in dry autumn periods. It is evident that where we have such excessive water supply in the inner bark and in the process of freezing, a layer of ice crystals is



Fig. 1. Winter Injury to Young Apple Tree.

formed. There is great danger of separation of the bark layer from the wood at that time as at others. The sun exposed side seems to suffer worse by reason of the more extreme temperature changes which were incited on these exposures. It is evident that warm periods in winter are a source of danger when followed by low temperatures.

Upon very large trunks near the base, as on Grimes and some others, this may be the real explanation of frequent sun scald or basal injuries. Wherever such an injury begins there is risk of the intrusion of wound fungi with all the consequences which follow their entrance. The handling of winter injuries must, so far as prevention goes, precede the conditions which cause it. Where possible the

prevention of excessive late growth is desirable. In cases of orchard trees it may be that mulches of coarse litter, especially, will prove serviceable. It may be added that this injury to woody growths is a less developed phase of the killing back of herbaceous plants by the premature frosts.

Another phase still is the killing back of branches at the tips of woody growth which are not strictly hardy in our climate. In the case of our Japanese plum and of some ornamental shrubs, this is a frequent phenomenon and its cause is to be sought in the same factors above described. Growth being protracted late in the season, these water-gorged terminal twigs are killed by the subsequent winter freezing whenever this is severe.

See *Sun Scald*.

A. D. SELBY

Winter Injury and Cankers

Ben Davis and Gano apple trees died in such large numbers throughout Iowa during 1912 season that the Iowa Agricultural Experiment Station Horticulturists, S. A. Beach and Lauren made a thorough investigation of the districts most affected. In their preliminary report they say that injury and death of these fruit trees is due to a number of factors, chief of which are cankers and blight caused by various parasitic diseases; the early fall freeze of October, 1909; the late spring freeze of April, 1910; the dry season of the summer of 1910, followed by the cold winter with comparatively light snow, and the extreme drouth and heavy crop production of 1911.

All of these factors tended to weaken the vitality of the apple trees, and particularly of the older and less vigorous ones, rendering them less able to withstand the unusual and continued low temperatures of last winter. Those orchards which had been well cared for are showing less injury than neglected orchards and their trees are recovering more rapidly. Also, the younger and more vigorous trees recovered more rapidly; they were also less injured.

In general, those trees which were

previously weakened by disease or mechanical injury showed the most winter killing. This was especially true in Fremont, Pottawattamie, Mills, Iowa, Polk and Page counties, south of the Rock Island railway, where no cases of injury found was traceable to winter killing alone. Here the blister canker or Illinois canker was the most common cause of injury and it is considered by the experiment station as a very serious menace to Iowa orchards. In a recent bulletin issued by the station on new fungus



Fig. 1. Canker on Young Tree. Due to Winter Injury.
(Purdue Experiment Station.)

growths in Iowa, No. 131, there is a description of this disease. In Harrison and Woodbury counties, winter's severe cold is the chief cause of trouble.

Where orchards are afflicted with canker or other disease, the diseased wood should be cut out. That should be done at once. The cuts should extend back well into the healthy bark and wood. The wounds should be thoroughly cleansed and disinfected with any good disinfectant, as formalin, corrosive sublimate, copper sulphate, Bordeaux mixture, or lime sulphur, and then covered with paint.

Where the trees have been weakened, provide them with a generous and continuous supply of food and the soil moisture necessary to make the food available to the tree. This can be done by breaking up the land and keeping the soil well tilled so as to form a dust mulch at least three inches deep. Whenever possible, apply manure, especially where the soil is too steep for cultivation. This will add fertility and helps to conserve moisture. This treatment will bring many trees back into good condition and, while they may not produce apples this season, its beneficial effects will continue for a good many years later.

S. A. BEACH,
Ames, Ia.

Wounds

No artificial medium can be applied to the surface of a wound which will induce it to heal more quickly. The activity of the healing process depends upon the character and position and the time of year when the wound is made rather than upon protective coverings.

Large wounds which result from the removal of branches of considerable diameter, leaving a large surface of heartwood exposed, may with advantage be protected by painting the cut surface with a heavy coat of white lead, the sole object of this precaution being to protect the heartwood from decay until the new growth, which forms from the growing tissue immediately under the bark, has had time to develop over the exposed dead wood and protect it from decay.

A large number of waxes, paints and washes have been tried, and the conclusion of the whole matter may be summarized in the statement that any substance which is not corrosive or detrimental to growth which will protect the heartwood from the attacks of rot spores will prove a satisfactory covering for a cut surface. Among such substances may be mentioned white lead, yellow ocher, coal tar, and grafting wax.

L. C. CORBETT,
Washington, D. C.

YELLOW LEAF. See *Rosette*.

**DISEASE SUSCEPTIBILITY OF APPLE
VARIETIES IN OHIO**

A. D. SELBY

*Botanist, Ohio Agricultural Experiment
Station, Wooster, Ohio*

The tabular matter prepared under this heading is designed to answer many of the usual questions with regard to susceptibility or disease resistance of this or the other apple variety under Ohio conditions. It was originally suggested by Prof. W. J. Green, horticulturist of the Ohio Agricultural Experiment Station, who has assisted freely in its preparation. J. B. Keil, assistant horticulturist, has also contributed freely with his experience in the orchard. I am under similar obligations to Prof. Wendell Paddock, professor of horticulture, Ohio State University, Columbus, and to numerous

growers for extracts from their notebooks.

The plan of the table is to specify in each column opposite the name of the variety, the observed susceptibility or resistance to the disease named in the column. The general behavior of the varieties included has been under observation for a varying number of years, according to the newness of the variety, and while it is to be presumed that variation in behavior with respect to disease susceptibility actually occurs, the forms of statement used in the table are designed to include this variation where known.

The usefulness of the table will be best realized by rejecting the varieties showing serious weaknesses or susceptibilities and endeavoring to group those having the maximum number of good grades with respect to disease susceptibility.

DISEASE SUSCEPTIBILITY OF APPLE VARIETIES IN OHIO—BY A. D. SELBY

Variety	Diseases					
	Crown Gall	Collar Rot	Blister Canker	Twig Blight	Scab	Bitter Rot
1 Arkansas (Mam. Blk. Twig)	Moderately	?	?	Slightly	Rather seriously	Moderately suscep.
2 Arkansas Black	Slightly		?	Slightly	Seriously	?
3 Babbitt			?	Almost immune	Somewhat suscep.	?
4 Baldwin		Moderately—South		Slightly	Very slightly	Very slightly
5 Baltimore				Very suscep.	Very slightly	Very slightly
6 Bellflower			?	Rather suscep.	Somewhat suscep.	?
7 Bentley-Sweet		Moderately	Probably suscep.	Moderately	Very slightly	Very suscep.
8 Ben Davis	Occasionally	Moderately	Very suscep.	Moderately	Very slightly	Quite suscep.
9 Canada Red	Quite suscep.			Very slightly	Quite suscep.	Quite suscep.
10 Delicious				Nearly immune	Very suscep.	
11 Early Harvest	Seriously		?	Very suscep.	Very suscep.	Somewhat
12 Esopus Spitzenburg			?	Rather suscep.	Very suscep.	
13 Gano			Probably suscep.	Moderately	Very slightly	Quite suscep.
14 Grimes Golden		Very suscep.—South	Quite suscep.	Not seriously	Not seriously	Quite suscep.
15 Greenville		?	?	?		
16 Hubbardston		Moderately			Somewhat	Moderately suscep.
17 Jonathan	Very suscep.	Moderately	?	Very suscep.	Slightly	
18 King David	?	?	?	Very slightly		
19 Maiden's Blush	Moderately	Very suscep.	?	Quite suscep.	Very suscep.	Quite suscep.
20 Mann			?	Moderately	Slightly	?
21 McIntosh	Seldom			Sometimes suscep.	Very suscep.	
22 Newtown Pippin		Very slightly		Quite suscep.	Very suscep.	Moderately
23 Northern Spy	Very suscep.	Rather suscep.—South	Somewhat	Quite severely	Very suscep.	Very suscep.
24 Oldenburg		?	?	Sometimes	Somewhat suscep.	
25 Rambo	Moderately	Very slightly	Rather suscep.	Slightly	Very suscep.	Very suscep.
26 Rome Beauty	Occasionally	Slightly suscep.	Quite suscep.	Slightly	Very suscep.	Slightly suscep.
27 Rhode Island Greening	Moderately	?	?	Very suscep.	Slightly	Moderately
28 Salome	Moderately	?	?	Moderately		Very suscep.
29 Sutton Beauty		Very suscep.	?	Very suscep.	Quite suscep.	?
30 Stayman's Winesap	Moderately	?	?	Moderately	Very suscep.	?
31 Stark	?	?	?	Very suscep.	Slightly	?
32 Smith's Cider	Very suscep.	Very slightly	Not seriously	Very suscep.	Very suscep.	Moderately
33 Tompkins King	Moderately	Very suscep.		Very suscep.	Somewhat	Moderately
34 Wealthy		Very slightly	?	Slightly	Very slightly	Slightly (?)
35 White Pippin		Very slightly	?	Not suscep.	Moderately	Slightly
36 Winesap	Moderately	Quite suscep.		Slightly	Seriously	Occasionally
37 Yellow Transparent	Occasionally			Rather suscep.	Quite suscep.	
38 York Imperial	Moderately	?	?	Slightly	Moderately	

Variety	Diseases				Special Weaknesses
	Blotch	Black Rot of Fruit and Canker	Physiological Fruit Spot or Baldwin Spot	Fungus Fruit Spot Phoma (<i>Cyhdresporium</i>) pomii	
1 Arkansas (Mam. Blk. Twig)		?	Occasionally	Slightly	Good tree.
2 Arkansas Black		Slightly suscep.	Seldom	After maturity	Scab susceptibility.
3 Babbitt		Slightly	Seldom	Moderately	Late and biennial bearing; winter injury.
4 Baldwin	Very slightly	Moderately	Very suscep.	Occasionally	
5 Baltimore				Occasionally	
6 Bellflower		Moderately suscep.	Sometimes seriously	Moderately	Lack of fruitfulness.
7 Bentley-Sweet	?	?	Not suscep.	After maturity	Susceptible to bitter rot.
8 Ben Davis	Rather suscep.	Rather suscep.	Not suscep.	Very slightly	Susceptible to blister canker.
9 Canada Red		Very suscep.	None	Moderately	Susceptible to black rot.
10 Delicious		?	Not suscep.	Slightly suscep.	Good tree.
11 Early Harvest		Slightly suscep.	Sometimes	Moderately	Crown gall and scab.
12 Esopus Spitzenburg		Very suscep.			Splitting of crotches and sun scald.
13 Gano	Rather suscep.	?	Not suscep.		
14 Grimes Golden	Rather suscep.	Quite suscep.	Frequently	Seriously	Susceptible to collar rot.
15 Greenville	?	Quite suscep.	Very seriously*	*	Storage scald and fruit spot
16 Hubbardston		Serious on mature fruit.	Seldom	?	
17 Jonathan		Slightly suscep.	Occasionally	Very seriously	Poor growth when young; weak limbs when old.
18 King David		Slightly suscep.	Very suscep. 1912	Moderately	Water core and physiological spot.
19 Maiden's Blush	Frequently	Very slightly	Not suscep.	Very suscep.	Weak root system.
20 Mann	Very suscep.	Quite suscep.	?		
21 McIntosh		Sometimes suscep.	Seldom	Occasionally	Inclines to drop before mature.
22 Newtown Pippin	?	Quite suscep.	Not suscep.	Probably suscep.	Scabs badly.
23 Northern Spy		Very suscep.	Very suscep.	Moderately	Late bearing.
24 Oldenburg		Cankers frequently			Good tree.
25 Rambo	Occasionally	Quite suscep.	Slightly suscep.	?	Scab and bitter rot.
26 Rome Beauty	Slightly	Moderately suscep.	Not suscep.	Very slightly	Storage scald.
27 Rhode Island Greening	Slightly	Moderately suscep.	Occasionally	Very seriously	Twig blight.
28 Salome		Very suscep.		Very suscep.	Shriveled in storage.
29 Sutton Beauty		Quite suscep.	Not suscep.	Slightly	Twig blight.
30 Stayman's Winesap	?	Slightly suscep.	Not suscep.	Slightly	Good tree.
31 Stark	Very suscep.	Quite suscep.	Frequently	Quite suscep.	Rather late bearing.
32 Smith's Cider	Very suscep.	Very suscep.	Not suscep.		Black rot and blotch.
33 Tompkins King		Moderately	Rather seriously	After maturity, very suscep.	Collar rot.
34 Wealthy	?	Very slightly	Not suscep.		Good tree; easily injured in winter.
35 White Pippin		Quite suscep.	Occasionally	Susceptible	Good tree.
36 Winesap		Slightly	Seldom	Very suscep. after maturity	Susceptible to scab.
37 Yellow Transparent		Very slightly	Very suscep. 1912		Fair tree, too upright.
38 York Imperial		Very suscep.		Slightly	Scalding in storage.

*Spot of fruit of Jonathan adjudged as physiological not parasitic.

APPLE PESTS**Anomala***Anomala bipunctata*

Has been known to attack apple foliage in Michigan. The beetles measure about seven-sixteenths of an inch in length. They are stout and resemble their relative, the June beetle in form, also like the June beetles, they are clumsy in their movements. In color they are for the most part, polished black, except for the wing covers, which are washed with bronzy straw color, the feet and antennae being dark brown. The underside of the body is coated with fine light hairs.

Remedies

Like the June beetle, this small relative readily responds to a spray of one of the arsenites, Paris green or arsenate of lead, or any one of the reliable arsenical sprays will control it. In the case of small trees, hand picking often suffices.

R. H. PETTIT,
East Lansing, Mich.

Aphids

For the various species of plant lice, see general article on aphids.

Apple Leaf Crumpler*Mineola indigenella*

The leaf crumpler is a common insect. When the leaves are gone, the little tufts of dried up leaves attached to the silken case in which the larva passes the winter, are often seen attached to the twigs of apple trees both in the nursery and orchard. It is really common enough to do some mischief at times, but from its manner of attack it is likely ordinarily to escape attention. As it passes the winter on the trees, it is one of the insects likely to be sent out of the nursery, and doubtless has attained its present general distribution in the Eastern United States through the instrumentality of nursery stock.

The larvae occupying the cases are brownish-red in color, about one-fifth inch long, the surface everywhere opaque, with slender erect pale hairs. Head red, like the body, but paler. The first body

division with a conspicuous black neck-plate.

The pupa is formed in June and yields the adult moth in the latter part of the month and early in July. The moth is gray in general color, marked with white and black.

The best treatment for the insect is the simple process of removing the cases from the twigs in winter. In summer the only practicable treatment is spraying the leaves with arsenical poisons.

H. GARMAN,
Lexington, Ky

Apple Leaf Hopper*Empoasca mali* LeB.**General Appearance**

The presence of the insect is made known by the curling and twisting of the infested leaves, especially on nursery stock: it being primarily a nursery pest. The adult insect is pale yellowish-green in color, with white marking and is about one-eighth of an inch long. The young appear much like the adults except that they lack wings.

Life History

The winter is passed both in the adult and egg stage. The winter eggs are white, very delicate and curved in the middle. They are inserted under the bark of young apple trees (preferably under bark of two or three years' growth). These eggs hatch in the early spring so that the young nymphs and hibernating adults attack the first green foliage. During the summer, eggs are deposited in large numbers on the food plants in the leaf petioles or in the larger veins. Favorite places are the leaf petioles of apple trees and alfalfa. The position of the egg under the bark or epidermis is made known by a slight swelling of the surface.

Distribution

Throughout the United States; seldom becoming a serious pest in any locality, though occasionally it may do great damage.

Food Plants

As previously stated, the apple leaf hopper is primarily a nursery pest affect-

ing especially young apple trees, thus dwarfing them. The work is particularly on the leaves. Besides the apple it feeds upon currant, gooseberry, blackberry, pear, cherry, plum, thorn-apple, black walnut, grapes, cottonwood, elm, birch, maple, box-elder, hazel, choke-cherry, sumach, oak, syringa, snowball, canaigre, basswood, buckthorn, rose, buckeye, corn, beans, potatoes, sugar beet, clover, grasses, buckwheat, dahlia, rhubarb, hemp, alfalfa, oats, celery and hollyhock. Without doubt other plants are also attacked.

Control

The difficulty of control lies in the impossibility of killing the eggs without injuring the young trees. Successive sprayings with the oil emulsions, whale oil soap solution of one pound to eight gallons of water, or tobacco decoctions, as often as the young become apparent, will prevent serious attacks and hold the pest in subjection. Affected nursery stock should be thoroughly dipped in such solutions before shipping. To prevent attacks nurseries should not be located near orchards or fields in which the hopper breeds. All food plants should be kept out of the nursery. Sticky shields and hopperdozers may be used with good effect.

Natural Enemies

The most effective natural enemy is the small dark bug (*Triphleps insidiosus* Say), which preys upon the nymphs by puncturing their bodies and extracting the contents.

The larvae of the green lacewings also prey upon the young hoppers.

E. O. ESSIG

Apple Leaf Sewer

Ancylis nubeculana

The caterpillars of the apple leaf sewer fold the edges of the leaves together, commencing to feed inside the folded leaf sometime in July and continuing therein until the leaves fall in autumn. The larvae is greenish-yellow, with a yellow head and a horny plate of darker color just back of the head. On each side of the plate is a black dot. On each

of the remaining segments are a number of pale, shining, raised dots, from each of which springs a single hair. When full grown, the larvae line their nests with silk and fall to the ground, remaining in the caterpillar stage until next spring. Sometimes the insect becomes sufficiently numerous to cause serious damage to the foliage. The summer spraying with arsenicals for codling worm doubtless kills many. Collecting and burning the fallen leaves and other rubbish is an excellent measure.

Apple Leaf Skeletonizer

Canarsia hammondi

Nursery trees and sometimes young trees recently transplanted from the nursery are badly gnawed some seasons by a brown larva, becoming finally about one-half inch long, living, often a number together, in the grooves above the mid-ribs of the leaves under a light silken web. Sometimes it draws several leaves together and lives concealed among them. This insect feeds upon green substance of the leaves only, leaving finally only the veins and veinlets, the foliage at a distance then appearing as if scorched by fire. Whole blocks of young trees in the nursery may become thus injured. In the orchard it is less often seen, and then appears most frequently on rather young trees.

This insect is well known in the upper Mississippi valley from its injuries to apple trees, but eastward appears to be less well known.

The larva reaches one-half inch in length and may be recognized by four round black dots back of the head. The moth is slate gray, measuring about a half inch from tip to tip. Paris green or arsenate of lead in good season will kill them.

H. GARMAN

Apple Maggot or "Railroad Worm"

Rhagoletis (Tryeta) pomonella Walsh

The apple maggot, as the name implies, is the larva of a fly or dipterous insect, and belongs to the family Trypetidæ, which group contains numerous other fruit-infesting maggots, some of them

very serious pests, and, from their structure, mode of life, and feeding habits, very difficult of control. Apples injured or "railroaded" by the apple maggot show discolored winding burrows, or tracks, and cavities here and there in the flesh, and when infested with several larvae the pulp will be usually quite honey-combed with their burrows and more or less broken down into a yellowish mass, merely held together by the skin.

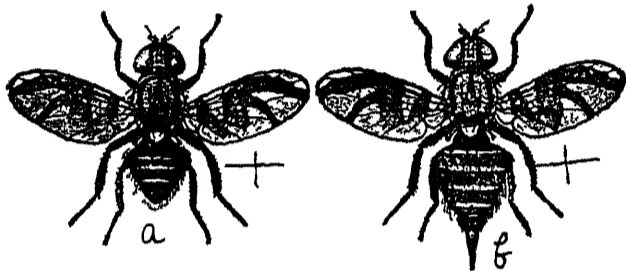

Fig. 1. Flies of the Apple Maggot
a, Male; b, female—enlarged.

Distribution

The apple maggot is a native American species, its natural food being haws (*Crataegus*), and in at least one instance it has been bred from crabapples. Its feeding upon cultivated apples is thus an acquired habit, and although the insect has been reported from widely separated points in the Central and Eastern states, indicating its possible general distribution, for some reason it does not attack the apple throughout its range, but only in certain localities and portions of the country. Of apples, sweet and sub-acid summer varieties are worst attacked, but fall and winter sorts are also infested, including distinctly acid varieties.

Preventive Measures

The apple maggot has proved to be an unusually troublesome insect to combat successfully. The eggs are deposited beneath the skin of the fruit, within which also the larva feeds until full grown. The pupal stage is passed just under the soil, or around the roots of grass in sod land, and the flies do not feed in a way to permit of their destruction. Spraying with arsenicals, so effective against the codling moth or apple worm, is for this pest quite useless.

The insect, however, may be attacked in two important ways. As stated, the

larvae do not leave the fruit until the latter has ripened and fallen to the ground. The prompt gathering and destruction of the windfalls, before they are deserted by the maggots, would serve to keep the insects greatly reduced, amounting to practical extermination if thoroughly carried out. This practice has long been recommended by entomologists, and comprises the most effective measure of controlling the pest at present known.

A. L. QUAINANCE,
Bureau of Entomology, Bulletin 101

Apple Tree Measuring Worm

Ennomos subsignarius

Two brown or black looping caterpillars occurring on apple trees are not always discriminated by fruit growers, who speak of both as canker worms. The species here treated is sometimes very common and may defoliate whole orchards at times, but its larvae is so much like that of the true canker worm that one might be excused for failing to recognize the differences. The adult moths, however, are very different, though the insects are members of the same family. They are leaf feeders and so may be controlled by arsenical sprays.

Apple Red Bug and False Apple Red Bug

Heterocordylus malinus Reut.

Lygidea mandax Reut.

Two species of red bug have been reported from New York. These leaf bugs are a brilliant tomato red in their immature stages. The first appearance of the bugs is detected by the red dots on the foliage caused by their feeding punctures.

The eggs are laid in late June or early July. The nymphs pass through five moults, the wings appearing with the fifth moult.

Injury to the fruit is caused by the punctures of the young nymphs while feeding upon the small fruit. These punctures sometimes reach to the center of the apple. Apples thus injured sometimes fall and those which remain on the trees until maturity are spoiled for market, on account of their rough, nobby

appearance. Other sucking insects produce the same sort of injury.

Spray with "black leaf 40" diluted one to 800, just before the fruit buds burst. A later spraying, if necessary, may be made at the time of the calyx spray for the codling moth when the tobacco mixture may be added to the arsenate of lead.

Apple Seed Chalcis

Syntomaspis druparum

Minute black dots in more or less distinct depressions of malformed or knotty apples may be due to the work of the apple seed chalcis. A brownish line of hardened corky tissue may extend from the spot to the core, if this insect is responsible for the mark. Some of the sucking insects make very similar external marks upon the fruit. This insect infests the seed in the larval stage, the initial puncture having been made when the fruit was so small that the ovipositor of the female could reach through the pulp to the young seed. Some injury is done to the texture of the pulp and the seed will be of no use for planting. Wild crabapples and seedlings seem most liable to attack. Destruction of all fallen fruit in the fall and of wild crabapple trees and seedling trees will control the insect whenever it becomes sufficiently important to justify such measures.

H. A. GOSSARD,
Wooster, Ohio.

Apple Tingis

Corythuca sp.

H. F. WILSON

An insect which feeds on the under side of the leaves of apple and is often mistaken for plant lice is the above insect. It is of a shiny black color when viewed from below, the wings lie horizontally on the body, and the markings upon them are such that they appear to be made of lace. The winter is passed in the adult stage and hibernation takes place in rubbish on the ground. With the appearance of warm weather and the spreading of the leaves in the spring they leave their hibernating quarters and proceed to the under side of the leaves where the females

deposit their eggs. One of these eggs is a very interesting and peculiar object, being somewhat the shape of a truncated cone attached by the base to the ridge of the leaf, dull black in color and somewhat shriveled. When the eggs are ready to hatch the smaller end opens and the young insect comes forth and feeds on the leaf. These young feed, grow, cast their skins several times and after a time reach the adult stage as described above. Two, three, or more generations are thus produced quite rapidly. Some years they become so abundant as to do considerable harm and hundreds may be found on a single leaf. A very characteristic effect of their work is the burnt appearance of the leaves caused by the punctures made by the insects and the withdrawal of sap from them.

Remedies

This is one of the hardest insects to control, due to its seeming great resistance to insecticides which can be applied without burning the leaves. Tobacco compounds, such as black leaf, etc., probably give the best results, and should be applied about the time the young are leaving the eggs. By observation only can one tell the proper time. Continual clean cultivation is by far the best remedy.

Apple Twig Borer

Amphicerus bicaudatus, Say

This twig borer is an insect of small importance compared to many orchard pests, but is often present in apple orchards. It is a cylindrical beetle about one-third of an inch in length, of a chestnut brown color above, and black beneath. In early spring they bore into the small branches of apple, pear and cherry, entering just above a bud and working downward in the pith, evidently for both food and shelter. Such twigs soon wither and their leaves turn brown.

The beetles do not remain long in these burrows, but leave in search of grapevines or green brier, where their eggs are laid and their young reared, in the dead or dying shoots.

Exemption from injury by the twig

borer, will generally be secured when all neglected vineyards, wild grapes or brier thickets are not allowed to remain near apple orchards. The usual practice of pruning apple trees to remove all twigs injured by various agencies, is a necessary part of good orchard management and should not be neglected, although this twig borer usually deserts its burrow before such pruning can be made.

North Carolina Experiment Station.

Apple Wilt Bug

Euthoctha galeator

The tender terminal growths of apple, quince and plum trees are sometimes found to have been stung and apparently killed by a large brownish black bug somewhat resembling the squash bug. It has been noted repeatedly in nurseries, and sometimes attacks trees in the orchard.

The insect is one of the true bugs, and is provided with a strong beak with which it punctures plants to reach the sap. Like the squash bug and some other members of its order, it injects something that seems to affect the plant injuriously. Many other insects of the same group, the plant lice, for example, puncture plants, but seem to inject nothing, and the plants do not droop and wilt, though of course are finally weakened, if the insects are numerous.

The apple wilt bug is frequently seen everywhere in Kentucky, but probably feeds ordinarily on some native plant. It is capable of very severe mischief if it should become at any time more numerous than it now is.

H. GARMAN,
Lexington, Ky.

Bag Worm

Thyridopteryx ephemeraeformis

Occasional enemy of apple trees in Kentucky, Tennessee and neighboring states.

A naked caterpillar which constructs and carries about with it a tough, gray, silken case over the outside of which it fastens fragments of leaves. The adult male is a small, black moth with transparent wings. The females are wingless and deposit their eggs in their pupa cases left hanging to twigs. The eggs are deposited in September and October.



Fig. 1. Adult Bag Worm, Male. Also its case and pupa case. (Tennessee Experiment Station.)

Control

Destroy the pupa cases. Spray with arsenate of lead.

BARK BEETLE. See *Fruit Tree Bark Beetle*, this section.

BLACK SCALE. See *Olive*.

BLISTER MITE, LEAF BLISTER MITE, PEAR LEAF BLISTER MITE. See under *Pear*.

BORERS

Apple Bud Borer

Steganoptycha pyricolana Murt.

Young apple trees have been considerably injured by small caterpillars boring into the terminal buds and thus stunting their growth. Upon trees top-worked by budding the shoots from the buds are often seriously injured. Only the "water sprouts" are attacked upon old trees. These caterpillars ultimately transform into small moths, which lay eggs for another brood. Four broods occur in a season, about six weeks being required for each. During the winter the caterpillars hibernate in their burrows in the twigs and in small silken cases on the branches. They may thus be spread on nursery stock. The best means of control is by pruning off infested terminals in winter, keeping "water sprouts" cut off old trees, and frequent spraying with arsenites.

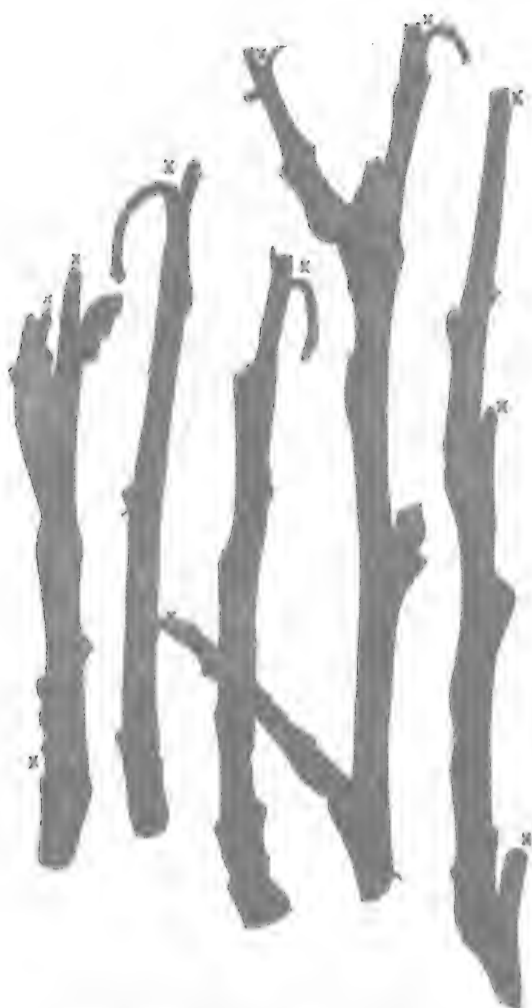

Fig. 1. Terminals of Young Apple Trees, Taken During the Winter. Hibernating Bud Borers were found at x, x, x, often at the base of a leaf stem. (Delaware Experiment Station.)

The bud borer has a wide distribution. It seems to be held in check, however, by a natural enemy in the form of a small fly.

Apple Twig Borer

Amphicerus bicaudatus, Say

Attacks apples, pears, cherries, and other trees, and bores into the twig just above a bud for food and shelter. The beetle which does the damage is about one-third of an inch long, cylindrical in form, brownish above and black underneath.

Remedies

The remedy that is recommended is to look for the infested twigs, cut them off and burn them. See also page 505.

Branch and Twig Borer

Polycaon confertus Lec.

H. F. WILSON

Although apparently never doing any amount of damage this insect is often found attacking the stems and branches of pome fruits and even grapes. Nothing

is known of its life history in Oregon, but in California the larvae work in live oak trees and it is very likely that they do the same here. The adult beetles start in to burrow above the buds and excavate a shallow burrow downwards, rarely deeper than the length of the body. This burrow is about one-fourth inch in diameter and why it is made is not known unless it is for the purpose of feeding, as they apparently never deposit eggs in them.

They have never been abundant enough to cause any great alarm, but the burrows offer excellent opportunity for the entrance of fungi and decay organisms.

There is no known method of prevention.

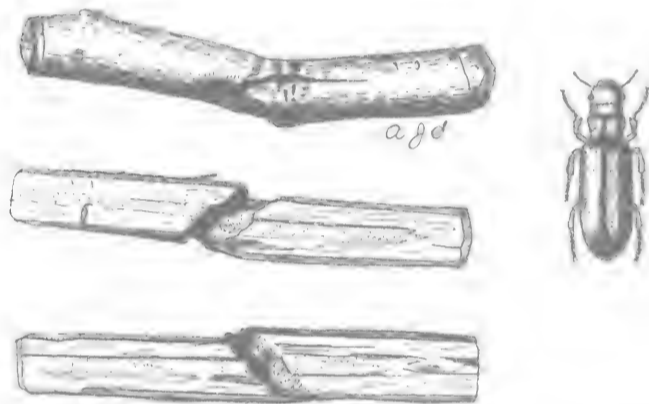

Fig. 1. The Branch and Twig Borer. Adult and work on young twig. (Original)

Flat-Headed Apple Tree Borer

Chrysobothris femorata Fab. Family Buprestidae

General Appearance

The adult beetle is oblong, flattened and the body color metallic greenish black. On each wing cover are three raised longitudinal lines which are traversed by two brass-colored depressions, dividing the surface into three nearly equal dark areas. The underside is metallic copper, and the feet green. The eggs are yellow, ribbed, but one-fiftieth of an inch long and oval in form with one end flattened. The mature larvae are dark yellow and without legs. The anterior portion, just behind the head, is enormously enlarged and flattened, giving the insect its common name, though in reality the head proper is very small and easily distinguished by the black jaws. The pupa is first white, but

becomes darker until it assumes the color of the mature beetle.



Fig. 1. The Larvae of the Flat-Headed Apple-Tree Borer (*Chrysobothris femorata* Fab.), and their work on young apple trees. (Original)

Life History

The eggs are fastened with a cement in the crevices and under the loose scales of the bark, either singly or in groups. After hatching the small grubs bore into the sapwood upon which they feed. Young trees may thus be completely girdled by their wide flattened burrows. As the larvae develop they work into the older and firmer wood. When ready to pupate they work upward to the bark, eating nearly through. After pupation the adults emerge early in the spring and begin egg laying. The trees selected are usually unhealthy or are afflicted with wounds and sunburns. Upon or around such affected places the eggs are laid. The presence of the larvae in healthy tissue may be told by the discoloration of the bark and the exudation of sap from the burrows.

Distribution

Throughout the entire United States.

Food Plants

Especially injurious to weak or wounded trees, but occasionally attacks young nursery stock. It is especially destruc-

tive to the apple, but also attacks the pear, plum and occasionally the peach and raspberry.

Control

Though this pest burrows in the trunks and limbs of large trees it is most destructive to young trees, the bases of which are often completely girdled. Therefore young trees should be protected from sunburn and injury to prevent attacks of the borer. A very good preventive is to paint the trunks and larger limbs with a solution prepared by reducing soft soap to the consistency of paint, by the addition of a strong solution of washing soda in water. This should be applied early in the spring (May or June) and again in the middle of the summer (July or August). The young burrowing larvae may be destroyed with a knife-blade or crooked wire.

Natural Enemies

Internal parasites play an important role in the control of this pest in the East. A small chalcid and two ichneumonid parasites (*Bracon charus* Riley and *Cryptus gallator* Say), prey upon the larvae, while woodpeckers also dig out great numbers of them.

The work of these natural enemies is responsible for its not doing more damage.

E. O. ESSIG

Fruit Tree Bark Borer

Euzophera semifuneralis Walk.

The larvae bore into the bark of apple and plum and related trees, not entering the wood. Trees are sometimes girdled by them. Distributed over the United States. The borers pass the winter in silken cocoons beneath the bark; their cocoons quite closely resemble those of the codling moth. About May 1 the caterpillars change to pupae and the adults emerge late in May or early in June. There appears to be a second brood, the moths appearing the last of September.

The larvae are about one inch long and are quite variable in color but for the most part of a dark pink or reddish color.



Fig. 1. The Fruit Tree Bark Borer. a, caterpillar or borer from above; c, same from below; b, adult moth—all enlarged. Delaware Experiment Station.

The moths fly at night and are rarely seen. The wing expanse is about an inch. The head and body are dusky gray while the fore wings are a dusky gray with brownish-red and black markings. The hind wings are smoky.

Remedies

The borers are most commonly found boring into wounds, cracks of the bark, cut ends of branches, etc. Such abrasions should, therefore, be cut as smooth as possible and then be well painted.

Infested trees with loose and cracking bark should be well scraped during the winter, thus destroying many of the hibernating borers, as well as many other insects with similar habits (such as the codling moth). Trees with smooth bark are also less likely to be again attacked. The borers will not all be caught by scraping, however, and the trees should be carefully gone over and all borers cut out before May 1. Washing the trunks and lower branches of the trees with whale-oil soap or thick caustic soft soap, to which has been added one pint of crude carbolic acid to every ten gallons, which is used as a repellent against the apple tree borer beetle, may also prevent the moths from depositing their eggs on trees so treated. Such washes should be applied before the middle of May and will be of value in repelling other boring insects.

Subsequently during the summer the borers should be cut out as often as observed, which can be easily and quickly done, as they never penetrate the sap-

wood and their presence is usually noticeable by the borings thrown out at the surface of the bark.

Round-Headed Apple Tree Borer

Saperda candida Fabr.

This is a very injurious beetle to the apple trees. The adult insect measures about three-fourths of an inch long, is brown and has two broad white stripes extending the length of the body. The eggs are laid on the bark near the base of the tree during the summer. The larvae, which are white with round heads and black jaws, hatch within a short time and immediately they begin to bore into the interior of the tree. It takes three seasons for the larvae to reach maturity; the beetles come out during the summer.

Remedies

The larvae may be detected first by the discoloration of the bark and later by the castings which have been pushed out of the burrows. The most effective remedy, as for the other tree borers, is the digging out method. Of course this means the making of additional wounds on the trees which in some cases may be as bad as the borers. Protecting the trunk of the tree to prevent the laying of the eggs by the females is recommended. Mosquito netting wrapped about the trunk is said to be satisfactory.

Measures used against the peach tree borer ought to give just as good satisfaction with the round-headed apple tree borer.

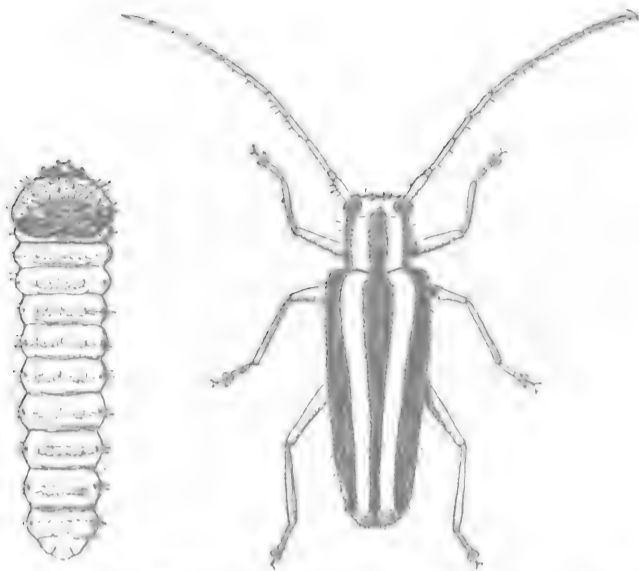

Fig. 1. Round-Headed Apple Tree Borer. Larva and female beetle. (After Chittenden)

Spotted Apple Tree Borer

Saperda cretata Newm.

Related to the round-headed borer and similar in appearance except that it has two white spots on each wing case.

The species is quite widely distributed having been found from Michigan to Texas.

Remedies the same as for round-headed borer.

Bronze Apple Tree Weevil

Magdalis aenescens Lec.

H. F. WILSON

Like many of the common insects found in Oregon, this insect appears to be a native of the Northwest, and has only been reported from Oregon, Washington and British Columbia. When first noticed, it was reported as destroying whole apple orchards, but later observations show that most of the feeding occurs in the bark. In many instances the bark appears to be dead before the weevils



Fig. 1. The Bronze Apple Tree Weevil; showing egg cells in bark of apple. (Original)

make their egg punctures, but it has also been noticed that healthy bark affords suitable places for egg deposition and several growers in the Willamette valley report serious injury to apple trees.

If one notices the egg cells, as shown in Fig. 1, and cuts away the bark, the larval galleries can be easily traced to where the larvae are feeding.

The egg cells are made by the female weevil, which eats out circular burrows to a depth of .08 inch. The eggs are then deposited singly in a few of the pits and the young white larvae hatch from these in a week or two. They feed and develop in these burrows until fall, when the larvae hibernate over, pupate in the spring and change to adults.

The adult insect is an elongate bronze black beetle, measuring about one-fifth inch in length.

Methods of Control

Careful examination of trees in localities where this insect is found and cutting out the infested areas appears to be the most satisfactory method for combating this pest.

Brown Tail Moth

Euproctis chrysorrhoea Linn.

H. F. WILSON

Accidentally introduced into this country along in the nineties on nursery stock imported from Holland; the brown tail moth has become one of our worst insect enemies of orchard, forest, ornamental and shade trees.

Not now present in the Northwest but over wintering nests have been brought in on nursery stock and there is danger of its becoming a pest.

The eggs hatch during August and the larvae live over winter in nests of leaves drawn together by silken threads. The eggs are globular in shape and quite small; they are laid in masses on the under side of the leaves along in late July and early August. Each mass contains approximately 300 eggs, is brown in color and covered with numerous brown hairs taken from the body of the moth. The egg masses measure two-thirds of an inch in length by one-fourth

inch in width. The larvae when first hatched are black with reddish-brown hairs dorsally placed; on the fourth and fifth segments one may find a single large tuft of brown hairs, and on the middle



Fig. 1. Brown Tail Moth and Larva.

line of the ninth and tenth segments is a reddish tubercle which may be withdrawn into the body.

When full grown the larvae measure about two inches in length, are reddish-brown in color with two red spots on the back near the rear end, and with a longitudinal row of white markings on each side of the abdomen. The body is also covered with numerous tubercles bearing long barbed hairs. The tubercles along the back and sides of the abdomen are thickly covered with short brown hairs in addition to the longer ones. These short hairs are the ones known as the "nettling hairs."

About the middle of June the larvae spin silken cocoons among the leaves and then pupate. Here they remain for about 20 days, and begin to appear as moths about the middle of July. Both the males and the females are pure white, with the exception of the abdomen, which is brown at the tip; on account of these brown tips the moth is known as the brown tail moth. The females have a wing expansion of about one and one-half inches, the males one and one-third inches.

As soon as they have copulated the females begin depositing the eggs on the under side of the leaves. These hatch in about three weeks and the young larvae

immediately begin feeding on the leaf bearing the egg mass. After a short time they wander to other leaves and feed, returning to the old leaf at night. Toward fall they begin forming the winter web in which they leave exit holes so that they may go out and feed during good weather.

The Principal Means of Distribution

The principal means of distribution to any distance is made by the importation of nests on nursery stock. Having once established themselves they have but little difficulty in getting from orchard to orchard, as both males and females are strong fliers. It is said that they have a habit of soaring above the tree tops and buildings and so are carried long distances by the wind. They are also attracted to lights and so are distributed by trains and electric cars into which they fly when opportunity offers.

Food Plants

Pear and apple are the favorite food plants of this insect, but nearly all fruit and shade trees, excepting the conifers, are attacked.



Fig. 2. Pupa Cases of Brown Tail Moth.

Methods of Control

Collecting and destroying the winter nests seems to be the best method and supplemented with spraying for the newly

hatched young offers a means whereby this insect can be held in check. Uninfested trees can be protected by applying bands of some sticky substance as tangle-foot or tarred bands.

Natural Enemies

[For several years past the government entomologists have been importing various species of parasitic flies and predacious beetles which, in the native habitat of the moth have served to hold it in check. After some years of waiting these



Fig. 3. Chalcis Fly, Enemy of Brown Tail Moth.

parasites have at length increased to such numbers as to begin to have an appreciable effect in controlling the moth and may eventually reduce their number.—Ed.]

Buffalo Tree Hopper *Ceresa bubalus* Fab.

H. F. WILSON

This insect is quite common throughout the United States and may do considerable damage when abundant. The common name applied to the adults is given on account of an imaginary similarity in shape to a male buffalo. The mature insect is grass green in color, triangular in shape and with the pronotum projecting strongly into sharp points in front. The summit of the pronotum forms a longitudinal line extending on a slant to the tip of the abdomen.

The injury done by this insect is caused by the cutting of the twigs and limbs of trees and nursery stock for the purpose of depositing eggs. When abundant smaller limbs often become so badly scarred and injured that they become

hidebound and cannot grow properly; as a result they are stunted and unthrifty.

In addition, the scars form favorable receptacles for fungous growths and other insects.

The habits and life history have been taken from C. L. Marlatt.

Habits and Life History

The habits and life history of the buffalo tree hopper are as follows: The adult insect chooses as a nidus for its eggs—the twigs, preferably those of two to three years' growth, of various trees, particularly the apple, willow, cottonwood, maple, etc., confines itself in general to the upper surface of the twigs. * * * The eggs are deposited quite as readily in the new growth of old trees, as in young trees, but the damage is much more noticeable in the latter case. * * *

In depositing the eggs the bark is cut by the ovipositor in such a way that the narrow bark intervening between the two incisions is cut entirely loose. This has a very important bearing on the subsequent condition of the wounds made by the insect in oviposition. The object is doubtless to cause a deadening of the wood between the two rows of eggs, to prevent their being crushed and choked out by the subsequent rapid growth of the twig, and it is due to this peculiarity that the injury later assumes so serious a nature. A single incision made by the insect to contain its eggs would heal over and cause little after-damage, but with the combination of two incisions and the killing of the intervening bark, causing it to adhere to the wood, a large scar is produced, which, with each subsequent year's growth, enlarges and ultimately assumes an oval form, the dead bark of the center breaking out. After a few years, limbs which have been thickly worked on by the insect, become very scabby and rough, are easily broken off by the wind and are very liable to attack by wood-boring insects.

The adults first appear about the middle of July and become most numerous during August, or even earlier, and continue this work until they are killed by

the frosts of early winter, sometimes working as late as the end of October. The number of eggs deposited by a single female exceeds 100, and possibly 200. The eggs remain unchanged, or dormant, in the twigs until the following spring, hatching in May or early in June * * *

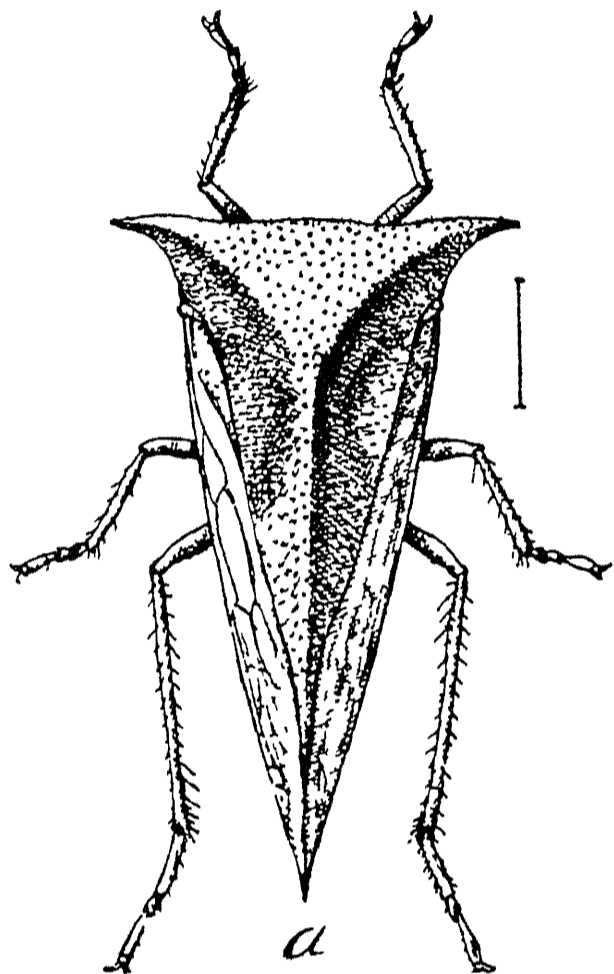

Fig 1. The Buffalo Tree Hopper. Female—enlarged. (After Marlatt.)

The eggs of the buffalo tree hopper are subject to the attacks of at least two minute egg parasites, which often do much to keep the insect in check.

In general characteristics the larvae and nymphs resemble the adults, but are wingless and covered along the center dorsally with numerous forked or barbed projections.

Food Plants

All kinds of succulent plants such as weeds and garden vegetables are fed upon, but in this respect the insect is not a serious pest.

Remedies

The destruction of the insects themselves is hardly practical. By limiting the amount of unnecessary vegetation in and about nurseries and orchards, a great

deal can be done toward keeping down the insect in the larval and pupal stages. Pruning out and burning the infested twigs will also materially decrease their numbers. Clean cultivation will probably do more than all other precautions.

Canker Worm

Notolopus sp.

H. F. WILSON

In the early spring, after the apple leaf buds have opened, we often find numbers of little darkish colored measuring worms, which feed on the leaves. These are called canker worms and are apparently different from our Eastern canker worms. The eggs of this insect are deposited on the trunks and leaves and hatch in the spring. When first hatched the larvae are very small and such feeding as they do is not apparent. As they increase in size the entire leaf, with the exception of the midrib and larger veins, is devoured. About four weeks after hatching the larvae are full fed and then drop to the ground, enter to a depth of a few inches and pupate. They remain here until late fall or early spring, when they change to the adult insect. The eggs are deposited in masses by wingless moths of sluggish appearance that gradually crawl up a small twig, depositing the eggs as they move forward.

The female moth is brownish in color with a slight tinge of gray and measures about three-fourths inch in length. The male moth has not been observed. As the female moth is unable to fly, this species is distributed very slowly, and since the larvae readily succumb to arsenical poisons, there is very little chance for this pest to ever become very serious.

The same remark would apply to the fall canker worms.

Casebearers

Coleophora fletcherella

C. malivorella

The cigar casebearer (*Coleophora fletcherella*) and the pistol casebearer (*C. malivorella*), so named from the shape of their cases, are insects which may do a considerable amount of injury but which may be controlled by spraying

properly. The adults are moths measuring about one-half inch from tip to tip of the wings. The larvae hibernate in cases attached to twigs. In spring they feed on the opening buds and the new foliage till full grown, living all the time in cases which are readily seen projecting from the surface of the bud or leaf. They also attack the flowers and fruit. The case-bearers are distributed from Nova Scotia westward to the Mississippi and southward. They are held in check by a minute parasite.

Treatment

Spray with kerosene emulsion or Paris green early in spring before the leaf buds are opening. Orchards regularly treated for codling moth will not be troubled.

CATERPILLARS. See *Tent Caterpillar*, *Red Humped Caterpillar*.

Cecropia Moth

Samia cecropia

This is the largest caterpillar and moth occurring in the United States. The caterpillar measures, when grown, in the neighborhood of four inches in length and bears along the back blunt tubercles, some red, some yellow, some blue. Some of the larger moths have a wing expanse of seven inches.

The magnificent moth of this insect is so striking in size and colors that most people who have lived in the country or in villages have at some time had their attention arrested by it. The larvae is not less striking, but its green colors are so like those of the leaves that it is not often seen, unless several of them should denude a small tree or two in a doorway. I have known a couple of the ravenous fellows to clear the leaves from a young apple tree pretty completely.

The pupa stage is passed in a large reddish gray cocoon, consisting of tough layers, the outer one separated by a layer of loose silk from an inner oval, completely closed over surrounding the pupa. Not important.

H. GARMAN,
Lexington, Ky.

Climbing Cutworms

(Various species)

Sometimes the expanding buds of apple and other fruit trees are eaten into and

destroyed, yet no destructive agent is in evidence to account for the damage. Some parts of the tree fail to leaf out, or the young leaves on an entire branch suddenly disappear. Some of the blossoms are found to have a hole cut through the side of the calyx and the ovary consumed. Such damage is usually indicative of the work of climbing cutworms which feed at night. Several different species work such injury. Banding the trees as for canker worms, with sticky materials, cotton batting or tin collars is perhaps the most reliable measure. Poisoned bran mash used in conjunction with banding is very effective. Where early spraying is done for the bud worms and casebearers or canker worms, probably no other measure will be needed.

H. A. GOSSARD,
Wooster, Ohio

Codling Moth

Carpocapsa pomonella Linn.

By H. F. WILSON

The codling moth must everywhere be considered an important factor in apple, and to a less extent, in pear growing. It occurs in every important apple growing section of the world, and wherever repressive measures are not employed, annually destroys one-fourth or more of the crop.

Supposed Immune Regions—The above statement is made notwithstanding the repeated appearance of reports of new or little developed fruit regions which, by reason of some especially favorable soil or climatic condition, are supposed to be immune.

Orchardists who are located, or who contemplate locating in such supposed favored regions are cautioned against relying too implicitly upon the continued absence of the codling moth, unless active, intelligent effort, rather than blind reliance upon an unknown factor, be made to prevent its gaining a good foothold. During the past fifteen years we have seen this idea of immunity dispelled in locality after locality in the Pacific Northwest, and when we consider that the codling moth is a serious pest in England, on the continent of Europe

from Mediterranean regions to the northern limits of apple growing in Siberia, in Southern Africa, Australia, New Zealand, Tasmania and China, as well as in the United States and Canada, we are forced to recognize the improbability of perpetually immune regions. Once it gains a foothold the codling moth will thrive wherever the apple can be grown successfully.

We do not wish to be understood as arguing that the codling moth will become equally destructive in all localities, or that its prevalence is independent of climatic conditions. Rather the contrary is true, since the seriousness of its depredations varies with both the locality and the season. Temperature is the great factor which controls the abundance of a species in a given locality; hence, as the female moth deposits eggs freely only when the evening temperature is above 60 degrees Fahrenheit, we should expect to find, as indeed we do find, that the orchards in the coast regions west of the Cascades, and those of the inland plateau sections, are less subject to the ravages of the codling moth than those of the inland valleys. This factor is of but little practical importance, however, and should be given scant consideration in the selection of an orchard site. The probability is that as orchards become more numerous, active repressive measures against the codling moth will become necessary, even in the most favored localities.

Know All Stages—Efficient spraying operations and the proper application of other repressive measures against the codling moth are so intimately linked with its habits, and these habits so varying, within certain limits, with the locality and the season, that every grower should become familiar with it in all of its stages. Unfortunately, however, growers do not seem fully to recognize the importance of such information, or consider it too technical and difficult to obtain. Consequently few actually do know it in any other than the larval or “worm” stage, notwithstanding the fact that a “speaking acquaintance” with all stages is easily acquired.

The codling moth, in common with many other insects, passes through four sharply defined stages during its development, viz.: the egg, the larva or “worm,” the pupa, and the moth or adult. All four stages from the egg to the moth inclusive constitute a generation or a “brood,” and since this cycle from egg to moth is completed twice during the year, the insect is said to pass through two generations yearly, or to be “two brooded.” In some of the warmer apple growing sections of the South three broods are reported. During the winter it exists only in the larval state, but during a greater portion of the summer months it may be found in all four stages.

The Egg—The eggs, which are laid singly, are minute, nearly circular scale-like objects about one-twentieth of an inch in diameter, pearly white in color and somewhat translucent. They may well be likened to minute trout scales glued to the surface of a leaf or fruit. The surface of the egg, however, is finely wrinkled and so reflects the light that it appears as a minute glistening speck, if the fruit or leaf to which it is attached is held at the correct angle before the eye. In two to four days after oviposition the developing larva becomes distinctly visible as a black spot near the center of this circle and the outline of the whole body is discernible for a day or two before the egg hatches. The eggs hatch in from seven to ten days.

The Larva—When first hatched the young larva is scarcely one-sixteenth of an inch long. The head is large, black and shining; the body is slender, translucent white in color and marked with distinct black spots, each of which has a minute bristle. Owing to their minute size and to the fact that they usually enter the fruit very soon after hatching, these young larvae are rarely seen. As the larva develops it molts five times; the color of the head and the thoracic and anal shields turn black to brown, and the body acquires a pinkish tinge. The full-grown larva is about three-fourths of an inch long and one-twelfth of an inch

in diameter. The duration of the larval stage is from sixteen to twenty-four days.

The Pupa—Shortly after becoming full grown the larva leaves the apple and seeks some protected spot in which to hide while passing through its transformations from larva to pupa, then to moth. Having found a suitable place, it hollows out a little oval cavity with its jaws and proceeds to envelop itself in a thin tough cocoon of silken threads intermingled with particles of the excavated material. When completed, the cocoon is usually oval in form and about three-fourths of an inch long. When the pupal stage is reached the insect remains in that stage for about three weeks, and then emerges as the adult or moth.

The Moth or Adult—The moths are really beautiful little creatures. The body

is about three-eighths of an inch long and is of a modest greyish brown color. The fore wings when fully expanded measure about three-fourths of an inch from tip to tip and are of approximately the same color as the body but relieved by inconspicuous, transverse wavy lines or lighter scales. The hind wings which are entirely covered when the insect is at rest are nearly slate colored and are clothed with long hairs. The most characteristic marking is a large golden brown spot at the posterior outer angle of each front wing. No other insect is known which has this marking and no insect need be mistaken for the codling moth. The males are further distinguished by a narrow pencil of black hairs on the hind wings and an elongated black spot on the upper surface of each front wing.

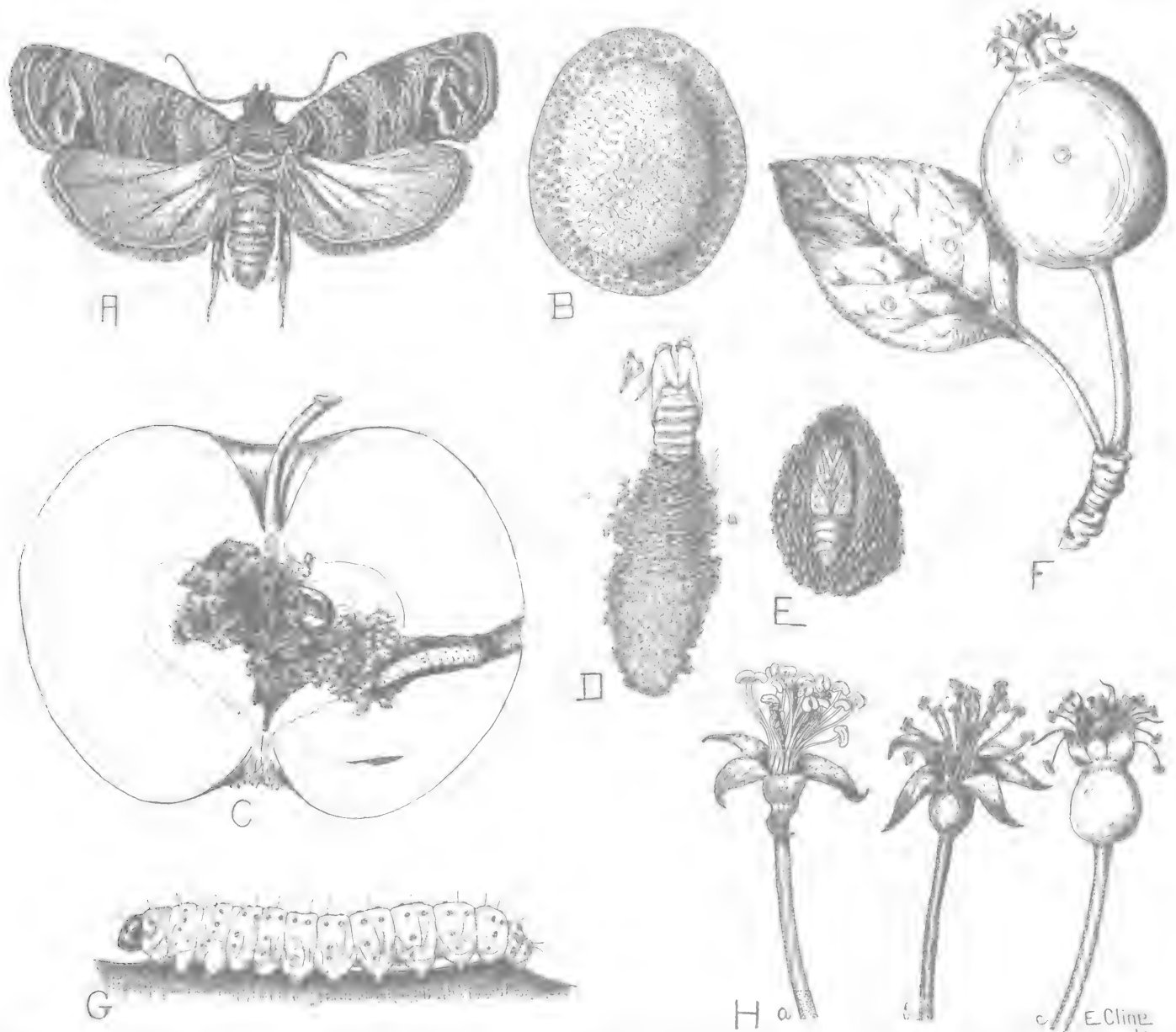

Fig. 1. Codling moth. A, adult moth with wings expanded; B, egg much enlarged; C, half of worm-eaten apple; D, cocoon with empty pupa shell protruding; E, cocoon with pupa enclosed; F, leaf and apple showing eggs of a codling moth; G, caterpillar or "apple worm" enlarged; H, a, young apple just after petals fall; b, cup beginning to close; c, too late to spray. (Montana Experiment Station.)

Owing to their coloring, which resembles closely that of the bark upon which they often rest, and their habit of remaining quiet during the daytime, these moths can very rarely be detected in the orchard. Occasionally one may be seen flitting about the trees at twilight, and very rarely we have observed them resting



Fig. 2. Adult Resting on Apple.

quietly upon the bark and leaves and even on the ground. When disturbed they start away with a swift zig-zag motion very hard to follow. For the purpose of depositing eggs they normally fly only during the warm nights, and are presumably most active during the twilight period.

Recommendations for Northwest

Conditions which are found in the Eastern states have but little bearing upon somewhat dissimilar conditions found in this section. Early spraying alone will not save the fruit, and it is not only practicable but necessary to fight the second brood. So far as the codling moth is concerned, early applications, after the calyx lobes close are of very little value in Western Oregon and Washington. In the orchard sections of those regions the petals fall from the first week in May to several weeks later in sections along the coast.

The first larvae enter the fruit at Corvallis, Oregon, rarely before June 25, so that a period of about six or seven weeks exists between the time of the calyx spray

and the time when the larvae enter the fruit. This is in a great measure due probably to the fact that the eggs of the codling moth are not deposited until the evening temperatures reach 60 degrees Fahrenheit, or above.

At Roseburg, Oregon, the records of the U. S. Weather Bureau for the past ten years were examined and notes made as follows: After May 20, at dusk of each day the temperature is about 60 degrees Fahrenheit, or above. Beginning with June 1 the evening temperature, up to 12 o'clock, does not fall below 65 degrees Fahrenheit. At Roseburg, June 8, eggs, hatched and unhatched, were found with an occasional larva entering the fruit.

At Medford, Oregon, the larvae begin to work in the fruit about the same time.

Recommendations for Spraying in Northwest

Make at least three applications and in renovating old orchards a fourth will not do any harm.

1. In all sections spray immediately after the petals fall.

2. In all sections of Western Oregon and Washington it is not necessary to spray two weeks after the first application. Make the second application approximately six weeks after the calyx spray, and the third about five weeks after the second. Where a fourth application is deemed necessary, spray about three weeks after the third.

3. In sections of the Northwest, east of the Cascade mountains, spray from two to three weeks after the first application, depending upon the weather conditions. Make a third application five weeks after the second and a fourth two weeks later than the third.

Poisons To Be Used

Paris green, London purple, arsenate of lime, and arsenate of lead, are the principal arsenites which have been used for spraying. At present the last-named is practically the only one used. The principal brands upon the market at present are Bean's Ortho 13, Better Spray, Grasselli's Star, Lyons', Swift's, and Sherwin-Williams. These fall readily into two classes, viz.: the neutral ortho-arsenates

and the acid arsenates. In those of the first group the ratio of lead oxide to arsenic oxide is approximately 3 to 1. In those of the second group the ratio is as 2 to 1. The neutral or ortho-arsenates are made by combining lead acetate and sodium arsenate; the acid arsenates by using lead nitrate in place of lead acetates. The insecticidal value of the various brands depends upon the actual amount of lead arsenate which is present.

Concerning the relative value of neutral and acid arsenates no reliable experiments have demonstrated the superiority of either. It is commonly believed that the acid arsenates are more likely to burn foliage and we have received reports of injury from the use of Swift's which would seem to support the inference. Manufacturers advise using 3 pounds arsenate of lead to 50 gallons of water. We usually recommend 2 pounds, and Melander, of Washington, recommends to drench the trees with a weak solution of 1 pound to 50 gallons. Recently there has been placed upon the market a product known as zinc arsenite, which is said to be cheaper and better than arsenate of lead. Several growers have reported injury from this spray and it does not appear favorable. We have experimented with this spray during the past season and found it quite satisfactory.

Cottony Maple Scale

Pulvinaria vitis Linn.

Pulvinaria innumerabilis Rathv.

General Appearance

This species can be easily recognized in early summer by the large white cottony egg-sacs which are posterior to the brown female bodies.

Life History

The eggs are very small, oval, and white to yellow in color. They are deposited in the large, loose, cottony sacs, which are secreted by the females. The young first settle on the leaves and later move to the limbs. The males appear late in the fall to mate and die. In the spring the females increase very rapidly and after egg-laying shrivel and die. There is but one generation a year.

Distribution

Maine to California.

Food Plants

Maple, pear, apple, plum, peach, grape, sumach, linden, sycamore, locust, beech, elm, oak, orange, box-elder, spindle-tree, mulberry, alder, hawthorn, lilac, blackberry, willow.

Control

Kerosene and carbolic acid emulsions, or resin wash, applied when the young are hatching will aid in reducing the coming broods.

Natural Enemies

There are many natural enemies, including *Rhizobius ventralis*, *Coccophagus lecanii* and *Encyrtus flavus*, which prey upon this coccid.

E. O. ESSIG

Curculio

Anthonomus quadrigibbus Say

Conotrachelus nenuphar Herbst.

Two species attack the apple. The plum curculio and the apple curculio. *Conotrachelus nenuphar*, Herbst. and *Anthonomus quadrigibbus*, Say. Doubtless the curculio does more injury to the apple crop in some of the Central states than any other insect except the codling moth. It is a snout beetle about one-fourth inch long and of a dark grayish color. The snout is long and slender and may be folded under the body. The beetle winters under rubbish or in the soil and in early spring begins feeding on the opening leaves. After fruit sets it may gnaw little holes in the fruit, but it does most damage by laying its eggs in the fruit, cutting a crescent flap at the place where the egg is laid.

This insect infests the plum, cherry, and peach, as well as the apple. Comparatively few of its larvae develop in the apple but they develop freely in the plum and sweet cherry. They develop less readily in the sour cherry and peach. Since damage to peach, cherry and plum often results from the fruit rot fungus entering through the wounds made by the curculio. Orchards well cared for

and sprayed for codling moth and other pests will not be unduly troubled.

S. A. BEACH,
Ames, Ia.

Reference.—Illinois Experiment Station Bulletin No. 98.

CURTIS SCALE. See *European Fruit Scale*, this section.

Ermine Moth
Yponomentidae

Small moths with snowy white, black dotted front wings. The hind wings are gray or leaden in color.

Imported to New York from Europe upon nursery stock.

As the larvae feed upon the foliage they are easily controlled by arsenical sprays.

They attack apple and cherry as well as a variety of other plants.

Geneva Technical Bulletin No. 24.

EUROPEAN FRUIT LECANIUM. See *Prune*.

European Fruit Scale or Curtis Scale
Aspidiotus Ostreaeformis

The female is circular or broadly oval in outline, dark ashy gray in color with paler margin; sometimes the scale is nearly white. The exuvia is central or nearly so, dark brown, usually naked and glossy. Diameter $\frac{1}{8}$ of an inch.

Life History

The winter is passed by partly grown individuals which become mature early in the summer. The insect gives birth to living young which begin to appear soon after the maturity of the female. In this State they are apparently but one brooded.

This scale has been recorded from a number of different plants, among them, the apple, pear, plum, peach, cherry, birch, poplar, horse chestnut, basswood, alder, haw, maple, aspen, oak, etc. It has been reported in this country from Maine, New York, New Jersey, Michigan, Ohio, Iowa, Idaho, California and several other states. In Maine it is most frequently found on large trees in old and neglected orchards, though we have records also of its occurrence on currant bushes. Specimens the past season



Fig. 1. The European Fruit Scale on Branch of Apricot. (Essig. Bulletin 2, Vent. Co. Hort. Com., Cal.)

were received from Brunswick, Millvale, Buckfield and W. Auburn.

Remedies

Spraying with lime-sulphur late in the winter or early spring before the appearance of the leaves will control it.

O. A. JOHANSEN,
Orono, Me.

Eye Spotted Bud Moth
Tmetocera ocellana Schlieff

H. F. WILSON

The larvae of this moth resemble those of the Peach and Prune Twig Miner quite closely, and they are often mistaken one for the other, but the latter work only on the stone fruits, while the former work on practically all of the orchard trees. By careful examination they can readily be distinguished by the anal shield, which on the above insect is shining black like the head and thoracic

shield, while that of the twig miner is the same as the rest of the body. When fully grown, the larvae are one-half inch long and of a dirty gray color. They are not yet full grown with the opening of the buds in spring and will feed upon the blossoms during the entire blossoming period. They may mat the blossoms and leaves of a cluster together with their silken threads within which they feed, making it difficult to reach them with spray.

Life History

The larvae, like those of the twig miner, winter on the twigs and branches in an immature condition, but while the twig miner excavates a cavity in the bark, the larvae of the bud moth form minute inconspicuous cocoons on the bark. This is a peculiar habit of a few larvae that form cocoons before reaching maturity.

As the buds start in spring the larvae leave their winter quarters and begin feeding upon the outcoming leaves and blossoms. They mature in early May, pupate, and in from 10 to 14 days appear as adults. The moths deposit eggs in late May and early June, probably upon the leaves (although this has not been determined). The young larvae feed on the under surface of the leaves and skeletonize them, especially in the vicinity of the midrib. So far as known, there is but one generation, although from the shortness of the life cycle, it is apparent that moths from the first brood might produce a second generation that would mature in time to deposit eggs for the spring forms.

Remedies

There are three methods of control. The first is to spray the trees before the buds start in spring in order to destroy the overwintering larvae. One application of crude oil emulsion or kerosene emulsion, applied just before the buds start, would be the most effective means for this.

The second method is to spray with arsenicals when the larvae are feeding upon the foliage and blossoms, but they

are sometimes hard to reach, especially when they have matted the blossoms together. The pome fruits that are well sprayed for the codling moth will not be bothered with the bud moth.

Third. Recent experiments tend to show that the best time to spray for this insect is in the fall at a time when the larvae are working on the under side of the leaves. This spray applied about September 1, will also help to catch a great many codling moth larvae.

Fall Web Worm

Hyphantria cunea Dru

The moth producing this caterpillar is white and sometimes has a few black spots on the wings. The larvae hatching from masses of eggs laid on different parts of the trees spin their webs which extend over quite an area. These webs may be noticed in the Mesilla valley by the middle of July on a number of trees, but more particularly on the cottonwood and poplar. The caterpillars will first eat all the leaves within the web, then those nearest by, often defoliating the entire tree. The worm is noticeably set with

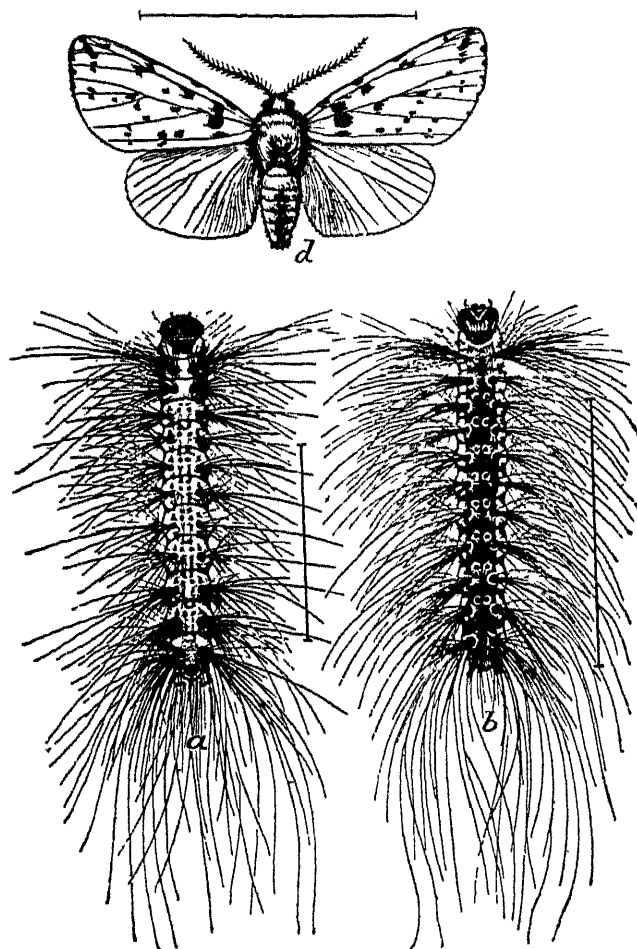

Fig. 1. Fall Web Worm. *a, b*, caterpillars; *d*, moth. (Howard, yearbook, 1895, B. of Ent. U. S. D. A.)

tufts of bristle-like projections. Two broods are reported, the last one seems to be the worst. This insect is sometimes confused with the tent caterpillar which appears in the spring and builds its webs in the forks of the limbs.

Remedies

The clusters of eggs on the limbs should be destroyed if possible when the leaves are off. The webs or tents may be cut out and destroyed or they may be burned with a torch. If this cannot be done spray with standard solutions of some of the arsenical mixtures.

FABIAN GARCIA

Fruit Tree Bark Beetle *Scolytus rugulosus* Ratz

General Characteristics and Method of Work

Orchard trees are subject to the attack of a small boring insect, the fruit tree bark beetle (*Scolytus rugulosus* Ratz), its presence being manifested by what are called "worm holes," minute round openings in the outer bark scarcely a sixteenth of an inch in diameter, accompanied by wilting of the leaves and shriveling of the bark, and, in the case of stone-fruit trees, by more or less copious exudations of gum. The first appearing holes are made by the parent beetles in entering the bark to deposit their eggs, but later, if no effort is made to check the insect's work, the bark will be found thickly "peppered" with holes as though by fine bird shot. These are the exit holes of beetles that have in their larval stage mined and developed under the bark.

Distribution

Since first observed in this country in 1877 the species has spread pretty generally from New York westward to the Mississippi states.

Life History

As early as the middle of March, first of April or later in May, according to locality and season, the parent beetles make their first appearance and may be seen crawling about orchard trees and beginning to burrow through the bark. After penetrating to the sapwood, the female

constructs, partly within the bark and partly in the wood next to it, a vertical gallery or brood chamber, and along the sides of this at very short intervals gnaws little pockets in which she deposits her eggs. The minute, whitish, grub-like larvae hatching from these eggs excavate little side galleries, which start out at right angles to the brood chamber but soon diverge and widen with the increase in size of the growing larvae. Much more frequently this insect lives in such numbers, with its galleries so closely packed together under the bark of a tree, that it is with difficulty that individual galleries can be distinguished.

The complete transformation from egg to adult occupies from four to six weeks. There are two, and possibly three, broods.

Remedies

The beetles are held in check by a number of parasites. The "cutting out" method in use against other borers is of little avail in this case.

Where clean culture is practised and trees are regularly sprayed for codling moth and scale these insects will be in large measure repelled. The beetles may be killed in specially infested areas by light applications of kerosene oil, after which these areas should be cut away.

From Div. Ento. Circular 29, Revised.

Fruit Tree Leaf Roller *Archips argyrospila* Walk

Introduction

Until quite recently the fruit tree leaf roller (*Archips argyrospila* Walk) has been looked upon as an insect of only minor importance to cultivated crops. During the past few years, however, it has become unusually abundant and has caused considerable loss to fruit growers in certain sections, notably in Colorado and New Mexico and in New York state.

The damage incurred by the leaf roller has varied from 25 to 90 per cent of the entire fruit crop, depending on the measures of control adopted, the abundance of the "worms," and the kind or variety of fruit attacked. In unsprayed orchards

the writer has seen the entire fruit crop ruined by the larvae, and the trees completely defoliated so that not a green leaf could be noticed. When trees are so defoliated it is hardly possible for them to produce fruit buds for the following season.

Distribution

The fruit tree leaf roller is generally distributed throughout the United States. Stedman, in Bulletin No. 71 of the Missouri Experiment Station, page 7, states that "this insect is found in damaging numbers practically all over the United States from Maine to the Gulf and westward to the Pacific coast and up as far as Oregon."

Food Plants

The insect is a very general feeder and consequently has been reported on a large number of plants. It appears at times in injurious numbers on apple, pear, plum, cherry, apricot, quince, peach, rose, currant, raspberry and gooseberry.

Character of Injury

As the manner in which the larvae attack the various host plants differs to a certain degree, it seems advisable to give a rather full discussion of the more important injuries, especially those occurring on fruit trees.

In the spring, just as the buds are bursting, the larvae begin to gnaw their way out of the eggshells and hard protective covering of the egg masses. The young caterpillars at once migrate to the developing buds and begin feeding on the unfolding leaves. At first they eat small inconspicuous holes in the unfolded leaves, and at this time the average orchardist is not aware of their presence. After feeding in this manner for a few days the larvae become quite conspicuous as they begin to spin fine silken threads from leaf to leaf. Eventually they fold or roll up a single leaf or a cluster of leaves and here they feed for the greater part of the time, though occasionally straying out of their concealment to feed in the open. Before the blossoms are fully out, or even before the cluster buds have separated, the "worms"

can be observed webbing them together and feeding voraciously. Very often serious injury results before the trees come into blossom. Later in the season the webs produced by the larvae are often quite conspicuous.

As soon as the young fruit has set the larvae cease feeding on the foliage to a large extent, and now fasten one or more leaves to the fruit and within this protection feed greedily, at first eating the skin only, but shortly consuming the pulp and the seeds or stone, depending on the kind of fruit attacked. Sometimes young apples are completely devoured except for the stem and a portion of the calyx end. Cases have been noticed where the larvae have completely gnawed through the stems, thus causing the fruit to fall to the ground or remain suspended within the feeding nest. Damage done to apples as well as other fruits is usually so severe that the fruit can not outgrow the injury, thus causing a large percentage of unmerchantable or second-class fruit at picking time. Much fruit is also caused to fall prematurely on account of the serious injury inflicted on it when young.

Life Habits

The Egg

The female moth deposits her eggs in compact oval clusters of about twenty-five to more than one hundred, anywhere upon the bark of the fruit trees that serve as its food supply. As soon as the egg mass has been deposited, the female moth smears the eggs over with an impervious material which is thrown out from the extremity of the abdomen, and which protects the eggs from the inclemencies of the weather and the attacks of predaceous insects for nearly ten months, or until the buds begin to open the following year. So there is but one brood of the worms each summer.

The eggs are stuck so tightly to the bark when they are deposited that they often remain for several years. The old egg patches are readily recognized by the numerous small punctures from which the larvae or worms escaped.

The Larvae or Worms

The larvae do not all hatch at once, those in the warmer situations being the first to emerge, and those coming from a single egg patch usually vary several days in their date of emergence.

The date of hatching is by no means constant, but is determined by the earliness or lateness of the season, exactly as is the time for the opening of the buds. The earliest of the larvae emerge with the first bursting of the buds of the apple trees, and when the blossom buds of the apple begin to show their pink color the larvae of the leaf roller have mostly hatched. The active hatching season is usually distributed over about one week to ten days, the time varying with the temperature. If the days and nights are cool, the period lasts longer than if hatching takes place at a time when the days and nights are warm.

At first the larvae are very small, hardly one-sixteenth of an inch in length, and dull greenish-yellow in color, with black heads. As they feed and grow, they become deeper green in color, and the black head and first segment of the body above become quite conspicuous.

On hatching, the little larva goes at once in search of food, and may eat into an unopened bud or find its way into one of the folds of the tender unfolding leaves, which it soon ties together with delicate silken threads of its own manufacture. Thirty days of feeding are sufficient to mature the larva, which then ceases to feed, and in a few days more changes to the third, or chrysalis (pupal), stage, usually among the curled leaves which it has tied together with the silk threads above mentioned.

The Moth

The moths measure from three-eighths to four-eighths of an inch in length with the wings closed; the expanse of the full-spread wings usually varies between eleven-sixteenths and one inch, the prevailing color is a rusty brown, varying in typical specimens from rather light to quite dark, and there is always present a large pale-yellow to almost

white diagonal patch on the front margin of the wing a little beyond the middle.

Natural Enemies

The fruit tree leaf roller has numerous bird and insect foes which tend to hold it in check. The various bird enemies are the blue bird, robin, catbird, red-winged blackbird, oriole, kingbird, phoebe and English sparrow.

The fruit tree leaf roller in the larval stage has been found difficult of control because of the manner in which the larvae feed on the foliage and fruit, and also on account of the fact that they are very resistant to poison sprays. Applications of arsenicals alone and in combination with 40 per cent nicotine solution have greatly reduced the amount of injury to the fruit and foliage, but these sprays have not been so effective as is desirable.

A series of experiments for the destruction of the egg masses, conducted during the dormant season, have shown the value of mineral oils. Kerosene emulsion, crude-petroleum emulsion, and miscible oils have been tested. The last mentioned, when used at the strength commonly employed against the San Jose scale—that is, 1 gallon to 15 gallons of water—will prevent most of the eggs from hatching. From 93.23 to 96.21 per cent of the egg masses were destroyed by this material on the experimental plats. Good results also were obtained by the use of kerosene and crude-petroleum emulsions, although these substances were, on the whole, not quite equal to the miscible oils. The ease with which sprays may be prepared from these last commend' them to many orchardists although the home made emulsions are cheaper. In preparing a kerosene or crude-petroleum emulsion care is necessary to insure a thorough and stable emulsion.

It should be stated that injury to trees treated with oils sometimes follows, although no such injury was noted in connection with the present experiments. No more spray should be used than is necessary properly to treat the tree, and the

puddling of oil around the crown should be guarded against.

Lime-sulphur solutions proved to be a decided failure as a destroyer of the egg masses. Strengths ranging from 1 gallon of lime-sulphur to 7 gallons of water to 1 gallon of lime-sulphur to 10 gallons of water were sprayed on apple trees and no benefit was derived from their use.

Recommendations for Control

Experimental work has shown that the best method for controlling the fruit tree leaf roller is by a very thorough application of a miscible oil at the rate of 1 gallon to 15 gallons of water during the dormant season. It must be understood that by thoroughness of application is meant the use of enough material to cover all parts of the tree, from the tip of the highest or smallest branch to the very base of the trunk. In order to do thorough work the trees must necessarily be sprayed from all directions. It is very often the case that the top branches or those around the inside are missed by the man operating the rod. It must be remembered that only those egg masses actually hit or covered with the material will fail to hatch and those missed will surely hatch out "worms" in the spring to feed upon the trees. Orchardists should realize that thorough spraying with the right material and at the proper time pays well, but careless, haphazard work gives disappointing returns.

All plants upon which eggs have been laid should be sprayed. Besides fruit trees, egg masses may be found on various shade trees, shrubs, and currant, gooseberry, raspberry, and rose bushes, etc. Eggs will also be found on buildings, spray outfits, wagons, fences, etc., and it is recommended that these egg masses be crushed so far as is practicable.

The best time to spray is just before the buds burst in the spring. Late spring is preferable to early spring, as weather conditions are usually more favorable. There is also less likelihood of injury to the trees by the oil after the sap has begun to flow with considerable pressure.

Spraying should not be done during threatening weather. Orchardists should bear in mind that the strength of miscible oil recommended is for a dormant spray and should never be applied to trees in foliage. Spraying should be completed in the spring before the buds have advanced so far as to have the green tips exposed. If the above precautions are carefully followed in applying the miscible oil, danger of injury to trees will be reduced to the minimum.

There are a number of good commercial brands of miscible oil on the market. These miscible or soluble oils are so made that they mix readily with water. Nozzles with medium-sized holes or apertures are recommended.

Miscible oils at the strength recommended for the destruction of the eggs of the fruit tree leaf roller are valuable in controlling scale insects such as the San Jose scale, Howard scale, etc. Orchards sprayed with the oil for the leaf rollers will not require the usual application of lime-sulphur for the San Jose or Howard scales.

In conjunction with the oil treatment in badly infested districts it is recommended that a very thorough application of arsenate of lead, at the rate of 3 pounds to 50 gallons of water, be applied when the larvae are emerging from the eggs. The larvae will be found to be hatching just as the cluster buds on early-blooming varieties of apple are beginning to separate. The necessity for making this application will depend largely upon the thoroughness with which the miscible oil was applied.

From Div. Ents. Circular 29, Reissued

References

- Bureau Entomology, Bulletin 116.
- Colorado Board of Horticulture, 1912 Report.
- Cornell Bulletin 311.

Fruit Tree Leaf *Syneta*

Syneta albida Lec.

H. F. WILSON

Although this insect has been doing quite a little damage for some time, there

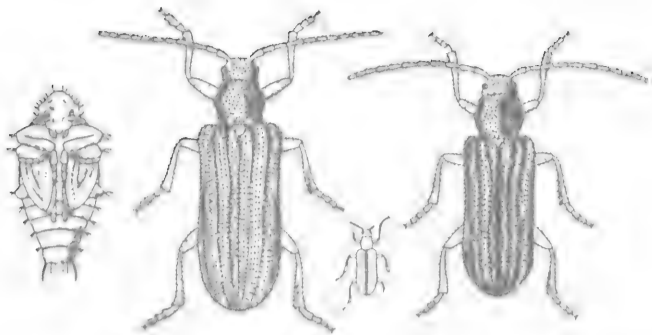

Fig. 1. The Fruit Tree Leaf Syneta: Pupa and adult. (Original)

are practically no published notes on its habits and life history.

The adults suddenly begin to appear in the spring at the time when the apple blossoms are opening and are very abundant for a few weeks, when they suddenly begin to disappear and in a few days can only be found in scattering numbers.

We have been unable to locate the eggs but suppose they are deposited in the ground upon roots of some kind. During 1912 larvae dug from the ground beneath apple trees formed into pupae and later changed to the adult stage. At that time it was impossible to tell whether the larvae were feeding upon the roots of apple or upon the roots of some grass or weed as the roots of all three were more or less intermingled. A number of larvae were found at a depth of fourteen inches below the surface of the ground.

The only injury which we are acquainted with is that done by the adults and at times this is quite serious. When the blossoms are opening in the spring, the adults can be found feeding on the petals and one would suppose that the fruit would suffer as a result, but apparently the principal parts of the flower are left uninjured. Later in the season the leaves of apples and prunes are the principal parts eaten, and oftentimes trees will have nearly every leaf with from one to several holes eaten out. The worst and most serious injury is done to young grafts, especially where whole orchards are being grafted over. These grafts where the leaves are continually eaten away for several years are killed, and consequently the tree itself is lost.

Remedies

Such remedies as have been tried are more or less unsatisfactory. Arsenate of

lead in ordinary strengths fails to destroy the beetles, and stronger strengths seem to be only partially successful. With young grafts the beetles can be kept away by the use of cheesecloth sacks placed over the grafts.

Greedy Scale

Aspidiotus camelliae Sign

Aspidiotus rapax Comst.

General Appearance

This scale greatly resembles the San Jose scale, but is somewhat lighter in color, larger, much more convex, being noticeably high and with exuviae near one side. The shell is thin, showing the yellow body beneath.



Fig. 1. Greedy Scale (*Aspidiotus camelliae* Sign.) around calyx of apple. (Cal. Hort. Com.)

Distribution

One of the commonest scale insects and found in wild as well as cultivated areas throughout the state.

Food Plants

This species attacks a very large list of plants, though it has never yet become a serious pest to any horticultural or agricultural product. Among the food plants reported in California are quince, eucalyptus, fuchsia, English ivy, mountain holly, walnut, myrtle, olive, cottonwood, almond, cherry, pomegranate, pear, apple, rose, willow, California bay or pepperwood and grape.

Natural Enemies

An undetermined internal parasite has been bred from this species.

E. O. ESSIG

Green Apple Aphis

Aphis pomi or *Aphis mali*

These lice lay their shiny black eggs in October and November in crevices of the bark and in scales of the buds of the apple trees. After the first brood hatches in the spring about the time of the unfolding of the first buds and until late in the autumn they may be found at all times on the apple trees. Their presence in the spring may be detected by the curling of the tender leaves on the under side of which the aphids make their home.

These lice, like others of the family, eat more than they can assimilate and the excess exudes from the "honey tubes" near the posterior end or from the anal opening. "This liquid is highly prized

by the ants, which are nearly always to be found running over and around the aphis colonies. It is a great mistake to suppose that ants eat the aphis or injure them in any way, on the other hand ants often protect and aid some species of lice in return for the sweet liquid, called honey dew, of which they are so fond.

*"The honey dew is directly responsible for the black, sooty fungus growth which nearly always follows the appearance of the green leaf aphis. The fungus thrives on this honey dew, and soon clogs the breathing pores of the leaves, resulting in their turning brown, withering and dying. In this manner it may prove quite injurious to leaves not actually infested by aphids because such quantities of honey dew drops from aphis colonies to the leaves beneath."

The first two or three generations of

* R. I. Smith, North Carolina Experiment Station, Bulletin 206.

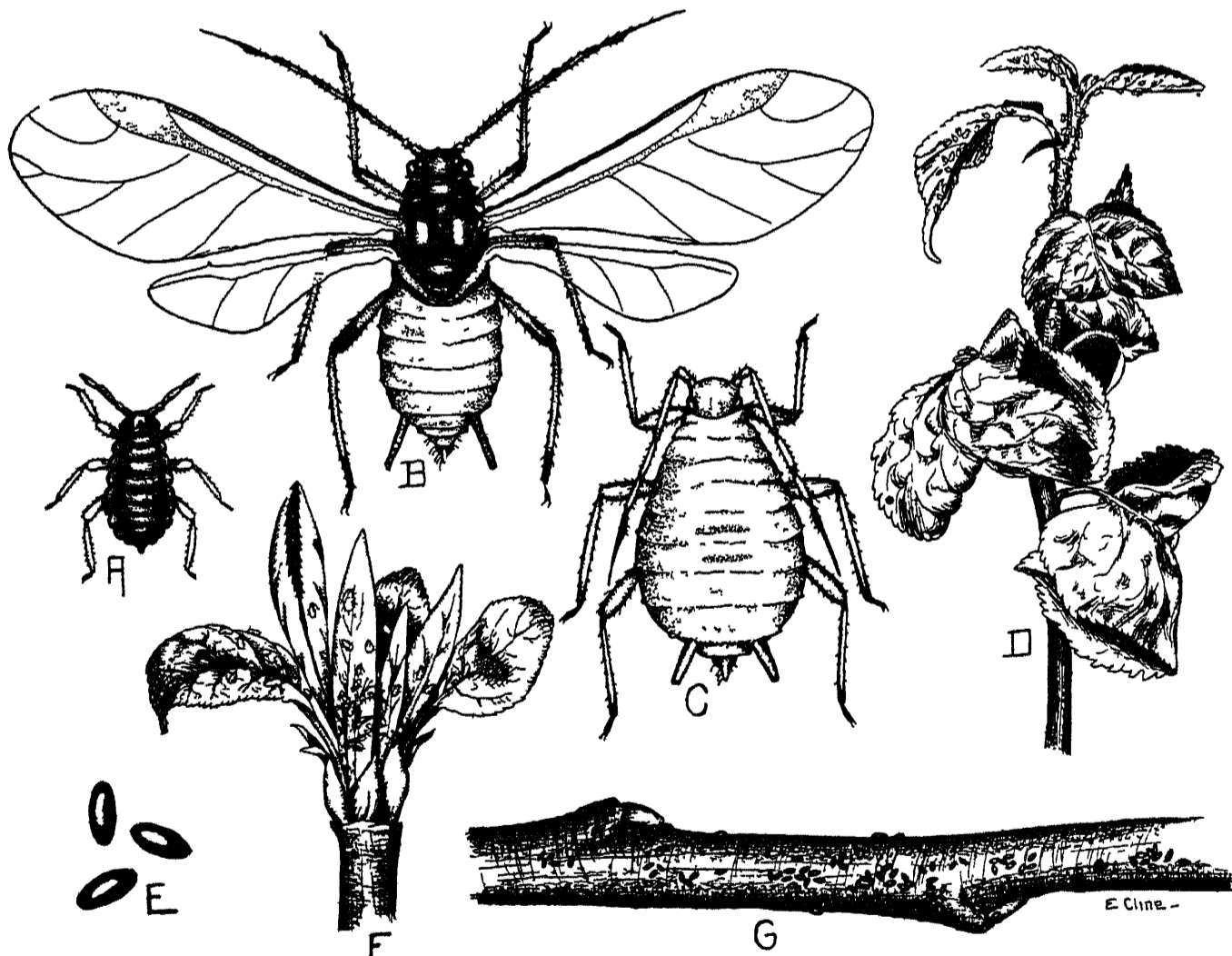

Fig. 2. Apple Aphis. A, stem mother just hatched from egg; B, winged female such as migrate from tree to tree during summer; C, wingless female of summer form; D, leaves curled by this aphis; E, eggs magnified; F, buds just opening, showing newly hatched eggs; G, twig showing eggs as they appear in the winter time. (Montana Experiment Station)

this aphid give birth to both winged and wingless forms. After the third brood no winged generations appear. All broods after the first are viviparous females, that is, they give birth to living young. Each "stem mother" gives birth to about fifty at the rate of eight to ten per day, each new generation coming to maturity in about ten days or less. All this time no males have been present in the colony but some appear in the last brood in the fall and with this generation eggs are produced which preserve the species over winter.

Control

For remedies see end of general article on aphids.—Ed.

Green Fruit Worm or Green Apple Worm *Xylena* sp.

The green fruit worm is a yellowish green, naked caterpillar, which eats into the sides of the small green apple, the results of which are shown in the cut. It also eats the leaves. When fully grown it is nearly an inch and a half long. Numerous reports from the Bitter Root valley indicate that considerable damage is done by them there. The caterpillars often make only small openings in the skin of the young apples, but instead of healing smoothly these wounds form a rusty or corky area, which has often been mistaken for the true apple scab by persons who have not seen the latter. Similar injury is sometimes done to the pear.

Other Food Plants

Besides the apple and the pear a considerable number of other plants are fed upon by this insect, including peach, plum, quince, currant, oak, wild cherry, box elder and rose. It is probable that other plants, at present unknown, are included in the diet of these caterpillars. With this list of food plants, it is apparent that we cannot hope to ever approach eradication and that our efforts should be directed merely toward reducing the damage in the orchards.

Distribution

The exact identity of the parent of these fruit worms is not known, but it is

probable that the species concerned is of wide distribution in the United States.

Life History

This species belongs to the same family of moths as the ordinary cut worms and the parent insect is a dull, night-flying moth, which would not attract attention if it were to be seen by the fruit grower. The details of its life history are not well known. It is probable the eggs are laid soon after the leaf buds open and the young worms hatching a few days later feed first on the leaves and later on the fruits. They continue their feeding through the early part of the season

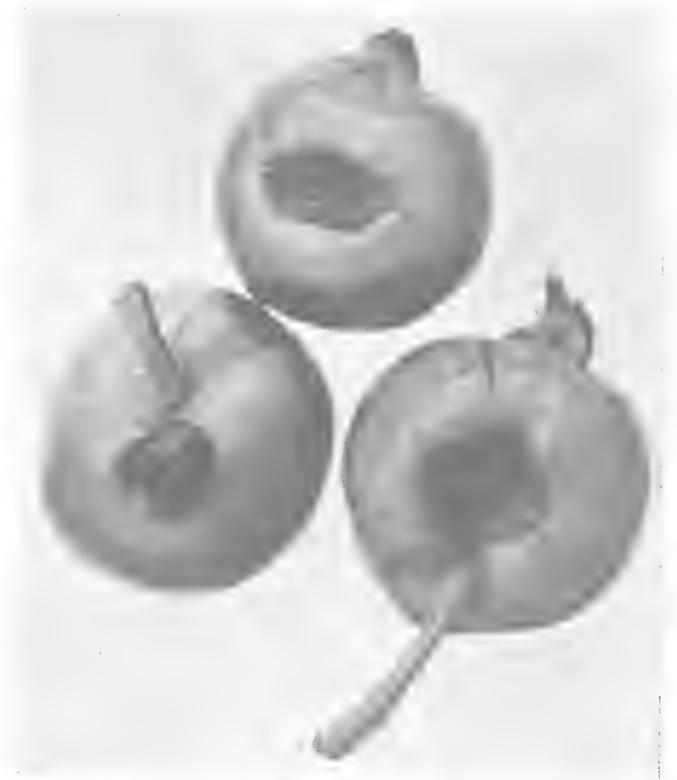

Fig. 1. After Effects of Green Fruit Worm.
(Original)

and reach full size about the time the apples are an inch in diameter, when they go into the soil and pupate. In the late summer and early fall the moths issue from the pupae and pass the winter under any favorable shelter. In the spring they resume activity and deposit their eggs on the trees as above indicated.

Control

Clearly, spraying is the only method by which we may expect to be able to destroy these worms and, from the fact that they feed extensively upon the foliage, it would appear to be easy to get satisfactory results.



Fig. 1. Gypsy Moth. 1, caterpillar feeding; 2, caterpillars climbing a tree; 3, female moths and pupa; 4, male moth; 5, female laying eggs. (Mass. Dept. Agri.)

Professor Slingerland, of Cornell University, has pointed out that in the experience of some of his correspondents, it is very difficult to kill this green fruit worm after the apples are large enough to furnish food. It is probable that an early spraying would be effective and we recommend that four pounds of arsenate lead be added to every 50 gallons of lime-sulphur or the tobacco extract applied just before the fruit buds open, or in water at the same time or a little earlier if there is no other pest requiring treatment.

R. A. COOLEY,
Montana Circular No 17.

Gypsy Moth
Porthetria dispar Linn.

By H. F. WILSON

Like many other of our most serious pests this insect was imported from Europe and has been the cause of considerable trouble in this country. We do not as yet have this pest in the Northwest, but everyone is warned to be on the lookout for it.

The eggs are deposited in masses measuring three-fourths by one-half inches and containing approximately 500 eggs. At first these egg masses are yellowish in appearance but during the winter, exposure to the weather causes them to become a dingy white. The individual eggs are about the size of a pinhead, and when first deposited are salmon colored, turning dark in the course of a few weeks.

These eggs hatch in the spring and each egg mass produces a mass of young dark caterpillars, which become full grown by midsummer. The caterpillars are decidedly hairy and as they grow older assume a varied coloring along the back. Starting from the head, which appears mostly yellow, may be found a double row of five pairs of blue spots; these become very distinct on the larvae as they reach maturity and as the larvae are entirely distinct from any others which we have in the Northwest, they should be easily recognized if one meets with them.

When full grown, which is in midsummer, the caterpillar spins a few strands of silk for support and changes to a chry-

salis, which is the pupal stage. In this stage they are dark reddish in color and thinly sprinkled with light reddish hairs. They remain in this stage for about two weeks and then change to the adult insect. The female moth is white with numerous black markings, is quite robust and moves about very sluggishly.

The male is brownish yellow with sometimes a greenish tinge. They fly about during the day and after mating with the females live but a very short time. The males measure about one and one-half inches from tip to tip of wing. The females measure about two inches but do not fly and therefore do not spread as rapidly as they might. After copulation takes place the females deposit their eggs and die.

This pest is probably mostly distributed by egg masses on nursery stock, but as the larvae have a habit of spinning webs and dropping from trees they are oftentimes carried on automobiles and other vehicles for long distances.

The gypsy moth caterpillar will attack all fruit, shade and woodland trees. Apple trees seem to be preferred above all others.

There are many natural enemies of the gypsy moth and in Europe these are sufficient to keep it under control.

In the United States it will be necessary to wage combat until such natural enemies as are being imported can increase to numbers corresponding to those of the gypsy moth.

Remedies

The most effective time to catch this insect is in the egg mass. These wherever accessible, can be killed by soaking them in creosote. When the caterpillars are quite small they can be poisoned with arsenate of lead at the rate of 10 pounds to 100 gallons of water. This can be applied with any of the common force pumps.

Natural Enemies

(The numerous parasites which the entomologists of the Department of Agriculture have imported, it is stated, are beginning to control this pest.—Ed.)

Hag Moth*Phobetron pithecium*

This is a slug-like caterpillar of very singular form, sometimes found upon apple, oak and wild cherry. It reaches a length of 0.60 inch. Extending out from each side of its body are four long tentacle-like curved and tapering fleshy processes. The color is dark brown. The adult is a purplish brown moth, with a stretch of front wings of a trifle less than one inch.

The insect pupates in a papery cocoon upon the outside of which are attached the long processes from the body of the caterpillar. These bear nettle-hairs which have been thought to protect the enclosed pupa from enemies. The cocoons are attached to twigs and bark.

The insect is interesting chiefly because of its singular appearance. It is never common.

Hickory Tiger Moth*Halesidota caryae*

So called because of the color and spotting of the wings. The caterpillars are about one and one-half inches long and have a row of eight black tufts along the back, and two long black pencils, each on the fourth and tenth segments. Orchards sprayed for codling moth will not be troubled.

Ivy or Oleander Scale*Aspidiotus hederae*, Vall.

General Appearance.—Circular flat scale, one-sixteenth to one-eighth of an inch in diameter, the male scales being very much smaller. The color varies from light to dark gray.

The life history is the same as the San Jose scale. It is distributed generally throughout the country.

Control.—Same as San Jose scale. A small chalcid fly works effectively on this scale.

E. O. ESSIG,
Cal. Hort. Com.

LEAF CRUMPLER.—See *Apple Leaf Crumpler*, this section.

LEAF HOPPER.—See *Apple Leaf Hopper*, this section.

LEAF MINER.—See *Trumpet Leaf Miner*, this section.

LEAF ROLLER.—See *Oblique Banded Leaf Roller*, this section.

LEAF SEWER.—See *Apple Leaf Sewer*, this section.

LEAF SYNETA.—See *Fruit Tree Leaf Syneta*, this section.

LECANIUM.—See *European Fruit Lecanium*, this section.

Lesser Apple Leaf Folder*Acleris minuta* Rob.

This leaf folder commences work with the opening of the leaves. The eggs for the spring brood are laid by a small slate-gray moth and hatch into small green worms, having pale brown or yellowish heads with white markings. The opposite edges of the young leaves are drawn together upwards and fastened with a silken web, thus forming a roofed chamber within which the caterpillar lives. Like all of its family, when alarmed, it deftly lowers itself to the ground by means of a silken thread. It is controlled by the lime-sulphur wash.

H. A. GOSSARD

Lesser Apple Worm*Enarmonia prunivora* Walsh

During the past few years the species known as *Enarmonia prunivora* has been found very commonly infesting the fruit of the apple in various parts of the United States, in some sections so abundantly as to cause serious loss to orchardists, the insect ranking in importance as an apple pest close to the codling moth.

The small, fusiform, flesh-colored larvae, about three-eighths of an inch long, injure the fruit around the calyx by eating out shallow cavities or boring holes into the flesh from one-fourth to one-half inch or more in depth, in the ripening fruit occasionally penetrating to the seeds. The surface of the fruit, especially in the calyx basin, is also injured, the larvae working beneath the skin and eating out galleries or large blotch mines, frequently with holes or borings extending more deeply into the flesh. The work of this species resembles rather closely that of the codling moth, and the similarity of the larva to the codling moth larva and the further similarity in the life his-

tory and habits of the two species have doubtless been responsible for the almost complete oversight in the United States of this species as an important enemy of the apple.

Control

The common measures used against the codling moth have served to keep this species in check.

Lime Tree Winter Moth

Erannis tilharia

The females are wingless and late in October or early in November may be seen ascending the trunks of trees. They are spider-like creatures with yellowish white bodies.

Band with tree tanglefoot to prevent their ascent.

Mediterranean Fruit Fly

Ceratitis capitata Wiedemann

H. F. WILSON

In countries where this pest has gained a foothold it is one of the greatest insect enemies of fruit raising. At the present time it is believed that Brazil is its native home. Adults have been reared from apricots, peach, pear, plum, apple, fig, oranges, lemons and a number of other important fruits.

Means of Distribution

From evidence gathered in various sources the pest is distributed in fruit. An extract from bulletin 28 of the Department of Agriculture, Cape of Good Hope (South Africa), will show the danger to fruit growing in the United States should it gain a foothold. "It is no doubt carried into distant localities in infested fruit. Visit almost any morning market in the Colony after apricots and peaches are ripe and you can find maggots and puparia in abundance. That this fruit is purchased and shipped to other places, or carried away in small lots goes without saying. While visiting one of our most important markets on a Saturday morning during February, 1904, I found loads of infested peaches. There was absolutely no sale for the most of them, and the growers in disgust dumped them out on the ground. I said nothing, for, in the first place, I had absolute-

ly no right or authority in the matter, and secondly, I wished to note the course of events. They were being removed by 7 o'clock Monday morning, but the ground for yards around was dotted white with maggots trying to hide away for transformation, and puparia could be picked up by the hundred. Under such a deplorable state of affairs it is quite possible that some of the adults would again find their way into wagons and be carried away to distant farms."

The adult fly is yellowish with black and white markings. Both wings being banded with yellow and with a series of black lines toward the base. The abdomen is yellow and is crossed with two white bands.

The larvae or maggots resemble those of any of our common flies, such as the cabbage root maggot.

The life history in general is about as follows. The eggs are deposited in the fruit by means of the sharp ovipositor with which each female is furnished. As soon as they hatch, the young larvae at once begin to feed on the pulp of the fruit. When fully developed, which usually requires about three weeks, they leave the fruit and enter the ground where they change to puparia and later to adults. The adults push up through the soil and in a short time are ready for work. A very efficient remedy has been found for this insect in South Africa which prevents the adults from depositing their eggs.

MITES.—See *Red Spider*, this section, and *Blister Mite*, under *Pear*.

Oblique-Banded Leaf Roller

Cacoecia rosana Harris

H. F. WILSON

Appearing on various plants throughout the United States we may expect to find the larvae of this insect working on the leaves of all our cultivated pome, bush and small fruits. In extreme cases some little damage may be done to apples and pears. In these cases the skin of the fruit is eaten and even holes are made in the fruit which makes it unfit for sale.

The adults have a wing expanse of about one inch. General color leather colored

brown with one opaque dusky band, beginning at the middle of the anterior margin and extending to the inner angle of the wing.

The larvae are pale green to reddish brown in color, with a dark brown head and a few sparse hairs rising from the head and body. The larvae of this insect should not be mistaken for that of the bud moth, which is a very abundant insect in Oregon found working in the buds. The larvae of this insect works on the leaves.

Remedies

Should this insect become abundant at any time it may easily be controlled by an application of spray as used for the codling moth.

OLEANDER SCALE.—See *Ivy Scale*, this section.

Oyster Shell Scale

Lepidosaphes ulmi Linn.

H. F. WILSON

Probably as widely distributed as the San Jose scale, this insect is the cause of much injury to fruit trees throughout the United States.

It is not supposed to be as serious a pest as the San Jose scale, but is of considerable economic importance. Entire trees are seldom killed, but oftentimes single branches will become so weakened from their attack that they will not produce fruit and may die, and at times small trees become so stunted as to never grow into well balanced trees. Besides our fruit trees this insect infests a large number of shade trees, vines and bush fruits. The adult scales measure about one-eighth inch in length and are dark brown in color. In early spring these may appear grayish brown, due to bleaching by the winter rains. When present in large numbers the scales will overlap and assume various curved shapes. Apparently with the beginning of fall the entire abdomen of the female develops into eggs and the insect itself shrivels up and dies. If during the winter one of these scales be turned over, 50 to 100 small white oval eggs will be exposed to view.

These eggs hatch about the time the blossoms of the apples are falling, and

the young crawl from under the scales and settle on the bark. The female molts twice in her growth according to Quaintance and Marlatt, and in the adult condition is entirely without legs or eyes, and is but a jelly-like mass, capable only of extracting sap from the tree and changing it into eggs.

The adult male undergoes similar changes under its scale but later assumes



Fig. 1. The Oyster Shell Scale.

legs, wings and antennae, and emerging from under the scale flies about fertilizing females.

In its distribution from orchard to orchard, nursery stock probably plays the most important part, although other insects, birds, etc., may and do aid in the distribution from tree to tree.

Remedies

It has been stated that lime sulphur will not destroy the egg of this pest but we have observed that where this spray is consistently used for the San Jose scale that the oyster shell scale does not thrive and no extra application is needed. No doubt but that the eggs are very tenacious of life and hard to kill, but we believe that the insect can be held in check with the above spray.

Shade trees and low-growing plants, as currant, gooseberry, etc., often become so badly infested that it seems necessary to apply a spray. In such cases kerosene

emulsion is used, and is applied just as the eggs are hatching in the spring. Considerable difficulty may be experienced here as the young are at that time considerably protected by the foliage. To secure the best possible results a high pressure pump should be used by means of which a pressure of 150 to 200 pounds can be secured. Apply spray to all parts in as thorough a manner as possible. (Use kerosene emulsion 8 to 10 per cent strength.) For preparation of kerosene emulsion see sprays for aphids.

PEAR BLIGHT BEETLE.—See *Shot Hole Borer*, under *Cherry*.

Periodical Cicada

Tibicen septendecim Linn.

H. F. WILSON

There are probably very few of us who are not acquainted with this insect in the adult stage on account of the large numbers which appear at one time or another in various sections of the country. The name is applied on account of the fact that the adults only appear at periods of every 17 or 13 years. In the northern part of the United States it is 17, in the south 13. During the intervening time they live in the ground as nymphs and live by sucking the juices from the roots of trees. Having reached that point where they are ready to become adults, they crawl out of the ground and on to a stone, tree trunk or anything above ground, and shedding the skin for the last time, come forth as adults.

After leaving the old shell they are ready to fly about in a day or two, and within a week the sexes have mated and the females shortly proceed to make their

egg punctures and deposit eggs here and there in the twigs.

In selecting trees for egg oviposition oaks are shown a preference and among fruit trees apples seem to be preferred. Almost any plant may be attacked.

The part of the plant selected is almost invariably the twigs of the previous year's growth. Occasionally a single nest or two will be constructed in a larger limb.

The result of such work must of a necessity be quite detrimental to the trees as the twigs are often so weakened that they break very easily and an excessive pruning results. In the nursery considerable damage may be caused by the after-effect, which is shown in the deformities of slow-healing wounds. These wounds offer excellent entrance ports for fungus diseases and other insects. The woolly apple aphid oftentimes locate in these scars and instead of healing over they become more deformed and susceptible to the attacks of fungus and insects.

In depositing her eggs the female cicada passes from one limb to another until she has deposited all of her eggs, which have been estimated to number from 400 to 600. The eggs measure about one-twelfth inch in length. They hatch in six or seven weeks, are pearly white in appearance, tapering to an obtuse point at either end and slightly curved. Upon hatching from the eggs the young larvae run about for a very short time, drop to the ground where they seek out a crevice and immediately work their way into the soil and begin their long underground existence.

Remedies

A number of insecticides are quite effective against this species, but to be of real value must be applied each day as long as the insects issue in numbers. Pyrethrum powder is a perfectly satisfactory remedy against newly transformed individuals. This should be applied in the morning, before the insects have gained full strength and while the plants are wet with dew. The powder may be puffed on the insects while clinging to shrubbery or on the lower branches of trees. This powder is absolutely worth-

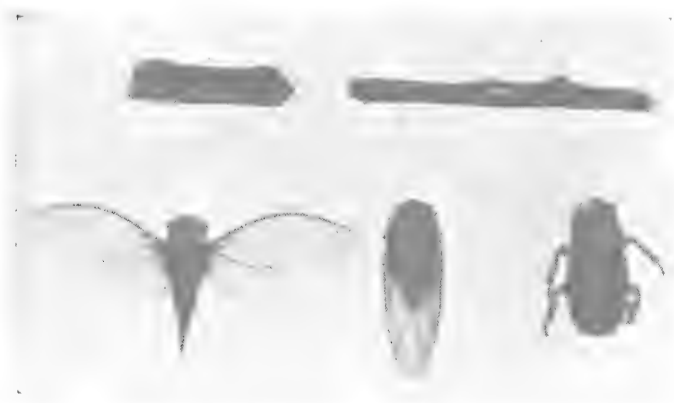

Fig. 1. Periodical Cicada: Egg punctures in twigs; pupal case and adult insect. (After Cordley.)



Fig. 2. Periodical Cicada: Section of sod with pupal gallery extension above ground. (Original.)

less against the pupae. Some experiments carried on by the United States government show that newly emerged pupae may be destroyed by spraying with a 2 per cent solution of carbolic acid or a 15 per cent solution of acetic acid.

Coating the trees with whitewash or spraying with a strong solution of lime-sulphur offers a possible protective means against egg deposition, as it has been stated that the cicadas do not like to sit on a white surface.

Phenococcus

P. dearnessi

The immature insects hibernate under the rough bark of apple trees. Eggs are laid in early summer, the young migrating to the under side of leaves. The insect secretes a cottony substance as shown in the illustration.

The usual remedies for scale.

Rabbits

By H. F. WILSON

The first suggestion would be to remove all brush piles and thickets and other places which offer hiding places or may serve as breeding places.

Repellents

Perhaps the easiest to apply and about as efficient as any repellent is the com-

mon lime-sulphur spray applied to the trunks of the trees so as to drench them.

The Arkansas Experiment Station recommends painting the trunks of trees in the fall with white lead and linseed oil. Mixed paints should not be substituted for the above, as they may contain oils which would injure the trees. This seemed to give very satisfactory results and had the advantage of remaining on the trees for an entire season.

The Oklahoma Station recommends the following formula which they found very satisfactory: "Water one gallon, one pound soap, two to four ounces of carbolic acid." Some prefer to add enough vermilion red to give the mixture a good pink color and the consistency of cream. This is painted on the trunk of the trees in the fall with a brush or swab of rags tied to a stick.

Tree Protectors and Wrappers

Wire window screen and fine chicken fence wire may be used with success in case of small trees. They should be about two feet high and should be allowed to stand out a short distance from the tree. The tubes should be fastened with wire.

Wooden veneer strips or some of the ready-made protectors may be used with



Phenococcus dearnessi.

success. In case of veneer they should be soaked in water before attempting to bend them around the trees. Where there are only a few trees, as around the home yard, the most satisfactory method of pro-



Hawkeye

Fig. 1. Veneer Strips of Ready-made Protector.

tection is to wrap them with papers; cornstalks, burlap, etc., may be used, but these must be removed during the summer as they furnish a harboring place for insects.

Traps

There are any number of these which are very easily made and are very effective. This method is not as economical as poisoning but is frequently used.

Poisons

Poisons have the advantage of being easy to make and place, but may be dangerous to domesticated animals. Two formulas are included, any one of which will do.

1. Sulphate of strychnine one part, borax one-third part, white syrup one part, water ten parts. Put the mixture into a jar or large bottle and mix well. Cut fresh twigs, water sprouts of apple are best, and with a small brush paint them, especially over the terminal bud, with the above preparation.

2. The Western Australia Department of Agriculture recommends a similar formula: Dissolve one and one-half ounces of strychnine in one quart of vinegar,

dilute with five gallons of water, add two pounds of flour and one pound of sugar, stir well and apply to twig as in first poison.

RAILROAD WORM.—See *Apple Maggot*, this section.

RED BUG.—See *Apple Red Bug*, this section.

Red-Humped Apple Tree Caterpillar

Oedemasia concinna S. & A.

H. F. WILSON

As yet this insect has not reached a very important status as a pest, but it is more or less generally distributed in fruit growing sections of the United States. At times they may get into an orchard and strip a great many branches, as they are voracious eaters, feeding on apple, plum, cherry, rose, thorn pear, blackberry, birch, poplar, etc.

The adults are moths of rather a mixed brown color, fore wings dark brown on the inner and grayish along the outer margin. The thorax and abdomen are brown. The moths appear in the middle of the summer and deposit their eggs in clusters on the under side of the leaves. From these soon hatch little larvae or worms, which feed on the under side of the leaf. Later as they grow larger, the whole leaf excepting the midrib, is devoured. In October they become full grown, descend to the ground, crawl under leaves or rubbish, where they construct a clear transparent cocoon, and remain until the following spring, when they appear as moths.

The full grown caterpillar measures about one and one-fourth inches in length. It is marked with fine longitudinal stripes of black, white and yellow. Head bright red, and contracting upward and backward. Body covered with black tubercles, which on the dorsum carry black spines.



Fig. 1. The Red-humped Caterpillar. (Much Enlarged.)

The fourth body segment is raised dorsally to form an oval red hump from which the insect gets its common name.

Remedies

Arsenicals applied to the leaves are efficient and probably the reason that we seldom hear of this pest doing serious damage is because they are poisoned by the sprays used for codling moth, etc.

Red-Necked Apple Tree Caterpillar

Datana ministra

A moderately large black caterpillar, loosely clothed with soft hairs, and marked with parallel longitudinal yellow stripes. Disposed to be social, but makes no web. Adult a reddish brown moth.

Sometimes attacks a tree or two in nursery or orchard, and then strips whole branches, or the greater part of whole trees, of leaves. The caterpillar when at rest elevates both head and hind end of the body and has a habit of gathering in large masses on the trunks of trees.

The species passes the winter in the pupa stage in the soil under trees, and comes up as a moth in late spring to place its eggs on the leaves.

Not noted in the Northwest.

Burn with kerosene torches or spray with arsenate of lead.

Red or Six-Spotted Spider or Mite

**Tetranychus bimaculatus* Harv.

Tetranychus sexmaculatus Riley

General Appearance

This species (like the other mites) is exceedingly small and individuals are seldom noticed excepting when they collect in great numbers. The color is red with a yellowish tinge and usually with two darker spots on each side of the body. The young greatly resemble the adults but have six rather than eight legs.

Life History

The mites usually begin to appear after the first warm weather in the spring, the winter having been spent in the ground. They spin threads so as to conceal themselves, their eggs and young, on

*We are informed by Dr. H. E. Ewing that the correct name of this species is *Tetranychus telarius* Linn.

the undersides of the leaves and feed directly upon the tissues of the plant by sucking which gradually stunts and kills the latter. The common red mite is a serious greenhouse pest, where, under favorable conditions, it is able to work throughout the entire year.

Distribution

Though of foreign origin this mite has become thoroughly distributed over the entire state and is met alike in field and greenhouse.

Food Plants

This mite is an omnivorous feeder, apparently without any favorite food. The plants which it is known to attack are sugar beets, beans, sage, tomato, egg-plant, pepper, cucumber, squash, cowpea,



Fig. 1. Mite Eggs About an Apple Bug.

hops, berries, violet, rose, clematis, mig-nonette, pink, fuschia, pelargonium, godetia, passiflora, feverfew, thunbergia, verbena, heliotrope, moon-flower, calla, smilax and easter lily.

Control

Sulphur and dehydrated lime mixed in equal proportions and thoroughly sprinkled over the plants are recommended. Sprays such as emulsions, resin wash and soap solutions are efficient remedies, but these are usually too destructive to the tender leaves of the food plants to be practicable. The flour paste spray is especially recommended in such cases.

Natural Enemies

The minute black ladybird beetles (*Stethorus vagans* and *Stethorus picipes*) and the larvae of the syrphid flies prey upon this mite.

E. O. ESSIG

Resplendent Shield Bearer

Coptodisca splendoriferella

This leaf miner attacks apples, quince, and native hawthorns. When the larva is ready to change to a pupa, it cuts out the part of the leaf it has mined and drags it away to the twigs, where it is secured as a small cocoon about one-eighth inch in length, and remains with the enclosed pupa until the following spring.

The larva is legless, flattish, the head dark brown, the body lighter brown with a darker shade along the middle above and beneath.

The adult is a beautiful little moth, the head and outer half of the front wings golden, the bases gray. A silvery streak extends inward from both anterior and posterior margins of the front wing toward the tip, but they do not meet.

The insect is not very common and those I have secured have been badly infested with a small yellow and black Hymenopterous parasite.

H. GARMAN

ROSY APPLE APHIS.—See *Aphids*.

Saddle-Back Caterpillar

Sibine stimulea

A slug-like caterpillar with four conspicuous horn-like spiny processes, one at each side near the front end of the body and the other pair near the hind end. There are other smaller processes at each end. Body purple in front and behind, between, pea-green, with an oval, saddle-like area in the middle of the back, the green surrounding it having some appearance of a saddle blanket. Length about one inch.

The pupa is found in a brown papery cocoon, formed against branches or other objects.

The adult moth expands about 1.44 inch. The fore wings are of a deep reddish brown color; hind wings, much paler.

The insect is never common enough to

be the occasion of any anxiety. Besides apple, it feeds upon oak, cherry, corn, and other plants.

The San Jose Scale

Aspidiotus perniciosus, Comm.

BY H. F. WILSON

Nature and Extent of Injury

One can hardly fail to locate this insect where it is present in unchecked numbers, for the appearance of its host will be such that one who is familiar with the resulting injury can readily distinguish the more or less circular ash-gray, shield-like scales on bark, leaves or fruit. Owing to the fact that the scales closely resemble the bark of most of our fruit trees, they may be working on a tree for some time before their presence is discovered. When they are abundant, the fruit will usually be infested with few to many scales; this is the first indication that the average orchardist will notice. When allowed to develop unchecked, they soon cover branches and limbs, which, as a result of the injury, die in one or more seasons; following this, entire trees die from lack of nourishment.

It has been said that the San Jose scale is the only scale which causes the reddening of the bark, but this is not true as the same effect is caused by other scale insects. This is quite characteristic of



Fig. 1. San Jose Scale.
(Enlarged)

the San Jose scale, however, and furnishes a fairly sure basis for identification in the orchard.

The condition of the scales can readily be ascertained by scraping them from a branch; if they are dead, the scales will rub off like a dry, gray scurf; if they are alive, the crushed bodies will produce a yellow oil-like fluid which gives the bark a greasy appearance. Wherever a scale has settled there will be a small round spot with a white speck in the middle; the spot is formed by the body of the scale while the white speck is where the long thread-like piercing apparatus, or tongue, was inserted in the bark. Oftentimes the scales will completely cover portions of limbs and overlap on each other so that they form a crust. When so badly infested, young scales will crawl under old dead scales and settle. We have found as many as four young scales fastened side by side under one old scale. Fruit infested with the scale becomes pitted and gnarled, as the growth is checked at the point where the scales have their beaks inserted.

"For the benefit of fruit inspectors in particular, it should be noted that reddish discolorations upon yellow fruit are not always caused by San Jose scale. Upon yellow apples and particularly upon peaches very similar spots are produced by attacks of certain minute fungi. Hence, such spots should not in themselves be taken as proof of infestation by the scale. This can be determined definitely only by a careful examination and the actual detection of the scale. The presence of such blotches may well arouse suspicion of the presence of San Jose scale and should challenge a careful examination alike by growers, buyers and inspector; so, also, should the presence of dead and shriveled leaves upon the trees in mid-winter invite examination, for, although their presence is not proof of the appearance of the scale, it is evidence that the vitality of the tree has been seriously impaired by some cause, and in regions where San Jose scale is prevalent that cause, in a vast majority of instances, is the scale." (1)

(1) A. B. Cordley, Bull. 88, Ore. Agr'l Ex. Sta., p. 6, March, 1906.

Unlike most other scale insects, it develops and hatches its eggs within the body, so that the young are born alive. In May, possibly earlier, under favorable conditions, the females begin to give birth to living young and may continue to produce for six weeks or longer.

General Description

The young are minute, light orange yellow, active creatures with eyes, bristle-like mouth parts, two antennae or



Fig. 2. San Jose Scale on Apple Limb. (Purdue Bulletin 138.)

feelers, and six legs. After emerging from under the protecting scale of the parent, each wanders over the surface of bark, fruit or leaf until a suitable situation is found, when the legs and antennae are folded beneath the body, the bristle-like beak is slowly worked through the outer bark into the living tissues beneath, from which it draws its sustenance. At any time during the summer months hundreds of these little pests may be seen, even with the unaided eye, as they crawl about over the bark or fruit of infested trees. With the first molt, all appendages, the legs, antennae, etc., except the beak, are lost.

The female scales when mature have a more or less circular scale formed of a number of concentric rings, which correspond to the various molts made during growth. Under a strong lens these appear ash-gray in color with a black protuberance or raised spot in the middle.

Remedies

In this state lime-sulphur is generally used in combating the San Jose scale. The recommendations from this station have been to spray the trees while dormant either in the late fall or early spring.

"During the past four years we have conclusively demonstrated that the lime-sulphur spray, which has long been known as the most satisfactory winter spray for San Jose scale, has fungicidal qualities nearly or quite equal to those of Bordeaux. We have also conclusively demonstrated that it may be used in combination with arsenate of lead without detracting from the value of either, and that when so used it is at once an efficient contact insecticide, food poison, spray and fungicide." (2)

We have also demonstrated the fact that Black Leaf or "Black Leaf-40" can be combined with lime-sulphur, in control of plant lice without destroying the insecticidal value of the lime-sulphur. The most suitable time to get plant lice is in the spring, just as the buds are turning green. At that time a very large

percentage of the eggs will have hatched and the young lice will not be protected by the leaves. The lime-sulphur is equally as effective in the control of the scale when applied at that time and to a slight degree may be effective against the newly hatched lice.

General Recommendations

It is not necessary to make an application of lime-sulphur for the San Jose scale alone. If lime-sulphur is used at any time for the control of apple scab or anthracnose, the same application will suffice for the control of the scale.

In regions where neither of the above diseases exist, spray with lime-sulphur, winter strength, just as the buds are opening, and if the plant lice (any species) have been bad during past seasons, add "Black Leaf-40" at the rate of 1 part to 900 parts of the diluted lime-sulphur spray.

Scurfy Scale

Chionaspis furfura Fitch

General Appearance

The female scale is irregular and broadly pear-shaped; from white to light gray in color. The exuviae is yellowish and from one-eighth to one-tenth of an inch in length. The male scale is white, very small, long, tricarinated and with yellow exuviae at the pointed end.

Life History

The winter is passed by the females under the scales where the purple or wine-colored eggs are laid and hatch in the spring shortly after blooming time. The young begin at once to cover their bodies with a scale.

This insect is sometimes confused with the oyster shell scale, but is broader and much lighter in color, having dark red eggs, while those of the oyster shell scale are yellowish-white.

Food Plants

This species attacks many plants, chief of which are apple, pear, plum, cherry, quince, Japanese quince, currant, mountain ash, hawthorn, peach, poplar, gooseberry, crabapple, chokecherry, black walnut and elm.

(2) A. B. Cordley and H. S. Jackson, Cir Bull No. 13, Ore. Agr'l College, 1911.



Fig. 1. Scurfy Scale. Purdue Bulletin 118.

Control

Same as for San Jose scale.

E. O. ESSIG

SEVENTEEN-YEAR LOCUST.—See *Periodical Cicada*, this section.

SIX-SPOTTED SPIDER.—See *Red Spider*, this section.

SYNETA.—See *Fruit Tree Leaf Syneta*, this section.

Tent Caterpillars

Malacasoma erosa Stretch.

Malacosoma pluvialis Dyar.

Malacasoma constricta Stretch.

By H. F. WILSON

Tent caterpillars, so-called because they build nests wherein they usually remain when not feeding. These nests are formed

out of silken threads secreted by the larvae and serve both as a shelter and a protection against natural enemies.

Of the many different species which exist throughout the world only three are at all serious in the Northwest. To the casual observer there is little difference between the larvae and adults of these species when looked at separately. Taken side by side, however, the full-grown larvae may be easily distinguished, one species from the other.

*According to Professor F. L. Washburn, a former entomologist of the Oregon Agricultural College, of the three, *Malacosoma erosa*, *Malacosoma pluvialis*, and *Malacosoma constricta*, the first named feeds upon almost everything but the pear, viz.: apple, quince, cherry, rose, prune, etc. The second has about the same food plants as the first. The third devastates whole groves of oak, particularly *Quercus garryana*, occasionally migrating to the prune, and thereby causing considerable alarm among orchardists.

During the past two or three years *M. pluvialis* has been extremely abundant in the western part of Oregon, both on fruit and forest trees. Numerous reports have come in from about Portland and I have observed the larvae over many square miles of woodland in Southern Oregon.

When these larvae are very numerous they can entirely strip a tree of its foliage in a very short time. When first hatched from the eggs they are not readily noticed, but as they grow larger they are readily distinguished both by their size and by the tents which they build. Toward the middle or latter part of the summer the larvae become full grown; they then seek crevices where they spin silken cocoons and change to pupae. After remaining in this stage a short time they change to the adult insects or moths which come forth and deposit the eggs. The eggs are deposited in masses on the small branches or shoots, and in the case of one species, where the eggs are laid on new shoots, the egg mass completely surrounds the twig. These are covered

*F. L. Washburn. Bulletin 33, Oregon Experiment Station, 1894.

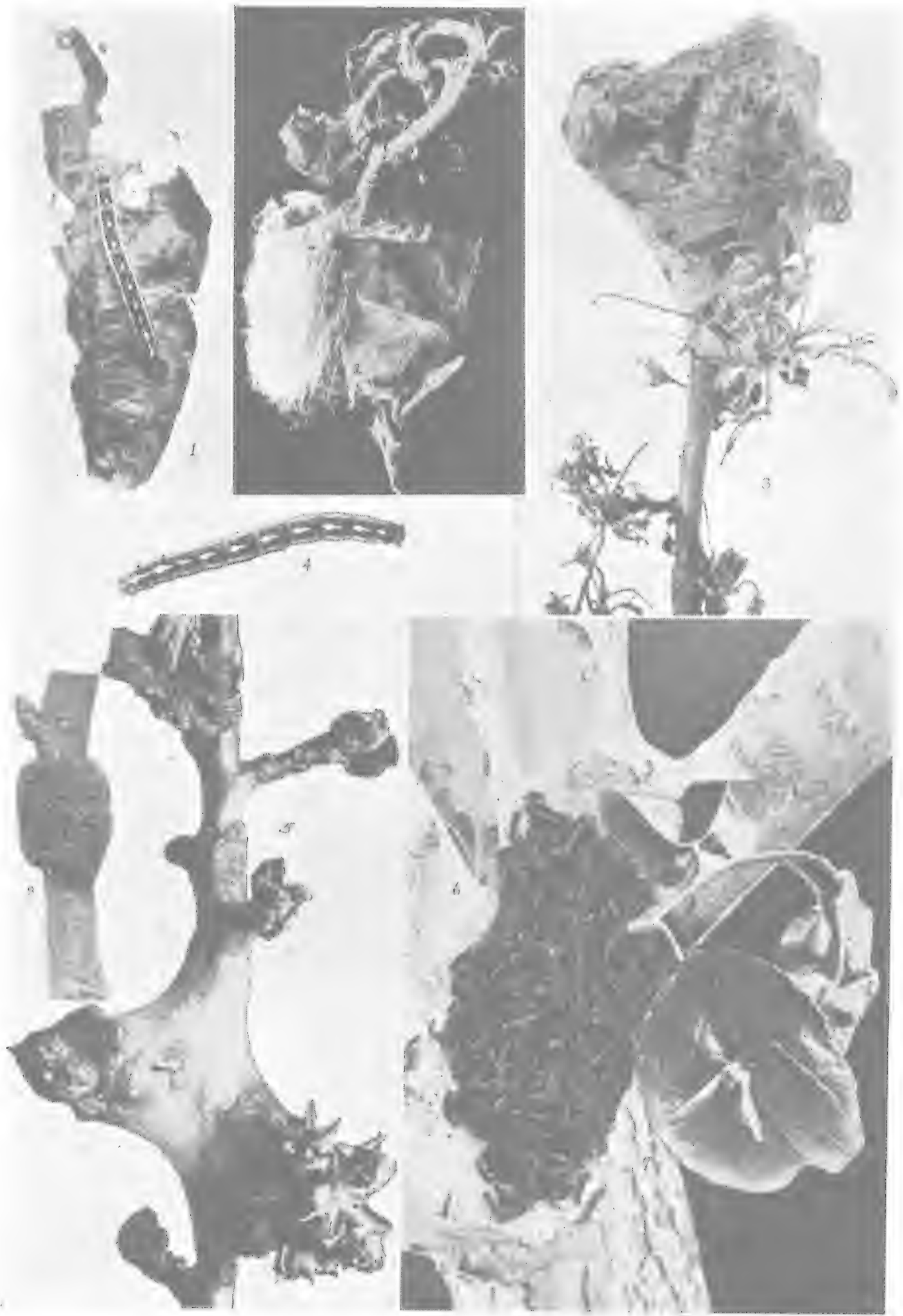

Tent Caterpillars. 1 and 4, larvae of *M. erosa*; 2, cocoon of *M. erosa*; 3, tent of *M. erosa*; 5, egg mass and nest of *M. pluvialis*; 6, cluster of caterpillars on trunk of apple, *M. erosa*; 7, adult of *M. erosa*; 8, egg mass of Western Apple Tree Tent Caterpillars.

with a cement-like substance which is impervious to water and climatic conditions. This gellatinous substance, besides acting as a protection to the eggs, is said to constitute the first food of the newly hatched larvae. The embryonic larvae in these eggs are nearly full fledged at the beginning of winter and usually come forth from the egg mass early in the spring. All of the moths do not emerge at the same time, so that we may find them laying their eggs until late in the fall. The eggs of the late appearing moths do not hatch until a correspondingly late period in the summer; therefore, we may find some caterpillars and nests all through the summer. This might seem to indicate that there is more than one generation a season but such is not the case. The adult moths are about one inch long and are cream colored with indistinct white bands on the wings.

Natural Enemies

Like every other species of animal life these insects have their natural enemies, and large numbers are destroyed each season. Few birds feed upon hairy caterpillars, but according to Professor Washburn, the Brewers' Blackbird, very common in this country, is very fond of the pupae, and may be observed tearing open the cocoons and feeding on them. They are also attacked by a fly, which lays eggs on the larvae. From these hatch minute worms which bore into the insects and feed on the tissues, thus eventually killing the host. There is a fungus disease prevalent in Oregon which is very disastrous to the insects under the right condition. This is induced by warm wet weather when the larvae shrink up and die.

Artificial Methods of Control

In fruit orchards, spraying with arsenate of lead, as used for the codling moth, is usually sufficient. As the egg masses remain over the winter on the twigs the majority of the nests can be destroyed at the time of winter pruning. If these nests are not located in the winter and the caterpillars form tents in the spring, the tents can be burned out with a torch. Shade trees may be protected by spraying

with arsenate of lead, 2 pounds to 50 gallons of water.

TINGIS.—See *Apple Tingis*, this section.

Trumpet Leaf Miner of the Apple *Tischeria malifoliella* Clemens(?)

H. F. WILSON

This insect is of little economic importance to fruit growers in the Northwest, but sometimes appears very numerous on the leaves of apple and is often inquired about.

Little mines are made in the leaves by the larvae, which begin at the point of egg deposition and gradually widen out in the shape of a trumpet. Completed mines vary much in shape and size, but will average perhaps in the more typical examples one-half inch long by one-fourth inch wide.

The larva is whitish in color with a brown head, and measures about one-quarter inch in length at the time of pupation. The adult was originally described as follows: "The head and antennae shining dark brown, face ochreous. Fore wings uniform shining dark brown with a purplish tinge, slightly dusted with pale ochreous citio of the general hue. Hind wings dark gray; cilia with a rufus tinge."

When excessively abundant, as has been the case in several localities during the past two or three years, the injury done by the larvae to the leaves will cause many of them to fall prematurely, thus interfering with the proper development of the fruit and the health of the tree. Its control, therefore, becomes a matter of importance. This can, perhaps, best be accomplished by plowing the orchard in the spring, covering as much as possible all the fallen leaves and trash, as in the former the pupae pass the winter. This having been done it is practically certain that the moths will not be able to make their escape from the soil. This should be done not later than the blooming of the trees.

TUSSOCK MOTH.—See *Western Tussock Moth*, this section.

TWIG BORER.—See *Branch and Twig Borer*, this section.

Unicorn Prominent

Schizura unicornis

During August and September, a singular caterpillar is occasionally found feeding on apple foliage. It is reddish brown, variegated with white on the back, and has a green patch on each side, extending over the second and third segments, while from the top of the fourth a conspicuous horn is projected. It eats out a notch from the edge of the leaf and then fits itself to the notch, clasping the eaten edge of the leaf with its prolegs while the prominent horn is made to extend over a portion of the vacant space where belonged the devoured tissue. The outline of the back, thus simulating the irregular edge of the leaf, enables the caterpillar to elude the sight of all but the most searching eyes. This caterpillar is known as the unicorn prominent, and though interesting, rarely, if ever, becomes sufficiently numerous to be troublesome. It reaches full size in September and descends to the ground, where a cocoon is constructed under the fallen leaves and trash. The light-brown moth does not appear until the following summer. No measures against this insect are needed under ordinary circumstances. If a midsummer spraying with arsenate of lead is made in July or August, these caterpillars are apt to be thinned down until they attract no notice.

H. A. GOSSARD,
Wooster, Ohio.

WEEVIL.—See *Bronze Apple Tree Weevil*, this section.

Western Tussock Moth

Hemerocampa vetusta Boisd.

H. F. WILSON

The distribution of this insect in the United States is at present limited to the Pacific coast, and on account of the similarity of its work to that of the tent caterpillars, is often taken for one of those insects. The two are quite different, however, in appearance, both in the larval and adult stages.

The eggs begin to hatch about the time the leaves are spreading out in the spring, and at that time the young larvae are almost black. For a few days they re-



Fig. 1. Western or California Tussock Moth. (a) and (b) Adult wingless females. (d) Cocoons. (e) Egg masses attached to the cocoons. (f) Eggs. (g) Internal parasite working upon cocoons. (Essig.)

main clustered about the egg mass and apparently feed on the substance which covers and holds the latter together. After the larvae have all hatched and have broken out from the eggs, the egg mass will appear as if riddled with holes. The larvae cut these in escaping from the eggs.

After a few days the larvae spread on to the nearby buds and leaves. At first the damage is very slight and consists of minute holes in leaves, blossoms and fruit. Later they feed entirely on the leaves which they devour, leaving only portions of leaves and the larger veins.

Unlike the larvae of the tent caterpillars, they spread out over the tree and do not collect at night nor do they build nests or tents. They are somewhat wandering in their habits and oftentimes can be seen crawling about on the ground, going from one tree to another.

The original description of the larvae is given as follows: "Ground color velvety black. Head black, rather shining, with yellow line in front. From the second segment springs two bundles of long black hairs. The space between these is bright vermilion red; at the base of each



Fig. 2. Western Tussock Moth: Larva feeding on Apple Foliage. (Original.)

segment is a series of four or five orange yellow dots, extended to the sides; third and anterior part of fourth more broadly and distinctly patched with orange. From the dorsum of fifth, sixth, seventh and eighth spring bundles of long silky hairs, whitish drab at their base, chestnut towards their tips. Along the lateral region is a double row of bright red tubercles, and on the third, fourth, tenth, eleventh and twelfth, these extend across the body, six tubercles appearing on each segment. Out of these spring a series of long yellowish white hairs, sparsely interspersed with black, and becoming more decidedly yellow laterally. From the center of twelfth segment a bundle of long yellow hairs, tufted with black; under side blackish; feet and pro-legs orange yellow, with the claws black. Length one inch."

When mature the larvae usually seek

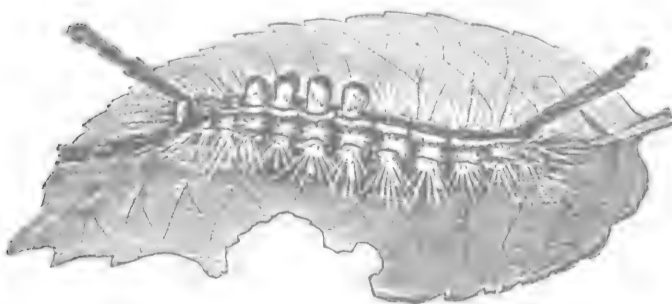

Fig. 3. White Marked Tussock Moth. An Eastern relative of the Western species.

some protected place for forming their cocoons and in such a place collect in large numbers if very abundant. Occasionally they will gather bunches of leaves at the tip of twigs and form their cocoons under these; this takes place in early June. About the last of June the females and males emerge, copulate; and the females being unable to fly, remain hanging to the old cocoons. The males fly both at night and during the day; they live but a short time after copulation.

It has been stated that the males are attracted to the females by their odor and that they will go long distances to find them. As the eggs are deposited the females secrete a cement-like substance which surrounds the eggs and forms an excellent protection against climatic conditions and enemies. This also fastens them very securely to whatever they are laid upon. As the eggs pass from the body the abdomen contracts until the female is but head and legs with but a semblance of an abdomen. The egg masses are grayish brown in color, nearly spherical and measure about one-fourth inch in diameter. There is but a single brood each season and the eggs remain over until from early summer to early spring. There is little danger that this insect will ever become a very serious pest but it is at all times annoying and may at times need special treatment.

Remedies

Our most common spray of arsenate of lead, 2 pounds to 50 gallons of water, is



Fig. 4. Dead Caterpillar of the California Tussock Moth Moved to Show the Pupa Cases of Internal Parasites, Which After Killing it Pupated Underneath the Dead Body. (Essig)

entirely ineffective and Paris green is not much better. Contact sprays seem to be inefficient and there remain but two methods that offer any great chance of success; one is to collect or to destroy the egg masses.

Second, by placing sticky bands on the trees and then jarring the trees. These may be made of tangle foot or some tar compound. Jarring the trees will cause the larvae to drop to the ground and when the trees are banded they cannot get past the bands as long as they remain fresh.

White Dotted Apple Worm

Balsa malana

In early fall and continuing until late autumn may sometimes be found a rather stout, cylindrical, light-green worm, about an inch long and marked with five white longitudinal lines and numerous whitish dots. These worms are in the habit of feeding solitary and alone on the underside of the leaves, from the margins of which they eat regular notches or holes into the middle. This caterpillar is known as the white dotted apple worm. When full grown, the caterpillar draws together a portion of the leaf with silken threads to form a hollow tube. This is lined with a thin layer of silk and the caterpillar then passes into the pupal stage. The chrysalis remains in the fallen leaf until the next spring, when it issues as an ashy gray moth with three irregular black lines crossing the front wings. There are two broods.

H. A. GOSSARD,
Wooster, Ohio.

WILT BUG.—See *Apple Wilt Bug*, this section.

WOOLLY APHIS.—See *Aphids*.

A Japanese Formula for Destroying the Woolly Aphis

Mr. T. Machida of Japan has recently found a very satisfactory wash formula which has been found to be of much value in the control of the woolly apple aphis. His recommendations for the various ingredients to be used are as follows:

Rape-seed oil	3 1/3 pints
Sulphur	1 1/2 ounces
Turpentine	7 1/3 ounces

The rape seed oil should be boiled alone for a very short time followed by adding the turpentine slowly, stirring continually until they are thoroughly mixed. Stir in the required amount of well crushed sulphur. Use a strong fire and allow to cool, when the mixture assumes a darkish color. Paint the attacked parts of fruit trees. This wash can also be recommended for use in the control of other aphids and the destruction of their eggs.

S. NAKAYAMA,
Stanford University.

California Com Hort., III, No 2.

Yellow-Necked Datana

D. ministra

Often conspicuous and quite injurious in September. Most of the caterpillars are well grown before the middle of the month and are ravenous feeders upon apple and other orchard and forest trees. The full-grown caterpillar is about two inches long with a black head and a yellow neck. A black stripe extends down the middle of the back and three stripes of the same color, alternating with four yellow strips, extend along each side. The body is quite hairy. The caterpillars are gregarious and collect together in large numbers out towards the ends of the twigs. If the branch is jarred or the caterpillars are in any way disturbed, they cling for support with their four middle pairs of legs, and elevate both ends of their bodies in the air at right angles to their support. Some time in September, they all descend to the earth and burrow beneath the surface from two to four inches, where they pupate. When the colonies are young, they are confined to a single small branch, which may be cut off and burned. After they become more mature, resort to hand-picking or spray the trees on which they are feeding, if not carrying fruit, with arsenate of lead, 5 pounds in 50 gallons of water. Kerosene emulsion may be diluted with 12 to 15 parts of water and sprayed directly on them. Make oil sprayings only on dry, sunshiny days so as to avoid all danger of injury to the foliage. The raincrows or cuckoos feed quite freely on these hairy

caterpillars, which are shunned by most birds.

H. A. GOSSARD,
Wooster, Ohio.

Apricot

The apricot is related to the peach, plum, almond, nectarine, cherry and prune. It is generally believed to have been a cross between the peach and the plum; but this has been disputed on the ground that it grows wild in Africa and the Caucasus mountains. In some parts of the Caucasus mountains the hills and mountainsides are covered with apricot trees, and in China also it grew wild at an early date. Its origin is, therefore, involved in mystery, and perhaps with our present information, cannot be definitely settled.

In growth, habit and the soil to which it is adapted, it is much like the peach; matures its fruit about the same time; the tree is not quite so tall; blooms a few days earlier, and is a little more likely to be killed by frost. In shape and color it resembles the peach; but in texture and the smoothness of its skin, it is more like the prune and plum. The bark of the tree is similar to that of certain varieties of cherry; its leaves are heart-shaped, bright green and yellow. It requires about the same kind of soil and cultivation as the peach, which see.

The apricot is regarded as a tenderer fruit than the peach, but this is doubtless due to the fact that it blooms earlier. It is not so profitable commercially. For this reason growers have not made such efforts to produce late blooming varieties. The peach is larger, has more varieties of flavor, therefore brings a better price in the markets, yet apricots are appreciated for canning purposes.

California produces more apricots than any other state in the Union. The apricot was introduced into California, by the Mission Fathers, where it was found in the Santa Clara valley in 1792. The varieties found there were not of high grade, generally seedlings, and much inferior to those introduced later by gold seekers from England and France in 1850 to 1860.

The Soil Best Adapted

The apricot will stand more humus, or a stronger soil than the peach. In the article on the peach it has been observed that this fruit will not endure a soil very rich in barnyard manure or other fertilizers. In the growing of cover crops in the orchards, it has been discovered that the peach is injured by a quantity of nitrogen and humus, that will give health and vigor to apples and pears. The apricot will stand more of these fertilizers than the peach, but like the peach, it requires a light dry soil, and a mixture of sand and gravel is beneficial.

The root system is not particularly strong, therefore, the soil should be loose and deep enough so that the roots will penetrate it without the energy necessary to break it up. It requires less water than apples and pears, and, therefore, the water should not be allowed to stand on the ground, or the soil to water-log. What we have said applies mostly to the improved varieties, rather than to the seedlings which grow with great vigor, and have great resisting power. These seedlings have sometimes a fruit of fine flavor, but very small as compared with the Moorpark or other improved varieties. In this, the apricot follows a general rule, for it is true of peaches, apples and other fruits that the trees which are the most hardy and resistant to injuries generally produce the poorest fruits.

Apricot trees are produced by budding on peach or apricot seedlings during the first summer's growth in the nursery row. These seedlings are produced either from peach or apricot seeds, planted during the preceding winter. As to the method of planting, see article on the peach. The tree is a vigorous grower, and must be carefully pruned to shape the top and to prevent the dwarfing of the fruit by an extra heavy crop. This method of pruning will also lessen the work of hand thinning. However, where the fruit is so close that the apricots crowd each other, hand thinning is necessary to the production of the largest and most profitable commercial grades. It is better to have a certain quantity, say 100 pounds or four

boxes, of large, well-developed and well-formed fruits, than to have the same number of pounds or boxes of small fruits, some of them malformed because of crowding.

Varieties

The best variety grown in the Northwest is the Moorpark. In all the Pacific coast states, as California, Oregon and Washington, the Moorpark takes the first place and brings to the growers the most money in proportion to the labor and expense of growing. It is a vigorous grower, begins to bear at the age of two years, is large, well-flavored and much in demand.

Apricots are used mostly for canning and for drying. For special information on these subjects, see articles on Canning and Evaporating.

GRANVILLE LOWTHER

Propagation of Apricots

The apricot is like the apple, in that it will not come true from the seed, and therefore must be propagated by budding or grafting, the former being almost exclusively employed. For the best results, seeds should be stratified in sand and frozen during the winter, as described for apples. Apricot seed, however, being larger and more able to meet adverse conditions than the apple, are sometimes planted in the fall in well-prepared ground. Here they freeze and come up without delay in the spring. If stratified for freezing (see *Apple*), they should be planted in early spring before they have begun to sprout. The young seedlings are to be given good culture during the summer, but are not to be dug up in the fall like apple seedlings. If they are to

be budded, the work should be done about the first of September, during the first season's growth. If it is desired to graft them, the seedlings should be cleft-grafted near the ground in early spring, at the beginning of the second season's growth, under conditions already described for the apple. If buds fail to take in the fall, the stock may be grafted the following spring. One year's growth, after being either budded or grafted, should make sufficiently large plants for setting them in the orchard. For details of budding, see discussion under the peach.

The apricot is often budded upon the peach, as the latter thrives upon a greater variety of soils than the apricot. The common plum makes an excellent stock for the apricot where it is grown in wet situations.

W. L. HOWARD

Varieties of Apricots and Synonyms

Acme, *Chinese*, *Shense*; Alexander, *Russian No. 2*; Blenheim, *Shipless*; Berda, *Annas*, *DeHollande*; Cluster; Early Golden, *Dubois*; Harris, *Harry Hardy*; Hem's Kirke; Large Early, *Gos Precoce*; Moorpark, *De'Nancy*; Newcastle, *Newcastle Early*; Orange, *Early Orange*; Peach, *Peach Royal*; Russian; St. Ambrose; Sheridan; Surprise; Tilton.

The very early varieties are the Harris, Hem's Kirke and Royal.

The early varieties are the Acme, Early Golden, Large Early and Peach.

The Moorpark is one of the best varieties for the Northwest and is medium early.

GRANVILLE LOWTHER

DATES FOR PICKING IN VARIOUS PARTS OF YAKIMA VALLEY, WASH.

VARIETY	TIME PICKED IN EACH DISTRICT AS SHOWN BY THE FOLLOWING						SIZE	COLOR
	White Bluffs Hanford and Kennewick	Parker and Donald	No. Yakima	Buenna, Zillah Granger, Sunny-side, Donald Grand, Prosser	Selah Naches			
Moorpark.....	7-17 to 7-27	7-26	7-24 to 8-16	7-19 to 8-12	8-10 to 8-18	Very Large.....	Yellow Blushed	
Royal.....	7-17	7-15	7-15 to 8-3	Large.....	Dull Yellow, Mottled with Brown	
Russian.....	7-17 to 8-2	Small.....	Yellow	
Tilton.....	7-17	7-24 to 7-30	Large.....	Yellow	
Yakimine.....	7-10 to 7-26	7-12 to 7-20	Very Large.....	Greenish Yellow, nearly covered with Brown	
Nectarines.....	8-14	8-14 to 9-12	8-28	

APRICOT DISEASES**Brown Rot***Sclerotinia fructigena*

A decay of the fruit while still on the tree, occurring some seasons in moist localities. The young growth as well as the fruit is also sometimes affected, the new shoots wilting and dying back from the attacks of this fungus. This is the most serious obstacle to stone fruit production in the Eastern states, but does not find sufficient moisture for its development in the arid West, except on early varieties in occasional seasons of late rains in the moister localities.

Spraying with self-boiled lime-sulphur just as the fruit is setting and again with the same following subsequent rains is recommended for trial.

RALPH E. SMITH,
Berkeley, Cal.

Bud Blight

Characterized by a dying of the buds during the early winter and caused very largely by the fungus responsible for Peach Blight.

Similar trouble is caused more or less by "Sour Sap" conditions.

See BLIGHT under *Peach*.

Fruit Drop

The fruit falls to the ground while still very small. Partly due to weather conditions and partly to lack of cross pollination, which can be secured by mixing varieties in planting. Seasonal conditions such as heavy rains at blossoming time or frosts may have this effect. The cherry, almond, peach and pear are affected in the same way.

The drop may not occur until the fruit reaches some size.

See general article on SETTING AND DROPPING OF FRUITS under *Fruits*.

FRUIT SPOT. See *Blight* under *Peach*.

GUMMOSIS. See *Cherry*.

Scab*Cladosporium carpophilum*

Same as Peach Scab, which see.

Blossom Rot*Sclerotinia*

The young fruit decays while still very small and enclosed by the calyx or outer cup of the blossom. The trouble occurs

when wet rainy weather prevails during the time of fruit setting. It commences in a rotting of the calyx cup, which is dead and susceptible to decay by saprophytic fungi, which decay spreads to the young fruit. It is caused by various fungi, of which perhaps a species of *Sclerotinia*, apparently *S. libertiana*, is most common, causing a decay of the young fruit on the tree. When such fruit is picked and placed in moist chamber it develops an abundant cottony mold in which black sclerotia soon forms. This appears to be the same fungus causing the cottony mold or white rot of the lemon storage. *Botrytis vulgaris* is also common in this trouble. Same treatment as brown rot.

Spraying for shot hole fungus might also be of some benefit in this trouble.

Shot Hole and Fruit Spot*Coryneum beijerinckii*

This fungus is the same as that causing the peach blight and produces in the apricot a spotting of the fruit, shot hole effect in the leaves and killing of the buds.

Spray with Bordeaux mixture during November and again in spring just as the buds open.

See *Blight* under *Peach*.

Sour Sap and Seasonal Effects

The apricot is particularly sensitive to sour sap and other seasonal effects. It is a tree having a free flow of sap, quick to respond to stimulating influences and one having the characteristic of all the stone fruits of forming an abundance of gum when injured in any manner. On this account, if any active movement from the roots is started early in the season by warm weather or an abundance of moisture and this activity be checked again by less stimulating weather conditions, trouble is very apt to follow. The sap becomes stagnant in the tissues, full of sugars and other easily fermentable substances, gum begins to form, sunburn may also occur and very often severe injury takes place in the tissues of the sap wood and cambium layer.

RALPH E. SMITH,
Berkeley, Cal.

APRICOT PESTS

The apricot is not the particular host of a large number of insects. In general its enemies are those common to other fruit trees of the same family.

Black Scale

Saissetia oleae Bern.

General Appearance

Black, oval, tough-skinned scales with a distinct "H" on the back of half and full grown females. From one-eighth to one-fourth of an inch in diameter. The



Fig. 1. Full Grown Specimens of Black Scale, *Saissetia oleae* (Bern.), at base of nightshade plant. Many of these were under the surface of the soil. (Essig, P. C. Jr. Ent.)

young vary from light yellow to brown. The males are very minute and scarcely ever seen. The eggs are nearly globular and slightly amber in color.

Life History

The females deposit from 50 to 300 eggs, covering a period of from two to four weeks. The most are laid during the months of May, June and first half of July, though in some sections all stages of the insect may be found. Young half-grown scales are most abundant from September 15th to December 15th and the

full-grown females from February 15th to July 15th. They work principally upon the leaves of the trees, when they are young, but later are found almost wholly on the limbs.

Food Plants

All citrus trees, olive, apricot, guava, honey locust, Irish juniper, pomegranate, Lombardy poplar, apple, prune, plum, almond, pear, sycamore, oleander, pepper (*Schinus molle*), sumach, (*Rhus*), mountain holly or Christmas berry (*Heteromeles arbutifolia*), *Baccharis viminea*, rubber tree, *Habrothamnus*, *Myoporum*, *Melaleuca*, laurel, holly, beech, ash, buckthorn, maple, *Grevillea*, *Ligustrum*, nightshade, *Antidesma*, *Duranta*, *Grewia*, *Thespesia*, *Cajanus*, magnolia, eucalyptus, grape, camellia, phlox, watermelon and asters.

Control

Fumigation: On citrus trees fumigate with from one-half to three-fourths schedule No. 1, between September 1st and January 1st. If the hatch is very even and the work can be done early, the one-half schedule is sufficient, but for ordinary work three-fourths of the schedule is required.

Sprays: On deciduous fruit and olive trees the following sprays may be used when the scales are not more than half grown: Water distillate caustic soda mechanical mixture and distillate emulsion.

Natural Enemies

The ladybird beetles, *Rhizobius ventralis*, steel blue (*Orcus chalybeus*), *Olla plagiata* and *Axion plagiatus* work on the young scales; the parasites, *Scutellista cyanea* and *Tomocera californica* Haw., on the eggs and the internal parasite, *Aphycus flavus* How., on the male scale.

E. O. ESSIG

Common Termite

Termes lucifugus Rossi.

General Appearance

The workers of this species are rather small, being shown as natural size in Fig. 1. They are transparently white in color, the contents of the alimentary canal giv-



Fig. 1. *Termes lucifugus* Rossi. Working on Roots of Nectarine Tree. (Original.)

ing a yellowish or brownish cast. The head is darker yellow and mandibles brown. The soldier ants have large brown heads, comprising at least one-third of their entire bodies. The queen ant is much larger than the other forms, while the males are small. It is claimed that there are no less than 15 kinds of individuals in this species.

Life History

These termites usually live in dead or decaying wood but often work into the living and growing tissues. They make very extensive galleries through all parts and thus often destroy buildings, fences, etc., as well as fruit trees. The queen gives rise to all the young, which appear in great numbers, especially during the summer months. In the fall or autumn winged or migratory forms appear and often fly by thousands on dark days and towards evening. In habits and life history they greatly resemble true ants and bees.

Distribution

General.

Food Plants

As previously stated, these termites usually work upon dead or decaying wood, but then usually only in the presence of moisture. These insects often become destructive to fruit trees, working upon the roots underground and making galleries up the trunk. No doubt they usually begin to work in the decaying tissues but often continue into the

healthy portions of the tree. Nectarines, peaches and apricots seem to suffer most, while citrus and other trees and plants are also attacked.

Control

Due to their secluded work the damage is usually done before their presence is known and too late to effect a remedy. However, if close observations are made in infested districts and their work discovered the colony may be almost entirely exterminated by the use of a liberal dose of carbon bisulfid applied in cotton or a sponge directly within their burrows or under the base of the tree.

E. O. ESSIG

BROWN APRICOT SCALE (*Eulecanium armeniacum* Craw.) (*Lecanium corni* Bouche). See *European Fruit Scale* under *Apple*.

CANKER WORMS. See under *Apple*.

EUROPEAN FRUIT SCALE. See under *Apple*.



Fig. 1. Immature Specimens of the Frosted Scale on Loganberry Cane. (Original.)

Frosted Scale*Eulecanium prunosum* Coq.**General Appearance**

This is one of the largest unarmored scales, often one-half inch in length and three-fourths inch wide. The full grown scales are nearly hemispherical in shape, while the young and half-grown forms are very flat. (Fig. 1, p. 551.) The surface is covered with white frost-like wax, which readily distinguishes it from all other common species.

Life History

Eggs are white to yellowish in color and are deposited in the early summer months. The species is not as prolific as many of the others of this genus, and because of parasites scarcely does any damage.

Distribution

Throughout the central and southern parts of California.

Food Plants

Apricot, prune, peach, plum, cherry, pear, apple, walnut, laurel, ash, birch, sycamore, cork-elm, grape, rose, orange, loganberry and hawthorn. The branches are usually the parts attacked.

Control

Same as for European fruit scale (*Leucanium corni*). See *Apple*.

Natural Enemies

Comys fusca and at least two other internal parasites were bred from this species, and keep it in complete subjection.

E. O. ESSIG

MEALY PLUM LOUSE. See under *Plum*.

PEACH BORER. See under *Peach*.

PEAR THRIPS. See under *Pear*.

PLUM CURCULIO. See *Curculio* under *Apple*.

SHOT HOLE BORER. See under *Cherry*.

TERMITE. See *Common Termite*, this section.

WHITE PEACH SCALE. See under *Peach*.

Arkansas

Arkansas has a good soil, a humid climate, and many natural sources of wealth. It is adapted to the growing of nearly all the varieties of fruits generally grown in the temperate climates, such as apples, peaches, pears, strawberries, grapes and small fruits, all of which, with proper care, bring profitable returns.

The mean elevation is 650 feet. The eastern part, for 30 to 100 miles west of the Mississippi river, is generally low and subject to inundations from numerous overflowing bayous, lakes and swamps, caused by the overflow of the Mississippi river. In this region there are a few high places, rising generally toward the table land and the high hills of the west. In the northwest part are the Ozark and Boston mountains, which, while they do not reach the height of mountains, yet are rugged, picturesque and, as compared with the country about them, are of sufficient height to justify the name. These hills or mountains continue westward into Oklahoma and northward into Missouri. Here Arkansas grows its best apples, peaches and strawberries, and these fruits have made the state famous. Nature has done much for Arkansas; but the fruit growers are not as a rule making the most of their natural advantages; for they incline to plant the trees and, without much care or the application of modern methods, permit Nature to do the rest.

The state is divided, geologically, into two parts by a line drawn from Texarkana in the southwest corner, to Miller county, running northeasterly through Little Rock, to Pawhatan in Lawrence county in the northeast. The northwestern division is hilly and underlaid with heavy paleozoic rocks, and the southeast corner with cretaceous rocks. The southeastern part is mostly alluvial soil, some of it requiring drainage, and is very fertile, therefore adapted to the growing of vegetables, strawberries and other small fruits; but cotton, corn, wheat, oats, rye, hay, potatoes and tobacco are the main crops. For further information see Ozarks.

GRANVILLE LOWTHER

Frost and Precipitation

Station	Frost				Precipitation
	Average Date of		Date of		Annual Inches
	1st Killing in Autumn	Last in Spring	Earliest in Autumn	Latest in Spring	
Fayetteville	Oct. 19	April 10	Sept. 29	April 30	44 3
Dodd City	Oct. 18	April 13	Sept. 29	May 1	47.2
Pocahontas	Oct. 23	April 3	Oct. 8	May 2	43 5
Fort Smith	Nov. 4	Mar. 24	Oct. 15	April 6	41.8
Conway	Oct. 27	Mar. 23	Oct. 2	April 12	45.4
Little Rock	Nov. 9	Mar. 21	Oct. 22	April 14	49.6
Helena	Nov. 1	Mar. 25	Oct. 21	April 6	55.2
Dallas	Nov. 4	April 4	Oct. 7	May 1	51.0
Pine Bluff	Nov. 6	Mar. 27	Oct. 19	April 19	48 8
Camden	Nov. 7	Mar. 24	Oct. 8	April 12	49 2
Warren	Nov. 4	Mar. 30	Oct. 10	April 8	49 0

Arizona

Arizona has an area of 113,020 square miles. In the northern part, the state is a dry plateau, arid and of little value without irrigation. In the south it is mountainous, the valleys are broad, sometimes 20 to 30 miles in width. The principal mountain masses are Castle Dome, Big Horn, Eagle Tail, Chocolate Dome Rock, Palomas Harquahala, San Francisco and Black in the north central; Carrizo, Lukakukia and Tunica in the northeast; Zuna, White Mogollon and Catalena in the southeast and south. San Francisco mountain, above Flagstaff, is the highest, rising 12,794 feet above the sea. To the south the surface falls sharply to low ridges, mostly of volcanic origin, thence by terraced mesas down to the great desert plain little above sea level. This plain is cut by gullied stream beds in which the surface water from the occasional rainfall flows into the broad Gila valley. At Flagstaff the rainfall is 24.65 inches; at Yuma, 2.84 inches.

The sandy regions of the southwest are the hottest portions of the continent. It is common for the mercury to rise to 120 degrees Fahrenheit in the shade during July and August, but the atmosphere is so clear that, while the sun is scorching in its heat, it is said not to be oppressive, and the winter climate is excellent.

The drainage system is the Colorado river with its tributaries, the principal of which is the Gila.

There can be but little fruit grown in Arizona without irrigation. In the northern part of the state the Colorado river is the principal stream, but it runs in a deep canon, and at the present time there is no method provided that seems practical for diverting or lifting the water from this deep bed for the purposes of irrigation. The rivers of Arizona draw moisture from the mountains, but these mountains are not covered with snow during July and August, the season when the moisture is most needed for irrigating purposes. The habit of flooding the land several times during the season when the snows are melting in the mountains, then cultivating intensively during the dry season, forming a dust mulch to conserve the moisture, has been successful for the growing of certain kinds of fruits and vegetables. This system is practiced largely in many sections of the state.

The Temperature

One of the principal difficulties in growing fruit in Arizona is the extreme heat. The sun is so hot, and the air so dry, that the evaporation is very rapid, and even where there is plenty of water in the earth, the plant often fails to take it up as fast as the sun evaporates it from

the leaf, and the plant withers. In order to obviate this in the growing of apples, peaches and other fruits of this character, the stem is headed very low, so that it may be shaded and the bark not be injured by the sun. Further, there is a more rapid supply of moisture where trees are headed near the ground than where they lift the water to a greater height. At Tuscon, the evaporation is said to be 78 inches per annum; which makes an abundant supply of water necessary for the growth of fruits.

The varieties of fruits best adapted to such a climate are those with thick leaves, small evaporating surface, or with few pores that admit of rapid transpiration.

From the survey of the Salt River valley, made by Thomas H. Means, we quote as follows:

Fruit Farming

"Figs are grown, but the cost of labor in handling them and the freight rates, make the industry a financial failure. The growing of stone fruits is another industry held down by the cost of labor and freight rates. Excellent fruits of this kind are grown, but the trade is largely within the state. Almonds, when they escape the late frosts, and olives, which are weighty in proportion to their value, may prove a success financially.

"Grapes are grown successfully, and the warm dry climate is eminently suited to the growing of raisins and wine grapes.

Oranges

"The orange industry of the Salt River valley is as yet in its infancy. Only a few orchards of any size are in bearing, but the success obtained by these has started a rapid development, and orange groves are rapidly being set out. The district considered most favorable for oranges lies along the base of Camelback mountain and the Phoenix mountains. Here the frost is least and the daily range of temperature the smallest. No complete losses have ever been experienced from frost, for the fruit ripens early and is off the trees before the frost comes, yet on two occasions the trees have been damaged.

"One great advantage which orange groves here have over Southern California orange groves is the date of ripening. Arizona oranges ripen in time for the Thanksgiving market and for this reason have the advantage of high prices. The larger part of the fruit is marketed by Christmas.

"The orange belt is no doubt capable of extension over a much larger area than is at present supposed to be orange territory. Great care should be given to the selection of orange lands, for there are certain areas not suited to orange culture."

Fruits Best Adapted

It would not be possible to grow commercial fruits successfully in Arizona, without carefully studying the varieties best suited to the soil and climatic conditions. In some parts the soil is adobe, some is strong in alkali and other salts, and all of it is subject to a hot sun and rapid evaporation. What varieties to choose and how to treat them under the conditions, is the problem that confronts the fruit grower.

In the New Cyclopaedia of American Horticulture, J. W. Toumey gives a list of fruits and varieties that was collected as a result of 60 letters sent to the leading orchardists of the state. This list, with those recommended by the American Pomological Society* and the advice of the directors of the experiment station, will enable any one without experience to decide with considerable accuracy. The following is Mr. Toumey's list.

Almonds—Ne Plus Ultra, IXL.

Apples—Early Harvest, Early Strawberry, Red Astrachan.

Apricots, Early—Bennett's Early, Newcastle, Peach, Pringle.

Apricots, Late—Moorpark, Royal, St. Ambroise, Smith's Triumph.

Blackberries—Lawton's Early, Crandall's Early, Early Harvest.

Dewberries—May's.

Grapes—Thompson's Seedless, Sultana Seedless, Rose of Peru, Salem, Muscat, Rogers' No. 9.

* U. S. Department of Agriculture, Bureau of Plant Industry, Bulletin 151, "Fruits Recommended for Cultivation."

Grape Fruit—Triumph, Walter, Bowin
Lemons—Villa Franca, Sicily.
Mulberries—Downing, Russian.
Olives—Manzanillo, Nevadillo, Blanco,
Mission.

Oranges—Ruby Blood, Jaffa, Parson's
Brown, Mediterranean Sweet, Bahia
(Washington Naval).

Peaches, Early—Early Crawford, Par-
son's Early, Triumph, Sneed, Strawberry.

Peaches, Late—Globe, Salway, Oldmix-
on, Heath's Freestone, Muir, December
Cling.

Pears, Early—Brandywine, Bartlett,
Wilder.

Pears, Late—Winter Nelis, Pia Berry.
Plums—Wickson, Kelsey, Botan White,
Royal Native.

Pomegranates—Ruby, Sweet, Golden,
Papershell.

Quinces—Champion, Portugal, Orange.

Strawberries—Arizona Everbearing.

Arizona is still an undeveloped state,
and just what is possible has not yet been
determined, but it seems sure that when
experiments have proven the products
best adapted, and the best methods have
been employed, that it will be far more
productive than at present.

GRANVILLE LOWTHER

Frost and Precipitation

STATION	FROST				Precipita- tion
	Average Date of		Date of		Annual
	First Killing in Autumn	Latest Killing in Spring	Earliest Killing in Autumn	Latest Killing in Spring	Inches
Fort Defiance.	Sept 23	June 2	Sept. 11	June 7	12.8
Mohave...	Dec. 3	Feb. 23	Nov. 23	Mar. 24	5.4
Holebrook	Oct. 15	Mar. 8	Sept. 17	June 13	7.9
Signal	Nov. 15	Mar. 13	Oct. 30	April 8	7.1
Prescott	Oct. 20	Mar. 20	Sept. 15	June 2	15.6
Phoenix...	Dec. 3	Feb. 23	Nov. 9	Mar. 31	6.8
Fort Apache.	Oct. 13	May 10	Sept. 22	June 12	17.6
Yuma	2.7
Dudleyville	Nov. 13	Mar. 30	Oct. 16	May 3	12.0
Oracle...	Dec. 4	Mar. 29	Nov. 12	May 3	15.9
Fort Grant	Nov. 26	April 1	Nov. 2	June 4	13.5
Tuscon	Nov. 22	Mar. 26	Oct. 16	May 3	9.8
Fort Huachuca.	Nov. 28	April 5	Oct. 30	May 3	16.2

Artichoke

The artichoke is a thistle-like plant of the aster family, probably a native of Southern Europe, but now widely cultivated. The fleshy bases of the scales on its globular head, together with the receptacle, are edible while immature. The Jerusalem artichoke is cultivated for its edible tubers. W. R. Beattie says:

Artichoke, Globe

"Deep, rich sandy loam, with a liberal supply of well-rotted manure, is best suited for growing artichokes. Plant the seeds as soon as the soil is warm in the

spring, and when the plants have formed three or four leaves they may be transplanted to rows three feet apart and two feet apart in the row. The plants do not produce until the second season, and in cold localities some form of covering will be necessary during the winter. This crop is not suited for cultivation north of the line of zero temperature.

"After the bed is once established the plants may be reset each year by using the side shoots from the base of the old plants. If not reset the bed will continue to produce for several years, but the burs will not be so large as from new plants.

The bur, or flower bud, is the part used, and the burs should be gathered before the blossom part appears. If they are removed and no seed is allowed to form, the plants will continue to produce until the end of the season.

"The heads, or burs, of the French artichoke are prepared for the table by boiling, and served with melted butter or with cream dressing.

Artichoke, Jerusalem

"The Jerusalem artichoke will grow in any good garden soil, and should be planted three to four feet apart each way, with three or four small tubers in a hill. If large tubers are used for planting they should be cut the same as Irish potatoes. Plant as soon as the ground becomes warm in the spring and cultivate as for corn. A pint of tubers cut to eyes will plant about 30 hills. The tubers will be ready for use in October, but may remain in the ground and be dug at any time during the winter.

"The tubers are prepared by boiling until soft, and are served with butter or creamed. They are also used for salads and pickles.

"The Jerusalem artichoke is not of great importance as a garden vegetable, and the plant has a tendency to become a weed."

ASHES. WOOD. See *Apple Orchard, Fertilization of.*

Asparagus

Asparagus belongs to a genus of plant containing more than 100 species. It was introduced into America from Europe and has become in this country an important article of food. Several of the climbing species are grown in greenhouses for their delicate feathery branches and are valuable for cuttings and decorations.

The young shoots of the species *Asparagus officinalis* have from very early times been much prized for food, owing to their pleasant flavor and slightly laxative properties. This species is a native of the north temperate zone of the old world, and grows wild on the south coast of England. On the waste steppes of Russia it is so abundant that it is eaten by cattle like grass.

In some sections of the country, asparagus is grown largely for the markets. It is also grown in very many private gardens for home use. It is very hardy, is a vigorous grower, and heavy feeder; therefore will succeed best on a very rich soil. It can be grown in sections strong in mineral salts, such as alkali, or in deep alluvial and peaty soils. Where the native soil is not adapted, it can be made adaptable by the digging of trenches, and filling in with barnyard manure, sand (where the soil is a heavy clay), muck, rotten leaves or other fertilizers. For commercial purposes, asparagus is planted in rows, about the width of corn rows, three to four feet apart, and the roots are planted in hills about the same distance apart, or sometimes not more than two feet apart. Some growers plant so that the stalks will row both ways, and the ground can be cultivated both lengthwise and across the field. For home use, however, it requires but few stalks and it is generally planted in trenches, or in beds.

Propagation from Seeds

Seeds should be sown in rows three to four feet apart, so as to admit of cultivation. The seeds should be planted two to four inches apart in the rows, and kept free from weeds. The time of planting is about that of any other spring crop, but may be earlier, because asparagus is not easily injured by spring frosts. These are termed nursery plants, and may be removed the following autumn or spring, and set in permanent beds, or rows, as the case may be.

Transplanting

Not all the plants grown should be transplanted to the field or bed. There is great variety of tenderness or toughness in the plants, and only the tender plants are good for food or for market. The tender plants lengthen rapidly, produce a straight succulent needle-like stem, and do not branch near the ground; while the tough plants lengthen more slowly and tend to branch near the ground. Further, the tender plants are usually straight-grained smooth and blunt at the tips. When the plants are but few

inches in height it is easy to tell the difference between the tender and tough varieties. The smaller seedlings with a tendency to show woody fibre or a tough gnarled appearance should be weeded out.



Fig. 1. Asparagus Crown, Roots, Buds and Spear. (Redrawn and reduced, from plate 113 of Thome's Flora von Deutschland.)
—Farmers Bulletin 61

Propagation from Roots

An asparagus plant has a very broad spreading crown, with a good many buds. Any plant which shows unusual merit in the spring when it starts into growth may have this crown divided. Often a half dozen plants may be started from the same crown. It is better to dig up the entire root, or as nearly so as it is convenient to handle; then divide the plant

into sections at the joints, so that each piece possesses a few buds and some roots attached. These roots may be planted as individual plants, and when they become established will produce the same as the parent plant from which they were separated.

The roots may be set in autumn or early spring, in deep rich soil, and generally the crown should be covered from four to six inches. In a light mellow soil the depth of setting may be greater than in a heavy compact soil. They should be well cultivated, especially for the first year or two, but after they are fully established they are such vigorous growers that they are generally neglected; but even then, good cultivation pays, for it produces a larger number of vigorous, succulent young stalks for the market.

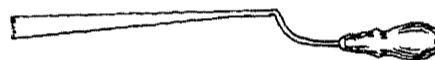

Fig. 2. Knife for Cutting Asparagus.

Cutting Asparagus

It is never best to cut plants for the table or for market until the roots have been planted two years, or, in poor soils, three years. After the age for cutting, all sprouts should be kept cut, whether they are big enough for the market or not. If the smaller stems are allowed to appear, the plant ceases to produce more sprouts. Ordinarily one may continue to cut for the market as long as the sprouts are succulent and desirable. In cutting, care should be taken not to injure the root, but cut as close to the root as possible without injury. When preparing for the markets, the sprouts should be washed in clean water, bunched and tied in neat small bundles.

Varieties

Among the best varieties are Conover's Colossal, which has very large stems, starts early in the spring and has a pronounced flavor. The Palmetto and Mammoth are sweeter, have a less pronounced flavor, and are preferred by many persons. Late in the autumn the tops should be mowed close to the ground and the field given a heavy coating of manure.

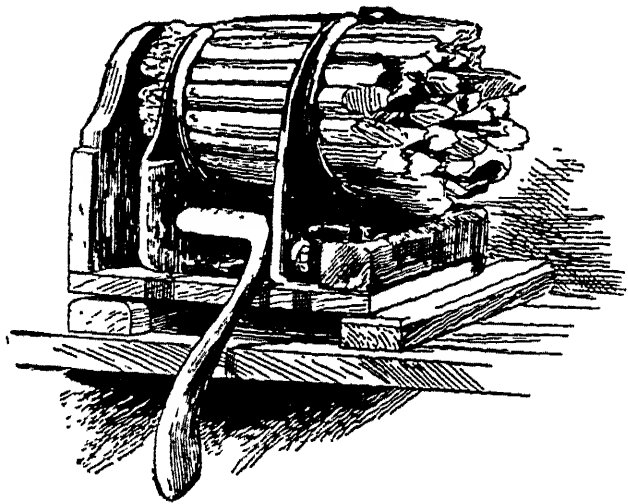

Fig. 3. Asparagus Buncher and Bunch of Spears Ready to Be Tied.
—*Farmers Bulletin 61.*

Cost of an Asparagus Bed

The cost of establishing and maintaining an asparagus bed is so dependent upon the value of land, the cost of labor, the kind and amount of manure used, and the method of securing plants, etc., that no definite figures can be given, but can be best estimated by the farmer himself, remembering that it is only once in 15 or 20 years that this has to be met.

A prominent and successful New Jersey grower says:

"I cannot give the cost in detail of establishing asparagus beds, as so much would depend upon whether one had roots to buy, and upon other matters. Where growers usually grow roots for their own planting the cost is principally the labor, manure, and loss of use of land for two years, upon which, however, a half crop can be had.

"The cost of maintaining a bed I can only estimate, as at times all the men on the farm may be at work at the asparagus, and at other times none at all, and I do not keep an account of the time put in at the asparagus. I should estimate the cost per acre as follows:

Manure (applied in the spring).....	\$ 25
Fertilizer (applied after cutting).....	15
Labor, plowing, cultivation, hoeing, etc.	20
Cutting and bunching.....	40
Total	\$100

"A bed well established, say five years after planting, when well cared for should for the next 10 or 15 years yield from 1,800 to 2,000 bunches per annum, or at 10 cents per bunch (factory price), \$180 or \$200."

This agrees very closely with the actual figures of the yield and receipts of another New Jersey grower who in 1896 cut 22,584 bunches from 12 acres, all of which were not in full bearing, or 1,882 bunches per acre, and received \$2,611 net returns from commission houses, or a fraction over 11 cents per bunch. Of course those getting higher prices or larger yields will exceed this, but it is a fair average for those who sell on commission or to canneries.

The cost of good one-year-old plants ought not to be over \$4 per thousand, and it requires from 1,800 to 3,600 to fill an acre, depending upon the distance between plants; perhaps 2,500 would be a fair number, allowing surplus plants to fill missing hills, or \$10 per acre. The plants can be grown from the seed for half that sum, if that plan be preferred.

The cost of establishing a bed can be somewhat reduced by planting for the first two or three years some early garden crop between the rows, such as potatoes, peas, beets, onions, strawberries, etc., for as the roots are as yet not occupying all the ground there will be no injury to the plants, and the manure and cultivation necessary for the young asparagus will be sufficient for the other crop, hence the receipts for it will be almost entirely net, and yield at least the returns of "a half crop."

The estimate above calls for an annual expenditure of \$40 per acre for fertilizer and manure, which is a liberal allowance; another estimate requires 2,000 pounds per acre of a mixture containing 400 pounds of muriate of potash, 1,100 pounds acid phosphate, and 500 pounds of nitrate of soda, which at market prices can be secured for less than the above sum.

R. B. HANDY,
U. S. Dept of Agriculture.

Asparagus

(Adapted to Southern Conditions)

This is one of the best paying crops of the garden and can be grown anywhere in the temperate regions. Any land that will grow corn will grow asparagus but it is a crop that responds readily to inten-

sive culture. Asparagus is the first green vegetable of the spring and therefore is in great demand for home use and for market.

To prepare a permanent bed of asparagus the land should be heavily manured (at least 10 to 15 tons) and broken deeply in the fall. In early spring the land is replowed, disced both ways and thoroughly harrowed. This thorough preparation incorporates the manure with the soil

The best time to plant asparagus in the South is in late January or early in February but in the North plantings can be made as late as November, provided the land has been thoroughly prepared some time in advance so that the manure is well decomposed.

Only strong one-year-old plants should be used, though seed can be sown in the row and the plants can be thinned out to the desired distance. Plants can be secured from any reliable seed dealer.

The distance that the plants should be set varies with different growers but for most purposes the best plan is to plant five feet between the rows and place the plants three feet apart in the row.

The land at planting time should be checked off with the plow both ways, running one way twice to make a deep furrow. The plants are set in these checks allowing a space of from 6 to 8 inches between the top of the crown and the surface of the ground. The plants should not be entirely covered with soil at the time of planting; the upper three or four inches of space will be gradually filled in by the subsequent cultivation as the plant grows through the soil.

During the first season the land should be kept well cultivated to maintain a soil mulch and also keep down weeds. Cultivation should continue until the tops have matured.

When the berries on the plants have turned red the tops should be cut down and left in the field to dry thoroughly. On a windy day the patch can be burned over thus destroying the rubbish and troublesome insects. After the patch has

been burned over spread a coating of manure over it and allow this to remain as a mulch until spring.

Early in the spring of the second year the rough manure should be raked off and the ground should be worked. It is a good plan to plow turrows in both directions over the row thus leaving a ridge on the row and a dead furrow between the rows. After plowing use a spike toothed harrow or cultivator and level down the beds.

Cultivation should be given as outlined for the first season. Cut down the tops, burn over the patch and top dress with manure as before. An application of a high grade fertilizer in early summer will produce a good strong growth that forms a good root system.

The patch can be cut the third season but this cutting should be rather light. The bed should be worked as outlined for the previous seasons but early in the spring an application of from 75 to 100 pounds of nitrate of soda per acre should be made as a top dressing near the plants. This fertilizer is readily available and will give results in the crop to be cut. When cutting has ceased or about May 1st, the patch should receive an application of 1,000 pounds of fertilizer made up as follows:

Acid phosphate	400 lbs.
Nitrate of soda	100 lbs.
Cotton seed meal	350 lbs.
Muriate of potash	150 lbs.
Total	1,000 lbs.

The above is a 7-4-8 goods and it should be broadcasted and disced in running the disc across the rows. Cultivation should then be kept up as in previous years.

When cutting the asparagus select those stalks which are about 6 inches long and run the knife about 2 inches down under ground. Care must be taken in cutting not to injure the shoots which are just pushing up through the soil. Every stalk whether it is thin or fleshy should be cut at each cutting as this prevents insects from laying eggs on the old shoots that are left and it also conserves the strength of the plants. As soon as the asparagus stalks are cut

they should be carried to a shady place where they are sorted and packed in bunches. These bunches are made uniform by using wooden boxes open at the top and at one end and of the desired length. The stems are then cut to an even length with the asparagus knives and the bunch is tied with raffia. These bunches usually weigh about one pound. All small, tough, withered stalks should be discarded. To keep the bunches fresh for the local market the bunches should be set upright in pans containing about an inch of water. All cutting should be done bright and early in the morning before the dew is off the plants.

The bunches are packed in crates holding two dozen bunches and the bases of the bunches are set on a layer of damp moss. The crates are made of 4 slats $3\frac{1}{2} \times 22$ inches, 2 slats $6\frac{1}{2} \times 22$ inches and 2 pieces $6\frac{1}{2} \times 9$ inches, the latter for the heads.

If bleached grass is desired, hill up the rows and cut the stalks 5 inches below the surface.

If the plants are to be raised from seed a good sunny, well drained slope should be selected and the land should be prepared as for the permanent bed. Sow the seed in February and after the plants come up keep them well cultivated and fertilized. The plants are allowed to remain in the seed rows for one year and are then transplanted to the permanent bed. One ounce of seed will sow about 50 feet of drill and this will make about 200 plants.

It requires 2,900 plants for an acre, and if the plants are purchased they will cost \$5.00 to \$6.00 per 1,000, the cost for the acre being about \$15.00.

A good patch of asparagus that has been well cared for should last 25 years and a good average yield per season should be 150 crates. If asparagus is desired very early in the spring the site for the patch should be selected on a sandy southern slope.

Varieties to be recommended are Palmetto, Conover's Colossal and Argenteuil.

W. P. WILLIAMS

ASPARAGUS DISEASES

Anthracnose

Colletotrichum sp

Is said to have appeared in New Jersey and Ohio, but seems not to have spread destructively. It appears as small specks upon the stem.

Rust

Puccinia asparagi

Causes premature death of the bushy tops which grow up after the cutting season, thus injuring the vitality of the plants. The fungus causing the rust shows three different stages, the spring rust, appearing in the form of elliptical patches on the stems of plants which are allowed to grow up early in the season, the summer or red rust, which covers the tops with a reddish, dusty powder of spores during the summer, causing their death, and the black rust stage, which appears on the tops in the form of numerous black pustules following the red rust.

During the cutting season allow no wild asparagus to grow up.

Keep the fields well irrigated and cultivated during the summer and fall after cutting stops. Dust the tops thoroughly with flowers of sulphur about three weeks after the cutting season ends and repeat this two or three times during the remainder of the season.

Select seed for planting from the most rust-resistant plants.

RALPH E. SMITH
Berkeley, Cal.

(The Palmetto variety is said to be more rust resistant than others.—Ed)

Damping Off, Rhizoctonia, Root Rot Fungus, Stem Rot Fungus

Corticium vagum B. & C.

This fungus attacks a variety of garden plants and causes a wet rot at the surface of the ground.

The disease is difficult of control as it seems to live indefinitely in the soil.

General sanitary measures, good surface drainage and lime on acid soils is suggested.

Tendency to Variation

We give herewith an illustration of an asparagus stem, which represents the



Fig. 1. Asparagus Stalk Four Feet Long, Four Inches Wide and One Inch Thick.

tendency under certain conditions, to vary from the normal. The stalk which this figure represents was about four feet long, four inches wide, and one inch thick.

ASPARAGUS PESTS

Asparagus Miner

Agromyza simplex Loew

General Appearance

The adult flies have a wing expanse of about one-sixth of an inch and are metallic-black in color. The maggots are one-fifth of an inch long and white. The puparia are one-seventh of an inch long and red.

Life History

The first adult insects appear early in the spring, other broods appearing later. The larvae mine beneath the epidermis of the stalks near the bases and may penetrate eight inches underground. The injury is often so severe as to completely girdle the stems and thus do much damage. The puparia are formed in the burrows, especially on the roots and bases of the stalks. There are at least two generations each year.

Distribution

This fly has been reported from New England to Tennessee and in California.

Food Plant

This pest works only upon asparagus plants.

Control

The control of the fly is somewhat difficult and consists in the use of trap crops early in the spring, which should

be removed, roots and all, and burned in June. Other traps should be allowed to grow up immediately and similarly destroyed in the fall.

Cutting out all infested stalks as often as they appear is also advisable.

E. O. ESSIG

Common Asparagus Beetle

Crioceris asparagi Linn.

General Appearance

The adult beetles are slightly less than one-fourth of an inch in length and very slender. The color is metallic bluish-black with red thorax marked with black dots. The reddish-yellow or cream colored wing covers are marked with black. The eggs are elongate, about one-tenth of an inch long, dark brown or black and stuck to the shoots by one end. The larvae are shiny olive gray with black head and legs. The pupal stage is passed in the ground in a thin cocoon, the pupae being yellowish in color.

Life History

The adults hibernate during the winter under any protective covering and appear in the spring about the time the young asparagus shoots are coming through the ground. The adults immediately begin to feed upon the tender sprouts and to lay their eggs upon them. The eggs hatch in about a week and the grubs begin to feed upon the sprouts. The broods continue to work throughout the summer eating all parts of the asparagus plants. After about two weeks the larvae are ready to pupate. They then leave the plant and work into the soil where pupation takes place and within eight or nine days they emerge as adults. The entire life cycle requires one month but there are many overlapping generations each year.

Distribution

New England, south and west to the Mississippi, and in California.

Food Plant

So far as known, the pest feeds only upon asparagus, attacking principally the tender shoots but also working upon the rind and stems of the older seed plants.

Control

The control of this pest is not so difficult as it would seem in view of the fact that arsenical sprays cannot be used upon the tender marketable shoots because of the poisonous effects to the consumers.

In the spring when harvesting the shoots it is advisable to leave some of them for the beetles to lay their eggs upon; cutting and burning these before the eggs hatch. Another practice is to keep all the seedlings except a few for traps, cut down. Upon those left the beetles will collect in great numbers and may be easily killed. In the spring or after they are covered with eggs the plants should be cut down and burned.

As soon as the crop is harvested the seedlings and feathery plants should be thoroughly sprayed with arsenical sprays, which will serve to kill many of the mature beetles before they go into winter quarters. One pound of lead arsenate to sixteen gallons of water has given excellent results.

Dusting air-slacked lime of pyrethrum upon the larvae or spraying plants infested by them with kerosene emulsion or tobacco extract are exceedingly effective as the larvae are very delicate. Brushing to the ground also destroys large numbers of them. Burning the rubbish in the winter destroys many of the hibernating beetles.

Natural Enemies

The young of the ladybird beetles, *Megilla maculata* and *Hippodamia convergens*, prey upon the young larvae. In the east the spined soldier-bug (*Podisus maculiventris* Say) and the bordered soldier-bug (*Stiretrus anchorago* Fab.) as well as certain other insects also feed upon the larvae.

E. O. ESSIG

Twelve-Spotted Asparagus Beetle

Crioceris 12-punctata L.

Description

A trifle larger and stouter than the common species, uniformly reddish in color, with 12 black spots on the wing covers. Eggs are attached by their sides

instead of ends, usually on old plants instead of young shoots if such are available.

Character of Injury

Hibernated beetles feed on shoots in spring. Later beetles and larvae prefer the berries. Larvae seem to feed almost exclusively on the berries. Cut all plants down to the ground in early spring, and cut new shoots before eggs hatch. Allow some shoots scattered over the field to grow larger than others and most of the eggs will be deposited on these. When they are well covered with eggs cut and burn and allow other shoots to grow for same purpose. Spray with arsenate of lead late in the season when cutting period is over. Chickens and ducks will devour many if given the run of the garden.

H. A. GOSSARD,
Wooster, Ohio.

Australia

Orchards and Fruit Gardens

Fruit growing has made rapid progress in Australia during recent years, the area devoted thereto having increased in the past ten years by no less than 56,936 acres. The states in which the increase was most marked were: Tasmania, 17,900 acres; Victoria, 12,731 acres; Western Australia, 12,668 acres; and South Australia, 6,529 acres. During the same period the Queensland fruit-growing area increased 5,738 acres, while in New South Wales a slight increase of 1,310 acres was exhibited.

The varieties of fruit grown differ materially in various parts of the several states, and range between such fruits as the pineapple, paw-paw, mango, and guava of the tropics, and the strawberry, the raspberry, and the currant of the colder parts of the temperate zone. The principal varieties grown in Victoria are the apple, pear, peach, apricot, plum, and cherry. In New South Wales citrus fruits (orange, lemon, etc.) occupy the leading positions, although apples, pears, peaches, cherries, plums, and apricots are also extensively grown. In Queensland the bananas, oranges, pineapples, peaches, apples, mangoes, and plums are most large-

ly grown. In South Australia, in addition to the apple, pear, peach, apricot, plum, orange and lemon, the almond and the olive are also largely grown. In Western Australia, the apple, orange, peach, pear, plum and fig are the sorts chiefly grown, while in Tasmania, al-

though the apple represents four-fifths of the area in that state devoted to fruit growing, small fruits, such as the currant, raspberry, and gooseberry, are very extensively grown, and the balance of the area is mainly occupied with the pear, plum, apricot, peach and cherry.

Area Under Fruit in the Commonwealth, Year Ending March 31st, 1913

	N. S. W.	Victoria	Queensland	S. A.	W. A.	Tasmania	C'wealth
Fruits	49,389	63,209	18,556	29,905	19,540	30,575	205,174
Vines—Wine	8,103	24,579	1,428	25,208	3,010	62,388
Vines—Table	3,893	2,624	1,046	2,194	1,891	11,648
Market gardens	9,836	10,414	2,386	2,857	3,664	1,458	30,676
Melons	4,174	2,632	6,122	...	731	13,662
Hops	...	131	5	...	1,247	1,383
Acres	75,455	103,589	29,538	60,169	28,836	33,280	324,931

Value of Fruit (English Pounds) in the Commonwealth, Year Ending March 31, 1913

	N. S. W.	Victoria	Queensland	S. A.	W. A.	Tasmania	C'wealth
Fruits (not including vines)	532,472	880,657	365,177	393,433	210,531	384,877	3,067,147
Hops	...	10,421	...	100	...	104,031	114,552
Pumpkins, melons	74,805	25,000	61,758	...	5,751	...	167,354
Market gardens	369,069	286,385	64,265	106,736	121,874	12,295	962,535
	1,276,346	1,202,463	491,200	500,269	338,156	501,203	4,311,588

Raisins and Currants Dried 1912-1913

Victoria, 12,283,824 acres; New South Wales, 494,704 acres; South Australia, 3,947,776; Western Australia, 176,400 acres.

For the statistical year ending March 31, 1913, there were in the jam manufacturing business 133 factories working in the Commonwealth; total number of employees was 4,499; the wages paid amounted to £275,138. The total value of the output reached £1,884,045, and the amount of material used was £1,276,180.—From the *Fruit World*, March 1, 1914.

BABYLONIA, IRRIGATION IN. See *Irrigation*.

Bacteria

The subject of bacteria is treated here only so far as is necessary to give the reader some facts which will enable him to understand the references to the subject which are made in other parts of the work.

These minute organisms are sometimes called microbes, micro-organisms, microphytes, bacilli, microcci, etc. All of these terms are more or less limited in their

meaning and the term "bacteria" is the one in most common use.

Early in the history of the subject these minute organisms, of which there are now known perhaps a quarter of a million species, were called by the general name of *animalculae*. The term implies what was believed to be the case that these organisms were animals, but the classification was later discovered to include plants as well as animals. In the unicellular forms it is often impossible to determine which is animal and which plant and in this discussion it is not important to do so. In general, bacteria are defined as minute organisms, devoid of chlorophyl, unicellular, spherical, oblong, cylindrical or filamentous, and multiplying by division.

Distribution

Bacteria exist practically everywhere; in ponds, ditches, streams, seas, refuse, meat, milk, beer, fruits, vegetables, soils, and enter into all putrefactive processes.

Nitrifying Bacteria

The bacteria in which the farmer is most interested are the various soil bacteria and the nitrifying or nitrogen gathering bacteria in particular. It has been

discovered that certain forms of bacteria are capable of fixing free nitrogen. These are found most often on the leguminous plants where they collect in nodules. The physical action of these colonies is to break up the organic matter in the soil and, through the action of certain acid by-products, the inorganic as well. They thus render soluble the various elements in the soil which are necessary for plant food. In addition they seem capable of utilizing free nitrogen from the air in such a way as to increase the quantity of this element in the soil. Thus the nitrogenous or leguminous plants such as clover, vetch, alfalfa, beans, peas, etc., tend to improve the quality of a soil which is in need of nitrogen.

Prof. H. Marshall Ward, University of Cambridge, says:

"These bacteria can build up organic matter from purely mineral sources by assimilating carbon from carbon-dioxide in the dark, and by obtaining their nitrogen from ammonia. The energy liberated during the oxidation of the nitrogen is regarded as splitting the carbon-dioxide molecule—in green plants, this work is done by the solar rays. Since the supply of free oxygen is dependent on the activity of green plants, the process is indirectly dependent on energy derived from the sun, but it is nevertheless an astounding process and outside the limits of our previous generalizations."

Important results often occur, in the fact that these bacteria tend to disintegrate stone, rot sand particles, rust iron and copper, rendering their particles soluble.

Saprophytic and Parasitic Bacteria

Saprophytic bacteria are those which live in dead matter whether animal or vegetable. They are associated with most decomposing processes.

Prof. A. C. Abbott, of the University of Pennsylvania, says:

"The saprophytic group comprehends many species used in the fine arts and industries—such for instance as those concerned in the production of certain organic acids; those employed in the manu-

facture of indigo by the fermentation process and in the preparation of hemp; and in those used in the manufacture of cheese and butter. In the study of this large group, one constantly encounters other species presenting most engaging characteristics. Some of these varieties have the property of producing, during the course of their growth, pigments of great beauty—brilliant reds, delicate pinks, rich purples, yellows ranging from the palest lemon to the deepest orange. In another group, we meet with species having the emission of light as their most singular peculiarity. When growing, these forms glow with a peculiar phosphorescence, and it is significant to note that these luminous varieties have been most frequently encountered in the sea, and upon articles from the sea. The evil odors of putrefaction are the results of saprophytic bacterial development.

"In the *parasitic* group of bacteria, we encounter those species that exist always at the expense of a living host, either animal or vegetable, and in doing so not only appropriate materials necessary to life, but give off in return waste products that may act as direct poisons to the host. Fortunately this is a much smaller group than the saprophytic. In no particulars, save for their ability to exist at the expense of a living host and cause disease, are the disease producing bacteria distinguishable from the innocent varieties. The essential difference between the disease producing and the innocent bacteria, is that the former possess as their most striking physiological peculiarity, the power of elaborating toxins or poisons, that have a direct effect, or destructive action upon the tissue of their host."

H. Marshall Ward says: "A long list of plant diseases has of late years been attributed to bacterial action. Some, *e. g.* the Sereh disease of the sugar cane, the slime fluxes in oaks and other trees, are not only very doubtful cases, in which yeast and other organisms such as fungi play their parts, but it may be regarded as extremely improbable that the bacteria are the primary agents at all. They are doubtless saprophytic forms, that have

gained access to rotting tissues, injured by other agents.

"Saprophytic bacteria can readily make their way down the dead hyph (branch) of an invading fungus, or into the punctures made by insects, and aphides have been accredited with the bacterial infection of carnations, though more recent researches by Woods go to show the correctness of his conclusions that aphides alone are responsible for the carnation disease. On the other hand, recent investigations have brought to light cases in which bacteria are certainly the primary agents in the diseases of plants. The principal features are the stoppage of the vessels, and the consequent wilting of the shoots; as a rule, the cut vessels on the transverse sections of the shoots appear brown and choked with a dark yellowish slime in which bacteria may be detected; examples in cabbages, cucumbers and potatoes."

A familiar example is that of the common blight of apple and pear. See article on this subject under *Pear*.

Prof. Ward observes further:

"In the carnation disease and in certain diseases of tobacco and other plants the seat of bacterial action appears to be the parenchyma, and it may be that aphides and other piercing insects infect the plants, much as insects convey pollen from plant to plant, or (though in a different way) as mosquitoes infect man with malaria. If the recent work on cabbage diseases may be accepted, the bacteria make their entry at the water pores at the margins of the leaf, and thence by way of the glandular cells of the tracheids. Little is known of the mode of action of bacteria on these plants, but it may be assumed with great confidence that they excrete enzymes and poisons, (toxins) which diffuse into the cells and kill them, and that the effects are in principle the same as those of parasitic fungi. Support is found for this opinion in Beyerinck's discovery that the juices of tobacco plants affected with a disease known as 'leaf mosaic,' will induce this disease after filtration through porcelain."

Method of Study and Discovery

How to discover the specific cause of any disease, is a question of the greatest importance. This is done generally by three steps:

First. The discovery of disease in the affected tissues.

Second. Obtaining the bacterium of this disease, in pure culture.

Third. The production of the disease, by inoculation, with a pure culture.

By means of microscopic examination more than one organism may sometimes be observed in the tissues, but one single organism by its constant presence and special relation to tissue changes, can usually be selected as the probable cause of the disease, and attempts towards its cultivation can then be made.

In cultivating bacteria, outside the body from which it is originally taken, the food material in which it is cultivated, must first of all be sterilized by heat. This food material should be as nearly like that of the body from which it is taken, as possible. The media are used either in a fluid or solid condition, and are placed in glass tubes or flasks plugged with cotton-wool.

Inoculation

In testing the effects of bacteria by inoculation, young and vigorous cultures must be used, and in the case of plants, injected into the sap at some point where the cells are vigorous, or in the case of animals, by means of a hypodermic syringe into the subcutaneous tissue into the vein, into one of the serous sacs, or more rarely into some special part of the body.

Immunity

By immunity from disease, we mean, non-susceptibility; or not being susceptible by means of infection, contagion or inoculation. The entrance of a bacterium or any number of bacteria into the tissues, does not mean disease, necessarily. Even though the bacteria be virulent or poisonous, the plant or the person may have resisting power sufficient to neutralize its effects. With regard to diseases in persons, it has been shown that certain races are practically immune from

certain diseases, as in the case of the Negro in relation to malarial diseases.

In certain physical conditions, persons and plants are more susceptible than others, as in the case of fatigue, starvation, exposure to cold and whatever would tend to lower the vitality. This has been observed to be true in plants as well as in animals. A tree that is not properly nourished, is susceptible to many forms of disease, to which the healthy tree is immune. On this general subject, Professor Muir, of the University of Glasgow, says:

"In this way conditions formerly believed to be the causes of disease, are now recognized as playing their part in predisposing to the action of the true causal agent, viz.: the bacterium. In health the blood and internal tissues, are bacterium free; after death, they offer a most suitable pabulum for various bacteria; but between these two extreme states are conditions of varying liability to infection. It is also probable that in a state of health, organisms do gain entrance to the blood from time to time and are rapidly killed off. Immunity is generally spoken of under three distinct heads:

"First. Natural immunity.

"Second. Active immunity.

"Third. Passive immunity.

"Natural immunity may depend upon lack of sensitiveness to the bacteria or its toxins; as in the case of pear blight, which might enter the tips of the branches or the flowers, but could not enter where the bark is thick, unless injected by some insect or instrument.

"Active immunity is illustrated in the case of persons who after recovering from an attack of certain infective disease, such as smallpox, are not susceptible to subsequent attacks. Or, it may be illustrated again, by persons who have been inoculated with bacteria, that produce a modified attack of the disease as a prevention from attack in its more virulent form. Sometimes the injections are small at first, and are increased from time to time, and in this manner persons have been rendered free from snakes,

scorpions and certain vegetable toxins. It is noted that the stings of bees, which to some persons are very poisonous, are not so to the same persons, after having been stung a number of times.

"Passive immunity is secured by giving anti-toxins or anti-sera."

GRANVILLE LOWTHER

BALANCED SOILS. See *Soil*.

Banana

The fruit of the banana plant *Musa sapientum* grows in clusters of large finger-like forms, upon a very large spike or stem, containing, within a red or yellow rind, a nutritious pulp. This pulp is usually seedless and constitutes an important article of food. In some of the islands of the Pacific, it is a staple article of diet for the natives.

Scientists have recognized and classified as many as 40 different species, ranging from the ornamental groups that do not develop fruit, to the giant bananas, the *Platano* of the Spaniards.

The red banana is not common in the American markets. "There is a reason." In the United States it is used only to "dress" fancy baskets of fruit, but in the tropical countries it is quite a favorite. The individual banana is large, but the stalk does not carry as many "hands" as the yellow varieties, so as it does not bring as large a price to the grower and wholesaler, its extensive cultivation is not encouraged.

Banana culture is one of the oldest of industries. It has been known since the origin of the human race. Long before the dawn of history in the Old World, perhaps long before the Old World rose from the waters, man lived on the fruit of the *Musas*. The banana was generally considered a native of Southern Asia and to have been carried into America by Europeans, until Humboldt threw doubt upon its purely Asiatic origin, quoting early authors who asserted that the banana was cultivated in America long before the Conquest. It is claimed that at the time of the Incas in Peru, bananas formed one of the staple foods of the natives of the warm and temperate reg-

ions of the Montana. In spite of the uncertainty as to just which country may claim the fruit as indigenous, all tropical lands assert their right to it.

The first importation of bananas to the United States occurred in 1804, when the schooner Reynard, on a voyage from Cuba, brought into New York, as a commercial venture, a consignment of 30 bunches; but the real beginning of the trade dates back to 1866, when Mr. Charles Frank undertook the importation of fruit from Colon to New York. Previous to that venture small cargoes consisting mainly of the red banana had been received at irregular intervals from Cuba. In 1870, Captain Baker, an owner of a Cape Cod schooner, took a charter to carry gold miners and machinery 300 miles up to Orinoco river in Venezuela. After discharging his cargo, Captain Baker ran into Jamaica to secure some cocoanuts as ballast to New York, carrying a few bunches of bananas on the deck as an experiment. The result promised a great future for the industry on that island, which has been fulfilled, the exports last year reaching \$4,000,000.

On the American continent, bananas are successfully grown through 50 degrees of latitude, from Tampico, Mexico, 25 degrees north, to Asuncion in Paraguay, in the Tropic of Capricorn, 25 degrees south—a belt over 3,000 miles in width. Cultivation of the fruit is practically restricted to the eastern coast line, for the banana is one of the thirstiest of plants, and can not be expected to produce its maximum amount of fruit in districts where there are less than 100 inches of annual rainfall. Unfortunately for humanity, great areas of the land lying within this belt are high, dry, and sterile, while others are sandy or rocky, so only a small fraction is so located that banana growing can be made profitable. The altitude must not invite danger of frost, and high temperature is necessary for the growth. The southern coast of the Mexican Gulf, the Puerto Barrios section of Guatemala, the Puerto Cortes district of Honduras, the Puerto Limon district of Costa Rica, the Bluefields district of Nicaragua, the Bocas del Torro region of

Panama, the Colombian province of Santa Marta, and certain portions of Cuba, Jamaica, the Dominican Republic, Haiti, and Dutch Guiana, all combine the favored elements of soil and climate.

The plant has two natural enemies—the gopher and the wind storm—but against almost all other tropical conditions its hardihood is remarkable. It is practically immune from insect pests, and a worm-eaten banana or the stalk of a bunch practically destroyed by any of the boring insects of the tropics is unknown. The damage from high winds can be avoided or minimized either by planting in locations protected from storms or by leaving unfelled strips of native forest as protective screens. Where the gopher interferes, it can be fought by the use of carbon bisulphite. There is, however, a “witch broom” disease which has affected the Gros Michel variety in Dutch Guiana, and a “Panama” sickness which has attacked certain other varieties.

It is a matter of common observation that the banana is absolutely seedless, cultivation through innumerable generations having led to a vegetable method of propagation. Some of the primitive seed-bearing varieties are still said to exist in isolated regions of the Far East.

Clearing the Land

The first step toward cultivation is the clearing of the land. Into the tangle of shrubs and vines and the thick snarl of tropical vegetation the laborer comes with an ax and “machete” and cuts low everything but the giant trees. When all of the small timber and brush has been felled planting is commenced.

Planting

Young shoots are obtained from a plantation already in bearing, and these are placed in rows about 12 feet apart. When the planting is finished, the only labor necessary is to keep down the weeds and carefully clean the ground about the root of each stalk.

Growth

The banana plant will grow with wonderful rapidity under favorable circumstances. In fact, the development from a

newly-planted sucker to the plant in full bearing is simply short of marvelous. Within a space of six or seven weeks the 2 or 3 foot plant has more than doubled in size, and a month or so later the leaves cease to unfold and a spike appears out of the center of the crown. This is the future stalk of the bunch and carries a huge red blossom at the end. It develops rapidly, continually bending more and more until in a short time it has turned completely upon itself, so that the bananas grow end up or in a position the reverse of which they are usually hung. From 7 to 12 months after the blossom appears the fruit is ready for the gatherer. At irregular intervals along the entire stalk, and only extending part of the way round at any one place, the bracts break forth tiny ridges of flowers—which are almost immediately replaced by 9 to 12 embryo bananas. These are the future “hands” of the bunch, so called on account of their resemblance to those members when held in a certain position.

It is by means of these hands that the fruit is classified for shipping. A bunch of 9 hands or over (the average being 10 to 12) constitute a “first,” between 7 and 9, a “second.” Anything under this minimum is discarded by an inspector at the wharf. Bunches of 17 hands are exceptional, and those of this abnormal size are usually not shipped, owing to the inconvenience of storing in the steamer’s hold.

Propagation

The banana has a curious and prodigal method of propagation, for before the parent stalk and fruit have matured new ones spring up. These are offshoots that grow from the root of the original planting, resembling the sprouts from the “eyes” of a potato, and each in turn becomes a parent stalk with its fruit. It follows that unless most of the continually appearing new plants are cut out (which is the practice) the first stalk in a few years will become the center of a miniature jungle. The plants grow to a height of from 15 to 35 feet, spreading in all directions, until the soil is overburdened with an enormous mass of stalk

and leaf growth, and stunted fruit is produced.

In cultivation, four suckers (which is another name for the shoots) are usually allowed to grow in one hill, and their graduation is so arranged that while the oldest is bearing fruit the next is in blossom, the third is half grown, and the last is just coming forth from the ground. The banana plantation yields a continuous harvest for years without replanting. Some that are fifty years old are yielding today as prolifically as in their third or fourth year, but these are located in exceptionally fertile districts. The rotation of crops is unknown, and unless the land is subject to overflow it can hardly be profitable after ten years’ working.

Planting

In planting for the market about 200 hills are allowed to the acre. Sometimes the number can be safely increased to 225, in which case there will be 900 stalks. However, after one year all of these stalks do not produce a marketable bunch of bananas, and the average yield is not over 300 full bunches to the acre per annum.

FRANKLIN ADAMS,
Pan-American Union

Banana Flour

During the past two or three years many popular statements have appeared concerning banana flour or meal. Little reliable information, however, has apparently been available on this subject. Banana flour is prepared by cutting the fruit into suitable pieces, drying, and grinding. Several years ago the Royal Gardens, Kew (England), published a somewhat extended discussion of the food value of bananas and banana flour and stated that the latter article, according to the testimony of travelers, had been prepared by native inhabitants of tropical countries since early times. The Connecticut State Station recently published analyses of banana flour made from three sorts of bananas. In the following table the composition of these samples is shown. For purposes of comparison, the composition of fresh bananas, wheat flour, rice, and fresh and dried apples is also included.

Composition of Banana Flour and Other Foods

	Water	Protein	Fat	Carbohy- drates	Fiber	Ash
Banana flour:	<i>Per cent.</i>	<i>Per cent.</i>	<i>Per cent.</i>	<i>Per cent.</i>	<i>Per cent.</i>	<i>Per cent.</i>
From Porto Rico fruit	13.43	3.50	0.47	79.82	0.54	2.24
From Florida fruit	5.34	2.81	.66	87.45	.84	2.90
From Honduras fruit	10.33	2.87	.50	87.02	.73	2.55
Bananas, fresh, edible portion.....	75.30	1.30	.60	21.00	1.00	.80
Apples, fresh, edible portion.....	84.60	.40	.50	13.00	1.20	.30
Apples, dried	28.10	1.60	2.20	66.10	2.00
Wheat flour, patent roller process....	11.50	11.40	1.00	75.40	.20	.50
Rice	12.30	8.00	.30	78.80	.20	.40

Dried ground bananas are seen to contain in the same bulk more nutritive material than the fresh. This would naturally be the case, since a large part of the water in them was removed in drying. Fresh bananas and apples are somewhat similar in chemical composition and the same is true of the dried products. The dried apples contain somewhat more water and hence less nutritive material than the dried and ground bananas. Banana flour contains much less protein than wheat flour.

As pointed out by the Connecticut State Station, the three samples of banana flour analyzed are quite alike in composition. They contain less than half as much protein as rice. Their nutritive value rests almost wholly in the materials which constitute nitrogen-free extract. In those countries where banana flour is prepared in considerable quantity, it is used in combination with milk, sugar, etc., in the preparation of custards, cakes and similar articles.

C. F. LANGWORTHY

Imports of Bananas—Years Ending June 30, 1909-1913

Imported from	1909	1910	1911	1912	1913
<i>BANANAS (Free)</i>					
North America:	Bunches	Bunches	Bunches	Bunches	Bunches
British Honduras	413,300	416,218	549,060	557,160	651,064
Canada	3,918	2,047	9,626	10,299	4,398
Central American States—					
Costa Rica	5,912,200	8,193,800	7,387,700	7,053,664	6,973,684
Guatemala	658,300	755,600	1,458,500	2,017,650	2,359,250
Honduras	5,624,807	5,364,831	6,901,895	7,151,178	7,983,591
Nicaragua	1,171,800	1,286,581	2,139,732	2,270,100	1,681,944
Panama	3,772,561	3,402,500	4,043,000	4,581,500	4,438,300
Salvador	352
Mexico	212,214	241,324	584,842	817,006	1,541,504
West Indies—					
British—					
Barbados	} 14,705,454	} 14,380,498	} 15,322,867	} 15,467,918	} 11,163,269
Jamaica					
Trin. and Tobago..					
Other British					
Cuba	2,407,918	2,223,210	2,670,200	2,478,581	2,213,733
Dutch	17,000
Santo Domingo	140,000	218,000	509,308	304,000	475,500
South America:					
Brazil	50,481
Colombia	1,492,692	1,012,564	2,540,583	1,542,988	2,684,749
Guiana—Dutch	407,939	659,486	564,273	261,548	184,498
Total	36,973,584	38,156,659	44,699,222	44,520,539	42,357,109
RECAPITULATION.					
North America.....	35,022,472	36,484,609	41,594,366	42,716,003	39,487,862
South America.....	1,951,112	1,672,050	3,104,856	1,804,536	2,869,247

Imports of Bananas—Years Ending June 30, 1909-1913—Continued

Imported from	1909 Dollars	1910 Dollars	1911 Dollars	1912 Dollars	1913 Dollars
North America:					
British Honduras	101,930	101,741	137,495	130,703	163,249
Canada	5,316	2,048	7,660	6,936	4,111
Central American States—					
Costa Rica	2,186,545	3,031,556	2,785,758	2,713,532	2,744,813
Guatemala	168,825	192,363	363,690	509,017	600,041
Honduras	1,731,515	1,524,843	2,039,472	2,199,890	2,435,006
Nicaragua	207,961	222,858	395,612	415,389	348,064
Panama	958,117	918,331	1,784,495	2,137,890	2,082,502
Salvador	88
Mexico	35,180	52,507	116,700	226,836	413,315
West Indies—					
British—					
Barbados
Jamaica	4,564,680	4,403,341	3,488,498
Trin. and Tobago...
Other British	117	1,893	466
Cuba	891,773	841,327	897,314	942,481	834,206
Dutch	5,100
Santo Domingo	70,000	109,000	252,928	152,003	222,626
South America:					
Brazil	12,538
Colombia	362,248	243,905	887,928	453,271	1,107,429
Guiana—Dutch	127,013	161,871	136,126	66,060	39,932
Total	11,012,100	11,642,693	14,375,075	14,368,330	14,484,258
RECAPITULATION.					
North America.....	10,510,301	11,236,917	13,351,021	13,848,999	13,336,897
South America.....	501,799	405,776	1,024,054	519,331	1,147,361

World Production and Consumption of Bananas

A report upon the world production and consumption of bananas, from Consul Julius D. Dreher, Port Antonio, Jamaica, was published in the Daily Consular and Trade Reports of December 26, 1912. According to this report Jamaica was far ahead of all other countries in the exportation of bananas during the calendar year 1911, having shipped a total of 16,497,385 bunches, valued by colonial officials at \$7,088,451, or more than one-half of the total value of all exports from the island in that year. Costa Rica ranked second, with exports of 9,309,586 bunches, and then came Honduras with 6,500,000 bunches, Colombia, 4,901,894; Panama, 4,261,500; Canary Islands, 2,648,378; Cuba, 2,500,000; Nicaragua, 2,250,000; Guatemala, 1,755,704; Mexico, 750,000; British Honduras, 525,000; Santo Domingo, 400,000; Dutch Guiana, 387,516, and other countries, 250,000, making a grand total of 52,936,963 bunches of bananas exported. It should be borne in mind that the world's actual production of bananas is far greater than the amount exported, since there are many isolated regions, like the numerous island groups of the Pacific ocean, that have no foreign market for their abundant crops of

this fruit, and in the countries which export bananas the home consumption is enormous. In Jamaica, as in other countries, the natives not only eat ripe bananas as a fruit, but they boil the green fruit and eat it as a vegetable and also use it in this form to fatten pigs.

As Jamaica is officially reported as having had 82,436 acres in bananas last year, when the exports amounted to 16,497,385 bunches, it appears that the average number of exportable bunches produced per acre was 200; and as the average market price as shown by American consular invoices issued to shippers was 27½ cents a bunch, the average gross yield for the island was \$55 an acre. In Panama and Costa Rica, where the land is very fertile and the plants are set farther apart, the average exportable crop is 140 to 150 bunches an acre; in Colombia it is nearly 200.

While Jamaica exported nearly twice as many bananas last year as any other country, the United States imported more than five times as many as any other country. For the fiscal year ended June 30, 1912, the bananas imported into the United States reached the enormous total of 44,520,539 bunches, valued at \$14,368,330, an average of 32.3 cents a bunch, as the market value shown in America con-

sular invoices certified at the shipping ports. Great Britain imported during the calendar year 1911 a total of 6,714,479 bunches, value \$8,943,099, an average of \$1.33 a bunch, the value fixed at the importing ports. During the same year the value of bananas (including banana food products) imported into Germany amounted to \$1,974,046. It should be stated that some of the bananas imported into Great Britain are sent to Germany and other countries of Northern Europe, and that Hamburg, which is a great distributing center, ships bananas arriving at that port to Scandinavia and elsewhere. France and other countries of Southern Europe receive very few bananas.

The banana supply of the United States was received from the following countries: Jamaica, 15,467,918 bunches; Honduras, 7,151,178; Costa Rica, 7,053,664; Panama, 4,581,500; Cuba, 2,478,581; Nicaragua, 2,270,100; Guatemala, 2,017,650; Colombia, 1,542,988; Mexico, 817,006; British Honduras, 557,160; Dominican Republic, 304,000; Dutch Guiana, 261,548; and other countries, 17,246 bunches. Estimating the average number of bananas at 140 to the bunch, it appears that the people of the United States consume over 6,000,000,000 bananas a year, or more than 5 dozen for every man, woman, and child in the United States, including Alaska and Hawaii.

The increasing consumption of bananas in a number of countries naturally raises the question of an adequate supply to meet the coming demand. In Jamaica, where the immense banana crop is produced on about 3 per cent of the total acreage of the island, there is yet plenty of suitable land available. In Mexico, Central America, Panama and Colombia, not to mention the large possibilities of Haiti and the Dominican Republic, there are vast tracts of land where a fertile soil, a warm climate, and abundant rainfall favor the production of bananas on a large scale. Not only is there land enough, but the profits of the crop are sufficiently remunerative to attract the investment of ample capital to meet the world's demand.

BEAM TREE. See *Apple, Botany of.*

Beans

The bean is one of the most widely cultivated of garden plants, and includes several varieties, among which are the following: Bunch bean, kidney bean, pole bean, string bean, butter bean, lima bean, haricot bean, French bean, and Carolina bean.

The following are not in common use, but are of historical interest. Carob bean, the fruit of the carob tree that grew in Palestine, the pod of which had a sweetish taste; same as locust tree.

Buck bean, a bog herb of the gentian family.

Brazilian bean, the fruit of a tree of the laurel family.

Calabar bean, the highly poisonous seed of an African climber. It is used chiefly for contracting the pupil of the eye, occasionally for tetanus, epilepsy and other nervous disorders. With the natives of old Calabar, it was a test for crime, witchcraft, etc., whence it came to be called the ordeal bean.

Egyptian, Pythagorean, or sacred bean, the fruit of the lotus.

Florida bean, the fruit of a West India, leguminous climber often washed up on the coast of Florida.

Sea bean, the fruit of a climbing shrub growing in tropical America.

Goa bean, the edible seed of an Indian plant.

St. Ignatius bean, the seeds of the logania family which yield strychnin.

Indian bean, the catalpa.

Scarlet bean or Spanish bean, cultivated for its scarlet flowers.

Tonqua bean, the fragrant seed of a large tree of the bean family.

The bean, usually cultivated for its food, is an annual, and is horticulturally divided into bush and pole varieties. Under the bush varieties, may be included all those that have stout, erect, or slightly twining stem. Under pole varieties are included those that have twining stems, and are benefited by having some kind of support, around which they may entwine. Certain varieties are often planted with corn, entwining around the stalk, and are familiarly known as "corn beans."

Navy Bean

The navy bean is a small white bean generally sown in drills about 18 inches apart between the drills, and about two to four inches apart in the row. This gives room for cultivation with a small plow. Sometimes they are sown broadcast, gathered in the autumn and threshed like wheat or oats. Sometimes the threshing is done with a flail, or by treading with horses.

Bunch Beans or Bush Beans

Bunch beans are planted in the garden, generally for home use, or for sale while green in the form known as "string beans." Included in the varieties of bush beans are White Marrow, Burlingame, Medium and Snow Flake.

Lima Beans

Among the varieties of Lima beans, are the dwarf Lima and the pole Limas. The dwarf varieties are growing into favor, because they require less work than the pole Limas. If the pole varieties are planted, as soon as the beans begin to vine, poles six to eight feet long should be set, one for each hill of beans, and the vines allowed to entwine about them.

The Soil

Unlike most other vegetables, the bean does not require a rich soil. If the soil is rich, it produces heavy vines, and not a heavy crop of beans. It is possible therefore, to grow beans successfully on soil too poor for ordinary crops. The bean is also a leguminous vegetable, gathering nitrogen and improving the soil conditions.

Varieties

Improved Prolific Black Wax, Extra Early Refugee, Bismark Black Wax Prolific, Dwarf Horticultural, Stringless Green Pod, Early Warwick.

GRANVILLE LOWTHER

Bean Growing in Eastern Washington and Oregon, and Northern Idaho

LEE W. FLUHARTY,

Assistant Agriculturist,

Office of Farm Management

The arable land of Eastern Washington, Eastern Oregon, and Northern Idaho has

been devoted almost exclusively to the production of wheat, oats, and barley for more than 30 years.

While wheat, oats, and barley are the crops most universally grown, a small portion of the wheat belt of Washington, Oregon, and Idaho is well adapted to the production of beans. The area best suited to this crop lies along the foothills of the Blue mountains in Umatilla county, Oregon, Walla Walla, Columbia, Garfield, and Asotin counties, Washington, and along the foothills of the Craig mountains and adjacent to the canyons of the Clearwater and Potlatch rivers in Nez Perce, Lewis, and Latah counties, Idaho. A few districts are in Whitman, Spokane and Stevens counties, Washington, where the climatic conditions are favorable for bean culture. While it is true that only a limited area is adapted to this crop a careful study of all the details of its production shows that thousands of acres now lying idle each year as summer fallow may be used for growing beans as an intertilled crop. This crop has been grown in parts of Nez Perce and Latah counties, Idaho, for the past 15 years, and the bean hullers make their regular fall runs the same as the grain thrashers. The crop has also been grown in a more limited way near Weston, Oregon, for 15 years. The production of field beans in this territory is therefore past the experimental stage. A few days spent in the vicinity of Kendrick, Idaho, visiting bean growers during the months of July and August will convince the skeptical of this fact.

Limiting Factors of Bean Production

Two factors largely determine whether beans may be grown successfully: (1) The annual precipitation must be sufficient to produce a crop each year and (2) the growing season from May 10 to September 15 must be approximately free from frosts. Owing to their proximity to the mountains the districts previously mentioned receive sufficient precipitation for growing beans when proper cultural methods are employed.

The deep ravines leading down from the mountains in these regions give pro-

tection from frosts during the growing season by furnishing excellent air drainage. While the danger from frosts increases with the elevation, air drainage is the principal regulating factor. In parts of Nez Perce county, Idaho, where the deep canyons furnish good air drainage, beans are being grown successfully at an elevation of 3,000 feet. In other parts of the same county having a lower elevation but poor air drainage, this crop can not be grown on account of the late spring and early autumn frosts.

The success of the bean crop also depends upon the quantity of moisture stored in the soil at the time of planting and upon the cultural methods employed in growing and harvesting the crop.

Cultural Methods Used in Bean Production

Experience has demonstrated that the success of the bean crop depends largely upon the thorough preparation of the seed bed. While it is not the general practice, the work of preparation should begin in the early autumn. The most successful growers work the grain stubble into the soil with a sharp disk harrow soon after the coming of the first fall rains. When the ground is plowed after such treatment the stubble is evenly distributed throughout the soil, where it quickly decays and prevents packing. It is not always possible to disk the stubble in the fall on account of the rush of work at that season. If, however, the plowing is delayed until the following spring, fall disking is very necessary.

Planting the Bean Crop

Time to plant.—The time of planting varies from May 10 to June 5, according as the season is early or late. When planted too early, cold weather, together with an excessive quantity of moisture in the soil, often causes the seed to decay before germination begins. Even if a good stand is secured under such unfavorable conditions the crop usually develops and ripens very unevenly.

Method of planting.—The double-row bean and corn planter is used almost exclusively for planting the crop. An ex-

cellent type of planter is now in use. This planter may be adjusted to plant in rows from 28 to 44 inches apart. By using a special 30-inch wire it will also plant the hills in 30-inch cross checks. The feed plates may be made to drop the desired number of seeds in each hill by regulating their speed. The planter is also equipped with an automatic hill-drop attachment which drops the hills from 17 to 52 inches apart in the row. If the ground is so foul as to require extensive cultivation the beans should be planted in checks with the hills 30 to 36 inches apart to permit cultivation in both directions.

It is considered very essential that the number of plants grown on a certain area be sufficient to maintain a proper balance between the soil moisture and the moisture requirements of the plants. If this balance is properly maintained the beans ripen evenly and a uniform crop is produced. In the sections where beans are being grown at present, from six to eight seeds in each hill produce the proper number of plants. If a smaller number of seeds is planted in each hill there is often moisture enough in the ground to keep the vines growing late in the fall, and the late beans are sometimes damaged by early fall frosts. This problem must be worked out, however, for each locality having different soil and moisture conditions.

A hand corn planter is often used for planting where only a small acreage is to be grown. The ground is marked off in checks about 30 inches square and the beans dropped at the intersection of the marks. An experienced man can plant from four to seven acres a day by this method. If the ground is free from weeds, so that but little cultivation is necessary, the seed is often planted in drill rows with either a bean planter or an ordinary grain drill. Of the two, a bean planter which has a drill attachment is the more desirable.

A grain drill having feed cups which will handle beans may be used with fair success. An 11-row grain drill with a space of seven inches between each drill

tube can be adjusted for drilling beans in rows 28 inches apart by stopping up all of the feed cups except the second, sixth and tenth. The machine is so regulated as to plant the seed from three to six inches apart in the row.

The depth at which the beans are planted depends upon the character of the soil and the weather conditions. They are not planted so deep in dark, heavy soil as in a lighter soil. Neither can beans be planted to a very great depth during cold, damp weather without injuring the stand. The safe plan is to plant just deep enough for the seed to lie in moist earth, for an even stand of strong, healthy plants is one of the first requirements of a good bean crop.

Quantity of Seed Per Acre

The quantity of seed required per acre depends upon the size of the beans and also upon the manner of seeding. The pea bean varieties, such as the Little Navy, the Lady Washington, and the Red Miner, require from 16 to 20 pounds per acre when planted in checks 30 to 36 inches square. If planted in drills or checked closer than this a larger quantity of seed will be necessary. The larger seeded varieties require more seed per acre than the smaller varieties.

Beans as a Truck Crop in the South

W. P. WILLIAMS

The raising of bush or snap beans, as they are called, is becoming a prominent industry in some sections. The bean adapts itself readily to companion cropping; has a short period of growth (60 to 70 days); is fairly easy to grow, and is thus gaining favor as a truck crop.

Beans may be grown on any garden soil, but a rich sandy loam, with porous subsoil is preferable for early crops. Land for this crop should be manured and plowed as soon in the spring as possible. It should be disked and harrowed until it is well pulverized, and if planting is delayed harrow every week until ready to plant.

The bean, being a leguminous plant, does not need heavy application of nitrogen. An application of the following

amount of fertilizer per acre will give very good results, and is a 9-2½-5 goods.

Acid phosphate (16 per cent)	300 lbs.
Cotton seed meal	.200 lbs.
Muriate of potash	50 lbs.

Some growers use only cotton seed meal at the rate of 700 pounds per acre, and a dressing of 100 pounds of nitrate of soda at blossoming time. By the above method the succeeding crop gets the benefit of fertility not available for the present crop.

Beans are sown in drills four feet apart and quick maturing crops, such as radishes, are planted between the rows or later crops, like cotton, corn or potatoes, are planted when the beans have reached maturity. Many growers practice sowing a successive crop of beans between the rows.

Cultivation should begin as soon as the plants push through the ground, and this should be continued at frequent intervals throughout the growing period. The cultivation should be shallow, and the soil should be ridged slightly toward the plants.

The seed is sown in drills and covered about two inches. Seed sown early is apt to rot, so it should be sown quite thickly. One quart of seed will plant from 80 to 100 feet of rows. Early sowings are apt to be caught by frost, as the young plants are very tender, but the prices of early shipments are so good that some risk may be run to receive these high prices.

Varieties recommended for the South are Red Valentine, Stringless Green Pod, Refugee and Golden Wax. Pole varieties such as Kentucky Wonder and Old Homestead are good, as they last over a longer season than the bush varieties.

Beans are ready to harvest from eight to ten weeks after planting. The beans are picked when of sufficient size, but they are not allowed to become tough and stringy. Never pick beans when the foliage is damp, as many growers claim this causes rust and anthracnose to spread more rapidly. Anthracnose is controlled by growing seed which is desired for planting the following spring, in the

fall; if there should be some disease in the fall crop, select seed only from healthy pods, and follow the recommendations as given above for cultivation and picking.

The beans when picked are sorted and packed in hampers holding about seven-eighths of a bushel and are then loaded into refrigerator cars. The cost of shipping a car to Northern markets is about \$125, and the cost in these car lot shipments is about 30 cents per hamper.

A good yield of beans is 150 hampers per acre, and prices are sometimes as high as \$3.00 and more per hamper, for very early shipments. Many growers figure that the crop of beans pays all the fertilizer and necessary expenses for the culture of the succeeding crop, and thus the price received for the latter crop is clear profit.

BEAN DISEASES

Anthracnose—Spot

Colletotrichum sp.

Causes large, scabby, dead spots upon the pods.

May be controlled by selecting clean seed and spraying the plants with Bordeaux mixture.

Bacterial Spot—Blight

Bacterium phaseoli Erw. Sm.

Leaves, pods and stems show watery spots. Not so prevalent on new land.

Powdery Mildew

Erysiphe polygoni

Produces a white growth of the fungus covering the surface of the leaves in moist weather.

Sprinkle with dry sulphur.

R. E. SMITH,
Berkeley, Cal.

Rust

Uromyces appendiculatus

Causes a yellowing and death of the leaves with the production of a dusty red rust on the under side. Not usually destructive except on plants growing poorly.

R. E. SMITH,
Berkeley, Cal.

BEAN PESTS

BEAN APHIS. See *Aphids*.

Bean Cutworm

Ogdoconta cinereola Gwen.

The caterpillar of this species does injury to the foliage and pods of beans, at times stripping them. The larvae is a looper, pale green with three white strips and measures, when full grown, about an inch.

It is distributed pretty well over the country east of the Rockies, but has been



Fig. 1. The Common Cut Worm *Peridroma Margaritosa*. —After Essig.

destructive so far only in Florida and Mississippi.

Arsenical sprays will control it though care should be taken to thoroughly clean the pods if they are to be eaten.

Bean Weevil

Acanthoscelides obtectus Say

Family Bruchidae.

Bruchus obtectus Say

General Appearance

The adult weevils are very short and robust, measuring about one-eighth of an inch in length. The odd shape is due to the wing covers being shorter than the abdomen, and the head being carried at right angles to the body. The color varies from gray to brown with a velvety greenish tinge. The eggs are white and less than a millimeter long. The grubs are very small, a number of them being able to occupy a single small white bean. They are light cream colored and

robust. The pupae are first light, gradually becoming darker with age.

Life History

The adult beetles after hibernating or breeding in stored beans over winter appear in the spring about the time the beans are blooming and lay their eggs upon the pods, in cracks at the end or in slits made by the female's jaws. Upon hatching the young larvae bore through the pod or reach the beans within through a natural crack and begin to enter them by drilling a small hole, the entrance of which either heals over or is so small as to be unobserved. Once within the bean the entire life history is spent there, the adults emerging at will by cutting a circular hole in the side. The adults of the first brood immediately begin egg laying upon the pods as did the hibernating females in the field, but if in storage bins or sacks the eggs are laid upon the seed beans or in old burrows. They thus continue to breed throughout the entire summer and winter if the weather is not too cold, many generations appearing each year.

Distribution

This insect is generally distributed throughout the state, and is particularly troublesome in the central and southern counties where small beans are raised.

Foods

Nearly all varieties of beans are attacked by this weevil, though the small white and brown varieties are preferred. Limas are not usually affected, but occasionally they are attacked. Peas are also included as a host.

Control

The first step in the control of this pest is to harvest the beans just as soon as possible, for those left in the fields are sure to become largely infested. If any of the insects are discovered the beans should be thoroughly fumigated with carbon bisulfid before they are stored. If weevils appear in the bins or sacks, fumigation should be resorted to at once.

E. O. ESSIG



Fig. 1. The Work of the Bean Weevil on Small White and Lima Beans. (Original.)

Bean Thrips

Heliothrips fasciatus Pergande

General Appearance

The adult insect is black with head and thorax dark brown; antennæ are whitish with tips dark; legs are black and yellow; front wings are blackish with white base; posterior wings uniformly yellow with dark fringes. The young stages are lighter in appearance than the adult.

Life History

According to H. M. Russell, the insects hibernate in the adult stage only, under leaves, rubbish, etc. The eggs are inserted in the leaves or tender stems. The young begin feeding soon after hatching. When ready to pupate the larvae seek shelter under rubbish or in the ground, where the nymphal stage is completed



Fig. 1. Bean Thrips. (Enlarged)
—After Russell

and the adults emerge. There is an overlapping of broods so that during the summer months all stages may be found.

Distribution

The bean thrips are found in Idaho, California, Arizona and Kentucky.

Food Plants

Due to its large numbers this insect has proved a serious pest to oranges, alfalfa, pear trees and various garden crops, the work being the same as that of other members of the family.

Control

Control measures for this pest are the same as recommended for pear, citrus or grain thrips, depending upon the plants which are infested. See Pear.

A flour paste consisting of from six to eight pounds of cheap flour to 100 gallons of water and applied thoroughly has given excellent results in controlling this pest upon truck crops, such as beans, peas, beets, etc., which have tender foliage.

E. O. ESSIG

Flea Beetle

Systema blanda

Several flea beetles attack field beans. Probably the most troublesome is the pale-striped flea beetle. It is only during

hot, dry summers that these tiny creatures make their attacks, but at such times they are likely to appear in myriads in fields of beans and sugar beets, as well as in all sorts of garden truck.

The name flea beetle is suggested by their habit of jumping when disturbed, very much like a flea.

The beetles themselves are only about one-eighth of an inch in length and creamy in color, with thin, longitudinal stripes of light brown on the wing covers. The larvae are slender, thread-like creatures, white in color with yellowish heads. They feed underground on the roots of weeds for the most part.

The effect of many tiny beetles eating holes in the foliage is to shrivel the leaves and, if the plants are very small, to kill them outright.

Remedies

The beetles winter as adults, which at once suggests the burning of rubbish about the farm and in the fence corners.

Bordeaux is a very valuable repellent. Bordeaux, however, is apt to burn the leaves of beans and arsenate of lead is probably the safest and best remedy.

R. H. PETTITT,
East Lansing, Mich.



Fig. 1. Pale Striped Flea Beetle. Enlarged.
(Author's illustration.)

Four-Spotted Bean Weevil*Bruchus quadrimaculatus*

An old enemy of cow peas. It also works in the common bean and, like the common bean weevil, it works indefinitely in the stored seeds until nothing of value is left. As this beetle is larger than the bean weevil, its work is comparatively rapid.

Like the bean weevil, this creature starts work in the field, coming into the granary with the harvested beans, or it may gain access after the beans have been stored away.

Remedies

Fumigation of the seed during warm spells with carbon bisulphid is the best remedy thus far discovered.

R. H. PETTIT,

East Lansing, Mich.

HARLEQUIN CABBAGE BUG. See *Cabbage*.

Ladybird*Epilachna corrupta*, Muls.

The beetles belonging to the ladybird family are quite common in this section. They are small oval or hemispherical in shape and are red and brown with black spots or black with red or yellow spots. These beetles are divided roughly into two classes, beneficial and injurious. The beneficial species feed on plant lice and scale insects. The ladybird is troublesome throughout New Mexico and occasionally it becomes very injurious, especially to the bean crop. This beetle devours all parts of the bean plant in both the larval and adult stages. The yellowish brown eggs are laid in clusters on the under surface of the leaves.

The larvae has a yellow color and is covered with ugly branched spines. The matured beetle is light yellowish brown with eight black spots on each wing cover. This beetle is the one locally known as *La chinche del frijol* by the Mexican bean growers. The insect winters over in the adult stage and so far as it is known there is but one brood a year. It seems that in New Mexico the wintered over beetles appear about the last of June to the middle of July and the generation from these is developed in August and September.

Remedies

By judiciously using Paris green and arsenate of lead many of the larvae and adults can be killed. Greater care should be taken when using Paris green, since it is liable to injure the foliage. Kerosene emulsion is sometimes used with quite a degree of satisfaction. In small gardens hand picking of the first beetles in the summer and destroying the eggs may aid considerably in reducing the number of the late brood. Clean culture, as destroying all weeds and rubbish in the field, fall plowing, and harrowing would undoubtedly reduce the number of adults that will winter over. As there seems to be but one brood and this is most troublesome to the late crop the injury could be materially reduced by planting the beans as early as possible.

Lima Bean Pod Borer*Etiella zinckenella* Treit.

Family Pyralidæ

General Appearance

The adult moths are gray with ochreous blotches on the fore wings. There is a



Fig. 1. The Work of the Lima Bean Pod Borer, *Etiella zinckenella* (Treit), on Bush Lima Beans. (Original.)

plain, broad, white band along the margins of these wings and an ochreous band with brown spots across the inner fourth. This band is especially conspicuous. The hind wings are light gray. The moths are small, scarcely more than one-half inch long. They are exceedingly active on wing and foot. The pupa is rich brown and usually enclosed in a thin white cocoon. The young larvae are white or light green. When full grown they are white or distinctly reddish above and greenish beneath. The head is dark as is also the prothoracic plate and the legs. They average about one inch in length. When disturbed they wriggle violently.

Life History

The writer has never seen the eggs so is unable to state where they are deposited, but judging from the observance of their work they are probably laid upon the bean plants and the pods as soon as they are formed. As soon as hatched the young caterpillars bore through the pods and begin feeding upon the beans inside, all of which are usually gnawed into or destroyed before fully developed. When ready to pupate the larvae either do so in the pod or select some other place. Very often they crawl into the ground and pupate under clods or any convenient shelter. As a protection a thin white cocoon is spun. In this stage some of the insects hibernate though many appear as adults in late summer and fall. There is but one brood a year. The adults appear in the spring about May.

Distribution

Apparently across the southern half of the United States and in Europe.

Food Plants

The beans in the pods of the small bush lima beans are the favorite food for this moth, though it occasionally attacks those of the large limas.

Control

Early beans are the ones suffering from the attacks of the caterpillars, though the later plantings do not escape. As the bush lima is usually the only crop at-

tacked it would be well to plant the large and later varieties instead.

E. O. ESSIG

RED SPIDER. See *Apple Pests*.

Seed Corn Maggot

Pegomya fusciceps

One of the causes of failure of germination of seeds in the ground is the seed corn maggot, otherwise known as the bean maggot. It is said to attack the seed of peas, corn and beans, and also to work on a varied list of plants including pumpkin, cotton, orange, artichoke, strawberry, cabbage, beets, onion, mustard and other plants.

The attack is most serious when made just after the germination of the seed. Later attacks are less apt to kill outright, though naturally they are bound to diminish the crop. With the young beans the attack is likely to occur just as the beans are nicely appearing above the ground. The cotyledons are blackened and the young central shoot often is shrivelled and dead. Maggots are often to be found in the decaying cotyledons or in the fleshy stems beneath the surface of the soil. This occurs during the first part of July. The adult flies appear in the third week in July.

The maggots appear very much like those of the onion maggot and those of the cabbage maggot, being white, tapering, and about one-fourth of an inch long. The adult fly looks like a miniature house fly, being about one-fifth of an inch long.

The seed corn maggot is credited with breeding in decaying vegetation and also in fresh manure.

Remedial Measures

The standard repellents, sand and kerosene, and carbolic acid emulsion can be used when the beans are in the garden, just as in the case of radish and onion maggots. However, in the field, such methods are hardly practicable. The avoidance of freshly applied stable manure and the substitution of commercial fertilizers during the year that beans are raised on a given piece of ground, should prove beneficial when the maggot has once made trouble. Of course beans should never be planted where the mag-

got is known to have been recently, nor in fact should they be planted in very close proximity to a recent outbreak.

R. H. PETTIT,
East Lansing, Mich.

TWELVE SPOTTED CUCUMBER BEETLE. See *Cucumber*.

BEANS, VELVET. See *Apple Orchard Cover Crop*.

Bees

Before discussing the subject of bees in the orchard, we will describe briefly the nature of bees in general; because it is only when we understand them that we are prepared to appreciate their relations to things affected by them.

Bees, like most animals and plants, are divided into families, species and varieties. Of the bees there are two distinctive families. The first is called, scientifically, *Andrenidea*, or Solitary Bees, having the underlip flattened and very short. The second is called *Apidae*, and are social in their instincts. The *Andrenidea* excavate nests in the turf, the grass and other substances in the fields, even making a deep pipe or hole with short lateral galleries in which the grub feeds and grows. These bees entertain guest bees called *Nomada*, so called because they lay their eggs in the nests of the *Andrenidea* where the young are hatched and share the food of their hosts as visitors share the food of friends. Here the adults seem to live harmoniously together, grow their young and sustain relations which seem more like a partnership than a case of parasitism.

The *Apidae* includes the Bumble Bee, the Carpenter Bee, Stingless Bees, and Honey Bees. The *Bombus*, or Bumble Bee, are familiar to all American boys, especially those who have lived in the country in the Middle or Eastern states. Upwards of fifty species of this bee inhabit North America; there are very few in South America, and none in Africa south of the Sahara, or in Australia; while they are the only bee inhabiting the Arctic and Alpine regions. This bee is sometimes called the Humble bee, and is recognized by its large, thick, hairy body and deep bass hum. The colonies of

Bumble bees are not numerous as compared with those of the Honey bee, but they are more vicious and the sting is very severe. Their colonies are not large, perhaps not more than one-tenth the size of the colonies of the Honey bee. In good weather and when the flowers are abundant they collect honey and store in the cells from which the young were hatched.

The Carpenter bee, called in science *Xylocopa-virginica*, is called the Carpenter bee because it bores in the wood of dead trunks of trees, lumber, and sometimes in buildings. It is a large black bee, as large as the Bumble bee or sometimes larger. It bores horizontally across the grain of the wood, then turns and runs sometimes from one to two feet at right angles. When the cells are completed they are supplied with pollen and separated from each other by sawdust or dust which the bees formed in making the cells, and this dust is glued together with a wax which they supply. When the cells are finished an egg is deposited in each cell; when the egg is hatched the larvae feed on the pollen until they are able to bore their way out of the cell. A Carpenter bee will sometimes use the same home for several hatchings, and the place is often occupied by other bees.

The Stingless bee is sometimes called *Melipona*.

The Honey bee is called *Apis Melifica*.

The leading feature in the natural history of bees, and one which distinguishes them from all other insects is their singular distribution into three different kinds, constituting, to all appearances, so many modifications of sex. The drone, which has a thick body, a round head, a more flattened shape, and a more obtusely terminated abdomen, within which are contained the male organs of generation, is undoubtedly the male of the species. It is distinguished also by the absence of a sting and by the humming noise that accompanies its flight. The queen bee has a sting, has a larger abdomen than the others, and is larger and more graceful. Her work is to lay the eggs for the new colony or generation. The worker bees are small, having a long proboscis, used

for extracting nectar from the flowers, peculiar shaped legs for carrying pollen to be worked into cells or bee-bread, and have only rudimentary generative organs. They construct the interior of the cells, explore the country in search of food and honey, supply the queen, defend the hive, and carry on hostilities against enemies and depredators. The number of workers is much larger than that of the drones, generally not more than one in 30 or 40 is a drone or male, while there is only one developed female or queen. The workers do not present distinctly marked female organs, yet it is now understood that the workers are undeveloped females, and that any worker if taken in the early stages of its development and fed on the proper food can be developed into a queen with all of the sex organs perfect.

How the Bee Stings

The sting consists of a finely pointed tubular instrument open along the whole length of its upper surface. This opening is closed by two horny slender barbs, each having about 10 serrations or notches in its outer edge. These barbs are not projected in advance of the sting as is sometimes supposed, but complete its outer tubular surface down the center of which the poison is injected from a little bag at the root of the sting. The serrations prevent the bee from withdrawing its sting from its enemy, but it is torn from the body with a portion of the intestines, causing the death of the bee. The poison poured into the wound from the sting contains certain pungent salts to which it owes its mischievous tendency.

How They Ventilate the Hive

Crowded into a small space in a box not more than 12 inches square, often with several thousand bees, the air would naturally become foul, and death would result were there not some system of ventilation. These little creatures cannot live in a foul atmosphere any more than could animals of larger size, yet so perfect is their system of ventilation that the air of the hive is little different from the surrounding atmosphere on the out-

side of the hive. This ventilation is effected by the vibration of the wings of a certain number of bees that fasten their feet to the floor of the hive and imitate the action of flying. The vibration of their wings drives the air out of the hive with a current of considerable force, and the fresh air coming in to fill up the vacuum purifies the atmosphere. These bees continue their motions for from 20 minutes to half an hour, when others take their places to be again relieved by others. This is the occasion of that humming sound heard in the hive when the bees are in a state of activity. The immediate cause of the action of ventilation is supposed to be the impression made on the organs or the nervous system by the vitiated air, for a bee can be made to ventilate itself outside the hive if it is brought into contact with substances that have to it an unpleasant odor.

The Bees and the Orchard

Anyone who has studied the subject of the pollenization of flowers, and who knows the important work performed by insects, especially by bees, in fertilizing the orchards, causing the process of germination and the production of fruit, will know that bees are of exceeding importance in fruit growing.

Any student of botany understands that flowers are sexual, and that in order to produce seed or fruit the pollen from the male must be conveyed in some manner to the stigma of the female, and that by the union of the two the process germination begins. But how is this effected? Flowers are fastened by their stems to the limbs on which they grow and cannot mate as do insects and animals. The only possible method, therefore, by which fertilization takes place is that of conveying the pollen grain from the one to the stigma of the other.

There are two classes of flowers, those that are self-pollinating and those that must be cross-pollinated. The self-pollinating flower produces its own pollen, while the cross-pollinating flower must receive the pollen from others, and generally from other trees or plants. There

are two ways in which the pollen can be conveyed from the one to the other. The first is by the wind, which is exceptional, the second is by insects, generally by bees gathering nectar from the flowers. In the process of gathering food the pollen is scattered in minute particles upon the feet, head and organs of the bee, carried from one flower to the other, and deposited where it is suited to the process of germination.

The importance of pollen carrying insects cannot, therefore, be over-estimated. Yet, there is at present a difficulty in the successful keeping of bees that feed upon the nectar from orchard flowers, on account of the fact that the spraying for codling moth must be done after the petals of the flowers have fallen and before the calyx cup closes. At this time the spray should be forced into the calyx cup. If this is done and the bee gets the poison instead of the nectar it dies as surely as the codling moth would die if it entered the calyx cup. We may yet discover an insect that will feed upon the codling moth, and grow it in our orchards, as there have been in many cases discovered insects that feed upon others and destroy them, but until such discovery is made the spraying habit must continue in order to successfully grow fruits, and bee keeping in orchards will be more

or less perilous because thousands of those little creatures will be killed by getting the poison intended for the moth.

At the present time we have no means of knowing how to fertilize our trees except through the aid of insects that carry the pollen, nor have we any knowledge of how to kill the codling moth that so seriously damages the fruit without the use of arsenate of lead or some other poison. However, we believe it profitable, with all the dangers that accompany it, to keep bees in orchards, for while many of them will be killed, many will also survive, and the principal profit will be, not so much in the honey which they produce, as in the fertilization of the trees.

The Sense Perception of Bees

How They Hear, See, Smell, Feel and Taste.—We quote the following from the *Encyclopedia Britannica*:

“The physiology of the sense perceptions in a class of animals of a nature so remote from our own must necessarily be very imperfectly understood by us. The great diversity of character presented by the different tribes of insects, as well as of other animals, naturally suggests the idea that external objects produce on their sentient organs widely different impressions from those communicated to ourselves. The notions that we form of



Fig. 1. A Profitable Colony of Bees in the Yakima Country.
—Courtesy N. P. Ry. Co.

their senses must not only be liable to great inaccuracy, but may often be totally inadequate representations of the truth. A finer organization and more subtle perceptions would alone suffice to extend the sphere of the ordinary senses to an inconceivable degree, as the telescope and the microscope would with our vision. But they possess, in all probability, other organs appropriated to unknown kinds of impressions which must open to them avenues to knowledge of various kinds to which we must ever remain strangers. Art has supplied us with many of the properties of matter which nature has not immediately furnished us with the means of detecting, but who will compare our thermometers, spectroscopes, hygrometers, however elaborately constructed, with those refined instruments with which the lower animals, and particularly insects, are so elaborately provided."

The antennae which is so generally observed in this class of animals, look like horns, and yet are so delicately adjusted that they are believed to be the organs of both feeling and hearing, and are most highly sensitized. They are believed to be sensitive to all the vibrations and changes in the air; they are exceedingly flexible, and may be the organs also of some sense of which we know nothing. Aided by these the bee works in the darkness with perfect accuracy, and builds its comb, pours honey into its magazines, feeds the larvae, and communicates its impressions. With this organ, it speaks a kind of language which seems capable of various modifications, capable of supplying every sort of information of which they are possessed. They have the sense of vision, but during the night they seem guided by a sense located in the antennae; they have the sense of smell, and are attracted by the aroma of the flowers or repelled by disgusting odors or a bad atmosphere. Their perceptions of heat and cold are exceedingly delicate. The influence of the sun's rays excites them to vigorous action; a moderate degree of cold will reduce them to a state of torpor, and even the slight changes from heat to cold are unpleasant to them. Forty degrees of temperature will so be-

numb a bee as to deprive it of the powers of flight. It is this, more than anything else, we believe, that in the Pacific Northwest in the spring of 1911 prevented the pollination of the orchards. For weeks together at the time the blossoms were forming the cold was, for that season of the year, unusually severe, and it was only occasionally that the mercury rose above 40 degrees of temperature. Not being able to work, the bees could not therefore carry the pollen from one tree to another, and many of the trees were not pollinated. In the hive where the bees are in their usual winter quarters they will live in a temperature 20 degrees below zero, and from the condensed vapor in the hive they are often found in a solid lump of ice; yet, with returning spring, they awake to activity. They are exceedingly sensitive to changes in the humidity of the atmosphere, as well as to changes of heat and cold, and can even portend approaching storms when no human sense can detect it. Perhaps the least sensitized of their organs is that of taste. They will extract their food from various things that, from our viewpoint, would be exceedingly disgusting, but otherwise perhaps not more so than many things which we relish.

The Sociology of the Bee

In a colony of bees there are proper divisions of labor, each class doing that to which it is by nature best adapted, and all doing something. There are no useless classes in a hive of bees. It has been said that the drones are parasites and are practically useless because they are not workers. It has been charged against them that they feed on the product of the labor of the workers without rendering a just equivalent for what they receive. This is true only in the sense that the useful period of the drones passes with the fertilization of the queen, and when their work is done it may be said that they are no longer useful. After this work is completed, before entering into winter quarters the drones are cast out of the hive or mercilessly killed. This is perhaps an economic measure, and seems to be performed in order to leave sufficient food to the workers and to the

young. Under conditions where the food is scarce and the question is one of sufficiency for the life of the colony, this habit enables the colony to survive where others would die. Viewed from the standpoint of the class, the killing of the drones or males is unmerciful and unjust; but viewed from consideration of the good of the colony as a whole, the action is justified.

Objection to Bees in Orchards

An objection urged is that they carry blight from tree to tree. This is doubtless true, but the remedy here is, to cut out the blight. I do not conceive it possible to fertilize the flowers without bees, or some other insects which do the work of bees, even though it be true that they are carriers of blight. Some of our best orchardists think that there should be a colony of bees for every 50 trees in an orchard, while others think one colony for 100 trees is sufficient.

GRANVILLE LOWTHER

BEE KEEPING

FRANK BENTON

*In Charge of Apicultural Investigations
United States Department of Agriculture*

Locations Suited to the Keeping of Bees

It may be safely said that any place where farming, gardening, or fruit raising can be successfully followed is adapted to the profitable keeping of bees—in a limited way at least, if not extensively. Many of these localities will support extensive apiaries. In addition to this there are, within the borders of the United States, thousands of good locations for the apiarist—forest, prairie, swamp and mountain regions—where agriculture has as yet not gained a foothold, either because of remoteness from markets or the uninviting character of soil or climate. This pursuit may also be followed in or near towns and, to a limited extent, in large cities. It even happens in some instances that bees in cities or towns find more abundant pasturage than in country locations which are considered fair.

The danger of overstocking a given locality is very frequently exaggerated. Each range, it is self-evident, has a limit. The writer is, however, fully convinced,

after long experience in numerous localities and under the most varied circumstances, that three or four times as many colonies as are commonly considered sufficient to stock a given range may usually be kept with a relative degree of profit. But to secure such results sufficient care and close observation have too frequently not been given in the selection of bees adapted to the locality and conditions.

The Returns to Be Expected from an Apiary

Aside from the pleasure to be derived from the study of these interesting creatures, what returns can one who is well adapted to such work expect to derive?

A moderate estimate for a fairly good locality would be 35 to 40 pounds of extracted honey or 25 pounds of comb honey per colony. This presupposes good wintering and an average season. By locating in some section particularly favorable to apiculture—that is, near large linden forests, with clover fields within range, supplemented by buckwheat; or in a section where alfalfa is raised for seed; where mesquite, California sages and wild buckwheat abound; where mangrove, palmettoes and titi, or where sourwood, tuliptree, and asters are plentiful—these returns may frequently be doubled or trebled. But these favored locations, like all others, are also subject to reverses—the result of droughts, great wet, freezes which kill back the bee pasturage, etc. On the whole, there should be expected from the raising of bees for any purpose whatever only fair pay for one's time, good interest on the money invested, and a sufficient margin to cover contingencies. With no greater expectations from it than this, and where intelligence directs the work, apiculture will be found, in the long run, to rank among the best and safest of rural industries.

The value of bees in the pollination of various fruit and seed crops is often sufficient reason to warrant the keeping of a small apiary, even if circumstances do not favor its management in such a manner as to secure the largest possible crops of honey or to insure the saving of all swarms.

Anyone Who Desires to Do So Can Learn to Manipulate Bees

Any person with fairly steady nerves and some patience and courage can easily learn to control and manipulate bees. There are, it is true, a few exceptional individuals whose systems are particularly susceptible to the poison injected by the bee, so much so that serious effects follow a single sting. Such cases are, however, very rare. In most instances where care is not taken to avoid all stings the system eventually becomes accustomed to the poison, so that beyond momentary pain a sting causes no inconvenience.

How to Avoid Stings

Stings can be avoided, first, by having gentle bees. If no other point of superiority over the common brown or black bee than that of gentleness could be fairly claimed for some of the races introduced and some of the strains developed in recent years, it would still be worth while to get them on this account alone. When the fact of superiority in several other important points is considered also, there should be no further question as to the advisability of procuring them in preference to the common variety.

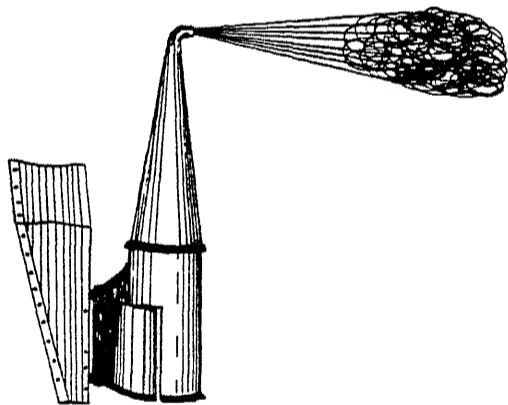

Fig 1 The Bingham Bee Smoker.

Of the races already in general cultivation, Carniolans are the gentlest, although Caucasians, more recently introduced from Southeastern Russia and only now being put on sale, are by far the least inclined to sting of any bees, and may be handled at all times without resorting to the protection of a bee veil, and generally without smoke, or at most, a very slight application of smoke. Some strains of Italians equal in gentleness average Car-

niolans, but in general the race native to Italy is by no means as gentle as that found in Carniola, Austria, and the Caucasians are much to be preferred for the beginner. In case these gentler races are not easily procurable he need not hesitate, however, to undertake, after adopting due precautions, the manipulation of pure Italians.

In crossing well-established breeds the males of a gentle race should be used,

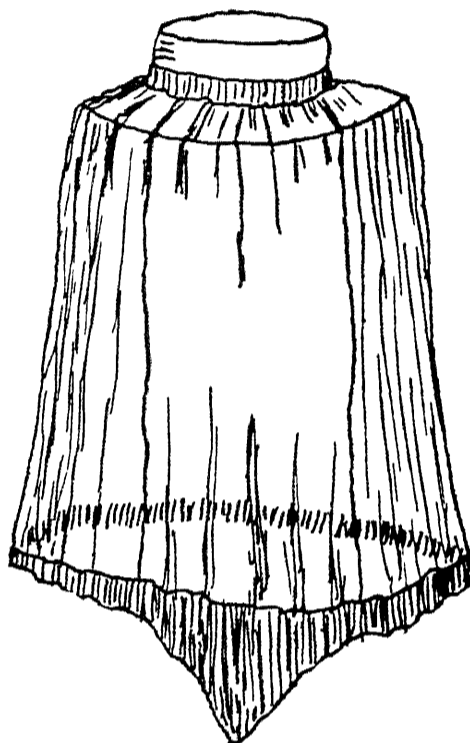

Fig 2. Bee Veil.

otherwise the workers of the cross may vary greatly in temper, especially in the first few generations. Only careful selection continued for some time will so fix the desirable traits as to result in their reproduction with a fair degree of certainty in the offspring. Bees having the blood of blacks and Italians are nearly always quite vicious in the case of the first cross, and are even harder to subdue with smoke than are pure blacks. Other races need not be considered here, as they are adapted to special purposes; and the skill of the bee master, the conditions of climate, flora, etc., and the particular line of production to be followed, should decide whether their introduction is advisable or not.*

* For a fuller discussion of this subject, see "The Honey Bee: A Manual of Instruction in Apiculture," by Frank Benton, M. S. Bulletin No. 1, new series, Bureau of Entomology, U. S. Department of Agriculture, third edition, 1899, Chapter I, pp. 11-18.

The second essential to enable one to avoid stings is to have a good smoker at hand whenever the bees are to be handled. For ease and effectiveness in keeping bees under control nothing will take the place of the modern bellows smoker (Fig. 1). A good one lasts years, and its cost is so slight (\$1 to \$1.25 for the medium sizes) that the expenditure may be considered one of the wisest that can be made in fitting up an apiary.

A veil (Fig. 2), made of black bobinet or Brussels net, to draw over the hat, and a pair of gloves, preferably of rubber, may be used. The veil can be safely dispensed with if the gentlest bees are kept.

Simple and convenient hives, employing the Langstroth principle, and with stories and frames interchangeable and so constructed as to reduce propolization to a minimum and to insure straight combs, will much facilitate the avoidance of stings.

The use of the bee escape (Fig. 3) in

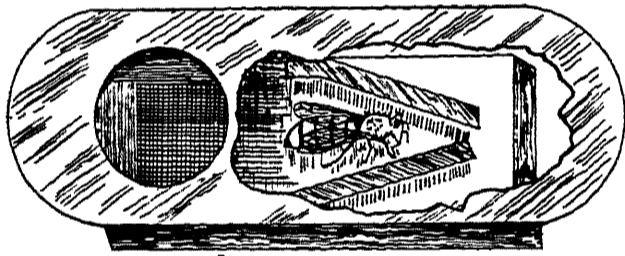

Fig. 3. The Porter Spring Bee Escape removing surplus honey greatly reduces the risk of being stung during this operation, for it saves much manipulation of combs and shaking and brushing of bees. This useful device is fitted into a slot made in a board the same size as the top of the hive, and the whole, when slipped in between the brood apartment and an upper story or super, will permit all of the workers above to go down into the lower story but not to return to the top one, so that in one night it is possible to free entirely a set of combs from bees without any manipulation of the combs, and without smoking, shaking or brushing the bees.

What Race of Bees to Choose

As the gentler races are excellent honey gatherers the beginner should adopt only these—either Caucasians, Carniolans, or Italians. Should full colonies not be ob-

tainable, colonies of ordinary bees may be changed by replacing their queens with queens of the desired race, the latter having been procured in small boxes by mail.

A brief summary of the leading traits of the various races now in this country will be of use in guiding the purchaser.

Caucasians are natives of Southern Russia, are exceedingly gentle, good workers, good defenders of their hives, prolific, build many queen cells, and swarm often if confined to small hives. The workers are dark leaden gray in their general color, and present quite a ringed appearance because of the alternation of this dark color with the lighter fuzz which edges the segments of the abdomen.

Carniolans are much larger bodied and somewhat lighter gray in color than the Caucasians. Their great hardiness and excellent wing power enable them to fly freely in much cooler weather than some other races stand, and to regain their hive entrances under adverse conditions. They are prolific, active, and good honey gatherers, producing combs of snowy whiteness.

Italians, the first of the foreign races to be introduced into this country, are much more widely known, and have with reason found great favor, since they are industrious, good defenders of their hives, and excellent honey gatherers, as well as handsome in appearance, being usually evenly marked with three yellow bands across the anterior portion of the abdomen.

Cyprians, from the island of Cyprus, may be taken as a general type with which to compare other Eastern races. They are small bodied, more slender, in fact, than any of the European races of bees. The abdomen is more pointed and shows, when the bees are purely bred, three light-colored bands on the upper surface, and considerable yellow on the under side. Cyprians possess longer tongues and greater wing power than other races. This, combined with great prolificness and most remarkable activity, renders them the best of honey gatherers. In temper, however, they may be regarded as rather aggressive, rendering

their management by any who are not experts extremely difficult.

Cyprio-Carniolans and Cyprio-Caucasians—Bees combining the blood of the first two races in various proportions have been tested for years in comparison with all other known races, with the result that the cross mentioned above has been found to exceed all of the pure races in honey-gathering powers, owing undoubtedly to the combination of great energy, hardiness, prolificness, and wing-power, as well as greater length of tongue—a fact established by actual measurements. Similar results, with even greater gentleness, may be expected from the cross obtained between Cyprian queens and Caucasian drones.

Syrian and Palestine or "Holy-Land" Bees.—What has been said of Cyprians may be taken to apply in a general sense to Syrian and Palestine bees, except that in these the good qualities are slightly less prominent, while some of the bad ones of the Cyprians are accentuated

German, Common Black, or Brown Bees.—The bees commonly found wild, and cultivated to a greater or less extent, in this country, and known under the above name, are probably derived from early introductions from the Old World. In comparison with the races above enumerated, they may be said to be inferior, since they possess the least energy in honey collecting, are less prolific, and not as good defenders of their hives. Under favorable conditions, however, as regards pasturage they may be relied upon for excellent results. They are, however, spiteful under manipulation, and have the disagreeable habit of running from the combs and dropping in bunches on the ground, likewise or flying from the hive entrance and attacking passers-by. They are more easily discouraged than other bees during slack times as regards honey production, and this is doubtless the main reason for their generally inferior economic value.

What Hive to Adopt

The suspended Langstroth frame is used more than any other frame among English-speaking bee keepers. There being

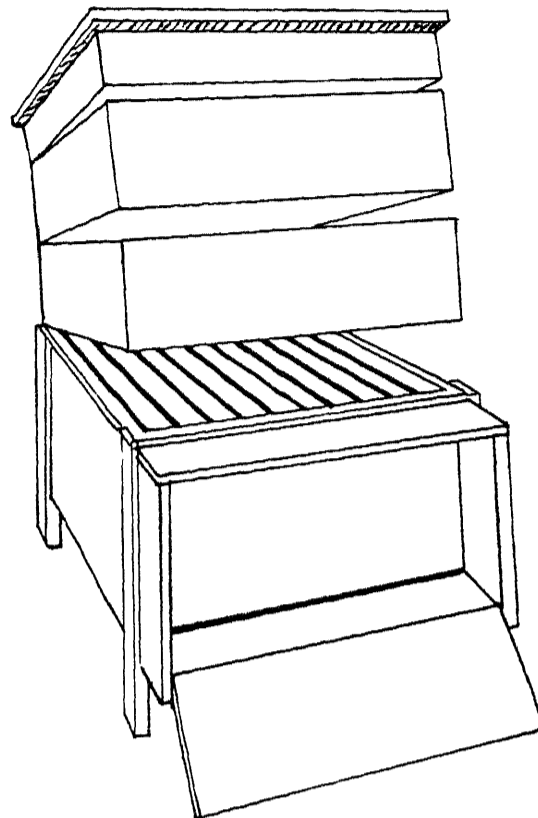

Fig 4 Langstroth Hive with Two Half-depth Supers for Surplus Honey.

no patent on the Langstroth hive, and accurately made hives being obtainable at moderate prices from hive factories in various parts of the country, it is taken for granted that the enterprising beginner will adopt a simple form embodying this principle—the loose-fitting, suspended comb frame—as its main feature. The hive should not only be substantially built, but should have accurate bee spaces and a close-fitting, rainproof cover or roof. Factory-made hives, as a rule, best meet these requirements, as both lock joints and halved corners can only be made to advantage by machinery, and the expert hive builder understands, of course, the absolute necessity of great accuracy in bee spaces, as well as the great desirability of good material and workmanship. Provision should also be made for winter protection.

For comb honey, hives permitting the insertion in the brood apartment of any number of frames up to eight, or frequently up to ten, are most in use. In securing extracted honey, those with ten to 12 frames in each story are preferable, and as many stories, one above the other, are employed as the strength of the colony and a given harvest may require. A construction, therefore, which readily ad-

mits of expansion and of contraction, as occasion demands, is desirable.

Mention should be made of a hive of quite different construction, a prominent feature of which is this ease of contraction and expansion. It is the last hive which the late M. Quinby gave to the public—the Quinby closed-end frame hive. This hive is used with great success by certain American bee keepers of long experience and whose apiaries are among the largest in the world.

Management in Swarming

Natural Swarming

When a swarm is seen issuing or in the air, the best thing to do is, in general, simply to wait a bit. The weather is usually rather warm then, and rushing about to get tin pans, dinner gongs, spraying outfits, etc., aside from its disagreeableness, may get one so excited and into such a perspiration as to unfit him to do with the bees that which is likely to be necessary a few minutes later. The bees will probably gather in a clump on a tree or bush near the apiary and however formidable getting them into the hive may at first seem, nothing will be simpler than shaking them into their new hive, or into a basket or box, from which they may be poured in front of the hive, just as one would pour out a measure of wheat or beans.

The securing of swarms can be made, however, even simpler than this by having the colonies placed several feet apart on a smooth lawn or dooryard and clipping one wing of each laying queen so as to prevent her flying. The prime or first swarm from each hive is accompanied by the old queen, and if she be clipped she will of course fall from the alighting board to the ground and may be secured in a cage.

The parent colony removed to a new stand a rod or more away will rarely give a second swarm. But to make certain all queen cells except one may be cut out four or five days after the issuance of the first swarm.

Each after-swarm (second, third, etc.), it should be borne in mind, is accompanied by one or more unimpregnated

queens, and these must not be clipped until they have flown out and mated. The regular deposition of eggs in worker cells may nearly always be regarded as a safe sign that mating has taken place. Eggs will usually be found in such cells within the first ten days of the queen's life.

Prevention of Swarming

Under the conditions most frequently occurring—that is, where it is not practicable to be present at all times during the swarming season, or where the desired number of colonies has been attained—a system of management is advisable which in general contemplates the prevention, insofar as possible, of the issuance of swarms without at the same time interfering with honey storing. The paragraphs following on this subject are taken from the department publication, "The Honey Bee."

The most commonly practiced and easily applied preventive measure is that of giving abundant room for storage of honey. This to be effective should be given early in the season, before the bees get fairly into the swarming notion, and the honey should be removed frequently, unless additional empty combs can be given in the case of colonies managed for extracted honey, while those storing in sections should be given additional supers before those already on are completed. With colonies run for comb honey it is not so easy to keep down swarming as in those run for extracted honey and kept supplied with empty comb. Free ventilation and shading of the hives as soon as warm days come will also tend toward prevention. Opening the hives once or twice weekly and destroying all queen cells that have been commenced will check swarming for a time in many instances, and is a plan which seems very thorough and the most plausible of any to beginners. But sometimes swarms issue without waiting to form cells; it is also very difficult to find all cells without shaking the bees from each comb in succession, an operation which, besides consuming much time, is very laborious when supers have to be removed, and greatly disturbs the labors of the bees.

If but one cell is overlooked the colony will still swarm. The plan therefore leaves at best much to be desired, and is in general not worth the effort it costs and can not be depended on.

Dequeening—The removal of a queen at the opening of a swarming season interferes, of course, with the plans of the bees, and they will then delay swarming until they get a young queen. But to prevent swarming by keeping colonies queenless longer than a few days at most is to attain a certain desired result at a disproportionate cost. The plan is therefore not to be commended.

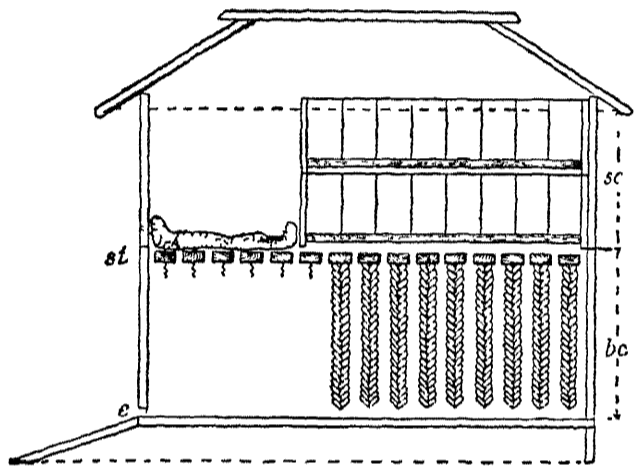

Fig. 5. The Simmins Nonswarming System—Single-story Hive with Supers bc, brood chamber; sc, supers; st, starters of foundation; e, entrance.

Requeening.—Quite the opposite of this and more efficacious in the prevention of swarming, is the practice of replacing the old queen early in the season with a young one of the same season's raising, produced, perhaps, in the South before it is possible to rear queens in the North. Such queens are not likely to swarm during the first season, and, as they are vigorous layers, the hive will be well populated at all times and thus ready for any harvest. This is important, inasmuch as a flow of honey may come unexpectedly from some plant ordinarily not counted upon; and also, since the conditions essential to the development of the various honey-yielding plants differ greatly, their time and succession of honey yield will also differ with the season the same as the quantity may vary. Young queens are also safest to head the colonies for the

winter. The plan is conducive to the highest prosperity of the colonies, and is consistent with the securing of the largest average yield of honey, since, besides giving them vigorous layers, it generally keeps the population together in powerful colonies. It is therefore to be commended on all accounts as being in line with the most progressive management, without at the same time interfering with the application of other preventive measures.

Space Near Entrances.—Arranging frames with starters, or combs merely begun, between the brood nest and the flight hole of the hive, while the bees are given storing space above or back of the brood nest (Fig. 5), is a plan strongly recommended by Samuel Simmins, of England, and which has come to be known as "the Simmins non-swarming method," some features of it and the combination into a well-defined method having been original with him. It is an excellent preventive measure, though not invariably successful, even when the distinctive features brought forward prominently by Mr. Simmins—empty space between the brood combs and entrance, together with the employment of drawn combs in the supers—are supplemented by other measures already mentioned; but when, in addition to the space between the brood and the flight hole, the precaution be taken to get supers on in time, to ventilate the hive well, and to keep queens not over two years old, swarming will be very limited. If to these precautions be added that of substituting for the old queens young ones of the current season's raising, before swarming has begun, practical immunity from swarming is generally insured.

Selection in Breeding.—Some races of bees show greater inclination than others toward swarming, and the same difference can be noted between individual colonies of a given race; therefore, whatever methods be adopted to prevent or limit increase, no doubt the constant selection of those queens to breed from whose workers show the least tendency toward swarming would in time greatly reduce this disposition.

Economic Plants and Trees for Cultivation for Honey and Pollen

Except as a means of bridging over gaps in the natural pasturage, special crops for honey alone are not profitable, but where other utilities besides that of honey yield can be combined with it, there is some advantage to be gained.

Filbert Bushes.—Useful for wind breaks and for their nuts, yield pollen in February and March.

Rape.—Can be grown successfully in the North for pasturage, for green manuring, or for seed, and when permitted to blossom yields considerable pollen and honey. Winter varieties are sown late in the summer or early in the autumn, and blossom in April or May following. This early yield forms an excellent stimulus to brood rearing. Summer or bird rape, grown chiefly for its seed, blossoms about a month after sowing. It does best during the cooler months of the growing season.

Russian or Hairy Vetch.—Is a hardy leguminous plant of great value for forage and use in green manuring. The blossoms appear early in the season, and, where there is any lack in early pollen, especially in northern and cool regions, this vetch will be found of great value to the bees.

Fruit Blossoms.—Apricot, peach, pear, plum, cherry, apple, currant, and gooseberry, yield pollen and honey in abundance during April or May; strawberry and blackberry are sometimes visited freely by bees, but are generally far less important than the others mentioned. Colonies that have wintered well often gather during apple bloom 12 to 15 pounds of surplus honey of fine quality. The raspberry secretes a large amount of nectar of superb quality, and coming in May or June, thus later than the other fruit blossoms and when the colonies are stronger and the weather is more settled, full advantage can nearly always be taken of this yield. Grape and persimmon blossom also in June; the latter is an excellent source. In subtropical portions of the country orange and lemon trees yield fine honey in March and April, and the

cultivation of the banana has added a profuse honey yielder which puts forth successive blossoms all through the summer months.

Locust, Tulip Tree ("poplar," or white-wood), and *Horse-Chestnut.*—Useful for shade, ornament, and timber, are all fine honey producers in May. The locust yields light-colored, clear honey of fine quality, the others amber-colored honey of good body and fair flavor.

Clovers.—Crimson, blossoming in April or May, yields fine, light-colored honey; white, alsike, and mammoth or medium, blossoming in May, June, and July, give honey of excellent quality and rich yellow color.

Mustard.—Grown for seed flowers from June to August. The honey is somewhat acrid and crystallizes soon, yet the plant, where abundant, is of much importance to the bees and the bee keeper in case other forage is scant at the time.

Asparagus.—Blossoms are much visited by bees in June and July.

Esparcet, or Sainfoin.—Yields in May and June fine honey, almost as clear as spring water. It is a perennial leguminous plant, rather hardy, an excellent forage crop, and particularly valuable for milch cows. It succeeds best on a limestone soil or when lime is used as a fertilizer, and is itself an excellent green manure for soils deficient in nitrogen and phosphoric acid.

Sulla, or Sulla Clover.—A perennial plant, closely related to esparcet or sainfoin, succeeds, like the latter, best upon limestone soil or when fertilized with lime. It yields a splendid quality of honey from beautiful pink blossoms, which continue during May and June. The plant is an excellent soil fertilizer and of great value in connection with the feeding of stock, particularly dairy animals. It is, however, much less hardy than esparcet, and success with it can therefore hardly be looked for above the latitude of North Carolina and Arkansas. When the qualities and requirements of this plant were brought by the writer to the notice of a prominent scientific agriculturist of the South, this gentleman

suggested as very probable that the black belt of Alabama, Mississippi, Louisiana, and Texas would be well adapted to it, the lands of this region being exceedingly strong in lime. In portions of Southern Europe sulla clover is a most important forage crop for farm stock as well as for honey bees.

Serradella.—Is an annual leguminous plant which will grow on sandy land, and which yields, besides good forage, clear honey of good quality in June and July.

Chestnut.—Valuable for timber, ornament, shade, and nuts, yields honey and pollen in June or July.

Linden, Sourwood, and Catalpa.—Fine shade, ornamental, and timber trees, yield great quantities of first quality honey in June and July.

Cotton.—In the South cotton blossoms, appearing as they do in succession during the whole summer, often yield considerable honey. It would appear, however, that when the plants are very rank in growth the blossoms—being correspondently large—are too deep for the bees to reach the nectar.

Chicory.—Raised for salad and for its roots, is, whenever permitted to blossom, eagerly visited for honey in July and August.

Sweet, Medicinal, and Pot Herbs.—Such as marjoram, savory, lavender, catnip, balm, sage, thyme, etc., when allowed to blossom, nearly all yield honey in June, July, or August. Where fields of them are grown for the seed the honey yield may be considerable from this source.

Alfalfa.—Furnishes in the West a large amount of very fine honey during June and July. Its importance there as a forage crop is well known, but how far eastward its cultivation may be profitably extended is still a question, and even should it prove of value in the East as a forage plant, its honey-producing qualities there would be still uncertain.

Parsnips.—When left for seed, blossom freely from June to August, inclusive, and are much frequented by honey bees.

Peppermint.—Raised for its foliage, from which oil is distilled, is most fre-

quently cut before the bees derive much benefit from it, but whenever allowed to blossom it is eagerly sought after by them, and yields honey freely during July and August.

Bokhara, or Sweet Clover.—Is in some sections of the country considered a valuable forage crop. Animals can be taught to like it, and it is very valuable as a restorer of exhausted lime soils, while in regions lacking in bee pasturage during the summer months it is a very important addition. It withstands drought remarkably well and yields a large quantity of fine honey.

Cucumber, Squash, Pumpkin and Melon.—Blossoms furnish honey and some pollen to the bees in July and August.

Eucalypti.—Valuable for their timber and as ornaments to lawn and roadside, are quick-growing trees adapted to the southern portions of the United States. They yield much honey between July and October.

Carob Tree.—The cultivation of which has been commenced in the Southwest, is an excellent honey yielder in late summer. It is an ornamental tree and gives, in addition to honey, another valuable product—the carob bean of commerce.

Sacaline.—A forage and ornamental plant of recent introduction, is a great favorite with bees. It blossoms profusely during August, is a hardy perennial, and thrives in wet and also fairly in dry situations, withstanding the ordinary summer drought of the Eastern states because of its deeply penetrating roots.

Buckwheat.—Is an important honey and pollen producer. Its blossoms appear about four weeks after the seed is sown, hence it may be made to fill in a summer dearth of honey plants.

How to Obtain Surplus Honey and Wax

Good wintering, followed by careful conservation of the natural warmth of the colony, the presence of a prolific queen—preferably a young one—with abundant stores for brood rearing, are, together with the prevention, in so far as possible, of swarming, the prime conditions necessary to bring a colony of

bees to the chief honey flow in shape to enable it to take full advantage of the harvest.

Extracted Honey

To secure extracted honey, the requisite number of combs may be in one long hive, or in stories one above another. If numerous sets of combs are at hand, or if it is desirable to have others built, additional stories are put on as fast as the combs already occupied by the bees are filled. Before removing the filled combs time should be allowed the bees to ripen and cap the honey; hence enough combs are necessary to give the bees storage room while they are capping others. The honey in combs that are quite or nearly sealed over may be considered sufficiently ripened to be removed from the hive.

It should also be taken promptly, in order to keep the various grades or kinds separate.

The cells are uncapped by means of a sharp knife, made especially for this purpose (Fig. 6), and the combs are then

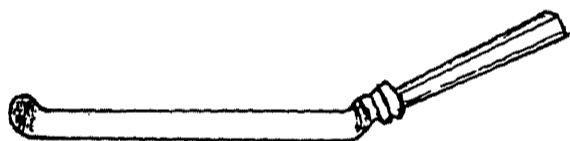

Fig. 6. Quinby Uncapping Knife.

made to revolve rapidly in the honey extractor. The centrifugal force exerted on the honey throws it out, leaving the comb cells uninjured, or so slightly injured that they are wholly repaired within an hour or so after the return of the comb to the hive. The chief advantages of this method of harvesting over that of crushing the combs are at once apparent when it is known that each pound of comb saved represents several pounds of honey (consumed in its construction), and may, with care be used over almost indefinitely in securing surplus honey. Furthermore, extracted honey is of much finer quality than that obtained by crushing the combs and straining out the liquid part, since it is free from crushed bees, larvae, pollen or "bee bread," etc., which not only render strained honey dark and strong in flavor, but also make it liable to fermentation and souring.

The extracted honey is run into open

buckets or tanks and left, covered with cheese cloth, to stand a week or so in a dry, warm room not frequented by ants. It should be skimmed each day until perfectly clear, and is then ready to be put into cans or barrels for marketing, or to be stored in a dry place.

The surplus combs are to be removed at the close of the season and hung an inch or so apart on racks placed in a dry, airy room, where no artificial heat is felt. Moth larvae are not likely to trouble them until the following spring, but upon the appearance of milder weather their ravages will begin, and if the combs cannot be placed under the care of the bees at once they must be fumigated with burning sulphur or with bisulphid of carbon.

Comb Honey

The main difference to be observed in preparing colonies for the production of comb honey, instead of extracted, is in the adjustment of the brood apartment at the time the supers are added. After the colony has been bred up to the greatest possible strength, the brood apartment should be so regulated in size, when the honey flow begins and the supers are added, as to crowd many of the bees out and into the supers placed above.

On each hive a super is placed holding 24 to 48 sections, each section supplied with a strip or a full sheet of very thin foundation. It is best not to give too much space at once, as considerable warmth is necessary to enable the bees to draw out foundation or to build comb. A single set of sections is usually sufficient at a time. When the honey is designed for home use or for a local market, half-depth frames are sometimes used, the same as those often used above the brood nests when colonies are run for extracted honey, but for the general market pound sections are better adapted.

It is the practice of many to have nice white comb partially drawn out before the main honey flow begins, or even the season before, feeding the colonies, if necessary, to secure this; and, when the honey yield begins, to supply sets of sections with these combs having cells deep

enough for the bees to begin storing in as soon as any honey is collected. Earlier work in the sections is thus secured, and this, as is well known, is an important point in the prevention of swarming. Samuel Simmins, of England, has long contended for this use of partially drawn combs, and though it forms a feature of his system for the prevention of swarming it has been too often overlooked. Comb foundation is now manufactured with extra thin septum or base and with the beginnings of the cells marked out by somewhat thicker walls which the bees immediately thin down, using the extra wax in deepening the cells. This is not artificial comb, but a thin sheet of wax having the bases of the cells outlined on it. Complete artificial combs have never been used in a commercial way, although there exists a widespread belief to this effect, which is founded on extravagant claims that have appeared from time to time in newspaper articles.

If the brood apartment has been much contracted when the supers were added, the queen may go into the sections and deposit eggs unless prevented by the insertion of a queen excluder (Fig. 7).

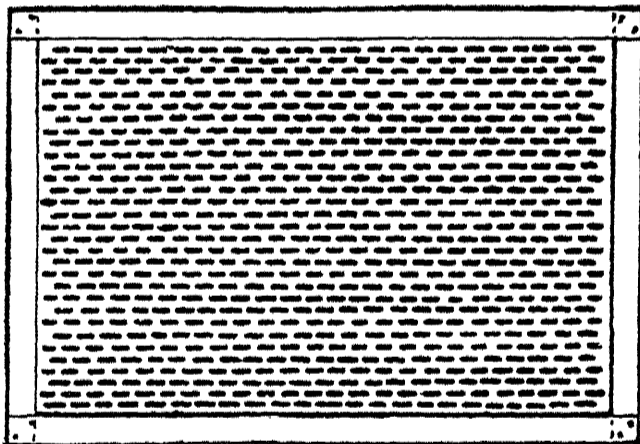

Fig. 7. Perforated Zinc Queen Excluder.

This, merely a sheet of zinc with perforations which permit workers, but not the queen, to pass, is placed between the brood apartment and the supers. The great inconvenience of having brood in some of the sections is thereby prevented. When the honey in the sections has been nearly capped over, the super may be lifted up and another added between it and the brood apartment. Or, should

the strength of the colony not be sufficient, or the harvest not abundant enough to warrant the giving of so much space, the sections which are completely finished may be removed and the partly finished ones used as "bait sections" to encourage work in another set of sections on this hive or in new supers elsewhere. The objections to the removal of sections one by one, and brushing the bees from them, are (1) the time it takes, and (2) the danger that the bees when disturbed, and especially if smoked, will bite open the capping and begin the removal of the honey, thus injuring the appearance of the completed sections.

A recent valuable invention, the bee escape, when placed between the super and the brood nest, permits the bees then above the escape to go down into the brood apartment, but does not permit their re-entering the super. If inserted 12 to 24 hours before the sections are to be removed, the latter will be found free from bees at the time of removal, provided all brood has been kept out of the supers.

Grading and Shipping Comb Honey

Before marketing the honey it should be carefully graded, and all propolis ("bee-glue"), if there be any, scraped from the edges of the sections. In grading for the city markets the following rules are, in the main, observed. They were adopted by the North American Bee Keepers' Association at its twenty-third annual convention, held in Washington, D. C., in December, 1892, and are copied from the official report of that meeting:

Fancy.—All sections to be well filled; combs straight, of even thickness, and firmly attached to all four sides; both wood and comb unsoiled by travel stain or otherwise; all cells sealed except the row of cells next to the wood.

No. 1.—All sections well filled, but with combs crooked or uneven, detached at the bottom, or with but few cells unsealed; both wood and comb unsoiled by travel stain or otherwise.

In addition to the above, honey is to be classified, according to color, into light,

amber, and dark. For instance, there will be "fancy light," "fancy amber," and "fancy dark," "No. 1 light," "No. 1 amber," and "No. 1 dark."

The sections, after grading and scraping, are to be placed in clean shipping cases having glass in one or both ends. Several of these may be placed in a single crate for shipment. To prevent breaking down of the combs it is best to put straw in the bottom of the crate for the shipping cases to rest on, and the crates should be so placed as to keep the combs in a perpendicular position. The crates are also likely to be kept right side up if convenient handles are attached to the sides—preferably strips with the ends projecting beyond the corners. Care in handling will generally be given if the glass in the shipping cases shows.

Production of Wax

No method has yet been brought forward which will enable one, at the present relative prices of honey and wax, to turn the whole working force of the bees,

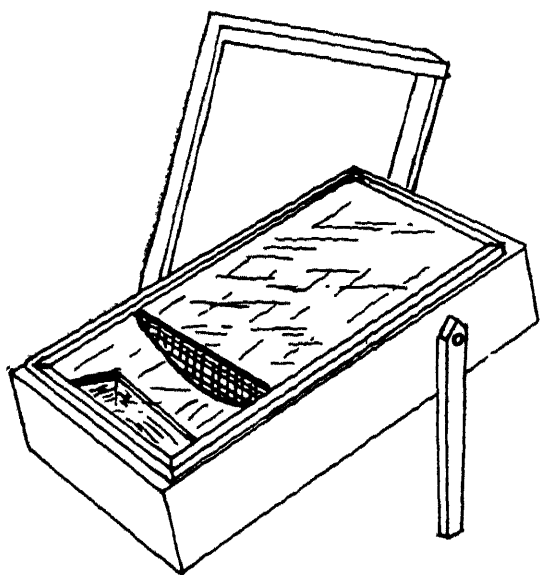

Fig. 8. Solar Wax Extractor.

or even the greater part of it, into the production of wax instead of honey; in fact, the small amount of wax produced incidentally in apiaries managed for extracted or for section honey is usually turned into honey the following season; that is, it is made into comb foundation, which is then employed in the same hives to increase their yield of marketable honey. It is even the case that in most apiaries managed on approved modern methods more pounds of foundation are

employed than wax produced; hence less progressive bee keepers—those who adhere to the use of box hives and who can not therefore utilize comb foundation—are called upon for their wax product. As each pound of wax represents several pounds of honey, all cappings removed when preparing combs for the extractor, all scrapings and trimmings and bits of drone comb, are to be saved and rendered into wax. This is best done in the solar wax extractor (Fig. 8), the essential parts of which are a metal tank with wire-cloth strainer and a glass cover, the latter generally made double. The bottom of the metal tank is strewn with pieces of comb, the glass cover adjusted, and the whole exposed to the direct rays of the sun. A superior quality of wax filters through the strainer.

The Wintering of Bees

How to bring bees successfully through the winter in the colder portions of the United States is a problem which gives anxiety to all who are about to attempt it for the first time in those sections, and even many who have kept bees for years still find it their greatest difficulty. A queen may die and the colony dwindle away. But care as to ventilation, dampness, age of the bees, etc., will usually insure a successful wintering. Out-of-door wintering is to be preferred where the climate is not too severe.

General Considerations

Whatever method be followed in wintering, certain conditions regarding the colony itself are plainly essential: First, it should have a good queen; second, a fair-sized cluster of healthy bees, neither too old nor too young; third, a plentiful supply of good food. The first of these conditions may be counted as fulfilled if the queen at the head of the colony is not more than two years old, is still active, and has always kept her colony populous; yet a younger queen—even one of the current season's rearing, and thus but a few weeks or months old—is, if raised under favorable conditions, much to be preferred. The second point is met if brood rearing has been continued with-

out serious interruption during the latter part of the summer and the cluster of bees occupies, on a cool day in autumn, six to eight or more spaces between the combs, or forms a compact cluster eight or ten inches in diameter. Young bees, if not well protected by older ones, succumb readily to the cold, while quite old bees die early in the spring, and others, which emerged late in the summer or autumn preceding, are needed to replace them. The third essential—good food—is secured if the hive is liberally supplied with well-ripened honey from any source whatever, or with fairly thick syrup, made from white cane sugar, which was fed early enough to enable the bees to seal it over before they ceased flying. The syrup is prepared by dissolving three pounds of granulated sugar in one quart of boiling water and adding to this one pound of pure extracted honey. Twenty to 25 pounds for outdoor wintering in the South, up to 30 or 40 pounds in the North, when wintered outside with but slight protection—or, if wintered indoors, about 20 pounds—may be considered a fair supply of winter food.

Indoor Wintering

A dry, dark cellar or special repository built in a sidehill or with double, filled walls, like those of an icehouse, may be utilized for wintering bees in extremely cold climates. It should be so built that a temperature of 42 to 45 degrees Fahrenheit (the air being fairly dry in the cellar) can be maintained during the greater part of the winter. To this end it should be well drained, furnished with adjustable ventilators, and covered all over with earth, except the entrance, where close-fitting doors, preferably three of them, should open in succession, so as to separate the main room from the outside by a double entry way. The colonies, supplied with good queens, plenty of bees, 20 to 25 pounds of stores each, and with chaff cushions placed over the frames, are carried in shortly before snow and severe freezing weather come.

Any repository which is damp or one whose temperature falls below freezing or remains long below 38 degrees Fahren-

heit is not a suitable place in which to winter bees. When in repositories, the bees have no opportunity for a cleansing flight, nor do they, when the temperature rises outside, always warm up sufficiently to enable the cluster to move from combs from which the stores have been exhausted to full ones, hence in a cold repository they may possibly starve with plenty of food in the hive. As a rule, colonies would be better off out of doors on their summer stands than in such places.

Outdoor Wintering

Cold and dampness are the great winter enemies of bee life. A single bee can withstand very little cold, but a good cluster, if all other conditions are favorable, can defy the most rigorous winters of our coldest states. But if not thoroughly dry, even a moderate degree of cold is always injurious, if not absolutely fatal. Dampness in winter is therefore the most dangerous element with which the bee keeper has to contend. The matter would, of course, be quite simple if only that dampness which might come from the outside were to be considered, but when the air of the hive, somewhat warmed by the bees and more or less charged with the moisture of respiration, comes in contact with hive walls or comb surfaces made cold by outside air, condensation takes place, and the moisture trickles over the cold surfaces and cluster of bees, saturating the air about them or even drenching them, unless by forming a very compact cluster they are able to prevent it from penetrating, or by greater activity to raise the temperature sufficiently to evaporate the surplus moisture, or at least that portion near them. But this greater activity is, of course, at the expense of muscular power and requires the consumption of nitrogenous as well as carbonaceous food. Increased cold or its long continuance greatly aggravates conditions.

Nature has provided that the accumulation of waste products in the body of the bee during its winter confinement should be small under normal conditions, but unusual consumption of food, especially of a highly nitrogenous nature like pollen,

necessitates a cleansing flight, or diarrheal difficulties ensue, combs and hives are soiled, the air of the hive becomes polluted, and at last the individual bees become too weak to generate proper warmth or drive off the surplus moisture which then invades the cluster and brings death to the colony; or, what is more frequently the case, a cold snap destroys the last remnant of the colony, which has been reduced by constant loss of bees impelled by disease to leave the cluster or even to venture out for a cleansing flight when snows and great cold prevail.

The problem then is: *To retain the warmth generated by the bees, which is necessary to their well-being, and at the same time to prevent the accumulation of moisture in the hive.* A simple opening at the top of the hive would permit much of the moisture to pass off, but of course heat would escape with it and a draft would be produced. Absorbent material about the cluster creates, without free ventilation, damp surroundings, and again the temperature is lowered. It is only necessary, however, to surround the bees with sufficient material to protect them fully against the greatest cold likely to occur, and to take care also that this enveloping material is of such a nature and so disposed as to permit the free passage of the moisture which would otherwise collect in the interior of the hive, and to permit the escape into the surrounding atmosphere of such moisture as enters this material from within. This packing should also be fully protected from outside moisture.

South of Virginia, Kentucky, and Kansas single-walled hives may be employed in most localities with good success in outdoor wintering. On the approach of the cool or the rainy season a close-fitting quilt should be laid over the frames and several folded newspapers pressed down on this, or a cushion filled with dry chaff or some other soft material may be used instead of paper. The cover or roof should be absolutely rainproof, yet between this cover and the cushion or papers should be several inches of space

with free circulation of air. In order to permit this ventilation above the top packing, the cover should not rest upon the cap or upper story all of the way around, or if it does, an auger hole in each end, protected by wire cloth against the entrance of mice, should give free passage to the air. In the more northern portion of the section referred to some further protection is advisable, and is really necessary in the mountainous parts of the same territory if the best results are to be obtained. Farther north, and especially in the cold Northwest, much greater protection becomes an absolute necessity. Quilts with newspapers or thin packing above do not alone suffice. The side walls of the hive may be made of pressed straw. These, with top packing, if kept dry outside, are excellent for outdoor wintering, even in climates so cold that ordinary wooden hives do not afford sufficient protection.

In the severest climates, however, still greater protection on all sides of the colony is needed, and packing with chaff or other soft material is decidedly the best plan. The thickness of this surrounding packing should be from two inches to eight or ten inches for single colonies, according to the severity of the climate, but if four or more colonies are grouped for the winter, so as to make the natural warmth generated mutually advantageous, somewhat less packing will be sufficient. A most important point is to have the soft warmth-retaining packing come in close contact with the edges of the combs, and above all *not to have a hive wall, either thick or thin, between this material and the bees.* A good plan is to construct an open framework or skeleton hive of laths, cover it with sack-ing, or, preferably, some less fuzzy cloth which the bees will not gnaw, and after placing it in an outer wooden case large enough every way to admit of the necessary packing about the colony, to fill in on all sides with some dry, porous material. If the frames are shallow, like the Langstroth, it is better to construct the inner case so as to place them on end, and thus give a deeper comb for the winter. Layers

of newspapers may come next outside the cloth covering of the framework. Wheat chaff answers well to complete the packing. Wool is to be preferred, but is of course too expensive unless a waste product. Ground cork, waste flax, hemp, sawdust, etc., in fact, any fine porous material, if thoroughly dry, may be used.

A board passageway three or four inches wide and three-eighths of an inch high should connect this inner apartment and the flight hole of the outer case, thus affording an exit for the bees whenever the weather may permit them to fly. When these preparations have been completed, the hive is ready for the combs, which, with adhering bees, are taken from the summer hive and inserted in the winter hive. A quilt is then laid on the frames and the top packing put on. This, for convenience, may be held in a cloth-bottomed tray. It is quite important as already mentioned, that air be allowed to circulate freely above the packing. The outside case must be quite rainproof or else wholly protected from the rain by a roof.

All other necessary conditions having been complied with shortly after the gathering season closed, the combs may be lifted from the summer hives and placed in these specially arranged winter cases before cold weather wholly stops the bees from flying out. Thus prepared for the winter the colonies will need but slight attention from October until March, or, in the North, even later, and the losses will be limited to the small percentage of cases due to failure of apparently good queens.

The Risk of Loss Through Disease and Enemies

Winter losses through disease superinduced by unfavorable surroundings which it is within the power of the bee keeper to avoid have already been considered. But one other very serious disease has been widespread.

Foul Brood or Bacillus of the Hive

This is a highly contagious affection which, as it mainly affects the developing brood in the cells, is commonly known as "foul brood." It is due to a microbe

(*Bacillus alvei*) whose spores are easily transported from hive to hive by the bees themselves, by the operator, in honey, or in combs changed from one hive to another. Once established in an apiary, it usually spreads, unless speedily and energetically checked, until all of the colonies in the neighborhood are ruined and even exterminated. The most apparent symptoms are the turning black of larvae in open cells, many sealed cells with sunken caps, frequently broken in and containing dead larvae or pupae in a putrid condition, brown or coffee-colored, jelly-like or ropy in consistency, and giving off an offensive odor. The disease, though known to exist in nearly all countries, can hardly be said to be common. The writer, in an experience of over 30 years in bee keeping in several states of the Union, as well as in a number of foreign countries, has met the disease but rarely, and has had but one experience with it in his own apiary, it having been in this instance brought in by a neighbor who purchased bees at a distance. It was easily cured, without great loss. Thus the beginner's risks of disaster in this direction are, if he be forewarned, comparatively small. He may, furthermore, gain assurance from the fact that, should the disease invade his apiary, prompt and intelligent action will prevent serious loss.

The following is the treatment for a colony which still has sufficient strength of numbers to be worth saving: The bees are to be shaken from their combs just at nightfall into an empty box, which is to be removed at once to a cool, dark place. They are to be confined to the box, but it must be well ventilated through openings covered with wire cloth. During the first 48 hours no food should be given to them, and during the second 48 hours only a small amount of medicated syrup—a half pint daily for a small colony to a pint for a strong one. This food is prepared by adding one part of pure carbolic acid or phenol to 600 or 700 parts of sugar syrup or honey. At the end of the fourth day the bees are to be shaken into a clean hive supplied with starters of comb foundation. This hive is to be placed outside on a stand some dis-

tance from all other colonies, and moderate feeding with medicated syrup or honey should be continued for a few days thereafter.

The combs of diseased colonies which contain brood may be assembled over a single one of these colonies, or, if the amount of brood be too great for one colony to care for, over several such diseased colonies, until the young bees have emerged. All of the honey is then to be extracted. While it is wholesome as food, it should not be offered for sale, lest some of it be used in feeding bees or be inadvertently exposed where foraging bees might find it and carry to their hives the germs of this disease, harmless to other creatures but so fatal to bee life. A good use for this honey is to employ it in making vinegar.

If the honey containing the germs is to be used for feeding bees, it is to be diluted with half its own quantity, by measure, of water and kept at the boiling point for three hours in a water bath—a vessel within another containing water.

The combs from which the honey has been extracted, as well as all of the pieces built by the bees during their four days' confinement, may be melted into wax, by thorough boiling in soft water. This wax should be kept liquid for 48 hours or longer, to allow all impurities to settle. These will include the foul brood spores, which may then be removed with the impure wax by scraping or cutting away the bottom of the cake. These scrapings should be burned. The same disposition had better be made of the frames from which the combs containing germs were removed.

In all of this work the utmost care should be exercised to avoid the dripping of honey about the apiary or the exposure of implements, receptacles, or combs smeared with or containing honey from the diseased colonies. The old hive and all utensils used about the diseased colony should be disinfected by washing in a solution of corrosive sublimate. If it be found that the diseased colonies are weak in numbers and seem, therefore, individually hardly worth saving, several

colonies may be smoked and shaken together into the same box to make a single strong colony, the best queen of the lot having been selected and caged in the box in such a way that the workers can release her within a few hours by eating through candy.

Bee Paralysis

Among other diseases of a bacterial nature paralysis is most noticeable, although not to be dreaded as foul brood. It affects the adult bees only, producing a paralyzed condition of their members and a swelling up of their bodies. The source from which the bees obtain the original infection is unknown, but, once in the apiary, it is spread mainly by the entrance of affected workers into healthy colonies, and probably also by the visits which bees from healthy colonies make to the diseased ones, the latter often being so weakened in numbers as to be unable to protect their stores from healthy bees out on robbing expeditions.

Ordinary paralysis may generally be cured by strewing powdered sulphur over the combs, bees, and along the top bars of the frames, the precaution first having been taken of removing all unsealed brood. This brood would be killed by the application of sulphur, but as there is no danger whatever of spreading the disease by the transfer of brood or honey from one hive to another, provided absolutely every one of the adult bees has first been shaken or brushed from the combs, the latter may be given to healthy colonies which need strengthening.

Another simple plan for getting rid of the disease and yet utilizing the available strength of the affected colonies is to close their hives at night and move them a mile or more, locating them, if possible, outside of the range of other bees. As the brood in these colonies remains healthy all that is sealed or even well advanced in the larval stage may have the bees shaken from it and be distributed among the remaining colonies of the apiary. The bees of the diseased colonies thus become rapidly reduced in numbers, and several of the colonies themselves may soon be combined, the best

queen being selected to continue egg laying. Eventually the diseased apiary becomes, by the removal of the developing brood and the death of the old bees, reduced to nothing. None of the queens should be saved nor should any of the adult workers be returned to the healthy apiary.

A combination of the sulphur cure with the last plan mentioned—that of getting rid of the disease through the removal of brood combs from affected colonies—is really, all in all, the best procedure. When a fairly strong colony has been made up by shaking the adult bees of two or more together and this removed to an isolated locality, the application of sulphur may be made before any brood has been started. It is well, also, to replace the queen with a vigorous one from stock entirely unrelated to the diseased bees. Should any signs of the disease reappear, constant removal of the brood should be followed, as mentioned in the preceding paragraph.

Other bacterial diseases, though existing, have developed only very locally or have been too limited in the amount of injury inflicted to require special mention here.

Insect and Other Enemies

The bee or wax moth (*Galleria mellonella* Linn.) is regarded by those unfamiliar with modern methods in bee keeping as a very serious enemy to success in this work. It was frequently such when only the common black bee was kept and the old way of managing, or rather of trusting to luck, was followed. But with the better races now introduced and with improved hives and methods, and especially with the care that is now given to have no colonies queenless long at a time, the wax-moth larvae are no longer regarded with great concern.

Spiders, toads, and lizards destroy, in addition to many injurious insects, also some bees, and should be tolerated in the vegetable garden rather than in the apiary.

Swallows, kingbirds or bee martins, mice, skunks, and bears only occasionally commit depredations in the apiary.

Properly constructed hives enable the bees to limit in a great measure the injury which these various enemies might inflict, and the avoidance of overswarming, with care to insure the constant presence of a prolific queen and a supply of food suited to the needs of the colony at the time, will keep it populous and therefore in shape to repel attacks or to make good most of the unavoidable losses.

Robber Bees

Robbing is sometimes a more serious matter, although a little careful attention just at the right time on the part of the bee keeper would avoid all serious trouble on this score. When bees find nothing to gather during weather when they can still fly out they are easily tempted to appropriate the stores of weaker colonies. Exposure of combs of honey at such times may even occasion a combined attack upon a good colony otherwise quite able to take care of itself. It is then that the greatest destruction ensues, for such a colony will defend itself vigorously, and a pitched battle, with perhaps 50,000 or 60,000 Amazons on either side, leaves the ground literally strewn with dead and dying.

If the invaders conquer, every drop of honey is taken from the few vanquished that are likely to be still alive; and in turn the despoilers invariably fight among themselves as to the possession of the booty. When the robbing takes place during the absence of the owner, the condition of the robbed colony may not attract immediate attention, and during warm weather moth larvae gain full possession of the combs within a few days. When this condition is observed, the whole damage is very likely to be attributed to the moth larvae. Colonies that have been left queenless for some time, and those weakened by disease or by overswarming, are especial marks for such attacks. Of course these defects should be remedied whenever observed, but meanwhile, if legitimate field work is likely to be interrupted, every colony should be assisted in protecting itself

against assault by having its hive made secure and the entrance such a narrow pass as to enable a few workers to repel attack there.

Should robbers get well started before being observed, the entrance of the hive should be narrowed at once, and wet grass or weeds may be thrown loosely over it, or a pane of glass may be stood against the front of the hive in a slanting manner to confuse the intruders. In extreme cases the attacked colonies may be removed to a cellar for a few days, plenty of ventilation being given during confinement, and a new location, apart from other colonies, selected, on which they are to be placed just at nightfall; or, instead of putting them in the cellar, they may be taken a mile or more away and returned only when the danger has passed. With these precautions, little loss is to be feared on this score.

In general, the intelligent owner who gives careful attention to certain important points in bee management finds that he very rarely has disease to contend with, and that the reduction of profits through the depredations of bee enemies is not, in most parts of the Union, a serious discouragement. Altogether it seems to the writer that the risks in these directions are even less in bee keeping than those usually met in the keeping of other animals, which, like bees, are legitimately made to contribute to the wealth of the individual and of the nation.

Journals Treating of Apiculture

As a matter of general information, the following list of journals relating to apiculture is given. It comprises all those published in this country at the present time.

The American Bee Journal, Chicago, Ill.

Gleanings in Bee Culture, Medina, Ohio.

The Bee Keepers' Review, Flint, Mich.

The American Bee Keeper, Falconer, N. Y.

The Progressive Bee Keeper, Higginsville, Mo.

Western Bee Journal, Kingsburg, Cal.

The Rural Bee Keeper, River Falls, Wis.

Beets

The beet is used as a garden vegetable, for feeding stock, and making sugar. There are about 40 varieties of the beet in cultivation in the United States ranging in color from deep red to white.

The Sugar Beet

The cultivation of the sugar beet in the United States, for the manufacture of sugar, is one of the important industries. The variety grown for this purpose, is generally the *Beta maritima*. In the earlier manufacture of beet sugar in Europe, the beet only yielded about 4.5 per cent sugar for the red variety, and 6.2 per cent for the white. At the present time, the varieties have been so improved by the selection of seed, by manuring and the careful selection of soil, that they now yield from 10 per cent, to 13 per cent sugar. In some parts of the country, the average weight of beets per acre, has been as high as 26 tons, and the average percentage of sugar in the juice, as high as 16 per cent. After the sugar is extracted, it is common to use the pulp as food for stock.

Garden Beets

Among the varieties of garden beets are the following:

Eclipse.—A very early, dark-red, turnip shaped variety, of good quality, a favorite with market gardeners, may be planted early in spring, and at almost any time during the later season.

Early Turnip Beet, Baastions.—A valuable early variety, sweet, tender, and one of the best for early and late planting.

Egyptian.—A good variety for early spring sowing.

Dewing's Improved Blood Turnip Beet.—A first class beet, for winter or summer use.

Stock Beets

These varieties are very prolific, yield heavily per acre, and require a rich deep soil.

Planting

The seed may be sown in hot beds for early planting, or it may be sown in the open ground and the plants removed to

the field or garden; or it may be sown in the rows where the beets are to grow. In this case it should be sown in sufficient quantities, so that the plants may be thinned to the proper distance apart. In the garden, the seeds are generally sown in drills, about 15 inches apart, and the plants thinned to about 8 inches. The stock beets and sugar beets, growing to much larger size, must be planted farther apart. The ground should be rich and loose, because the beet is a heavy feeder, and requires a fertile soil. In the arid regions where irrigation is practiced, where the alkali leaches from the soil and is deposited on the low lands, it has been demonstrated that sugar beets and stock beets will stand a much larger content of alkali, than most other crops; therefore lands that have been abandoned for general farming, because they were too strong in alkali to grow crops successfully, have proven to be valuable for the growing of sugar beets.

Varieties

Eclipse, Edmund Blood Turnip, Crosby's Egyptian, Blood Red, Dreer Excelsior.

GRANVILLE LOWTHER

Sugar Beet Growing Under Irrigation

C. O. TOWNSEND

*Pathologist, Cotton and Truck Disease
and Sugar Plant Investigations*

Introduction

The present sugar beet belt of the United States, that is, the area within which the soil and climatic conditions admit of the successful production of sugar beets for the manufacture of sugar, extends entirely across the northern portion of this country. The present southern boundary of this area is a somewhat indefinite and irregular line that may be said to extend from Virginia on the east to the southern part of California on the west. Efforts are being made to extend this line farther south, thereby increasing the productive sugar beet area. This can undoubtedly be accomplished with an increased knowledge of the requirement of the sugar beet plant combined with its wide range of adapt-

ability. As it is at present this belt is capable of maintaining hundreds of sugar beet mills, the output of which would supply this country with the millions of pounds of sugar required for home consumption. A study of the great variety of soil and climatic conditions under which sugar beets thrive illustrates and emphasizes the wonderful adaptability of this remarkable plant to the wide range of conditions under which it may profitably be produced.

This article will be confined to a consideration of the conditions and cultural methods employed in those areas where there is an insufficient precipitation for the profitable production of sugar beets, namely, the central, western and southwestern portions of the United States.

Selection of Soil

In the irrigated portion of the sugar beet belt there is a great variety of soils, varying from the distinctly sandy type through the sandy and clay loams, the silt, and volcanic ash to the heavy black adobe. In the selection of soil for sugar beet culture it is safe to say that any of the soil types that are capable of producing good crops of other kinds will produce satisfactory beets.

The principal factors to be considered are the physical condition of the soil, the way in which it has been previously handled, and the climatic conditions. Much more depends upon these factors than upon the kind or type of soil to be used. The physical condition of the soil depends to a considerable extent upon the previous crops and the way in which the soil has been handled. The soil should be well supplied with humus, not only to insure its fertility but to improve its water-holding capacity. The previous cropping should have been such that the ground is in good tilth and reasonably free from pests that are capable of injuring sugar beets. The soil should be well drained, either naturally or artificially, in order to prevent water-logging, and the ground should be kept sweet and at the same time free from an excess of alkali. Most of the western soils are well supplied with lime, but an

occasional application will in some cases be found beneficial.

Extremely sandy soils should not be selected for sugar beet growing, especially in localities where high winds prevail in the spring. The adobe and silty soils should be handled with considerable care to prevent baking and crusting. It is generally assumed that new sod ground is not suitable for beets, but experience has shown that good results may be obtained from our western virgin soils. If such ground is to be planted to beets the sod should be broken in the summer, the ground fall plowed, worked down, and kept moist so that the sod will rot.

The kind and location of the subsoil are always important factors. In some cases the subsoil is very porous. This condition can be relieved to some extent by increasing the humus supply in the soil and by giving special attention to firming the seed and root beds in order that their water-holding capacity may be increased. If the subsoil is extremely porous and deep, it would not be advisable to use the soil for beet culture.

If the hardpan is close to the surface, so that there is not sufficient depth of soil to produce sugar beets, the field should not be used. If a good soil to the depth of 18 inches or more covers the hardpan, it will be safe.

Climatic Conditions

The principal climatic factors which have a direct bearing upon sugar beet culture are temperature, precipitation, and winds. A study of the most successful sugar beet localities of the world leads to the conclusion that beets of the best quality can not be grown where the average temperature for the season when the beets are being grown is much above 70 degrees Fahrenheit.

Low temperatures are most likely to be injurious to sugar beets when the plantlets are just breaking through the ground, but after the roots are established in the soil they rapidly become hardy and resistant to frost to a marked degree. A killing frost when the beets are coming up often necessitates the expense and labor of replanting.

The great danger from low temperatures at the end of the growing season is that the beets may be frozen in the ground. To avoid this danger and the consequent loss that might result from such a condition it is advisable to get the beets out of the ground as soon as possible after they are ripe and to cover them to avoid freezing or drying. Apparently beet roots are not injured for sugar-making purposes by freezing, provided that they freeze and remain frozen until they are put through the mill, but alternate freezing and thawing causes them to decay and blacken, so that their value for sugar making is materially decreased.

The practice that prevails in some localities of letting the natural moisture escape from the soil, with the idea that more water can be applied when it is needed, is most pernicious and should not be followed. The moisture that falls upon the ground in the form of precipitation and is received and retained by the soil acts upon the plant foods day after day and week after week and accomplishes most for plant growth. There is a feeling of safety in having an unlimited supply of water for irrigation purposes, but it should be remembered that irrigation costs money and labor; precipitation is nature's gift.

Winds have been briefly mentioned in connection with soil selection for sugar beets, but they have a still wider bearing upon crop conditions.

The blowing of the soil and the excessive evaporation may often be reduced to the point of successful crop production by keeping the surface of the ground covered with a lump mulch. The mulch retards the evaporation, while its lumpy condition reduces the shifting of the soil. The cutting action of the shifting sand may be controlled by planting the beet rows at right angles to the direction of the prevailing winds when practicable and by attaching irrigating shovels to the drills, so that the ridges capable of protecting the young plants will be thrown up between the rows at planting time.

Plowing

The time, the depth, and the kind of plowing done and the condition of the ground at the time of plowing are all important factors in preparing the soil for sugar beets. As a rule, the most satisfactory time to plow for beets is in the fall, for the reason that fall-plowed ground is in better condition to receive the winter moisture and consequently to respond to the freezing and thawing action which tends to put the soil in the best physical and chemical condition for plant production.

In the irrigated sections plowing should never be left until spring if it can possibly be done earlier. In the first place the rush of spring work is not favorable to the best kind of plowing, but more important is the fact that stirring the ground to such a depth so close to planting time promotes evaporation and often the entire seed and root beds are comparatively dry before the seed is planted.

If done in the fall, there is very little danger of plowing too deep. Other things being equal, plowing to a depth of 10 to 14 inches or more will give the best results. Subsoil plowing is not generally practiced, and in cases where deep plowing is done and the soil below the plowed area is not too hard for the beet roots to penetrate it readily subsoiling would not pay for the labor and money expended. Where for any reason the plowing can not be done to the desired depth and the underlying soil is hard, it will pay to run the subsoil plow.

Ground is in proper condition for plowing when it is neither too wet nor too dry. Under no circumstances should ground be plowed when wet, since plowing under such circumstances injures the physical condition of the soil to an extent that often requires years to correct. Plowing should always be done when the ground is in what is called a friable condition, that is, when it is capable of falling apart as the furrow is turned so that there are no air spaces below, as is the case when the ground is too wet or when it is dry and cloddy.

The Seed and Root Beds

The seed requires a uniformly fine, firm, moist bed in order to produce a quick and uniform germination, which is especially desirable in beet culture. The more quickly the seeds germinate, the more certain is a good stand, which is the first requirement of a satisfactory crop. The plants require a fine, firm, moist, well-aerated root bed in order to make a satisfactory growth. The root bed must be fine and firm because the plants must be held firmly in place during their entire period of growth, and the soil particles must be closely in contact with the feeding rootlets. The soil must be moist enough to supply the plants with mineral food in solution and with enough water to promote constant and rapid growth.

At the same time there must not be in the soil for any considerable period of time so much water that a free interchange of soil gases can not take place.

If the ground is properly plowed in the fall when its physical condition is right, the root bed will be fine and free from air spaces. The winter moisture will usually pack the fall-plowed ground, so that the root bed will be firm. In the absence of natural winter rain or snow, winter irrigation should be practiced; otherwise, two of the most important objects of fall plowing will be lost, namely, the firming of the seed and root beds and the changes in the soil due to freezing and thawing.

If the ground is not plowed until spring, the seed and root beds must be artificially packed. This can best be done with a sub-surface packer, which should follow immediately behind the plow. The packer should be followed immediately by the harrow, in order to form the necessary mulch and to retain the moisture in the soil. This mulch should be maintained until planting time, when, if the seed bed is not sufficiently firm, the roller and harrow should be used until the proper degree of firmness is produced. Due regard should be given to the condition of the soil when these implements are used, so that the flocculent condition of the soil is not destroyed. The ground should be so firm before the seed is put into it that

even the horses' feet make but little impression upon it.

Another important point in preparing the ground for beets is to see that it is properly leveled. A properly leveled field can be irrigated much more quickly, and, furthermore, if not properly leveled there will be high spots where the beets suffer from lack of sufficient moisture and low spots where the plants are injured by too heavy watering.

Drainage

At first thought, drainage in an irrigated section of the country might seem unnecessary, but experience has shown that under certain conditions the constant applications of water cause the soil to become water-logged.

There are two general systems of artificial drainage that may be used for carrying off the excess of water or for removing the excess of salts from the soil, namely, (1) the open ditch and (2) the blind ditch in which tile or a similar conducting channel is used to aid the flow of the water through the ground. The blind ditch is most often used, and while its initial cost is somewhat greater than that of the open ditch it is more economical in the end, since it still allows the use of the land and if properly constructed does not require the expenditure of time and labor necessitated by the open ditch to keep it in working order.

Irrigation

The proper use of irrigating water is one of the most important factors in the growing of sugar beets under irrigation. The time and method of application and the quantity of water used are the essential considerations in the irrigation of sugar beets. In all irrigated sections there is some precipitation in the form of rain or snow, although this precipitation is uncertain both as to time and amount. However, it should always be conserved and utilized to the fullest extent and the irrigating water should be looked upon as an insurance to carry the crop over periods of drought. It is usual in some localities to irrigate beets up; that is, the seed is planted in dry ground and the field is then flooded in order to germinate the

seed. This is a poor practice and should be avoided whenever possible, especially in fields in which the soil has a tendency to form a crust. It is much more satisfactory to irrigate before planting if enough natural moisture can not be retained in the soil to produce germination.

In irrigating before germination it is generally best to corrugate the land, making the corrugations 5 or 6 inches deep and about 20 inches apart. The water should then be run into the corrugations until the ground is thoroughly wet. As soon as the surface of the ground is sufficiently dry to work it should be harrowed down and planted. Whether the germination is produced by the moisture already in the soil or whether it is produced by irrigation, the plants should be carried just as long as possible after they are up before they are watered. The object in withholding the water as long as possible is to produce long roots, since long roots are essential for a good tonnage.

In watering beets after they are up they should never be flooded, but should be watered in furrows between the rows. This is especially important while the beets are small, since flooding at that time is likely to scald the beet stems and to produce a crust on the surface of the ground. Usually suitable furrows between the beet rows can be made by means of irrigating shovels, which may be attached to the cultivator. If the furrows made in this manner are not deep enough and smooth enough to carry the water readily, which will depend upon the slope of the land and the nature of the soil, they should be logged out. This can be done by running the corrugators behind the cultivator. The same implement can be used to prepare the ground for watering before planting and after the beets are up.

After the furrows are properly prepared, the water should be allowed to run slowly through them, so that they will not overflow and so that the ground will be thoroughly wet down and the water seep out to the beets. After each watering the

ground should be cultivated just as soon as the surface is dry enough to work. The mulch produced by the cultivator should be maintained by frequent cultivation in order to hold the water as long as possible.

The quantity of water that should be applied in order to produce a crop of beets can not be stated in specific terms, since the water absorbing and retaining ability of different soils varies and the rate of evaporation varies both in different localities and in the same locality under the constantly changing atmospheric conditions. The plants themselves should be the index as to the quantity of water required. So long as the beets have a fresh appearance and a bright-green color they are not suffering for lack of water, and if furrow irrigation is practiced there is little danger of giving them too much water. A dark-green color of the beet leaves usually indicates that the water supply in the soil is running low. This is often followed by a wilting of the beets and a consequent retardation in growth. If the wilted beets fail to revive during the night, practically no growth can take place and water should be applied immediately.

Holding the Moisture

By nature soils vary within wide limits as to their water-holding capacity. For example, a fine, compact soil is capable of holding more moisture than a coarse or loose soil.

Humus affords a good medium in which the soil organisms can live and thrive and liberate plant food, but they can perform their functions to a much higher degree because of the additional moisture which the soil is able to retain on account of the presence of the humus. If, then, the soil has been supplied with the requisite amount of humus and has been plowed uniformly deep at the right time, much has been done toward furnishing the plants with the moisture needed for plant growth. Special attention should then be paid to keeping the surface of the soil constantly in the form of a mulch. This mulch acts as a blanket in retarding evaporation from the soil

below. Everyone is familiar with the moist appearance of the ground under a layer of straw, manure, or other loose covering as compared with the exposed surface of the adjacent ground.

Planting the Seed

If the seed bed has been thoroughly prepared, the principal factors to be considered in connection with planting the seed are the time and depth of planting, the quantity of seed used, and the distance between rows. The seed should not be put into the ground until the soil is warm enough to produce a quick germination and a rapid subsequent growth. If the seed lies in the ground when the conditions are not right for germination it is liable to rot, and even if it does not rot, the resulting plants, when they do finally develop, will usually be weak and unsatisfactory.

The desire to give the plants every advantage of a long season often leads to the mistake of planting too early. Experience has shown that almost invariably the plantings that are made later, when the temperature conditions for germination and growth are right, give the best results in tonnage and quality, and the beets usually mature in advance of the earlier plantings. On the other hand, the planting should not be delayed until the moisture has escaped from the seed bed.

The seed should be planted just as shallow as is consistent with quick and uniform germination. The depth of planting will vary, therefore, with the nature of the soil and the condition of climate. The seed should always be put into moist soil and the soil should be capable of holding its moisture long enough to produce germination. It is questionable whether it is ever wise to plant more than 1½ inches deep, for the reason that the beet seed proper is comparatively small and the young plant must be able to get through to the light by using the reserve plant food in the seed.

As an aid in holding the moisture in the soil, the drill should be provided with press wheels, which exert a firm, even pressure upon the soil directly over the drill row. Furthermore, a firm soil acts

like a lamp wick and draws the moisture up from below.

Plant all the seed at a uniform depth. The importance of this will be apparent when we consider the operation of thinning the beets. Only two conditions are necessary in order to plant at a uniform depth. First, the surface of the ground must be smooth and firm, and, second, the drill shoes must each stand on the same level.

In order to get a good stand of beets, which is the first requisite of a satisfactory crop, plenty of seed must be used, so there will be no gaps or spaces of any considerable distance where there are no beets. Usually from 15 to 20 pounds of seed per acre will be sufficient to accomplish this result. If a large number of seeds germinate at the same time, each plantlet will help others to get through to the light; hence the importance of plenty of seed in a well-prepared seed bed.

Experience has determined that in general the most satisfactory distance between rows is from 18 to 22 inches. It is evident that very fertile soil capable of holding an abundance of moisture will yield better results with narrow rows than will a less fertile soil with a lower water-holding capacity.

Spacing and Thinning

As already indicated, the present method of planting beet seed is in solid rows instead of in hills, in order to obtain a more uniform and nearly perfect stand of beets. Having secured a good germination it next becomes important to thin the beets down to one in a place at suitable distances apart in the row to produce a good crop. The first step in reducing the beets to one in a place is that of spacing the beets, which is usually done with a hand hoe used at right angles to the row. In this manner a large number of the plants are cut out and the remaining beets are left in small tufts at intervals of 8 to 12 inches in the row. In performing this operation the hoe should be struck just deep enough so that the beets cut off will not grow again and so that all weeds that may have started in the row will be destroyed.

Several machines have been devised for spacing beets, but they have not come into general use.

As soon as the beets have been spaced, the tufts should be thinned to one in a place. This work must be done with the hands, since the beet plants stand so close together that no machine has been devised that is capable of doing the work satisfactorily. It is seldom the case that two beets left in the same tuft will produce the same weight of beet roots that would have been produced by either of the beets alone.

The beets should be spaced and thinned just as soon as possible after they are up. This can usually be done when the plants have from 4 to 6 leaves.

Cultivating

There are three principal objects to be accomplished by the use of the cultivator; namely, the destruction of weeds, the retention of moisture, and the interchange of gases in the soil. The purpose for which the cultivator is operated should be kept in mind, and the cultivator should be fitted with attachments accordingly. In using the weeder care should be taken that they do not form a crust just below the mulch produced by the weeder blades. This may be avoided by attaching calf-tongues just back of the weeder and so setting them that the points operate a little deeper than the weeder blades.

Some growers are partial to the disks when the beets are small. These are useful if the main object is the formation of a mulch or if a light crust has formed which it is desired to break and at the same time to form a mulch. The disks, if properly set, prevent the dirt from being thrown over the young beets, which is a point that should be strongly emphasized at every cultivation, regardless of the kind of attachments used. The objection to the disk is that it leaves a furrow on either side of the beet row, and consequently the plants stand on a ridge, which is inclined to dry out. To avoid this condition a bull-tongue should be attached back of each of the disks and so adjusted that the furrows formed by

the disks are filled in with the loose dirt, so that the surface of the ground is level.

While the beets are small it is safe to cultivate fairly deep and quite close to the plants. The depth to which the ground is stirred when the beets are small should never be as great as the depth to which the roots have penetrated and never need exceed from 3 to 4 inches in order to accomplish the object of the cultivation. As the beets get older it is usually advisable to set the cultivator so that it does not work so deep or so close to the beets, for the reason that the feeding roots must not be disturbed. The manner in which the beets are handled while small, especially with reference to the soil moisture, will govern to a great extent the position of the feeding roots. If the ground is kept rather moist near the surface the feeding roots will develop near the surface and great injury may be done by the later cultivation. This emphasizes the importance of withholding the water from the young beets as long as possible, so that the main root will be long and the feeding roots formed well down on the main root. If this is done a deeper mulch and one that extends closer to the beets can be maintained without injury to the plants. This will be very helpful in retaining the moisture in the root bed and also in maintaining a free circulation of gases in the soil.

Before cultivating it is always advisable to examine the plants with reference to the length of the taproots and the location and length of the feeding ones.

Hoeing

Beets receive their first and in many cases their only real hoeing at the time they are thinned. At this time the ground is or should be thoroughly stirred around each beet. The hoeing should be deep enough to destroy all weeds in the beet rows and to form a continuous mulch around and between the beets. Unfortunately, in practically all sugar beet localities all hoeing after the beets are thinned consists simply in cutting out the weeds in the beet rows. The conse-

quence is that the ground in the beet rows is not stirred from the time the beets are thinned until they are harvested except at the points where weeds appear. This permits the formation of a crust, in many cases the entire length of the beet rows, through which an enormous amount of soil moisture escapes.

The destruction of weeds is of vital importance, since if allowed to grow they rob the soil of both moisture and plant food, but the stirring of the ground between the beets in the row should not be overlooked.

Harvesting

The proper time for harvesting the beets is usually determined by certain tests which show the sugar condition and purity of the juice in the roots. Each sugar company has its standard for these factors of quality, and until the roots measure up to this standard they are not considered sufficiently mature to be harvested profitably. Harvesting beets consists of several distinct operations; i. e., lifting, pulling, topping, piling, and hauling.

Lifting the beets consists in loosening them so that they can be easily pulled. Two forms of lifters are in general use. One is a double-pointed implement so constructed that one point passes along on either side of the beets and at a suitable distance from the surface so that the beets are slightly raised out of the ground. The other is a single-pointed implement somewhat resembling a subsoil plow. This passes along on one side of the beet row and loosens the dirt so that the beets are easily pulled and is called a side lifter. The side lifter usually has a lighter draft than the double-pointed implement. Aside from the draft, the important points are that all the beets be loosened and that as few roots as possible be broken. Both of these factors are often a matter of good driving. After the beets have been loosened they are pulled and thrown in piles or rows. The number of beet rows used in making one row of piles, usually consists of from 16 to 24 rows of beets.

After the beets have been pulled they are topped. This consists in cutting off each beet at the line of the lowest leaf scar, which is usually done by one stroke of a heavy knife. The object in topping the beets is to remove the leaves, which contain but a small amount of sugar, and to remove the crown or upper part of the beet, which contains a large percentage of the mineral matter taken up from the soil. The mineral matter prevents a given amount of sugar from crystallizing and for this reason should not be allowed to get into the juices in the mill. When the beets are topped the roots are thrown into piles, from which they are loaded on wagons by means of specially constructed forks; that is, the fork tines have knobs on the ends to prevent the tines from puncturing the roots. Before the beets are topped the ground where they are to be piled should be freed from clods and refuse material, so that nothing but clean beets will be forked to the wagons. If the beets can not be hauled immediately after topping they should be covered to prevent evaporation or freezing. If the weather is not cold enough to freeze the beets it is usually sufficient to cover the piles with the beet tops, but if there is danger of freezing a sufficient quantity of earth should be thrown over the piles to prevent the roots from becoming frosted. When the beets are delivered to the sugar mill or loading station, they are tared. The tare consists of two parts, the dirt tare and the crown tare. The dirt tare is the percentage of dirt that clings to the roots when loaded and the crown tare consists of the percentage of crown left on the roots, due to improper topping.

Crop Rotation

Every farm should have a well-defined system of crop rotation. The object of crop rotation, if properly arranged, is twofold. Each crop should leave the ground in better condition for the next crop than it was before, and each crop should prevent the propagation and development of plant pests. The fallacy that sugar beets injure the soil has not

only been exploded, but just the reverse has been found to be the fact. It is true that sugar beets take out of the soil the same elements that are removed by other crops, but in slightly different proportions. But, as has been stated, a large part of these mineral elements is in the top, which, if properly handled, will be returned to the soil in the form of manure, so that in the end but little plant food is removed from the soil by the beet crop. Furthermore, the beet crop leaves the soil in good tilth for the next crop. Experience in all sugar beet countries has demonstrated the fact that larger crops of grain can be grown after beets than after any other crop so far as known. This seems to be due to the excellent condition in which the soil is left by the beet crop and to the depth of the root bed occupied by the beet roots. It is not apparent that sugar beets add any fertilizing material to the soil, but the fibrous roots that are left in the ground when the beets are harvested improve its physical condition.

If sugar beets are to be one of the crops in the rotation system, the crop preceding the beets should be of such a nature that it can be harvested in time to plow the ground for beets in the fall. One of the crops in the system should be a legume, such as alfalfa, peas, beans, etc. These are nitrogen-storing crops, and if the soil is deficient in humus, as is the case in most of the irrigated sections, a green crop should be plowed under. Not more than two sugar beet crops should be grown in succession on the same field, chiefly for the reason that a continual cropping with sugar beets tends to promote the development of serious pests, such as leaf spot, root rot, and insects. It is true that more than two crops of beets may sometimes be grown in succession, but it is a dangerous practice and should be avoided.

Fertilizers

As a rule, the soils in the irrigated sections of the country are rich—that is, they contain in abundance the mineral elements necessary for plant growth; but in many cases these mineral elements are

not soluble Under such circumstances the soils, while rich, are not fertile If one or more of the required elements is lacking or is not present in the soil in sufficient quantity to produce a normal plant growth, it is clear that such element or elements should be added in an available form. If, however, the necessary plant foods are all present in the soil but some of them are not soluble, the problem is entirely different and consists in so treating the soil that all the elements are reduced to soluble forms. Frequently the fertility of a soil may be increased by giving it proper tillage at the right time without the addition of any material.

The vegetable fertilizers in common use are stable manure and green crops. The principal function of the vegetable fertilizer is to so improve the physical condition of the soil that the elements already in the soil are rendered soluble and therefore available for the plant. Nearly all irrigated soils are deficient in humus, and for this reason it is important to make use of the greatest possible amount of stable manure.

As a rule, the amount of stable manure produced upon most farms is insufficient to supply the required quantity of humus to irrigated soils. For this reason the stable manure should be supplemented by plowing under green crops. If the supply of nitrogen in the soil as well as the supply of humus is deficient, nitrogen-storing plants, such as alfalfa, clover, peas, beans, etc., should be used as a green fertilizer. If the humus only is deficient, such crops as rape, rye, sorghum, etc., may be used. A soil which is deficient in one or more of the mineral elements will not respond to the fullest extent to the addition of mineral fertilizer unless there is a sufficient amount of humus present to put the soil in good physical condition. Therefore, the physical condition as well as the chemical composition should be carefully considered in the effort to increase the fertility of soils.

Live Stock

One of the most important adjuncts of a farm on which sugar beets are

grown is live stock, especially dairy cows. It is doubtful whether any sugar beet territory can build up a permanent agriculture unless considerable attention is given to the production of live stock. Not only will the live stock, if properly handled, produce an important part of the farm income, but they are very essential in the matter of soil improvement, which is brought about through the proper use of the barnyard manure The keeping of live stock enables the beet grower to make the best possible use of the beet tops This feed, in connection with roughage which is easily produced, keeps the live stock in good condition and enables the farmer to return the mineral elements in the tops to the soil and at the same time to increase the supply of soil humus.

Sheep as well as cattle thrive on beet tops, but it is wise to feed them sparingly at first and to increase the allowance as the stock become more accustomed to this feed. The practice in some localities of pasturing the tops after the beet roots have been hauled from the field has the advantage that it saves the time and labor of hauling them, but it is more or less wasteful. Furthermore, the ground is often injured by the trampling of the stock, so that altogether the most satisfactory plan is to gather and haul the tops to the feed yard, where they should be fed in properly constructed racks to avoid waste.

By-Products

The by-products of the beet field and sugar mill that are of special importance to the farmer are the beet tops, the pulp, and the waste lime. Many farmers sell the tops for a cash price ranging from \$2.50 to \$5 per acre. In this case the beet grower is the loser, for two reasons. In the first place, the tops are of greater value to him as a stock food; and, in the second place, if he allows the tops to leave his farm he loses their manurial value.

The most economical way to handle the tops is to gather them into piles soon after they wilt and before they become thoroughly dried However, if any dis-

ease, especially leaf spot or crown rot, is noticeable on the beet leaves and crowns, the manure should be used only on ground that is not to be put into beets for two or more years; or, better, the freshly wilted beet tops should be put into the silo, preferably mixed with cut straw or corn stover. Leaf spot pores are all killed in the silo.

Beet pulp is likewise an excellent stock food. This by-product is the refuse that remains after the beet roots have been sliced and the sugar extracted. As a stock food it may be used either as green pulp—that is, just as it comes from the mill—or it may be dried. The composition of the dried pulp as guaranteed by one of the large dealers is as follows: Protein, not under eight per cent; fat, not under one-half of one per cent; sugar and starch, not under four per cent; fiber, not over 20 per cent; extract (carbohydrates), not under 58 per cent. Total carbohydrates, including fiber, not under 76 per cent; ashes, two and one-half per cent. While the pulp, either green or dried, is an excellent stock food it is not a balanced ration and should therefore be fed with other protein material.

Waste lime is a by-product of the sugar mill which, under certain conditions, is of considerable value to the farmer in correcting the acid condition of the soil. It is well known that a soil should be neutral or slightly alkaline in order to produce the best results. Ordinarily, an application of from 500 to 2,000 pounds of waste lime per acre will correct the acidity and otherwise improve the soil.

Summary

Sugar beet soil should be selected with reference to its fertility, its physical condition, its previous cropping, and its ability to be properly drained and irrigated.

The ground should be plowed to a good depth in the fall and every effort made to retain the moisture in the soil from the time the previous crop was harvested until the beet crop is laid by.

The seed and root beds should be so prepared that they will be fine, firm, moist, and well aerated, with a sufficiently lumpy mulch on the surface to prevent blowing.

Beet ground should never be flooded after the seed is planted.

The soil should be well supplied with humus.

Beet seed should be planted in moist soil, but not more than one and one-half inches deep.

Beets should be spaced and thinned just as soon as they are large enough to handle.

Beets should be cultivated and hoed often enough to destroy all weeds and to keep the entire surface of the ground covered with a mulch.

Beets should always be rotated with other crops in order to keep the soil in good tilth and free from pests.

Live stock, especially dairy cows, should always be found on beet farms.

The by-products of the sugar beet and of the sugar mill are worthy of careful attention.

Beet-Sugar Crop in the United States for the Year 1911-12

State	Factories		Area harvested	Yield	Value per ton	Beets worked	Sucrose	Sugar manufactured	Recovery		Loss of Beets
	No	Run							Beets	Sucrose	
	Days	Acres	Short tons	Dollars	Short tons	Per cent	Short tons	Per cent	Per cent	Per cent	
California...	10	98.5	99,545	10.42	5 54	1,037,283	18.95	161,300	15.55	82.04	3.40
Colorado...	14	63.3	86,437	11 07	5.55	957,142	15.44	124,800	13.04	81.22	2.40
Idaho....	3	91	17,052	12.11	5.02	206,367	16.65	26,730	12.95	77.80	3.70
Michigan...	17	122	145,837	9.90	5.74	1,443,856	14.59	125,500	8.69	59.55	5.90
Utah.....	6	96	33,950	13.03	4 81	442,310	15.98	57,280	12.95	81.04	3.02
Wisconsin...	4	106	23,241	11.02	5.51	256,124	14.23	23,640	9.23	64.86	5.00
Other States	12	83	67,815	10.61	5.48	719,251	15.16	80,250	11.16	73.60	4.00
Total or average...	66	94+	473,877	10.68	5.50	5,062,333	15.89	599,500	11.84	73.92	4.05

Compiled in the office of Cotton and Truck Disease and Sugar-Plant Investigations, Bureau of Plant Industry.

Sugar Beets in Europe

The following table gives the area and production of sugar beets in European countries in 1912 and 1911, according to a report of the International Institute of Agriculture:

Area and production of sugar beets in specified countries, 1912-11.

Country	Area		Production	
	1912	1911	1912	1911
	Acres	Acres	Tons(2,000 lbs.)	Tons(2,000 lbs.)
Prussia.....	1,053,454	865,559	14,289,352	6,609,550
Belgium... ..	163,086	150,237	2,094,370	1,626,995
Bulgaria... ..	7,413	7,331	49,604	68,343
Denmark... ..	74,871	61,528	885,729	805,208
Spain... ..	106,438	82,121	1,189,353	964,463
France.....	606,346	600,280	7,037,204	4,669,083
Croatia and Slavonia.....	7,413	7,413	99,207	66,138
Italy.....	130,963	131,260	1,818,795	1,587,753
Roumania... ..	35,491	33,613	352,736	289,962
Russia.....	1,860,196	1,923,758	14,523,444	14,343,901
Sweden.....			1,091,480	905,124

BEEET DISEASES**Beet Scab**

Thought to be the same organism as produces the potato scab and affects the roots in much the same way.

Rotation of crops is suggested.

See *Scab* under *Potato*.

Crown Rot

Phoma Betae

Distributed pretty generally throughout the beet growing sections.

CURLY TOP. See *Beet Leaf Hopper*, this section.

Downy Mildew

Peronospora schachtii

Causes a stunting of the inner leaves. Occurs during the rainy season.

Destroy all affected plants

Leaf Spot

Cercospora beticola Sacc.

Produces small dead spots in the leaves followed at times by dying of the leaves.

Bordeaux mixture applied at intervals of three weeks.

Root Knot

Caused by the Nematode gall worm.

See under *Potato*.

Root Rot

Rhizoctonia sp.

Appears in the young plant as a decay of the root. Causes the root to fork and become misshapen.

Crop rotation, or, where practicable, soil disinfection seem the best remedies.

Rust

Uromyces betae

Appears as a red rust on beet leaves when grown in the rainy season. Not serious.

BEEET PESTS

BEEET APHIS, BEEET ROOT APHIS, CALIFORNIA BEEET ROOT APHIS. See *Aphids*. See also *Beet Louse*, this section.

The Beet Army Worm

Laphygma exigua Hubn.

Family Noctuidae

Caradrina exigua Hubn.

General Appearance

The adult moth is mottled gray with distinct light markings on the fore wings. It is about one inch in length, with a wing expanse of one and one-half inches.

The larvae are slender, dark green in color and distinctly striped

Life History

The adult moths appear during the months of April and June and deposit eggs, the caterpillars hatching out in May and the last of June and becoming most abundant in August. There are probably three generations a year—the first and last doing the least amount of damage

Food Plants

The favorite food of the caterpillars is the sugar beet and it bids fair to become quite a serious pest to that crop. Table beets, corn, potatoes, peas, onions, sunflower, lambsquarters, pigweed, saltbush and the leaves of the apple, mallow, wild tobacco, plantain and wild grasses are also attacked.

Poison mash as for other cut worms.

E. O. Essig

Beet Leaf Hopper

Eutettix tenella Baker

The adult is a small, pale yellowish-green species. When fresh or when flying this leaf hopper appears almost white, and for this reason it has often been called the "white fly."

The eggs are white, elongate, slightly curved and tapering at one end, and are thrust into the leaf stem.

The nymphs are very active, pale creamy white or variously colored forms. The commonest form is pale creamy in color with a brown saddle on the middle of the abdomen.

The distribution seems to be general over the West.

The condition called "curly-leaf" or "blight" accompanies the attack of these insects and its severity is in proportion to their numbers.

Remedy

Spray with kerosene emulsion stock solution one to five parts water, using a drag to turn the beet leaves up.

Bureau Entomology Bulletin 66

Beet Louse

Pemphigus betae Doane

General Appearance

The adult wingless lice are about one-eighth of an inch long; somewhat round-

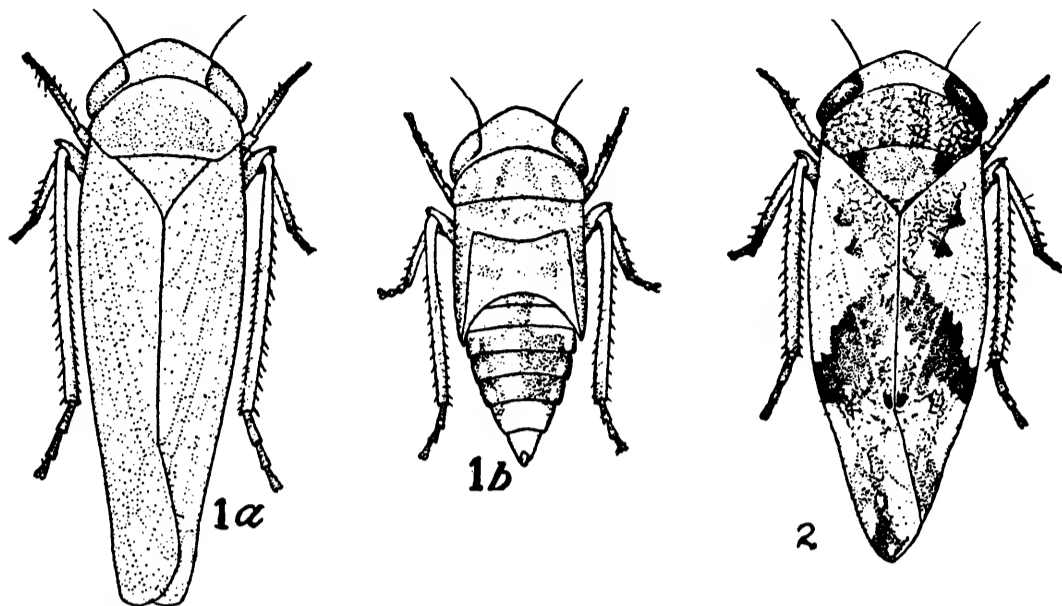

Fig. 1. Beet Leaf Hopper. 1a, Adult of *E. tenella*; 1b, Nymph; 2, Adult of *E. scitula*.

ed or elongated in shape; whitish or pale yellow in color with a large tuft of white flocculence covering the posterior end of the body. The legs, antennae, and spots on the top of the head are brown. The winged lice are a little larger, more elongated and much darker in color. The head, antennae, legs and thorax are black and being usually covered with a fine, white powder appear bluish-black; abdomen dark green. The presence of this pest is easily told by the white flocculence which covers the lice as well as surrounding infested areas on the roots.

Food Plants

As this is a subterranean aphid, only the roots are affected, but often in such a way as to ruin portions of the crop. Sugar beets are the only economic plants attacked to any injurious degree. Wild yarrow, dock, knotweed (*Polygonum aviculare*) are also attacked.

Remedy

Rotation.

E. O. ESSIG

Blister Beetles

The striped blister beetle or what is sometimes called the old-fashioned potato beetle, frequently attacks the beet. They come in immense numbers and are likely to do serious injury before their presence is observed. They are long, slender beetles with black and yellow stripes. Apply arsenate of lead as soon as the beetles appear.

FLEA BEETLES. See *Potato*.

Minute False Chinch Bug

Nysius angustatus minutus Uhl.

Family Lygaeidae

General Appearance

The adults are very small grayish-brown bugs, about one-sixteenth of an inch long. The young are somewhat lighter in color, having reddish-brown abdomens and lacking wings. The legs and antennæ appear very long and are dark.

Life History

The eggs are deposited in the spring and early summer by the adults which have hibernated during the winter. The young are dull gray or brownish-red, and collect in great numbers upon the host plants. The life cycle is short, there being many successive broods each year.

Food Plants

The insect is especially destructive to sugar beets grown for seed. It has been collected in large numbers on cultivated flowers.

Control

Soap emulsions and tobacco sprays are excellent remedies. Pyrethrum is also recommended, but is too expensive for large plantings.

E. O. ESSIG

Plant Bug

Lygus pratensis, etc.

Flattened, sucking bug, nearly one-fourth inch long when full grown, brownish in color, marked with yellow and black. Hibernates under grass and rubbish.

Sucks juices, causing plants to wither and often carries disease from sick plants to others.

Burn all rubbish in spring if this was omitted in fall. Spray young bugs with kerosene emulsion diluted with 12 to 15 parts of water. Collect old bugs by sweeping plants with cheese cloth or muslin net when insects are stupid in early morning or when it is cold.

H. A. GOSSARD,
Wooster, Ohio

SPINACH OF BEET LEAF MAGGOT. See under *Spinach*.

Western Army Worm
Chorizagrotis agrestis Grote
Family Noctuidae

General Appearance

The adult moth is about one inch long and dark brown with gray markings. The caterpillars or army worms attain a length of two inches and vary from pale green to dark brown.

Life History

The general life history is practically the same as that of the variegated cut worm (*Peridroma margaritosa* var. *saucia* Hubn.).

Food Plants

This is a rather serious vegetable pest, attacking beets, cabbage, horse-radish, radish, mustard, turnip, peas, tomatoes, potatoes, onions, celery, rhubarb, corn, grasses, clover, alfalfa and forest and fruit trees.

Poisoned bait, composed of a pound of Paris green to 40 or 50 pounds of bran and sweetened either with cheap sugar or molasses with sufficient water added to make a stiff mash, placed in the infested areas, will kill countless numbers of the worms.

E. O. ESSIG

Beneficial Insects

The California State Insectary Propagating and Distributing Beneficial Insects

The California State Insectary is a department of the state commission of horticulture, equipped and maintained for the purpose of reducing the cost of production of horticultural and agricultural

products through the control of injurious insect pests.

The primary object of this institution is to import, collect, propagate and distribute beneficial insects that will prey upon insects destructive to our fruit, vine and grain products. Information is also disseminated as to the best artificial means of control, where the natural methods are not available, both for insect pests and plant diseases.

The state of California leads the horticultural world in the science of controlling destructive insects by natural and artificial methods.

The main purpose of this article is to give the reading public a general idea of the various methods employed by the California State Insectary, in propagating, collecting, holding in cold storage and distributing the tons of live beneficial insects that are annually distributed free, upon application, express or postage paid, to resident growers of California.

This great practical work and its commercial application had its inception in California. The history of its inauguration is so well known and understood that, for the purpose of the present article, it may be passed with the brief statement that, early in the horticultural history of the state, the known means of artificial control or eradication proved inadequate to cope with the invasion of a very serious insect pest of citrus and other trees, known as the "cottony cushion scale" (*Icerya purchasi*) which reduced the citrus output from 8,000 cars to 600 in a single year.

The idea of searching the world for a beneficial insect that would prey upon and control this pest originated in California. The idea was put into practical operation by the introduction of a species of Coccinellidae (Ladybird family) from Australia, known as *Novius* (*Vedalia*) *cardinalis*, with the result that the then doomed citrus industry of California was saved and the same pest which is always present in limited numbers, was commercially and continually controlled all these years at no expense to the grower, except a two-cent stamp on the letter to the In-

sectary requesting that a colony of Australian ladybirds be sent to him to check the threatened outbreak of the pest.

Encouraged by the success of this first undertaking, the work has been successfully prosecuted for many years, until to-day California has the largest insectary in the world devoted exclusively to the introduction, propagation and dissemination of beneficial insects.

By careful study it has been determined that, in a majority of cases, what in California is termed an "insect pest" is usually a foreign destructive insect that has been accidentally introduced into the state without its natural insect check (who used it not only for food for itself, but upon which to feed and propagate its young).

The introduced species increases enormously and in a remarkably short time, by sheer force of numbers, becomes what we term "an insect pest."

From the above statement the work of the state Insectary can be easily understood. Its first duty is to locate the home of the natural insect enemy, which is usually the country from which the pest was introduced. The beneficial form is then sent to the Insectary, either through correspondence with some foreign entomologist or by sending our entomological explorer direct to that country.

After receipt at the Insectary several generations must be bred in confinement in order to segregate the secondary and even tertiary forms before any adults of the species desired may be liberated in the open.



Fig. 1. Field Agents with 300 Pounds of Ladybirds in sacks at a pack train station. Sacks are only half filled to allow the beetles to move slightly and to avoid crushing when packed on the mules. Sieves, pans, brushes and sacks used for this collecting are hanging on the fence.

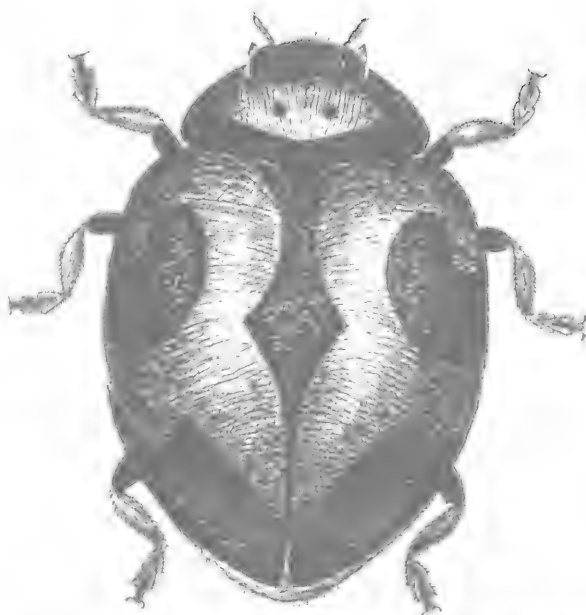

Fig. 2. The Vedalia (*Novius cardinalis* Muls.). Slightly less than one-quarter of an inch in length and oval in shape. The color pattern is very pronounced and striking, being red and black. In the females red predominates while in the males there is more black. The larvae are often over one-half of an inch long and lead-gray in color with reddish sides. They are often covered with whitish powder from the egg sacs of the cottony cushion scale. The eggs are a little larger than those of *Novius koebelei*, but are the same color and laid in similar places. The young feed upon the eggs and young scales and do great execution. The great prolificness and appetite of this species enables it to do what no other predator has yet done. It disappears with the host and is constantly being sent out by the State Insectary. Introduced in California by Albert Koebele. It feeds entirely upon the eggs and young of the cottony cushion scale (*Icerya purchasi*). To this beetle is accredited the salvation of the citrus industry in California, which was threatened with destruction by the above scale.

To this part of the work too much care cannot be given, as the success or failure of the entire undertaking hinges on the careful segregation of the species at this point.

To successfully establish an introduced species, several additional importations must be made and adults liberated as in many species if but a single introduction is made, in-breeding after a remarkably few generations will not only dwarf the species but actually stop reproduction.

Many failures to establish foreign species during the past is directly traceable to this very important feature, owing to lack of sufficient knowledge on the part of the collector who has been content with but a single introduction. This is especially true of the Coccinellidae (Ladybird) family.

We find then the main essential factors toward successful foreign introductions

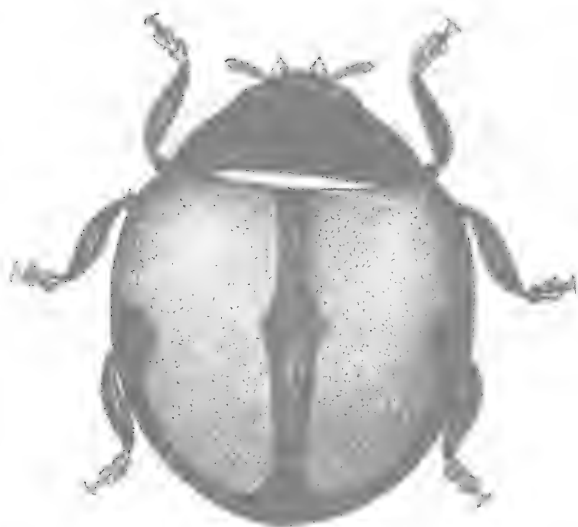

Fig. 3. Koebele's Ladybird Beetle (*Novius koeblei* Olliff). Adult male, greatly enlarged (original drawing by Birdnekoff). A very small species being not longer than one-eighth of an inch; the males are bright red with dark markings; the females red with dark head, prothorax, and marginal spot near the middle of each wing cover. The larvae are dark red and about one-fourth of an inch long. The small oblong red eggs are deposited by the females on the egg sacs of the host and hatch within a few days. The young immediately enter the egg sac and begin feeding upon the eggs and young hatched scales. It was first introduced by Albert Koebele and is continually being re-distributed by the State Insectary. It feeds upon the cottony cushion scale. (*Icerya purchasi*). This species is often more numerous and does greater execution than does the *Vedalia* (*Novius cardinalis*), for which it is usually mistaken.

are, first, the careful segregation of all secondary forms, which must be immediately destroyed and not a single individual allowed to escape. Packages must be opened in an air-tight room or tight glass case; one end covered with a black cloth curtain into which holes are cut. The package is placed inside the case, the operator puts his arms through the holes in the curtain and thus works inside the case. Second, additional importations to enable cross-breeding and to prevent in-breeding, also to give the species the advantage of different seasons in which to become established, or, in case the first shipment would meet with disaster upon being liberated.

Our foreign importations are shipped almost entirely when they are in the larval (young) or pupal (quiescent) stage and are placed in cold storage during transit.

The intricacies of cold storing insect species would require chapters to even begin to explain the various processes and, all told, it is a subject that does not lend

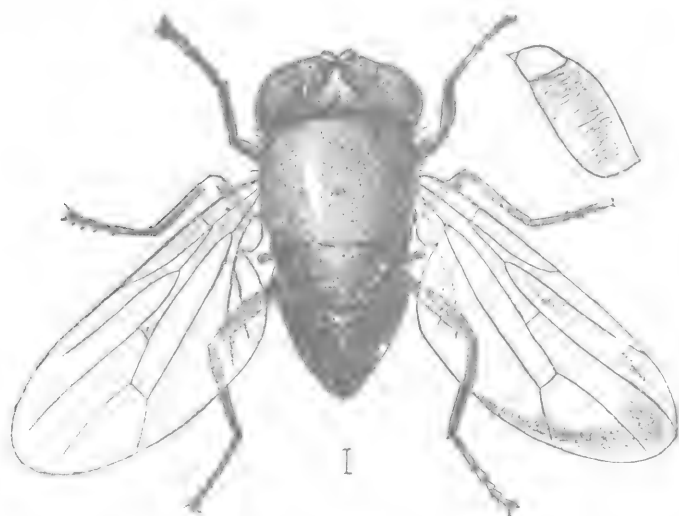

Fig. 4. Dipterous Parasite of the Cottony Cushion Scale (*Cryptochaetum iceryae* Will. [Family Agromyzidae]. *Lestophonus iceryae* Will.). The adults of this very beneficial insect are exceedingly small two-winged flies about one-sixteenth of an inch long. The head and thorax are metallic blue and the abdomen bright iridescent green. The antennae are black; legs black or dark brown with feet light; wings grayish hyaline with dark brown veins. The eggs are deposited by the females in the egg sacs of the cottony cushion scale and the young maggots feed upon the eggs of this pest. The entire life history is passed within the protecting sac of the host, the adults emerging as by magic from the masses of the scale. This fly is practically confined to the citrus-growing sections of Southern California and is more often found in Los Angeles, Orange and San Diego counties. While it is not as consistent and reliable in its work upon the cottony cushion scale as are the ladybird beetles (*Novius cardinalis* and *N. Koebele*) yet its work is often phenomenal. Certainly its rearing and distribution is well worth while.



Fig. 5. Black Ladybird Beetle (*Rhizobius ventralis* Er.). The adults are smaller than those of the common red ladybird; rather oval in shape; black and covered with fine hairs which give them a grayish appearance. The abdomen is salmon colored. The young are dark brown or black and covered with many spines. The eggs are deposited singly or a few at a place among the egg masses of mealy bugs, under the bodies of the black scale or among other scale insects. The numbers of the host are so great that the actual good done is not so marked as in the cases of many other predators. The adults move little except when annoyed. This species was imported by Albert Koebele, especially as an enemy of black scale (*Saissetia oleae*). The young feed upon the eggs of the black scale, mealy bugs, hemispherical scale and other similar insects.

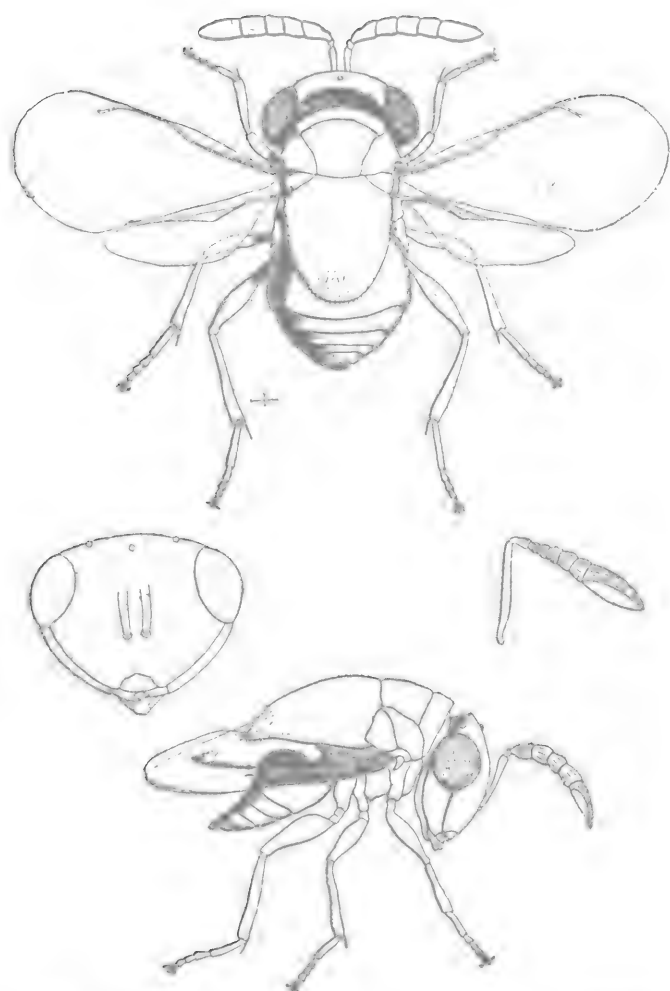

Fig. 6. The Scutellista (*Scutellista cyanea* Motsch. [Family Encyrtidae]). The adult is a small four-winged parasite, less than one-eighth of an inch long, robust and metallic steel-blue to nearly black in color. The small oblong white eggs are placed under the shell of the black scale. They are somewhat larger than the eggs of the scale and hatch in from five to six days into crescent-shaped white legless larvae, which feed upon the eggs of the black scale for 15 to 20 days, when they pupate and after another like period emerge as adults from the shells of the scale through circular holes cut for this purpose. The adult lives a little over a week. It does very effective work on the black scale in certain sections. It also works on the hemispherical scale.

itself readily to explanation but is a case of knowing "when to" and "when not to," as each species requires different care, treatment and temperature.

At the Insectary we propagate on various host plants, the destructive forms upon which we feed the beneficial forms that later on are distributed to the orchards.

The several pictures accompanying this article will give the reader an idea of the manner in which this work is carried on.

Still another very interesting phase of the work is the conservation and distribution of native species of beneficial insects.

Many native species propagate or hyber-

nate in immense quantities in certain sections of the state, which are collected when available, held in a state of artificial hibernation by the aid of cold storage, later to be judiciously distributed into new sections, where they will thrive and perform wonderful service in destroying destructive forms which are present.

The most prominent among these which we will use to illustrate this work is a native species of Coccinellidae (Ladybird) known scientifically as *Hippodamia convergens*. This phase of the work has been set forth by the writer in Vol. III of The Monthly Bulletin, published by the state commission of horticulture, of which the writer is assistant editor, and from which the following is a portion:

Throughout California the fact is quite well known that the State Insectary distributes, each year, several tons of coccinellids of the species *Hippodamia convergens*, commonly known as ladybirds, to growers of cantaloupes,, prunes, apples, pears, vegetables, seeds and garden truck, for the destruction of aphid species.

Our growers know that it is only necessary to make application to the superintendent of the Insectary, for colonies of these beneficial insects, stating the nature and acreage of the crop grown, to receive, at the proper time, a consignment of 30,000 for each ten acres, by express, charges paid, and with a free return on the shipping crates.

This new and very remarkable form of enterprise has proven a great practical success, the ladybirds being used to destroy aphids or plant lice that attack the



Fig. 7. Wells Fargo Express taking a load of Ladybirds from the Insectary for delivery to the fruit growers over the state. Several loads a day are taken during the shipping season. Six colonies are put in one crate.

above-mentioned crops. This line of work had its origin at the California State Insectary, together with the process of hibernating this and various other species in enormous quantities in artificial cold storage.

Experiments have been conducted along this line at the Insectary, whereby the *Hippodamia convergens* has been successfully kept in hibernation in cold storage, without impairing the vitality of the species for seven months and 14 days.

This particular line of work was inaugurated through practical necessity, owing to the fact that the chief obstacle to the raising of cantaloupes in California, especially in Imperial valley, has been the attack of the melon aphid (*Aphis gossypii*), often ruining whole fields in three or four days, and no mechanical or other means of fighting them had been found effective; indeed, it was only possible to get rid of them by destroying the infested vines.

The use of ladybirds for the destruction of aphids has gradually spread from their



Fig. 8. One Hundred and Thirty Pounds of Ladybirds on Pack Mule. Nine miles through the snow to the packing house.

originally appointed work, until now the Insectary ships crates upon crates to practically every county in the state of California, and to growers of almost every horticultural product subject to the attack of aphid species, even including city (ornamental) street trees and home gardens.

The particular coccinellids (*Hippodamia convergens*) used in fighting aphid infestations are a species native to California. They are of a predatory habit, and their special prey and chosen food are the aphids, upon which they feed both in the larval and adult stages.

The best results are obtained by placing colonies in the infested fields or orchards at, or just before, the first appearance of the aphids; the object being to prevent the increase of these destructive insects.

Again, the female coccinellid, if the natural food is scarce in an orchard or field, is thus forced to search diligently

for aphids, and will distribute her eggs in proportion to the number of aphids present; whereas, if the colonies were not placed until after the aphids had become abundant, she would deposit practically all her eggs in the same place. The same rule will apply to practically all cultivated crops, and therefore it is important that applicants for colonies of this particular species should place their order early, and again notify the Insectary when the very first aphids are noticed, and ask that their colony be sent them immediately.

It has been thoroughly demonstrated that by following such a procedure, with the help of the ladybirds, orchards and fields have been kept commercially clear of this obnoxious insect. So great is the demand for ladybirds by growers of melons and all other kinds of fruit, that the Insectary has been obliged to organize, upon a very considerable scale, the work of collecting these insects.

The enormous amount of work connected with the locating, collecting and holding in hibernation, the boxing, crating, shipping and distributing of several tons of live insects is little realized by the average reader. The illustrations accompanying this article, together with the following, will give some idea of how this work is conducted:

Starting about November 1st, the field men go up into the mountains to locate the hibernating colonies, which are usually found among pine-needles on sunny, well-drained slopes, usually in close proximity to running water. They are securely hidden, and inexperienced collectors may pass and repass directly over such spots and the presence of the colony will never be detected. In fact, the idea generally prevails in the minds of the mountain residents that the beetles come to the sections in the spring, and the idea is scouted that colonies of beetles spend the winter under the snow.

At this season, however, only a few of the beetles, relatively speaking, are discoverable. They are the first arrivals which have sought winter quarters early, but later on the colonies thus started rapidly grow in size. Other ladybirds join them, probably attracted by a peculiar insect odor, which they recognize, and so in the course of a few weeks immense numbers assemble.

Just how these over-wintering colonies are located, if explained, would hardly be believed by the general reading public. In fact, it is a sort of sense that is hardly subject to analysis. Our field men know, by past experience, where the most likely places are, and how also to find the beetles. We can at least immediately tell where they are not, thus eliminating a great deal of unproductive territory from

the work constituting the preliminary scouting.

Whenever a colony is located, we dig into the pine-needles, moss, leaves, etc., and through past experience we are enabled to estimate about how many pounds the said colony will yield. A little map is then roughly drawn on a card, a tree is blazed marking this spot, and the colony numbered with a notation on the back of card, giving conditions, probable amount obtainable, together with any information the collector thinks would be useful.

It will be understood that the work above described is but the beginning of the real work of collecting, which starts the last of December and continues until the last of February. Our field men at that time again go into the mountains and establish a camp as a center of operations, and proceed to make collections from colonies previously located.

When practicable a mule is taken along from the camp to carry the ladybirds, two men usually working together, and with fairly good luck they will collect from 50 to 100 pounds of the beetles in a day.



Fig. 9. Collecting Ladybirds. Showing method of using sieve. Note the masses of ladybirds upon the rocks and rubbish.

Various methods of separating the ladybirds from the pine needles and debris have been tried out and discarded. The most successful arrangement, and the one now in use, has been a canvas sack, open at both ends, with a coarse mesh sieve sewed in one end of the sack, composed entirely of wire, the bottom of the sack being tied with a drawstring and securely fastened. The use of this is quickly seen when the men get to work, for the beetles are found in clustered masses, often as big as one's two fists, under the leaves and pine needles on the ground. Two men usually work together; one man scoops them up and throws them into the sieve, while the other man passes them through, rejecting as much of the vegetable and other debris as he can possibly get rid of.

When the sieve-sack is full they are



Fig. 10. A Single Shipment of Ladybirds. The crate holds 33,000 individuals and constitutes a colony for five acres of melons or orchard infested with aphids (plant lice).

transferred to ordinary flour sacks, securely fastened at the end, and laid out on the snow, later to be taken out via the mule pack train to the railroad.

Inasmuch as the colonies in December and January are usually buried beneath several feet of snow, it would not be pos-



Fig. 11. The Ladybirds (*Hippodamia convergens*) are Measured in a Chute-like grain. The machine is operated with slides and counts 33,000 at each operation. They are packed in excelsior.

sible to find them but for the maps previously made on the cards in the manner already described. Provided with these maps, our field men know just where to look and lose no time. Their task, however, is difficult and laborious.

Usually once a week a mule pack train comes over the mountain trail to the camp to bring supplies and to carry away the sacks of beetles which have been accumulated. By this means the insects are conveyed to the nearest railway station, which is a distance of about 12 miles, where a small building has been rented and equipped as a packing house. Here the crop is cleaned, put up in suitable packages, and made ready for the long hibernation.

Between the time that the field men return from the preliminary location and the time the real collecting begins, the insectary force, assisted by the field men, are busily engaged in making the shipping crates. Each one is 13 inches long, eight inches wide, and 12 inches deep, covered on two sides with fine mesh wire netting and loosely filled with dry, clean excelsior. These receptacles are eventually to contain the ladybird crop, and



Fig. 12. A Collector Coming into Camp with a Day's Catch. Each collector carries a sieve and wears rubber boots to keep out the snow.

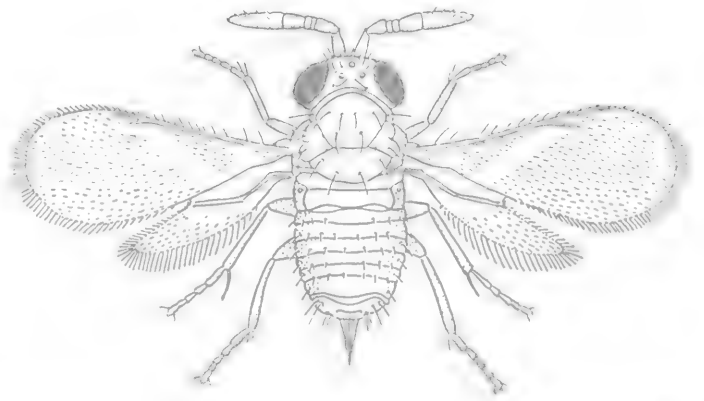

Fig. 13. The Golden Chalcid (*Aphelinus diaspidis* Howard [Family Eulophidae]). The adults are exceedingly small and delicate, bright yellow insects. Common throughout the south part of California, though it probably occurs in many central and northern sections. Parasitic upon red scale (*Chrysomphalus aurantii*) and rose scale (*Aulacaspis rosae*).

when completed they are shipped to the packing house in the mountains.

During the packing season one man is left in charge of the packing house, who attends to recleaning and resacking the insects. He then proceeds with the next step in the packing process, which is to pour the bugs from the sacks into an ingenious machine which counts them: they are counted, that is to say, by measurement. Dropping into a sort of hopper, made of tin and glass, they are measured as they pass through this machine (which is operated by a system of slides) into the shipping crates before mentioned.



Fig. 14. The Two-Stabbed Ladybird Beetle (*Chilocorus bivulnerus* Muls). The adults are broadly oval and about three-sixteenths of an inch long. The color is shiny black with two round blood-red spots upon the wing covers. The extreme margins of the prothorax are pale. The under side of the abdomen is red. The larvae are very shiny, dark in color, with a yellow transverse band across the middle. This is one of the native ladybird beetles and is to be found in almost every part of California. The larvae and adults are voracious feeders upon the San Jose scale (*Aspidiotus perniciosus*), young of the black scale (*Saissetia oleae*), mealy bugs (*Pseudococcus citri* and *P. longispinus*), oyster shell scale (*Lepidosaphes ulmi*), European elm scale (*Gossyparia spuria*) and other scale insects.

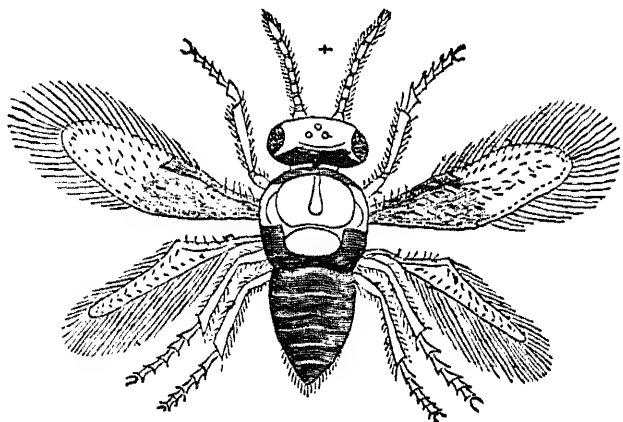

Fig. 15. The Purple Scale Parasite (*Aspidiotiphagus citrinus* Craw [Family Eulophidae]). An exceedingly small insect, almost microscopic in size, light and brownish yellow in color with wings, antennae and legs pale. Generally distributed throughout the purple scale-infested citrus districts in the southern part of California, but often limited or totally absent in certain localities. Works uncertainly but often very effectually on purple scale (*Lepidosaphes beckii*) in small localities, but of little consequence in controlling this pest. It also works on yellow scale (*Chrysonphalus citrinus*), red scale (*Chrysonphalus aurantii*), and pernicious scale (*Aspidiotus Perniciosus*).

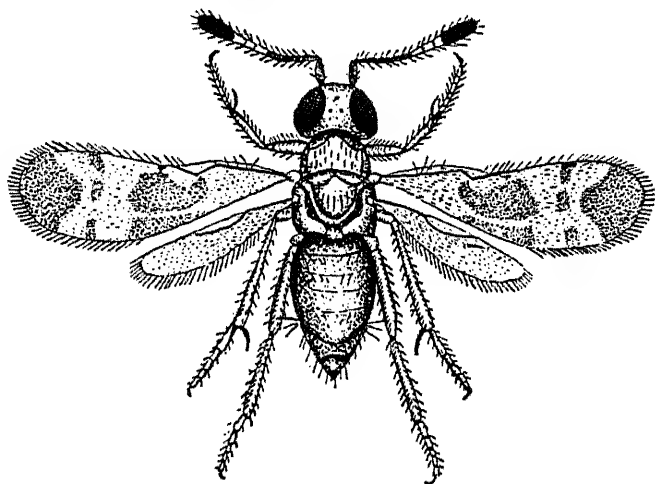

Fig. 16. Parasite of the Soft Brown Scale (*Encyrtus flavus* Howard [Family Encyrtidae]). A small parasite scarcely one-sixteenth of an inch long. The general color of the female is ochre; compound eyes brown; ocelli red; antennae yellow with tips black; the tips of the feet black. The basal third of the fore wings are clear with the remainder clouded with brown; the hind wings are clear. The males are considerably smaller than the females, and shiny metallic green in color with legs and antennae very light; wings clear with brown veins. Quite common throughout California, but especially abundant in the southern part. The soft brown scale (*Coccus hesperidum*) is often very effectually checked by its attacks.

The beetles are now in their final packages ready for distribution. But the time when they are needed will not arrive for six months, and meanwhile they must be kept alive and in first class condition. This, indeed, is the most difficult part of the whole business, the great problem being, as will be understood, to extend by artificial means, the natural hibernating period of the beetles in such a way that they may not lose any of their vitality.

In order that this may be accomplished they must be kept cold, without exposure to any marked change in temperature. If they are allowed to become warm, even for a little while, or moisture comes in contact with them, they will heat and cake into a solid mass, thus killing the entire colony in a remarkably short time.

A temperature slightly under 40 degrees Fahrenheit and plenty of ventilation is an absolute necessity, and the air must also be slightly moist, and the "crop" requires continual attention and at times the conditions must be changed quickly, or the entire lot will be lost.

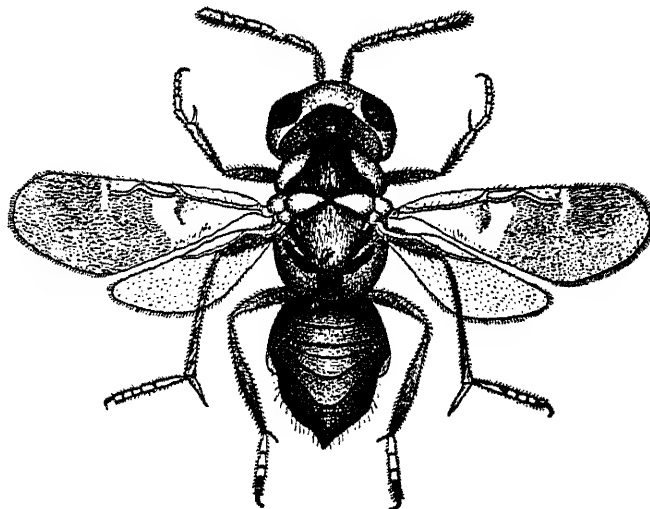

Fig. 17. Parasite of the Brown Apricot Scale (*Comys fusca* Howard [Family Encyrtidae]). The adults of this parasite are about one-eighth of an inch long and rich brown throughout in color. The wings are clouded with brownish markings, the bases remaining clear and when folded over the back, form a silverlike spot which is very noticeable when the insects are walking. The veins are black. The tips of the legs are yellowish with dark claws. One of the most common parasites occurring in all parts of California. Of all the internal parasites of scale insects this is one of the most efficient and is often quite a controlling factor in keeping down the brown apricot scale (*Lecanium corpi*).

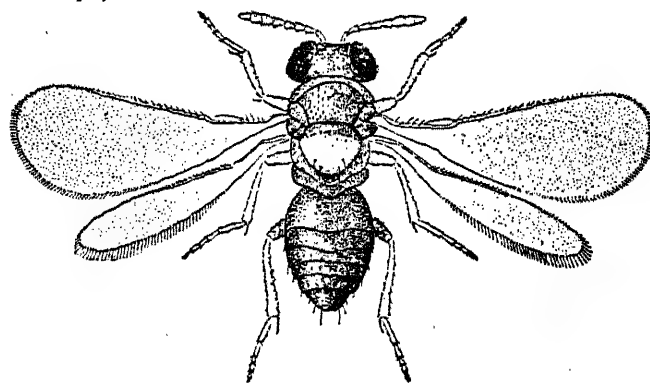

Fig. 18. Scale Parasite (*Coccophagus lecanii* Fitch [Family Eulophidae]). The adults are scarcely one-eighth of an inch long, dark bluish-black in color with a very noticeable and characteristic yellow scutellum. The antennae and the legs, excepting the dark femora, are amber. Exceedingly common throughout the entire southern and central parts of California. A very effective parasite on soft-brown scale (*Coccus hesperidum*), European fruit scale (*Lecanium corni*) and frosted scale (*Eulecanium prunosum*). In fact it may be reared from almost any of the members of the above genera.

The insects are packed in colonies on an average of 33,000 to each colony. They are distributed in various ways; the small individual colonies being sent direct to the applicants, while large consignments intended to cover an entire district, such as the Imperial valley, are usually preceded by an agent from the Insectary, who figures out the acreage and prorates the amount that can be supplied to each grower or association, and personally attends to the distributing of the colonies.

Last season's crop (1912) was exceptionally large, and when massed at the state Insectary, just prior to the actual shipping season, this lot of insect friends, combined with all the other various species of beneficial insects propagated at the Insectary, constituted what was undoubtedly the largest number of beneficial insects ever assembled at one place in the history of the world.

Many other species of ladybirds, both native and imported, are propagated, collected and distributed into the various fruit growing sections of California to assist our growers in maintaining the continuous warfare against the inroads of destructive forms.

Other species belonging to the *Hymenoptera* (four-winged flies) and *Diptera* (two-winged flies) have proven of incalculable benefit to the grower of fruit in this state, as well as various species of Syrphus flies, Lace-wing flies and Tachinid flies.

A few of the more important species, with explanatory notes accompanied by illustrations, will give a general idea of the scope of the work and the variety of forms handled.

The work of propagating the various species calls for ingenuity of the highest order in every case. With no precedent to be guided by, methods and apparatus have to be improvised as we go along. The artificial propagation work has not resolved itself into any systematic arrangement, except: Try to produce artificially, conditions as near natural as possible in which to propagate your species.

While the work of the California State Insectary has made wonderful progress in the few years it has been commercially established, we are only at the threshold of the science and undoubtedly the future will show even greater prog-

ress than has the past, at least, that is the sincere wish of the first and only superintendent of the California State Insectary.

The Codling Moth Parasite

Calliphialtes messor

This insect is a member of the Ichneumonidae, a parasitic family of the Hy-



Fig. 19. The Codling Moth Parasite (*Calliphialtes messor* Grav. [Family Ichneumonidae]). The minute eggs deposited in the cocoons of the codling moth are shiny white, almost transparent in color and long and narrow, with one end slightly enlarged. The adults are very active, four-winged parasites, averaging three-eighths of an inch in length, exclusive of the ovipositor which is slightly longer than the body in the females. The males are slightly smaller. The general color is black with reddish-yellow legs. The female, with her long ovipositor, inserts an egg into the cocoon of the codling moth. In a few days this egg hatches into a small, legless grub, which begins to feed upon the larva. The subsequent development is very rapid and at the end of from nine to sixteen days the larva spins a cocoon within the old shell and after another like period emerges as an adult. The males emerge first and await the females, when mating occurs and the life cycle repeated; the females continually searching for cocoons into which to deposit their supply of eggs. This parasite was discovered in Southern Europe by George Compere, who collected large numbers and sent them to the State Insectary some eight years ago. During this period the Insectary has been breeding and sending it out to all parts of California where the codling moth is a factor in fruit growing. It was especially thoroughly distributed in the central and southern parts. The larvae enclosed in the cocoons are the only stages of the codling moth attacked. These are carefully searched out by the females which have a wonderful instinct to locate them as well as to ascertain whether they have already been parasitized or not.

menoptera. Introduced from Europe, where it is a very effective check upon the codling moth (*Carpocapsa pomonella*), the apple worm.

Ichneumon species are the most difficult to establish of all our beneficial species, often requiring several years to become numerous enough to be of great benefit.

A large stock of this particular species is reared each year and distributed throughout the apple and pear growing sections of the state.

This is one of the most interesting species propagated at the Insectary and we hope to eventually establish it in all sections of the state. Marked results are expected from its introduction as soon as it can adjust itself to our unnatural conditions that at present prevail in our commercial orchards.

EDWARD K. CARNES

December 20, 1912.

Note—The etchings and descriptions in fine print of insects in this article are from the Monthly Bulletin of the California Commission of Horticulture, Vol. II, Nos. 1 and 2. The photos are by the author, except Fig. 19, which is from the above source—Editor.

Birds Useful To Farm and Orchard

Entomologists estimate that insects yearly cause a loss of over \$700,000,000 to the agriculture of the United States. Were it not for our birds, the loss would be very much greater, and it is doubtful if agriculture would be possible. A knowledge of the birds that protect the crops is therefore as important as a knowledge of the pests that destroy them. Such knowledge is the more important, because some birds are injurious, some are partly useful and partly injurious, and others, a few, are always useful. For instance, there are insects that are parasitic and predatory, feeding upon other insects that injure the crops, but insectivorous birds destroy the useful and harmful alike. However, the good they do by the destruction of harmful insects, is far greater than the harm they do by the destruction of useful kinds. Even the birds called noxious, possess some redeeming qualities and traits. Thus the crow is mischievous in spring, pulling up

the newly planted corn, and destroying the eggs of useful birds. But on the other hand, he eats insects, grubs, cut worms, meadow mice, gophers and other rodents, so that he is more useful than harmful.

Because their powers of flight enable them to gather rapidly at points where there are abnormal outbreaks of insects, birds are especially useful in protecting certain localities from scourges of grasshoppers and other pests; for an unusual number of insects in any particular locality attracts the birds, and they never leave until the insects are under control.

America is greatly favored in the number and character of its birds, which not only include some of the gems of the bird world, as warblers and humming birds, but on the whole embrace few destructive species. Not only do many birds satisfy our esthetic sense through their beautiful plumage and their sweet voices, but they are marvelously adapted to their respective fields of activity. No other creatures are so well fitted to capture flying insects as swallows, swifts and nighthawks. Among the avian ranks also are wrens, trim of body and agile of movement, that creep in and out of holes and crevices and explore rubbish heaps for hidden insects. The woodpecker, whose whole body exhibits wonderful adaptation of means to an end, is provided with strong claws for holding firmly when at work, a chisel-like bill driven by powerful muscles to dig out insects, and a long extensible tongue to still further explore the hidden retreats of insects and drag forth the concealed larvae, safe from other foes. The creepers, titmice, warblers, flycatchers, quails, doves, and other families have each their own special field of activity. However unlike they may be in appearance, structure, and habits, all are similar in one respect—they possess a never flagging appetite for insects and weed seeds.

One of the most useful groups of native birds is the sparrow family. While some of the tribe wear gay suits of many hues, most of the sparrows are clad in modest brown tints, and as they spend much of

the time in grass and weeds are commonly overlooked. Unobtrusive as they are, they lay the farmer under a heavy debt of gratitude by their food habits, since their chosen fare consists largely of the seeds of weeds. Selecting a typical member of the group, the tree sparrow, for instance, one-fourth ounce of weed seed per day is a conservative estimate of the food of an adult. On this basis, in a large agricultural state like Iowa tree sparrows annually eat approximately 875 tons of weed seeds. Only the farmer, upon whose shoulders falls the heavy burden of freeing his land of noxious weeds, can realize what this vast consumption of weed seeds means in the saving and cost of labor. Some idea of the money value of this group of birds to the country may be gained from the statement that the total value of the farm products in the United States in 1910 reached the amazing sum of \$8,926,000,000. If we estimate that the total consumption of weed seed by the combined members of the sparrow family resulted in a saving of only one per cent of the crops—not a violent assumption—the sum saved to farmers by these birds in 1910 was \$89,260,000.

The current idea in relation to hawks and owls is erroneous. These birds are generally classed as thieves and robbers, whereas a large majority of them are the farmer's friends and spend the greater part of their long lives in pursuit of injurious insects and rodents. The hawks work by day, the owls chiefly by night, so that the useful activities of the two classes are continued practically throughout the 24 hours. As many as 100 grasshoppers have been found in the stomach of a Swainson's hawk, representing a single meal; and in the retreat of a pair of barn owls have been found more than 3,000 skulls, 97 per cent of which were of mammals, the bulk consisting of field mice, house mice and common rats. Nearly half a bushel of the remains of pocket gophers—animals which are very destructive in certain parts of the United States—was found near a nest of this species. The notable increase of noxious rodents during

the last few years in certain parts of the United States and the consequent damage to crops are due in no small part to the diminished number of birds of prey, which formerly destroyed them and aided in keeping down their numbers. A few hawks are injurious, and the bulk of the depredations on birds and chickens chargeable against hawks is committed by three species—the cooper's hawk, the sharp-shinned hawk, and the goshawk. The farmer's boy should learn to know these daring robbers by sight, so as to kill them whenever possible.

From the foregoing it will at once appear that the practice of offering bounties indiscriminately for the heads of hawks and owls, as has been done by some States, is a serious mistake, the result being not only a waste of public funds but the destruction of valuable birds which can be replaced, if at all, only after the lapse of years.

As a rule birds do not live very long, but they live fast. They breathe rapidly and have a higher temperature and a more rapid circulation than other vertebrates. This is a fortunate circumstance, since to generate the requisite force to sustain their active bodies a large quantity of food is necessary, and as a matter of fact birds have to devote most of their waking hours to obtaining insects, seeds, berries, and other kinds of food. The activity of birds in the pursuit of insects is still further stimulated by the fact that the young of most species, even those which are by no means strictly insectivorous, require great quantities of animal food in the early weeks of existence, so that during the summer months—the flood time of insect life—birds are compelled to redouble their attacks on our insect foes to satisfy the wants of their clamorous young.

Field observations of the food habits of birds serve a useful purpose, but they are rarely accurate enough to be fully reliable. The presence of certain birds in a corn or wheat field or in an orchard is by no means proof, as is too often assumed, that they are devastating the grain or fruit. They may have been at-

tracted by insects which, unknown to the farmer or orchardist, are fast ruining his crop. Hence it has been found necessary to examine the stomachs and crops of birds to ascertain definitely what and how much they eat. The Biological Survey has in this way examined upward of 50,000 birds, most of which have been obtained during the last 25 years from scientific collectors, for our birds are too useful to be sacrificed when it can possibly be avoided, even for the sake of obtaining data upon which to base legislation for their protection.

It is interesting to observe that hungry birds—and birds are hungry most of the time—are not content to fill their stomachs with insects or seeds, but after the stomach is stuffed until it will hold no more continue to eat till the crop or gullet also is crammed. It is often the case that when the stomach is opened and the contents piled up the pile is two or three times as large as the stomach was when filled. Birds may truly be said to have healthy appetites. To show the astonishing capacity of birds' stomachs and to reveal the extent to which man is indebted to birds for the destruction of noxious insects, the following facts are given as learned by stomach examinations made by assistants of the Biological Survey:

A tree swallow's stomach was found to contain 40 entire chinch bugs and fragments of many others, besides 10 other species of insects. A bank swallow in Texas devoured 68 cotton-boll weevils, one of the worst insect pests that ever invaded the United States and 35 cliff swallows had taken an average of 18 boll weevils each. Two stomachs of pine siskins from Haywards, Cal., contained 1,900 black olive scales and 300 plant lice. A killdeer's stomach taken in November in Texas contained over 300 mosquito larvae. A flicker's stomach held 28 white grubs. A nighthawk's stomach collected in Kentucky contained 34 May beetles, the adult form of white grubs. Another nighthawk from New York had eaten 24 clover-leaf weevils and 375 ants. Still another nighthawk had eaten 340

grasshoppers, 52 bugs, 3 beetles, 2 wasps and a spider. A boat-tailed grackle from Texas had eaten at one meal about 100 cotton bollworms, besides a few other insects. A ring-necked pheasant's crop from Washington contained 8,000 seeds of chickweed and a dandelion head. More than 72,000 seeds have been found in a single duck stomach taken in Louisiana in February.

A knowledge of his bird friends and enemies, therefore, is doubly important to the farmer and orchardist in order that he may protect the kinds that earn protection by their services and may drive away or destroy the others. At the present time many kinds of useful birds need direct intervention in their behalf as never before. The encroachments of civilization on timbered tracts and the methods of modern intensive cultivation by destroying or restricting breeding grounds of birds tend to diminish their ranks. The number of insect pests, on the other hand, is all the time increasing by leaps and bounds through importations from abroad and by migration from adjoining territories. Every effort, therefore, should be made to augment the numbers of our useful birds by protecting them from their enemies, by providing nesting facilities, and by furnishing them food in times of stress, especially in winter.

Important in this connection is the planting near the house and even in out-of-the-way places on the farm of various berry-bearing shrubs, many of which are ornamental, which will supply food when snow is on the ground. Other species which are not berry eaters, like the woodpeckers, nuthatches, creepers, and chickadees, can be made winter residents of many farms, even in the North, by putting out at convenient places a supply of suet, of which they and many other birds are very fond, even in summer. Hedges and thickets about the farm are important to furnish nesting sites and shelter both from the elements and from the numerous enemies of birds.

Few are aware of the difficulty often experienced by birds in obtaining water

for drinking and bathing, and a constant supply of water near the farmhouse will materially aid in attracting birds to the neighborhood and in keeping them there, at least till the time of migration. Shallow trays of wood or metal admirably serve the purpose, especially as birds delight to bathe in them.

Considerable success has been met with in Germany and elsewhere in Europe by supplying artificial nest boxes for birds, and the same method of increasing the number of birds and attracting them to farms and orchards where their services are most needed should be extensively employed in this country. The experiment can the more easily be tried since several firms in the United States are now prepared to make and deliver boxes specially designed for martins, swallows, bluebirds, wrens, woodpeckers, and other species. The average farmer's boy, however, if provided with a few tools, is quite equal to the task of making acceptable boxes for the commoner species, which are far from fastidious as to the appearance of the box intended for their occupancy.

One of the worst foes of our native birds is the house cat, and probably none of our native wild animals destroys as many birds on the farm, particularly fledglings, as cats. The household pet is by no means blameless in this respect, for the bird-hunting instinct is strong even in the well-fed tabby; but much of the loss of our feathered life is attributable to the half-starved stray, which in summer is as much at home in the groves and fields as the birds themselves. Forced to forage for their own livelihood, these animals, which are almost as wild as the ancestral wildcat, inflict an appalling loss on our feathered allies and even on the smaller game birds like the woodcock and bobwhite. If cats are to find place in the farmer's household every effort should be made by careful feeding and watching them to insure the safety of the birds. The cat without a home should be mercifully put out of the way.

In the present article 50 of our com-

moner birds are discussed, including some that are destructive. They inhabit various parts of the country, and it is for the interest of the farmers of the respective localities to be familiar with them. The accounts of the birds' habits are necessarily brief, but they are believed to be sufficient to acquaint the reader with the most prominent characteristics of the several species, at least from the standpoint of their relation to man.

Bluebird

Sialia sialis

Length,* about six and one-half inches.

Range

Breeds in the United States (west to Arizona, Colorado, Wyoming, and Montana), Southern Canada, Mexico, and Guatemala; winters in the southern half of the Eastern United States and south to Guatemala.

Habits and Economic Status

The bluebird is one of the most familiar tenants of the farm and doorway. This bird, like the robin, phoebe, house wren, and some swallows, is very domestic in its habits. Its favorite nesting sites are crannies in the farm buildings or boxes made for its use or natural cavities in old apple trees. For rent the bird pays amply by destroying insects, and it takes no toll from the farm crop. The bluebird's diet consists of 68 per cent of insects to 32 per cent of vegetable matter. The largest items of insect food are grasshoppers first and beetles next, while caterpillars stand third. All of these are harmful except a few of the beetles. The vegetable food consists chiefly of fruit pulp, only an insignificant portion of which is of cultivated varieties. Among wild fruits elderberries are the favorite. From the above it will be seen that the bluebird does no essential harm, but eats many harmful and annoying insects.

Robin

Planesticus migratorius

Length, 10 inches.

* Measured from tip of bill to tip of tail

Range

Breeds in the United States (except the Gulf states), Canada, Alaska, and Mexico; winters in most of the United States and south to Guatemala.

Habits and Economic Status

In the North and some parts of the West the robin is among the most cherished of our native birds. The robin is an omnivorous feeder, and its food includes many orders of insects, with no very pronounced preference for any. It is very fond of earthworms, but its real economic status is determined by the vegetable food, which amounts to about 58 per cent of all. The principal item is fruit, which forms more than 51 per cent of the total food. The fact that in the examination of over 1,200 stomachs the percentage of wild fruit was found to be 5 times that of the cultivated varieties suggests that berry-bearing shrubs, if planted near the orchard, will serve to protect more valuable fruits. The bird's general usefulness is such, however, that all reasonable means of protecting orchard fruit should be tried before killing the birds.

Russet-Backed Thrush

Hyllocichla ustulata

Length, seven and one-fourth inches. Among thrushes having the top of head and tail nearly the same color as the back, this one is distinguished by its tawny eye ring and cheeks. The Pacific coast subspecies is russet brown above, while the other subspecies is the olive-backed thrush. The remarks below apply to the species as a whole.

Range

Breeds in the forested parts of Alaska and Canada and south to California, Colorado, Michigan, New York, West Virginia (mountains), and Maine; winters from Mexico to South America.

Habits and Economic Status

This is one of a small group of thrushes the members of which are by many ranked first among American songbirds. The several members resemble one another in size, plumage, and habits. While this thrush is very fond of fruit, its

partiality for the neighborhood of streams keeps it from frequenting orchards far from water. It is most troublesome during the cherry season, when the young are in the nest. From this it might be inferred that the young are fed on fruit, but such is not the case. The adults eat fruit, but the nestlings, as usual, are fed mostly upon insects. Beetles constitute the largest item of animal food, and ants come next. Many caterpillars also are eaten. The great bulk of vegetable food consists of fruit, of which two-fifths is of cultivated varieties. Where these birds live in or near gardens or orchards, they may do considerable damage, but they are too valuable as insect destroyers to be killed if the fruit can be protected in any other way.

Ruby-Crowned Kinglet

Regulus calendula

Length, about four and one-fourth inches. Olive green above, soiled whitish below, concealed feathers on head (crest) bright red.

Range

Breeds in Southern Canada, Southern Alaska, and the higher mountains of the Western United States; winters in much of the United States and south to Guatemala.

Habits and Economic Status

In habits and haunts this tiny sprite resembles a chickadee. It is an active, nervous little creature, flitting hither and yon in search of food, and in spring stopping only long enough to utter its beautiful song, surprisingly loud for the size of the musician. Three-fourths of its food consists of wasps, bugs, and flies. Beetles are the only other item of importance (12 per cent). The bugs eaten by the kinglet are mostly small, but, happily, they are the most harmful kinds. Tree hoppers, leaf hoppers, and jumping plant lice are pests and often do great harm to trees and smaller plants, while plant lice and scale insects are the worst scourges of the fruit grower—in fact, the prevalence of the latter has almost risen to the magnitude of a national peril. It is these small and seemingly insignificant birds that most successfully attack and

hold in check these insidious foes of horticulture. The vegetable food consists of seeds of poison ivy, or poison oak, a few weed seeds, and a few small fruits, mostly elderberries.

Chickadee

Penthestes atricapillus

Length, about five and one-fourth inches.

Range

Resident in the United States (except the southern half east of the plains), Canada and Alaska.

Habits and Economic Status

Because of its delightful notes, its confiding ways, and its fearlessness, the chickadee is one of our best-known birds. It responds to encouragement, and by hanging within its reach a constant supply of suet the chickadee can be made a regular visitor to the garden and orchard. Though insignificant in size, titmice are far from being so from the economic standpoint, owing to their numbers and activity. While one locality is being scrutinized for food by a larger bird, 10 are being searched by the smaller species. The chickadee's food is made up of insects and vegetable matter in the proportion of 7 of the former to 3 of the latter. Moths and caterpillars are favorites and form about one-third of the whole. Beetles, ants, wasps, bugs, flies, grasshoppers, and spiders make up the rest. The vegetable food is composed of seeds, largely those of pines, with a few of the poison ivy and some weeds. There are few more useful birds than the chickadees.

White-Breasted Nuthatch

Sitta carolinensis

Length, six inches. White below, above gray, with a black head.

Range

Resident in the United States, Southern Canada and Mexico.

Habits and Economic Status

This bird might readily be mistaken by a careless observer for a small woodpecker, but its note, an oft-repeated *yank*, is very unwoodpecker-like, and, unlike either woodpeckers or creepers it climbs

downward as easily as upward and seems to set the laws of gravity at defiance. The name was suggested by the habit of wedging nuts, especially beechnuts, in the crevices of bark so as to break them open by blows from the sharp, strong bill. The nuthatch gets its living from the trunks and branches of trees, over which it creeps from daylight to dark. Insects and spiders constitute a little more than 50 per cent of its food. The largest items of these are beetles, moths, and caterpillars, with ants and wasps. The animal food is all in the bird's favor except a few ladybird beetles. More than half of the vegetable food consists of mast, i. e., acorns and other nuts or large seeds. One-tenth of the food is grain, mostly waste corn. The nuthatch does no injury, so far as known, and much good.

Brown Creeper

Certhia familiaris americana and other subspecies

Length five and one-half inches.

Range

Breeds from Nebraska, Indiana, North Carolina (mountains), and Massachusetts north to Southern Canada, also in the mountains of the Western United States, north to Alaska, south to Nicaragua; winters over most of its range.

Habits and Economic Status

Rarely indeed is the creeper seen at rest. It appears to spend its life in an incessant scramble over the trunks and branches of trees, from which it gets all its food. It is protectively colored so as to be practically invisible to its enemies and, though delicately built, possesses amazingly strong claws and feet. Its tiny eyes are sharp enough to detect insects so small that most other species pass them by, and altogether the creeper fills a unique place in the ranks of our insect destroyers. The food consists of minute insects and insects' eggs, also cocoons of tineid moths, small wasps, ants, and bugs, especially scales and plant lice, with some small caterpillars. As the creeper remains in the United States throughout the year, it naturally secures

hibernating insects and insects' eggs, as well as spiders and spiders' eggs, that are missed by the summer birds. On its bill of fare we find no product of husbandry nor any useful insects.

House Wren

Troglodytes aedon

Length, four and three-fourths inches. The only one of our wrens with wholly whitish underparts that lacks a light line over the eye.

Range

Breeds throughout the United States (except the South Atlantic and Gulf states) and Southern Canada; winters in the Southern United States and Mexico.

Habits and Economic Status

The rich, bubbling song of the familiar little house wren is one of the sweetest associations connected with country and suburban life. Its tiny body, long bill, sharp eyes, and strong feet peculiarly adapt it for creeping into all sorts of nooks and crannies where lurk the insects it feeds on. A cavity in a fence post, a hole in a tree, or a box will be welcomed alike by this busybody as a nesting site; but since the advent of the quarrelsome English sparrow such domiciles are at a premium and the wren's eggs and family are safe only in cavities having entrances too small to admit the sparrow. Hence it behooves the farmer's boy to provide boxes the entrances to which are about an inch in diameter, nailing these under gables of barns and outhouses or in orchard trees. In this way the numbers of this useful bird can be increased, greatly to the advantage of the farmer. Grasshoppers, beetles, caterpillars, bugs, and spiders are the principal elements of its food. Cutworms, weevils, ticks, and plant lice are among the injurious forms eaten. The nestlings of house wrens consume great quantities of insects.

Brown Thrasher

Toxostoma rufum

Length, about 11 inches. Brownish red above, heavily streaked with black below.

Range

Breeds from the Gulf states to Southern Canada and west to Colorado, Wyoming, and Montana; winters in the southern half of the Eastern United States.

Habits and Economic Status

The brown thrasher is more retiring than either the mocking bird or catbird, but like them, is a splendid singer. Not infrequently, indeed, its song is taken for that of its more famed cousin, the mocking bird. It is partial to thickets and gets much of its food from the ground. Its search for this is usually accompanied by much scratching and scattering of leaves; whence its common name. Its call note is a sharp sound like the smacking of lips, which is useful in identifying this long-tailed, thicket-haunting bird, which does not much relish close scrutiny. The brown thrasher is not so fond of fruit as the catbird and mocker, but devours a much larger percentage of animal food. Beetles form one-half of the animal food, grasshoppers and crickets one-fifth, caterpillars, including cutworms, somewhat less than one-fifth, and bugs, spiders, and millipeds comprise most of the remainder. The brown thrasher feeds on such coleopterous pests as wire worms, May beetles, rice weevils, rose beetles, and figeaters. By its destruction of these and other insects, which constitute more than 60 per cent of its food, the thrasher much more than compensates for that portion (about one-tenth) of its diet derived from cultivated crops.

Catbird

Dumetella carolinensis

Length, about nine inches. The slaty gray plumage and black cap and tail are distinctive.

Range

Breeds throughout the United States west to New Mexico, Utah, Oregon and Washington, and in Southern Canada; winters from the Gulf states to Panama.

Habits and Economic Status

In many localities the catbird is one of the commonest birds. Tangled growths are its favorite nesting places and re-

treats, but berry patches and ornamental shrubbery are not disdained. Hence the bird is a familiar dooryard visitor. The bird has a fine song, unfortunately marred by occasional cat calls. With habits similar to those of the mocking bird and a song almost as varied, the catbird has never secured a similar place in popular favor. Half of its food consists of fruit, and the cultivated crops most often injured are cherries, strawberries, raspberries and blackberries. Beetles, ants, crickets and grasshoppers are the most important element of its animal food. The bird is known to attack a few pests, as cutworms, leaf beetles, clover-root curculio, and the periodical cicada, but the good it does in this way probably does not pay for the fruit it steals. The extent to which it should be protected may perhaps be left to the individual cultivator; that is, it should be made lawful to destroy catbirds that are doing manifest damage to crops.

Mocking Bird

Mimus polyglottos

Length, 10 inches. Most easily distinguished from the similarly colored loggerhead shrike by the absence of a conspicuous black stripe through the eye.

Range

Resident from Southern Mexico north to California, Wyoming, Iowa, Ohio and Maryland; casual farther north.

Habits and Economic Status

Because of its incomparable medleys and imitative powers, the mocking bird is the most renowned singer of the Western hemisphere. Even in confinement it is a masterly performer, and formerly thousands were trapped and sold for cage birds, but this reprehensible practice has been largely stopped by protective laws. It is not surprising, therefore, that the mocking bird should receive protection principally because of its ability as a songster and its preference for the vicinity of dwellings. Its place in the affections of the South is similar to that occupied by the robin in the North. It is well that this is true, for the bird appears not to earn protection from a

strictly economic standpoint. About half of its diet consists of fruit, and many cultivated varieties are attacked, such as oranges, grapes, figs, strawberries, blackberries and raspberries. Somewhat less than a fourth of the food is animal matter, and grasshoppers are the largest single element. The bird is fond of cotton worms, and is known to feed also on the chinch bug, rice weevil and bollworm. It is unfortunate that it does not feed on injurious insects to an extent sufficient to offset its depredations on fruit.

Myrtle Warbler

Dendroica coronata

Length, five and one-half inches. The similarly colored Audubon's warbler has a yellow throat instead of a white one

Range

Breeds throughout most of the forested area of Canada and south to Minnesota, Michigan, New York and Massachusetts; winters in the southern two-thirds of the United States and south to Panama.

Habits and Economic Status

This member of our beautiful wood warbler family, a family peculiar to America, has the characteristic voice, coloration and habits of its kind. Trim of form and graceful of motion, when seeking food it combines the methods of the wrens, creepers and flycatchers. It breeds only in the northern parts of the Eastern United States, but in migration it occurs in every patch of woodland and is so numerous that it is familiar to every observer. Its place is taken in the West by Audubon's warbler. More than three-fourths of the food of the myrtle warbler consists of insects, practically all of them harmful. It is made up of small beetles, including some weevils, with many ants and wasps. This bird is so small and nimble that it successfully attacks insects too minute to be prey for larger birds. Scales and plant lice form a very considerable part of its diet. Flies are the largest item of food; in fact, only a few flycatchers and swallows eat as many flies as this bird. The vegetable food (22 per cent) is made up of fruit

and the seeds of poison oak or ivy, also the seeds of pine and of the bayberry.

Loggerhead Shrike

Lanius ludovicianus

Length, about nine inches. A gray, black and white bird, distinguished from the somewhat similarly colored mocking bird by the black stripe on side of head.

Range

Breeds throughout the United States, Mexico and Southern Canada, winters in the southern half of the United States and in Mexico.

Habits and Economic Status

The loggerhead shrike, or Southern butcher bird, is common throughout its range and is sometimes called "French mocking bird" from a superficial resemblance and not from its notes, which are harsh and unmusical. The shrike is naturally an insectivorous bird which has extended its bill of fare to include small mammals, birds and reptiles. Its hooked beak is well adapted to tearing its prey, while to make amends for the lack of talons it has hit upon the plan of forcing its victim, if too large to swallow, into the fork of a bush or tree, where it can tear it asunder. Insects, especially grasshoppers, constitute the larger part of its food, though beetles, moths, caterpillars, ants, wasps and a few spiders also are taken. While the butcher bird occasionally catches small birds, its principal vertebrate food is small mammals, as field mice, shrews, and moles, and when possible it obtains lizards. It habitually impales its surplus prey on a thorn, sharp twig, or barb of a wire fence.

Barn Swallow

Hirundo erythrogastra

Length, about seven inches. Distinguished among our swallows by deeply forked tail.

Range

Breeds throughout the United States (except the South Atlantic and Gulf states) and most of Canada; winters in South America.

Habits and Economic Status

This is one of the most familiar birds of the farm and one of the greatest insect destroyers. From daylight to dark on tireless wings it seeks its prey, and the insects destroyed are countless. Its favorite nesting site is a barn rafter, upon which it sticks its mud basket. Most modern barns are so tightly constructed that swallows cannot gain entrance, and in New England and some other parts of the country barn swallows are much less numerous than formerly. Farmers can easily provide for the entrance and exit of the birds and so add materially to their numbers. It may be well to add that the parasites that sometimes infest the nests of swallows are not the ones the careful housewife dreads, and no fear need be felt of the infestation spreading to the houses. Insects taken on the wing constitute the almost exclusive diet of the barn swallow. More than one-third of the whole consists of flies, including unfortunately some useful parasitic species. Beetles stand next in order and consist of a few weevils and many of the small dung beetles of the May beetle family that swarm over the pastures in the late afternoon. Ants amount to more than one-fifth of the whole food, while wasps and bees are well represented.

Purple Martin

Progne subis

Length, about eight inches.

Range

Breeds throughout the United States and Southern Canada, south to Central Mexico; winters in South America.

Habits and Economic Status

This is the largest as it is one of the most beautiful of the swallow tribe. It formerly built its nests in cavities of trees, as it still does in wild districts, but learning that man was a friend it soon adopted domestic habits. Its presence about the farm can often be secured by erecting houses suitable for nesting sites and protecting them from usurpation by the English sparrow, and every effort should be made to increase the

number of colonies of this very useful bird. The boxes should be at a reasonable height, say 15 feet from the ground, and made inaccessible to cats. A colony of these birds on a farm makes great inroads upon the insect population, as the birds not only themselves feed upon insects but rear their young upon the same diet. Fifty years ago in New England it was not uncommon to see colonies of 50 pairs of martins, but most of them have now vanished for no apparent reason except that the martin houses have decayed and have not been renewed. More than three-fourths of this bird's food consists of wasps, bugs, and beetles, their importance being in the order given. The beetles include several species of harmful weevils, as the clover-leaf weevils and the nut weevils. Besides these are many crane flies, moths, May flies, and dragon flies.

Black-Headed Grosbeak

Zamelodia melanocephala

Length, about eight and one-fourth inches.

Range

Breeds from the Pacific coast to Nebraska and the Dakotas, and from Southern Canada to Southern Mexico; winters in Mexico.

Habits and Economic Status

The black-headed grosbeak takes the place in the West of the rosebreast in the East, and like it is a fine songster. Like it also the blackhead readily resorts to orchards and gardens and is common in agricultural districts. The bird has a very powerful bill and easily crushes or cuts into the firmest fruit. It feeds upon cherries, apricots and other fruits, and also does some damage to green peas and beans, but it is so active a foe of certain horticultural pests that we can afford to overlook its faults. Several kinds of scale insects are freely eaten, and one, the black olive scale, constitutes a fifth of the total food. In May many canker worms and codling moths are consumed, and almost a sixth of the bird's seasonal food consists of flower beetles, which do incalculable damage to cultivated flowers and to ripe fruit. For each quart of

fruit consumed by the black-headed grosbeak it destroys in actual bulk more than one and one-half quarts of black olive scales and one quart of flower beetles, besides a generous quantity of codling moth pupae and cankerworms. It is obvious that such work as this pays many times over for the fruit destroyed

Rose-Breasted Grosbeak

Zamelodia ludoviciana

Length, eight inches

Range

Breeds from Kansas, Ohio, Georgia (mountains), and New Jersey, north to Southern Canada, winters from Mexico to South America.

Habits and Economic Status

This beautiful grosbeak is noted for its clear, melodious notes, which are poured forth in generous measure. The rosebreast sings even at midday during summer, when the intense heat has silenced almost every other songster. Its beautiful plumage and sweet song are not its sole claim on our favor, for few birds are more beneficial to agriculture. The rosebreast eats some green peas and does some damage to fruit. But this mischief is much more than balanced by the destruction of insect pests. The bird is so fond of the Colorado potato beetle that it has earned the name of "potato-bug bird," and no less than a tenth of the total food of the rosebreasts examined consists of potato beetles—evidence that the bird is one of the most important enemies of the pest. It vigorously attacks cucumber beetles and many of the scale insects. It proved an active enemy of the Rocky Mountain locust during that insect's ruinous invasions, and among the other pests it consumes are the spring and fall cankerworms, orchard and forest tent caterpillars, tussock, gipsy and brown-tail moths, plum curculio, army worm and chinch bug. In fact, not one of our birds has a better record.

Song Sparrow

Melospiza melodia

Length, about six and one-fourth inches. The heavily spotted breast with heavy central blotch is characteristic.

Range

Breeds in the United States (except the South Atlantic and Gulf states), Southern Canada, Southern Alaska, and Mexico, winters in Alaska and most of the United States southward.

Habits and Economic Status

Like the familiar little "chippy," the song sparrow is one of our most domestic species, and builds its nest in hedges or in garden shrubbery close to houses, whenever it is reasonably safe from the house cat, which, however, takes heavy toll of the nestlings. It is a true harbinger of spring, and its delightful little song is thrilled forth from the top of some green shrub in early March and April, before most of our other songsters have thought of leaving the sunny South. Song sparrows vary much in habits, as well as in size and coloration. Some forms live along streams bordered by deserts, others in swamps among bulrushes and tules, others in timbered regions, others on rocky barren hillsides, and still others in rich, fertile valleys. With such a variety of habitat, the food of the species naturally varies considerably. About three-fourths of its diet consists of the seeds of noxious weeds and one-fourth of insects. Of these, beetles, especially weevils, constitute the major portion. Ants, wasps, bugs (including the black olive scale), and caterpillars are also eaten. Grasshoppers are taken by the Eastern birds, but not by the Western ones.

Chipping Sparrow

Spizella passerina

Length, about five and one-fourth inches. Distinguished by the chestnut crown, black line through eye, and black bill.

Range

Breeds throughout the United States, south to Nicaragua, and north to Southern Canada; winters in the Southern United States and southward.

Habits and Economic Status

The chipping sparrow is very friendly and domestic, and often builds its nest in gardens and orchards or in the shrubbery close to dwellings. Its gentle and

confiding ways endear it to all bird lovers. It is one of the most insectivorous of all the sparrows. Its diet consists of about 42 per cent of insects and spiders and 58 per cent of vegetable matter. The animal food consists largely of caterpillars, of which it feeds a great many to its young. Besides these, it eats beetles, including many weevils, of which one stomach contained 30. It also eats ants, wasps, and bugs. Among the latter are plant lice and black olive scales. The vegetable food is practically all weed seed. A nest with four young of this species was watched at different hours on four days. In the seven hours of observation 119 feedings were noted, or an average of 17 feedings per hour, or four and one-half feedings per hour to each nestling. This would give for a day of 14 hours at least 238 insects eaten by the brood.

White-Crowned Sparrow

Zonotrichia leucophrys

Length, seven inches. The only similar sparrow, the white-throat, has a yellow spot in front of eye.

Range

Breeds in Canada, the mountains of New Mexico, Colorado, Wyoming and Montana, and thence to the Pacific coast; winters in the southern half of the United States and Northern Mexico.

Habits and Economic Status

This beautiful sparrow is much more numerous in the Western than in the Eastern states, where, indeed, it is rather rare. In the East it is shy and retiring, but it is much bolder and more conspicuous in the far West and there often frequents gardens and parks. Like most of its family it is a seed eater by preference, and insects comprise very little more than seven per cent of its diet. Caterpillars are the largest item, with some beetles, a few ants and wasps, and some bugs, among which are black olive scales. The great bulk of the food, however, consists of weed seeds, which amount to 74 per cent of the whole. In California this bird is accused of eating the buds and blossoms of fruit trees, but buds or blossoms were found in only 30 out of

516 stomachs, and probably it is only under exceptional circumstances that it does any damage in this way. Evidently neither the farmer nor the fruit grower has much to fear from the white-crowned sparrow. The little fruit it eats is mostly wild, and the grain eaten is waste or volunteer.

English Sparrow
Passer domesticus

Length, about six and one-fourth inches. Its incessant chattering, quarrelsome disposition, and abundance and familiarity about human habitations distinguish it from our native sparrows.

Range

Resident throughout the United States and Southern Canada.

Habits and Economic Status

Almost universally condemned since its introduction into the United States, the English sparrow has not only held its own, but has ever increased in numbers and extended its range in spite of all opposition. Its habit of driving out or even killing more beneficial species and the defiling of buildings by its droppings and by its own unsightly structures, are serious objections to this sparrow. Moreover, in rural districts, it is destructive to grain, fruit, peas, beans and other vegetables. On the other hand, the bird feeds to some extent on a large number of insect pests, and this fact points to the need of a new investigation of the present economic status of the species, especially as it promises to be of service in holding in check the newly introduced alfalfa weevil, which threatens the alfalfa industry in Utah and neighboring states. In cities most of the food of the English sparrow is waste material secured from the streets.

Crow Blackbird
Quiscalus quiscula

Length, 12 inches. Shorter by at least three inches than the other grackles with trough-shaped tails. Black, with purplish, bluish and bronze reflections.

Range

Breeds throughout the United States west to Texas, Colorado and Montana,

and in Southern Canada; winters in the southern half of the breeding range.

Habits and Economic Status

This blackbird is a beautiful species, and is well known from its habit of congregating in city parks and nesting there year after year. Like other species which habitually assemble in great flocks, it is capable of inflicting much damage on any crop it attacks, and where it is harmful a judicious reduction of numbers is probably sound policy. It shares with the crow and blue jay the evil habit of pillaging the nests of small birds of eggs and young. Nevertheless it does much good by destroying insect pests, especially white grubs, weevils, grasshoppers and caterpillars. Among the caterpillars are army worms and other cutworms. When blackbirds gather in large flocks, as in the Mississippi valley, they may greatly damage grain, either when first sown or when in the milk. In winter they subsist mostly on weed seed and waste grain.

Brewer's Blackbird
Euphagus cyanocephalus

Length, 10 inches. Its glossy purplish head distinguishes it from other blackbirds that do not show in flight a trough-shaped tail.

Range

Breeds in the West, east to Texas, Kansas and Minnesota, and north to Southern Canada; winters over most of the United States breeding range, south to Guatemala.

Habits and Economic Status

Very numerous in the West and in fall gathers in immense flocks, especially about barnyards and corrals. During the cherry season in California Brewer's blackbird is much in the orchards. In one case they were seen to eat freely of cherries, but when a neighboring fruit raiser began to plow his orchard almost every blackbird in the vicinity was upon the newly opened ground and close at the plowman's heels in its eagerness to get the insects exposed by the plow. Caterpillars and pupae form the largest item of animal food (about 12 per cent). Many of these are cutworms, and cotton

bollworms or corn earworms were found in 10 stomachs and codling moth pupae in 11. Beetles constitute over 11 per cent of the food. The vegetable food is practically contained in three items—grain, fruit and weed seeds. Grain, mostly oats, amounts to 54 per cent; fruit, largely cherries, four per cent; and weed seeds, not quite nine per cent. The grain is probably mostly wild, volunteer or waste, so that the bird does most damage by eating fruit.

Bullock's Oriole

Icterus bullocki

Length, about eight inches. Our only oriole with top of head and throat black and cheeks orange.

Range

Breeds from South Dakota, Nebraska and Kansas to the Pacific ocean and from Southern Canada to Northern Mexico; winters in Mexico.

Habits and Economic Status

In the West this bird takes the place occupied in the East by the Baltimore oriole. In food, nesting habits, and song the birds are similar. Both are migratory and remain on their summer range only some five or six months. They take kindly to orchards, gardens, and the vicinity of farm buildings and often live in villages and city parks. Their diet is largely made up of insects that infest orchards and gardens. When fruit trees are in bloom they are constantly busy among the blossoms and save many of them from destruction. In the food of Bullock's oriole beetles amount to 35 per cent and nearly all are harmful. Many of these are weevils, some of which live upon acorns and other nuts. Ants and wasps amount to 15 per cent of the diet. The black olive scale was found in 45 of the 162 stomachs examined. Caterpillars, with a few moths and pupae, are the largest item of food and amount to over 41 per cent. Among these were codling moth larvae. The vegetable food is practically all fruit (19 per cent) and in cherry season consists largely of that fruit. Eating small fruits is the bird's worst trait, but it will do harm in this way only when very numerous.

Meadowlarks

Sturnella magna and *Sturnella neglecta*

Length, about 10¾ inches.

Range

Breed generally in the United States, Southern Canada, and Mexico to Costa Rica; winter from the Ohio and Potomac valleys and British Columbia southward.

Habits and Economic Status

Our two meadowlarks, though differing much in song, resemble each other closely in plumage and habits. Grassy plains and uplands covered with a thick growth of grass or weeds, with nearby water, furnish the conditions best suited to the meadowlark's taste. The song of the Western bird is loud, clear and melodious. That of its Eastern relative is feebler and loses much by comparison. In many localities the meadowlark is classed and shot as a game bird. From the farmer's standpoint this is a mistake, since its value as an insect eater is far greater than as a game bird. Both the bollweevil, the foe of the cotton grower, and the alfalfa weevil are among the beetles it habitually eats. Twenty-five per cent of the diet of this bird is beetles, half of which are predaceous ground beetles, accounted useful insects, and one-fifth are destructive weevils. Caterpillars form 11 per cent of the food and are eaten in every month in the year. Among these are many cutworms and the well known army worm. Grasshoppers are favorite food and are eaten in every month and almost every day. The vegetable food (24 per cent of the whole) consists of grain and weed seeds.

Red-Winged Blackbird

Agelaius phoeniceus

Length, about nine and one-half inches.

Range

Breeds in Mexico and North America south of the Barren Grounds; winters in southern half of United States and south to Costa Rica.

Habits and Economic Status

The prairies of the upper Mississippi valley, with their numerous sloughs and ponds, furnish ideal nesting places for

redwings, and consequently this region has become the great breeding ground for the species. These prairies pour forth the vast flocks that play havoc with grainfields. East of the Appalachian range, marshes on the shores of lakes, rivers, and estuaries are the only available breeding sites and, as these are comparatively few and small, the species is much less abundant than in the West. Redwings are eminently gregarious, living in flocks and breeding in communities. The food of the redwing consists of 27 per cent animal matter and 73 per cent vegetable. Insects constitute practically one-fourth of the food. Beetles (largely weevils, a most harmful group) amount to 10 per cent. Grasshoppers are eaten in every month and amount to about five per cent. Caterpillars (among them the injurious army worm) are eaten at all seasons and aggregate six per cent. Ants, wasps, bugs, flies, dragon flies, and spiders also are eaten. The vegetable food consists of seeds, including grain, of which oats is the favorite, and some small fruits. When in large flocks this bird is capable of doing great harm to grain.

Bobolink

Dolichonyx oryzivorus

Length, about seven inches.

Range

Breeds from Ohio northeast to Nova Scotia, north to Manitoba, and northwest to British Columbia; winters in South America.

Habits and Economic Status

When American writers awoke to the beauty and attractiveness of our native birds, among the first to be enshrined in song and story was the bobolink. Few species show such striking contrasts in the color of the sexes, and few have songs more unique and whimsical. In its northern home the bird is loved for its beauty and its rich melody; in the South it earns deserved hatred by its destructiveness. Bobolinks reach the southeastern coast of the United States the last half of April just as rice is sprouting, and at once begin to pull up and devour the sprouting kernels. Soon they move on

to their northern breeding grounds, where they feed upon insects, weed seeds, and a little grain. When the young are well on the wing, they gather in flocks with the parent birds and gradually move southward, being then generally known as reed birds. They reach the rice fields of the Carolinas about August 20, when the rice is in the milk. Then, until the birds depart for South America, planters and birds fight for the crop, and in spite of constant watchfulness and innumerable devices for scaring the birds a loss of 10 per cent of the rice is the usual result.

Common Crow

Corvus brachyrhynchos

Length, 19 inches.

Range

Breeds throughout the United States and most of Canada; winters generally in the United States.

Habits and Economic Status

The general habits of the crow are universally known. Its ability to commit such misdeeds as pulling corn and stealing eggs and fruit and to get away unscathed is little short of marvelous. Much of the crow's success in life is due to cooperation, and the social instinct of the species has its highest expression in the winter roosts, which are sometimes frequented by hundreds of thousands of crows. From these roosts daily flights of many miles are made in search of food. Injury to sprouting corn is the most frequent complaint against this species, but by coating the seed grain with coal tar most of this damage may be prevented. Losses of poultry and eggs may be averted by proper housing and the judicious use of wire netting. The insect food of the crow includes wireworms, cutworms, white grubs, and grasshoppers, and during outbreaks of these insects the crow renders good service. The bird is also an efficient scavenger. But chiefly because of its destruction of beneficial wild birds and their eggs the crow must be classed as a criminal, and a reduction in its numbers in localities where it is seriously destructive is justifiable.

California Jay*Aphelocoma californica*

Length, 12 inches. Distinguished from other jays within its range by its decidedly whitish underparts and brown patch on the back.

Range

Resident in California, north to Southern Washington, and south to Southern Lower California.

Habits and Economic Status

This jay has the same general traits of character as the Eastern blue jay. He is the same noisy, rollicking fellow and occupies a corresponding position in bird society. Robbing the nests of smaller birds is a favorite pastime, and he is a persistent spy upon domestic fowls and well knows the meaning of the cackle of a hen. Not only does he steal eggs but he kills young chicks. The insect food of this jay constitutes about one-tenth of its annual sustenance. The inclusion of grasshoppers and caterpillars makes this part of the bird's food in its favor. But the remainder of its animal diet includes altogether too large a proportion of beneficial birds and their eggs, and in this respect it appears to be worse than its Eastern relative, the blue jay. While its vegetable food is composed largely of mast, at times its liking for cultivated fruit and grain makes it a most unwelcome visitor to the orchard and farm. In conclusion, it may be said that over much of its range this jay is too abundant for the best interests of agriculture and horticulture.

Blue Jay*Cyanocitta cristata*

Length, 11½ inches. The brilliant blue of the wings and tail combined with the black crescent of the upper breast and the crested head distinguish this species.

Range

Resident in the Eastern United States and Southern Canada, west to the Dakotas, Colorado and Texas.

Habits and Economic Status

The blue jay is of a dual nature. Cautious and silent in the vicinity of its

nest, away from it it is bold and noisy. Sly in the commission of mischief, it is ever ready to scream "thief" at the slightest disturbance. As usual in such cases, its remarks are applicable to none more than itself, a fact neighboring nest holders know to their sorrow, for during the breeding season the jay lays heavy toll upon the eggs and young of other birds, and in doing so deprives us of the services of species more beneficial than itself. Approximately three-fourths of the annual food of the blue jay is vegetable matter, the greater part of which is composed of mast, i. e., acorns, chestnuts, beechnuts, and the like. Corn is the principal cultivated crop upon which this bird feeds, but stomach analysis indicates that most of the corn taken is waste grain. Such noxious insects as wood-boring beetles, grasshoppers, eggs of various caterpillars, and scale insects constitute about one-fifth of its food.

Horned Lark*Otocoris alpestris*

Length, about seven and three-fourths inches. The black mark across the breast and the small, pointed tufts of dark feathers above and behind the eyes distinguish the bird.

Range

Breeds throughout the United States (except the South Atlantic and Gulf states) and Canada; winters in all the United States except Florida.

Habits and Economic Status

Horned larks frequent the open country, especially the plains and deserts. They associate in large flocks, are hardy, apparently delighting in exposed situations in winter, and often nest before snow disappears. The flight is irregular and hesitating, but in the breeding season the males ascend high in air, singing as they go, and pitch to the ground in one thrilling dive. The preference of horned larks is for vegetable food, and about one-sixth of this is grain, chiefly waste. Some sprouting grain is pulled, but drilled grain is safe from injury. California horned larks take much more grain than the Eastern birds, specializ-

ing on oats, but this is accounted for by the fact that oats grow wild over much of the state. Weed seeds are the largest single element of food. The insect food, about 20 per cent of the whole, includes such pests as May beetles and their larvae (white grubs), leaf beetles, clover-leaf and clover-root weevils, the potato-stalk borer, nut weevils, billbugs, and the chinch bug. Grasshoppers are a favorite food, and cutworms are freely eaten. The horned larks, on the whole, may be considered useful birds.

Arkansas Kingbird

Tyrannus verticalis

Length, nine inches. The white edge of the feather on each side of the tail distinguishes this from all other fly catchers except the gray and salmon-colored scissortail of Texas.

Range

Breeds from Minnesota, Kansas and Texas to the Pacific ocean and from Northern Mexico to Southern Canada; winters from Mexico to Guatemala.

Habits and Economic Status

The Arkansas kingbird is not so domestic as its Eastern relative and seems to prefer the hill country with scattered oaks rather than the orchard or the vicinity of ranch buildings, but it sometimes places its rude and conspicuous nest in trees on village streets. The bird's yearly food is composed of 87 per cent animal matter and 13 per cent vegetable. The animal food is composed almost entirely of insects. Like the Eastern species, it has been accused of destroying honeybees to a harmful extent, and remains of honeybees were found to constitute five per cent of the food of the individuals examined, but nearly all those eaten were drones. Bees and wasps, in general, are the biggest item of food (38 per cent), grasshoppers and crickets stand next (20 per cent), and beetles, mostly of noxious species, constitute 14 per cent of the food. The vegetable food consists mostly of fruit, such as the elder and other berries, with a few seeds. This bird should be strictly preserved.

Kingbird

Tyrannus tyrannus

Length, about eight and one-half inches. The white lower surface and white-tipped tail distinguish this fly catcher.

Range

Breeds throughout the United States (except the southwestern part) and Southern Canada; winters from Mexico to South America.

Habits and Economic Status

The kingbird is a pronounced enemy of hawks and crows, which it vigorously attacks at every opportunity, thereby affording efficient protection to nearby poultry yards and young chickens at large. It loves the open country and is especially fond of orchards and trees about farm buildings. No less than 85 per cent of its food consists of insects, mostly of a harmful nature. It eats the common rose chafer or rose bug, and more remarkable still it devours blister beetles freely. The bird has been accused of eating honeybees to an injurious extent, but there is little ground for the accusation, as appears from the fact that examination of 634 stomachs showed only 61 bees in 22 stomachs. Of these 51 were useless drones. On the other hand, it devours robber flies, which catch and destroy honeybees. Grasshoppers and crickets, with a few bugs and some cut worms, and a few other insects, make up the rest of the animal food. The vegetable food consists of fruit and a few seeds. The kingbird deserves full protection.

Nighthawk

Chordeiles virginianus

Length, 10 inches. Not to be confused with the whippoorwill. The latter lives in woodland and is chiefly nocturnal. The nighthawk often flies by day, when the white bar across the wing and its nasal cry are distinguishing.

Range

Breeds throughout most of the United States and Canada; winters in South America.

Habits and Economic Status

The skillful evolutions of a company of nighthawks as the birds gracefully cleave the air in intersecting circles is a sight to be remembered. So expert are they on the wing that no insect is safe from them, even the swift dragonfly being captured with ease. Unfortunately their erratic flight tempts men to use them for targets, and this inexcusable practice is seriously diminishing their numbers, which is deplorable, since no birds are more useful. This species makes no nest, but lays its two spotted eggs on the bare ground, sometimes on the gravel roof of the city house. The nighthawk is a voracious feeder and is almost exclusively insectivorous. Some stomachs contained from 30 to 50 different kinds of insects, and more than 600 kinds have been identified from the stomachs thus far examined. From 500 to 1,000 ants are often found in a stomach. Several species of mosquitoes, including *Anopheles*, the transmitter of malaria, are eaten. Other well known pests destroyed by the nighthawk are the Colorado potato beetle, cucumber beetles, chestnut, rice, clover-leaf and cotton-boll weevils, billbugs, bark beetles, squash bugs, and moths of the cotton worm.

Flicker

Colaptes auratus

Length, 13 inches. The yellow under surface of the wing, yellow tail shafts, and white rump are characteristic.

Range

Breeds in the Eastern United States west to the plains and in the forested parts of Canada and Alaska; winters in most of the Eastern United States.

Habits and Economic Status

The flicker inhabits the open country rather than the forest and delights in park-like regions where trees are numerous and scattered. It nests in any large cavity in a tree and readily appropriates an artificial box. It is possible, therefore, to insure the presence of this useful bird about the farm and to increase its numbers. It is the most terrestrial of our woodpeckers and procures much of

its food from the ground. The largest item of animal food is ants, of which the flicker eats more than any other common birds. Ants were found in 524 of the 684 stomachs examined and 98 stomachs contained no other food. One stomach contained over 5,000 and two others held over 3,000 each. While bugs are not largely eaten by the flicker, one stomach contained 17 chinch bugs. Wild fruits are next to ants in importance in the flicker's dietary. Of these sour gum and wild black cherry stand at the head. The food habits of this bird are such as to recommend it to complete protection.

Yellow-Bellied Sapsucker

Sphyrapicus varius

Length, about eight and one-half inches. Only woodpecker having top of head from base of bill red, combined with a black patch on breast.

Range

Breeds in northern half of the United States and southern half of Canada; winters in most of the states and south to Costa Rica.

Habits and Economic Status

The yellow-bellied sapsucker is rather silent and suspicious and generally manages to have a tree between himself and the observer. Hence the bird is much better known by its works than its appearance. The regular girdles of holes made by this bird are common on a great variety of trees; in all about 250 kinds are known to be attacked. Occasionally young trees are killed outright, but more loss is caused by stains and other blemishes in the wood which result from sapsucker punctures. These blemishes, which are known as bird pecks, are especially numerous in hickory, oak, cypress and yellow poplar. Defects due to sapsucker work cause an annual loss to the lumber industry estimated at \$1,250,000. The food of the yellow-bellied sapsucker is about half animal and half vegetable. Its fondness for ants counts slightly in its favor. It eats also wasps, beetles (including, however, very few wood-boring species), bugs, and spiders. The two principal components of the vegetable

food are wild fruits of no importance and cambium (the layer just beneath the bark of trees). In securing the cambium the bird does the damage above described. The yellow-bellied sapsucker, unlike other woodpeckers, thus does comparatively little good and much harm.

Downy Woodpecker

Dryobates pubescens

Length, six inches. Our smallest woodpecker; spotted with black and white. Dark bars on the outer tail feathers distinguish it from the similarly colored but larger hairy woodpecker.

Range

Resident in the United States and the forested parts of Canada and Alaska.

Habits and Economic Status

This woodpecker is commonly distributed, living in woodland tracts, orchards and gardens. The bird has several characteristic notes, and, like the hairy woodpecker, is fond of beating on a dry resonant tree branch a tattoo which to appreciative ears has the quality of woodland music. In a hole excavated in a dead branch the downy woodpecker lays four to six eggs. This and the hairy woodpecker are among our most valuable allies, their food consisting of some of the worst foes of orchard and woodland, which the woodpeckers are especially equipped to dig out of dead and living wood. In the examination of 723 stomachs of this bird, animal food, mostly insects, was found to constitute 76 per cent of the diet and vegetable matter 24 per cent. The animal food consists largely of beetles that bore into timber or burrow under the bark. Caterpillars amount to 16 per cent of the food and include many especially harmful species. Grasshopper eggs are freely eaten. The vegetable food of the downy woodpecker consists of small fruit and seeds, mostly of wild species. It distributes seeds of poison ivy, or poison oak, which is about the only fault of this very useful bird.

Yellow-Billed Cuckoo

Coccyzus americanus

Length, about 12 inches. The yellow lower part of the bill distinguishes this

bird from its near relative, the black-billed cuckoo.

Range

Breeds generally in the United States and Southern Canada; winters in South America.

Habits and Economic Status

This bird lives on the edges of woodland, in groves, orchards, parks, and even in shaded village streets. It is sometimes known as rain crow, because its very characteristic notes are supposed to foretell rain. The cuckoo has sly, furtive ways as it moves among the bushes or flits from tree to tree, and is much more often seen than heard. Unlike its European relative, it does not lay its eggs in other birds' nests, but builds a nest of its own. This is, however, a rather crude and shabby affair—hardly more than a platform of twigs sufficient to hold the greenish eggs. The cuckoo is extremely useful because of its insectivorous habits, especially as it shows a marked preference for the hairy caterpillars, which few birds eat. One stomach that was examined contained 250 American tent caterpillars; another, 217 fall webworms. In places where tent caterpillars are abundant they seem to constitute a large portion of the food of this and the black-billed cuckoo.

Screech Owl

Otus asio

Length, about eight inches. Our smallest owl with ear tufts. There are two distinct phases of plumage, one grayish and the other bright rufous.

Range

Resident throughout the United States, Southern Canada, and Northern Mexico.

Habits and Economic Status

The little screech owl inhabits orchards, groves and thickets, and hunts for its prey in such places as well as along hedgerows and in the open. During warm spells in winter it forages quite extensively and stores up in some hollow tree considerable quantities of food for use during inclement weather. Such larders frequently contain enough mice or other prey to bridge over a

period of a week or more. With the exception of the burrowing owl it is probably the most insectivorous of the nocturnal birds of prey. It feeds also upon small mammals, birds, reptiles, batrachians, fish, spiders, crawfish, scorpions and earthworms. Grasshoppers, ground-dwelling beetles, crickets, and caterpillars are its favorites among insects, as are field mice among mammals and sparrows among birds. Out of 324 stomachs examined, 169 were found to contain insects; 142, small mammals; 56, birds; and 15, crawfish. The screech owl should be encouraged to stay near barns and out-houses, as it will keep in check house mice and wood mice, which frequent such places.

Barn Owl

Aluco pratincola

Length, about 17 inches. Facial disk not circular as in our other owls; plumage above, pale yellow; beneath, varying from silky white to pale bright tawny.

Range

Resident in Mexico, in the Southern United States, and north to New York, Ohio, Nebraska and California.

Habits and Economic Status

The barn owl, often called monkey-faced owl, is one of the most beneficial of the birds of prey, since it feeds almost exclusively on small mammals that injure farm produce, nursery, and orchard stock. It hunts principally in the open and consequently secures such mammals as pocket gophers, field mice, common rats, house mice, harvest mice, kangaroo rats and cotton rats. It occasionally captures a few birds and insects. At least a half bushel of the remains of pocket gophers have been found in the nesting cavity of a pair of these birds. Remembering that a gopher has been known in a short time to girdle seven apricot trees worth \$100 it is hard to overestimate the value of the service of a pair of barn owls. 1,247 pellets of the barn owl collected from Smithsonian towers contained 3,100 skulls, of which 3,004, or 97 per cent, were of mammals; 92, or three per cent, of birds; and four were of frogs.

The bulk consisted of 1,987 field mice, 656 house mice, and 210 common rats. The birds eaten were mainly sparrows and blackbirds. This valuable owl should be rigidly protected throughout its entire range.

Sparrow Hawk

Falco sparverius

Length, about 10 inches. This is one of the best known and handsomest, as well as the smallest, of North American hawks.

Range

Breeds throughout the United States, Canada and Northern Mexico; winters in the United States and south to Guatemala.

Habits and Economic Status

The sparrow hawk, which is a true falcon, lives in the more open country and builds its nest in hollow trees. It is abundant in many parts of the West, where telegraph poles afford it convenient perching and feeding places. Its food consists of insects, small mammals, birds, spiders and reptiles. Grasshoppers, crickets, and terrestrial beetles and caterpillars make up considerably more than half its subsistence, while field mice, house mice, and shrews cover fully 25 per cent of its annual supply. The balance of the food includes birds, reptiles, and spiders. Contrary to the usual habits of the species, some individuals during the breeding season capture nestling birds for food for their young and create considerable havoc among the songsters of the neighborhood. In agricultural districts when new ground is broken by the plow, they sometimes become very tame, even alighting for an instant under the horses in their endeavor to seize a worm or insect. Out of 410 stomachs examined, 314 were found to contain insects; 129, small mammals; and 70, small birds. This little falcon renders good service in destroying noxious insects and rodents and should be encouraged and protected.

Red-Tailed Hawk

Buteo borealis

Length, about two feet. One of our largest hawks; adults with tail reddish brown.

Range

Breeds in the United States, Mexico, Costa Rica, Canada, and Alaska; winters generally in the United States and south to Guatemala.

Habits and Economic Status

The red-tailed hawk, or "hen hawk," as it is commonly called, is one of the best known of all our birds of prey, and is a widely distributed species of great economic importance. Its habit of sitting on some prominent limb or pole in the open, or flying with measured wing beat over prairies and sparsely wooded areas on the lookout for its favorite prey, causes it to be noticed by the most indifferent observer. Although not as omnivorous as the red-shouldered hawk, it feeds on a variety of food, as small mammals, snakes, frogs, insects, birds, crawfish, centipedes, and even carrion. In regions where rattlesnakes abound it destroys considerable numbers of the reptiles. Although it feeds to a certain extent on poultry and birds, it is nevertheless entitled to general protection on account of the insistent warfare it wages against field mice and other small rodents and insects that are so destructive to young orchards, nursery stock, and farm produce. Out of 530 stomachs examined, 457, or 85 per cent, contained the remains of mammal pests such as field mice, pine mice, rabbits, several species of ground squirrels, pocket gophers, and cotton rats, and only 62 contained the remains of poultry or game birds.

Cooper's Hawk

Accipiter cooperi

Length, about 15 inches. Medium sized, with long tail and short wings, and without the white patch on rump which is characteristic of the marsh hawk.

Range

Breeds throughout most of the United States and Southern Canada; winters from the United States to Costa Rica.

Habits and Economic Status

The Cooper's hawk, or "blue darter," as it is familiarly known throughout the South, is preeminently a poultry and bird-eating species, and its destructiveness in

this direction is surpassed only by that of its larger congener, the goshawk, which occasionally in autumn and winter enters the United States from the North in great numbers. The almost universal prejudice against birds of prey is largely due to the activities of these two birds, assisted by a third, the sharp-shinned hawk, which in habits and appearance might well pass for a small Cooper's hawk. These birds usually approach under cover and drop upon unsuspecting victims, making great inroads upon poultry yards and game coverts favorably situated for this style of hunting. Out of 123 stomachs examined, 38 contained the remains of poultry and game birds, 66 the remains of other birds, and 12 the remains of mammals. Twenty-eight species of wild birds were identified in the above-mentioned material. This destructive hawk, together with its two near relatives, should be destroyed by every possible means.

Mourning Dove

Zenaidura macroura

Length, 12 inches. The dark spot on the side of the neck distinguishes this bird from all other native doves and pigeons except the white-winged dove. The latter has the upper third of wing white.

Range

Breeds throughout the United States and in Mexico, Guatemala and Southern Canada; winters from the Central United States to Panama.

Habits and Economic Status

The food of the mourning dove is practically all vegetable matter (over 99 per cent), principally seeds of plants, including grain. Wheat, oats, rye, corn, barley, and buckwheat were found in 150 out of 237 stomachs, and constituted 32 per cent of the food. Three-fourths of this was waste grain picked up after harvest. The principal and almost constant diet is weed seeds, which are eaten throughout the year and constitute 64 per cent of the entire food. In one stomach were found 7,500 seeds of yellow wood sorrel, in another 6,400 seeds of barn grass or foxtail, and in a third 2,600 seeds of

slender paspalum, 4,820 of orange hawk weed, 950 of hoary vervain, 120 of Carolina cranesbill, 50 of yellow wood sorrel, 620 of panic grass, and 40 of various other weeds. None of these are useful, and most of them are troublesome weeds. The dove does not eat insects or other animal food. It should be protected in every possible way.

Ruffed Grouse

Bonasa umbellus

Length, 17 inches. The broad black band near tip of tail distinguishes this from other grouse.

Range

Resident in the northern two-thirds of the United States and in the forested parts of Canada.

Habits and Economic Status

The ruffed grouse, the famed drummer and finest game bird of the northern woods, is usually wild and wary and under reasonable protection well withstands the attacks of hunters. Moreover, when reduced in numbers, it responds to protection in a gratifying manner and has proved to be well adapted to propagation under artificial conditions. Wild fruits, mast, and browse make up the bulk of the vegetable food of this species. It is very fond of hazelnuts, beechnuts, chestnuts and acorns, and it eats practically all kinds of wild berries and other fruits. Nearly 60 kinds of fruits have been identified from the stomach contents examined. Various weed seeds also are consumed. Slightly more than 10 per cent of the food consists of insects, about half being beetles. The most important pests devoured are the potato beetle, clover-root weevil, the pale-striped flea beetle, grapevine leaf beetle, May beetles, grasshoppers, cotton worms, army worms, cutworms, the red-humped apple worm, and sawfly larvae. While the economic record of the ruffed grouse is fairly commendable, it does not call for more stringent protection than is necessary to maintain the species in reasonable numbers.

Bobwhite

Colinus virginianus

Length, 10 inches. Known everywhere by the clear whistle that suggests its name.

Range

Resident in the United States east of the plains; introduced in many places in the West.

Habits and Economic Status

The bobwhite is loved by every dweller in the country and is better known to more hunters in the United States than any other game bird. It is no less appreciated on the table than in the field, and in many states has unquestionably been hunted too closely. Fortunately it seems to be practicable to propagate the bird in captivity, and much is to be hoped for in this direction. Half the food of this quail consists of weed seeds, almost a fourth of grain, and about a tenth of wild fruits. Although thus eating grain, the bird gets most of it from stubble. Fifteen per cent of the bobwhite's food is composed of insects, including several of the most serious pests of agriculture. It feeds freely upon Colorado potato beetles and chinch bugs; it devours also cucumber beetles, wireworms, billbugs, clover-leaf weevils, cotton-boll weevils, army worms, bollworms, cutworms, and Rocky Mountain locusts. Take it all in all, bobwhite is very useful to the farmer, and while it may not be necessary to remove it from the list of game birds every farmer should see that his own farm is not depleted by eager sportsmen.

Killdeer

Oryechus vociferus

Length, 10 inches. Distinguished by its piercing and oft-repeated cry—*killdee*.

Range

Breeds throughout the United States and most of Canada; winters from Central United States to South America.

Habits and Economic Status

The killdeer is one of the best known of the shorebird family. It often visits the farmyard and commonly nests in pastures or cornfields. It is rather sus-

precious, however, and on being approached takes flight with loud cries. It is noisy and restless, but fortunately most of its activities result in benefit to man. The food is of the same general nature as that of the upland plover, but is more varied. The killdeer feeds upon beetles, grasshoppers, caterpillars, ants, bugs, caddis flies, dragon flies, centipedes, spiders, ticks, oyster worms, earthworms, snails, crabs and other crustacea. Among the beetles consumed are such pests as the alfalfa weevil, cotton-boll weevil, clover-root weevil, clover-leaf weevil, pine weevil, billbugs, white grubs, wireworms, and leaf beetles. The bird also devours cotton worms, cotton cutworms, horseflies, mosquitoes, cattle ticks, and crawfish. One stomach contained hundreds of larvae of the saltmarsh mosquito, one of the most troublesome species. The killdeer preys extensively upon insects that are annoying to man and injurious to his stock and crops, and this should be enough to remove it from the list of game birds and insure its protection.

Upland Plover

Bartramia longicauda

Length, 12 inches. The only plainly colored shorebird which occurs east of the plains and inhabits exclusively dry fields and hillsides.

Range

Breeds from Oregon, Utah, Oklahoma, Indiana and Virginia, north to Alaska; winters in South America.

Habits and Economic Status

This, the most terrestrial of our waders, is shy and wary, but it has the one weakness of not fearing men on horseback or in a vehicle. One of these methods of approach, therefore, is nearly always used by the sportsman, and, since the bird is highly prized as a table delicacy, it has been hunted to the verge of extermination. As the upland plover is strictly beneficial, it should no longer be classed as a game bird and allowed to be shot. Ninety-seven per cent of the food of this species consists of animal forms, chiefly of injurious and neutral species. The vegetable food is mainly weed seeds. Al-

most half of the total subsistence is made up of grasshoppers, crickets and weevils. Among the weevils eaten are the cotton-boll weevil, greater and lesser clover-leaf weevils, cowpea weevils, and billbugs. This bird devours also leaf beetles wire worms, white grubs, army worms, cotton worms, cotton cutworms, sawfly larvae, horseflies, and cattle ticks. In brief, it injures no crop, but consumes a host of the worst enemies of agriculture.

Black Tern

Hydrochelidon nigra surinamensis

Length, 10 inches. In autumn occurs as a migrant on the east coast of the United States, and then is in white and gray plumage. During the breeding season it is confined to the interior, is chiefly black, and is the only dark tern occurring inland.

Range

Breeds from California, Colorado, Missouri, and Ohio, north to Central Canada; winters from Mexico to South America; migrant in the Eastern United States.

Habits and Economic Status

This tern, unlike most of its relatives, passes much of its life on fresh-water lakes and marshes of the interior. Its nests are placed among the tules and weeds, on floating vegetation, or on muskrat houses. It lays from two to four eggs. Its food is more varied than that of any other tern. So far as known it preys upon no food fishes, but feeds extensively upon such enemies of fish as dragon fly nymphs, fish-eating beetles, and crawfishes. Unlike most of its family, it devours a great variety of insects, many of which it catches as it flies. Dragon flies, May flies, grasshoppers, predaceous diving beetles, scarabaeid beetles, leaf beetles, gnats, and other flies are the principal kinds preyed upon. Fishes of little economic value, chiefly minnows and mummichogs, were found to compose only a little more than 19 per cent of the contents of 145 stomachs. The great consumption of insects by the black tern places it among the beneficial species worthy of protection.

Franklin's Gull*Larus franklini*

Length, 15 inches. During its residence in the United States Franklin's gull is practically confined to the interior and is the only inland gull with black head and red bill.

Range

Breeds in the Dakotas, Iowa, Minnesota and the neighboring parts of Southern Canada; winters from the Gulf coast to South America.

Habits and Economic Status

Nearly all of our gulls are coast-loving species and spend comparatively little of their time in fresh water, but Franklin's is a true inland gull. Extensive marshes bordering shallow lakes are its chosen breeding grounds, and as many such areas are being reclaimed for agricultural purposes it behooves the tillers of the soil to protect this valuable species. When undisturbed this gull becomes quite fearless and follows the plowman to gather the grubs and worms from the newly turned furrows. It lives almost exclusively upon insects, of which it consumes great quantities. Its hearty appetite is manifest from the contents of a few stomachs: A, 327 nymphs of dragon flies; B, 340 grasshoppers, 52 bugs, three beetles, two wasps, and one spider; C, 82 beetles, 87 bugs, 984 ants, one cricket, one grasshopper, and two spiders. About four-fifths of the total food is grasshoppers, a strong point in favor of this bird. Other injurious creatures eaten are billbugs, squash bugs, leaf hoppers, click beetles (adults of wire worms), May beetles (adults of white grubs), and weevils. Franklin's gull is probably the most beneficial bird of its group.

HENRY W. HENSHAW,
Washington, D. C.

The above descriptions are taken from U. S. Dept. Agri. Farm. Bul. 513. Other references to Government literature are:

Farm. Buls. 54, 497; Biological Survey Buls 3, 9, 13, 15, 21, 23, 24, 30, 32, 34, 37, 39, 44. Dept. Agri. Yr. Book 1895.

Blackberry

Anyone who is familiar with farming conditions in the Eastern states knows by experience that the blackberry is one

of the most common and one of the most tenacious of American native fruits. In Tennessee, Virginia, West Virginia, Kentucky, Pennsylvania, and other states, they spring up in abandoned fields and are difficult to eradicate.

The leading representative of this group is *Rubus nigrobaccus*.

All varieties change rapidly under cultivation and are, therefore, being rapidly improved. The blackberry thrives best usually on a northern slope, on heavy loamy soil, retentive of moisture. If the soil is rich in nitrogenous foods it tends to heavy wood growth, and but little fruit; if, however, there is little humus in the soil, it tends to fruit and less wood growth. In this particular it follows the law of most other fruits, for this is true of peaches, pears, apples and plums, as well as of berries.

Propagation

Propagation is almost always by means of sprouts or suckers that spring up from the roots. These grow in great abundance and when not desired for propagation are a hindrance, causing considerable work to keep them down. They also take strength from the parent stock and prevent the best development of the fruit. If the finest fruit is desired these suckers must be kept down; if suckers are desired for the market, they injure the fruit just the same; but the grower will decide whether his profits come mostly from fruits or plants and will give the preference to that which seems most valuable.

Medicinal Qualities

Blackberries are esteemed for their tendency to counteract bowel trouble, chronic diarrhoea, and were formerly used extensively for this purpose.

Planting

The setting of blackberries is not a difficult task. The first thing to do is to determine whether they are to be set in rows, or in squares, which some call the check system. This question would probably be determined by the contour of the land on which the orchard was to be located. If the land is rough, it may be found impracticable to use the check sys-

tem in cultivating; but if it is smooth or level so that it can be cultivated both ways, the check system is, to our mind, preferable. The row system consists of setting the plants in rows, from five to ten feet apart, and the plants from three to five feet apart in the row. The check system is one in which the plants are set five to seven feet apart each way. The distances apart should be determined largely by the nature of the plants. Some varieties tend to grow large and tall while others grow short and stocky. It is practicable to put twice as many of the small varieties on a given area, as of the largest growers. Distances apart will also be determined in part by the character of the soil. A very rich soil will support more plants than a poor soil. When the nature and habits of the varieties are determined and when the character of the soil is considered, then the question of distances will be determined, and the method of planting will logically follow. Our preference is toward the check, or square system, if the land is suited to that style of planting. Our reasons are that, by that method, more fruit and better fruit can be produced with a given amount of labor than by any other. By this method the land can be cultivated both ways and the work of hoeing largely eliminated. By this method also the sun shines more evenly upon all parts of the plant and tends toward a fuller and more uniform development of the fruit.

If the row method is adopted, run a deep furrow where the plants are to be placed. If the square or check method is adopted, mark off the land both ways and run a deep furrow one way. Then prune the broken roots and cut back the top to about four to eight inches in height; they are then ready for setting. In setting the plants, care should be used to prevent the drying of the roots. Perhaps the best method is to place the roots in water, having one man to drop them and two to set them. The three working together make a team. This will set the plants with less labor than a smaller number working a longer period of time. Some recommend that the "dropper" carry the

plants in a bucket of water. This will do if only a small number are to be set, but if a large field is to be planted it is easier to have a broad water-tight box on a sled, in which the plants are placed, and drawn by a horse. For the number of plants per acre, see our "Table of Distances," page 155. Set the plants from a half to one inch deeper than they grow in the nursery.

Cultivation

The cultivation blackberries should receive depends mostly on the conditions under which they grow. If they grow where there is a lack of moisture, it will be necessary to keep the ground thoroughly pulverized, so as to form a dust mulch and conserve the moisture. Sometimes it will be necessary also to mulch with straw, barnyard manure or leaves.

In portions of the country where irrigation is practiced and where there is plenty of moisture, the land should be cultivated after each and every irrigation, which would probably be about every 20 to 30 days. In any event, the weeds and the suckers must be kept down and the land kept well pulverized, so that by the process of aeration, the roots are properly supplied with food.

Training and Staking

Upon this subject we quote here from W. S. Thornber, formerly professor of horticulture at Pullman, Wash

"The 'Upright Growers' where planted in hills can best be staked by a single strong stake from four to six feet in height and the canes loosely but securely fastened to the stake. Some growers prefer to set two stakes about 15 inches apart at each hill of blackberries with the idea of training the fruiting canes on one and the growing canes on the other. Where the 'Upright Growers' are planted in a continuous row they may be trained to and supported by a two-wire trellis consisting of a single row of posts four to five feet high with a single No. 10 wire stapled to the top and another from 18 to 24 inches from the top. The more common method however, is to set a single line of posts four or five feet high in the row, nail an 18-inch cross-arm three feet

from the ground and another at the top of the posts, and to the ends of these arms staple heavy wires, thus forming firm lateral supports for the canes

"The four-wire trellis with the addition of notched cross pieces to lay on the lower wires makes an excellent support for the 'Viny Growers,' the purpose being to suspend the growing canes by means of small cloth strings under the upper wires for the first year and at pruning time lower them to rest on the notched pieces on the lower wires for their fruiting period. This makes an easy system to work and keeps the growing and fruiting canes separate, thereby simplifying the picking"

Pruning

The pruning of the blackberry is a simple matter, if only a few rules are observed.

The first is to keep the tops cut back, or pinched back to the proper height, during the growing season while they are young and tender. This allows the plant to grow stocky, and to mature better fruit than if the strength of the plant had been allowed to produce more wood growth. The second is to remove the old canes in winter or spring.

Some varieties of plants will grow on good soils from 10 to 20 feet in height. This makes the picking of the fruit impossible. These should be cut back during the growing season. Others tend to grow shaggy and bushy. In such a case it might be found advisable to train them to grow taller.

In very cold climates the pruning should be done in the autumn, the plants laid down and given a covering of straw or earth to prevent freezing, but where this is done, berries are grown mostly for home use, as it does not pay to grow fruits for the general markets in competition with those sections where the conditions are more favorable and the fruit can be produced with less labor.

Picking and Marketing

For long shipments the berries should be picked as soon as colored. However, it must be borne in mind that blackber-

ries color before they are ripe enough to have a pleasant taste. It is regrettable that so many varieties of fruits, in order to reach the markets in good condition, must be picked before they are ripe, but in many cases this is true. However, by the use of refrigerator cars, pre-cooling methods and rapid transit, the fruit may be left to ripen, unless intended for long distance shipment.

After picking, the berries should not be allowed to stand in the sun because, if thus exposed, they develop a bitter taste.

Perhaps the most convenient package for blackberries, strawberries or any kind of small fruit, is the strawberry box. It is a size to which the public is accustomed and which manufacturers are prepared for making without readjusting their machinery.

Drying Blackberries

The drying of blackberries has been strongly recommended by a great many persons. The experience of some persons leads to the conclusion that it pays, while others are of a contrary opinion. Card, in his "Bush Fruits," gives it as his opinion that it does not pay. His reasons are, that the blackberry by evaporation loses much of its flavor. Then, too, it comes into competition with the fresh berries, grown in the South and shipped into Northern markets. These berries from the South are not considered equal in flavor to the berries grown in the North, yet they are so far superior to the Northern berry dried that they practically destroy the demand for the dried product. In our experience, the competition with the canned product is formidable, and we should not, therefore, attempt to dry blackberries for the general market unless under conditions where canning was impracticable. However, there are markets for dried fruits. We may take as an illustration, Alaska, where the costs of shipment are high, and where all fruits are scarce.

The profits in berries are all the way from \$100 per acre to \$500 net, depending on the man, the varieties, and the circumstances under which grown and marketed.



Mercereau



Early Harvest



Texas



Minnewaski



Snyder



Stone's Hardy



Kittatinny



Parker



Ohmer

Blackberries

- 1—Mercereau: Fruit large, rather acid, of good quality, quite soft; season long, a good berry for home use. 2.—Stone's Hardy: Fruit medium in size, quite prolific and of fair quality. 3—Texas: Fruit of good size, very prolific, rather soft when fully ripe; earlier than the Snyder but of poorer quality. 4—Minnewaski: Fruit medium in size, and of fair quality; not as good as Snyder. 5—Snyder: The most popular blackberry; fruit medium in size, very firm, prolific and of excellent quality; very subject to disease. 6—Early Harvest: Fruit early, small, acid, not profitable here. 7—Kittatinny: Fruit rather large, quite firm, of fair quality, not as prolific as the Snyder, not as good a berry. 8—Parker: A berry of good size, quality, and firmness, grown locally in Whatcom county where it is said to equal or excel the Snyder. 9—Ohmer: A berry of medium size, fair quality and not very prolific. 10—Mammoth (not on the photo): Fruit large, acid, good quality. Plant has a trailing habit and very thorny. Not prolific enough to be grown with profit.

Photo and Descriptions by J. H. Stahl, Western Washington Experiment Station

Varieties Recommended for Planting Washington

W. S. Thoinbei, formerly Horticulturist Washington State College, recommends the following for that state

Early Mammoth—An early fine large, rich flavored berry. Rather tender for general planting but valuable where quality is desired.

Evergreen—One of our hardiest, most productive and best all-round late blackberries. Value for commercial as well as home growing purposes.

Himalaya Giant—A rather slight known, productive, rank-growing, viny sort. Valuable for commercial planting west of the Cascade mountains, but too tender for general planting.

Kittatinny—A very commonly planted sort, and while rather tender and subject to rust, yet produces very satisfactory crops.

Snyder—One of our best and most popular early sorts. Valuable for commercial as well as home purposes.

Stones' Hardy—An old, well-known, late variety. Valuable only where the more productive sorts will not stand the winters.

Loganberry—One of our newer fruits which is rapidly becoming popular on account of its productiveness, large fruit and fine quality. Grows well in all parts of the state but requires light winter protection in eastern Washington.

Phenomenal Berry—A fruit closely resembling the loganberry and profitably grown under the same conditions.

Lucretia Dewberry—A valuable but not well known recent addition to the blackberry family. While it is hardy, its trailing habit makes it possible to successfully grow this plant, by giving it winter protection, where the ordinary blackberry winter kills. Its early fruiting habit, productiveness and ability to thrive on many soils makes it popular as an orchard filler in many parts of the state.

GRANVILLE LOWTHER

Cost of Growing Blackberries in the Puyallup Valley

It is estimated in the Puyallup valley that it costs the grower 25 cents per crate

of 24 crates for picking. The crate costs 15 cents; hauling to the depot and other incidentals, 7½ cents; cultivation and taking care of the canes, 7½ cents. Add to this the Association charge, which will average about 5 cents per crate, and there is a total of 60 cents. President W. H. Paulhamus states that the P. & S. Association can sell the Evergreen blackberries at an average net return to the grower of 85 cents, and he still has 25 cents per crate above the cost of production. Eight hundred crates to the acre would mean \$200 per acre profit. Six hundred crates per acre means \$150 per acre profit, providing the market is ample.—*Northwest Horticulturist*

Blackberries Recommended

Blackberries recommended for cultivation, in the various districts, by the American Pomological Society.

For map of districts see recommendations under apple, page 192.

District No. 1

RECOMMENDED—*Dessert, kitchen and market*: Eldorado. *Dessert and market*: Agawam; Minnewaska; Snyder. *Dessert and kitchen*: Lucretia (dewberry). *Market*: Briton, *Ancient*; Erie. *Dessert*: Stone; Taylor; Triumph, *Western*; Wachusett.

District No. 2

HIGHLY RECOMMENDED—*Dessert and market*: Agawam; Early Harvest; Snyder. *Dessert and kitchen*: Lucretia (dewberry). *Market*: Briton, *Ancient*; Erie; Wilson. *Dessert*: Taylor.

RECOMMENDED—*Dessert, kitchen and market*: Eldorado. *Dessert and market*: Brunton; Minnewaska. *Market*: Lawton. *Dessert*: Kittatinny; Stone; Triumph, *Western*; Wachusett.

RECOMMENDED FOR TRIAL—*Dessert and market*: Allen.

District No. 3

HIGHLY RECOMMENDED—*Dessert and market*: Early Harvest; Minnewaska. *Dessert and kitchen*: Lucretia (dewberry). *Market*: Erie.

RECOMMENDED—*Dessert, kitchen and market*: Eldorado. *Dessert and market*: Mayes (*Austin*) [dewberry]; Snyder.

Market: Briton, *Ancient*; Wilson. *Dessert:* Kittatinny; Taylor.

District No. 4

HIGHLY RECOMMENDED—*Dessert and market:* Mayes (*Austin*) [dewberry]; Snyder. *Dessert and kitchen:* Lucretia [dewberry]; *Market:* Lawton. *Dessert:* Kittatinny.

RECOMMENDED—*Dessert and market:* Early Harvest; Minnewaska. *Market:* Briton, *Ancient*; Erie. *Dessert:* Taylor; Wachusett.

RECOMMENDED FOR TRIAL — *Dessert:* Triumph, Western.

District No. 5

HIGHLY RECOMMENDED—*Dessert, kitchen and market:* Dallas. *Dessert and market:* Early Harvest; Snyder. *Dessert and kitchen:* Lucretia [dewberry]. *Market:* Erie. *Dessert:* Kittatinny; Stone.

RECOMMENDED—*Dessert and market:* Mayes (*Austin*) [dewberry]; Minnewaska. *Market:* Lawton, Wilson.

District No. 6

HIGHLY RECOMMENDED—*Dessert and market:* Mayes (*Austin*) [dewberry]. *Dessert and kitchen:* Lucretia [dewberry].

RECOMMENDED—*Dessert, kitchen and market:* Dallas. *Dessert and market:* Brunton. *Dessert:* Kittatinny. *Market:* Briton, *Ancient*.

District No. 7

HIGHLY RECOMMENDED—*Dessert, kitchen and market:* Dallas. *Dessert and market:* Brunton; Early Harvest; Mayes (*Austin*) [dewberry]. *Dessert and kitchen:* Lucretia [dewberry]. *Dessert:* Kittatinny.

RECOMMENDED — *Dessert, kitchen and market:* Eldorado. *Kitchen and market:* Robison. *Dessert and market:* Minnewaska. *Market:* Briton, *Ancient*. *Dessert:* Taylor.

District No. 8

HIGHLY RECOMMENDED—*Dessert and market:* Early Harvest; Mayes (*Austin*) [dewberry]; Snyder. *Dessert and kitchen:* Lucretia [dewberry]. *Market:* Briton, *Ancient*; Erie. *Dessert:* Taylor.

RECOMMENDED—*Market* Lawton. *Dessert:* Wachusett.

RECOMMENDED FOR TRIAL—*Dessert, kitchen and market* Eldorado.

District No. 9

HIGHLY RECOMMENDED—*Market:* Briton, *Ancient*.

RECOMMENDED—*Dessert and kitchen.* Lucretia [dewberry].

Districts No. 10 and No. 11

HIGHLY RECOMMENDED—*Market:* Briton, *Ancient*; Wilson; Robison.

RECOMMENDED—*Dessert and market:* Agawam; Early Harvest; Minnewaska; Snyder. *Dessert and kitchen:* Lucretia [dewberry]; Dallas. *Market:* Erie; Lawton. *Dessert:* Kittatinny; Taylor.

District No. 12

HIGHLY RECOMMENDED — *Dessert and market:* Snyder. *Dessert and kitchen:* Lucretia (dewberry). *Market:* Briton, (*Ancient*), Wilson. *Dessert:* Taylor.

RECOMMENDED — *Dessert and market:* Early Harvest. *Market:* Erie; Lawton. *Dessert:* Kittatinny; Stone.

District No. 13

HIGHLY RECOMMENDED — *Dessert and kitchen:* Lucretia (dewberry).

RECOMMENDED — *Dessert and market:* Snyder. *Market:* Wilson.

District No. 14

HIGHLY RECOMMENDED — *Dessert and kitchen:* Lucretia (dewberry), *Market:* Erie; Lawton. *Dessert:* Kittatinny.

RECOMMENDED — *Dessert and market:* Snyder. *Market:* Briton, *Ancient*; Wilson.

RECOMMENDED FOR TRIAL—*Dessert, kitchen and market:* Eldorado. *Dessert and market:* Early Harvest.

District No. 15

HIGHLY RECOMMENDED — *Market:* Lawton. *Dessert:* Kittatinny.

RECOMMENDED — *Dessert and market:* Snyder. *Dessert:* Stone.

District No. 16

RECOMMENDED—*Market:* Lawton. *Dessert:* Kittatinny; Crandall.

District No. 17

RECOMMENDED — *Dessert and market*:
Early Harvest *Market* Lawton; Wil-
son *Dessert* Kittatinny; Crandall.

District No. 18

HIGHLY RECOMMENDED—Crandall.
RECOMMENDED — *Dessert and kitchen*:
Lucretia (dewberry). *Market*: Lawton.
Dessert: Kittatinny.

BLACKBERRY DISEASES

ANTHRACNOSE. See *Raspberry*.
BRAMBLE RUST. See *Rust*, this section.

Crown Gall

Bacterium tumefaciens

Produces large swellings just below the ground. Destroy all affected plants and use care in planting clean stock.

For extended article on crown gall, see under *Apple*.

Fruit Rot

Botrytis

The ripe fruit decays on the bushes and is covered with a gray, dusty mould. More abundant in moist weather.

No treatment feasible. Affected fruits should be discarded, as the rot will spread to unaffected fruit after picking.

Leaf Spot

Septoria rubi

Produces small dead spots on the leaves.

Spray with Bordeaux mixture about four times at intervals of about ten days, the first application when the buds are beginning to unfold.

R. E. SMITH,
Berkeley, Cal.

MUSHROOM ROOT ROT. See *Raspberry*.
ORANGE RUST. See *Rust*, this section.

Red or Bramble Rust

Caecoma nitens Schw.

Wild and cultivated blackberries suffer from this disease as well as raspberries.

Similar in appearance to the orange rust and requires the same treatment.

Rust, Orange Rust

Gymnoconia interstitialis

Produces bright orange masses of spores all over the under side of the leaves. The fungus spreads all through the plant so that it is not easily controlled.

Cut affected plants to the ground and

burn. Spray new growth with Bordeaux mixture

R. E. SMITH,
Berkeley, Cal.

BLACKBERRY PESTS

AMERICAN RASPBERRY BEETLE. See *Raspberry*

APPLE LEAF HOPPER. See under *Apple*.

BLACK CHERRY APHIS. See *Aphids*.

BLACKBERRY APHIS. See *Aphids*.

The Blackberry Crown Borer

Bembecia marginata

This borer does considerable damage. After growth starts in the spring, some canes may be found to be dead. In some cases, an examination will reveal at the base of such canes, a 16-legged borer, resembling the peach borer. Many of such canes will be found to have been partially girdled just at the base during the preceding fall, and the pith of the same bored out by the caterpillar. The parent moth is a clear winged insect, quite resembling a brightly colored wasp. The body is black, banded and marked with yellow. The eggs are laid in the fall. The most reliable remedy is to cut out all infested canes as soon as they are discovered and burn, taking care not to allow any of the borers to escape from the canes before they are burned.

H. A. GOSSARD,
Wooster, Ohio.

BLACK PEACH APHIS. See *Aphids*.

Bramble, Flea Louse

Trioza tripunctata Fitch.

A tiny insect which has been found to be troublesome in some of the Eastern states. A curling of the leaves follows the attack. The nymphs are covered with jointed waxy threads which break off readily and give the leaf a powdery appearance when the insects are numerous.

As soon as the winged forms appear spray with kerosene emulsion.

Not likely to become serious.

BUD MOTH. See under *Apple*.

Cane Borer of Blackberry and Raspberry

Oberea bimaculata

The adult beetle girdles the tip of the cane with a row of punctures in laying her eggs, so that the tips droop and wither. The grub is a blind worm without feet

and burrows downward in the pith. It has a brown head and by fall is about an inch long.

Affected canes should be cut out and burned, if in midsummer, below the girdled tip; if in the autumn, at the ground.

FLEA LOUSE. See *Bramble-Flea Louse*. this section.

Gouty-Gall Beetle

Agrilus ruficollis

The young borers of this species commence work in July and August. The slender, round-headed larvae enter the canes at the bases of the leaf stalks, and from such points work around the canes in long, spiral tunnels through the sapwood. Later in the season, the canes swell over the eaten areas, forming enlargements or galls which are very conspicuous when the leaves fall. The only remedy is to prune out and burn the galls containing the larvae, and since galled canes will never prove of value, they may be cut out whenever discovered. Cut wild canes along roadsides and in nearby woodlands and burn in the fall of the year after the larvae have entered them.

H. A. GOSSARD,
Wooster, Ohio.

LEAF HOPPER. See under *Apple*.

OYSTER SHELL SCALE. See under *Apple*.

PALE BROWN BYTHURUS. See *Raspberry*.

Pithy Gall and Seed-like Gall

A large gall, two or three inches long, sometimes found on blackberry canes, is divided by four or five furrows into as many longitudinal lobes. Within the gall can be found small, footless, whitish grubs, which, in the spring of the year, transform to small, four-winged flies. The insect is not very important, but the galls should be pruned out and burned. This formation is known as the pithy gall of the blackberry, and the insect causing it is *Diastrophus nebulosus*.

A closely related gall of the blackberry is known as the seed-like gall, and is caused by *Diastrophus cuscuteiformis*, much resembling the preceding species. This is a composite gall, consisting of a ring of single seed-like galls, the belt

being an inch or an inch and one-half in depth. Cut out and burn

H. A. GOSSARD,
Wooster, Ohio

RASPBERRY BEEILL. See under *Raspberry*.

RASPBERRY HORN TAIL. See *Raspberry*

RED SPIDER. See under *Apple*

The Rose Scale

Aulacaspis rosae Bouche

General Appearance

The female scales are nearly circular with very irregular edges and white to gray in color with reddish body. The diameter varies from one-sixteenth to one-eighth of an inch. The male scales are long and narrow, very minute, with three longitudinal creases, or carinae, and the bodies reddish white.

Life History

All stages of this scale occur practically throughout the entire year, including the eggs, and its spread is very rapid. The females cluster in great numbers on the canes of berries and roses, especially around the crown of the roots. It is especially abundant during the spring and summer months. It attacks wild and cultivated plants.

Food Plants

Blackberries, raspberries and roses. Abundant on wild blackberries in the Sacramento valley.

Control

As the eggs are present at practically all seasons and are hard to kill, by either spraying or fumigation, this is a somewhat difficult scale to control. The worst infected canes should be cut out and burned and the remaining sprayed successively with kerosene, distillate or carbolic acid emulsion, or with lime-sulphur when the plants are dormant in the winter.

E. O. ESSIG

SAN JOSE SCALE. See under *Apple*.

Saw Fly

Pamphilius dentatus

A small green worm the larva of one of the sawflies, feeds on the under side of the leaves.

Spray with Paris green, arsenate of lead or, if the fruit has formed, with hellebore.

For formulae see *Sprays*

SCURRY SCALE See under *Apple*

SLED-LIKE GALL. See *Pithy Gall*, this section.

Snowy Tree Cricket

Oecanthus niveus DeGeer

General Appearance

The adult insects are slightly more than half an inch long and light yellow or greenish in color. The antennæ are very long and hair-like. There is one black dot on the face beneath each antenna. The females appear narrow, because the wings are folded along the sides and over the backs, while in the males they are spread out flatly on the back. The black-tipped ovipositor also helps to distinguish the female. The eggs are about one-eighth of an inch long, slender, slightly curved and white. They are inserted in the stems of the host.

Life History

The eggs are placed singly in the canes or twigs in the autumn and remain dormant during the winter. The first warm spring days cause them to hatch and the young, wingless, green crickets begin feeding upon plant lice or other soft-bodied insects. Throughout its entire life, from the time it leaves the egg until egg-laying commences in the fall the insect is working for the benefit of the farmer. By autumn all forms are mature and egg-laying begins, the adults disappearing soon afterwards.

Food and Host Plants

The damage done by the snowy tree-cricket is due almost entirely to its method of puncturing the small stems and canes in egg-laying. It often happens that so many eggs are placed in the canes as to cause considerable loss. Raspberries and blackberries receive the most injury, though young deciduous fruit nursery stock is also often severely injured.

The feeding habits of this species places it among the beneficial insects and partially offset the damage done in de-

positing the eggs. The young and old alike feed upon soft-bodied insects, principally plant lice, and due to their ravenous appetites they are able to consume great numbers of other injurious pests.

Control

The method of eliminating subsequent broods and attacks consists in cutting out all canes showing the characteristic signs of having been punctured for egg-laying. It has been said by many reliable authorities that the good done by the snowy tree cricket in destroying injurious plant lice and other soft-bodied insects more than recompenses the farmer for the harm done and that only in rare cases should the eggs be destroyed, even after the injured canes or branches have been removed.

E. O. ESSIG,
Sacramento, Cal.

TARNISHED PLANT BUG. See *Strawberry*.

TREE CRICKET. See *Snowy Tree Cricket*, this section.

Blooming Period of Tree Fruits

The value of bloom charts and their bearing on the question of mixed planting is appreciated by a large number of our best fruit growers, but a brief discussion of the subject may be of value.

Causes of Unfruitfulness

Probably the most frequent questions asked by orchardists relate to the barrenness of orchards and the causes of unfruitfulness.

There are many conditions which prevent a normal development of bloom and set of fruit. The following may be enumerated:

Rapid Wood Growth

It has been often observed that trees making very rapid wood growth fail to bear heavy crops of fruit. This is well illustrated in the case of young trees which fail to bear during the first years of their growth. The reason for this is not well understood, but it is fully established that the growth and reproductive forces are in a measure alternative and that whatever favors the one will retard

the other. While over-rapid growth always tends to lessen the fruitfulness of a tree, lack of food or insufficient nourishment will produce the same effect. The remedy in either case is obvious and the condition is readily corrected.

Diseases Attacking Bloom and Unfavorable Weather Conditions

One of the most frequent causes of failure to set fruit is due to the attack of bloom by fungi. The brown rot of stone fruits and the scab of apple is often responsible for failures which the grower attributes to frost or winter freezing. These diseases not only attack and kill the crop of bloom but they may so injure the tree as to prevent the formation of a crop of bloom for the following year. It is probable that many diseases act in an indirect way to prevent fruitfulness. In addition to actual parasitic diseases, unfavorable weather may result in pathological conditions which prevent a set of fruit; or, on the other hand, they may simply prevent pollination, which has the same result. More than once we have noted a failure in crop due entirely to continued rainfall during the blooming season.

The effect of winter freezing and frost is largely beyond the control of the grower and need not be discussed here. Other minor causes of unfruitfulness might be enumerated, but it is our purpose to discuss only the chief causes in such manner as will illustrate the use and value of the bloom charts published below. Probably the chief and most frequent cause of unfruitfulness in orchards is due to self-sterility and the lack of pollenizers for the self-sterile varieties.

Self-Sterility and Mixed Planting

Self-sterility may be defined as the inability of certain varieties to set fruit when offered only their own pollen. Other minor causes such as imperfect pistils and insufficient supply of pollen may be responsible for sterility in flowers, but such defects are not usually numerous enough to affect the crop materially. Self-sterility is due to the impotency of the pollen of certain varieties toward its sis-

terhood of pistils. This pollen may be quite virile on other flowers but has no affinity for its own. Waite was the first investigator in this country to give this subject close study, and his work has fully demonstrated the fact that many varieties of both pear and apple are either partially or wholly unfruitful when planted in large blocks to themselves. Waite also found that even where self-sterility did not prevail that cross pollination among varieties resulted in better development of fruit. Waugh has made exhaustive studies on this subject so far as it relates to plums and his conclusions are that practically all varieties of native plums and many of the Japanese group are unable to set fruit without the pollen of a second variety. Fletcher has added the further knowledge that self-sterility and self-fertility are not constant varietal characters, but depend to some extent on climatal or other environmental conditions. The subsequent studies of many investigators and the general experience of orchard practice confirm these conclusions; and the majority of well informed fruit growers now consider mixed planting a necessity. The practical question at once arises: What variety shall be selected as pollenizer for any given sort.

Selection of Pollenizer

Two factors must be taken into consideration in the selection of varieties for cross-pollination. First, there must exist a mutual affinity between the two; and secondly, they must bloom at practically the same time.

The subject of mutual affinity is a very important and interesting one, and has a direct bearing on the whole problem. But, thus far, little is known regarding such affinities, and the way to further knowledge is beset by so many obstacles that few investigators have the courage to undertake exhaustive research along this line. We have some knowledge of the subject so far as it relates to different groups of the same fruit, but this knowledge should be extended to the relation between varieties of the same group if we are to be in a position to give a definite

answer to the question suggested above. It is common knowledge that European or *Domestica* plums cross with difficulty on other types of this fruit, and that this group should, therefore be considered separately and apart from other plums when selecting cross pollenizers. On the other hand, all groups of native plums together with the Japanese varieties interpollinate rather freely, and thus we may be quite indifferent as to group relations when considering varieties falling under these heads. However, we are not prepared to say whether or not there is any difference in the degree of affinity between varieties of the same group, or if such affinity does exist whether it is a constant character or not. Until we are able to answer definitely these questions, the bloom chart is the only safe guide we have in selecting varieties for the purpose of cross-pollination. Waugh has probably given this problem more attention than any other student, and his work has led him to lay very little stress on mutual affinity in his latest publications on this subject. In a number of preliminary hand cross-pollinations with apples at this station, the results indicate that the female parent to the cross is quite indifferent to the kind of pollen offered so long as it is of another variety of apple and is in good condition; but our trials have not been sufficiently extensive to draw positive conclusions.

If these conclusions are correct, then the bloom chart is even more valuable than at first supposed; but in any case it must always be consulted if we are to practice mixed planting with success. Planting together varieties of different blooming periods does not meet the needs in the case, but the kinds that have practically the same blooming period should be selected. Although a number of experiment stations have published blooming data for the benefit of the grower, yet none of these apply to the Virginia planter. It is a well known fact that the relative blooming period of a series of varieties will not be the same for different localities, especially if they be remote from each other. No one chart can be constructed that will apply with equal

force to all sections of the United States. However, charts that apply to other sections have some value and should be consulted in the event that there is lack of more definite information. Though Virginia has a rather variable climate, the territory covered is not so extensive, but that data taken in one locality will apply in a fair degree to the rest of the state.

The chart on pp. 656-7-8-9 is therefore expected to serve as a safe guide to the Virginia fruit grower. It has been compiled from a large mass of notes extending over a period of 13 years; the number of observations, each representing a different year, is given in the left-hand column just after the variety name. The number of years covered guarantees a safe norm, whereas norms reached by only three or four observations would hardly appear to be reliable. The apple orchard was planted in the spring of 1889, but all notes on apple collected prior to 1896 have been disregarded because of the unreliability of bloom notes from trees during their earlier stages of growth.

The next step in this work should be the collection of blooming data from different sections of the state with the view of developing a phenological map for Virginia, and to this end we solicit the cooperation of all those who are interested in this subject. Bloom note forms and instructions will be furnished those desiring to aid us in these studies.

Explanation of Chart

In the charts following the blooming period of each given variety is represented by the starred line following the name. This line begins with the average recorded for first bloom open and extends two days beyond the period of full bloom. While flowers remain receptive for more than two days after full bloom during cloudy weather, this is not the case if conditions are favorable to pollination. The different fruits or groups of same are arranged in order of their blooming, as this arrangement appears best for comparisons.

For APPLES, see *Pollination*, under *Apple*.

Normal Bloom Chart

PEARS	No of Observations	APRIL														MAY						
		16	17	18	19	20	21	22	23	24	25	26	27	28	29	30	1	2	3	4	5	6
Dewey's Prem	13	*	*	*	*	*	*	*	*	*	*	*	*	*	*	*	*	*	*	*	*	*
Kieffer	13	*	*	*	*	*	*	*	*	*	*	*	*	*	*	*	*	*	*	*	*	*
Leconte	9	*	*	*	*	*	*	*	*	*	*	*	*	*	*	*	*	*	*	*	*	*
Lawson	10	*	*	*	*	*	*	*	*	*	*	*	*	*	*	*	*	*	*	*	*	*
Anjou	12	*	*	*	*	*	*	*	*	*	*	*	*	*	*	*	*	*	*	*	*	*
Lawrence	12	*	*	*	*	*	*	*	*	*	*	*	*	*	*	*	*	*	*	*	*	*
Maury	13	*	*	*	*	*	*	*	*	*	*	*	*	*	*	*	*	*	*	*	*	*
Marguerite	13	*	*	*	*	*	*	*	*	*	*	*	*	*	*	*	*	*	*	*	*	*
Rutter	10	*	*	*	*	*	*	*	*	*	*	*	*	*	*	*	*	*	*	*	*	*
Clairgeau	13	*	*	*	*	*	*	*	*	*	*	*	*	*	*	*	*	*	*	*	*	*
Clapp	9	*	*	*	*	*	*	*	*	*	*	*	*	*	*	*	*	*	*	*	*	*
Easter Beurre	9	*	*	*	*	*	*	*	*	*	*	*	*	*	*	*	*	*	*	*	*	*
Howell	12	*	*	*	*	*	*	*	*	*	*	*	*	*	*	*	*	*	*	*	*	*
Osband	12	*	*	*	*	*	*	*	*	*	*	*	*	*	*	*	*	*	*	*	*	*
Sum. Doyenne	9	*	*	*	*	*	*	*	*	*	*	*	*	*	*	*	*	*	*	*	*	*
White Doyenne	10	*	*	*	*	*	*	*	*	*	*	*	*	*	*	*	*	*	*	*	*	*
Bartlett	12	*	*	*	*	*	*	*	*	*	*	*	*	*	*	*	*	*	*	*	*	*
Bosc	11	*	*	*	*	*	*	*	*	*	*	*	*	*	*	*	*	*	*	*	*	*
Boussock	10	*	*	*	*	*	*	*	*	*	*	*	*	*	*	*	*	*	*	*	*	*
Early Wilder	8	*	*	*	*	*	*	*	*	*	*	*	*	*	*	*	*	*	*	*	*	*
Malines	11	*	*	*	*	*	*	*	*	*	*	*	*	*	*	*	*	*	*	*	*	*
Louise	11	*	*	*	*	*	*	*	*	*	*	*	*	*	*	*	*	*	*	*	*	*
Pound	10	*	*	*	*	*	*	*	*	*	*	*	*	*	*	*	*	*	*	*	*	*
Seckel	9	*	*	*	*	*	*	*	*	*	*	*	*	*	*	*	*	*	*	*	*	*
Sheldon	10	*	*	*	*	*	*	*	*	*	*	*	*	*	*	*	*	*	*	*	*	*
Superfine	10	*	*	*	*	*	*	*	*	*	*	*	*	*	*	*	*	*	*	*	*	*
Lucrative	12	*	*	*	*	*	*	*	*	*	*	*	*	*	*	*	*	*	*	*	*	*
Buffum	9	*	*	*	*	*	*	*	*	*	*	*	*	*	*	*	*	*	*	*	*	*
Duchess Precose	10	*	*	*	*	*	*	*	*	*	*	*	*	*	*	*	*	*	*	*	*	*
Flemish Beauty	7	*	*	*	*	*	*	*	*	*	*	*	*	*	*	*	*	*	*	*	*	*
Idaho	5	*	*	*	*	*	*	*	*	*	*	*	*	*	*	*	*	*	*	*	*	*
Elizabeth	8	*	*	*	*	*	*	*	*	*	*	*	*	*	*	*	*	*	*	*	*	*
Tyson	9	*	*	*	*	*	*	*	*	*	*	*	*	*	*	*	*	*	*	*	*	*
Vicar	8	*	*	*	*	*	*	*	*	*	*	*	*	*	*	*	*	*	*	*	*	*
Souvenir	8	*	*	*	*	*	*	*	*	*	*	*	*	*	*	*	*	*	*	*	*	*
Bessemiankee	1	*	*	*	*	*	*	*	*	*	*	*	*	*	*	*	*	*	*	*	*	*

Normal Bloom Chart

CHERRIES	No. of Observations	APRIL															
		15	16	17	18	19	20	21	22	23	24	25	26	27	28	29	30
Ey. LaMaurie	8	*	*	*	*	*	*	*	*	*	*	*	*	*	*	*	*
Mezel	11	*	*	*	*	*	*	*	*	*	*	*	*	*	*	*	*
Windsor	13	*	*	*	*	*	*	*	*	*	*	*	*	*	*	*	*
Ey. Purple	12	*	*	*	*	*	*	*	*	*	*	*	*	*	*	*	*
Sparhawk	11	*	*	*	*	*	*	*	*	*	*	*	*	*	*	*	*
Coe	13	*	*	*	*	*	*	*	*	*	*	*	*	*	*	*	*
Gov. Wood	11	*	*	*	*	*	*	*	*	*	*	*	*	*	*	*	*
Rockport	13	*	*	*	*	*	*	*	*	*	*	*	*	*	*	*	*
Tartarian	13	*	*	*	*	*	*	*	*	*	*	*	*	*	*	*	*
Tradescant	11	*	*	*	*	*	*	*	*	*	*	*	*	*	*	*	*
Elton	10	*	*	*	*	*	*	*	*	*	*	*	*	*	*	*	*
Hortense	12	*	*	*	*	*	*	*	*	*	*	*	*	*	*	*	*
Ostheime	11	*	*	*	*	*	*	*	*	*	*	*	*	*	*	*	*
Olivet	11	*	*	*	*	*	*	*	*	*	*	*	*	*	*	*	*
Napoleon	10	*	*	*	*	*	*	*	*	*	*	*	*	*	*	*	*
Schmidt	12	*	*	*	*	*	*	*	*	*	*	*	*	*	*	*	*
Philippe	12	*	*	*	*	*	*	*	*	*	*	*	*	*	*	*	*
Kirtland Mary	10	*	*	*	*	*	*	*	*	*	*	*	*	*	*	*	*
May Duke	11	*	*	*	*	*	*	*	*	*	*	*	*	*	*	*	*
Montmorency	11	*	*	*	*	*	*	*	*	*	*	*	*	*	*	*	*
Richmond	9	*	*	*	*	*	*	*	*	*	*	*	*	*	*	*	*

H. L. PRICE,
Blacksburg, Va.

Blueberry or Huckleberry

It seems not quite settled where the name huckleberry originated as applied to a species of bush fruits of the genus *Gaylussacia*. They grow principally in the Northern hemisphere in North America and North Britain. The plant varies greatly in size from about six inches in height to ten feet. The berries are small, but highly prized for their flavor; not highly profitable commercially because of the amount of labor necessary in picking and marketing. Yet no one who has picked the native wild huckleberry would desire to see them displaced from the markets of the world. Therefore considerable effort has been made to improve the varieties so that they can be marketed profitably in competition with other fruits.

GRANVILLE LOWTHER

Improvement of Blueberries

C. B. SMITH

An investigation of this subject has been undertaken by the Maine station. In a report of that station it is stated that blueberries are found growing in great quantities in many of the Eastern and Northern states on soils which are, as a rule, of little or no value for general agricultural purposes, but that while the berries have been highly prized as an article of food from the earliest colonial period, "practically no attention has been given to the cultivation and systematic improvement of the fruit." Plants have from time to time been introduced into gardens with good results, and the management of blueberry barrens has occasionally been undertaken. An account of an experiment of the latter kind is reported by the Maine station. The blueberry lands described consist of 40,000 acres belonging to one owner.

The land is divided into several parts, each of which is leased to some responsible party who assumes the whole care of burning over the land, keeping off trespassers, harvesting, and marketing the fruit. * * * Every year a certain section of each "lease" is burned over. This burning must be done very early in the

spring before the ground becomes dry, otherwise the fire goes too deep and humus is burned from the ground and most of the bushes are killed. Many hundred acres of what would be the best part of the barrens have thus been ruined. The method most commonly used in burning a given area is for the operator to pass around the section to be burned, and drag after him an ordinary torch or a mill lamp. He then retraces his steps over the burned area, setting after-fires in the portions which have escaped, and back-firing if there is danger of spreading unduly over areas which it is desired to leave unburned. A device which was found in use by one party consists of a piece of half-inch gas pipe bent at the end at an angle of about 60 degrees. The end opposite the bent portion is closed with a cap or plug, and in the other end, after filling the pipe with kerosene, is placed a plug of cotton waste or tow. This device is regarded as superior to the lamp or torch as it is more easily handled.

Systematically treated blueberry fields are burned over about once every three years. This burning renews the bushes and tends to check the growth of underbrush.

The early ripening fruits on these lands are picked by hand and sent to the city markets, usually in quart boxes. Later in the season the fruit is sent to the canneries. On the older barrens, especially on areas which are to be burned over the following spring, the fruit is gathered with a "blueberry rake."

This is an implement somewhat similar to the cranberry rake in use on Cape Cod, and may be likened to a dust pan the bottom of which is composed of stiff parallel wire rods. The fruit may be gathered much more quickly and more cheaply by means of the rake. The bushes are, however, seriously injured by the treatment. In no case should the rake be employed in gathering the high-bush blueberries.

At the New York state station considerable difficulty was met with in growing seedling plants of the high-bush huckleberry (*Vaccinium corymbosum*) because

of the delicate nature of the young plants and the very careful treatment which they require. The same station made an examination of the flowers of this species in order to learn at what time the stamens yield their pollen.

This seems to be given off immediately before and for a short time after the corolla opens. By opening the corolla of flowers about to expand and jarring the blossoms vigorously over a glass slide, we secured pollen in considerable quantities, which is an indication that the flowers may be at least in part self-fertilized. Nothing appeared in the structure of the flowers to render artificial crossing difficult.

The experience of one grower in Massachusetts leads him to the following conclusions:

(1) It [the high-bush blueberry] does not take kindly to garden cultivation; (2) it is very difficult to propagate from the seed; (3) it is somewhat difficult to graft, but patience and a little of the "know how" will overcome all of these. If grown in the garden, (1) they must be on the north side of a board fence or in the shade of trees and the ground must be mulched with leaves or evergreen boughs; (2) let the seed get fully ripe and drop, then sow in a shady place; (3) graft small bushes at the surface of the ground and cover most of the scion with moist earth.

Success in growing blueberries has been attained by all of these methods.

Another grower reports that he has been very successful in growing high-bush blueberries on a poor, rocky, upland soil. The bushes improved much in thrift and yielded from three to four times as much fruit as wild bushes growing in pastures and swamps and the berries were from 25 to 30 per cent larger. He advises setting plants 6 feet apart each way and mulching with strawy manure in the fall.

The results of the experiments thus far conducted would seem to show that the blueberry is subject to much variation and is greatly improved by cultivation. Blueberries are as yet but little cultivated, but the few attempts that have been made

toward their improvement indicate that with care satisfactory results may be obtained. Meanwhile natural blueberry barrens may be made to give increased yields by systematic burning and care, and thus these lands, otherwise worthless for agriculture, made sources of profit.

References

For an account of exhaustive experiments in Swamp Blueberry Culture, see Bulletin 193, Bureau of Plant Industry, by F. V. Colville.

Card, Bush Fruits.

Bailey, New Cyclopaedia of American Horticulture.

Brazil Nut

The seeds of a Brazilian tree, called also Castanea, Cream nut, Nigger toe, Paranut. It belongs to the natural order *Myrtaceae*, species *Bertholletia excelsa*. The tree often attains a height of 150 feet, and a diameter of four feet. It has bright green, leathery leaves, two feet or more in length, and six inches in width. It bears cream colored flowers and a very hard shelled fruit six inches or more in diameter, containing about 20 three sided wrinkled seeds, which are used for desert, confectionery, and for the manufacture of an expressed oil used in oil painting, lubricating fine machinery, and in lighting. This tree covers large tracts of land in Northern Brazil, along the Amazon and Orinoco rivers.

GRANVILLE LOWTHER

Bread Fruit

Artocarpus incisa

A tree of the natural order *Urticaceae*, native of the Indian archipelago and of the Southern Pacific islands. It attains a height of 30 or 40 feet; is often limbless for half its height, bears leathery, glossy dark green, three to nine-lobed leaves, one to three feet long; has compact club-shaped, yellow catkins of male flowers, 9 to 15 inches long, and sub-globular heads of female flowers, with spongy receptacles; and usually seedless, spheroidal fruits, at first green, later brown, and lastly yellow, six inches or more in diameter, hanging by thick stalks singly or

in clusters of two or three from the smaller branches. The rough rind is irregularly marked in squares and other figures with raised centers. The unripe fruit contains a milky juice, and when in the edible stage it resembles fresh bread, being white and mealy. It is then slightly tart. Later it becomes yellow, juicy, and tastes of decay. In tropical countries where it has been introduced and particularly in its original home, the fruit is highly valued as a nutritious food, being prepared for use in various ways.

When baked it resembles plantain rather than wheaten bread, being sweetish, slightly astringent, but otherwise almost tasteless. When fresh fruits cannot be procured, it is sometimes slightly fermented, beaten to a pasty mass, and so used.

Another common way of preparing it is to beat it to a paste with cocoanut milk and to serve it mixed with bananas, plantains, etc. Since the trees produce two or three crops annually, and since the bearing seasons of different varieties overlap more or less, the fruit may be obtained during the greater part of the year. Not alone for the fruit is the tree valuable; in the South Sea Islands its fibrous inner bark is woven into cloth resembling, but inferior in softness and whiteness to that made from the paper mulberry which is similarly employed in those islands; the gummy exudation from the bark, boiled with cocoanut oil is used for caulking canoes, pails, etc.; the beautiful yellow wood is light and soft, but when exposed to the air becomes dark like mahogany, and is used for canoes, furniture, and the interior work in houses.

The tree has been cultivated to a slight extent in Southern Florida, but the fruits rarely appear even in the most southern markets of the United States, because they do not bear shipment well, and unless used very soon after being gathered become hard and disagreeable in taste. For an account of the introduction of the bread fruit tree into the West Indies in the last decade of the 18th Century, when such feats were more difficult and less common than a century later, see Curtis'

"*Botanical Magazine*" (pp. 2869-71). A near relative of the bread fruit trees is the jack.

The Americana Bread Nut

Brosimum alicastrum

A tree of the natural order *Urticaceae*, a native of the West Indies and closely related to the bread fruit. The tree, which is very large, bears shining lance-shaped leaves; globose catkins of male and female flowers on different trees; and yields a gummy, milky juice from its bark. The round, yellow fruits (drupes), which are about three inches in circumference, contain a single seed. When roasted or boiled they are used like bread, and having a flavor which resembles hazel nuts, form a pleasant food. In the United States the tree has not been cultivated.

THE AMERICANA BROCCOLI, *How Grown in Alaska*. See *Alaska*.

See *Kale*.

BRUSH LAND, *Preparation of*. See *Apple Orchard, Preparation of Ground*.

Brussels Sprouts

This vegetable belongs to the Cabbage family. The stem is usually two or more feet high with leaves, and at the base of each leaf is a small cabbage which is seldom more than two inches in diameter. These miniature cabbages are much more delicate in flavor than the ordinary cabbages, and are the parts eaten. In growing, it requires the same treatment as the cabbage, except that they may be grown nearer together. It is highly esteemed by some persons, as an article of food, but has not come into general use; probably owing to the fact that in our markets, not as much attention is paid to quality as to general appearance. The Dwarf Brussels is the variety most highly recommended.

The plant is a biennial, a native of Europe, and like the cabbage succeeds well on almost any deep rich soil.

Varieties

Scrymger Giant.

Long Island Improved.

FOR DISEASES AND PESTS, see under *Cabbage*.

GRANVILLE LOWTHER

BUCKWHEAT, See *Apple Orchard, Cover Crops*.

BUDDING, See *Apple, Propagation of; Peach, Propagation of, etc.*

Breeds of Fruits and Their Survival

Plants are coming into as much prominence as are animals by breeding and it is eminently proper to speak of the breeds of farm crops or the breeds of fruits. A breed is the result of domestication, at least we may say so if we apply the term breed to a plant which we have artificially endowed with a pedigree. Perhaps it is taking liberties with the dictionary to call an improved kind or type of apple a breed, but no other word conveys just the meaning I desire. For example, if I speak of the Wealthy apple as a breed of apples we naturally think of the general characteristics of the Wealthy apple and still allow for a considerable variation in different localities due to the action of soil and climate, and it is with special reference to apples that I would speak of the survival of breeds or varieties if you prefer that word.

Fruit growers in the West have come to recognize certain climate and soil areas as suited to particular kinds and varieties of fruits. This is especially true in California, where in one valley or even in one portion of a valley, the farmers determine one particular kind that succeeds best and then grow that kind almost or quite exclusively, while in an adjoining valley or section a different fruit will be grown. So, too, a state, or one particular section of a state, becomes famous for some particular breed of fruit. The California Belle Fleur apple in uniform boxes of uniformly graded fruit now finds its way into many markets. Southwestern Colorado is becoming a Jonathan region. Other parts of the West are growing Wagener, or Spitzenburg, or Rome Beauty, or McIntosh Red, or Wealthy, and so on. At the local apple shows some one variety usually predominates. Of course there are a number of hardy and widely adapted fruits that appear in every exhibition. We

nearly always find among the apples given most prominence at the county and state fairs in the mountain region well grown specimens of Yellow Transparent, Duchess, Wealthy, Wolf River, Alexander, Longfield, Northwest Greening, Fameuse, Bietigheimer, McMahon, Gano and others, including most of the large and small crabs. It often occurs at these shows that one or more varieties will be shown that no one is able to name.

In the pioneer days of apple growing, the would-be horticulturist has had no guide and the only judgment with which he made selections of varieties was a memory of some good or favorite kind which he was acquainted with in his boyhood days. Usually he has been more or less skeptical about the success of any domesticated thing which he would transplant to untried soils, and he is ready to try anything new which is called to his attention. Tree agents are not slow about recommending anything of which their nurseries have stock for sale. It is said that some five thousand varieties of apples are known in the world. Of all the varieties planted in any locality, a comparatively small number have survived. Perhaps hundreds of Wyoming ranchmen and farmers have purchased and planted quince and apricot trees, but I have yet to hear of or see a ripe fruit of either quince or apricot in this state. Of the hundreds of varieties of apples the successful commercial kinds may be counted on the fingers of both hands for the whole state.

There are several reasons why the many varieties do not survive. In the first place fruits are more or less domesticated and they are transferred to a new region before the soil has been tamed and made ready for them. Then the western pioneer has been doing things in a large way and generally fails to attend to the necessary little details of plant culture. Someone has said that those plants which require the most care are given the best cultivation, inferring that the apple is so easily grown that it is subjected to general lack of care and neglect and this condition has certainly fitted our attempts

in the mountain region. Finally, the reason of most importance, perhaps, is that difficult to define something in the plant constitution called adaptability.

We look upon plants and animals as creatures of environment. They are what they are because of certain conditions of food supply along with climatic and social influence. But organic life has within itself an inherent power of variation and adaptability which enables some individuals or species to survive under changed conditions of life and food supply. The fact that characteristics may appear in one place that fit a plant for life in a different environment is now recognized. The great Dutch botanist and plant breeder, DeVries, goes so far as to advocate that most of the desert flora is probably made up of varieties that had their origin by mutation in a more favorable location and by migration have found a home in the arid soils which they do not enjoy, but which they are able to endure. Under proper irrigation and in soils rich in plant foods, with favorable climate, plants brought to the arid region would seem to have better chance for growth and development than in some of the regions where they originate, but we must recognize that the conditions of life are so different that there must be a large range of adaptability in the species or there must be some dominant character which definitely fits the variety to this different environment, or it will fail. In my opinion these characteristics are much more apt to appear in the region during the time the plant is growing under those particular conditions, and herein lies the reason for securing our plants or seeds at home or at least from a place where the conditions are not less severe.

*B. C. Buffum, in Address before Wyoming State Board of Horticulture.

BUD WORM. See *Peach Twig Borer*.

Buffalo Berry

Lepargyrae argentea, Greene

Shepherdia argentea, Nutt.

The buffalo berry is a tall shrub or small tree, a near relative of the Russian olive which it resembles in its sil-

very foliage and yellowish flowers. The fruit is rather sour, slightly resembling that of ripe cranberries, spherical in shape, about the size of large currants or small gooseberries, and of a reddish color. The tree is very hardy, with thorns that enable it to grow where other small fruits would be destroyed by stock, or other unfavorable surroundings. However, it is not largely cultivated, because in competition with other fruits like currants, gooseberries, blackberries, raspberries, etc., it seems not to be preferred by the trade.

F. W. Card, in the *New Cyclopaedia of American Horticulture*, says: "The buffalo berry has long been before the public, but it is only within the last few years, that it has attained any prominence as a fruit plant. In Hovey's *Magazine of Horticulture* for 1841, page 251, it is mentioned as frequently cultivated, indicating that it had found its way into our gardens earlier than the blackberry. Its position today bears evidence that no such place was awaiting it as stood ready for the blackberry, or that if there were, it has lamentably failed in filling it. The plant did not find its place as a cultivated shrub until the settlement of the West created a demand for hardy and drouth resisting fruits."

It is the hardy drouth resisting qualities of this fruit that has brought it into prominence in the mountainous and semi-arid regions of the West. It may therefore be found growing on the semi-arid plains east of the Rocky mountains in Montana, Wyoming, Colorado, New Mexico, Kansas, Nebraska, the Dakotas, and in parts of Canada.

It is very tenacious of life, and is easily propagated by seeds, by suckers, or by cuttings. Its fruit is used mostly for jellies and has a very pleasant taste. As a fruit adapted to conditions where other fruits will not succeed, it has considerable value; but in competition in the markets with fruits grown for commercial purposes, in regions adapted to fruit growing, it will not succeed.

GRANVILLE LOWTHER

