

D593  
.K76

# Acidity and Acidimetry of Soils

BY

HENRY GRANGER KNIGHT

B.A. University of Washington, 1902

M.A. University of Washington, 1904

21-27090

Thesis Submitted in Partial Fulfillment of the Requirements  
for the Degree of Doctor of Philosophy in Chemistry  
in The Graduate School of the University  
of Illinois, 1917

---



# Acidity and Acidimetry of Soils

BY

HENRY GRANGER KNIGHT

B.A. University of Washington, 1902

M.A. University of Washington, 1904

---

Thesis Submitted in Partial Fulfillment of the Requirements  
for the Degree of Doctor of Philosophy in Chemistry  
in The Graduate School of the University  
of Illinois, 1917

---

(Reprinted from the Journal of Industrial and Engineering Chemistry, vol. 12, no. 4, p. 340; no. 5, p. 457; no. 6, p. 559. April, May and June 1920.)

S 593  
.K76

LIBRARY OF CONGRESS  
RECEIVED  
FEB 28 1921  
DOCUMENTS DIVISION

## ACIDITY AND ACIDIMETRY OF SOILS.<sup>1</sup> I—STUDIES OF THE HOPKINS AND PETTIT METHOD FOR DETERMINING SOIL ACIDITY

By Henry G. Knight

OKLAHOMA AGRICULTURAL AND MECHANICAL COLLEGE, STILLWATER,  
OKLAHOMA

Received October 14, 1919

The Hopkins and Pettit method of determining soil acidity<sup>2</sup> proposed in 1902 is essentially as follows: 100 g. of soil are shaken in a bottle of 400 cc. capacity with 250 cc. of 5 per cent commercial common salt solution for 3 hrs. 125 cc. of the clear liquid are taken off, boiled to expel carbon dioxide, and titrated using phenolphthalein as an indicator. The results are multiplied by 3 as a factor to determine the total amount of base required. Later<sup>3</sup> a normal solution of potassium nitrate was substituted for the 5 per cent commercial common salt and the factor 2.5 recommended. The modified method is still the provisional method of the A. O. A. C. for determining the acidity of soils.

Veitch<sup>4</sup> criticizes the Hopkins method upon the grounds that it indicates only the apparent need for lime or the most urgent need, and claims further that the acidity shown by this method is largely due to aluminates. He also notes that there is a great discrepancy between the Hopkins method and that proposed by himself<sup>5</sup> upon soils high in organic matter. Harris<sup>6</sup> claims that the acidity shown by this method is due to selective ion absorption by the soil colloids, basing his views upon the fact that the acidity shown by the extract is dependent upon the character of the salts used. Freer<sup>7</sup> also holds this view. Truog<sup>8</sup> strenuously combats the theory of colloidal absorption

<sup>1</sup> From a thesis submitted to the faculty of the University of Illinois in partial fulfillment of the requirements for the degree of Doctor of Philosophy. Acknowledgment is made of many helpful suggestions and criticisms from Prof. C. G. Hopkins and Prof. A. H. Noyes.

<sup>2</sup> Nineteenth Annual Proceedings, O. A. C., U. S. Dept. of Agr., Bureau of Chemistry, *Bulletin* 73 (1902), 114.

<sup>3</sup> U. S. Dept. of Agr., Bureau of Chemistry, *Bulletin* 107 (1908), 20; Hopkins, "Soil Fertility and Permanent Agriculture," 1910, 566.

<sup>4</sup> *J. Am. Chem. Soc.*, 26 (1914), 637.

<sup>5</sup> *Ibid.*, 24 (1902), 1120.

<sup>6</sup> Michigan Agr. College and Station, *Bulletin* 19 (1914).

<sup>7</sup> Penn. Dept. Agr., *Bulletin* 261 (1915), 106.

<sup>8</sup> *J. Phys. Chem.*, 20 (1916), 157.

and brings evidence to support the view of Hopkins that the reaction is one of double decomposition between the acids or acid salts in the soil and the neutral salt solution. Parker<sup>1</sup> concluded from analysis of extracts prepared by treating soils with potassium chloride and potassium acetate that the base was absorbed to a little greater extent than it was liberated by the soil and that the excess of the anion should be accounted for by the presence of the corresponding acid. Brogue<sup>2</sup> states that it has been repeatedly proven that the base liberated by the soil is usually not merely equivalent to the base absorbed from the solution. Sullivan,<sup>3</sup> Morse and Curry,<sup>4</sup> Abbott, Conn and Smalley,<sup>5</sup> Ruprecht,<sup>6</sup> and others have noted the presence of aluminum and iron in salt extracts from acid soils. Rice<sup>7</sup> concludes from hydrogen-ion concentration studies upon 31 soils using the indicator method of Sørensen<sup>8</sup> that when so-called acid soils are shaken with salt solutions part of the cation of the salt is absorbed and an equivalent quantity of the base from the soil is given up to the solution.

It was to test the above points that the following investigations were made.

#### EXPERIMENTAL

Harris obtained different lime requirements for soils by repeated shaking with different salt solutions. These experiments were repeated in this laboratory using yellow-gray silt loam, and similar differences were obtained as was reported by Harris for different salts. As Hopkins claims that the reaction between the neutral salt solution and the soil is one of equilibrium, the end reaction would be practically impossible to realize by such a treatment. To overcome the objections which would arise from the above method provisions were made for forcing the salt solutions through the soil, so that the soil particles would be continually bathed by fresh solutions.

Twenty grams of yellow-gray silt loam<sup>9</sup> were placed

<sup>1</sup> THIS JOURNAL, 6 (1914), 831.

<sup>2</sup> J. Phys. Chem., 19 (1915), 665.

<sup>3</sup> U. S. Geol. Survey, Bulletin 312 (1907).

<sup>4</sup> New Hampshire Agr. Station, Report 1906-08, 271.

<sup>5</sup> Indiana Agr. Expt. Station, Bulletin 170 (1913).

<sup>6</sup> Mass. Agr. Expt. Station, Bulletin 161 (1915).

<sup>7</sup> J. Phys. Chem., 20 (1916), 214.

<sup>8</sup> Biochem. J., 21 (1909), 131; Walpole, Biochem., 5 (1911), 207; 8 (1914), 628.

<sup>9</sup> Sample No. 1. Subsoil from Southern Illinois. Lime requirement: Hopkins Method 4.2T., Veitch Method 5.6T., per acre of soil of 2,000,000 lbs.

upon a dry filter paper and the salt solution was allowed to filter through. The filtrate was boiled and treated with 0.04 *N* potassium hydroxide at room temperature using phenolphthalein as an indicator, with the results shown in Table I.

TABLE I—ACIDITY OF DIFFERENT FRACTIONS OF VARIOUS SALT SOLUTIONS FILTERED THROUGH AN ACID SOIL

Salt Used	Cc. 0.04 <i>N</i> KOH Required for				Total	Equivalent to T. CaCO <sub>3</sub>
	100 cc.	250 cc.	250 cc.	250 cc.		
<i>N</i> KNO <sub>3</sub> .....	36.40	2.8	1.2	0.5	40.5	4.05
<i>N</i> KCl.....	35.95	4.3	2.1	0.5	39.95	3.99
<i>N</i> NaNO <sub>2</sub> .....	26.50	9.2	1.8	1.4	38.9	3.89
<i>N</i> NaCl.....	31.20	6.4	1.4	...	39.0	3.90
<i>N</i> CaCl <sub>2</sub> .....	31.40	5.4	1.3	0.5	38.6	3.86

The greatest difference shown is 0.19 T., calculated as calcium carbonate, which may easily be accounted for by errors in reading the end-point. It will be noted that the acidity of the sodium nitrate extract was quite marked even after 600 cc. had filtered through, while the first 100 cc. showed the lowest acidity. That none of the extractions were carried to completion is evident, but all, with the possible exception of that with sodium nitrate, were carried to a point beyond which it was impossible to measure the acidity with any degree of accuracy by the ordinary indicator methods. The calcium salt extract would be expected to show a slower reaction after the first surface reaction because of the greater insolubility of calcium compounds which would be formed upon the surface of the soil grains.

INDICATOR EFFECTS—In the first two series of extracts, a precipitate which had a rather marked effect upon the indicator was always formed in considerable quantity. The pink color produced by the addition of a slight excess of base disappeared after a time even when the titrating flask was tightly stoppered. By the further addition of base the color could be brought back. The end-point is also markedly influenced by the amount of indicator present. It is quite apparent that the indicator is absorbed to a marked extent by the precipitate, and instead of the simple equilibrium

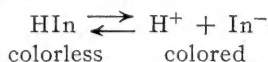

there must be taken into consideration the equilibrium with the absorbed indicator

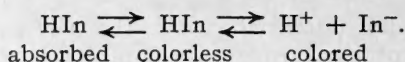

Two equal quantities of a potassium salt extract of an acid soil gave readings, as shown in Table II, which clearly indicate the variation in results which may be obtained by using different amounts of indicator.

TABLE II—EFFECT OF DIFFERENT AMOUNTS OF INDICATOR UPON TITRATION END-POINT

Phenolphthalein Used Drops	0.04 N KOH Required Cc.
4	62.7
10	61.1

In several instances a point was reached which showed no visible color change with four or five drops of indicator, while upon the addition of larger quantities a marked color change was observed. To overcome as far as possible the variation due to the indicator the same quantity was used in each case unless otherwise stated.

EFFECT OF TEMPERATURE UPON TITRATION—The temperature at which the titration is carried out was found to produce an effect which is shown in Table III. Two equal quantities of potassium nitrate extract were titrated with 0.04 N potassium hydroxide using the same quantity of phenolphthalein as an indicator. The only difference between the duplicates was that of temperature.

TABLE III—EFFECT OF TEMPERATURE UPON TITRATION END-POINT

Temp. ° C.	Cc. KOH
22	16.7
85	19.2

EFFECT OF TEMPERATURE UPON THE AMOUNT OF ACIDITY SHOWN—If the Hopkins method is a measure of the colloidal adsorption for the base by a soil as maintained by Harris<sup>1</sup> there should be a temperature effect which could be measured. Travers<sup>2</sup> has shown that the adsorption of carbon dioxide by charcoal decreases markedly with rise in temperature, and we may expect a similar change to be shown by soils in contact with neutral salt solutions.

To test this theory an apparatus, shown in Fig. 1, was arranged in a constant temperature electrical oven of the Freas type. The apparatus was arranged in duplicate. *a* is the receptacle for the neutral salt solution, *b* a stopcock for regulating the flow of the neutral salt through tube *d* which passes through the ventilating openings *c* provided by the manufacturers

<sup>1</sup> *Loc. cit.*

<sup>2</sup> *Proc. Roy. Soc. London*, 74 (1904), 126.



in the stock oven. The bulb *e* serves to bring the salt solution to the temperature of the oven before it runs into the receptacle *f* which contains the soil under investigation. The filtrate passes out of the apparatus through tube *g*, through ventilating openings in the oven at *c'*, and is caught in measuring flasks;

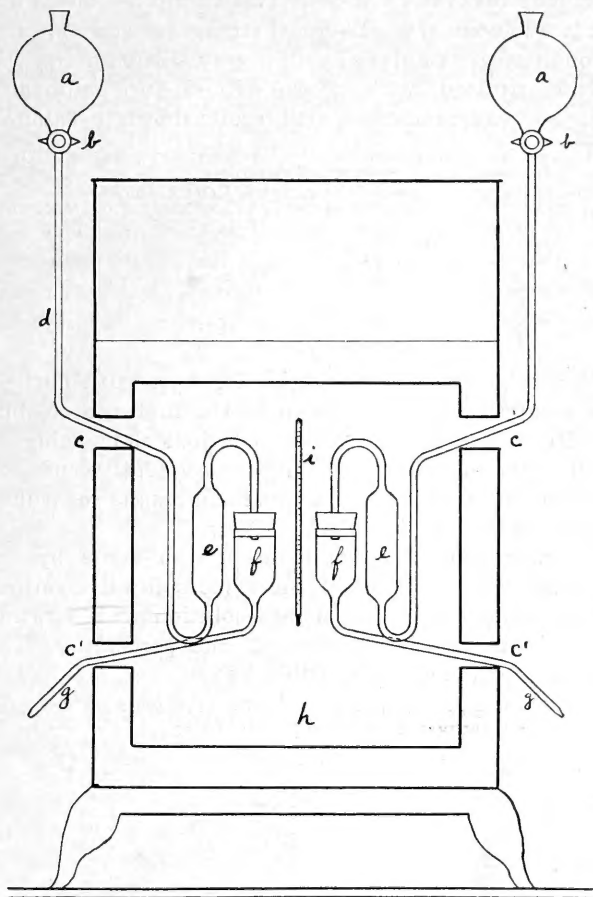

FIG. 1

*i* is a thermometer placed in the center of the oven for noting the temperature.

Twenty grams of soil were placed in the receptacle, normal potassium nitrate solution allowed to percolate through, and titrated at room temperature with results as shown in Table IV.

The temperature effect is very slight, and certainly does not indicate colloidal adsorption, unless this may be an exceptional case.

TABLE IV—EFFECT OF TEMPERATURE UPON REACTION BETWEEN ACID SOIL AND NEUTRAL SALT SOLUTION

PERCOLATE Cc.	TEMPERATURE			
	90° ± 1°		25° ± 1°	
	0.04 N KOH Cc.	CaCO <sub>3</sub> T.	0.04 N KOH Cc.	CaCO <sub>3</sub> T.
100	37.85	3.785	36.4	3.64
400	3.15	0.315	3.0	0.30
TOTAL 500	41.00	4.1	39.4	3.94

EFFECT OF STRENGTH OF SALT SOLUTION—Potassium nitrate solutions of different strengths were filtered through 20 g. samples of yellow-gray silt loam and the filtrate titrated with 0.04 N KOH, using phenolphthalein as an indicator with results shown in Table V.

TABLE V—EFFECT OF STRENGTH OF SALT SOLUTION UPON THE TOTAL AMOUNT OF ACIDITY

Fractions Cc.	Cc. 0.04 N KOH Required—		
	N KNO <sub>3</sub>	0.5 N KNO <sub>3</sub>	0.1 N KNO <sub>3</sub>
1—100	35.0	33.3	18.3
2—100	3.5	4.7	7.6
3—100	1.2	1.5	4.3
4—100	0.8	0.9	3.7
5—100	0.5	0.6	3.3
6—100			1.6
TOTAL.....	40.8	41.0	38.8
as T. CaCO <sub>3</sub> .....	4.08	4.10	3.88

It will be noted that with the stronger salt solutions the greatest acidity is shown in the first 100 cc. but rapidly falls while the weaker solutions show a higher acidity in succeeding fractions. Evidently end extractions would lead to the same end results regardless of the strength of the salt solution.

Further study of this reaction was made by extracting 10 g. samples of the same soil with various strengths of potassium nitrate solution and titrating the acid in the first 100 cc. of the percolate. The results are tabulated in Table VI.

TABLE VI—ACIDITY SHOWN IN FIRST 100 CC. FILTRATE FROM ACID SOIL, USING NEUTRAL SALT SOLUTIONS OF VARIOUS STRENGTHS

Normality of KNO <sub>3</sub>	0.04 N KOH	
	Required Cc.	Calculated as T. CaCO <sub>3</sub>
1.00	15.2	3.40
0.50	15.3	3.06
0.25	15.2	3.04
0.125	13.25	2.65
0.0625	8.00	1.60
0.0312	4.10	0.82
0.0156	1.95	0.39
0.0078	1.17	0.23

The acidity of the first portion of the extract increases with increase in concentration of the neutral salt solution.

TABLE VII—AMOUNTS OF LIME ABSORBED BY ACID SOIL FROM SOLUTIONS OF VARIOUS STRENGTH

Lime Added Calculated as T. CaCO <sub>3</sub>	Absorbed by Soil T. CaCO <sub>3</sub>	Left in Solution T. CaCO <sub>3</sub>	Final Normality of Solution
12	11.71	0.29	0.000285
14	13.56	0.64	0.00064
16	14.59	1.41	0.0014
20	16.75	3.25	0.0032
30	20.93	9.07	0.009
40	24.96	15.04	0.015

## EXAMPLES OF SO-CALLED COLLOIDAL ABSORPTION

As examples of what are usually considered colloidal phenomena the following experiments are submitted.

EXPERIMENT I—20 g. of yellow-gray silt loam were shaken with various amounts of lime contained in 200 cc. of solution for 12 hrs. and aliquot parts of the clear liquid were titrated with results as shown in Table VII.

A greater portion of the lime is absorbed from the dilute solutions than from the more concentrated, thus apparently following the colloidal absorption law.

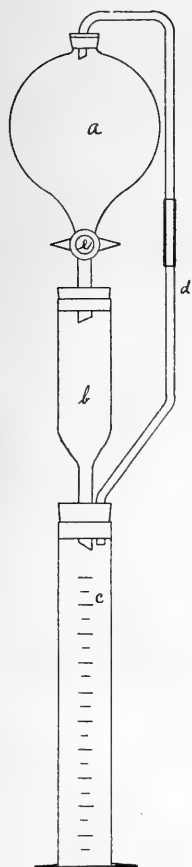

FIG. 2

EXPERIMENT II—20 g. of soil were placed in an extracting apparatus (*b*, Fig. 2), and a 0.04 *N* calcium hydroxide solution allowed to percolate through. In the diagram *a* is the receptacle for the base, *e* a stopcock for regulating the flow of the base into *b*, and *c* a graduated receiver connected with tube *d* which serves to equalize the pressure. The apparatus is a closed system and duplicate results were easily obtained. 237.2 cc. of filtrate<sup>1</sup> passed through before a pink color could be detected, with phenolphthalein as an indicator, representing a lime adsorption at this point of 23.7 T. as calcium carbonate. At the close of the experiment 537.6 cc. of filtrate had percolated through, the last 50 cc. being 0.0285 *N* base, while the soil had absorbed a total of 35.28 T. of lime as calcium carbonate. 15.82 T. of lime were washed out by the first 700 cc. of distilled water, the end fraction passing through 0.00242 *N* alkali. 19.46 tons of lime were still left in the soil.

The details are given in Table VIII, in which A and B are duplicate determinations.

<sup>1</sup> Figures given are average of results A and B below.

TABLE VIII—AMOUNT OF LIME ABSORBED BY ACID SOIL FROM SOLUTION OF CONSTANT STRENGTH PERCOLATING THROUGH THE SOIL

A			
Ca(OH) <sub>2</sub>			
Percolate Cc.	Calculated as		Calculated as
	T. CaCO <sub>3</sub> Absorbed	Per cent Absorbed	T. CaCO <sub>3</sub> in Percolate
236.5	23.65	100.0	0.00
27.0	2.50	92.6	0.20
28.5	1.95	68.4	0.90
45.0	1.97	43.7	2.53
51.4	1.61	31.3	3.53
48.6	0.93	19.1	3.93
50.0	1.04	20.8	3.96
50.5	1.45	28.7	3.60
TOTAL 537.5	35.10		
B			
238.0	23.80	100.0	0.00
43.2	4.17	96.6	0.15
58.0	3.04	52.2	2.76
50.5	1.24	24.5	3.81
50.0	1.08	20.2	3.92
50.0	1.15	23.0	3.85
50.0	0.99	19.8	4.01
TOTAL 539.7	35.47		

At the completion of the experiment water was added and the first 700 cc. carried through the equivalent of 16 tons of lime as CaCO<sub>3</sub>, or nearly half the amount absorbed.

EXPERIMENT III—Twenty gram samples of yellow-gray silt loam were shaken for 3 hrs. with 200 cc. of 0.04 *N* calcium hydroxide and potassium hydroxide, respectively. Since the solution containing the potassium hydroxide would not settle, 25 cc. of normal potassium nitrate were added to both the calcium and potassium hydroxide solutions, and filtered. Titrations of 100 cc. of filtrate with 0.04 *N* hydrochloric acid gave the results included in Table IX.

TABLE IX—AMOUNT OF BASE NOT ABSORBED BY AN ACID SOIL FROM SOLUTIONS OF EQUIVALENT STRENGTH

BASE USED	0.04 <i>N</i> HCl Required to
	Neutralize Filtrate
	Cc.
Ca(OH) <sub>2</sub> .....	7.7
KOH.....	31.9

As the potassium hydroxide solution was neutralized, a copious precipitate of aluminum hydroxide was formed. No precipitate was noted upon neutralizing the calcium hydroxide solution.

It would appear from this experiment that the soil has a greater absorption power for calcium than for potassium, which is not indicated by other experiments. A chemical difference in the action of the two bases seems the more simple explanation. Potassium aluminate is soluble while calcium aluminate is not. Both are unstable except in the presence of a base. Since the potassium aluminate passes into solution it is titrated above while the calcium aluminate is precipitated around the soil particles.

This apparently throws doubt upon the magnitude of the colloidal adsorption effects which may be assumed from Expts. I and II above. The probable cause would seem to be precipitation effects. Hydrolysis will account for the rapid washing out of the lime when water is added in Expt. II.

#### EXCHANGE OF BASE

There is considerable doubt whether, when an acid soil is shaken up with a neutral salt, there is a complete exchange of base. Rice<sup>1</sup> comes to the conclusion that there is an equivalent exchange and that the acidity is due to the aluminum salts. He further claims that the ordinary methods of analysis are too crude to determine this accurately. Sharp and Hoagland<sup>2</sup> by use of the hydrogen electrode show that soil acidity is due to an excess of hydrogen ions, and that the acidity is increased by the presence of certain neutral salts.

Analysis was made of the potassium nitrate extract of yellow-gray silt loam with results shown in Table X.

TABLE X—ANALYSIS OF POTASSIUM NITRATE EXTRACT OF AN ACID SOIL  
627 Cc. of 0.04 *N* Acid =

	Gram
SiO <sub>2</sub> .....	0.04741
P <sub>2</sub> O <sub>5</sub> .....	0.00576
Al <sub>2</sub> O <sub>3</sub> .....	0.38822
Fe <sub>2</sub> O <sub>3</sub> .....	Trace
CaO.....	0.06025
Mn <sub>2</sub> O <sub>4</sub> .....	0.04839
MgO.....	0.19901

The acid combined with the alumina would be equivalent to 570 cc. of 0.04 *N* acid leaving an excess of 57 cc. to be accounted for in other ways.

Since, as has been shown by Blum,<sup>3</sup> alumina is completely precipitated before the hydrogen-ion concentration drops to a value of 10<sup>-7</sup> and, conversely, alumina will not pass into solution until the hydrogen-ion concentration reaches a value higher than 10<sup>-7</sup>, it is reasonable to conclude that there must be some absorption of base before the alumina will pass into solution. If this is true we must assume that the dissolution of alumina is a secondary reaction, and the above analysis certainly points in this direction.

It was noted that strongly acid extracts of this soil were highly colored with iron. To test the question of why iron is not also taken out in larger quantities

<sup>1</sup> *Loc. cit.*

<sup>2</sup> *J. Agr. Res.*, [3] 7 (1916), 124.

<sup>3</sup> *J. Am. Chem. Soc.*, 7 (1916), 1282.

by a similar secondary reaction, 100 g. samples of yellow-gray silt loam were shaken with 250 cc. of 0.04 N acids and a partial analysis made of 125 cc. of the filtered extracts. The results are given in Table XI.

TABLE XI—PARTIAL ANALYSIS OF WEAKLY ACID EXTRACTS OF AN ACID SOIL

ACID USED	Al <sub>2</sub> O <sub>3</sub> Gram	Fe <sub>2</sub> O <sub>3</sub>
Acetic.....	0.00383	Trace
Nitric.....	0.06913	Trace
Hydrochloric.....	0.07049	Trace

The solutions were still acid and upon neutralization white precipitates of aluminum hydroxide were formed in the hydrochloric and nitric acid extracts but none was noted in the acetic acid extract until it was neutralized and boiled. It would seem that when dilute acids are allowed to act upon an acid soil alumina is first brought into solution, and that neutral salts, when brought into contact with an acid soil, show the properties of a weak acid in this respect.

#### DIALYSIS

Normal potassium nitrate solution was shaken with yellow-gray silt loam and allowed to settle. The supernatant liquid was drawn off into a collodion bottle and subjected to dialysis with the results given in Table XII.

TABLE XII—DIALYSIS OF A NEUTRAL SALT IN CONTACT WITH AN ACID SOIL

	0.04 N KOH to Neutralize Cc.
1st water fraction.....	35.1
2nd water fraction.....	12.06
3rd water fraction.....	24.9
Left in flask.....	24.9
TOTAL.....	96.96

74 per cent of the titratable acid had passed through the membrane. As the liquid left in the dialyzing flask was being titrated a heavy precipitate formed, while that which passed through remained clear upon neutralization. It was evident that the acid passed through while the aluminum hydroxide did not. This, however, was to be expected, as this is one of the recognized methods for the preparation of colloidal aluminum hydroxide.<sup>1</sup>

#### DISTILLATION OF SOIL EXTRACT

Attempts were made to remove acid from potassium nitrate and chloride extracts of soil by prolonged distillation with steam but without success. Better success followed the distillation of the potassium

<sup>1</sup> Graham, *Ann.*, **121** (1866), 41.

acetate extract of the yellow-gray silt loam as shown in Table XIII.

TABLE XIII—DISTILLATION OF A POTASSIUM ACETATE EXTRACT OF AN ACID SOIL, AND OF STOCK SOLUTION OF POTASSIUM ACETATE (*Acidity in Terms of 0.04 N Base*)

Potassium Acetate Extract		Potassium Acetate Stock Solution	
Distillate	Residue	Distillate	Residue
72.9 Cc.	21.9 Cc.	8.6 Cc.	1.95 Cc.

Phenolphthalein was used as an indicator. This experiment shows the presence of appreciable quantities of acetic acid in the soil extract. About three-fourths of the acid shown by the extract was distilled over.

Walter Crum<sup>1</sup> prepared colloidal aluminum hydroxide by separating the acetic acid by heating, but as there were only traces of aluminum salts carried by the potassium acetate extract<sup>2</sup> it can hardly be conceived that the phenomena may be accounted for by the presence of these salts, but rather that there is an excess of acid.

#### COMPARISON OF CATION AND ANION ABSORPTION

To compare the cation and anion absorption of the yellow-gray silt loam from neutral salt solution a 0.0358 *N* solution of calcium chloride was allowed to percolate through 20 g. of the soil in the apparatus shown in Fig. 2. The extract was analyzed for calcium and chlorine. The calcium was determined in an aliquot portion of the extract which had been freed from iron and aluminum by first precipitating as the oxalate and titrating the precipitate with a standard potassium permanganate in the presence of dilute sulfuric acid. The chlorine was determined by the Volhard method<sup>3</sup> using 0.04 *N* solutions. The results are tabulated in Table XIV.

TABLE XIV—ANALYSIS OF FRACTIONS OF EXTRACT OF AN ACID SOIL BY A NEUTRAL SALT SOLUTION TO DETERMINE CATION AND ANION ABSORPTION

Extract Fractions Cc.	Calcium Normality	Chlorine Normality	Acid Normality
1—50	0.0180	0.0348	0.0046
2—50	0.0314	0.0358	0.0037
3—50	0.0332	0.0358	0.0028
4—50	0.0335	0.0358	0.0022

The cation is absorbed to a measurable extent, for which the change in acidity fails to account. There must, therefore, have been an exchange of base. This confirms the fact that there is a basic exchange regardless of the neutral salt used. (See analysis of

<sup>1</sup> *Ann.*, **89** (1854), 168.

<sup>2</sup> Compare Conner, *THIS JOURNAL*, **8** (1916), 35.

<sup>3</sup> *Ann.*, **190**, 1.

potassium nitrate extract.) The anion is absorbed little or not at all. The slight absorption shown in the first 50 cc. of extract is probably due to the wetting of the particles and to a slight dilution of the extract by moisture in the air-dried soil. A small amount of precipitate was formed in each case upon neutralizing the extract.

#### SUMMARY

1—When normal solutions of potassium nitrate, potassium chloride, sodium nitrate, sodium chloride, and calcium chloride were percolated through an acid soil all gave the same end titrations, using phenolphthalein as an indicator. This corroborates Hopkins' statements.

2—The acidity of the salt extract of an acid soil is independent of the temperature within the range from 25° to 90° C.

3—The precipitate formed in titrating the soil extract obtained by the Hopkins method absorbs the indicator to a marked extent. The end result depends upon the temperature, time, and amount of indicator used.

4—The acidity of the first portions of the neutral salt extracts of an acid soil increases with increase in concentration of the neutral salts.

5—The difference in absorption of calcium and potassium from solutions of their bases by an acid soil may be accounted for by precipitation effects.

6—There is a marked basic exchange when a neutral salt solution is added to an acid soil, by which alumina is carried into solution. This, however, does not account for the total acidity of the solution.

7—When acid soil is extracted with potassium acetate solution, a portion of acetic acid may be distilled off from the extract, showing the presence of free acid.

8—Exchange of acid radicals when an acid soil is treated with a neutral salt solution was not noted.



## ACIDITY AND ACIDIMETRY OF SOILS.<sup>1</sup> II—INVESTIGATION OF ACID SOILS BY MEANS OF THE HYDROGEN ELECTRODE

By Henry G. Knight

OKLAHOMA AGRICULTURAL AND MECHANICAL COLLEGE, STILLWATER,  
OKLAHOMA

Received October 14, 1919

### INTRODUCTION

Although the literature upon the subject of soil acidity is voluminous, the use of the hydrogen electrode in soil investigations has been rather limited.

Gillespie<sup>2</sup> made use of the hydrogen electrode for determining the hydrogen ion concentration of a mixture of soil with pure water; but, for reasons which will develop in the investigations given herewith, the presence of a conducting medium was found to be desirable. Sharp and Hoagland<sup>3</sup> studied the hydrogen concentrations of suspensions of soils in pure water under various conditions, effects of natural salts and bases upon hydrogen ion concentrations of soil suspensions, and made titrations with various bases.

The purpose of the present investigation is to study: (1) the speed of reactions between neutral salt solutions and soils; (2) the speed of reactions in the presence of a base; (3) the change in hydrogen ion concentration with change of amount of base and with time, and the change in conductivity of soil solutions.

### APPARATUS

Preliminary experiments were conducted with an apparatus similar to that described by Hildebrand,<sup>4</sup> and some experiments described elsewhere with soil solutions were carried out, but for use with solutions in contact with the soil it was found to be rather unsatisfactory. For all work reported, unless otherwise stated, a high-grade potentiometer (Leeds and Northrup, No. 28952) was used with a gas cell especially designed for the work.

**GAS CELL**—Preliminary experiments showed that for

<sup>1</sup> This is a thesis submitted to the faculty of the University of Illinois in partial fulfillment of the requirements for the degree of Doctor of Philosophy. Acknowledgment is made of many helpful suggestions and criticisms received from Prof. C. G. Hopkins and H. A. Noyes.

<sup>2</sup> *J. Wash. Acad. Sci.*, **6** (1916), 7.

<sup>3</sup> *J. Agr. Res.*, **7** (1916), 124.

<sup>4</sup> *J. Am. Chem. Soc.*, **35** (1913), 847.

uniform results it was necessary to have a gas cell which could be agitated continuously, as apparently the agitation produced by the entering gas was not sufficient. After a number of trials the gas cell shown in Fig. 1 was designed for this work. It is cylindrical in shape, 3.3 cm. in diameter and 16 cm. in length,

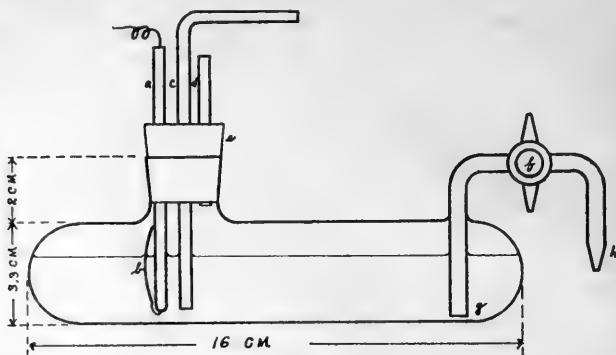

FIG. 1

the ends being rounded off. At one end an opening is provided of a size to carry a No. 4 rubber stopper, through which pass the electrical connection *a* to the platinum plate *b* to serve as the hydrogen electrode, the tube *c* for the ingress of hydrogen gas, and tube *d* for the outlet. Tubes *c* and *d* have capillary tubes sealed into the ends to regulate the flow of hydrogen. To make connections with the calomel half cell a glass tube, *g*, is provided at the further end of the gas cell provided with a stopcock, *f*, and a constricted tip, *h*. This tube reaches to within a few mm. of the bottom of the gas cell and as it did not readily clog with soil was found to be very satisfactory. The gas cell was designed to be of 100 cc. capacity and to be filled half full of liquid, leaving room for 50 cc. of gas. The reason for this arrangement will develop later.

The hydrogen electrode *b* is a rectangular piece of sheet platinum, 1.2 x 2.4 cm., with pieces of platinum wire welded to each end, and is similar to that used by Gillespie.<sup>1</sup> The wires were welded into the glass tube at each extremity as shown, making connections with the mercury in the tube and at the same time supporting the electrode rigidly.

Fig. 2 shows diagrammatically the method of agitating the cell and connections as measurements were being made. *a* is the calomel electrode provided with a stop-

<sup>1</sup> *Loc cit*

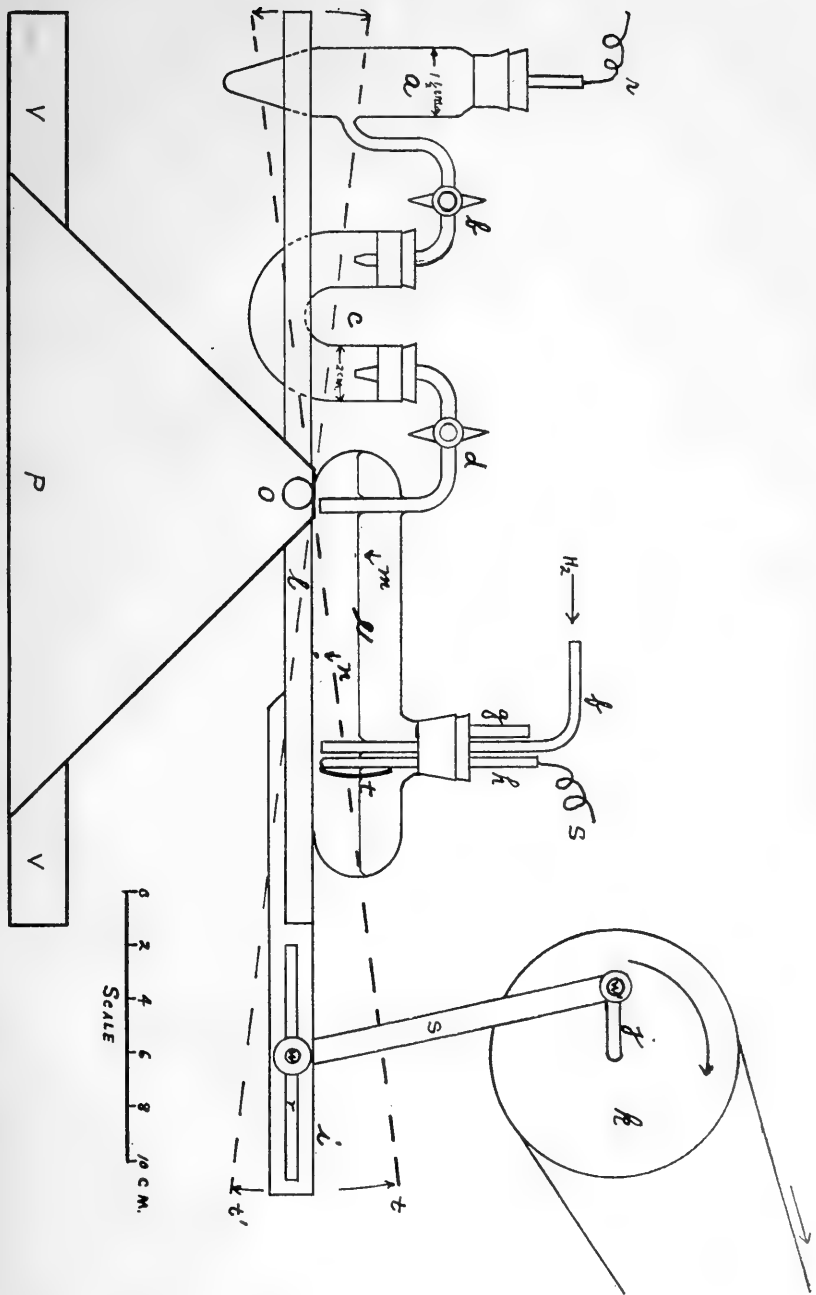

FIG. 2.

cock, *b*, and *c* is a U-tube filled with normal potassium chloride, making connection with the hydrogen gas cell by the tube *d*. The apparatus was placed upon a tilting table hinged at the point *o* to the base *P*. The table is rocked by means of the adjustable arm *s* and crank *j* attached by suitable gears and pulleys to a constant source of power. In building up the shaking apparatus free use was made of the parts of one of the popular metal construction shapes to teach children to make their own toys.

It was found by experiment that by giving the table 72 complete oscillations per minute through a total angle of  $6^{\circ}$  to  $7^{\circ}$  the liquid in the gas cell was thoroughly agitated; that the rubber stopper was not wetted, but that the soil was kept thoroughly mixed with the solution while the coarser particles of sand in the soil would tend to collect in a nodal point *n* in the bottom of the cell near the center. At this speed the hydrogen bubbles rose to about the point *m* before they broke, causing the cell to be quickly freed of air. Except for very light peat soils there was no tendency for the soil to ascend into the tube *d*.

The arrangement of the different parts of the apparatus as used in making measurements is shown diagrammatically in Fig. 3. The apparatus is designed to carry two gas cells, marked E. M. F., so that duplicate measurements may be made without changing cells.

The use of the U-tube for making connections between the gas cells and calomel electrode was found to be a most satisfactory arrangement. The resistance of the chain is slightly increased, but diffusion is markedly reduced. During several weeks of continuous use, the calomel electrode changed less than 0.0005 volt. The gas cell is claimed to have the following advantages:

(1) large capacity, (2) absence of dead air space, (3) ease of cleaning, (4) all-glass contact with liquid, (5) freedom from clogging, (6) ease of manipulation, (7) adaptability to thorough agitation, (8) minimum possibility of diffusion.

**CALOMEL ELECTRODE**—Calomel was prepared by treating pure mercury with dilute nitric acid, precipitating with hydrochloric acid, washing twenty times with potassium chloride, and finally shaking with normal potassium chloride and pure mercury, as recommended by Ellis<sup>1</sup> for obtaining an electrode of constant potential. The electrodes were prepared with this gray mixture of mercury, calomel, and normal

potassium chloride by first putting into the bottom of the carefully cleaned electrode cell a small amount of pure mercury to cover the platinum connection. No difficulty was experienced in getting electrodes to check within 0.0005 volt. The stopcock upon the tube leading from the calomel electrode was well greased and was opened only when readings were being taken. Connection was made to the U-tube *c* (Fig. 2) through a rubber stopper well driven home, making this side of the system practically gastight.

**HYDROGEN ELECTRODE**—The platinum electrode was prepared by plating as a cathode in a one per cent solution of platinum chloride, containing a small amount (about 0.05 per cent) of lead acetate to cause the platinum black to adhere. Attempts were made to use a solution of pure platinic chloride as recommended by Ellis, but this proved unsatisfactory as the platinum black invariably washed off within a few minutes after being placed in the cell.

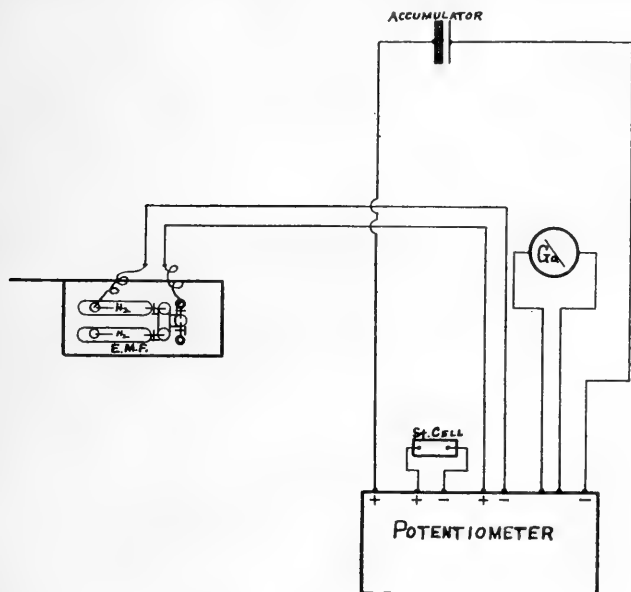

FIG. 3

In plating a platinum anode was used. The strength of the current was varied from time to time but no variation in the potentials of the electrode or in the time required to become saturated was noted from this cause. If the evolution of hydrogen was too lively some of the platinum black was loosened. The plating was continued from 1 to 2 hrs., or until a good heavy

deposit of platinum black was formed. The electrodes were placed in distilled water and given a final wash just before using.

**HYDROGEN GENERATOR**—Hydrogen was prepared electrolytically as needed, using potassium hydroxide and nickel electrodes, as shown in Fig. 4. Two salt-mouth bottles, *G* and *G'*, were used. *E* and *E'* are the nickel electrodes, *M* and *M'* are glass partitions running almost to the bottom of the cells to reduce diffusion as much as possible. *P* and *P'* are safety valves made of test-tubes. The outlets *O* and *O'* were closed while hydrogen was being taken off. By using two cells in parallel and electrolyzing with a current of 10 amperes, about 150 cc. of hydrogen per minute were obtained. The usual general precautions were taken in washing and purifying the gas.

#### PROCEDURE

To fill the tube *g* of the gas cell (Fig. 1) the cell was partly filled with liquid, a stopper inserted in the opening *e*, and pressure exerted, so that, when the stopcock *f* was opened, the liquid would fill the tube *g* and flow out at *h*. Care was taken to thoroughly wet the stopcock *f* by loosening and turning. All measurements were made with this stopcock closed.

After the gas cell was filled with soil and solution and placed as shown in Fig. 2 the table was oscillated and hydrogen run in at *f* for 4 or 5 min.; the tube *g* was closed and rocking continued for 4 min.; hydrogen was again run in for 4 min. to drive out the last traces of air; *g* was again closed, the stopcock *b* opened, and readings were taken immediately.

The procedure varied somewhat with the number of readings to be taken, type of experiment, etc. If readings were to cover a period of half an hour or more, after the first large volume of hydrogen was run in, it was found advisable to allow a small amount to bubble through to overcome any diffusion which might take place through the rubber connections.

#### DESCRIPTION OF SOILS INVESTIGATED

*Yellow-Gray Silt Loam, Sample No. 1*—Anacidsub soil collected from the southern part of the state of Illinois. This soil gave a lime requirement by the Hopkins method<sup>1</sup> of 4.2 tons and by the Veitch method<sup>2</sup> 5.6

<sup>1</sup> U. S. Dept. of Agr., Bureau of Chem., *Bulletin* 107 Revised (1908), 20.

<sup>2</sup> *J. Am. Chem. Soc.*, 24 (1902), 1120.

tons calculated as calcium carbonate.<sup>1</sup> No carbonates were present as determined by the Marr<sup>2</sup> method.

*Black Peaty Loam, Sample No. 1-281*<sup>3</sup>—Collected by C. G. Hopkins near Bolton, N. C. Limestone requirement by the Hopkins method was 3.445 tons.

*Black Clay Loam, Sample No. 1-284*—Collected by C. G. Hopkins near Bolton and Byrdsville. Some leaf mold was present. Limestone requirement by the Hopkins method was 4.982 tons.

*Peat, Sample No. 1-241*—Labeled deep peat or muck, collected near Titusville, Florida, by C. G. Hopkins. Limestone required by the Hopkins method was 3.267 tons.

*Black Muck, Sample No. 1-242*—Collected from Wauchula, Florida, collected by C. G. Hopkins. Limestone requirement by the Hopkins method was 4.056 tons.

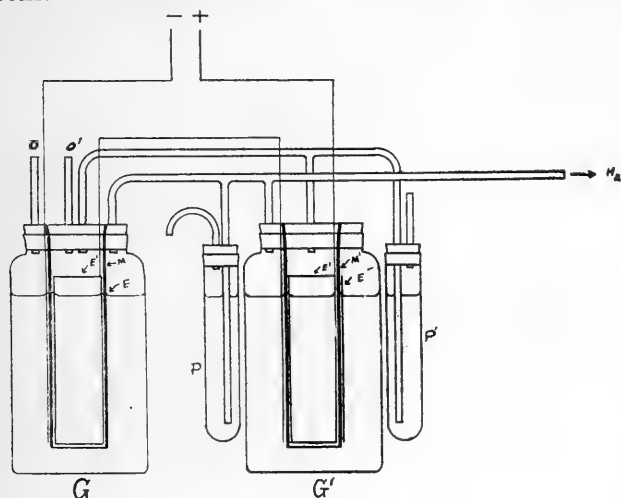

FIG. 4

*Yellow Silt Clay, Sample No. 2660*—Collected from Clay County, Illinois. A silty clay, stiff and plastic. Subsoil sample. Limestone required by the Hopkins method was 5.08 tons.

*Gray Clayey Silt, Sample No. 2968*—Collected from Jackson County, Illinois. A compact, impervious subsoil containing iron blotches and concretions. Limestone required by the Hopkins method was 7.92 tons.

<sup>1</sup> All figures are based upon an acre of soil 6 $\frac{2}{3}$  in. in depth, calculated to weigh 2,000,000 lbs., except peats which are calculated to weigh 1,000,000 lbs.

<sup>2</sup> *J. Agr. Sci.*, [II], 3, 155.

<sup>3</sup> Numbers refer to the University of Illinois Soil Survey Numbers.

*Gray Plastic Clay, Sample No. 3957*—Collected from Winebago County, Illinois. A subsoil sample containing clayey sand. Limestone required by the Hopkins method was 2.6 tons.

*Yellow Plastic Clayey Silt, Sample No. 3556*—Collected from Clay County, Illinois. A subsoil sample. Limestone required by the Hopkins method was 4.67 tons.

*Yellow Silt Loam, Sample No. 4068*—Collected from La Salle County, Illinois. This was subsurface sample having a lime requirement by the Hopkins method of 2.89 tons.

*Brown Sandy Loam, Sample No. 6316*—This was subsurface sample having a limestone requirement by the Hopkins method of 1.65 tons.

#### EXPERIMENTAL

EXPERIMENT I. SPEED OF REACTION BETWEEN AN ACID SOIL AND A NEUTRAL SALT—This experiment was planned to observe the speed of change in hydrogen ion concentration of a neutral salt solution when shaken together with an acid soil.

The gas cell was filled with 50 cc. of 0.5 N salt solution and after the potential had become constant, which was usually within 10 min., 5 g. of soil (2.5 g. in the case of peat soil) were quickly introduced and readings were taken at stated intervals.

TABLE I—SPEED OF REACTION BETWEEN ACID SOIL AND A NEUTRAL SALT SOLUTION

(Readings are given in volts. Temperature 25° C.)

TIME MIN.	Yellow-Gray Silt Loam			Brown Sandy Loam	Yellow Plastic Clayey Silt	Peat
	0.5 N KCl	1/4 Mol. CaCl <sub>2</sub>	0.5 N KC <sub>2</sub> H <sub>3</sub> O <sub>2</sub>	0.5 N KCl	0.5 N KCl	0.5 N KCl
0	0.6969	0.6823	0.7295	0.6966	0.6967	0.6967
5	0.4843	0.4947	0.6715	0.5658	0.4944	0.5706
10	0.4843	0.4950	0.6707	0.5660	0.4944	0.5691
15	0.4848	0.4950	0.6706	0.5660	0.4944	0.5687
20	0.4854	0.4950	....	....	0.4944	0.5687
25	0.4860	....	0.6693	....	0.4946	0.5688
30	0.4865	0.4950	....	0.5660	0.4946	0.5690
40	0.4871	....	0.6693	....	0.4950	0.5692
60	0.4878	0.4957	0.6693	0.5664	....	0.5696
90	0.4890	0.4963	....	....	....	....
120	0.4895	....	....	0.5670	0.4969	....
180	0.4895	0.4972	0.6688	....	0.4984	....
240	....	....	....	....	0.5010	....
	0.4963 <sup>1</sup>	....	....	0.5733 <sup>2</sup>	0.5063 <sup>3</sup>	....

<sup>1</sup> After 24 hrs.    <sup>2</sup> After 48 hrs.    <sup>3</sup> After 12 hrs.

Under the conditions of the experiment a voltage of 0.6967 represents a hydrogen ion concentration of  $10^{-7}$  or true neutrality. Voltages less than this figure show a higher hydrogen ion concentration or a condition of acidity while figures above show a hydrogen ion concentration of less than  $10^{-7}$  or an alkaline condition.



In Table I it will be noted that the lowest readings were obtained within 5 min. in all cases but two, the yellow-gray silt loam with potassium acetate, and peat with potassium chloride. The potassium acetate solution showed a marked alkalinity before the soil was added, therefore we should expect it to act more as a base. It will be discussed in connection with the next experiment. The peat did not wet readily which may account for its behavior. After the low readings were obtained there was a gradual increase in the voltages, corresponding to a decrease in the hydrogen ion concentration.

It is evident that the main reaction between the salt solution and the soil reaches an equilibrium very quickly. Secondary reactions are indicated by an increase in voltage after a lapse of time, except in the case where potassium acetate was used, where secondary reactions are not apparent to any great extent. Secondary reactions of greater or less magnitude should be expected when the hydrogen ion concentration rises appreciably above  $10^{-7}$ . Reduction of nitrates<sup>1</sup> may be put forward as an explanation but this is immediately questioned since there is no evidence of the potassium acetate mixture showing a change toward alkalinity.

EXPERIMENT II. SPEED OF REACTION IN THE PRESENCE OF A BASE—This experiment was similar to Expt. I. 50 cc. of 0.5 *N* potassium chloride solution containing given quantities of calcium hydroxide, calculated as calcium carbonate, were used, as indicated in Table II. Five grams of soil were used except in the case of peat, when 2.5 g. were used.

TABLE II—SPEED OF REACTION BETWEEN SOIL AND SALT SOLUTION IN PRESENCE OF BASE

TIME MIN.	Brown Sandy Loam	Yellow-Gray Silt Loam		Yellow Plastic Clayey Silt	Peat
	2 T. CaCO <sub>3</sub>	4 T. CaCO <sub>3</sub>	10 T. CaCO <sub>3</sub>	5 T. CaCO <sub>3</sub>	10 T. CaCO <sub>3</sub>
0.....	0.9543	0.9715	0.9961	0.9803	0.9961
5.....	0.7783	0.7483	0.8505	0.6562	0.8345
10.....	0.7565	0.6923	0.8410	0.6302	0.7642
15.....	0.7440	0.6467	0.8363	0.6228	0.7370
20.....	0.7313	0.6161	0.8356	0.6199	0.7173
25.....	0.7269	0.6037	0.8337	0.6170	0.7053
30.....	0.7232	0.5978	0.8326	0.6148	0.6951
40.....	0.7165	0.5935	0.8298	0.6111	0.6809
60.....	0.7113	0.5897	0.8273	0.6072	0.6672
90.....	.....	0.5855	0.8262	.....	.....
120.....	0.7066	.....	.....	0.5987	0.6499
180.....	.....	0.5820	0.8206	0.5951	0.6432
	0.7022 <sup>1</sup>	.....	0.8186 <sup>2</sup>	0.5933 <sup>3</sup>	0.6394 <sup>3</sup>

<sup>1</sup> After 48 hrs.    <sup>2</sup> After 5 hrs.    <sup>3</sup> After 4 hrs.

<sup>1</sup> An attempt was made to use potassium nitrate but it was noted that even in a neutral solution reduction of the nitrate to ammonia took place to an extent which could be noted with organic indicators.

The change in the hydrogen ion concentration was very rapid at first, but continually rose as long as the experiments were conducted. The plotted curves are all similar in character and of the general type shown in Fig. 5, which is for the yellow-gray silt loam with four tons of lime.

Although equilibrium is not reached for a considerable period under the conditions of the experiment, the greater portion of the reaction takes place within a few minutes. After the neutral point is reached the hydrogen ion concentration continues to increase at the same relative rate without change. This phenomenon explains the condition noted by MacIntire<sup>1</sup> who distinguishes between immediate and continued lime requirement and Truog<sup>2</sup> who makes the division into active and latent soil acidity. Both investigators added an excess of lime to the soil while in certain of the above experiments the lime requirements were not satisfied. Apparently the reaction is in each case an equilibrium reaction. Such being the case, any division as indicated by them is an arbitrary one, and the results will not necessarily bear any relation to the total lime requirements.

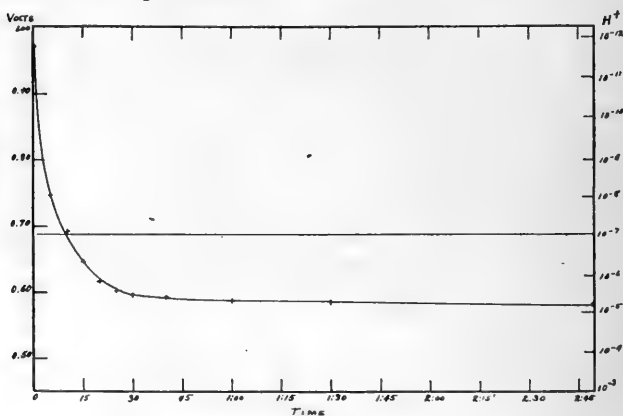

FIG. 5

It would seem from an inspection of the curve that the relation may be expressed empirically by the equation

$$\frac{dx}{dt} = K(A-x),$$

in which  $x$  is the hydrogen ion concentration with time  $t$ ,  $A$  the total change in hydrogen ion concentra-

<sup>1</sup> Tenn. Expt. Sta., *Bulletin* 107 (1914), 193.

<sup>2</sup> *THIS JOURNAL*, 8 (1916), 341.

tion, and  $K$  a characteristic constant for the system under consideration. It would appear that the longer the interval chosen the more nearly would the results approach the maximum lime absorption, provided side reactions are not considered. It is quite probable that under field conditions the reactions will be far slower than the above experiment would indicate. The conditions in the field are often such that reactions cannot take place rapidly, while the converse is true in the laboratory. In this experiment a salt solution was used with calcium hydroxide, a condition, certainly, where reaction may take place with utmost speed.

This experiment would seem to throw some light upon the action of soil with potassium acetate in Expt. I. Potassium acetate is basic in character and even at the end of 180 hrs. the mixture with an acid soil contained only a slight excess of hydrogen ions.

EXPERIMENT III. STUDY OF CHANGE IN HYDROGEN ION CONCENTRATION OF NEUTRAL SALT SOLUTION CONTAINING VARYING AMOUNTS OF BASE—50 cc. of a 0.5  $N$  neutral salt solution containing the desired amount of base were placed in the gas cell and readings were taken at the end of 20 min. The gas cell was rocked continuously as in the former experiments.

In the light of Expt. II, it can be readily understood that duplicates are somewhat difficult to obtain unless the manipulation is the same, and the time element eliminated. The speed of the reaction should depend somewhat upon the base used and the neutral salt with which it is combined. Considering these facts it is rather remarkable that the results obtained as shown in Table III should be of the same order. The experiments were all conducted upon yellow-gray silt loam.

The salt solutions in contact with the soil (Series 0.0 T.  $\text{CaCO}_3$ ) in Table III show considerable difference in potential, but all show about the same neutral point, *i. e.*, 5.0 T.  $\text{CaCO}_3$ . From this point the variation in the readings becomes rather wide in both directions.

The general form of the curves is shown by the type curve, Fig. 6. Two points regarding this curve may be discussed. It will be noted that the curve in the slope inclines more toward the vertical as the neutral point is reached and after this point is passed the slope inclines away from the vertical, approaching the slope at the lower end of the curve.

TABLE III—STUDY OF CHANGE IN HYDROGEN ION CONCENTRATION OF A NEUTRAL SALT SOLUTION TO WHICH VARIOUS AMOUNTS OF BASE HAVE BEEN ADDED WHEN PLACED IN CONTACT WITH SOIL

(Results given in volts. Soil is yellow-gray silt loam. 5 g. were taken in each case)

Base Equivalent to T. CaCO <sub>3</sub>	0.5 N		0.5 N		0.5 N	
	KCl + Ca(OH) <sub>2</sub>	NaCl + Ca(OH) <sub>2</sub>	CaCl <sub>2</sub> + Ca(OH) <sub>2</sub>	K <sub>2</sub> SO <sub>4</sub> + Ca(OH) <sub>2</sub>	KCl + KOH	
0.0	0.4843	0.4995	0.4966	0.5245	0.4843	
1.0	0.5099	0.5118	0.5105	0.5345	0.5119	
2.0	0.5247	0.5180	0.5259	0.5527	0.5269	
3.0	0.5428	0.5575	0.5475	0.5679	0.5505	
4.0	0.6019	0.6125	0.6215	0.6169	0.6136	
4.2	0.6187	....	....	....	....	
4.4	0.6342	....	....	....	....	
4.6	0.6405	....	....	....	....	
4.8	0.6651	....	....	....	....	
5.0	0.6868	0.6890	0.6894	0.6700	0.6888	
5.2	0.6943	....	....	....	....	
5.4	0.7059	....	....	....	....	
5.6	0.7211	....	....	....	....	
5.8	0.7232	....	....	....	....	
6.0	0.7387	0.7414	0.7070	0.7330	0.7391	
7.0	0.7726	....	....	....	0.7743	
8.0	0.7942	....	....	....	....	
10.0	0.8529	0.8335	0.7990	0.8443	0.8819	

There is no abrupt change in hydrogen ion concentration, as was noted by Hildebrand,<sup>1</sup> when a strong acid is neutralized by a base, but rather the curve approaches a straight line, *i. e.*, for each addition of base

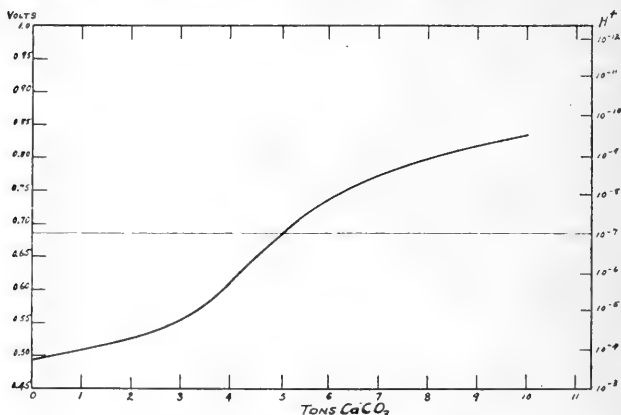

FIG. 6

there is a corresponding nearly equal change in hydrogen ion concentration. One may represent the change in the hydrogen ion concentration by the equation

$$\log C = KB + K_1$$

where C is the hydrogen ion concentration, B the base added, and K and K<sub>1</sub> characteristic constants.

The systems investigated above have all the characteristics of mixtures with a high reserve acidity,<sup>2</sup> *i. e.*, the hydrogen ion concentration suffers very little change with comparatively large additions of base.

<sup>1</sup> *Loc. cit.*

<sup>2</sup> Washburn *J. Am. Chem. Soc.*, **30** (1908), 37.

This would be expected if the acid is comparatively insoluble.

Referring again to Table III it will be noted that after the neutral point is reached the hydrogen ion concentration for the system  $\text{CaCl}_2 + \text{Ca}(\text{OH})_2 + \text{Soil}$  shows a higher hydrogen concentration than the system  $\text{KCl} + \text{KOH} + \text{Soil}$  for the same equivalents of base. This may be accounted for by the precipitating action of calcium hydroxide. The difference in conductivity adds weight to this view.

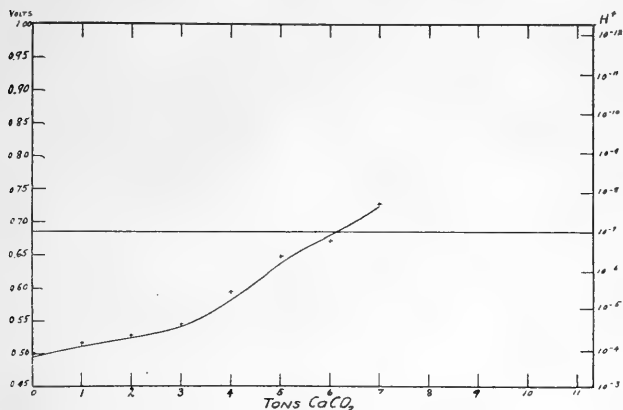

FIG. 7

When the base is allowed to act for a longer period of time there is in general a depression of the whole curve toward the acid side as is shown by Table IV and Fig. 7 which is the graph of the system 0.5 N KCl +  $\text{Ca}(\text{OH})_2 + \text{Soil}$ .

TABLE IV—EFFECT OF TIME UPON ABSORPTION OF BASE  
(Soil used was yellow-gray silt loam. Time, 3 hrs. Results recorded in volts)

T. $\text{CaCO}_3$	0.5 N KCl + $\text{Ca}(\text{OH})_2$	0.5 N KCl + KOH
0.0	0.4963	0.4997
1.0	0.5120	0.5157
2.0	0.5249	0.5276
3.0	0.5418	0.5445
4.0	0.5820	0.5959
5.0	0.6397	0.6488
6.0	0.6797	0.6702
7.0	0.7217	0.7268

It will be noted that for the same amount of base there is a higher hydrogen ion concentration than shown in Table III. Hydrogen ion concentration increases with time in the presence of a soluble base.

To compare the change of the hydrogen ion concentration of solutions in contact with different soils, a number of soils were chosen and similar determina-

tions made as with the yellow-gray silt loam in Table IV. All the soils were shaken for 3 hrs. with 50 cc. of 0.5 *N* potassium chloride solution containing the required amount of lime. In each case 5 g. of soil were used, except in the case of the peat soils, of which 2.5 g. were taken. The results are given in Table V.

Graphs of some of the above readings (Fig. 8) show nearly straight line functions. Certain of the soils tested, Nos. 1, 2, 3, 4, 6, and 11, show straight line functions for all measurements taken, while the others show more or less distinct changes in slope at two points, one being on the acid side, *i. e.*, where the  $H^+$  concentration is greater than  $10^{-7}$ , and the other on the basic side. The same is true of the yellow-gray silt loam (Fig. 7). At no point in these graphs is there an abrupt change in slope, as would be expected if we were neutralizing a strong acid, but instead the neutral point is reached at an angle depending upon the character of the soil. It requires comparatively large additions of base to produce a marked change in hydrogen ion concentration.

It may be readily understood that the organic indicators which change color at different hydrogen ion concentrations will show marked differences in the lime requirements of soils, because of the slight change in hydrogen ion concentration with the additions of lime. With the sandy loam soil a change in hydrogen ion concentration of the indicator from  $10^{-5}$  (corresponding to the color change of methyl orange) to  $10^{-8}$  (corresponding to the color change of phenolphthalein) would represent a change in the apparent lime requirement from 0.0 T. to 3 T.; and a change in the lime requirement for peat from about 1 T. to more than 20 T. of calcium carbonate. It is evident that soil solutions may be distinctly acid to litmus while alkaline to methyl orange.

The slight changes in hydrogen ion concentration with addition of base will account for the great variation in results obtained for the lime requirement of soils by the different methods proposed. The greater the slope of the curve the less will be the differences observed. With sandy soils it would be expected that the results obtained by various methods would approach each other, greater variations would be observed with other inorganic soils, while with soils high in organic matter it would be expected that the widest differences would be noted.

The time factor becomes important, as is shown in Tables I and II. The longer the base acts the higher is the hydrogen ion concentration at all initial concentrations of base. The temperature undoubtedly should receive consideration, for the speed of reaction is increased, salts are hydrolyzed to a greater extent,<sup>1</sup> and water of hydration may be decreased with increase in temperature.

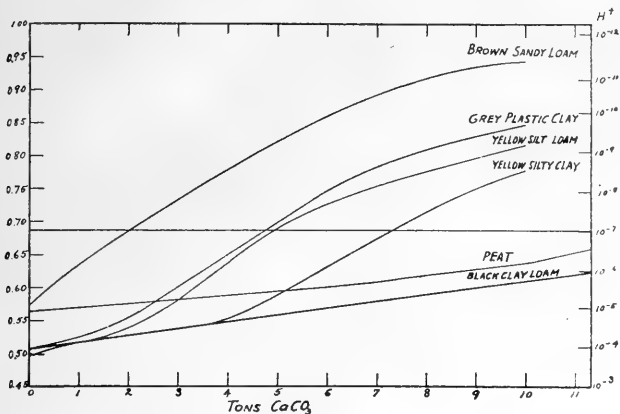

FIG. 8

We should expect that an acid soil would take up larger quantities of calcium from calcium carbonate than from calcium chloride, or sodium from sodium acetate than from sodium chloride as has been repeatedly shown to be the case. This may be explained at least partially by differences in hydrolysis of the salts and the differences in the ionization of the acid. With a carbonate as the reagent, since the point of equilibrium depends also upon the partial pressure of carbon dioxide, it may be understood that the apparent lime requirement may be changed by simply changing the partial pressure of carbon dioxide. The results reported by Ames and Schellenberger,<sup>2</sup> by the Hutchinson-MacLennan<sup>3</sup> and the vacuum methods, are in line with this argument.

The placing of the soil under artificial conditions with respect to temperature, the use of powerful reagents and the extremely finely divided material employed in most of the methods suggested will certainly affect the speed of the reaction. Furthermore, the equilibrium is without doubt a metastable one.

<sup>1</sup> Landolt and Börnstein, "Physikalisch Chemische Tabellen."

<sup>2</sup> THIS JOURNAL, 8 (1916), 243.

<sup>3</sup> Chem. News, 110 (1914), No. 2854, 61.

TABLE V—CHANGE IN HYDROGEN ION CONCENTRATION OF SALT SOLUTIONS IN CONTACT WITH SOILS  
(Results recorded in volts)

Ca(OH) <sub>2</sub> as I. CaCO <sub>3</sub>	(1) Black Peaty Loam	Black Clay Loam	Peat	(4) Black Muck	(5) Yellow Silty Clay	(6) Gray Clayey Silt	(7) Gray Plastic Clay	(8) Yellow Plastic Clayey Silt	(9) Grayish Yellow Clayey Silt	(10) Yellow Silt Loam	(11) Brown Sandy Loam
0.0	0.5290	0.5089	0.5654	0.4995	0.4979	0.4707	0.5072	0.4997	0.5034	0.4984	0.5753
1.0	0.5396	0.5171	0.5699	.....	0.5184	0.4831	0.5271	0.5065	0.5126	0.5177	0.6366
2.0	0.5487	0.5257	0.5757	.....	0.5199	0.4922	0.5526	.....	0.5227	0.5386	0.6887
3.0	0.5629	0.5352	0.5828	.....	0.5311	0.5001	0.6077	0.5275	0.5338	0.5780	0.7340
4.0	.....	0.5463	0.5705	.....	0.5485	0.5076	0.6408	.....	0.5538	0.6364	0.7796
5.0	.....	0.5571	0.5948	.....	0.5942	0.5178	0.6974	0.5719	0.5588	0.6955	0.8240
6.0	0.5953	0.5571	0.5948	0.5413	0.5942	0.5178	0.6974	0.5719	0.5588	0.6955	0.8240
7.0	.....	0.5679	0.6006	.....	0.6338	0.5206	0.7465	0.6233	0.6502	0.7297	0.8396
8.0	.....	.....	.....	.....	0.6733	.....	.....	0.6748	.....	.....	.....
9.0	.....	.....	.....	.....	0.7164	.....	.....	0.7216	.....	.....	.....
10.0	0.6391	0.6105	0.6373	0.5822	0.7770	0.5820	0.8483	0.7658	0.7737	0.8178	0.9446
15.0	0.6783	0.6470	0.6699	0.6198	.....	.....	.....	.....	.....	.....	.....
20.0	0.7267	0.7006	0.7153	0.6684	.....	.....	.....	.....	.....	.....	.....



The present researches may not be said to be free from these faults.

TABLE VI—CONDUCTIVITY OF SOIL SOLUTION CONTAINING VARIOUS QUANTITIES OF BASE, IN CONTACT WITH ACID SOIL  
(Base Calculated as Tons of CaCO<sub>3</sub> per Acre  
Results = Specific Conductivity × 10<sup>6</sup>)

Base Calc. T. CaCO	Yellow-Gray Silt Loam. Base Ca(OH) <sub>2</sub>			Yellow-Gray Silt Loam. Base KOH			Black Peaty Loam Base Ca(OH) <sub>2</sub>		
	Standing 1 Hr.	Standing 18 Hrs.	Shaken 3 Hrs.	Standing 1 Hr.	Standing 18 Hrs.	Shaken 3 Hrs.	Standing 1 Hr.	Shaken 3 Hrs.	Black Clay Loam. Base Ca(OH) <sub>2</sub> Standing 1 Hr.
0.0	1.016	1.016	0.913	1.016	1.016	0.913	2.341	2.837	3.813
1.0	1.089	1.129	0.916	1.276	1.203	1.132	2.825	3.388	4.015
2.0	1.220	1.129	0.994	1.733	1.618	...	3.050	3.720	...
3.0	1.638	1.464	1.146	2.520	2.376	1.968	3.468	4.013	4.498
4.0	1.906	1.980	1.495	3.748	3.245	2.402	3.744	4.296	...
4.4	2.033	2.120	1.691	4.637	3.748	...	...	...	...
4.8	2.226	2.248	1.826	5.100	4.122	...	...	...	...
5.2	2.226	2.276	1.980	5.864	4.620	...	...	...	...
5.6	2.346	2.365	2.048	7.318	5.352	...	...	...	...
6.0	2.480	2.352	2.074	9.300	5.978	4.888	4.140	4.767	...
7.0	3.390	2.799	2.310	14.250	8.718	...	4.440	4.968	5.408
10.0	10.170	4.842	3.427	43.580	29.330	25.420	6.055	5.457	5.820

In soils in contact with solutions we have to deal with solid phases whose reaction velocities are necessarily very slow. The substances which produce the acid phenomena when salt solutions are added to acid soils are undoubtedly only slightly soluble and the products formed may pass into similar solid phases. Even substances which are assumed to be soluble may be held in the colloidal condition. Kahlenburg and Lincoln<sup>1</sup> claim that the silicic acid of spring waters is present in the colloidal condition, and the fact that aluminum salts are hydrolyzed to a marked extent while the solubility of aluminum hydroxide is very slight may be taken as an indication that it is held in solution in part as a peptized colloid. The work of Mahin, Ingraham, and Stewart<sup>2</sup> seems to be evidence that the above statement is true in regard to the aluminates.

In anticipation of criticism from the use of neutral salt solution in the potential readings throughout these investigations the following experiment was planned.

It may be reasoned that if slightly soluble acids are present in acid soils it should be possible to measure the hydrogen ion concentration from such a water solution, if the acid ionizes at all, by means of the hydrogen electrode and other indicators. This has been done by Gillespie,<sup>3</sup> but no attempts have been made to follow the change in hydrogen ion concentra-

<sup>1</sup> *J. Phys. Chem.*, **2** (1898), 88.

<sup>2</sup> *J. Am. Chem. Soc.*, **35** (1913), 30.

<sup>3</sup> *Loc. cit.*

tion upon the addition of a base. In repeating Gillespie's experiment, using yellow-gray silt loam, it was found that after shaking 5 g. of the soil with 50 cc. of distilled water for one-half hour, the potential reading of the mixture was depressed to 0.565 volt, but there is question whether equilibrium had yet been attained considering the fact that neutral salts depress the reading to about 0.5 volt.

The above experiment was modified by using 50 cc. of distilled water containing the equivalent of 4 tons of lime calculated as calcium carbonate. After the readings had become constant 5 g. of yellow-gray silt loam were added and readings taken at stated intervals. The results are given in Table VII.

TABLE VII—CHANGE IN POTENTIAL IN AN ACID SOIL ON SHAKING WITH SOLUTION OF CALCIUM HYDROXIDE

Time Minutes	Volt
0.....	0.9723
30.....	0.7056
60.....	0.6772
90.....	0.6580
240.....	0.6529
420.....	0.6416

Equilibrium evidently had not been reached after 7 hrs. of continuous shaking. In performing the experiment some difficulty was encountered because of the high resistance of the chain, but the readings are typical. It will be noted that the reaction is much slower than in the presence of a neutral salt as may be expected from a consideration of the number of ions present in each case.

The salt solutions used throughout this research, unless otherwise stated, were 0.5 *N*, while the calcium hydroxide solution used above was 0.008 *N*, or an approximate ratio of 500 : 8 at the beginning of the reaction. While the neutral salt concentration remained practically unchanged the calcium hydroxide concentration, and consequently the hydroxyl ion concentration, became progressively less.

The above experiment brings out another fact of importance. After the base has been neutralized the hydrogen ion concentration continues to rise slowly. The substance producing the action comes to an equilibrium very slowly with water, and 6 hrs. after the lime was neutralized hydrogen ions were still being thrown into the solution.

EXPERIMENT IV. CONDUCTIVITY OF SOIL SOLUTIONS—To test the question of the insolubility of the products formed when a base is added to an acid soil,

some conductivity experiments were conducted as a preliminary investigation.

Five grams of soil were shaken with 75 cc. of distilled water containing the required amount of base and conductivity measurements made upon the recently shaken mixture of soil and solution with a plunge electrode having a constant of 0.0305. All readings were taken at  $25^{\circ} \pm 1^{\circ}$ .

From an inspection of Table VI, the following deductions may be made:

The specific conductance increases with each addition of base, but the increase is much greater with potassium hydroxide than with calcium hydroxide. The difference is far too great to be accounted for by the difference in conductivity of potassium and calcium ions.<sup>1</sup> Either the calcium salts formed are less soluble or they must ionize to a far less extent than the potassium salts. The former view is substantiated by the difference noted in the soluble base left in solution when a soil is treated with water containing an excess of base. From the standpoint of the absorption theory it may be argued that calcium hydroxide is absorbed to a greater extent than potassium hydroxide, but this theory can hardly be substantiated in face of the fact that potassium and calcium hydroxide seem to have practically equivalent power to neutralize the acid of the soil noted elsewhere in this paper.

The specific conductivity decreases with time. This is true in every case except with the black peaty loam, where this may be accounted for by the increase in soluble material brought into solution. It will be noted that the conductivity of the water solution in contact with this soil increased after shaking, indicating that equilibrium had not been reached. If this is taken into account, the conductivity of the solution in contact with this loam also decreases with time. It would seem that the reactions are progressive and that equilibrium is not reached for a considerable time period. This is directly in line with the change in hydrogen ion concentration determinations discussed elsewhere in this paper.

As the acid-producing substances present in the soil are extremely insoluble, as shown by the fact that the pure water extract shows little acidity with ordi-

<sup>1</sup> For method of calculating conductance for calcium and sodium ions see Bates, *J. Am. Chem. Soc.*, **35** (1913), 534; and Washburn, "Principles of Physical Chemistry," New York, 1915, p. 214, for calculated values, the equivalent conductance of calcium and potassium ions at infinite dilution being 51 and 63.3, respectively.

nary indicators, it would be expected that reactions would be exceedingly slow, especially near the equilibrium point. It will be noted in this connection that there was a much more marked change in conductivity with time at the higher concentrations of base.

The rather slow increase in conductivity would point to precipitation effects which are more marked where calcium is used as the base. Acid substances which are highly insoluble would show high reserve acidity, a condition which is quite evident in the soils investigated.

#### SUMMARY

1—A new hydrogen electrode cell has been designed which has proved satisfactory for certain types of soil investigation.

2—When an acid soil is added to a neutral salt solution the hydrogen ion concentration of the solution reaches a maximum almost immediately if the soil is wet thoroughly by the solution, but secondary reactions later cause a decrease in hydrogen ion concentration of the solution.

3—When an acid soil is added to a neutral salt solution containing a free base the base is neutralized rapidly, as indicated by the change in hydrogen ion concentration of the solution, following closely the law for equilibrium reactions, but the hydrogen ion concentration of the solution continues to rise for an unknown period.

4—There is no sharp break in the progress of base absorption by an acid soil which will warrant any arbitrary division, such as active and latent acidity, or immediate and eventual lime requirement.

5—The changes in  $\log C_H$  approach nearly straight line functions with progressive addition of base in the presence of a neutral salt solution.

6—Different indicators will give differences in lime requirement for soils depending upon the slope of the  $\log C_H$  curve. The greatest differences may be expected with soils high in organic matter.

7—A general explanation is given of the different results obtained by different methods for determining soil acidity.

8—When a base is added to an acid soil comparatively insoluble products are formed. Calcium produces a product less soluble than does potassium.

9—The specific conductance of a water solution of an

acid soil to which a base has been added increases with each addition of base, but the increase is greater with potassium than with calcium hydroxide, which is far too great to be accounted for by the difference in conductivity of potassium and calcium.

10—Calcium and potassium hydroxide have practically equivalent power to neutralize the acid of an acid soil.

11—The specific conductivity of a pure water solution containing a base in contact with an acid soil decreases with time.

12—An acid soil shows high reserve acidity.

13—The reaction between a water solution of a base and an acid soil is much slower than in the presence of a neutral salt.

14—The absorption of bases by acid soils is due largely to relatively insoluble acids.



ACIDITY AND ACIDIMETRY OF SOILS. III—COMPARISON OF METHODS FOR DETERMINING LIME REQUIREMENTS OF SOILS WITH HYDROGEN ELECTRODE. IV—PROPOSED METHOD FOR DETERMINATION OF LIME REQUIREMENTS OF SOILS

By Henry G. Knight

OKLAHOMA AGRICULTURAL AND MECHANICAL COLLEGE, STILLWATER,  
OKLAHOMA

Received October 14, 1919

PART III

Through the courtesy of Mr. J. W. Ames of the Ohio Agricultural Experiment Station fifteen samples of soil were obtained from a number of variously treated plots from one of the fertility sections of the Wooster farm located on silt loam soil which is derived from sandstones and shales. Ames and Schollenberger<sup>1</sup> had made determinations of the lime requirement upon these soils by the Veitch, Hopkins, Hutchinson-MacLennan, MacIntire, and vacuum methods and all were tested with litmus paper and found to give a decided reaction. "The west half of the plots had been treated with 1,875 lbs. per acre of calcium oxide in 1903, and 2,000 lbs. of limestone in 1909. The composition of the lime materials applied was such that the equivalent of 5,700 lbs. of calcium carbonate had been applied to the limed halves of the plots previous to the time samples were taken from the plots, which was three years after the last treatment with lime."<sup>2</sup> The amount of lime left was negligible. All samples gave a decided acid reaction to litmus and when mixtures of the soils with recently boiled distilled water were tested with the hydrogen electrode all showed a hydrogen-ion concentration greater than  $10^{-7}$ .

Hydrogen-ion concentrations were determined upon these soils by use of the hydrogen electrode, using 0.5 *N* potassium chloride solution containing various predetermined amounts of lime. The samples were shaken for 3 hrs. preceding the readings given in Table I.<sup>3</sup>

By interpolating the above results as straight line functions to determine the amount of lime necessary

<sup>1</sup> THIS JOURNAL, 8 (1916), 243.

<sup>2</sup> *Ibid.*, 8 (1916), 224.

<sup>3</sup> For method and apparatus see Part II, *Ibid.*, 12 (1920), 457.

TABLE I—HYDROGEN-ION CONCENTRATIONS OF SOLUTIONS CONTAINING OHIO SOILS TO WHICH FIXED AMOUNTS OF LIME HAD BEEN ADDED  
(Readings are given in volts)

PLOT	FERTILIZER	0 T.	1 T.	2 T.	3 T.	4 T.
		Lime	Lime	Lime	Lime	Lime
0	None.....	0.5174	0.5684	0.6300	0.6739	0.7450
	None. Lime.....	0.5670	0.6406	0.6850	0.7393	....
2	Acid Phosphate.....	0.5209	0.5725	0.6392	0.7000	....
	Acid Phosphate + Lime.....	0.5760	0.6561	0.6974	0.7473	....
5	Sodium Nitrate.....	0.5184	0.5671	0.6317	0.6862	0.7482
	Sodium Nitrate + Lime.....	0.5803	0.6511	0.7103	0.7540	....
11	Acid Phosphate + Mineral Potash + Sodium Nitrate.....	0.5164	0.5657	0.6308	0.6920	....
	Acid Phosphate + Mineral Potash + Sodium Nitrate + Lime.....	0.5626	0.6398	0.6865	0.7421	....
24	Acid Phosphate + Mineral Potash + Ammonium Sulfate + Lime.....	0.5445	0.6230	0.6612	0.7260	....
26	Bone Meal + Mineral Potash + Sodium Nitrate.....	0.5209	0.5731	0.6375	0.6774	0.7394
	Bone Meal + Mineral Potash + Sodium Nitrate + Lime.....	0.5516	0.6265	0.6841	0.7312	....
29	Basic Slag + Mineral Potash + Sodium Nitrate.....	0.5220	0.5794	0.6271	0.6826	0.7339
	Basic Slag + Mineral Potash + Sodium Nitrate + Lime.....	0.5668	0.6424	0.7074	0.7467	....
18	Manure.....	0.5202	0.5659	0.6164	0.6622	0.6938
	Manure + Lime.....	0.5574	0.6163	0.6708	0.7218	....

to lower the hydrogen-ion concentration to  $10^{-7}$ , using 0.69 volt as the potential at this concentration, a comparison may be made directly with the results given by Ames and Schollenberger.<sup>1</sup> This comparison has been made in Table II. The results are given in pounds of lime as  $\text{CaCO}_3$  required per acre.

TABLE II—COMPARISON OF THE AMOUNTS OF LIME REQUIRED BY OHIO SOILS AS SHOWN BY VARIOUS METHODS

PLOT	FERTILIZER	Hopkins'	Veitch	MacIntire	Hutchinson	Vacuum	Hydrogen Electrode
1	None.....	3440	2000	3550	2925	7300	6456
	None. Lime.....	100	Alk.	2250	1700	4900	4225
2	Acid Phosphate.....	2640	2000	3850	2700	7800	5670
	Acid Phosphate + Lime.....	80	Alk.	2400	975	3800	3640
5	Sodium Nitrate.....	3640	1200	3550	2550	6200	6122
	Sodium Nitrate + Lime.....	120	Alk.	2500	1250	4225	3310
11	Acid Phosphate + Mineral Potash + Sodium Nitrate.....	3080	1800	3850	2825	7100	5960
	Acid Phosphate + Mineral Potash + Sodium Nitrate + Lime.....	80	Alk.	2500	1375	5900	4126
24	Acid Phosphate + Mineral Potash + Ammonium Sulfate + Lime..	4240	3000	4000	2700	8300	4889
26	Bone Meal + Mineral Potash + Sodium Nitrate.....	2940	2000	3700	2250	7350	6407
	Bone Meal + Mineral Potash + Sodium Nitrate + Lime.....	360	Alk.	2900	1325	4050	4250
29	Basic Slag + Mineral Potash + Sodium Nitrate.....	2560	1200	3600	2250	6600	6288
	Basic Slag + Mineral Potash + Sodium Nitrate + Lime.....	150	Alk.	2100	1075	4050	3460
18	Manure.....	2760	2600	4200	3100	8500	7760
	Manure + Lime.....	120	Alk.	2950	1950	5200	4937

<sup>1</sup> Ohio Experiment Station, *Bulletin* 306 (1916), 350. Hopkins' values are given as one-half that given in the table here, for which no explanation is offered.

The following conclusions may be drawn from a study of Table II:

<sup>1</sup> *Ibid.*, 8 (1916), 244.



1—The vacuum method approaches nearer to the lime requirement as shown by the hydrogen electrode than do any of the other methods, but with this method the results are uniformly higher. It may be assumed that if the soils had been shaken with the lime for a longer period than 3 hrs. the lime requirement as shown by the hydrogen electrode would have approached that given by the vacuum method.

2—It is quite evident that the above methods, with the possible exception of the vacuum method, do not indicate the amount of lime necessary to completely neutralize a soil, especially in the presence of neutral salts, except for a very limited period.

#### PART IV

The hydrogen electrode is not to be recommended for determination of the lime requirement of soils except as it may be valuable for checking other methods for the following reasons:

1—It is difficult to manipulate even by one who has had considerable experience in using it.

2—The process is slower than any method so far proposed.

3—Expensive and delicate apparatus is required if satisfactory results are to be obtained.

Although it may be found valuable for standardizing other methods, and approximate lime requirement values may be obtained by making two determinations and calculating the lime requirement as a linear function, the method cannot be taken seriously as a commercial laboratory method.

As the time element is an important factor automatic titration would not be entirely satisfactory. On account of the difficulties enumerated above, further investigations were made in the hope that a practical, rapid method for the determination of the lime requirement of a soil could be worked out.

Tacke's method<sup>1</sup> would appear to have a logical foundation but in the light of the present investigations it is difficult to conceive how it could be expected to yield concordant results, and it is doubtful if it or any of the proposed modifications would approach the actual amount of lime needed to bring the soil to true neutrality.

An attempt was made to determine the lime requirement by mixing a weighed quantity of soil with precipitated calcium carbonate, adding recently boiled distilled water, boiling for a fixed period, and deter-

<sup>1</sup> *Chem.-Ztg.*, 20 (1897), 174.

mining the evolved carbon dioxide by the Parr method<sup>1</sup> as modified by Pettit.<sup>2</sup> Concordant results could not be obtained, but by adding a neutral salt rather close results were obtained.

The method used for the results given in Tables I and II below was to take a weighed sample of soil, usually 5 or 10 g., add an excess of precipitated calcium carbonate in a 125 cc. Erlenmeyer flask, attach to the Parr apparatus, run in about 25 cc. of normal salt solution,<sup>3</sup> and boil for a definite period.<sup>4</sup> The flask

TABLE I.—COMPARISON OF LIME REQUIREMENTS OF OHIO SOILS AS SHOWN BY VARIOUS METHODS, INCLUDING THE PROPOSED MODIFIED TACKE METHOD, AND THE DIFFERENCES SHOWN BY LIMED AND UNLIMED PLOTS. PREVIOUS APPLICATION OF LIME ON LIMED PLOTS 5700 LBS. PER ACRE

PLOT	FERTILIZER	Hopkins	Veitch	MacIntire	Hutchinson	Vacuum	Hydrogen Elec- trode	Modified Tacke 5 Min.	Modified Tacke Boiled 10 Min.
0	None.....	3440	2000	3550	2925	7300	6456	6941	7783
	None + Lime.....	100	Alk.	2250	1700	4900	4225	..	6908
	Difference.....	3340	..	1300	1225	2400	2231	..	875
2	Acid Phosphate.....	2640	2000	3850	2700	7800	5670	6737	7809
	Acid Phosphate + Lime	80	Alk.	2400	975	3800	3640	5123	6599
	Difference.....	2560	..	1450	1725	4000	2030	1644	1210
5	Sodium Nitrate.....	3640	1200	3550	2550	6200	6122	7264	7924
	Sodium Nitrate + Lime.	120	Alk.	2500	1250	4225	3310	..	5431
	Difference.....	3520	..	1050	1300	1975	2812	..	2493
11	Acid Phosphate + Mineral Potash + Sodium Nitrate.....	3080	1800	3850	2825	7100	5960	7042	7493
	Acid Phosphate + Mineral Potash + Sodium Nitrate + Lime.....	80	Alk.	2500	1375	5900	4126	..	6184
	Difference.....	3000	..	1350	1450	1200	1834	..	1309
24	Acid Phosphate + Mineral Potash + Sodium Nitrate + Ammonium Sulfate + Lime.....	4240	3000	4000	2700	8300	4889	..	6547
26	Bone Meal + Mineral Potash + Sodium Nitrate.....	2940	2000	3700	2250	7350	6407	6973	7530
	Bone Meal + Mineral Potash + Sodium Nitrate + Lime.....	360	Alk.	2900	1325	4050	4250	..	6951
	Difference.....	2580	..	800	925	3300	2157	..	579
29	Basic Slag + Mineral Potash + Sodium Nitrate.....	2560	1200	3600	2250	6600	6288	..	7822
	Basic Slag + Mineral Potash + Sodium Nitrate + Lime.....	150	Alk.	2100	1075	4060	3460	..	6233
	Difference.....	2410	..	1500	1175	2540	2828	..	1589
18	Manure.....	2760	2600	4200	3100	8500	7760	8327	8776
	Manure + Lime.....	120	Alk.	2950	1950	5200	4937	..	7206
	Difference.....	2640	..	1250	1150	3300	2823	..	1570

<sup>1</sup> *J. Am. Chem. Soc.*, 26 (1904), 294.

<sup>2</sup> *Ibid.*, 1640.

<sup>3</sup> Preliminary experiments showed that it made little difference what neutral salt was used. Experiments were made with definite quantities of KCl, NaCl and KNO<sub>3</sub>; also by varying the amount of calcium carbonate and KCl with duplicate results, provided there was an excess of calcium carbonate and not enough neutral salt to change materially the boiling point of the solution.

<sup>4</sup> If the boiling was attended with frothing a few drops of a neutral oil were added.

and condenser were filled with distilled water to a mark upon the capillary tube connecting the condenser with the eudiometer. Readings were taken as instructed by Pettit.<sup>1</sup> It is recommended that 10 min. be fixed as the time for boiling.

The soils given in Table I are the ones described by Ames and Schollenberger<sup>2</sup> and received by the writer from them. The results are calculated in pounds of calcium carbonate to 2,000,000 lbs. of soil, except in case of peat soils where 1,000,000 lbs. were used as a basis.

Other soils investigated are given in Table II. Hopkins and hydrogen electrode determinations were made and the proposed modified Tacke determinations were made after boiling for 5, 10, and 30 min.

TABLE II—LIME REQUIREMENTS OF SOILS AS SHOWN BY THE HOPKINS, THE HYDROGEN ELECTRODE, AND THE PROPOSED MODIFIED TACKE METHODS<sup>1</sup>

SOILS	Hopkins	Hydrogen Electrode	Proposed Modified Tacke Method		
			5 Min.	10 Min.	30 Min.
Yellow-Gray Silt Loam.....	8400	12490	14847	15822	...
Black Peaty Loam.....	6890	32420	...	...	...
Black Clay Loam.....	9964	38026	...	34718	...
Peat.....	6535	34260	11011	20772	...
Black Muck.....	8112	(?)	...	31342	...
Yellow Silt Clay.....	10160	14708	...	...	...
Gray Clayey Silt.....	15840	(*)	28803	30640	33624
Gray Plastic Clay.....	5200	10000	...	11094	...
Yellow Plastic Clayey Silt.....	9340	14650	18173	19611	...
Yellow Silt Loam.....	5780	14578	13453	14954	17250
Brown Sandy Loam.....	3300	4574	...	5792	...

<sup>1</sup> For descriptions of soils see Part I, THIS JOURNAL, 12, (1920), 340.

<sup>2</sup> More than 40000.

<sup>3</sup> More than 20000.

It will be noted that the proposed modification of Tacke's method gives varying results which depend upon the time of boiling, and in every case except for peat and yellow silt loam, Table II, the 5-min. boiling period showed a higher lime requirement than the hydrogen electrode. A 10-min. boiling period showed a higher lime requirement in every case except one (Ohio Plot No. 24, lime, Table I) than did the vacuum method proposed by Ames and Schollenberger.<sup>3</sup> That the reaction is not complete even at the end of the 10-min. period is shown by the increase at the end of a 30-min. boiling period.

The proposed method has the advantage over most of the others in that it gives a figure which represents the "power of a soil to decompose calcium carbonate"

<sup>1</sup> *Loc. cit.*

<sup>2</sup> THIS JOURNAL, 8 (1916), 243.

<sup>3</sup> *Loc. cit.*, Part III.

(which may be assumed to be a measure of the eventual lime absorption), is rapid, and approximates the results obtained with the hydrogen electrode.

It is quite apparent that the interaction at room temperature between a soil and a caustic lime solution containing a neutral salt is not complete within 3 hrs. (which is the period at which hydrogen-ion concentrations were determined with the hydrogen electrode), as shown by both the vacuum and the modified Tacke methods. The period required for the completion of the interaction at room temperature between a soil and calcium carbonate may be assumed to be considerable for MacIntire<sup>1</sup> has shown that calcium passes slowly into the form of silicates.

It is quite evident that any of the proposed methods gives comparative results only. The true lime hunger as it relates to cropping is after all the matter that we are most interested in determining, and this, it seems, with the present state of our knowledge must be determined by field experiments.

#### MEASUREMENT OF THE REDUCTION OF ACIDITY

By subtracting the acidity values found in acid soils from those found in unlimed soils from the corresponding half plots at the Ohio Station (Table I) differences are obtained which measure the residual reduction in acidity due to previous applications equivalent to 5,700 lbs. of calcium carbonate. As an average of the results from seven plots which afford data for this measurement the reduction in acidity is 2,864 lbs. by the Hopkins method, 2,674 by the vacuum method, and 2,388 by the hydrogen electrode, while the MacIntire, Hutchinson and modified Tacke methods show reductions of 1,243, 1,279, and 1,375 lbs., respectively. That any method will show a greater reduction in acidity than actually occurs and remains at the time of sampling seems extremely doubtful.

As suggested above, the vacuum method appears to furnish the most trustworthy measure of the total lime requirement and it also seems safe to assume that the hydrogen electrode will give results in substantial agreement with the vacuum method if sufficient time is allowed. If these methods are accepted as standards, then the Hopkins method seems to give correct results when used to measure the reduction in soil acidity by applications of lime. It may also measure with accuracy the most immediate lime need, although it does not

<sup>1</sup> Tennessee Experiment Station, *Bulletin* 107 (1914).

measure the total power of a soil to decompose carbonates.

If we assume that the reduction in acidity should be approximately the same for all limed plots, the Hopkins method and the hydrogen electrode show the highest percentage consistency.

#### CONCLUSIONS

1—A method has been proposed for determining the power of a soil to decompose calcium carbonate which approximates the results obtained by use of the hydrogen electrode.

2—The Hopkins and the hydrogen electrode methods show the highest percentage consistency for measuring the reduction of acidity for limed soils.



## V I T A

Henry Granger Knight was born at Bennington, Ottawa Co., Kansas, July 21, 1878. He secured his common school education in the public schools of Kansas and Washington. The first two years of high school work was pursued at Leland, Washington; the third year was completed at the Port Townsend High School, from which institution he received a diploma in 1896. In the fall of 1897 he entered the University of Washington at Seattle as a conditioned freshman. He graduated from this institution in June 1902 with the degree of Bachelor of Arts with honors in Chemistry. During the years 1898-1899, 1900, 1901-1902, he held the position of Assistant in Chemistry at the University of Washington.

He entered the University of Chicago in July, 1902, as a member of the Graduate School where he studied chemistry under the direction of Dr. McCoy until August 1903, at which time he left to accept a position of Assistant Professor of Chemistry at the University of Washington. In January 1904 he was elected Professor of Chemistry at the University of Wyoming. He was granted the degree of Master of Arts by the University of Washington in 1904 upon work at the University of Washington, the University of Chicago and a thesis completed at the University of Wyoming. While holding this position in the summer of 1906 he attended the summer school of the University of Chicago. In June 1910, he was appointed Director of the University of Wyoming Agricultural Experiment Station and Agricultural Chemist of the Agricultural College and one year later was also appointed Dean of the Agricultural College. In September 1915, he was granted a leave of absence to carry on graduate work at the University of Illinois.

He is the senior author of Bulletin No. 62, "Some Food Products and their Adulteration;" Bulletin No. 65, "Wyoming Forage Plants and their Chemical Composition—Studies No. 1;" Bulletin No. 69, "Digestion Experiments with Wethers;" Bulletin No. 70, "Wyoming Forage Plants and their Chemical Composition—Studies No. 2;" Bulletin No. 76, "Wyoming Forage Plants and their Chemical Composition—Studies No. 3;" Bulletin No. 78, "Digestion Experiments II;" Bulletin No. 82, "Soil Nitrogen;" Bulletin No. 87, "Wyoming Forage Plants and their Chemical Composition—Studies No. 4;" Bulletin No. 97, "The Identification of the Woody Aster;" Bulletin No. 100, "Meteorology for Twenty Years;" and "Alkali VI," Sixteenth Annual Report; all of which have been published by the University of Wyoming Agricultural Experiment Station. He is the junior author of "Notes on Qualitative Analysis," published by John Wiley and Sons, and Bulletin No. 94, "The Chemical Examination of Death Camas," published by the University of Wyoming Agricultural Experiment Station.

In 1903 he was Fellow elect at Chicago. He is a member of the Washington Chapter of Sigma Xi and of Phi Beta Kappa, and of the Illinois Chapter of Sigma Upsilon, The American Chemical Society, National Geographic Society, the Society for the Promotion of Agricultural Science, et cetera.



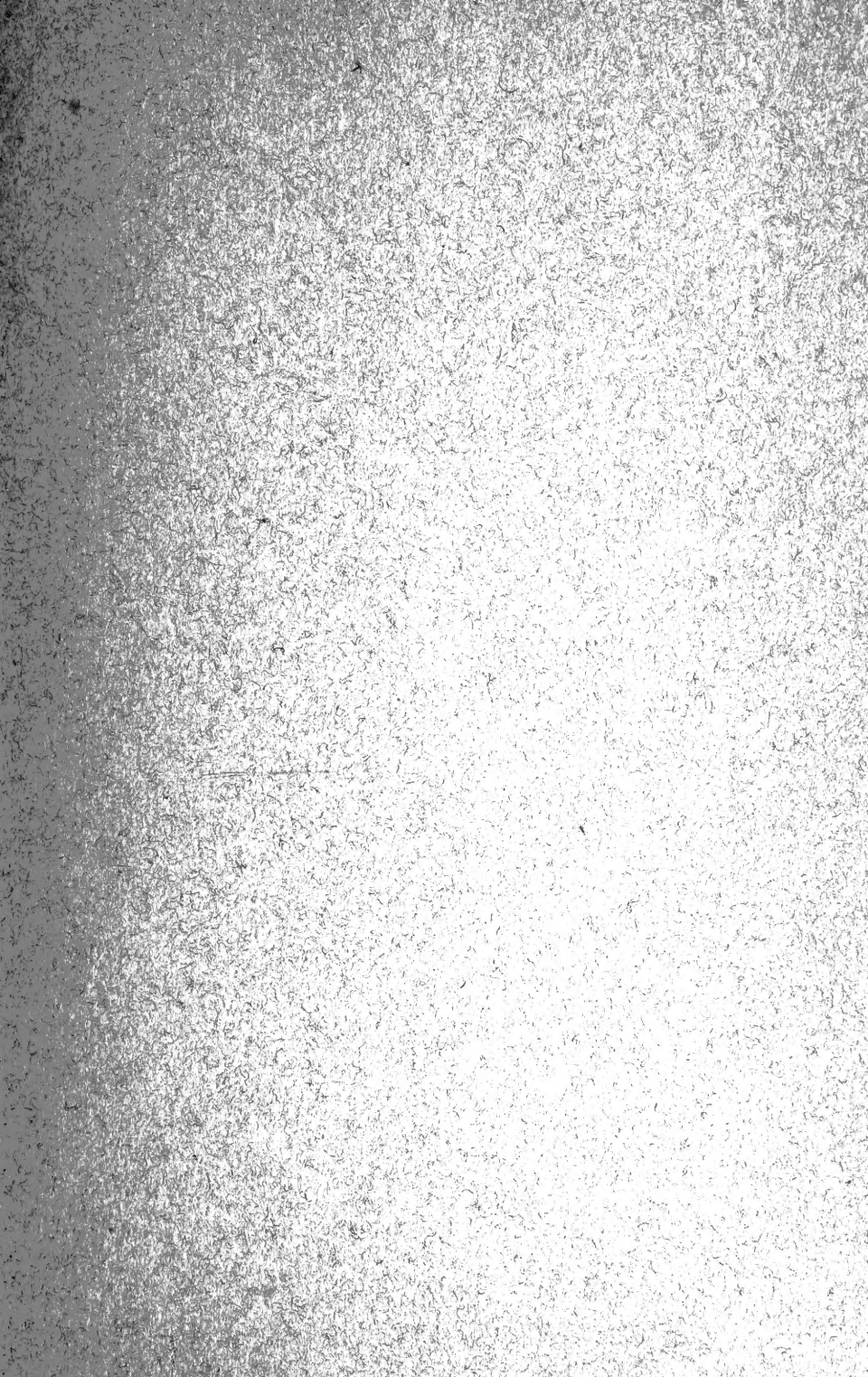

LIBRARY OF CONGRESS



0 002 781 556 A ●