

JANUARY, 1874.

AMERICAN

AGRICULTURIST

FOR THE FARM, GARDEN & HOUSEHOLD.



Vol. XXXIII

Number 1.

PUBLISHED BY THE
ORANGE JUDD COMPANY
245 BROADWAY,
NEW-YORK.

Standard Architectural Books for Carpenters and Builders.



Monckton's National Builder and Stair-Builder.—A new and original work, covering every practical branch of Constructive Carpentry, with 1,000 Working Scale Drawings, in two colors. Showing the simplest methods of fitting all Joints and Forms; method of constructing all varieties of French Roof; all other methods of Roofing, all styles of Framing; Splayed Work, Ceilings, Domes, Niches, Raking and Level Moldings, etc., with a Treatise on Stair Building and Hand-Railing, and Designs for Stair-Cases, Newels, Balusters, and Hand-Rails. One royal quarto volume, uniform with "Woodward's National Architect." Post-paid, \$12.00.

The above work is also divided and published in two volumes as follows:

Monckton's National Stair-Builder.

—Is a complete work on Stair-Building and Hand Railing. Fully explained and illustrated by large scale diagrams, in two colors, with designs for Staircases, Newels, Balusters, and Hand-Rails. Royal Quarto. Post-paid, \$3.00.

Monckton's National Carpenter and Joiner.

—A complete work, covering the whole science of Carpentry, Joinery, Roofing, Framing, etc., fully explained and illustrated by large scale diagrams in two colors. Royal Quarto. Post-paid, \$6.00.



Woodward's National Architect.

—1,000 Designs, Plans, and Details for Country, Suburban, and Village Houses; with Perspective Views, Front and Side Elevations, Sections, Full Detail Drawings, Specifications, and Estimates. Also, Detail Drawings to Working Scale, of Brackets, Cornices, French Roofs, Sectional and Framing Plans of French Roofs, Dormer-Windows for French Roofs, Bay-Windows, Verandas, Porches, Plaster Finish, Cornices, Ceilings, Hard-wood Mantels, and all that is required by a Builder to design, specify, erect, and finish in the most approved style. One superb quarto volume. Post-paid, \$12.00.

Woodward's Cottages and Farm Houses.—188 Designs and Plans of low-priced Cottages, Farm Houses, and Out-Buildings. Post-paid, \$1.50.

ORANGE JUDD COMPANY, Publishers, 245 Broadway, New York.

Woodward's Suburban and Country Houses.—70 Designs and Plans, and numerous examples of the French Roof. Post-paid, \$1.50.



Woodward's Country Homes.

—150 Designs and Plans, with Description of the Manner of Constructing Balloon Frames. Post-paid, \$1.50.

Woodward's Graperies and Horticultural Buildings.

—Designs and Plans of Hot Beds, Cold-Pits, Propagating Houses, Forcing Houses, Hot and Cold Graperies, Green Houses, Conservatories, Orchard Houses, etc., with the various modes of Ventilating and Heating. Post-paid, \$1.50.

Wheeler's Rural Homes.

—Houses suited to Country Life. Post-paid, \$2.00.

Wheeler's Homes for the People.

—100 Original Designs, with full Descriptions, and Constructive and Miscellaneous Details. Post-paid, \$3.00.

Harney's Barns, Out-Buildings, and Fences.

—Containing Designs and Plans of Stables, Farm Barns, Out-Buildings, Gates, Gateways, Fences, Stable Fittings and Furniture, with nearly 200 Illustrations. Royal quarto. Post-paid, \$10.00.

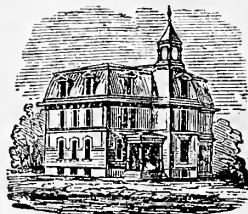

Eveleth's School-house Architecture.

—A new and original work, containing Seventeen Designs for School-houses, Sixty-seven Plates with Perspectives, Elevations, Plans, Sections, Details, Specifications all drawn to working scale, with methods of Heating and Ventilation. Large quarto. Post-paid, \$10.00.

Copley's Plain and Ornamental Alphabets.

—Giving examples in all styles, together with Maps, Titles, Borders, Meridians, Ciphers, Monograms, Flourishes, etc., adapted for the practical use of Surveyors, Civil Engineers, Draughtsmen, Architects, Sign Painters, Schools, etc. Post-paid, \$3.00.

CUMMINGS' Architectural Details.

CONTAINING

387 Designs and 967 Illustrations

Of the Various Parts Needed in the Construction of Buildings, Public and Private, both for the City and Country.

ALSO, PLANS AND ELEVATIONS OF

Houses, Stores, Cottages, and Other Buildings.

BY

M. F. CUMMINGS, A.M., Architect,

Associate Author of "Architecture, by Cummings & Miller," and "Modern American Architecture, by Cummings & Miller."

Nearly eight years ago, the author of this work, in connection with Mr. C. C. Miller, architect, published a work on architectural details, which, as soon as it was presented to the architects, carpenters, and builders of the country, met with a rapid sale; and, judging from the number of editions through which it has passed, and the great circulation reached, it must have met the approval of those most interested in practical architectural works, and must have filled, in a measure, a want before unsupplied.

The success of that book has induced the author to publish a second one, which is now presented to the public, and in it will be found an extensive collection of designs illustrating the features which go to make up structures such as are needed to meet the wants of the American people.

What has been aimed at is this: To present a mass of architectural details, easy of construction, pleasing in form, and generally of an inexpensive character, and all so designed that a great variety of selections may be made from them, which, when combined in a building, will produce a harmonious whole; and it is believed by the author that this work will be found to be of value, and that its design is practicable, for there are hundreds of towns and villages, in all the States of the Union, in which the wants of the people continually demand the erection of buildings, largely of wood, and which in the hands of the builder and workman may be made elegant and pleasing in all their features, provided they have at hand a guide such as this book is intended to be.

Royal Quarto. Price, post-paid, \$10.

ORANGE JUDD COMPANY,

245 BROADWAY, NEW YORK.

THE NEW REMEDY FOR RUPTURE published by the Elastic Truss Co. at 683 Broadway, New York City, is now the only real remedy for Hernia. The Surgeon-General of the U. S. at Washington has arranged with the Truss Co. to supply their new Truss to the soldiers and sailors, pensioners, as they may need it. It has received the highest medal at the great Cincinnati Exposition, also the highest medal of the great Fair of the American Institute for 1873 at New York. The Committee of the Institute were John Osborn, M.D., No. 254 West 34th st., N. Y.; D. F. Fetter, M.D., No. 292 West 34th st., New York, and C. D. Varley, M.D., No. 318 West 22d st., N. Y. The Committee say of the Elastic Trusses sold at 683 Broadway "are superior to all others on exhibition, or that have heretofore come to our knowledge, in their perfect adaptability to the person, and also in the comfort with which they retain the bowel," etc. Call or send for a Circular. Suffering from Rupture is entirely unnecessary.

INVENTORS Who wish to secure PATENTS should write to H. C. W. & CO. 27 Park Row, New York, for Advice and Pamphlet, 100 pages, FREE.

Aggr. Ind.

Aggr. Ind.

13-6359

THE
AMERICAN
AGRICULTURIST.

FOR THE
Farm, Garden, and Household.

"Agriculture is the most Healthful, the most Useful, the most Noble Employment of Man."—WASHINGTON.

VOLUME THIRTY-THREE—FOR THE YEAR 1874.

SMITHSONIAN INSTITUTION
WASHINGTON 25. D.C.

NEW-YORK:
PUBLISHED BY ORANGE JUDD COMPANY,
245 BROADWAY.

AMERICAN AGRICULTURIST

FOR THE

Farm, Garden, and Household.

"AGRICULTURE IS THE MOST HEALTHFUL, MOST USEFUL, AND MOST NOBLE EMPLOYMENT OF MAN."—WASHINGTON.

ORANGE JUDD COMPANY,
PUBLISHERS AND PROPRIETORS.
Office, 245 BROADWAY.

ESTABLISHED IN 1842.

Published also in German at \$1.50 a Year.

{ \$1.50 PER ANNUM, IN ADVANCE,
SINGLE NUMBER, 15 CENTS.
{ 4 Copies for \$5; 10 for \$12; 20 or more, \$1 each.

Entered according to Act of Congress, in December, 1873, by the ORANGE JUDD COMPANY, at the Office of the Librarian of Congress, at Washington.

VOLUME XXXIII.—No. 1.

NEW YORK, JANUARY, 1874.

NEW SERIES—No. 324.



ORANGE JUDD.

Contents for January, 1874.

Table listing contents for January 1874, including Bee Notes for January, Boys and Girls' Columns, Doctor's Talk, Game for Winter Evenings, Bull, Beacon Comet, Cattle Herd-Book, Cistern, Cold Grapery, Corn-Cribs, Corn, Kihl-Drying, Cottage, Design for a Cotton-Seed Cake Meal, Cranberries, Farm Work for January, Flower Garden and Lawn for January, Fruit Garden for January, Greenhouse and Window Plants for January, Hare, The Little Chief, Household Department, Instruments, Kitchen Garden for January, Market Report for January, Notes from the Pines, Ogden Farm Papers, Orange Judd, Orchard and Nursery for January, Patrons of Husbandry, Pig-Pen, Plant, Hoya or Wax, Plants, Indian Tobacco, Plants, Southern Pitcher, Potatoes, American in England, Sheep, Native Races of, Sleds, How Built, Steam on the Canal, Timber Tong, Tomato, One Hundred Dollars for a, Two Crops at Once, Walks and Talks on the Farm, Watering-Pot, New French, What Crops Leave in the Soil.

INDEX TO "BASKET," OR SHORTER ARTICLES. Aftermath, Too Heavy, Am. Dairymen's Assoc., American Rural Home, Ashes, Beacon Comet, Beef from Texas, Blue-Grass, Kentucky, Bone-Dust upon New Land, Bone Mill, Brahma Cattle, Naked, Brewers' Grains, Value of, Broom Machinery, Catarrh in Sheep, Prevention of, Cats, Change of Seed, Cheese, English, China or Earth Almond, Cistern, Capacity of, Clover Sod for Wheat, Colt, For a Jumping, Cooperative Store, Copper-Strip Cut, Gale's, Corn, Cost of a Crop of, Cotswolds, Cotton and Flax-Seed Meals, Cotton-Seed, Cooking, Cow, A Good Native, Cow, Value of a, Cure for Curb, Dairy Farms, Renting, Dandelion, Northern Linseed, Eggs, To Preserve, Epizootic and its Results, Farm Labor for America, English, Fertilizers, Manufacture of, Fertilizers upon Oats, Fine Catalogue of a Fine Library, Florida Settler, Frequent Working, Fruit near Chicago, Garden Library, Grain Drills, Grape, Taylor or Bullit, Grape-Vines run Wild, Grass for Pasture, Grass, Salt Muck for, Gregory's Specialties, Ground Bone, Harrow, How to Make a, Harrowing Wheat and Sowing Timothy, Harvest-Home Festivals, Hives, Homestead, How to Get a, Homesteader in Minn., Horses, Percheron and Norman, Horse-Shoeing, Instruction in, Indigestion in the Horse, Information Wanted, Injection Syringe, Irrigation by Flooding, Ithaca Horse Rake, Knitting Machine, Larch, Scotch, Manure, Management of, Mich. State Pom. Society, Much Castor-Oil, Muck on Sandy Soils, Mushroom, Mushrooms, Orchard Planting and Vinegar, Othonna-Correction, Our Western Office, Oyster-Shell, How to Colt, Pastures, Poisonous, Pears, Peas and Oats, Petroleum for Shingles, Pickle for Sugar-Cured Hams, Plants Named, Plaster upon Wheat, Pleuro-Pneumonia, Plows, Sulky, Pollen in the Atmosphere, Pork, Smoking, Potato Rot, Poultry, Hard Crop and Vertigo in, Poultry, Houses, Poultry upon a Large Scale, Question of Morality, Reports, Catalogues, and Journals, Rye, How to Feed, Sheep in New Mexico, Sheep vs. Goats, Solvents for Gutta Serena and Caoutchouc, Spreading Lime in Winter, State Granges, Strawberries, Tan-Bark for, Sundry Humbugs, Swelling of the Legs, Swollen Neck, The English of It, Tomato, Grape, Turkeys, Bronze, Virginia, As to, Weeds, Killing, Weevil in Barms, What Shall we Have for Breakfast?, White Spots.

Calendar for January.

Calendar for January showing sunrise, sunset, moonrise, moonset, and moon phase for various locations: Boston, N. England, N. York State, Michigan, Wisconsin, Iowa, and Oregon; N. Y. City, Pa., Philadelphia, New Jersey, Penn., Ohio, Indiana, and Illinois; Washington, Maryland, Virginia, Kentucky, Missouri, and California.

PHASES OF THE MOON.

Table showing moon phases for Boston, N. York, Wash'n., Cha'ston, and Chicago, including Full Moon, 3d Quart., New Moon, and 1st Quart.

AMERICAN AGRICULTURIST.

NEW YORK, JANUARY, 1874.

The present season is one of enforced comparative idleness. Holiday keeping will help to whittle away a portion of the farmer's time, after which, although the hands may be idle, there is much head-work to do. The new year is the time for laying plans for the future, and no employment needs more careful thought than this matter of laying plans. The better the plan the more profitable will be the work. No work needs more planning than farming. It is not a business to be done on the spur of the moment; and at the commencement of the year the whole future labor of the season should be laid out distinctly and thoughtfully. Then when the emergency comes one is prepared for it. This is the great secret of success in all business, and is that which often enables the less able and confident man to come out ahead of his more sanguine and more capable neighbor. Now is a good time for commencing a farm record, a book in which the farm should be mapped out, the plan of work for the season written down, the needed supplies of seeds, etc., noted, and in which at the close of each day there should be recorded the condition of the weather and the various occurrences worthy of being remembered. Especially should be set down such things as the farm operations, births, etc., of animals, payments and receipts of money, engagements or contracts, and all under the proper dates. Such a book is an interesting study in after times, and is useful as a guide to future work and calculations, and has often saved money by reason of its being able to furnish either direct proof or corroborative testimony of payments or contracts.

Hints about Work.

A Sharp Eye is of the greatest use at this cold season. Stock needs watching with care. No falling off in condition should be permitted. A little extra feed now will do great good, and will doubtless save a large expenditure two months hence. Besides, it is easier to keep up than to bring up the condition of an animal.

Cellars need ventilating and extra protection against sudden cold snaps.

A Plentiful Supply of Water is quite indispensable to the welfare of farm stock. Ice-cold water is injurious and wasteful. A bucket of such water will destroy the good effect of several good feeds. The water-trough should be kept free from ice, and it should be emptied as soon as the stock has been watered. Many people believe that sheep can live without drinking, but this is a great mistake. All animals fed upon dry feed need water frequently. Snow is no substitute for water.

Young Stock need especial care, and exposure to damp in mild or thawing weather is more hurtful than dry though comparatively severe cold.

Manure should be gathered and worked with care. If allowed to freeze it remains unaltered until late in spring. That intended for root crops should be worked over, and piled up neatly with straight sides and flat top, so that it may receive as much moisture as possible. Labor spent in working over manure is well spent. Three turnings will bring it into a condition for use in early spring.

Oil-Cake Meal will be found a very valuable addition to the feed just now. Dry feed tends to a constipated condition, which soon shows in staring hide and tight skin. A pound or even a few ounces of linseed cake meal, which costs about a cent and a half a pound, given each day to horses or cattle will loosen their bowels and improve their health. Calves and sheep should also not be neglected in the distribution.

Vermin should be watched for. A weekly allowance of sulphur given in some salt will tend to keep down vermin. Sulphur rubbed up with lard makes a good application against lice if rubbed along the spine of an animal infested. Whale-oil is also a good application. Carbolic acid and kerosene should be used with caution; they may do more harm than good if too freely used.

Snow is easily removed from paths and from the platform of the pump, etc., if attended to promptly. If trodden down the labor is greatly increased. Let the work be done the first thing every morning, and also frequently during the day if snow is falling. Nothing is gained by delay. Do not wait until the storm is over before breaking the roads about the premises. Get out the teams and keep the roads open. If you have not a snow-plow a pair of harrows will level the drifts and help to pack the snow. It is not so important how the work is done—only do it, and do it promptly.

In Starting a Heavy Load on a Sleigh be certain that the runners are not frozen to the snow, and, if possible, help the team by moving the sleigh ahead a few inches with a lever at starting.

Horse-Shoeing is a very important as well as an expensive item. A horse should be kept sharp shod in winter or not shod at all. Many a good horse is ruined for want of attention to this matter.

Farm Horses kept in the stable and only worked occasionally should be fed and managed with care. A common mistake is to let them do nothing for several days and then "put them through." A sharp trot for a mile or two until the sweat starts will do no harm, but rather good, provided they are rubbed dry afterwards. But to drive them rapidly eight or ten miles, let them stand in the cold for an hour or two and then drive them rapidly home, and give them little care when they get home, is thoughtless and cruel.

A Warm Bran-Mash is a good thing to give a horse when he is brought home hot and exhausted from a long journey. Blanket him at once, and rub his ears and legs, and then rub his belly and flanks and such other parts of the body as can be got at without wholly removing the blanket. If your man thinks this too much trouble, and will not do the work willingly, discharge him. Better part with a man than lose a good horse.

Cows that are expected to calve in March or April should, as a rule, be dried off this month. New milch-cows, or cows that calved last fall, should be fed liberally with food favorable to the

production of milk, such as roots, bran, corn-stalks, clover hay, and three or four quarts of corn-meal per day. Warm slops or cooked food will increase the flow of milk. Warm and well ventilated stables are also essential. If the cows are turned out to water be careful not to let them stay out long enough to get chilled. Farrow cows that are giving milk should have an abundant supply of rich food. They may have as much as four or five quarts of corn-meal a day. If they get fat instead of giving milk you can dispose of them to the butcher. Beef is likely to be higher.

Sheep should have dry quarters. Dry cold is better for them than warm, wet weather. Avoid close, damp, ill-ventilated basements; also be careful not to use so much straw for bedding in the sheds and yards that the manure will ferment under the sheep. Nothing can be worse.

Swine that are fat must either be sold or put into the pork barrel on the farm. The packers have matters in their own hands this year. Next year we shall get better prices. Last spring or summer pigs that are in thrifty condition will pay to winter over. Their summer feed when clover is abundant will cost but little, and they will make good and cheap pork early next fall.

Poultry should have fresh meat of some kind during the winter. Keep the hen-house clean, light, warm, and well-ventilated. Select out all the hens and roosters you do not wish to keep. Shunt them up by themselves and fatten them. A fat hen or rooster, even though somewhat advanced in age, is not bad eating. Look out for a change of roosters. On a farm where a good many hens are kept of no special breed it is well to select at least one or two roosters of a breed distinguished for early maturity and fattening qualities rather than of those species valuable as egg-layers.

Work in the Horticultural Departments.

We should be glad if every reader of the *Agriculturist* who has a bit of land to cultivate would resolve that during the coming season he would make a strong effort to have a garden where could be grown the necessary vegetables and as many fruits as space and time would allow. Too many farmers look upon the garden as a needless luxury, and the consequence is that they, of all other classes, have the least variety of vegetables and fruits upon their tables. They do not realize the benefit of a proper intermixture of vegetables with meat, and how necessary they are to health. It is a fact that people living in cities have a greater variety of vegetables the year through than the farmer. The cost of a garden is but slight, and, with the exception of the plowing and carting of manure, could all be done by children; besides, the interest the work would excite would be of great value in preventing their leaving the farm. Many a boy who is now a successful farmer dates his interest in agricultural and horticultural pursuits from the sense of his responsibility while attending to the garden or some department of the farm. So we say to all farmers, advance your own interests by interesting your children in the garden.

Orchard and Nursery.

Though January will not be thought a favorable month to attend to work in this department, yet on a second consideration many operations which can be done now will suggest themselves to the wide-awake orchardist. There will be

Cions to cut when the wood is not frozen, as a larger proportion are likely to live if cut at this season than when left until spring, as the severity of the weather often injures the buds. Take particular care to have every variety properly labeled and packed in fresh sawdust or sand where they will not dry out during the winter.

Tent Caterpillars.—Look out now for the eggs of this destructive insect. When the trees are leafless the little bands of eggs glued around the twigs, usually near their extremities, can be

readily seen and removed. If this matter is attended to at once much time will be saved when other work is pressing in the spring.

Trees.—If trees were not ordered early in the fall order at once, so that there will not be any delay when the time to plant arrives. If there is a nursery near by it will often be best to pay an extra price for the privilege of digging or selecting the trees one's self. In selecting varieties, attention must be paid to the purpose for which they are wanted, whether for market or for home use. If for market, select such as are known to succeed well in the immediate vicinity, with a fair proportion of early and late sorts. When selecting for home use many can be planted which are of fine quality but scanty bearers or poor keepers.

Rabbits and Mice.—Look out for these animals. When a light snow falls they will often do a great deal of damage in a short time. Tramp the snow firmly around the trunks to prevent the mice from injuring the bark. Blood sprinkled upon the trees will prevent injury from rabbits.

Root Grafting can be done at this season. Graft at the "collar," and never on the tips of roots. The best tying material is waxed cotton twine.

Nursery Stock.—Head back and prune into shape during mild weather.

Map the Orchard.—In winter evenings and during very cold days when out-of-door work is impossible, a map of the orchard should be made giving the position and name of each variety. This is important, as labels are liable to be lost, and if a map with the names is made it will be an easy matter to replace them; besides, a place with the trees correctly named will bring a higher price in the market should it ever be offered for sale.

Injured Trees.—Large limbs are often broken by ice and snow; these should be looked after, and the wound carefully smoothed with a sharp knife and a coat of melted grafting-wax applied.

Fruit Garden.

Many persons think that if they have one variety of each kind of fruit that is enough. This is a mistake, and one who thus plants will not experience half the pleasure which comes from selecting a proper proportion of early and late sorts. Blackberries and raspberries can be enjoyed for some weeks longer if both early and late varieties are set out. Winter is the proper time to lay out this work, and by carefully reading and comparing the statements of the best authorities one can, with a proper soil, plant with good prospects of success. There are many works upon the different small fruits, and all contain something of interest as well as value to the fruit-raiser. Trees which have been trained as cordons ought to be safe from cattle, and in the case of apricots and peaches will be all the better if a little protection is given during the winter. Grape-vines may be pruned at any time when the weather is not too cold. At the South the work of preparing the soil and in some places planting can be carried on, but at the North little outside work can be done at this season of the year. For general directions see the hints under orchard and nursery.

Kitchen Garden.

The amount of out-of-door work which can be done this month will depend upon the mildness or severity of the season. One main point, however, should be constantly in mind, and it is that whatever is done now will facilitate the spring work. If there is a large quantity of manure to draw it can be hauled to the fields as well at this season as to wait until spring; besides, if there is a light snow on the ground it can be taken out upon a sled, thus saving a great deal of labor in the matter of loading. Manure for hot-beds may be drawn out and placed in piles large enough to prevent their being chilled through; if fermentation goes on too rapidly the piles can be turned occasionally.

Hot-Bed Sashes and Frames are to be prepared early to be ready for immediate use. The usual

size for sashes is 6 x 3 feet, but for ordinary family use an old window sash or two will answer well. The frames should be made of inch boards 10 feet high at the rear and one foot in front.

Tools.—See that all the tools in use about the garden are in good condition for the next season. They will last much longer if a coat of petroleum is applied to the wood-work and the iron and steel parts well oiled to prevent rust. There are many convenient implements which can be made by the gardener if he has a little skill in handling tools. A roller, marker, and reel for a garden line are very necessary in a garden, and can be easily made.

Cold Frame.—Care must be taken to give ventilation during every mild day. The danger is not from freezing, but from the temperature becoming so warm as to start the growth before spring.

Straw Mats for protecting hot-beds and cold-frames during cold nights may be made during leisure times.

Covering strawberries, spiuach, etc., which was neglected in the fall may be done now if there is not much snow on the ground.

At the South hot-beds may be started in favorable localities, and radish, lettuce, and cabbage plants started, while hardy vegetables may be sown in the open ground.

Flower Garden and Lawn.

During the winter the value of a proper proportion of evergreen trees and shrubs becomes apparent. A lawn on which are planted the various species of pines and spruces with clumps of evergreen shrubs, such as rhododendrons, kalmias, hollies, etc., makes the place look more home-like than where only deciduous trees and shrubs are planted. Care must be taken, however, not to make the house dark with too many evergreen trees, as then they give too somber an appearance during the summer. Whenever a great depth of snow falls it should be carefully dug away from around the lower branches of evergreens, as its weight is liable to break them and destroy the symmetry of the tree.

Shrubs as well as ornamental trees need painting and manuring the same as fruit trees, and if there is little or no snow on the ground the present is a good time to do this, as the turf will not be cut up by the wheelbarrow now that the ground is frozen.

Plants in pits will need attention during mild days. Apply water sparingly when dry, and give air whenever there is no danger of frost.

Hedges.—Prune during mild weather; at the South it can be done at any time during the winter.

Roots of cannas, dahlias, etc., must be looked after often, for fear they may become damp and rot. As soon as signs of mold appear remove to a dry place. A good place to preserve them is in the greenhouse, under the stages, where there is but little or no moisture.

Greenhouse and Window Plants.

During the winter months the aim should be to have the greenhouse looking its best, and in order to do this both plants and pots should be kept clean. Dead leaves will render an otherwise beautiful plant a shabby sight. Once or twice a week the plants should be looked over and these leaves removed; this, of course, can not be done in a large commercial greenhouse where plants are sold by the thousand, as the time occupied in doing it would be too expensive; but in a private house it can be easily done. Pots should never be allowed to become covered with green mold; this can be removed with a stiff brush and water slightly warm, at least if not left too long without washing. The temperature of the house should be kept at 50° or 60°, with an allowance of 15° between mid-day and night. This temperature is only applicable to a greenhouse. Stove and orchid houses require a greater degree of heat.

Succulents.—Within the past few years the

growth of succulent plants like sedums, echeverias, cactylodons, etc., has become popular, and there is nothing which makes a lawn so beautiful as a raised bed planted with the different species of succulents arranged in bands or ribbons. These plants require the protection of a greenhouse during the winter, and without a little care in watering there is danger of losing many through damping off. A shelf at the rear of the greenhouse is a suitable place in which to keep them. They should be watered sparingly. Many varieties may be propagated, as they root readily in sand that is kept constantly moist.

Propagation of geraniums and other soft-wooded plants may be carried on at this season in order to secure a stock for spring planting or for sale.

Camellias and Azaleas now in bloom require plenty of water. Those not in flower should be watered sparingly in order to retard their blooms. After they have flowered prune into shape.

Seeds of annuals for early spring flowering may be sown at intervals, and as soon as an inch or two in height may be potted singly into small pots or shallow boxes.

Plants for Forcing may be brought into heat now and will soon show signs of flowering. Astilbe Japonica, Deutzia gracilis, etc., are good plants for forcing.

Plants which look yellow and sickly will often succeed well if repotted into good soil, first cutting the roots and branches back a third at least.

Bulbs.—Bring a few pots of hyacinths, crocuses, and other bulbs which were potted in the fall from the cellar to flower during the winter. Bulbs which have already flowered should be gradually dried off and planted in an out of the way place in the garden when the ground opens, as it will be several years before they will flower well again, as the process of flowering greatly exhausts them.

Commercial Matters—Market Prices.

The following condensed, comprehensive tables, carefully prepared specially for the American Agriculturist, from our daily record during the year, show at a glance the transactions for the month ending Dec. 13th, 1873, and for the corresponding month last year.

Table with 4 columns: RECEIPTS, SALES, Comparison with same period at this time last year, Stock of grain in store at New York. Rows include Flour, Wheat, Corn, Rye, Barley, Oats, and various other commodities.

Gold has been up to 109 1/2—closing December 12th at 109 1/2 as against 108 3/4 on November 13th. The business situation has changed very decidedly for the better since our last. The Money market has been working much more satisfactorily for the borrowing interests. There have been fewer reports of trouble in financial and commercial circles; transactions have been on more extensive scale, and values have very generally advanced. The Produce trade has shown a marked improvement in most lines. Breadstuffs have been in more confident demand, in good part for export and on speculative account, and prices have been quoted much higher, closing buoyantly. The very sudden and unusually early closing of canal navigation has had the effect of diminishing the supplies arriving at the seaboard and stiffening the views of holders. Large amounts of Grain have been locked up in boats which are ice-bound on the canals, and the absence of which has been seriously felt in the local market. Exporters have experienced considerable diffi-

culty in filling orders for the better qualities of Spring Wheat and of mixed Corn, even at the ruling figures. We are entering on the winter months with very moderate stocks available at this point. Provisions and Cotton have been in better request, and quoted dearer. The recent dealings in Wool have been unusually liberal, and prices have been quoted higher, closing in favor of sellers. Desirable lots of fleece have been comparatively scarce in most of the Eastern markets. Tobacco has been in moderate demand, at steady rates. Hay, Straw, and Seed have been held more firmly and have been more sought after. Hops have been quoted lower, on a moderate trade, but close more steadily. On the whole, we can safely say that the financial panic has measurably subsided. Commercial affairs have recovered quite encouragingly from the depression caused by the extraordinary financial disturbances of September and October; and the outlook at present is far more satisfactory and inspiring than could have been reasonably anticipated a month ago. Work has been very generally resumed in the manufacturing districts, and there is now much less of apprehension as to the immediate future of industrial interests.

CURRENT WHOLESALE PRICES.

Table with 3 columns: Nov. 13, Dec. 12. Rows include Price of Gold, Flour, Wheat, Corn, Rye, Barley, Oats, Hay, Straw, Cotton, Hops, Feathers, Seed, Timothy, Flax, Sugar, Molasses, New Orleans, Coffee, Tobacco, Wool, Domestic, California, Alfalfa, Pork, Beef, Lard, Butter, Cheese, Beans, Peas, Eggs, Poultry, Game, Rabbits, Turnips, Cabbages, Onions, Potatoes, Sweet Potatoes, Carrots, Cauliflowers, Broccoli, Apples, Cranberries, Peas, Grapes, Quinces, Beets, Egg-Plants, Tomatoes, Green Peas, Green-Corn, Lima Beans.

New York Live-Stock Markets.

Table with 2 columns: RECEIPTS, WEEK ENDING. Rows include Receipts, and weekly ending data for Beesves, Cows, Calves, Sheep, Swine, Total.

various ups and downs, the market on the whole has improved, and at the close of the past week stood fully 1 1/2 c. above the average of a month previously. Choice steers, in selected lots, were sold at the close at 13c. @ 13 1/2 c. @ 14c.; good Ohio steers brought 12 1/2 c.; native cattle from 10 1/2 c. @ 12c.; and Texas and Cherokee 8c. @ 10c. Prices for the past four weeks were:

Table with 4 columns: WEEK ENDING, Range, Large Sales, Aver. Rows include November 17, November 24, November 24, December 1, December 8.

Milk Cows.—The supply has about met the moderate demand; there has been no activity, and sales have been made at from \$40 @ \$30 per head. A fresh 20-quart cow sold last week at \$75. Calves.—Grass calves have arrived in lessened supply, and the market for them, as well as for veals, has partaken of the general advance. Grassers of good smooth quality were selling at the close at \$7.50 @ \$9.50 per head, and veals were bringing 7c. @ 12c. per lb. Sheep and Lambs.—Sheep and lambs now rate evenly. The lessened supply, with active demand, has caused them to move off freely, with advance in prices. At the close sales were active, at 5c. @ 7c. for sheep and 6 1/2 c. @ 7 1/2 c. per lb. for extra lambs. Swine.—The market for hogs is in better condition. In the fore part of the month prices gained over one cent per pound, and at the close the advance has amounted to quite half a cent more. Live hogs sold at 4 1/2 c. @ 5 1/2 c. per lb., and dressed, with light pigs included, brought, with slow sales, 6c. @ 7c. per lb.

FREE—Fine Gold Pens, with Silver Cases—The Best Silver-plated Table Articles—Table Cutlery—Children's Carriages and Toys—Floral Sets—Garden Seeds and Flower Bulbs—Sewing Machines—Washing Machines and Wringers—Pocket Knives—Fine Gold and Silver Watches—Melodeons—Pianos—Guns and Rifles—Cultivators—Books—etc., etc., etc.; all these are among the valuable articles to be found in the Premium List on pages 33 and 34. Any person can, with a little effort, secure one or more of these valuable articles. Thousands have done it. There is room for thousands more. It is very easy to obtain clubs of subscribers for the two popular papers, the American Agriculturist and HEARTH AND HOME. Try it.



containing a great variety of items, including many good Hints and Suggestions which we throw into smaller type and condensed form, for want of space elsewhere.

Remitting Money:—Checks on New York City Banks or Bankers are best for large sums; make payable to the order of Orange Judd Company. Post-Office Money Orders for \$50 or less, are cheap and safe also. When these are not obtainable, register letters, affixing stamps for postage and registry; put in the money and seal the letter in the presence of the postmaster, and take his receipt for it. Money sent in the above three methods is safe against loss.

Postage: On American Agriculturist, 12 cents a year, and on Hearth and Home, 20 cents a year, in advance. Double rates if not paid in advance at the office where the papers are received. For subscribers in British America, the postage, as above, must be sent to this office, with the subscription, for prepayment here. Also 20 cents for delivery of Hearth and Home and 12 cents for delivery of American Agriculturist in New York City.

Bound Copies of Volume Thirty-two are now ready. Price, \$2, at our office; or \$2.50 each, if sent by mail. Any of the last seventeen volumes (16 to 32) will also be forwarded at same price. Sets of numbers sent to our office will be neatly bound in our regular style, at 75 cents per vol. (50 cents extra, if returned by mail.) Missing numbers supplied at 12 cents each.

Clubs can at any time be increased by remitting for each addition the price paid by the original members; or a small club may be increased to a larger one; thus;

a person having sent 10 subscribers and \$12, may afterward send 10 more subscribers with only \$8; making a club of 20 at \$1 each; and so of the other club rates.

Once More we place upon our shelves a bound volume of the *Agriculturist* by the side of the godly array of its predecessors; and while the majority of our readers are occupied with the last number for 1873, we are preparing to send them the first number of 1874. To our old friends we need only say that the paper shall be as much better than it has been as it is possible for us to make it. To those who now first become acquainted with us, we can say that we endeavor to present such a bill of fare as will be acceptable to those who are to partake of it, and we invite them to make their wishes known to us. Our correspondence comes not only from every portion of our own country but from all parts of the world. A record is made of the subject of each letter, and at proper times these are classified, so that we are able to see at a glance what our readers are thinking about and what are their most urgent needs. Feeling that every family—at least every one in rural life—would find the *Agriculturist* not only interesting but useful, we call attention to the business announcements of the publishers on pages 32 and 33. Long experience has shown that their manner of giving premiums enables them to give those who interest themselves in extending our circulation much better pay for their time and labor than they otherwise could. There is no way in which farmers or farmers' clubs and granges can supply themselves with libraries or obtain many other desirable articles so readily as by obtaining subscribers for the *Agriculturist*.

The "Basket," which is always full, has now overrun; and though a portion of its contents will be found on page 35, we have not been able to answer all the queries of our friends. Some must wait.

The German Agriculturist is published at the same price as the English edition, and is mainly a reproduction of that paper, with a special department edited by the Hon. F. Münch. Will our readers kindly mention this to their German friends? Perhaps some who employ Germans as gardeners, laborers, etc., would be glad to supply them with useful reading matter by subscribing for the German edition for them.

State Granges.—Upon the 10th of last month two very important meetings of the Patrons of Husbandry were held—the State Grange of Illinois, at Bloomington, and that of Iowa, at Des Moines. Both were well attended, some seven hundred delegates being present at Bloomington and a correspondingly large number at Des Moines. The addresses of the Masters at both Granges were full of good sense, and had reference, among other matters, to the action of the order in politics. The course of some subordinate orders in political matters was disapproved. As we learn from conversation and correspondence with some of the most prominent men in the order, they do not propose, as a body, to take a part in politics, but, just as the members of a church will vote for candidates who they suppose are not adverse to religious progress, so the members of the granges will vote as individuals for those candidates who will best advance the interests of the farmers. This position being known, it led in California, recently, to both parties presenting unusually good candidates.

Othonna—Correction.—Last month we gave an engraving of this promising new succulent, which was a correct representation of everything except the flowers. Except in bright sunshine the ray petals curl up as shown in the engraving, and the artist drew them as he saw them. We should have directed him to draw them with the rays spread flat, like those of an Ox-eye Daisy.

English Farm Labor for America.—The visit of Mr. Joseph Arch to this country has awakened a new interest in the introduction of English farm laborers. Several have written to us in regard to those who advertise their readiness to provide laborers under the auspices of Mr. Arch and the association he represents. In an interview with Mr. Arch shortly before he returned to England, he distinctly assured us that he should in no case treat with individuals, but only with governments and organized societies of known responsibility. He was so positive upon this point that it is difficult to believe that he has "gone back" upon himself and authorized unknown persons to act with his authority. If he has done this, then he is not so well fitted to represent the laboring class as his previous course gave us reason to believe him to be. Pending definite information on this matter, we advise no one to risk a dollar upon a venture, but be sure that he has some security that his money will be properly used. The sum asked in advance—\$5—is so ridiculously inadequate to

bring out a man from England, that with our present knowledge we look upon the whole matter with suspicion. A gentleman of our acquaintance has made persistent efforts to see one of the persons who advertises to bring out English laborers, and gone from hotel to boarding-house so often in vain that it looks—so far as this person is concerned—as if he were avoiding rather than seeking business. "Wait a bit" is a good motto to adopt in this matter.

Our Fine Chromos.—Read all about them on page 32. It is very easy to secure one or both.

Take Both Papers.—If both the *American Agriculturist* and *HEARTH AND HOME* are taken together they may be had for only \$4, and \$4.50 pays for both papers and a Chromo with each.

Only Ten Cents.—We advise every reader of the *American Agriculturist* who does not now take *HEARTH AND HOME* to get No. 1 for January 3d, 1874. It contains a supplement with the opening chapters of Mrs. Rebecca Harding Davis's great new story, "John Andross," and is filled with other good things. Get it of your newsdealer, or send a dime to this office, and a copy will be forwarded post-paid.

The Garden Library.—Our friend Robinson, editor of *The Garden* (England), has established what he calls the Garden Library, for the sale of new and second-hand books upon horticulture and kindred subjects. A neat catalogue, giving the works for sale and prices, can be had by addressing *The Garden Library*, No. 37 Southampton street, Covent Garden, London, W. C., England.

Farms for Premiums.—A most liberal offer of farm lands as Special Premiums is made by the Publishers to those who will secure clubs of subscribers for the *American Agriculturist* and *HEARTH AND HOME*. See particulars on third-cover page of this paper.

Do Not Fail to Read it.—The Premium List on page 33 of this paper is worthy of the attention of everybody who would like to do good and at the same time make money. Thousands of persons in years past, not only in all parts of this country, but also in British America and in other parts of the world, have each obtained one or more of these valuable premium articles by simply collecting a list of subscribers and forwarding them, with their subscriptions, to the publishers. Do not fail to read the Premium List.

Illustrated Register of Rural Affairs for 1874. Albany: Luther Tucker & Son. —If we do not always notice the appearance of this useful annual it is because the publishers fail to send an editorial copy. It is sufficient praise for this number to say that it is worthy to stand by the side of its predecessors. We do not know where more can be had for the money—30c, for which sum it is sent by mail from this office.

A Fine Catalogue of a Fine Library is that of the Massachusetts Horticultural Society, recently issued. The library is rich in new and old books relating to horticulture, and its treasures are always accessible to those interested in consulting it. Here is one library at least in the care of those who desire to make it useful, and the Massachusetts Society deserve great credit not only for accumulating such a fine collection of books, but for publishing a complete catalogue which gives not only subjects but authors in a manner for ready reference. Horticulturists visiting Boston should not fail to see this library, and if they do not find the veteran Buswell at the rooms ready to serve them they will find his place filled by his wife or son, either of whom are always ready to make a stranger welcome.

Much Castor-Oil.—A writer in the *Kansas Farmer* says: "Scientific writers inform us that there are no less than 1,500 species of the Castor-oil plant."—We do not know to what "scientific writers" this correspondent has access, but the standard botanical work of the age, De Candolle's *Prodromus*, puts up the whole number of species of *Ricinus* or Castor-oil plant, and makes—*just one!* We may add that he recognizes sixteen varieties of this species.

The English of It.—French names for fruits when they come into common use by English-speaking people, sometimes become curiously transformed. The *Gardeners' Chronicle* tells us that the pear Josephine de Malines is known in England as Joseph on the Palings. We can nearly equal that on Broadway,

where a vender placards his "Dan Jo," pears, this being his rendering of Beurré d'Anjou.

SUNDRY HUMBUGS.—If one were to sit at the window of this office and watch the passers on Broadway he would notice that among the hundreds and thousands who go by, some faces will reappear at short intervals. When his eye becomes accustomed to the crowd he will observe that certain men, either singly or in pairs, pass up and soon after go down the street, seeming to have no particular destination. These persons are not especially noticeable in the matter of dress, but the observer will find something not altogether pleasant in their faces, and if he inquires about them of some one familiar with the street he will learn that they are known as "strikers," "beats," and by other slang names, and that their business is to prey upon

STRANGERS IN NEW YORK.

The manner in which they operate can be illustrated by a bit of personal experience. A few evenings ago as the writer of this was hurrying to the boat in order to go to his home in the country, he was accosted by a person who was coming rapidly towards him with outstretched hand and countenance expressive of gratification with: "Well, well, of all things in the world! Why who in — would have thought of meeting you here! When did you get in?"—"I do not know you, sir, who are you?" was the reply. "What! Don't you recollect Dr. Norton?" he said, and seeing the kind of chap we had to deal with, we humored him a little, and instead of denying all knowledge of the "Doctor," we asked: "Well, Doctor, how is practice?"—"Oh I am not practising now; I'm in business."—"Business eh? what kind?"—"I am selling off a fine lot of jewelry and watches cheap; it is close by here, come along and see them." The Doctor was informed that New York had been our place of business for some 20 years, and that his little game would not work. There is a gang of scoundrels who infest the much traveled streets and make up to strangers in this barefaced manner, and too often succeed in fleecing them. The police when they see that one of these rogues has a victim in tow inform the stranger of the character of his companion. This is all they can do, as they can not make an arrest unless some misdemeanor is actually committed. Almost every one comes to New York sometime or another, and we must warn all who visit this or any other large city to repel the approaches of any stranger, no matter under what pretext he forces himself upon them. Do not even inquire the way to a place or ask any other information of a stranger upon the street, but always apply to a policeman, or if one is not readily found step into a respectable looking store and make the necessary inquiries.

SUSPICIOUS LIVE-STOCK DEALERS.

We have before mentioned that numerous complaints have been made of certain dealers in live stock in Pennsylvania, and letters continue to come relating transactions which, as they are represented by one of the parties, appear to be nothing less than downright swindles. The gentlemen who complain have sufficient means to forward pay for high priced animals; why do they not bring these alleged swindlers into court? The latest letter received in relation to this matter comes from a postmaster in New Mexico, and we give an extract from it to show the general tenor of the charges against the firm: "In Feb. last I sent to — & Co., of P—g, Pa., for fine chickens. I sent them a draft for \$26, and as yet have got nothing from them, only they acknowledged the receipt of the money. Then they wrote me that the Express Co. would not take them unless the charges were prepaid, and that I should send them so much (the amount of Ex. charges) and they would ship. I then mistrusted them, and wrote to pay express charges out of the money I sent them, and send chickens for the balance as per my letter. That seemed to be a deadener on them, and from that time I get no reply whatever." The writer of this letter asks if we do not think this firm ought to be exposed. We certainly do, and the best way to expose them is to bring a criminal suit against them for obtaining money under false pretenses.

THE PANIC AND HUMBUGS

seem to have a relation to one another, as while we usually have a lively opening for the winter trade we never knew matters so dull as at present. The newer States and Territories are especially favored by the humbug chaps. One gentleman living in Colorado sends us no less than nine circulars of different schemes, which he had received within a short time. . . . Those who wish to get rich quickly might invest in the

GOLDEN BUTTER COMPOUND.

This time the butter stuff hails from Mariou, Ohio. What is the use of Alderney cows when with this stuff butter can be made for "three cents a pound." We can afford to butter our bread on both sides. Those chaps in New York who make "butter" out of tallow have to kill a

cow before they can get any butter, but if we are to believe the story this "Golden Butter Compound" only needs a live calf—to purchase the stuff. It is curious to see how this butter humbug comes up about once a year now in one place and now in another, and yet there are some stupid old fogies who will keep cows and think them the proper source of butter. . . . Here comes one J. W. Stephens who hails from Newark, N. J., with his

CLARK'S BOOK OF SECRETS,

which teaches "the Secrets of Health, Wealth, and Happiness"—and must be singularly cheap at only \$1. See here, Stephens, you say that this book "Teaches how the Primitive Elements may be so combined as to produce the diamond, ruby, emerald, sapphire at very little expense or trouble." Now you are at more than "a little expense" in printing your book, and at lots of "trouble" in sending out your humbugging circulars. Why don't you, like a sensible man, just make a small handful of diamonds, or even emeralds, and get a fortune in a lump instead of by miserable dribbles. Take our advice, Oh Stephens, for which we charge you nothing. Don't you laugh when you read that your book tells "How to Make a Girl Fall in Love With You," to think that there will be miserable idiots to buy your book and believe it? Here comes some

GOOD NEWS FROM KANSAS.

Before this reaches our readers there will have been drawn (Dec. 31st), if the programme is carried out, a lottery under the name of "Grand Gift Concert" at the City of Leavenworth. This lottery is "For the Purpose of Erecting a Juvenile Reform School." We say that this is good news, for the fact that a huge lottery is on foot in Leavenworth shows a great need of reform, and as the present authorities, by their lottery gambling, are setting a fearful example to the rising generation, we are glad to learn that the youth of Leavenworth are to have a place where they can be "reformed."

DOES IT NOT LOOK SUSPICIOUS?

writes a correspondent in sending us the advertisement of The Fourth Lottery or "Gift Concert for the Benefit of the Public Library of Kentucky." Yes, good sir, it does "look suspicious," and so does every scheme of its kind. Every sensible man knows that every lottery, no matter how fairly conducted, enriches a few at the expense of many. This is "about the size of it" as they say in California: One hundred men put in a dollar each that one man may draw \$25, and the chap that runs the machine may pocket the odd \$75. So with the "U. S. Prize Association" and everything of the kind.

GENEVA \$4 WATCHES

are still to be had—or perhaps it would be safer to say—are still offered. Is it not a little funny that the "Geneva Watch Co. of Geneva, Switzerland," whatever that may be, should issue a certificate that they have appointed J. Wright & Co. [N. Y.] "our sole agents in the United States of America," and that they have appointed Howard & Co. [Phila.] "our sole agents in the United States of America," and that both certificates bear the same dates?

COUNTERFEIT MONEY OR "QUEER"

seems to be very dull. One would think that this thing would do better in time of panic, but as the swindlers always require good money in exchange for their bad, perhaps the times induce those who happen to have the genuine to hold on to it. We showed up the hotel dodge of the "Queer" dealers in the November number. These circulars are still going around with much the same old names. . . . Here is one new name, however, Rudolph A. Malataf, Erie, Pa., but as Rudolph sends the same old threatening circular, and mails it at New York, he is only "Mons. Tonson come again." Rudolph makes a mistake when he sends his temptations to our friends in the nursery and florist's business; they read the *Agriculturist*, and know "what's what."

ONCE MORE—PLEASE TAKE NOTICE.

We again call the attention of our old readers to one thing, which we give for the benefit of our many new ones as well, which is this: We hold that any one who advertises that he can cure certain complaints, or who advertises anything beyond the fact that he is a physician or surgeon, or who advertises any put up secret medicine whatever, is unworthy of confidence. We must therefore request of our friends that they will not write to ask our opinion of this or that advertising doctor. It is a waste of our time and their postage stamps. We have but one reply to make to such inquiries, which is: "We have no knowledge whatever of the person."

Other "Basket" Items will be found on page 35.

The Taylor or Bullit Grape.—E. Mauny, Freeport, Ill., writes that his vines of this variety last season set unusually full, and that the grapes, instead of being white as they should be and were in

two previous crops, ripened of a black color and were very sour. These particular vines were not protected the preceding winter, and others of the same variety that were protected bore the usual kind of fruit.—We hope that Mr. M. will experiment this winter to ascertain if covering has anything to do with this singular phenomenon. The same writer remarks that while he considers the Taylor an indifferent grape, he finds it valuable for stocks upon which to graft other kinds, the Delaware doing especially well when so worked.

"Grape Tomato."—A correspondent, whose address we have mislaid, sends specimens of what he entitles as "grape tomato," and asks if the name is correct.—This name belongs to a small variety of the common tomato, and not to the one sent, which is the Purple Alkekengi, or Purple Ground Cherry.

Harvest Home Festivals.—"Viz.," Covedale, Ohio, informs us that the harvest home festival is not unknown in America, but that a harvest home association has been in existence in Covedale for ten years or more, the annual picnics of which have been found to be indispensable. The offer of our correspondent to send us a copy of the regulations of the association is accepted with thanks. The extended formation of such associations is to be encouraged.

See Pages 32 and 33.

White Spots.—"C. B.," Groton, N. H. A white spot may be made upon a horse's forehead by blistering the part with common blistering ointment, but it must not be done so severely as to destroy the hair. A plaster of common pitch kept upon the part until it removes the hair has been used for this purpose.

Pears.—"W. P.," Some pears were received last fall in very bad condition. They may have been yours; but your letter (November 15th) has neither town, State, nor post-mark, and no clue to your address.

Kentucky Blue-grass.—W. S. Rand, Vaneburg, Ky., sends us a sod of blue grass cut November 15th, upon which green, fresh grass, over two feet long, is growing. This is intended to show the sort of winter pasture which may be had in the famed blue-grass region of that State.

Capacity of Cistern.—"P. and G.," Wilson, N. C. A cistern 8 feet wide, 8 feet long, and 1½ deep, would hold 96 cubic feet, each cubic foot being equal to 7½ gallons of water; the contents therefore would be over 750 gallons. Upon another page of this number you will find a method described of building an elevated cistern. The best material is probably hemlock or cedar lumber. Lead is poisonous, and iron rusts too readily. Zinc is also poisonous to some extent.

The American Rural Home.

There are disappointed, soured persons calling themselves pomologists who carp and snarl at every new fruit that they have had no hand in introducing, and are ever ready to malign those who bring out a novelty. We do not wonder at this—it is their nature so to do; but we do wonder that a respectable paper should allow its columns to be made the medium through which these malcontents can reach the public. The American Rural Home publishes an article in which two of the correspondents of this paper and its editor are referred to in the most ungentlemanly manner. To the writer of this communication we have nothing to say—the lion's skin of an assumed name is not sufficient to conceal the thing beneath it; nor does the editor of this paper care to notice anything in reference to himself that comes from this source. Yet we think it right to remind the editor of the Rural Home that it is not in accordance with editorial courtesy to allow one under a pseudonym to attack two brethren of the press. Mr. P. J. Berkmans, editor of the Farmer and Gardener, named a new peach in honor of the editor of this paper, and furnished us with a description of it. The Rural Home should hesitate before it gives publicity to any aspersions upon the character of a gentleman who stands so high, pomologically and socially, as does Mr. Berkmans. Before it uttered flings at the honesty of his motives or implications as to his truthfulness it could have inquired of the many pomologists of Rochester if such were justified. Mr. B. can not be injured by its article, but in what a position it places the Rural Home. The same article is equally courteous towards Mr. Bury, of Michigan, whom we quoted as having a Concord grape that behaved strangely. It contemptuously says: "We don't know aught of the man Bury." The gentleman's name is Bury; but, Bury or Bury, he has cause to congratulate himself at this statement. Fair, open criticism, even if it be sharp, we believe in, and nowhere is it more useful than

in pomological matters; but if we must have this underhanded substitute for it we beg the Rural Home not to give us bad grammar with its bad taste.

Killing Weeds.—"R.," Sault St. Marie, Spading the garden in the fall, though beneficial in other respects, will not kill weeds. The seeds of weeds are not to be frozen out. The only way to get rid of weed seeds in the soil is to allow them to germinate, and then kill the young plants. If taken at the right time this may be done in the garden with the rake. Do not hope to destroy the vitality of weed seeds either by freezing or by burying; as soon as the influences are favorable they will grow as sure as fate.

A Good Native Cow.—F. M. Bassett, Independence, N. Y., writes us that a native cow gave in June last 1,600 lbs. of milk. The latest daily yield in the month was 57 lbs. 53 lbs., or one day's milk, was churned, and yielded 2 lbs. 1 oz. of butter. Her feed was pasture and 6 lbs. of wheat bran per day.

The Michigan State Pomological Society held its third annual meeting in the first week in December. It was stated that the signs (which almost always fail) indicated that the winter would be an open one; a mild winter was considered disadvantageous to fruit-growers, but what the Society propose to do about it is not stated. Prof. Cook stated that in the last disastrous winter orchards that had been cultivated fared worse than others; in the Grand Traverse region, where the snow is generally four feet deep, fruit culture was successful. Fruit near Kalamazoo had suffered from the drouths of summer. The often vexed question of the best and hardiest grape came up. Mr. Chilson, of Battle Creek, considered the Delaware the hardiest and most money making; the Diana the best keeper; approved of covering the vines with earth in winter, and that no grapes were hardy enough for Michigan without this protection; the Iona, though it often fails, he considered a standard variety. Mr. Sterling, of Monroe, advocated Concord and Norton's Virginia; he covers. In the Strawberry discussion the Wilson was the favorite.

Frequent Working.—"E. E. R.," asks if he can injure his soil by spading every year. No. Our market gardeners plow or spade two or three times a year, and we can point out land that has been kept "always turning," as they term it, for more than fifty years. They are careful, however, to put in some manure every time a crop is taken off, and if this be done the soil is practically inexhaustible.

Fruit near Chicago.—A gentleman who has experimented for six years considers the Green Prolific and Seneca Chief the most successful Strawberries with him, and Davidson's Thornless, Mammoth Cluster, and Golden Thornless the best Raspberries. These are all varieties of black-caps, and however well they may sell in Chicago, would find a poor market in New York.

Solvents for Gutta Serena and Caoutchouc.—"D. J. B.," Wash. Co., M. D. Purg ether, chloroform, and benzole, will each dissolve these substances. The last heard of the quack medicine vender was in Paris, where he was in an impecunious state.

Mushrooms.—"E. E. R.," The "spawn" is what corresponds to the roots and stems of other plants, the mushroom, or eatable part, is the portion of the plant which corresponds to the seeding portion. You will not be able to grow them in common garden beds. They need a bed of horse manure, and proper attention to shade and moisture.

Cotswolds.—"E. E. R.," These are among the largest breeds of sheep. If your ram is small he must be a grade.

The Scotch Larch.—"G. C.," New Jersey. The larches are not evergreens, nor are their branches sufficiently rigid to make them useful as hedge plants, therefore your other questions need not be answered.

Ashes.—A correspondent asks if ashes from a stove will be of use upon his garden, but does not say what he burns in his stove. Wood ashes are good for almost all crops; coal ashes had better be used for walks unless in very stiff land, where they may be of mechanical service.

Swollen Neck.—"L. A.," Fountain Green, U. T. The cause of a swollen neck is almost always a badly fitting collar. If a snugly fitting collar is provided the swelling often disappears without any other remedy; if not it must have time to break, discharge, and heal.

Beef from Texas.—Ten cars of fresh beef have recently arrived in New York from Denison, Texas. The cars are the patent refrigerator cars of Mr. T. L. Rankin, of Emporia, Kansas. They contained 420 carcasses of beef, which were slaughtered in Denison and Anstlu, Texas, on the 26th November, and arrived in perfect order in New York on the 6th of December, when they were sold. The running time was only five days from Denison. The results of this successful trip are that beef is brought to the New York market in a perfect condition, free from bruises and unwholesomeness contingent upon the carriage of live stock in the railroad cars, and sold at a less price, with a greater profit, to the cattle feeder, the shipper, and the transportation companies. It is expected that 500 head will be sent three times each week in future from Denison to New York. By the use of these cars much suffering will be saved to the cattle, and their ultimate destination will be reached in a much less painful manner than otherwise.

Beacon Comet Stb.—This bull, of which a portrait is given elsewhere, is nearly four years old, having been dropped February, 1870. His color is mulberry fawn. He was bred by Mr. Crozier, being out of his imported cow Josephine, by Beacon Comet. He was one of the Jersey herd exhibited at the New York State Fair of 1872, to which the gold medal was awarded.

See Page 35 for other "Basket" items.

What Shall we Have for Breakfast?—The answers to this question were unexpectedly numerous, no less than 237 having been received. Some of these were simply bills of fare without any comment, while others contained useful suggestions and recipes. To reduce this mass down to forty or fifty of the best was an easy matter, but to say which was the best one, or best three of this smaller number, was exceedingly difficult. Then again, those living near the coast naturally propose quite different articles from those living far inland, and a Southern housekeeper's list of articles quite different from that of her New England sister. As the most satisfactory way of awarding the premiums, we divided the contributions geographically, awarding a premium to the best from each of the divisions, New England, Middle, Western, Southern, and Pacific States, as follows: Mrs. Thomas S. Robie, New Ipswich, N. H.; Miss J. J. O., Woodbourne, Sullivan Co., N. Y.; Mrs. Allen G. Bonham, Oxford, Ohio; Mrs. Anna Tanner, Evergreen, La.; Mrs. G. H. Kellogg, Crescent City, Cal. Some of these bills of fare, with their accompanying recipes, will be published in the Household in future numbers, and there is much that is useful in many of the articles which did not receive the premiums.

Ithaca Horse Rake.—"C. W. D.," Guilford, Ct. The Ithaca Horse Rake is made by the Wheeler and Melick Co., Albany, N. Y.

Swelling of the Legs.—Dr. "H. A.," Columbia Co., Wis. When the legs of a horse swell upon standing in the stable it is an evidence of debility, general or local. It would be well to increase the food in quantity or improve its quality. The following might also be of use—viz.: Powdered sulphate of iron, 1½ oz.; gentian root, 2 oz.; chlorate of potassa, 1 oz.; mixed and divided into 12 powders. One of these given in cnt feed as little moistened as possible night and morning. Ground oats would be better for feed than corn. Friction by rubbing with a coarse woolen cloth upon the parts would also be helpful.

Naked Brahma Chicks.—"C. F.," Detroit, Mich. It is not at all uncommon for young Brahma chicks to be almost without either down or feathers. Eventually, however, the feathers make their appearance. Fowls of this breed are very hardy, and the want of feathers does them no injury except in appearance. Partially web feet are a monstrosity which we have occasionally seen in fowls. Such fowls should not be bred from.

Indigestion in the Horse.—"J. H. T.," Philadelphia, recommends pulverized charcoal for indigestion in a horse, to be given in the food. Also rasping the teeth of old horses in cases where the center of the tooth has worn below the outer enamel, and has left the teeth cup shaped. J. H. T. however forgets that horses' teeth do not wear in this way, but that, through a beautiful contrivance, the enamel as the tooth wears away is left in the shape of an irregularly curved and angular ridge, which forms a very perfect grinding or cutting edge, and except in very old horses these grinders are the last teeth to give out.

See Pages 32 and 33.

Value of a Cow.—"J. P. L.," Ringwood, N. C. A cow that gives 20 quarts of rich milk per day should bring the highest price current for cows in her particular locality. Prices depend very much upon locality. A cow of that character would bring \$70 in some places, in other places not more than \$40.

Gregory's Specialties.—We always like to see a man ride hobbies, especially when they are good ones. Our friend J. J. H. Gregory, of Marblehead, Mass., has always some special things in the way of garden seeds, which he makes a specialty of, although he does not neglect the standard varieties. If he had never had any other hobby than the Hubbard Squash, he would deserve well of the community, but when we take into account the other squashes, the cabbages, beans, sweet corn, melons, and we can not remember how many other things that he was the first to bring prominently before the public, we are quite sure that the gardens all over the country are largely indebted to Mr. Gregory for many of their choicest products.

Poultry upon a Large Scale.—"F. W. J.," Quincy, Ill. Poultry-raising upon a large scale has not been generally successful. It has only been profitable when carried on by experienced persons, and the business has grown from small proportions gradually larger and larger. To commence a large poultry business even with abundant capital but without experience would be one of the most hopeless of undertakings. The series of articles upon an egg farm which appeared in the *Agriculturist* in the latter part of 1871 and early part of 1872, contains a great deal of valuable information by an experienced poultry raiser.

Fertilizers upon Oats.—"Inquirer," Danville, Va. Soluble fertilizers should be kept upon the surface and not plowed into the soil. Oats may be plowed in and the fertilizer should afterwards be evenly sown upon the surface, or the seed and fertilizer may be harrowed in together.

Clover Sod for Wheat.—"B. W. B.," Christian Co., Ill. Clover sod broken last fall will do very well for spring wheat, but it should not be cross-plowed. The sod will not be sufficiently rotted to turn over. A good harrowing will fit the ground for sowing.

A Homesteader in Minnesota.—"C. T. Clough, Wilmar, Kandiyohi Co., Minn.," writes us that he and his brother took up homesteads in the central part of Minnesota four years ago, which has been rapidly settling up since then. He found the soil rich and the climate healthy. He has now 45 acres under crops, and raised last year 400 bushels spring wheat upon 20 acres, 600 bushels oats upon 15 acres, 75 bushels of potatoes upon a quarter of an acre, and 300 bushels of ruta-hagas upon another quarter. He does his plowing with two ox-teams. He has also 24 acres of Odessa wheat sown this fall. He has planted 5 acres with timber—oak, maple, ash, willow, and cottonwood. The willow is very successful as a hedge plant. Timber grows very rapidly and fire-wood will soon be plentiful at his door.

Management of Manure.—"C. K.," Pittsylvania Co., Va. The only way to rot manure in the winter is by frequent turning with repeated fermentation and guarded heatings. In this way it may be brought to a fine condition for use in the spring. Long corn-stalks can not be rotted by this process, and by no means should such corn stalks be allowed in the manure pile. It is preferable to cut them when fed, as in that state the refuse is more easily rotted, and if not rotted is no trouble when the manure is turned over.

Harrowing Wheat and Young Timothy.—"T. P. B.," Christian Co., Ky. We never spring-harrowed wheat with which timothy had been sown, and should fear injury to the timothy by doing so. The wheat being well rooted will stand the harrowing, but the young timothy would probably suffer. Since we made a practice of harrowing wheat in spring we always sowed the timothy and clover at that time, and found the grass equally as good if not better than the fall sown.

Sheep in New Mexico.—We are favored by a correspondent from Puchlo, Col., with a long communication, exceedingly rich in figures, by which it is shown that 5,000 Mexican ewes and 100 rams will in ten years increase to 591,102 sheep of a value of \$886,916.30, also that the value of the wool product of this nice little flock will be in the 10 years \$842,416.30; the total product of this pastoral business therefore, is nearly a million and three quarter dollars, of which the clear profit is figured up to the respectable sum of over one million dollars, the odd figures being generously thrown away,

That this result *might* happen figures are abundantly able to show, that it *would* happen depends upon contingencies so certainly uncertain that it is wise to avoid them. Ever since the days of Virgil's shepherds, sheep have been "always an unhappy flock," and with the best of care they will turn out so even now. Let no one try to keep a large flock of sheep without abundant previous experience.

See Pages 32 and 33.

George A. Prince & Co.'s Organs and Melodeons.—The musical instruments that come from this old and well-known house have attained a world-wide and well-deserved popularity. Their instruments include a great variety of styles and sizes adapted to use in parlors, halls, and churches. In richness of tone and quality of manufacture they are unsurpassed, some of their instruments, to our personal knowledge, having been in use for many years without needing any repairs. The many organs and melodeons from this house which have been given by us as premiums have been received in every case with great satisfaction. When musical instruments are wanted, get *good ones or get none.*

How to Get a Homestead.—"W. M.," Oneida Co., N. Y. Homesteads are still plentiful across the Missouri, but are scarce upon this side of that river; although there are some yet remaining in Western Iowa and Minnesota. But in Nebraska and Kansas, a short distance back from the railroads, there are thousands of locations remaining to be taken up. The mode of proceeding is to go to the locality desired, and at every town or railroad depot parties are on hand who will give all the necessary information as to the exact position of vacant lands. When the lot is selected, which is 160 acres for a U. S. soldier or sailor, and 80 acres for others, within 10 miles of the railroad line or within the limits of their grant, an application is filed in the U. S. land office. If the homesteader is living upon the land at the time of filing of the application, this may be done at the office of the clerk of the county in which the land lies. He must then enter into absolute occupation within six months and commence to improve his land. After five years' residence he may claim a deed in fee by payment of certain fees amounting to about \$18. The time of a soldier's service in the army is deducted from the five years' residence required for others.

The American Dairymen's Association will hold its Ninth Annual Meeting at Utica, N. Y., on January 13th to 15th. Hon. Horatio Seymour, X. A. Willard and other well-known writers will read papers at the meeting. L. B. Arnold, Rochester, N. Y., is Secretary.

Prevention of Catarrh in Sheep.—"W. J. E.," Birmingham, Ala. A damp, low spot should not be chosen for a sheep-shed. Raising the floor ten inches from the ground will be no preventive of the danger of catarrh. It is breathing the moist, cold air as much as actual contact with the damp soil that affects the sheep. A location perfectly dry and well drained should be chosen.

Change of Seed.—"J. B. S.," Concord, Tenn. With all other grains than corn a change of seed now and then is considered advisable. Potatoes are especially improved by a change procured from a different locality and soil. But corn has not generally been found to deteriorate by long planting; on the other hand there are many farmers who are now planting seed produced from the corn their fathers planted a generation ago. Running out of the corn is more likely to be the result of impoverished soil, and the best method of improvement would probably be a crop of clover upon the land, to be plowed under, or some other substantial fertilizer.

Bone-Dust upon New Land.—"H. D.," Earlham, Iowa. It will hardly pay to put bone-dust upon new prairie land, even could it be bought at \$5 a ton, which price we feel sure there is some mistake about. Bone-dust is more particularly useful for root crops, but pastures are much improved by it. Its effects are not always immediately apparent, but they are afterwards often visible for many years.

Peas and Oats.—"H. D.," and others. Peas and oats, when sown together, can not be separated in thrashing so as to make each grain marketable separately; for feed this is unnecessary. When ground together the oats reduce the highly stimulating effects of the peas. In seeding 2½ bushels of oats and 1½ of peas may be used. The seed should be drilled or plowed in if possible, as it is difficult to cover peas with the harrow.

Instruction in Horse-shoeing.—“L. S.,” Champaign Co., Ill. It is impossible to learn from books how to shoe a horse. One may learn how it should be done, but to do it requires practice. It is a very simple thing and easily learned; and every farmer should know how to do it. He may save many dollars and much time by possessing such knowledge. The Goodenough Horse-shoe Company will send a competent teacher of the art to any part of the country, in which 100 pupils, at \$3 each, can be procured, who will teach each one to shoe a horse and take care of the feet. The Granges can do no better work than in this way to have all their members properly instructed in this art, the proper care of the feet and methods of treating simple foot complaints.

Grain Drills.—“H. M. W.,” Portage Co., Ohio. We have not experimented with any seed drill sowing less than eight inches between the rows. What difference in the yield would result from making the drills seven inches apart we can not say, but the yield would probably be less than if the drills were made nine inches apart. We think nine inches the best space for drills for wheat or rye. If the crop so drilled were cultivated in the spring, there is no question of its consequent improvement.

Cure for Curb.—“D. M. H.,” Oswego, N. Y. Curb consists of a swelling immediately below the hock and at the back of the leg, upon the back sinew. It is the result of a strain or of inflammation, and is not necessarily a cause of lameness any more than a windgall, thoroughpin, or bog spavin, to all of which it bears a close relationship, except as to locality. The treatment is to rub the part with ointment of binoidide of mercury, as much as the size of a hickory nut every sixth day.

Pickle for Sugar-Cured Hams.—“Subscriber.” A very common pickle for hams is made by dissolving one pound of coarse salt with four ounces of sugar in as little water as possible (sugar-house syrup may be substituted for the sugar). This pickle is boiled, skimmed, and poured, when cold, over the hams already well rubbed with salt and packed in a barrel.

See Pages 32 and 33.

Gale's Copper-Strip Cutter.—The machine manufactured by Warren Gale, of Chicopee Falls, Mass., is the “Gale's Copper-Strip Feed Cutter,” which we have often recommended as being an excellent feed cutter.

Knitting Machine.—“J. W.,” Brown Co., Ohio. The Bickford Knitting Machine, price \$25, is considered a very good one for family use. All the knitting machines require to be used with care, and some amount of mechanical skill is needed to run them successfully. They are not so easy to run properly as a sewing machine.

Petroleum for Shingles.—“G. W. K.,” McKinney, Texas. Crude petroleum would not make a proper coating for a pine shingle roof. The roof is the part of a house most exposed to fire, and is sufficiently inflammable without soaking with petroleum. A good pine shingle roof, well laid, hardly needs any coating to preserve it, as it will last as long as an ordinary frame house. If any coating is desired, and the water from the roof is not to be preserved, gas-tar or any of the oxide of iron paints, generally known as the fireproof metallic paints, are the best coatings. Crude petroleum is very cheap, and one barrel, worth about \$5, should cover the buildings of a moderate sized farm.

Ground Bone.—“J. J. L.,” Crisfield, Md. Ground bone is a good application for almost any crop. For wheat, 500 lbs. per acre might be spread in the spring and harrowed in with a light harrow or a bush. 200 pounds of guano, however, would doubtless have a better effect upon the wheat.

Broom Machinery.—“T. S.,” Clinton, La., and many others, are referred to W. J. Brooker, Fort Plain, Montgomery, N. Y., for the information they desire as to broom-making machinery.

Epizootic and its Results.—“E. H. McC.,” Lee Co., Iowa. The epizootic, which so generally affected horses over the whole country last year, often leaves as its effects a chronic cough and a running at the nose. Besides, the complaint itself is very likely to return upon exposure to cold. It is very difficult to cure the cough and nasal discharge, which are the effects of a sort of chronic catarrh. The most effective remedy has been found to be sulphite (not sulphate) of soda, in

half ounce to one ounce doses, given twice a day for a few days, and then intermitted. If the horse is weak, some tonic, as a tea-spoonful of ground ginger, should be given with the soda. Inhalation of the vapor of carbolic acid has been found useful.

As to Virginia.—“G. W.,” Nepany, Ct. That part of Virginia around Richmond is perfectly healthy, pleasant, and fertile. Any Northern man settling there will undoubtedly be respectfully treated if he behaves himself as he ought to do in any place. If he mudds his business, and does not want to run for an office, he will have nothing to complain of there.

A Question of Morality.—“C. O. W.,” Medina Co., O. It is a perfectly honest business to train a mare—that as a farm mare is worth but \$150—and make her worth \$500 as a trotter. But if successful, it is not always a profitable business, for the reason that by working upon a farm steadily during the time needed to train and dispose of the mare, the extra money might often be earned twice over. Then again, one might fail and the time would be lost and the money besides.

Cooking Cotton-Seed.—“A. P. K.,” Greenville, Miss., writes us about cooking unhulled cotton-seed. He says: “I can prove by my experience that, so far as milk cows are concerned, cotton-seed, properly boiled while fresh, are as readily digested as the hulled seed, and may be used without any danger of injury from the presence of the hulls in the stomachs of the animals.”

Our Western Office.

The *Agriculturist* makes no claim to be especially Eastern or especially Western, but what its title indicates—wholly American. It has always been our aim to make a journal which should be welcome in every part of the country. Our office of publication is located at the great commercial center, New York, which is a matter of necessity for a paper of large circulation, as the facilities for producing such a journal are more abundant here than elsewhere. Finding a need of an office in the great commercial city of the West, we have opened one in Chicago, where our papers and books may be found, and any business in relation to the advertising, subscription, and other departments of the papers may be transacted. This office is in charge of Mr. W. H. Busbey, favorably known in connection with the *American Farm Journal*, Toledo, O., and other Western journals. Our friends who visit Chicago are invited to call at our office, Room No. 4, Lakeside Building, where they will be welcomed by Mr. Busbey.

Reports, Catalogues, and Journals.

THE MICHIGAN POMOLOGICAL SOCIETY, although scarcely three years old, is already well established and doing good work. Its report, published with commendable liberality by the state, is a handsome volume, and contains papers of interest and value.

THE OHIO STATE HORTICULTURAL SOCIETY, the butterfly of which the Ohio Pomological Society was the chrysalis, gives its report in a condensed form, containing, among other useful matter, an essay upon Small Fruits, by Lonis Ritz, of Plainville, Hamilton Co.

THE POPULAR SCIENCE MONTHLY (Appleton & Co.), keeps up the interest of its early numbers, and contains the best productions of modern scientific workers and thinkers. It is creditable to the country that such a journal finds support.

VICK'S FLORAL GUIDE.—We have before noticed the fact that Mr. James Vick, of Rochester, publishes his catalogue in the form of a quarterly, and he is early in the field with his first issue for 1874. Mr. Vick was formerly an editor, and can not get out of the harness altogether; so that in giving his catalogue proper, Mr. V. presents a number of horticultural items which are abundantly illustrated; and the whole is prefaced by a very handsome chromo of Double Portulacae.

MOON'S BEE WORLD is the title of a new apiarian journal issued by A. F. Moon & Co., Rome, Ga., the first number of which has just reached us. It is in magazine form of 32 pages. \$2 per annum.

WAITE, BURNELL, HUGGINS & Co., London, send us their wholesale seed list, which contains the usual standard varieties and some novelties. This is a very large seed house, and enjoys an excellent reputation.

SCIENCE GOSSIP.—We have for several years taken *Hardwicke's Science Gossip*, as being the best popular magazine devoted to scientific subjects in the language.

Though it is essentially English, we rarely get a number that has not much of interest to us, and we have often wished that a similar journal might be produced in this country. As the next best thing to an American popular monthly of this kind, we have a reprint of the English one by G. P. Putnam's Sons, who reissue *Science Gossip* at 20 cents a number. We do those of our readers who are in want of a popular journal upon natural science a service by calling their attention to this reprint.

Books Noticed.

For several months our notices of books have been crowded out, but we have made such arrangements as will, we trust, enable us to do better by publishers in future. While we can not agree to notice all works sent to us, we shall endeavor to keep our readers advised in regard to such publications as we consider useful.

SCHOOL AND COLLEGE TEXT BOOKS.—A valuable series of works of this class is issued by the well-known house of A. S. Barnes & Co., N. Y. Of those that have recently come to hand are *A Fourteen Weeks' Course in Chemistry*, by J. Dorman Steele, which seems to be an excellent elementary work upon the subject, and one in which we are glad to see the modern nomenclature employed. \$1.50. *A Manual of Moral Philosophy*, which accords no other commendation than that it is by Doctor A. P. Peabody, and was prepared for the use of his classes in Harvard. \$1.25.

LANDSCAPE ARCHITECTURE, by H. W. L. Cleveland, Chicago: Jansen, McClurg & Co. This neat little work discusses the principles of landscape gardening from a Western point of view, and is especially adapted to the wants of the rapidly growing towns of the Western states. It contains also an essay on tree planting upon the great plains.

HALF HOURS WITH THE MICROSCOPE, by Dr. E. Lankester. G. P. Putnam's Sons have reproduced in a neat style this popular English work upon the use of the microscope. It is mainly devoted to pointing out objects of various kinds that are of interest under the microscope, and to showing how to prepare them.

OUR COMMON INSECTS, by Dr. A. L. Packard, Jr. Salem: Naturalists' Agency. This is mainly a reproduction of articles that have appeared in the *American Naturalist*, and contains much that is interesting and valuable. Dr. Packard is one of our most competent and thorough entomologists, and we always, when we see a publication of his, regret that he is not more popular. In no branch of science is there so much need of popular works as in entomology, and we hope that some one will be found who is able to talk familiarly as well as learnedly about insects; but we have had no works since that of Harris in a style suited to the common people.

SEATS AND SADDLES, BITS AND BITTING, is the title of a work by Francis Dwyer, Major of Cavalry in the Austrian Army, published by Lippincott & Co., Phila. In this the whole subject of the mechanics of horseback riding is thoroughly and exhaustively discussed, and the work can not fail to be of great value to both civil and military equestrians.

A MAN OF HONOR, by Geo. Cary Eggleston. This appeared as a serial in *Heath and Home*, and is now published by Orange Judd Company. \$1.25. It is a pleasing story of Virginia life, without any attempt at the sensational.

SILVER AND GOLD.—Under this title J. B. Ford & Co. publish the report of Prof. R. W. Raymond, U. S. Commissioner of Mining Statistics, in a handsome form, illustrated, for \$3.50. It is a very full account of the various mines which yield what are called the “precious” metals, and describes the smelting and other metallurgical processes. Such a work, prepared by so eminently competent a hand, is highly important to all engaged in developing the mineral resources of the country.

WIDDIFIELD'S NEW COOK-BOOK, by Hannah Widdifield. Philadelphia: Peterson & Bros. \$1.75. We always notice a new cook-book with hesitation, as, like a dictionary, one can not judge of its merits or defects until after the intimate acquaintance that comes of use. At present we can only say of the one before us that it looks promising, and that such recipes as we have examined appear to be well considered and practical.

THE DAILY RECORD; OR, EVERYBODY'S DIARY FOR 1874. Hastings & Co., 202 Broadway. \$1.50. This is a diary of the size of a large foolscap page, which gives sufficient space under each date for such record as it is desirable to make. It would be found very convenient for a farm journal. A series of tables of various kinds and an almanac occupy the first part of the book, and a thin blotter is placed between the leaves—a capital plan to insure neatness.

How to Make a Harrow.—"W. B. S.," New Britain, Ct. To make a square harrow in two parts hinged together in the center, take four pieces of 4 x 4 oak or maple scantling six feet long, and eight pieces three feet long. Mortise the shorter pieces into the longer ones twenty inches apart and six inches from each end, thus making two frames or gates six feet long, three feet wide, and with four cross-bars each. Hinge the two gates together by means of three pairs of eye-bolts with a long rod passing through each pair. Put five teeth 12 inches long and 3/4 inch thick of square iron rod into each cross bar, and three teeth into each main bar between the cross bars. There will then be 52 teeth. This harrow should be drawn from one corner.

How to Burn Oyster-Shells.—"J. L. D.," Columbia Co., Pa. Oyster-shells may be burned in a pit similar to that in which charcoal is burned. The shells should be piled in a heap with layers of wood chips, brushwood, and small cordwood intermingled. A layer of dry wood split fine should be placed at the bottom of the heap, arranged so that a draft is made to the center of the heap, in which are a few sticks of wood placed on end to form a chimney. The heap should be covered with sods or coarse litter and then with earth, leaving a few holes for air until it is well kindled. Then the holes should be closed up almost entirely.

Plants Named.—"H. N. P.," Illinois. We can not undertake to determine plants sent without flowers. You do not say whether it is a native or not. If persons sending us plants will only take a little pains to send specimens in flower together with the leaves we will name them. . . . "A. N. G.," Madison, Kan. Your plant is *Callirrho pedata*. It has no common name. It does well in cultivation, and is often found in gardens at the East.

Too Heavy Aftermath.—"H. J. B. C.," New Bern, N. C. It is not economy to permit too heavy a growth of grass or clover to remain upon the land in the fall. An aftermath that will interfere with the early mowing of the grass in the spring is excessive. To prevent it we would pasture the meadow somewhat to reduce the quantity, or mow it a second time, and expend the value of the hay so made in fertilizers for top-dressing. In the present case it is probable that a good raking with a steel-tooth hay-rake, in the spring, would gather a large quantity of the rubbish, which might be used in the stables as litter and returned to the meadows at some future time.

The Northern Limit of the Dandelion.—The northernmost limit at which any flowering plant has been found is lat. 82° N. Dr. Bessel, of the Polar expedition, found at that high latitude a form of the common Dandelion, a Mouse-ear Chickweed (*Cerastium alpina*), *Draba alpina*, and a grass (*Poa flexuosa*).

Hard Crop and Vertigo in Poultry.—"A Subscriber," Adams Co., Ohio. The cause of hard crop in chickens is indigestion, which is also the cause of vertigo or dizziness. We would suggest a change in the feed, a reduction in the amount, and a stimulant in the shape of two pills of equal quantities of ground cayenne pepper, ginger, and copperas, as large as a pea, given daily for a few days. Poultry need a frequent change of food to keep them in health, and a supply of coarse gravel is also absolutely necessary for them.

Pollen in the Atmosphere.—An English physician, Dr. Blackly, has satisfied himself that that annoying disease the "Hay Fever" is caused by the pollen of grasses. He experimented upon the amount present in the air by exposing at different heights plates of glass covered with some adhesive liquid. At 4 ft. 9 in. from the ground the highest number of pollen grains obtained in twenty-four hours was 880 on a square centimeter (about two-fifths of an inch). By means of a kite he experimented upon the quantity present at higher levels, and found that at a height of 1,000 feet there were many times more than the average found near the earth, besides great numbers of the spores of grain fungus or smut were obtained.

Percheron and Norman Horses.—M. Simons, of Orne (France), connected with the Department of Agriculture and Commerce in that country, in a letter written to Mr. J. J. Parker, of West Chester, Pa., states that the true Percheron horse is now very scarce; that those who raise horses for sale as Percherons in the neighborhood of Chartres—the center of the Percheron horse trade—purchase foals in Belgium, Flanders, and other places, and after feeding them until old enough sell them as Percherons. It has now come to pass that all

heavy gray horses are classed as Percherons. But these are far from being the true race. This is but an enlarged Arab, with all the good qualities, the soundness, and endurance of the original race from which he springs. His color is a gray white or a silver gray. He must be kept under nearly the same condition of climate as in the Perche to do well. Being gentle, he must have gentle treatment. He must be well fed. His rations are 17 lbs. of straw, 22 lbs. of hay, and 20 quarts of oats.—Those remarks, which we know to be well founded, are worthy of notice by those who are purchasing heavy, coarse-boned, large-footed, lymphatic, and necessarily unsound dark gray horses, which are called Normans or Percherons, at high prices, with the certainty of future disappointment. Not long ago, we saw an importation of several so-called Percherons, of which only two could justly claim the title, and the difference between the true and false Percherons was abundantly clear. For the improvement of our native races we must have animals of pure breeds, or we make a failure.

Sheep vs. Goats.—"J. W.," Lynchburg, Va. We would not advise you to change your sheep for goats. Sheep's wool is a staple article of ready sale, while goat's hair is not. Goats are equally liable to be destroyed by dogs as sheep are. The best plan is to put the sheep every night into a pen, with a high board fence around it, and during the day keep a gun loaded with buckshot handy. A dog upon your premises without the owner is a trespasser, and if engaged in hunting sheep should be shot upon sight.

Muck on Sandy Soils.—"W. A. S.," Sunbury, Ct. A dressing of one or two hundred loads of swamp muck per acre upon sandy lands with the addition of twenty or thirty bushels of lime per acre, would be of great benefit. We have found no immediate good effects from the application of raw muck to such soil, but when we have filled the barn-yard with it to a foot in depth in the fall, and allowed the cattle and hogs to run over it and work it up along with the drainings from the stables, we have found it excellent for grass and clover when spread early in spring. The best plan now would be to haul it out and spread it in the barn-yard as soon as it is dry.

Cotton-seed and Flax-seed Meals.—"E. K. H. T.," Indianapolis.—Cotton-seed meal from hulled seed at \$25 per ton is a cheaper feed for milk cows than flax-seed meal at \$30 per ton. There is a greater production of cream from the cotton-seed, and the butter has a better color. Caution should be exercised in feeding either of these meals, lest too much be given; four pounds a day will be sufficient with other feed. Crushed oats is better to feed with them than corn-meal. For fattening stock six pounds a day of either may be fed.

Orchard Planting and Vinegar.—"J. J. H." As you do not state whether you live in Canada or Florida we can not advise you about an orchard. Vinegar can be made in less than one year from cider by keeping the room always at the temperature of 70 deg.; or by the use of an apparatus made in Ohio, and advertised some time ago in our columns, it can be made in a few days without the use of "drugs."

Poultry Houses.—"W. B. C.," Westchester Co., N. Y. There is frequently very unnecessary outlay in building poultry houses. A cheaply constructed house may be as warm and as convenient as the most expensive one. The plans given in the *Agriculturist* are adapted to both styles of building, and those who do not desire a costly one may construct a cheap house upon the same plan by varying the style and material. It is unnecessary to follow the plan exactly in any case.

Sulky Plows.—"C. D. B.," North Hatfield. We can not give you the address of a manufacturer of sulky plows; but there are several in Chicago, St. Louis, and other Western cities, and almost any dealer in plows can procure them.

Irrigation by Flooding.—"R. A. F.," Franklin Co., Mass. Mere covering a grass field with water in the spring of the year does not necessarily add to the fertility of the field unless the water brings with it some fertilizing matter in suspension or in solution. It is the suspended matter brought down by rivers which makes the annual spring floods so productive of grass upon the meadows of river bottoms; but the mere flowing of spring water upon grass would be nothing more than a watering, and not fertilizing, in the sense of manuring.

Bronze Turkeys.—Mrs. "B. J. C.," Mankato, Minn. Bronze turkeys are a variety supposed to be descended from the wild turkey crossed upon the

domesticated bird. They take their name from a peculiar brilliant bronze reflection from their plumage, and grow to a large size, birds of 36 to 40 lbs. being not uncommon. Mr. Wm. Clift, of Mystic Bridge, Ct., is an expert in regard to these birds, and we believe can supply them or the eggs.

Bone Mill.—"Englishman," Lynchburg, Va. The best bone mill is the Bogardus Mill, which costs \$500. It requires at least four horse power to run effectively. Crushed bone can be purchased in this city for \$35 per ton.

Grass for Pasture.—"T. G.," Kittrells, N. C. The best grasses for a pasture are timothy, orchard grass, blue grass, red top, with red and white clover. Which grass to choose depends much upon the soil. Upon rich limestone lands timothy, orchard grass, blue grass, and red clover may be sown; the quantity of seed would be six quarts of timothy, one bushel each of orchard grass and blue grass, and six quarts of clover. The blue grass, if it succeeds, will not show much until the others begin to run out, which will be in three years. Upon moist soils red top and timothy should be chosen. Twelve quarts of timothy and one bushel of red top would be proper quantities.

How to Feed Rye.—"W. S. L.," Ansonville, N. C. We have fed rye to horses and cows as green fodder, cut when just coming into ear, in which state it is very excellent feed. To feed rye that has been cut ripe, we would thrash it, grind the grain along with corn or oats, cut the straw in a fodder-cutter, moisten it with water, sprinkle a handful of salt and three quarts of the ground feed upon a large pailful of the moist cut straw. This makes a very good feed for an ordinary sized horse when working moderately.

To Preserve Eggs.—"K. H. S.," says that he has kept eggs for a whole year as good as fresh by packing them in plaster.

English Cheese.—G. C. Hawk, Cleveland, Tenn. The best English cheese is the Stilton, and next to that is the Cheddar. The Stilton is a very rich cheese, and has a portion of cream mixed with the milk before the curd is made. It sells in this country for about 60 cents a pound. The Cheddar sells for 40 cents a pound. It would seem as though we should be able to make such cheeses here, having a great variety of pasture and other circumstances favorable for it; but the skill is wanting. In the *Agriculturist* of April, 1867, there is an article describing the manufacture of Cheddar cheese (with illustrations), in a dairy in Otsego Co., N. Y., by which it will be seen that the manufacture of fancy cheese is already introduced in that locality; but we have not heard of its introduction elsewhere. The price of such cheese should be a great inducement for experiment.

Salt Muck for Grass.—"F. G.," May's Landing, N. J. Salt meadow muck alone is not sufficient to produce grass upon uplands. It is a very fair basis on which to build up a good fertilizer, but it lacks lime and nitrogen. These may be supplied either by the admixture of burnt shells or stone lime and ammoniacal substances, of which dried blood or flesh in powder is probably the best and cheapest. We would suggest a compost of lime and muck in proportion of five bushels of lime to one cord of muck, of which 20 loads per acre should be spread in the spring, followed by 250 lbs. of the dried blood or Peruvian guano.

The Patrons of Husbandry.

HOW THE "GRANGERS" APPEAR TO ONE WHO LIVES AMONG THEM.

[The remarkable increase of the Order of Patrons of Husbandry has been before alluded to, and we find the number of Granges swelling rapidly. Within a short time State Granges have been organized in New York and Massachusetts States, in which the order had heretofore made comparatively slow progress, while the forming of Subordinate Granges is a matter of daily occurrence. We are indebted to one of the chief officers of the order for information in regard to its progress. The last Bulletin received (late in November) gives the number of Subordinate Granges up to that date at 8,262, with a reported membership of 619,650. During the month of October last 1,050 were organized, a number in marked contrast with that for the same month of the preceding year, when only 91 were reported. The following article is by a resident of that portion of Illinois where Granges are numerous, and may be regarded as an impartial view of one not identified with the order.—Ed.]

It is assumed by some that the Patrons of Husbandry are necessarily violent partisans. Can any one imagine the abruptly courteous and hospitable farmer of the West as a violent partisan, determined on a narrow-minded course toward any particular class? The man who believes so thoroughly in his Western soil, and who is always glorying over his big corn and the rapid development of the country, can not be, in the nature of things, such a man as he is often painted by writers who associate so many unheard of things with the name "Granger."

The farmers of the West are, as they have been, open-hearted, generous; in the main contented. They nursed a special interest beyond its natural growth, and were surprised to see this interest turn against them. Indignation followed naturally, and discussion caused them to look about for a remedy. They found interests combined against them, and they found it necessary to combine in their own interest. But before this combination that made them a power had taken place, the order known as Patrons of Husbandry was at work in its own special field. It now became the basis of combination, and afforded no very great opportunities for display of ill-nature. It appealed to the farmer with a touch of idealism in his nature rather than to the prosy, discontented croaker. It became strong with the intelligent and progressive rather than with the stubborn, old foggy, and non-reading classes. In short, the organization made a direct appeal to all the better classes of farmers not conscientiously opposed to secret societies, and formed into an active body the good elements in rural society.

The sentiment of the order is generous, and there is nothing to suggest the harboring of a policy that could grow into a violent one. Although it has been dragged into the discussion of puzzling questions, its general attitude has been consistent, and it has encouraged the growth of a healthy sentiment among farmers. Under the cover of the organization, new combinations of extraordinary strength have been formed. These are not the consequences of the working of a resentful spirit, but are the first organized attempts to remedy a great evil; the first general evidence of a common business shrewdness on the part of Western farmers.

A desire to meet a wrong face to face and make it right, and the ability to protect self, do not make violent partisans. The truth is, the Western farmers are just as generous as Grangers as they are as neighbors or entertainers of new-comers, and they are no readier to become the blind instruments of designing men than before.

It has pleased some people to make something of a bugbear of the Grange movement, and persons really in sympathy with it as a matter of principle, have turned away and hesitated to investigate. That the present status is promising, all must admit. That there must be a strong inward growth in the future to make the order satisfying, its warmest friends do not deny. In many cases there is a shallowness in the forms that annoys the thoughtful. In other cases there is too much of what we denominate a "gushing element," to satisfy the earnest business man. There is possibly too much machinery of the simply ornamental kind to wear well. But none of these are serious objections. If the order is to have a future it will have a better future in this respect, and will depart from whatever experience has demonstrated of questionable utility. The growth of the order was not as rapid from the first as many people imagine. The rapid growth did not commence until the organization had been on trial some years. The necessity for thorough organization brought its machinery into use, and the order at once became popular as no other order had ever been among farmers.

Seen from a distance the ground occupied by the Grangers suggests contention, aggressive lines, and general confusion. Seen from the place of operations there is nothing of this. We see simply farmers striving after a better social life, like other men; seeking a higher standard of education and seeking to make their business as profitable as possible. All these objects are commendable, and when we consider their attitude on the railroad question, we must take the order as an order, not select certain irate and thoughtless men as representatives. Farmers stand committed to war against monopolies, and they have conducted an aggressive campaign on their own plan. The great majority of farmers realize the advantage of railroads, and have familiarized themselves with expenses and with difficulties in the way of successful management. They made demands that were treated with contempt. Railroad companies resented the making of any demand as an impertinence, and this policy precipitated a struggle which can not end to their advantage. It is often declared that the farmers have been hasty, resentful, and short-sighted. But in this respect their conduct will stand comparison with that of corporations directed by wise heads and financiers who have indulged in no small amount of railroad policy. In the present conflict with the farmers will the present policy of the railroads win? We answer no. Because

their interest is, in this case, identical with that of the farmers. Many of the roads want farmers on their lands, want producers along their lines, want the country developed by a policy that encourages rather than discourages farming. Any one act discouraging or persecuting farmers, reacts to their disadvantage, and it will be simply to the interest of great Western lines to do in common what many individual roads must do—make reasonable concessions to men who have a lasting interest in the success of our railroad system. The sooner this is done the better, and then will it be discovered that the Grangers are not wanton assaulters of any interest, but that they are quiet, good-natured people, seeking to make life pleasant by ordinary and legitimate means.

X. Y. Z.

Bee Notes.—Advice to Beginners.

BY M. QUINBY.

If bees were put into winter quarters in good condition but little can be done for them at this time. Yet there is often something gained by thinking. Suppose on looking over the bees something is discovered going wrong. First be sure it is wrong, and then consider the remedy. Will any remedy with which we are acquainted apply in the present case? An important duty in this world is to think of consequences. As I do not expect that any readers of the *Agriculturist* have left their bees on their summer stands for the winter, it will be unnecessary to detail management with reference to that. Winter has commenced this season in time to make out a long one. If its severity is in proportion to its length we must expect the effect on our bees to be serious, unless extra pains are taken. Heed what was said last month.

I am in favor of urging another class in our community to engage in bee-keeping. I mean the ladies. It has been recently demonstrated that they have the ability to do many things heretofore thought inexpedient, if even it were possible. Many have the strength, and many that have not have the skill to direct in their management, as is abundantly proved. Some of them lack the courage to begin and patience to learn how, and boldness to brave the sting. Most minds require considerable discipline to surmount these obstacles. For a fine lady to receive a sting is to be dreaded, yet the smart is no more in a fair face than in a farmer's flesh. Let us endeavor to learn all we can of the subject, and how stings may be avoided, as well as how they interfere with the business.

BEE STINGS.

The fear of stings is one of the greatest obstacles in the way of successful bee-keeping. I have had patent hive men visit me to exhibit their hive. I am apt to make up my mind as to the value of his hive by going with the man among the bees. If he wants protection for his hands as well as face, or boasts that bees never sting him and then dodges on hearing a bee flying near, or if one approaches, seemingly disposed to make his acquaintance, he makes a strike with his flat hand or whisp of grass to drive it away, or if his quick motion attracts still others, and he leaves defeated whether stung or otherwise, I am apt to think that a hive of his constructing lacks some essential points, because he has not yet become acquainted with bees well enough to know what is wanted in a hive. If he has some valuable contrivance it is often purloined from some one else; and it is generally the case when looking at his hive that the only thing new about it is an idea taken from some good hive so changed as to make it worse. But when a man accompanies me into the yard and manifests no fear of stings, and is willing or even anxious to go right into the hive, I predict that he is a successful bee-keeper, or will become one if he gives his attention to it. Mr. Langstroth on his first visit to me showed more boldness among bees and avoided stings better than any man I ever met. And where is the man better acquainted with them than he is. The fear of a sting never deterred him from any point he wished to investigate.

There are many ways to avoid the greater number of stings, as is abundantly proved. But first we must try and understand under what circumstances bees are not disposed to sting; also when they are disposed to do it. This learned, we have taken one step—an important one—towards successful bee-keeping. We all know that bees will not leave the hive on a cold frosty morning when undisturbed and make an attack. Again, it is known by many that a bee away from home never stings unless first made fast. When in the fields, gathering from the clover blossom, getting drink from water spilled near the well or spring, sipping from ditch or drains, they always pay strict attention to their own business and never sting if not caught fast. How few understand this. The training of nine-tenths of the community has been such as to make them think that a bee is angry and disposed to sting at all times and on all occasions when

ever there is an object at-hand. Having witnessed them quietly at work gathering stores from a thousand fields, sipping water from a thousand rills, or sipping juices from the punctured grape or apple, or getting sweets from the sugar barrel in grocery or pantry without molesting any one does not remove the association of bees and stings. These persons suffer more in imagination than they do from the real thing itself. Generally more complaint is made by those that have never been attacked than by those who are stung most. One attack that proves serious is reported a thousand times, while others are not mentioned. The child can be taught to fear the imaginary hobgoblin as soon as it is dark. The timid are taught on the same principle regarding bees.

I shall not pretend that bees do not or will not sting on sufficient provocation. Means of defence were given them no doubt for a wise purpose. It has been so arranged by the Creator that stores gathered for their own use should be shared by man. Man, taking this for granted, in ignorance of their real nature, has attempted to obtain it by brute force alone, regardless of the effect on their disposition, and for centuries succeeded only by taking life at the same time. We are now enabled to divide the results of their labor without opposition, and justice is a little nearer done. We have ascertained that a sudden jar awakens vigilance. They seem to understand that it would dislodge their combs and ruin their home if continued. Anger is aroused, and if the colony is strong and well supplied many of them come to the outside to see what is the matter. A quick motion made by pounding or striking is at once perceived, and it induces an attack. How their ideas are communicated is somewhat conjectural. When we examine the sting we find but a tiny instrument to inflict pain—a bee could not wield a powerful one; but to make its effect powerful the Creator has added a subtle poison, secreted in a little receptacle at its base, and when used, if it only penetrates the cuticle, some barbs at the point hold it there more firmly than any muscles hold it to the bee. It is usually left in the flesh until sufficient venom is transmitted to cause acute pain. If not left there is scarcely any pain felt. The poison that is set afloat in the air awakens the attention of the whole apiary. Any moving object, especially one with a quick motion, is attacked. Every sting inflicted sets afloat more of the poison, and the disturbance becomes more general. This seems to be the kind of language understood by the bee. The exclamations of some persons when among them seem so near like that given out by the poison that they do not appear to perceive the difference, and act accordingly. Now, without endeavoring to show further that this is language, we act as if it were, and set about "confounding" it. Smoke will do it effectually. Most substances while being consumed by fire will furnish the material. Smoke made of tobacco was once thought by a few to do it best; but subsequent experience shows other things better and cheaper. Linen or cotton rags, sawdust, paper rolled up so that it will burn without blazing, rotten or decayed wood made very dry is probably the least trouble. Wood that is solid or hard when green is better than the softer kinds. I do not discover much difference in the variety; hickory, maple, or apple-tree are good. Let it be decayed so that it will just hold its shape when sawed or split into sticks an inch or more square. An improved method of applying this smoke will be given at some future time. Set one end on fire, and if dry it will burn without a blaze. A few pieces will smoke for hours. If the bees are disturbed, and their poison sent out in the air, this smoke mingled with it neutralizes or changes its effects. The smoke of tobacco subdues even better for the time being, but something remains unpleasant to them—makes them cross; while the milder smoke seems to soothe as well as disarm, and the disturbance is not remembered.

Bees collect a substance called bee-glue or propolis, with which they seal up all crevices. Any opening or hole not large enough for a bee to pass is filled with it. Boxes are sealed fast, frames glued together, hives held to the bottom board, and top to movable comb hives fastened by it. In a warm atmosphere it is soft, tenacious; in a cool one hard and brittle. Now anything fastened by this substance can not be moved in a cool morning without a jar. The more there is of it the greater the snap, and bees unaccustomed to such disturbance rush out of the cluster or entrance and immediately there is poison in the air. Now, if we have the smoking wood at hand, and the smoke is blown directly upon them they at once return. Others may take their places, and if they too are disposed to resist they will throw up the abdomen so that it will not touch the next one, and press out around the sting a tiny drop of clear liquid poison so that it may be seen. All that appear and show this should have a portion of the smoke, which may be used at intervals as they appear. If all unnecessary jarring is avoided they are soon quieted. In summer, in the middle of the day when the sun shines, this propolis is pliable, and most of the manipulations can be per-

formed without a jar. If it is a movable-comb hive you can take off the boxes, take out frames, look for the queen, and be very likely not to alarm a bee. Have the smoke at hand, so that if they do accidentally get an alarm they may be at once quieted. Another thing: If it is in a season of honey, and the bees are engaged bringing it in—especially Italians—they are not often disposed to resent what at another time, a few hours earlier, might be thought a gross insult. When bees are filled with honey or syrup they are not disposed to make an attack. If you wish to train bees to make them good-natured always when practical work with them in the middle of a warm day. Work slowly; a quick motion may attract unpleasant attention. Avoid crushing a single bee. A little time gained now by quick motions may be lost in removing stings another day. If no poison has been set afloat they have nothing to anger them. It is possible, if no anger is called up, that having no use for their poison little or none may be secreted. After a few generations, at any rate, we shall have little fear to go among them and get acquainted. And when we get a few more interested seekers after their real nature we shall progress in the same ratio in pleasurable and satisfactory bee-keeping. Let us resolve to give no cause of resentment.

Ogden Farm Papers.—No. 47.

Good farming is good farming all the world over. This must be the result of the reflections of any considerate person who compares the agriculture of other countries with that of his own. The one universal purpose of the farmer is to devote the fertility of his soil and his facilities for its management to the production of such returns as will pay the largest profit in the comforts of life, in the increased value of his property, or in actual money. In seeking the accomplishment of this purpose he depends upon fundamental principles, and works in obedience to fundamental laws, which are everywhere the same. Soil and sunshine, air and water, and the never-ending combinations and changes by which they aid or retard the growth of plants—these are invariable from one end of the world to the other. Processes vary with circumstances and conditions, but the principles on which they depend are everywhere the same, and the best farming of Europe differs from the best farming of America only in details, not in general principles.

A careful observation of the agriculture of the best cultivated parts of Europe confirms the opinion formed at home that the only good farming anywhere is the very best farming that under the circumstances is possible; and that, whenever possible, *the highest kind of high farming pays the best*. It is not to be understood by this that the finest buildings, the most elaborate implements, the most costly animals, the most lavish outlay for artificial manures, are the index of good management—they are often the opposite—but that the fullest measure of success will attend the efforts of that man who, in small things as in great ones, makes the most of his circumstances, and whose ambition never stops short of the highest excellence that is within his possible reach; who is never satisfied with what he has done but is always striving to do more.

There are more of this class in Europe than in America, and herein lies its chief advantage as a school for the agricultural student. Most of the problems which interest us and form the subjects of our discussions may be better investigated there than here. In view of this I applied myself during my recent trip to the obtaining of light on the much vexed question of deep plowing, one which has always had a prominent place with our writers, and about which no definite early conclusion seems probable. It has certainly not been less

talked about and written about and quarreled about in England. When agricultural writing first commenced there it at once took a prominent position, and the columns of the British agricultural journals are to this day more taken up with it than with any other topic on which opinions differ widely. Arguments on both sides are plenty—on either side, viewed by themselves, they seem convincing—and it is at least difficult to decide which has the best of the discussion. In practice, the deep plowers find comparatively few adherents, for there as well as here it is the almost universal custom to plow only to the depth of about six inches. Personally, I have always sided with the deeper faction, and I am not now disposed entirely to abandon their position. At the same time, the more I investigate the matter the less am I inclined to urge the adoption of their recommendations. There is much force in the statement of a recent English writer that if by deep plowing you convert the upturned subsoil (by the aid of manure) into a surface soil, you by covering up the surface soil convert it into a subsoil, and place its greater fertility beyond the reach of the developing action of the atmosphere and thus lose its effect. On the other hand, there is no getting around the fact that gardeners and nurserymen have great faith in the efficiency of "trenching," a process whereby the surface soil is completely buried beneath the upturned subsoil. In their cases, however, the quantity of manure used is much greater than is possible in the larger operations of the farm.

In this matter it would certainly be safer to advise that all attempts at deep plowing be very carefully made. Many instances can be cited where it has been decidedly injurious. Ogden Farm offers one of a serious character, where nearly ten acres of land was so far injured by turning up a few inches of poor cold clay that five years' time and an expenditure of manure and labor to the value of more than the original cost of the land have been insufficient to make good the damage. Perhaps corresponding cases of benefit may be adduced, though I know of none that appeals so strongly to my judgment.

After considering the question on all sides, what should be our practical recommendation? It seems especially clear to me after a careful examination of the farming of some of the best parts of Europe. It is certainly true that, taken as a whole, the best European agriculture, like the best American agriculture, does not depend on deep plowing. The men who succeed the best, there as well as here, are generally shallow plowers rather than deep plowers. Many of them no doubt believe, theoretically, that deeper plowing would be better; but whatever their theory may be, their practice is to confine the turning of the soil to the first five or six inches, and to keep their manure near the surface. The only thing of general value that has been proved about the question after all these years of argument is that it has two sides to it, and I do not hesitate to recommend my readers to be very cautious how they enter into the discussion with their own plowshares. Study, investigate, and theorize as much as you like, but be very slow to abandon a custom that is known to be successful for one that is of uncertain promise. I do not myself desert the deep plowing party, but, on the other hand, I do not recommend its teachings for general and immediate adoption. In many cases it will do good,

but first trials should in all cases be made on a very limited scale, for on many soils it does great harm. There are channels enough open for the introduction of improved processes which will pay without question, and the laudable energy of enthusiastic men need never lack for an object. It is the safest plan to stick to the best customs of the best farmers until they fail to satisfy, and then to amend or alter them only as careful experiments shall prove the change to be a good one. The truth is that we know by far too little of the how and the why of vegetable growth to decide on the value of any improvement in advance of its actual trial. The way in which agricultural writers have been forced to abandon their recommendation for the immediate plowing under of stable manure, and to content themselves with finding out the reason why the opposite custom of farmers (to spread manure on the surface and leave it there) was better, is too fresh in mind for any prudent man to insist that deep plowing is to be or ought to be the universal panacea of agriculture, while he can count on his fingers the really successful farmers who have adopted it, or, who having once adopted it, have found it worth their while to keep it up. Of course, the expense of deep plowing has had much influence in retarding its spread, but the expense is of itself no argument against it, and it has not been taken up where (as on the larger farms of England) mere expense is no argument against any process that is sure to pay.

It was thought that the use of steam in plowing would finally decide the matter in England, and that with the increased motive power thus placed at the disposal of the farmer there would be a general deepening of the furrow. The result has been quite an opposite one—a general giving up of the furrow. Only where there is clover or grass to be turned under is the plow used at all in steam cultivation. In all stubble and fallow work (which is much more in proportion to the grass work than it is here) there is substituted for it a deep-tined grubber or cultivator which tears up and loosens the ground very thoroughly without reversing it at all. The cultivation is deep, it is true, but the top soil is kept at the top, and the subsoil is only torn asunder and loosened where it lies. This secures the great advantages of deep plowing—better drainage and better protection against drouth—without entailing the disadvantage of burying the richer surface soil away from the action of sun and air and out of the reach of surface roots. It is, in fact, more like our long advocated but too costly subsoiling, and it constitutes the most effective cultivation yet known.

As a whole, the farming of England is the best in the world. The farms are usually large, and the farmers men of intelligence and of large capital. More attention is paid there than anywhere else to the making of manure; grain is largely grown; and the system of a regular rotation of crops, to maintain the fertility of the soil, is almost universal. Over a large part of the country the cash profit of farming is secured by the sale of grain, but the fertility of the land, the ability to produce grain, is kept up by the feeding of a heavy stock of cattle or sheep, which are kept mainly for the sake of the manure they make, and which are largely fed on purchased food—in great part oil-cake and Indian corn imported

from America. Such a complete system could hardly be carried out on so large a scale on many farms in this country, for few of our farmers have the necessary capital; but it is, after all, the system toward which we should work and to which we must look for the permanent future of our agriculture. Our farming can never be perfect, nor anything like it, until we shall have reached the point of a constant improvement of the soil. A constant deterioration has been a necessary consequence of the rapid spread of population over the whole breadth of the land, but it must before long be followed by a wave of better farming, which alone can enable such a population to be self-supporting. Happily the improvement already made on farms at the East which were considered to have been exhausted, shows that the injury was not deep, and that the pioneers who have been tempted westward by a virgin soil have left behind them a fair field for the establishment of the better agriculture that an older and denser community demands and makes possible.

Surely no one could be better placed than the Eastern farmer for the extensive adoption of the system of feeding as a means for enriching the soil. He has a home demand for meat which is not likely to fail, and there is apparently no limit to the quantity that Europe can take from us. In England especially the price of all manner of food is very high, and is growing higher every year. Animal food has never been used by the laboring classes to anything like the extent to which it is with us, and the advancing price marks a constantly increasing scarcity. If we can ship our corn from Illinois to England and sell it there at a price that leaves a profit to the English feeder, we should surely do better to feed it ourselves and save the freight on the very large proportion of it which is lost in the processes of digestion. As some one has cleverly expressed it: If we can't pay freight on 20 bushels of corn from the Mississippi to Liverpool, let us pack them in a pork barrel and try it that way. Thus shall we not only save three-fourths of the freight, and clear a much better price for our crop, but we shall save to our farms the whole manurial residuum of the grain with which to grow larger crops in future.

In theory nothing could be better than such a solution of the serious difficulties under which Western farmers are now struggling. How it would work in practice (on a large scale) it is not so easy to say. There are difficulties in the matter which can hardly be computed, but if by any process it ever becomes possible to dispense with the speculators and middle-men who block the road between the Mississippi and Liverpool, so that the producer shall have no unjust tax to pay in the transfer of his products and the collection of his pay, there can be no doubt of the result. At the same time, in instituting this reform, the farmer must be careful not to reform himself out of existence. The speculator and middle-man are there because they are needed. They are not just the model that a millenarian would set up, but, such as they are, they have grown up in response to a living demand, and they are the only existing medium for the transmission of produce and money between the farmer and his final customers. Sweep them off from the face of the earth to-day and to-morrow your occupation is gone. The dairyman of the West can not peddle his own cheese in the streets of London, but London is one of his

great markets, and until he can find some better way to reach it he will gain nothing by grumbling about the present way.

Will he gain by grumbling in any case? So long as he must use the bridge, why waste breath in abusing it? If there is anything in the signs of the times, we can see a fair gleam of daybreak for the farmer in the quarter whence other classes are getting relief. It is too untried as yet for us to say how much it will really amount to, but thus far there appears no valid reason why coöperation may not be of almost unlimited value to the agricultural interest. What is needed in the transmission of produce is capital and commercial skill. By association, farmers ought to be able to secure these. At all events, the experiment may be made without very serious individual risks, and it is worth trying. Its success will depend very much on mutual confidence (a plant of slow growth in agricultural districts) and on the chance of getting agents who will work as efficiently for a moderate fixed compensation as they would under the stimulus of individual speculation. Coöperation will be sure to work well in times of high prices and great prosperity; its sore trial will come when trade is dull and when money must be lost, and the association will always have to compete with the established traders, who have a large capital at command, and who are accustomed to take heavy risks. It is no easy matter to reform the world's way of transacting its business, but by a well-sustained effort it may doubtless be done, and if the best farmers of a fertile county will make the effort, agreeing to stand by each other through thick and thin, they will have a sufficient promise of success to fully justify the attempt.

Orange Judd.

Among the many requests made by the readers of the *Agriculturist* probably none has been so frequently presented as that asking us to publish a portrait of Mr. Judd. For reasons which were no doubt satisfactory to himself, Mr. Judd has never acceded to this often repeated demand. As he is now temporarily absent, and so far away that he can know nothing of the matter, his associates have concluded to risk the displeasure of a single individual in order to gratify many thousands by the publication of the often called for portrait, which will be found upon our first page.

Thinking that a biography should not be written until the subject of it has closed his career, we shall here give only a brief sketch to include such points as may have interest to the readers of the *Agriculturist*.

Orange Judd is the son of Ozias Judd, one of the pioneer farmers of Niagara Co., N. Y., and afterwards one of the first settlers of Kansas, where he lost his life in one of the conflicts that attended the early history of that State; he was born in 1822, not far from Niagara Falls, and passed his youth and early manhood in the hard labors of what was then a farm in the "far West." Having a strong taste for the natural sciences, and his desire for an education being very strong, he almost solely through his own exertions entered and sustained himself at the Wesleyan College at Middletown, Conn., from which institution he was graduated in 1847. After completing his college course Mr. Judd entered the Chemical Laboratory of Yale College, where he devoted three years to the study

of analytical and agricultural chemistry. A few years were passed in teaching chemistry and other branches of science, and in lecturing upon agriculture, after which he, in 1853, became editor of the *American Agriculturist*, founded some years before by Messrs. R. L. & A. B. Allen. At that time agricultural journalism was, if not in its infancy, at least in a very feeble state, and editors who had a proper foundation in a scientific education were indeed rare. In entering upon his editorial career Mr. Judd not only brought great industry and untiring energy, but a thorough preparation for the work. His influence soon made itself felt in the paper, and in 1856 he became its sole proprietor. When the *Agriculturist* first came into Mr. Judd's hands one person could attend to all the subscription and advertising business, and also write the wrappers and fold and mail all the papers, a task that now requires some thirty persons for its performance. Mr. Judd brought besides editorial ability to the paper a remarkable business tact and energy. He determined in the first place to make a paper that people would want, and in the second place to let people know of it, and it is to a strict adherence to these two points that his success has been due. He from the first determined that the advertising pages should be as carefully edited as any part of the paper, and, though at great immediate pecuniary loss, excluded quackery of all kinds and all advertisements of a doubtful character. The subsequent increase of the business of the paper, to which the publication of agricultural books had been added, led to his uniting with Lucius A. Chase and Samuel Burnham, Jr., in the firm of Orange Judd & Co., and the firm has been since enlarged by the accession of C. C. North and A. P. Miller. During the early portion of his editorship of the *Agriculturist*, Mr. Judd was for several years also the agricultural editor of the New York Times. In 1862 he went to Europe, but soon returned on account of the disturbed state of the country at home. During the war he was actively engaged with the Christian and Sanitary Commissions in affording relief to the soldiers in the field, an occupation in which his health was no doubt permanently injured. In 1867 he visited Europe again, and made an extended tour. Being warmly interested in the university at which he was educated, and feeling that its facilities for teaching the branches in which he was especially interested were inadequate, he erected at his own expense a large and magnificent building for lecture rooms, museums, etc. This building, probably the most complete of its kind in the country, is now called the Orange Judd Hall of Natural Sciences. We have already alluded to Mr. Judd's great industry; he always seemed to forget that there was a limit to human powers, and until within a few years never thought it necessary to spare himself mental or bodily labor. Unwillingly yielding to the advice of others, he passed a portion of the winter of last year in recreation in Florida, and this winter he passes quietly in some part of Europe, where it is hoped he will find the rest he has so well earned. As to our portrait, we are sure that it will surprise many, as Mr. Judd has held the attention of the agricultural public for so long that those who do not know him suppose him to be gray and venerable. Being of a nervous temperament and having a very mobile countenance, he when animated by conversation looks even much younger than the portrait represents him.

The Little Chief Hare.

BY J. H. BATTY.

But little is known of the strange little animal called by miners and hunters "Concy" and "Starved Rat," and by Audubon and others the "Little Chief Hare." It is found on the highest peaks of the Rocky Mountains, far above timber line, near the perpetual snow-banks, among the immense piles of loose volcanic rocks. Its note consists of a singlesqueak, which is quickly given at short intervals. The one from which the illustration is made was shot on Long's Peak of the Rocky Mountains, Colorado, by a member of the U. S. Geological Survey under Dr. Hayden. A few stragglers were first observed on Pike's Peak. As the party advanced westward near the snow ranges the Coneys became more numerous, and on Mt. Lincoln, Elk Mountains, and in Mosquito Pass they were seen in considerable numbers. When the note of the animal is heard it appears to come from a distance, although the animal making it may be but a few yards from the hearer. The favorite resort of the Coney is on some sharp projecting rock. From that elevated position it gives its faint squeak and immediately after disappears, and suddenly is seen on another stone a few yards from its former position, uttering its note as before. The Coneys appear to be most active at the commencement of a snow squall, when their squeaks may be heard in concert from many quarters. Although they appear to be fond of the snow, they seem to be greatly in dread of the hail-storms which are frequent on the mountain tops during the summer. The little Chief Hare is 7.75 inches long. Its head is large in proportion to the body, being 2 inches long and 1.62 inches wide. The eyes are small and dark hazel, set rather deep in the head. It has two incisors above and below, those of the upper jaw being so deeply grooved, nearly their full length, as to give it the appearance of having four incisors instead of

but two. The color upon the upper surface is dark brown, with irregular bands of brownish black running transversely across the back. The under surface is yellowish gray. The very small tail is light colored. This species was discovered by both Drummond and Nuttall in

with ground on all sides, it is well suited, when modified as required, for a corner or otherwise located plot in a village or city suburb; in that case the parlor and dining-room will face the street. The aim has been to produce a pleasing structure, and one that will be interesting

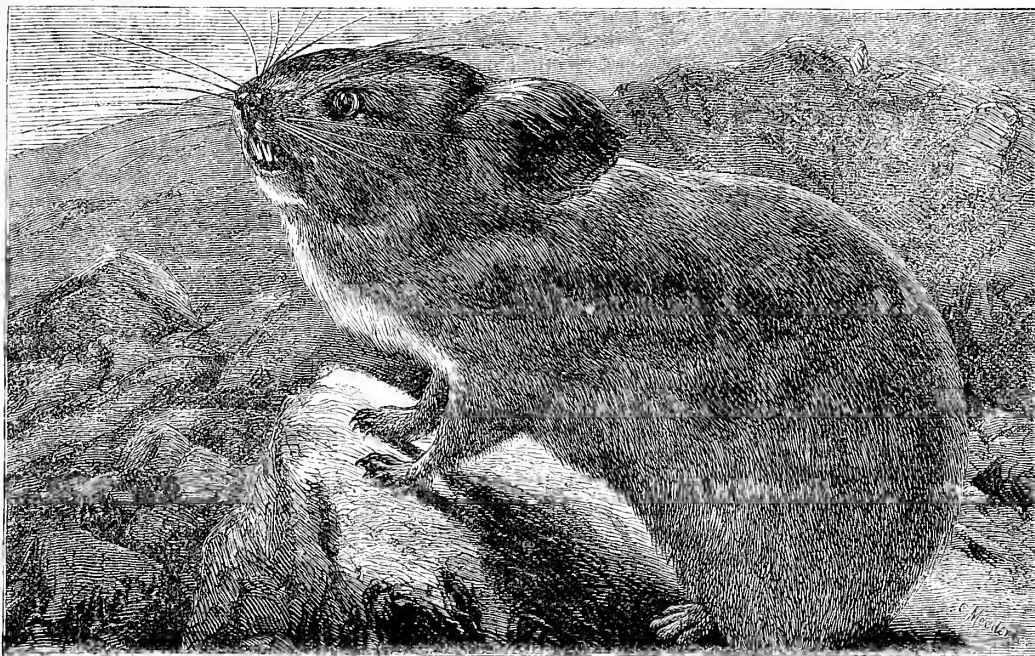

THE LITTLE CHIEF HARE.

their expeditions to the Rocky Mountains, but they give but little in relation to its history.

Design for a Cottage.

The elevation and plans here presented were furnished by C. A. Vanderhooft, designer, No. 191 Broadway, with the following description:

main building being 28 x 31 feet, with parlor extension 15 x 17 feet.

The first story is ten feet and the second nine feet high in the clear. A cellar seven feet high extends under the whole building.

The staircase window is a noticeable feature, being distinctively treated exteriorly in connection with the flower-stand and attic windows and gable, and while lighting and ventilating

the halls gives, by the introduction of stained glass in the upper panels, a constant delight to the eye at a small outlay. This can be dispensed with, but its introduction, together with the wood and iron finials, crestings, etc., should be looked at in the same light as the investment in a picture—a means of making home attractive. The arrangement of dining-room, bay, and fireplace will be found agreeable, as also the alcove on second floor. The dining-room and kitchen have large closets, and a pass window is provided from the rear hall into the latter. The kitchen is separated

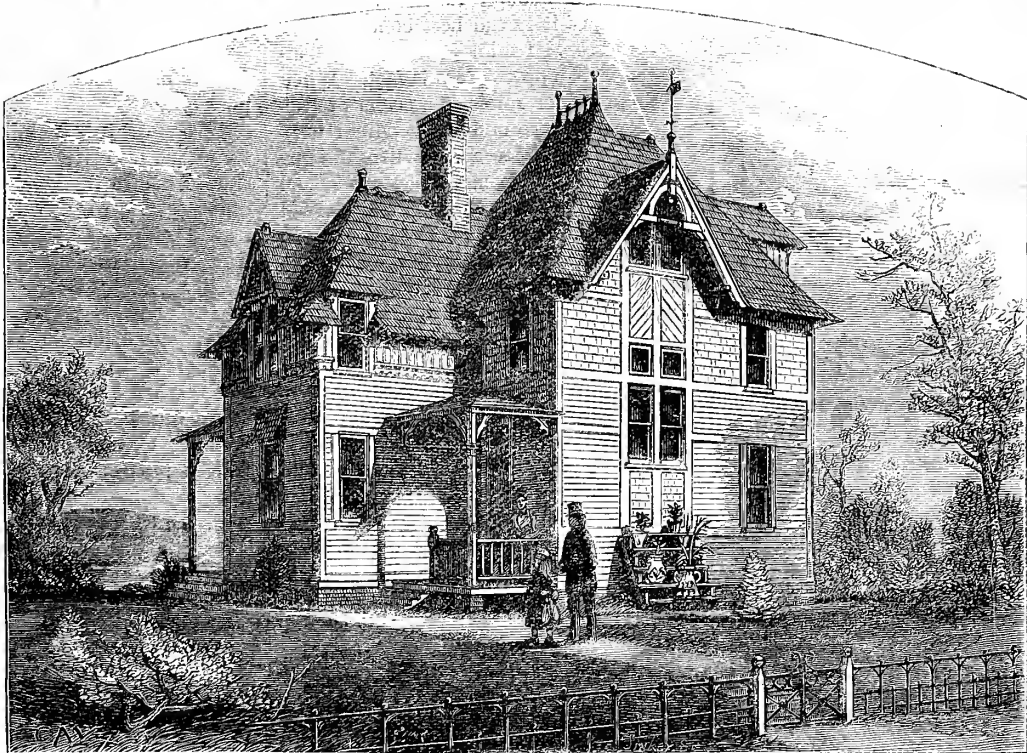

Fig. 1.—DESIGN FOR A COTTAGE.

The house here represented is suitable for a small family who desire a pleasant and convenient home, with some pretension to picturesque beauty, at a moderate cost, and will be found suggestive both in style and arrangements. Although designed for a special site,

is fitted up with range and hot and cold water. A wash-room can be added in the rear of the house if required, with servant's room over it.

The bedrooms are all provided with closets, and are conveniently arranged for the placing

the kitchen is separated by double doors from the rest of the house, and is fitted up with range and hot and cold water. A wash-room can be added in the rear of the house if required, with servant's room over it. The bedrooms are all provided with closets, and are conveniently arranged for the placing

of furniture. There is a servant's room in the attic, besides storage space and a tank to supply the boilers in the kitchen. A bath-room can be added by a slight change in the small bedroom, dispensing with the closets.

The main building is shingled on the second story, and covered with narrow horizontal weather-boards below, while the extension has

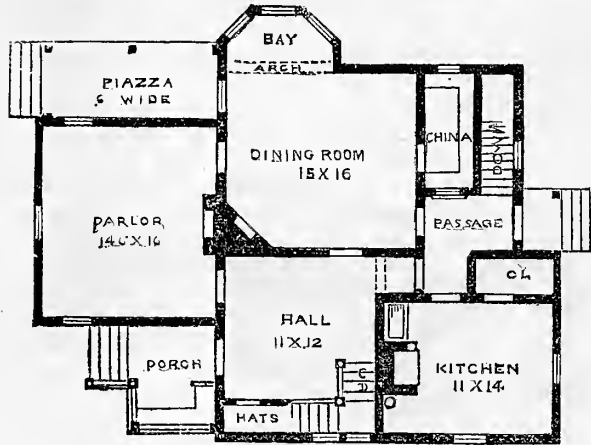

Fig. 2.—PLAN OF FIRST FLOOR.

vertical weather-boards under the eaves, as shown in figure 1, on the preceding page.

It is needless to repeat the mode of construction uniformly used in this class of buildings. The cost of this cottage built in the best manner, is estimated at \$5,000, depending, of

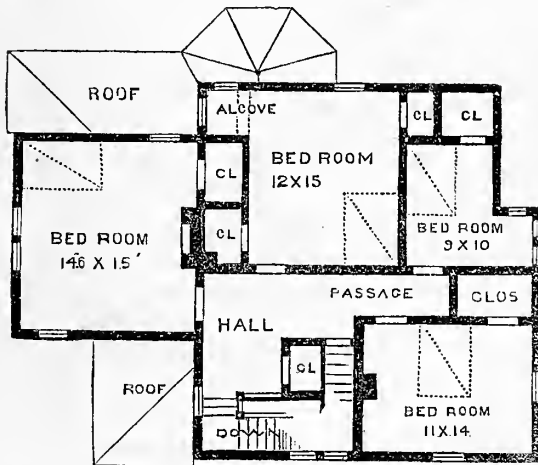

Fig. 3.—PLAN OF SECOND FLOOR.

course, on the locality and the quality of finish employed, and the specifications will necessarily be drawn up to suit the means and requirements of each individual.

Walks and Talks on the Farm.—No. 121.

The wheat in this section looked remarkably well last fall, and is gone into winter quarters in a most promising condition. The wheat crop last season throughout Western New York was the poorest we have had for several years. My own crop did not average over ten bushels per acre.

"Does it not dishearten you?" asks the Deacon, whose crop was not over five bushels per acre.

"No," I replied; "it is rather an encouraging fact than otherwise, for the simple reason that we farmers have to compete with each other. The stories that are often told about this or that farmer who scratched over a piece of land, sowed the seed, and harvested a big crop of wheat have a pernicious effect. They encourage a sort of gambling spirit among farmers.

We speculate on the seasons. We ignore science, experience, and observation. We hope for good crops without using the means necessary to secure them. It is a great evil."

"But I don't see," remarks the Deacon, "how a poor crop can afford you any encouragement."

"I will tell you, Deacon, where the point comes in. You have always contended that what is generally called 'improved farming' will not pay, that it requires too much labor; and you call attention to the fact that Mr. So-and-So raised a large crop by merely plowing his land and sowing the seed without manure. Now, of course, if this was a fair representation of the facts of the case, those of us who are endeavoring to cultivate our land more thoroughly are throwing away our time and money. We contend that there is a good and sufficient reason for these occasional big crops, and that they afford no evidence against the general agricultural law that good crops can only be produced by good farming."

Last year Ellwanger & Barry had 22 acres of choice white wheat that produced 43 bushels per acre. Meeting Mr. Ellwanger one day I asked: "What is there about that great wheat crop you raised last harvest?"

"Nothing but good culture," he replied.

"The land has been in nursery trees, and had been plowed deep and well cultivated. That is all there is about it. Farmers do not half work their land. That crop of wheat paid better these times than nursery stock."

That farmers do not half work their land is essentially true. We plow too much land, and do not work it enough to kill the weeds and put it in the best condition for the crop. I think farmers are beginning to appreciate this fact. When one farmer raises 45 bushels of barley per acre and his neighbor only 15 bushels per acre; when the former readily brings \$1.50 per bushel of 48 lbs., and the latter can be used only as food for chickens or the

pigs, and is dear at 50 cents per bushel, he is a dull man who can not see that it pays to farm well if it pays to farm at all.

"You seem to forget," says the Deacon, "that we are greatly dependent on the season. You appear to think that if we drain our land and make it clean and rich we are sure of good crops. But you ought to know better. Your Peachblow potatoes that looked so promising last summer proved to be a poor crop."

No one realizes our dependence on the weather more than I do. All I contend is that the better we farm the less likely we are to have our crops injured by drouth, insects, etc. I should have had a good crop of Peachblow potatoes if it had not been for a severe frost that completely killed the tops early in October.

"You will never raise good potatoes," remarks the Judge, "until you give up your plan of planting in drills. I always plant mine in hills 3 1/2 feet apart, just as I do corn, and I have never had a poor crop. This year I raised 125 bushels of good Peachblows from 96 square rods, or at the rate of 208 bushels per acre.

They had no manure except a handful of ashes, plaster, and hen-dung scattered on the hill."

The Judge is one of the best farmers in the neighborhood, and is particularly successful in raising good potatoes and getting good prices for them. He has customers in the city who take all he raises. I sold my potatoes this fall at 50 cents a bushel. He got 60 cents. I had three acres of Peachblows that produced about 100 bushels per acre; but there were only 75 bushels per acre of merchantable potatoes. It cost me about \$10 per acre to dig them. I presume it cost the Judge about the same. The cost and profits of the two crops would be about as follows:

Expenses per acre:		W. & T.	Judge.
Plowing, harrowing, rolling, marking, planting, and covering.....	\$ 8.00	\$ 8.00	
Seed	5.00	5.00	
Hoing, cultivating, etc.....	7.00	10.00	
Digging.....	10.00	10.00	
		30.00	33.00
Receipts per acre:			
75 bushels, @ 50c.....	37.50		
25 " @ 12 1/2c.....	3.12		
	40.62		
200 bushels, @ 60c.....		120.00	
8 " @ 12 1/2c.....		1.00	
		121.00	
Profit per acre.....	\$10.62	\$98.00	

The Judge seemed delighted with the above table. He has been complaining about high wages and low prices until he thought there was no longer any profit in farming. The Deacon recollected that his crop was no better than mine, and said nothing for some time.

The Judge remarked: "You have charged nothing for my 'guano.' That has more to do with it than you seem to think."

"Well, if we call that \$8 per acre there is still a profit of \$90 per acre."

"It did not cost half that," replied the Judge; "I prepared it myself in the winter when I had nothing else to do."

"I hope," said the Deacon, "you will own up for once that your plan of planting is a poor one."

"You planted in hills, Deacon," I replied, "and had no better crop than mine. And besides, I had in the same field with the Peachblows several rows of Early Rose, which were a good crop; and also several rows of Late Rose, which turned out wonderfully, both in quality and quantity. There was certainly over 200 bushels per acre. And yet they were planted in drills, and were treated precisely the same as the Peachblows. I suppose they had reached maturity before the frost came, while the Peachblows would have kept on growing for a month. The truth is that the Judge's potatoes were injured but little by the frost, owing to the sheltered position of the land. And I think this has far more to do with it than the manner of planting."

"J. B.," of Decorah, Iowa, writes that winter set in a month earlier than usual. The crop of corn was very poor. Hogs are numerous, and there is not corn enough to fatten them. Corn sells at from 35c. to 45c. a bushel. Hogs 3c. per pound live weight, or 3 1/2c. to 4c. dressed. Butter sold for 10c. a pound in summer, but since the drouth has advanced to 25c. per pound, and many farmers have to buy. "I was in town last Saturday," he writes, "trying to sell chickens, and all I could get offered was 10c. apiece, no matter how fat they were. I said, No; I will eat what I can, and the rest I will

winter over."—That is right. A fat chicken at ten cents and a pound of pork at four cents would not be a bad dinner after a few hours sharp work on a frosty morning.

"Steers are selling for 2c. to 2½c. per pound live weight; but," he adds, "I am sorry to say there are very few to call fat."—What is needed is a Shorthorn bull.

W. C. Cusiak, of Oregon, sends me by mail four pounds of Chili Club wheat. It is a handsome white wheat. It is usually grown as a spring wheat in eastern Oregon, but is often grown as a fall wheat in western Oregon. It came too late for me to sow last fall, and I have had poor success in raising spring wheat here. Mr. C. adds: "Farming is generally carried on here (eastern Oregon) in a slovenly manner. Grain all sown in the spring, as the ground is usually too dry to 'bring it up' in the fall. It is harvested with 'headers,' which leave all the weed-seeds on the ground. Consequently farms are running down. Land that produced 100 bushels of barley per acre ten years ago will now hardly produce 25 bushels."—This is the same old story. We must kill the weeds or give up all hopes of raising large crops of grain.

"J. H. M.," of Aaronsburg, Centre Co., Pa., writes that the general rotation in his neighborhood is: (1st) Corn on clover sod; (2d) oats; (3d) after the oats are harvested 12 tons of well-rotted manure per acre are spread on the oat-stubble and plowed in. After the oats come up the land is either plowed again or thoroughly cultivated, and is then drilled in with winter wheat. One quart of timothy seed per acre is sown in the fall and five quarts of clover in the spring on the wheat. The hay crop averages two tons per acre; corn, 90 bushels of ears; oats, 35 to 60 bushels; wheat, 20 to 30 bushels. Mr. M. asks if it would not be a good plan to fallow the land after corn instead of sowing oats. Put the manure on the fallow and sow wheat. Then sow wheat again the next fall.—As a rule I do not like the idea of sowing wheat after wheat. If the land is heavy and the oat crop uncertain, the plan of fallowing instead of sowing oats is a good one. But I would seed down with the wheat. And then, the next year or, still better, the year after, plow up the clover sod and sow wheat, seeding it down again in the spring. Or, what would suit me better, I would plow up the clover sod in July, August, or September, as most convenient, and "fall-fallow" it. And the next spring I would sow it to oats and peas mixed together, or to oats or peas alone, or to barley, and follow this crop with wheat and seed down again with clover in the spring.

"Does a crop of corn," asks a scientific friend, "impoverish the soil more than a crop of corn grown only for fodder and not allowed to go to seed?"

It is the general impression that such is the case; but I think there is little or no evidence to sustain the impression. It is thought that the production of seed draws heavily on the land. My own opinion is that the seed is elaborated from matter previously formed in the plant. It is the quantity of plant-food abstracted from the soil that impoverishes it; and, according to this idea, it would make very little difference whether this plant-food was concentrated into fruit or seed, or whether it remained in the leaves and stems of the plant. In other

words, a crop of oats cut for hay or green fodder a week or ten days before the seed was matured would impoverish the soil nearly or quite as much as if the crop was allowed to fully mature the seed.

When we allow a crop of timothy hay to get over-ripe, or, in other words, to form seed, there is probably a loss of nutriment. At any rate cows will not eat and digest this over-ripe hay as readily as they will hay that is cut before the seed is fully matured. But it is not clear to my mind that by letting the timothy go to seed you impoverish the soil. And so in growing corn for fodder I see no reason for supposing that it does not impoverish the soil nearly or quite as much as if we grew the crop for the sake of the grain.

"I don't believe any such a doctrine," remarks the Deacon. "Do you think your Northern Spy trees that produced such a grand crop of apples this year have not taken more substance out of the soil than if they had not produced fruit?"

"I suppose if they had not produced fruit they would have produced more wood. I think the roots would have taken nearly or quite as much water and plant-food out of the soil in the one case as in the other. The reason so many apple-trees bear only every other year is that during the "bearing year" the excess of fruit absorbs the material that ought to be stored up for the next crop. And this is my reason for thinning out the fruit."

"Yes, I know," says the Deacon, "but it is a good deal of work, and farmersean not spare the time to do it."

"It takes no more time to pick off a little apple in the summer than it does to pick the same apple in the fall—and with me the fall is the busiest season of the year. I got this idea from J. J. Thomas. I used to think, as you do, that thinning fruit was one of the refinements of horticulture which those of us who grow apples and peaches largely for market could not stop to bother with. But Mr. Thomas's remark above quoted convinced me of my error. If there are two thousand apples on a tree in the summer and I let them grow, I have to pick them all in the fall. If this is as many again apples as the tree ought to bear, the two thousand apples would fill say five barrels. Now, if I pick off one thousand of the smallest and poorest and specked and wormy apples in the summer, and let the sheep and pigs eat them up, the probabilities are that the thousand apples left on the tree would grow so much larger that they would fill the five barrels as before. We pick two thousand apples in either case, and get the same amount of fruit."

"What, then, do we gain?"

"In the first place, the thousand apples do not exhaust the tree as much as the two thousand. There is as much fruit by measure, but it consists largely of material that takes little from the tree or the soil. There is only half as much seed, etc. We ought to thin out at least enough to leave the tree strength enough to bear a full crop the next year. In the second place, the thousand apples are worth much more than the two thousand; and last, but not least, the trees will bear every year."

"That is all true enough, and you might put it still stronger; but do you mean to say that you can grow apples so big that two hundred fill a barrel?"

"When we were barreling our Northern Spy apples I had the curiosity to count how many

apples it took to fill a barrel heaped up ready for pressing. One of my men counted one barrel and I another. We did not select the largest, but about the average of the best fruit. My barrel took 222 apples and his 218 apples. I then told him to select out the largest apples, and we filled a barrel with 190 and another with 186 apples. The latter I headed up just as they were and sent to the editor of the *American Agriculturist*. I presume the railroad-people would do their best to bruise them before they got to the end of their 400-mile journey. [They succeeded too.—Ed.]

"An apple crop, like wheat, is a pleasant thing to have during these hard times. The money comes in a lump. I sold my apple crop all to one man, and drew them directly out of the orchard to the depot. They came to \$1,256.50. It is quite a help."

"It is so," said the Deacon. "You have no other four acres on the farm that will pay half as much. That orchard, the way you manage it, is good for a thousand barrels of apples."

I never knew the Deacon come so near paying me a compliment. I deserve no other credit than this: I had faith in good farming. I knew the Northern Spy was a very choice apple. I knew that in orchards as ordinarily managed it often failed to prove a profitable variety. Scores of farmers as they drove by have stopped and urged me to graft the orchard to Baldwins and Greenings. I said: "No. The Northern Spy is one of the best apples in the world, and of course, like all choice things, it requires the best of management. Neglect the orchard and you can not have a worse variety; treat it well, prune judiciously, and manure highly, and you can not have a better." There was a principle at stake, and I have waited patiently, and have not waited in vain. Several of the trees this year bore five barrels of the choicest fruit. I think when they get into full bearing they are, as the Deacon says, "good" for ten barrels.

I have now lived ten years on this farm, and have written "Walks and Talks" every month during this time. I feel somewhat ashamed to think how much of my purely personal matters I have presented to the public. I commenced to write without thinking; I told precisely what happened. Unfortunately, what happened proved to be largely mistakes and failures. I sent to Gregory, of Marblehead, for some seed of his best variety of onion, and sowed it on land that I should now think too poor to raise white beans and too weedy to sow to buck-wheat. You can imagine the result. My first crop of oats was eight bushels per acre, and of barley twelve bushels. Farming is slow work. I have not yet got my land anything like as clean as I want it. I keep working and hoping.—"Yes," says the Deacon, "and walking and talking."—Precisely. That is what I wanted to get at. I have told of so many disappointments and discouragements that while, as I said before, I commenced this series of articles little thinking that I should continue to write them so long, yet I do not know how to stop. I believe in farming, and feel sure that it can be made not only a pleasant but a profitable business. And if my land is getting cleaner and richer and my crops larger and more profitable I hope to be excused for saying so. I have told of my failures and the reasons for them. I want to tell of my successes—if I ever have any. I think the readers of agricultural papers do not need information so much as exhortation. What we need

is encouragement. We want to believe that good farming will pay—and it most certainly will. Or, if it does not, no other business in the community can long continue to prosper.

How Sleds are Built.

The best sled-runner is made from the butt of a tree. The grain where the root joins the butt

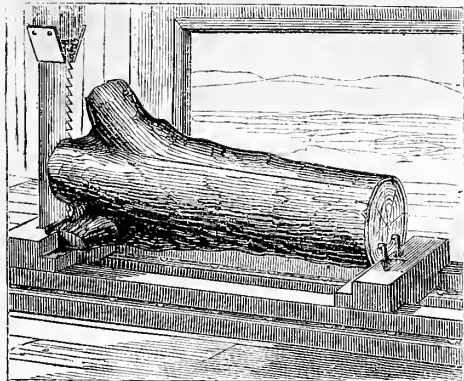

Fig. 1.—BUTT READY FOR SAWING.

is gnarled and twisted in such a manner that a runner cut therefrom can hardly be broken, and can not be split. But there is something in choosing the tree. Yellow birch, sugar maple, or white oak furnishes excellent wood for this purpose.

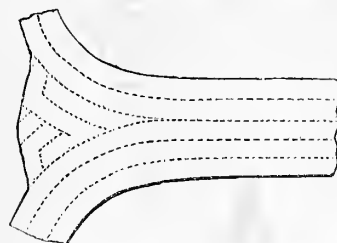

Fig. 2.—LINES TO SAW BY.

A good-sized tree with spreading roots should be selected; one which has two broad thick roots, one opposite to the other, and the stem of which suddenly thickens just above the curve of the roots, will be found the best. The main roots should be cut off a foot from the tree, and all others close to the stem; the earth should be dug

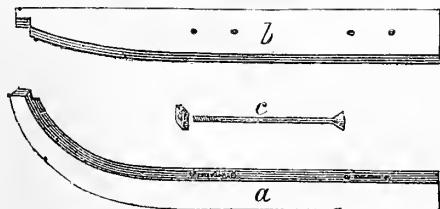

Fig. 3.—RUNNER, REVE, AND BOLT.

away from the tap roots and they should be cut. But very often it is not necessary to do this, as the tree will fall when the roots are cut all around it unless it stand very upright. The butt should be sawn off six feet long. In preparing it for sawing, it should be neatly trimmed, all earth and stones cleared from the crevices, and brought as nearly as may be

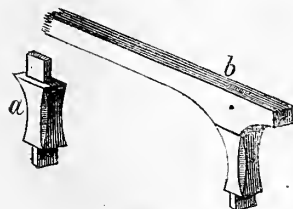

Fig. 4.—KNEE AND BENCH.

into the shape of that shown in figure 1, in which the piece is represented as fixed upon the carriage of a muley saw-mill. It is necessary that roots, as farmers often call them, taken to a mill to be sawn should be so prepared, as sawyers are otherwise averse to sawing them, often

refusing to do so, when they are useless, and the labor in cutting and hauling them lost. When properly sawn the planks, 2½ inches thick, appear as shown at figure 2, and the dotted lines there given indicate the form of the sled-runners to be cut from them. It will be seen that the waste timber at the lower part may be cut into knees, for which it is very valuable, having a grain exactly suitable for the purpose. They should be cut out so as to avoid cross-grain in any part. The runner is shown at a, figure 3, ready morticed for the knees. At b is seen the *reve*, or that piece which forms the side of the sled, resting upon the benches. This is cut to fit the point of the runner, and is secured there by a bolt passing through both parts. The *reve*, 1½ in. thick and 6 in. wide, is secured to the benches and runners by bolts passing through the shoe and runner on each side of the knees. The bolt shown at c, figure 3, is made flaring or spreading at the bottom to fit a corresponding countersunk hole in the shoe, and is secured above

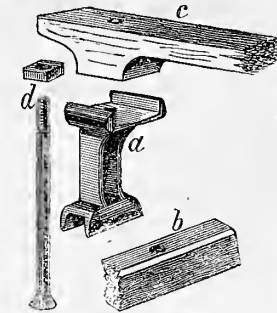

Fig. 5.—CAST-IRON KNEE, ETC.

snugly, flush with the surface. At each end of the bar screws are cut and nuts and washers are made to fit it. At c is shown the method of fitting the tongue into the roller, the tongue being tenoned and wedged therein very tightly. The roller and tongue as completed is shown at d. A brace is fastened upon each side, bolted to the tongue and welded to a band which embraces the end of the roller. At e is shown a plate to be fastened to the nose of the sled, as seen in figure 7, to prevent wear by the draw-bar. In this figure (7) is seen the sled completed before the tongue is fitted into its place. If the work is not very heavy the bolts passing through the runner and *reve* may be dispensed with and light carriage bolts used to fix the *reve* to the bench.

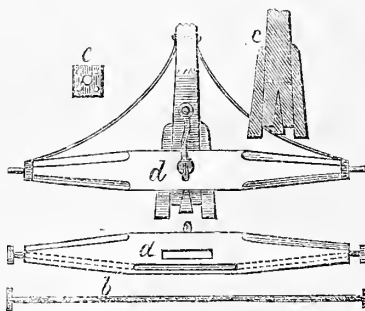

Fig. 6.—ROLLER, ETC.

the *reve* by a nut, which when screwed down tightly is fastened by riveting the end of the bolt; or in case one of the improved lock-nut bolts described in the *Agriculturist* of November last is used, the key is driven in, which holds the nut firmly. The form of the knee is shown at a in figure 4, and the bench at b. The joints of these parts should be made very close; each one be slightly draw-bored, and a bolt passed through each riveted at the end over a washer. The better these joints are made the longer the sled will last, as it is in these parts it first gives out. If the tenons are dipped in linseed oil when they are driven in the mortice, and the mortice also is painted over with the oil, it will add very much to the durability of the sled. At figure 5 is shown a new and very valuable invention—a cast-iron sled knee. It is patented and made by the Bradley Manufacturing Company of Syracuse,

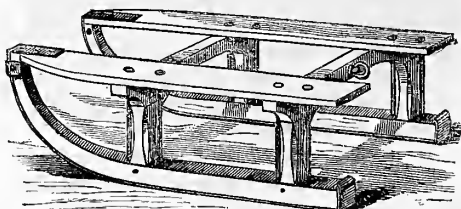

Fig. 7.—THE SLED PUT TOGETHER.

N. Y. This is a decided improvement, and one that will add much to the value of the

sleds in which they are used, and considerably reduce the cost. There are no mortices to be made, and it will be seen that there is no place in which wet or moisture can gather and rot the runner. Besides, by using these knees, almost any person can build a sled, while it needs at least a fair mechanic to build one with the ordinary knees. The cast-iron knee is shown at a, the runner at b, the beam or bench at c, and at d the bolt which binds the whole together. The form of the roller is shown at a, fig. 6. This should be made of a straight-grained piece of hard maple or birch timber, 6 in. wide by 4 in. thick, reduced to the shape here shown. A mortise is made through the center to receive the end of the tongue. Holes are bored from the center of each end, running out at the middle of the roller in which the draw-bar b is placed. A channel is dug out at the middle of the roller in which the bar lies

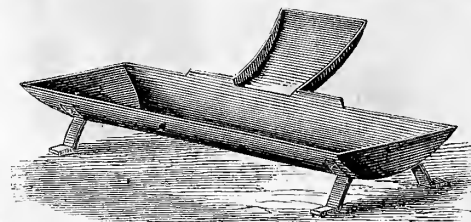

Fig. 1.—MR. CURTIS'S PIG-TROUGH.

snugly, flush with the surface. At each end of the bar screws are cut and nuts and washers are made to fit it. At c is shown the method of fitting the tongue into the roller, the tongue being tenoned and wedged therein very tightly. The roller and tongue as completed is shown at d. A brace is fastened upon each side, bolted to the tongue and welded to a band which embraces the end of the roller. At e is shown a plate to be fastened to the nose of the sled, as seen in figure 7, to prevent wear by the draw-bar. In this figure (7) is seen the sled completed before the tongue is fitted into its place. If the work is not very heavy the bolts passing through the runner and *reve* may be dispensed with and light carriage bolts used to fix the *reve* to the bench.

Cooking Room for Pig-Pen.

In the *Agriculturist* of December, 1873, we described an improved pig-pen. We here give

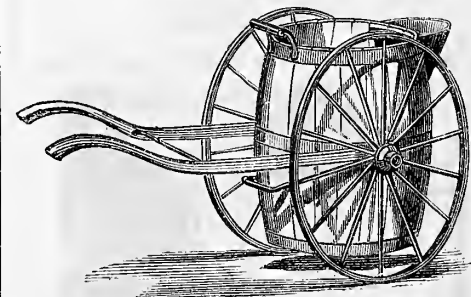

Fig. 2.—FEED BARROW.

an engraving (figure 3) of an arrangement for cooking the feed suitable for such a pen as that referred to. The room should be fitted at one end of the row of pens, unless that is too long, in which case it would be better to have it in the middle. The boiler is of cast-iron, and is built around with brick; underneath it is the fireplace and ash-pit, from which a flue or smoke-pipe passes into the chimney. This is a very convenient and economical arrangement for preparing food when it is desired only to scald it and allow it to soak and swell. For cooking whole grain or potatoes or roots it

will be found very desirable and economical in the consumption of fuel. With such a boiler we would not attempt to boil the food for any length of time, but after bringing it to the boiling point we would simply maintain it

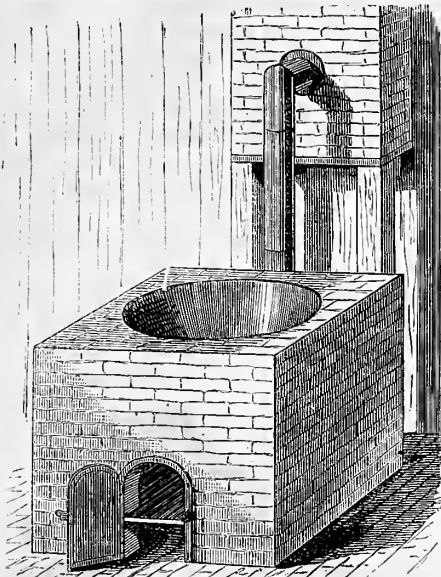

Fig. 3.—BOILER FOR COOKING FEED.

there as nearly as possible by covering up the boiler and allowing the feed to soak. Cooked in this way whole grain may be fed as economically as if ground, and the cost of grinding which is saved will more than pay for the cost of cooking. The feed barrow (figure 2) is adapted for using cooked food. It is a barrel or a barrel-shaped tank hung upon a bent axle and a pair of wheels. It is furnished with a spout or lip and handles, by which it may be tilted and the feed poured into the troughs.

Figure 1 represents an ingenious and indestructible pig-trough, invented by Mr. F. D. Curtis, the very active and enterprising vice-president of the New York State Agricultural Society, for use in his pig-pens. It is made of cast-iron of the thickness of stove plate, weighs about 100 pounds, and costs about five or six cents a pound. It is not patented, and any person may have it made at any foundry. The feet upon which it stands are either cast or may be made of bent strap iron and attached to the trough by a few screws or rivets.

A Barn Cistern.

"A Subscriber" may construct an elevated

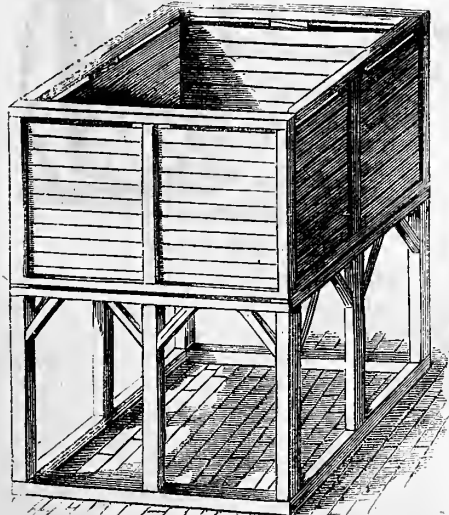

A CISTERN FOR BARN.

barn cistern without difficulty and at moderate cost in the following manner: A frame of stout

timber, proportioned to the size of the cistern and the weight of its contents (10 × 10 oak timber would be suitable for one 12 feet square), is constructed either in the corner of the barn itself or outside of it at one corner; the southwest corner being preferable as being most sheltered from the cold and most exposed to the sun. This frame should be large and high enough to answer for the cooking room for the feed. Above it is built the frame of the cistern, which consists of three cross sills, two end sills, and eight posts; that is one at each corner and one in the middle at each side. These posts are framed into the four cap-pieces and the whole is strongly pinned together. The floor and sides are made of tongued and grooved plank two inches thick. Each joint is smeared with pine-tar when it is put together, and the corners are especially well fitted and caulked. When the cistern is put together the sides are made to fit closely by means of wedges driven between the edges of the upper planks and the cap-pieces. This is shown in the above engraving. A triangular-shaped piece of scantling should finally be nailed in each corner, fitting closely in its place. A cistern 12 feet square and 8 feet deep will hold about 250 barrels or 8,600 gallons. The frame of the cistern should be made at least two inches smaller each way than the frame of the room below. Then the whole is boarded up and a tight roof built over it. If the room below is used for a cook room the waste heat and steam from the boiler will ascend and pass around between the walls of the cistern, the outside boarding, and gather or escape at the roof. This will enable the cistern to be kept in use during the winter without freezing, except in localities where the cold is very intense, in which cases it would not be judicious to use it at that season. The pipe from the cistern passes through the bottom. The waste pipe from the top should pass into a drain below, and the gutters from the barn, of course, should lead into the cistern beneath the roof. A cistern of this character is well adapted for use along with the cooking arrangement described in another article. On the whole, we would prefer the cistern to an underground one in which a pump must be used.

Two Useful Instruments.

The accompanying engravings represent two very useful although common-place instruments. Fig. 1 is an improved rubber designed to take the place of the currycomb. To many horses the use of the currycomb is a very painful infliction, and after all it does not serve the purpose intended so well as it ought to do. This improved rubber will answer all the good purposes of the currycomb without possessing any of its evil qualities. If used against the direction of the hair it will loosen and remove dust and scurf very effectively, and the friction will be agreeable and healthful to the skin. It is patented, but sold at the reasonable price of 25 cents. Fig. 2 represents a very convenient brush which will be found useful in the stable for the purposes for which the stiff and unne-

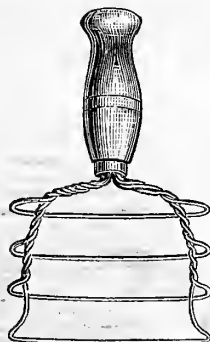

Fig. 1.—RUBBER.

cessarily rigid wire card is now employed. It is less harsh to the skin of the horse than the card, and will clean equally well. Being made

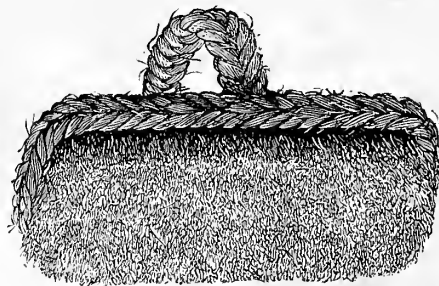
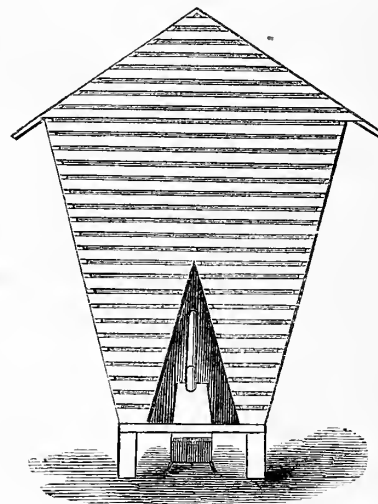

Fig. 2.—RATTAN BRUSH.

of split rattan it is flexible and fits the hand easily, and is not softened by water nor will it wear away rapidly. It is sold in the stores for 15 cents. It will be found a very efficient scrubbing brush for the kitchen.

Kiln-Drying Corn.

By a small expenditure of labor and fuel corn may be made ready for market or the mill in a few days after it is husked. For this pur-



CRIB ARRANGED AS A KILN.

pose we have used the contrivance figured in the annexed engraving. The bottom of the crib was made with two sloping lathed sides, instead of being of boards and flat, as has been previously described in the *Agriculturist* (September, 1871), and which in itself very much aids the drying of the corn. The space below the crib was closed in by nailing boards upon the posts, and a common sheet-iron stove was put into it. In a week, with the expenditure of a quarter of a cord of fire-wood, a crib of corn of 800 bushels was made sufficiently dry for grinding. Upon our suggestion a neighbor who had watched the process above described made a rough crib of boards and rails of a somewhat similar shape to that in the engraving, in which he dried 2,000 bushels of corn ready for market in two weeks, keeping the fire going only during the daytime. The advantage of this process of kiln-drying is that the corn is ready for sale long before it would otherwise be, and can be shelled and turned into cash much sooner, which is very often a great convenience to the farmer never or rarely overburdened with funds.

COTTON-SEED CAKE MEAL.—Dr. Voelcker recommends as a feed for fattening stock in summer a mixture of three parts of corn-meal with one part of hulled cotton-seed cake meal

finely ground, and in winter two parts of corn-meal with one part of the cake meal. When fed alone the cake meal has been found to contain too large a proportion of nitrogenous matter for the health of either cattle or sheep, but when mixed in the above proportions the corn helps to dilute the cotton-seed and render it digestible and healthful. For sheep a daily feed, of half a pound per day, has been found very useful, especially when a flock is pastured upon dry, poor pastures; but it is very necessary that an abundant supply of drinking water be provided for them.

What Crops Leave in the Soil.

Amid the weariness of all that is written about what crops take from the soil, of how they rob it of the ability to produce succeeding crops, it will be a relief to look at the other side of the question and consider what they leave in the soil, and how they add to its future producing power.

The following is a statement of the results of instructive experiments made in 1869 at the experimental agricultural station of Proskau, in Germany, by Doctors Weiske & Werner. They selected given areas in different places in each of several fields in which various crops had been grown. These they dug out to the depth of ten inches, carefully washing out the soil, and weighing and analyzing the stubble and roots remaining. The following table shows the figures, calculated in English pounds, per English acre:

STUBBLE AND ROOTS REMAINING AFTER HARVEST.

	Total Dry Substance.	Organic Matter.	Ash.	Nitrogen.	Potash.	Phosphoric Acid.
Lucerne.....	9702	8498	1204	137	37	40
Red Clover.....	8953	7026	1927	193	82	75
Sainfoin.....	5952	4925	1027	124	48	30
Peas.....	3234	2569	674	57	11	15
Buckwheat.....	2203	1736	467	48	9	11
Rye.....	5283	3630	1653	66	32	26
Wheat.....	3490	2396	1094	24	19	12
Oats.....	3792	2343	1449	27	25	30
Barley.....	1999	1617	382	23	10	12

These figures, relating to a single experiment, are, of course, of only general value; at the same time they are, in a general way, very useful. They show, for instance, that the more delicate-rooted grain crops leave comparatively little residue in the soil—barley less than 2/5, as much as rye, and only about 1/5, as much as red clover, which, in return for its few quarts of seed, after having yielded an abundant crop, leaves for the enriching of the soil about 4 1/2 tons of root and stubble. Nor is the total amount of material left in the soil of more consequence than the quantity of particular elements? Red clover leaves 193 lbs. of nitrogen, while wheat leaves only 24 lbs. The former leaves more than four times as much potash and more than six times as much phosphoric acid as the latter.

These comparisons sufficiently explain the great and well-known value of clover as a preparatory crop for wheat and for all other crops which are not manured with nitrogen, potash, and phosphates. In the field on which this examination was made, the clover of an acre left nitrogen enough for 116 bushels of wheat, phosphoric acid enough for 114 bushels, and potash enough for 73 bushels. It should be remembered, too, that most of this material is left in the best possible condition for use—as a part of readily decaying roots well distributed

through the soil and penetrating it to a considerable depth. Indeed, particularly in the case of the clover, there would be a very considerable amount of root below the ten inches, to which only the investigation was carried.

Whether (as is unknown) the nitrogen of the clover comes wholly or partly from the soil or from the air, it is certainly taken from a condition in which it is of little use to most crops, and is converted to an available one; so that, practically, the clover is a creator of nitrogen in the soil, as it is an efficient purveyor of its latent supplies of potash and phosphoric acid.

Root crops were not included in the examination, but it is well known that they leave in the soil only a few fibrous roots, which can add but little to its stock of fertility; and experience teaches that, of all our crops, roots (unless fed off upon the land) are the most exhausting. A corresponding result would be found to obtain in the case of Indian corn. In fact, the value of any crop to the crop which follows it is found in practice to be very nearly what the above table would indicate, except in the case of oats, which injure the soil by mechanical action, their roots "clodding" the ground into lumps. This crop is more deleterious than barley, although leaving more residuum in the soil.

A Cover for Corn-Cribs.

It is not probable that corn will long remain at its present low price. It may soon be the case that it will be worth caring for and preserving from the weather. A vast quantity is destroyed or badly damaged by being exposed in open cribs to the rains and snows of the winter and spring. A simple and very cheap method of protecting the log or rail crib in

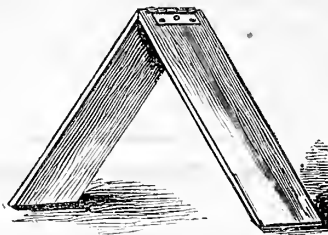

Fig. 1.—BOARD RAFTER.

common use in the Western States occurred to us as we saw hundreds of them filled with corn soaking in the heavy rains of last spring. We would take two boards six feet long and fasten them together at the end by leather or iron strap hinges, as shown in the engraving (fig. 1). These should then be laid across the corn, which is to be heaped up into the center of the crib; as many pairs of these boards being used

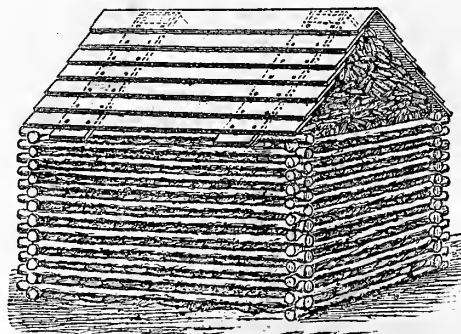

Fig. 2.—COVER FOR CORN-CRIB.

as may be necessary for the length of the crib, or two pairs for each length of boards, whether that be 12 feet or 16 feet, or less. Then boards

are tacked lengthwise of the crib, upon those hinged together, and which serve the purpose of rafters, commencing at the lower part, and making each board overlap the preceding one two inches or thereabouts. The nails should be only partly driven in, leaving the head projecting a little, so that when the cover is to be taken away the nails are easily drawn out with a claw-hammer. Figure 2 shows a log-crib covered in this manner. It will, of course, be necessary to stay the cover by some means so that it may not be blown off by heavy winds.

Timber Tongs.

The annexed engraving represents an implement for handling heavy timbers, or by altering the shape somewhat it may be made very

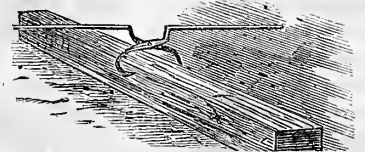

TIMBER TONGS.

useful in picking up large stones which might otherwise be difficult to handle. It should be made of three-quarter inch iron bar flattened out where the tongs are pivoted together and also at the jaws. The points of the jaws should be steeled, and brought to a sharp flat point beveled on the lower side, so as to grip the timber or stone without slipping. Two pairs of these tongs would be found very useful on a farm for picking up and carrying fence-posts, timber, or stone, or in taking hold of old posts when they are to be drawn out of the ground. For use in saw-mills they will be found especially handy, and those of our readers who are engaged in country saw-mills will find them, once used, to be indispensable.

Steam on the Canal.

So far as engineering difficulties are concerned the experiments of steam carriage upon the Erie Canal have been crowned with success. It only remains now to adapt the capacity of the canal to the new method of propelling canal boats, and make such changes as shall permit the new system to become inaugurated without interference with old and conflicting interests, to immediately increase four-fold the usefulness of this outlet for the products of the West. As it has been found as the result of the recent experiments that a steam-propelled boat can make the trip in half the time required for a horse boat, and that the cost per day is reduced one-half, it is very clear that the usefulness of the canal is quadrupled.

The *City of New York* is the name of the new boat which has accomplished this result. She is 98 ft. long by 17 ft. 4 in. in width and 9 ft. 9 in. depth of hold, and carries 220 tons or 7,000 bushels of grain. She has an engine of the best modern construction, and her consumption of coal is only 17 pounds for each mile traversed. Her trial trip from Buffalo to New York occupied less than eight days, with 36 hours lost by detentions exclusive of time spent in the locks. Her speed for the entire trip was over 3 1/4 miles per hour, or more than double that of the ordinary boat. The cost of her trip amounted to 17 1/2 cents per mile, which is about half that of the present horse boat. There are also other items of saving of expense,

such as towage upon the river and at New York; and in addition, as the boat may be of service after the canals are closed, the expense of her annual maintenance need not be condensed into the actual season of work upon the canals. It may be that there are still further improvements possible in this link of Western transportation; but if nothing further is achieved the cost of transit for a bushel of grain between the foot of lake transportation and the head of sea transportation may doubtless be reduced 75 per cent, and by so much the Western farmer's pocket will be enriched.

When to Flow Cranberries to Kill Worms.

We have received the following statement from a gentleman who has a plantation of cranberries at Thom's River, N. J., which, as it contains the record of a common error and consequent failure, will be interesting to many of our readers: "I cleared up eight acres of swamp five years ago, built two dams, carefully cultivated, and in due time the vines covered the marsh, and last June the blooms literally covered the vines, giving promise of richly rewarding me for all my labor. I saw some indications of the worms webbing the vines on the 4th of July. I immediately stopped the water on the upper piece for 24 hours, and then let it on to the lower the same length of time; but a short time after I perceived that what the worms had not destroyed the blight from some unknown cause had. So I only got 17 barrels where I should have had 200 at least. The worm looks like an apple-worm, and webs the tops of the vines together and kills leaves and blooms. I perceived some of them this fall as I was cleaning them out. How would it do to hold the water on the vines until May 15th, and then flood them once a week for twelve hours until June 15th, and then flood them twice a week until July 15th?"

This vine worm of which our correspondent speaks is the "*Tortrix vaccinivorana*, or the Cranberry-destroying Leaf-roller," so called by Dr. Packard in his work, Guide to the Study of Insects. It feeds naturally upon the huckleberry, and possibly upon other members of the heath family, and for this reason it is exceedingly desirable that huckleberry brush should be cleaned up and destroyed in the vicinity of a cranberry bog. The insect is known under the various names of "Web-worm," from the web which it spins, the "Fire-worm," from its destructive effect upon the vines, and "Vine-worm." The parent of this worm is a small cream-colored moth without any distinct markings. When at rest it is about one-fourth of an inch in length, and expands about one-half an inch. The moth survives the winter, finding shelter upon the vines and under the bark of trees, in bunches of weeds and grass, and especially in turf fences such as are often left around the borders of cranberry plantations. The moths which survive the winter mate and deposit their eggs on the leaves of the cranberry vines from the middle of April to the 1st of May. In a week or ten days the eggs hatch, and the worms begin to feed on the under side of the leaves. In a few days more they begin to make their web and draw the tops of the vines together. It feeds for about three weeks, becomes a chrysalis, and by the tenth of June a moth appears, and after a few weeks spent in mating and lay-

ing eggs a second generation of the larvæ appears about the second week of July. When the season is favorable, and there is no hindrance to their work, they will very soon destroy that portion of the cranberry meadow which they attack. The remedy for this pest is seasonable flowage, which our correspondent seems to have neglected. In the first place, the banks of the cranberry meadow should be cleaned of all brush, trees, and turf fences in which the moths can find lodging during the winter. Then the vines should be flowed to a depth of thirty inches from the 1st of November to the 10th of May. This will make sure of the destruction of all moths that may have taken refuge in the vines in the fall, and prevent the depositing of the first brood of eggs. It is a good thing for the vines to have the benefit of the sun for two or three weeks in May. Then about the 25th of May the water should be put on again and kept on for five or six days. This will destroy the second brood of eggs if any moths should come in from the neighboring brush or vines to lay them. If these two broods of worms are destroyed there is not much danger for the rest of the season, and we are inclined to think the water after the 1st of July does more harm than good. While the vines are in bloom and the young fruit is setting the water must be injurious. It is settled in the experience of our best cultivators that water is a complete remedy for this pest, where the flowage is entire and no other plant-food for the insect is allowed to grow near. But if a part of the bog remains uncovered, and the moths find a refuge, they will not only hold their own, but make inroads upon the part that is flowed. The blight of which our correspondent speaks is either the result of his mid-summer flowing, or, more likely, the scald, which is the greatest trouble now with the New Jersey cultivators, and which seems to be imperfectly understood. It is the special affliction of new plantations. After the ground is completely covered with vines there is much less of this difficulty.

American Potatoes in England.

The attitude of the English in regard to our American varieties of potatoes is something that quite passes our comprehension. They are written down as absolutely worthless, and yet the prize lots at the exhibitions consist largely of American sorts. Writers for the English press condemn the varieties over their own signatures, and the very same men write to our dealers for prices by the large quantity. We say we do not understand it, as we dislike to think that national prejudice can have any influence in so important a matter. The question of the excellence of some, at least, of our varieties of potato would seem to be effectually set at rest. Last fall Messrs. B. K. Bliss & Sons sent a collection of our potatoes to Dr. M. T. Masters, editor of the Gardeners' Chronicle. Upon October 7th that gentleman wrote to the Messrs. Bliss as follows:

"Last year you were good enough to send us for trial some of your new kinds of potatoes. As a large trial of over 300 sorts was projected to be carried out at the Royal Horticultural Society's garden at Chiswick this season, I thought the fairest way would be to send your samples to be tried with the rest. I sent them under numbers, so that no one but myself knew either the names of the varieties or the

senders. I have now the pleasure of telling you that a first-class certificate was awarded by the judges to your *Extra Early Vermont* and to *Vermont Beauty*. No doubt you will obtain official notice of this ere long; meanwhile, I thought you would like to know how much appreciated your potatoes were."

This certainly is a fair test, and should put a stop to the depreciation of American varieties in the lump. We may add that the "Vermont Beauty" has not yet been put in the market; we understand it is to bear the name of "Brownell's Beauty." It is a potato of excellent quality, and the handsomest one we ever saw.

Two Crops at Once.

BY PETER HENDERSON.

There is always some new idea coming up in the cultivation of the soil, originating frequently by accident, and quite often by those who have not made the work of the farm or garden the study of their lives. A case of this kind came under my observation last week, wherein a gentleman living in the upper part of New York Island, and cultivating but a small garden patch behind his house, discovered that to utilize his small space he could sow his "Little Gem" peas, and carrots, beets, or parsnips at the same time—in fact, in the same row, two feet apart. The peas, of course, came up boldly, seemingly leaving the more tardy root seeds so far behind that they would be no more seen. Not so, however, for soon as the peas were matured for use, clustering among the stems came the feeble seedlings of this second crop. The "straw" of the pea crop was carefully removed on a cloudy day, so as not to have the sun burn up the then unshaded seedlings of the root crop. A few days' exposure to sun and air, and they were thinned out to the usual distance of three or four inches, and by fall the crops of carrots, beets, or parsnips were just as good as if they had had the space entirely to themselves, or that the first crop of peas had not been taken. Market gardeners, who usually occupy valuable land, are obliged to resort to every possible expedient to keep the land earning something all the time, and they make it produce two and often three crops in a year.

Native Races of Sheep.

As a general rule, the sheep that we have imported hither from England have not been found to thrive. The pure-bred races of Leicester, Lincoln, Cotswold, and South-Down which have been imported have, with few exceptions, deteriorated. The greatest number of exceptions have occurred with the South-Downs, and the Leicesters have been, we believe, in every case complete failures. The English method of close breeding and high feeding is perhaps somewhat to blame for these unsatisfactory results, but the difference between the climates of that country and this is one very sufficient cause, and another is the difference between the two methods of feeding. The first difficulty, that of climate, is insuperable. The second, that of feeding, is also so in a great measure, because that depends upon the crops we raise for feed, and our crops are a necessity of our climate. But no country in the world has better opportunities of raising in a few years such varieties of sheep as are suitable to our climate from the material at hand in the most suitable

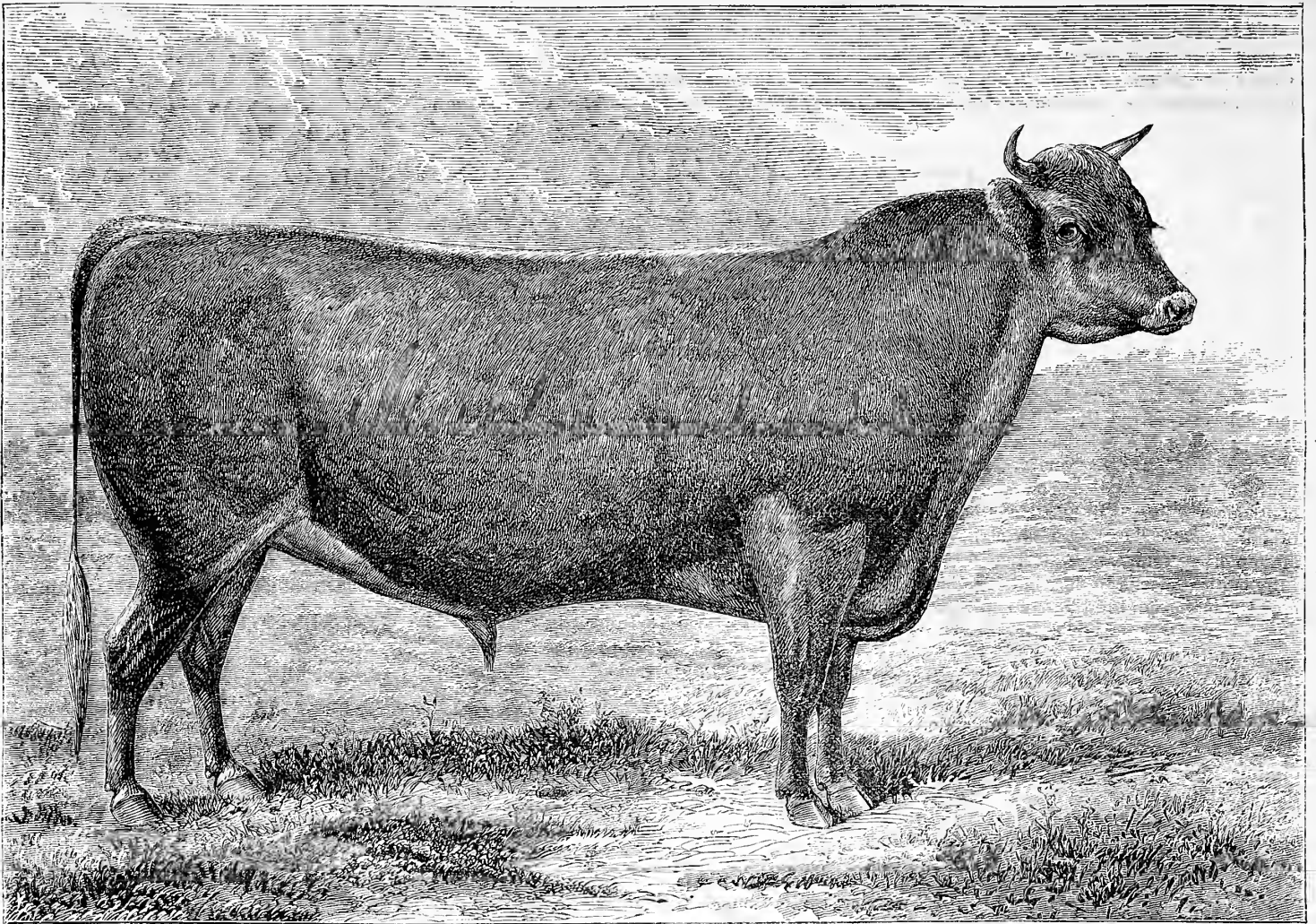

[COPYRIGHT SECURED.]

BULL BEACON COMET.—PROPERTY OF WM. CROZIER, ESQ.—*Drawn from Life and Engraved for the American Agriculturist.*

of the foreign breeds than we have. We are fast becoming mutton-eaters, and would consume much more were that sold in our markets worthy the name of mutton. We can produce fat, but meat is what is wanted. Thin Leicester or Cotswold mutton is not inviting, and when fat it is not desirable. Yet we have produced some very fair grades of these varieties upon common native sheep in which there is some merino blood, which have made very passable mutton. We think it is unquestionable that within reach of the great Eastern meat markets it would pay farmers to devote their attention to producing a class of sheep which should give a carcass of 100 pounds without being overloaded with fat, instead of the wretched mutton which now mostly comes to market weighing about 10 or 12 pounds or less per quarter. Grades of the English Downs—South-Downs, Hampshire and Shropshire Downs—sheep with black or smutty faces and hardy constitutions, with medium wool closely packed upon the body and impenetrable by rain or snow, and therefore affording that protection the want of which in the long-wool sheep is a serious and a damaging objection to them; and, most important of all, producing a sweet-flavored, juicy, and acceptable mutton. These are the sheep which furnish the best foundation upon which to build up a race of American sheep able to live upon our comparatively scanty pastures and withstand our summer heats and winter colds. But whatever race of sheep our farmers select as the basis of their flocks, we can never produce highly-flavored mutton nor full-fleshed

sheep without the aid of roots and crops of rape, tares, and clover for forage. Corn will make fat, but not meat, nor does it make an even stapled, sound, or lustrous wool; and in endeavoring to raise sheep upon dry, bare pastures and corn is precisely where we fail.

Polled Cattle Herd-Book.

The breeders of Norfolk and Suffolk red polled cattle in England, we read, recently met for the purpose of establishing a herd-book for that class of stock. A standard description was agreed upon, a committee of revision was appointed, and it was resolved to ask the assent of the various agricultural associations and cattle clubs to the standard adopted. This standard is as follows: A superior animal must be of a deep red, with udders of the same color; nose not dark or cloudy; tail may be white at the tip. Form: a neat head and throat; a full eye; a tuft of hair or crest should hang over the poll; the frontal bones should contract somewhat above the eyes and terminate in a narrow prominence at the poll or summit of the head. An imperfect standard includes those having the belly or the udder white, but no semblance of a horn can be admitted. Animals answering to this standard, which were in existence on January 1st, 1873, may be entered in the first issue of the herd-book. This, then, is the way in which an English herd-book is proposed to be established. The necessity for any inquiry into the history of the animals to be entered seems to

be ignored. Thus an accidental polled animal, if of the right color, may gain entry, although its sire or dam may have been horned. We have raised exactly such an animal as would have met every requirement of a superior polled cow mentioned in this standard, whose sire was a grade Shorthorn and whose dam was a black native cow. Such a cow, it seems, would be admitted into this herd-book as a thorough-bred red polled cow without question. As we have a direct interest in this matter, growing out of probable importations of this stock into the United States, we caution our farmers to put no faith in such a registry as this, and not to be led into supposing that an imported herd-book red polled cow or bull will mean any more than a red, hornless animal.

Beacon Comet 8th.

The above engraving is a portrait from life of the fine young Jersey bull "Beacon Comet 8th," the property of Mr. Wm. Crozier of Beacon Stock Farm, Northport, L. I. He is a descendant of Beacon Comet, and inherits the good qualities of his sire in a remarkable degree. One of his most striking peculiarities is his marking, which consists of beautiful dappled spots placed very symmetrically in almost regular lines from his back down his sides. His skin is very fine and mellow, and his handling is especially good. For want of space we are obliged to give some items relating to his history and performances in our "Basket" columns; to which we refer our readers.

Indian Tobacco—Lobelia.

There are in this country more than a dozen species of Lobelia. Some of them, like the Cardinal-flower, are conspicuous, while others

upon this point are needed. The name Lobelia was given to the genus in honor of a Flemish herbalist, De l'Obel. Some of the quack doctors, thinking it means *low*-belia, give to the tall-growing Cardinal-flower (*Lobelia cardin-*

to the Gulf, there are found five other species, some of them generally distributed and others quite local. All these species have in common with the northern one tubular leaves, but they vary much in size and form. The leaf consists



INDIAN TOBACCO.—(*Lobelia inflata*.)

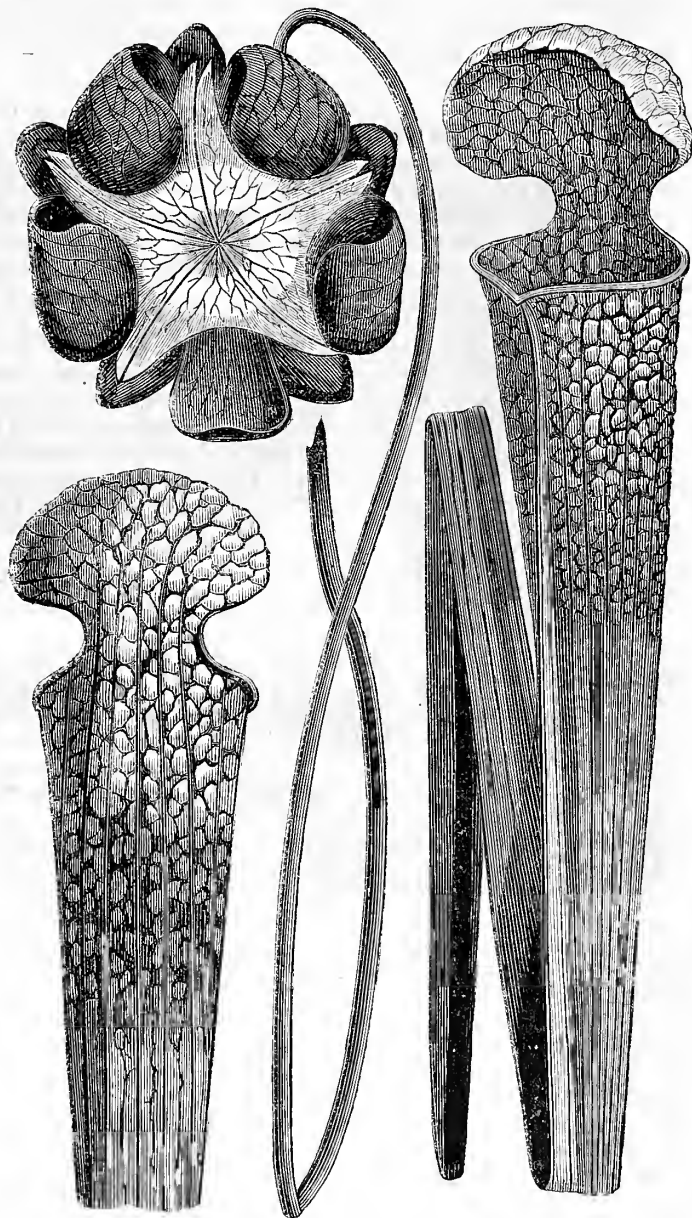

DRUMMOND'S PITCHER PLANT.—(*Sarracenia Drummondii*.)

are not at all showy. Several of the exotic species are among the valued plants of our gardens and greenhouses. The one here figured, *Lobelia inflata*, or Indian Tobacco, is on account of its active properties perhaps more common than any of the others, and is generally known as Lobelia. It is a much branched plant, common in fields, and has such small blue flowers that it is not likely to attract much notice. When the seeds begin to ripen the pod swells so that it and its inclosing calyx have a bladdery or blown-up appearance, which gave rise to the specific name *inflata*. This species possesses powerful medicinal properties, it being in large doses actively emetic and narcotic. It is used by physicians, and has long been one of the unsafe agents in the hands of quacks. Its activity is such that it should only be employed when prescribed by a physician. It is of interest to the farmer as being one of the several plants to which the "slaving" of horses is attributed. Being quite common in pastures, especially in autumn, it is readily accessible to horses; but we have no positive proof that they ever eat it, and observations

alis) the distinguishing name of *high*-belia. It is one of the easily determined plants, on account of the inflated character of its seed vessels, and one can easily recognize it from our engraving. It is an annual or biennial, growing from a foot to eighteen inches high, and found in late summer throughout most of the United States.

Southern Pitcher-Plants.

In the Northern States we have one species of Pitcher-plant which extends into Canada and Newfoundland and west to Minnesota. It was the first species described, and in honor of a French Canadian physician, Sarrazin, was named *Sarracenia*, with the specific name *purpurea*. This species is a well-known inhabitant of bogs and swampy places, and is sure to attract attention by its cluster of nearly prostrate tubular leaves and its curiously shaped flowers. It was figured in this paper in May, 1866. Besides the common name of Pitcher-plant, it is in different localities called Side-saddle Flower, Huntsman's-cup, and Whip-poor-Will's Shoe. In the Southern Atlantic States, from Virginia

of a long narrow funnel, the "pitcher," closed below and open above. Along one side of the funnel runs a longitudinal projection or wing, and at the orifice, upon the side opposite to the wing, is an appendage which is sometimes called the lid of the pitcher, but it is more correctly a hood. This is an usual form for a leaf to assume, and in comparing it with ordinary leaves the botanist considers these pitchers to represent a leaf with an enormously broad leaf-stalk, which is folded together with the edges united to form the funnel or tube, and the wing before mentioned represents, so to speak, the seam. The blade, which in most leaves forms the largest portion, is here very small, and represented by the appendage or hood at the top of the pitcher. The pitchers, at least the older ones, are usually partly full of water, in which are drowned multitudes of dead insects. In most species, if not in all, the water is not a secretion of the plant, but is collected from rains; but of what service is this or the dead insects to the plant is not quite satisfactorily made out. It is but reasonable to suppose that the plants have need of the in-

sects, else there would not be such an admirable trap for catching them and a supply of water for killing them when caught. Experiments have shown that the Venus Fly-trap actually feeds upon the insects it catches, and does not refuse a diet of beef; and observations upon the Pitcher-plants may show that the insects caught by them contribute to their nourishment. The interior surface of the pitchers of all the species is furnished with sharp hairs pointing downward; near the opening, in some species, at least, there is a sugary exudation which attracts the insects, which, if they go down the tube for water or fall in, find their return much obstructed by the bristly hairs.

To enumerate the southern species of Pitcher-plant, there is the Parrot-beaked *S. Psittacina*, a somewhat smaller species than ours, and, like that, has spreading leaves, the hood to which bends over the opening and has somewhat the appearance of a parrot's bill. The pitcher in this is more nearly covered or closed than in any other species; this, like our *S. purpurea*, has red flowers, as has *S. rubra*, the Red Pitcher-plant. This is one of the rarest, and has erect slender, tubular leaves 10 to 18 inches long and handsomely veined with purple. There are two yellow-flowered species, *S. flava*, commonly called "Trumpets," and the "Spotted Trumpet-leaf," *S. variegata*. The last named has erect leaves about the same length of those of *S. rubra*, and curiously marked with white spots on the back near the top. *S. flava*, or Trumpets, is the largest of all the species, it not being rare to find the trumpet-shaped leaves three feet in length; its flowers, on stems as long as the leaves, are four or five inches across. This is found as far north as Virginia, and in some places grows in great abundance. In traveling through North Carolina we have seen immense quantities growing upon each side of the railroad, forming an interesting and conspicuous object. The most

reduced in size of course, from plants we raised from some roots kindly furnished by a friend at Apalachicola, Fla., near which city it was first discovered by Drummond in 1835. Our native Pitcher-plants, although not quite so wonderful as those of the East Indies, which belong to a different genus, *Nepenthes* (see article on Mr. Such's establishment last month), are all worthy of cultivation. Our common *S. purpurea* is, of course, perfectly hardy, and, like the rest, must have a plenty of water. A handsome clump of it placed in a vase filled with moss makes a charming ornament for a room. The southern species are usually cultivated in hot-houses, but we have found no difficulty in growing them (two of them at least, *S. flava* and *S. Drummondii*) in the open air. The roots were planted in boxes (being less apt to dry out than pots) filled with a mixture of peat, chopped sphagnum moss, and sand. The boxes were placed near the cistern, where they would be sure to be kept quite wet. Late in autumn the boxes were removed to the cellar and looked to now and then to see that the soil did not become very dry.

The Cold Grapery.

BY PETER HENDERSON.

Our climate is particularly well adapted to the cultivation of vines under glass without fire heat, and the wonder is that cold graperies are not in more general use even by people of moderate means than they at present are. We built one for our own use three years ago on the plan shown in the engraving. The dimensions are 50 feet long by 25 wide. It is finished in very good style, and cost but little more than \$1,000. It was planted in June, 1871, and last season we cut upwards of 300 lbs. of fruit from it; next season it will probably yield double that quantity. The "border,"

an inch to a foot, so that thorough and rapid drainage would be sure to be attained. At the extremity of each border a drain was built to carry off the water. The whole bottom was then cemented over so as to prevent the roots getting into the subsoil. This pit was then filled up to the depth of about two feet (four inches being allowed for settling) with a compost which was previously prepared by mixing about three parts of turf top spit from rather a shaly pasture, one part of rotten stable manure, and one part of lime rubbish. The vines were planted in the border outside, the tops being drawn inside through openings left for the purpose. The plants were strong one-year-old vines, and were set about June 1st. By October they had grown to over 20 feet in length. The varieties used were nine-tenths Black Hamburg, with a few Muscats and Frontignacs, which have done exceedingly well.

In November they were cut back to the bottom of the rafter, or about three feet from the ground, and quickly reached the top again the second year, with firm, well-ripened wood. In November they were again pruned back to about three feet above the foot of the rafter, or six feet from the ground. On this shoot was produced the fruit referred to this year (the third from the time of planting). We are just pruning now (the middle of November), and are cutting the shoot back to about four feet from top of the rafter, or about sixteen feet from the ground.

Every December we lay the vines down along the front wall after being pruned, covering them completely up with soil until May, when they are then taken up and tied to the wires, which are $\frac{1}{16}$ galvanized iron, and run across the rafters 15 inches apart and 15 inches from the glass. The training followed is what is called the "spur" system, which is simply to allow one cane or shoot to each rafter (or at three feet apart), and pruning the side shoots or "bearing wood" annually back to one eye. In the summer treatment of the cold grapery the principle must never be lost sight of that to keep the vines in perfect health a temperature of not less than 70° at night with 10° or 15° higher during the day is always necessary. Any rapid variation downward is certain to result in mildew. The floor of the grapery should be kept dashed with water at all times, unless in damp weather, from the time the buds start in May until the fruit begins to ripen in September, except during the period the vines are in flower, when it should be dispensed with until the fruit is set. If the weather is dry copious watering is necessary for the border outside. The summer pruning of the grapery consists simply in pinching off the laterals or side shoots to one eye or bud. Every winter three inches of the best well-rotted stable manure is spread over the border, and over that six inches of leaves or litter; the leaves or litter is raked off in spring, and the manure is forked in, the object being to feed the roots from the top of the border. This same treatment we give our hardy grapes with excellent results.

I am a good deal of a utilitarian, and am very apt to make even my luxuries "pay" when it is practicable to do so; and though we would hardly dream of selling our grapes that have been grown for private use, yet I do not scruple to make the glass that shelters them do

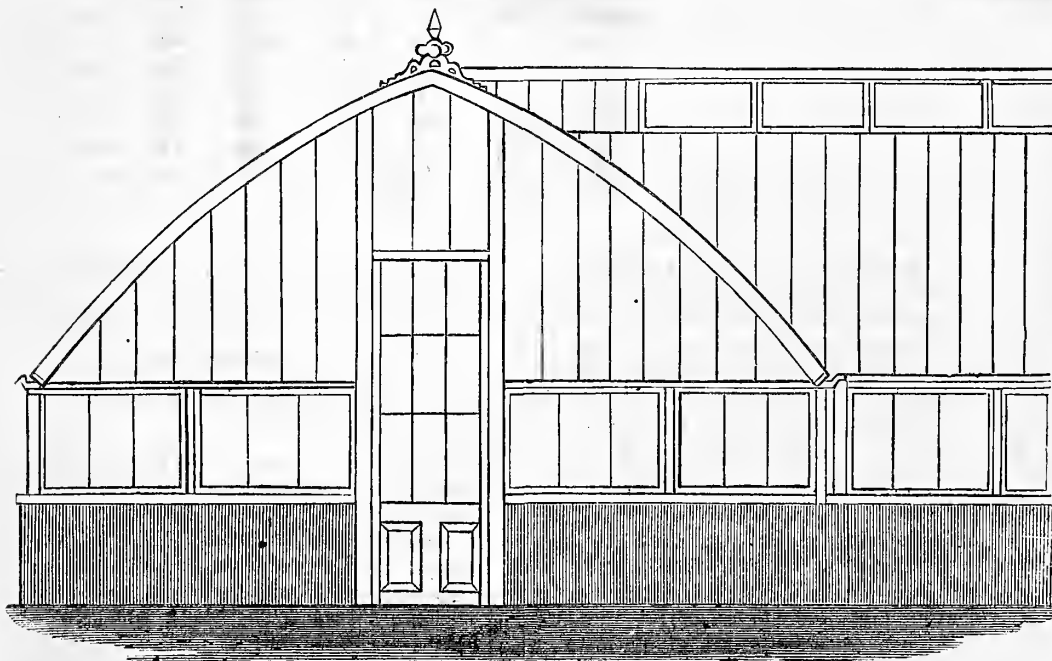

ELEVATION OF GRAPERY, SHOWING END AND PART OF SIDE.

beautiful, so far as the leaves are concerned, and one of the rarest, is Drummond's Pitcher-plant, *Sarracenia Drummondii*. The leaf is about two feet long, funnel-shaped, the rounded blade or hood erect. The upper part of the leaf is white and beautifully netted with conspicuous purple veins. The flower is purple. We give an illustration of this species, much

the proper making of which is of great importance, was begun by excavating the natural soil to the depth of 20 inches for 15 feet in width of the length of the grapery on each side. The inside was left untouched, the borders being entirely outside. The bottom of the excavation was graded from the front of the building to the outside of the borders, with a fall of about

double duty by using it in winter to shelter our half-hardy roses from November to May. Those that do not make rose-growing a business, as I do, can nevertheless profit by my example, and use the cold grapeery for many purposes during the winter months when it is not used for the grape-vines. Besides Roses, all plants of a half-hardy character may be there kept, such as Pomegranates, Grape Myrtles, Pampas Grass, Tritomas, Carnations, etc., care being taken that the pots or tubs in which they are planted are plunged in leaves, tan, or some such substance, so the roots do not get frozen.

ONE HUNDRED DOLLARS FOR A TOMATO.—Peter Henderson & Co. offered last spring to purchasers of seed of their Trophy tomato one hundred dollars for the heaviest and best specimen of fruit exhibited. Over thirty fine specimens were sent in, the best of which was from Jacob Gass, Perrysville, Pa., who says that it was grown without any extra effort, and was selected from a load of forty bushels that he was that day (September 8th) taking to market. It is very doubtful if Mr. Gass received as much money for his whole load as Peter Henderson & Co. paid him for this single tomato, which weighed 23½ ounces, and was perfect in form. An immense specimen was grown at Newark, N. J., weighing three pounds, and measuring 28½ inches in circumference; but it was received in a badly damaged state, and could not be put in competition. This is the largest we have yet heard of, and shows to what an immense size this variety can be grown under particularly favorable conditions.

Notes from the Pines.

My little greenhouse is only 24 feet long by about half that width. If those whose glass measures hundreds of feet in length find as much work in proportion as I do in mine I wonder how they get through with it. But then I have no gardener. I don't think I should care much for plants that some one else took care of. The whole fun of the thing is in seeing one's work grow under his hands. Last spring I raised some

SEEDLING PELARGONIUMS, or Geraniums, as some prefer to call them. The seeds were sown too late for the plants to bloom in the open ground so they were taken up and put in the greenhouse where they are coming on finely. I had a lot of seeds from one of the best known amateurs in France, but these gave me only two plants, while a packet of Bull's (Eng.) seed from Peter Henderson & Co., sown at the same time, germinated freely and have given fine results. There is nothing in floriculture more interesting than raising

FLORISTS' PLANTS FROM SEED.—It will not be easy to define what florists' plants are, but Pelargoniums, Carnations, Auriculas, Primroses, and a host of others are included in the term. These plants have so "broken," as the gardeners say, that we may expect any possible variation from seed. Take the Pelargonium or Geranium, for instance. It has already given a vast number of varieties, and seed from good sorts is likely to give many more. I have plants from seed that ten years ago would have been thought wonderful, but we have so many sorts now that a plant should be remarkably good to merit addition to our named varieties. If the seed be

sown very early in spring the plants can generally be made to flower before frost comes. While recommending the raising of seedling Pelargoniums as a most fascinating amusement, I must give the amateur

ONE CAUTION.—Which is, don't get excited. Those who grow such plants from seed look upon them with a partial eye and are apt to think because a seedling is not bad it must be very superior. They look at it through gold spectacles and think there is money in their favorite plant. Every florist of experience is yearly annoyed by the many seedling Pelargoniums and other plants that are pressed upon his attention. If the amateur's seedling is valuable he may be sure that the florist will catch at it fast enough, but the chances are 99 to 1 it will be not so good as those he already has.

PACKING PLANTS does not seem to be so well understood abroad as with us. I received a parcel from an amateur in England not long ago in which many of the plants were lost by their being packed too damp. Then the labels were—of all things—written upon parchment, and were in many cases nearly dissolved and rendered illegible by the moist heat. Let me say to those who have occasion to send

PLANTS BY EXPRESS OR MAIL that there is more danger from too much moisture than too little. The best packing material is sphagnum or bog moss, and this should be just so damp only as to be elastic to the touch. Plants packed in this, if not too damp, will remain for weeks uninjured; that is if the plants are at rest.

ANOTHER THING IN PACKING is to pack close. If sending by mail, take a piece of strong brown paper; lay the just damp, not wet, moss upon it, put the plants upon the moss and more moss over the plants. Then begin at one end of the paper and roll up *hard*, secure with a string, and then put another paper over for directions. So in packing in boxes, use the moss just damp, and have the box full and crammed down hard, so that there can be no possibility of moving or shaking in transit.

THE ARTICHOKE, or Globe Artichoke as it is sometimes called to distinguish it from the better known Jerusalem Artichoke, is very little cultivated in this country. In this the eatable portion is the base of the scales which surround the large thistle-like flower-head and the bottom of the head. There is but a small portion to each, and though it is to my taste very delicious—something like boiled chestnuts—it will never be very popular among those who like to dine in a hurry, as the separation of the scales to get at their edible portion is very time consuming. Nevertheless as I try to grow every eatable vegetable that the climate will allow, I made a bed of artichokes from plants sent me by a friend in Georgia who had a very large strain. These many times as I have watched the bed during the growth I have said why not use

THE ARTICHOKE AS AN ORNAMENTAL PLANT.—Its stateliness and the silvery color of its beautifully cut leaves adapt it to the purposes of ornament, and I was quite sure that any one of the plants in my bed would have made a sensation had it stood alone in my lawn. I thought I had made a discovery, but—alas! for human hopes—while in a carriage with several horticulturists making our way along the dreary road that leads to the horticultural Mecca of George Such, one of the gentlemen, well-known for his excellent taste in horticulture, broke the silence with, "Did you ever

consider what a fine ornamental plant the Artichoke would make?" In general I like conundrums, but here was my pet discovery gone in a moment. Nevertheless, the Artichoke is as fine as ever. I like to get

ODD THINGS, but when a gentleman in Texas sends five different kinds of bulbs without note or comment it is very puzzling. If he had given the roughest description of the flowers I might have made them out, or if he had said what soil, dry or swampy, they grew in I should have known how to treat them. As it is I have to divide them, and try a part of each as greenhouse bulbs, a part in a cold frame, and others in the open ground.

Among the comparatively new things that I tried last year for the first time are some

ORNAMENTAL PEACHES, several varieties of which were sent last spring by Mr. P. J. Berckmans, of the Fruitland Nurseries, Augusta, Ga., who has a fancy for getting together the unusual forms of the peach. Some are worthy of a place in a collection of ornamental trees.

THE PYRAMIDAL would hardly be taken for a peach-tree if one was not near enough to see the character of the leaves. Its branches all turn upwards, and the general aspect is that of a Lombardy Poplar.

THE PURPLE-LEAVED was rather a disappointment after having my ideas formed upon the colored engraving in the Gardeners' Monthly. Its leaves, to be sure, are purplish red in the spring, but it loses its color as they mature, and the tree is then as green as any other. The young leaves of the second growth are also colored. Of course, the story of this having sprung up from the spot where some general was killed is all "bosh."

THE AUSTRALIAN DWARFS are very promising. These are said to have originated from the *Peen-To*, the flat peach of China. Those two that I have are beautiful bushes; the joints are so close together that the foliage is singularly crowded. Mine have not bloomed yet, but are said to have double crimson flowers and good fruit. It is doubtful if they will succeed in the open air at the north. I put mine in boxes and placed them in the cellar for the winter. They are certainly deserving of the attention of those who grow peaches under glass.

Mr. B. sent me leaves of a curious cut-leaved variety, which he discovered in a bed of seedlings, and which we may hope to know more of.

The Hoya or Wax-Plant.

The kind of house-plants that we best like are those which stay by year after year. Most of our readers no doubt know some house in which the plants—such as an oleander, a laurestinus, an orange or lemon-tree—are as much a part of the household effects as the furniture itself. They have been in the family year after year, placed out-doors or on the "stoop" in summer, and in autumn removed to the living room, where tender care protects them during unusually cold nights. Plants like these have, so to speak, a history; they have grown up with the family, and have in a measure become one of it. We sometimes, though not often, see the Wax-plant treated in this way, and now and then come across a plant that has been in the family for years and years. The Wax-plant is a native of the East Indies, and in its native

country grows upon decayed trees, which it clothes with its fine green foliage. In cultivation it is rated as a stove or hot-house plant, and it is one of the few plants of that class that accommodate themselves to the ungenial at-

improved *arrosoir*. Nothing can be more handy than the common watering-pot; it has two handles, one for carrying and the other for pouring, both made of flat tin, with edges that are very uncomfortable to the hand; then

this handle is so placed that the pot is well balanced in the hand, whether it be full or contain only a quart of water; moreover, the rose is nearly as large as a common saucer, and throws a great number of minute streams.



THE WAX-PLANT.—(*Hoya carnosa*.)

mosphere of the dwelling-room. The engraving gives the leaves and flowers of the Wax-plant rather less than the natural size. The leaves are very thick and fleshy, and remain for a long time. The plant is a rather slow grower in house-culture, and blooms less freely in such conditions than in the hot-house. Its flowers are in clusters, and have such an artificial appearance that the name "Wax-plant" was naturally enough applied to it. They are white or rather flesh-colored, with a pink center. The flower-stalk continues to put out flower clusters, and should not be cut away. It being a climber, the Wax-plant is usually trained to a frame or trellis of some kind; it should have plenty of pot-room, and be well drained. Like all fleshy plants, it requires but little water when it is not in a growing state. There is a variegated form in which the leaves are marked with white, and indeed some of them entirely white. This is a still slower grower than the normal form, and is not to be commended for house-culture. The name of *Hoya* was given to the genus, of which there are some twenty species, in honor of Thomas Hoy, who was gardener to the Duke of Devon half a century ago; the specific name, *carnosa*, refers to the fleshy character of the leaves.

it has a little bit of a rose, which throws a spray over a very small surface, and the operation of watering with one of these clumsy

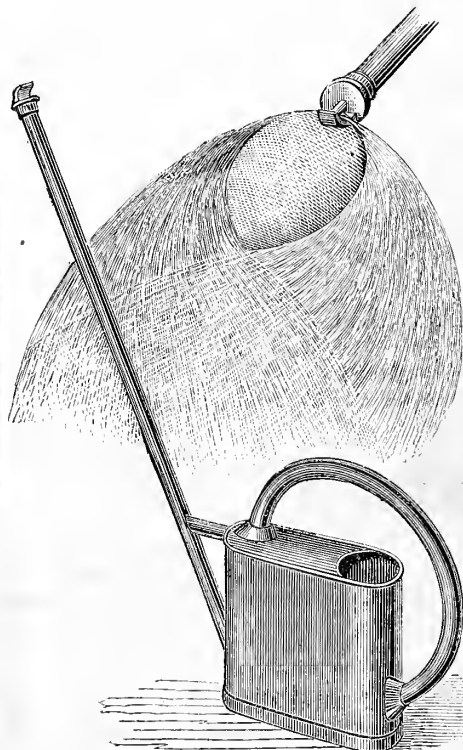

NEW FRENCH WATERING-POT.

A New French Watering-Pot.

In the matter of watering-pots the French man beats both John and John-athan. We doubt if a Yankee or a Britisher ever improved upon the first watering-pot, while scarcely a year passes but the French have some new and

things is a trial to the hands and the patience. A French rose watering-pot has but one handle and that is round and easy to the hand;

When Mr. B. K. Bliss was last in Europe he brought home some samples of a new style of watering-pot in which no rose is used. He placed one of these in our hands for trial, and we were so much pleased with it that we advised him to have a stock of them made for sale. The engraving shows the form of the pot. It will be seen that it has a very long spout and the round and properly placed handle to which we have already alluded. With a handle of this kind the hand can be placed at just the right point for the implement to balance, and there is none of the strain upon the wrist that is demanded by the ordinary form. A column of water of the length of the spout when allowed to flow comes out with no little force. As the stream of water issues from the nozzle it is intercepted by a flange, which is cast in brass of a peculiar shape, with the effect to break the stream into the thinnest possible sheet of water, of a most beautifully curved form. At the upper part of the engraving the form of the discharge of water is shown, as well as that of the flange which produces the effect. It will be seen that the water is dispersed over a broad space, and its force is so far counteracted and it is spread so exceedingly thin that it can be allowed to fall upon small and delicate plants without injury. We are not an advocate of the general watering of gardens unless there is a provision for doing it other than by hand; but hot-beds, plants in pots that are set out for the summer, and newly planted things that must be nursed, all require watering, and we have described an implement which we think will do it more rapidly and satisfactorily than any other that we have seen.

THE HOUSEHOLD.

(For other Household Items, see "Basket" pages.)

About a Laundry.

Washing day is the melancholy day in the household. Everybody is cross and tired, for washing is a disagreeable and laborious work. That it is necessary is no mitigation. No wonder we have frequent communications asking about washing

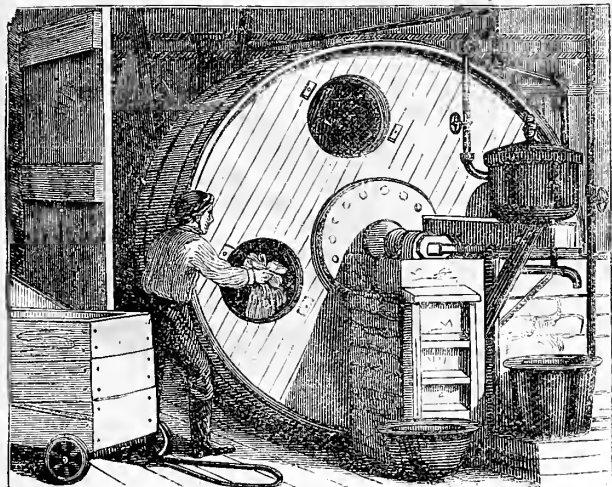

Fig. 1.—WASHING MACHINE.

machines and laundries, and the feasibility of banishing this labor from the household to an establishment where it may be done by machinery for the families of a whole town or village. We have recently visited a laundry in which all the work except the ironing is done by machinery; and because we believe there are many places in country villages and towns where it would be a great convenience to have such a laundry to do the work of a large number of families, we have prepared the accompanying illustrations for the purpose of clearly describing the machines and the methods used.

Figure 1 shows the washing machine. The clothes are put into it through the holes in the side. The holes are then closed up, the hot water and soap are poured in through a pipe, the machinery is started, and in a short time the clothes are sufficiently washed. After rinsing, they are put



Fig. 2.—DRYING MACHINE.

into the rotary drier, figure 2, in which they are freed from water. They are then carried to the drying-room, which is a large apartment heated by ranges of steam-pipes, and there, hung upon lines stretched across the room, they are quickly dried. Those that need starching are put through the machine, figure 3, the superfluous starch is squeezed out, and they are taken to the ironing-room. Shirts which need the bosoms starched and glossed are passed through a machine prepared expressly for this purpose (figure 4) before being

ironed. The irons are heated upon a stove, fig. 5, from which they are taken to the ironing-room adjoining to be used. The machinery here described is suitable for a large laundry; in some smaller establishments lighter machinery is used. The ordinary Doty or similar washing machines of large size are used, which are put in operation by a steam-engine. The wringing or drying, starching, and ironing are performed very much in the same manner in all these laundries. A laundry sufficient to do the work for a hundred families may be furnished for \$1,000, exclusive of the building and a steam-engine of ten-horse power.

Home Topics.

BY FAITH ROCHESTER.

WHAT SHALL BE DONE WITH THE WASHING?—

Many of us could get along quite comfortably without a hired girl if there were no washing and ironing to be done in the house. These two big jobs give us at least two days of hard work—work which alone is quite enough for a strong woman to perform in two days, without the added labor of cooking and dish-washing, and sweeping and bed-making, and *child-nurture*—all of which must be carried along through the washing and ironing days as upon other days. It is often the case that the members of the family could so divide the work between them, as to do it all except the washing, and do it better than any hired servant would. Shall we hire a washerwoman? But we have to pay her a good deal—a large proportion of what a girl's wages would cost. She does nothing but the washing and floor-cleaning, probably, for one day's work, and we have her to wait upon. I have to pay a washerwoman at least a dollar a day, and I can get a hired girl to do all of my family work for two dollars a week. This is, perhaps, lower than the average of wages where I live, but the girls call this an easy place, as they get considerable time here for sitting down or going out. In the summer time I prefer to keep the girl, and then I find more upon my own hands in the way of general "putting to rights," and sewing and care of children, than I can well accomplish and leave margin for getting out of doors and for reading and writing. As cold weather comes, and the city prices of fuel begin to astonish and alarm people in moderate or low circumstances, the case takes a different shape. I see how I can rig up the kitchen warm and snug, and spend the forenoon there, with the children helping (?) me about the chores, doing their little tasks of sewing and knitting and reading, and then getting their frolic out of doors while I prepare our simple dinner—the master of the

house taking his dinner down town. While we eat dinner the other part of the house is getting warm, and the eldest child (aged seven) washes the few dinner dishes, with the little sister's help in wiping them, while I get the sitting-room and its bedroom tidy. Then we take up our afternoon quarters, allowing the kitchen fire to go out, and I notice that this daily change has a good effect upon the spirits—and so, of course, upon the health. What place is there in this arrangement for a hired girl? [I don't like this way of talking. I have to

lay down my pen to listen to the interruption of conscience—something or other about the "golden



Fig. 3.—STARCHING MACHINE.

rule," and about "family selfishness"—all of which I cannot report. I can only acknowledge my personal inability to obey the golden rule in all relations, till sometime in the long "ever and

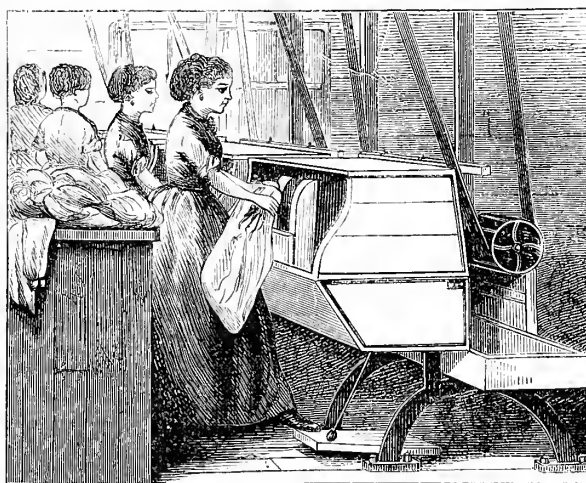

Fig. 4.—BOSOM STARCHER.

ever" when it shall be the standard rule of all mankind.]

I have employed a washerwoman for a few weeks, but it is a very unsatisfactory arrangement. I have to stay in the kitchen myself to do the general housework; so, of course, the children are there too. I do detest the slops and steam, to say



Fig. 5.—STOVE FOR HEATING IRONS.

nothing of the odor that comes from the woman at the tub—one of the tribe of the "great unwashed." The children behave worse than com-

mon, and I get less chance to "oil the machinery," or "wet the clay," or whatever you call the opportune words and "switching off" tricks for keeping squabbles at bay. They get cold feet and hands from the frequent opening of doors, and perhaps from the windows open at the top to let out the steam. If the kitchen must serve as a laundry it should be a pretty bare room, as the steam of the suds is so generally injurious.

I must "put out" the washing, then—to have the flannels all shrunken, the calicos faded, the white clothes begrimed? And then, I do not know of any woman about here (taking in washing) who would keep her room in as wholesome a condition as I should mine. How wet some of these kitchens do get with steam. This added to the compound smell which prevails in such rooms the whole winter long, makes a home for little children about as unwholesome as possible. But the woman wants money to buy shoes and stockings for her children. I can not give her that and pay for the washing beside. She wants to do the washing—mine and other folks—and I pass it along with a heart of pity for her children, and for their mother. She is saved considerable mental suffering by her unenlightened condition. If her baby dies she will only weep over a "mysterious providence."

When can we have good, cheap, public laundries?

A WORD FROM THE WOMAN'S CONGRESS.—While I was agitating the question with which I started these "Topics" this month, an essay upon the subject of "Enlightened Motherhood," read before the Woman's Congress lately in session in New York, came in my way. Much of the "light" attempted to be shed abroad upon this subject is simple darkness, it seems to me. "Ideas are in the air," Emerson says, and I take it as a sign that some of the clouds of crude ideas in our mental skies are blowing over, that an essay on Enlightened Motherhood in the first Woman's Congress should have recognized so well some of the limitations of a mother's power and responsibility.

Mrs. Corbin, who wrote the paper on Enlightened Motherhood to which I refer, had been studying a pamphlet sent out to the mothers of Philadelphia by a medical society of that city, "On the Care of Young Children during Hot Weather." Mothers were told, in that, to have their cooking done "in a shed, or in the yard, or in the garret," but there was a plain suggestion that a kitchen in the bottom of the house must impair the purity of the atmosphere of the rooms above. Mothers were also told to keep their children out of the rooms where cooking and washing were being done.

If this latter caution is important in hot weather when all the windows and doors may stand open, it seems equally so in winter when the steam and odors are so much more confined.

Almost every day children come into our house who smell so badly of the odors of the kitchens where they live that I can hardly bear to go near them. I have not tried to count the smells, but I distinctly perceive tobacco smoke, burnt grease, and over-burnt, over-boiled, bitter coffee.

Mrs. Corbin tells how she inquired of her wise physician what she could possibly do to save the life of her babe who was slowly dying. He answered: "The best that you can do, the best that any mother can do with a nursing baby as delicately organized as this one, is, as much as possible, at all times and under all circumstances to keep a quiet mind. Be placid, equable, unmoved. Your baby draws her life from your life now. It must be sweet, serene, unshaken by storms, or she can not thrive upon it."

Mrs. Corbin says: "But what advice is this to give to a housekeeper, beset with the nameless and numberless sources of discord and inharmony which characterize the reign of the "black beast" and Bridget. With a kitchen stove, and an ordinary cook, or rather the ordinary succession of cooks, each one worse than the last, the cases are rare and exceptional when a woman can ever be sure of a year and a half of such quietude of

mind as is absolutely necessary to the proper bearing and rearing of a child. It is, therefore, after mature deliberation, and with a solemn sense of my own responsibility to God and man, that I stand here and charge upon the kitchen stove a very large percentage of the mortality that desolates our homes. Banish cooking and laundry work from the house, with all their concomitants of foul odors, unnecessary heat, and an atmosphere periodically surcharged with vapor, and the salubrity of the premises would be increased fifty per cent. With cookery and laundry work, Bridget also would fold her tent like the Arabs, and as silently steal away."

Several years ago Mrs. Stowe, in the pages of the Atlantic Monthly, prophesied and prayed for the establishment of public laundries and public cooking houses. It will probably be some time yet before we get them, even in our cities, and we must possess our souls in patience and do the best we can. Let us learn all that we can about the laws of health, about ventilation and wholesome cookery; and let us be more careful to prevent the escape of steam into our kitchens, where our children have to live as long as their mother is confined there. What if we should abolish dough-nuts and griddle cakes and other fried food? Couldn't "papa" stand that? Ah! He must be "enlightened" too!

"THE BLACK BEAST."—It is blacker than there is necessity for, it seems to me. Mr. R. had a leisure day at home lately, and after doing a number of "dickering jobs," he said to me:

"If you will tell me where to find the blacking, I'll black the cook-stove. It is just cool enough now."

I thanked him, but said I didn't want it blacked. I knew it was quite brown, but I was content to have it so. He looked surprised and I explained.

It has been several years since a blacked kitchen stove has seemed clean to me. I hardly dared to entertain such a thought, till I found that some of the very neatest housekeepers thought so too, and practiced accordingly. They wash their stoves daily, and the surface of the stove is then clean. A blacked stove blackens everything that rubs against it, and the children's stockings often suffer from its contamination. I have never been able to polish a stove without a deal of trouble to prevent soiling the carpet or walls adjacent; and I always feel as though my own body and clothing have been unnecessarily defiled, even when I wear gloves. To keep a stove black requires daily attention, and it is one of the unnecessary cares with which I do not choose to encumber myself.

My auditor looked his approval, and remarked: "They say that greasy dish-water is best for washing a stove."

"I can not bear to use it," I said, "the smell of it upon the hot stove is so disagreeable. I prefer to keep a cloth for that especial purpose, and to use clean water. The greasy water gives a blacker surface to the iron, but that does not pay me for the bad odor it gives out."

"I think you are right," said Mr. Rochester. "Besides polished stoves give out less heat than those with rougher brown surfaces."

It is not necessary to put the hands into the water with which the stove is washed. Make a small mop or swab with a wooden handle, and rinse this out and hang it to dry each time when you have done with it.

CARE OF THE HANDS.—Is there any particular virtue in rough, red hands? It is disgraceful to shirk necessary labor, but soft, white hands are a comfortable thing for a wife and mother, or any other woman to possess. Try a few drops of ammonia in the basin of water with which you wash your hands after the day's housework is done. It has a softening and cleansing effect. Powdered borax is also excellent. Glycerine is the thing to use upon chapped hands and the cracks at the finger ends.

A WORD FARTHER ABOUT STOVE HEARTHES.—It occurs to me that I overlooked one strong point in favor of the high hearths. It is not often, I

think, that your low hearth offers equal facilities with a high one for broiling. Certainly no way of cooking a steak is quite equal to genuine broiling. I have tried the way of cooking it in a hot ungreased spider a good deal, but broiling is better, though usually more troublesome.

GRIDIRONS OR BROILERS, AND STEAKS.—The gridirons that go with our stoves usually have grooved iron bars. It is a trouble to keep these clean. Wire broilers are more easily managed. One that shuts the steak in so that it can be turned, gridiron and all, is very convenient.

A steak should be turned several times, at very short intervals. It should lie as near as possible to the hot coals. The under side sears almost instantly. Turn it before the juice has a chance to gather upon the upper surface, and sear that side also. Frequent turning keeps the juices in the steak, but if you perceive them upon the meat when you go to turn it, hold it over the hot meat platter while you turn it. The double wire gridiron makes this an easy matter. This, also, is the easiest gridiron that I know of for snatching from the coals when a blaze flashes up. Salt thrown upon the blaze puts it out. Flames under the steak are apt to give it a bad, burnt flavor. To avoid them cut away and leave out the big chunks of suet that sometimes come with the steak.

Do not season the steak till nearly or quite done. Put it at once between hot platters with its seasoning, and after a few moments you will find it all covered with juice or gravy.

I have used a patent broiler upon the top of the stove over a hot blaze, but I prefer the coals. When broiling at the top of the stove over a wood fire look out for your draughts. If there is a "top draught" in the front of the stove, this is the time to open it. Have the dampers turned so as to draw the smoke up chimney as fast as possible, never using the oven at the same time.

What Shall we have for Breakfast?

The above question was proposed in the November number, and the answers have been coming in at a most unexpected rate. Indeed, so numerous are the lists that the committee to whom they were referred have been unable to make the decision in time for it to be published in the Household pages, but it will be given among the "Basket Items," as that portion of the paper goes to press some days later than this.

Puddings and Pancakes.

BY MRS. H. S. P.

PLUM PUDDING.—Two eggs; six crackers; three pints of sweet milk; a piece of butter the size of an egg; one cup of raisins; a little salt and nutmeg.

BAKED INDIAN PUDDING.—Four eggs; one quart of sweet milk; five large tea-spoonfuls of Indian-meal; nutmeg and sugar to the taste. Boil the milk and scald the Indian-meal in it, then let it cool before adding the eggs. Bake three-quarters of an hour. Eat with butter or sweet sauce.

PANCAKES.—One egg; two spoonfuls of sugar; one cup of sweet milk; one tea-spoonful of soda; two tea-spoonfuls of cream-of-tartar; three cups of flour.

QUICK PUDDING.—One egg; one cup of sugar; one table-spoonful of melted butter; one cup of sweet milk; half a tea-spoonful of soda; three cups of flour. Bake half an hour or more. Eat with sweet sauce.

SAGO PUDDING.—Two large spoons of sago boiled in one quart of milk; the peel of a lemon; little nutmeg; when cool add four eggs; little salt. Bake about one hour and a half. Eat with sugar and cream.

DOUGHNUTS.—One egg; one cup of sugar; two cups of sour milk; one spoonful of cream if the milk is not very rich; one tea-spoonful of soda; little salt; nutmeg; flour enough to roll.

BOYS & GIRLS' COLUMNS.

About Horse-Shoes.

Who made the first horse-shoe? We do not know, and doubt if any one does. We can get a pretty good idea of what the first one was like from the kind now in use in the far East, where everything that belongs to farming is at the present day very much as it was in the time of "Moses and the prophets." The corn is trodden out by oxen just as it was in Scripture times, and if Adam ever did any plowing he probably used the crooked stick that at the present day turns the soil of the Holy Land. A gentleman attached to the Oriental Topographical Expedition—which is engaged in surveying the Holy Land—recently brought us an Eastern horse-shoe. It is so unlike the shoes used upon our horses that we thought the boys and girls would like to see an engraving, which we give in figure 1. The shoe seems to have been beaten out of a piece of iron, and beaten so thin as to make a

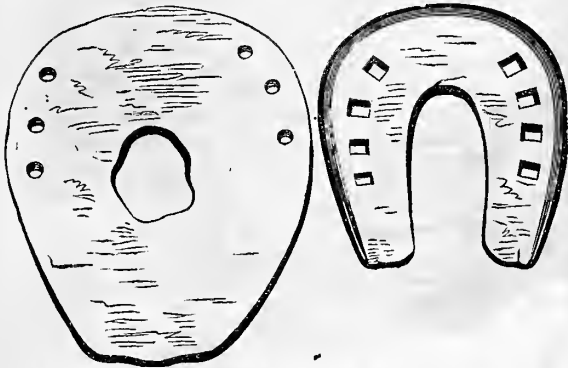

Fig. 1.—ORIENTAL. Fig. 2.—MEXICAN HORSE-SHOE.

hole in the middle, which is left of an irregular shape. The shoe at the edges is not thicker than ordinary pasteboard. Of course, a horse with so much flat iron on his feet would not be very sure-footed, so the nails by which the shoe is fastened to the hoof are made with very large heads. The Spaniards are not much in advance of the Orientals in their farm implements, and in those parts of America settled by the Spaniards we find that no improvement has taken place for centuries. We give alongside of the Egyptian shoe one that we brought from Mexico several years ago (figure 2). This is rather ahead of the Egyptian affair, but looks very odd in comparison with those we use. The Mexicans do not, as a general thing, shoe their horses and mules, but in a rocky country they are obliged to, and this is the kind of shoe they use. The nails by means of which the shoe is attached have heads which project from the surface of the shoe about half an inch.

The Doctor's Talks.

ABOUT A PIECE OF LIMESTONE.

Last month I asked you to put some of your lime with a plenty of water in a bottle, cork it up, and let it stand. The liquid will look perfectly clear and quite like pure water, and the lime will apparently have all settled at the bottom. We found that limestone before it was burned did not dissolve in water; now does it behave any differently after being burned? There looks to be as much lime at the bottom of the bottle as there was at first; but it will not do to trust to appearance. So to find out whether the water is just the same as when it was put with the lime we must ask it questions. The eye tells us nothing; how is it with the taste? Pour a little of the liquid out of the bottle and taste. It does not taste very pleasantly, but it will not hurt you to just taste it. This is evidently not pure water, and we infer that it has taken up (dissolved) some of the lime. To question this liquid still further you can get a few bits of the outer leaf of a red cabbage; put them in a cup and pour boiling water over them, and when cold pour this cabbage tea into a glass. It will be of a bluish or violet color. Add a little of the water which came from your lime—lime-water we will call it—and see what happens. Your cabbage liquid turns at once of a beautiful green. You might further prove that the water had dissolved some lime by pouring some of it into a clean saucer and placing this on the cooler part of a stove, where it will gradually dry up or evaporate. When the water is all gone, and the saucer quite dry, you will find a film or scum of something upon the inside of the saucer. This film is so very thin that you will conclude that the water has dissolved but very little lime, and you will be right. Although the water has dissolved all the lime that it possibly can, the quantity is only about nine grains in a pint of water. Or to put it in another way, one part of lime

requires over 700 parts of water to dissolve it. Two ordinary barrels of water are not able to dissolve one pound of lime. When water or any other liquid has dissolved all of a solid that it can the solution is said to be saturated. We can have a saturated solution of lime by using, as we see, a very little. A pint of water is saturated with about nine grains of lime, but it would take five or six ounces of common salt to so saturate a pint of water that it could dissolve no more; and if we dissolve sugar a pint of water will need about twice its weight of sugar before it is saturated. Although water at the ordinary temperature dissolves so little lime, boiling water dissolves still less. When you hear "lime-water" spoken of you will know that it means this clear solution of lime in water. When lime is stirred up with water it makes a milky mixture, such as is used in white-washing, which is often called "cream of lime" or "milk of lime. This is, however, only a mixture, and not a solution, for if it is allowed to stand all the lime, except the little that water can dissolve, will settle to the bottom of the vessel that holds it. Now, there are two more experiments that I wish you to try with your lime-water. Dissolve a small bit of soap in water, a piece as big as a bean in half a teacupful of water. When the soap is dissolved add some lime-water. You will see that a curdy matter will form which will not dissolve in water. Our hard soaps are made of soda and fat; they are soda soaps, and these dissolve in water. When you add lime-water to a soap of this kind the lime, so to speak, takes the fat away from the soda and forms a lime soap which is not soluble. You see now why some waters are called "hard." They contain lime in some form, which they dissolve while in the earth, and when we undertake to wash our hands in them with ordinary soap there happens just what did when you poured lime-water into a solution of soap—a lime-soap forms, which sticking to the hands makes them feel very unpleasantly. The second

experiment is to put into a tumbler or wine-glass some of your lime-water, and then with a straw, pipet, or other such tube breathe into the lime-water—that is to take a full breath, and then let the air from your lungs pass through the straw or other tube in bubbles through the lime-water. Before your breath has passed for many seconds into the lime-water you will see that it is clouded; it will soon become so milky that you can not see through it. If you set it aside a white powder will fall to the bottom of the glass. You will wonder what this means. What can there be in your breath that should so disturb and cloud the clear lime-water? Before we answer this let us go back a bit. In November I told you that one way to test lime-stone was to powder it and pour vinegar over it, when small bubbles would rise. Again, last month you were told that when limestone was strongly heated to make lime of it it lost almost half its weight. What did it lose in the shape of bubbles when vinegar was put to it, and what did it lose when heated? The loss in both cases was the same—carbonic acid. I can not stop to tell you more about carbonic acid now than that it is an invisible gas, in which a flame can not burn, and in which an animal can not live. So poisonous is it, that when air is mixed with only a moderate share of this gas illness or even death may be produced. When coal or wood is burned this gas is formed and mixes with the air. When limestone is heated or "burned," as it is called, to make lime, large quantities of this gas are given off, and it forms in other ways; so a very little, about 1/2000 of its bulk, is always present in the air. Though in large quantities it is injurious to animals it is needed by plants. They can not grow without it. They are constantly taking it up from the air. Animals are, on the other hand, constantly sending it out of their lungs; it is the way in which much of our food is used up, this forming of carbonic acid. When you breathed into the lime-water the carbonic acid of your breath united with the lime to form carbonate of lime, which is just what the limestone from which it was made was. But we must now leave the limestone—but not I trust without many of you having found something to think of.

THE DOCTOR.

Something about Gunpowder.

Boys have a great fancy for gunpowder, and their interest in the subject is especially lively early in the month of July. The father of one boy says he likes to gratify his boys upon the Fourth of July, but he finds gunpowder rather expensive, and he wishes to know if we can not tell him the proportions of niter (saltpeter), charcoal, and sulphur, so that he can make his own powder. As the answer to this question will interest boys in general, we put it here. The proportions of the ingredients of gunpowder are about 16 parts each of charcoal and sulphur to 100 parts of niter. If these are powdered

very fine and mixed, they would have all that gunpowder contains, but the firing of it, would produce no bang at all but only a rather slow-burning fizz. You see it requires something besides the sulphur, charcoal, and niter—the value of the powder depends upon the making—so we must advise this gentleman and boys in general to give up the idea of making their own powder, as, aside from the danger of the matter, they can not succeed without going to great expense. But perhaps you will like to know how it is done at the powder factories? Well, the ingredients are reduced to the finest possible powder by being put into revolving drums with several hundred pounds of balls or bullets, which, as the drum turns, fall and roll and grind the stuff as fine as dust. Then enough water is added to make a paste. This paste is put between cloths and put under a powerful press, and comes out in cakes. These cakes, when dried, are broken up by stamping-mills, and the grains of different sizes separated by means of sieves. All the dust powder is sifted out, and the different sizes of powder separated according to fineness. Then the best kinds are put into a drum which revolves, and the grains rub against one another and give that handsome polish seen in the best rifle powder. Ordinary cannon powder is coarse compared with that used for rifles and shot-guns; and that made for the enormous cannon now in our forts and monitors—"baby-walkers," the sailors call them—is so coarse that you might take it for lumps of coal, though you might find out the difference if you undertook to kindle a fire with it. The powder is made coarse for these large guns, so as to burn comparatively slowly. If it went off as "quick as a flash," the gun would probably "go off" too, instead of the ball.

A Game for a Winter's Evening.

Perhaps it is not exactly a game, but it might be easily made into one. I don't know what to call it either, unless it be a "Journey by the Fireside," or it may be the "Home Encyclopedia." The idea is this: Some one selects an object, any common one whatever, and questions the others. Take, for illustration, the first thing before me—my lamp. See what a lot of questions may come out of this. What is the lamp made of? What is brass? What is zinc? Where does it come from? In what shape is it found? What color? Does it melt easily or not? What is it used for besides to make brass? So the same series or longer of questions about the copper. The base of the lamp has lead run into it to make it heavy, and a whole lot more can be learned about that. Then the chimney and shade are glass, and probably but very few can tell much about so common a thing as that. The wick—that is, of course, cotton. What is cotton? what part of the plant? where is it grown, and all about it? why is the wick made hollow, in the form of a cylinder? Then the oil—there is quite a story about that. Here is a single article in the room that would keep a lot of bright boys and girls profitably at work a whole evening. Such a looking-up of dictionaries and other books before some of the questions could be properly answered! and no doubt some of the older people would find themselves at their "wit's ends" to answer all the questions that could be put. I hope some of the boys and girls will try this, for they will find out in the first place how little they really know about the articles they handle and use every day, and in the second place they will find that these silent common things, like some silent common people, have a history if they can be only made to tell it. At least so thinks your OLD UNCLE.

Aunt Sue's Puzzle-Box.

ANAGRAMS.

- | | |
|-------------------|-----------------------|
| 1. Nay, quit it. | 6. Men cram beer. |
| 2. Seal soup. | 7. Hence no rice. |
| 3. Burn slate. | 8. Scald no one. |
| 4. A red mile. | 9. Tote in a prouter. |
| 5. Tin cod faces. | 10. Suerer assent. |

GUS AND JOE.

CROSS-WORDS.

- My first is in bird but not in owl.
My next is in duck but not in fowl.
My third is in fat but not in lard.
My fourth is in soft but not in hard.
My fifth is in meat but not in bone.
My sixth is in slate but not in stone.
My seventh is in bowl but not in plate.
My whole is a city in New York State.
CLAUDE.
- My first is in sermon but not in text.
My next is in worried but not in vexed.
My third is in new but not in old.
My fourth is in heat but not in cold.
My fifth is in sturdy but not in bold.
My whole we all strive for, I am told.
N. TRAVIS.



[COPYRIGHT SECURED.]

A DUBIOUS PROSPECT.—Drawn and Engraved for the American Agriculturist.

DIAMOND PUZZLE.

(Which reads horizontally, perpendicularly, round the corners, and all sorts of ways.)

1. What you will always see in a car.
2. A fish.
3. To appertain.
4. A well-known Southerner.
5. The fifth of a quart.

The center word may be completed in twelve different directions.

GUSTAVUS M.

PL.

Verey no'se talfus ear ton witrent no shi heardfoe.

NUMERICAL ENIGMA.

I am composed of twelve letters.
 My 1, 2, 3 is part of the hody.
 My 12, 5, 3 is often eaten by infants.
 My 3, 5, 11, 8 is what naughty children do.
 My 10, 7, 6 is a household article.
 My 4, 9, 8 is a boy's nickname.
 My whole is an animal.

W. EUGENE W.

CONCEALED TREES AND FLOWERS.

1. Look out for that cannibal, Sam; he is dangerous.
2. Sambc lives in a little hut near the swamp.
3. That ape on your fence is eating the peaches.
4. I left my satchel, muff, and boa in the carriage.
5. K. M. Franklin, dentist, spares no pains when pulling teeth.
6. Washington's birthday is a holiday.

C. H. M.

DOUBLE ACROSTIC.

The initials name what we must all have in this world; the finals name what we should strive for in the next.

1. Civil.
2. What the king is.
3. What the champion docs to all others.
4. What the farmer does with his seed.
5. A mermaid.

WM. L. E., Jr.

SQUARE-WORD.

Square the word "BLIND."

H. H. CLARK.

ANSWERS TO PUZZLES IN THE OCTOBER NUMBER.

NUMERICAL ENIGMA.—The Declaration of Independence.

CROSS-WORD.—Martin.

BLANKS.—1. Dane, deign. 2. Read, red. 3. Not, knot. 4. Scene, seen. 5. Bear, bare.

PL.—Mildness governs better than anger.

ANAGRAMS.—1. Unalloyed. 2. Sacerdotal. 3. Enjoyment. 4. Adversaries. 5. Asthmatic. 6. Fundamental. 7. Ligatures. 8. Phenomena. 9. Shagreened. 10. Legislation.

ALPHABETICAL ARITHMETIC.—

34792058(265) (Key: Our pet lamb.)

CONCEALED RIVERS.—1. Negro. 2. Neckar. 3. Po. 4. Mayn. 5. Congo. 6. Red. 7. Lena. 8. Boyne. 9. Ohio. 10. Neuse. 11. Indus.

CHARADE.—Warrant.

SQUARE WORDS.—

1. HOME	2. FARM
OVAL	ALOE
MAIL	ROSE
ELLS	MEET

NOTICES TO CORRESPONDENTS.

F. H. N.—Your rebus was not of a convivial type. Thanks, nevertheless.

NELLIE H. L.—Certainly, dear, you "may send" your "alphabetical arithmetic." It is not a great deal more trouble for me to revise than to construct.

EMMA L. D. thinks that "the few hundred rivers published in the November *Agriculturist* will be a great assistance" to her "when hunting in future for 'concealed rivers.'"

Thanks for letters, puzzles, etc., to O. A. Gage, Charley S., M. L. A., F. D. M., S. R. G., and Frank Powers.

A Dubious Prospect.

The artist calls his picture a dubious prospect, and it apparently is one for poor Jack. The barn is evidently none too good, and all through the night Jack has heard the storm, and when daylight came he had little difficulty in pushing open the carelessly-closed window and taking a look about him. He now sees what has happened during the night, and looks upon the drifts that the wind, which made him so uncomfortable, has heaped up against the barn. He perhaps wonders if the boy whose business it is to furnish his breakfast will make his way through snow-drifts as high as the barn window. If said boy is like some boys we have known, old Jack's chances for an early breakfast are indeed "dubious." Then again, if the boy is like some others that we have known, and are glad to know, his first thought as he looked from his window at the wintry prospect was for the old horse, who is quite dependent upon him for comfort; and if he is the right kind of a boy he will think that the horse on such a morning as this needs his feed earlier than on a warm one, and if he should give old Jack something a little extra this snowy morning we should think all the better of him for it. We don't think much of a boy who does not get attached to a good, faithful family servant such as old Jack no doubt is. One can make a very good guess at the character of a boy or girl, and judge what kind of a man or woman they will make, by the way they care for the animals dependent upon them. We hope that the boy will not only give the anxious-looking horse his hay and oats, but an extra feed of sixpenny nails. "Feed a horse on six-penny nails! I never heard of such a thing."—Well, probably you never did. But you know that food keeps the horse warm, and when it is very cold he has to eat more to keep comfortable than in warm weather. Well, if the boy uses the nails to fasten up loose boards, and thus keep out the cold winds and make his stable warmer, it is very much the same as if he gave him extra food. That is what we mean by hoping for Jack an extra feed of nails.

The Vienna Exhibition.

AUSTRIAN COURT HONOR TO AN AMERICAN CONTRIBUTOR.

TELEGRAMS TO THE NEW YORK HERALD.

VIENNA, Nov. 1, 1873.

THE Emperor of Austria has conferred the "Imperial Order of Francis Joseph" upon Hon. Nathaniel Wheeler, President of the celebrated Wheeler & Wilson Sewing Machine Company of New York.

MORE DISTINGUISHED HONORS.

BALTIMORE, Md., Oct. 31.

THE Maryland Institute has awarded Wheeler & Wilson the gold medal for the new No. 6 sewing machine. Other sewing machines received nothing.

Seedsmen and Florists!

Your attention is called to the advertisement of Geo. P. ROWELL & Co. on page 37. If you desire to advertise effectually and cheaply write at once to ROWELL & Co., 41 Park Row, New York. You will find this firm prompt, energetic, and reliable.



Breech-Loading Shot-Guns of all the celebrated makers. Sturtevant's Patent Brass shot shell.

Shooting Tackle of every description. Send for Descriptive Catalogue.

SCHUYLER, HARTLEY & GRAHAM, 19 Maiden Lane, New York.

GEO. A. PRINCE & CO.

ORGANS & MELODEONS.

The Oldest, Largest, and Most Perfect Manufactory in the United States.

53,000

Now in use.

No other Musical Instrument ever obtained the same popularity.

Send for Price-Lists. Address

BUFFALO, N. Y.



"The Best Article in the Market."

ASBESTOS ROOFING

H. W. JOHNS, 87 Malden Lane, N. Y. Patentee and Sole Manufacturer. Established 1838.

Mothers,

Why do you neglect to buy

SILVER-TIPPED

Shoes for your children? They never wear through at the toe.

The only reliable covering for the Feet is

Cable Screw Wire

BOOTS AND SHOES.

\$75 PER WEEK

made by our agents throughout the country selling our celebrated La Perle Rubber Goods. Indispensable articles for Ladies and Children's wear. LA PERLE RUBBER CO., 90 Chambers Street, New York.

MONEY MADE RAPIDLY with Stencil and Key Check Outfits. Catalogues and full particulars free. S. M. Spencer, 117 Hanover st., Boston, Mass.

AGENTS LOOK!—\$12 a day made selling Scissors Sharpener and other wares. Sample 25 cts. Catalogue free. T. J. HASTINGS & CO., Worcester, Mass.

SEEDS

Our handsomely Illustrated Catalogue for 1874 is now ready. Purchasers of Seeds will do well to consult it before making up their orders. Our Flower and Vegetable Seeds, being grown with the greatest care and attention, from the very best of stocks, recommend themselves to all who desire a safe and profitable return for their investment. All we ask for them is a trial; they will tell their own story. Catalogues free to regular patrons; to others on receipt of Ten Cents.

KERN, STEBER & CO., SEED GROWERS,

211 Market St., St. Louis, Mo.

SEEDS

OUR BEAUTIFULLY ILLUSTRATED CATALOGUES for 1874, of

SEEDS AND PLANTS

Numbering 175 PAGES, and containing 2 fine large colored plates, are now ready. To our patrons they will be mailed as usual free; to all others, on receipt of 25c, which we return in Seeds or Plants, with first order. All purchasers of our Books, either for Gardening for Profit, or Practical Floriculture Price \$1.50 each (prepaid by mail,) have their names entered on our lists, and will receive above Catalogues annually, free of charge.

Peter Henderson & Co.
Seedsmen, 35 Cortlandt Street, New York.

PLANTS

SEEDS,

Western grown. Catalogue free. Special Price-list for MARKET GARDENERS,

English or German. Send name to

GEO. S. HASKELL & CO., Rockford, Ill.

WHAT--WHERE

---WHEN---HOW

To Plant Farm, Garden, and Flower Seeds; what they will cost, and all other desirable information in our

HAND-BOOK for 1874, Containing a Beautifully Colored Chromo.

Sent to all applicants, post-paid, on receipt of 10 cents, by

JAMES FLEMING, Seedsmen, 67 Nassau St., New York.

PATRONS OF HUSBANDRY.

No Middle Men. Free Price List.

THE JONES SCALE WORKS, Binghamton, N. Y.

The Little Corporal.

AN ILLUSTRATED MAGAZINE FOR BOYS AND GIRLS.

THE LITTLE CORPORAL, by its attractive stories, poems, and beautiful pictures, has become a welcome visitor in many thousands of homes, furnishing instruction and entertainment to the Boys and Girls, and older people who have young hearts. The leading serial for 1874 will be written by EMILY HUNTINGTON MILLER, whose stories are always wide awake and entertaining. **2 Months Free!!** All new subscribers for 1874 will receive the Nov. and Dec. numbers of this year FREE! Also, by first mail a copy of our new chromo—"Writing to Papa," or a pair of our beautiful chromos—"Mother's Morning Glory," and "Little Runaway," mounted ready for framing. **Terms \$1.50 a year.** No charge for chromo and extra numbers. Send for specimen numbers and raise a club.

JOHN E. MILLER, Publisher, Chicago, Ill.

No More Loose Bolts and Nuts.

THE CELEBRATED "CUMMING" LOCK-NUT, Patented June 16, 1868.

No More Rattling CARRIAGES and WAGONS. No More Dropping Down of SHAFTS.

No More Lost Bolts from REAPERS and MOWERS.

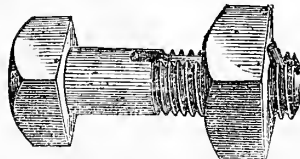

No More Flying Teeth from THRESHERS.

No More Bills for Repairs Continually.

SEND FOR PRICE-LIST AND CIRCULARS TO

THE LOCK-NUT AND BOLT CO. OF N. Y., No. 61 Broadway, New York.

Licenses granted to Manufacturers of Agricultural Machines, Carriages, etc.

1874.

Now is the Time to Subscribe

TO

HARPER'S PERIODICALS.

Harper's Magazine.

The Magazine has done good and not evil all the days of its life.—*Brooklyn Eagle.*

Harper's Weekly.

The ablest and most powerful illustrated periodical in this country.—*Louisville Courier-Journal.*

Harper's Bazar.

There never was any paper published that so delighted the heart of woman.—*Providence Journal.*

TERMS for 1874.

HARPER'S MAGAZINE, One Year.....\$4 00
HARPER'S WEEKLY, One Year..... 4 00
HARPER'S BAZAR, One Year..... 4 00

One copy of either will be sent for one year, POSTAGE PREPAID, to any Subscriber in the United States, on receipt of Four Dollars by the Publishers.

HARPER'S MAGAZINE, HARPER'S WEEKLY, and HARPER'S BAZAR, for one year, \$10 00; or any two for \$7 00; postage payable by the Subscriber at the office where received.

An Extra Copy of either the MAGAZINE, WEEKLY, or BAZAR will be supplied gratis for every Club of FIVE SUBSCRIBERS at \$1 00 each, in one remittance; or, Six Copies for \$20 00, without extra copy; postage payable by the Subscribers at the offices where received.

TO FARMERS & PLANTERS.



DOUBLE REFINED POUDERETTE for sale in lots to suit customers. This article is sold for half the price of other fertilizers, and is cheaper for Cotton, Corn, Tobacco, and Vegetables than any other in the market. Price, delivered on board in New York City, \$25 per ton. Ask attention to the following testimonials:

CHARLES A. MESSENGER, Providence Co., R. I., writes: "The Double-refined Poudreite I bought of you has given satisfactory returns, and I consider it the best of anything I can use for an early crop." THOMAS W. LATHAM, Providence Co., R. I., writes: "I would rather have your Double-refined Poudreite than any phosphate I ever used. Where I used it on Potatoes it was far ahead of any other manure."

L. H. SHELDON, Sup't of the New Jersey State Reform School, writes: "We have used Poudreite for several years upon our farm crops, and for the money invested we have found nothing that has done us so much service."

S. J. KELLY, Burlington Co., N. J., writes: "I used Double-refined Poudreite on Rutabaga Turnips alongside of Peruvian Guano and Hen Manure. Where the Poudreite was applied the increase was thirty per cent over the others."

WILLIAM H. CADY, Ocean Co., N. J., writes: "I used Poudreite on Corn, Sweet and round Potatoes, Onions, and Lima Beans. It brought forward my crops two weeks earlier. I think if the best manure I ever used, giving better results than Peruvian Guano, at much less cost."

VAN ANTWERP AND VAN BUREN, Montgomery Co., N. Y., writes: "Poudreite has been used in this locality for ten years past, mostly on Corn, and those who have used it say they have from 1/2 to 3/4 more Corn by using the Poudreite."

W. F. GERKIN, of Essex Co., N. Y., writes: "I have used the Double-refined Poudreite for the last five years, and I consider it the cheapest fertilizer I can buy—giving the best results for the cost."

MILTON STRONG, Suffolk Co., N. Y., writes: "I gave Poudreite a thorough trial this year, using it upon Corn, Potatoes, Lima Beans, Tomatoes, and Vines, and I have never raised better crops. My Corn will yield 100 bushels of ears per acre, and my garden was the surprise and admiration of all who saw it."

HENRY T. HORTON, Cheshire Co., N. H., writes: "I find, from experiments made last year, the Double-refined Poudreite is the cheapest fertilizer to use on Tobacco. I put it beside Peruvian Guano with equal cost of both, and the Tobacco was 30 per cent better where I used Poudreite."

W. H. REMINGTON, Hartford Co., Ct., writes: "I have used Poudreite on Corn, Potatoes, and Tobacco. There was but one piece of Corn in the place equal to mine, and that had 30 loads of manure per acre and mine none. The Tobacco started as soon as set and grew luxuriant."

WM. S. POMEROY, of Hartford Co., Ct., writes: "I have used the Double-refined Poudreite for several years on Tobacco, and I think it one of the best fertilizers made for this crop."

A Pamphlet giving full directions, etc., sent free on application to JAMES T. FOSTER, 66 Cortlandt Street, New York.

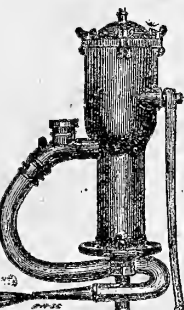

THE PEOPLE'S Force & Suction PUMPS.

For the house and out of doors, and for wells from 10 to 120 ft. deep. Awarded Medal of American Institute, Nov. 15, 1873, for "best force pumps" of all exhibited.

For list of Agents see advertisement in Am. Agriculturist for November, 1873, page 431, and send for circular and price-list.

W. S. BLUNT, 77 Beekman St., New York.

GALE'S HAY, STRAW, & STALK CUTTER. \$3 to \$10 for hand-power. For hand or horse-power, \$16, \$18, \$22, 75,000 now in use.

GALE'S Turnip, Carrot, & Potato Cutter. \$12. Turned by a boy, cuts a bushel a minute. Machines need not be paid for till tried on your farm and found satisfactory. Good chance for agents. Circulars free. WARREN GALE, Chicopee Falls, Mass.

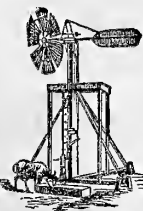

Halladay's Improved Wind-Mill.

PERFECTLY Self-Regulating. The Best, Cheapest, most Durable and Popular Mill made. Manufactured under the immediate supervision of Inventor 18 years. Two million dollars' worth new in use. Send for Catalogue.

U. S. WIND ENGINE & PUMP CO. BATAVIA, ILL.

FIRST Premiums awarded by Amer. Inst., 1870. MICROSCOPES. Illustrated Price-List sent free on application.

MAGIC LANTERNS. Catalogue, priced and illustrated, sent free.

T. H. McALLISTER, Optician, 49 Nassau-st., N. Y.



REMINGTON'S Sporting, Hunting, and Target Breech-Loading Rifles & Shot Guns.

Also, Revolving, Repeating, Deringer, and Vest Pocket PISTOLS and RIFLE CANES. Double-Barrel Breech-Loading Gun IS NOW READY.

The best ever offered, containing all the most desirable features of the best imported, together with some valuable improvements peculiar only to this gun. Top Snap action, half-cocked, breech opened and shells extracted by one motion.

E. REMINGTON & SONS, 281 and 283 Broadway, N. Y.

OR, ARMORY, ILION, N. Y.

CUT THIS OUT AND SEND FOR ILLUSTRATED PRICE LIST.

WHEELER'S PATENT ANTI-SNOWBALL PAD,



For the Prevention of Baling and Slipping, and infallible against picking up stones. Made of the best rubber, easily adjusted or removed; does not cover the frog; can not injure the hoof, as no nails are used; will fit any foot without removing the shoe; and with ordinary care will last several seasons. For sale at all first-class Saddlery and Hardware Stores. Price \$1.50 per pair. NORTON & DICKINSON MANUFACTURING COMPANY, 49 Murray St., New York, Agents. CHARLES L. WHEELER, Patentee, No. 3 Custom House St., Boston, Mass.

Murray St., New York, Agents. CHARLES L. WHEELER, Patentee, No. 3 Custom House St., Boston, Mass.

Horse-Shoe Sharpener.

LITTLE'S PATENT will sharpen the calks of the shoes on the hoofs of one horse in ten minutes. Owner of one horse will save cost of machine (which can be used twenty years) in one sharpening season. Agents wanted. Send for circular. LITTLE'S HORSE-SHOE SHARPENER CO., 60 Vesey St., New York.

REID'S WIRE CURRY-COMB

Beats all others. Because 1st. It carries a horse quicker and more thoroughly. 2d. It does not scratch or injure the horse's skin. 3d. It never wears out. 4th. It does not cut the hair off the brush. 5th. It is especially adapted to thin-skinned or restive horses. Sent by mail for 30c. For further particulars and wholesale price address A. H. REID & BRO., Brandywine Manor, P. O., Chester Co., Pa.



For full particulars, address ENGLE, KELLER & CO., Lancaster, Pa.

MARTIN'S IMPROVED Brick Machine.

Adopted and used by the leading Brick manufacturers. Made and sold by the AMES MFG CO., Chicopee, Mass.



BUILDING FELT.

This water-proof material, resembling fine leather, is for outside work (no tar substances used) and inside, instead of plaster. Felt carpets, etc. Send two 3-cent stamps for circular and samples. C. J. FAY, Camden, N. J.

Kentucky Blue Grass Farms.

Kentucky Lands for sale. Improved and undeveloped. In size and locations to suit, at \$1.50 to \$10 per acre. Address WILLIAM S. RAND, Vanceburg, Lewis Co., Ky.

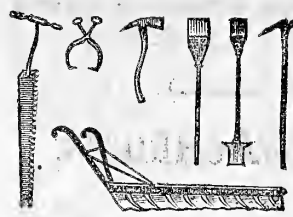

ICE-TOOLS! AT REDUCED PRICES. Send for Descriptive Circulars. DECATUR & COXE Agricultural Warehouse and Seed Store, 197 Water St., New York.

STAR EARTH CLOSET CO.—LATEST and BEST COMMODOES at such reduced prices that none can afford to do without them. Send for circular to 22 Dey Street, New York.



Improved Foot Lathes.

Small Engine Lathes, Small Gear Cutters, Hand Planers for Metal, Ball Turning Machines, Slide Rests, Foot Scroll Saws. The very best. Selling everywhere. Catalogues free. N. H. BALDWIN, Laconia, N. H. Just the articles for Artisans or Amateurs.

AMERICAN AGRICULTURIST.



PATENT DEPARTMENT.

IMPORTANT TO INVENTORS. American Agriculturist PATENT DEPARTMENT

In compliance with the request of numerous inventors, we have organized a

PATENT DEPARTMENT

in connection with this office for the transaction of all business connected with

Securing Patents

in the United States and foreign countries.

Reliability

which has been maintained by the AMERICAN AGRICULTURIST for more than thirty years will be carefully guarded in this as in other departments.

All Inventors

desirous of procuring patents at moderate cost are invited to forward (express prepaid) a model of their invention, with a brief description of its working. The model should not exceed one cubic foot in dimension. Upon receipt of model an opinion as to patentability will be given free of charge.

Preliminary Examination

at the Patent Office, to determine patentability, will be promptly made for a fee of \$5.

Litigation of Patents.

The services of the best counsel have been secured to prosecute or protect before the U. S. Courts and the Patent Office the claims of those intrusting their business to this agency.

Specifications, drawings, engravings, models, and all other appliances furnished at moderate prices.

In all dealings with this Department inventors may depend upon promptness, fidelity to their interests, and the best services which can be rendered by thorough experts.

For full particulars, address

AMERICAN AGRICULTURIST PATENT DEPARTMENT, ORANGE JUDD COMPANY, 245 Broadway, New York.

AMERICAN AGRICULTURIST. ORANGE JUDD COMPANY, Publishers, 245 Broadway, N. Y. ANNUAL SUBSCRIPTION TERMS (always in advance): \$1.50 each for less than four copies: Four to nine copies, \$1.25 each; Ten to nineteen copies, \$1.20 each; Twenty copies and upward, \$1 each. Papers are addressed to each name. Either English or German Edition, at these prices. HEARTH AND HOME: \$3 a year for less than four. Four to nine copies, \$2.75 each; 10 or more copies, \$2.50 each.

Hearth and Home (weekly) with American Agriculturist sent to one address for \$4 a year.

Try JANUARY. There is no Better Month than this, in all the Year, for Making up Clubs and Securing the Valuable Articles offered in our Premium List.

The Publishers of American Agriculturist and HEARTH AND HOME take pleasure in presenting their new general Premium List for 1874. The Premiums which they have offered in past years have engaged the attention of a very large number of persons of all ages and both sexes. Many thousands have secured Premiums, and very many of these, who at first had small hopes of success, have been themselves astonished at the ease with which they have raised large clubs and secured valuable Premiums.

Here is pleasant and profitable work for all.

- Boys and Girls, Young Men and Maidens, Middle-aged Men and Women, Farmers, Mechanics, Merchants, Professional Men, Anybody, Anywhere

who wishes to do good and make money, can do both by going to work as here invited by the publishers of these two most valuable journals, American Agriculturist and HEARTH AND HOME. You need only to show specimens of the papers, promise the beautiful Chromos, which are now ready for delivery, according to the publishers' offer, and forward your subscriptions.

There is no danger of failure in the enterprise if you go into it with spirit. You may succeed in

raising a club much larger than you had at first calculated upon; and even should you secure fewer subscribers than at first hoped for, the Premiums are so many and so various that you could not fail to be suited with some good thing on the list.

Persons of all classes have engaged successfully in the work, and very many have materially increased their income, and that too without encroaching upon their ordinary working hours and with but little trouble to themselves. The articles offered as Premiums are worth the regular price which is set against them. They are new and good. They have almost universally pleased and satisfied the recipient. You can obtain one or more of them.

TRY IT. The American Agriculturist is everywhere known and approved. HEARTH AND HOME issued every week, with the Best Original Stories, contributions on Live Topics, a capital Household Department, and a most interesting Department for Children and Youth, should be in every home in America. The papers are entirely different. Taken together, they supply more good reading than can be found in fifty books costing one Dollar each.

Premium Clubs can be made up of subscribers to either paper, or partly of one and partly of the other, as noted over the Table. We call especial attention to the last column of figures, showing the small number of names required where both papers are taken, at the reduced price of \$4 a year.

You, Reader, can get a Premium. TRY IT.

Explanatory Notes. N. B.

Read and carefully

Note the following items: (a) All subscribers sent by one person count, though from one or a dozen different Post-offices. But... (b) Tell us with each name or list of names sent, that it is for a premium... (c) Send the names as fast as obtained, that the subscribers may begin to receive the paper at once. You can have any time, from now until July 1st, to fill up your list... (d) Send the exact money with each list of names, so that there may be no confusion of money accounts... (e) Old and new subscribers all count in premium clubs, but a portion, at least, should be new names; it is partly to get these that we offer premiums to canvassers... (f) Specimen Numbers, etc., will be supplied free as needed by canvassers, but they should be used carefully and economically, and where they will tell... (g) Remit money in Checks on New York Banks or Bankers, payable to order of Orange Judd Company, or send Post-office Money Orders. If neither of these is obtainable, Register Money Letters, affixing stamps both for the postage and registry; put in the money and seal the letter in the presence of the Post-master, and take his receipt for it. Money sent in any of the above ways is at our risk; otherwise it is not.

[In the following table is given the price of each article, and the number of subscribers required to get it free, at the regular rates, \$1.50 a year for American Agriculturist, and \$3.00 a year for Hearth and Home; also at the club rates of \$1 and \$2.50; also at the rates of \$4 a year for both papers together.] Descriptions of Premiums on next page.

N. B.—In all Premium Clubs for either paper, TWO copies of American Agriculturist (English or German) at \$1.50 each, and ONE copy of Hearth and Home at \$3.00, will count exactly the same. So also two copies of American Agriculturist at \$1 each, and one copy of Hearth and Home at \$2.50, will count exactly the same. In this way Premium Clubs can be made up from the 2d and 4th columns, or from the 3d and 5th, or wholly from the 6th column.

Table of Premiums and Terms. Columns include: No., Names of Premium Articles, Price of Premiums, American Agriculturist (Number of Subscribers required), Hearth and Home (Number of Subscribers required), and Both Papers Together (Number of Subscribers required). Rows list various items like Moore's Floral Set, Gold Pen, Paragon Pen, etc.

Every Premium article is new and of the very best manufacture. No charge is made for packing or boxing any article in our Premium List. The Premiums, Nos. 2 to 8, 27 to 33, 55 to 78, and 81 to 93, inclusive, will each be delivered FREE of all charges, by mail or express (at the Post-office or express office nearest the recipient) to any place in the United States or Territories.—The other articles cost the recipient only the freight after leaving the manufactory of each, by any conveyance desired. See Description of Premiums on Next Page.

Full Descriptions

of our Premiums are given in a previous number, and will be mailed free to applicants. We have room in this paper only for the following Descriptive Notes:

No. 1.—Moore's Floral Set.—This is a beautiful Premium—a complete set of Ladies' or Children's Garden Tools for the cultivation of flowers, consisting of a Floral Hoe, Spade, Fork, and Rake. They are made of the best steel and iron, with finely polished hard-wood handles, light, durable, and highly finished, and each set inclosed in a box. They will be found very convenient in the garden and greenhouse, and are pleasing toys for the little folks. Made by the Moore Manufacturing Company, Kensington, Ct.

Nos. 2, 3, 4.—Gold Pens; with ever-pointed Pencils, in extension, coin-silver cases.—Premium No. 2 contains the best No. 4 Gold Pen; and No. 3 the best No. 6 Gold Pen, which is the same style, but larger. No. 4 contains No. 7 Gold Pen, in Gold-tipped Ebony Holder. Each pen will be sent in a neat leather case by mail, post-paid. These pens are made by Geo. F. Hawkes, No. 66 Nassau St., and have obtained an excellent reputation. We have known the maker and his goods for many years, and can recommend them.

No. 5.—Ladies' Fine Gold Pen, in Rubber Case, Gold Mounted, with Screw Extension, and Gold Ever-pointed Pencil. A beautiful present for a lady teacher or friend. Same maker as No. 2.

Nos. 6, 7.—Paragon Patent Revolving Pencil.—This is a beautiful Pocket Pencil, which is extended or closed by pulling or pressing the head. They are made with great care, and every Pencil warranted to work perfectly. They are gold-plated, and will last for years. We offer two patterns, one for ladies, with ring for chain, at \$1.50 each, and one of heavier and firmer plate, at \$3.00. Same maker as No. 2.

No. 8.—Payson's Indelible Ink, and Briggs's Marking-Pen Combination.—Payson's Indelible Ink is too well known to need further commendation. It is almost indispensable in the family. Briggs's Marking-Pen has been before the public for fifteen years, and is justly celebrated for all kinds of marking, and particularly for writing upon coarse fabrics. The Pen and Ink are put up in a neat case, being thus portable, always ready for use, and protected from loss or injury by evaporation or breakage.

No. 9.—Cake Basket.—A new pattern, oval-shaped, nicely chased—a very taking, useful, and beautiful table ornament. This, with other articles that follow, is made by the Lucius Hart Manufacturing Co., of Nos. 4 and 6 Burling Slip, New York City, and is warranted by them to be of the best triple plate. Mr. Hart, "the veteran Sunday-school man," was engaged in the same place and business for nearly a quarter of a century. We have known him and his work for many years, and have taken pleasure in commending and guaranteeing its value to be as represented. We believe the Company which bears his name is fully sustaining his reputation. The amount of silver upon plated ware depends wholly upon the will and integrity of the manufacturer. We could give nearly as good-looking plated ware for less than half the money.

No. 12.—One Dozen Teaspoons.—

No. 13.—One Dozen Table-Spoons.—These are "figured tips." Olive-leaf Pattern, all of the same metal, plating, etc., and from the same makers as No. 9. They are far cheaper than anything we have found at half the price, and are well worth working for.

No. 14.—One Dozen Table-Forks.

—The same description and remarks apply to these as to No. 13. We select as premiums only such articles as we can warrant in quality and price. All these articles come from the Lucius Hart Manufacturing Co.

No. 15.—Child's Cup.—A beautiful gift for the little one-year-old. It is made by the Lucius Hart Manufacturing Co. Triple-plated on the outside and gilded on the inside. It never breaks, and will last for many years—indeed, be a life-keepsake.

No. 17.—Child's Carriage, or Perambulator.—An elegant carriage, handsomely finished, upholstered with reds, has full plate tuned joints, handle tips, side lights, dash rail, panel body, and carpet on the bottom. These carriages are from the well-known manufacturer C. W. F. Dare, 47 Cortlandt St., New York.

No. 19.—Doll's Cottage Chamber Set.—A most attractive gift for a little girl. Eight pieces of furniture prettily painted: Bedstead (size 11½ X 18 inches), bureau, table, commode, towel-rack, two chairs, one rocking-chair. From C. W. F. Dare, 47 Cortlandt St., New York.

No. 20.—Crandall's Improved Building Blocks furnish a most attractive amusement for children. Churches, Dwellings, Barns, Mills, Fences, Furniture, etc., in almost endless variety, can be built with them, and the structures remain so firm as to be carried about. For developing the ingenuity and taste of children they are unequalled. The Blocks are put up in neat boxes, accompanied by a large illustrated sheet giving various designs of buildings, etc. This is one of the most successful toys ever invented.

No. 21.—Crandall's Masquerade Blocks.—These are put up in boxes, the blocks in each of which will make, by various combinations, 300 different pictures in brilliant colors. They are not injured by washing, and afford endless amusement for children. They are beautiful gifts for the little ones.

No. 22.—Knives and Forks.—These have ebony and metal handles, manufactured by a patent process which unites them so firmly to the blades that they never work loose, and are rendered hot water-proof. The knife blades are silver-plated. Made in the best style by the Woods Cutlery Co., 55 Chambers St., New York. For this Premium we will give either the Table, Medium, or Dessert size, as may be specified by the recipient; six knives and six forks, or twelve knives without forks.

Nos. 23, 24, 25.—American Table Cutlery.—We are glad to be able to offer really good articles of American manufacture, such as are competing successfully with the best foreign make. Messrs. Patterson Bros., 27 Park Row, who supply us with these articles, are also importers of English goods. They recommend these Knives, manufactured by the Meriden Cutlery Co., as equal to any Cutlery in the market, and their recommendation is a guarantee wherever they are known. We offer two kinds of Knives, and three sizes of each kind. No. 23 have Rubber Handles, which are actually boiling-water proof, so that, if they were accidentally to remain in it for several minutes, or even hours, they would not be injured. The Blades are of the best steel, and warranted. Dessert size, with Forks, sold at \$15.00. For 24 subscribers at \$1.50, or 80 at \$1, we will give either the medium size or the table size, sold at \$16.00. No. 24 have Ivory Handles, are selected with great care, have Steel Blades, and are beautiful goods. Dessert size, with Forks, sold at \$20.00. For 33 subscribers, at \$1.50, or 110 at \$1, we will send the medium size, sold at \$22.00. For 35 at \$1.50, or 116 at \$1, we will send the Table size, sold at \$23.00. The Forks, which accompany these Premiums, Nos. 23 and 24, are made of genuine Albata, and warranted double-plated with coin-silver. These Forks are furnished to us by Messrs. Patterson Bros.... The Carving-Knife and Fork are made by The Meriden Cutlery Co., with the best Ivory, balanced Handles.

Nos. 27, 28, 29, 30.—Pocket Knives.

—HERE'S FOR THE BOYS AND GIRLS!—These Premiums are among the most pleasing and useful that we have ever offered. Every boy, and girl too, wants a pocket knife. We give them an opportunity to obtain a most valuable one for merely a little effort. These knives are furnished by the Meriden Cutlery Co., 49 Chambers St., New York, whose work is equal to any done in this country or Europe. No. 27 is a neat, substantial Knife, with three blades and buck-horn handle. No. 28 is a still finer article, with four blades and pearl handle. No. 29 is an elegant Knife, with five blades and shell handle. No. 30 is a Lady's Pocket Knife, a beautiful article, with four blades and shell handle.

No. 31.—Mutton in Parvo Pocket Knife.—Boys, Read this. It is a most attractive as well as useful Premium, from the Meriden Cutlery Co., 49 Chambers St., New York.

It comprises, in one knife-handle, a large and a small blade, a screw-driver, a saw, a strong hook, a nutcracker, a brad-awl, a gimlet, a corkscrew, a pointer, a slim punch, tweezers, and, in addition to this, it can be used for various other purposes which will at once suggest themselves to any smart boy or man. It is a pocketful of tools weighing but two ounces. The knives will be sent anywhere in our country, post-paid.

No. 33.—Extra Early Vermont Potato.—This remarkable potato is a seedling raised in 1867 from a seed-ball of the well-known Jackson White. It is supposed to have been fertilized from the Garnet Chili, as it resembles many seedlings of that variety. For five years the "Vermont" potatoes have been grown side by side with the Early Rose, both under the same treatment, and have proved seven to ten days earlier than that favorite sort; they are more productive, fully equal to the Early Rose if not superior in quality, flesh very white, dry, and starchy, excellent keepers, and in every way a most promising variety. We have made arrangements with Messrs. E. K. Bliss & Sons, 23 Park Place, New York, to supply us with the genuine article, to go by mail, post-paid, to any part

of the country. They should go out before freezing weather, but when too late for this we will keep them until warm enough to mail them in the spring. This Premium can only remain open while the supply lasts.

No. 40.—Doty's Improved Clothes Washer, with the Metropolitan Balance Weight. Over seventy-five thousand families in the United States are using the Doty Washing Machine, and we believe the improved machine has no superior. The "help" use it and like it. Send for descriptive circulars to R. C. Browning, 32 Cortlandt St., New York, or to Metropolitan Washing Machine Co., Middlefield, Ct. It goes cheaply by freight or Ex.

No. 45.—A Good Watch.—The Watches made by the American Watch Co., Waltham, Mass., have peculiarities of excellence which place them above all foreign rivalry. The substitution of machinery for hand labor has been followed not only by greater simplicity, but by a precision in detail, and accuracy and uniformity in their time-keeping qualities, which by the old method of manufacture are unattainable. A smoothness and certainty of movement are secured which proceed from the perfect adaptation of every piece to its place. The extent of the Waltham establishment, the combination of skilled labor with machinery perfect and ample, enable them to offer watches at lower rates than any other manufacturers. Their annual manufacture is said to be double that of all other makers in this country combined, and much larger than the entire manufacture of England. The mechanical improvements and valuable inventions of the last fifteen years, whether home or foreign in their origin, have been brought to their aid, and the presence of nearly 800,000 Waltham Watches in the pockets of the people is the best proof of the public approval. We offer a Silver watch, jeweled, with chronometer balance, warranted by this Company as made of the best materials in the best manner, and in pure coin-silver "hunting" case; weight 3 oz. This watch we offer as one of our Premiums, with the fullest confidence. Upon the movement of each of these watches will be engraved, "AMERICAN AGRICULTURIST. MADE BY THE AMERICAN WATCH CO., WALTHAM, MASS."

No. 46.—Ladies' Fine Gold Watch.

—This elegant Premium will delight our friends who may receive it. Our arrangement with the American Watch Co. (see No. 45 above) includes these beautiful gold watches. They are full-jeweled, in 18-carat "hunting" cases, warranted to be made of the best materials, and possessing every requisite for a reliable Time-keeper. Upon the movement of each Premium Watch will be engraved "AM. AGRICULTURIST. MADE BY THE AM. WATCH CO., WALTHAM, MASS."

No. 48.—Double-Barrel Gun; or

FOWLING PIECE.—These guns are the genuine London "Twist" barrel, Patent Breech, Bar Lock, ebony ramrod, and in all respects desirable. Their caliber and length of barrel vary, and may be ordered to suit the kind of shooting to be done. They are furnished for this Premium by Messrs. Cooper, Harris & Hodgkins, 177 Broadway, well-known as one of the most reliable and best houses in their line of business, and they highly recommend this particular gun, and guarantee it in every respect. It is from one of the oldest and most favorably known English manufacturers. The price is not put on in fancy carving and plating for show, but in the gun itself. This Premium includes Gun, Powder-Flask, Shot-Pouch, and Wad-Cutter.

No. 49.—Remington's Sporting

Breech-Loading Rifle.—The Rifle offered as this Premium has a 30-inch steel barrel, and can be of any weight from 8 to 13 lbs., and of any caliber from $\frac{27}{100}$ to $\frac{60}{100}$, as may be desired. Ammunition is extra, and at prices varying in accordance with the caliber. These rifles are manufactured by the noted firm of E. Remington & Sons, Nos. 281 and 283 Broadway, New York, whose reputation is world-wide, and who stand in the front rank of manufacturers of fire-arms.

Nos. 81 to 92.—Good Libraries.—

In these premiums, we offer a choice of Books for the Farm, Garden, and Household. The person entitled to any one of the premiums 81 to 92 may select any books desired from the list of our books published monthly in the American Agriculturist, to the amount of the premiums, and the books will be forwarded, Post or Express paid. Let the farmers of a neighborhood unite their efforts, and through these premiums get an agricultural library for general use. See Table List of Books in advertising columns.

No. 93.—General Book Premium.

—Any one sending 25 or more names, may select books from our list to the amount of 10 cents for each subscriber sent at \$1; or 30 cents for each name sent at \$1.20; or 60 cents for each name at \$1.50. This offer is only for clubs of 25 or more. The books will be sent by mail or express, prepaid through, by us. See List as in No. 81.

Grape-vines run Wild.—A subscriber in Plymouth, Iowa, asks what he shall do with vines three or four years old that "have always grown as they pleased."—This is a difficult conundrum to answer. Could we see the vines we could decide at once, but it is difficult to prescribe without seeing the patient. When the leaves are off the buds will be plainly seen. Let our Iowa friend remember that each of these buds will produce a shoot next spring, upon which the fruit will be borne. If he cuts all the canes made this year back to two buds each, he will probably leave twice as many as are needed. No invariable rules can be given for pruning a vine. One should understand the way in which a vine grows, and adapt his knowledge to the case in hand.

Mushroom.—"J. C. G." The plant in question can not be, from your rough outline, the edible mushroom. It is more probably the Morel. We can not decide without seeing a specimen. The attempts at cultivating the Morel have not been very successful.

Smoking Pork.—Hams and pork are almost always over-smoked. When saturated with smoke the meat is rendered indigestible and unpalatable, and we notice that there is a general complaint now making in regard especially to the excessive smoking of Cincinnati pork. The common practice of allowing meat to hang in the smoke-house during the whole winter, and to smoke it for a few hours almost every day for several weeks, is destructive to its proper flavor and wholesomeness. For bacon, two days' smoking with corn-cobs or hickory brush is sufficient; for hams, four days' is quite enough, and sufficient flavor will have penetrated in that time to the center of the meat to make it palatable to the most smoke-loving taste.

Value of Brewers' Grains.—"Hawthorne." Brewers' grains fed to cows help the production of milk, but we would not advise any feed when the production of butter is in view but the very sweetest and most perfect meal. Sour feed will inevitably make itself known in the flavor of the butter.

Weevil in Barns.—"J. S. R.," East Moriches, L. I. When a barn is infested with weevil it is a difficult matter to get rid of them. If the granary only is infested they may be killed by washing the floors and walls with strong, boiling hot soft-soap suds. The granary should then be washed over with lime-wash in which carbolic acid is dissolved. The weevil may be kept out by having wire-gauze over the windows and by making the walls of the building very tight and close. On the approach of cold weather the weevils leave the wheat and hide in the crevices of the granary; then is a good time to destroy them. No grain should be stored until the granary has been thoroughly swept and cleaned. All the dirt and weevil swept out should be burned.

Injection Syringe.—"J. W. T.," North Haven, Ct. An injection may be given to a horse by means of an ox or pig's bladder, in the neck of which a wooden pipe is inserted. The pipe may be made of a piece of elder from which the pith has been forced out. It should be reduced in thickness, made very smooth by sand-paper, and should be well greased or oiled when used. The injection of a pint of linseed oil or a quart of salt and water is needed to remove the worms which infest the rectum or lower intestine.

The Chufa or Earth Almond.—"E. L. S.," Phelps Co., Mo. The chufa or earth almond (*Cyperus esculentus*) is a plant of the same genus as the Nut-grass which is found such a pest in Southern fields. It was introduced from Spain about 20 years ago; and the fact that during that time it has never made any sufficiently favorable impression upon those who have experimented with it to induce them to continue its growth is not a recommendation to it. Its only use has been as food for swine, and for this purpose it has been favorably spoken of by some of the Southern agriculturists.

Spreading Lime in Winter.—"J. C. W.," Manasses, Va. Lime may be spread upon the snow or frozen ground during winter as well as late in the fall. It should, however, be finely slacked and evenly spread. This plan will answer upon wheat or rye or upon meadows which may require liming. As a general thing it has been found desirable to apply lime in this way upon clover fields which are to be broken up the next season for corn or wheat.

Pleuro-Pneumonia.—"F. R. W.," Waterbury, Conn. The first symptoms of pleuro-pneumonia in a cow or ox are such as are only to be noticed by a person who has observed the habits of healthy animals. They are a slight increase of the temperature of the body, difficult breathing, with drumming or whir-

ring noise in the bronchial tubes. A cough frequently occurs, the appetite fails, and the animal becomes thin. Then the milk falls off, and shivering fits commence the second stage, after which the animal rapidly becomes worse. The best treatment has been found to be careful nursing, warmth, and hanging sacks saturated with carbolic acid in solution before the animals' heads, so that the vapor can be breathed; warm gruel and mash, and one to two drams of elixir of vitriol in a gallon of water.

Potato Rot.—"C. C.," Westbrook, N. J. It is generally accepted that potato rot is due to a species of fungus, though some doubt whether the fungus is the cause or the result of the rot. The more interesting question to the farmer is how he shall avoid the disease. It has been found that drainage of moist land, avoiding the use of raw barn-yard manure, or, in fact, any fermenting substance, and the growing of potatoes upon dry gravelly loams, or light dry soils, with the help of superphosphate of lime and wood ashes as manures, tend to the growth of healthy potatoes. Excessive moisture, and the presence of decomposing vegetable matter, cause abundant growths of various species of molds and other fungi, and are, therefore, greatly provocative of rot in the potato. The best plan is to avoid the causes, and mitigate, if not prevent the trouble.

Manufacture of Fertilizers.—"B. S.," Allen Co., Ind. Guano is not a manufactured article, but a natural product, the origin of which is a disputed point. Superphosphate of lime is simply bones or mineral phosphate of lime, treated with sulphuric acid in such a way as to separate a portion of the lime from the phosphoric acid, leaving the phosphoric acid in excess, hence the term *super-phosphate*. The extra phosphoric acid is thus soluble in water, and can be readily appropriated by plants. Artificial fertilizers are now so largely manufactured, and there is so much competition in the business, that they may be purchased much cheaper and better than they can be made by the farmer.

Plaster upon Wheat.—"P. W.," Buncombe Co., N. C. It is better to apply plaster upon any crop in the spring than in the fall. The best time is as soon as growth has fairly commenced. About 100 to 200 pounds per acre is a heavy dressing.

Cats.—"H. C. B.," Ellsworth, Me., writes us that he stops the depredations of cats upon his poultry houses by setting a fox-trap in the entrance hole and covering it with chaff, by which plan he has trapped 16 in a short time. To this we would remark that this is an unnecessary barbarity. There is not the slightest need to have cats or any other nightly depredators in the poultry houses. The entrances should be closed every night and opened every morning. This would not only keep the fowls safely during the night, but prevent much disease and loss from their early wanderings amongst wet grass and weeds. Cats should be well fed, as being necessary farm animals, and not be allowed to exist in a half-starved condition, which is often a satisfactory excuse for many of their so-called thefts.

The Florida Settler.—We have received a pamphlet, entitled "The Florida Settler and Immigrant's Guide," a manual of information concerning the soil, climate, and productions of that State, prepared by the commissioner of lands and immigration, whose office is at Tallahassee, Fla. Now that attention is turned towards the mild climate, orange groves and gardens of Florida, this pamphlet is opportune. It will be sent by the commissioner on receipt of request with stamps to cover postage.

Poisonous Pastures.—Not long since we noticed a statement of the death of forty-four out of a herd of over seventy cattle upon an English pasture, in consequence of their feeding upon poisonous plants, chiefly or wholly an umbelliferous plant, known as the Drop-wort (*Oenanthe crocata*). Similar losses of stock have occurred recently in Australian pastures, from certain species having been eaten during periods of scarcity of wholesome fodder. During the past few years many cattle have died in various localities in the West, from various disorders, to which many fanciful names have been given. Murrain, fevers of all sorts, red water, black water, and in loss for another name these deaths have been attributed to "new" and "unknown diseases." The symptoms of the cases of poisoning above referred to, and those of the deaths which have been reported to us or have been described by other journals, are strikingly similar. Staggering gait and profuse frothing at the mouth, convulsive twitchings of the flank, blood-shot eyes, bloody urine, congested membranes, and often offensive diarrhoea, a lateral curvature of the neck, and in many cases violent frenzy equally mark the whole, and point unmistakably to poison of some kind.

It is an important question if a large portion of the deaths amongst our native cattle in the West are not due to the presence of poisonous plants in the pastures. Generally late in the summer, when the grasses have become dry and withered, the Western pastures are covered with a mixed herbage, of which a large portion is innutritious and indigestible, and may be poisonous; of this the cattle are impelled by hunger to partake. In the cases of poisoning referred to, the supposition was originally that some sudden disease had stricken the animals, but on examination of the contents of the stomachs the fatal plants were found, and the true cause of death ascertained. A knowledge of the nature of poisonous plants would be very valuable to stock owners, as would also such habits of observation as would lead to the easy detection of the causes of deaths. Doubtless murrains of various kinds, Texan fever, and other obscure disorders, owe their existence to causes which a careful observer might discover.

Cost of a Crop of Corn.—"J. B. S.," New York. The cost of raising an acre of corn, where all the labor is hired and a man and team costs six dollars per day, will be more than the value of the crop. For instance, the following estimate will show what result may be expected: One day plowing, a quarter day harrowing, a quarter day marking out, and one day in all cultivating, equal to two and a half days' team work, \$15. The planting, enting, and hnsking will occupy five days of a man's labor, equal to \$10; total, without counting seed and fertilizer, \$25. The crop may yield 25 bushels shelled corn under these peculiar circumstances; but if 40 are realized an even account will result, leaving the fodder to cover some expenses not enumerated.

Renting Dairy Farms.—"W. R. R.," Buchanan, Mich.—We are not prepared to say from actual knowledge what proportion of the final produce the renter of a cheese dairy farm should receive for his labor. In renting a grain farm on the half share of all the produce, the tenant has more labor to perform than he would have on a dairy farm, and the owner would have a larger investment on a dairy than on a grain farm. The value of the produce of each ought to be about the same. A just division should include a proportionate recompense to the owner for his increased investment; but if the tenant should supply all the extra feed which ought to be purchased on such a dairy farm, this would certainly restore the balance, and an equal division of the total proceeds would, we judge, be just for each party.

Tan-Bark for Strawberries.—"J. L. D.," Bloomsburg, Pa. A mulch of tan-bark will not sour the strawberries. The great objection to it is that the fine particles will adhere to and soil the fruit. Leaves or coarse hay or litter from the stable are better.

Information Wanted.—"G. H. E.," Napa Co., Cal., has two acres of land so situated that a creek runs through it and overflows it during winter, and in summer the ground is very dry. He asks what crop he should raise upon these two acres.—We are at a loss to advise in such an extreme case, and request some of our California readers to give us their opinion upon it. We would suggest, however, that here is an opportunity to overcome a difficulty by mechanical methods; damming out the water in winter and irrigating in the spring and summer, and then growing market crops suitable to a moist soil, as cabbages, celery, cauliflower.

Heaves.—"Teamster," Sharon, Pa. The cause of heaves or broken wind is not yet satisfactorily accounted for. It is said by some veterinarians to be incurable; still we never found a case in our experience that was not either greatly relieved or entirely cured by simple treatment. This was as follows: To aid the digestive power by simple tonics, and to feed the most nutritious and least stimulating food in small bulk, avoiding all dry, dusty food. For instance, a horse purchased by the writer for a very small sum, as being incurably diseased with the heaves, was fed three times a day with a painful of cut timothy hay and oats in the sheaf, soaked in hot water and fed when cold, mixed with three quarts of oats, corn, and rye bran ground together. A handful of salt was given in each feed, and occasionally a few raw potatoes or carrots cut and sprinkled with bran were given in addition. Nothing else was done, no medicine was given, no long hay was fed, and all dust in the feed was carefully guarded against. The result was an immediate change for the better, and no trouble from the disorder at all after a few weeks. The horse was then able to drive rapidly, and might be considered cured. On the other hand, horses have been known to become diseased immediately after feeding upon dusty clover hay, the inhalation of the dry seed-chaff or other dust doubtless causing the trouble.

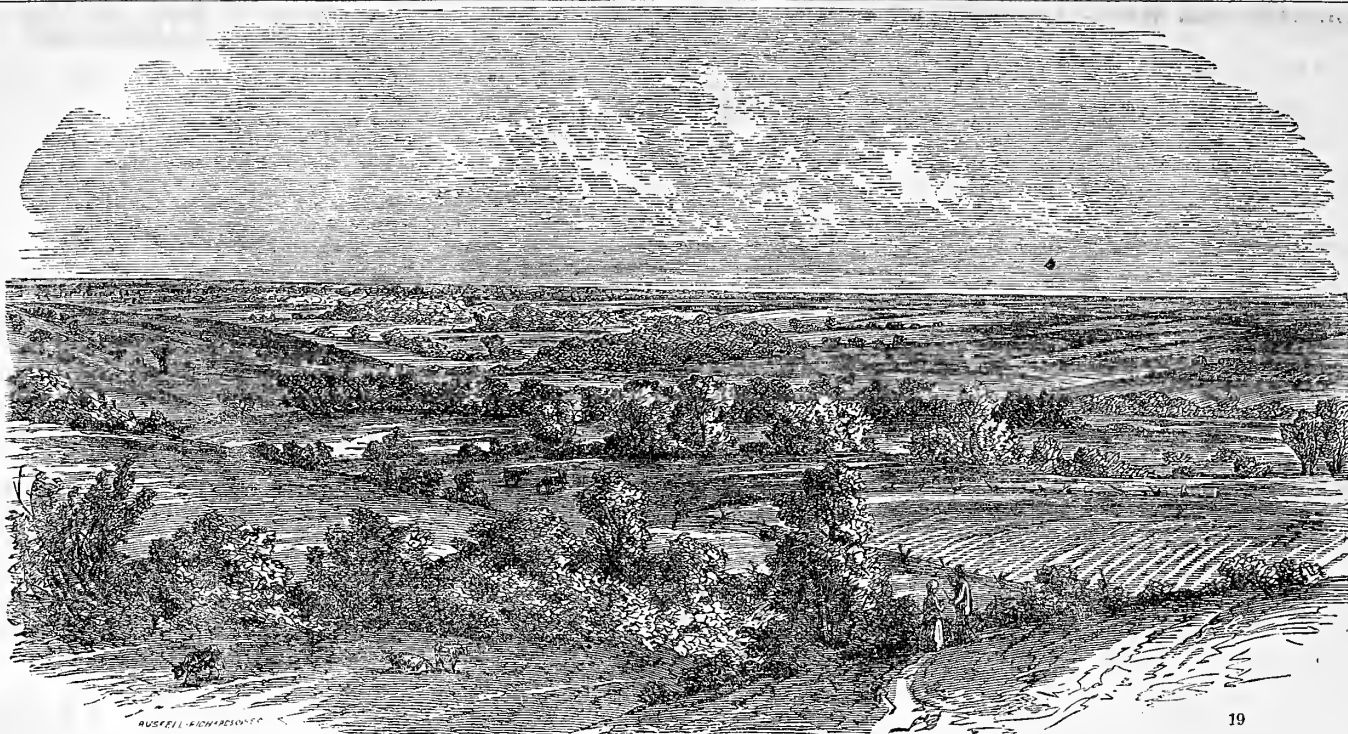

ON THE BLUE, BETWEEN CAMDEN AND CRETE, - CRETE AT THE LEFT, IN THE DISTANCE. REPRESENTATIVE VIEW OF LANDS FOR SALE BY THE BURLINGTON AND MISSOURI RIVER RAILROAD COMPANY.

IOWA AND NEBRASKA LANDS.

What Time in the Year is it Best to Buy Them?

THE BURLINGTON AND MISSOURI RIVER RAILROAD

Advertise that "Produce will pay for Land and Improvements several times over within their credit of ten years, with nothing to pay for four years but six per cent annual interest." Proceeds of crops are sometimes necessary and always convenient for paying this interest and annual installments, of principal after the fourth year as they accrue; hence it is wise to buy at such a time that all payments will fall due after harvest, on the heels of which the pork and beef crop follows. Delays of payment, asked for and granted, are generally "till after harvest."

These facts show that September, October, November, and December are the months most convenient for annual payments to mature; hence buying land "after harvest" is the best arrangement for ten prospective annual payments. Autumn is also the best season to "make a good ready" for next season's crop, such as selecting land, building a house, digging or boring a well, buying a wagon, team, plows, stock, etc., at best rates. Many wish to buy land, but can not come in person to do so before coming with their families. Such can write and specify the kind, location, quality; whether level or rolling prairie or valley and timber land, with running water; distance to Railroad station, market, etc.

The first payment of six per cent on the value of the land wanted can be remitted by Bank draft on Boston, New York, or Chicago, payable to order of GEO. S. HARRIS, Land Commissioner.

Prices range generally from three to ten dollars, averaging about six, though some lands are sold at one and two dollars per acre. On receipt of written application and funds, the best selection will be made that can be at price specified, and if on examination within one year the land thus bought is not satisfactory to the buyer, he can exchange it for any other unsold tract at same price; or for better land by paying the difference.

Nebraska Lands bought in 1873 will be entitled to a credit of twenty per cent premium, if one-half of it is improved and cultivated within two years from date of purchase.

A Deduction of 8, 15, or 10 per cent is made from long credit price in Iowa and Nebraska for full payment in one, two, or three years from date of purchase. Our gratuities, low prices, long credits, small annual payments, great products, and good markets enable every enterprising man to get a good farm and home in a rich, healthy, and beautiful country. Circulars giving full particulars, and in any quantity wanted, are supplied gratis.

A SECTIONAL MAP, on a large scale, showing the exact location of the Lands in Iowa, is sold at 30 cents, and a similar map of Nebraska Lands is sold at same price.

LAND BUYERS, in order to realize all the benefits we offer, should buy Land Exploring Tickets, via Burlington route, of W. D. Cowles, Agent, 317 Broadway, New York; W. H. Wisner, Agent, 59 Clark Street, Chicago, Ill.; or at C. B. & Q. R. Offices in Peoria, Mendota, Galesburg, Quincy, Ill. Or apply to

GEO. S. HARRIS, Land Commissioner, for Iowa Lands, at Burlington, Iowa; or for Nebraska Lands at Lincoln, Nebraska.

Civil Engineering School

OF UNION COLLEGE, SCHENECTADY, N. Y. Thorough course of instruction and field practice. Unrivalled collection of apparatus. Tuition, \$30 per term. Assistance rendered deserving students. For special information, address Prof. C. STALEY. For information concerning the College courses, Classical, Scientific, and Ecclectic, address E. N. POTTER, President.

BUILDING PAPER!

For Sheathing, Roofing, Deafening, Carpet Lining, and as a substitute for Plastering. Send for Samples and Circulars, to B. E. HALE & Co., 53 & 53 Park Place, N. Y., or ROCK RIVER PAPER CO., Chicago.

TALMAGE, SPURGEON.

T. De Witt Talmage is editor of *The Christian at Work*; C. H. Spurgeon, Special Contributor. They write for no other paper in America. Three magnificent Chromos. Pay larger commission than any other paper. **CHROMOS ALL READY.** No Sectarianism. No Sectionalism. One agent obtained 380 subscriptions in eighty hours absolute work. Sample copies and circulars sent free.

AGENTS Wanted.
H. W. ADAMS, Publisher, 102 Chambers Street, New York.

200 PIANOS AND ORGANS,

New and Second-hand, of First-class Makers, will be sold at Lower Prices for cash or on Installments, in City or Country, during this Financial Crisis and the HOLIDAYS, by HORACE WATERS & SON, No. 481 Broadway, than ever before offered in New York. Agents wanted for the sale of Waters' Celebrated Pianos, Concerto and Orchestral Organs. Illustrated Catalogues Mailed. Great Inducements to the trade. A large discount to Ministers, Churches, Sunday-Schools, Etc.

Joseph Gillott

STEEL PENS!
Sold by all Dealers.
No. 91 JOHN ST., NEW YORK.
HENRY HOE, Sole Agent, JOSEPH GILLOTT & SONS.

The Sugar Maker's Friend

More Agents wanted to canvass and sell Post's PATENT GALVANIZED METALLO EUREKA S&P SPOUT and BUCKET HANGER. Samples, Circulars and Terms sent on receipt of 20 cts. to pay postage.

Address C. C. POST, Manuf. and Patentee, Burlington, Vt.

LOVEJOY'S METALLIC WEATHER HOUSES

Indicate the changes in the weather, and are pretty mantel ornaments. The little lady appears in fair and the man in stormy weather, and they never make mistakes. Sent prepaid to any address, safely packed, upon receipt of \$2 (Two), by ALVAN L. LOVEJOY, Proprietor and Manufacturer, 229 Washington St., Boston. Special price to dealers.

Scribner's Lumber and Log-Book.

HALF A MILLION COPIES SOLD. This Book has been carefully revised, enlarged, and improved, with Doyle's Log-Tables added, and it is now the most full and complete book of its kind ever published. It gives correct measurement of all kinds of lumber, logs, plank, cubical contents of square and round timber, stave and heading bolt tables, wages, rent, board, capacity of cisterns, cord-wood tables, interest, etc., and has become the Standard Book throughout the United States and Canada. Be sure and get the *New Edition*, with Doyle's Log-Table. Ask your bookseller for it, or I will send one for 35 cents, post-paid. G. W. FISHER, P. O. Box 238, Rochester, N. Y.

\$1.50.---THE NURSERY.

A Monthly Magazine for Youngest Readers. Superbly Illustrated. Send stamp for a sample number. Now is the time to subscribe. JOHN L. SHOREY, 36 Bromfield Street, Boston.

AGENTS WANTED. GRAND BOOKS!
Cyclopaedia of Things Worth Knowing. 25,000 wants supplied. All you want to know about Farming, Gardening, Mechanics, Housekeeping, etc., etc. **THE POPULAR FAMILY BIBLE.** With Bible Dictionary and 500 Illustrations. The handsomest Bible made. **THE VOICE OF GOD.** A beautiful volume for every home. Terms, circulars, etc. **MILLER'S BIBLE & PUB. HOUSE.** 1102 & 1104 Sansom St., PHILADELPHIA, PA.

AGENTS WANTED
To canvass for the most popular publication of the day. Splendid chances for ladies and gentlemen in all parts of the States. Send for particulars. W. JENNINGS DEMOREST, 833 Broadway, N. Y.

FOR BOOKS, GAMES, Puzzles, Conjuring Tricks, Scientific Amusements, Colored Fire and other materials for Tableaux and Private Theatricals, Novelties and Home Amusements generally, see catalogue of HAPPY HOURS COMPANY, Publishers, 1 Chambers St., New York. Mailed to any address FREE.

Suggestions to Purchasers of Cabinet or Parlor Organs.

The following considerations may save some from the disappointment of purchasing inferior organs at high prices:

1. **Good Organs are very difficult to make.** An organ is not a coarse machine which can be successfully made by any ordinary workman. It is an exceedingly delicate piece of mechanism; a work of art. Its excellence depends on very nice conditions and extraordinary skill in workmanship; and its durability can be secured only by best possible material and construction.

2. **Difficulty of Selection.** It is impossible for an inexperienced person to judge what is a good organ and what a poor one from slight comparisons. Even a poor quality of tone may please at first, from its novelty, though it will soon become disagreeable. As to the durability of an organ no one can judge certainly from mere examination. Yet a poor organ will not last half as long as a good one, and so is dear at half the price, on this account alone.

3. **Many poor Organs are made.** There is great temptation to manufacturers to make poor, almost worthless, organs, because such can be made at half the cost of the best ones, and so will afford good profits even if sold at what appear to be low prices. Since the great popularity of these instruments the market is flooded with poor organs, which can indeed be sold at low prices but are very dear at that.

4. **The recommendations of dealers are likely to be prejudiced.** Dealers are tempted to recommend and sell those organs on which the largest discount is made to them, and these are always the poorest and most cheaply made instruments. Much allowance must be made therefore in listening to the representations of a dealer. Very often his judgment is biased by his pecuniary interests.

5. **An expedient to sell poor organs.** Makers of poor organs generally adopt the expedient of printing enormous prices in their price-lists, so that they can offer large discounts to purchasers, and thus make it appear that they are buying cheap! The printed prices are frequently double the real prices. So far from proving that an organ is cheap because a large discount is offered, there is reason to suspect that a maker who will misrepresent his price in his price-list will misrepresent his organ also in his description of it. There is always reason to suspect an article which is offered at a large discount.

6. **The lowest priced not cheapest.** In articles of this kind, in the manufacture of which there is so much opportunity to slight and cheapen, the lowest priced is almost never the cheapest. The poorest can be sold lowest, and almost always will be, while the best is as often the cheapest.

7. **How to be sure of a good organ.** There is a perfectly safe way to buy an organ, and to be sure of a good instrument. This is to purchase only an instrument by the very best maker, whose reputation is so thoroughly established, whose work has been so often proved best that there is no longer any question in the matter.

Most readers will know that this is the fact in regard to the Mason & Hamlin Organ Co. The first to introduce this class of instruments, their work has always stood indisputably at the head. Not only at HUNDREDS OF INDUSTRIAL COMPETITIONS in America, but at the most important WORLD'S FAIRS ever held—that just closed at VIENNA, and that at PARIS, in 1867—they have been awarded HIGHEST MEDALS for demonstrated superiority. They are the ONLY American Organs ever awarded any distinction at a World's Fair; the ONLY ones which command extensive sale in Europe, and the ONLY ones extensively recommended by both American and European musicians of eminence. How generally musicians regard them as unrivalled may be judged by any one who will look over the testimony of ONE THOUSAND in the TESTIMONY CIRCULAR of the Company.

8. **Also the lowest price.** The system of selling pursued by the Mason & Hamlin Co. secures fairness and the lowest price to every one. They print their lowest prices in their price-lists, which are therefore subject to no discount. These prices are not as low as those for which poor organs can sometimes be bought, but they are as low as organs of such excellence can be afforded by the makers having greatest facilities to make them cheapest. Those who have been offered organs at great discounts from prices of the manufacturers should compare net prices with those of the Mason & Hamlin Organ. Remember that they offer five-octave, double-reed Organs of that extraordinary excellence which characterizes all their work at \$110 each. The exorbitant prices for very inferior organs are from \$170 to \$225, and upwards.

The Mason & Hamlin Organ Co. have just REDUCED the PRICES of many styles, and are introducing new styles more beautiful and excellent than any they have made before, at low prices rendered possible only by reduced cost of material and labor.

Illustrated Catalogues and Price-Lists free. Address

MASON & HAMLIN ORGAN CO.,
Boston, New York, or Chicago.

GEO. P. ROWELL & CO.

conduct an agency for the reception of advertisements for American NEWSPAPERS—the most complete establishment of the kind in the world. Six thousand NEWSPAPERS are kept regularly on file, open to inspection by customers. No reading-room, however complete, receives one-twentieth of this number. Every Advertisement is taken at the home price of the paper, without any additional charge or commission, so that an advertiser, in dealing with the Agency, is saved trouble and correspondence, making one contract instead of a dozen, a hundred, or a thousand. A Book of eighty pages, containing lists of best papers, largest circulations, religious, agricultural, class, political, daily, and country papers, also magazines and all publications which are specially valuable to advertisers, with some information about prices, is sent Free to any address on application. Persons at a distance wishing to make contracts for advertising in any town, city, county, State, or Territory of the United States, or any portion of the Dominion of Canada, may send a concise statement of what they want, together with a copy of the Advertisement they desire inserted, and will receive information by return mail which will enable them to decide whether to increase, reduce, or forego the order. For such information there is no charge whatever. Publishers not only send their files free, but pay Messrs. GEO. P. ROWELL & Co. for their services. Orders are accepted for a single paper as well as for a larger list; for a single dollar as readily as for a larger sum. Address the American Newspaper Advertising Agency,

41 PARK ROW, N.Y.

The American Naturalist,

The only Magazine in the Country devoted to the popularization of

NATURAL HISTORY.

A Popular Entertaining and Instructive

MONTHLY MAGAZINE,

ILLUSTRATED WITH PLATES AND WOOD-CUTS.

A. S. PACKARD, Jr., and F. W. PUTNAM,

Editors and Proprietors.

R. H. WARD, Troy, N. Y.,

Associate Editor of Microscopical Department.

As the articles in the NATURALIST, though of a popular and non-technical character, are written by authorities on the various subjects, each volume forms an ILLUSTRATED ENCYCLOPEDIA OF NATURAL HISTORY of great value as a work of reference to the student and general reader, as well as to those more immediately interested in the STUDY OF NATURE. The NATURALIST is for the STUDENT, the TEACHER, the GENERAL READER, the AGRICULTURIST, the FARMER, the YOUNG, and the LOVER OF NATURE.

Vol. 8 begins with the number for Jan., 1874.

TERMS.—Subscription \$4.00 a year, strictly in advance. Single Numbers 35 cts.

Subscription to Vol. and the 7 preceding vols, in numbers, \$34.00, or bound, \$36.00.

Address AMERICAN NATURALIST,
Salem, Mass.

THE

Young Housekeeper's Friend.

By MRS. CORNELIUS.

Price \$1.50. Interleaved, \$2.25.

The most popular and reliable COOK-BOOK and guide for the duties of the household published. The standard work on these subjects. 50th thousand now ready. Copies sent by mail on receipt of price.

THOMPSON, BROWN & CO., Boston, Mass.

NEW YORK DAILY WITNESS,

\$3 a Year, 75 Cents a Quarter.

NEW YORK WEEKLY WITNESS,

SIZE OF N. Y. TRIBUNE,

\$1 a Year, or 25 Cents per Quarter.

Send for Sample Copies.

ARTHUR'S

Illustrated Home Magazine.

Bright, cheerful, earnest, and progressive, the "HOME" takes rank with the best periodicals of the day. It is

The Cheapest First-Class Magazine

in the country, and more thoroughly identified with the people in their social and domestic life than any other. It is

The GREAT HOUSEHOLD MAGAZINE OF AMERICA, and within the reach of all. Every yearly subscriber has a choice, free, of one of the following large and elegant steel engravings:

"PEACE BE UNTO THIS HOUSE."

"THE CHRISTIAN GRACES."

"THE ANGEL OF PEACE."

"BED-TIME."

"THE WREATH OF IMMORTELLES."

No picture of the size and quality of these sells in the print stores for less than \$5. A new Serial Story, entitled

"Window Curtains,"

By T. S. Arthur, will be commenced in the January number. TERMS.—\$2.50 a year, with a reduction for clubs. For sale by all newsvendors. Sample numbers 15 cents.

Agents WANTED.—Larger commissions and better inducements offered than by any other publication. Valuable and very desirable premiums. Address T. S. ARTHUR & SON, 809 Chestnut Street, Philadelphia.

TAKE

THE PRAIRIE FARMER FOR 1874.

IT WILL AIM:

TO help on the great work of organizing the farmers by means of the Patrons of Husbandry and Farmers' Clubs.

TO lead the van in the contest of the people with railroad and other monopolies.

TO treat of the most approved practices in agricultural and horticultural pursuits.

TO set forth the merits of the best breeds of domestic animals, and to elucidate the principles of correct breeding.

TO furnish the latest and most important industrial news, at home and abroad.

TO discuss the events and questions of the day, without fear or favor.

TO further the work of agricultural and horticultural societies.

TO advocate industrial education, in the correct sense of the term.

TO provide information upon the public domain, Western soils, climate, etc.

TO answer inquiries on all manner of subjects which come within its sphere.

TO give, each week, full and reliable market, crop, and weather reports.

TO present the family with choice and interesting literature.

TO amuse and instruct the young folks.

TO be, in a word, an indispensable and unexceptionable farm and fireside companion, in every respect.

TERMS: Single copy, \$2.50 per annum, in advance. Two Copies (to one old subscriber and one new, or two new), ordered at same time, \$4.00. Liberal reduction to clubs. Three months on trial, 50 cents. Sample number free.

Liberal Cash Commissions to Agents.

Great Inducements to Farmers' Clubs and Granges.

Full Information and Complete Canvassing Outfit furnished free, on application to

THE PRAIRIE FARMER COMPANY,
Chicago, Illinois.

THE NEW YORK EVENING POST,

Edited by William Cullen Bryant and Parke Godwin, assisted by the strongest talent that can be engaged, has for more than half a century maintained the same principles of Freedom and Progress through all changes of parties and policies.

The Evening Post is equal to any other journal as a newspaper, and is complete in its Political, its Literary, its Scientific, its Agricultural, and its Commercial Departments.

Weekly, \$1.50; Semi-Weekly, \$3.00.

Specimen copies, containing liberal clubbing terms, sent free. Address

WM. C. BRYANT & CO., New York.

Taylor's Rotary Engine,

Adapted to any place where power is needed. For hoisting purposes, Vessels, Boats, etc. Is simple, reverses instantly, runs either way. Has no dead center. Takes up but little room. Excelsior Portable and Agricultural Engines. Heater inside Boiler: Cylinder incased in Steam always, using DRY Steam. Best in use. Circular Saw-Mills—Single and Double. The Diamond State Separators—simplest, lightest-running, and cheapest for its capacity in the market. Westminster Triple-gear Horse Powers—on wheels or down. Iron Horse Trains—has no superior. Lime and Fertilizer Spreaders—warranted to spread from 1 to 100 bushels per acre as desired. Send for Circulars. Address TAYLOR MANUFACTURING CO., Westminster, Md. Agents wanted.

FOR SALE.

A CHOICE FARM of 80 1/4 acres, with good 2-story frame house, barns, stables, etc.; five hedges, orchards, and vineyard; superior prairie and timber land, nearly all under cultivation or in pasture; well watered; suitable for stock or grain farm; in a most excellent neighborhood, and considered one of the most healthy and beautiful homes in Cooper County, Missouri; 1 1/2 miles from Vermont station on "Osage Valley and Southern Kansas R.R.," and about 6 miles from the Missouri Pacific R.R.

In order to make as prompt a sale as possible, the above is offered at the extreme low price of \$30 per acre—part out time if desired; interest 10 per cent.

For further particulars apply to BANKING HOUSE OF AEHLE DUNNICA & CO., Bonville, Mo., Or DONNELL, LAWSON & CO., BANKERS, No. 4 Wall Street, New York.

THE INDEPENDENT.

UNSECTARIAN RELIGIOUS WEEKLY.

Thirty-two Pages, Size of "Harper's Weekly."

As in the past, THE INDEPENDENT will continue in the future to be the largest and by far the best religious weekly published in the world. A large number of the first writers in America and Europe are regular contributors. It has departments devoted to Religion, Literature, Poetry, Science, Missions, Sunday-schools (explanations and comments upon the International Series of Sunday-school Lessons), Education, Ministerial Register, Editorials, Editorial Notes, Young and Old, Commercial Interests, Dry Goods (with latest and most correct Quotations), Market Reviews (comprising latest Quotations of Groceries, Country Produce, General Markets, etc., etc.), Finance, Insurance, and the Farm and Garden; making it by far the best paper for the clergyman, business man, and family.

Among the contributors to THE INDEPENDENT during 1873 may be mentioned: LOUISA M. ALCOTT, JACOB ABBOTT, MARY CLEMMER AMES, H. W. BELLOWES, D.D., HORACE BUSHELL, D.D., LEONARD BACON, D.D., C. P. CRANCH, T. L. CUYLER, D.D., LYDIA MARIA CHILD, JAMES FREEMAN CLARK, D.D., ROSE TERRY COOKE, F. C. EWER, D.D., GEORGE P. FISHER, D.D., WILLIAM LLOYD GARRISON, MRS. GREENOUGH, H. H., GAIL HAMILTON, T. W. HIGGINSON, FATHER HYACINTHE, GILBERT HAVEN, EDWARD E. HALE, J. J. JARVES, CHARLES KINGSLEY, JAMES MCCOSH, L.L.D., W. E. H. LECKY, RAY PALMER, D.D., J. G. PIATT, ELIZABETH STUART PHELPS, HIRAM RICH, A. P. STANLEY, D.D., R. H. STODDARD, HARRIET PRESCOTT SPOFFORD, J. P. THOMPSON, D.D., CELIA THAXTER, W. M. TAYLOR, D.D., J. T. TROWBRIDGE, HENRY WILSON, SUSAN WARNER, JOHN G. WHITTIER.

Its Premium List is extensive and liberal. Our New Edition for 1874 is an elegant Chromo, entitled "Memories of Childhood," from an original Oil painting by the world-renowned artist, F. B. CARPENTER, which was painted expressly for THE INDEPENDENT.

We also offer the beautiful Chromos "Good-night Frolic" and "So Tired"; also Steel Engravings of "The First Reading of the Emancipation Proclamation," "Authors of the United States," "President Grant," "Vice-President Wilson," and "Edwin M. Stanton, late Secretary of War."

TERMS OF SUBSCRIPTION:

Only \$3.00 per year, including the Chromos "Good-night Frolic" and "So Tired," unmounted; or "Memories of Childhood," unmounted; or the Steel Engraving, "Grant and Wilson," or "Edwin M. Stanton," \$3.25 per year—Chromos "Good-night Frolic" and "So Tired," mounted on binders' board; or "Memories of Childhood," mounted on canvas, rolled, ready for framing; or Steel Engraving, "First Reading of the Emancipation Proclamation," or "Authors of the United States." \$3.50 per year—Chromos "Good-night Frolic" and "So Tired," mounted on stretchers, \$9.00 and \$ New Subscribers—the "Providence Wringer."

Agents Wanted.—Exclusive Territory Given.—Large Commissions Offered.

Send for sample copy, with full List of Premiums and inducements to Agents. SUBSCRIBE NOW! Remittances to be sent to

HENRY C. BOWEN, Publisher, No. 3 PARK PLACE, New York. P. O. Box 2787.

EMPLOYMENT FOR ALL. AGENTS WANTED FOR The Independent.

A first-class Family and Religious Journal. From \$100 to \$200 easily made. Each subscriber receives a premium worth more than the subscription price. Our new elegant Chromo, "Memories of Childhood," size 11x21, now ready for delivery. We want special Agents for every town. For Terms and List of Premiums address H. C. BOWEN, 3 Park Place, New York.

BOOKS ON ARCHITECTURE.

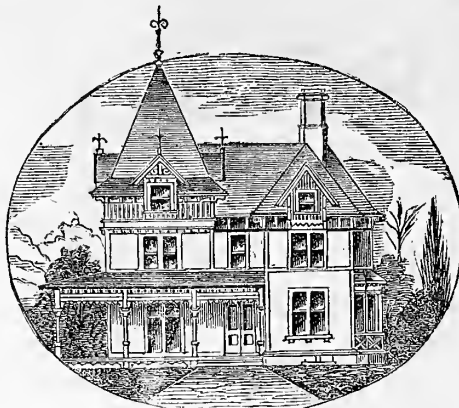

A Practical Book, one that Architects, Builders, and Carpenters can not afford to be without, entitled

DETAIL, COTTAGE, AND CONSTRUCTIVE ARCHITECTURE,

Containing 76 FULL PLATES, 20 plates more than before offered in a similar work for Ten Dollars.

Published under the direction of A. J. BICKNELL.

Showing a great variety of Designs for Cornices, Brackets, Windows and Window Caps, Doors, Piazzas, Porches, Bay and Dormer Windows, Observatories, Towers, Chimney Tops, Balconies, Canopies, Scrolls, Gable and Sawed Ornaments, Fences, Stairs, Newels, Architraves, Mantels, Plaster Finish, etc., etc., including Forty-five Perspectives, Elevations and Plans of Modern Designs for Cottages with Details, and Eighteen Elevations of Summer Houses, Villas, Seaside Cottages, and Country Houses, together with Fourteen Designs for Street and Store Fronts, with Inside Finish for Stores and Banks; also, Framing for Dwellings, Barns, Exhibition Buildings, Roofs, Bridges, etc., etc., making in all a Practical Book for Architects, Builders, Carpenters, and all who contemplate Building or Remodeling Wood, Stone, or Brick Buildings. One Large Quarto Volume, sent Free by Mail or Express, on receipt of Price.....\$10.00.

Bicknell's Village Builder, And SUPPLEMENT.

THE VILLAGE BUILDER shows Elevations and Plans for Cottages, Villas, Suburban Residences, Farm Houses, Stables and Carriage-Houses, Store Fronts, School-Houses, Churches, Court-Houses, and a Model Jail. Also, Exterior and Interior Details for Public and Private Buildings, with approved Forms for Contracts and Specifications, containing fifty-five Plates, drawn to Scale, giving the Style and Cost of Building in different sections of the Country. Revised Edition, with three additional Plates, showing inside finish for Stores, Banks, and Insurance Offices, and two Elevations and Plans for low-priced Dwellings; also, a variety of Details added to several Plates. Quarto Volume, issued February 1, 1872. THE SUPPLEMENT contains Twenty Plates, showing Eighteen Modern and Practical Designs for Country and Suburban Residences of moderate cost, with Elevations, Plans, Sections, and a Variety of Details, all Drawn to Scale. Also, a Full Set of Specifications, with Approved Form of Contract and Estimates of Cost. The Two Books in one Volume, price.....\$12.00. Parties desiring the Supplement only, will be supplied, post-paid, on receipt of \$5.00.

ARCHITECTURE.

By CUMMINGS & MILLER.

A Practical Book on Architectural Details; containing over One Thousand Designs and Illustrations, showing the manner of constructing Cornices, Doorways, Porches, Windows, Verandas, Railings, French Roofs, Observatories, Piazzas, Bay-Windows, Cut-Stone Work, various styles of Modern Finish, and Street Fronts of Houses, Stores, etc., etc. One Large Quarto Volume. Price, post-paid....\$10.00.

Modern American Architecture.

By CUMMINGS & MILLER.

Containing Designs and Plans for Villas, Farm-Houses, School-Houses, Cottages, City Residences, Churches, etc. Also, Trussed Roofs, Interior Store Finish, and many Exterior Details. In One Large Volume, bound in Cloth, 54 Plates, price.....\$10.00.

Loth's Practical Stair-Builder.

A complete Treatise on the Art of Building Stairs and Hand-Rails. Designed for Carpenters, Builders, and Stair-Builders. Illustrated with Thirty Original Plates. By C. EDWARD LOTH, Professional Stair-Builder. One large Quarto Volume. Bound in Cloth. Price.....\$10.00.

Address

ORANGE JUDD COMPANY,

245 BROADWAY, NEW YORK.

THE NEW STORY.

A Man of Honor.

By GEORGE CARY EGGLESTON.

Finely Illustrated.

The publishers take pleasure in commending this as one of the most charming stories that has been presented to the American people. Mr. Eggleston has given to it, with rare fidelity, the local coloring of the part of the country where its scenes are laid. It is a realistic story of life in the Old Dominion. Its people are ladies and gentlemen. Robert Pagebrook, the "Man of Honor," is every inch a man, and his sayings and doings at once attract and hold the reader's attentive interest. It is a love-story, too, and has the merit, which is not as common as it might be nowadays, of ending to the reader's entire satisfaction.

NOTICES BY THE PRESS.

A capital picture of Life in Old Virginia before the war is to be found in Mr. George Cary Eggleston's "A Man of Honor." Virginian hospitality, Virginian cousinship, Virginian housekeeping, are portrayed in accurate and attractive colors. It is a life which the author has himself known and loved, and he writes of it with a warmth that comes from the heart.—N. Y. Evening Post.

Really readable in the most refreshing sense of the term—a story of the most amusing and attractive interest.—St. Louis Times.

It is written in an off-hand manner, and is bright and amusing.—Worcester, Mass., Spy.

With Virginian life as a specialty, Mr. Eggleston has drawn a simple, straightforward, truthful, and withal, artistic picture of Southern society. It is sketchy, perhaps too much so, but the sketches are all vigorous and show the hand of a practiced artist. In forming the characters of his book it is evident that Mr. Eggleston has drawn oftener on his memory than on his imagination; that he has lived among the people whom he describes, has heard them talk, and seen them under all the moods of ordinary life.—Boston Daily Advertiser.

CONTENTS.

- Chapter 1. Mr. Pagebrook gets up and calls an Ancient Lawgiver.—2. Mr. Pagebrook is Invited to Breakfast.—3. Mr. Pagebrook Eats his Breakfast.—4. Mr. Pagebrook Learns Something about the Customs of the Country.—5. Mr. Pagebrook Makes some Acquaintances.—6. Mr. Pagebrook Makes a Good Impression.—7. Mr. Pagebrook Learns Several Things.—8. Miss Sudie Makes an Apt Quotation.—9. Mr. Pagebrook Meets an Acquaintance.—10. Chiefly Concerning "Foggy."—11. Mr. Pagebrook Rides.—12. Mr. Pagebrook Dines with his Cousin Sarah Ann.—13. Concerning the Rivulets of Blue Blood.—14. Mr. Pagebrook Manages to be in at the Death.—15. Some very Unreasonable Conduct.—16. What Occurred Next Morning.—17. In which Mr. Pagebrook Bids his Friends Good-by.—18. Mr. Pagebrook Goes to Work.—19. A Short Chapter, not very Interesting, perhaps, but of some Importance in the Story, as the Reader will probably Discover after awhile.—20. Cousin Sarah Ann Takes Robert's Part.—21. Miss Barksdale Expresses some Opinions.—22. Mr. Sharp Does his Duty.—23. Mr. Pagebrook Takes a Lesson in the Law.—24. Mr. Pagebrook Cuts Himself Loose from the Past and Plans a Future.—25. In which Miss Sudie Acts very Unreasonably.—26. In which Miss Sudie adopts the Socratic Method.—27. Mr. Pagebrook Accepts an Invitation to Lunch and Another Invitation.—28. Major Pagebrook Asserts Himself.—29. Mr. Barksdale the Younger goes upon a Journey.—30. The Younger Mr. Barksdale Asks to be Put upon his Oath.—31. Mr. William Barksdale Explains.—32. Which is also the Last.

ILLUSTRATIONS.—By M. WOOLF.

"Now I've Got You" (Frontispiece).—Mr. Robert Pagebrook was "Blue."—"I Fall at Once into a Chronic State of Washing up Things."—"Foggy."—Cousin Sarah Ann.—The Rivulets of Blue Blood.—Miss Sudie Declares Herself "so Glad."—"Let Him Serve it at Once, Then."—"Very Well, Then."—"I'm as Proud and as Glad as a Boy with Red Morocco Tops to his Boots."

PRICE, POST-PAID\$1.25

ORANGE JUDD COMPANY,

245 BROADWAY, NEW YORK.

BOOKS FOR FARMERS and OTHERS.

[Published and for sale by the Orange Judd Company, 245 Broadway, New York. Any of these books will be forwarded by mail, post-paid, on receipt of price.]

Table listing various books for farmers and others, including titles like 'American Cattle', 'Rural Architecture', 'American Farm Book', etc., with prices.

O. J. Co. keep in stock the following Books: Architecture, By Cummings & Miller. \$10 00. Architecture, Modern American. By C. & M. 10 00.

Table listing various books for farmers and others, including titles like 'Art of Saw Filing', 'Bailey's Our Own Birds of the United States', 'Bement's Poultry Companion', etc., with prices.

Table listing various books for farmers and others, including titles like 'PAY', 'PAY', 'PAY', etc., with prices.

HEARTH AND HOME FREE. A PRESENT. We have given away as premiums and have sold a large number of the \$12 and \$20 Beckwith Sewing Machines... ORANGE JUDD COMPANY, 245 BROADWAY, NEW YORK. FREE FOR ONE YEAR.

Beckwith Sewing Machines ONLY \$12. ONLY \$20.

We have offered as a Premium, and also for sale, for more than a year past, the

Beckwith Sewing Machine, which has been fully described in previous numbers of this paper. We have already given and sold more than one thousand of these machines, and testimonials of satisfaction have come from every quarter.

We still offer the Beckwith Sewing Machine, Improved, price \$12. A new and very simple braiding-foot has been made, by which a child can sew on braid without the least trouble, following any desired pattern with ease; also a new arm, spiral spring and lever for raising the presser-foot, all of which are now set in a position that leaves the needle free to be threaded. The joint is much enlarged, and the machine is otherwise greatly strengthened and improved.

Each of these machines is put in a neat, compact box, with hemmer and guide, oil-can with oil, thread, different-sized needles, etc., with full Printed Directions for using. On receipt of \$12 we will send one of these machines to any address, expressage to be paid by the purchaser.

The Machine as a Premium.

We will give one of these \$12 machines to any one who will collect and forward eight subscribers for Hearth and Home one year at \$3 each; or sixteen subscribers to American Agriculturist for one year, at \$1.50 each, expressage on the machine to be paid by the recipient of it.

THE BECKWITH PORTABLE Family Sewing Machine. PRICE \$20. Enlarged and Improved. ITS WEIGHT IS 7 POUNDS.

While we continue the offer of the Improved \$12 Machine as heretofore, we now offer the new

Portable Family Machine,

price \$20, which comprises all the excellencies of the former, with many valuable improvements. Its size and power are increased, and its capacity thus very much enlarged, without impairing its portability. There have been added cam and eccentric movement, a balance-wheel, and also an oscillating needle-clamp, by which the length of stitch can with the greatest ease be changed to the finest shade of variation without touching the needle.

To any one sending us \$20, we will send one of the Machines (packed in a neat, portable case, with handle to carry it easily), expressage to be paid by purchaser. If, after having the Machine 30 days, and giving it a fair trial, it does not give satisfaction, upon the return of the Machine, express charges paid, we will refund the \$20.

The Machine as a Premium.

We will give one of these \$20 Machines to any one who will collect and forward to us Fifteen Subscribers to Hearth and Home for one year at \$3 each, or Thirty Subscribers to American Agriculturist for one year at \$1.50 each, or One Hundred at \$1 each, expressage on the Machine to be paid by the recipient of it.

Almost any lady can readily secure the small number of subscribers required to get either the \$12 or the \$20 Machine as described above; or some friend can thus obtain it for her as a present.

ORANGE JUDD COMPANY, 245 BROADWAY, NEW YORK.

GREAT DEDUCTION. TEAS and COFFEES

At Wholesale Prices.

Increased Facilities to Club Organizers.

Send for New Price-List.

THE GREAT AMERICAN TEA COMPANY,
(P. O. Box 5643.) 31 and 33 Vesey St., New York.

WOOD, TABER & MORSE,
Eaton, Madison Co., N. Y.

MANUFACTURERS OF

Steam-Engines,

Portable, Stationary, and Agricultural.

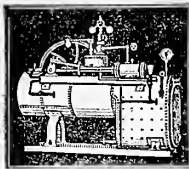

Hundreds in use in Shops, Printing Rooms, Mills, Mines, and on Farms and Plantations for Grain Threshing, Food Cooking for Stock, Cotton Ginning, Sawing, etc. Circulars sent on application.

A SPLENDID HOLIDAY PRESENT,

Unequaled for Beauty and Excellence.

A MARVELOUS OFFER.

JEROME THOMPSON'S MAGNIFICENT PICTURE,

"The Old Oaken Bucket."

The original oil Chromo, after this celebrated picture. Size 15x26 inches. Price \$15.00. The best and most popular landscape Chromo ever published in America, in all its original beauty and excellence, given free as a premium to each \$3.00 Yearly Subscriber to DEMOREST'S MONTHLY MAGAZINE. Ten cents extra for postage on the Chromo, or when mounted, ready for framing, fifty cents, which includes transportation. Address
W. JENNINGS DEMOREST, 838 Broadway, N. Y.

National Temperance Almanac And Tectotaler's Year-Book for 1874.

Contains 72 pages of Statistics of Intemperance, Anecdotes, Stories, Puzzles, Choice Illustrations, Post-Office Address of Officers of State and National Bodies, a full Directory of all Temperance Organizations in New York City and Brooklyn, all Temperance Publications and Papers, etc., etc.

Sent by mail on receipt of price. Ten cents single copies; \$1 per dozen. Address

J. N. STEARNS, Publishing Ag't,
58 Reade Street, New York.

The Hutchinson Burner.

(Price, 35 Cents, by Mail.)

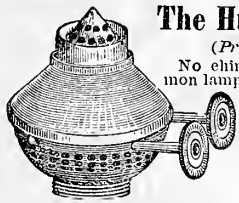

No chimney needed. Fits the common lamps, and burns kerosene with a clear, steady flame two inches high, or any less light desired. For safety, convenience, and economy, unequaled. Sent by mail for 35 cents; two for 60c., with wicks. Write to
HUTCHINSON & CO.,
Cayuga, N. Y.

LOVEJOY'S NEW STYLE GLASS-CUTTER and PUTTY-KNIFE



is a better tool for cutting glass than anything ever offered for the purpose. Any child can use it. Every housekeeper, farmer, and mechanic should have one. Sent in neat box, prepaid, to any address upon receipt of 50 cents and letter-stamp by
ALVAN L. LOVEJOY,
229 Washington St., Boston.

ADVERTISING RATES.

American Agriculturist. ENGLISH EDITION.

Inside Pages, \$1.50 per line (agate), each insertion.
Open Pages (open without cutting), \$2 per line.
Last Page, and 2d and 3d Cover Pages—\$2.50 per line.
Page next to Reading and Last Cover Page—\$3.00 per line.
No advertisement inserted for less than \$5.00.

GERMAN EDITION.

Inside Pages, 25 cents per line, each insertion.
Business Notices and Last Page, 40 cents per line.
No advertisement inserted for less than \$1.00.

Hearth and Home.

Inside Pages, per line (agate), each insertion.....50 cents.
Business Notices, 7th Page, and Last Page.....75 cents.
Reading Notices per line.....\$1 00
No Advertisement inserted for less than \$2.00.

No Advertisement of Medicines or Humbugs received.
Address all orders to the

ORANGE JUDD COMPANY,

245 BROADWAY, NEW YORK.



THE

WASHINGTON LIFE INSURANCE CO.,

155 Broadway, New York.

ASSETS, \$3,500,000.

CYRUS CURTISS, President.

W. A. BREWER, Jr., Vice-President and Actuary.
W. HAXTUN, Secretary.

Dividends paid annually from date of policy, and are non-forfeitable by Charter.

Premiums are required in Cash. Dividends are paid in Cash. Assets are held in Cash.

All profits divided among the Policy-holders.

1874. BETTER THAN EVER! 1874.



THE GREAT ILLUSTRATED

Rural, Literary & Family Weekly.

THIS FAMOUS WEEKLY, which has been the Leading and Largest Circulating Journal of its Class for over Twenty Years, not only "still lives" but purposes to render its ensuing (XXIXth) volume better than any yet published. MOORE'S RURAL is the STANDARD AUTHORITY on Agriculture, Horticulture, and Domestic Affairs, and a Choice, High-Toned, and Popular Literary and Family Paper. No other journal in its sphere has such a large and able corps of Editors and Contributors, and none comprises so many Departments, or so great a variety of Subjects, Illustrations, etc. National in Character and Objects, and adapted to both Town and Country, it has ardent admirers in every State, Territory, and Province on the Continent. Ever earnestly advocating the Rights and Interests of the Industrial Classes, MOORE'S RURAL NEW-YORKER has long been the

FARM AND FIRESIDE FAVORITE,

and to-day has no peer in its important sphere of Journalism. Believing in Tact, Talent, and the discussion of such Timely Topics as are of paramount interest to Producing People, it employs the ablest talent in the land, and furnishes the BEST PAPER FOR

THE FARMER,
THE HORTICULTURIST,
THE STOCK GROWER,
THE DAIRYMAN,
THE HOUSEWIFE, etc.

In the future no pains will be spared to render the paper indispensable to the Rural and Industrial Population of the Country, and a welcome guest at every fireside it may visit. The Reading for the Family and Young People, with appropriate illustrations, will receive increased care and attention, while none of the Practical Departments will be neglected—our aim being to EXCEL in every and all features, and to furnish the best combined RURAL, LITERARY, and FAMILY NEWS-PAPER obtainable.

STYLE, TERMS, &c.

MOORE'S RURAL NEW-YORKER contains Sixteen Quarto Pages, weekly, finely and profusely Illustrated, and neatly printed. Only \$2.50 per year—in clubs of ten or more, \$2 per copy. Now is the Time to Subscribe for 1874. Great Premiums or Cash Commissions to Club Agents. Specimens, Premium Lists, etc., sent FREE to all disposed to act as Agents. Address

D. D. T. MOORE, New York City.

Gazzam Collection Agency,

Principal Office, 229 BROADWAY, NEW YORK.

HENDERSON'S BOOKS

ON

FLOWERS AND GARDENING.

Practical Floriculture.

A Guide to the Successful Propagation and Cultivation of Florists' Plants.

By PETER HENDERSON,

Author of "Gardening for Profit."

Beautifully Illustrated. Price, Post-paid, \$1.50.

In this work, which has everywhere become so deservedly popular, not only is the whole "art and mystery" of propagation explained, but the reader is taught how to plant and grow the plants after they have been propagated. The work is not one for florists and gardeners only, but the amateur's wants are constantly kept in mind, and we have a very complete treatise on the cultivation of flowers under glass, or in the open air, suited to those who grow flowers for pleasure as well as those who make them a matter of trade. The work is characterized by the same radical common-sense that marked the author's "Gardening for Profit," and it holds a high place in the estimation of lovers of floriculture.

"Practical Floriculture" came to hand safely. I am much pleased with it. I ordered "Gardening for Profit" before it was ready for delivery, and during all the years that I have had it I have never once made a failure when I have followed its guidance.

JAMES LYNN,

Farmer and Gardener for Nicolett House,
January 23, 1873. Minneapolis, Minn.

I bought both "Gardening for Profit" and "Practical Floriculture" as soon as they were published, and have found them invaluable in their assistance in gardening operations.

D. H. CHADWICK,

April 15, 1873. Morgantown, W. Va.

I started my greenhouse last fall, and with the help of "Practical Floriculture" I have succeeded beyond my utmost expectations. There is more plain common sense in it than in all the rest put together. I speak the truth and lie not.

J. C. MCCONNELL,

February 4, 1873. Carlinsville, Illinois.

Last October I bought "Practical Floriculture," constructed a greenhouse, and went to work implicitly following its instructions (being entirely ignorant of the business). I have astonished myself and everybody else with my success, all due to this thoroughly plain and practical book.

May 1, 1873. W. B. CALDWELL, Paris, Ill.

Gardening for Profit.

A Guide to the Successful Cultivation of the Market and Family Garden.

By PETER HENDERSON.

Finely Illustrated. Price, Post-paid, \$1.50.

The success of this book has probably not been equaled by that of any horticultural work of the present day. Its popularity is due to the fact that it tells just what people wish to know—the way in which the author made money by gardening—and puts in a plain, striking light all the requisites to success. The writer was not afraid to have people know that he cultivated his land for profit, and more than that, he was quite willing that all should know and practice, if they chose, the very processes which he had found most conducive to the desired end. The late Horace Greeley said of this book: "There are marvels of transformation and rapid reproduction recorded therein which might well shame the dull fancy of the author of Aladdin or of Koolah. There is no theory about it; a man who has made himself rich by market-gardening plainly tells our young men how they can get rich as easily as he did, and without wandering to California or Montana for it either." And tens of thousands who have read and profited by the work could give similar testimony. It is unquestionably the most thorough and the best book of its kind that has yet come from the hand of an American author.

I was an early purchaser of "Gardening for Profit," a reading of which made the possession of "Practical Floriculture" a necessity. I sincerely thank the writer for giving us non-professionals what we have so long needed—some plain common-sense directions for our assistance—and for having exploited some outrageous humbugs which have been perpetuated in all previous works on gardening and floriculture from time immemorial, tending to produce the conviction that nothing but professional skill could raise a vegetable or flower.

LUTHER NEWCOMB,

May 4, 1873. Montpelier, Vt.

Either of the above books sent post-paid on receipt of price by

ORANGE JUDD COMPANY, 245 Broadway, N. Y.

OUR SPECIAL PREMIUMS!

TWENTY FARMS TO BE GIVEN AWAY!

SECURE A GOOD HOME,

AND

SECURE IT NOW.

The Best Chance Ever Offered

FOR

Men and Women, Boys and Girls

TO

Secure Good Homes!

There are throughout the Eastern and Middle States thousands of people anxious to secure for themselves homes in the West. Many of these have not the means to spare to make a tour of examination of the different portions of the West and then purchase the lands they so much need. To meet the wants of some of these the Publishers of the *American Agriculturist* and HEARTH AND HOME have secured a number of farms in one of the most beautiful, fertile, and healthful locations in the great West, and now offer them as Special Premiums to Agents for procuring subscribers to the *American Agriculturist* or HEARTH AND HOME or both.

Location of the Lands.

These lands are within the limits of the well-known and popular National Colony, located in Southern Minnesota and Northern Iowa. In beauty, fertility, and adaptability to general agriculture they are not surpassed by any in the United States. The Colony is organized upon temperance principles, and no intoxicating liquors are allowed to be sold within its limits. The St. Paul and Sioux City Railroad is completed, and regular trains are running through the Colony lands, thus affording access to the best markets. The lands are being rapidly settled by moral, industrious, and enterprising people, thus insuring good society, churches, schools, and all the comforts and conveniences of an old-established community. There are now over fifteen hundred families within the Colony limits. This rapidity of settlement insures a rapid increase in the value of property, so that those who secure these premiums will get property not only valuable to-day, but which can not fail to increase in value very rapidly.

How to Get Them.

We can offer eight farms of forty acres each; eight of eighty acres each, and four of one hundred and sixty acres each for subscribers to our publications upon the following terms, viz:

Forty Acres for 310 subscribers to the *American Agriculturist*, at \$1.50 each; or 155 to HEARTH AND HOME at \$3.00 each, or 170 to both papers at \$1.00 each.

Eighty Acres for 620 subscribers to *American Agriculturist* at \$1.50 each; or 310 to HEARTH AND HOME at \$3.00 each, or 340 to both papers at \$4.00 each.

One Hundred and Sixty Acres for 1240 subscribers to the *American Agriculturist* at \$1.50 each; or 620 to HEARTH AND HOME at \$3.00 each, or 680 to both papers at \$4.00 each.

Value of these Lands.

These lands were appraised more than three years ago by disinterested men at **\$8 per Acre**,

and the rapid rate of settlement in the National Colony will increase their value to from **\$25 to \$50** per acre in a very few years. Better lands can not be found anywhere.

Selection of the Farms.

Persons securing any of these premiums will receive a certificate to that effect, with which they may locate the lands themselves, or have some one else do it for them, or we will have it done without charge by a disinterested person, and forward the deed by mail.

Go to Work at Once.

Now we are confident there are among our readers several thousand men and women, boys and girls, who could easily secure one of these valuable premiums. The winter's leisure (too often wasted) employed in this work could hardly fail to secure one of these farms, and thus prove the foundation of a comfortable fortune. Such an opportunity for securing a home has rarely, if ever, been offered before. As will be observed, we offer but twenty of these farms—eight of 40 acres, eight of 80 acres, and four of 160 acres each, and the rule must necessarily be "first come first served." Therefore, those who intend to compete for these valuable premiums should begin at once.

Remember

that one of our beautiful chromos (as advertised in another place) is given to every subscriber.

Any further information concerning these premiums may be had by addressing

ORANGE JUDD COMPANY,
245 BROADWAY, NEW YORK.

FRAMES FOR THE CHROMOS.

We have made arrangements to supply frames to our subscribers who may desire them for the Chromos which are now being distributed. Many will no doubt avail themselves of this opportunity to place these beautiful pictures in handsome frames at moderate cost. In all cases where sent by express, the purchaser will pay express charges. The prices of the frames are as follows:

**For American Agriculturist Chromo,
"UP FOR REPAIRS,"**

**Or for Hearth and Home Chromo,
"LOOK OUT!"**

Letter A. Neat Black-Walnut Frame, Gilt Band...	\$1.15
" B. Wider, " " " " " " " " " " " "	1.75
" C. Richer Style, Polished " " " " " " " " " "	2.75

Letter D. Full Gilt Frame, 2 inches wide.....	\$1.50
" E. " " " " 2 1/2 " " " " " " " " " "	2.00
" F. Belgian Gilt Frame 2 inches wide.....	2.50
" G. " " " Fluted 3 " " " " " " " " " "	4.00

**For American Agriculturist Chromo,
"MISCHIEF BREWING."**

No. 1. Neat Black-Walnut Frame, Gilt Band...	\$1.15
" 2. Wider, " " " " " " " " " " " "	1.75
" 3. Richer Style, Polished " " " " " " " " " "	2.75

No. 4. Full Gilt Frame, 2 inches wide.....	\$1.50
" 5. " " " " 2 1/2 " " " " " " " " " "	2.00
" 6. Belgian Gilt Frame, 2 inches wide.....	2.50
" 7. " " " Fluted 3 " " " " " " " " " "	4.00

**For Hearth and Home Chromo,
"THE STRAWBERRY GIRL."**

No. 8. Neat Black-Walnut Frame, Gilt Band...	\$1.40
" 9. Wider, " " " " " " " " " " " "	2.30
" 10. Richer Style, Polished " " " " " " " " " "	3.25

No. 11. Full Gilt Frame 2 inches wide.....	\$1.75
" 12. " " " " 2 1/2 " " " " " " " " " "	2.50
" 13. Belgian Gilt Frame, 2 inches wide.....	3.00
" 14. " " " Fluted 3 " " " " " " " " " "	5.00

Address orders, specifying by its letter or number the frame desired, and inclosing price, as above, to the

ORANGE JUDD COMPANY,
245 BROADWAY, NEW YORK.

BACK VOLUMES OF *American Agriculturist*, AND OF *Hearth and Home*.

The publishers of the *American Agriculturist* can supply any of the back volumes of that paper from the Sixteenth to the Thirty-second. These volumes contain more varied and interesting information on all matters pertaining to the Farm, Garden, and Household, than can be obtained in books costing three times as much money. Price of each bound volume, at the Office, \$2.00; sent post-paid, \$2.50.

The publishers can also supply the back volumes of their finely illustrated Weekly Journal, *Hearth and Home*, for the years 1869, '70, '71, '72, and '73. These volumes are neatly and uniformly bound in cloth, with title in gilt on back and side. With their beautiful engravings, and abundance of useful and entertaining reading, they will prove valuable additions to any library. Price of each bound volume, at the Office, \$4.00; if sent by express, the purchaser will pay express charges.

ORANGE JUDD COMPANY, 245 Broadway, New York.

THE BEST THINGS OUT FOR CHILDREN.



CRANDALL'S BLOCKS.

BEAUTIFUL,
AMUSING,
INSTRUCTIVE.

CRANDALL'S Building - Blocks.

Price—No. 1, \$2; No. 3, \$1; No. 4, \$1.

CRANDALL'S Masquerade - Blocks.

Price \$1.

CRANDALL'S Expression - Blocks.

Price 50 Cts.

Express charges, in all cases, to be paid by purchaser.

MANUFACTURED BY

C. M. CRANDALL & CO.

The Trade supplied on liberal terms.

ORANGE JUDD COMPANY,

Sole Agents,

245 BROADWAY, NEW YORK.

RICH FARMING LANDS

For Sale Very Cheap!

THE BEST INVESTMENT!

No Fluctuations! Always Improving in Value!

The WEALTH OF THE COUNTRY is made by the advance in REAL ESTATE.

NOW IS THE TIME!

Millions of acres of the finest lands on the Continent, in EASTERN NEBRASKA, now for sale—many of them never before in market—at prices that DEFY COMPETITION.

800,000 Acres Sold in Four Years!

83,000 Acres Sold in the Last Four Months!

The Rush of Immigration is to NEBRASKA!

FREE HOMES FOR EVERYBODY!

Five and Ten Years' Credit Given, with Interest at Six per Cent.

The Land Grant Bonds of the Company taken at par for lands that can now be purchased at a large discount. Full particulars given; new Guide with new Maps mailed free by addressing

O. F. DAVIS,
Land Commissioner U. P. R.R.,
OMAHA, NEB.

The Pulsometer or Magic Pump.



The simplest, most durable, and effective steam pump now in use. Adapted to all situations, and performs all the functions of a steam pump without its consequent wear and care. No machinery about it. Nothing to wear out. Will pump gritty or muddy water without wear or injury to its parts. It can not get out of order.

C. HENRY HALL & CO.,
20 Cortlandt Street, New York City.

Self-Propel-For Cripples

For In and

Can be EASILY one leaving the State your ease, for illustrated cut-styles and prices.

Please mention this paper.



ling Chairs and Invalids Ont Door Use.

propelled by any use of hands, and send stamp ular of different S. A. SMITH, 90 William St., N. Y. City.

W. A. COVERT & CO., Produce Commission Merchants, No. 68 Pearl Street, New York. Quick sales and prompt returns. Send for our weekly Prices-current and Marking Plate.

\$500 REWARD will be paid to any one who will inform of a business that pays well for the money invested, in a book well worth the \$1.25 WELLAUER. Send 10 cts. for Auger book. Address AUGER Co., St. Louis, Mo.

THE HOOSIER SCHOOL-MASTER.

By EDWARD EGGLESTON.

Finely Illustrated, with 12 Full-Page Engravings, and Numerous Other Cuts.

NOTICES BY THE PRESS.

It is full of quaint humor, a tender pathos, and vivid descriptions.—*New York Standard.*

The "events" are stirring and dramatic, and the style is quiet, impersonal, and almost epigrammatic in its ability to lay bare an entire situation or character in a sentence or phrase.—*Brooklyn Daily Eagle.*

It is at once quaint and truthful, and illustrated as it is by masterly cuts, it should be one of the most popular books.—*Christian Standard (Cincinnati).*

For realistic conception and life-like delineation of character, it is not excelled by any American story.—*Methodist.*

Some passages in it, for life-like delineation and the simple, artless beauty which constitute the highest perfection of story-writing, are equal to some of the very best passages in Dickens.—*Religious Telescope.*

PRICE, POST-PAID.....\$1.25.

ORANGE JUDD COMPANY,

245 BROADWAY, NEW YORK.

HO! FOR THE HOLIDAYS!

THE BECKWITH \$20 PORTABLE

FAMILY SEWING MACHINE.

Diploma awarded at the Great American Institute Fair, Nov. 15, 1873.

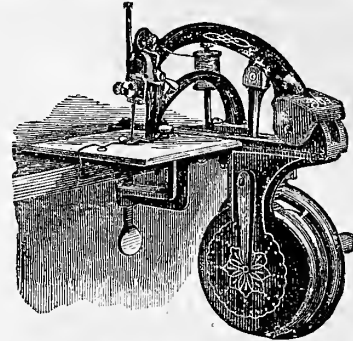

Hundreds of Letters from all quarters indorse the merits of our machine.

"Our four families, all having \$60 machines, all prefer the Beckwith."

See letter below.

BEAUTY, UTILITY, AND STRENGTH COMBINED.

WHAT A HOLIDAY PRESENT,

From Father or Brother,
For a Wife or a Daughter,
A Sister or Mother!

As we have fully expressed an opinion of its merits heretofore, we prefer to let our patrons speak, who are fully indorsing our highest expressions of this wonderful invention. The following will suffice as a specimen:

Office of "Rural Empire Club," J. W. Briggs, Proprietor, }
WEST MACEDON, N. Y., Oct. 29, 1873. }

BECKWITH SEWING MACHINE COMPANY:

Gents: The Machine has arrived, and has been the rounds and tested in our four families, where there are four \$60 machines; and all agree that The Beckwith is preferable to either, in several points. Please send me two books of instruction for working the machine. We had one, but it is mislaid or lost.

Yours truly,

J. W. BRIGGS, P. M.

Orders promptly filled on receipt of \$5; the balance, of \$15, on delivery by express.

BECKWITH SEWING MACHINE CO.,
862 Broadway, New York.

The End of the World.

A LOVE STORY.

By EDWARD EGGLESTON,

Author of "The Hoosier School-Master."

WITH

Thirty-two Fine Illustrations.

NOTICES BY THE PRESS.

The personages who figure in this story are, with one exception, country people—such men and women as Wordsworth loved to study. It is not every man, whatever may be his talents, that can safely enter this sphere of literary labor. To be successful in it, he must possess exceptional qualities; but for those who know how to find it, here there is gold of the purest, richest kind. In such a work, however, there is no convenient place where mediocrity can rest; there is nothing but absolute failure or absolute success. And Mr. Eggleston has succeeded. His power lies in the delineation of character. The plot is ingenious and natural, the incidents are managed with great skill, and there are many descriptive passages of singular force and beauty. But the strongest impression left on the reader's mind as he closes the volume is that he has been in the company of very interesting men and women, and has made a number of new and valuable acquaintances.—*The Albion, New York.*

Price, Post-paid, \$1.50.

ORANGE JUDD COMPANY,

245 BROADWAY, NEW YORK.

The Mystery

OF

Metropolisville,

By EDWARD EGGLESTON,

Author of "The Hoosier School-Master," "The End of the World," etc.

FINELY ILLUSTRATED.

CONTENTS.

Preface.—Words Beforehand. Chapter 1. The Autocrat of the Stage-Coach.—2. The Sod Tavern.—3. Land and Love.—4. Albert and Katy.—5. Corner-Lots.—6. Little Katy's Lover.—7. Catching and Getting Caught.—8. Isabel Marlay.—9. Lovers and Lovers.—10. Plausibly, Esq., takes a Fatherly Interest.—11. About Several Things.—12. An Adventure.—13. A Shelter.—14. The Inhabitant.—15. An Episode.—16. The Return.—17. Sawney and his Old Love.—18. A Collision.—19. Standing Guard in Vain.—20. Sawney and Westcott.—21. Rowing.—22. Sailing.—23. Sinking.—24. Drugging.—25. Afterwards.—26. The Mystery.—27. The Arrest.—28. The Tempter.—29. The Trial.—30. The Penitentiary.—31. Mr. Linton.—32. A Confession.—33. Death.—34. Mr. Linton's Courtship.—35. Unbarred.—36. Isabel.—37. The Last.—Words Afterwards.

ILLUSTRATIONS.—By FRANK BEARD.

His Unselfish Love found a Melancholy Recompense.—The Superior Being.—Mr. Minorkey and the Fat Gentleman.—Plausibly sells Lots.—"Py George! He! he! he!"—Mrs. Plausibly.—The Inhabitant.—A Pinch of Snuff.—Mrs. Ferrer.—One Savage Blow full in the Face.—"What on Airth's the Matter?"—The Editor of "The Windmill."—"Git up and Foller!"

Price Postpaid, - - - - \$1 50

ORANGE JUDD COMPANY,

245 BROADWAY, NEW YORK.

FEBRUARY, 1874.

AMERICAN

AGRICULTURIST

FOR THE FARM, GARDEN & HOUSEHOLD.



Vol. XXXIII

Number 2

PUBLISHED BY THE
ORANGE JUDD COMPANY

245 BROADWAY,

NEW YORK.

STANDARD WORKS ON HORSES.

Sent post-paid on receipt of price.

- Cole, S. W. The American Veterinarian. 18mo. \$ 75
- Dadd, Geo. H. The Modern Horse-Doctor; containing Practical Observations on the Causes, Nature, and Treatment of Disease and Lameness in Horses. 12mo. 1 50
- De Huys, Chas. The Percheron Horse. 12mo. Illustrated. 1 00
- Dwyer, Francis. On Seats and Saddles, Bits and Bitting, and the Prevention and Cure of Restiveness in Horses. 12mo. Illustrated. 2 60
- Frank Forester's Horse and Horsemanship of the United States and British Provinces of North America. By Henry William Herbert. In two superb royal octavo volumes of 1,200 pages, with steel engraved original portraits of thirty celebrated representative Horses. This Standard Historical Work has been thoroughly revised, newly written, compiled, and perfected to the present time. By S. D. & B. G. Bruce, Editors of the *Turf, Field, and Farm*. Price, post-paid. 10 00
- Herbert, H. W. (Frank Forester). Hints to Horse-Keepers. A Complete Manual for Horsemen; embracing how to Breed, Buy, Break, Use, Feed, Physic Horses, etc. Illustrated. 12mo. 1 75
- Jennings, R. Horse-Training made Easy. Being a New and Practical System of Teaching and Educating the Horse. 16mo. 1 25
- Jennings, R. The Horse and his Diseases; embracing his History and Varieties, Breeding, etc. Illustrated. 12mo. 1 75
- McClure, R. The Gentleman's Stable Guide. Familiar Descriptions of the Am. Stable; most approved Method of Feeding, Grooming, and General Management of Horses. 12mo. 1 50
- Mayhew, E. The Illustrated Horse Management. Containing Descriptive Remarks upon Anatomy, Medicine, Shoeing, Teeth, Food, etc. Illustrated. Svo. 3 00
- Mayhew, E. The Illustrated Horse Doctor. Being an Accurate and Detailed Account, accompanied by more than 400 Pictorial Representations, of the various Diseases to which the Horse is subject. Svo. 3 60
- Miles on the Horse's Foot. 75
- Murray, Rev. W. H. H. The Perfect Horse. 4 00
- Riley, H. The Mule. A Treatise on the Breeding, Training, and Uses to which he may be put. 12mo. Cloth. 1 50
- Simpson, J. C. Horse Portraiture; embracing Breeding, Rearing, and Training Trotters, their Management on Track, Preparation for Races, etc., etc. With an Appendix containing the performances of Dexter, and a Portrait. 2 50
- Stewart, John. The Stable Book. A Treatise on Management of Horses, in relation to Stabling, Feeding, Grooming, Watering, and Working; Construction of Stables, etc., etc. 12mo. Illustrated. 1 50
- Stonehenge on the Horse in the Stable and the Field. By J. H. Walsh (Stonehenge). Illustrated. 170 engravings. Svo. Cloth. 3 50
- Veterinary Homeopathic Practice. 5 00
- Wallace, J. H. American Stud-Book. Vol. I. Being a Compilation of the Pedigrees of American and Imported Blood-Horses to 1840. 10 00
- Wallace, J. H. American Trotting Register. Containing Pedigrees of Trotting Horses, and a Record of all Performances, from the earliest dates to the close of 1870; being over 6,000 contests. With Essay on True Origin of the American Trotter, and Rules of Government for trials of speed. 5 00
- Walsh, J. H. (Stonehenge). The Horse in the Stable and the Field, and Management in Health and Disease; with Essay on the American Trotting Horse; Suggestions on Breeding and Training of Trotters. Large 12mo. Illustrated. 2 50
- Warne's Handbook on the Horse; Varieties and Management. 50
- Woodruff, Hiram. The Trotting Horse of America. How to Train and Drive Him. 12mo. Cloth. 2 25
- Youatt, W. On the Structure and Diseases of the Horse, with their Remedies. Brought down by W. C. Spooner. 12mo. 1 50

Address ORANGE JUDD COMPANY, 245 BROADWAY, NEW YORK.

STANDARD WORKS ON Cattle, Sheep, and the Dog.

Sent post-paid on receipt of price.

- Allen, R. L. Domestic Animals. History and Description of the Horse, Mule, Cattle, Sheep, Swine, Poultry, and Farm Dogs. With Directions for their Management, Breeding, etc. 12mo. \$1 00
- Allen, L. F. American Cattle. Their History, Breeding, and Management. Illustrated. 12mo. 2 50
- Dadd, J. H. The American Cattle Doctor. Containing the Necessary Information for Curing the Diseases of Oxen, Cows, Sheep, etc. 12mo. 1 50
- Darwin, Charles. The Variation of Animals and Plants under Domestication. Illustrated. 2 vols. 12mo. 6 00
- Flint, Chas. L. Milch Cows and Dairy Farming. 2 50
- Guenon, M. F. A Treatise on Milch Cows, whereby the Quality and Quantity of Milk any Cow will give may be accurately determined by observing natural marks and external indications alone, etc. Svo. Cloth. 75
- Harris, Joseph. A Treatise on the Pig. Breeding, Rearing, Management, and Improvement. Illustrated. 1 50
- Jacques, The Barn-Yard. A Manual of Cattle, Horse, and Sheep Husbandry; or, How to Breed and Rear Domesticated Animals. 12mo. 1 00
- Jennings, R. Sheep, Swine, and Poultry. The best Modes of Breeding, their Feeding, Management, etc. Illustrated. 12mo. Cloth. 1 75
- Jennings, R. Cattle and their Diseases. Embracing their History and Breeds, Crossing and Breeding, Feeding and Management. 1 75
- Morrell, L. A. The American Shepherd. Being a History of the Sheep; with their Breeds, Management, and Diseases. 12mo. 1 75
- Randall, H. S. Fine Wool Sheep Husbandry. 12mo. 1 00
- Randall, H. S. Sheep Husbandry. With an Account of the Different Breeds, and Directions in regard to Summer and Winter Management. 1 50
- Randall, H. S. The Practical Shepherd. A Complete Treatise on the Breeding, Management, and Diseases of Sheep. Svo. 2 00
- Youatt, W., and W. C. L. Martin. Cattle. Being a Treatise on their Breeds, Management, and Diseases. Illustrated. 12mo. 1 50
- Youatt, W., and W. C. L. Martin. The Hog. A Treatise on the Breeds, Management, Feeding, and Medical Treatment of Swine, etc. 1 00
- Youatt, W. Sheep. Their Breeds, Management, and Diseases. To which are added Remarks on the Management of Sheep in the United States. 1 00
- Herbert, H. W. (Frank Forester). The Dog. By Dinks, Mayhew, and Hutchinson. Compiled, Edited, and Illustrated by Frank Forester. 3 00
- Richardson, H. D. Dogs. Their Origin and Varieties; Directions as to their Management, etc. 12mo. Cloth. 60
- Stonehenge on the Dog. 3 75
- Warne's Handbook on Cattle; Varieties and Management. 50
- Warne's Handbook on Sheep; Varieties and Management. 50
- Willard, A. A. Dairy Husbandry. 3 00
- Youatt, William. The Dog. Illustrations. Svo. Cloth. 4 00

Address

ORANGE JUDD COMPANY, 245 BROADWAY, NEW YORK.



GOOD WAGES

Can be made by men and women in all parts of the U. S., selling Wilson's Patent Hemstitching Worker, one of the most useful household inventions in the world. Sample worker by mail to those wishing the agency upon receipt of \$1, which retails quickly for \$2. Address E. M. HALL & CO., Manufacturers, 202 Broadway, New York, or 18 Clark Street, Chicago.

P. S.—"Every Lady should have one."—N. Y. Tribune.

THE SURGEON-GENERAL of the United States at Washington has arranged with the Elastic Truss Co., 683 Broadway, New York, to supply their admirable Truss as needed for pensioners, officers, soldiers, sailors, etc. The wretched metal springs, finger-pads, and iron hoops, and all the brood of torturing implements heretofore imposed upon a suffering and credulous public, are now absolutely abandoned by all but the less informed portion of the community. A few unprincipled dealers, unable longer to sell their horrible instruments of death, the spring Trusses, now steal the name "Elastic Truss," and try to sell their worthless "rupture belts" and bogus "Elastic" and "band" Trusses. The Elastic Truss Co. have 28 Branch Offices in the principal cities: 129 Tremont St., Boston; 1202 Chestnut St., Philadelphia; 255 Pennsylvania Av., Washington; 44 West 4th St., Cincinnati; 415 East Water St., Milwaukee, etc. Send for Circular.

W. A. COVERT & CO., Produce Commission Merchants, No. 68 Pearl Street, New York. "Quick sales and prompt returns." Send for our weekly Prices-current and Marking Plate.

INVENTORS Who wish to secure PATENTS should write to MUNN & CO., 27 Park Row, New York, for Advice and Pamphlet, 103 pages, FREE.

THE BEST THINGS OUT FOR CHILDREN.



CRANDALL'S BLOCKS.

BEAUTIFUL, AMUSING, INSTRUCTIVE.

CRANDALL'S Building-Blocks.

Price—No. 1, \$2; No. 3, \$1; No. 4, \$1.

CRANDALL'S Masquerade-Blocks.

Price \$1.

CRANDALL'S Expression-Blocks.

Price 50 Cts.

Express charges, in all cases, to be paid by purchaser.

MANUFACTURED BY

C. M. CRANDALL & CO.

The Trade supplied on liberal terms.

ORANGE JUDD COMPANY, Sole Agents, 245 BROADWAY, NEW YORK.

AMERICAN AGRICULTURIST

FOR THE

Farm, Garden, and Household.

"AGRICULTURE IS THE MOST HEALTHFUL, MOST USEFUL, AND MOST NOBLE EMPLOYMENT OF MAN."—WASHINGTON.

ORANGE JUDD COMPANY,
PUBLISHERS AND PROPRIETORS.
Office, 245 BROADWAY.

ESTABLISHED IN 1842.

Published also in German at \$1.50 a Year.

{ \$1.50 PER ANNUM, IN ADVANCE.
SINGLE NUMBER, 15 CENTS.
{ Copies for \$5; 10 for \$12; 20 or more, \$1 each.

Entered according to Act of Congress, in January, 1874, by the ORANGE JUDD COMPANY, at the Office of the Librarian of Congress, at Washington.

VOLUME XXXIII.—No. 2.

NEW YORK, FEBRUARY, 1874.

NEW SERIES—No. 325.



Contents for February, 1874.

Agassiz... Illustrated... 41
Agriculturist Strawberry... 64
Bee Notes for February... 49
Boys and Girls' Columns—Beautiful and Curious Stone—How Business is done under the Sea—“English Currants”—Aunt Sue's Puzzle-Box—Goats. 9 Illustrations... 67, 68
Books Noticed... 48
Calf-Feeder... Illustrated... 57
Catalogues received... 49
Cattle, Covered Stalls for... 3 Illustrations... 56
Cattle, Transportation of... 59
Cow, What may be Expected of a Jersey... 59
Currants, Cultivation of... 63
Dog, Shepherd... Illustrated... 60
Drain, Safety... Illustrated... 58
Duck, Imperial Pekin... 58
Eggs, Barly... 53
Evergreen, An Ornamental... 63
Fertilizers for Particular Plants, Special... 63
Fish in Small Ponds... 58
Flower Garden and Lawn for February... 44
Flowers, Blue Vervain... Illustrated... 64
Fruit Garden for February... 43
Fruit Growing in Utah... 63
Greenhouse and Window Plants for February... 44
Harrow, Square... Illustrated... 53
Horse, Morgan Abdallah... Illustrated... 53
Horse Trough, An Improved... Illustrated... 57
Horticultural Stealing... 61
Hot-Beds, Profit from... 49
Household Department—Supports for Shovel and Tongs—Home Topics—What Shall we Have for Breakfast?—Renovating Old Feathers—Cake-Making... 2 Illustrations... 65, 66
Kitchen Garden for February... 44
Lime, Burning Shells to Make... Illustrated... 57
Market Report for February... 44
Notes from the Pines—Balance of Things—Exotic Aquatic Plants—Fish—Winter-Blooming Pelargoniums—Double Chinese Primrose—Propagating Echeverias... 62, 63
Ogden Farm Papers, No. 48—Water—Jersey Cattle—Feeding Clover—Dairy Statistics—Food for Cattle—Laborers—Butter—Soiling Crops... 50, 52
Orchard and Nursery for February... 43
Pca, Japan... Illustrated... 63
Saw, Protection for a Circular... Illustrated... 57
Sheep, A New Method of Hurdling... Illustrated... 55
Sheep, Shropshire-Down... Illustrated... 53
Stock, Watering in Winter... 50
Turkeys, Loss of Weight in Dressing... 59
Verbena, The Garden... Illustrated... 61
Walks and Talks on the Farm, No. 122—Cellars Freezing—Corn—Farming—Money—Wages—Potatoes... 54, 55
Work, Hints about... 42

INDEX TO "BASKET," OR SHORTER ARTICLES.
American Dairymen's Ass. 47
Boat Building... 47
Bones, Grinding... 48
Book by Prof. Winchell... 48
"Brahma Fowl," L. 48
Wright's... 46
Butter Packages... 47
Castor Beans and Oil... 47
Cattle, Soiling... 47
Chips and Bark, Value of... 48
Clevis, Three-Horse... 48
Cochins, Buff... 75
Coll. For a Jumping... 75
Concrete Buildings... 75
Congress to do, Three... 47
Things for... 48
Co-operative Store... 75
Corn, Broom... 46
Corn, Harrowing... 75
Cow, Worms in a... 75
Cyclopedia, American... 46
Darnel... 75
Death of Henry A. Decker... 45
Diseased Udder... 75
Drains and Irrigating... 48
Pipes for... 75
Emigration to Kansas... 48
Farmers' Club, Volinia... 75
Fence Posts, Improving... 47
Fertilizers, Artificial... 46
Floriculture, Henderson's... 46
Practical... 46
Florida Agriculturist... 47
Forestry, Memorial... 47
Fowls' Legs, Disease in... 75
Gail Borden... 47
Gardeners' Monthly... 46
Goats for Milk... 75
Grass, Italian Rye... 48
Grass, Sowing in Spring... 47
Hay, Measure for... 75
Hog Cholera... 47
Horses Hanging Back... 48
Humbugs, Sundry... 45
Kansas Homesteader... 47
Ladder, How to Carry a... 47
Land Sales... 47
Lard Oil... 47
Leather and Tanners' 48
Fleshings... 75
Leather Scraps, Value of... 47
Manure for Potatoes... 47
Mich. Agricultural College... 46
Milk, Temperature for... 47
Setting... 48
Mutton in Parvo... 75
Oleo Margarine... 75
Orchard, Crop for... 75
Ox, Heavy... 75
Patrons of Industry... 47
Plaster, Nova Scotia... 47
Poitou Ass... 75
Postal Cards, Use of... 45
Potato Disease... 75
Potato Premiums, Liberal... 47
Potato Planter... 47
Poultry for Profit... 75
Railroad, Burlington and... 45
Missouri... 75
Roofing Material... 48
Scratches... 75
Seeds, Agricultural Dep't... 47
Sheep Farming in Texas... 75
Sheep, Foot and Mouth... 47
Disease in... 75
Sheep in South Carolina... 48
Sheep on Shares, Caring... 47
Spinning Wheel, New... 48
Steaming Feed... 48
Stove, Vapor... 47
West, Going... 48
What we Call Mean... 46
Wheat, Harrowing... 48
Wheat, Head of Spring... 47
Whicler's Anti Snow-ball... 47
Ingr Pad... 47
Windmill... 75
Woolen Mill Refuse... 47

Calendar for February.

Table with columns for Day of Month, Day of Week, and Sun rises/sets, Moon rises/sets for Boston, N. York, Wash'n, and Chicago.

PHASES OF THE MOON.

Table showing Moon phases (Full, 3d Quart, New, 1st Quart) for Boston, N. York, Wash'n, and Chicago.

AMERICAN AGRICULTURIST.

NEW YORK, FEBRUARY, 1874.

One more month and spring will be here. It is a good thing to look forward. A farmer lives largely in the future. In the calf he sees the ripe steer. His plans are far-reaching, and require months and years for their perfect development. A man who can not wait with patience will not be a happy farmer. He must work and hope. We have had much to discourage us, but our prospects are now decidedly brighter. For two or three years past we have seen hard times. Wages have been high and prices low. Our expenses have been out of all proportion to our receipts. The "panic" of last September was the effect and not the cause of the general agricultural distress. As we have repeatedly stated, farmers for two or three years past have not been getting adequate compensation for their labor and capital. Many a farmer of skill, experience, and intelligence has received less pay for his labor than the average mechanic, or even, in some cases, than the unskilled laborer on our railroads and public works. The cities and villages seemed to be prospering, while farmers found it difficult to raise money to pay taxes and grocery bills. It needed the panic to convince our bankers, manufacturers, business, commercial, and railroad men that the nation could not prosper when corn was used for fuel, and when the money got for a hog would hardly buy a pair of children's boots. It was well that they should know that a farmer who had to pay \$3 or \$4 per day and board to get men to help him bind a crop of wheat that only yielded eight bushels per acre was not likely to buy many silk dresses or railroad bonds. And so the collapse came.

Now things are changed. Farmers, like all other classes, suffered by the panic, but we shall lose nothing by it in the end.

Favored by low prices, our exports of farm produce have been enormous. It is a good thing to get rid of our surplus. It will give us better prices for what we have left. To-day there is nothing in the prospect ahead that should discourage a good farmer. It seems brighter to us than at any time for several years past. Wages will come down, implements, machines, dry-goods, and groceries will be sold at reasonable rates. What we have to

sell will be higher; what we need to buy will be lower—in fact, is lower already.

But let it not be forgotten that to the poor farmer times are always hard. We must raise good crops and produce good beef, mutton, pork, cheese, butter, and fruit before we have any right to expect good times. It would be a sad thing for the country to have prices so high that a poor farmer who raises only ten bushels of wheat per acre on the average could get rich. The writer is a farmer, and all his interests and sympathies are with the farmer, but we can not but feel that many of our troubles are due to ourselves. We need, it may be, an "elastic currency," cheap freights, and fewer middlemen, more sheep and fewer dogs, a better Department of Agriculture, more farmers' clubs, more agricultural books and papers, and more farmers in Congress—but above all we need a better system of farming. Nothing will help us unless we help ourselves. We must farm better or quit the business. We must raise as much wheat, barley, oats, corn, beans, peas, and potatoes as we do now, but we must raise them on less land. We can not afford to spread our labor over three acres of land to raise 250 bushels of potatoes, when we can raise the same amount on one acre. And so with all the other crops. We shall never make money by farming until we aim to raise large crops per acre. Half our troubles come from spreading our labor over too much land.

Hints about Work.

On our own farm the most important labor of the winter is feeding stock and making manure.

Good Manure can only be made from good food. The more nitrogen the food contains the richer and more valuable will be the manure.

Oil-Cake, either from linseed or cotton-seed, makes the richest manure. Malt-combs, beans, and peas come next, and are nearly as good. Next come bran and clover hay. Then oats, Indian-corn, and barley; then timothy hay and corn-stalks. Bean and pea straw come next; then oat-straw, wheat-straw, and lastly barley straw.

Bran or Shorts is a favorite food with us. We feed it largely to sheep, store pigs, cows, and horses. We can sell timothy hay for \$28 per ton and huy shorts for \$18 per ton. And the manure from a ton of bran we estimate to be worth \$15, while that from a ton of timothy hay or corn is worth less than \$7, and that from a ton of clover hay about \$10, and from a ton of straw \$2.50 to \$3.

Straw and Stalks are scarce and high. We run them all through a cutting box, both for food and for litter. When cut up, straw will absorb much more liquid, and is consequently more valuable for bedding than long straw.

Corn-Meal for Manure has been much talked about lately. We recommend it heartily—but it should first be passed through some animal machine, such as a cow, horse, sheep, or pig.

For Store Animals, half a pound of corn-meal per day for each 100 pounds of live weight, mixed with two pounds of chaffed straw or stalks is, with us, an economical food.

For Fattening Animals, three-fourths to one pound of meal per day to each 100 pounds of live weight is about the proper quantity.

Three Good Plans for Managing Manure are: 1st, to draw it out every day and spread it on the land, or put it in a large pile in the field where it is to be used; 2d, to let it fall into a manure cellar; 3d, to wheel it out every day, or as often as convenient, to some central spot in the barn-yard and make it into a heap. The latter is our own plan.

No Plan can be Worse than leaving the cow manure in a scattered heap just outside the cow stable, and the horse manure in another heap, and the pig manure, half mud and corn-cobs, in another heap, where it freezes solid. Mix the whole in a compact heap, and it will ferment all winter and be ready for use in the spring.

A few Planks are Needed on which to wheel the

manure on to the heap. Without these the work can not be economically performed.

Any Work, that can be done now instead of in the spring should not be neglected.

Seed Corn, if not already selected, should be attended to.

Clean Seed barley, oats, peas, beans, and spring wheat, and put in barrels, bins, or bags ready for use. Blow out all light grains and foul stuff.

Sort over Potatoes in the cellar, and free the cellar from all decaying vegetables and fruit.

Ventilate the Cellar every day by opening the door and windows when the temperature is above freezing or not more than a degree or two below.

Whitewash the cellar walls and also the walls and partitions of pig-pens, cow-stables, hen-house, etc.

Clean and Oil the Harness, and let it be put in thorough repair.

Make an Inventory of everything you have on the farm, and its estimated value.

Petroleum is very cheap. We wish we could induce every reader of the *Agriculturist* to get a barrel and use it freely for preserving implements, machines, etc. In cold weather it is better to warm it before using, as wood will absorb more of it.

Examine every Implement and Machine you have; clean it; oil the bolts and tighten the nuts, and put it in perfect order. Then wash it with petroleum. Go over it two or three times and get on as much as the wood will absorb.

Get out Stone-boat and other planks. Repair old stone-boats and make new ones. Saturate them with petroleum. A farmer would find a stone-boat for every team very useful. For ordinary use two-inch plank is thick enough; but for large stones better have them 2½ or 3 inches thick.

Mend Bags, mark them, number them, and put them in their proper place. A piece of board say three feet long and six inches wide nailed on to one of the beams in the barn makes a convenient support for bags—and for many other things, such as pails, baskets, etc.

A Good Farmer can not enjoy his evenings or sleep well at night until he knows that all his animals are comfortable and everything is in its proper place.

An Hour's Work at Night in the winter season will often save two hours' work in the morning when everything is frozen up solid or is covered with snow.

Make the House Warm and Comfortable.—Provide proper ventilation, and make the doors and windows air-tight.

Horses that are working regularly need extra feed in cold weather. There is nothing better than chaffed hay and corn-meal.

Horses that are Driven Fast should have oats instead of corn-meal.

Farm Horses that are doing little or nothing can be well wintered on chaffed straw with a little corn-meal and bran, say 2 bushels chaff (16 lbs.), 4 lbs. bran, and 4 lbs. corn-meal each per day.

Cows are healthier in a deep, open shed than in a close, ill-ventilated stable. But a stable is much more economical of space, and it can be kept warm, clean, and well ventilated; and when this is the case the cows will require less food, or if they eat as much food will either give more milk or store up fat.

Liberal Feeding is usually the most economical feeding. It is a great waste of digestive powers to so feed a cow that she neither gives milk nor increases in weight; it is a still greater waste to so feed her that she must consume more or less of the fat and flesh previously stored up in the system. This is what happens when an animal weighs less in the spring than in the fall.

Cows that are well fed and kept in a barn stable should be carded with a curry-comb two or three times a week. It will pay in health, in looks, and in milk.

Watering Cows is an important matter. We for-

merly turned our cows out to water only once a day, but are now satisfied that it is better to turn them out twice a day. Be careful, too, that each cow has access to the trough, and that the "boss cows" do not keep the others away. Cows require much more time in watering than horses. Encourage them to drink by throwing a little meal on the water.

Salting Animals requires judgment. To let them go without for several weeks and then give them all they will eat is a bad practice, and sometimes a dangerous one. The better plan is to have rock-salt where the animals can lick it every day.

In Fattening Animals, the great aim of the feeder is to induce them to eat all they can digest and assimilate. How this can be best done depends on circumstances. Change of food will sometimes be attended with advantage and sometimes not. There is one general rule that should be borne in mind: When the animal is hungry, in the morning, feed the less palatable food, such as straw or stalks, and when the animal has eaten as much as it will then tempt it to eat more by giving more cut straw or stalks moistened and mixed with bran and meal. The food left in the mangers may be sprinkled with salt and water and put in racks in the yard, and when the cows are turned out to water they will be likely to eat it up clean.

Sheep are specially fond of clover hay. They will keep in good condition on this alone. But when straw is fed grain should be given in addition, say one pound each per day. We are now feeding our sheep (Cotswolds) twice a day chaffed oat and pea straw, all they will eat, ½ lb. bran, and ¼ lb. oats or peas, and 15 bushels of sliced mangels to 100 sheep. We feed mangels only once a day, at noon. We never had them do better. Merinos of course, being so much smaller, require less food.

When to Feed will depend a good deal on circumstances. Horses and cows should be fed early in the morning, say six o'clock. Sheep need not be fed until after breakfast, say seven or eight o'clock, and then again at four o'clock in the afternoon. They do not like to eat in the dark, unless it is a little in the middle of the night.

Swine, owing to low prices, have been much neglected. It is a good time to engage in raising improved breeds of pigs. The demand is now good, and is likely to be still better. Pork has advanced rapidly, and the prospects are favorable for a still further advance. Get a good breed, and give good care and feed, and pigs will be as profitable as any stock we can raise.

Work in the Horticultural Departments.

This month will witness the commencement of active garden operations in many localities. Nothing will so facilitate the work as to keep ahead of it, and even drive it; the moment our work begins to drive us, so soon do we find gardening, as well as other occupations, up-hill business. Now is the time to arrange all the necessary operations, so that the labors of the year may be carried on economically and intelligently. Every gardener ought to know at the commencement of each week what work is to be done; in this arrangement due allowance must be made for rainy days, and in-doors work provided for the help whenever it is possible. Order at once everything that can possibly be needed during the busy season. Seeds, trees, etc., if left until wanted, will in many instances be of inferior quality, as late in the season the stock of the best varieties is exhausted. A workshop in connection with a garden is almost a necessity, as many handy tools can be made during the winter and rainy weather.

Orchard and Nursery.

Much can now be done towards making the orchard look well during the summer.

Washing and Scraping can be carried on when mild days occur. A triangular plate of iron attached to a handle three feet in length makes a

handy implement for removing the loose bark from trees; the edges should be sharpened, but not enough to injure the fresh bark. The best material for washing after the trees have been scraped, is strong, soft soap thinned with water, so as to be conveniently applied by a brush; a solution of potash or soda will answer, but soap is better.

Manure.—Draw out at any time when convenient; it is better for the teams to have something to do during the winter. If left in piles of sufficient size in the field, fermentation will go on, except when the weather is very cold. See that plenty of absorbents are used in the stables; dry earth and leaves are the best materials for this.

Planting.—The time for planting must be governed, of course, by the locality; in the Northern states two months hence will be soon enough, while at the South a great deal will be done the present month. Nothing is gained by too early planting; better wait until the ground is thoroughly dry, as the trees cannot be injured if properly heeled-in in a dry spot.

Varieties must be selected according as they are intended for market or home use. Spring is the time for tree agents and peddlers to make their annual trips through the country. Do not buy from their showy colored pictures unless the varieties are known to be good, and even then it is a better plan to visit a neighboring nursery if there is such in the vicinity, where the varieties are kept true to name. There are agents who are undoubtedly honest in their dealings, but there are so many of the other sort that it is hardly safe to trust to them unless they are personally known.

Insects.—A constant fight must be kept up upon the various insects which infest the orchard and nursery. Tent caterpillars' eggs are easily seen now, and can be more readily removed than if left until they hatch. The female canker-worm will appear on mild days, and ascend the trees to deposit her eggs. There are many patents for preventing the ascent, but anything fastened around the tree which will serve as a barrier, will be effective, whether strips of paper covered with tar or printer's ink, or troughs containing petroleum.

Injured Trees must be looked after, and any limbs which have been broken by wind or ice removed, after which let the wound be carefully smoothed with a sharp knife, and covered with liquid grafting-wax, shellac varnish, or common paint. If any trees have been girdled by mice, the bark may be united by small twigs of the same kind placed at short distances around the trunk, so that the inner bark of the tree is brought in contact with the inner bark of the twigs, both at the top and bottom. Then a plaster of cow dung and loamy earth should be applied, and the whole bandaged with a cloth.

Cions.—Cut before the sap starts, and preserve in fresh sawdust or sand.

Grafting should be done only when the swelling buds show that growth has commenced. In many parts of the South this process can be carried on now, but the middle of April or first of May is early enough for most Northern localities.

Fruit Garden.

But little can be done here until later in the season.

Dwarf Trees may be pruned and afterwards washed with soft soap, as suggested under "Orchard and Nursery." The pruning can usually be done with a sharp knife if they have not been neglected too long. The principal pruning necessary will be to bring the trees into proper shape.

Grape-vines.—Prune during mild days, if not attended to in the fall.

Blackberries and Raspberries.—Set as soon as the condition of the soil will allow, as the underground shoots start early, and are often injured if their removal is left until late. Provide stakes or wire trellises for tying up the canes.

Currants and Gooseberries.—Cut out the old growth and shorten the new so that plenty of light

and air may be had to insure the proper ripening of the fruit growing in the centre of the bushes.

Trellises for grape and other vines will be needed, and they may be made during stormy weather.

Posts should be cut and prepared for use in and around the garden; locust and red cedar make the most durable.

Kitchen Garden.

Every one who has a piece of ground, even though it be only a city lot, can have a constant supply of some of the choicer vegetables if a little effort is made in this direction. Most persons would be surprised to know the quantity of vegetables which market gardeners grow upon their small plots, and though it is not expected that all will do as well, yet on a very small area properly cared for, a great many of the garden luxuries could be grown. Lettuce, cucumbers, radish, tomatoes, egg-plants, etc., are a few of the things which are raised easily. At the South cabbage, lettuce, onions, parsnips, beets, etc., may be sown at any time during the month. The tenderer varieties, however, must not be put in until settled warm weather.

Manure is one of the necessities of the gardener as well as the farmer, for without it no adequate returns can be had. Every precaution then should be used to preserve and increase the quantity. With a little care the amount may be increased very largely. Absorbents should be used in the poultry-yards, around the stables, and in the pig-pen. If the manure-pile is turned occasionally, and the house slops poured over it, fermentation will be more active, and the pile better rotted, and consequently more useful for the immediate needs of the crops. Save the horse manure in a separate pile, where it can be easily got at when wanted for making hot-beds.

Straw Mats.—During cold and stormy days, when there is no chance for out-of-doors work, make a supply of straw mats for covering frames and hot-beds, to protect plants from too much sun and from frost. Use rye straw, making the mats 7 feet long and 4 1/2 feet wide, so that two will cover three sashes. The best plan is to take five strands of tarred twine the proper length, then lay the straw on an inch thick, placing the butt ends towards the edge of the mats. After this, take five other strands and lay them directly over the first ones, and with a needle and twine sew through the straw, taking care that the loop catches both strings. When the whole is completed, the edges of the straw can be cut straight, and the mat is ready for use. Always store in a dry place under cover when not in use.

Cold Frames will need considerable attention now to supply plenty of air. Remove the sashes entirely when the weather will allow.

Hot-beds will not be needed except by market gardeners before another month, unless very early vegetables are wanted. Shelter should be provided at the side from which the prevailing winds come to keep the wind from blowing directly upon beds.

Brush and Poles for peas and beans should be cut early, trimmed and sharpened; place near where they are to be used.

Root Crops left in the ground during winter may be dug as soon as the ground will allow.

Rhubarb.—Apply a thick dressing of fermenting manure to the bed to induce an early start. A few roots for forcing may be taken up and removed to a hot-bed, and supplied with plenty of fermenting manure.

Flower Garden and Lawn.

The beauty of a flower garden consists in having a different arrangement of plants each year. Where the same varieties are planted year after year, with no change in the grouping, a garden soon loses its attractiveness. With a little forethought this difficulty can be done away with.

Lawns.—Roll as soon as the frost is out of the ground, and if not top-dressed last fall apply a compost of fine manure or bone-dust and ashes.

Plants in Pits or Cellars.—Give air every warm

day, or else they will become sickly and drawn, now that the sun is more powerful. Water only when the soil looks dry.

Dahlias and other roots stored in cellars must be looked after, to see that they do not rot from too much dampness. If any signs of mould or rot occur remove to a dry room.

Shrubs.—Prune and thin when the weather is mild enough. Cut back those varieties which flower on the new growth to proper shape. Where the flower buds are already formed only the crowded growth should be cut out.

Rustic Work.—Give a coat of petroleum to protect from the weather. Make any new trellises or rustic work needed now in order to have everything ready for use as soon as required.

Walks.—Clear up all rubbish which has accumulated and roll when the frost is out.

Greenhouse and Window Plants.

Care must be used with the fires, as during mild weather they are apt to be neglected, and a sudden change may cause a great deal of damage. Never let the fire go entirely out; if very warm a few cinders or ashes placed on the fire will prevent its burning rapidly.

Camellias and Azaleas coming into flower require more heat and water. Never sprinkle the plants when in bloom, as the water injures the flowers.

Window Plants will need showering to remove the dust; some of the plants with thick leaves can have the dust removed with a sponge.

Bulbs.—Continue to bring these from the cellar to keep up a succession. As fast as the flowers fade remove the flower stalks and gradually dry off. Those flowered in glasses are not worth keeping, as several years are needed before they will recover from the effects of forcing.

Propagation.—Plants needed for sale or planting in the flower garden and borders may be propagated this month. The temperature of the air of the propagating house should always be lower than that under the cutting bench. This is usually effected by means of boards arranged so as to confine the heat under the benches.

Annuals.—Sow a few boxes for early flowers, and for planting out.

Re-pot such plants as have filled the pots with roots, and all intended for specimen plants.

Climbers.—Tie these up to wires; climbers will serve a good purpose for shade for other plants. Passion-flowers, wax-plants, roses, etc., are all very good for greenhouse use, as they are of easy culture.

Insects.—Fumigate often to kill the green-fly. The plants should be thoroughly syringed the morning after smoking.

Forcing.—Deutzia gracilis, and Astilbe Japonica are good plants for forcing. They should be brought into heat early this month.

Commercial Matters—Market Prices.

The following condensed, comprehensive tables, carefully prepared specially for the American Agriculturist, from our daily record during the year, show at a glance the transactions for the month ending Jan. 13th, 1874, and for the corresponding month last year, also for the year ending Dec. 31, 1873:

Table with 5 columns: RECEIPTS, SALES, TRANSACTIONS AT THE NEW YORK MARKETS. Columns include Flour, Wheat, Corn, Rye, Barley, Oats. Rows show monthly and yearly data for 1874 and 1873.

4. Receipts at head of tide-water at Albany each season to Nov. 30th.

Table with 6 columns: Flour, Wheat, Corn, Rye, Barley, Oats. Rows show monthly receipts for 1873, 1872, 1871, 1870, 1869, 1868.

5. Receipts of Breadstuffs in New York in each of the last six years:

Table with 6 columns: Flour, Wheat, Corn, Rye, Barley, Oats. Rows show monthly receipts for 1873, 1872, 1871, 1870, 1869, 1868.

6. Exports from New York, Jan. 1 to Dec. 31:

Table with 6 columns: Flour, Wheat, Corn, Rye, Barley, Oats. Rows show monthly exports for 1873, 1872, 1871, 1870, 1869, 1868.

7. Comparative Stock of Flour in New York, Jan. 1:

Table with 4 columns: 1871, 1872, 1873, 1874. Rows show Western and State Flour, Canada Flour, Southern Flour, California Flour, Grand total.

8. Comparative Stock of Grain in New York, Jan. 1:

Table with 4 columns: 1871, 1872, 1873, 1874. Rows show Wheat, Corn, Rye, Barley, Oats, Malt, Peas.

CURRENT WHOLESALE PRICES.

Large table with multiple columns: PRICE OF GOLD, FLOUR, WHEAT, CORN, RYE, BARLEY, OATS, etc. Includes prices for various grades and types of goods.

Gold has been up to 112 1/2 closing January 13th at 111 1/2 as against 109 1/2 on December 12th. The dealings in most kinds of Produce have been on a more liberal scale since our last, and the prospect at the close is much more encouraging for mercantile interests generally. There has been an active trade in Flour, especially in shipping and trade extras, at improved prices. Wheat has been in much better request, chiefly for export, advanced rates, but closed tamer, and 3c. @ 6c.

bushel off highest figures for Spring. Corn has been offered very sparingly, and with a brisk inquiry, largely speculative, has been quoted decidedly dearer. Oats and Barley have also been actively sought after, and prices have favored sellers, closing buoyantly. Provisions have attracted more attention, but closed quiet and somewhat unsettled. Cotton has been selling freely at buoyant rates. Wool has been in more request at improved prices, closing firmly. Hops, Hay, Straw, and Tobacco have been selling moderately, on a general steady basis as to values. Seeds have been quoted higher, with a readier market noted, particularly for prime Clover for export purposes.

New York Live-Stock Markets.

RECEIPTS.						
WEEK ENDING	Bees.	Cows.	Calves.	Sheep.	Swine.	Total.
December 15.....	7,433	69	628	23,073	42,332	73,533
December 22.....	7,796	61	670	25,061	40,838	74,416
December 29.....	5,914	51	676	18,178	35,764	60,583
January 5.....	7,247	61	614	16,909	22,735	47,566
January 12.....	6,829	63	652	17,875	30,333	55,707
Total for 5 Weeks.....	35,219	310	3,238	101,096	171,942	311,805
do. for prev. 4 Weeks.....	226,032	311	4,514	93,697	215,911	387,545
Bees.						
Average per Week.....	Cows.	Calves.	Sheep.	Swine.		
do. do. last Month.....	6,513	78	62	617	20,219	34,338
do. do. prev's Month.....	6,159	74	74	1,136	22,674	58,985
				74	1,716	30,337

Bees.—The irregular receipts of last month have created a somewhat irregular market, and prices have changed up or down with less or greater supply. The year's business closed up with receipts of 442,744 head, against 425,375 head for 1873 and 380,934 for 1871. The closing prices of 1873 were fully 1½c. to 2c. lower than a year previous, and premium cattle dragged at the price of extra, bringing 13½c. against 15½c. a year ago. During the last month the prices have been maintained only by moderate supply, and gave way whenever the supply equaled the demand. Prices may be marked down fully ½c. during the month; choice steers selling at the close at 12¼c. @ 12½c. @ 13c. @ 14c.; first quality steers at 11½c. @ 12c.; native cattle, oxen, and cows, 9c. @ 11¼c.; and Texans at 7½c. @ 10½c.

Prices for the past five weeks were:

WEEK ENDING	Range.	Large Sales.	Aver.
December 15....	7 @ 13½c.	10½ @ 11¼c.	10¾c.
December 22....	7 @ 13½c.	10 @ 11c.	10½c.
December 29....	7½ @ 13½c.	10½ @ 11¼c.	10¾c.
January 5.....	7½ @ 13c.	10 @ 11c.	10½c.
January 12.....	7½ @ 12½c.	10 @ 11c.	10½c.

Milk Cows.—There has been fair inquiry for good cows, with light supply, and prices have remained steady. \$90 was paid for an extra cow and calf, but the range has been from \$40 to \$80 for cow and calf. **Calves.**—For this stock we have no change to remark; the supply has fallen off since last month nearly one-half, yet there has been no advance in prices to notice. Fair milk-fed calves sold at the close for 8c. @ 11c. @ 12c., and grassers at \$6 @ \$12 @ head. Hog-dressed calves are arriving and selling at 10c. @ 13c. for milk and 5c. @ 9c. for grass and fed. **Sheep and Lambs.**—The arrivals are below the average, and, with good demand, the quotations are advanced somewhat, but the market is dull. Prices at the close reached 5½c. @ 7½c. @ 8c. for ordinary stock; 7½c. @ 7½c. for selected; and 8c. for fancy Canada wethers. **Swine.**—Prices have again advanced, with continued light receipts, although the market has been constantly dull. Live hogs were quoted nominally, without sales, at the close of the week at 5½c. @ 5½c. @ 6c. Dressed hogs were moving uneasily in an unsettled market at 6½c. @ 6½c. for Western, and 6½c. @ 7½c. for City.



containing a great variety of items, including many good hints and suggestions which we throw into smaller type and condensed form, for want of space elsewhere.

Remitting Money:—Checks on New York City Banks or Bankers are best for large sums; make payable to the order of Orange Judd Company. Post-Office Money Orders for \$50 or less, are cheap and safe also. When these are not obtainable, register letters, affixing stamps for postage and registry; put in the money and seal the letter in the presence of the postmaster, and take his receipt for it. Money sent in the above three methods is safe against loss.

Postage: On *American Agriculturist*, 12 cents a year, and on *Hearth and Home*, 20 cents a year, in advance. Double rates if not paid in advance at the office where the papers are received. For subscribers in British America, the postage, as above, must be sent to this office, with the subscription, for prepayment here. Also 20 cents for delivery of *Hearth and Home* and 12 cents for delivery of *American Agriculturist* in New York City.

Bound Copies of Volume Thirty-two are now ready. Price, \$2, at our office; or \$2.50 each, if sent by mail. Any of the last seventeen volumes (16 to 32) will also be forwarded at same price. Sets of numbers sent to our office will be neatly bound in our regular style, at 75 cents per vol. (50 cents extra, if returned by mail.) Missing numbers supplied at 12 cents each.

Clubs can at any time be increased by remitting for each addition the price paid by the original members; or a small club may be increased to a larger one; thus; a person having sent 10 subscribers and \$12, may afterward send 10 more subscribers with only \$3; making a club of 20 at \$1 each; and so of the other club rates.

Our Fine Chromos.—Read all about them on third cover page. It is easy to secure one or both.

FREE.—Fine Gold Pens, with Silver Cases—The Best Silver-plated Table Articles—Table Cutlery—Children's Carriages and Toys—Floral Sets—Garden Seeds and Flower Bulbs—Sewing Machines—Washing Machines and Wringers—Pocket Knives—Fine Gold and Silver Watches—Melodeons—Pianos—Guns and Rifles—Cultivators—Books—etc., etc.; all these are among the valuable articles to be found in the Premium List for 1874 on page 73. Any person can, with a little effort, secure one or more of these valuable articles. Thousands have done it. There is room for thousands more. It is very easy to obtain clubs of subscribers for the two popular papers, the *American Agriculturist* and *HEARTH AND HOME*. Try it.

See Pages 73 and 74.

Take Both Papers.—If both the *American Agriculturist* and *HEARTH AND HOME* are taken together they may be had for only \$4, and \$4.50 pays for both papers and a Chromo with each.

The German Agriculturist is published at the same price as the English edition, and is mainly a reproduction of that paper, with a special department edited by the Hon. F. Münch. Will our readers kindly mention this to their German friends? Perhaps some who employ Germans as gardeners, laborers, etc., would be glad to supply them with useful reading matter by subscribing for the German edition for them.

Farms for Premiums.—A most liberal offer of farm lands as Special Premiums is made by the Publishers to those who will secure clubs of subscribers for the *American Agriculturist* and *HEARTH AND HOME*. See particulars on fourth cover page of this paper.

Henry A. Dreer.—The announcement of the death of this most estimable man came upon his friends with a startling suddenness. He died at his residence near Philadelphia on the 21st of December last of a disease of the heart. Mr. Dreer was one of the leading seedsmen of the country, and at the same time an enthusiastic lover and cultivator of plants. He was an influential member of the Pennsylvania Horticultural Society, and as he was also eminently a working member, his helpful presence will be sadly missed by that body. Of a singularly even and genial temperament, he made hosts of friends, and his strict integrity secured him the esteem of all who had business relations with him. We learn that the business will be continued under the same name by Mr. Dreer's son, Wm. F. Dreer, and his nephew, Wm. H. Smith, who have been associated with him for several years.

The Use of Postal Cards.—The Russian who when he first saw a pair of snufflers thought them very handy, as he illustrated by snuffing the candle with his fingers and putting the snuff into the snufflers, has passed into history. He is rivalled in a degree by the American who found postal cards a great convenience, as he had only to write his message on it, put it into an envelope and send it off without any trouble. We have a correspondent who excels both in ingenuity. He encloses us six postal cards with a distinct question upon each, and asks us to answer "through the *Agriculturist*." To make the matter sure he scratches out his address from his letter and fails to put it on the cards.

SUNDRY HUMBUGS.—A gentleman in Philadelphia incloses us a circular of the Louisville, Ky., Library Lottery, and asks us if it is a humbug. It is probably no more so than any other lottery. We hold that

ALL LOTTERIES ARE HUMBUGS,

no matter how fairly managed. Their main object is to make money for their proprietors, and the pretense of benefiting some public or charitable institution is a mere bait. Within the recollection of many, lotteries were tolerated, and even legalized, in almost every state in the Union, but of late years the moral sense of the community has demanded that they be suppressed, and now most states have laws prohibiting them. Take this Louisville affair, for instance, which seems to be profitable, or it would not be kept up so long; we showed a year ago, in a quotation from a Louisville paper, that the purchasers of tickets paid nine dollars to put one dollar into the library fund. Then here is the Gift Concert for the Reform School of Leavenworth, Kansas, which we have already noticed, and which is mainly a plan to help the projector to sell his house at a good price, that being one of the prizes. Even Utah has gone into the lottery business, and proposes a "Gift Concert" for the benefit of a free school in the city of Corinne. No matter under what pretense these things are advertised—and we consider those cloaked under charitable disguises more reprehensible than bold and barefaced lotteries—they all hold out temptations, that the few may get something at the expense of the many. It is gambling in its meanest form; and no honorable man, whether he be governor, mayor, merchant, or priest, should allow his name to be used to promote any such scheme.

THE \$4 GENEVA WATCH

dealers have received a check. We have long had them in our list of humbugs, but now the law has interfered with their little game. The watches were advertised by J. Wright & Co., 609 Broadway, but the Post-office authorities found that letters thus directed were received by one Robinson at 599 Broadway, and that the real place of business—if business it could be called—was at 49 Amity street. Here the letters were opened, the money taken out, and a circular dispatched informing the sender of the money that his order would be filled in turn. Robinson has been arrested and bailed in \$35,000, to appear for trial upon the charge of getting letters from the mail under false pretenses.

DANGEROUS BURNING FLUIDS.

We have before set forth the dangerous character of several of the articles offered as cheap illuminators. That these will give an excellent light and at a low cost, we do not doubt; but we feel it a duty to warn all our readers not to use benzine, naphtha, gasoline, or any of these light oils in any form; no matter how compounded or mixed up, they are dangerous in themselves and dangerous in all their compounds. Nothing is safer than gunpowder in the hands of an old hunter, because he knows its danger; but he would not trust his children with it. These articles will not themselves explode, and those who sell them convince the ignorant that they are safe by showing that they will extinguish a lighted match. But the trouble is with the vapor which they give off at ordinary temperatures, and this, when mixed with air, is highly explosive and dangerous. No liquid is safe to burn that gives off a vapor that will flash at a lower temperature than 110°.... "I. I. A." sends us a circular of a "Chemical Fluid Gas Light," and asks our opinion, but as he does not send the formula, we can only say that, from the circular, we infer it is no gas at all, but merely a contrivance for burning the vapor of some highly volatile and consequently dangerous liquid.

DUBIOUS CASES

are more numerous this month than usual. We have a pile of circulars, in some of which goods are offered at remarkably low prices, generally requiring \$5 to be sent with the order. In others all sorts of knickknacks are offered for sale by agents who are requested to send a sum to procure an outfit, and others offer to sell at a very low rate the secret of making wonderful perfumes, medicines to cure various diseases, hair restorers, and the like. While it is probable that any one who invests in any of these enterprises will regret it, we can not show that the proprietors will not do as they agree to, and we are not warranted in setting them down by name as humbugs. We have complaints against one of these concerns from persons who write us that they have sent money to one of these "companies" and got no return. Not finding the name in the directory, we sent one of our associates to the place advertised, who found the "company" in an obscure upper room, with samples of the goods they send out, and several persons busy in preparing circulars for the mail.... After all that has been said upon the matter, we can not feel a great deal of pity for persons who send money to unknown parties and receive no returns. People should recollect that no really good article is ever

sold in New York or anywhere else for much less than it is worth, and that whoever offers articles for half their usual price or less, either came by them dishonestly, the articles are not what they are represented to be, or they are offered as a bait to cover some ulterior design.

MEDICAL HUMBUGS.

"P. M.," of Greencastle, Ind., finds fault because we do not show up Ayer, of Lowell, and several others in our humbug column. While we do not approve of the manner in which Mr. Ayer introduces his medicines, he does not keep the composition of them a secret, but publishes the formula; and as we have no doubt that he furnishes precisely what he agrees to, we can not class his medicines among the humbugs. There are a great many proprietary medicines sold which are in themselves good and useful. The objection to them is that they tempt people to medicate themselves and to dose themselves when no medicine is needed. We therefore think that, so far as this goes, such medicines are to be discountenanced; but they stand upon a different footing from those sent out by the miserable quacks who promise everything and give a useless or worse than useless stuff.

EYE-CUPS AGAIN.

Of all the special organs by which the brain receives impressions from the outside world, none is so wonderful in its structure or so delicate and so sensitive as the eye. When it is deranged it requires the greatest skill to ascertain what the trouble is and to properly restore it to usefulness. The sellers of these eye-cups themselves claim that they do only one thing—restore the lost convexity of the eye. It is a box-wood or other cup to put over the eye, to which an india-rubber bag is attached. By squeezing the bag and placing the cup over the eye, a pressure from within, outward, is created, which these people claim will restore the proper shape. Now, but very few of the derangements of the eye are due to any disturbance of the shape. Some are, but there is not the slightest reason to believe that these eye-cups will help them. It is astonishing that people who would not think they knew enough to repair a broken coffee-mill will tinker with their own eyes. We have the highest authority in the country for saying that these eye-cups are wrong in principle and mischievous in practice.

THE NATIONAL SURGICAL INSTITUTE

is on its travels. It has been to California, and we have a show-bill announcing that it will be at Salt Lake City and Denver on certain days. This circular—we beg pardon, "journal"—is a curiosity, and quite beats one of Barnum's circus bills. Two large pages are used to show all possible human deformities, with the poor creatures in every possible kind of harness. The contrasted figures of patients as received and as dismissed beat the writing masters' specimens of the chirography of pupils before and after taking lessons. The array of deformed and ulcerated feet and limbs is repulsive beyond description. These institute people claim to be M. D.'s. The more shame for them. These

"INSTITUTES AND UNIVERSITIES"

are great things. We have several of them in New York. Sometimes one man calls himself a university or an institute, and then it happens, though rarely, that one of these quack chaps really does get, by some hocus-pocus, a charter from the legislature. One of these lovely concerns is the

CLINTON MEDICAL AND SURGICAL INSTITUTE,

which is run by one James Bryan. This Bryan obtained a charter in which are mentioned as incorporators Dr. John Harvey, Dr. Robert Bell, Prof. Wm. Draper, and others. It will be noticed that these are names well known in the medical world, and are chosen with great ingenuity. Mr. Bryan has been summoned by the attorney general of the state of New York to show cause why his charter should not be forfeited, as these incorporators can not be found, and it is charged that no such persons exist. If the charter should not be forfeited on this account, it should for the vile character of the publications of the "Institute." We have before us a small volume entitled, "Things You Ought to Know," made up of essays by associates of Bryan and aliases, which is about as vile as anything among the many vile publications that have fallen into our hands. Each essay is followed by advertisements of certain remedies, or that of the "Institute." Madame Lucille Demarre's discourses of "Marriage Socially Considered," and follows it with an advertisement of her "Eau d'Amour," or "Perfume of Love," which is a most remarkable smell, as we read: "With this celebrated article as a helper, no young gentleman or lady need pine in single blessedness. With its help they can win the unchanging affection of whom they please, and marry happily and speedily, if so desired." Then comes "Prof. W. Draper, M.D.," with his "Philosophy of Marriage," with advertisements to match. This "Professor" advertises,

among other things, the "Cordial of Venns," the uses of which a regard for decency prevents us from stating. "Dr. John Harvey" writes about a "Womanhood," and advertises, from this very "Institute," female pills, the real object of which is more thinly disguised than usual. There are other things offered in this vile work of which virtuous people do not know, and which it would hardly be proper to name. This Bryan, with his male and female associates or aliases, whichever they may be, is properly under the eye of the authorities. His case should induce the legislature to be careful to whom they grant charters, for more vile and pernicious quackery never existed than is practiced by this chartered "Institute."

COUNTERFEIT MONEY.

For the first time in many months we have only one new name as a dealer in "Queer." This is sent by a correspondent in Kansas, who proposes to write to the chap and have us meet his appointment with an officer. This would not be of the slightest use. The man could not be arrested unless he passed or sold counterfeit money, or had it in his possession. It is not probable that any of these chaps make or have any counterfeit money—they are quite too sharp for that. Their object is to get a victim into their hands; they make a bargain with him, get his good money, and put a parcel of paper into his hands which turns out to be no counterfeit money at all. The victim does not dare to "squawk," for he has already made himself a party to a criminal transaction, and he can not make a complaint without admitting that he was ready to go into the counterfeit money business. If any get caught in this trap they are rightly served. The real dealers in counterfeit money are not such fools as to write letters and send out circulars. These chaps who pretend to do it know that the cupidity of some will lead them into their trap, and when once in, their fears will keep them quiet. Some interesting cases are now in the hands of the courts, and when they come to trial we may expect some developments that will be worth noticing in our "Humbug" column.

Broom Corn.—"R. F. S.," Beech Grove, Ind. It is no more trouble to raise broom corn than ordinary field corn. The cultivation is the same, and the harvesting and drying is no more trouble, if so much, as husking and cribbing corn. The best variety is the Missouri evergreen, and the method of cultivation and preparation is described in the *Agriculturist* of May, 1873. A little pamphlet has been written upon this subject by R. A. Traver, of Charleston, Illinois, which contains much valuable information.

Artificial Fertilizers.—"D. H.," Burlington, Ct. The labor of making composts of artificial fertilizers and loam will hardly pay. The composting may be done far cheaper by spreading the fertilizer upon the soil and mixing it with a light harrowing. For sown crops the seed and fertilizer should be harrowed in together. Superphosphate very often fails of any noticeable effect when used upon soils containing lime. The acid or soluble phosphate forms an insoluble compound with the lime. This is what is termed "going back," and suffices to explain many disappointments. Muck is best composted with lime, or, better still, used as an absorbent in the stables and yards.

L. Wright's "Brahma Fowl."

"F. W. B.," New Haven, Ct. This little work is a "true account" of the Brahma fowl, its origin, its character, its habits, its value, and the best method of breeding to preserve all its excellences up to the proper standard. It is equally devoted to the light and dark Brahmas, is handsomely illustrated, and is sold for \$2.50.

See Pages 73 and 74.

The American Cyclopædia.—Appleton's Cyclopædia is one of the most important works ever issued from the American press. The first edition, which was completed in 1863, found a place in every considerable library; indeed it was a respectable library in itself. The publishers are now bringing out a new edition, which like the former will be comprised in 16 volumes. It is, like the first edition, under the editorial charge of Messrs. George Ripley and Charles A. Dana. All the articles are thoroughly revised and mostly rewritten, with many new ones added, so that though the plan is the same it is essentially a new work. The first four volumes which we have received show a great improvement in the mechanical appearance of the work, and illustrations and maps are introduced where the subject requires them. There is no work of its kind so valuable to the American reader as this, as it gives special prominence to American matters, and biographical sketches of prominent persons still living. The various topics are treated by eminent specialists, and in a popular and at-

tractive style. As far as we have examined the work it appears to be still more valuable than the first edition. Although this edition has been announced, but a short time, we learn that the sales have been very large.

Henderson's Practical Floriculture.

—This work has had a large sale for one of its kind, and deservedly so, as it is the only one in the language which gives plainly and without any reservation the practices and processes of those who grow plants as a business and avail themselves of every economical and labor-saving expedient. There are some florists who keep their operations a secret; that this is bad policy is shown by the course of Mr. Henderson, who has always freely communicated the "secrets" of his business in his articles to the *Agriculturist* and other papers, and especially in his books. Instead of injuring his business by telling others how they can go and do likewise, he has constantly increased it. He feels, as every florist should, that next to the pleasure of discovering a "new wrinkle" is the telling of it for the benefit of others. A new and much enlarged edition of "Henderson's Practical Floriculture" has just been issued by the Orange Judd Company. This, while it is a work indispensable to those who raise plants for sale, contains much that is given for the special benefit of the amateur cultivator. Though the number of pages is considerably greater than the old edition, the price remains the same as before, \$1.50.

What we Call Mean.—

That the publishers of papers should have been, in common with other business men, embarrassed by the late panic is not surprising, and we consider it essentially mean that when one of our agricultural cotemporaries was pinched more closely than was pleasant, some other agricultural papers took special pains to give publicity to the matter, not only by comments of their own but by quoting items in relation to it from other papers. A fair rivalry we believe in, but to endeavor to turn the misfortunes of another to one's own benefit is a meanness of which we are sorry to say some journals have been guilty. If the publisher in question had failed to fulfil his agreements with his subscribers that would have been another matter, but so long as his paper was furnished as good and as regularly as ever we can not see whose business it is to interfere in the matter.

The Gardener's Monthly opens the

year with a number of unusual variety and interest. The editor gives Recollections of Travel, which being an account of a journey made last summer, lacks the freshness of the rest of the number. It is so seldom we catch our friend Meehan napping (even Jove nodded though) that we like to pick him up when he gives us a chance. In speaking of the route between Texas and the Indian territory he says, "The line was very gay with the large brush-like heads of *Cenotaura Americana*, a beautiful annual which it is surprising has not yet got into cultivation." This plant, the common name for which is American Star-Thistle, we grew a dozen or more years ago, and the seeds are to be found in the catalogues of all the principal seedsmen, those of Philadelphia included. If our friend had studied his *Agriculturist* with the care that becomes every one, especially horticultural editors, who wishes to know what is going on, he would have learned that a new variety of this Star-Thistle was introduced into England last year.

The Michigan Agricultural Col-

lege.—The New York Evening Post says: "It is proposed to make daily manual labor compulsory upon the students at the Michigan Agricultural College, and some of the kid-gloved young farmers protest."—Manual labor has always been required of the students, except in case of sickness or disability, and the young men at the college, while they can no doubt wear kid gloves as well as any other gentlemen should the occasion demand it, are as hard-working a set of young farmers as can be found anywhere. But this is about as near to the facts as the daily papers get when they meddle with agricultural matters.

Wool.—

During all the fluctuations of value consequent upon the recent financial crisis, now happily in a great measure passed over, the market value of wool remained almost constant. "Domestic fleece" was quoted in the New York market on September 10th at 48 cents per pound; exactly the same quotation was current on November 29th, while almost all other staples except grain, cotton amongst the rest, had greatly declined. The fact that wool, wheat, corn, and oats thus retained their value amidst the most unfavorable circumstances goes to show that agriculture is the most stable of all the industries, and while all else may be going to wreck the farmer alone can afford to contemplate the disaster with comparative serenity.

A Kansas Homesteader.—Abraham Difenbaugh, Hutchinson, Reno Co., Kansas, settled upon 160 acres of land four miles from that town in April, 1872. He is a miller, and was unacquainted with farming; his success therefore is the more encouraging. He broke up the first season 100 acres, and put part in sod corn which did well. The remainder of the season was occupied in building and planting trees. The past season (1873) he had 80 acres of corn which produced 40 bushels per acre; 4 acres of wheat produced 80 bushels; and 10 acres of oats produced 450 bushels, which were sold for 30 cents a bushel. Wheat brought \$1 a bushel. Potatoes, cabbages, tomatoes, melons, and pumpkins, yielded very largely. He has sown 45 acres of fall wheat this season, which looks splendid. He has 200 apple trees and 25 cherry and peach trees, all doing well. All the work above mentioned has been done by himself and his son, a boy of eleven years, and the expenditure of \$40 in money. Mr. Difenbaugh kindly offers to give any advice or information to those who write to him for that purpose. Persons thus writing should, of course, inclose a stamped envelope for reply.

Land Sales.—The Atchison, Topeka, and Santa Fe Railroad Co. have sold from April, 1873, to October, 87,963 acres of land, at an average price of \$5.50 per acre. For October last the sales were 23,676 acres.

Soiling Cattle.—“H. D.,” Shipley, Ohio. There is no more economical mode of feeding cows for the dairy than soiling; that is, growing crops to be fed in the stable, the cows to be not pastured but exercised in a small yard daily. By this system, one cow can easily be fed the year round from the product of one acre of rich soil, and the manure saved is equal, including the litter, to one load per head per month. “Quincy upon Soiling Cattle,” price \$1.25, to be had at this office, is the best work upon this subject.

Wheeler's Anti Snow-balling Pad.—“I. B. S.,” Napanock, N. Y. This pad is an entire preventive of the gathering of snow-balls in the horse-shoe. It can be affixed by any person without the aid of a blacksmith, and we can confidently recommend it from personal experience with it during a whole winter.

Gail Borden died in Texas on January 11th, at the age of 72. His was a very varied and useful life. He was a settler in Texas before its independence, resided at the North for several years later in life, and again went to Texas, where he was actively engaged in developing the resources of the country when he died. He is best known to the public as the inventor of meat biscuit, condensed milk, condensed beef, etc. Through these inventions he had a handsome income, which he freely used for benevolent objects. Personally, Mr. Borden was a most genial old man, and his too rare visits to our office were always productive of pleasure.

“H. S. D.,” Thompsonville, Pa. We wrote a reply to your inquiry, and when about to address the letter found you had not given your name. We have frequently given notice that those who do not give us full name and address need not expect a reply in the paper. More comply with our regulations than we can find room to answer, and those who do not observe our repeatedly published terms can not expect to have preference over those who do. As this was a merely personal matter, we took the trouble to write an answer by mail, and do not find it pleasant to know that our time has been wasted.

See Page 75 for other “Basket” items.

Patrons of Industry.—This appears to be a weak imitation of the Patrons of Husbandry, the constitution and forms belonging to that order being mainly copied. Its ostensible object is to unite mechanics and laboring men in a body like that of the Patrons of Husbandry, but its real object seems to be to transfer money from the pockets of those who earn it to those of people who live by their wits. The headquarters is advertised as being in New York, but we have not yet seen any one who has succeeded in finding the head men. It looks like a concern that will do no harm if let alone.

The American Dairymen's Association.—The annual convention of this association was held at Utica, N. Y., on the 13th, 14th, and 15th of January. Although not so numerously attended as in some previous years, there was no lack of interest exhibited, and the papers read were of more than usual excellence. Amongst the more important of these were a paper upon “Butter Making,” by O. S. Bliss, of Vermont; one upon “Making and Marketing Butter,” by L. T. Hawley, of Syracuse; one upon “Experiments in Cheese Making,” by Mr. Green, of Pennsylvania; an-

other by X. A. Willard upon “Dairying in the West and South-west,” with others of equal interest to dairymen. The discussions elicited by the reading of these papers were eminently practical, and were made in a vigorous and lively manner. We regret that our space is too limited to do more than mention the bare fact of the meeting of this important convention, and would inform our readers that the papers at full length will be published by the association, and may be procured of the secretary, L. B. Arnold, of Rochester, N. Y., for 75 cents for the volume.

Forestry Memorial.—A committee appointed by the Farmers' Club, of the American Institute, have drawn up a memorial asking Congress to pass laws to preserve our present forests from destruction, as well as to encourage the planting of trees where none exist. Some of the things it asks of Congress are all right and proper, while others are not especially useful, such as asking it to publish the literature of Forestry in the form of public documents. There are no works so difficult to be obtained by those who need them as those published by Congress. Public documents always go where they are not wanted and seldom where they are; and we know of no way by which to thoroughly bury a work on Forestry or any other subject than to have it sent to the public printer—unless it may be to have it read before the Farmers' Club. Mr. George May Powell is the principal mover in this matter, and is, as we understand, a gentleman who has devoted much attention to the forests of this and other countries. He will be wise if he acts by himself, as he can accomplish much more than with such a load as the Farmers' Club to carry.

How to Carry a Ladder.—“E. W.,” Elwood, describes how Farmer W. carried home a long ladder which he had borrowed, and which was supposed to require four men to carry it. He balanced the ladder upon his wheelbarrow and lashed the sides of it to the handles of the barrow; then taking the end of the ladder, he wheeled it along with comparative ease.

Improving Fence Posts.—“R. McC.,” Although we can not say from personal experience, yet we have no doubt that fence posts would be made more durable by thorough soaking in lime water. It is the alumen of the timber which soon decays and causes the timber to rot, and the effect of lime is to solidify the alumen and render it insoluble. This effect would be produced upon fence posts as well as upon boards or planks, but the exposure of the posts to the lime would need to be for a longer period than that for thin boards.

Butter Packages.—“M. A. H.,” Dover, N. J. We have on previous occasions referred to the great need of small packages for butter, which would hold such quantities as would be sufficient for the week's consumption of a family, say two to five pounds. Here is a great field for the exercise of ingenuity, and the inventor of an acceptable package of such a shape that several of them could be packed into one larger one would certainly meet with much profitable encouragement.

Hog Cholera.—“A Kansas Farmer,” Linn Co., Kansas, says he has cured hog cholera by sprinkling fine lime-dust around his hog pens and upon the corn fed to the hogs.

Potato Planter.—“C. P. K.,” Northport, L. I. There is a machine which makes the furrow, cuts, drops and covers the seed, known as True's potato planter. The manufacturer of these machines will probably make his address known in the usual way before the season for using them arrives.

Castor Beans and Oil.—“J. M. M.,” Emporia, Kansas. The culture of castor beans is the same as that needed for corn. In harvesting it is necessary to gather the beans before they are ripe, and spread them upon a smoothly swept piece of ground surrounded by a board fence to prevent the beans from flying when the pods burst open. In making the oil the beans are ground into a paste, which is put into hair cloth bags and pressed beneath strong screws or wedges. The first oil is known as “cold drawn.” The cake is then pressed between heated plates and yields an inferior second product. There are several mills in St. Louis where the oil is manufactured. The refuse is a valuable fertilizer, but is of no value for food; it is in fact injurious to cattle.

Lard Oil.—“J. S.,” Logansport, Ind. The apparatus required is so expensive and cumbersome that a farmer could not make his own oil except at great cost.

A Fine Head of Spring Wheat.—A correspondent of the *American Agriculturist* at Fidalgo Islands, Washington Territory, sends us a head of Aus-

tralian spring wheat. “Please count the grains,” he writes, “and see if it will yield as many grains as the head of Diehl wheat which John Johnston sent to ‘Walks and Talks.’ I counted the grains in two heads, one had 103 and the other 126. I think the heads will average 75 to 80 grains. The wheat was raised on this Island.” The head sent us was remarkably handsome. There was nothing abnormal about it, as is sometimes the case with a very large head of Diehl. We counted the kernels in the head, and found 96. The grains were large and plump, and nearly as white as an average sample of Diehl. We should be glad to know the yield per acre, time of sowing, harvesting, etc. We may add that the head of Diehl raised by Mr. Johnston contained 65 kernels; those alluded to by “Walks and Talks,” one 80 kernels and the other 88 kernels.

Manure for Potatoes.—“Hartford.” Potatoes succeed best with thoroughly rotted manure in which no more fermentation can take place. A very excellent compost for potatoes is swamp muck, bone-dust, and plaster. One load of muck, 100 pounds of fine bone-dust, and a bushel (80 lbs) of plaster make a very useful fertilizer when stable manure can not be procured. Fish guano makes a good substitute for the bone.

Value of Leather Scraps.—“Concord,” Winterset, Iowa. Leather scraps are a very valuable fertilizer. The best way to utilize them that we have discovered is to bake them in an oven until they become quite brittle, and then to pound them with a wooden stamper or a flail upon a barn floor. In this way any waste leather may be made useful. They furnish an acceptable fertilizer for grape-vines, and may be hoed in around the roots.

Sowing Grass in Spring.—“Chasseur,” Washington, D. C. If a crop of rye is an object, and the land is not desired to lie idle a whole year, which would probably be injudicious anyhow, spring rye might be sown, and timothy and clover be sown with it. The rye and grass seed should be sown as early as possible. At least two bushels of spring rye should be sown, as it does not tiller or spread at the root like fall rye.

Nova Scotia Plaster.—“J. C.,” Pittston, Pa. Nova Scotia plaster is regularly imported into New York, where just now it is quoted in the market reports at about \$4 per ton.

The Florida Agriculturist is the name of the first agricultural paper ever issued in Florida. It is a weekly of eight pages, published at Jacksonville by C. H. Walton & Co., and edited by S. D. Wilcox. Its first number is bright mechanically and editorially, and looks as if it would deserve the success we wish it.

A Vapor Stove has been advertised, and several have written to ask us if it is a humbug. It is not a humbug in so far as it is just what it pretends to be, a stove in which the heating material is the vapor of naphtha. We would not advise any one to use naphtha as a heating or illuminating material, as it is not a safe thing to have in the house.

Woolen Mill Refuse.—“H. P.,” Hawthorne, N. J. The refuse from woolen mills is rich in nitrogen, and is a valuable fertilizer. As it is free from water, it is more valuable on that account. It generally sells for \$10 a ton or thereabouts.

Agricultural Department Seeds.—“E. R. S.,” Greenbrier Co., W. Va. The seeds distributed by the agricultural department are said to contain pestiferous weeds and insects—at least it is so charged by many Western people who have been gratuitously favored with them.

Boat Building.—“H. W. H.,” Hillsboro, Ill. Full directions with engravings for building boats and skiffs were given in the *Agriculturist* of August, 1871, and October, 1872. These numbers can be procured for 15 cents each.

Liberal Potato Premiums.—Messrs. B. K. Bliss & Sons, encouraged by the great interest excited by the potato premiums offered by them last year, offer this year the handsome amount of \$1,500 in equal sums for Brownell's Beauty, Early Vermont, and Compton's Surprise. Six prizes from \$100 to \$10 are offered for the greatest yield from one pound of seed of each kind, and similar sums for the largest quantity grown upon a quarter of an acre of ground. Some growers who obtained large results last year failed to receive a prize for the reason that they did not comply with all the conditions of the offer. Those intending to compete should send to Messrs. Bliss for a copy of the schedule for 1874.

Do Not Fail to Read It.—The Premium List on page 73 of this paper is worthy of the attention of everybody who would like to *do good* and at the same time *make money*. Thousands of persons in years past, not only in all parts of this country, but also in British America and in other parts of the world, have each obtained one or more of these valuable premium articles by simply collecting a list of subscribers and forwarding them, with their subscriptions, to the publishers. Do not fail to read the Premium List.

Italian Rye Grass.—"J. S. W.," Los Angeles, Cal. The seed of Italian rye grass may be procured of any of the principal seedsmen in New York. The price is about \$1 per bushel. No other grass does so well for irrigated pastures or may be cut so many times in one season.

Sheep in South Carolina.—"G. H. McM.," Winnsboro, S. C., says: In January, 1866, a planter of Fairfield county bought thirty-eight sheep which he turned into his pasture, and soon after bought a Bakewell ram, and afterward a Merino and then a South-down ram. This was the total of his purchases. He now (November, 1873), has 350 sheep worth \$1,000. His wool has netted him \$900, and his mutton has netted \$875, besides what his family consumed, and mutton has been their only meat during summer and fall of every year. No care was taken of the sheep except to salt them and to give them a little cotton seed in the winter. The manure, with very little effort to save it, has enriched thirty acres of land so that it now averages 1,000 pounds seed cotton per acre instead of 200 pounds previously. The sheep have a little more than doubled in number each year except this year. This exception is caused by the fact that 100 of the flock strayed off last December, and when found late in January they had lost all their lambs but 16. The experience of this gentleman proves that sheep would be very profitable in the South with careful management. The profit would arise not alone from the mutton and wool, but in supplanting commercial fertilizers on all lands lying at a distance from railroads.

Three-Horse Clevis.—"Z. H. M.," Richmond, Ind. It is impossible for us to say why manufacturers of implements do not advertise their wares. There is a three-horse clevis made which was figured in the *Agriculturist* some years ago, but which is patented; we do not know the manufacturers' address. Seeing the demand for such a clevis it would seem a judicious thing in the manufacturers to make their address known.

Horses Hanging Back.—"B. C." It depends altogether upon the shape of the double tree whether the horse which hangs back does the same work as the one ahead, or more work or less. It may very easily be that he does more work instead of less. The proper method is to keep the horses even in the traces and then both work alike. Bad driving or bad matching is usually the cause of the horse hanging back.

A New Spinning-Wheel.—"W. W.," Bellville, Mich. We can not say anything about the "Briec" spinning-wheel, not being acquainted with it. The spinning-wheel is not at all out of date; it is one of those aids to a domestic manufacture which may very profitably find a place in the farmer's home along with the knitting machine or the sewing machine, and furnish useful employment to his daughters, who ought not to be above adopting the industries which used to occupy their mothers and grandmothers. Every article of domestic use that can be made at home saves so much expenditure of money.

Value of Chips and Bark.—"G. S. N.," Moon, Pa. The chips and bark which accumulate around a saw-mill if partly rotted are valuable when plowed into the soil. We have found such matter a nuisance when spread upon grass land, but when spread thickly upon an orchard in which a crop of potatoes was planted, the potatoes were thickest and largest where there were the most chips. For use upon grass land we would spread the stuff out to dry partly and then rake it into heaps and burn it to ashes, spreading them upon the surface. In this way it would be very valuable, and if from hard wood would pay to haul it.

Harrowing Wheat.—"E. B.," Washington Co., Pa. It would not be always safe to harrow wheat amongst which timothy seed has been sown. Clover seed may be sown after the snow has disappeared and when the ground is full of small cracks made by a light frost. The seed will fall into these cracks, and as the soil thaws it will be covered up lightly.

Temperature for Setting Milk.—"A Subscriber," Decatur, Nebraska. Although the temperature of a spring may be 50° yet it may be so managed that the temperature of the milk set in it may be kept at about 60°. This is the best temperature for raising the cream as well as for keeping it. The supply of water should be so regulated as to keep the milk at 60°. At 50° the cream will rise more slowly than at the higher temperature, and the butter will neither be so good in flavor nor color. A good plan of regulating the supply of water would be to bring it in a small pipe into the reservoir, through which it passes in a gentle current, keeping the temperature about 60° to 62°.

Steaming Feed.—"A. S. T.," Howard Center, Pa. There is no better steam chest known to us than that figured in the *Agriculturist* of January, 1873. The best boiler is either a "steamer," of which there are several very useful kinds, or an engine boiler. A sheet-iron bottomed plank steamer is not safe or economical in space or fuel. It is better to build the steam room at a distance of at least 100 feet from the barn, and carry the steam in a cast iron pipe or boxed wooden logs made very tight at the joints. A wooden trough can not be made tight enough for economy. For pigs the method of cooking described in the *Agriculturist* of January, 1874, is the cheapest and easiest.

Roofing Material.—"J. E. B.," Graniteville, Ill. Where pine shingles can be procured for \$4 per M. they are certainly the best and cheapest roof possible excepting perhaps slates. Other roofing materials are intended as substitutes for shingles or for roofs of low pitch, in which cases they become the best material.

Book by Prof. Winchell.—"Anna L. J." The work you probably refer to is Winchell's "Sketches of Creation," price \$2.

Caring for Sheep on Shares.—"A. S. T.," Howard County, Pa. For a hilly, exposed country where the feed is good, our native sheep crossed with the Cotswold would produce a superior race, probably better than any other cross, the Cotswold being hardy and used to a hilly country. The usual terms for caring for a flock of sheep is half the net increase, losses being made up, and half the wool.

Grinding Bones.—"J. S.," Ithaca, N. Y. The grinding of bones requires very strong machinery and considerable power. The attrition consequent upon putting them inside of a revolving iron cylinder would certainly eventually reduce them to powder, but the process would be exceedingly slow and costly, and practically impossible. A good bone-mill is the only profitable method of reducing them to powder or fragments.

Three Things for Congress to do.—If the members of congress are wise they will see the cloud that is now much larger than several men's hands, and shape their course accordingly. It is a safe prediction that in the next congress the agricultural portion of the country will be more largely represented than ever before, if indeed it be not the controlling element. If the present congress wishes to be in favor with the people we can suggest three minor things which will tend to that end. 1st. So amend or reenact, or somehow fix the present postal law so far as it relates to the sending of seeds, plants, and the like, that no "rulings" of the department or perversity of individual postmasters will practically deprive the people of the benefits of the law. 2d. To abolish the duties on all plants and trees and arrange for their rapid passage through the custom-house. As matters now are three fourths of the plants are lost by the delays at the custom-house, and the present arrangement amounts to prohibition to all save dealers. For instance, the writer had sent him a box of mainly wild plants from England. The contents were appraised at \$70 in gold, when in fact they had no commercial value whatever, not a florist in the country would have given \$5 for the lot. Still they were appraised by some one who probably never before saw or heard of a single plant in the lot at \$70, and we were charged 20 per cent in gold on that sum. In another instance a friend in France sent us a box of canna roots which were delayed so long that every root died and yet the charges were \$11. We give these bits of personal experience as illustrations of matters concerning which we have frequent complaint. A friend in Illinois had cuttings sent him of all the willows in the royal gardens at Kew. These were given by the British government, and the introduction of some of them may be of great benefit to the country, especially to the West, yet our friend had to pay over \$20 for the privilege of getting them into the country. Our 3d item is the Department of Agriculture, which is in many respects a fraud and a nuisance. Some of the papers are for economizing by cutting it off altogether.

We do not agree with these. We insist that the department has not yet had a fair chance. In the first place needs a head, and in the second place ample funds for an intelligent head to carry out the most liberal plans without interference by congressmen in demanding places for friends or seeds for their constituents. If a fair trial of the department under these conditions is without beneficial results then it will be time to shut up shop. The congressmen who will start and push through these and other reforms having a direct bearing upon the agricultural community will be wise.

Emigration to Kansas.—The statement to which a correspondent alludes, to the effect that "hundreds of emigrants were returning from along the line of the Atchison, Topeka and Santa Fe Railroad in the Arkansas valley of Kansas, disappointed with the country," was published in a Western paper as he states. In the next issue of that paper the statement was circumstantially denied, with an apologetic explanation. We are the more concerned with this matter because of the report made by one of the editors of the *Agriculturist* in which this district was favorably spoken of. Realizing at the time the responsibility attaching to such a report, made more for the interest of our readers and the public than for any other reason, it was made only after thorough personal examination and deliberate judgment. It would be well for those interested to procure a copy of the whole report, which they may do by applying to Mr. A. E. Touzalin, Topeka, Kansas, that they may have a clear idea of the whole matter and form their judgment accordingly. This would be the more judicious, as the report in a measure will apply to the whole of that part of the country lying immediately west of the Missouri river and north into Nebraska, upon the lines of the Burlington and Missouri and the Union Pacific Railroads. The only point of difference being that the Arkansas Valley possesses, in the judgment of the person who made the report referred to, some advantages which the other localities do not. This may, however, be a matter of taste with some persons, who would choose a more northern locality, equally fertile, in the State of Nebraska, and where general farming may be carried on with equal comfort and success. As a strong corroboration of the truthfulness of the report we may state that the entries of United States land the past season in the Wichita and Salina United States land offices (the Arkansas Valley district) have amounted to 500,000 acres, and that the Atchison, Topeka and Santa Fe Railroad have sold during the same period, and since May, 1873, the following quantities of land, viz.: in June \$273 acres, in July 9,638 acres, in August 12,547 acres, in September 19,163 acres, and in October 23,676 acres, at an average price of \$5 to \$6 per acre. This does not look as though there were many disappointed persons taking a back track. On the contrary, we have letters from parties who have settled there expressing themselves well satisfied with their present success and future prospects, and with the abundant fertility and great healthfulness of the country.

Other "Basket" Items will be found on page 75.

Going West.—"D. M. C.," Independence, Iowa. It is useless to blind one's eyes to the fact that a vast emigration is going westward. At the same time every westward-bound man leaves a successor in his place in the east. It is the natural expansion which has ever been at work in this country since the first emigrants landed. It is impossible to stop it; it is the wisest course to direct rather than to stem the current. A dozen years or so ago your own state was peopled in exactly the same way. Now Kansas, Nebraska, Minnesota, Colorado, and other states are filling up. To tell an American farmer to stay where he is or his boys to remain with the old folks is to tell them to do something they will not do, and it is labor lost. There are a few who go to see and return more contented with their old homes, but they are a very small minority. The railroads are the effect, not the cause of this western emigration, and the new settlers are by far more greatly benefited by the roads at present than the roads by the settlers. At first there are hardships and disappointments for both, but by and by as in Iowa and Illinois, both become profitably established.

Books Noticed.

STAR PAPERS, by Henry Ward Beecher: J. B. Ford & Co., New York.—This, like several other volumes in this list, has been on hand for some time waiting until we could find space to notice it. Fortunately it is one of those books that do not lose their freshness. Most of the articles were written twenty years ago, and they will be just as bright twenty years to come. This volume

contains some of the best of Mr. Beecher's miscellaneous writings, and in saying this we give it sufficient commendation.

HOW TO PAINT, by F. B. Gardiner: S. R. Wells, New York.—Almost any one of ordinary "gumption" can learn to paint sufficiently well to do ordinary jobs about the house and premises. To those who wish to do their own painting this little work gives hints about mixing and applying colors that will essentially aid the novice. Price, 75 cents.

ELEMENTS OF ANIMAL PHYSIOLOGY, by John Angell; a reprint of an English work by G. P. Putnam's Sons.—This seems to be a very compact and comprehensive little work, giving much useful information, and well illustrated. Messrs. Putnam are to be congratulated upon the generally excellent character of their elementary science series, of which this work is a part.

HANDBOOK OF THE TREATMENT OF THE HORSE, by Charles Wharton: J. B. Lippincott & Co., Philadelphia. Most works upon the horse and its management are too bulky and cumbersome. This neat little work of 137 pages contains about all that a person who keeps but one or two horses needs to know. Besides the portion which relates to general care and management, it gives an account of such ailments as can be safely treated without the advice of a veterinary surgeon. Price, \$1.25.

HANDBOOK OF HARDY TREES, SHRUBS, AND HERBACEOUS PLANTS, by W. B. Hemsley: Estes & Lauriat, Boston.—This work is based upon the excellent work, *L'Amateur des Jardins*, in 4 vols., by Decaime & Naudin, although it can hardly be called a translation of it, as the arrangement is different, and it includes only the hardy plants. This work, however, presents the same elegant illustrations as the original. From our knowledge of the French work we are safe in commending this to those who wish to know something of the botanical relationships of the plants they cultivate. As far as we have examined it, the work appears to be well done and the descriptions remarkably free from technicalities. Price \$7.50.

DOMESTICATED TROUT. How to Breed and Grow them, by Livingston Stone: James R. Osgood & Co., Boston.—This is not a very recent work, but it has been overlooked until now. Mr. Stone is a high authority in pisciculture, and has done much towards introducing fish into our waters. This work contains a very full account of the art and mystery of trout raising, and is produced in the excellent style characteristic of the house by which it is issued. Price \$2.50.

CHIMNEYS, FURNACES, FIREPLACES, and Steam Boilers, and Steam Boiler Explosions are Nos. 1 and 2 of the neat science manuals issued by D. Van Nostrand, New York. No. 1 is by R. Armstrong, and No. 2 by Zerah Colburn. They are small handbooks of 75 to 100 pages each, and must be very useful to all who have to do with furnaces and steam. Price 50 cents.

RATIONAL HORSE-SHOEING.—This little work is descriptive and explanatory of the method of shoeing horses with the Goodenough shoe. It is a book that should be read by every horse owner, because it teaches a rational system of treatment of the horse's foot, by following which the greater part of the troubles which affect the foot of the horse may be avoided. Unfortunately, few owners of horses are sufficiently educated in this respect to enable them to resist successfully the ignorant and injurious methods of shoeing practiced by blacksmiths, by which the hoof is hurned and its most important and necessary parts are cut and hacked away. The system taught in this book is in operation in most of the largest horse-car stables in New York and Brooklyn, as well as in those of the owners of some of the most valuable high-bred horses. This fact is alone a remarkable indorsement of this practice of treating the hoof of the horse.

Catalogues Received.

LANDRETH'S RURAL REGISTER and Almanac for 1874.—This contains, besides an almanac and useful calendar of operations for each month, a catalogue of the seeds raised and sold by the old and reliable house of David Landreth & Son, Philadelphia.

HIGHTSTOWN NURSERY.—Thomas J. Pullen succeeds his father, Isaac Pullen, at one of the oldest nurseries in the country, at Hightstown, N. J. This nursery makes a specialty of peaches.

THE FLOWER GARDEN.—Beach, Son & Co., 76 Fulton street, New York, publish their seed and bulb catalogue in the form of a quarterly journal. The portion devoted to horticultural matters is ably managed.

B. K. BLISS & SONS publish a tender to their enormous illustrated catalogue in the form of an "Abridged Catalogue and Gardener's Almanac." This contains all the

novelties of the season and the leading articles in the larger catalogue in a compact form.

BRYANT'S NURSERY.—The catalogue offers a good assortment of fruits and an especially full list of evergreen and deciduous ornamental trees. Another list contains a large variety of tree seeds, especially those of native kinds.

CHARLES A. REESE's catalogue of plants and seeds presents an attractive list of the standard varieties. His place is at Pleasantville, Venango Co., Pa.

HENRY A. DREER, Philadelphia, catalogue for 1874, contains the usual standard flower and vegetable seeds with several novelties and specialties.

The following European catalogues have recently come to hand:

A. CHAROZE, trees and greenhouse plants, Trclazé, near Angers, France.

J. MONNIER & Co., seeds, Trclazé, France.

CH. HUBER & Co., Hyères.—This is one of the largest seed-growing houses in France, and their catalogue of both vegetable and flower seeds is very full. They also offer fine greenhouse plants.

J. C. SCHMIDT, Erfurt, Germany, seeds, plants, and trees. Bouquets and ornaments of dried flowers are a specialty with this establishment, and their illustrated catalogue shows to what a wonderful extent this trade is carried on.

LOUIS VAN HOUTTE, Ghent, Belgium.—Probably no horticultural establishment in the world is better known than Van Houtte's. The present catalogue is mainly devoted to Alpine and herbaceous plants.

JAMES BLACKLEY, Leyton, London, Eng., has a catalogue entirely devoted to new varieties of carnations, with the varieties handsomely illustrated.

BENJAMIN REID & Co., Aberdeen, Scotland.—Catalogue of timber trees, conifers, and shrubs.

Bee Notes.—Advice to Beginners.

BY M. QUINBY.

It was probably colder during the month of November, 1873, than ever before in this latitude so early in the season. The coldest morning was two degrees below zero. December was very mild. The snow of November is about gone, and the mercury has been down to nine degrees once or twice only. Had I known that the weather would be as it has been, and that it would continue so throughout the winter, I should not have advised housing bees, even in this latitude. The pleasant sunny days have been frequent, and all-sufficient for their health. Those who have been negligent or heedless, and left them in the open air, if January proves mild, may let them remain. Look to them often. See that dead bees do not fall down and choke up the entrance. With a bent wire all can be cleaned out at any time; or, if warm enough to melt snow and ice, raise the hive occasionally and sweep out all clean. If mice have been at work small crumbs of comb will be scattered on the bottom board, which will suggest a trap at once. Do not mistake the brown particles like pin heads, perhaps smaller, that will be seen on the bottom board, for crumbs of comb. These particles after cool weather commences, may always be seen, and are worth observing closely. The quantity indicates the size of a colony, better even than a sight of the bees. If no mice scatter it, it may be seen directly under the spaces between the combs in little ridges sometimes a half inch in depth. If the cluster is strong and the time of confinement has been long there will be a large quantity. You may tell the exact number of combs that contain bees between them, and how far they extend each way, by the length and size of the ridges. In purchasing stocks in winter observe this first, and any hive not showing streaks of this substance under more than one or two combs you may be satisfied has but few bees without looking to see them. It is not profitable to buy such for stocks at any price. When bees are in health it is apparently dry, and but few dead bees are mixed with it. Until very recently I had supposed it was simply the fine particles of wax that had covered the sealed honey in the cells, and bitten to pieces by the bees in getting at the honey. Having observed it in some colonies where there was no sealed honey, or but very little, it gave rise to the idea of its being excrement in a dry state. When bees are filled with honey, and become chilled, if only for a short time, they do not seem to digest their food properly, and their excrement is discharged in liquid state—a sort of dysentery—in or outside the hive. Bees have been confined in comfortable quarters for seven consecutive months without discharging any faeces unless in a dry state. These facts suggested the idea that this substance, or a portion of it, may be the excrement of bees in a healthy state. Whether it proves to be mixed with excrement or otherwise, it will give a criterion to judge of the health and

size of colony. Whenever the excrement is discharged inside in a liquid state it indicates that it has been too cold. The remedy is to make them a little warmer. Analysis of this dust may give us further light on other points.

Those who have taken the precaution to house their bees need have no uneasiness about them, as very likely they will require less care than otherwise. If severe cold has been anticipated, and arrangements to protect them against it have been made, there may be a little danger of their being kept too warm. A thermometer costs but little; the satisfaction of knowing instead of guessing how cold it is is great. Hang one in the room with the bees, and if the temperature is nearly steady, and does not go above 50° Fahrenheit, they may be left quiet, and if the least ray of light is not admitted they will not be likely to waste. I know of a lot of bees that were put in a dark, dry, warm cellar on November 10th. Have now been in fifty days. The temperature has varied only from 47° to 49° during the time, and bees never seemed more comfortable and quiet. Should the warmth at any time go much above 50°, I would recommend introducing into the room a quantity of snow or ice, to cool it properly, rather than set them out before the proper time.

Profit from Hot-Beds.

J. B. ROOT, ROCKFORD, ILL.

There is scarcely a town of 5,000 or even 3,000 inhabitants, but where the gardener or florist can make an important and very profitable addition to his business by growing and selling hot-bed plants for the garden. Two causes have operated to prevent a full development of this branch of business in our smaller cities and towns.

First, while florists and gardeners in our large cities have abundant capital, their brethren in smaller towns, and especially in the West, either have but small means, or else have other urgent demands for them; so they are unable to make the required investment in glass and fixtures. Secondly, the plants usually produced are not sufficiently stocky and well hardened to attain extensive sale.

In showing how these difficulties can be obviated I shall not state merely what *can be done*, but shall confine myself strictly to what *has been done* in my own experience during the five years past. Glass sashes 3 × 5½ feet ready for use usually cost \$1 each, making \$16 for a bed of four sashes. The interest upon this is \$1.60, and the wear and tear as much more, making an annual expense of \$3.20 per bed, and demanding an investment of \$400 for glass in carrying on twenty-five beds. Believing this to be an unnecessary expense, five years ago I began using prepared sheeting, and with such satisfaction that it now constitutes four fifths of my covers. To render the sheeting more transparent and at the same time make it air-tight, use the following preparation: 1 quart linseed oil, 1 ounce pulverized sugar of lead, 4 ounces pulverized rosin; heat in an iron kettle till all is thoroughly dissolved and mixed. Apply while hot with a brush to the muslin while stretched over a frame. Endeavor to apply when two successive clear days can be had to dry it well before placing it over the vapor and heat of a bed.

Before applying this two widths of muslin are stitched together of such length as to make them a few inches longer than a four sash bed. The edges are hemmed (also on the machine) and small brass rings sewed on firmly at fifteen inches apart around the whole border. By hooking these over small nails or inverted hooks the cover is stretched nearly air-tight. When it is desired to open the beds they can be unhooked and rolled down as far as desired and fastened, or rolled entirely off upon a clean

board at the foot of the bed. Ready for use these cost in money \$1.25, and in labor enough to make the entire cost nearly equal the interest on glass for one year. In careful hands they will probably last three seasons. My own last two seasons and are used for weeks together in the field for gathering turpentine, lettuce, and other dry seeds, and in the fall in drying cucumber, tomato, and similar pulpy seeds.

For use on the earliest beds in the short days of February, I prefer glass because it gathers heat quicker during the few hours of sunshine. If a week of cold, cloudy weather occurs in April, of course cloth covers have their disadvantages, but I have never suffered an actual loss from them, while annually with such help as we are compelled to hire I lose something from the glass beds, and taken altogether I prefer cloth for most uses after the 10th of March. They do not gather heat so rapidly during the day as glass does, and hence there is less danger of burning or drawing plants, nor do they throw off heat so fast at night, and hence need less covering. Fitting tight to the frames they admit of no draughts, undergo no sudden changes, and suffer little from dampening off. They are safer than glass in inexperienced hands, and are handled and stored at less expense.

Plants grown under such covers I am annually selling in large amounts and shipping to other points where they are brought in competition with plants grown entirely under glass, and I have never heard anything to their disparagement. They are of course equally as serviceable in the private garden as for commercial purposes. [Our space will not allow us to give Mr. Root's method with tomato plants; we can only state here that he sows the seed late in February in shallow boxes placed in a strong hot-bed, and to guard against accidents repeats the sowing every week or ten days. The details of his after treatment will be given next month.—Ed.]

Watering Stock in Winter.

We wish our readers would make the following simple experiment. You have a trough or half barrel into which you pump water for stock. There is more or less ice in the water. Your cows and sheep are drinking it. Put a thermometer in this water and you will probably find that it is within a degree or two of the freezing point. Then pump up a pail of water, and if the pump has not been used for a few hours you will find (at least we did) that this water is also down to 33° or 34°. Now pump two or three more pails of water, or until you are sure you have drawn up all the water that has been standing in the pump and are now drawing it fresh from the well. Let the thermometer stand in this a few minutes and you will find that this water is not far from 50°—or say from 15° to 20° warmer than the first drawn water or than that standing in the trough. In the summer, nearly every farmer when he wants drinking water will pump out the water that has been standing in the pump because he knows that it is warmer than the water in the well. We should do the same thing for our stock in winter, because this first drawn water is much colder than the water in the well. It has been found very advantageous to artificially warm water for horses and cows. We can not all adopt such a plan, but we can take measures to give our animals water fresh and warm from the well. We can avoid compelling them to drink water in which ice has

begun floating for some hours. A cow drinks, or ought to drink, not less than 75 lbs. of water per day. This water has to be raised to the temperature of the body—say 100°. The heat required for this purpose is derived from the combustion of corn, hay, or other food. Those at the East think it a sad waste when they hear that Western farmers burn corn in their stoves to cook their food or warm their houses. Are they not more to blame for reducing all the water their animals drink from 50° down to 32°, and then burning corn-meal to restore these 18° of heat?

Agassiz.

Everywhere that papers are read is the death of Agassiz known, and those must be rare indeed who have not perused some account of his life and labors. Some of the illustrated journals have given portraits of the great naturalist, but they are so unlike Agassiz as we knew him before the illness of a few years ago caused him to suspend his labors for a long time, that but for the name below the pictures we could not guess for whom they were intended. Thinking that many of our readers would like to see a representation of him as he appeared in full vigor, we have had an engraving made of a photograph for which Agassiz sat at the request of the writer several years ago.

Although not an agriculturist, his portrait properly finds a place in an agricultural paper, as, many-sided man that he was, he had a more profound knowledge of the principles upon which its successful following depends than many who devote themselves especially to agriculture. As a member of the Massachusetts State Board of Agriculture he thoroughly identified himself with the farmers, and at its meetings, from which he was never absent unless ill or upon some distant journey, he was ever ready to impart instruction, and by his enthusiasm in regard to matters relating to agriculture awaken a like enthusiasm in his hearers. It is not necessary here to speak of the scientific eminence of Agassiz nor of the great works upon which it rests, as these have been so recently recounted as to be fresh in the minds of all readers. Aside from the great popular respect in which he was held for his scientific labors, he was regarded by the people at large with a feeling of warm personal regard. Upon the lecture platform he had a singularly attractive manner; he made his subjects so plain, and adapted himself to the commonest comprehension without appearance of "talking down" to his hearers. Indeed he would speak of things that were as familiar to him as the alphabet with such enthusiasm that one would suppose they were the discoveries of the moment and he was for the first time making them known.

His popularity as a public lecturer was unparalleled, but he found that lecturing interfered too much with his scientific work, and in later years seldom appeared outside of his own lecture-room or the public meetings of the Massachusetts Board of Agriculture. Personally, Agassiz was one of the most accessible and genial of men, making friends wherever he went and with all classes. Even the fishermen, who are not given to admiring those outside of their own craft, had a word of praise for Agassiz. A little personal incident may not be out of place, as showing something of the unassuming character of the man. Soon after Agassiz came to the country, the writer

was with him at a large party given in his honor in a New England town in which he was giving some lectures. At the party Agassiz was as "beaming" and as interesting as one could be. We noticed that at the refreshment-table he was very abstemious; and soon after this part of the entertainment was over, he intimated to us a desire to leave, and we quietly departed. No sooner had we fairly left the house than he began to hop, skip, and jump in a most astonishing manner. "There, that is over," he said; "now let us go and enjoy ourselves." Oysters were suggested, and, though it was rather late, we found a place still open where we were soon seated over our oysters. Having been brought up in a place celebrated for its oysters, we supposed we knew something about them; but Agassiz soon convinced us that we had much to learn. The talk of that night will not be forgotten. He ran on in his own charming manner with the whole history of the oyster, from the "spat" to its full growth, the difference of oysters in other countries, the manner of their economical cultivation, the various parasites and enemies of the oyster and much more besides. Finding that the watch showed after one o'clock, we rose to retire, and found that the oysterman and his assistants were all standing around at a respectful distance, with eyes and mouth wide open, quite willing to be kept up to this unusual hour while this wonderful man discoursed. Agassiz's memory was something remarkable, not only for scientific facts but for common names. He once said to the writer, upon expressing surprise that he should remember the names of persons whom he had seen but once, "I never forget a name when I once know it."

However important his published works, the great museum which he founded, and the Anderson School of Natural History, the great and lasting influence of Agassiz will be found in the impulse he has given to the study of natural history in this country. When he first came among us naturalists were very few, only here and there one working by himself; now they are numerous and to be found in every state and territory. Falling in his 67th year, in the midst of his usefulness, his name will be honored in all civilized countries. We could not do less than give this humble tribute of respect to his memory.

Ogden Farm Papers.—No. 48.

Coming home again, after three months' absence, I found things "as well as could be expected under the circumstances," but circumstances had not been favorable. The well from which the windmill forces water to the barn and to the dairy, and which has never failed before, though sometimes nearly dry, had this season to be sunk eight feet deeper, and went dry after all. The house well went so nearly dry as to give a very scant supply for the milk pool, and the brooks disappeared from the face of the earth—everything went dry except one stream more than two miles away. From this all the water used on the farm had to be hauled for weeks, and the vat in which the deep milk-cans are set, not having the fresh spring water for which it was intended, had to be kept cool by the constant use of ice. Pastures were pinched down to the shortest bite, and the corn fodder on which we usually depend for almost the entire feed of the latter part of the season, and for an abun-

dance of winter forage, was nearly all of it dwarfed, the early season being too cold for strong growth, and the dry weather cutting short all that was not well started—so that the store left for winter use was almost nothing. In short, the drouth had evidently been much the most severe we have ever had, and any farmer will know what that means.

At the same time, I had decided that I should buy no more hay—that part of the improvement of the farm is, I am glad to say, finished, and the land is now able to make a good stock of manure for itself—and the crop of the year had been good enough to allow me to stick to the decision. My Illinois herd would take away about twenty-five head of Jerseys, and I could make good arrangements for the winter for all the calves, dry cows, and colts on a farm near by where I have plenty of hay. So we went into winter quarters with only eighteen head of horned cattle and the working mules. With this small stock, and with the hay all of the best quality and early cut, the steaming apparatus is laid by for this season, and we are pulling through the winter very comfortably after all.

I am not insensible to the pleasure and advantage of writing this series of papers; but I sometimes feel the annoyance of it, and wish that less publicity need be given to my farming. Of course, visitors are always welcome, and it is to be expected that those of them who write for the papers will print the result of their observations. It would be sometimes pleasanter if they did not. One well-disposed writer from Pennsylvania came in the very height of the drouth. He spoke no German, and my people speak little English. He went away and wrote his impressions—and evidently with a disposition to say as much for Ogden Farm and as little against it as he possibly could. Yet this is the impression he gives:

The Jerseys are all right; when compared with many in Pennsylvania the farm suffers by comparison (of course it does, most of the farms of this country do); one field was said to have cut four tons per acre, he would have guessed one ton (it cut four tons in 1872 in the whole season, in 1873 not much over two and a half, owing to the drouth); the drains were not running, the windmill well was dry, we have to drive miles to water, and would find the salt sea nearer; underdraining seems not to prevent drouth; we were, in spite of all this, making an average of 6½ lbs. of butter per week from each cow (not true, for we are buying considerable of milk in addition to our own); the cows average 10 quarts a day (at that season it was not over 7); to make a pound of butter requires over 10½ quarts of milk (of our own milk at that season it took 7 to 8 qts.); the pool for the deep cans is supplied from a spring at the bottom of a well, 75 feet deep, close by, and the water is drawn and put into it by hand, which takes a man six hours a day (this is only during a rare drouth like this, and even then only a few buckets of water are put in each day to keep up the quantity, and ice is used to keep it cool and fresh); the pool does not contain running water, as we supposed, "but is simply an open cistern" (it is supplied with fresh water by every wind that blows, except in times of such drouth); and so on, pretty nearly to the end of the chapter. The report is friendly and on the whole complimentary, but the real facts of the case at Ogden Farm are about as incorrectly stated as they

could have been by an intelligent man with every desire and disposition to state them correctly. I can only hope that my ignorance of Dutch and Wouter Sluis's imperfect English did not so much interfere with my impressions of the Bermster in Holland.

Recently, in feeding our cows, we came upon a part of the mow where we had put away several tons of clover from a newly-seeded meadow. We have now fed this exclusively for two weeks, and although the hay fed before it was very good (mostly red-top) the milk of the whole herd has increased *fully sixteen per cent.* Comment is unnecessary.

Gen. Tilton, the director of the National Soldier's Home near Augusta, Maine, has recently published some statistics of the dairy of that institution which are instructive. He has since sent me the weights of the animals in question, and the whole statement of the case is as follows:

MILK FOR THE YEAR ENDING OCT. 23, 1873.

Breed.	Number.	Weight of each animal, Dec. 17, 1873.	Age.	Period of weighing, in days.	Number of days in milk.	Whole product in pounds.	Average per day during the whole period.	Average per day while in milk.	Per cent of cream in milk.
Holsteins....	1	1230	6	365	285	4123	19.51	25.00	13.33
		1231	4	"	365	6315	18.67	18.67	11.66
Grades.....	1	1110	6	"	233	5370	15.26	19.63	8.33
	2	1250	5	"	365	4979	13.64	16.12	15.00
	3	1002	10	"	275	4686	12.84	17.00	13.33
	4	980	10	"	365	4566	11.96	11.96	13.33
	5	905	6	"	365	4251	11.73	14.03	16.66
	6	1208	8	"	261	4319	11.83	16.54	11.66
	7	980	3	"	295	2345	7.80	9.64	11.66
	8	1150	7	183	133	2432	13.29	19.77	13.33
	9	1127	8	"	123	2179	11.90	17.71	15.00
	10	952	7	"	123	2082	10.83	16.90	15.00
Jerseys.....	13	871	3	365	302	4205	11.52	13.90	18.33
	14	826	4	"	334	4024	11.02	12.04	18.33
	15	979	9	"	305	4004	11.97	13.12	21.66
	16	1007	8	"	320	3728	10.21	11.65	33.33
	17	958	9	"	339	3791	10.38	12.27	15.00
	18	1012	7	"	365	3654	10.00	10.00	23.33
	19	860	4	251	166	2905	11.54	17.50	23.33
	20	698	2	72	72	1162	16.13	16.13	20.00

Breed.	Aver. days in milk.	Average of whole product in lbs.	Average per day in pounds.	Av. per day while in milk, in pounds.	Average loss by being dry, per cent.	Average quarts per year of 2.15 pounds per quart.	Per cent of cream.	Average cream, per year, in quarts.
Holsteins.....	325	6930	19.00	21.83	12.50	3241	12.50	405
Grades.....	298	4425	12.11	15.93	24.00	2062	13.33	275
Jerseys.....	322	3901	11.60	13.32	13.66	1814	21.67	393

Discarding fractions, the average weight of the three classes was: Holsteins, 1,225 lbs.; Grades (natives?), 1,067 lbs.; Jerseys, 901 lbs.

"The grades," says Gen. Tilton, "are the best of their class, having been selected with special view to their milking qualities. The cows were in no case overfed. They have had little or no feed except hay in winter, while in summer they have had poor pasture, supplemented with green-corn fodder at night."

The proportion of milk (average per day for the whole year) as compared with the average weight of the cows of each class was:

Holsteins, 1 ⁶⁶ / ₁₀₀	per cent of live weight.
Grades, 11 ⁴ / ₁₀₀	" " " " "
Jerseys, 12 ⁸ / ₁₀₀	" " " " "

The proportion of cream may be best stated as follows:

- Of Holsteins, it took 3⁷/₁₀₀ lbs. live weight to produce one quart.
- Of Grades, it took 3⁵⁵/₁₀₀ lbs. live weight to produce one quart.
- Of Jerseys, it took 2²⁰/₁₀₀ lbs. live weight to produce one quart.

The foregoing tables and calculations may be with advantage considered in several different lights, but there is one that is especially important to butter makers:

If an animal (other things being equal) consumes food in proportion to its weight, then, in order to make as much cream from the other breeds as can be made by a Jersey consuming 2,000 lbs. of hay, we must feed a Holstein 2,649 lbs., or a Grade (of the kind and quality used by Gen. Tilton) 3,402 lbs. Of course, the surplus would not be all wasted, the Holstein would make more skimmed milk (containing caseine), and the Grade would probably gain flesh, while the Jersey would keep thin. Still, when butter is the object, and no equally profitable use can be made of skimmed milk or flesh, the profit lies heavily on the side of the Jersey. I believe that a quart of Jersey cream will make more butter than a quart of cream from either of the other breeds, but this is only a matter of opinion, not of positive knowledge.

Whether cows do consume food proportioned to their live weight is a question which it is to be desired that some one would settle by careful experiment. Probably a thin animal would eat more in proportion than a fat one, but the weights and ages of Gen. Tilton's Jerseys show that they were not thin. When I saw his herd, two years ago, they were in excellent condition of flesh.

Mr. H. B. Gunler, of De Kalb, Illinois, has asked for an opinion on this question. He puts it thus: "If one of two cows of equal weight will produce 25 to 30 per cent more butter (or milk of the same quality) must she not require more food, or are her digestive organs enough better to make that difference? I should think that after allowing an equal amount for the support of each cow's system they must require food in proportion to milk or butter produced unless one has more of a tendency to put on fat than the other."

This question covers a good deal of ground, and I have found nothing in my reading that enables me to answer it very definitely, nor have I ever been so situated as to experiment with sufficient care and to sufficient extent to decide it. At the same time, one would think that a matter of such vital importance should have been elucidated before this time. Gen. Tilton's experiment throws much light on it, but does not go far enough. The experiment should be made with animals of about the same age, of the same breed, in the same condition as to pregnancy, and in the same state of health. They should be weighed every day, and note should be made of their daily condition; their milk should be weighed at each milking, the milk of each should be creamed separately, and the amount of butter the cream of each makes should be noted; the food of each should be carefully weighed; it would add to the value of the experiment if the cows were divided into two or more lots and fed differently (alternating the food of different lots from time to time); and, still further, if special additions of grain, etc., be made to the food.

In the absence of such definite experiments it is impossible to answer Mr. Gunler's question with precision. The opinion I should give would be an opinion only, but it would be that the better producer of the two cows would not only eat more food, but would also convert more of what she did eat into the products of the udder. If they consumed like quantities

of food one would doubtless take on more fat than the other, and more of her food might pass in the manure. There can in no case be a loss of the elements of the food. It will form either milk, flesh, or manure. A close observation on the part of the farmer will enable him to judge with much accuracy which animal converts the most of her food into one product and which into the other; but there can be no certainty short of actual weight and measure in a carefully conducted trial. Certain breeds have special tendencies. The Shorthorns for butchers' meat; the Dutch cattle (erroneously called Holsteins) for milk; and the Jerseys and Guernseys for butter. In each class there will be individual tendencies to a greater or less concentration of the nutriment in the product for which the race is distinguished, but so much of it as does not go to this must go to one of the others—or to the manure heap, which is a waste as compared with the product for which we seek.

I have a letter from a former correspondent who complains of too rough handling in the Ogden Farm Paper for October. He says he did not mean any disparagement of foreigners, only that right-minded young Americans do not like to work under them, and that this is one of the reasons why they leave the business of farming; that there is a disposition in America to use foreign help and foreign wares simply because they are foreign, and that if gentlemen who go to farming would employ American foremen they might get American laborers. It seems to me that this would hardly do much to "keep young men on the farm," for the simple reason that they can generally do better than to work by the month. A young American who has in him the stuff for a good farm laborer usually has enough of another element to make him ambitious to be something better; he goes to another occupation, or takes a farm on shares, or manages (or tries) in some way to improve his condition. The greatest objection to him as a hand is that he don't *stick*. He works well while he works, but he is always longing to better himself, and that makes him unreliable. The same is still more the case with American foremen. If they are worth having they are out of place, and they soon find it out and get farms of their own. There are exceptions, of course, but this is the rule. It is not so easy for foreigners to get farms of their own, and this leaves a better class of them from which to choose foremen.

I think the main reason why we use so many foreign goods and employ so much foreign help is because at the same price we get a better article, and I know of no better reason that we could have. So much of my remarks as gave displeasure to my young friend were brought out by his misuse of the word "Americanism," and he says he did not mean by this what I supposed he did.

I have just made up my dairy woman's account. She gets a bonus of one cent per pound on all butter sold at \$1 per pound. This amounted from May 1st to December 31st, to \$34.88. In addition to this we sold several hundred pounds before the Newport season commenced for less than \$1.

Considering the drouth I think we may be satisfied.

J. H. Y. asks about crops for soiling. He intended to sow a patch of rye early in the fall for early spring feed, and another late in the

fall for late spring feed (one acre in all), and then to plant two acres of drilled corn for fodder; and wants to know how many cows he can keep from time of first feeding rye to end of corn feeding. The arrangement is not a good one. Probably the late and the early sown rye will shoot at the same time in the spring, the chief difference being that the early sown will make the heavier growth. Rye is only useful for a very early feed. As soon as it blooms it imparts a bad taste to butter, and the straw early gets too hard to be relished by cattle.

A better arrangement would be: $\frac{1}{2}$ acre early sown rye, $\frac{1}{2}$ acre early sown oats, 2 acres corn, planting at four different times from May 15th to July 1st in plots of $\frac{1}{2}$ acre each.

"The cattle having the range of six or eight acres of moderate pasture," the soiling crops should suffice for the supplementary food of from eight to twelve cows, according to how "moderate" the pasture is, and how good the land growing the soiling crops.

Stock Breeding.

THE IMPORTANCE OF GOOD BLOOD AND GOOD MANAGEMENT.

BY T. C. JONES, DELAWARE, OHIO.

If anything can be regarded as settled in the theory and practice of American agriculture it is that, except in the immediate vicinity of large towns and cities, and possibly on the rich cotton and sugar lands of the South, the business can not be made profitable without including the growing or feeding of stock; which is found to be indispensable to the maintenance of the fertility of the soil and the success of that mixed system of husbandry without which we have no protection against the disastrous effects of low prices and unfavorable seasons upon particular crops or products. The opinion, therefore, which so generally prevails, that stock-growing must be abandoned in the older States for the reason that their high-priced lands can not compete with the cheaper lands of the new States and Territories, is manifestly erroneous; because, whatever changes may be required in the practice of agriculture in the older sections, in view of the competition of the rich corn and grass lands which by a mistaken policy are being forced into occupancy in advance of the actual necessities of the people, it seems obvious that so long as the land is used for the production of crops the grazing and feeding of live stock can not be dispensed with.

This is demonstrated by the practice of the farmers of Great Britain, who, notwithstanding the high price of land and of all varieties of tillage crops, pay more attention to stock breeding than any other people in the world. The course of agriculture in our own country teaches the same lesson. I remember the time when the feeders of the Scioto Valley grazed their cattle on the prairies of Illinois; and predicted that in a few years this great State, with its matchless soil, would be able to raise cattle enough to break down prices so as to render the business unproductive in the older States, just as we now hear the prediction that Texas and the Territories will soon grow the beef for the whole United States. But what have been the actual facts? Illinois, though surpassing the most sanguine expectations as a corn and grass-producing State, had, according to the last census, less than one hundred and fifty

millions of dollars invested in live stock, while the old State of New York had nearly one hundred and seventy-six millions. The live stock of Missouri is reported as worth eighty-four millions, while that of the old Keystone State is set down at more than one hundred and fifteen millions, and Ohio at over 120 millions. Texas, with all its advantages as a grazing country, and an extent of territory equal to a half-a-dozen of the old States, has only 37 millions in live stock, while Michigan has nearly 50 millions.

It is also to be observed that while the Western States, excepting Texas, are rapidly increasing in live stock, as in all other products of agriculture, the older States are also making very respectable progress. Thus, while Illinois between 1860 and 1870 added 77 millions to the value of her live stock, New York during the same period added 73 millions. The increase in Pennsylvania was 46 millions, while in Missouri it was only 31 millions.

These facts are quite significant as indicating the prominence which this great interest has, and must continue to maintain, in American agriculture. It is therefore safe to assume that in the future, as in the past, the prosperous farmer will be the man who handles most judiciously his live stock; for it is unquestionably true that while this branch of industry is, when properly managed, the most profitable, as it is the most interesting, connected with our vocation, it is the most disastrously unprofitable when the management is bad.

For example, a man who allows his growing stock, say cattle, pigs, or sheep, to run down during winter, so that, instead of gaining, they lose in weight, will lose his entire winter's keep, because his animals are worth less in the spring than they were the previous fall. And so the man who buys a lot of badly formed scrub cattle, because they cost less than good ones, will lose a heavy percentage, because they will not "lay on" flesh as well-bred cattle would on the same feed; and when brought to market they will have to be sold for at least 25 per cent less per 100 lbs. on account of their inferior quality and weight.

If for breeding or milch cows inferior animals and inferior blood are procured, the result will be still more disastrous. If we select a good cow that will give a fair quantity of good milk, and of such form and blood that her calves will be worth raising, and that can be converted into a good carcass of beef when no longer wanted for breeding or for milk, we shall have made the most profitable investment that pertains to legitimate agriculture; while a cow with qualities the reverse of all these will be the most unprofitable thing that could be selected. The same observations will apply to stock breeding in all its branches. "Blood will tell"—if you give it a chance—but an ill-bred and ill-formed animal will usually "eat his head off" under the best management.

It was in view of this undeniable fact that the great Bakewell insisted that everything depended on *blood*. You must have a good *sort*, and having this reserve only the best for breeding. Insist upon "the survival of the fittest" only for breeding purposes, and thus if you feed well, so that your young stock is always kept in a thriving condition, you will maintain the excellence of your stock and insure satisfactory profits from a branch of industry that is as interesting to men of the highest culture and refinement as it is essential to the daily wants of the world.

Morgan Abdallah.

The engraving represents a four-year-old colt, Morgan Abdallah, the property of the Rev. W. H. H. Murray, whose farm is at Guilford, Ct. We had an opportunity of examining this promising young horse with one of his colts at the New England Agricultural Fair at Boston a few months ago, and were much pleased with him. He is a very handsome and beautifully formed animal, of a rich dappled bay color with black points. His disposition is remarkably gentle, and his training or rather his management up to the present time has been judicious and successful in making him perfectly docile, although he is not in the least wanting in spirit. He possesses a large share of Morgan blood, being descended from Justin Morgan on the side of both sire and dam. He has also the blood of Old Abdallah, through his grand-dam on his sire's side, who was by that renowned

horse. He has trotted a quarter of a mile in 43 seconds, although he has been harnessed but twenty times, and has never been shod. But while we do not undervalue in the least the attribute of speed in a horse, we look upon this as well as all other worthy representatives of the Morgan race as being in an especial degree the farmers' horse—the general utility horse in fact. Docile yet active and spirited in temperament; hardy in constitution; stout and trustworthy in the draft; sagacious and ready to learn, and, possessed of a good memory, remembering what he has once learned; a good worker; a good traveler and easily kept; he is probably the best horse upon a farm that can be had, and will do as much work as many a larger horse, and at a less cost and in a more satisfactory manner. Without disparaging in the least any other of our valuable and worthy classes of horses, we feel justified

in giving at least this credit to the Morgans. Many farmers find it best for them to keep a moderate-sized horse adapted for use in the plow as well as in the buggy, and available for heavy draft upon the roads,

and in the Morgans he finds precisely the horse he needs. Those who desire heavy horses will seek the heavier breeds, which have greater weight but at the same time less speed and activity. But it is a question if heavy horses are the most economical upon farms

fleece, which reaches in good specimens a weight of eight or nine pounds of medium wool, produce a heavy carcass of good lean mutton, are hardy, and bear a change of climate and pasture well, and are more prolific of lambs than some of the others of this class of

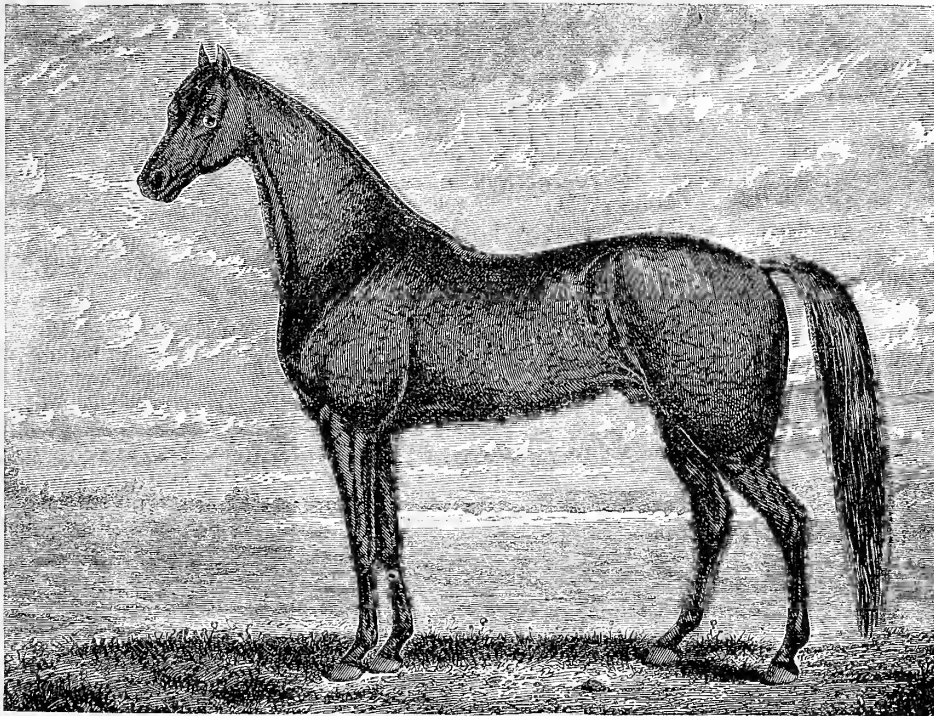

MORGAN ABDALLAH—PROPERTY OF THE REV. W. H. H. MURRAY.

where the labor is of a varied character, and where activity is more desirable than weight.

Shropshire-Down Sheep.

A portrait from life is here given of a pair of Shropshire-Down sheep imported recently with a considerable flock by Mr. Joseph Hoyt of Suisun city, California. This class of sheep

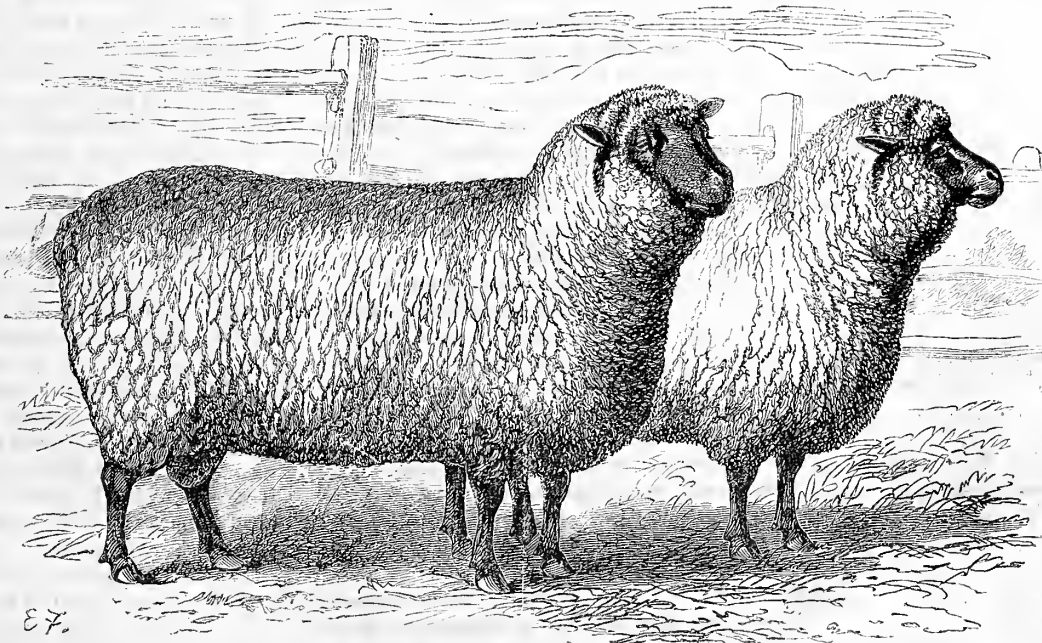

IMPORTED SHROPSHIRE-DOWNS.

is cross-bred, but has been bred so carefully for the last twenty years that they may now justly be considered as an established breed. They have the good points of both the South-Downs and the Cotswolds combined, bear a heavy

their mark there in improving the native Californian sheep. For this reason it is to be hoped that Mr. Hoyt's enterprise in personally selecting his flock from amongst noted prize winners in England, at a large cost of time and money, may be rewarded by abundant success.

EARLY EGGS.—Fresh eggs in the winter are one of those luxuries that farmers may command more readily than any other people. A fresh egg at this season is a rarity upon a farmer's table. Yet they are easily to be had. For many years we have never been without them. A few early pullets well fed throughout the fall, or even at this season, early in the winter, will lay by the end of December, or sooner, if they have been well cared for. Our plan was to prepare especially for a dozen selected young hens or pullets a warm dry house; to feed

them some meat scraps, boiled potatoes given warm, warm parched corn, and scalded wheat also fed warm, with some pounded bones and a few peppers occasionally mixed in their feed. Warm milk or curdled buttermilk was also oc-

asionally given to them. A large glass window in the house gave them light and sunshine, in which they basked in cold weather. For all this care we were repaid by a constant supply of eggs all through the winter, and by February or early in March some of the hens would set, and bring out early broods which would take their places the next season.

Walks and Talks on the Farm.—No. 122.

Last winter I found that there was great danger of my cellar freezing during a cold, windy night. It occurred to me that a little boiling water poured upon the cellar floor would be of some service. I said nothing about it, for I thought I should get laughed at; but after every one else had gone to bed I got a pailful of boiling water and sprinkled it about the floor and shut up all the doors and windows tight. It saved the cellar; and no one in the house ever knew what risk we ran of having frozen potatoes. I don't want to tell tales out of school, but it so happened that I wrote the next month's calendar for the *Agriculturist*, and in one of the "Hints about Work" I suggested this plan. I can recollect that I thought it hardly worth mentioning, but that at any rate it could do no harm.

One of my German neighbors said to me the other day: "That paper you and the Deacon write for is first-rate. I signed for it last year. I did not think I could afford it, but I wanted to see what the Deacon said about you. I wish I had taken it before. It saved me ten dollars."

"How was that, John?" I asked.

"Well, you see," he said, "I have got an awful cold cellar. When the stove goes out at night and the wind blows it's most sure to freeze. I had a lot of potatoes in the cellar, and thought they would all be spoiled. I read what was said in the paper about pouring boiling water on the cellar floor. I tell you it saved the potatoes. That editor is a smart man. I guess he is a German."

The incident pleased and amused me. It shows that one never knows what will or will not do good, and that those of us who "write for the papers" should not be afraid to mention a matter because it seems a simple thing.

John Johnston sends me an ear of his corn. "I think," he writes, "it is a very good kind, and if you have none of it I will send you a bushel for seed if I live until next planting time. It is called the White Flint. I had 158 bushels of ears per acre of 40 lbs. to the bushel. A man who buys a good deal of corn in the ear said he would rather buy this corn at 75 lbs. per bushel in the ear than have it shelled at 60 lbs. per bushel. He said he never saw any so well filled out."

The ear sent me contains eight rows, and there are 64 kernels to the row, or 512 kernels in the ear. My own corn is the common eight-rowed yellow. I got it from Mr. Dewey, who has taken great pains for many years to select the best ears for planting. I have just counted the kernels on one of the best ears, and found 57 in the row or 456 in the ear.

Mr. J. continues: "I drilled my corn at the rate of about five seeds to three feet in the row; rows 3 ft. 4 in. apart. I cultivated it thoroughly, but gave no hoeing except the two outside rows and about six feet at each end of the rows. So many suckers came up no weeds or grass could grow. It was as clean as it could have been

made if I had hoed it all the time. I got some stalks with two ears that gave from 740 to 950 kernels from one planted."

The Washington Co. Agricultural Society appointed a committee to examine a crop of corn raised last year by Mr. James W. Dickey, of West Alexander. The committee report that they selected three average shocks in different parts of the field and husked the corn. They got 19 half bushels of ears from the three shocks, or 3 $\frac{1}{6}$ bushels of ears to each shock. There were 1,104 shocks on the 15 acres. This would give 3,499 bushels of ears, or 233 bushels of ears of corn per acre.

The field had been in grass eighteen years. Last spring, as soon as the frost was out, it was plowed up at an average depth of 2 $\frac{1}{2}$ to 3 inches. The sod was well turned over and harrowed six times before planting. The land was marked out in rows 3 ft. 1 in. one way and 2 ft. 5 in. the other way. It was planted April 20th, and I judge from the report about four kernels were planted in each hill. This is very thick planting. When the corn was partly up it was harrowed with a common harrow. It was then cultivated twice in a row five times in all. At the last working the corn was up to the horse's back.

I have an idea that the report is designed to show the advantage of shallow plowing for corn. To me it shows the advantage of thoroughly working the land and keeping the manure or sod near the surface. Mr. Dickey keeps 950 sheep, and I suppose this field had been pastured for many years. A sod turned over only 2 $\frac{1}{2}$ to 3 inches deep and harrowed six times would be pretty well pulled all to pieces before the corn was planted. It would in fact be equivalent to a top-dressing of manure thoroughly worked into the soil. The frequent cultivating afterwards in warm weather would favor its decomposition and the corn roots would get a liberal supply of plant-food.

It is evident that Mr. Dickey does not believe in shallow plowing, for the committee speak of another 15-acre field of his that had been in corn two years that they thought would yield nearly as much as the other. This field was plowed shallow when in sod and planted to corn, and then plowed "very deep" and planted to corn again.

"It was those 950 sheep," remarks the Deacon, "that did the business. There is nothing like sheep for enriching land."

"I believe in sheep, Deacon," I replied, "but that remark is only true in part. It is not the sheep that enrich the land. A sheep can create nothing. A sheep returns to the land nothing more than it takes from it."

"Don't you think," said the Deacon, "that the sheep enrich your Northern Spy orchard?"

"In one sense yes and in another sense no. If I run a lawn mower over the field every few days and left the grass to rot on the surface I think the land would sooner or later be enriched by the mown grass as much as by the droppings of the sheep."

"The sheep kill the weeds," said the Deacon, "and bring in better grasses and clover."

"Mr. Lawes did the same thing," I replied, "by the use of artificial manures. It is not the sheep."

"I don't see what you are driving at," remarked the Deacon as he got up to go.

"Hold on, Deacon," I cried, "the weather is stormy, and you have nothing to do. What I want to say is that it is the growth of the grass that enriches the land, and not the sheep. Or,

to go back to the real root of the matter, it is the gradual decomposition of the organic matter and the disintegration of the inorganic matter in the soil itself that furnishes food for plants. If we carry off all these plants the land becomes poorer. If we feed them out on the land the soil becomes richer. There is no more actual plant-food in the soil, but what there is in a more available shape. This 15-acre field of Mr. Dickey's that had been pastured for eighteen years furnished a certain amount of plant-food every year from the inert matter in the soil. The air decomposed it, the rain dissolved it, and the roots of the grass took it up and the leaves organized it into food. The sheep ate the grass, converted the food into wool and mutton, and their droppings returned to the land some 90 to 95 per cent of all the nitrogen, phosphoric acid, and potash that the grass contained, and a still larger proportion of lime, soda, magnesia, and other mineral elements of plant-food. This plant-food was again taken up by the grass, together with the amount gradually rendered available by the decomposition of the soil. If the latter amounts to more than the small quantity removed in the wool, bones, and flesh of the sheep, the land gets richer and richer every year."

"You mean," says the Deacon, "richer in available plant-food; not that there is absolutely any larger amount in the soil. Now, what I want to know is what becomes of this extra amount of available plant-food. If it is soluble, why is it not washed out by the rains and lost?"

"That question opens too big a subject for us to discuss this evening. I may remark, however, that if you pour a solution of ammonia, potash, or phosphoric acid upon a soil it unites with certain ingredients in the soil and becomes comparatively insoluble. Again, in an old pasture the roots of the grasses contain a large amount of the plant-food which has gradually accumulated. An old sod contains several tons of organic matter per acre. And so it is not at all a difficult matter to see what becomes of the plant-food which is gradually developed from the soil. It is stored up in the soil and in the sod; and when you plow up the land the sod is decomposed and furnishes plant-food for the next crop. That great corn crop of Mr. Dickey's got more or less of the plant-food which had been gradually developed from the soil and stored up during the last eighteen years. The sheep did not create this fertilizing matter; they merely helped to preserve it and turn it to good account. The plant-food comes from the soil."

The Deacon was silent a few minutes, and then said: "I don't see, according to your theory, why our lands should not become richer instead of poorer."

"It is because so few farmers take pains to save the plant-food which is gradually developed from the soil. Instead of keeping sheep they sell the hay. Instead of draining the land they let the surface water run away with the soluble plant-food. Instead of cultivating the land and developing the plant-food they let the weeds rob the growing crops. Instead of carefully saving the manure they let the best portion of it run into the nearest ditch."

Farmers do not differ essentially in these matters from other people. The man that knows how to make money and to save it is the exception. It seems an easy matter to get rich, and it seems equally easy to make the land rich—on paper.

Let two young men begin life at twenty years of age with \$10,000 each. If one can so manage his property as to make it bring in ten per cent per annum, and can save and invest the whole, he will find himself worth when seventy years old \$229,347.98. Let the other spend his income, and draw \$500 a year on his principal, and his income will grow less and less every year, and at the end of ten years both principal and interest will be reduced one half.

And so it is with farming. The plant-food in the soil is the farmer's capital. That which lies dormant pays no interest. If land is left in a state of nature a small portion of the plant-food becomes annually available. It pays a low rate of interest. By cultivation, draining, etc., the plant-food is more rapidly developed, and a higher rate of interest may be obtained.

"I see what you are driving at," says the Deacon. "You mean that if a farmer tills his land he will grow good crops, and that if he sells these crops he is spending his income and drawing more or less on his principal; but that if he plows under these crops or feeds them out on the farm he is adding to his capital, and gets annually a larger income. In other words, his farm is getting richer and richer and more and more productive. This is all very well. But a farmer has got to sell something to get money to live on."

"No one, Deacon, understands that better than I do. All I want to show is that if a man can invest his money at a good rate of interest, and add the income or even a part of it every year to the principal, he will get rich; and it is equally true in regard to increasing the fertility and productiveness of the farm. Of course, I do not mean that a farmer should not sell anything; but he should aim to sell such products as carry off the least quantity of plant-food. For instance, butter carries off *nothing* of any value as manure; pork carries off scarcely anything; animals of all kinds carry off comparatively little; wheat flour carries off very little—the plant-food of a crop of wheat is nearly all in the straw, chaff, and bran."

"Your mangel-wurzels, judging from the way you have to manure them," remarks the Deacon, "must require a great deal of plant-food."

"True, Deacon, but you know that I do not sell them. They are fed to the sheep, cows, and pigs. The cows carry off nothing, for I sell nothing but the butter; the pigs carry off very little, and the sheep only from five to ten per cent. Taking leaves, roots, and bulbs, I do not think I lose, or need lose, over three per cent of the plant-food contained in the crop. And it is so with clover when fed out on the farm. Taking the roots into the account, I do not think we lose, when the crop is fed out on the farm and the manure carefully saved, over three per cent."

"This is all very well," said the Deacon. "I know, of course, if a man has \$10,000 to start with, and can invest it at compound interest and save it, he will become a rich man. But the trouble is to get the \$10,000."

"I think you and I, Deacon, were worth \$10,000 a piece when we were 20 years old."

"I was not worth \$1,000," said the Deacon.

"You mean," I replied, "that you had not one thousand dollars in cash. I don't know that I had one hundred, and yet I think, if we had only known it, you and I were worth \$10,000 each. There was that amount of capital locked up in us. The truth is, very few

people appreciate the real value of a healthy, active, industrious, energetic, sober, and intelligent man. Ten thousand dollars is a low price for him. If such a man can earn and invest at compound interest at ten per cent \$1,000 a year, he will at the end of fifty years be worth \$219,347.98."

Earning, saving, and investing money is the secret of getting rich. Developing the resources of our land, saving them, and so using them that they will produce crops that carry off little plant-food is the secret of making our farms rich. We should not let our plant-food lie idle. We should keep it moving. To do this to the best advantage is a great art and a profound science. In this country there is everything to stimulate us to advancement and improvement in agriculture. We own the land. If we can manage to secure a livelihood, and at the same time add to the fertility of our farms, we are in a fair way to get rich. And it is well worth while to make a decided effort in this direction.

There is a good prospect for good farmers. "I don't know about that," said a neighbor; "if I could sell my farm I would quit the business. And if I can't sell, I mean to rent it. As things are now, it takes all I can raise to pay my hired help."

"That is because wages have been too high, and because you do not raise enough per acre. Wages will be lower and prices higher; and if you will farm better you will make money."

"I can't see it in that light," he replied. "My wheat crop last year did not average five bushels per acre."

"It was one of the worst seasons for wheat we have had for many years."

"We have too many bad seasons."

"Well, what are you going to do about it? It is no worse for you than for others. You should not go to sea expecting nothing but fair weather. You should prepare for storms. If you had had a good crop of wheat last year, and a good crop of barley, and a good crop of potatoes, and a good crop of choice apples, you would feel richer and jollier than Vanderbilt did last October when New York Central stock was down to 79½, Western Union to 43½, and Lake Shore to 57½, and few buyers at that.

"I do not say that a farmer can always be sure of good crops. I know that such is not the case. But if you would farm better—if you would drain your land, cultivate it thoroughly, kill the weeds, make more and richer manure, you would stand a fair chance of getting good crops even in a bad season."

I wish Mr. Bliss, instead of offering prizes for the greatest yield of potatoes from a pound of seed had offered them for the largest yield per acre. The Deacon and I have just been reading the report of the committee. It is an interesting document. The Deacon seemed to think there must be some mistake. I told him I once knew a gardener who accidentally dropped a potato near a hot-bed, and it got covered with some manure and came up. It was not in the way, and so he hoed a little earth round it and let it grow. The ground was very rich, and the plant threw up a great many suckers. Every few days he pulled a little fresh earth to it, and before autumn he had a hill a good deal larger than a half barrel. He dug over a peck of potatoes from that one hill.

"What variety was it?" asked the Deacon.

"I did not ask. I saw the plant while it was growing, and have no doubt it produced an

immense crop, but I attributed it to the manure and the extra care. It never occurred to me that it proved that the variety was anything remarkable."

"I can believe a story of that kind," says the Deacon. "He got say 15 lbs. of potatoes from one potato, which may have weighed a pound. But in these premium-potato trials one man got 607 lbs. of potatoes from one pound of seed, and the lowest yield in the 20 different trials, by different people, in different parts of the country, was 250 lbs. from one pound of seed. We usually plant 6 bushels of seed per acre, and get about 120 bushels—or say 20 lbs. of potatoes to 1 lb. of seed. If we could grow 250 lbs. from 1 lb. of seed, we should get 1,500 bushels of potatoes per acre; or if we could grow 607 lbs. from 1 lb. of seed, we should grow 3,642 bushels per acre."—The Deacon laughed a quiet laugh and shrugged his shoulders, but made no further remarks.

"The experiments, Deacon," I replied, "are designed to show the wonderful vitality and productive powers of two new varieties of potatoes. We must take the facts for what they are worth. No farmer would think of planting potatoes as these were planted. We want to raise big crops per acre. These experimenters tried how much they could get from a pound of seed. They cut their pound of seed into a hundred or so pieces, with never more than one eye in a set, and frequently with less. They planted one of these hundred pieces in a hill. For anything that appears to the contrary, each hill may have occupied a square rod. If the hills were 6 feet apart, there would be 1,210 hills in an acre; and if the pound of seed planted 100 hills, as the report gives us to understand was sometimes the case, and the produce was 250 lbs., the crop would turn out about 50 bushels per acre. If it was 607 lbs., which is the largest yield reported, it would be about 120 bushels per acre. The committee say 'the hills were invariably placed a considerable distance apart, rarely less than three feet each way, and oftener further.' If they were four feet apart, there would be 2,347 hills in an acre, and if the hundred hills yielded 250 lbs., the yield per acre would be 6,837½ lbs., or a little less than 114 bushels of 60 lbs.; and the largest yield reported would be (100 : 2,347 :: 607 : 17,281), 17,281 lbs., or 288 bushels per acre."

"That looks more reasonable," says the Deacon. "I usually plant 3½ feet apart each way." This would give 3,556 hills per acre, and the smallest yield reported would be about 143 bushels per acre, and the largest about 360 bushels per acre.

I know very well that this is not doing these varieties justice. They are doubtless capable of producing much larger crops if more and larger seed had been used. And as I said before, I hope that hereafter the prizes will be offered for the largest yield per acre rather than for the largest production from the smallest quantity of seed.

A New Method of Hurdling Sheep.

Some time ago an English gentleman devised a method of irrigating grass land and a method of successfully feeding of sheep upon the enormous crops of grass he is thus enabled to grow. The mode of irrigation was described and illustrated in the *Agriculturist* for December, 1873. It will interest many of our readers to know the manner in which this enterprising Eng-

fishman fed 66 sheep for six months upon each acre of ground thus irrigated. He had constructed a quantity of hurdles of a peculiar

vents any trespassing upon the other side of them, and by using two rows of hurdles the sheep are kept in the narrow strip between

that here. The labor of attending to 400 sheep so closely fed would be at a minimum of cost. The feeding of 400 sheep a whole summer should be worth \$1.80 each at one cent a day per head, which is the usual payment for pasturing sheep in flocks for drovers. This would be equal to \$118.80 per acre. These figures would seem to leave a margin for profit even for us. They seem honest; but although figures are said to be perfectly trustworthy and truthful we have in practice so often found them to belie their general character, that we would not in this case pin our faith upon them without some experiment. Nevertheless we feel sure about the value of the hurdle and this plan of using it in many cases. Some few farmers here grow rape for late summer feed for sheep, and many thousands might well do so. For penning sheep upon rape these hurdles are very much better than the ordinary flat ones which have to be firmly set in the ground and tied together, while these are self-sustaining and instantly turned over. This great advantage should make them very acceptable to us.

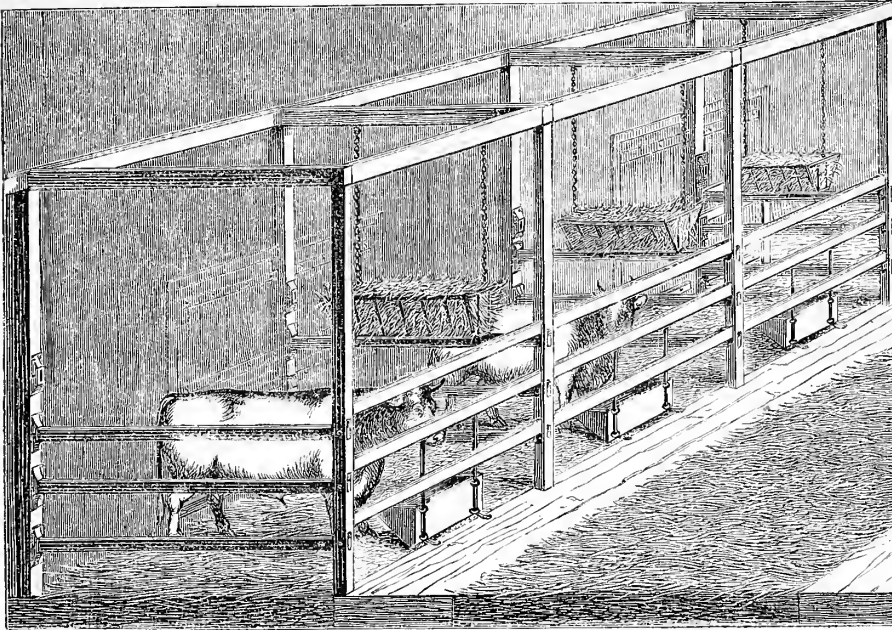

Fig. 1.—INTERIOR OF COVERED CATTLE STALLS.

Covered Stalls for Cattle.

The use of covered stalls for feeding cattle and preserving manure is becoming very general amongst the better class of English farmers. Occasionally they are made use of by farmers

description. They are 12 feet long, and are made of a stout pole bored with two series of holes 12 inches apart. Stakes six feet long are put into these holes, so that they project from them three feet on each side of the pole. One series of holes is bored in a direction at right angles to that of the other, and when the stakes are all properly placed they form a hurdle the end of which looks like the letter X. The engraving below shows how these hurdles are made and the method of using them. A row of these hurdles is placed across the field. The field in which they are used consists of six acres. A strip of 10 feet wide is thus set off upon which 400 sheep feed. They eat up all the grass upon this strip and that which they can reach by putting their heads through the hurdles. The hurdles are then turned over, exposing another strip of rather more than four feet wide at each turn. When this is fed off

them. Their droppings are therefore very evenly spread over the field, and it is very richly fertilized by them. At night the sheep are taken off and the grass is watered. The growth is one inch per day under this treatment, and when the field has been fed over, the sheep are brought back again to the starting point and commence once more to eat their way along.

As to the practicability of this method with us under our circumstances there is some question. The cost of the apparatus for irrigation is very large. The yearly interest, on the cost and

in this country with the best results. That they may be the more generally known we have prepared the accompanying engravings to show their structure. Fig. 1 shows the ground plan of a shed containing fourteen stalls, each ten feet square with a passage way in the center of four feet wide. Fig. 2 shows the elevation of the building with the arrangement of the doors. It is of two stories, the upper one being used for the storage of straw, hay, or roots or the preparation of the feed. Fig. 3 shows the interior of the building, with some of the stalls upon one side. With these views the following short description will be more readily understood. The shed here described is 70 feet long by 24 feet wide, having seven stalls upon each side. It is built of plain boards and scantling, and one of the cheapest character will answer every purpose as well as the most costly building; the shelter and preservation of the manure being the chief objects in view. There is a door at the rear of each stall divided into upper and lower halves so that the upper one may be opened for air and ventilation. There is a large door at each end of each row of stalls, and the divisions between the stalls are made of movable bars. These bars being taken away a wagon may be driven through the building from end to end for the removal

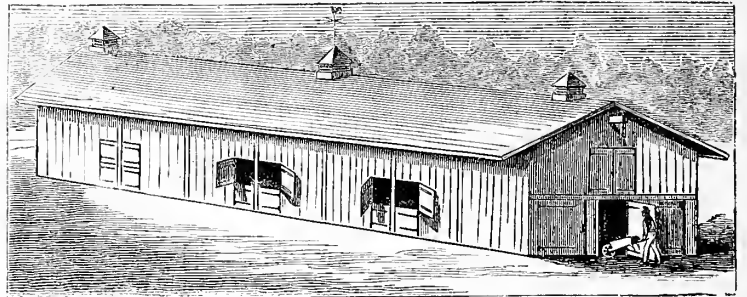
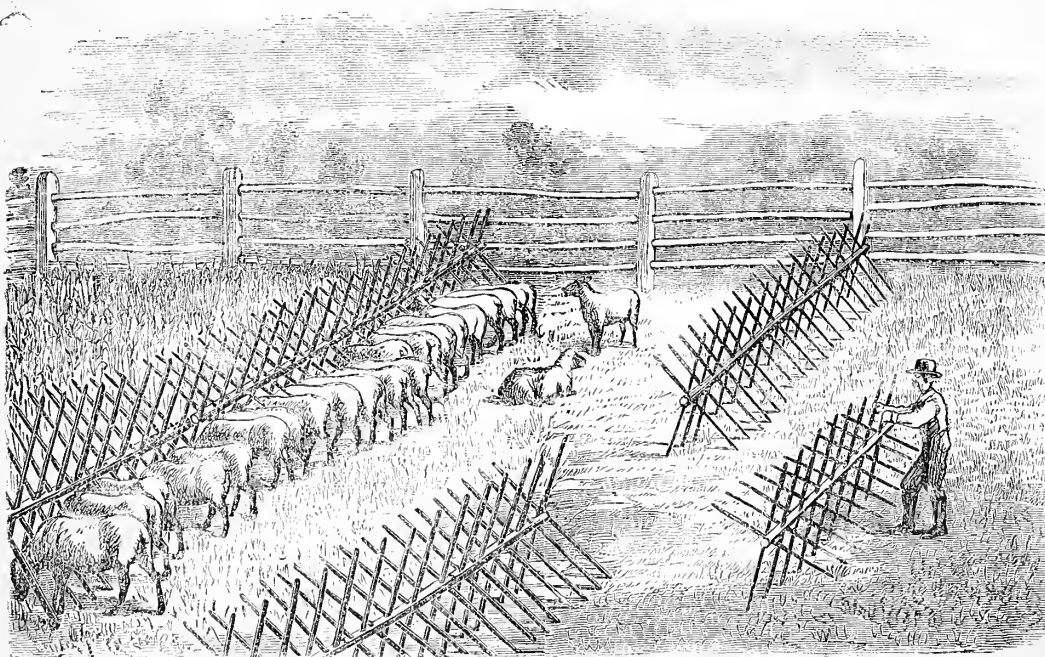

Fig. 2.—ELEVATION OF COVERED CATTLE STALLS.



SHEEP HURDLES AND MANNER OF USING THEM.

the hurdles are again turned over. The chevaux-de-frise presented by the hurdles pre-

the maintenance together, is \$57 per acre in England. It would not be much more than

taken away a wagon may be driven through the building from end to end for the removal

of the manure. The floors of the stalls are sunk three feet below the surface. Here the cattle are fed and well bedded with straw. If the straw is cut into lengths of at least three inches the manure is so much the better for it. The litter and the manure remain in the stall during the whole winter, and as they gradually accumulate and the floor rises the bars are raised. Each bar fits into sockets in the posts of the building, and is held into its place by pins. The feed trough is made to slide up and down upon iron bars as may be needed. There is also a rack slung from the roof or ceiling above, between each pair of stalls, for long straw or hay, which is given once a day to

the stock. The most appropriate and economical feed for the stock in these stalls is cut hay and meal and roots, either steamed or otherwise. The richer the feed given the richer will be the manure.

An Improved Horse-Trough.

There are a great number of horses which have the wasteful habit of throwing their feed out of the trough by means of a side jerk with the nose. This is especially the case with horses that are fed with cut feed, and it is in

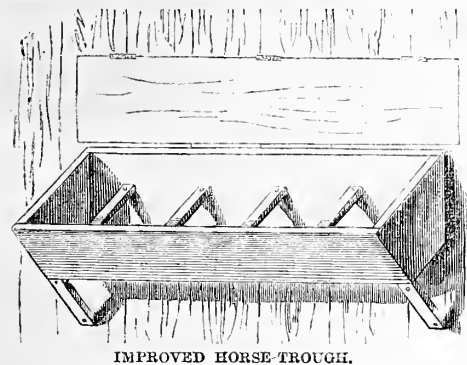

IMPROVED HORSE TROUGH.

the search for the loose meal which finds its way to the bottom of the trough that the mischief is done. We have prevented the waste by simply nailing a few bars across the feed-trough as shown in the engraving. The horse then finds it impossible to throw his feed out, and must take it as he finds it. The bars should not be more than a foot apart.

Burning Shells to Make Lime.

The engraving shows the usual method of burning shells for lime in pits or heaps. This may be done very readily in places where shells are abundant and stones for building kilns are scarce, as in localities along the bays and inlets along the coasts. In these localities shells are the only available source for a supply of lime, and this valuable fertilizer can not be procured in any other way except at great expense. To burn the shells a level spot should be made about twelve feet in diameter. A quantity of rough brush-wood is then laid down several inches in thickness, leaving four or more open draft-ways or flues from the outside to the center. Fine kindling-wood is laid

in these draft-ways. A flue of sticks, placed upon their ends, is also made in the center of the heap connecting with these draft-ways. Upon this lower layer of wood a foot in thickness of

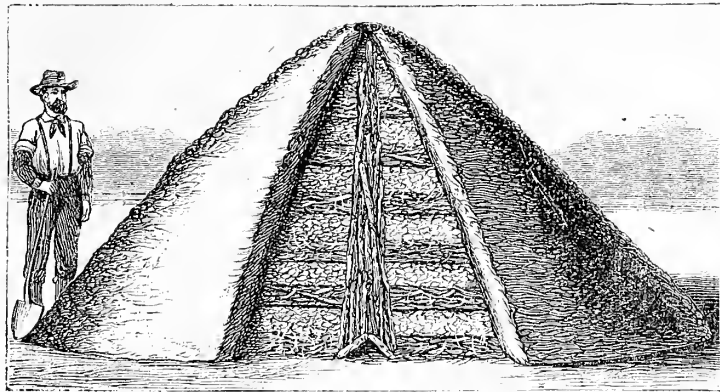

HEAPS OF SHELLS FOR BURNING.

shells is placed, then a layer of wood and then one of shells, alternating with shells and wood, and gradually drawing in the heap until a conical pile about eight feet high is made. The central flue is carried up carefully to the top as the heap is made. The heap is then covered with swamp-grass or sea-weed or sods, upon which earth is thrown and closely beaten down. The hole at the top is left open at first. Then fire is put to the bottom of the heap at each of the draft-holes, and when the fuel is well kindled the holes are closed or partly closed with flat stones or sods so as to keep the fire from burning too quickly. When the heap is all on fire a flat stone is placed over the central hole, and the drafts are very carefully watched and managed so as to keep a moderate red-heat inside the pile. A ladder should be kept at hand to reach the top of the heap when necessary. As the heap gradually settles down the cracks which will appear should be closed with fresh earth. If a large hole should happen to be made a few shovelfuls of shells should be thrown into it, a quantity of damp grass or weeds placed upon them, and covered closely with fresh earth. In three days the shells will be burned into lime.

The best way to use the shell-lime is to draw it as soon as cooled to the field where it is to be spread and deposit it in small heaps one or two rods apart each way, according to the quantity to be spread. If half a bushel is placed at each heap, and the heaps are one rod apart, there will be 80 bushels of lime per acre. If the heaps are two rods apart there will be 20 bushels per acre, and if the heaps contain one bushel there will be 40 bushels per acre.

A Calf-Feeder.

Patience is not a universal virtue, and a great deal of patience is required in teaching a calf to drink. It is not an uncommon thing to see the milk spilled by the calf, and the poor creature bawled with the empty pail by its more intelligent owner as a gentle intimation that it must not do so again. Those who would rather use a lit-

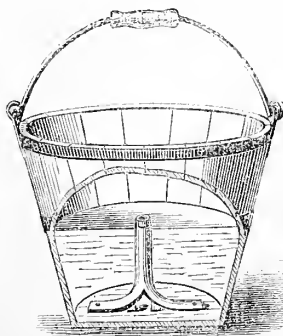

CALF-FEEDER.

tle ingenuity in place of the required patience may avail themselves of the contrivance here figured. It consists of a tube fastened to the bottom of the feeding pail so that the milk can enter the tube by the bottom and be sucked up by the calf. A piece of india-rubber tube, with a nozzle of elder-wood, from which the pith has been forced, placed in the end to prevent collapse, will answer the purpose. After the calf has had a short experience with a pail of this kind it is usually the case that it takes to drink-

ing without the use of the tube, and it may then be removed.

Protection for a Circular Saw.

The circular saw is a necessary addition to the horse-power on every well-appointed farm. Besides its use for cutting fire-wood, it can be

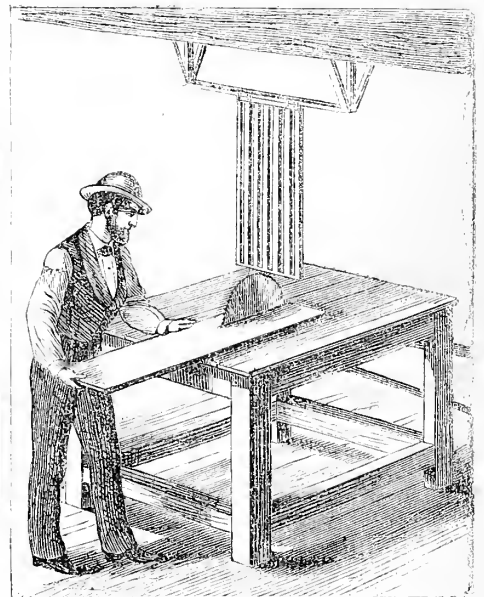

PROTECTION FOR CIRCULAR SAW.

made of great help in preparing lumber for the constant repairs and alterations which are needed. But such a saw requires to be used with caution. The table needs to be made very strongly and set very firmly. The greatest care is needed to avoid flying splinters, pieces of bark, or loose knots while the saw is in operation. The edge of a saw two feet in diameter, revolving 3,000 times a minute, moves with a velocity of 300 feet in a second, and any pieces or splinters which may be thrown over the saw moving with equal velocity, acquire force sufficient to do a serious injury should they strike any person. This danger may be avoided by hanging over the saw (from the ceiling or beam above) a frame of strips of plank made as shown in the accompanying engraving. This is better than hanging a piece of solid plank, which is sometimes done, because the plank obscures the sight, while the frame of strips does not, and the operator, being able to see between the strips, can view everything which is going on. The spaces between the strips should not be more than half an inch each in width.

A Square Harrow.

At the request of "W. B. S." we give an engraving of a square harrow jointed in the middle. It is made of 4x4 or 3x4 hard-wood timber. Four pieces 3 feet long and eight pieces 2½ feet long are required. These are mortised together, as shown in the engraving, and each mortise is secured by a wooden pin or a one-quarter inch carriage bolt. The two wings are connected by two eye-bolts in each,

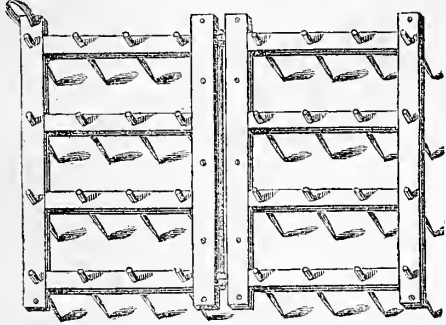

A SQUARE HARROW.

through which a long rod passes. The rod is secured by a nut at one end and a head at the other. The harrow is drawn from one corner. It contains 32 to 44 teeth of three-quarter inch square iron, each 14 inches long. For a light harrow the teeth may be of half-inch iron and the timber of 2x4. There should be a light carriage bolt put through the end of each bar to prevent it from splitting, and the teeth should be placed so that their edges will be in a line with the line of draft.

A Sheep-Rack.

In feeding sheep in winter we have found that unless the hay-rack is properly made the sheep will get their heads through the bars and wear the wool from their necks, besides filling the wool upon their backs with grass heads and clover seeds. This is a great inconvenience, and injures the sale of the wool, besides wasting some of it, which is pulled off by the bars of the rack. To prevent all these troubles we have used a rack such as is here figured. For large sheep it should be 3½ feet high at the front. The bars are only three inches apart. They should be made of ash, chestnut, or oak strips, dressed and smoothly sand-papered, and ¾ inch thick by one and a quarter wide. The front of the rack should slope backwards three

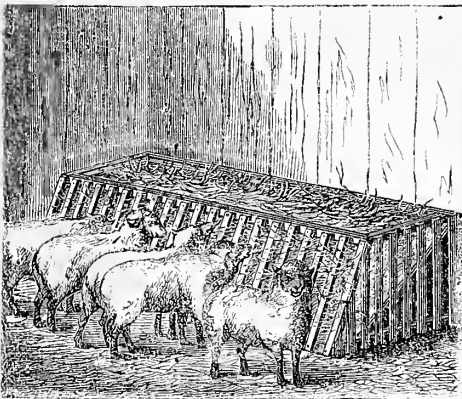

IMPROVED SHEEP-RACK.

or four inches. This prevents hay or clover dust from falling out upon the sheep's heads. At the rear of the rack sloping boards are fitted, so that as the hay is consumed it falls down to the bars at the front where the sheep can

reach it. The end of the rack should be closed with bars in the same way as the front, so that young lambs can not creep in and get lost. By want of this precaution a fine, lively young lamb will sometimes get into a tight place, where it may become chilled and die.

A Safety Drain.

Notwithstanding the healthfulness of the farmer's occupation, and the abundance of fresh air around him, he is nevertheless a victim to those diseases consequent upon the breathing of foul air and the neglect of sanitary precautions in a greater degree than any other class of people. It has come to be said, and with justice, that typhoid fever is the farmer's peculiar disease, and that scarlatina and dysentery are the prevalent diseases amongst his children. There are many good reasons for this. One frequent cause is doubtless the drainage from cesspools and manure yards into wells from the saturated ground around them; while another is the exhalation from kitchen sinks which discharge into foul drains, or from putrid places where slops are thrown in the absence of sinks. A perfectly constructed sink is an indispensable adjunct to a healthy condition of the house. A perfect water-trap should be made in every drain. The simple bend in the pipe is not sufficient, because the warm air in the kitchen during the winter season is sufficient to set an air current in motion in the drain pipe which will be strong enough to force a passage through the water contained in the bend of which the air-trap generally consists. But a perfect air-trap may be made as follows: There should be made in the pipe from the sink a bend sufficient to retain a portion of the escaping water. Beyond this another larger bend should be made, and between

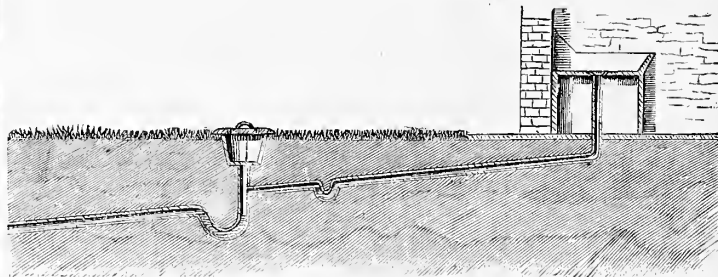

DIAGRAM OF A SAFETY DRAIN.

the two bends there should be a short pipe fitted which comes to the surface of the ground at least several feet or yards from the house. The most convenient arrangement is to fit the upper end of this pipe into the bottom of a flower-pot or a wooden box which is sunk in the earth and which is kept loosely covered. This receptacle may be filled with some disinfectant which will destroy the poisonous gas. Shavings saturated with carbolic acid or charcoal saturated with a solution of copperas would answer this purpose. This should be renewed at least every month, or more frequently if necessary. Then any foul air from the drain or the cesspool, or other final receptacle into which the drain may pass, can not possibly enter the house, but at the worst will escape into the air at a distance from it. If, however, the trap is kept supplied with a disinfectant the foul gas will be neutralized.

The above engraving represents the whole arrangement, which should be attached to every farm kitchen; in fact, it is applicable to almost every house in the country and many in towns and cities.

The Imperial Pekin Duck.

A few Imperial Ducks were imported from China last spring, and have excited a good deal of interest among the fanciers. They came from the city of Pekin, and first attracted the attention of the gentleman who imported them by their great size. They were thought to be a small kind of geese. They are very prolific, each duck laying about one hundred eggs in a season, beginning early in the spring. They are white, but it is not the snowy whiteness of the Aylesbury; the bills are yellow and the legs red. The wings are rather short, and they make as little effort to fly as Cochin or Brahma fowls. They are admirable birds for small yards, and can be kept with as little trouble as hens. Their period of incubation is twenty-five days, a little shorter than the common Mallard. We bred them this year in connection with the Rouens. They look nearly a third larger when they first come out of the shell. They have steadily kept the lead of the Rouens, and for the first five months of their history are larger and better birds. At two months old the best Pekin weighed four pounds and the best Rouen three and a half. The Pekins at four months old weigh about twelve pounds to the pair with ordinary feeding. They grow with much uniformity as to size, birds of the same age weighing very nearly alike. What size they will attain in more skillful hands, and when they reach maturity remains to be seen. They are very hardy, are quite easily raised in small inclosures without water to swim in. Water to drink seems to meet their wants quite as well as those of the chickens with which they grow up. They are undoubtedly a thoroughbred fowl and come to early maturity. About sixty birds were raised from the importer's stock—a quartette, which is

very fair success. They make a beautiful show in the brook that runs by his door. He disposed of all of his stock that he would sell long before it was mature, and not a pair probably can be bought at any price before the fall of 1874. If the introduction of this showy Chi-

nese fowl shall do for our ducks what the Asiatics have done for our hens it will mark a new era in poultry raising. *

Fish in Small Ponds.

We receive frequent inquiries, especially from correspondents in the Western States, about the practicability of raising fish in small ponds of surface water. This depends altogether upon the kind of fish it is desired to cultivate and the character of the ponds. We would not advise any one to undertake to cultivate fish of any kind in a small artificial pond such as is often made near the barn for the purpose of watering stock. A quarter-acre pond in a hollow fed only by rains, nearly dry in summer, is too small to do anything with, for pleasure or profit in fish culture. Yet on a retentive soil these small ponds may be greatly enlarged by damming so as to retain all the rains that fall in winter. If a pond of three or four acres can be made, and six to ten feet in depth, there is no difficulty in raising carp, of

which the gold-fish is a variety, and almost any of the coarser sorts of fish. Sun-fish or roach do well in such ponds if they have coarse sand or gravel in which to make their beds. The yellow perch would probably thrive in them, with brush or sticks near the shore on which to affix their spawn and to make a shelter for their young. Of course, in such a pond the number of fish that can be raised is quite limited. They begin to devour one another at a very early age, and this is the strongest characteristic of nearly all the finny tribes through life. It is their destiny to be eaten, and they seem to have no nice sense of gratitude, to reserve themselves for the palate of the culturist, but yield to the first mouth that opens. Constant feeding with animal food will abate their hunger somewhat, and leave more fish to reach adult years, but this, in old communities where such food is scarce, diminishes profits. Where springs are copious, trout can be raised to advantage in small ponds. To raise black bass successfully clear water with a gravelly or rocky bottom is needed, and the larger and deeper it is the better prospect of success.

What may be Expected of a Jersey Cow.

We receive a great many inquiries which show that the characteristics of the Jersey cow are not very well understood even among the readers of agricultural papers. One man wants to know what sort of working cattle they would make, and if the beef is as good as that of the natives. Another is going into the milk business, and wants to know if the Jerseys are the stock he should purchase. Another is near a cheese factory, and thinks the Jerseys possibly may be the best thing for him. A lady of romantic turn has bought a Jersey heifer with her first calf, and suspects she has been badly cheated because she does not get a pailful of milk at night and morning.

The Jersey is not a worker of miracles, and can no more make something out of nothing than any other breed of cattle. She is not even an extraordinary animal, and does but one thing in a superlative way. If one wants to raise working cattle the Devons are beautiful to the eye, and have been trained to the yoke for many generations. If he wants early maturity in the beeves the Shorthorns have no rivals. If he desires a large quantity of good milk for the nearest village market the Ayrshires are hard to beat. But if he wants a pet family cow, giving a small quantity of very rich milk for his own table, he may safely invest in a Jersey cow. It is so rich in cream that we should not like to repeat the statements of credible witnesses, who have milked the cows, poured the milk into the lactometer and measured the thickness of the cream, and churned and worked the butter with their own hands. Five quarts of milk have been known to make a pound of butter. Heifers with their first calves sometimes make five or six pounds of butter a week, and cows ten or twelve pounds a week. In extreme cases, nineteen pounds have been produced in a week from one Jersey cow, of course in flush feed, and with as much meal as she could digest. It is not reasonable to expect that a cow giving milk so rich in butter will give a very large quantity. The average of Jersey herds probably does not exceed eight to 12 quarts per cow daily in good pasture. The milk is very palatable, and children once accustomed to it are apt to be disgusted with the thinner fluids furnished by the milkman. The

butter made from it is of the deepest yellow, very solid and waxy, and of the richest flavor. It is unlike any other butter that comes to the table, and the initiated would not fail to detect it among a hundred samples made from the milk of other breeds. The cream is so highly colored that the milk of a single Jersey cow in a herd of a dozen natives will increase the color of all the butter made from the dairy. There is a steadily increasing demand for Jersey butter in the Boston and Philadelphia markets, where the article is best known. In the suburbs of these cities this breed is very highly appreciated, and the butter brings from 75 cents to \$1 a pound. It is quite the fashion for wealthy families living in the suburbs a part of the year to keep one or more Jersey cows.

The Jersey is valued not only for her milk, but for her esthetic qualities. She is very gentle, eats from the hand, comes readily at call, and takes kindly to petting. She is rather a graceful object upon the lawn and, unlike the deer, requires no wire fence to keep her from straying. Much attention has been paid in late years to improvement in the form and color of the Jerseys, and animals can now be found in many herds very attractive to the eye without any loss of the valuable qualities that characterize the breed. Quite as good Jerseys are now raised in this country as are imported, and we are inclined to think that our best breeders are even more careful of pedigrees and of breeding for valuable points than they are in the Isle of Jersey. They can be bought quite as cheap, and with the additional advantage of a personal knowledge of the breeder as a voucher for the authenticity of the pedigree. In the northern parts of the country the Jerseys are already acclimated, and are found to do quite as well as in their native island. They are not dainty feeders, but eat readily the vegetable refuse of the family, and appear to enjoy it quite as well as the pasture. To do their best, they want abundant feed of good quality and comfortable quarters kept reasonably clean.

Loss of Weight in Dressing Turkeys.

Farmers frequently have occasion to sell turkeys by live weight, and wish to know what is the fair relative price between live and dead weight. In turkeys dressed for the New York market, where the blood and feathers only are removed, the loss is very small. For the Eastern markets the head is cut off and the entrails are taken out. This makes a loss of nearly one-tenth in the weight. A large gobbler was recently killed weighing alive 31½ lbs. After bleeding and picking he weighed 29½ lbs., a loss of 2 lbs., or about one-fifteenth. When ready for the spit he weighed 28½ lbs.—a loss of 3½ lbs., which is very nearly one-tenth of the weight. Where the market requires the New York style of dressing, and the price is 15 cents a pound, a farmer could afford to sell at 14 cents live weight, or less, if he counted the labor of dressing anything. In the other style of dressing, if the price were 20 cents, he could sell for 18 cents, or less, live weight, without loss. Farmers who have never tested the loss of weight in dressing sometimes submit to a deduction of three or four cents a pound from the middlemen, who are interested in making this large difference. We have no means of knowing the exact cost of dressing turkeys, but half a cent a pound would probably be a large estimate. The prevailing higher price of dressed turkeys in the Eastern market

is not owing simply to the difference in the style of dressing, though this has something to do with it. A large portion of the turkeys that go to the Boston and Providence markets are of extra large size, principally of the Bronze and Narragansett breeds and their crosses, raised in Rhode Island and Eastern Connecticut, where the farmers make it a specialty. Whole flocks of young birds will dress about 12 lbs. on the average at Thanksgiving, and 14 lbs. or more at Christmas. Young cocks frequently reach 18 to 20 lbs. dressed during the winter, and adult cocks 28 to 30 lbs. These birds are prepared for the market in the nicest style, and are shipped by the ton for the holidays. They always bring extra prices.

Transportation of Cattle.

It is an undoubted fact that a large amount of suffering is inflicted upon cattle in their transportation from their feeding grounds to the Eastern markets. Money is at the bottom of this suffering, or rather, we might say, that it can not be afforded to transport cattle without it. It is also an indisputable fact that between the farmer who feeds and sells the cattle and the purchasers in the cities who consume the meat an immense part of the ultimate cost of the meat disappears. Possibly this is unavoidable under the present system, but it is not on that account any the less disagreeable to either of the parties out of whose pocket the money which disappears is taken. We are not without a well-grounded hope that this condition of things may soon be changed for the better. We not long ago inspected a consignment of 420 carcasses of beef which were slaughtered in Texas and shipped to New York, where they arrived after a journey including delays of at least ten days. The beef was excellently well preserved in the patent refrigerator cars of Mr. T. L. Rankin, of Emporia, Kansas, and Denison, Texas. This beef was sold in New York at an average price of six cents per pound. At the same time, its first cost in Texas was far more remunerative to the feeder of the cattle than it has hitherto been. Not the least pleasing consideration is that the immense amount of cruel suffering and agony incident to transportation was spared to these cattle. This is particularly exemplified by the absence of the usual extensive bruises with which the shoulders and flanks of beef cattle shipped alive are covered, and which tell a tale of great pain to the poor brutes. The success of this experiment—which will be at once repeated—tends to show that if beef can be shipped from Texas and received in New York in perfect condition, with the advantage of a gain of 50 per cent in the receipts of the feeder and a saving of 30 per cent in the outlay of the final consumer in the cities, it may also be transported from Illinois, Kentucky, Ohio, or Iowa with even greater facility and an equal gain to the parties interested. Here is a matter for Western farmers to consider. They are really but 48 to 60 hours from New York, Boston, or Philadelphia. If it is demonstrated that beef can be kept in these cars perfectly well for ten days it is still easier to keep it two to three days. The farmer will save the freight upon the offal, or 45 per cent, by shipping beef instead of cattle. If by the exercise of associated effort Western cattle can be slaughtered on the farmers' account, shipped in their own cars to their own agent in the East, and sold for their account, there will

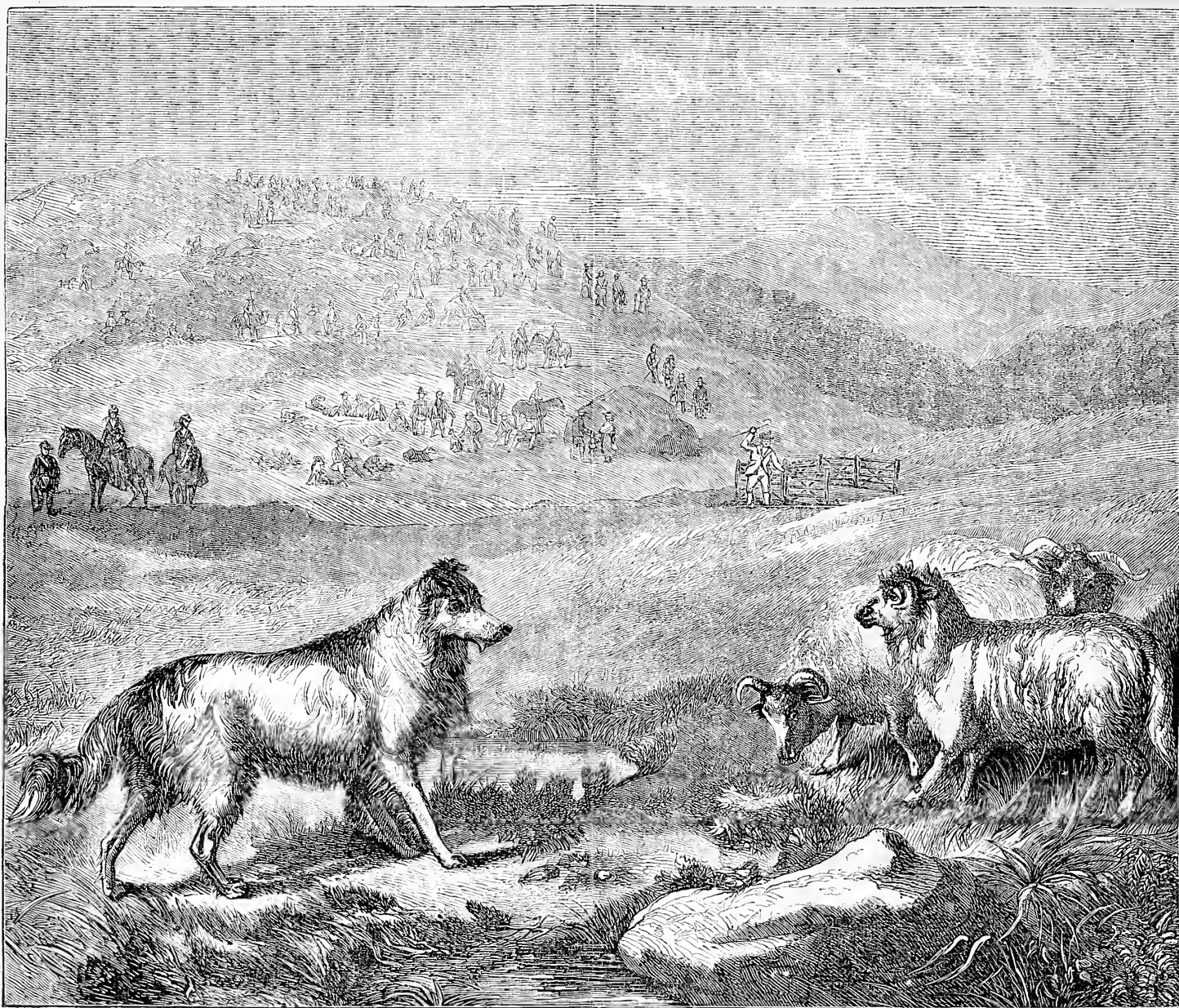

[COPYRIGHT SECURED.]

TRIAL OF SHEPHERD DOGS.

clearly be nothing lost between the producer and the consumer and nothing that can not be reasonably accounted for. We understand that the cost of these ears is \$1,100 each, and a joint-stock company of Texan cattle-men own and operate those which are now in use. The train, by express contract with four connecting railroad lines, is sent through without delay, and at the rate of thirty miles an hour upon part of the route. We commend these facts to the consideration of Western farmers.

 The Shepherd Dog.

We are indebted to the London Field for the picture of a Scotch shepherd dog at his work. It represents a field trial of dogs, for the handsome prize of fifty guineas (\$260), which was held at Bala, in Wales, in October last. The Welsh sheep are small, active, and wild, and no better animals for testing the skill of the dogs could have been selected. The dog whose portrait is here given was a pure-bred Scotch "colley," known as Sam, and his exploits certainly go far to make us believe that a dog by training and education can be made to think and reason so as to adapt himself to the vagar-

ies of a willful sheep or a whole flock of them at once. The duty the dog had to perform was to drive three sheep just released from a fold, into a pen with an entrance six feet wide at about 500 yards distant. The difficult nature of the job was increased by the excessive wildness of these small, wiry mountain sheep, which leads them to go in any direction rather than the right one, and each one to scamper off in its own chosen direction. Sam, however, was equal to the occasion, and surrounding, as it were, his three wayward sheep by rapidly executed flank movements, had them safely penned in eleven minutes and a half. This was the first heat, as it might be called. The next effort was rendered more difficult of accomplishment by sundry unlucky accidents. A flock of geese got mixed up with the sheep, or the sheep with the geese. But Sam cleverly extricated his flock from this dilemma. Then two of the sheep jumped over a stone wall, and the third bolted into the river. Sam persuaded the two to come back again, and then hauled the third out of the water by the "scruff of the neck," and soon had them all in the pen. But, by a mistake of his master, Sam lost too much time, and although his performances were by far the best in other respects he was

adjudged only the third place. The prize dog, named "Tweed," was better handled by his master, and by working around his sheep in gradually decreasing circles kept them well together, and brought them into the pen in fourteen minutes. Unfortunately for poor Sam, his master did not know quite as much as he did, consequently the fifty guineas went to Tweed, while all the honor and credit was awarded to Sam, and his portrait is now on view in both hemispheres.

The shepherd dog is not yet an American institution, because we have not as yet availed ourselves of all our excellent facilities for sheep culture. But when our mountain districts and our vast plains become the homes of flocks, then we must of necessity secure the help of this intelligent assistant. In the meantime there are thousands of places where these dogs could be made of great service in protecting our flocks from marauders and in assisting the shepherds to handle them. But, as is seen by the failure of this dog Sam, the shepherd must himself know how to command, because the dog himself obeys him implicitly, and if he does not understand his business the dog fails. Unless the man and the dog understand each other, the best trained dog is at fault.

The Garden Verbena.

The genus *Verbena* is a large one, and we have in almost all parts of the country one or more species which as a general thing are not showy. The first garden Verbenas seen in this country were brought here from Buenos Ayres in 1835 by Mr. Amory Edwards, of Elizabeth, N. J., whose account of the matter will be found in the *Agriculturist* for August, 1866, page 287. Mr. Edwards gave his plants to his brother Scotchman, Mr. Thos. Hogg, the pioneer of horticulture in New York. These Verbenas were the crimson, *V. phlogiflora*, also called *Tweediana*, and a white one, name now unknown. About this time the Verbena became popular in England, and other florists imported them, but to Mr. Hogg belongs the credit of having raised the first in America. At the present time the Verbena is one of the most popular of our garden flowers, each florist raising large numbers annually. Mr. Peter Henderson alone has sent out over a quarter of a million in one season. Those now in cultivation are by no means the original species, but others have since been introduced, and so crossed and mixed that it is difficult to trace the origin of our numerous varieties. The Verbena owes its popularity to the brilliant colors of and long continuance of its bloom, the readiness with which it may be cultivated, it adapting itself to almost any soil, the ease with which it may be propagated from cuttings, and the facility with which it forms new varieties from seed. There is probably no one plant that equals it in the range and brilliancy of its colors, from pure white through the various shades of rose and scarlet to dark maroon purple. A yellow and a black variety have not yet been produced, but they will probably come in with the blue Dahlia. Each year brings numerous new varieties of the Verbena, and the catalogues annually give us a list of new names, whether the plants are improvements upon the old ones or not. For bedding out purposes and producing striking masses of color there is no plant equal to it. The plants when established grow with great rapidity, usually attaching themselves to the soil by the roots thrown out at each joint; when a variety is not disposed to do this it may be kept low by fixing the branches to the earth by means of hooked wooden pegs or wires bent like a hair-pin. In places exposed to strong winds it is a safe pre-

caution to keep them well pegged. Cuttings of the Verbena root with the greatest ease. We have known some varieties strike roots when the bouquet which contained them was placed in water. In early summer they can be propagated to any extent from cuttings an inch long placed in saucers of sand that is kept

those of our garden varieties. The engraving of a bouquet of Verbenas is from the collection of Peter Henderson, and exhibits at about half their true size the leading varieties that are now popular. We can, of course, only show the form, and the brilliant coloring must be left to the imagination. The one at the very



GROUP OF VERBENAS.

constantly wet and exposed to the light; but for propagation in cool weather bottom heat is needed. Verbenas seed freely, and the raising of seedlings is not only an easy matter, but a very fascinating occupation, as it is likely that a packet of seeds will give a number of different forms and colors. Fair success attends the sowing of the seed in the open ground, but plants so raised are much later in coming into bloom than when the seed is started in a hot-bed. A box two or three inches deep filled with light earth forms a convenient seed-pan, and if this be placed upon the heated manure of a hot-bed the seeds germinate freely and the young plants can be set out as soon as they are large enough to handle and the danger of frost is over. In the Western and Southern States there grows a hardy perennial species of Verbena, *V. Aubletia*, which has within a few years been sent out under the incorrect name of *Verbena montana*. It makes a handsome rounded clump, and produces an abundance of flower clusters which are more elongated than

those of our garden varieties. The engraving of a bouquet of Verbenas is from the collection of Peter Henderson, and exhibits at about half their true size the leading varieties that are now popular. We can, of course, only show the form, and the brilliant coloring must be left to the imagination. The one at the very top is "Giant," a dark crimson; at the right of it is "Sable Queen," of the richest dark maroon color; opposite to this "Marmorata" is readily distinguished by its markings; just below and to the right of this is a fine white, called "White Beauty"; only a portion of a cluster of "Rosy Morn" is shown at the left of this; immediately below "White Beauty" is "Monstrosa," which has large, rich, velvety, dark purple flowers; to the left of this is "Belle Davis," scarlet; while the one at the bottom of the picture is "Mrs. Wilson," the petals beautifully marked with dark rose and white.

HORTICULTURAL STEALING.—One of our neighbors after various attempts succeeded in procuring a plant from Europe which, on account of its very tender and succulent nature, had baffled all previous attempts at importation. With great care he nursed the plant and grew it into a shapely specimen for the purpose of exhibiting it at the Pennsylvania Horticultural Society's September show. Our friend took pride in presenting a plant never before exhibited in America, but his pride was

changed to chagrin at finding when he came to remove his plant that it was despoiled of several of its branches. Some rascal could not resist the temptation to secure cuttings. It is mean enough to steal plants from one's grounds, where the grower takes it upon himself to guard them, but one who places a rare plant in an exhibition relies upon the honor of the community, and he who would mutilate a plant so shown is guilty of the meanest kind of stealing. We have no doubt the officers of the Pennsylvania Society would be very glad to make an example of this horticultural thief. The plant is of that delicate habit that he will probably not succeed in raising it; but we hope that he may in order that it may daily remind him of what a sneak thief he is. How a man must enjoy a plant obtained in such a manner!

HORTICULTURE in New Zealand is making rapid progress, but it sounds very odd to hear of a Chrysanthemum show being held in May.

An Ornamental Evergreen.

BY AL FRESKO.

I am an advocate for the planting of ornamental evergreens in suburban gardens; and as evidence of this fact, state that I have eighteen species in cultivation around my residence, and still find ample room for bedding and other plants. In selecting them I studied their adaptability (as regards ultimate growth) to each locality, as well as variety in outline, tint, and habit. Evergreens are at all times beautiful objects, giving variety during the summer months, and in winter lending a charm to the otherwise dreary and desolate garden. When flowering plants have been robbed of their jewels and the tinted autumnal leaves have passed away with the Indian summer, we have nothing left to please the eye save evergreens. In planting evergreen trees and shrubs, adaptability, hardiness, and variety in tint and outline should be studied so as to produce a pleasing effect, and thereby avoid the sameness so often visible in villa gardens, where good taste is frequently outraged by the planting of Norway spruces and Arbor Vitae in formal rows like a file of grenadiers at drill. No evergreen in my small collection has given me so much satisfaction as the "*Thuja aurea var purpurea-marginata*." This appears to be a hardy variety from seed, and I have reason to believe not generally known or duly appreciated. During a rummage in a small and neglected nursery I found several plants nearly covered by rampant growing weeds. Upon inquiring the name I received the one given above. The only satisfaction I could obtain regarding its origin was that "the plants had been purchased at a nursery." After considerable discussion the owner consented to part with two plants for a trifle, and they are now great favorites with me.

In spring the young wood becomes tinted with bright yellow, which gradually changes to a light green by the middle of August. In autumn as the maple leaves assume their beautiful hues the bright green of the Arbor Vitae gives place to a purple tint which gradually changes to a deep purple by mid-winter. At the present time (Dec. 24th) the trees are attractive objects, more especially when the sun is shining and the earth is covered with snow. I inclose a small branch, and I have to request that our good friend the editor will give his opinion regarding its value as an ornamental plant. It is a rapid grower with erect branches like the old Chinese Arbor Vitae. With regard to its hardiness I need but refer to the fact that my largest specimen occupies a very exposed situation, and last winter escaped uninjured, but its next door neighbor, the *Thuja borealis*, was nearly destroyed by the frost, and is lingering out a miserable existence.

[The specimens sent by our correspondent, who lives a short distance north of Philadelphia, are certainly very marked and distinct, and apparently a variety of the Chinese Arbor Vitae (*Biota*) rather than a *Thuja*. We do not find the name in any European or American catalogue at hand. It is certainly deserving of propagation.—Ed.]

The Cultivation of Currants.

We were not aware, until a recent visit to Green's Farms in Connecticut, that the cultivation of the currant filled so large a place among the small fruits. Here it is made a specialty by several of the fruit-growers, and is found to

pay better than any other of the small fruits. The varieties relied upon for the main crop are the Versailles and the Cherry. The plants are grown from cuttings. These are taken from the present year's growth, cut into pieces six inches long, and planted in drills about 16 inches apart and four inches apart in the drill. The soil is made rich, kept clean by frequent cultivation, and these cuttings make strong roots and throw up a stem from one to two feet high the first season. A part of the profit of the business lies in the sales of cuttings and bushes, which are sold at wholesale, the cuttings at \$3 per M., and the plants at \$30 per M. In making a plantation, the young plants are set in rows five feet apart and four feet in the row. The plants are set in rich soil, and kept clean by frequent cultivation through the entire season. They are allowed to throw out side-shoots and to grow in the bush form. They receive no trimming except the annual cutting back for the supply of wood for the market. Some of the plantations are made in the pear orchard, in line with the trees and in rows between; and where the ground is rich enough they bear quite abundantly in the shade. A small crop is looked for the third year. A full crop is from one to two tons to the acre, which brings three or four hundred dollars, according to the state of the market. The demand for the wood and plants among nurserymen is so lively, that these pay quite as well as the fruit. The chief enemies are the currant-worm and the borer. The worm is easily destroyed by the timely application of white hellebore. No time is lost in using this remedy when the enemy makes its appearance. Carbolic soap is also used with good results, and is a much cheaper remedy. About a pound is dissolved in five gallons of water, and the liquid is applied by a portable force-pump. Every worm is destroyed that the liquid touches. The shoots in which the borer makes his appearance are immediately cut away, and these remedies keep the plantations remarkably clean and thrifty. The sales from three acres on one of the fruit farms was five and a half tons, at an average price of twelve and a half cents a pound, net, or \$1375. They are packed in nice fruit boxes and sent to the New York and Boston markets. The fertilizers mostly relied upon after the thorough preparation of the soil are bone-dust, superphosphate of lime, and leached ashes. These are not applied in very large quantities. Much dependence is placed upon thorough cultivation and the timely application of remedies for insects. Some of these plantations have been in bearing for ten years, and are apparently in as good condition as ever. By the removal of old wood and the application of fertilizers they may be indefinitely continued. It is found to be very much less trouble to take care of currants than of strawberries; they are more easily picked, reach market in good condition, and keep better. The demand for them is quite rapidly increasing. It is a popular crop with the growers and the sugar dealers.

CONNECTICUT.

Notes from the Pines.

THE BALANCE OF THINGS is beautifully observed in nature. One of the most charming as well as instructive books I ever read was one by Dumas and Boussingault, the translated title of which reads, "The Physical Balance of Organic Nature." A translation of it was published in this country many years ago, and it is

one of the works which ought always to be kept in print. It shows in the most graphic manner the relations of plants and animals to one another and of both to the earth and the air. In the natural state of things the balance between plant and animal life, and the relations both have upon the earth upon which they live and the air which surrounds them, are most admirably adjusted, as are the effects of the carnivorous animals upon those which live upon vegetables. In our cultivation we break up the natural balance. We raise an excess of certain plants, and the insects that live upon such plants increase to a wonderful extent; we kill off insect-eating birds, and complain that insects destroy our crops. We destroy every snake we meet and shoot every owl upon sight, and look about for remedies for trees and shrubs that have been gnawed by mice and rabbits. In our cultivation we have undertaken to supplant nature in producing better crops of better plants than would naturally grow, and we must accept the rest as the natural consequence. We put thousands of plants all of one kind in a field, and we must expect that the insects that feed upon these plants will congregate there, and if we are so foolish as to kill snakes it is only a natural consequence that mice abound. This remembrance of the excellent work of Dumas and Boussingault was brought up by my attempt to cultivate some choice

EXOTIC AQUATIC PLANTS in a tank in my greenhouse. I had planted out the beautiful New Holland *Aponogeton distachyum*, *Limncharis Humboldtii* from Central America, the blue Water-lily, *Nymphaea caerulea*, from Egypt, and other choice things. The plants grew finely, and some were coming into bloom, when I discovered, to my dismay, that the water was alive with "wrigglers," as the larvæ of the mosquito are called. The plants were very desirable, but the larvæ, however interesting they might be as animals presenting the remarkable phenomenon of breathing through their tails, were so many torments in prospect. I had complied with a part of the conditions of a natural pond. I had my plants, soil, and water. We are accustomed to think that mosquitoes are of no use. This is a mistake. They play an important part in preserving the balance of nature. It is not the sole mission of this most useful insect to disturb one's sleep and to inflict unpleasant stings. These are only incidents in the generally beneficial career of the whole race of mosquitoes. Possibly one out of ten thousand mosquitoes reaches perfection and seeks human society, while 9,999 before they emerge from the state of wrigglers fulfill their destiny as food for fishes. Why, one man in the State of New York raises wrigglers by the quart as the best possible food for his young trout. In my case there was but one remedy, and that was

FISH.—So I made a call upon Mr. Greenwood, the dealer in aquaria in College Place, who fitted me out with some sticklebaeks and other small fry, which at once gorged themselves on "wrigglers," and in a short time cleared them out entirely. In some city, Boston I think it was, the water suddenly became bad and undrinkable. An investigation showed that the trouble was due to minute aquatic animals, and that the fish of all kinds were carefully kept out of the reservoirs by means of fine gratings. Fish were admitted, and the balance of nature being restored the trouble ceased. Among

WINTER-BLOOMING PELARGONIUMS or Gera-

niums the variety called Master Christine is to be especially commended. Last spring Mr. Chitty, of Bellevue Nursery, Paterson, N. J., sent me this, among other novelties in bedding Geraniums. The plant bloomed in the border all summer; when cold weather approached the plant was taken up, severely cut back and potted, and the cuttings put in a propagating box. The old plant soon recovered, and has flowered abundantly, and the rooted cuttings, though only two inches high, are showing flower-buds. The flowers are of good shape, and of an unusual color, being of a bright, lively, and rather dark pink. Another good winter-bloomer is

JEAN SISLEY.—It is scarcely possible that we shall have a more intense scarlet than this presents; it is perfectly dazzling, and when we add that the flower is almost perfect in shape we may regard this as the best of its class. I believe that last winter I called attention to the great value of the

DOUBLE CHINESE PRIMROSE as a window plant. If the plants are procured before they have been subjected to the heat and atmosphere of a greenhouse, and allowed to come on gradually in the sitting-room window, they will bloom on all winter in the most satisfactory manner. But it will be useless to bring plants that have been forced at all into window culture; the leaves will fade, and the flowers will blast in the bud, and be uncomfortable subjects altogether. This fall Mr. John Saul sent me his new double white, "Mrs. John Saul." My plant is a small one, but it has flowered enough to show its great superiority over the common double white. Not only are the flowers more double, but the petals are beautifully fringed, and they have just the slightest possible tinge of pink, a shade so delicate that it can only be seen when contrasted with a pure white flower. It is a most valuable addition to our winter-blooming plants.

PROPAGATING ECHEVERIAS.—When Echeverias like *E. secunda glauca* get a long stem they should be cut off and the rosette of leaves put in sand to root. This I did with a lot, and intended to set out the stumps for them to grow new shoots. Not being ready to plant them at once I put them in a flower-pot and covered them with damp moss and set near the hot-water pipes. Two or three weeks after I took them out to plant, and found young shoots had started in the greatest abundance, apparently many more than would have come had they been planted in the ordinary way.

Special Fertilizers for Particular Plants.

BY PETER HENDERSON.

A man called at my office last spring with some dozen bottles as samples of special manures, indispensable, he said, as fertilizers for certain kinds of plants. He had those with him that he claimed to be specially prepared for cabbage, corn, potatoes, wheat, grass, lawns, beets, etc., etc. He even invaded Flora's realm, and declared that his nostrum for roses was a specific for any languid capers of this sometimes rather coquettish queen of flowers. His own arguments, which were rather plausible and glibly uttered, were backed up by numerous certificates—authentic, I have no doubt—where his "potato fertilizer" had worked wonders with some, with others his "corn manure" had been of undoubted benefit, and so on all through the list.

Now, I have no reason to say that the vendor of these fertilizers was a quack, except the broad fact, gathered from an experience of thirty years, that has shown me that it makes but little difference with what fertilizer a crop is treated provided the soil is properly pulverized and the fertilizer applied in proper proportions according to its strength. Had all his separate kinds of fertilizers been taken from the same bag (provided that bag contained a good article of bone-dust or guano) the result to his patrons would have been the same, whether he had used it on one or all of the crops that he had special prescriptions for.

There are few market gardeners in the vicinity of New York but who have at one time or another been obliged to take anything they could get for fertilizing purposes, and the difference has never been perceptible when manure from horse stables or cow stables has been applied, or when \$100 per acre of bone-dust or Peruvian guano has been expended, and these all are used on a dozen different crops without any discrimination. Agricultural chemistry may be all very well in some respects, but if it gets down to such hair-splitting niceties as to analyse scores of special plants, and tell us that we must feed each with just such food as these parts show it to be composed of, then our common sense, born of practical experience, must scout and ridicule such nonsense.

Plants, like animals, are not so much kept in good health by the special kind of food given as by the proper quantity and the conditions surrounding the individual when the food is received, and what proper temperature and pulverization of soil may be to the plant, air and exercise and also proper temperature are the corresponding conditions necessary for healthy animal life. Who will say that the beef-fed English laborer is in any way the physical superior of the Irishman or Scotchman whose daily food has been only oat-meal and potatoes? You get usually fine and nearly equal development in each case, but it is a condition due to a natural use of the muscles in the open air in an exhilarating climate rather than to anything special in the food. It would be quite as reasonable to tell us that a special food, chemically considered, is necessary for each class of our domestic animals as for our domestic plants, and none but the veriest charlatan or ignoramus will do either.

Fruit Growing in Utah.

Most people who visit Utah territory are surprised to see the progress already made in the cultivation of fruit. Standing upon the roof of the tabernacle which overlooks the dwellings and gardens of the Salt Lake City, one sees in every direction fine ornamental trees in the streets, and apples, pears, peaches, plums, apricots, and cherries in the gardens. Few cities or rural villages in the East are as well supplied with the large and small fruits. The city was laid out on a liberal scale, and the building lots are large enough to admit of a garden and orchard for every family. The fresh, virgin soil, the bright sunny skies, the absence of insects, and the timely irrigation with good cultivation are the causes of this almost uniform success in the growing of fruits. The grounds of W. Jennings in the heart of the city are on a large scale, and more neatly kept than many others, but the fruits are no fairer than we saw in other gardens and

in the market. Entering the gate here we see a beautiful circular lawn in front of the dwelling, closely shaven, with a fountain kept constantly playing in the center. There is a smooth, concrete walk, bordered with a great variety of flowers on either side leading to the house. To the left we pass into the fruit garden and orchard. The walks here are bordered with raspberries, gooseberries, red currants, and a native black currant of fine quality. We do not remember ever to have before seen so large gooseberries and raspberries. In a sunny spot is the vegetable garden with all the variety of products usually grown for the table. Further on are the apple and pear trees, and the ground is strewn with the fallen fruit. The apricot trees surprise all beholders. The limbs are bending with the golden fruit, which is now just ripening. There is not a mark of the *Cureulio* or any other insect upon the skin. And this fruit is so abundant that it retails in the markets for a dollar a bushel. Grapes are not always a sure crop here, but last year, though retarded by late frosts, they were likely to ripen. Strawberries grow in the greatest abundance. Some of these trees have a tinge of yellow upon the foliage and look diseased. This is attributed by some to the alkaline soil upon which they are planted. It does not seem to be an indication of disease, for we were informed that often the trees which are yellow one season have abundant fruit the next. Other cultivators rival Mr. Jennings in the quality of their fruit, though few equal him in the exquisite taste of his ornamental grounds. One gentleman informed us that a young apple tree nine inches through at the butt had produced an average of twenty-five bushels annually for three years in succession. He had a peach orchard which had yielded five hundred bushels to the acre. At a public reception given at the city hall there was a display of fruits—peaches, pears, apples, grapes, and apricots—that would have done credit to any horticultural exhibition in the land. Salt Lake City being first settled has finer gardens and orchards than other portions of the territory, but we saw at Ogden, American Fork, the villages in Jordan Valley, and other places, indications of the same careful attention to fruit growing. The houses are embowered in trees, and the trees, especially the apricots, are loaded with fruit.

The Japan Pea.

The Southern seedsmen have advertised and Southern journals have had articles in relation to the Japan Pea. As we make it a point to try all the new things that we can get hold of, we last spring obtained from Mark W. Johnson, dealer in seeds and agricultural implements, Atlanta, Ga., a sample of these peas, among other Southern seeds most courteously furnished. We sowed these peas with twenty-three other kinds of cow or stock peas. Not being aware of their bushy character, we sowed them too near together, and for this reason probably they failed to ripen. This fall we have received a sample of the same pea from L. L. Osment, Cleveland, Tenn., who says they are "unsurpassed for table use." Being in this manner claimed as a garden product we are warranted in the crowded state of the agricultural columns in placing them in the horticultural department of the paper. The seed is about the size of a Daniel O'Rourke pea, irre-

gularly globular, and without the conspicuous scar that marks the attachment to the pod; the surface is shining and of a greenish yellow color. The plant grows to the height of three or four feet, and is hairy in all its parts; it branches freely, and should have space for its proper de-

From the manner in which the pods set upon ours we should judge the yield would be very large. This pea is deserving the attention of cultivators as a fodder crop and for plowing in as a fertilizer. As to what the pea is botanically we are not quite sure; it does not belong

finding a hastate one. This plant grows from 4 to 6 feet high, with square and usually purple stems. The leaves vary considerably in shape; the engraving shows a deeply lobed lower one. The numerous flower spikes are 3 to 6 inches long, and clustered at the top of



THE "JAPAN PEA."



BLUE VERVAIN.—(*Verbena hastata*.)

velopment. The leaves are three-foliolate, upon very long stalks. The flowers are very minute, yellowish, and borne upon axillary racemes, which are sometimes short and again much elongated. The pods, of the shape shown in the engraving, are flattened and two to four-seeded. As to the horticultural value of the pea we are unable to give an opinion, as ours did not become sufficiently matured before frost. Mr. Osment's statement we have quoted above. Mr. Johnson, who sent us the seed, wrote, "not desirable for table use." Remembering to have seen the same thing some years ago in the garden of a friend near Boston we wrote to him for his experience. He writes: "They may be delicious to the celestial palate, but my wife found them hard to cook and I found them hard to eat—never getting soft no matter how long they were boiled." Thus far we think the weight of evidence is against their utility as a table vegetable. As an agricultural crop they are highly promising, at least for localities where the seasons are sufficiently long to mature them. Mr. Johnson speaks highly of the wonderfully prolific character of the pea, and its excellence as a food for stock. It is so much esteemed in some quarters that it has received the rather extravagant name of "Southern Relief Pea." Mr. Osment claims it to have produced 200 bushels to the acre.

to the proper Pea (*Pisum*), but is very near the Chinese Soy Pea, and it is probably a form of that or a closely related species. The Soy Pea (formerly *Soja hispida*, but now *Glycine Soja*) is cultivated in China, Japan, and other parts of the east, and is used to make the sauce called Soy, which was formerly more used than at present. We should be glad to hear in relation to this plant from our friends, especially in the Southern States, who have tried it under circumstances favorable to its proper development.

The Blue Vervain.

In an article upon the garden Verbena, printed on another page, it is stated that we have several native species. They are generally so unlike the cultivated ones in aspect that at first sight one would not suspect them to be closely related, much less to belong to the same genus. Our most common species have their flowers, which are small and not showy, disposed in long and slender spikes, and the plants themselves are mostly erect and robust. The species here figured is *Verbena hastata*; the specific name refers to its halberd-shaped or hastate leaves, but it was unfortunately chosen as leaves of this kind are not a constant character of the plant, and one may sometimes look in vain over a number of plants before

the stem; they are densely covered with small bluish-purple flowers, which gradually open from below upwards. A species considerably resembling this in general appearance is the Nettle-leaved Vervain, *V. urticifolia*, which has more slender spikes with white flowers. Both these plants are very common in waste places, along road-sides, and in neglected fields, and may be regarded as weeds, though not very aggressive ones. The name Verbena is the Latin for some sacred herb, and its application to the plants now known by the name is not obvious. The name Vervain is from the French *Verveine*.

THE AGRICULTURIST STRAWBERRY.—We met this old acquaintance recently at Westport, Ct., in the strawberry field of A. S. Nash. November 3d we picked several stalks loaded with the ripe and green fruit, and many of the vines were in blossom. The vines had been mulched with sea-weed during the summer, and were looking remarkably clean and thrifty. The fruit at this untimely season is probably owing to the remarkable drouth in July, and to the frequent fall rains which the mulch has retained; sea-weed and salt hay take the place of straw as a mulch along the shore and answer equally well. This makes an important saving when straw is worth twenty dollars a ton, as it is at the East the present season,

THE HOUSEHOLD.

(For other Household Items, see "Basket" pages.)

Supports for Shovel and Tongs.

The fire-sets as they are sold at the furnishing stores include shovel, tongs, poker, and a stand to hold them. Figure 1 shows one of the common forms of these stands, which is of cast-iron bronzed; others are made more costly in style and material, but essentially similar in form. The base is made heavy enough to prevent the affair from overturning readily, and is usually dished on the upper side to hold the ashes that may drop from the irons as they are set up in place. Such an affair is not only a help to neatness, but is convenient in keeping the utensils always in one place. For an open wood-fire a similar convenience can be made in rustic work, as shown in figure 2, by any one who is ingenious in making such things. In a support of this kind the base should be made as a shallow box to contain stones or pieces of old

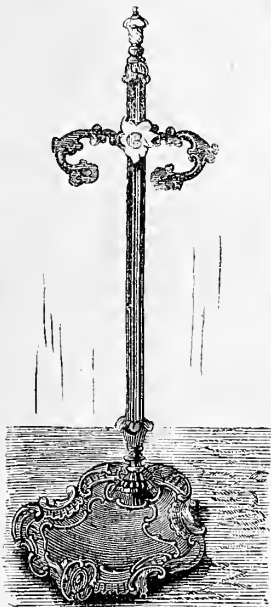

Fig. 1.—IRON SUPPORT.

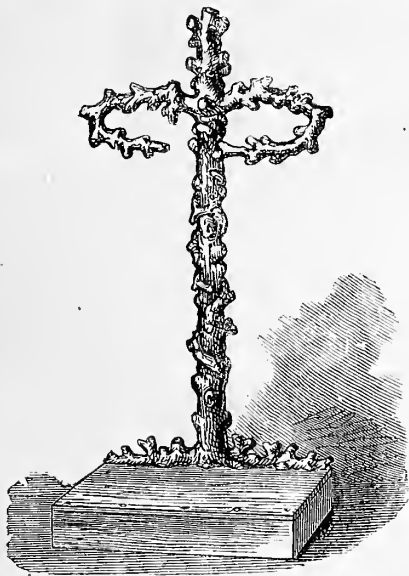

Fig. 2.—RUSTIC SUPPORT.

iron in order to give sufficient weight and stability. The base may be stained with umber and varnished, or covered with oil-cloth with a piece of zinc upon the upper side for the irons to rest upon.

Home Topics.

BY FAITH ROCHESTER.

ANOTHER RECIPE-BOOK.—This time it is the work of that great luminary in the realm of gastronomy, Professor Pierre Blot himself! The book is entitled "What to Eat and How to Cook it." I was delighted to get hold of this book at last, and expected to learn much from it. I am glad to have looked it through, and to have gained

a clearer idea of what it does *not* teach as well as of what it does.

I read the preface first, as is my custom, and was pleased to hear Professor Blot say that "no matter how inexperienced some of our housekeeping readers may be, by carefully following our directions they will be able to live as well and as economically as possible, and also serve a dinner in as orderly a manner as any steward could do." Is not that promising a great deal?

I was amused also to have him add: "It will not only be easy to order a suitable dinner at all times, but also a breakfast, lunch, or supper; any housekeeper may superintend her culinary department and direct her cook, making proper observations whenever necessary without the least trouble."

"Without the least trouble!" "Any housekeeper!" Only think what a godsend such a book must be. But Professor Blot never even thought of the various complications of American housekeeping, of the inadequate contrivances and appliances of most of our kitchens, of the poor and unreliable quality of our hired kitchen service; and how *could* he have the most faint idea of the nerve strain which a modern mother of young children suffers who earnestly tries to steer between the Scylla and Charybdis of a poorly regulated *cuisine* and neglect in the department of child culture?

That well-meaning French missionary to American heathen only directs the preparation of a meal. His assistant, a skilled French cook, carries out his directions, with the aid of a scullion to do all the rougher work of preparation and cleaning up. So, my sister American housekeepers, we must let the worthy Professor go on groaning over our barbaric food and habits of cooking until we too can have our French cooks and scullions—to say nothing of the indispensable parsley and bay-leaf that go into nearly every dish concocted by him. Gail Hamilton says (and she was one of his pupils a few years ago when he lectured in Eastern cities) that "Professor Blot puts broth into everything." It would be easier for some of us to find or make the broth than the parsley, it seems. I have inquired diligently in a Western city of over 30,000 inhabitants for parsley in some form, but without success so far. I do not wish to say that it can not be found here, and that such a large body of American citizens are deprived of its saving virtue, for it may only be the case that I have not yet found the corner where it is kept. I particularly wished to learn all about seasonings from Professor Blot, but I have not been enlightened to the extent I desired. He says: "Seasoning is the most difficult part in the art of cooking: to be able to judge what kind of spices can be used to season such and such a dish; to what extent all the spices used agree together, and what taste and flavors they will give the object with which they are cooked; for if not properly used they may just as likely destroy the taste and flavor of the object as improve it. Some dishes require high and much seasonings, others just the contrary. With a good fire and a good spit it is not necessary to be a cook to roast a piece well, but the cook is indispensable to mix the gravy or sauce with the proper seasonings." Then why could not Professor Blot have told us distinctly just what seasonings do take kindly to each other in all cases?

Masculine critics have a way of supposing that the inferior cooking done in our private kitchens is owing chiefly to our lack of exactness in following our recipes. They can not realize how difficult it is for many of us to have constantly on hand such a variety of materials as Professor Blot directs for nearly all his dishes. It does not occur to them that scarcely one housekeeper in a hundred has suitable scales and measures for accurate measurement, and nine mothers out of ten (at present the housekeepers are usually mothers) can not think of weighing out their ounces and half pounds of butter and sugar with babies pulling at their gowns, while it is so much easier to toss into the mess that is to be mixed or cooked "a piece of butter as big as a lump of chalk" or "as much as you would get on the table at one time." The cooks must be free from child care and the mothers from

housekeeping before ever cookery or child nurture can be properly carried on.

Professor Blot never uses savory for seasoning. He utters his protest against it, and says that other excellent cooks agree with him. I saw no mention of marjoram in his book, which Hepzibah Brown had not read before Mr. Hale wrote the story of her Christmas turkeys, I presume. She insisted that all of her turkeys should be stuffed with pounded cracker and marjoram. You will find over and over in Professor Blot's recipes this combination: "a sprig of parsley, one of thyme, a bay-leaf," probably "one or two white onions with a clove stuck in each," and very likely "a clove of garlic" and two or four leeks in addition. I do not doubt that it is of the greatest importance to use seasonings in proper combinations when they are used at all, but it is quite possible to cook well and omit these spices altogether if the materials are good and wholesome in themselves.

Since reading Professor Blot's book I perceive that I am much more interested in cookery as a science than as an art; not because I despise the art, but because I distrust all art that has not a firm basis of true science. I can not believe that our physical culture (and all our higher culture depends upon physical culture as a basis) demands that more attention be given to the pleasing of the palate by the mingling of spices and flavors than to the selection of wholesome materials, such use of heat and water, etc., in the cooking as makes the object cooked yield its own best flavors and its greatest nutriment to our requirements, and the judicious selection of such variety and combinations of food at each meal as tends most to keep our bodies in health and our souls untroubled by our bodies' complaints. It is highly important that food should be made palatable as well as nourishing. The stomach refuses to do its best work in helping to make good blood of food, if that food comes into the stomach unrecommended by the nerves of taste. But there are flavors most delicate and delicious stored away in the fruits and vegetables and meats and grains themselves, "each after its kind," and a sort of culinary injustice is done, it seems to me, when the cooking is in carelessness of those flavors and the main dependence placed upon combinations of spices. However, I don't know much about it, I am free to confess; but at present my hope for a true art of cookery turns more toward earnest investigating physiologists and experimenters in vital chemistry than to the conventional decrees of French "artists" in gastronomy.

A GOOD BOOK FOR PARENTS.—I have been earnestly requested by a friend to send her immediate notice of any book I find or hear of which will help her to understand her children's needs and her own motherly duties toward them. So, while I was lately reading Herbert Spenser's work on "Education," I kept longing for a chance to talk over its suggestions with my friend. I commend this excellent book to every thoughtful parent. It comprises four lengthy essays, previously published in English magazines, upon the following topics: What knowledge is of most worth; Intellectual Education; Moral Education; Physical Education. I was surprised and delighted to find the whole so plain and so practical, and so particularly adapted to parents. I do not like to own books and have the care of them (except a few for very frequent reference) unless I can have the privilege of lending them to those who appreciate them; but this is one of the books that I must surely buy and write my name in and keep circulating as fast as possible. I took it from a public library, where other good things are in store for me. Bless the public libraries!

THE LITTLE PAINT BOXES.—Our little boy had a fifteen-cent paint-box when he was about three years old, and took some pleasure in its use, but the colors were soon scattered and lost. When a new book—"Reading without Tears"—was brought home for his use, some time in September, I promised him some new paints as soon as he had read through the first part of the book. His

progress in reading was all that I could reasonably require, but I grew tired of waiting for the new paints. I grew ashamed too of holding out any such motive for the reading lessons, since the little fellow was really desirous of learning to read, and I was unwilling to have him read when he was tired or unwell or very much interested in other things. So I asked to have three good cakes of water-colors brought home—the three primary colors, red, blue, and yellow. When papa gave them to me he said: "I wonder if I have not done a foolish thing in buying just three small colors at twenty-five cents apiece. I had several paint-boxes in my childhood, and took a great deal of pleasure with them, but all together did not cost so much as these three colors."

I had some doubts myself, and do not feel sure now that our course was the best under all circumstances, but it does not seem to have been bad. A fifteen-cent box of colors was bought for the little sister at the same time. When I showed the children these treasures next day I think they both thought the cheap box preferable because there were more colors. But after I had found them some prints to color, I took a broken dinner plate for a palette and showed the little boy what a variety of colors we could make from his three primary colors. With blue and yellow we made green, more or less yellowish or bluish. With red and yellow we made orange, and with red and blue we made purple. Then we united the three colors in different proportions and made various browns and grays. This done, I laid the nice cakes of color away, leaving him colors enough on the plate to last a day or two. I taught him to put the colors on thin (or with considerable water) so as to show the shading of the engraving through the color. Our old *Agriculturists* are growing gay under the little brushes and colors, and the children have decided now that when they grow up they will be artists! Every afternoon (with some unavoidable exceptions) they spend an hour or two—all the time that they can get between the wiping of the dinner dishes and "chore time"—in the happiest employment of the day, painting. For a few days baby patiently tried to satisfy her longings after art by assuring herself, "Whou I get bigger I may paint too," but she didn't get bigger fast enough, and at last she would keep shoving a chair to the table, climbing up, and meddling with the colors and with the water cups. So now she has an old saucer with some gay color ground off upon it, a piece of newspaper to daub, and one of mamma's old long-handled oil-paint brushes to work with.

I have a chance to watch the development of art in various stages. Miss Two-Years delights most in making pretty-colored water in her little cup by frequent rinsing of the brush. Miss Four-Years likes to put bright colors on the pictures, without much regard to fitness or much care about outlines. The boy of seven years tries, in his way, to match the colors of nature and to put the colors on so as to improve the picture. The improvement is sometimes doubtful, but of course I never say so.

DRAWING AND PAINTING.—I feel pretty sure that coloring comes naturally before outlining, but I do not know of any systems of art culture where this course is followed. I had felt that the kindergarten course is wrong somehow in its drawing lessons, for I do not believe that any children will naturally take pleasure in practicing on little straight, unmeaning lines. I was delighted to find that Herbert Spencer had thought the same before me. He thinks that the use of colors should be allowed children, the coloring of pictures already outlined and shaded, as in prints, before any attempt is made to teach drawing. I see now that the desire to sketch pictures of his own to color begins to crop out in our little boy, and one or two ludicrous attempts have been made, with great pleasure to the young artist. I made a few efforts some time ago to interest him in the kindergarten drawing lessons, but it was tiresome to us both, and I concluded that the painting which he did enjoy was better practice in that very direction of drawing than such arbitrary making of unmeaning lines.

MOLASSES CAKE.—Marion Harland gives a recipe for *Sponge Gingerbread without Eggs*, which gives good satisfaction to those who try it:

"Five cups of flour; one heaping table-spoonful butter; one cup molasses; one cup sugar; one cup milk (sour is best); two tea-spoonfuls saleratus, not soda, dissolved in hot water; two tea-spoonfuls ginger; one tea-spoonful cinnamon. Mix the molasses, sugar, butter, and spice together; warm them slightly, and beat until they are lighter in color by several degrees than when you began. Add the milk, then the soda, and, having mixed all well, put in the flour. Beat very hard five minutes, and bake in broad shallow pans or in *pâté*-tins. Half a pound of seeded raisins cut in pieces will be a pleasant addition."

This recipe is given exactly as in "Common Sense." We are told that "sour milk is best." It must be decidedly better than sweet milk when so much alkali is used. With sweet milk alone what becomes of all that saleratus? There is an acid in the molasses, and soda mixed with it sets it foaming; but two tea-spoonfuls of alkali seem quite too much for one cup of molasses. The soda which is not met and neutralized by the proper amount of acid must unite with the grease in the combination to produce soap. I have been treated to molasses cake before now which was more suggestive of soap than of anything else. Soapy biscuit is also manufactured by some cooks who disregard the laws of chemistry. I have made this sponge gingerbread with sweet milk, adding a small table-spoonful of vinegar to the other ingredients. I always use soda, in spite of the prohibition.

What Shall we Have for Breakfast?

[Last month it was stated that we should publish several of the responses to the above question, and we begin with giving that of Mrs. Anna Tauner of Louisiana. Others will appear in due time, as space will allow.—Ed.]

SUNDAY.—Cold ham or tongue. Stewed oysters. Boiled eggs. Cold light bread, brown bread, and warm light rolls. **MONDAY.**—Ham and eggs (fried). Small hominy or grits. Waffles. Corn-batter cakes. **TUESDAY.**—Beefsteak with gravy. Lye corn. Muffins. Toast. **WEDNESDAY.**—Broiled mutton chops. Biscuit; puffs (or fried biscuit). Omelet. Cold mush fried. Toasted cheese. **THURSDAY.**—Fried chicken and boiled rice. Fritters; buckwheat or rye batter-cakes. **FRIDAY.**—Sausages. Large hominy. Fried sweet-potatoes. Sally Lunn. Corn griddle-cakes. **SATURDAY.**—Hash, dry or with gravy. Fried oysters. Cold potatoes, mashed and made into fritters. Gems; pancakes; corn-bread.

Coffee, butter, and molasses at every meal. Milk and chocolate when convenient.

In the summer-time I always have curd or cottage cheese, melons and whatever fruit is in season.

Mrs. Tauner proceeds to give recipes of the less known dishes mentioned above, as follows:

FRIED CHICKEN is the best breakfast dish I know of, and can be quickly prepared if the chicken is picked and cleaned the night before. Rice always accompanies chicken in Louisiana.

FRIED SWEET-POTATOES.—The evening before they are wanted peel and slice them, lay them in a stew-pan and sprinkle sugar between the layers of potatoes; pour on water enough to cover them, and set the stew-pan on the stove. In the morning, by the time you are ready to fry them, they will be cooked just enough; fry in hot lard to a light brown on both sides.

LYE-CORN is made by boiling corn with sifted wood-ashes until the outer skin or "husk," as we call it "down South," easily slips from the grain. Then it is cleansed of all impurities. Put into a kettle and boil all day, changing the water frequently. The fresh water added should always be warm. When quite done pound well with a wooden pestle. I generally have enough made to last a week in cold weather. When wanted for use, take

about a quart of the corn, put it in a stew-pan with half a pint of sweet milk; salt and pepper to your taste. Set it to simmer until wanted. Just before serving add two well-beaten eggs stirred in briskly. [This is called Hulled Corn in New England.—Ed.]

CORN-BREAD.—Pour over a quart of sifted meal a very little hot water; if scalded too much the bread will certainly be clammy. Add to it four well-beaten eggs and half a tea-spoonful of soda dissolved in warm water. The whole thinned to a soft batter with clabber or buttermilk. Have your pan very hot; put into it a piece of lard the size of a walnut; as soon as it melts pour in your batter and bake.

BATTER CAKES.—Take half a pint of sifted meal and make a mush of it; thin the mush with half a pint of sweet milk; add two eggs and flour enough to make the cakes turn.

In speaking of the difficulty of finding a servant who will have breakfast by daylight on a wintery morning, and the necessity of doing it herself, Mrs. T. evidently intends her remarks for the editor only, but the following is so sensible that we trust she will excuse us for publishing it:

"I do not like to cook, nor am I a capital house-keeper. But there is one thing I can do well, that is, submit with cheerful grace to whatever is inevitable. It is not so much over-work that wears a woman's life away as constant fretting about distasteful work. Life is too short not to accept with a thankful heart the blessings, be they many or few, that fall to our lot."

Renovating Old Feathers.—Mrs. C. L., of South Carolina, sends her method of treating old feathers, as follows: Expose them to the sun in an old mosquito net (or coarse corn sacks will answer) until perfectly dry, shaking them up from time to time. To get out the dust, they must be tied up to some convenient place in the yard and well beaten up with the hands or a stick (the person standing to windward, of course). If a lace net is used, feathers may be as thoroughly dried and sifted in this as can be desired.

Cake-Making.

Every lady thinks her way of making cake is the best. We give here what Mrs. H. B. P., a New Jersey lady, thinks is the best:

In reading your May number of the *Agriculturist* I see some very good advice from Faith Rochester about making cake, but I think she might have improved the making of the cake had she told us to add the soda the last thing instead of the whites of the eggs. This I think the secret of having light cake. Beat the sugar and eggs as she says; in putting in the milk save out a great spoonful to dissolve the soda in; then get the cake all ready for the oven; have your baking-tins all ready; then put the soda in, stirring it as quickly as possible, and put it into the oven just as soon as you can do so; the heat will be acting at the same time with the soda and cream-of-tartar. I think one that has never tried this way of doing will be surprised to see the difference it will make in lightness of the cake.

TEA CAKE.—One cup of sugar; one great spoonful of butter; half cup of milk; two cups of sifted flour; a very little nutmeg; one tea-spoonful of cream-of-tartar; half a tea-spoonful of soda.

MOUNTAIN CAKE.—One cup butter; three cups of white sugar; four of flour; five eggs, whites beaten separately; one tea-spoonful of cream-of-tartar; one of soda dissolved in the milk.

FRUIT CAKE WITHOUT EGGS.—Two-thirds of a cup of butter; two cups of sugar; two cups of raisins; two cups of currants; two cups of sweet milk; two tea-spoonfuls of cream-of-tartar; one of soda in the milk; six cups of flour; one nutmeg; one table-spoonful cinnamon, allspice, cloves, each; half pound of citron improves it. Bake slowly.

BOYS & GIRLS' COLUMNS.

A Beautiful and Curious Stone.

Do you recollect that in speaking of the different forms of limestone in November last, I said, "In some limestone regions crystals are found, some of which are as transparent as glass?" This most beautiful kind of limestone is found in the greatest perfection in Iceland, and it is called Iceland spar wherever it may be found. Our neighbors, Rohbeck and Goebler, dealers in chemical articles, No. 4 Murray street, bought the finest specimen

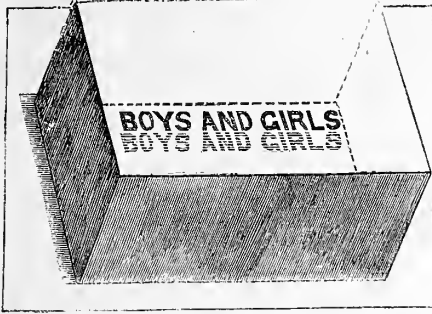

Fig. 1.—DOUBLE REFRACTION.

that was sent from Iceland to the great Vienna exhibition. It was something like a foot long and about four inches thick, and "as clear as a crystal." The shape of this crystal is a rhomb (which you must look in your dictionary for), and when broken—it breaks very easily—all the pieces, however small, are rhombs. Is not it strange that this crystal, so perfectly transparent, should be just the same thing as limestone or marble? "Look through it?" Yes, you can not only see through it, but you can see double. If you place it over a line on a paper you will see two lines, and if over a word two words will appear as in figure 1. This is called double refraction. This makes it necessary to explain refraction, which means bending. When light passes through the air it goes in straight lines; if it passes from the air through glass or through water it is refracted, or bent



Fig. 2.—REFRACTION IN WATER.

out of the straight line. You have no doubt noticed that a straight stick placed partly in the water appears as if bent at the surface, and you have seen how curiously out of shape things look when seen across a hot stove, the light going through the air, made thin by the heat of the stove, gets bent or refracted. In fig. 2 is shown a knife upon which is placed a coin and immersed in a glass of water; the knife appears bent as shown by the dotted lines. This is simple refraction, of which you may see cases frequently. Now the Iceland spar and some other minerals possess the remarkable power of doubly refracting. The light in passing through it is split into two parts, which are separated by the crystal, and in looking through it we see two things instead of one. This property which this crystal has of splitting up light in this way has enabled men to learn much more about light than they would otherwise have known, and I hope that when you get old enough you will read about the wonderful discoveries this has led to.

THE DOCTOR.

How Business is Done Under the Sea.

Every boy and girl knows that there are several telegraphic cables between this country and Europe, and that we are able to read in our evening papers what was done in London and Paris during the day. There are also many business messages sent as well as those relating to private and family matters. Just think of that bundle of slender wires surrounded by gutta-percha called the cable. How it rests upon the sea bottom, far, far down below the waves and storms; how

it lies in low valleys and hangs over mountain peaks, from the bottom of the ocean is as rugged as the land. Just think how wonderful it is that news of wars, news of banks and markets and news of deaths and births, of safe arrivals and of losses at sea, can be sent along this wire for thousands of miles and travel faster than the time kept by the sun. It costs much to lay these wires, and much to keep them at work; hence those who use them have to pay a large sum for sending messages. At one time it cost £1, or \$5 a word, but it is very much cheaper now, but not so cheap that it is not necessary for those who use it much to arrange plans to make the words as few as possible.

Merchants doing business devise what they call a telegraphic code. Let us suppose that you are doing business in London and that we are upon this side and that we are engaged in selling cotton. We agree by letter that certain words to which each has the key shall mean certain things. For instance, "Box six" we have agreed shall mean "cotton is higher, do not sell," and so on. We can give you an idea of a code actually in use. A large seed establishment furnishes its dealers with its code. Each principal variety of seed is represented by a short word and the pounds or bushels by letters—thus A. B. C. D. stand for 5, 10, 15, 20 lbs, or 1, 2, 3, 4 bushels and so on.

McLean's Advancer Pea is represented by Smith, so a dealer instead of telegraphing "Please send me one hundred and twenty-five bushels of McLean's Advancer Pea," simply telegraphs "T. L. E. Smith." The clerk who receives this by looking at the printed code sees at once what is wanted. Counting each letter as a word we have only four to express the whole order which in the usual way would require fifteen words, and as such messages are charged so much a word a great saving is made. Other kinds of business have similar codes.

About "English Currants."

Wyna, aged 11, is a girl whom I like. I never saw her, but she "wants to know," and that is why I like her. She has seen English currants used in cake and other cookery, and noticing that they were not like the currants that grow in the garden, she wishes to know more about them. Being unable to get the information elsewhere, she comes to the old doctor with the questions, "Where do English currants come from? how do they grow? and how cured?" In the first place, English currants are so called because they are neither "English" nor "currants." This is not a very promising start, but let me explain. In "old times" most foreign things came to this country by the way of England, and the name English was given to things that came from other parts of Europe. For some of these things the name is kept to the present time—thus the grocers keep English walnuts and English currants, and the painters use English vermilion, and some farmers sell English hay. The "English" currants come from Greece; and as they were sent from Corinth, they were in former times called Corinths, and it was the easiest thing in the world to say Corinths, Corinths, Currants. So much for the name. Now, what are they? They are small, imperfect, seedless grapes, not just like the grape that we have, but the European grape, such as raisins are made out of, and such as you see sometimes imported fresh in sawdust. For some reason or other, the grape which is so fine in other parts of Europe has degenerated in parts of Greece; it has no seeds, and remains very small, and when dried in the sun makes the currants. It is said that sometimes bunches come on the vine, the grapes on which have seeds in them, and grow to be good-sized berries, and no longer of use as currants. It is also said that the vines which produce these poor little currant-like grapes, when taken to other countries, no longer bear the little berries, but go back to the original state. So you see "English currants" are really very poor grapes from Greece. Now I wish all the boys and girls to follow the example of Wyna, and when they get "puzzled" about such things, as she says she was, to ask their friend, THE DOCTOR.

Aunt Sue's Puzzle-Box.

NUMERICAL ENIGMAS.

1. I am composed of sixteen letters. My 3, 15, 1 is often sought by laborers. My 1, 4, 5, 6 is a half statue. My 10, 12, 14 is a Sabbath-day cooler. My 5, 16, 7, 8, 9, 12, 13, 9 is an ensign. My 3, 2, 11, 13 is to scoff. My whole is a good maxim.

W. E. H.

2. I am composed of twelve letters. My 8, 9, 10, 11, 12 may be seen on a house. My 1, 4, 6, 3 is a relative. My 5, 2, 7, 11 is an animal. My whole come in the fall of the year.

AMANDA VELSOR.

CROSS-WORDS.

1. My first is in lamb but not in sheep. My next is in wake but not in sleep. My third is in study but not in play. My fourth is in March but not in May. My fifth is in taste but not in smell. My whole is a name not hard to spell.
HATTIE KETCHUM.
2. My first is in sirloin but not in chop. My next is in dandy but not in fop. My third is in Tom but not in Bill. My fourth is in luck but not in skill. My fifth is in verb but not in noun. My sixth is in village but not in town. And now if the letters right you will take, The name of a gentleman they will make.
MINNIE.

ALPHABETICAL ARITHMETIC.

RATS) CANNOT EAT (E R C F C F
CNRA

E K A O
R A T S

N F N T
O K E F

R C C C E
R E N N C

N N S A
O K E F

R E F R T
R E N N C

K F

M. L.

SQUARE-WORD.

1. The farmer's friend.
 2. A jovial fellow.
 3. A proclamation.
 4. Much used in schools.
 5. Worn by a lady.
- S. F. STARKEY.

HIDDEN NAMES OF ANCIENT GRECIAN DEITIES.

1. The oven used to get red-hot.
 2. James cast or molded some feet for the stove.
 3. It was a turning point in his life.
 4. Lucy, be less rough in your manners.
 5. The odor is refreshing.
 6. That ship going out to the ocean used to be owned by my uncle.
- WILLIAM P. ALBRIGHT.

ORNITHOLOGICAL AMPUTATIONS.

1. Behead a bird, transpose, and leave a lofty place.
 2. Behead a bird and leave a friend.
 3. Behead a bird, transpose, and leave "to languish."
 4. Curtail a bird, transpose, and leave a political party.
- O. A. GAGE.

ANSWERS TO PUZZLES IN THE DECEMBER NUMBER.

NUMERICAL ENIGMA.—Washington.

DIAMOND PUZZLE.— W
A I R
M A N L Y
W I N D I N G
P R O T O T Y P E
T R U S T W O R T H Y
C A T T L E G R A Z I N G
W I N D O W G A R D E N I N G
U N C O N T R O L L I N G
F R I E N D S H I P S
G A R D E N I N G
C O U N T R Y
A L I C E
A N D
G

RIDDLE.—Noise.

CHEMICAL PUZZLE.—Nitrogen.

- ANAGRAMS.—1. Personate. 2. Everlasting. 3. Accomplished. 4. Balconics. 5. Magnificent. 6. Endearments. 7. Unrepresentable. 8. Affiliate. 9. Influential. 10. Contribute.

ALPHABETICAL ARITHMETIC.—
316)920754(2913 (Key: Wild monkey.)

CONCEALED SEAS, GULES, BAYS, ETC.—1. Siam. 2. Black. 3. North, Dover. 4. White. 5. Lenga.

AUNT SUE'S NOTICES TO CORRESPONDENTS.

Thanks for letters, puzzles, etc., to W. E. H., Jr., L. N., Fred S., J. T. D., Ellen, and Emma W. A. AUNT SUE'S address is Post-Office Box 111, Brooklyn, N. Y. Some time ago some one asked me how to press flowers for making floral ornaments. I wrote an answer to

the question, but owing to the rush of rivers that month my notice was crowded out. Perhaps "better late than never" will apply in this case. Spread a thin layer of raw cotton upon a sheet of note-paper. Upon this place your flower, which must then be flattened with the fingers, arranging it gracefully into shape. Draw carefully between the petals, where they touch each other, "the least little bit" of raw cotton. Place another thin layer of cotton over the whole, then put the *flower sandwich* between the leaves of a book, and leave it, for not less than a week, under a heavy weight. At the end of that time you may take off the cotton, and with a needle carefully withdraw the fibers of cotton from between the leaves. Should you wish to preserve the flowers in their original shape lay them (where they will not touch each other) in a box one-eighth full of fine, white, clean sand which has been thoroughly dried in an oven. Then gently dust sand over them until they are entirely covered. Place the box in the hot sun (or in a moderately warm oven for two or three nights). When you wish to remove them from the box lift it so as to let the sand run off very gradually until the flower is released. Some flowers preserve their color and shape wonderfully well under this treatment, and may be made up into bouquets which will last all the winter. The flowers must be quite dry when taken out of the box or they will not keep. Some may take a week or two before it will be safe to disturb them.

with the fine brick and brown-stone houses of the wealthy. To every shanty belong numerous children, several dogs, and one or more goats, not to mention the grown people, and it may be conceived that a neighborhood of them

account of his troubles with that goat, which he said, "had barked everything upon the place except the crow-bar." The goat takes especial delight in barking trees, as many a one who has planted trees in front of his house and has delayed in getting tree-boxes knows to his sorrow; perhaps the next best thing to a goat's mind to spoiling trees is despoiling shrubs. The rascals wait until the little city front-yard is nicely put in order with flowering shrubs and vines, and then when in an unguarded moment the gate is left open the demolition is accomplished in short order. If no green thing can be had the goats content themselves with paper and cloth. We have seen posters and placards stripped from a fence as high up as they could reach by standing on their hind legs, and if a washing is left unguarded upon the line the sheets and tablecloths will be found in a sad plight. The green-grocers, who are very apt to set their vegetables and fruit upon the sidewalk, have to keep a special lookout for their property or a sudden attack may bring them to grief, and many a workman upon the streets who has put his dinner kettle in what he thought was a safe place, has been unintentionally providing a meal for these street Arabs. We sometimes see a pair of goats in a fine harness drawing an elegant little coach which contains some rich man's son. These goats are for the most part trained by the poor boys of the shanties, and begin their education in a harness made of odds and ends of twine, ropes and leather, and are attached to a rude wagon made of a box. After the goats have done all the mischief they can think of for one day they must rest, and for this purpose they select the finest and sunniest door step, where they take their

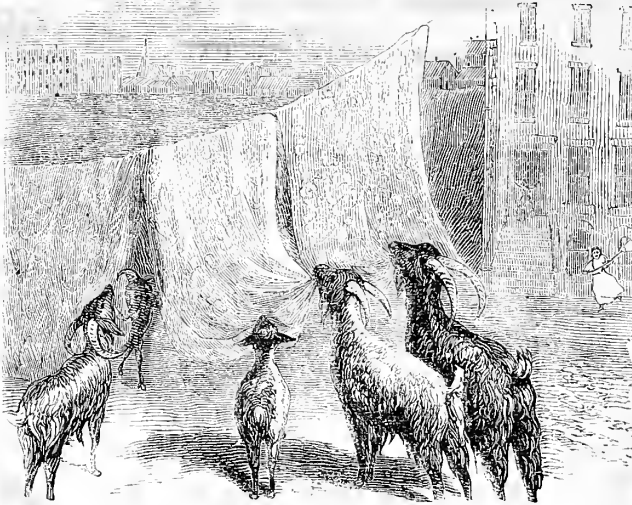

TROUBLE FOR THE LAUNDRESS.

is not especially pleasant. As the goats often run loose in spite of law they are a source of no little annoyance to the whole vicinity. The monkey is regarded as the most mischievous of animals and perhaps he is, but the goat is not much his inferior, and goats are common while monkeys are not. Goats are kept for their milk, which

and begin their education in a harness made of odds and ends of twine, ropes and leather, and are attached to a rude wagon made of a box. After the goats have done all the mischief they can think of for one day they must rest, and for this purpose they select the finest and sunniest door step, where they take their

A Piece about Goats.

Goats, in this country at least, are mostly to be found in towns and cities, and as they for most part are the



LITERARY TASTES.



A RAID UPON THE GREEN-GROCER.



PAT'S DINNER.

property of the poorer Irish and other Europeans who live in the cheapest dwellings they abound in the outskirts and are rarely seen in the older parts of the towns. In New York, for instance, there are many tracts of land which, belonging to unsettled estates or for other rea-

is by some preferred to cow's milk; they are often trained to submit to the harness and to draw small carriages; and kids are eaten. The ostrich is said to eat everything that comes in its way and to have a special liking for tenpenny nails and broken glass. We never

ease, and are ready to dispute possession with the occupants of the house. "Why is not this mischief stopped?" you will ask. Sometimes the police do take the goats to the pound—and sometimes they do not, especially if the goat happens to be a large buck and has an opinion

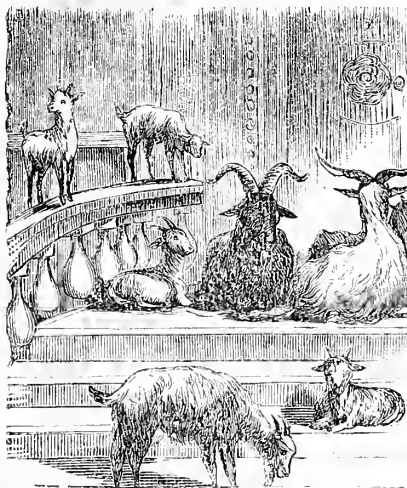

A REST AFTER MISCHIEF.

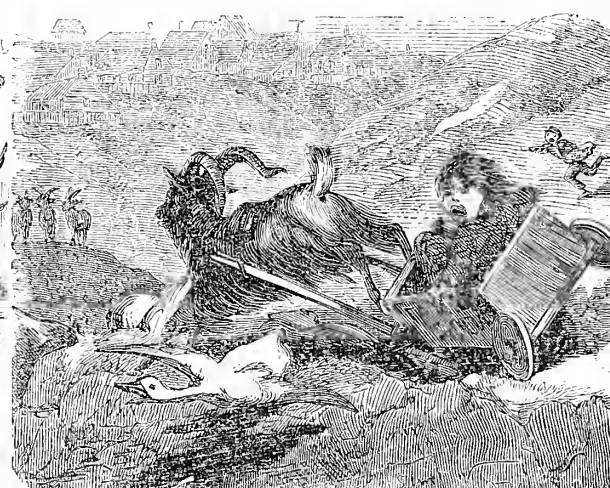

A CHARIOTEER IN TROUBLE.



TAKING HIM IN.

sons, are not occupied by their owners but are usually thickly covered with shanties. It is not a rare thing to find a "huddle" of these shanties, built of old lumber, packing-boxes, and every conceivable material, occupying land upon a street which in another part is built up

saw a goat partaking of these delicacies, but should not be at all surprised to see one at it. A number of years ago Horace Greeley had a goat upon his farm for the purpose of furnishing milk for a weak child. He wrote to the *Agriculturist* a very funny

of his own on the subject. Besides these collections of shanties turn out a great many voters, and it sometimes is the case magistrates do not care to gain their ill-will by enforcing a law that is unpopular with such a large number of their constituents.

Life Insurance.

INSURANCE differs from other business pursuits only in that it protects each individual of the community from the overwhelming consequences of a possible calamity to which he, in common with others, is exposed, by collecting, conserving, and disbursing the contributions of the many for that purpose; and in this sense it is an eleemosynary institution.

Tried by this standard, it will be found that the business of insurance does differ materially from other pursuits; that it is almost sui generis; that it does "perform a great charity," and performs it all the better because it performs it as a business, on business principles, and with the sagacity that is always exhibited in matters of profit and loss; in fine, that it is hardly less indispensable to civilization and material progress than is government itself.

If we turn to life insurance, the force of these considerations will be even more apparent. Life insurance not only "performs a great charity," but is a great charity—perhaps the greatest that has ever been conceived by man. Over hundreds of thousands of homes, which were else left at the mercy of the great destroyer, it extends its beneficent protection, and, in the hour of deepest bitterness, pours out a sympathy that is metallic; and if it can not replace the lost husband and father, preserves to the bereaved the home which his hands had earned and his love bestowed. Who shall attempt to measure the influence for good of this greatest of all the charities? What misery and want, what desperation and crime, so largely the results of poverty, are thereby prevented.

But life insurance, for this very reason, is a business which depends more than others upon the confidence of the community; and the companies who best deserve that confidence will be the successful companies of the future. Among these the United States Life Insurance Co. of this city is conspicuous; and in addition to the many other proofs of honest dealing and thorough solvency which it has so often given, the appearance of its annual statement for 1873, on the morning of January 1st, 1874, is a further earnest of its good faith. This is a punctuality never before attempted, much less attained. The statement has been verified by us so far as to show that, of the assets therein reported, every dollar, except the relatively insignificant sum of \$25,000, was in possession of the company at the time of making the statement. This is unprecedented in the history of life insurance, and shows that the managers of the United States Life deserve to succeed, if fidelity to their trust and considerate recognition of the claims of the public deserve success.

Peruvian Guano.

Messrs. HOBSON, HURTADO & Co., Financial Agents of the Peruvian Government, assure us of the thorough reliability of the special agency just established for the sale, in large or small quantities, of above article at importers' prices.

To Tea Drinkers!

On this page appears the circular of the Consumers' Importing Tea Company. We believe this Company able and willing to perform all that their circular proposes.



Breech-Loading Shot-Guns of all the celebrated makers. Sturtevant's Patent Brass Shot Shell.

Shooting Tackle of every description. Send for Descriptive Catalogue. SCHUYLER, HARTLEY & GRAHAM, 19 Maiden Lane, New York.

What is the use of buying a good shoe if it will be through at the toe in two weeks?

SILVER TIPS Prevent this.

MAMMOTH BRONZE TURKEYS and POULTRY. L. L. REED, Auburn, Ohio. Circulars free.

(CIRCULAR.)

Consumers Importing Tea Co., No. 8 Church Street, P. O. Box 5,509. New York City.

This is a combination of capitalists to supply the consumers of Teas throughout the United States on the mutual principle.

We have experienced agents in all the best districts of China and Japan to select Teas especially for our trade.

We expect every consumer of Teas to render us all the assistance they can in carrying out our enterprise, as we make a specialty of SUPPLYING CONSUMERS ONLY (and allow no middlemen to make any profit on our importations), which will enable us to supply them with Teas at prices lower than have ever been known, and of those fine qualities that seldom reach the interior, being sold only in the large cities and among the very wealthy.

Hoping the consumer will take an interest in our enterprise, and send at once for a circular with full explanations of how to proceed to obtain our goods, we remain,

Most respectfully yours,

Consumers Importing Tea Co., No. 8 Church Street, P. O. Box 5,509. New York City.

Entered, according to Act of Congress, in January, 1874, by the Consumers Importing Tea Co., in the Office of the Librarian of Congress, Washington, D. C.

SEEDS OUR BEAUTIFULLY ILLUSTRATED CATALOGUES for 1874. of SEEDS AND PLANTS. Numbering 175 PAGES, and containing 2 fine large colored plates, are now ready. To our patrons they will be mailed as usual free; to all others, on receipt of 25c., which we return in Seeds or Plants, with first order. All purchasers of our Books, either Gardening for Profit, or Practical Floriculture Price \$1.50 each (prepaid by mail,) have their names entered on our lists, and will receive above Catalogues annually, free of charge. Peter Henderson & Co. Seedsmen, 35 Cortlandt Street, New York.

Druggists, Booksellers, and Others

RETAILING SEEDS

Are respectfully informed that our Trade List for 1874 is now ready, and will be mailed to all dealers on application. Vegetable and Flower Seeds neatly put up in boxes for retailing, by the sale of which the retailer realizes upwards of 100 per cent profit. Attractive Show Cases furnished with each box.

VEGETABLE SEEDS.

Box No. 1-90 varieties. Retail for \$60.00. Trade price, \$30. " 2-66 " " " 40.00. " " 20. " 3-45 " " " 20.00. " " 10.

FLOWER SEEDS.

Box No. 4-100 varieties. Retail for \$60.00. Trade price, \$30. " 5-75 " " " 41.50. " " 20. " 6-50 " " " 20.00. " " 10.

A list of the contents of each box will be found in Catalogue. No seeds sent out on commission. Orders must be accompanied by cash or satisfactory reference. Address

B. K. BLISS & SONS, 23 Park Place and 20 Murray Street, P. O. Box 5712. New York City.

CHOICE SEEDS.

Market Gardener's Stock FOR EARLY PLANTING.

Fottler's Brunswick Cabbage.....Per oz., 75c. Per pkt., 15c. True Jersey Wakefield do. " 75c. " 15c. Boston Market Dwarf Celery..... " 50c. " 10c. Hooped Lettuce..... " 50c. " 10c. White Spined Hotbed Cucumber. " 50c. " 10c. Our new Seed Catalogue for 1874 will be ready February 1st. Free to all applicants. Address SCHLEGEL, EVERETT & CO., 16 South Market St., Boston, Mass.

SEEDS.

TRADE LIST for dealers only mailed to all applicants. Address KERN, STEBER & CO, Seedsmen, St. Louis, Mo.

Trees and Plants. S. B. PARSONS & SONS, FLUSHING, N. Y.

GEO. A. PRINCE & CO. ORGANS & MELODEONS.

The Oldest, Largest, and Most Perfect Manufactory in the United States.

53,000

Now in use.

No other Musical Instrument ever obtained the same popularity.

Send for Price-Lists. Address

BUFFALO, N. Y.

"The Best Article in the Market." ASBESTOS ROOFING

H. W. JOHNS, 87 Maiden Lane, N. Y. Patentee and Sole Manufacturer. Established 1858.

GLASS CUTTERS



Our Glass Cutters are made with a handle like a Glazier's Diamond, but instead of the diamond point, they have a small hardened Steel revolving wheel, the sharp edge of which cuts nearly as well as a diamond. They are durable, and will give entire satisfaction. Most Hardware Dealers keep them, or will send to us for them if wanted. Where they are not for sale, we will send one by mail, prepaid, on receipt of thirty-five cents.

We will send one to any publisher who will insert this notice and forward us a copy prepaid. MILLERS FALLS COMPANY, No. 78 Beekman Street, New York.

THE ATLANTIC for 1874

Begins its thirty-third volume under the most prosperous auspices. The new publishers will spare no pains to keep it the LEADING AMERICAN MAGAZINE, containing the fresh writings of

LONGFELLOW, WHITTIER, HOLMES, LOWELL, HOWELL, BAYARD TAYLOR, ALDRICH, WALNER, WELLS, PARTON, OWEN, EGGLESTON, with able criticisms upon current literature, art, and science.

PRUDENCE PALFREY

is the title of the novel begun in the January number by that witty writer, THOMAS BAILLY ALDRICH.

Personal Reminiscences, by the Poet WHITTIER, will cover an eventful period in our history, and the volume promises to be an UNUSUALLY BRILLIANT ONE.

TERMS.—Single or specimen numbers, 35 cents. Yearly subscription, \$4.00. The Atlantic and Every Saturday (\$3.00) sent to one address for \$8.00. Address the publishers,

H. O. HOUGHTON & CO., Boston. HURD & HOUGHTON, New York.

Automatic PUMPS. Water driven to any height and distance by compressed air. Country houses supplied cheaply and certainly for bath-rooms, water closets, hot and cold water faucets, etc. Plenty of fresh water for stock on farms. Address HARTFORD PUMP CO., 41 Trumbull St., Hartford, Conn.

None Perfect. Cable Screw Wire THE BEST.

BRYANT'S BOOK-KEEPING — For Self-Instruction and Schools. The cheapest and best work ever published. 120 pages. Sent post-paid on receipt of 75 cents. Address J. C. BRYANT, Prin., Business College, Buffalo, N. Y.

MONEY MADE RAPIDLY with Stencil and Key Check Orders. Catalogues and full particulars free. S. M. Spencer, 117 Hanover St., Boston, Mass.

AGENTS LOOK!—\$12 a day made selling Scissors Sharpener and other wares. Sample 25 cts. Catalogue free. T. J. HASTINGS & CO., Worcester, Mass.

Rare & Beautiful Flowers
AND
CHOICE VEGETABLES.

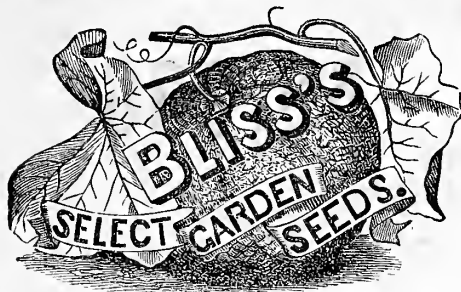

The Nineteenth Annual Edition of our celebrated Seed Catalogue and Amateur's Guide to the Flower and Kitchen Garden, containing upwards of 200 pages, including several hundred finely executed engravings of favorite flowers and vegetables, and a beautifully colored chromo, with a supplement for 1874, is now in press, and will be mailed to all applicants upon receipt of 25 cents. An edition elegantly bound in cloth \$1.00.

BLISS'S GARDENERS' ALMANAC and Abridged Catalogue contains upwards of 100 pages, and embraces a monthly calendar of operations and a price-list of all the leading Garden, Field, and Flower Seeds, with brief directions for their culture. A copy will be mailed to all applicants inclosing two three-cent stamps.

Bliss's Illustrated Potato Catalogue free to all applicants. Address

B. K. BLISS & SONS,
Nos. 23 Park Place and 20 Murray St.,
P. O. Box 5712. New York.

The Five Best Tomatoes.

ARLINGTON.—Early, solid, unusually smooth, fine flavored, large size, enormously productive, and excellent market variety. 25 cts. per packet; five packets for \$1.00; \$2.00 per ounce.

CANADA VICTOR.—The earliest in cultivation. Seed grown from the original stock. 15 cts. per packet; \$1.50 per ounce.

TROPHY.—Very large, smooth, solid, and of fine quality. Seed saved from selected fruit. 10 cts. per packet; 50 cts. per ounce.

HATHAWAY'S EXCELSIOR.—Very early, smooth, solid, and an excellent variety in every respect. 10 cts. per packet; 60 cts. per ounce.

GRAPE-SHOT.—Fruit orange-scarlet, averaging 1 to 1½ inch in diameter, which is produced in long clusters. Very ornamental, as well as useful for the table or for pickling. 15 cts. per packet; \$1.50 per ounce.

One packet each of the five varieties will be mailed to any address upon receipt of 65 cts. Address

B. K. BLISS & SONS,
P. O. Box 5712, New York.

\$1,500 IN PREMIUMS.

Important to Potato Growers.

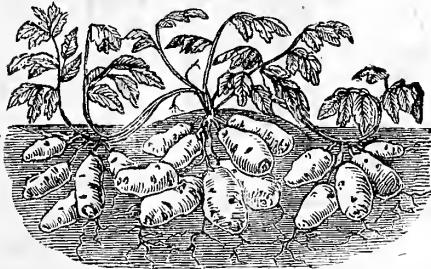

COMPTON'S SURPRISE—Showing Habit of Growth.

\$750.00 to be divided among the six successful competitors who shall produce the largest quantity of either of the following varieties of Potatoes: **EXTRA EARLY VERMONT,** **BROWNELL'S BEAUTY,** or **COMPTON'S SURPRISE,** from one-quarter of an acre of measured ground. \$250 for each variety.

\$750.00 to be divided among the six successful competitors who shall produce the largest quantity from **ONE POUND** of the seed of either of the above named varieties. \$250 for each variety. Subject to conditions named in our Potato Catalogue, a copy of which will be mailed to all applicants.

The Seed in all cases to be purchased from us. Address

B. K. BLISS & SONS,
23 Park Place and 20 Murray St.,
P. O. Box 5712, New York.

B 4 U ORDER SEEDS,

BRIGGS & BRO'S

January Quarterly!

The finest Floral Work ever issued in this country. Published Quarterly—the four numbers sent to any address for 25 cents—comprising an Illustrated and Descriptive Catalogue of the Seeds, Bulbs, and Plants sold by **Briggs & Brother, Seedsmen and Florists,** Rochester, New York, together with elaborate treatises upon the care and culture of the same. **Over 1,000 Premiums** taken in the United States in 1873 upon the products of **BRIGGS & BROTHER'S SEEDS.**

The January number alone will be worth more than a \$2 book. Parties purchasing \$1 worth or upward of Seeds are credited with a subscription for the following year.

We challenge comparison on prices and size of packets. Address **BRIGGS & BROTHER,** Rochester, N. Y.

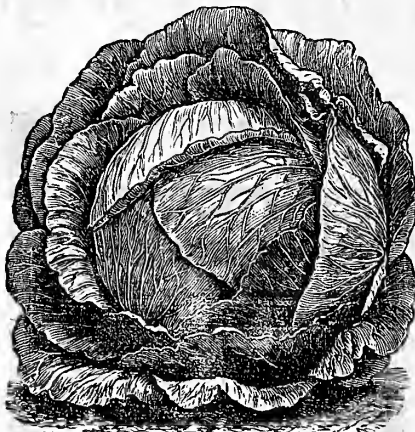

Fottler's Early Drumhead.

Farmers and Gardeners, you all need this Cabbage for two reasons: 1st, because it is the earliest of all the Drumhead varieties; 2d, because every plant on an acre will make a large and solid head. Seed of my own growing sent postpaid by me for 15 cts. per package, 75 cts. per ounce, \$8 per pound. My Seed Catalogue free to all applicants.

JAMES J. H. GREGORY, Marblehead, Mass.

Seed Time Cometh!

The twenty-first editions of our illustrated FLOWER and KITCHEN GARDEN DIRECTORIES for 1871, with a Supplement of Novelties and Selections, embracing a list of Seed grown by the best Boston Market Gardeners and also by the most famous European growers of flowers and vegetables, including many that can rarely be found elsewhere, will be forwarded about the first of February to all customers free of charge, and to other applicants inclosing a three-cent stamp.

D. T. CURTIS & CO., 161 Tremont St., Boston, Mass.

Successors to CURTIS & COBB.

Seed for Early Forcing.

Boston Market Tennis Ball Lettuce—½ oz. 75c.; 15c. ¼ pkt. White Spined Cucumber, Improved—“ 50c.; 15c. “ Long Frame Cucumbers, varieties—“ 25c. “ French Breakfast and Olive-shaped Radishes—½ oz. 10c. Boston Market Celery—½ oz. 50c.; ¼ pkt. 10c. Early Jersey Wakefield Cabbage—½ oz. 75c.; ¼ pkt. 10c.

CHOICE SEEDS.

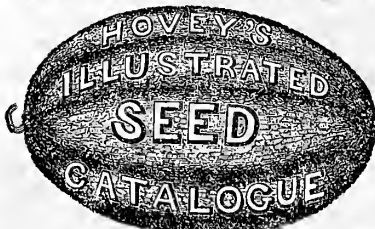

FOR 1874

Sent free to our customers, and to all others on receipt of two 2-cent stamps for the postage.

HOVEY & CO.,
53 North Market St., Boston, Mass.

GIVEN AWAY A package of CHOICE FLOWER SEEDS and sample of Park's Floral Gazette. Address, with stamp, Geo. W. Park, Faupetsburg, Pa.

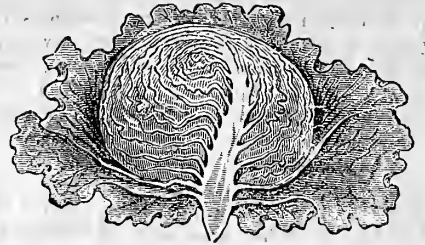

The HANSON LETTUCE.

The most tender, sweet, and delicious variety grown; free from any bitter or unpalatable taste; heads large and solid, often weighing 3 lbs. Single pkgs. 25 cts. 5 pkgs. \$1. A LIBERAL DISCOUNT TO DEALERS. Sent for Dreyer's Garden Calendar for 1874, 168 pages, illustrated, with the practical directions. Mailed FREE to all applicants. **HENRY A. DREYER,** 714 Chestnut St., Philadelphia, Pa.



Hawley's Seed Catalogue.

NEW CROP GENUINE WETHERSFIELD ONION SEED.

R. D. HAWLEY'S

Annual Illustrated Catalogue of Fresh and Genuine Wethersfield (Conn.) Garden and Farm Seeds for spring of 1874 will be ready early in January to send free to all applicants.

Choice Stock. Moderate rates. Prompt delivery.

Address **R. D. HAWLEY,** Seed and Agricultural Warehouse, Hartford, Conn.



My business is to supply what every farmer of experience is most anxious to get, perfectly reliable Vegetable and Flower Seed. With this object in view, beside importing many varieties from reliable growers in France, England, and Germany, I grow a hundred and fifty kinds of vegetable seed on my four seed farms, right under my own eye. Around all of these I throw the protection of the three warrants of my Catalogue. Of new vegetables I make a specialty, having been the first to introduce the Hubbard and Marblehead Squashes, the Marblehead Cabbage, and a score of others. My Catalogue, containing numerous fine engravings, taken from photographs, sent free to all.

JAMES J. H. GREGORY, Marblehead, Mass.

NOW READY,

CROSMAN BROS'S Illustrated CATALOGUE and GUIDE to the Flower and Vegetable Garden for 1874, beautifully illustrated, and containing a magnificent Colored Plate of seven new and popular flowers. Sent FREE upon receipt of stamp. Address **Crosman Bros., Rochester, N. Y.** (Established 1840.)

TO THE SEED TRADE.

TRADE LIST FOR DEALERS ONLY, mailed to applicants.

J. M. THORBURN & CO., 15 John Street, New York.

THE DUDLEY SEED FARM.—Sent by Postal-Card for my new Spring Catalogue of Seeds, Plants, Lilies, Gladioli, etc., etc. Special inducements offered. **G. A. LAW,** Roslindale, near Boston, Mass.

Reliable Seeds.

Our Illustrated Seed Catalogue for 1874 is ready for distribution, and will be sent to all who apply, inclosing a stamp for postage. This Catalogue contains a complete list of all the valuable

Vegetable and Field Seeds and Grains.

Also a select list of

Flower Seeds and Novelties.

We offer a valuable premium as an inducement to Clubs and purchasers of large amounts.

R. H. ALLEN & CO.,

189 & 191 Water Street, New York.

TO FARMERS AND MARKETMEN.

You want none but the very best of seed, grown from carefully selected seed stock. With the money you have to invest in manure, help, and glass, you know you can not afford to use any other; you feel very anxious about it; TRY MINE. Catalogues free to all.

JAMES J. H. GREGORY, Marblehead, Mass.

SEEDS. **REEVES & SIMONSON,** **PLANTS.**
Seedsman and Florists,
 58 Cortlandt Street, New York.
 Our annual Illustrated and Descriptive Catalogue of Vegetable, Flower, and Field Seeds, also of Hot-house, Bedding, and Vegetable Plants is now ready for 1874. Sent on receipt of postage-stamp. Trade lists for merchants only sent on application.

THE IVY HILL NURSERY CATALOGUE

OF SMALL FRUITS, SEEDS, and SEED POTATOES will be mailed free to all applicants. Address

REISIC & HEXAMER,

Newcastle, Westchester Co., N. Y.

WHAT--WHERE ---WHEN---HOW

To Plant Farm, Garden, and Flower Seeds; what they will cost, and all other desirable information in our

HAND-BOOK for 1874,

Containing a Beautifully Colored Chromo.

Sent to all applicants, post-paid, on receipt of 10 cents, by

JAMES FLEMING, Seedsman,

67 Nassau St., New York.

SEEDS. If you want pure, reliable, and fresh Seeds, order them of **KERN, STEBER & CO.,** Seed Growers and Dealers, 211 Market St., St. Louis, Mo. Catalogues mailed to applicants.

PLANTS and SEEDS FOR EVERYBODY.

The choicest and best PLANTS and SEEDS, at low rates, safely sent by mail or express.

Extraordinary Incitements to Purchasers.

For our Illustrated Catalogue for 1874, inclose letter-stamp to the **BELLEVEU NURSERY CO. of PATERSON, N. J.**

HENRY E. CHITRY, Supt.

PEAR SEED Fresh, just arrived from France. 1 lb., by mail post-paid, \$2.50. 10 lbs., " " \$22.50. Larger quantities, special rates. Address **KERN, STEBER & CO.,** 211 Market St., St. Louis, Mo.

The Hutchinson Burner. (Price, 33 Cents, by Mail) No chimney needed. Fits the common lamps, and burns kerosene with a clear, steady flame two inches high, or any less light desired. For safety, convenience, and economy, unequalled. Sent by mail for 33 cents; two for 60c., with wicks. Write to **HUTCHINSON & CO.,** Cayuga, N. Y.



SEXUAL PHYSIOLOGY. By R. T. TRALL, M.D. Containing Sexual Generation; the Physiology of Menstruation; Impregnation; Pregnancy; Parturition; Lactation; the Law of Sex; Regulating the Number of Offspring; The Law of Sexual Intercourse; Hereditary Transmission; Philosophy of Marriage. Prof. Wilder, of Cornell University, says it is the best work yet written on the subject. 200 pp. sold. Price \$1.00 by mail. For \$1.50 we send this book, The Herald of Health for one year, and a volume of the Complete Works of Shakespeare, containing 1,000 pages and 36 illustrations. Agents wanted. **WOOD & HOLBROOK,** 15 Light St., New York.

VICTOR HORSE HOE.

BEST AND CHEAPEST STEEL HOE in use. THOROUGHLY Pulverizes and works close to plants, RAKE Attach't works the weeds out, has Hilling Plows First Premium SILVER MEDAL New England Fair, 1872.

EAGLE SEED SOWER, Plants in Hills or Drill 4 Sizes Prices \$8 to \$16.

CLIPPER WHEEL HOE, \$4 & \$5.50. Agents Wanted

Address **E. D. & O. B. REYNOLDS,** (Circulars Free.) NORTH BRIDGEWATER, MASS.

Or **CARR & HOBSON, Sole Agents,** 56 Beekman St., New York.

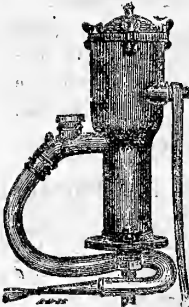

THE PEOPLE'S Force & Suction PUMPS.

For the house and out of doors, and for wells from 10 to 120 ft. deep. Awarded Medal of American Institute, Nov. 15, 1873, for "best force pumps" of all exhibited.

For list of Agents see advertisement in *Am. Agriculturist* for November, 1873, page 431, and send for circular and price-list.

W. S. ELUNT, 77 Beekman St., New York.

The Pulsometer or Magic Pump.

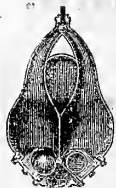

The simplest, most durable, and effective steam pump now in use. Adapted to all situations, and performs all the functions of a steam pump without its consequent wear and care. No machinery about it. Nothing to wear out. Will pump gritty or muddy water without wear or injury to its parts. It can not get out of order.

C. HENRY HALL & CO., 20 Cortlandt Street, New York City.

LOVEJOY'S NEW STYLE GLASS-CUTTER and PUTTY-KNIFE



is a better tool for cutting glass than anything ever offered for the purpose. Any child can use it. Every housekeeper, farmer, and mechanic should have one. Sent in neat box, prepaid, to any address upon receipt of 50 cents and letter-stamp by **ALVAN L. LOVEJOY,** 229 Washington St., Boston.

Wm. Gillett
STEEL PENS!
 Sold by all Dealers.
 No. 91 JOHN ST., NEW YORK.
HENRY HOE, Sole Agent. JOSEPH GILLOTT & SONS.

BUILDING FELT. This water-proof material, resembling fine leather, is for outside work (no tar substances used) and inside, instead of plaster. Felt carpetings, etc. Send two 3-cent stamps for circular and samples. **C. J. FAY, Camden, N. J.**



Self-Propel-For Cripples For In and Out Door Use. Can be EASILY one having the State your ease, for illustrated circulars and prices. Please mention this paper. **S. A. SMITH,** 90 William St., N. Y. City.



Improved Foot Lathes. Small Engine Lathes, Small Gear Cutters, Hand Planers for Metal, Ball Turning Machines, Slide Rests, Foot Scroll Saws. The very best. Selling everywhere. Catalogues free. **N. H. BALDWIN, Laconia, N. H.** Just the articles for Artisans or Amateurs.



\$75 PER WEEK

made by our agents throughout the country selling our celebrated La Perle Rubber Goods. Indispensable articles for Ladies and Children's wear. **LA PERLE RUBBER CO.,** 90 Chambers Street, New York.

A M A C R I. PAT. DEPT.



IMPORTANT TO INVENTORS. American Agriculturist PATENT DEPARTMENT

In compliance with the request of numerous inventors, we have organized a

PATENT DEPARTMENT in connection with this office for the transaction of all business connected with

Securing Patents in the United States and foreign countries.

The character for **Reliability**

which has been maintained by the AMERICAN AGRICULTURIST for more than thirty years will be carefully guarded in this as in other departments.

All Inventors

desirous of procuring patents at moderate cost are invited to forward (express prepaid) a model of their invention, with a brief description of its working. The model should not exceed one cubic foot in dimension. Upon receipt of model an opinion as to patentability will be given free of charge.

Preliminary Examination

at the Patent Office, to determine patentability, will be promptly made for a fee of \$5.

Litigation of Patents.

The services of the best counsel have been secured to prosecute or protect before the U. S. Courts and the Patent Office the claims of those intrusting their business to this agency.

Specifications, drawings, engravings, models, and all other appliances furnished at moderate prices.

In all dealings with this Department inventors may depend upon promptness, fidelity to their interests, and the best services which can be rendered by thorough experts. For full particulars, address

AMERICAN AGRICULTURIST PATENT DEPARTMENT, ORANGE JUDD COMPANY, 245 Broadway, New York.

ADVERTISING RATES.

American Agriculturist.

ENGLISH EDITION.

Inside Pages, \$1.50 per line (agate), each insertion. Open Pages (open without cutting), \$2 per line. Last Page, and 2d and 3d Cover Pages—\$2.50 per line. Page next to Reading and Last Cover Page—\$3.00 per line. No advertisement inserted for less than \$5.00.

GERMAN EDITION.

Inside Pages, 25 cents per line, each insertion. Business Notices and Last Page, 40 cents per line. No advertisement inserted for less than \$1.00.

Hearth and Home.

Inside Pages, per line (agate), each insertion..... 50 cents. Business Notices, 7th Page, and Last Page..... 75 cents. Reading Notices per line..... \$1.00 No Advertisement inserted for less than \$2.00.

No Advertisement of Medicines or Humbugs received. Address all orders to the

ORANGE JUDD COMPANY, 245 BROADWAY NEW YORK.

AMERICAN AGRICULTURIST.

ORANGE JUDD COMPANY, Publishers, 245 Broadway, N. Y. ANNUAL SUBSCRIPTION TERMS (always in advance): \$1.50 each for less than four copies: Four to nine copies, \$1.25 each: Ten to nineteen copies, \$1.20 each: Twenty copies and upward, \$1 each. Papers are addressed to each name. Either English or German Edition, at these prices. HEARTH AND HOME: \$3 a year for less than four. Four to nine copies, \$2.75 each; 10 or more copies, \$2.50 each. Hearth and Home (weekly) with American Agriculturist sent to one address for \$4 a year.

raising a club much larger than you had at first calculated upon; and even should you secure fewer subscribers than at first hoped for, the Premiums are so many and so various that you could not fail to be suited with some good thing on the list.

Persons of all classes have engaged successfully in the work, and very many have materially increased their income, and that too without encroaching upon their ordinary working hours and with but little trouble to themselves. The articles offered as Premiums are worth the regular price which is set against them. They are new and good. They have almost universally pleased and satisfied the recipient. You can obtain one or more of them.

TRY IT.

The American Agriculturist is everywhere known and approved. HEARTH AND HOME issued every week, with the Best Original Stories, contributions on Live Topics, a capital Household Department, and a most interesting Department for Children and Youth, should be in every home in America. The papers are entirely different. Taken together, they supply more good reading than can be found in fifty books costing one Dollar each.

Premium Clubs can be made up of subscribers to either paper, or partly of one and partly of the other, as noted over the Table. We call especial attention to the last column of figures, showing the small number of names required where both papers are taken, at the reduced price of \$4 a year.

You, Reader, can get a Premium. TRY IT.

Explanatory Notes.

N. B.

Read and carefully

Note the following items: (a) All subscribers sent by one person count, though from one or a dozen different Post-offices. But... (b) Tell us with each name or list of names sent, that it is for a premium... (c) Send the names as fast as obtained, that the subscribers may begin to receive the paper at once. You can have any time, from now until July 1st, to fill up your list... (d) Send the exact money with each list of names, so that there may be no confusion of money accounts... (e) Old and new subscribers all count in premium clubs, but a portion, at least, should be new names; it is partly to get these that we offer premiums to canvassers... (f) Specimen Numbers, etc., will be supplied free as needed by canvassers, but they should be used carefully and economically, and where they will tell... (g) Remit money in Checks on New York Banks or Bankers, payable to order of Orange Judd Company, or send Post-office Money Orders. If neither of these is obtainable, Register Money Letters, affixing stamps both for the postage and registry; put in the money and seal the letter in the presence of the Postmaster, and take his receipt for it. Money sent in any of the above ways is at our risk; otherwise it is not.

In the following table is given the price of each article, and the number of subscribers required to get it free, at the regular rates, \$1.50 a year for American Agriculturist, and \$3.00 a year for Hearth and Home; also at the club rates of \$1 and \$2.50; also at the rates of \$4 a year for both papers together. Description of Premiums sent free to applicants.

N. B.—In all Premium Clubs for either paper, TWO copies of American Agriculturist (English or German) at \$1.50 each, and ONE copy of Hearth and Home at \$3.00, will count exactly the same. So also two copies of American Agriculturist at \$1 each, and one copy of Hearth and Home at \$2.50, will count exactly the same. In this way Premium Clubs can be made up from the 2d and 4th columns, or from the 3rd and 5th, or wholly from the 6th column.

Table of Premiums and Terms For American Agriculturist, and for Hearth and Home, for the Year 1874.

Open to all—No Competition.

Table with 6 columns: No., Names of Premium Articles, Price of Premiums, American Agriculturist (only), Hearth and Home (only), Both Papers (together). Rows include items like Moore's Floral Set, Gold Pen, Gold Pen and Silver Case, Gold Pen, Handle gold-tipped, Ladies' Gold Pen and Rubber Case, Paragon Pen, Revolving Pencil, Paragon Pen, Revolving Pencil, Payson's Indelible Ink, Cake Basket, Revolving Butter Cooler, Card Receiver, One Dozen Teaspoons, One Dozen Tablespoons, One Dozen Table Forks, Child's Cup, Child's Knife, Fork & Spoon, Child's Carriage, Child's Self-operating Sewing, Doll's Cottage Chamber Set, Crandall's Building Blocks, Crandall's Masquerade Blocks, Knives and Forks, Knives and Forks, Knives and Forks, Carver and Fork, French Cook's Knife, Fork, and Steel, Pocket Knife, Pocket Knife, Ladies' Pocket Knife, Mitten in Parvo Knife, Garden Seeds, Extra Early Vermont Potato, Sewing Machine, Grocer & Baker, Sewing Machine, Florence, Sewing Machine, Willcox & Gibbs, Sewing Machine, Secor, Beekwith \$12 Sewing Machine, Beekwith Portable Family Sewing Machine, Washing Machine, Clothes Wringer, Melodeon, 4-octave, Melodeon, 5-octave, Piano, Siantia Tacet, Silver Watch, American Watch Co., Ladies' Fine Gold Watch, Breech-loading Pocket Rifle, Double-bbl. Gun, Remington's Breech-loading Rifle, Remington's Single-barrel Shot-gun, Charles Pratt's Astral Oil, Family Churner & Waster, Family Scissors, Worcester's Great Illustrated Dictionary, Any back Volume Agriculturist, Any Two Back Volumes do, Any Three do, Any Four do, Any Five do, Any Six do, Any Seven do, Any Eight do, Any Nine do, Seventeen Vols. XVI to XXXII, Any Back Vol. Agriculturist, Any Two Back Volumes do, Any Three do, Any Four do, Any Five do, Any Six do, Any Seven do, Any Eight do, Any Nine do, Farmer's Boy's Library, Any Back Vol. Agriculturist, Any Two Back Volumes do, Any Three do, Any Four do, Any Five do, Any Six do, Any Seven do, Any Eight do, Any Nine do, Any \$10 Library, Any \$15 Library, Any \$20 Library, Any \$25 Library, Any \$30 Library, Any \$35 Library, Any \$40 Library, Any \$45 Library, Any \$50 Library, Any \$60 Library, Any \$75 Library, Any \$100 Library, Choice of Good Books.

Now For FEBRUARY.

This is a First-rate Month for Making up New Clubs, Completing those already begun, and Securing the Valuable Articles offered in our Premium List.

The Publishers of American Agriculturist and HEARTH AND HOME take pleasure in presenting their new general Premium List for 1874. The Premiums which they have offered in past years have engaged the attention of a very large number of persons of all ages and both sexes. Many thousands have secured Premiums, and very many of these, who at first had small hopes of success, have been themselves astonished at the ease with which they have raised large clubs and secured valuable Premiums.

Here is pleasant and profitable work for all. Boys and Girls, Young Men and Maidens, Middle-aged Men and Women, Farmers, Mechanics, Merchants, Professional Men, Anybody, Anywhere

who wishes to do good and make money, can do both by going to work as here invited by the publishers of these two most valuable journals, American Agriculturist and HEARTH AND HOME. You need only to show specimens of the papers, promise the beautiful Chromos, which are now ready for delivery, according to the publishers' offer, and forward your subscriptions. There is no danger of failure in the enterprise if you go into it with spirit. You may succeed in

Every Premium article is new and of the very best manufacture. No charge is made for packing or boxing any article in our Premium List. The Premiums, Nos. 2 to 8, 27 to 33, 55 to 78, and 81 to 93, inclusive, will each be delivered FREE of all charges, by mail or express (at the Post-office or express office nearest the recipient) to any place in the United States or Territories.—The other articles cost the recipient only the freight after leaving the manufactory of each, by any conveyance desired. Description of Premiums sent free to applicants.

Full Descriptions

of our Premiums are given in a previous number, and will be mailed free to applicants. We have room in this paper only for the following **Descriptive Notes**:

No. 1. — Moore's Floral Set.—This is a beautiful Premium—a complete set of **Ladies' or Children's Garden Tools** for the cultivation of flowers, consisting of a Floral Hoe, Spade, Fork, and Rake. They are made of the best steel and iron, with finely polished hard-wood handles, light, durable, and highly finished, and each set inclosed in a box. They will be found very convenient in the garden and greenhouse, and are pleasing toys for the little folks. Made by the **Moore Manufacturing Company, Kensington, Ct.**

Nos. 2, 3, 4.—Gold Pens: with ever-pointed Pencils, in extension, coin-silver cases.—Premium No. 2 contains the best No. 4 Gold Pen; and No. 3 the best No. 6 Gold Pen, which is the same style, but larger. No. 4 contains No. 7 Gold Pen, in Gold-tipped Ebony Holder. Each pen will be sent in a neat leather case by mail, post-paid. These pens are made by **Geo. F. Hawkes, No. 66 Nassau St.**, and have obtained an excellent reputation. We have known the maker and his goods for many years, and can recommend them.

No. 5.—Ladies' Fine Gold Pen, in Rubber Case, Gold Mounted, with Screw Extension, and Gold Ever-pointed Pencil. A beautiful present for a lady teacher or friend. Same maker as No. 2.

Nos. 6, 7.—Paragon Patent Revolving Pencil.—This is a beautiful Pocket Pencil, which is extended or closed by pulling or pressing the head. They are made with great care, and every Pencil warranted to work perfectly. They are gold-plated, and will last for years. We offer two patterns, one for ladies, with ring for chain, at \$1.50 each, and one of heavier and firmer plate, at \$3.00. Same maker as No. 2.

No. 8.—Payson's Indelible Ink, and Briggs's Marking-Pen Combination.—Payson's Indelible Ink is too well known to need further commendation. It is almost indispensable in the family. Briggs's Marking-Pen has been before the public for fifteen years, and is justly celebrated for all kinds of marking, and particularly for writing upon coarse fabrics. The Pen and Ink are put up in a neat case, being thus portable, always ready for use, and protected from loss or injury by evaporation or breakage.

No. 9.—Cake Basket.—A new pattern, oval-shaped, nicely chased—a very taking, useful, and beautiful table ornament. This, with other articles that follow, is made by the **Lucius Hart Manufacturing Co., of Nos. 4 and 6 Burling Slip, New York City**, and is warranted by them to be of the best triple plate. Mr. Hart, "the veteran Sunday-school man," was engaged in the same place and business for nearly a quarter of a century. We have known him and his work for many years, and have taken pleasure in commending and guaranteeing its value to be as represented. We believe the Company which bears his name is fully sustaining his reputation. The amount of silver upon plated ware depends wholly upon the will and integrity of the manufacturer. We could give nearly as good-looking plated ware for less than half the money.

No. 12.—One Dozen Teaspoons.—No. 13.—One Dozen Table-Spoons.—These are "figured tips," Olive-leaf Pattern, all of the same metal, plating, etc., and from the same makers as No. 9. They are far cheaper than anything we have found at half the price, and are well worth working for.

No. 14.—One Dozen Table-Forks.—The same description and remarks apply to these as to No. 13. We select as premiums only such articles as we can warrant in quality and price. All these articles come from the **Lucius Hart Manufacturing Co.**

No. 15.—Child's Cup.—A beautiful gift for the little one-year-old. It is made by the **Lucius Hart Manufacturing Co.** Triple-plated on the outside and gilded on the inside. It never breaks, and will last for many years—indeed, be a life-keepsake.

No. 17.—Child's Carriage, or Perambulator.—An elegant carriage, handsomely finished, upholstered with reps, has full plate tinned joints, handle tips, side lights, dash rail, panel body, and carpet on the bottom. These carriages are from the well-known manufacturer **C. W. F. Dare, 47 Cortlandt St., New York.**

No. 19.—Doll's Cottage Chamber Set.—A most attractive gift for a little girl. Eight pieces of furniture prettily painted: Bedstead (size $11\frac{1}{2} \times 18$ inches), bureau, table, commode, towel-rack, two chairs, one rocking-chair. From **C. W. F. Dare, 47 Cortlandt St., New York.**

No. 20.—Crandall's Improved Building Blocks furnish a most attractive amusement for children. Churches, Dwellings, Barns, Mills, Fences, Furniture, etc., in almost endless variety, can be built with them, and the structures remain so firm as to be carried about. For developing the ingenuity and taste of children they are unequalled. The Blocks are put up in neat boxes, accompanied by a large illustrated sheet giving various designs of buildings, etc. This is one of the most successful toys ever invented.

No. 21.—Crandall's Masquerade Blocks.—These are put up in boxes, the blocks in each of which will make, by various combinations, 300 different pictures in brilliant colors. They are not injured by washing, and afford endless amusement for children. They are beautiful gifts for the little ones.

No. 22.—Knives and Forks.—These have ebony and metal handles, manufactured by a patent process which unites them so firmly to the blades that they never work loose, and are rendered hot water-proof. The knife blades are silver-plated. Made in the best style by the **Woods Cutlery Co., 55 Chambers St., New York.** For this Premium we will give either the Table, Medium, or Dessert size, as may be specified by the recipient; six knives and six forks, or twelve knives without forks.

Nos. 23, 24, 25.—American Table Cutlery.—We are glad to be able to offer really good articles of American manufacture, such as are competing successfully with the best foreign make. **Messrs. Patterson Bros., 27 Park Row**, who supply us with these articles, are also importers of English goods. They recommend these Knives, manufactured by the **Meriden Cutlery Co.**, as equal to any Cutlery in the market, and their recommendation is a guarantee wherever they are known. We offer two kinds of Knives, and three sizes of each kind. No. 23 have Rubber Handles, which are actually boiling-water proof, so that, if they were accidentally to remain in it for several minutes, or even hours, they would not be injured. The Blades are of the best steel, and warranted. Dessert size, with Forks, sold at \$15. For 24 subscribers at \$1.50, or 80 at \$1, we will give either the medium size or the table size, sold at \$16.00. No. 24 have Ivory Handles, are selected with great care, have Steel Blades, and are beautiful goods. Dessert size, with Forks, sold at \$20.00. For 33 subscribers, at \$1.50, or 110 at \$1, we will send the medium size, sold at \$22.00. For 35 at \$1.50, or 116 at \$1, we will send the Table size, sold at \$23.00. The Forks, which accompany these Premiums, Nos. 23 and 24, are made of genuine Albata, and warranted double-plated with coin-silver. These Forks are furnished to us by Messrs. Patterson Bros. The Carving-Knife and Fork are made by **The Meriden Cutlery Co.**, with the best Ivory, balanced Handles.

Nos. 27, 28, 29, 30.—Pocket Knives.—HERE'S FOR THE BOYS AND GIRLS!—These Premiums are among the most pleasing and useful that we have ever offered. Every boy, and girl too, wants a pocket knife. We give them an opportunity to obtain a most valuable one for merely a little effort. These knives are furnished by the **Meriden Cutlery Co., 49 Chambers St., New York**, whose work is equal to any done in this country or Europe. No. 27 is a neat, substantial Knife, with three blades and buck-horn handle. No. 28 is a still finer article, with four blades and pearl handle. No. 29 is an elegant Knife, with five blades and shell handle. No. 30 is a Lady's Pocket Knife, a beautiful article, with four blades and shell handle.

No. 31.—Mulum in Parvo Pocket Knife.—Boys, Read this. This is a most attractive as well as useful Premium, from the **Meriden Cutlery Co., 49 Chambers St., New York.** It comprises, in one knife-handle, a large and a small blade, a screw-driver, a saw, a strong hook, a nut-cracker, a brad-awl, a gimlet, a corkscrew, a pointer, a slim punch, tweezers, and, in addition to this, it can be used for various other purposes which will at once suggest themselves to any smart boy or man. It is a pocketful of tools weighing but two ounces. The knives will be sent anywhere in our country, post-paid.

No. 33.—Extra Early Vermont Potato.—This remarkable potato is a seedling raised in 1867 from a seed-ball of the well-known Jackson White. It is supposed to have been fertilized from the Garnet Chili, as it resembles many seedlings of that variety. For five years the "Vermont" potatoes have been grown side by side with the Early Rose, both under the same treatment, and have proved seven to ten days earlier than that favorite sort; they are more productive, fully equal to the Early Rose if not superior in quality, flesh very white, dry, and floury, excellent keepers, and in every way a most promising variety. We have made arrangements with **Messrs. B. K. Bliss & Sons, 23 Park Place, New York**, to supply us with the genuine article, to go by mail, post-paid, to any part

of the country. They should go out before freezing weather, but when too late for this we will keep them until warm enough to mail them in the spring. This Premium can only remain open while the supply lasts.

No. 40.—Doty's Improved Clothes Washer, with the Metropolitan Balance Weight. Over seventy-five thousand families in the United States are using the Doty Washing Machine, and we believe the improved machine has no superior. The "help" use it and like it. Send for descriptive circulars to **B. C. Browning, 32 Cortlandt St., New York**, or to **Metropolitan Washing Machine Co., Middlefield, Ct.** It goes cheaply by freight or **Ex.**

No. 45.—A Good Watch.—The Watches made by the **American Watch Co., Waltham, Mass.**, have peculiarities of excellence which place them above all foreign rivalry. The substitution of machinery for hand labor has been followed not only by greater simplicity, but by a precision in detail, and accuracy and uniformity in their time-keeping qualities, which by the old method of manufacture are unattainable. A smoothness and certainty of movement are secured which proceed from the perfect adaptation of every piece to its place. The extent of the Waltham establishment, the combination of skilled labor with machinery perfect and ample, enable them to offer watches at lower rates than any other manufacturers. Their annual manufacture is said to be double that of all other makers in this country combined, and much larger than the entire manufacture of England. The mechanical improvements and valuable inventions of the last fifteen years, whether home or foreign in their origin, have been brought to their aid, and the presence of nearly 800,000 Waltham Watches in the pockets of the people is the best proof of the public approval. We offer a Silver watch, jeweled, with chronometer balance, warranted by this Company as made of the best materials in the best manner, and in pure coin-silver "hunting" case; weight 3 oz. This watch we offer as one of our Premiums, with the fullest confidence. Upon the movement of each of these watches will be engraved, "AMERICAN AGRICULTURIST. MADE BY THE AMERICAN WATCH CO., WALTHAM, MASS."

No. 46.—Ladies' Fine Gold Watch.—This elegant Premium will delight our friends who may receive it. Our arrangement with the **American Watch Co.** (see No. 45 above) includes these beautiful gold watches. They are full-jeweled, in 18-carat "hunting" cases, warranted to be made of the best materials, and possessing every requisite for a reliable Time-Keeper. Upon the movement of each Premium Watch will be engraved "AM. AGRICULTURIST. MADE BY THE AM. WATCH CO., WALTHAM, MASS."

No. 48.—Double-Barrel Gun; OR FOWLING PIECE.—These guns are the genuine London "Twist" barrel, Patent Breech, Bar Lock, ebony ramrod, and in all respects desirable. Their caliber and length of barrel vary, and may be ordered to suit the kind of shooting to be done. They are furnished for this Premium by **Messrs. Cooper, Harris & Hodgkins, 277 Broadway**, well known as one of the most reliable and best houses in their line of business, and they highly recommend this particular gun, and guarantee it in every respect. It is from one of the oldest and most favorably known English manufacturers. The price is not put on in fancy carving and plating for show, but in the gun itself. This Premium includes Gun, Powder-Flask, Shot-Pouch, and Wad-Cutter.

No. 49.—Remington's Sporting Breech-Loading Rifle.—The Rifle offered as this Premium has a 30-inch steel barrel, and can be of any weight from 8 to 12 lbs., and of any caliber from $22/100$ to $50/100$, as may be desired. Ammunition is extra, and at prices varying in accordance with the caliber. These rifles are manufactured by the noted firm of **E. Remington & Sons, Nos. 281 and 283 Broadway, New York**, whose reputation is world-wide, and who stand in the front rank of manufacturers of fire-arms.

Nos. 81 to 92.—Good Libraries.—In these premiums, we offer a choice of Books for the **Farm, Garden, and Household.** The person entitled to any one of the premiums 81 to 92 may select any books desired from the list of our books published monthly in the *American Agriculturist*, to the amount of the premiums, and the books will be forwarded, Post or Express paid. Let the farmers of a neighborhood unite their efforts, and through these premiums get an agricultural library for general use. See Table List of Books in advertising columns.

No. 93.—General Book Premium.—Any one sending 25 or more names, may select books from our list to the amount of 10 cents for each subscriber sent at \$1; or 30 cents for each name sent at \$1.20; or 60 cents for each name at \$1.50. This offer is only for clubs of 25 or more. The books will be sent by mail or express, prepaid through, by us. See List as in No. 81.

Disease in Fowls' Legs.—"W. H. H.," Alton, Ill. Sores in the joints of a fowl's legs which eat away the joint in two weeks, must arise from a very serious constitutional disturbance, and any remedy is doubtful. It might be well to try a dose of sulphate of soda as large as a pea in a pill of bread or dough each day for a few days, and changing the food. The sores should be washed daily with warm soap and water. Closely bred fowls are more frequently thus troubled than others, and a change of blood would be desirable.

Co-operative Store.—"T. E. E.," Plainfield, Ind. The managers of the co-operative store in Sedalia, Mo., would doubtless be glad to give—if requested—information as to their plan of business to persons who desire to organize such an institution. A town of 1,500 inhabitants ought to present a field large enough for such a business.

For a Jumping Colt.—"J. H.," Clarkson, Iowa, says if a halter is put upon a colt, and the end of the halter strap passed between the forelegs and fastened to a strap around the horse so that he can not raise his head higher than a level with his back, he can not jump, and it will not interfere with his feeding.

The Potato Disease.—Early last year an Englishman whose name has escaped us offered a handsome sum as a prize for the best essay on the potato disease and its cure. The council of the Royal Agricultural Society, in whose hands the matter was placed, do not advise making any award. They recommend, however, that a sum of money be appropriated for the careful investigation of the potato fungus (*Peronospora infestans*), which is now admitted to be the cause of the trouble. What a chance here is for the remarkable microscopist of our remarkable Department of Agriculture.

A Heavy Ox.—The Butchers' prize for the heaviest bullock at the Birmingham (Eng.) Fat Cattle Show was this year awarded to a cross-bred ox out of a polled Scotch cow by a short-horn bull. The animal weighed 2,666 pounds. Last year the first prize at the Smithfield Fat Cattle Show was taken by a polled ox. This certainly shows well for the feeding qualities of the polled stock.

Scratches.—"T. G. P.," Hessville, West Va. Scratches is an inflammatory suppurative action of the skin of a horse's heels and hind legs. It is often very difficult of cure. At other times it readily submits to very simple treatment, such as washing the parts quite clean with a solution of one dram of carbolic acid to a pint of water. After the washing the legs are wiped quite dry with a soft cloth, and anointed with glycerine as often as is needed to keep the skin from becoming dry. At the same time the horse should have half an ounce to an ounce of sulphate of soda in the feed twice a day. Care must be taken to keep the legs clean and dry and free from mud, which is in many cases the direct cause of the trouble.

Measure for Hay.—"W. H. W.," Glendale, Ky. The estimates for the measurement of hay in the mow are all intended for solidly packed hay, and the average of the whole mow. The bottom of a deep mow will be heavier, and the upper part will be lighter than the centre, which represents the average of the whole. The same refers to a stack.

Mulum in Parvo.—"E. W. T.," Wicomico Co., Md. Peruvian guano would be a very good fertilizer for oats, as will hen manure mixed with earth, but it should be used more liberally than guano. The best fertilizer for corn is the dried blood manure; we have seen some extraordinary results from it. It may be procured in Baltimore. No one can justly expect much of a corn-sheller for one dollar. A dollar's worth of such an article would be very little and yet it might be worth its cost. Artificial hatching of eggs is perfectly successful so far as to produce chickens; the operation always fails at this point because the chickens can not take care of themselves and they die faster than they were hatched. A hundred light Brahma fowls will cost from \$250 upwards if really good ones.

Concrete Buildings.—"H. H. S.," Los Angeles, Cal. The article upon concrete buildings appeared in the *Agriculturist* of March and August, 1872. As these numbers may be procured in any desired quantity it is not necessary to reprint the article.

Diseased Udder.—"J. W. P.," Bureau Co., Ill. A gathering upon the udder of a cow which finally breaks and forms a running sore is as likely to have occurred from a blow, a kick, or a punch with an

other cow's horn as anything. It should now be treated by injecting into the sore with a syringe a solution of one dram of carbolic acid in a pint of water, each morning and evening, until the offensive discharge ceases and it begins to heal in a healthy manner, after which it should be cleansed daily with the same solution until healed.

Pipes for Drains and Irrigating.—"H. H. S." Earthen pipes for drains have been made for many years; there is no patent right upon them. Common drain tiles may be used for irrigating by turning the water into them, which would escape at the joints. It would be simply the reverse of draining. We shall be happy to receive the communications referred to.

Buff Cochins.—"W. H. B." Buff Cochins fowls are included amongst the profitable egg-producers. Nevertheless there are some varieties, as the Spanish and the Leghorns, which are more prolific in this respect than the Cochins. The Brahmas are also preferable to the Cochins, standing, in our opinion, next to the Leghorns, especially as winter layers.

Oil Meal.—"C. L.," Lancaster Co., Pa. Oil meal may be kept perfectly well in a dry place. If in large bulk it will heat, and if the place is damp it will mold. It is best kept in flour barrels or in a bin in the granary, and if it shows any signs of heating it should be shoveled over or transferred to another bin. Two quarts daily will be a fair allowance for a cow. One pint daily is enough for a calf, and a pint in each feed will be enough for a horse in addition to his other feed.

Foot and Mouth Disease in Sheep.—"Englishman," Lynchburg, Va. The symptoms described, viz: sores around the coronet of the hoof and for two inches up the leg, and between the cleft of the foot, also sores upon the lips appear to point to Aphthæ, or what is known as the foot and mouth disease. At the same time it may be only a vesicular eruption which frequently occurs upon the feet and which is conveyed to the mouth by contagion in consequence of the animal licking the sores upon the feet. We would wash the feet and touch the sores upon the lips with the following, viz: 2 drams chloride of zinc, 1 oz. tincture of myrrh dissolved in one pint of water. Each sheep should take two ounces of epsom salts with a little ginger or a few tea-spoonfuls of peppermint water. The feet must be kept well washed with the solution and the sheep be kept upon a dry barn floor until recovered.

Windmill.—"L. D. S.," Huron, Ohio. For information as to windmills write to the United States Windmill Company, Batavia, Illinois.

Poultry for Profit.—"A. J. W.," Toledo, Ohio. The most profitable breed of poultry, we believe to be the light Brahmas; they are good layers, mature early, are heavy bodied when mature, have good flavored flesh, are good sitters and mothers, are hardy, very docile and not inclined to wander, can be kept inside of a fence five feet high or less, are handsome, and are salable either living or dead. Wright's and Lewis's poultry books are useful works upon this subject.

Harrowing Corn.—"J. P. L.," Ringwood, N. C. When the Thomas harrow is used to harrow young corn it is run indiscriminately over the field, the young corn not being injured excepting occasionally a stalk is torn out. But no other harrow should be used for this purpose in this way. The usual corn harrow is a V harrow which has the central tooth removed; it is passed over the row so that the plants are passed over by the space left by the removed tooth, and each side of the row is harrowed. Handles are used to guide it.

Sheep Farming in Texas.—"Stone.," Chicago. The only part of Texas now left for cattle and sheep feeding upon the range is the western part of the state. In the East settlements are becoming too thick for the comfort of cattle men. For information as to lands the Commissioner of Public Lands, Austin, Texas, should be written to.

Darnel.—This grass (*Lolium temulentum*), a native of Europe, is more or less introduced into this country. It has long enjoyed the distinction of being the only grass that produced seeds having poisonous qualities. This character was attributed to it by both agriculturists and botanists of early times, and it has been kept stereotyped in all the books upon grasses. Mr. Alexander Stephen Wilson has been experimenting with Darnel, and has presented his results in two papers read before the Botanical Society of Edinburgh. In his last paper he stated that he has eaten it mixed with wheat and oat-meal in very much larger quantities than it would be naturally mixed with those grains, in hot and cold

bread, taking over four ounces of Darnel in a day, without experiencing any effects whatever.

The Poitou Ass.—"H. P.," Dover, Del. To import a Poitou jack would cost a large sum of money. By importing several, each one would cost less in proportion. An animal may be purchased in France for from \$1,000 to \$2,000, as they are very highly valued and are reluctantly sold. It would not be safe to purchase unless in person, so that there would be traveling expenses back and forth, say \$400, and freight of the jack, which would be at least \$150. Still as these animals are exceedingly valuable the importation of a pair of asses would undoubtedly be a benefit to the public if it should not be profitable pecuniarily.

Goats for Milk.—"S. H.," Piereeville, Ind. We do not know where milk goats that are able to milk four quarts a day could be procured. That is about the average yield of our common cow. If ordinary goats yielding a fourth of that quantity would be desirable, a thousand or two could be purchased in the cities of New York, Brooklyn, and Philadelphia for about the price of common sheep, and their removal would be a relief to the inhabitants of those cities who have gardens and shade trees, upon which these creatures love to depredate.

Oleo Margarine.—"A. R. F.," Kansas City, Mo. We would repeat what we have already said in noticing the fact that suet is manufactured into so called butter, that the product is not butter in any sense, nor do we believe for a moment that the manufacturers of the stuff can ever induce people knowingly to purchase it. If it is put into the market as butter it is a fraud, and we would not advise any parties to go into a fraudulent business, but on the contrary to avoid it although it might be a profitable one.

The Burlington and Missouri Railroad Company have sold along their line in Iowa and Nebraska, within thirty-three months, 478,938 acres to 4,525 purchasers, on ten years' credit and six per cent interest. On sales made since 1873 no part of the principal is payable until the end of four years, while twenty per cent is deducted from land prices for prompt improvement.

The Volinia Farmers' Club sends us its printed programme for 1874—which shows a judicious variety of discussions and field trials for nearly every month in the year. We assume that this club is held at Volinia, Mich., but there is nothing on the programme to show that it is not at Volinia, Japan. We hope our Volinia friends will not take this criticism amiss, as we only use their oversight to say to the officers of societies and clubs that a large share—half, if not more, of the printed circulars and communications that come to us mention neither county nor State, and if the post-mark happens, as is usually the case, to be indistinct, we have no clue to their whereabouts.

Leather and Farmers' Refusings.—"H. F. B.," Sing Sing, N. Y. All the refuse parts of the hide of an animal are valuable for fertilizing purposes, as is also the liquor in which such refuse has been hoiled. Long steaming under great pressure is needed to make bones easily crushed into powder, and then they are not so valuable as the raw bone-dust, because they have lost all their nitrogenous matter. Liquid manure is best applied by means of a spreader such as has been already described in the *Agriculturist*.

Crop for an Orchard.—"G. R. B.," Seymour, Ind., has an apple orchard just in bearing. He wants to know whether to cultivate it with some crop or sow it to grass, and what kind of grass or crop is the best one.—"G. R. B." should consider that it is unfair to land to ask too much of it. As trees are usually planted in orchards, the fruit is all the crop that should be taken from the land; if potatoes or other root crops are grown they should be so well manured that the land will lose nothing. Perhaps the best treatment for an orchard is to sow it to clover and pasture hogs upon it. This will keep the soil constantly improving and have the advantage of disposing of the windfalls.

Worms in a Cow.—"S. B. D.," Downieville, Cal. Cows are sometimes, especially when young, troubled with small, thread-like worms of two varieties. The irritation of the skin, which causes the cow to rub the hair off, may be due to the disturbance of the system consequent upon the presence of the worms. The remedy is to give before feeding in the morning, one pint of linseed oil, two ounces of oil of turpentine, with half a pint of infusion of quassia mixed together. Repeat the dose in ten days. Salt regularly given is almost a sure preventive of internal parasites in all farm stock.

TO FARMERS & PLANTERS.



DOUBLE REFINED POUDETTRE for sale in lots to suit customers. This article is sold for half the price of other fertilizers, and is cheaper for Cotton, Corn, Tobacco, and Vegetables than any other in the market. Price, delivered on board in New York City, \$25 per ton. Ask attention to the following testimonials:

CHARLES A. MESSENGER, Providence Co., R. I., writes: "The Double-refined Poudre I bought of you has given satisfactory returns, and I consider it the best of anything I can use for an early crop."

THOMAS W. LATHAM, Providence Co., R. I., writes: "I would rather have your Double-refined Poudre than any phosphate I ever used. Where I used it on Potatoes it was far ahead of any other manure."

L. H. SHELDON, Sup't of the New Jersey State Reform School, writes: "We have used Poudre for several years upon our farm crops, and for the money invested we have found nothing that has done us so much service."

S. J. KELLY, Burlington Co., N. J., writes: "I used Double-refined Poudre on Rutabaga Turnips alongside of Peruvian Guano and Hen Manure. Where the Poudre was applied the increase was thirty per cent over the others."

WILLIAM H. CADY, Ocean Co., N. J., writes: "I used Poudre on Corn, Sweet and round Potatoes, Onions, and Lima Beans. It brought forward my crops two weeks earlier. I think it the best manure I ever used, giving better results than Peruvian Guano, at much less cost."

VAN ANTWERP AND VAN BUREN, Montgomery Co., N. Y., writes: "Poudre has been used in this locality for ten years past, mostly on Corn, and those who have used it say they have from 1/4 to 1/2 more Corn by using the Poudre."

W. F. GERKIN, of Essex Co., N. Y., writes: "I have used the Double-refined Poudre for the last five years, and I consider it the cheapest fertilizer I can buy—giving the best results for the cost."

MILTON STRONG, Suffolk Co., N. Y., writes: "I gave Poudre a thorough trial this year, using it upon Corn, Potatoes, Lima Beans, Tomatoes, and Vines, and I have never raised better crops. My Corn will yield 100 bushels of ears per acre, and my garden was the surprise and admiration of all who saw it."

HENRY T. HORTON, Cheshire Co., N. H., writes: "I find, from experiments made last year, the Double-refined Poudre is the cheapest fertilizer to use on Tobacco. I put it beside Peruvian Guano with equal cost of both, and the Tobacco was 30 per cent better where I used Poudre."

W. H. REMINGTON, Hartford Co., Ct., writes: "I have used Poudre on Corn, Potatoes, and Tobacco. There was but one piece of Corn in the place equal to mine, and that had 30 loads of manure per acre and mine none. The Tobacco started as soon as set and grew luxuriant."

WM. S. POMEROY, of Hartford Co., Ct., writes: "I have used the Double-refined Poudre for several years on Tobacco, and I think it one of the best fertilizers made for this crop."

A Pamphlet giving full directions, etc., sent free on application to
JAMES T. FOSTER,
66 Cortlandt Street, New York.

GENUINE Peruvian Guano.

FARMERS, AGRICULTURISTS, and DEALERS in Fertilizers have now an opportunity of obtaining this valuable manure in small or large lots, at importers' prices, by applying to the Special Agency just established for the purpose of delivering Genuine Peruvian Guano to consumers at any accessible port or railway station in the country. Full particulars given in circular mailed free on application to

R. BALCAZAR,
No. 53 Beaver Street, New York.

REFERENCES BY PERMISSION:
Messrs. HOBSON, HURTAO & Co., Financial Agents of the Peruvian Government, 52 Wall Street, New York.
MOSES TAYLOR, Pres. National City Bank, 52 Wall St., N. Y.
J. C. TRACY, Esq., Peruvian Consul, 26 1/2 Broadway, N. Y.



Buy the Best Fertilizers.
Send for Agricultural Almanac for 1874.

H. B. GRIFFING,
58 and 60 Cortlandt Street, New York.

FISH GUANO FOR SALE.
Send for Circular. **H. FISK, Southold, L. I.**

FRUIT FARM for sale. 62 acres; 50 in fruit trees, 13 in berries, 6 in grapes, 2 for vegetables. Soil very rich. Market No. 1. One mile of the crossing of three railroads. No. 1 horse, barn, etc. Address: **JAS. B. CURENS, Mattoon, Ill.**

CARHART'S PATENT Two Horse Pulverizing Cultivator

IMPROVED.

The Depth can be Regulated by a simple Movement of the Lever, convenient to the Hand of the Driver.

WHY IT IS THE BEST CULTIVATOR.

Because it Draws Lighter than any Wheel Cultivator. Costs one-half less. Will Exterminate Quack and Thistles. Can be run close to a plant or a tree without injuring it. Cultivates Hops successfully. Cultivates Corn first time effectually. Runs steady, being drawn with a pole. Will Pulverize sod with a proper adjustment of the teeth. Is Strong and Durable. Sells readily, and every sale brings another order from a neighbor, with an unsolicited testimonial filled with enthusiasm in regard to its merits.

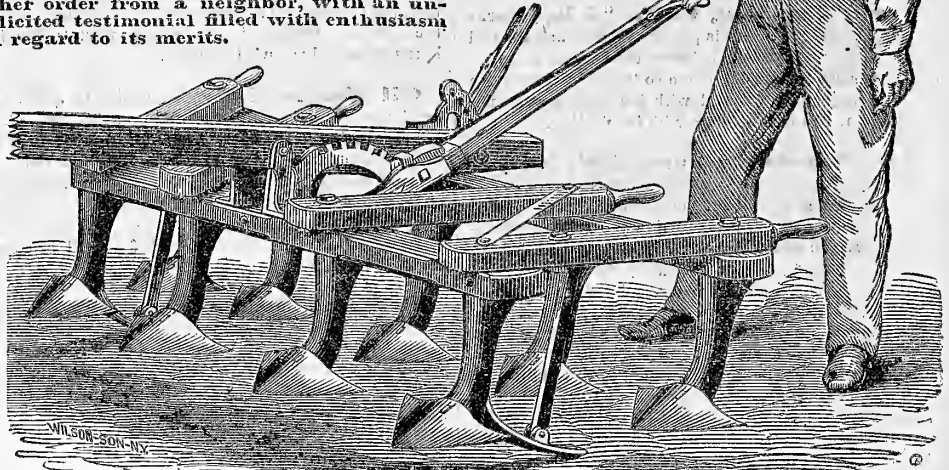

Better worth the money, and will pay for itself quicker than any implement ever placed upon the farm.

Price only \$22 Complete.

We will make the following liberal offer for the next three months, in order to introduce this Cultivator where it has heretofore been unknown. Viz.: To any practical farmer who will act as agent we will send one New Improved Cultivator at 25 per cent discount from above price when the cash accompanies the order, and if it does not prove to be all that it is represented we will refund the money, and as evidence on our part of the faithful performance of the guarantee we refer to our forty years' reputation as manufacturers.

Send for Descriptive Circular with testimonials. We furnish THISTLE TEETH, as shown in cut, or the REVERSIBLE OVAL TEETH, as preferred. In ordering, please state which teeth are desired.

BRADLEY MANUFACTURING CO., Syracuse, N. Y.

Samples from B. E. Hale & Co., 56 and 58 Park Place, N. Y. Sole Agents for Eastern States.

BUILDING PAPER!
FOR SHEATHING, ROOFING, DEAFENING, CARPET LINING, AND PLASTERING!

Samples from Rock River Paper Company, Chicago, Ill.

Bradley's AMERICAN HARVESTER

Will cut any grain that grows, and in any condition.

BRADLEY'S ACME MOWER

Has Inclosed Gearing, Center Draft, Perfect Balance, Single or Changeable Spools, Perfect Floating Bar, Cushioned Pitman, Self-adjusting Journals. Draft 125 lbs. Has more good points and less complication than any mower in the world.

Agents wanted. Send for descriptive circulars.

BRADLEY MANUFACTURING CO.,
Syracuse, N. Y.

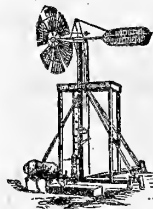

Halladay's Improved Wind-Mill.

PERFECTLY Self-Regulating. The Best, Cheapest, most Durable and Popular Mill made. Manufactured under the immediate supervision of Inventor. 18 years. Two million dollars' worth new in use. Send for Catalogue.

U. S. WIND ENGINE & PUMP CO.
BATAVIA, ILL.

FARM FOR SALE.—The Fruit and Truck Farm of D. H. Brown, known as "Cherry Lawn," 60 acres. Good buildings. Plenty of large and small fruit. Well laid out. 1 1/2 miles from the center of New Brunswick (about 20,000 inhabitants). On the N. J. E.R., between Phila. and New York, 80 miles from New York. Fine for Trucking, Fruit Growing, or Nursery, or gentleman's residence. Must be seen to be appreciated. Full particulars on application (person or letter).
D. H. BROWN & SONS, 20 HIRAM STREET,
New Brunswick, New Jersey.

FOR SALE—CHEAP.—Two Farms, one 48, the other 260 acres. The greater portion is of the best of bottom land; suitable for any kind of produce; plenty of good water; comfortable dwelling. Small orchard, with the best of fruit trees. Near the market. One mile from R.R. station. 40 miles from St. Louis. Address: **JOHN SCHMIDT, Robertsville P. O., Franklin Co., Mo.**

The Sugar Maker's Friend



Address C. C. POST, Manuf. and Patentee, Burlington, Vt.

MARTIN'S IMPROVED Brick Machine.

Adopted and used by the leading Brick manufacturers. Made and sold by the **AMES MFG CO., Chicopee, Mass.**

BUCKEYE DRIER, BAKER AND FEEDSTEAMER

For full particulars, address **ENGLE, KELLER & CO., Lancaster, Pa.**

FIRST Premiums awarded by Amer. Inst., 1870. **MICROSCOPES.** Illustrated Price-List sent free on application. **MAGIC LANTERNS.** Catalogue, priced and illustrated, sent free. **T. H. McALLISTER, Optician, 49 Nassau-st., N. Y.**

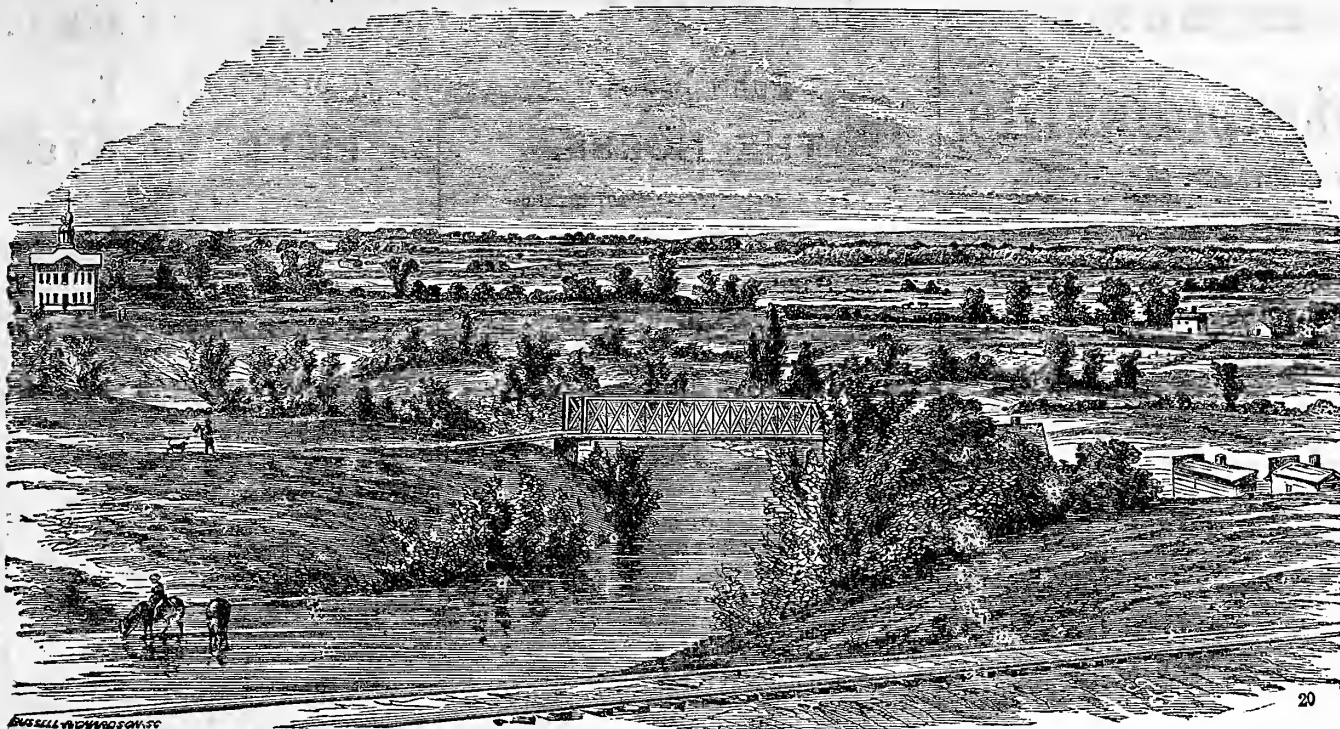

SALT CREEK, AT ASHLAND, NEB.—LOOKING TOWARD THE PLATTE HILLS, FROM THE MILL HILL.

**IF YOU WANT A FARM OR HOME,
YOU SHOULD BUY OF THE**

BURLINGTON AND MISSOURI RIVER RAILROAD CO.

- BECAUSE**—Their prices are low, ranging for the best land from Three to Ten Dollars per acre.
- BECAUSE**—No payments are required of the purchaser for four years, except interest at six per cent.
- BECAUSE**—After the expiration of four years, **SEVEN YEARS** are allowed for payment of the principal.
- BECAUSE**—You are not obliged to go into a wilderness, but into a well-settled State, the population of which is rapidly increasing.
- BECAUSE**—The mildness of the climate and fertility of the soil is such that the settler can pay for his farm from the products raised upon it long before the time when the principal becomes due.
- BECAUSE**—Failure of crops from drouth is unknown.
- BECAUSE**—Large allowances are made upon fare and freight, thus giving low rates on both to purchasers of this Company's lands.

AND YOU SHOULD BUY THIS YEAR.

BECAUSE—Purchasers during 1874 who cultivate one-half their land within two years from their purchase are allowed a reduction of twenty per cent on the price of their land.
LARGE DISCOUNTS also, **FOR CASH**, within One, Two, or Three Years.
 Send for Circulars, with full information on all points, to

GEO. S. HARRIS, Land Commissioner,
 At Lincoln, Nebraska, for land in Nebraska. At Burlington, Iowa, for land in Iowa.
JAS. R. WOOD, General Agent, 59 Clark St., Chicago, Ill.

Or to **W. D. COWLES**, General Agent, 317 Broadway, New York.



REMINGTON'S

Sporting, Hunting, and Target
Breech-Loading

Rifles & Shot Guns.

Also, Revolving, Repeating, Deringer, and
Vest Pocket

PISTOLS and RIFLE CANES.

OUR

Double-Barrel Breech-Loading Gun

IS NOW READY.

The best ever offered, containing all the most desirable features of the best imported, together with some valuable improvements peculiar only to this gun. Top Snap action, half-cocked, breech opened and shells extracted by one motion.

E. REMINGTON & SONS,

281 and 283 Broadway, N. Y.

OR, ARMORY, ELION, N. Y.

CUT THIS OUT AND SEND FOR ILLUSTRATED
PRICE LIST.

AGENTS We have more experienced agents than any other House. They make more money. OUR COMBINATION TAKES. Employment for ALL at home or traveling. Large CASH wages. Superior outfit. Send for specimens, circulars, terms, our new ideas to
WATERS & CO., Pub's, Chicago.

Michigan State Agricultural College,

LANSING, MICH.

The next term opens with examination for admission

FEBRUARY 25th, 1874.

For Catalogues, or for any particulars, address

GEO. T. FAIRCHILD, Pres. pro tem.

Civil Engineering School

OF UNION COLLEGE, SCHENECTADY, N. Y.

Thorough course of instruction and field practice. Unrivalled collection of apparatus. Tuition, \$30 per term. Assistance rendered deserving students. For special information, address Prof. C. STALEY. For information concerning the College courses, Classical, Scientific, and Ecclesiastical, address
E. N. POTTER, President.

TELEGRAPH INSTITUTE.

YOUNG MEN AND LADIES qualified for practical operators at the Buffalo Telegraph Institute and City Line Telegraph. Every graduate secures a position. The largest and most complete in America. Address for Catalogue
C. L. BRYANT, Supt., Buffalo, N. Y.

AGENTS WANTED. GRAND BOOKS!

Cyclopaedia of Things Worth Knowing. 25,000 wants supplied. All you want to know about Farming, Gardening, Mechanics, Housekeeping, etc. etc. **THE POPULAR FAMILY BIBLE.** With Bible Dictionary and 500 Illustrations. The handsomest Bible made. **THE VOICE OF GOD.** A beautiful volume for every home. Terms, circulars, etc. **MILLER'S BIBLE & PUB. HOUSE.** 1102 & 1104 Sansom St., PHILADELPHIA, PA.

NEW YORK DAILY WITNESS,

\$3 a Year, 75 Cents a Quarter.

NEW YORK WEEKLY WITNESS,

SIZE OF N. Y. TRIBUNE,

\$1 a Year, or 25 Cents per Quarter.

Send for Sample Copies.

THE ANIMAL KINGDOM.

The American Society for the Prevention of Cruelty to Animals, of which Mr. Henry Bergh is President, is performing a work which must meet the approval of all right-thinking people.

THE ANIMAL KINGDOM

is a Journal published under the auspices of this Society, and is devoted exclusively to the welfare of our humble fellow creatures—the dumb animals. It is filled with interesting stories, sketches, etc., and has among its contributors Henry Ward Beecher, Wayne Hovey, Whittaker, Russell, Mrs. Wallace, and other charming writers. Those who feel an interest in the cause it advocates can receive the paper by inclosing one dollar, the yearly subscription, and addressing **THE ANIMAL KINGDOM, 210 East 13th St., New York.**

WATERS' ORCHESTRAL ORGANS.

entirely new. They are not only original in design, but are also new in their musical construction, producing more power, and at a lower price, than anything ever before accomplished in this line. It has all the superior qualities of the concert organ—"the soul-stirring imitation of the human voice," etc., intensified, or with greater power, making it not only an elegant and powerful parlor organ, but also admirably adapted for Churches, Schools, and Lodges. Terms liberal. Send for the new catalogue. A large discount to Ministers, Churches, Schools, Lodges, etc. Agents wanted.
HORACE WATERS & SON,
 481 Broadway, New York.

20 Sheets of Choice Music, \$1.00.

Why throw away money on high-priced Music when you can select from our Catalogue of 700 pieces? Any 20 Half-Dime, or 10 of Dime Series, mailed on receipt of One Dollar. Sold by all booksellers, and can be ordered through any newsdealer. Send stamp for Catalogue. Address
BENJ. W. HITCHCOCK, Publisher,
 439 Third Avenue, New York.

The Mystery OF Metropolisville,

By EDWARD EGGLESTON,

Author of "The Hoosier School-Master," "The End of the World," etc.

FINELY ILLUSTRATED.

NOTICES BY THE PRESS.

If by "the American novel" we mean one which portrays graphically those features of American life which are distinctly American in that they are developed nowhere else—which catches up the expression and reflects the character of the ideal and unexaggerated American man and woman—then we may as well give over seeking for it, for it has come, and Edward Eggleston is its author. . . . Truthful characterization, a ready humor, a graphic style, and a skillful use of the Hoosier dialect combine to make *The Mystery of Metropolisville* a vivid picture of the times and scenes with which it has to do. We award Mr. Eggleston the palm as the most characteristically American writer of the day.—*Boston Journal*.

The story is told with much spirit.—*Pittsburgh Leader*.

It is a good story, told with vim and naturalness.—*Daily Commercial*, Wilmington, Del.

The plot of the story is very simple, but the happy faculty the author possesses in delineating border life is used to capital effect.—*Weekly Advertiser*, Portland, Me.

It is finished better than either of the former ones ("Hoosier School-Master" and "End of the World"), and has less of the preacher and more of the novelist in it.—*Springfield Republican*.

It is a very bright and readable book.—*Liberal Christian*, New York.

The tendency of the book will be to make a brave, true life honorable, and to make "dleness, hypocrisy, and religion odious.—*Methodist Recorder*, Pittsburgh, Pa.

It is marked by power, close observation, and has some remarkably well-drawn characters.—*Globe*, Boston.

It will be read with general interest, and start the tears and risibles alike.—*Commonwealth*, Boston.

At intervals a writer comes to the surface whom everybody wants to read, and we doubt whether either Dickens or Mrs. Stowe took stronger hold on the popular heart than has the author of these hearty, home-life sketches. In the present volume he greatly enlarges his sphere, taking a widely different class of characters and topics in hand than was attempted in the former volumes. His sterling personal character gives weight and worth to whatever he sends forth.—*Methodist Home Journal*, Phila.

He (the author) particularly excels in treating of certain phases of American manners, and this is the main task which he wisely places before himself.—*Daily Palladium*, New Haven.

All the characteristics of Western life are well illustrated in this racy volume—the rough and the smooth, the coarse and the fine.—*State Republican*, Lansing, Mich.

The story is well and truthfully told, and has one merit so often sadly wanting in modern literature—it is entirely free from all objectional immorality and vice, and will no doubt become immensely popular.—*Daily Chronicle*, Washington, D. C.

CONTENTS.

Preface.—Words Beforehand.—Chapter I. The Autocrat of the Stage-Coach.—2. The Sod Tavern.—3. Land and Love.—4. Albert and Katy.—5. Corner Lots.—6. Little Katy's Lover.—7. Catching and Getting Caught.—8. Isabel Marley.—9. Lovers and Lovers.—10. Plausaby, Esq., takes a Fatherly Interest.—11. About Several Things.—12. An Adventure.—13. A Shelter.—14. The Inhabitant.—15. An Episode.—16. The Return.—17. Sawney and his Old Love.—18. A Collision.—19. Standing Guard in Vain.—20. Sawney and Westcott.—21. Rowing.—22. Sailing.—23. Sinking.—24. Dragging.—25. Afterwards.—26. The Mystery.—27. The Arrest.—28. The Tempter.—29. The Trial.—30. The Penitentiary.—31. Mr. Lorton.—32. A Confession.—33. Death.—34. Mr. Lorton's Courtship.—35. Unbarred.—36. Isabel.—37. The Last—Words Afterwards.

ILLUSTRATIONS.—By FRANK BEARD.

His Unselfish Love found a Melancholy Recompense.—The Superior Being.—Mr. Minorkey and the Fat Gentleman.—Plausaby sells Lots.—"By George! He! he! he!"—Mrs. Plausaby.—The Inhabitant.—A Pinch of Snuff.—Mrs. Ferret.—One Savage Blow full in the Face.—"What on Airb's the Matter?"—The Editor of "The Windmill."—"Git up and Foller!"

Price Postpaid - - - - \$1 50

ORANGE JUDD COMPANY,
245 BROADWAY, NEW YORK.

SUPERIOR STANDARD WORKS.

Published by ORANGE JUDD COMPANY.

THE HORSE.

FRANK FORESTER'S HORSE OF AMERICA.

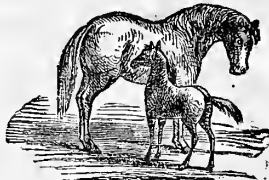

By HENRY WM. HERBERT.

Revised, corrected, enlarged, and continued to 1871, By S. D. and B. G. BRUCE.

Always an ACKNOWLEDGED STANDARD, and now the most COMPLETE and AUTHENTIC Work on the HORSE. With steel-engraved portraits of Thirty of the most famous

REPRESENTATIVE HORSES, including pedigrees, histories, and performances.

Two superb royal octavo volumes of upward of 1300 pages. Post-Paid, Ten Dollars.



WALLACE'S American Trotting Register.

CONTAINING ALL THAT IS KNOWN OF THE PEDIGREES OF TROTTING HORSES,

their ancestors and descendants, with a record of All published performances in which a mile was trotted or paced in 2.40 or less, from the earliest dates until the close of 1868, and a full record of the performances of 1869 and 1870.

Giving complete Summaries of over 6,000 Contests.

With an INTRODUCTORY ESSAY on the true origin of the American Trotter. And a set of Rules for the government of all trials of speed. By J. H. WALLACE, compiler of Wallace's American Stud-Book. Royal octavo.

Post-paid, Five Dollars.

WALLACE'S AMERICAN STUD-BOOK.

VOL. ONE. BEING A COMPILATION OF THE PEDIGREES OF AMERICAN AND IMPORTED BLOOD HORSES,

from the earliest records, with an APPENDIX of all named animals without extended Pedigrees prior to the year 1840. And a SUPPLEMENT, containing a history of all Horses and Mares that have trotted in public from the earliest trotting races until the close of 1866. By J. H. WALLACE. Royal octavo of over 1000 pages elegantly bound in extra cloth, beveled boards, and splendidly illustrated.

Post-paid, Ten Dollars.

Horse Portraiture. — BREEDING,

REARING, AND TRAINING TROTTERS. [Preparations for Races, Management in the Stable, on the Track, Horse Life, etc.] By JOSEPH CAIRN SIMPSON. Post octavo. Post-paid, \$2.50.

FIELD SPORTS.



Frank Forester's Field Sports.

Embracing the Game of North America, Upland Shooting, Bay Shooting, Wild Sporting of the Wilderness, Forest, Prairie, and Mountain Sports, Bear Hunting, Turkey Shooting, etc. 13th edition, revised and illustrated. Two post octavo volumes. Post-paid, \$6.00.

Frank Forester's Fish and Fishing.

100 engravings. Embracing a full illustrated description of the Game Fish of North America; Trout and Salmon Fishing; Shoal Water and Deep Sea Fishing; Lake and River Fishing; Trolling, Fly Fishing, etc. 12th edition. One post octavo volume. Post-paid, \$3.50.

Frank Forester's Complete Manual

For Young Sportsmen, of Fowling, Fishing, and Field Sports. With directions for handling the Gun, the Rifle, and the Rod. Art of Shooting on the Wing. The Breaking, Management, and Hunting of the Dog. The varieties and habits of Game. River, Lake, and Sea Fishing. Post octavo. Post-paid, \$3.00.

Frank Forester's American Game in its SEASONS, Fully Illustrated and Described. New edition, post-paid, \$3.00.

The Dog.

By Diuks, Mayhew & Hutchison. Compiled and edited by Frank Forester. Containing full instructions in all that relates to the Breeding, Rearing, Breaking, Kenneling, and Conditioning of Dogs, with valuable recipes for the treatment of all diseases. Illustrated. Post octavo. Post-paid, \$3.00.

The Dead Shot:

Or, Sportsman's Complete Guide; a Treatise on the use of the Gun, with Rudimentary and Finishing Lessons in the Art of Shooting Game of all kinds. By Marksman. Post-paid, \$1.75.

The Crack Shot:

Or, Young Rifleman's Complete Guide; being a Treatise on the use of the Rifle, with Lessons, including a full description of the latest improved breech-loading weapons; rules and regulations for Target Practice, and directions for Hunting Game. By Edward C. Barber. Post-paid, \$1.75.

Gun, Rod, and Saddle.

Nearly fifty practical articles on subjects connected with Fishing, Shooting, Racing, Trotting, etc. Post-paid, \$1.

Practical Trout Culture.

By J. H. Slack, M. D., Commissioner of Fisheries, New Jersey. Fully illustrated and describing thoroughly all that is requisite to successful Trout Culture. Post-paid, \$1.50.

AGRICULTURE.

Woodward's Graperies and Horticultural BUILDINGS. Plans and Plans of Hot-beds, Cold Pits, Propagating Houses, Forcing Houses, Hot and Cold Graperies, Greenhouses, Conservatories, Orchard Houses, etc., with the various modes of Ventilating and Heating. Post-paid, \$1.50.

Jacques' Manual of the Garden, Farm, AND BAIN-YARD. Embracing the Cultivation of Vegetables, Fruit, Flowers, all Field Crops, Details of Farm Work and Rearing Domestic Animals. New and Revised Edition. One volume. Post-paid, \$1.75.

Young Farmer's Manual.

Vol. I. The Farm and the Workshop, with Practical Directions for laying out a Farm, Erecting Buildings, Fences, Farm Gates, Selecting good Farm and Shop Tools, and performing Farm Operations. Fully Illustrated. Post-paid, \$1.75.

Young Farmer's Manual.

Vol. II. How to Make Farming Pay, with full Details of Farm Management, Character of Soils, Flowing, Management of Grass Lands, Manures, Farm Implements, Stock, Drainage, Planting, Harvesting, etc. Illustrated. Post-paid, \$1.75.

Husmann's Grapes and Wine.

The Cultivation of the Native Grape and Manufacture of American Wine. By Geo. Husmann, of Missouri. Post-paid, \$1.50.

Elliott's Lawn and Shade Trees.

For Planting Parks, Gardens, Cemeteries, Private Grounds, and Avenues. Fully Illustrated and described. Post-paid, \$1.50.

Fuller's Forest Tree Culturist.

The Cultivation of Forest Trees for Shade, for Shelter, for Fuel, for Timber, and for Profit. Illustrated. Post-paid, \$1.50.

ORANGE JUDD COMPANY, 245 Broadway, N. Y.

GREAT DEDUCTION. TEA and COFFEES

At Wholesale Prices.
Increased Facilities to Club Organizers.
Send for New Price-List.

THE GREAT AMERICAN TEA COMPANY,
(P. O. Box 5643.) 31 and 33 Vesey St., New York.

WOOD, TABER & MORSE,
Eaton, Madison Co., N. Y.

MANUFACTURERS OF

Steam-Engines, Portable, Stationary, and Agricultural.

Hundreds in use in Shops, Print-
ing Looms, Mills, Mines, and on
Farms and Plantations for Grain
Threshing, Food Cooking for
Stock, Cotton Ginning, Sawing, etc.
Circulars sent on application.

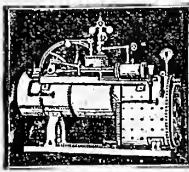

HOME

INSURANCE COMP'Y OF NEW YORK,
OFFICE, NO. 135 BROADWAY.

Cash Capital - - - \$2,500,000.00
Assets, Jan. 1, 1874 - 4,852,697.65
Liabilities - - - - 216,690.24

CHAS. J. MARTIN, President.
J. H. WASHBURN, Secretary.



LOVEJOY'S METALLIC WEATHER HOUSES

Indicate the changes in the weather, and
are pretty mantle ornaments. The little
lady appears in fair and the man in
stormy weather, and they never make
mistakes. Sent prepaid to any address,
safely packed, upon receipt of \$2 (two),
by ALVAN I. LOVEJOY,
Proprietor and Manufacturer,
229 Washington St., Boston.

Special price to dealers.

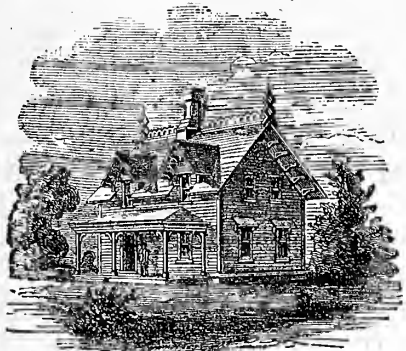

JUST PUBLISHED.

HUSSEY'S NATIONAL COTTAGE ARCHITECTURE;

OR,

HOMES FOR EVERY ONE.

With Designs, Plans, Details, Specifications, and Cost; with
Working Scale, Drawings complete, so that Houses may
be built direct from the book. Adapted to the popular
demand for practical, handsome, and economical homes.
Royal Quarto. Six Dollars, post-paid.

ORANGE JUDD COMPANY, Publishers,
245 BROADWAY, NEW YORK.

MONEY IN THE GARDEN.

A VEGETABLE MANUAL,

PREPARED WITH A VIEW TO

ECONOMY AND PROFIT,

BY P. T. QUINN,

PRACTICAL HORTICULTURIST.

In this work the author aims to give, in a plain, practical
style, instructions on three distinct although closely con-
nected branches of gardening—the kitchen-garden, market-
garden, and field culture; the only and sufficient credentials
for the fitness of his undertaking being a successful practical
experience for a term of years.

CONTENTS.

Chapter I. Money in the Garden.	Chapter VIII. Melons.
" II. Hot-beds.	" IX. Onions.
" III. Artichoke.	" X. Parsley.
" IV. Beans.	" XI. Radishes.
" V. Cabbages.	" XII. Salsify.
" VI. Egg-Plants.	" XIII. Tomatoes.
" VII. Lettuce.	" XIV. Forcing Houses.
Chapter XV. List of Seeds.	

PRICE, POST-PAID - - - - - \$1.50

ORANGE JUDD COMPANY,
245 BROADWAY, NEW YORK.

THE

Carpenters' & Builders' Guide;

BEING A

HAND-BOOK FOR WORKMEN,

ALSO

A Manual of Reference for Contractors,
Builders, etc.

By P. W. PLUMMER.

Fourth Edition. Four Plates, 72 pp. Price Post-paid, \$1.

Treats of Building Materials, Problems for Drafting,
Hand-Railing, Tables of Timber-Measure, Form of Builders'
Contract, Glossary of Terms.

HOYT, FOGG & BREED, Publishers, Portland, Me.
ORANGE JUDD COMPANY, New York.

FOREST TREES

FOR

Shelter, Ornament, and Profit.

BY ARTHUR BRYANT, SEN.,

President Illinois State Horticultural Society, 1871.

Contents:

Chap. 1. Introduction.
" 2. Evils attending the Destruction of the Forests.
" 3. Favorable Influences of the Forest.
" 4. Influence of Wood upon Moisture and Rain Fall.
" 5. Change of Climate in the Prairic Region.
" 6. Practicability of Raising Timber.
" 7. Propagation and Planting of Forest Trees.
" 8. Pruning and Thinning.
" 9. Exclusion of Animals from Woodlands.
" 10. Screens for Shelter.
" 11. Profit of Timber Culture.
" 12. Description of Individual Deciduous Trees.
" 13. Coniferous Trees.
" 14. Propagation of Conifers from Seed.
" 15. Transplantation of Conifers.
" 16. Description of Individual Coniferous Trees.
" 17. Broad-leaved Evergreens not Coniferous.

The Descriptive List of Trees and Evergreens is believed to
be the most full and accurate yet written for Amer-
ican use.

Finely Illustrated with 12 Full-Page Engravings.

PRICE, POST-PAID..... \$1.50.

Address

ORANGE JUDD COMPANY,
245 BROADWAY, NEW YORK.

Farm - Gardening

AND

SEED - GROWING.

BY FRANCIS BRILL.

NOTICES BY THE PRESS.

Orange Judd & Co. have added to their splendid catalogue
of agricultural books "Farm-Gardening and Seed-Grow-
ing," by Francis Brill; it is practical, plain, complete, and
satisfactory, so that for a small amount of money a great
deal of desirable information can be obtained. If there is
any firm anywhere which is to-day disseminating so much
knowledge in regard to tilling of the soil as this same said
firm of Orange Judd & Co., we will present a medal to our
informers.—*Watchman and Reflector* (Boston).

The want occasionally expressed to us of a work on the
cognate subjects above named (Farm-Gardening and Seed-
Growing), is now met in a book under this title from the
pen of Mr. Francis Brill, formerly a market-gardener and
seed-grower at Newark, N. J., and at present engaged in
raising seeds at Mattituck, L. I. Its directions are concise
and practical, covering those points on which a beginner is
most likely to require information.—*Country Gentleman*.

Mr. Brill has had large experience, and derived his knowl-
edge wholly from the school of actual tests.—*Chicago
Evening Journal*.

We have in this volume the results of a practical man's
experience in raising root crops and other vegetables in the
market-garden. Not only the professional seed-grower and
trucker, but the amateur gardener who has a little patch in
his suburban home, will find many a valuable hint and di-
rection in this full and comprehensive manual.—*Sunday-
School Times*.

It seems to be a very sensible, practical work by a practi-
cal man. Mr. Brill's father was a gardener; and he himself
has had an extensive experience, and he talks about what
he knows, which is more than can be said of many authors of
industrial works.—*Moore's Rural New Yorker*.

There can be no question that this farm-gardening can be
made in many districts of the Southern Atlantic States, es-
pecially near the coast, far more profitable than growing the
ordinary staple crops. In connection with producing the
vegetables, the growing and saving their seeds receive
minute attention.—*American Farmer* (Baltimore).

This industry is now occupying the attention of many per-
sons who sell their products to the great seed-houses, and
novices who have the facilities, and wish to enter upon the
business, will find in this book just the hints needed.—
Springfield Republican.

Mr. Brill has been a successful farm-gardener and seed-
grower for a number of years, and gives in a clear and con-
cise form the knowledge he has gained. . . . It gives the
best method of manuring, planting, and cultivating every
vegetable sold in markets—in short, everything required to
be known, plainly and fully—and should be in the hands of
every one who cultivates so much as a rod of land, for
family use, pleasure, or profit.—*Suffolk* (L. I.) *Times*.

The seal of Orange Judd & Co. upon an agricultural pub-
lication is sufficient guarantee of its worth. Francis Brill's
book, published by them, is a very complete work, giving
plain, minute instructions as to raising, taking care of, and
bringing to market those vegetables which are most in de-
mand in the large cities, and those seeds which are being
called for throughout the country.—*N. Y. Evening Mail*.

The work of showing how this can be accomplished has
fallen in good hands, and it has been done well. The book
will well repay perusal, and we hope soon to see its good
effects in a more intelligent direction of farm industry, and
accompanied by more satisfactory pecuniary results.—*The
Signal* (L. I.)

To the market-gardener, or even the owner of a small
piece of tillable land, this book will be of great value.
Qualities of soil required for the growth of different vegeta-
bles, how to plant, how to cultivate, to harvest and preserve
during winter.—*N. Y. Citizen and Round Table*.

Price, Post-paid, \$1.00.

ORANGE JUDD COMPANY,
245 BROADWAY, NEW YORK.

WANTED.—The United States Life Insurance Company is now reorganizing its Agency
Department, and is prepared to negotiate with gentlemen of business ability to act as
Agents. Previous connection with the business is not considered necessary.
Apply at the Home Office, 261 Broadway, New York. JOHN E. DEWITT, President.

NOW READY.

OUR NEW CHROMO,

ENTITLED

"Up for Repairs,"

A

Beautiful, New Picture

For Every Subscriber

TO THE

American Agriculturist

FOR 1874.

The great satisfaction which has been expressed by tens of thousands of subscribers to this paper who have received the picture entitled "Mischief Brewing," has led the Publishers to provide another beautiful Gift for their patrons for the coming year.

An exquisite Oil Painting by the celebrated American Painter, Mr. B. F. Reinhart, executed expressly for the *American Agriculturist* and entitled

"UP FOR REPAIRS,"

has been most successfully reproduced in Chromo by the well-known firm of Beneke & Seott. It is a picture of a scene in childhood, which many will recognize as what they have themselves witnessed or been actors in, and can not fail to please both old and young. The Chromo is so perfectly done as scarcely to be distinguished from the original.

The Publishers will give this beautiful Chromo

To Every Subscriber

to this paper for the year 1874 received after this date, as detailed below. It is ready for immediate delivery at 245 Broadway, Free of Charge.

If to go by mail, 10 cents must be sent to cover cost of packing and postage. **For 25 cents it will be Mounted, Varnished, Packed, and sent Post-paid.**

N. B.—The Chromo will be delivered:

At the Office, **Unmounted**, Free.

“ “ “ **Mounted**, 15 cents extra.

Sent by Mail, **Unmounted**, 10 cents extra.

“ “ “ **Mounted**, 25 cents extra.

We advise all to have them mounted before leaving the office, as in the large quantities we put up we are able to mount them for a quarter of the cost of doing it singly, and better than it can usually be done elsewhere.

The picture is designed for every subscriber upon the terms stated above, which please read carefully; and on these terms all are alike entitled to it, whether their names come singly at \$1.50 each, or in Clubs of Four for \$5, or Clubs of Ten at \$1.20 each, or in Clubs of Twenty or more at \$1 each. Subscribers in Premium Clubs will also thus be entitled to it.

N. B.—A few of the beautiful pictures entitled "MISCHIEF BREWING," which have been given to so large a number of subscribers, are still in stock, and, while any remain, subscribers to the *American Agriculturist* can have their choice between this and the new Chromo "UP FOR REPAIRS;" but the choice must be named at time of subscribing.

Subscribe Now.

ORANGE JUDD COMPANY,

245 BROADWAY, NEW YORK.

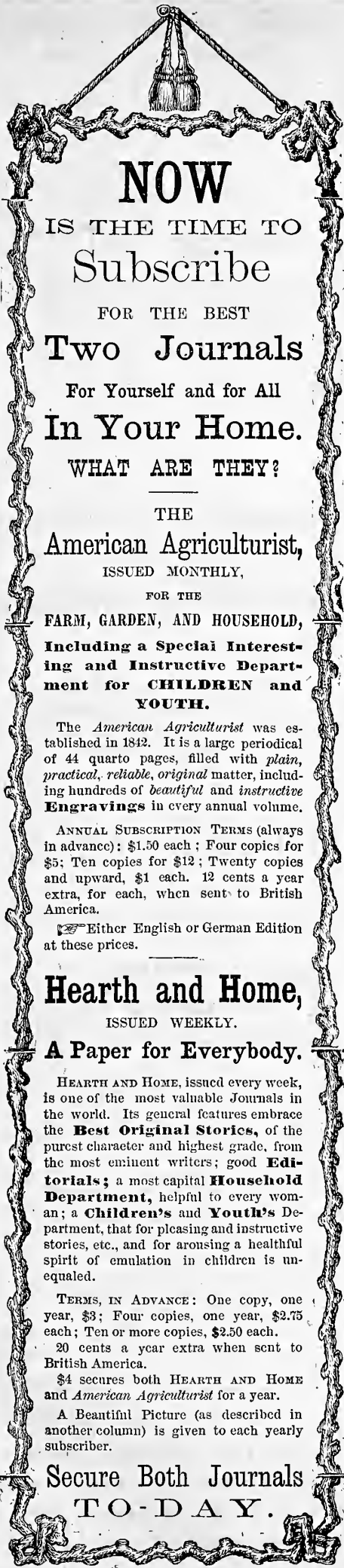

NOW

IS THE TIME TO

Subscribe

FOR THE BEST

Two Journals

For Yourself and for All

In Your Home.

WHAT ARE THEY?

THE

American Agriculturist,

ISSUED MONTHLY,

FOR THE

FARM, GARDEN, AND HOUSEHOLD,

Including a Special Interesting and Instructive Department for CHILDREN and YOUTH.

The *American Agriculturist* was established in 1842. It is a large periodical of 44 quarto pages, filled with plain, practical, reliable, original matter, including hundreds of beautiful and instructive Engravings in every annual volume.

ANNUAL SUBSCRIPTION TERMS (always in advance): \$1.50 each; Four copies for \$5; Ten copies for \$12; Twenty copies and upward, \$1 each. 12 cents a year extra, for each, when sent to British America.

Either English or German Edition at these prices.

Hearth and Home,

ISSUED WEEKLY.

A Paper for Everybody.

HEARTH AND HOME, issued every week, is one of the most valuable Journals in the world. Its general features embrace the **Best Original Stories**, of the purest character and highest grade, from the most eminent writers; good **Editorials**; a most capital **Household Department**, helpful to every woman; a **Children's and Youth's Department**, that for pleasing and instructive stories, etc., and for arousing a healthful spirit of emulation in children is unequalled.

TERMS, IN ADVANCE: One copy, one year, \$3; Four copies, one year, \$2.75 each; Ten or more copies, \$2.50 each.

20 cents a year extra when sent to British America.

\$4 secures both HEARTH AND HOME and *American Agriculturist* for a year.

A Beautiful Picture (as described in another column) is given to each yearly subscriber.

Secure Both Journals TO-DAY.

NOW READY.

OUR NEW CHROMO

ENTITLED

"Look Out!"

A

BEAUTIFUL, NEW PICTURE

For Every Subscriber

TO

Hearth AND Home

FOR 1874.

Another fine Oil Painting has been executed by Mr. Reinhart for the Publishers of HEARTH AND HOME. It has also been reproduced with great success in Chromo. This Picture, which is entitled "LOOK OUT!" is finely colored, and the same in size as the Chromo "Up for Repairs," which has been executed for subscribers to the *American Agriculturist*. It is designed as a Present for ALL Subscribers to HEARTH AND HOME for the year 1874, received after this date, including single subscribers, those in Clubs, etc.

It will be delivered at 245 Broadway free of charge. If to be sent by mail, 10 cents must be furnished to prepay packing and postage. **For 25 cents it will be Mounted, Varnished, Packed, and sent Prepaid to subscribers to HEARTH AND HOME for 1874.**

N. B.—The Chromo will be delivered:

At the office, **Unmounted**,.....Free.

“ “ “ **Mounted**,.....15 cts. extra.

If sent postpaid, **Unmounted**,...10 cts. extra.

“ “ “ **Mounted**,.....25 cts. extra.

A few of the beautiful pictures, "The Strawberry Girl," which have been given to thousands of subscribers, are still in stock, and, while any remain, subscribers to HEARTH AND HOME can have their choice between this and the new Chromo, "Look Out!"; but the choice must be named at time of subscribing, and if the first is taken, **50 cts.** extra, instead of 25 cts., must be sent for mounting, packing, and prepayment.

The price of HEARTH AND HOME is \$3 a year, or \$4 secures HEARTH AND HOME and *American Agriculturist*.

\$3.25 will pay for HEARTH AND HOME and New Chromo mounted, and Chromo will be packed and sent, prepaid, to the subscriber. (\$3.50 if Chromo "Strawberry Girl" is taken instead of "Look Out!")

\$1.75 will pay for *American Agriculturist* and Chromo, mounted, and Chromo will be packed and sent, prepaid, to the subscriber.

\$4.50 will pay for *American Agriculturist* and HEARTH AND HOME together, with both Chromos, mounted, and Chromos will be sent, prepaid, to subscriber. (\$4.75 if Chromo "Strawberry Girl" is taken.)

SUBSCRIBE NOW.

Secure Both Papers. Secure Both Pictures. Get your Neighbors to Join you. Do good, Be wise, and Be happy!

ORANGE JUDD COMPANY, Publishers,

245 BROADWAY, NEW YORK.

MARCH, 1874.

AMERICAN

AGRICULTURIST

FOR THE FARM, GARDEN & HOUSEHOLD.



Vol. XXXIII

Number 3

PUBLISHED BY THE
ORANGE JUDD COMPANY,
245 BROADWAY,
NEW-YORK.

BOOKS FOR FARMERS AND OTHERS.

[Published and for sale by the Orange Judd Company, 245 Broadway, New York. Any of these books will be forwarded by mail, post-paid, on receipt of price.]

Table listing various books for farmers and others, including titles like 'Allen's (L. F.) American Cattle', 'Woodward's Suburban and Country Houses', and 'Hussey's National Cottage Architecture'.

Table listing various books for farmers and others, including titles like 'Woodward's Suburban and Country Houses', 'Woodward's Country Homes', and 'Hussey's National Cottage Architecture'.

FOR FRUIT, ORNAMENT. TREES FOR PLEASURE, PROFIT.

And PLANTS from an Old and Reliable Nursery. Pears, Grapes, Apples, Cherries, Peaches, Quinces, Plums, Berries. EVERGREENS & DECIDUOUS TREES. Variegated-Leaved and Flowering Shrubs, Clematis Jackmanii and other Climbing Vines. ROSES—Moss, Tea, and Perpetual.

FRUIT KNOX SERIES FRUIT FARM & NURSERIES FRUITS AND FLOWERS FOR 1874. Send stamp for Catalogue of Vines, Plants, Trees, etc. GRIMES & MEYER, Box 115, Pittsburgh, Pa.

THE CROTON GRAPE. Fine two-year-old plants of this variety by mail or express. Send for price-list. S. W. UNDERHILL, Croton Landing P. O., N. Y.

Traveler's Broom-Corn Cultivator and Broom-Makers' Manual. Price 50c. Tenn. Evergreen Broom-Corn Seed, dead ripe, \$3.50 per bush; less quantity, \$1.00 per peck. Charleston, Coles Co., Ill. R. A. TRAVELER.

To Inventors. Full information in regard to obtaining Patents sent free. Address G. W. RICHARDS, No. 6 Federal Buildings, Washington, D. C. Box 642.

INVENTORS Who wish to secure PATENTS should write to MUNN & CO., 37 Park Row, New York, for Advice and Pamphlet, 103 pages, FREE.

THE GENUINE EXCELLENCE and priceless value of the new method of curing Rupture with certainty and without inconvenience to the sufferer is well illustrated by the following letter, the original of which may be seen at the New York business office of the Blade, Bates & Locke, corner of Park Row and Beekman st. 'To the Editor of the Toledo Blade: About ten months ago I saw in your paper an advertisement of the Elastic Truss, directing to send for circulars to the Elastic Truss Co., No. 683 Broadway, N. Y. City. I was at that time laboring under pain and all the inconvenience of rupture. I sent as directed and obtained a circular, and also, by measurement and directions, I obtained the Truss and applied it. I have worn it about nine months, and I am happy to say to you to-day that, though I am seventy-four years of age, I consider myself cured, and all without pain or inconvenience. I still wear the Truss as a matter of choice; it seems like a part of my clothing. I would say to every one afflicted with Hernia: Try it—it will cure. I want to say to you that the knowledge I obtained through that advertisement has been worth more to me than the subscription of the Blade for twenty years; and I believe it to be the duty of every newspaper in the land, from the Congressional Globe to the smallest village paper, to publish it for the good and benefit of suffering humanity. Yours truly, C. P. LANPHELE.' This new Truss is sold cheap, and sent by mail, and circulars sent free, by the Elastic Truss Co., No. 683 Broadway, New York City.

Sexual Physiology. By R. T. TRALL, M. D. Containing Sexual Generation; the Physiology of Menstruation; Impregnation; Pregnancy; Parturition; Lactation; the Law of Sex; Regulating the Number of Offspring; the Law of Sexual Intercourse; Hereditary Transmission; Philosophy of Marriage. Prof. Wilder, of Cornell University, says it is the best work yet written on the subject. 20,000 sold. Price \$2.00 by mail. For \$3.50 we send this book, The Herald of Health for one year, and a volume of the Complete Works of Shakespeare, containing 1,000 pages and 36 Illustrations. Agents wanted. WOOD & HOLBROOK, 15 Light St., New York.

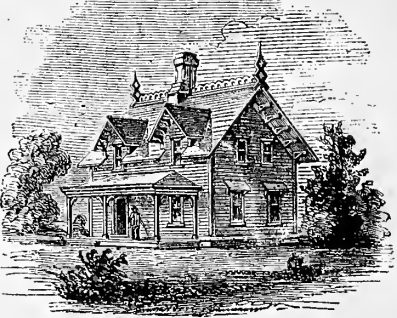

HUSSEY'S NATIONAL COTTAGE ARCHITECTURE; OR, HOMES FOR EVERY ONE. With Designs, Plans, Details, Specifications, and Cost; with Working Scale, Drawings complete, so that Houses may be built direct from the book. Adapted to the popular demand for practical, handsome, and economical homes. Royal Quarto. Six Dollars, post-paid. ORANGE JUDD COMPANY, Publishers, 245 BROADWAY, NEW YORK.

WANTED.—The United States Life Insurance Company is now reorganizing its Agency Department, and is prepared to negotiate with gentlemen of business ability to act as Agents. Previous connection with the business is not considered necessary. Apply at the Home Office, 261 Broadway, New York. JOHN E. DEWITT, President.

AMERICAN AGRICULTURIST

FOR THE

Farm, Garden, and Household.

"AGRICULTURE IS THE MOST HEALTHFUL, MOST USEFUL, AND MOST NOBLE EMPLOYMENT OF MAN."—WASHINGTON.

ORANGE JUDD COMPANY,
PUBLISHERS AND PROPRIETORS.
Office, 245 BROADWAY.

ESTABLISHED IN 1842.

Published also in German at \$1.50 a Year.

{ \$1.50 PER ANNUM, IN ADVANCE.
SINGLE NUMBER, 15 CENTS.
4 Copies for \$5; 10 for \$12; 20 or more, \$1 each.

Entered according to Act of Congress, in February, 1874, by the ORANGE JUDD COMPANY, at the Office of the Librarian of Congress, at Washington.

VOLUME XXXIII.—No. 3.

NEW YORK, MARCH, 1874.

NEW SERIES—No. 326.

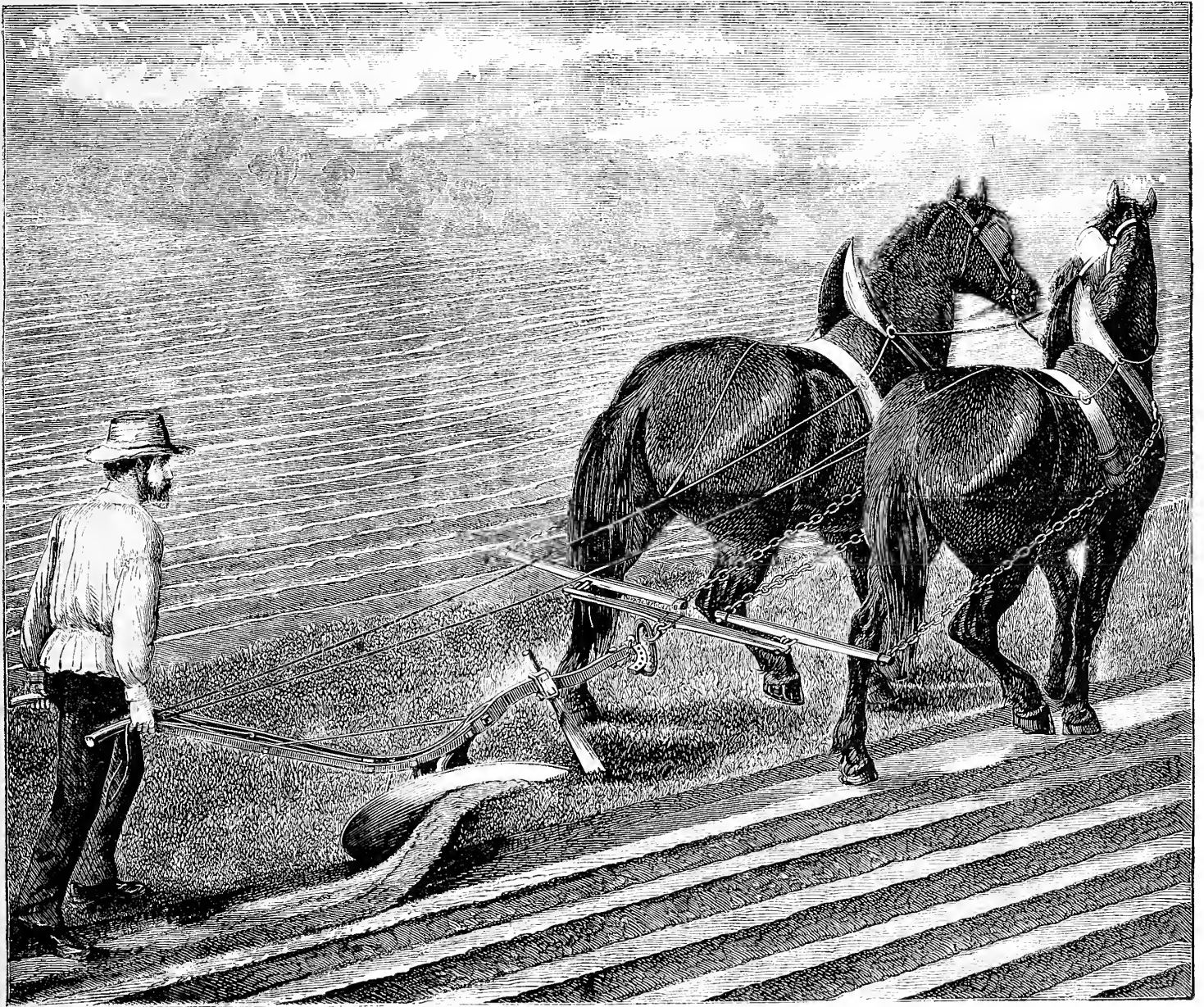

PLOWING SOD. — Drawn and Engraved for the American Agriculturist.

The manurial value of a sod plowed beneath the surface very much depends upon the manner in which it is turned under. If the furrow is turned in a continuous strip unbroken and made to lap upon the preceding furrow, as it appears in the above engraving, the utmost value of the sod is secured. For it is only as it becomes decomposed and furnishes food for the succeeding crop that it is of any value. If the furrow is irregularly turned and broken into fragments a large portion of the sod is unburied; it simply dries upon the surface and remains useless. Besides a furrow so turned furnishes a poor seed-bed because it is not compact and solid. On the contrary, a properly

turned sod forms an excellent seed-bed. The surface of the field when plowed forms a succession of ridges of soil exactly parallel with each other. When these ridges are harrowed down the sod beneath is not torn up, but is evenly covered with a fine layer of soil just sufficient in depth to form a seed-bed, beneath which there is stored every particle of the sod in the best condition to furnish food for the young plants, the roots of which penetrate the soil exactly where their food lies. This is apparent when the position of the furrow slices, as above shown, is observed.

Unfortunately we possess few plows that are capable of turning such a furrow as is here

described. The mold-boards of our plows are in general too short to turn a perfectly unbroken furrow. The better farming of our neighbors, the Canadians, and the English farmers, is to some extent due to the extreme care with which they plow, especially sod land. With us the yield of corn depends greatly upon the manner in which the sod is plowed, and the kind of plow we use becomes a very important consideration. The plow shown in the engraving is an iron beam English one, of the Scotch pattern, having a share about four feet long. Its great length enables it to turn the furrows with perfect regularity, leaving the soil in the best condition.

Contents for March, 1874.

Bar, Plan for a Commodious... 6 Illustrations... 97
Bee Notes for March... 90
Breeding, In and In... 99
Boys and Girls' Columns—The Doctor Takes the Boys to a Match Factory—Aunt Sue's Puzzle-Box—Bears, Performing—Steamboat, First—Ladder, Carrying a... 6 Illustrations... 107, 108
Bucket for Water Wheels... 2 Illustrations... 96
Butter and Cheese Dairying... 99
Calves, Black Leg in... 97
Cattle Tle, a Safe... Illustrated... 98
Catalogues... 83
Cow, Ayrshire... Illustrated... 93
Dairy, Butter... 4 Illustrations... 96
Fence for Poultry Yard, Portable... 3 Illustrations... 97
Fern, Climbing... Illustrated... 104
Flouring Mill... 4 Illustrations... 100
Flower Garden and Lawn for March... 84
Fruit Garden for March... 83
Grass, Mixed... 99
Grass, Permanent... 99
Greenhouse and Window Plants for March... 84
Hogs, Salt for... 99
Household Department—Wall Pockets and Holders—Sweet Home—What Shall we have for Breakfast?—Medical Matters, Concerning—Minor Hints and Notes—Netherland Breakfast—Johnny Cake with Eggs—Paradise Cake... 2 Illustrations... 105, 106
Kitchen Garden for March... 98
Little Farm well Tilled... 98
Maunre, Making Rich... 95
Market Report for March... 84
Notes from the Pines... 102, 103
Ogden Farm Papers, No. 49—Butter Statistics... 90, 91
Orchard and Nursery for March... 83
Patents... 89
Plant, Butterfly Weed... Illustrated... 101
Plant, Burnet Canada... Illustrated... 104
Plant, Carolina Jessamine, Double... Illustrated... 101
Plants, Packing Living... 102
Pony, Shetland... Illustrated... 93
Potatoes, Two New... 2 Illustrations... 92
Punch for a Bull's Nose... Illustrated... 99
Pupils Farmers... 98
Robin, New Trick of the... 103
Salt for Stock, Use of... 95
Shrub, Olive Fragrant... Illustrated... 101
Skill, Value of... 99
Sod Plowing... Illustrated... 81
Sweet-Potato Plants, Hardened... 89
Tomato Plants, Raising... 103
Tree, Blue Gum... 92
Traps from Seed, Forest... 89
Walks and Talks on the Farm, No. 193... 94, 95
Whipple-Trees, Three-Horse... Illustrated... 99
Work, Hints About... 82

INDEX TO "BASKET," OR SHORTER ARTICLES
Animal Dust... 87
Architecture, Hussey's National Cottage... 86
Bantams, Seabright... 86
Barrow, Feed... 87
Blue-Grass Region of Kentucky... 87
Botanical Directory... 86
Camellias... 87
Camellia with two Centers... 85
Chervil, Tuberos... 87
Cornell University... 87
Corn, Triumph Sweet... 85
Cranberries... 87
Cream, Foaming... 87
Crops for Sowing to Grass... 87
Cucumbers, Manure for... 87
Dairyman's Assoc., Ohio... 86
Dollars and Greenbacks... 87
Farmer, Becoming a... 87
Fish, Gold... 87
Fisk & Hatch, Banking House of... 86
Geraniums, Double... 87
Hay Press, Improved... 86
Hedge... 87
Hens, Web-Footed... 87
Hickory, Grafting the... 85
Hooks or Haws... 87
Horse-Shoeing, Rational... 87
Horticulture, Pupils in... 86
Horticulturist, Death of a... 87
Humbugs, Sundry... 85
Malt Diet... 87
Manure, Fresh or Decomposed... 87
Manure, Saving... 87
Mower, a Guinea... 87
Mr. Judd's Health... 85
Mucilage... 87
Peach, Early Beatrice... 87
Pear Trees... 87
Peas, Bugs in... 87
Roses by Mail... 86
Senate, Now for the... 85
Spruce, Norway... 87
Thrashing Machine, New... 86
Walks in a Lawn... 85
Whitewash, Permanent... 87
Willows... 87
Windmill, What Came of a... 87

Desirable Wood-Lands.—"A Young Farmer," Elmira, N. Y. There is a large tract of very desirable forest lands still unoccupied in Michigan. These lands are now made accessible by several railroads. The Grand Rapids and Indiana Railroad has opened a fine country near Grand Traverse Bay, covered with beech and maple timber, which always denotes the best wheat lands. The Flint and Pere Marquette road and the Jackson, Lansing and Saginaw road have also opened fine tracts of farming and lumbering lands. For those who desire to locate upon timber lands, these are very attractive, having the same climate as that of Western Canada and being equally fertile. In addition to their agricultural value, the timber upon these lands, in most cases, will more than pay for clearing them, and leave the land free of cost. A large quantity of these lands are for sale by the above roads at moderate prices.

Sugar-Making Machinery.—"Sugar Maker." The sugar-making machinery made by Geo. L. Squier & Bro., of Buffalo, is adapted to the use of either the smallest or the largest planter. For making maple sugar or syrup from sorghum, their "American Evaporator" with portable furnace will be found very suitable. They also make a very strong horse-power, called the Sampson, for the purpose of driving the mills for crushing cane or for other purposes. Their machinery has taken first premiums wherever it has been exhibited, from Louisiana to New York.

Calendar for March.

Table with columns for Day of Month, Day of Week, and sunrise/sunset times for Boston, N.Y., Philadelphia, and Washington.

PHASES OF THE MOON.

Table showing moon phases (Full, 3d, New, 1st) for Boston, N.Y., Wash'n, Phila'ston, and Chicago.

AMERICAN AGRICULTURIST.

NEW YORK, MARCH, 1874.

Said a large iron manufacturer to us a few days ago: "I have been visiting some of the principal factories, in company with our foreman, to see what new and improved processes are adopted. We have picked up many ideas that will be of great use to us. Time was when we could get high prices for our products, but now the manufacturer must study the closest economy. Our profits come from what we can save by adopting the best processes."

This seemed to be a new idea to him. "Farmers," we remarked, "have always had to practice the closest economy. There is no business in which there is so much competition. We have long known that we must look to our profits by cheapening production."

We fear, however, that we elaimed more for farmers than we are justly entitled to. Farmers are personally economical. As a rule, they do not spend too much on themselves or their families. But are we truly economical in our farm management? Do we spend our time and labor to the best advantage? Are we getting full returns from our horses, cows, sheep, and pigs? They are eating every day, and cost us a large sum in the aggregate for food and attendance. If we take a load to market and come back empty we are losing half our own time and nearly half the powers of the team. If we set a man to plow, harrow, or cultivate with one horse when the work requires two, we are losing half the man's wages. If he uses two horses when three are required we lose one-third of his labor. It is a good time to think about these things, and make preparation for performing our work with the least loss. We hope no reader of the Agriculturist will let the present month of comparative leisure go by without doing everything that can be done to facilitate the labors which will press upon us in a few weeks.

Hints about Work.

Hire Men for the Season.—Wages will be lower. But if you can find a good man pay him what he is worth. Let him feel that it is getting good pay for good work. Cottages for farm laborers are much needed; they save much labor in the farmer's house.

The Farmer should Own the Cottage, and let the rent apply on the wages. If you rent the cottage you have no hold on the man. But if you let him have the house as part of the wages you can turn him out for disobedience or for any reason sufficient to legally justify you in discharging a hired man.

A Married Man should, however, be treated with great forbearance. It is a cruel thing to turn a family out of doors. If the man is getting careless, let him know that you have this power, but do not exercise it except in extreme cases.

Day Men can usually be obtained early in the spring at comparatively low wages. We had men willing to work on our own farm in March for half what the same men ask in May, June, and July.

The Days are Getting Longer.—We do a great deal of work in October and November, and pay very high wages. But the day is longer in February (say 10.40) than it is in November (say 9.55), and longer in March (say 12.17) than in October (say 11.07); in fact, nearly as long as in September (say 12.28). If we have any work that can be conveniently done, therefore, we can not only get men at low wages, but the night does not come so soon as in October.

Write Down everything you have to do during the next four or five months; and then see if there is not something that you can do now that will save time and labor.

If you are going to Build, cut and hew the timbers and draw them where they are wanted. Draw the lumber while there is sleighing.

Keep the Teams at Work.—Better hire an extra man than let the horses lie idle.

Draw Wood, and saw and split and pile up in the wood-house all you will want until next winter.

Green Cord-wood should be drawn and put in a pile to season. Do not let it remain in the woods, and then have to draw it in the summer when you should be doing more important work.

Draw Plaster, and sow it direct from the sleigh or wagon or stow it away in a dry place. It will not injure by keeping, unless it gets damp and lumpy.

Draw Manure to the field where needed and put it in a pile to ferment. If some portions of the manure are wet and some dry mix them together in the new pile.

Cut up Hay and other Fodder with a horse-power machine and stow it away for future use. Scatter a little salt on it, say at the rate of two quarts to a ton.

Damaged Hay should be cut up and steamed. Molded hay is very injurious unless steamed or moistened with boiling water to destroy the fungus.

A Good Grindstone is a necessity on every farm. If you have a horse-power or a wind-mill it will pay well to attach a driving-wheel to your grindstone. You can then grind coulters, cultivator teeth, axes, spades, hoes, hay-knives, scythes, cradles, corn-cutters, cold-chisels, and anything and everything you will be likely to want during the coming busy season.

Put everything in perfect repair.—See Hints for last month. If you are near a blacksmith and wheelwright's shop you can probably get the work done cheaper and better than by doing it yourself. But when you have to send several miles there are many little things that can be repaired at home in less time than is required to take them to the shop.

A Chest of Tools and a Tool Shop will pay for themselves every year, provided you keep the tools in good order and in their proper places. This is the age of machinery, and every farmer should be more or less of a mechanic.

Clean Out Stables and Barns and leave no cobwebs. If you are a slovenly man and do not know how to "tidy up," get your wife to show you how.

Push things the coming season. Times will be better. Produce will be higher. Raise all you can and get ready for the work now. Be hopeful, energetic, systematic, and industrious, and you will find farming pleasant and profitable.

Keep Out of Debt.—It is better to work for some one else than to pay 12 or 15 per cent for money.

Animals need special care this month. The weather is often changeable. We have sometimes a rain-storm that will drench even a sheep to the skin. Nothing can be more injurious to sheep unless it is a close, damp, dirty basement stable.

Sheep will stand severe cold, but they should always have shelter from winds and rain. If they must be exposed to storms feed more grain.

Ewes in Lamb should have as much exercise as they can be induced to take. Be careful that they do not crowd each other in going through doors or gates. Do not feed musty hay. A moderate allowance of bran is desirable, but not enough to scour them. We find no ill effects from feeding large sheep one pound each of bran per day. If in high condition give no grain, but if thin or they are exposed to storms from a half to one pound each per day of oats or corn will be very beneficial.

Put Sheep are generally sold to good advantage this month.

Ewes Suckling Lambs should have the best of care and feed. Bran, mangel-wurzel, and clover hay will favor the production of milk. A little oat-meal, corn-meal, or bran stirred into the water they drink is excellent.

The Lambs if strong and healthy will begin to eat a little when two or three weeks old. Let them have a small trough with a little bran, or oil-cake, or oats, or sliced mangels separate from the ewes.

For Scours in young lambs we usually give a teaspoonful of castor-oil and from three to five drops of laudanum. Magnesia or prepared chalk is good. For mild cases in older lambs or sheep there is nothing better than milk porridge made with fresh milk and wheat flour. Make it as you would if for yourself and give from half a pint to a pint to each.

Cows in calf should have plenty of food and exercise. For three or four weeks before calving give sufficient flaxseed, bran, or oil-cake to keep the bowels moderately loose. If the cow is in high condition it is well to give from a half to one pound of Glauber's-salts once a week for a month previous to calving. Two table-spoonfuls of ginger is a desirable addition to the drench.

After Calving keep the cow in the stall for three or four days, give warm bran mash. Let the cow have all the water she will drink, but take the chill off of it. If the cow is in low condition and the placenta is not discharged give tonics such as oat or corn-meal gruel, bran mash, flaxseed tea, or a pint of warm ale. The placenta may be sometimes easily removed by taking it in the hands and gently twisting it as you would a rope. Keep twisting without pulling till it comes away.

Milking Clean is very important. It is sometimes a good plan to draw all the milk you can get and then let the calf remain with the cow for an hour or so. It will milk clean.

Horses that have been nearly idle all winter should now be worked moderately and fed better. Do not expose them to cold storms. Be careful to blanket them when they have to stand when heated. Clean thoroughly. See hints for last month.

Swine are now attracting renewed attention. The prospects for breeders and feeders are encouraging. This stock is worthy of better care than it usually receives.

Little Pigs will come by the million this month and the next, and as usually managed will die by the thousand.

The Sow for a week or so before the pigs are expected should be placed in a warm, dry pen by herself. Give light, sloppy food. If costive give her a pint of flaxseed boiled for two or three hours in half a pail of water. Give this once a day with bran till the bowels are loose. When pigs come in cold weather our own plan is to cover the sow with a horse blanket and keep the little ones at the teats under the blanket. We have saved many pigs by this simple plan. Feed the sow warm bran mash for a week with slops from the house, and afterwards give richer feed.

Work in the Horticultural Departments.

The winter up to the time of writing has been so mild that many out-of-door operations could be carried on, and all who were so fortunate as to take advantage of this weather, will find a great difference in their spring work. March is usually such a blustering month that there is not much pleasure in outside work, but every mild day should be turned to account if there is much still undone. Manure can be composted and earted out while the ground is hard at a less expense than later in the season. See that all the labor needed is provided for early, as the earlier a man is obtained in the spring the better is the chance of securing a useful one. Labor at this season is more abundant and cheaper than it will be later.

Orchard and Nursery.

Nurserymen will soon commence to send out stock, and all who have to procure their trees from a distance ought to send their orders at once. If delayed until the trees are wanted, the stock of many of the best varieties will often be exhausted. When the trees arrive unpack at once, and if the ground is not prepared for planting out, heel in in a dry spot until needed. When ready to plant the tops should be cut back at least one third, and the branches shortened, to compensate for the loss of roots in removing from the nursery. If any

Shrivelled Trees are found bury the whole tree in the ground for a few days, and the bark will usually assume its plump condition.

Girdled Trees should be treated as recommended last month.

Grafting.—Cherry and Plum trees should be grafted earlier than apple and pear trees.

Pruning.—Continue to prune while vegetation is dormant, taking care to cover all large cuts with melted grafting-wax, shellac varnish or paint. A good mixture for grafting-wax is with three parts beeswax, three parts rosin, and two parts tallow; melt and mix the whole well together.

Cions.—Cut as long as the sap continues dormant, and preserve as before directed.

Fruit Garden.

Most of the directions given under the orchard and nursery will apply here.

Raspberries.—Set as early as the ground will allow, in rows from four to six feet apart, according to the variety. If the old canes were not cut away in the fall, remove now, before the new growth commences.

Blackberries ought to be planted early, before they commence their growth, as they are liable to be injured if moved after they have started. Six feet apart is sufficient if all suckers are kept out, and the branches pinched back during growth.

Currants.—Make cuttings of such varieties as are wanted, and plant four inches asunder in rows two feet apart, taking care to press the earth firmly around the base of the cutting.

Grape-vines.—Plant as soon as the soil is in proper condition, using no manure. Cut back the canes to three eyes, only one of which should be allowed to grow. Plow old vineyards and apply a dressing of coarse ground bones. Posts for trellises may be set whenever the frost is well out.

Strawberries.—Plant out new beds and remove all runners not wanted for planting from the old beds. Set the plants in rows two feet apart, and eighteen inches in the rows. Mulch with leaves or cut straw to keep the newly-planted beds from drying out during the summer, and upon old beds to promote growth and keep the fruit clean. Use well-rotted manure before setting out plants.

Kitchen Garden.

It has been our custom to give the names of the standard varieties of vegetables in the March number of the *Agriculturist*. From this list, those who

are entirely unacquainted with the best sorts for general use, will be able to select varieties that have been well tested. They will find numerous other sorts in the catalogues.

Early Plants.—The simplest way of securing early plants, where but a few are required, is to start them in window-boxes. These ought to be three or four inches deep, and filled to within half an inch of the top with fine, light, rich garden soil. For raising plants largely, of course they must be sown in a hot-bed.

Cold Frames should be looked after carefully, and plenty of air given when the weather is mild, or else the plants will become drawn. Give water only when the soil appears dry.

Novelties.—Every year our seedsmen offer novelties in their catalogues. These are often no better than older kinds, but now and then one finds a treasure, and the trial of novelties is an interesting part of gardening to those who can afford time and money. Some of the most promising novelties of this year will be found on page 102 of this number.

Asparagus.—Old beds that were top-dressed last fall should have the litter raked off and the fine manure forked in between the plants. Set out new beds with one-year-old plants. The old way is to make the rows 18 inches apart, with the plants 9 inches apart in the rows. Our market growers give more room, setting the plants two feet or more apart each way. Set the plants four inches below the surface. Conover's Colossal is a reliable variety.

Beans must not be planted until all danger of frost is passed. Sow Early Valentine and Dwarf Wax for early bush in rows two feet apart. Giant Wax and Large Limas (when the season is long enough) are the best pole sorts for general use.

Beets may be sown as soon as the frost is out of the ground, as they will bear considerable cold after they have been planted. Sow thickly in hills one foot apart; the thinning can be used for greens. New Egyptian Blood is the best dark early sort, Bassano light colored but early; Long Blood late.

Broccoli.—Sow and treat the same as recommended for cabbages. White or Purple Cape.

Cabbage Plants wintered in a cold-frame may be set out as soon as the ground can be worked. Jersey Wakefield and Early York are best early; Early Winnigstadt medium; Drumhead, Flat Dutch, and Late Bergen should be sown in open ground for late crops. Sow seeds in hot-bed and cold-frame for second early. There are always little spaces in a garden where a few cabbages may be put; a plenty of plants should be provided.

Hot-beds.—This month will be the proper season for making hot-beds at the North. Select a dry, sheltered spot with a southern exposure if possible, and dig a pit of the required size to a depth of eighteen inches to two feet; this pit ought to be at least a foot wider and longer than the frame used, and be boarded up with any old boards. Fill with horse manure to the height of at least six inches above the surface of the ground, tramping it down firmly. Make the frame of inch hemlock boards two feet high at the back and one foot in front. After the manure has been put in place a layer of three to six inches of good light and rich garden soil on the manure. Bank up with earth around it; put on the frame; put the sashes on and let them remain for two or three days, or until the heat is reduced to about 90°, when the seeds may be sown. Sashes are usually 6x3 feet, but other sizes will answer. During cold nights cover with mats or shutters to keep the plants from freezing.

Cold Frames are made in the same way as hot-beds, except that no manure is used; the frame is put upon a spot where the soil is rich and carefully prepared. Stir the soil often until it is thoroughly warmed by the heat of the sun, covering at night to retain the warmth, and then sow the seeds of such plants as do not require strong heat, such as cabbage, lettuce, etc.

Cauliflower.—Treat the same as cabbage, sowing

Early Paris and Early Erfurt for early. Lenormand and Walcheren for late.

Carrots.—Early Horn is best for early, and in the garden best also for late; sow in drills one foot apart.

Celery.—Sow in hot-beds Dwarf White Solid and Boston Market.

Chis.—Cut away the dead tops early. To make a new bed procure a clump and divide it; set the single plants or small clusters in rows a foot apart, allow six inches between them. The tender green tops are cut up fine and eaten with vinegar.

Corn.—As soon as the ground is warm enough plant a few rows of Moore's Concord or other early. At intervals of ten days sow this and later Mexican Black but the sweetest, Mammoth Sweet, and Stowell's Evergreen. Sow in drills 2 1/2 feet apart.

Cress.—Sow Curled in shallow drills, one foot apart at intervals of a week.

Cucumbers.—A few hills of Early Russian may be planted on pieces of sod in a hot-bed; for general crop White Spine, and for late and pickles Green Prickly.

Egg Plant.—Sow seeds in the hottest part of the hot-bed; they require more heat than most plants. Long Purple for early, and Purple and Black Skin for late.

Horseradish.—Plant sets in rows two feet apart in well-manured ground.

Kale left in from last fall will need hoeing to keep down the weeds and promote growth. German Greens and Scotch kale are sown late.

Kohl-rabi.—Sow Early White in open ground in drills two feet apart.

Leek.—Sow Flag or Musselburgh the same as onions.

Lettuce sowed in the open ground last fall must be uncovered and the soil loosened between the rows. Set out plants from the cold-frame, and sow seeds in hot-bed and open ground. Curled Miesia, Hanson, and Tennis-ball are reliable sorts.

Melons.—Treat the same as cucumbers. Nutmeg, Cassaba, Skillman's Netted, White Japan, and Ward's Nectar are good.

Onions.—Sow early in very rich soil in drills fifteen inches apart. Plant out sets, potato, and top onions for early crop. Yellow Dauvers and Early Red are the best sorts for raising from seed.

Parsley.—Soak seeds in warm water, and sow Curled in drills one foot apart.

Parsnips.—Dig those left in the ground over winter, and sow seeds of Hollow Crown in drills fifteen inches apart.

Peas.—Plant over well-manured trenches in double rows, allowing room enough between the rows to place the brush. Laxton's Alpha, Carter's First Crop, and Daniel O'Rourke for early; Champion of England or Yorkshire Hero for main crop. For dwarf McLean's Little Gem. Sow the last in single rows eighteen inches apart, and not until the ground is well warmed.

Peppers.—Sow in hot-bed as egg plant. Squash for pickles and Sweet Mountain for stuffing.

Potatoes.—Start a few for early use in hot-bed. Those for planting in open ground may be cut and placed in a warm spot for a few days before planting. Early Rose is best for general crop of early. See notices of new sorts.

Radishes.—Sow thickly in drills in open ground at intervals of a week or ten days for a succession. French Breakfast, Early Scarlet Turnip, and Olive-shaped short sorts, and Scarlet Short-top long.

Salsify.—Dig the roots remaining in the ground, and sow seeds for the new crop as for parsnips.

Scorzoneria, or Black Salsify, requires the same treatment as salsify.

Spinach.—Uncover the beds planted last fall, and in a few days of warm weather it will be ready to cut. Sow seeds of Round Leaved in drills a foot apart for spring and summer use. New Zealand is best for summer, but is not sown until May.

Sorrel.—Uncover the plants and spade a dressing

of manure between the rows. It is excellent for early greens.

Sweet Potatoes.—Start in a hot-bed with two or three inches of compost over them, and when the sprouts are large enough, set in well-manured ridges. Nansemond and Southern Queen are best for Northern use. See article on page 89.

Squashes.—After the ground is warm sow Summer Crookneck for early; Boston Marrow, Marble-head, and Hubbard for late.

Tomato.—Start in hot-bed or window-box seeds of Trophy, Early Smooth Red, and Canada Victor.

Turnips.—Sow a few rows of Flat Dutch for early, and Red and White Strap-leaf for later. White French and Yellow Stone for ruta-baga sorts.

Seeds.—The supply of seeds should be ordered at once, so that they may be ready when wanted. The facilities for sending seeds by mail are now such that all the smaller varieties can be sent easily and cheaply by mail.

Flower Garden and Lawn.

Annuals.—Sow in hot-bed or window-boxes, so that there may be plenty of young plants to use in planting the borders.

Walks may be made as soon as settled weather comes; gravel and broken rock make the most durable walks.

Lawns.—Roll and sow plenty of grass-seed where the turf was injured during the winter. When new lawns are made prepare the soil by plowing or spading in well-rotted manure. Red Top or June Grass makes a good lawn when used alone, or both together, with a little white clover. Use plenty of seed, five or six bushels to the acre.

Perennials grow better if divided at least once in three years. Attend to this as early as possible before growth commences. If the soil is not already rich, make it so by adding plenty of fine manure.

Greenhouse and Window Plants.

March will bring with it an abundance of work in this department, the chief of which will be the

Propagation of bedding plants for out-of-door planting. The temperature of the air in the propagating house must be considerably lower than that under the benches.

Ventilation ought to be looked after carefully now that the sun is so powerful. Admit air every mild day, taking care however that none of the plants are exposed to draughts of air. Keep the plants near the glass, so that they will get all the light possible.

Smoking.—The greenhouse should be fumigated with tobacco smoke every week to destroy the green fly. If one smoking is not enough give another the next evening, always taking care to thoroughly syringe the plants the next day to remove the dead insects.

Forcing.—Such plants as were forced during winter should be turned out in a reserve bed to recover.

Bulbs that have finished flowering should be allowed to complete the growth of their leaves: after this cut off the leaves and store the bulbs in a dry place, where they can not be injured by cold or mice.

Commercial Matters—Market Prices.

The following condensed, comprehensive tables, carefully prepared specially for the American Agriculturist, from our daily record during the year, show at a glance the transactions for the month ending Feb. 13th, 1874, and for the corresponding month last year:

Table with columns: RECEIPTS, FLOUR, WHEAT, CORN, RYE, BARLEY, OATS, SALES, and corresponding values for 1874 and 1873.

Comparison with same period at this time last year. RECEIPTS: Flour, Wheat, Corn, Rye, Barley, Oats. 26 days 1874 vs 1873.

Stock of grain in store at New York. Wheat, Corn, Rye, Barley, Oats, Malt. Feb. 9, 1874 vs Feb. 9, 1873.

Exports from New York, Jan. 1 to Feb. 12. Flour, Wheat, Corn, Rye, Barley, Oats, Peas.

CURRENT WHOLESALE PRICES.

Table of current wholesale prices for various commodities like Flour, Wheat, Corn, etc., with prices for Jan. 13 and Feb. 13.

Gold has been up to 112% and down to 110%—closing February 12th at 112% as against 111% on January 12th. The receipts of Produce since our last have been on a remarkably liberal scale for the season—the railways bringing forward unusually large amounts, particularly of Flour, Wheat, and Hog products.

rather sharply. Wool has been in fair demand, mostly on manufacturing account, at stronger rates. The finer grades of Fleeces have been scarce. Hemp, Seeds, Hay, and Tobacco have been moderately sought after at the ruling prices. Naval Stores and Petroleum hold higher, and in more demand. A very moderate business has been reported in Hops, at essentially unaltered rates. Groceries have been sought after—Coffee and Sugars lower. The Cotton movement has been comparatively brisk; but with free offerings of stock prices have declined.

New York Live-Stock Markets.

Table with columns: RECEIPTS, WEEK ENDING, Beeves, Cows, Sheep, Swine, Total. Rows include weekly receipts and totals for 4 and 5 weeks.

Receipts.—After the dull course of last month's business the usual reaction took place, and a firm and upward feeling was manifested. The receipts during the month were irregular, and prices worked back and forth exactly according to receipts. On the whole, the past month has not been satisfactory to dealers, and some have lost money. At the close the market was dull, and prices were easier for ordinary and medium cattle, 1/2c. 1/2 lb. having been lost from the top rates of the day. Cherokee and Texan cattle brought 9 1/4c. @ 10 1/4c. 1/2 lb. to dress 56 lbs. 1/2 gross cwt.; prime native brought 8 1/2c. @ 12 1/2c. on 54 @ 58 lbs.; and a few of the best reached 12 1/2c. @ 13c.

Table with columns: WEEK ENDING, Range, Large Sales, Aver. Rows include weekly price ranges and averages for various livestock.

Milk Cows.—The market for cows has been quiet. All that came to hand have been sold at steady prices, and a moderate demand is reported at \$40 @ \$80 per head. Calves.—A steady demand exists for all that arrive, and good veals are taken readily at highest quotations. At the close, 8c. @ 11c. 1/2 lb. was paid for veals, and \$8 @ \$12 per head for grass calves. Hog-dressed veals were firm at 11c. @ 14c. 1/2 lb. Sheep and Lambs.—An increase in receipts, although trifling, has disturbed the market for sheep, and along with the weakness there has been a falling off of 1/4c. 1/2 lb. Choice lots bring high prices, and 8 1/4c. 1/2 lb. was paid at the close for this class of stock. The range was 6 1/4c. @ 8 1/4c. 1/2 lb. Swine.—The market has gradually crept up, and, with lighter receipts, quotations are considerably advanced. Live hogs sold at the close at 6c. @ 6 1/2c. 1/2 lb. Dressed hogs were in fair demand, at 7c. @ 7 1/2c. 1/2 lb. for Western, and 7c. @ 8c. 1/2 lb. for City.

Clubs can at any time be increased by remitting for each addition the price paid by the original members; or a small club may be increased to a larger one; thus; a person having sent 10 subscribers and \$12, may afterward send 10 more subscribers with only \$8; making a club of 20 at \$1 each; and so of the other club rates.

Mr. Judd's Health.—A paragraph has been going the rounds of the papers to the effect that Mr. Judd is seriously ill. This was news to us, who are quite as likely as other papers to know, and we can only say that his last and very recent letter was very cheerful, without any reference at all to his being ill.

Our Fine Chromos.—Read all about them on third cover page. It is easy to secure one or both.

New for the Senate!—The House has passed a much needed amendment to the Postal law, which interests all who send books, plants, and other matters by mail. When it becomes a law we shall endeavor to publish it in full.

Take Both Papers.—If both the American Agriculturist and HEARTH AND HOME are taken together they may be had for only \$4, and \$4.50 pays for both papers and a Chromo with each.

Grafting the Hickory.—"C. R.," Locktown, N. J. The hickory is among what the French gardener calls "sujets rebelles," or hard cases; and to graft it successfully requires great care on the part of the operator. At best it only succeeds on very young stocks, and the grafts when set have to be covered with a bell-glass to keep them from drying out, and a shade to prevent burning. Grafting the hickory may be considered, so far as people in general are concerned, as impracticable. A few years ago we published a communication from a gentleman who succeeded by drawing the earth away from small stocks, grafting in the collar by the usual cleft-graft, tying firmly, replacing the earth, and making a mound of earth to half cover the cion.

Death of a New Hampshire Horticulturist.—Mr. Calvin Eaton, of Concord, N. H., died suddenly of disease of the heart on January 14th. Mr. E. was prominent in the horticulture of his State, and was especially successful as a grape-grower.

Walks in a Lawn.—"J. T. P.," Chester Co., Pa. The walks in Central Park are made of various materials. The best, except on hill-sides where they will wash, are made of gravel, and if good gravel can be had and properly laid nothing can be better. The cement walks, so far as we know of them, are hampered with patents. One of our neighbors made his walks by melting three parts of coal-tar and one of pitch, mixing sand with this material to make a thick mortar, and spreading and rolling. This makes a good walk; but we do not know whether it interferes with any one's patent or not.

Triumph Sweet Corn.—A single trial of this variety convinced us of its great excellence, and we regard it as "tip-top" in every respect. Mr. D. C. Voorhes, Blavensburg, N. J., who brought this corn to its present perfection, has furnished us enough for a more extended planting this year, and we shall make another trial of it.

A Camellia with Two Centers.—Mr. David Foulis, Florist, 1466 Broadway, N. Y., brought us a camellia which had two distinct centers in the middle of the flower, while the exterior shows no indication that it was formed by the union of two flowers.

The English "Farmer"—not the tiller of the soil, but the paper absurdly so-called—continues to act out its natural instincts, and (in such a case it is not necessary to be very choice of words) steal from the Agriculturist and other papers with its accustomed freedom. If the articles thus stolen went no further than the obscure columns of the "Farmer," it would matter but little, but other English as well as American papers, seeing a good article in the Farmer, quote it and credit it to that sheet, and thus a double wrong is done—it steals articles and gets credit for publishing something readable under the false pretense of its being original. Our friend Robinson, of the "Garden," recently published, with credit to the Farmer, an article on "Carpeting Beneath Shrubs," copied from the Agriculturist word for word. The Garden should know that if anything appears in the Farmer worth quoting, it is quite sure to be stolen bodily from the Agriculturist or some other American paper, for nothing short of a stroke of lightning would ever arouse it from its profound stupidity and in-

duce it to perpetrate a readable article of its own. A burglar shows some daring in his crime, the pickpocket displays great skill, but the fellow who steals the coats from the hall while the family are at supper shows neither daring nor skill, and we call him a "sneak thief." A paper that persistently and continually takes others articles without credit does not belong to the first two classes, as his exploits are not marked by either of the qualities that we have attributed to them.

SUNDRY HUMBUGS.—Important Decision.

Many years ago, Mr. Judd found, from his correspondence, that quacks and charlatans of all kinds were fleecing the people, especially the agricultural community, at a rate that was perfectly astounding. He, at a great expenditure of time and at the risk of both person and pocket, began to investigate the complaints that came to him, and, when well founded, the evil-doers were exposed. Soon the humbug column became a regular thing, and it became necessary to employ assistants to look up the cases as they occurred. For a long time he fought the army of humbugs single-handed, though of late other papers have given more or less efficient aid; and it is satisfactory to know that the Agriculturist has been the means of saving to the people a sum that may safely be reckoned by millions. Whoever has had the editorial charge, the manifesto against fraud has regularly appeared, and it is intended it shall appear until the rogues find the business has grown unprofitable from their being unable to find dupes. A great help to our labors has come in the recent United States law against improper use of the mails; and we are by this enabled to squelch some very mischievous things in the end. It is not policy to tell how this is done, as we do not care to put rogues on their guard. Suffice it to say it is through the officers of the law. In exposing the designs of quacks and impostors of all kinds we may sometimes make a mistake, and do injustice to an innocent person, notwithstanding all the care we take in investigating and considering each case. The cases in which this has happened have been very rare, and we have hastened, when convinced we were wrong, to make the fullest reparation. We would not in any manner injure any one engaged in a fair and legitimate business, but, on the other hand, we will not allow those in unfair and illegitimate business to fleece confiding and unsuspecting people if any warning on our part can prevent it. Of course, in defending thousands from the designs of quacks and impostors, we must offend those who get up the swindling schemes, and some of these have money enough to enter a suit at law against us. We get "handed up" so often that we have become quite used to it; and though these fellows have it in their power to cause us to expend time and money to respond to their suits, we accept these as legitimate accompaniments of our position. Some prosecute us with the hope that the fact may be widely announced, and thus give them a capital advertisement gratis; others enter suits with the expectation of recovering damages. When we are sued we do not publish the fact, as we do not care to do that kind of advertising. Very few of these suits ever come to trial, and in the few that have been fairly brought before the courts, we have in no case been defeated. The last suit that was brought against us called forth such a positive opinion from Judge Davis of the Supreme Court of New York, that we are induced to print it in full. It is, indeed, a valuable contribution to medico-legal literature, and is of interest not only to the people at large, but to every publisher of a journal and every lawyer and physician. Nor is it without importance to makers and vendors of various nostrums; and this very calm bit of judicial wisdom is commended to their consideration. This opinion, copied from the court record, gives such a full and clear history of the case, that no further comment is needed.

SUPREME COURT.—FIRST DEPARTMENT. JANUARY GENERAL TERM.

DAVID RICHARDS, Plff. and Appt., vs. ORANGE JUDD AND OTHERS, Defs. and Resp. DAVIS, P. J. DONOHUE and DANIEL, J. J.

Appeal from order of Special Term, striking out the complaint in this action, and dismissing the same with costs, for plaintiff's refusal to answer certain questions propounded to him as a witness pursuant to the order of the Court.

JOHN L. WALKER for plaintiff; AMOS G. HULL for respondent.

DAVIS, P. J.: The plaintiff alleges in his complaint, in substance, that he is and has for many years been the sole proprietor, owner, and manufacturer of articles of medicines and merchandise generally and publicly known as Dr. Richan's Golden Remedies, which he has for ten years last past manufactured and put up and offered for sale



containing a great variety of items, including many good hints and suggestions which we throw into smaller type and condensed form, for want of space elsewhere.

Remitting Money: — Checks on New York City Banks or Bankers are best for large sums; make payable to the order of Orange Judd & Company. Post-Office Money Orders for \$50 or less, are cheap and safe also. When these are not obtainable, register letters, affixing stamps for postage and registry; put in the money and seal the letter in the presence of the postmaster, and take his receipt for it. Money sent in the above three methods is safe against loss.

Postage: On American Agriculturist, 12 cents a year, and on Hearth and Home, 20 cents a year, in advance. Double rates if not paid in advance at the office where the papers are received. For subscribers in British America, the postage, as above, must be sent to this office, with the subscription, for prepayment here. Also 20 cents for delivery of Hearth and Home and 12 cents for delivery of American Agriculturist in New York City.

The National Live-Stock Journal, which is a monthly journal published at Chicago, continues very worthily to represent the interests of stock breeders; it is thoroughly trustworthy, and is edited with great judgment and skill. It now comes forward as the defender of stock interests, being engaged in repelling an attack in the shape of a suit for damages for an expression of opinion upon matters of great moment to honest breeders.

and sold, and that by means of extensive advertising and the good qualities of such Golden Remedies he has secured large sales and profits.

He also alleges that the defendants are publishers of a monthly magazine known as the *American Agriculturist*, and having a circulation monthly of two hundred and fifty thousand copies; that in November, 1872, the defendants published in their said magazine a certain libelous article in the following words: "Sundry Humbugs.—Our newer readers keep inquiring about the trustworthiness of this, that, and the other doctor for various diseases. We answer that every so-called physician, every medical institute or college or association that advertises medicine or medical advice, by circular or otherwise, is a quack—in short, a swindle. The whole tribe of those who advertise 'marriage guides,' 'female medicines,' 'advice to the young,' 'errors of youth,' 'eye doctors,' 'ear doctors,' 'consumption cures,' 'cancer doctors or medicines, etc., etc., are positively quacks and impostors, to whom it is unsafe to address even a letter of inquiry; also the 'Golden Remedies' inquired about by several are nonsensical quackery. We have not room for a lot more of humbugs on hand, but will renew the war upon them in the next volume, and, as hitherto, we expect to shield at least all our readers from swindlers, and through them many other people."

The plaintiff alleged also that the defendants, by means of these words published as hereinbefore set forth, insinuated and meant to be understood by those to whom it was published and to the public at large, as charging the plaintiff with being a quack, impostor and swindler, and that the said "Golden Remedies" manufactured solely by the plaintiff were wholly valueless and useless, and possessing no medicinal qualities whatever, and that by means of the publication the plaintiff has been injured in his reputation and in his business, and been deprived of custom and trade, and lost the sale of goods and profits which he would otherwise have made, to his damage, twenty-five thousand dollars.

The defendants in their answer admit in substance that they are publishers of the *American Agriculturist*, and that in December, 1872, they published the article under the caption of "Sundry Humbugs," above set forth. They allege also that the publication is substantially true, and was published with good motives and for justifiable ends. They also set out *in extenso* the circulars sent forth by the defendant with his "Golden Remedies," in which the plaintiff describes himself as a physician who has had a general practice in all parts of the world; and aver various facts tending to show that the alleged medicines of plaintiff are valueless as remedies for disease, being compounds costing but a few cents per bottle, and selling at several dollars, which the public would shun if the constituent facts were known.

The defendants propose in their answer to give evidence of all the various facts alleged both in justification and in mitigation of damages.

Issue being joined, the defendants upon affidavit procured an order and summons for the examination of plaintiff as a witness on their behalf before the trial.

On such examination the plaintiff testified that a bottle marked "Doctor Richan's Golden Remedy, No. 2," was one of the medicines he advertises and vends to the public.

He was then asked of what Balsam No. 2 is composed. He refused to answer the question, on the ground that it was irrelevant, immaterial, and a secret in his trade.

The judge directed the plaintiff to answer the question.

He then answered: "It is a secret compound composed of various ingredients which possess great medicinal properties," and refused to state the names of the ingredients.

He then gave evidence showing that he was not a doctor of medicine and had never received a diploma, and had not been engaged in a general practice of medicine in any part of the United States.

He then testified that he advertised "Doctor Richan's Golden Elixir de Amour, or Elixir of Love," and on being asked "of what is it composed?" he refused to answer.

The Court at Special Term, after argument, ruled that the plaintiff must answer the question which had been propounded; and on the question being repeated to him he answered: "It is a secret compound of various ingredients which possess great medicinal properties," and refused absolutely to give any other answer.

On presentation of these facts to the Court it was held that the answer was evasive; and the plaintiff, under the advice of his counsel, refusing to give any other answer, the Court ordered his complaint to be stricken out and dismissed with costs.

By the allegations of his complaint the plaintiff had invited an issue as to the medicinal qualities and value of the "Golden Remedies."

The statement of the alleged libel, so far as it pointed directly to plaintiff or his remedies, was to the effect that his "Golden Remedies" are "nonsensical quack-

ery," and it is chiefly of this statement that the plaintiff complains.

The defendants undertake by their answer to show that this statement is true.

No one can read the circulars of the plaintiff, as proved by himself on his examination, without observing the importance of the investigation sought to be made. It was competent to disprove the assertions of the circulars and of the complaint by ascertaining the ingredients of the several compounds for the purpose of showing that they possess no such medical virtues as are claimed by plaintiff. For instance, he asserts in his circular that his "Elixir of Love is composed of the most powerful ingredients of the vegetable kingdom—harmless, but speedy in restoring healthy action." And again: "It is the fountain of youth to old age, the rejuvenator of pristine vigor in the young; to the barren woman of our land it is a special blessing." Indeed, it is impossible to read the vulgar and in many respects shameful assertions and instructions that accompany the compounds of plaintiff without being struck with the vileness of the impostures. That he can bring an action of libel for injury alleged to be done to his trade in his medicines by denouncing them as arrant quackery, and at the same time protect himself against exposure by claiming them to be valuable secrets, is a proposition that can not be maintained. *Byrn vs. Judd*, 11 Abbott, New Series; 11 New York, 347, New Series.

In the laudable exposure of such "humbugs" as the pretended medicine of plaintiff and others, the defendants take upon themselves great risks, and subject themselves to the annoyance of suits; but I think they are not exposed to any danger that courts will interpose any shield for the protection of parties guilty of fraud and deception of the public.

If the plaintiff did not choose to try the question of the true character of his "Golden Remedies" he should have kept out of a court of justice.

The order of the Court below was correct, and should be affirmed with \$10 costs and disbursements.

In view of the length of this opinion, we must let the bulk of our budget of humbug literature rest for this month. It presents some new schemes, but all in the old style, save one or two novelties that we are investigating. It will be timely to advise our farmer readers not to invest in "Ivory" or any other wheat at \$1 for 100 grains. A variety possessing such qualities as this does not first make itself known through an obscure circular. As it came from Africa, we suspect it is not a wheat at all. . . . If people will send money to "Furnishing Companies" in Chicago or elsewhere and get no returns, we can only say to the gentlemen who write from Missouri and Wisconsin that we regret they did not read their *Agriculturist* more thoroughly. We can not comply with the request of our correspondent who requests us to put him on our "list of fools." He had better pocket his loss and take the lesson to heart.

Roses by Mail.—Massey & Hudson, Florists, Chestertown, Md., in sending us one of their packages of roses, say they "would like to call your attention not only to the plants themselves, but to the box and manner of packing, both of which we claim as original, and which for simplicity, light weight, and effectiveness, we don't think can be beaten." Well, that is just what we think. If one can get eight vigorous, well-rooted young roses delivered in any part of the country for \$1, we think we should be a rose-growing people, which we are not.

Pupils in Horticulture.—We often have applications from those who wish situations to learn gardening in its various branches; but such places are difficult to find. We now know of a gentleman upon whose place—a private one near New York—most of the operations of horticulture are carried on. He offers to take a student, provided a suitable young man offers. None need apply but those who have a positive liking for horticulture and are fond of both study and work. Address, stating age and previous experience, "Horticulture," at this office.

Sebright Bantams.—James Shepard, of Bristol, Ct., sends us portraits of these beautiful pet birds, which he breeds to great perfection, as he does other choice fowls.

Ohio Dairymen's Association.—The tenth annual meeting of this association was held in Cleveland on the 25th and 29th of January. The number of members is 134, and \$136 were received into the treasury last year. The usual matters connected with dairying were talked of and discussed, and W. A. Jenkins, of Portage, was chosen as President, and S. D. Harris as Secretary and Treasurer for the ensuing year.

FREE.—Fine Gold Pens, with Silver Cases—The Best Silver-plated Table Articles—Table Cutlery—Children's Carriages and Toys—Floral Sets—Garden Seeds and Flower Bulbs—Sewing Machines—Washing Machines and Wringers—Pocket Knives—Fine Gold and Silver Watches—Melodeons—Pianos—Guns and Rifles—Cultivators—Books—etc., etc., etc.; all these are among the valuable articles to be found in the Premium List for 1874 on page 119. Any person can, with a little effort, secure one or more of these valuable articles. Thousands have done it. There is room for thousands more. It is very easy to obtain clubs of subscribers for the two popular papers, the *American Agriculturist* and *HEARTH AND HOME*. Try it.

A Botanical Directory.—The Torrey Botanical Club have issued a Directory giving the names and residences of all the persons known to them as being engaged in botanical pursuits in North America and the West Indies. The names are first placed in alphabetical order, and in the second part they are arranged according to states. The directory forms a part of the monthly bulletin of the club, which is sent to subscribers at \$1 a year. The price of the directory alone is 30 cents, and may be had by addressing the editor, W. H. Leggett, 224 East 10th street, New York.

The Banking House of Fisk & Hatch was forced to suspend during the panic, but having adjusted their affairs and being able to meet all their liabilities they resumed in December last. No firm in New York enjoys to a greater degree the confidence and esteem of business circles than Fisk & Hatch; and as their temporary suspension produced a feeling of profound regret, so the announcement of their resumption has been hailed with the most sincere pleasure by a host of friends. It is safe to say that they resume business with a stronger hold than ever upon the confidence of those with whom they have had business relations. This confidence was most substantially exhibited in the fact that during the first twenty-four hours after their resumption not a dollar of deposits was withdrawn, while a large amount of new deposits was received. The firm is now paying the semi-annual coupons on \$31,620,000 bonds of the Central Pacific, Western Pacific, and California and Oregon Railroads.

Hussey's National Cottage Architecture, or Homes for Every One. Chiefly Low-priced Buildings for Towns, Suburbs, and Country. By E. A. Hussey, architect. New York: Geo. E. Woodward, Orange Judd Company.—It sometimes happens that a work is offered which seems to exactly fill a gap in the class of literature to which it belongs. This is the case with the work the full and descriptive title of which is given above. It contains numerous designs of cottages and small houses ranging in cost from \$1,800 to \$3,000 and \$4,000, with a few still more costly ones. The designs are of an exceedingly neat and tasteful character, the division of the interiors well considered, and the ornamentation, while effective, not elaborate. Elevations, perspective views, and details are given with each design. Specifications to some of the plans are given which serve as a guide for drawing up such forms for others. The execution of the work is excellent, and is a handsome specimen of book-making. We have not in a long time seen a work which seemed to so exactly meet a general want, or one we could so heartily commend to those who propose to build. Price \$6.00.

A New Thrashing Machine in which the cylinder and concave is without spikes, is made by Wheeler & Melick Company, Albany, N. Y. In this machine the straw is not broken, but is carried from it sideways in a proper condition for tying up in bundles for sale, the same as hand-thrashed straw. The passage of the straw is more rapid than in the ordinary machine, and 250 to 450 sheaves may be thrashed per hour with a two-horse tread power.

Improved Hay Press.—P. K. Dederick & Co., Albany, N. Y., have an improved hay press in which bales of any size, from 100 lbs. upwards, may be made. The hay may be pressed, either long or cut into short fodder, and by an additional contrivance the hay may be weighed so that every bale is of the same weight. The cut hay is baled in a "perpetual press," and to prevent waste in using, the bales may be made as small as 25 pounds if desired.

See Page 119 and Third Cover Page.

Bugs in Peas.—"W. M. S.," Vancouver, Wash. Terr.—Tell your neighbor that when bugs once get established in a locality it is difficult to get rid of them. One of the best methods is to plant the peas intended to be saved for seed as late in the season as they will ripen. In your moist climate this ought to be practicable; and if all the growers in a neighborhood will adopt this the bug will die out.

The Early Beatrice Peach.—The *Agriculturist* was, we believe, the first journal to call attention to this variety. Some three years ago we noticed the receipt of specimens of the fruit from North Carolina and have kept watch of its progress since. Our trees were injured by the severe cold of last winter, but it has been fruited in a number of localities since. Colonel Edward Wilkins, of Kent county, Md., who is probably the largest peach grower in the world, has planted largely of the Early Beatrice. Hale's Early, heretofore our earliest variety, in most localities rots badly, while this is from ten to twenty days earlier, ships well and, as far as heard from, is free from rot. It is worthy of the attention of peach growers, and if it fulfils its present promise will add another leaf to the pomological laurel that crowns the venerable head of Thomas Rivers, its originator.

Gold Fish.—"A Female Subscriber" writes that the gold-fish in her aquarium will die, but as she tells us nothing about the aquarium we are unable to do other than guess. We guess that the fish die because the aquarium is in too warm a place or because they are not fed. The remedy for the first will suggest itself; for the other, roll soft bread into small pellets the size of duck shot and offer every few days. Remove such as are not eaten.

A Guinea Mower.—English horticultural papers announce a new lawn-mower which is claimed to be effective in all respects and is sold for a guinea. This is what our makers will ultimately come to. Who will step in first and make a fortune by offering a five-dollar mower? At this price great numbers of people whose grass plots are too small to warrant their using the present machines at \$15 to \$25 and upward, would purchase a small and effective one if sold at \$5. Of course, such a machine as this will not answer for those who have a large surface of grass; these will continue to buy the large machines. The \$5 machine would find its sale among those who have none at all.

Malt Dust.—"J. W.," Hollidaysburg, Pa.—Malt dust would be a useful fertilizer for berries, etc. We can not say what the value of it is, as it is not much used in this country. In England fifty to sixty bushels to the acre is considered a good dressing and equal to an ordinary manuring with other fertilizers.

Mucilage, etc.—"Yosemite."—Assuming you refer to mucilage of gum arabic, it may be kept from "becoming stiff" by keeping it covered; if too thick add water. We have not found it necessary to use anything to prevent souring. Make in small quantities at a time. We know nothing of the firm inquired about. Letters upon household and all other matters come to the editor, who distributes them to his associates according to their contents.

Dollars and Greenbacks.—"A. D. F.," Iowa.—The questions you propose are of a kind upon which widely differing opinions are entertained, and we could not give space to the discussion that an opinion either way would open. A sufficient answer to your first question is the fact that gold is the standard of value in all civilized countries.

Pear Trees.—"J. G.," Illinois.—The north side of a hill is preferable to the south; many prefer a north-east exposure to any other. The Bartlett is the pear found better adapted to a great variety of situations than any other and it is more profitable. Probably nine trees of this are planted to one of any other sort. For other varieties you should take the experience of those who have grown pears in your neighborhood.

Tuberous Chervil.—If any of our readers cultivate this we would like to have their experience. The seeds are offered by some of our seedsmen, but we never succeeded in making any grow, and we learn from a French journal that unless sown soon after ripening it rarely germinates.

Hedge.—"R. I. T.," Bricksburg, N. J.—The honey locust would make the best hedge for your locality.

Willows.—"J. W. H."—Cuttings from the size of the little finger to two inches in diameter and

from a foot to three feet long may be set a foot apart, making holes with a dibble or crowbar. But it is of no use to set them unless you can keep the ground around them clean and cultivated until well established.

Norway Spruce.—"B. L. H.," Mich.—For a screen with trees in a single row, six feet apart is the proper distance. When vegetation is scarce, especially if snow is on the ground, sheep will eat almost any green thing, and we should not be surprised if they nibbled the spruce.

Rational Horse Shoeing.—"E. H.," Benton, Wis.—This work is sent from this office by mail for \$1.

Double Geraniums.—Miss "C. F. G.," Accomac Co., Va.—These need no treatment different from the single. In pots a better bloom may be had by moderate use of liquid manure.

Camellias.—Mrs. "J. T. B.,"—Camellias drop their buds because the air is too dry. When growing they need a warm place, at other times a room where they will not freeze will answer. Can't advise about pruning without seeing the plants. No plants should be watered every day or every other day, whether they need it or not. Give water according to the kind of plant and its condition. Better allow the soil to get too dry now and then than to keep the roots constantly soaked.

The Blue-Grass Region of Kentucky.—"J. H. A.," Coleta, Ill. The blue-grass region of Kentucky comprises all that part of the State where there is a limestone soil; where the sandstone predominates this grass, although it will grow, does not flourish as upon the limestone. The so-called blue-grass region lies across the middle of the State, and covers about twenty counties, including an area of 12,000 to 15,000 square miles.

Saving Manure.—"H. D. B.," Ulster Co., N. Y. You will find descriptions of sheds for making and saving manure in articles in the *Agriculturist* of last month, as well as the present month.

Cranberries.—"M. E. D.," Vineland, N. J.—The fruit is borne upon the growth of the preceding year. Your other questions have been answered in other articles.

Becoming a Farmer.—"R. E. M.," Pittsburg. A careful, cautious man apt to learn, especially one who has been brought up to a mechanical trade, and therefore taught to use both his brains and hands, might soon learn to become a successful farmer. The first year he might expect to learn enough to enable him to pull through the second year with credit and more or less satisfaction. He should, however, closely watch his intelligent neighbors and consult with them, and not be ashamed to ask questions when necessary.

Web-Footed Hens.—"Old Subscriber," Fall River, Mass. The American Coot belongs to a family very distinct from that to which the hen belongs. Besides, it is not web-footed, but has its toes only margined with a membrane. If there is a race of web-footed hens in your locality we should be glad of a description of them, or a specimen, as you suggest.

Animal Dust.—"J. D. S.," Livingston Co., N. Y. Animal dust is the dried refuse of slaughtered animals, blood, bones, and offal, dried and reduced to powder. It is one of the most valuable fertilizers, and is now manufactured entirely pure and free from adulteration.

Foaming of Cream.—"Yosemite." When cream stands too long before churning in the winter time it foams up and "swells" in the churn, requiring longer churning, and sometimes refuses to come into butter at all. Too low a temperature in the milk-room also produces the same effect. The butter produced under such circumstances is inferior both in color and texture. The only preventive is to maintain a temperature of at least 55 degrees in the milk-room, and not to keep the cream more than four days before churning.

Fresh or Decomposed Manure.—"Peachblow." Since the year 1853 there has occurred a great change in the methods of culture of potatoes. Since that time the potato-rot has been very prevalent in places where it was previously unknown. It has been found that fermenting manure greatly promoted disease and assisted the growth of the destructive fungus; consequently its use has been abandoned, and thoroughly

rotted manure used instead. In England, where the moist climate is favorable to the potato disease, it has been found that superphosphate used alone tended to prevent its appearance, while with well-rotted manure the disease partially appeared, and with fresh manure the crop was totally destroyed. The author you refer to, who wrote twenty years ago, would probably greatly modify his views now in the light of our present information.

What came of a Windmill?—"J. T. Smith," Cedar Rapids, Iowa, gives his experience with windmills. He made a windmill of the pattern figured in the *Agriculturist* of May, 1872, with which he ran a small corn mill which ground one bushel per hour, by the addition of a 30-inch pulley upon the shaft of the windmill and a six-inch pulley upon the corn mill, and a 3/4-inch rope. He concluded that he had the cheapest power possible at the cost of only a few dollars until a sudden storm tore his mill to pieces. After some experiments he finally applied narrow strips, 4 feet long, to the arms, giving one square foot of surface to each strip. There are 106 of these strips upon a wheel, 12 1/2 feet in diameter, with which he is able to run a double corn sheller. When not in use the wheel is turned edge-wise to the wind. The mill, which is as simple as a common spinning wheel, cost \$12 for material and labor.

Manure for Cucumbers.—"B. S. H.," There is no special manure that is equal to barn-yard manure for any crop. But if barn-yard manure can not be procured, the next best fertilizer is a mixture of guano or hen manure, wood-ashes, plaster, and fine bone-dust in about equal proportions. They should be mixed quite dry, and used as soon after mixing as possible.

Permanent Whitewash.—With the return of spring comes the usual inquiries for a good whitewash. We have only to repeat the following directions given before, as follows: Take half a bushel of unslaked lime, slake it with boiling water, covering it during the process to keep in the steam; strain the liquid through a fine sieve or strainer, and add to it a peck of salt previously well dissolved in water; three pounds ground rice boiled to a thin paste, and stirred in boiling hot; half a pound Spanish whiting, and a pound of clean glue which has been previously dissolved by soaking it first, and then hanging over a slow fire in a small kettle inside a large one filled with water; add five gallons of hot water to the mixture, stir it well, and let it stand a few days covered from the dirt. It should be put on quite hot; for this purpose it can be kept in a kettle on a furnace. A pint of this mixture will cover a yard square of the outside of a house, if applied with a large paint-brush.

Feed Barrow.—In reply to many inquiries we would say that the feed barrow figured in the *Agriculturist* of January, 1874, is one that was made by one of the editors of this paper for his own use. The barrel was an iron-bound wine cask of 18 gallons and the arms were of hickory, steamed and bent into shape. The whole cost of the wheelwright's work was \$4, the rest of the work was done at home and really cost nothing but a few cents for bolts. A farm workshop ought to contain every necessary for making such an article.

Crops for Sowing to Grass.—"W. B.," Templeton, Mass. Neither Hungarian grass nor millet is a good crop to sow grass or clover seeds with. One serious objection against them is that they come too late, while these seeds should be sown early. If the soil is well prepared and in good order no foster crop is needed and the grass seed may be sown alone. We have raised an excellent stand of grass in this way, especially one of orchard grass, which, sown in April, might have been cut in July for hay. For clover it is preferable to sow it in this way, and, if the ground is rich and well prepared, it may be cut the first season.

"Hooks or Haws."—"E.," Madison, Ohio. When the eye is destroyed and the hooks are affected with a fungoid growth, the best remedy is a solution of nitrate of silver applied to the diseased parts with a camel's-hair pencil. It is quite possible that the removal of the diseased membrane by means of a sharp and pointed pair of scissors would be the simplest and best method; now that the eye is gone there is no use for the hooks.

The Cornell University.—The Register of this institution for 1873-74 is received—an exceedingly neat volume, which does credit to the University press from which it is issued. As an academic and technological college this seems to be meeting with a fair share of success. It has 461 students, and its faculty,

including residents and non-residents and instructors, numbers nearly fifty, and includes some gentlemen especially eminent in their specialties. We find the professorship of agriculture vacant, which perhaps it might as well be, as to be filled by a fresh importation from a country so unlike ours as England. And moreover, in the whole 461 students there are only seven recorded as in the course of agriculture. It is quite fair to say that the sinking of the Congressional agricultural college grant in this university was a great mistake. So far as agriculture is concerned the income of nine hundred and ninety thousand acres of land edneates just seven students. It takes the income of 141,423 acres of the land granted to the State of New York, which, at the government price of \$1.25 an acre—and we are informed that much of the land is worth much more—should at six per cent yield over \$10,000. It may be said that here are the opportunities, and it is the fault of those who wish to study agriculture if they do not avail themselves of them. We are not of those who charge the management and especially Mr. Cornell with improper discharge of their trust. We have seen nothing in the recent reports of the investigation of the affairs of the university to show that thus late in life Mr. Cornell has changed his character for benevolence and honorable dealing. The whole matter is simply a mistake on the part of both the New York Legislature and Mr. Cornell—a huge blunder which both parties should set about repairing as soon as possible. Had either of them known the simple horticultural fact that many plants, in themselves of the most robust nature, will not live under the shade and drip of other plants, they would have never made the mistake of exposing an agricultural school to the adverse influences of an academic one. No matter if there be no outward assumption of authority on the part of those in the academic courses, farmers' boys do not like to be even in contact with those who are pursuing branches to which they can never hope to aspire, and they will not go where they will be looked upon as in a lower grade of scholarship. The huge mistake of trying to do too much at Cornell with the national grant, has resulted, so far as agriculture is concerned, in doing so little that it may be called nothing. Unless some plan can be devised for making the grant more useful to agriculture where it now is, it were better that the contract be annulled and the fund placed where the rising generation of farmers may receive some benefit from it.

We are glad to observe that in the present Register the pedantic "trimester" is abandoned and the generally accepted word term is used to designate the division of the year.

Our Responsibility for Advertisements.

An individual in Michigan bought some corn that was advertised in the *Agriculturist*, and because the corn did not turn out as he expected, he thinks he has a claim upon us for damages, and threatens if we do not pay them that he will advertise us. As we believe in advertising, we shall not make it "write" with our Michigan friend, but hope he will proceed to carry his threat into execution, even to the extent of not taking the paper "enny more." We wish to say a word to this irate gentleman from Michigan as well as to other readers. We do not allow persons of known disreputable character, or even of doubtful reputation, to advertise. All the seedsmen who advertise are such as we believe will send exactly what they offer. Our directions to the advertising department are to receive no advertisement whatever of a doubtful or suspicious character. The corn complained of was the Sanford corn, advertised from Jamesport, Long Island. The purchaser does not complain that he did not get Sanford corn, but that it did not ripen as soon or yield as much as he expected. We know of no process by which we can supply people with brains. If this Michigan gentleman had seen an advertisement of a particularly productive pineapple or banana, he would probably have ordered it, and then complained that it did not give him any fruit. Now, any one who has sense enough to grow corn at all, knows, or ought to know, that there is no plant more affected by the conditions of climate and soil. In Canada they have a variety of corn that will perfect itself even as far north as Hudson's Bay; yet if a Canada planter were to get his seed-corn from Virginia, and make a failure, it would not be due to the poor quality of corn, but to his own ignorance. Our Michigan friend, who lives 50 miles north-west of a part of Michigan in which we have seen frost every month in the year, and the corn-fields blackened on the 5th day of July, gets a corn from Long Island, where they have the mildest winters and the longest growing seasons of any part of New York state, and expects it to be snited to his climate. He may, after several such blunders, learn that there are certain varieties of corn snited to his climate and others that are not. Then again, after all that has been said about novelties in the

Agriculturist, we have not the least sympathy for a man who relies for his main crop upon a new and untried thing; for we have given so many warnings against it that whoever does so can not blame us. One who has a new variety advertises it at a high price. It is well that new varieties should be introduced, and it is well that those who offer them should get a good price; for once out of their hands they lose all control over them.

A sensible man in seeing a new thing, corn, for instance, advertised, will order enough to test and, if it is found valuable, furnish him with a supply of seed for another year. He invests a sum the loss of which he will not feel should his new corn prove a total failure, for like a wise man he has depended upon a well tried kind for his main crop. Now we have no doubt that with the advertiser on Long Island, the Sanford corn "in many instances has ripened in 85 days from planting," any more than we doubt that in some other localities it is as useless a variety as can be planted. Would this Michigan man have ns put under the advertisement of Sanford Corn—"N. B. People who live in Central Michigan must not try this corn?" We assume that our readers have common-sense and some knowledge of geography and climate, and that a man, if he is a corn-grower in Michigan, will not be foolish enough to depend upon seed from Florida or any other place where the climate is different from his own. So with other seeds of novelties. We have a tolerably wide acquaintance with seedsmen, and we know that as a class they are exceedingly careful and conscientious. They know too well the money value of a good business reputation to risk it by offering anything that they know or suspect to be a humbug. They must offer novelties, for the public expect and demand them, and they must in all new things depend upon the statements of others, but they do not warrant onion seed to produce onions in Georgia, or cotton-seed to give a paying crop in Minnesota. They send out their catalogues supposing people of intelligence enough to read them have some knowledge of the capabilities of the country in which they live. Michigan man will please take notice that while his concluding threat has no terrors for us we give it for the benefit of the school authorities of his state: "if you don't do enything about this I don't think I shall take it enymore, and I will advertise it to." Advertise us by all means.

The Patrons of Husbandry

The annual meeting of the National Grange is in session at the time we go to press. Such portions of its proceedings as are allowed to be made public have been given in the daily papers all over the country. This meeting has been looked forward to, not only by the patrons themselves, but by all who have from one interest or another watched the movement, as one which will have an important bearing upon the future of the order. Those who wished it well hoped that this meeting would so act as to give the order strength and permanence, while those who had a political interest in the matter looked for some action that should make it useful as a political machine. The opening address of Grand-Master Adams as well as the action of the Grange thus far can have given very little hope to the politicians, while all that has been made public of their transactions has been marked by a moderation and thoughtfulness that must commend it to all, whether friends or opponents. There never was a stronger illustration of building "better than he knew" than is presented by the Patrons of Husbandry. For years of an insignificance almost ridiculous it began to grow, and when the general agricultural mind was in that state that it needed a nucleus around which it could crystallize, in order to give force and embodiment to its thought, the organization was ready at its hand with sufficient machinery to bring farmers together and give expression to their wishes. There are now over 6,000 granges with a membership of over a million. That unforeseen difficulties should arise from a growth so unlooked for, and that an organization which anticipated a limited membership, should be embarrassed by new questions, is not to be wondered at, nor is it strange that now and then a grange should withdraw from the organization. We may trust that difficulties, as they arise, will be met with the discreet decision that has thus far marked the action of the National Grange. The "declaration of purposes" by the National Grange comes just as we are closing these pages. It is a document that we should gladly publish in full were not our columns already closed. So well considered, so clear, and altogether so admirable a document, in sentiment and purpose, does not often emanate from any organization. While we commend it as a whole to all who wish to know about the Patrons of Husbandry as the latest exponent of their principles, we can not refrain from publishing an extract which is a part of the second article:—

"We heartily indorse the motto: 'In essentials,

unity; in non-essentials, liberty; in all things, charity.' We shall endeavor to advance our cause by laboring to accomplish the following objects:

"To develop a better and higher manhood and womanhood among ourselves. To enhance the comforts and attractions of our homes, and strengthen our attachments to our pursuits. To foster mutual understanding and cooperation. To maintain inviolate our laws, and to emulate each other in labor. To reduce our expenses, both individual and corporate. To buy less and produce more, in order to make our farms self-sustaining. To diversify our crops, and crop no more than we can cultivate. To systematize our work, and calculate intelligently on probabilities. To discountenance the credit system, the mortgage system, the fashion system, and every other system tending to prodigality and bankruptcy."

Catalogues Received.

So many catalogues are at hand that our notice of each must necessarily be brief. They are named in the order of receipt. We must request our friends not to write asking which nurseryman or seedsman they should purchase of. We do not notice the catalogues of or admit the advertisements of any who we have reason to believe will do other than fairly by their customers. Our advice always is to purchase—other things being equal—of the dealer nearest home, for the reasons that it is advisable to encourage local trade, and especially in the case of trees, one is likely to receive the articles in better order. The present mail facilities allow one to procure seeds and small plants from any dealer he prefers. We would add the often repeated advice to order early, whether seeds, plants, or trees.

SEED CATALOGUES.

WASHBURN & Co., Boston, Mass.—A large descriptive volume of about 130 pages, including several specialties, and embellished with a handsome colored plate of a bouquet of flowers.

ALFRED BRIDGMAN, 876 Broadway, N. Y., sends two compact catalogues, one for vegetables and the other for flowers. This old establishment is quite up to the newer ones in presenting the novelties of the season.

VANDERBILT BROTHERS, 23 Fulton street, N. Y., offer the standard vegetable and flower seeds, fertilizers and agricultural implements. Many of these last are illustrated.

G. A. LAW (Dudley Seed-farm), Roslindale, near Boston, Mass., has an "advance catalogue of flower and vegetable seeds of his own raising and importation."

PETER HENDERSON & Co., 35 Cortlandt street, N. Y., send a very full and exceedingly neat illustrated catalogue, which, besides the usual varieties, has numerous novelties in both vegetables and flowers. This is accompanied by a fine colored plate of a group of pinks.

WOOD & HALL, Geneva, N. Y., offer a handsome list of seeds and garden requisites, prefaced by useful instructions and offers of premiums to purchasers.

J. M. THORBURN & Co., 15 John street, N. Y.—This old and well-known establishment does not send out such showy catalogues as some others, but their exceedingly neat and compact vegetable and flower lists, which are published separately, show that they are as wide awake for novelties as their competitors.

CHASE BROS. & WOODWARD.—This comparatively new firm adds another to the list of Rochester, N. Y., seedsmen. Their catalogue is not behind the rest in showing a well considered selection of flower and vegetable seeds, many of which are raised on their own grounds.

R. D. HAWLEY, Hartford, Ct., has a neat illustrated catalogue of garden seeds and agricultural implements.

NICHOLAS COLE, Pella, Iowa, grows all the seeds that can be raised in his locality, and claims that Iowa-grown seeds are of superior quality. His list includes the standard varieties of vegetables and flowers and the novelties.

CROSMAN F OS., Rochester, N. Y.—The Crosmans, father and sons, have long been known as reliable seed growers. Their catalogue gives home-grown and imported varieties, with some specialties of their own.

KERN, STEBER & Co., St. Louis, Mo.—St. Louis shows her metropolitan character in various ways. In this seed catalogue we have a list quite as large as that sent out by any New York establishment. It is surprisingly full in every department, and contains several varieties that have a peculiar Western reputation.

BRIGGS & BROTHER, Rochester, N. Y., like some other dealers, publish their catalogue as a quarterly. They have adopted the title, "Illustrated Floral Work," and the number for January contains their full seed catalogue. In elegance of illustration and style in paper and print, this is a wonder in the way of catalogues. It is

filled to repletion with old and new things in flowers and vegetables.

D. H. BROWN & SONS, New Brunswick, N. J., send a catalogue of the leading vegetable seeds, and follow the English plan of offering premiums for the best exhibition at their store of varieties raised from their seeds.

R. H. ALLEN & Co.'s catalogue of garden, flower, and field seeds and grains is a characteristically neat production. Besides the standard varieties and current novelties, the portion devoted to garden implements is very full and well illustrated.

D. T. CURTIS & Co. (successors to Curtis & Cobb), 161 Tremont st., Boston, Mass., send three catalogues, one each devoted to flower and vegetable seeds, and the third contains the novelties of the year in both departments. Besides the matter of a catalogue, they give a list of the leading agricultural and horticultural journals and books.

YOUNG & ELLIOTT.—This old-established firm, at No. 9 John street, send out a catalogue containing all the usual varieties of vegetables and flowers, with several special novelties of their own.

SUTTON & SONS, Reading, Eng., send us their "Spring Catalogue and Amateur's Guide," a large and very elegant volume, and the only foreign one we have seen that approaches the catalogues of some of our seedsmen. The wood-cuts are generally of great excellence, but the colored plates do not equal those of Peter Henderson & Co., Vick, Bliss & Sons, Briggs Bros., and others in this country. It is a very full and interesting document, as becomes a catalogue of such a widely known house.

NURSERY CATALOGUES.

ARTHUR BRYANT, JR., Princeton, Ill., sends a catalogue of the best varieties of fruits, and pays especial attention to evergreen and deciduous ornamental and forest trees.

DUTCHESS NURSERIES, Poughkeepsie, N. Y., are now conducted by W. L. Ferris, Jr., & Co., who succeed L. M. Ferris & Son, and propose to keep up the reputation of the establishment for furnishing "their customers with such stock that they will merit further orders."

BLOOMINGTON (Ill.) NURSERY.—Our friend, F. K. Phoenix, has outgrown Bloomington, and has run over into Normal with his extensive nurseries. He offers about everything that any one has in the way of nursery stock in his own original style.

PINE GROVE NURSERY, Wm. Horton & Son, Allen's Corner, Cumberland Co., Me., offer fruit and ornamental trees, especially adapted to the colder parts of the country. They emphasize the sensible advice to plant young trees, and offer young evergreens from the forest at ridiculously low prices, and give proper directions for planting them.

S. B. PARSONS & SONS, Flushing, L. I., N. Y., devote themselves especially to ornamental evergreen and deciduous trees and shrubs. They make a specialty of rhododendrons, camellias, azaleas, and some other plants of slow growth, as well as of tender and hardy roses. That the plants sent out by Mr. J. R. Trumpy, the celebrated propagator of the establishment, are of most excellent quality, we can testify from personal knowledge.

FRUITLAND NURSERIES.—P. J. Berckmans, Augusta, Ga., has in his catalogue all the fruit and ornamental trees and shrubs that succeed in the warmer states. It of course includes many kinds the names of which are unfamiliar to the northern cultivator, but which experience has shown to be most valuable to the Southern planter. We never saw finer stock than that in these nurseries.

T. S. HUBBARD, Fredonia, N. Y., send a wholesale list, in which the leading varieties of grape vines and fruit trees are offered to planters and dealers at low rates.

GEORGETOWN (Del.) NURSERIES.—R. S. Johnston offers the usual assortment. Peach trees a specialty, and at very low rates.

STORRS, HARRISON & Co., Painesville, O., make a specialty of the American chestnut trees and seed; they offer, besides, other forest trees in large quantities.

MOUNT HOPE NURSERIES.—Ellwanger & Barry, Rochester, N. Y., have one of the largest nurseries in the world. Their various catalogues, including hardy and greenhouse stock of all kinds, when bound together, form an attractive volume, which comprises about everything that is worth growing in the lines of fruits, ornamental trees, or greenhouse and bedding plants.

RANDOLPH PETERS, Wilmington, Del., is the proprietor of the "Great Northern and Southern Garden and Nursery." While he gives special attention to the peach and pear, he offers a general assortment. In a visit to this nursery two years ago, we found the peach stock remarkably thrifty and handsome, and the pear orchard probably not to be excelled this side of California for productiveness and fine fruit.

F. J. KINNEY, Tatnuck, Worcester, Mass., sends a so-

lect list of small fruits, including grapes. The catalogue is judiciously small, but contains all the really valuable and well tested sorts.

GREENHOUSE AND BEDDING PLANTS.

F. K. PHOENIX, Bloomington, Ill., does not confine himself to the nursery, but is largely in the plant business. His new catalogue of this department contains several novelties that we have not seen elsewhere.

STORRS, HARRISON & Co. send out a neat illustrated catalogue, in which they offer new and old greenhouse and bedding plants and roses in great variety.

PETER HENDERSON, 35 Cortlandt street, N. Y., sends the twenty-sixth annual catalogue of his extensive greenhouses at Jersey City Heights, N. J. The novelties as well as the standard varieties are illustrated by numerous wood engravings, and the catalogue embellished by two large, fine colored plates—one of Verbenas and the other of Fuchsias.

BELLEVUE NURSERY Co., Paterson, N. J., H. E. Chitty, Supt., send a combined plant and seed catalogue. Though a comparatively new establishment, this shows commendable enterprise in offering new plants as early as the earliest; and we have had frequent occasion during the past year to speak of the fine and rare plants sent out by them.

LIVE STOCK.

CLAUDE MATTHEWS, Clinton, Indiana, issues a catalogue of the "Hazel Bluff" herd of Shorthorn cattle, which is handsomely illustrated with portraits of choice animals.

F. J. KINNEY, Worcester, Mass.—Brown Leghorn fowls.

IMPLEMENTS.

THE BUCKEYE MOWER AND REAPER.—Accompanying their price-circular, Messrs. Adriance, Platt & Co., send out some illustrations of their machines on the road and in action which are remarkably fine and spirited.

THE HIGGANUM MFG Co., Higganum, Ct., publish a catalogue of their plows and other farm implements in the form of "The New Almanac," in which useful information and advertising are judiciously combined. The publishers have had the good sense to take a portion of their "agricultural clippings" from the *American Agriculturist*, and what is more, to acknowledge their indebtedness.

Patents.

We presume that there are but very few of our readers who are not interested one way or another in patents. In fact, there is hardly an article of every-day use, whether it be an expensive personal ornament or the homeliest household implement, but bears the magic adjective "patented." As there are very few persons who understand our patent system, we state in brief its fundamental principles.

The public say to the inventor—You have a valuable secret which may benefit us. To disclose it without protection would be to lose it. To keep it would deprive us of its use. If you will disclose it to us by so describing and illustrating that we may fully understand it, and may avail ourselves of it without difficulty, we will agree that for seventeen years you shall be protected in its use; you may make out of it what you can. When your limit of time has expired we shall have it without further payment. We can not pay you in money, we will pay you in time. This is a fair bargain. A new thought developed, explained, described, illustrated, put on record for the use of the nation—on the one side. The right to the exclusive benefit of this new thought for a limited time and protection in that right—on the other. This is the patent system; a fair contract between the public and the inventor under this system. The inventor's best and only security is to take out a patent that shall fully and carefully describe and show his invention in proper form, and of sufficient scope to protect him in the exclusive use of his invention during the seventeen years that the patent is granted. It is safe to say that a very large proportion of all the patents granted are for inventions of real value, and that the inventors would reap handsome rewards for them, if they displayed as much business tact as they do inventive genius. Here is the reason so many patented inventions fail to bring the reward hoped for by the inventor. The invention is valuable enough, and the public will appreciate it if you put it before them in the right way, but it is this *putting before the public*, in other words, the management of the business growing out of the invention, that causes the disappointment in so many instances. If the inventor locks his patent up in his bureau-drawer, and expects it will make him wealthy without further effort, he does not have to live very long before he discovers his mistake. We therefore advise our friends who patent valuable inventions to conduct the business

growing out of their patent in a judicious manner, and they will be rewarded. In response to the frequent inquiries of our friends we have established, in connection with the *Agriculturist*, a Patent Department through which inventors may patent their inventions, and have all their business concerning patents promptly, faithfully, and ably attended to, with the additional assurance that their business will be conducted honestly and at reasonable rates. A pamphlet giving full particulars may be had on application.

Hardened Sweet-Potato Plants.

BY J. B. ROOT, ROCKFORD, ILL.

Since the cultivation of sweet-potatoes has been found to be so easy, and has become so general even in the northernmost States, the demand for "slips" or plants has been so large as to make their growth an important business. But during the past few years a strong and a well-founded prejudice has arisen against Northern-grown potatoes, because when cooked they are more watery and less sweet than those from the South, and moreover do not yield nearly as largely.

This, it is generally believed, is because our seasons are not warm enough to fully mature the roots. This is certainly a mistake, for during our warm weather the temperature is quite as high as that of the South, but it is not so long continued, and it therefore behooves us to put our plants in that condition that they can derive benefit from all the heat we do have, and shall be in excellent working order from the first day of sufficient temperature for them. For several seasons I have sought this condition by bedding my potatoes at least three weeks before the usual time in this latitude, say by the 20th of March, and then bringing them forward as rapidly as possible until ready to pull. They are then transplanted or "heeled in" about three or less to the inch in rows four inches or more apart in a mild bed. Here they quickly begin the process usually undergone in the open ground a month later—throw out their secondary or true roots and become independent plants, drawing sustenance from the soil instead of the mother potato. It is while undergoing this radical change that so many die, and the others are so put back as to not make any perceptible growth for two or three weeks. This change is much more quickly made in the certain and even temperature of the hot-bed than in the open air with its sudden changes and often its long cold rains. Moreover, aside from the quickness and safety with which the plant strikes true roots, it is already three weeks ahead of the general crop.

In this second bed, if the vines grow too rampant before the open ground is ready for them, shear off the runners and draw a knife between the rows to root prune, as recommended for tomatoes. This induces the growth of a new mass of roots, and doubly insures the life and thrift of the plant when put in the field. After they are well rooted in the second bed, give them all the exposure they will stand without injury, and harden them so they can be set in the open field as soon as danger of frost is past. But few are lost when transplanted into ridges, and they quickly cover the ground with vines, and not only yield more and larger potatoes, but vastly better ones. I think I have eaten as sweet and dry potatoes of my own growing as any we receive from the South.

This method, of course, entails considerable labor, and in growing the plants for sale the experiment should not be entered upon largely the first season, for buyers rarely feel willing to pay the increased price for any quantity of the plants until they have given them a year's trial. But in raising plants for home use you certainly will not regret treating a good many in this way.

Forest Trees from Seed.

Tree planting has become in some parts of the country a subject of great importance. Trees for timber, fuel, shade, and shelter are needed in all prairie countries, and while we appreciate the great necessity for tree planting, and would urge every one, East or West, to consider whether timber is not the best crop he can put upon parts of his land, we have not had so much to say about raising trees from seed as perhaps our friends think they have a right to expect. We would not lead our readers into experiments that if not expensive are likely to be fruitless. How many persons opening up a new farm on the prairie can find time to take proper care of a vegetable or a flower garden? Yet the raising of trees from seed demands as much or more care than do vegetables or flowers, and our hardy white pine and other evergreens require in their early years much greater attention than a delicate flower. Premising that we advise no one to undertake to grow trees from seed unless he is quite able to give them as much care as the same number of let-

tuces or cabbages, we give a few condensed notes which will answer many inquiries.

EVERGREENS we can not advise the ordinary farmer to undertake to raise from seed; they require so much care in shading and otherwise, and small plants are sold by those who make a business of growing them at such low rates, that we are sure that 99 in 100 will find it much more satisfactory in the end to purchase. We therefore confine our remarks to deciduous trees.

TREE SEEDS THAT MUST BE SOWN AS SOON AS RIPE.—Soft or Red and Silver Maple, Elm, and Red Birch. If kept exposed even for a few days after they are gathered their vitality will be destroyed. These seeds are not generally kept by seedsmen, though some take orders in advance to be filled when the seeds ripen. Those who wish to sow seeds of these should arrange beforehand with some friend to gather them, or dealer to supply them, and be prepared to sow the day they are received. The plants come up at once, and make nice young trees by fall.

TREE SEEDS TO BE SOWN IN PLACE—that is, the seed is to be sown where the tree is to stand—include the different Hickories, the Bntternut, and Black Walnut. The seeds are collected in fall, made into heaps, and covered with sods, over which are thrown several inches of earth. In the spring the nuts are sown in place, putting in two or three near together, and if all start remove all but one.

TREES THAT MUST BE TRANSPLANTED WHEN SMALL.—The Chestnut, Beech, and Oaks of all kinds are to be sown in a seed-bed and transplanted the first or second autumn. The nuts are to be kept during winter, mixed with at least an equal bulk of sand, in a cool place where they will not get too dry.

SEEDS OF TREES THAT MAY BE SOWN IN FALL.—Ash of various species, Liquidambar, Tulip-tree, Cucumber, and other Magnolias. These may also be sown in spring if properly kept through the winter in sand.

SEEDS BETTER SOWN IN SPRING, but they should be carefully kept through the winter in sand.—Maples of all kinds, including the Ash-leaf or Box Elder, and excepting the Silver and Soft; Birches, except the Red; Bass-wood; Kentucky Coffee-tree; Ailanthus; Catalpa; Paulownia.

SEEDS NEEDING PREPARATION before sowing in spring.—Osage Orange, scald and keep warm and moist until it sprouts; Button-ball, soak; Honey Locust and Common or Black Locust, scald.

TREES GROWN FROM CUTTINGS.—All Willows and Poplars from branches an inch and less in diameter; Ailanthus and Paulownia from cuttings of the root.

Seedling trees require just as careful thinning and weeding as a crop of carrots. If they suffer from the heat of the sun, stick brush with the leaves on all over the bed sufficiently thick to give a proper shade, or use a screen of lathes.

The leading tree seeds are kept by most seedsmen. Those who make a speciality of them, and keep a full assortment are: J. M. Thorburn & Co., New York; Thomas Meehan, Germantown, Pa.; and Arthur Bryant, Jr., Princeton, Ill.

Bees Notes.—Advice to Beginners.

BY M. QUINBY.

The location of the apiary should be attended to early this month. I do not mean by this that when bees are comfortably housed they shall be put out, unless warm weather makes it advisable. But choose the location now, and get things ready. If there is nothing to break off the wind, particularly from the north-west, put up a close, high board fence—if ten feet high all the better. Have the location warm. Allow the sun to strike the hives as nearly all day as possible until hot weather. If the soil is not very moist set them within two or four inches of the ground on blocks or bricks. If wet have them a little higher. Whatever the distance may be, have an alighting board reaching from the ground to the entrance, one edge resting on the ground, the other on the upper side of the bottom-board, so that if a bee alights anywhere within a foot of the entrance it can creep into the hive without again taking wing or losing time searching for it. Conceive something to enlarge or diminish the size of the entrance according to the number of bees at work during the spring months. Unless robbing bees are around, allow them to pass to and fro freely. Tin slides running in tin grooves are very convenient to graduate the entrance. During spring let all openings, however small, in the upper part of the hive be closed, to prevent the escape of the warm air. Bees the first time they leave the hive mark the locality, and if that is to be changed let it be done at once, unless they are to be moved a mile or more away, so that no time or

bees be lost by doing it later. If they are to be moved over a rough road a sleigh is best, a spring wagon next best. If moved by rail, the greatest danger is in setting the hives down harshly. To prevent breaking the combs, put staves of an old flour-barrel under the bottom for springs; screw these fast on the center of the bottom of hive, the ends bending downward, so that the weight of hive will rest upon them. Two or three are enough. Mark plainly: "This side up; handle with care." Express hands usually have a little interest of their own, inducing them to work with caution when handling a hive of bees.

If bees are comfortably housed, and remain quiet, do not be in a hurry to get them out before they can get something from flowers. Whenever they are disturbed in being set out, or in any other way, they are apt to fill themselves with honey. It has recently been ascertained that the liquid portion of this honey will pass off in the form of vapor, or insensible perspiration, if the bees are kept surrounded by a warm atmosphere. If too cool it creates a sort of dysentery, accompanied by a discharge which soils everything it touches. That the excrementitious portion of this food is discharged in a dry state in winter when the bees are healthy is proved by testing the substance that falls on the bottom-board under the bees. To do so, get some of it; half fill an ounce phial or other glass vessel and put in some clean water, and then put the vessel containing it in a dish of cool water; set it on the stove and bring to the boiling point. The little scales of wax which are mixed with it rise to the top. The excrementitious portion settles a little, and may be seen directly under the wax. Some of it may settle to the bottom soon, especially if entirely free from wax. Bees can and have been comfortably housed for six or seven months, and come out clean and healthy, and discharge as little in a liquid state as those that have been confined only a fortnight; a fact which is explained by the supposition that their excrement is passed in a dry state. The little liquid that a healthy bee does discharge when first set out is probably owing to the change of temperature it is subjected to at the time.

Another thing: It has been found that bees comfortably housed consume less food than those out doors. Bees that are outside fly out every moderate day. We have all seen something of the quantity of excrement discharged, particularly on snow. We can easily imagine that if all these drops of liquid had been properly digested and assimilated it would have lasted for months. Hence the necessity of housing or keeping warm for that reason if no other. We have a stock that has been in the open air all winter to the present time, January 31st, and it has consumed only one pound and a half in January. Another that was in the house consumed one pound and three fourths. One year ago at least three or four pounds would have been consumed, owing to the weather. Forty years ago Mr. Weeks, one of the first American writers on bees, stated in the Albany Cultivator that two or more swarms could be united and wintered in one hive and not consume any more honey than one single swarm would alone. This seemed so unreasonable that I could not avoid trying the experiment by uniting several. In some hives I put two and in some three stocks. I weighed them October 1st and April 1st. They were housed, and in box-hives. Several single ones consumed exactly what the trebled ones did; double ones did the same. Only one of the trebled ones exceeded any of the others, and that by only three pounds. Why many bees eat no more than a few I believe has never been explained. But if we take the temperature into account as affecting the digestion it will throw some light on the subject. We all know that a single bee is easily frozen, and is quicker chilled than a cluster of them, and a small cluster sooner than a large one. Three swarms together in a hive will create more heat than a single one. In a large swarm all the honey is consumed and assimilated because of sufficient warmth. In small numbers quantities of food are discharged and wasted because the bees are not warm enough. Keep the hive warm all the season.

Ogden Farm Papers.—No. 49.

We have not kept the record of our dairy business with the minuteness with which it would be done on an experimental or "model" farm, but such figures as we are able to adduce from the accounts of 1873 may have some value as an item in the statistics of butter-making, which are gradually developing in the agricultural press.

The following record of milk produced begins on January 5th (the first Sunday), 1873, and ends on January 3d (the first Saturday), 1874. The regular Jersey herd consisted of

the following animals, of the ages and conditions stated:

Table with columns: Name, Age, Condition. Lists various cows like Rene 2d, Romp, Flora, Renella, Margery, Omo, Xyrida, Fantita, Mirth, Nora, Goldstraw 2d, Flora Hinman, Rhoda, Calliope, Flora Ogden, Rene Ogden, Fantine, Pet Margery, Evangeline, Noreina, Oonan, Audrey, Enid, Elaine, Anna Roxbury, Thrift, Daisy, Luck Lass, Virgie, Belle Ogden with their respective ages and conditions.

In addition to these there were two Jersey cows in the herd for a few weeks who gave together 477 lbs. of milk.

Also, nine grades and natives, which were milked an average of 19½ weeks.

The Jerseys named above appear and disappear on the milking list, as shown in the following table. Some had been dry for some time, owing to accidental causes, and some came in with their first calves:

Table with columns: Name, Date of birth, Date of calving, Age at calving, Date of first calving, Remarks. Lists cows like Rene 2d, Romp, Flora, Renella, Margery, Omo, Xyrida, Fantita, Mirth, Nora, Goldstraw 2d, Flora Hinman, Rhoda, Calliope, Flora Ogden, Rene Ogden, Fantine, Pet Margery, Evangeline, Noreina, Oonan, Audrey, Elaine, Anna Roxbury, Thrift, Daisy, Luck Lass, Virgie, Belle Ogden with their respective dates and remarks.

* Aborted. Six of the milking animals were sent to our sale depot in Illinois, November 21st.

It will be seen from this list that of the 30 Jerseys 6 were 3-year old heifers with second calves, and 7 were 2-year olds with first calves. Nine abortions, falling largely among the better animals, seriously diminished the yield.

The product of milk for the year was 103,180 pounds. Of this the nine grades and natives gave 15,041 pounds and the odd two Jerseys 447 pounds, leaving 87,692 pounds for the Jerseys. Counting the whole thirty as cows,

and as being in the herd for the whole year, the product would be 2,923 pounds each. But it was far from being a herd of thirty cows. Of Renella, Margery, and Thrift, we had only the fag end of their unfavorable milking of the previous year. They were entirely absent eight, nine, and seven months, equal to an absence of 2 cows for 1 year. Those sent to Illinois being deducted equal an absence of 1 cow 1 year. The 7 two-year old heifers and the 9 aborting animals would be liberally treated if we were to count them as equal to half as many cows, or deduct 8 for them for the whole year.

These deductions will bring the herd of the year to nineteen average cows, yielding an average of 4,615 pounds, or—calling $2\frac{16}{100}$ pounds a quart—to an average of 2,146 quarts.

The foregoing is of course only an estimate, but it is an estimate based on a carefully kept record. Knowing the character of each animal, I think I have overstated none of the deductions, and that it is well within the limit of fairness to rate the herd of Jerseys for the year at nineteen cows. If our first object were to make a large product of milk and butter, the yield would have been considerably greater than it was, for there are a number of animals which would be discarded to make room for larger milkers. For instance, Flora has lost one quarter of her udder, and others have, for various reasons, fallen off in milking value. Our main purpose is to breed Jerseys for sale; Flora and the others spoken of are naturally excellent, and they bring calves of first rate quality. Therefore they are kept and are profitable. If a cow is a good breeder and brings valuable calves it pays us to retain her whether she is now a large milker or not. Then, too, we feed for breeding, not for milk, and for good milking condition, not for fat. Probably our product of butter could have been increased from one fourth to one third by the liberal use of corn-meal, but this would have given the cows, and probably their calves, a tendency to take on fat, which is exactly what is not wanted in a butter-making animal; would have increased the danger of milk-fever and the risk at calving time; and would, if continued, probably have sent the whole breed to the shambles earlier than the less stimulating food they get, which consists (in addition to their hay and green fodder) almost entirely of wheat bran. Some years we have roots, but this time the drouth prevented.

How much the severe and long-continued drouth affected the year's yield it would be idle to guess, and there is no use in a farmer imagining what would have been if—and if, and if. Every year is full of "ifs," and they may as well be disregarded first as last. The foregoing is an exact statement of what happened at Ogden Farm in 1873. I wish it had been ever so much better, and it should have been better, but I have set forth all the drawbacks we can fairly claim, and the account is presented without complaint. We have the satisfaction of knowing that it is better than the average.

While it is not our *first* object to make a large product of butter, this is a very important object, and we do make all we can. During the past year we have bought milk from near neighbors, and this year we propose to buy from others a little farther away. In time we may extend to all who care to sell to us, who are near enough for their milk to be brought without too much jolting. We pay

four cents per quart delivered at the milk house. What we have bought this year has made (by frequent experiment) just about one pound for each twelve quarts, averaging the different seasons. If we get 48 cents for the butter we have the skimmed milk for profit. In 1873 we bought 15,422 quarts, which, by the above calculation, made 1,285 pounds of butter. Much of this was sold for 50 cents per pound, not much for less, and some of it being worked in (in the churn) with our own cream for \$1.

The whole amount of butter made, including what was consumed on the farm, during the year was 5,912 pounds. Deducting for the purchased milk 1,285 pounds, leaves 4,627 pounds for our own herd. Of this, taking out for the 15,494 pounds of milk (of the nine natives and odd two Jerseys) equal to 7,206 quarts, yielding, at 12 quarts to the pound, 600 pounds of butter, 4,027 pounds is to be credited to the regular list given above. Dividing this by 19, we have a yearly average of 212 pounds per cow.

Aside from what was consumed on the farm we sold butter for cash to the amount of \$4,472.85 over all expenses. The purchased milk cost \$616.86, leaving as a net income \$3,855.99. The proportion of this due to the natives and odd cows is \$574.52, leaving \$3,282.47 for the regular herd. This divided by 19 gives an average income of \$172.76 per cow. In making up this account we have deducted \$269.02, 124 cents per pound on 2,153 pounds of butter sold in Boston—this being paid for freight and commission; including this, the sales amounted to \$4,741.87.

We have had no difficulty in keeping up the price to one dollar per pound with all our regular customers, of whom we have all we can supply with certainty, and could probably advance it without losing many of them. The irregular surplus has been sold mainly for 50 cents per pound, but if there were more of it it could be placed at a higher price. We have one advantage in being near a place of summer resort, giving us a market at full rates for all we can make at that season, thus avoiding the necessity of bringing most of our cows in in the autumn, as we should have to do if we depended on a city market.

Do you ask how such prices are to be got? I answer, by making a really good article (which comparatively few people in American cities ever see), by putting it in the consumers' hands in the most attractive form possible, and by teaching them to depend on it by always giving them a supply and never having any irregularity in the quality. Give them this and your butter will become a necessity to them, they will no more return to the ordinary "first quality" of firkin butter than you would yourself; they will go without butter first, and so would you. This involves the necessity of educating your public, but it is remarkable how readily and quickly they take the instruction. The palate, of course, has most to do with the matter, but the eye is an important organ to be considered. A friend writing from Boston, speaking of our butter as the best she has ever seen, says: "I don't know how your dairy woman looks, but I am sure she must be an artist in her way, to send forth such beautiful looking pats, so perfectly stamped and so neatly done up. It is the most inviting looking butter we ever saw. The color is perfect and so

is the consistency. It quite spoils us for what we were eating before, though at the time we thought that excellent." When people get into this frame of mind they can be depended on for permanent custom at high prices.

Of course many a farmer will lay our success (in the matter of price) to our situation, and so be inclined not to take a suggestion from the example. But every one who makes butter to sell makes it for a market, and in every market the best butter commands the best price. If *all* were first rate, high prices would be unknown, but the fact is that there is very little first rate butter to be bought anywhere, and there is a fair field open in every town in the country for an improvement. Of course it is only near wealthy communities that really extravagant prices can be obtained, but it should be borne in mind that the extra price is *all profit*, and if it is only 15 cents, or 10 cents, or even 5 cents, it adds so much to the *net* income of the dairy.

It would surely be safe to predict that the number of people in America who would gladly pay for their table butter fifty per cent more than the regular price of their markets, will increase quite as fast as they can be supplied with a *first rate* article. In Philadelphia the whole class of well-to-do people (not rich people only), pay for their butter much more than the highest market price of New York. Away from home they eat no butter, not being able to get anything to compare with that made in the counties near them and brought in fresh every week. The more fastidious of them are supplied by specially good makers, and pay from 90 cents to \$1.10 per pound. When they go to the sea-shore or to the mountains in summer they add the considerable cost of having it brought to them by express, packed in ice. This well-fed community has learned by experience what good butter is; they economize in other things if necessary, but they must have their accustomed good butter or none at all. In every city, town, and village in the land there are plenty of people who can be easily brought to the same way of thinking. It rests only with those who supply them to teach them the way to go.

It is reported that at a meeting of the American Dairymen's Association, a prominent member said: "Butter-making is a fixed science. Everybody knows all about it; it is of no use to bring it up here." I have no doubt that this opinion is widely shared by the farmers of the country, and especially by their wives. It is true they know how to skim a pan of milk, how to work the dasher of a churn, how to squeeze out half the buttermilk with a wooden spoon, how to shovel in the salt, and how to stow it away in streaks in a firkin. Judging from the butter one sees (and smells) in the markets, a majority of them consider this the whole of the "fixed science." Those who know more about it know very much less, and there is not a single item of the process from the selection of the cow to the packing for market on which they do not crave more light and need more. We are, after all these centuries, on the very eve of knowledge, and those who first confess their ignorance and make the earliest attempts to learn are those to whom success and pecuniary reward will first come.

The royal road to good butter-making is not yet plain, but I believe that those who use Jersey or Guernsey cows, and who set their milk in deep cans (with cool water about them) have found its beginning.

The Blue-Gum Tree.—(*Eucalyptus globulus*.)

BY AL FRESKO.

Almost every newspaper or journal, American or foreign, that I pick up contains an article on the Eucalyptus or Blue-gum tree, lauding it to the skies for its powers of destroying malaria and preventing fevers. The other day I noticed an editorial suggestion in a leading New York paper to the effect that the tree should be extensively planted in the marshy regions in the neighborhood of the city so that malarial diseases might be entirely eradicated. As your journal spreads its influence over many lands, I have deemed it advisable to refer to this tree, in order to prevent disappointment. My experience is based upon a twelve years' residence in the home of the Eucalyptus, antipodean Australia. I am not prepared to give a definite opinion regarding the powers of this tree to annihilate the cause or causes of intermittent fevers; but think that the published statements regarding its sanitary powers should be received *cum grano salis*.

To use a horticultural expression, this tree is "tender," and will be seriously injured, if not entirely destroyed, by a cold ten degrees below freezing. When I left Australia, in 1865, I took with me some seed of this tree; and in 1868 presented a portion of it to an enthusiastic horticulturist of St. Augustine, Florida. The seed vegetated, and during the course of the ensuing summer made a healthy and vigorous growth. The succeeding winter at St. Augustine was marked for a low temperature, and the young wood of the orange trees was injured by the frost. I visited Florida in the July after the "cold spell," and upon inquiry found that the young Eucalyptus trees had been destroyed. It is to be hoped that no one in northern localities where intermittent fevers prevail will attempt the cultivation of this tree, for if they try the experiment they will shake twice instead of once—firstly from a chill and secondly from disappointment. Where the climate will admit of its cultivation (that is to say, where ice does not form over one-eighth of an inch in thickness) the tree is worthy of attention. When I speak of its value I do not base my estimate upon its worth as a sanitary agent, but refer to it as the most rapid-growing tree in existence, its desirability as a shade tree, its adaptability to almost any soil or situation, and its great value as a protector or wind-break in exposed situations. As an evidence of its rapidity of growth under favorable climatic conditions I will cite one case: About the year 1864 my friend Mr. Thos. Lamb, of Ballarat, Australia, read to me a portion of a letter received from Mr. McNabb, the

intelligent curator of the Botanic Garden of Natal, South Africa, in which the writer referred to the surprising growth made by the tree in that climate. He stated that he had measured a specimen that had been transplanted from a pot six years before, and that its height was 67 feet, and the diameter of the

any of the Atlantic States. It has been tried by skillful cultivators in Georgia and South Carolina, but with no better results than the trial in Florida quoted by our correspondent. It is singular that the influence of this tree to destroy malaria should not have been suspected in Australia; the story probably arose from the fact that a tincture of the leaves has been found useful in intermittent fevers.—[Ed.]

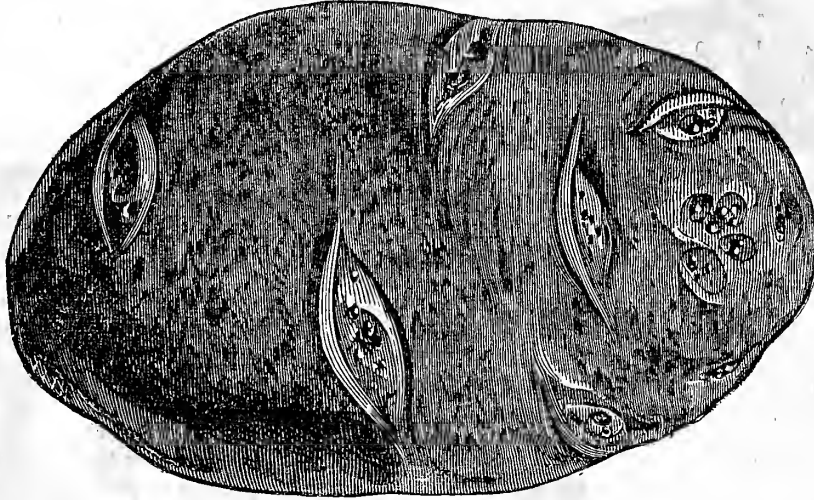

SNOWFLAKE.

trunk at one foot from the ground 17 inches. This specimen, grown in a warm, moist climate somewhat resembling that of the more favored portions of Florida, had made an annual growth of about eleven feet.

If planted as a specimen tree, the gum is symmetrical in its habit, branching from the ground, and assuming the form of a cone. If planted as a wind-break or protecting belt, the young trees should be placed in three rows about five feet apart. So planted it forms slender stems which yield to the force of the wind and do not break. The wood is very durable, and it is contended that when used

Beauty" originated with a Vermont farmer, Mr. E. S. Brownell, who states that it was produced by crossing the white Peachblow upon the Early Rose, and was first raised by him in 1870. It is properly called "Beauty," as it is, we think, the handsomest potato in appearance of any we have seen, it being remarkably fair and smooth and the skin of a fine reddish color. Great earliness is not claimed for this variety, it giving potatoes fit for the table about a week later than the Early Rose. We have not grown this variety, but have had two trials of it upon the table, and can testify to its excellent quality there. Mr. Brownell states that it has been

healthy in both tuber and vine; that it is a good cropper with but few small tubers; and that the potatoes grow compactly in the hill. This variety was sent last spring to England, with other varieties, to Dr. Masters, editor of the *Gardeners' Chronicle*, who sent specimens under numbers to the potato trial at the gardens of the Royal Horticultural Society at Chiswick. When the award was made last fall the number corresponding to Brownell's Beauty received a first-class certificate. The Snowflake is of medium size, very uniform in shape, white with a russet tinge, and has very few eyes. The engraving will give an idea of the size and form, and the writer of "Notes from the Pines" testifies to

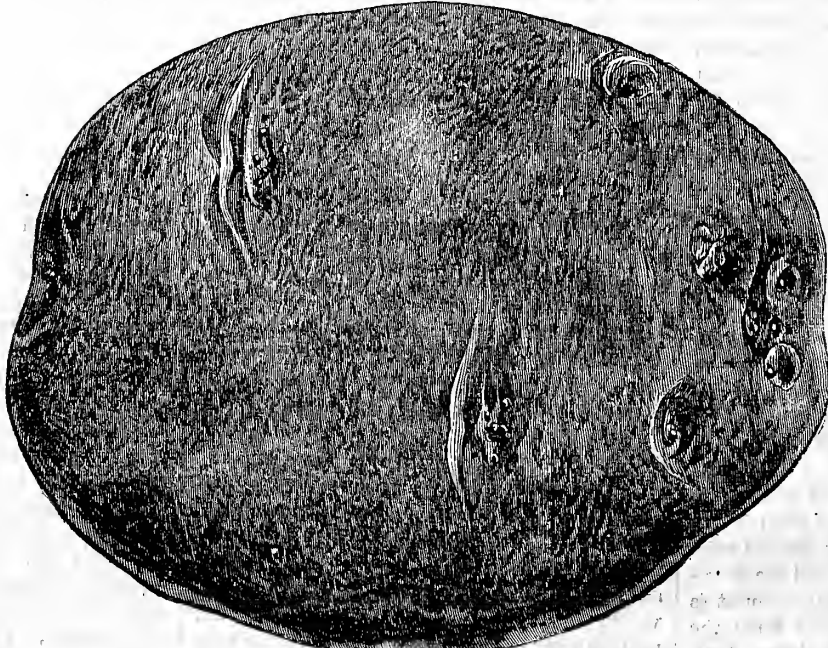

BROWNELL'S BEAUTY

in ship-building it will last as long as teak.

[We entirely indorse our correspondent's views in regard to the Eucalyptus. The daily papers, with their usual disregard of accuracy in such matters, have made so much talk about the tree that already there are inquiries for seed, and probably some sharper may take advantage of the excitement and offer to supply the demand. The tree grows finely in California, but we have not heard of its success in

its quality on page 102. Among the newer kinds that have been especially successful in England as well as in this country, is that variety of the Early Rose called Thorburn's Late Rose, which has been highly commended for both quality and yield. "Excelsior" is an American variety that has acquired a greater reputation abroad than it has here, and the same may be said of the Climax, which stands very high in England, though little grown here.

Two New Potatoes.

Yes! two more new potatoes! And why not? It would be strange if among the hundreds of seedlings that have been raised within the past few years there were not some few that possessed qualities that entitled them to be generally cultivated. There are at least two new ones offered this year that are worthy of notice, "Brownell's Beauty" and "Snowflake," both of which are introduced by B. K. Bliss & Sons. "Brownell's

The Shetland Pony.

The pair of Shetland ponies whose portraits we here give is part of a herd which was recently imported from the Shetland Islands by Mr. John G. Correy, of Suisun City, California.

These islands are a small, rocky group, situated north of Scotland in the stormy North Atlantic Ocean. The fierce north winds sweep over them carrying the spray from the waves which wash their precipitous shores. As may be expected, therefore, the herbage of these islands is scant and coarse, although sweet and nutritious. These diminutive horses, never more than forty inches in height, and which feed in a semi-wild state upon these exposed, bleak pastures,

are fitted by nature for their peculiarly hard life, and possess exceedingly tough constitutions, a good deal of endurance and spirit, and are very docile. Formerly these animals possessed but little value, and were in very moderate demand as pets for children. But some years since the English Parliament prohibited the labor of women and children in coal-mines, and these small, hardy creatures were substituted, and used to draw the cars of coal along the narrow, low-roofed, dark underground passages.

Their value immediately increased, and their breeding became an established business. A largely increasing demand for them now exists, both for this special purpose and for the use of children. Their extreme docility and diminutive beauty expressly fit them to be children's pets. The animals pictured above were prize-takers at the last exhibition at Lerwick, the chief town of the Shetland Islands, and the stallion is the winner of several first prizes. It is very probable that these hardy animals may find a place in the mines of the far West similar to that which they fill in the Welsh coal mines; but if not, there is already a large demand for them in this country for children's use, and they will certainly find a congenial home upon the hills

of California. We understand that Mr. Correy was successful in getting his herd of over 30 animals home from their long journey of nearly 7,000 miles with a loss of only two, and that his enterprise has been rewarded with the profitable disposal of nearly the whole of them.

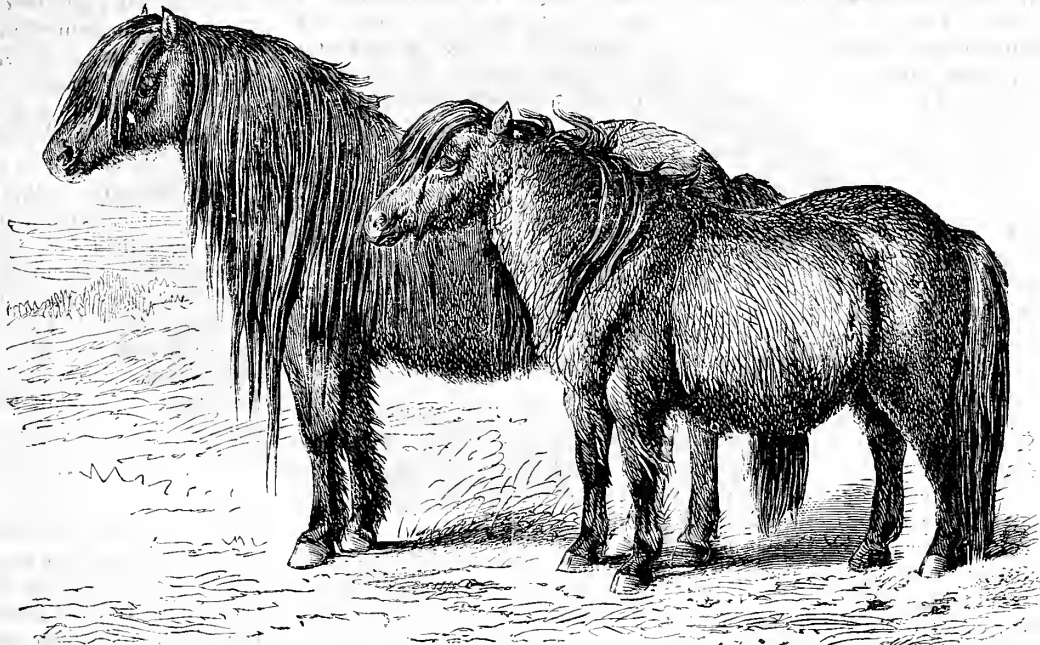

PAIR OF IMPORTED SHETLAND PONIES.

This fact shows to a great extent the extreme hardiness of these animals under exposure.

Ayrshire Cow—"Old Creamer."

The portrait of Old Creamer is taken from a photograph for which we are indebted to her owner, S. D. Hungerford, of Adams, Jefferson Co., N. Y. This cow was exhibited at the New York State Fair in 1873, where she took the

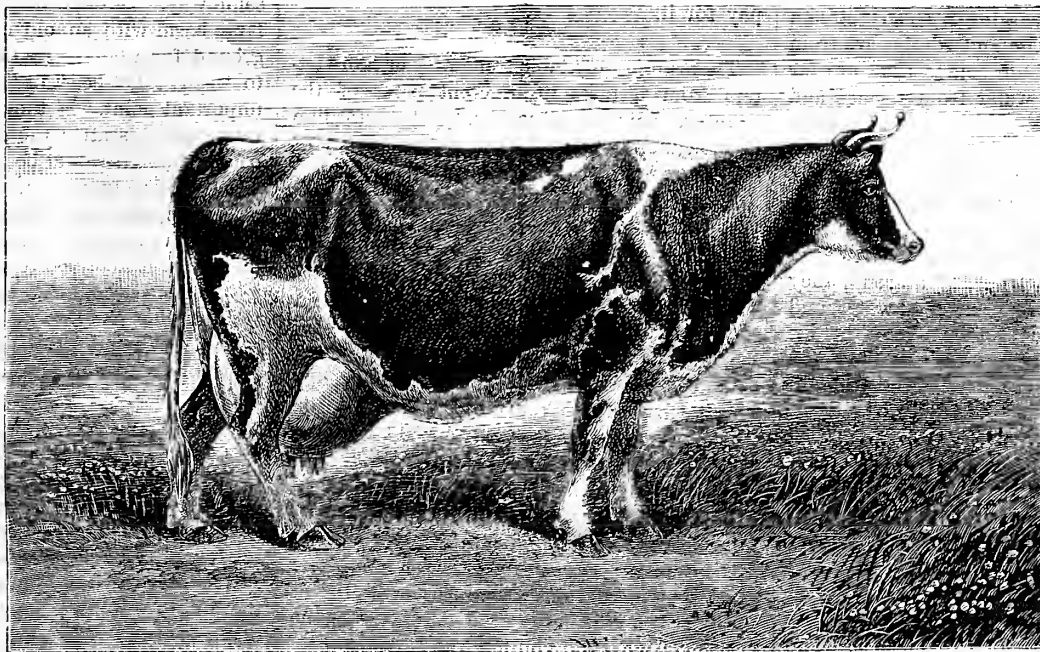

AYRSHIRE COW—"OLD CREAMER."

first prize as the best milk cow of any breed. She is an Ayrshire, nine years old, weighs 1,080 pounds, and is claimed to be the champion cow of the world. This is an extensive claim, but would seem to have some foundation when we learn that this cow in three days in June last gave 302 lbs. of milk, or 135 quarts—an average

of 45 quarts a day. Her average for the whole month of June was over 94 lbs. per day, for July 80 lbs., and for August 74 lbs. In eleven days in June she gave more than her own weight of milk. The performance of this cow, as well as that of Beacon Belle, another Ayr-

shire, whose portrait was engraved in the *Agriculturist* of November, 1873, shows in a very striking manner the value of the Ayrshires for the dairy. This breed having been subjected for many years past to very careful training and selection for that express purpose, is now without a rival for quantity of milk, while for excellence of quality it has but two superiors—viz., the Jersey with the Guernsey, and the Devon, these, however, being less productive in quantity. For the

cheese dairy this breed is the most profitable, and a singular fact recently made known by Dr. E. L. Sturtevant of Massachusetts goes to add much to its value. This fact, which has become known through much careful investigation by Dr. Sturtevant, is that the milk of the Ayrshire cow contains its cream in very small globules, which are separated from the milk only with extreme slowness and difficulty. In making cheese from Ayrshire milk, therefore, the cream remains in

the curd, adding much to its richness, and is not lost in the whey. The skimmed milk of the Ayrshire cow is therefore of equal value for cheese-making with the whole milk of cows of other breeds, the cream from which rises and separates very readily and rapidly. The cream from Jersey milk exists in large globules, which separate very quickly and completely from the milk, leaving a blue, poor liquid, quite unfit for the making of cheese. Jersey milk is

therefore only adapted for butter-making, while Ayrshire milk is well adapted for either whole cheese manufacture or partly butter and partly cheese-making. The Ayrshire cow therefore holds a place in the dairy in which she can never suffer in competition with any cow of any other breed whatsoever.

Walks and Talks on the Farm.—No. 123.

My big underdrain works grandly. It is pleasant to see a ten-inch pipe discharging water to its full capacity. It empties into an open ditch on the side of the road. The Deacon has a shallow, open drain that runs into the same ditch. This drain of the Deacon's is the natural outlet to the drainage of seventy or eighty acres of land, and during rainy weather and spring thaws there is a great body of water running through it; so much so that it spreads over several acres, and not unfrequently gets so high as to overflow the road. My big underdrain is the natural outlet to the drainage of about twenty acres, and I have diverted into it the drainage of some thirty or forty acres more, including the Deacon's "duck pond."

Now, what I want to say is this: The Deacon's open ditch only discharges the surface water. It runs for a week or two and then stops, leaving more or less water standing on the surface of the land, and the whole soil saturated with water, which is only got rid of by evaporation. Much of the land is not dry enough to plow before May or June, and a few hot days will then bake the "clay spots" until it is impossible to get them into good tilth.

Said the Deacon when I first commenced to drain: "If everybody should drain their land as you propose the rivers could not carry off the water, and our cities would be destroyed by the floods."

I told him that underdraining would do much to prevent floods, and this big underdrain of mine is an illustration in point. The first week of last January we had a great rain. It flooded the country and saturated all the land. The water came down with a rush from the Deacon's surface drain. From my underdrained land there was no surface water; it all came through the underdrain. But mark the difference. In a week or ten days we had freezing weather, and not a drop of water came from the Deacon's surface drain; but my big underdrain kept discharging a steady stream for days and weeks. The underdrains are from 2½ to 5 feet deep, and of course they are far below the frost. The water from springs and from the subsoil continues to flow into these drains all winter, or at any rate as long as there is any excess of water in the subsoil. On the Deacon's land no water will drain off during frosty weather. The land, both on the surface and in the subsoil, will be saturated.

Next spring, when the rains descend, they will fall on this soil, already full of water, and will pass off in a rush to the streams below. On the other hand, the rain on the drained land will slowly sink into the dry subsoil and will pass off gradually.

"I have just got a letter, Deacon," I said, "that I think will please you. In the fall of 1872 I sent three bushels of our white wheat to A. L. Clark & Son, of Hampshire Co., Mass. They sowed it on 1½ acre of land that had raised three successive crops of tobacco. It was sown September 12th and cut July 21st. The yield was 5,250 lbs., or 87½ bushels. The land was accurately measured, and contained 289 rods. The yield, therefore, was 48½ bushels per acre. This is not bad for old Massachusetts."

"We exhibited the wheat," they write, "at the Hampshire, Hampden, and Franklin Counties Fair, held in Northampton, and were awarded a premium for it and also for flour made from it. We sold 12 bushels for seed at

\$4 per bushel. We are haying the wheat made into Graham flour, and selling it at \$5.50 per 100 lbs. We drew five large and one small two-horse wagon loads of sheaves from the field, and the straw is worth \$20 per ton at the barn."

That is a big story. I told Ellwanger & Barry that Massachusetts had beaten them, and they said they would try again. It won't do to have New England raise more wheat per acre than Western New York. Just figure up what this 1½ acre of wheat brought in, assuming that a bushel of wheat would give 100 lbs. of straw.

Receipts from 1½ acre of wheat:
12 bushels, sold for seed, at \$4..... \$48.00
75½ bushels, say 4,379 lbs., Graham flour..... 240.84
8,750 lbs. straw, at \$20 per ton..... 87.50
\$376.34

"That is more money," says the Deacon, "than some of us made last year from our whole farm."

There is money to be made in farming yet, if we only raise big crops. We can raise just as good wheat now and as much per acre as we ever could, provided we make the land dry, rich, and clean.

I wish our young farmers would wake up to this fact. I wish they could feel that there is as much to be learned and as much to be done in agriculture as there ever was. There is a grand field for all the intelligence, skill, science, energy, and experience they can bring to bear.

Any real improvement in an agricultural implement or machine is welcomed by thousands and tens of thousands of farmers. Good breeds of horses, cattle, sheep, pigs, and poultry are in great and increasing demand.

"But will it continue?" asked the Deacon, who seemed to be tired of this kind of talk.

Certainly it will continue. The demand will be greater and greater as the general character of our agriculture improves. The world needs more and better meat and will be willing to pay for it.

There are on my table some fifty or more letters from farmers in different parts of the country. I like to get letters, but I do not like to answer them; and I fear a great many of my correspondents are offended.

"Read a few of them," says the Deacon.

Here is one from J. G. Smith, of Montana Territory: "What will you charge me for fifty head of Cotswold ewes and two rams? Our country here is, I think, peculiarly adapted for sheep—a very dry atmosphere, with open winters and abundance of good feed. There is not over 10,000 head of sheep in the Territory, and they are driven here from Salt Lake and Oregon for the butchers, selling at from \$8 to \$12 per head. The country is overrun with horned stock, with no demand except for home consumption. Flour sells for \$4 per barrel; oats 35c., barley 50c., and wheat 40c. per bushel; dressed pigs 8c. to 10c. per pound. The trio of Essex I got from you are doing well."

"That is a very interesting letter," says the Deacon; "what did you tell him?"

I told him he had better buy some common ewes in the Territory and cross them with a well-wooled, rather small Cotswold ram, and not go so extensively into the raising of high-bred sheep. One or two crosses would make an immense improvement in the native sheep.

"Which is the best way to use the droppings from the hen-house?" asks the next letter.

"Mix them with ashes and plaster, and put them on the hills of corn is my plan," says the Deacon.

"Mine," I replied, "is to put them into the manure heap."

The next letter asks several questions in regard to the management of manure.

"I let mine stay in the yards and sheds until spring," says the Deacon, "and then draw it on to sod land and plow it under for corn. I think I make twice as much manure in proportion to the number of animals as you do."

"Yes; twice the bulk," I replied, "but not half the value. One ton of my manure is worth more than four tons of yours. Your manure consists principally of rotten straw and water—or at least this would be the case if the straw was rotten. The way I manage my manure the present winter is this: I cut up every pound of straw and stalks and hay and clover-seed straw with an eight-horse power machine. I keep 7 horses, 10 cows, 75 pigs, and 120 sheep."

"I thought you had more pigs," said the Deacon.

These are all I have wintered over. I sell my young pigs at two months old, and never sold so close as last fall. If I have good luck I shall have over 200 young pigs in the spring. The pigs are my best manure makers. The great trouble is to get bedding enough. I could make a great pile of manure if I could use straw as freely as many of our farmers do. My two principal objects are to save all the liquid and to keep the manure slowly fermenting in a heap all winter. The horse-stall is of course cleaned out twice every day, but instead of throwing the manure out of doors to be wet with rain and snow we throw it into an empty stall by the door. Here it remains until we have a load of it. We then take this dry horse manure and use it for bedding the pigs. The dry manure from the sheep sheds is used in the same way. In the center of the barn-yard is a large basin with an old oil-barrel sunk in the ground for a tank. In the fall I tell my men to "start a hot-bed" in the basin. This is an important point. If they had their own way they would scatter the manure all over the basin, where it would be exposed to the rains and be frozen in winter. When put in a compact heap, and the manure leveled down every day as it is wheeled to the heap, an active fermentation is kept up all winter. The sides and top freeze a little, but the center is a mass of steaming-hot manure. There is no loss of ammonia. We put planks from the barn doors on to the heap and wheel the manure on top and spread it. If you do not spread it at once it will freeze. It looks now as though this heap of manure would be in splendid condition for root crops next spring without turning. I propose to sow 14 acres of mangel-wurzels where I had corn last year, and shall use this manure for them. I shall spread the manure on the surface, harrow thoroughly so as to mix it with the soil, then plow it under and drill in the mangels on the flat.

"Would not the hen manure," asked the Deacon, "be good for mangels?"

Certainly it would. Nothing better. But it is a drop in the bucket. And when I put it in the manure pile not a pound of it is lost. It finds its way to the field, and I have no trouble with it. Besides, it is a capital thing to start fermentation in the manure pile or hot-bed. Depend upon it, this is the right way to use

hen manure, bone-dust, horn shavings, refuse wool, hair, blood, or any other animal or inorganic matter.

"Is it better to plow under the manure or apply it on the surface?"

Whichever is most convenient. The real point is to make rich manure and get it thoroughly decomposed without loss before putting it on the land. Then use it on some crop that will appropriate it at once. Of course, a good deal can be said in favor of manuring the soil rather than of manuring the crop. It depends on circumstances. The Deacon thinks long, strawy manure is worth more for lightening the soil and making it porous than for its plant-food. I am not sure but he is right, for it is certain that such manure as is made almost wholly from straw does not contain much plant-food.

The next letter is about petroleum. But I have told all I know about it. It is good to preserve wood. It is not good for paint. The easiest way to apply it to the shingles on a roof is to stop up the gutters. Then take the petroleum on to the top of the roof in a watering-can and sprinkle the whole roof with it two or three times. The more you can get it to absorb the better. If any of the petroleum runs into the gutter apply it with a brush to the shingles below the gutter. I use two or three barrels a year. The price varies. I have paid as high as \$10 per barrel. I have just bought two barrels of 42 gallons each for \$7 per bbl. This includes the barrels. They offer me \$1 each for the barrels. But I find them very convenient on the farm. They do not shrink in the sun. Sawn in two they make capital watering troughs.

"R. P. W." writes from Nebraska that he is in the sheep business. He keeps 300 sheep, and has only lost six in ten months. He feeds prairie hay and corn in winter. Little timothy is raised. The prairie grass gives out on the first frost, and he wants something for late fall and early spring feed. He asks about rape and mustard. The latter will not stand frost. The former will. As long as prairie hay and corn are so abundant, I should doubt if it would pay to raise either mustard or rape. I should try Kentucky blue grass and timothy. Keep the stock off of it after July, and use it as a late fall and winter run for the sheep, feeding prairie hay and corn as well. He asks if long-wooled sheep will do well in flocks of five hundred. The size of the flock has little to do with the matter. It is a question of care and food. With dry winter quarters and an unfailling supply of food and water, with a good run on dry land in winter, I see no reason why long-wooled sheep can not be kept in as large flocks as Merinos. I have Cotswold sheep, grade Cotswolds, and Merinos running in the same flock, and the Cotswolds and their grades keep fatter, grow faster, and yield more wool than the Merinos. But they are larger sheep, and of course eat much more food. They have no better food, however, than the Merinos. All run together and are fed alike. I have only half a dozen Merino ewes, which I keep to raise lambs for my own eating. They look very forlorn by the side of a two hundred and fifty pound Cotswold. Visitors often say that the Cotswolds starve the Merinos. It has usually been thought that Merinos, being more active, would starve the Cotswolds. If I lived in Nebraska I am not sure that I should keep

long-wooled sheep. The Merinos can rough it better, and where there is no demand for lambs or mutton I certainly should not keep any of the English breeds of mutton sheep.

"That is sound," says the Deacon. "We do not want the West to compete with us in raising mutton and long wool. What is your next letter?"

It is from "R. R. H.," of Rockton, Ontario. He has a field of clover, mown for hay and seed last year. It will be sown to wheat next fall. He has drawn his winter manure into the field as fast as it was made and put it in a pile. It is fermenting enough, he says, to keep the snow melted on top. The field will be pastured until June. Then turn out the cattle, and allow the clover to grow to August. Then plow under the clover, harrow, and cultivate until the beginning of September, and then drill in the wheat. "Now," he writes, "will it be better to apply the manure on the clover in the spring or rot it thoroughly through the summer and spread it on the land just before drilling in the wheat? The soil is a sandy loam."—That is a well put question. It will be better for the land in the end to apply the manure to the clover in the spring; but he will probably get more wheat if he can keep the manure over in good condition until fall, and then spread it on the furrows and harrow it in before drilling. I adopted this plan on part of my wheat last year. But I kept the manure in the basin in the yard, where I could pump the drainage water on it when necessary.

"If I had such a field," says the Deacon, "I would plow under the manure in May or June, drill in with beans, and sow wheat in the fall. You did so once, and had a good crop of beans and a big crop of wheat after them."

It is a capital plan when your land is rich.

Making Rich Manure.

Last month we gave some illustrations of a method of feeding stock in covered sheds. We now desire to show the value of the manure so made. The greatest need of our farming just now is, and in the future will be, the production of rich manure, and until every farm shall have a few feeding animals kept expressly with a view to the manufacture of manure, our agriculture will fail of securing its greatest profits. The present system of making and keeping manure is a most wasteful one. It is safe to say that at least fifty per cent of the value of manure is lost by its exposure to the weather during a whole winter, at least under ordinary circumstances.

Although we have never made exact experiments, yet having during one winter kept several head of stock in a covered shed, constantly well bedded with straw, and allowed the manure to accumulate until spring beneath the cattle, we can testify to the merits of this system of feeding under cover. The stock were kept in the best of health. They exhibited the greatest contentment. They were cared for and kept clean by carding with the least trouble of any of our stock. The manure when removed in the spring was in the finest condition and showed its value by bringing a crop of potatoes, for which it was used, equal to 450 bushels of Early Rose and 600 of Harrison potatoes per acre respectively. When, therefore, we call attention to the following experiments by a prominent English farmer, it is with perfect confidence, as we have realized somewhat of

the same results in our own experience. The experiments to which we refer were made by Lord Kinnaird, a large Scotch land-owner and farmer who has followed the practice for over 20 years of feeding his cattle in covered courts or sheds in which the manure accumulates beneath the cattle during the whole winter or feeding season. Recently Lord Kinnaird planted potatoes upon four acres of land. Two acres were manured from the covered stalls or sheds, and two with barnyard manure of the ordinary kind. The character of the soil was exactly similar upon each of the plots, and they adjoined each other. The crops were as follows: Upon one acre with covered manure the yield was 472 bushels, and upon the other acre 443 bushels. With ordinary manure from the open barnyard the yield was 272 and 297 bushels upon each acre respectively. The following year these plots were sown with wheat, and the crops were, upon the first mentioned acres 55 bushels 5 pounds and 53 bushels 47 pounds; upon the last mentioned, 41 bushels 19 pounds and 43 bushels 38 pounds respectively. The difference in yield shows the extra value of the covered manure. In our own case 14 head of young stock (two-year old heifers) were fed in a lean-to shed (40 x 12), the lumber for which cost less than \$30, and the labor in putting it up less than \$5. They were fed upon cut corn-stalks, bran, and corn-meal from October to April, and were bedded with wheat straw quite plentifully. All through a cold winter the manure never became frozen, and it made a mass of the most compact kind three feet deep, so that there were 1,440 cubic feet or over 11 cords, which if it had been as loose as ordinary barnyard manure would have measured nearly twice as much. The slow fermentation it had undergone had completely rotted the straw and reduced it to the finest condition, so that it was removed with the greatest ease. The absence of any evaporation or exposure to the weather doubtless fully doubled the value of the manure, to say nothing of the saving of labor in the making and final handling of it.

THE USE OF SALT FOR STOCK.—While a certain amount of salt is absolutely necessary for the health of stock, it by no means follows that its indiscriminate use is either needful or safe. On the contrary, salt used in excessive quantities is highly dangerous. It then acts upon the stomach and intestines as an irritant poison, and cases of death have occurred through permitting cattle and hogs to consume too much of it. When stock are allowed free access to it they will take a small quantity very often, but if denied a frequent supply they become ravenous for it, and are in danger of eating it to excess. The safest way is to use a small quantity regularly in the food; a quarter of an ounce daily being amply sufficient for a cow or a horse, and a fourth of that quantity for a hog or a sheep. If stock are salted once a week no more than one ounce at a time should be given to a cow, and a quarter of an ounce to a sheep or hog. It should also be given in such a manner that no one animal should eat more than its share. It may be given scattered thinly in the feeding trough with more safety than in any other way excepting when it is mixed with the feed. Regularity in its use is the most conducive to the health of the cattle. We find it necessary to give this caution because some of our readers have been led to suppose, very erroneously, that as salt is a good thing, stock can not have too much of it.

A Butter Dairy.

There is no article of food produced that depends for its excellence so much upon the neat-

New York. The churning is done by horse-power, and the position of the power outside of the building is seen in the engraving. The motion is given to the churns by a crank and

passes through these pipes into the milk room, filling it, and displacing the warmer air, which is forced out through the ventilators in the ceiling. In this manner the necessary regular temperature is kept in the milk room, without regard to the degree of cold or heat which may exist outside. The size of the milk room is 16 x 16 feet; it has but one window, and that upon the north side.

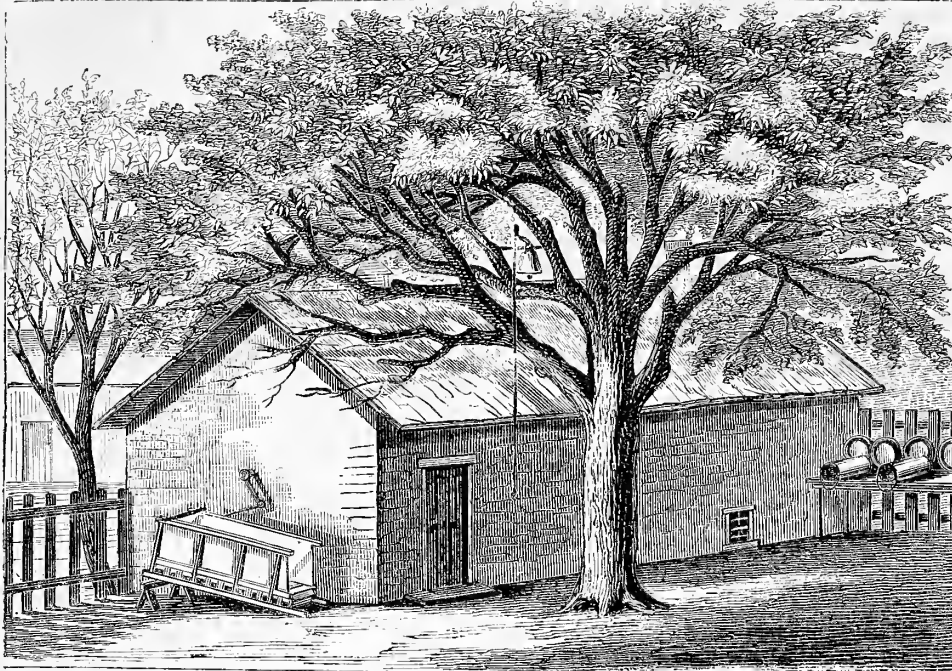

Fig. 1.—ELEVATION OF DAIRY.

ness, skillfulness, and perfect cleanliness of its manufacture as butter. We have heretofore given descriptions of a dairy managed upon the deep-can system with a cold water tank. We here give engravings with description of one managed upon the prevalent shallow-pan system, the pans used being the common tin ones holding about ten quarts.

The building should be of stone, or if of wood it should be built with at least six-inch studs, and be closely boarded with joints broken upon the studs and battened, and the inside well lathed and plastered. For thirty cows the size required would be 36 by 16 and 10 feet high, with 26 feet of it sunk four feet below the ground. In this sunken part the milk room and ice house are placed, the other portion being used for the churning room. Steps lead from the churning room down into the milk room. The ceiling is plastered, and an attic is left above to keep the rooms cool; a ventilator also opens from the milk room and passes through the roof. Figure 1 shows the general

oscillating rod. Figure 2 shows the interior of the churning room, in which double churns of the ordinary barrel shape are used. This room contains a pump, sink, and wash bench. The butter when churned is worked by a lever worker, the buttermilk being absorbed by a sponge which is kept clean by cold water.

Figure 3 shows the milk room, four feet below the level of the churning room. There are three ranges of shelves around this room, with a table in the center. In the winter this room is kept at a regular temperature of 60° by means of a stove, and in summer is cooled to the same temperature by an inflow of cold air from the ice house which adjoins it. This is admitted through two openings, seen in the wall at the right just above the lower shelf. Figure 4 shows the arrangement of these cold-air pipes in the ice house. A tube passes downwards through the center of the ice, and at the bottom of the ice branches into two arms which are made to turn at right angles, and after passing through the ice appear in the

Bucket for Water Wheels.

Many inquiries reach us as to the best form of bucket for small water-wheels for farm purposes, such as pumping, churning, etc. In reply to such, and more especially to one now before us from a correspondent at Whitley Co., Indiana, which represents many others, we describe a form of bucket which the writer has used with advantage. The main idea in shaping the bucket is to hold the water as long as possible, but at the same time to let it escape at the moment when its power is exhausted in such a manner that it shall not hold the wheel, as it is termed, or that it shall not, by reason of a vacuum being formed in the bucket while it is escaping, be held so that the wheel shall be forced to carry it up some distance before it can be all discharged. This is a point of great difficulty, and can not be secured by any particular form of the bucket, but may be by inserting valves in the lower part of the bucket

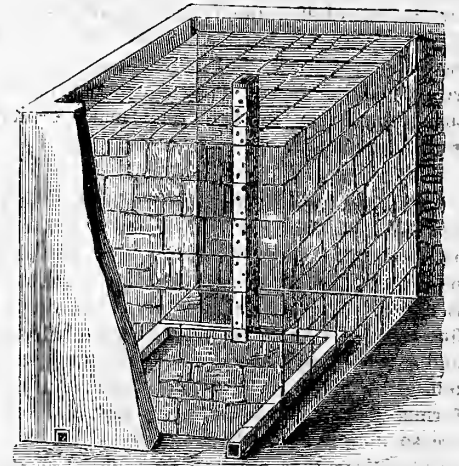

Fig. 4.—ICE HOUSE AND PIPES

by which air may be admitted and any vacuum be rendered impossible. Without entering into

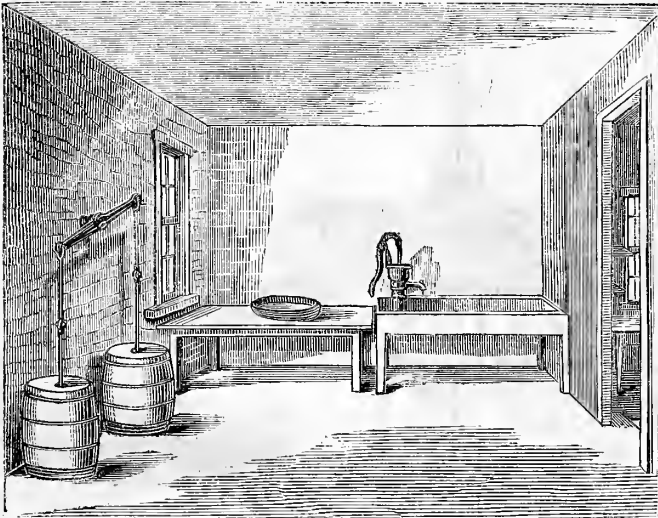

Fig. 2.—INTERIOR OF CHURNING ROOM.

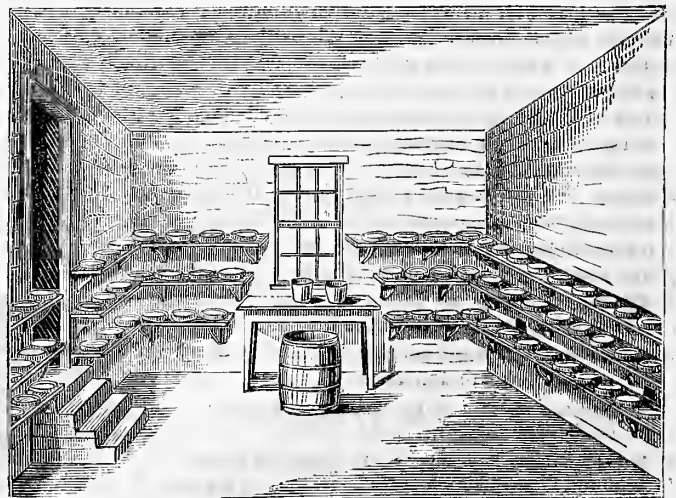

Fig. 3.—INTERIOR OF MILK ROOM.

elevation of the dairy, which is one belonging to a successful dairy farmer in the State of

wall of the milk room. Whenever desirable, a current of cold air, moved by its own gravity,

any of the scientific reasons why the particular form of bucket here described is of advantage,

we simply give the accompanying engraving showing its form, with directions for laying it out upon the sides of the wheel. The engraving represents the circumference of the wheel with the shrouding which forms the sides of the buckets. This shrouding should be divided into three equal parts, which the one included between the inner circle and the dotted line *a, a* will be equal to the length of the starts or soles of the buckets, *b, b*. These should be laid out in the direction of radii from the center or the axis of the wheel, as shown by the dotted lines *c, c*. These lines or radii should be carried out to the outer circumference of the shrouding, as seen in the lines *c, c* in figure 1. The flats of the buckets should then be laid out from the extremity of the starts or soles to the point where the preceding lines touch the circumference, as seen in the dark lines *c, c*. The

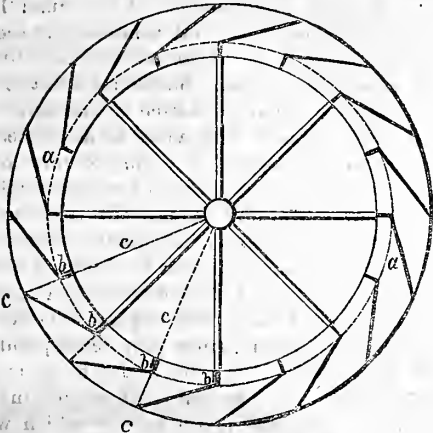

Fig. 1.—LAYING OUT THE WHEEL.

lines should coincide with the number of buckets desired. For these no particular rule can be laid down in these cases, as they will depend upon the length of the buckets and the quantity of water to be used. This form of bucket meets the chief requirements of cases where the

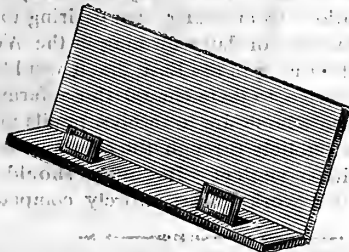

Fig. 2.—VALVES FOR BUCKET.

greatest economy of water is not an object, and will answer every purpose where it is not desirable to employ a skilled millwright. To enable the water to leave the wheel promptly when it runs in tail water a valve or valves of leather weighted with sheet-lead may be affixed to the soles of the buckets, as shown at *b, fig. 1*. As the buckets rise out of the tail water these valves will open and admit air, which will cause the water to escape at once. This simple contrivance has very much increased the power of a wooden wheel to which it has been applied. The way in which the valves are applied to the soles of the buckets is shown in *fig. 2*. They are self-acting, as will be readily understood.

Portable Fence for Poultry Yard.

"E. B.," Ann Arbor, Mich., asks for a portable fence for a poultry yard. Such a fence may be constructed as follows: A post three inches square may be driven or set in the ground and braced, as in the accompanying en-

graving, *fig. 1*. This post is provided with two hooks similar to those upon which gates are hung. Bars of light stuff, which need not be

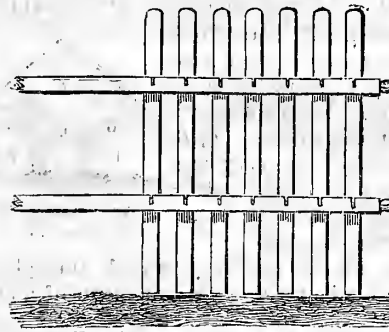

Fig. 1.—PORTABLE FENCE.

heavier than $1\frac{1}{2}$ inch thick by 2 inches wide, are then provided of such a length as the panels may be desired (see *a, fig. 2*). These bars are furnished with eyes at each end, which fit hooks upon the posts. They are also grooved at such distances apart as the pickets are to be placed, or say four inches. The grooves are cut half an inch deep, and large enough to allow a $3\frac{1}{4}$ -inch nail to lie in them and no more. The pickets (*b, fig. 2*) may be made one inch square, and as long as may be desired. If the poultry are heavy-bodied birds, five feet will be enough, as also if the birds are light and have the wings cut. These pickets are bored with holes to receive a $3\frac{1}{4}$ -inch nail, either wrought nails or cut nails which have been annealed. The nails are driven through the pickets in the proper places, and as the pickets are placed in position the nails occupy the grooves in the bars. The points of the nails are then turned down, forming hooks by which the pickets are kept in their places. When the fence is to be moved it may be taken apart and set up in another place with great facility. *Fig. 3* shows a panel of the fence as completed.

BLACK-LEG IN CALVES.—"J. W. R.," Greencastle, Ind. In the spring or the fall, when the feed is changed either from dry to green or from green to dry, it is not uncommon for calves and young cattle to be affected with a very rapidly fatal disease known as black leg. First lameness is noticed in the fore or hind, but generally the hind quarters; the eyes are bloodshot, and the mouth and tongue are hot and blistered. The swellings crackle as the hands are passed over them; and after death, which is generally very rapid, the flesh beneath the swollen parts is black and suffused with

readily be prevented by care at this season. Towards the approach of spring the young animals should be given a pound of linseed-cake meal daily, and the condition of the bowels should be watched. If the dung is hard, and covered with slime or mucus, a few ounces of Epsom salts should be given; when the animals are turned out in the spring to grass it should be for an hour or two only at a time for a few days; and the first appearance of fever should be treated with a brisk purge.

Plan for a Commodious Barn.

W. P., Benton, Grafton Co., N. H., sends us plans and description of a barn built by him upon a farm of 130 acres upon which mixed farming is practiced.

The main building is 108 feet long by 40 feet wide, with 20-foot posts. The wing at the right is 82 feet long by 30 feet wide, with 15-foot posts. The left wing is 40 feet long by 16 feet wide with 12-foot posts. There is a cellar under the main barn 10 feet deep, 80 feet long, and 40 feet wide. As is seen by the engraving, *figure 1*, which shows the elevation, the barn is built upon a hill-side, with three stories. The main floor, of which *figure 2* shows the plan, is reached by a bridge (*B*) which inclines two inches to the foot. *A* is the main floor; *C, C, C* are bays; *D, D* are shoots to the granary; *E, E* are stairs to the floor below; *F, F, F* are hay shoots to the horse stables; *G, G*, store rooms for wool; *H*, chimney, with an 8-inch wall and two flues, one of which is for ventilation.

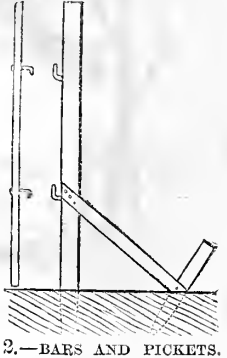

2.—BARS AND PICKETS.

Figure 3 shows the floor containing horse stalls, feed and cook rooms, repair and work rooms, milk room, and shoots for feeding the



Fig. 3.—PANEL OF FENCE.

stock in the stalls and pens beneath, and for passing straw and manure. *A, A* are bays; *B* is the granary; *C, C* are feeding shoots for the cattle below; *D, D*, the passage; *E*, store-room for tools; *F, F*, horse stalls; *G*, manure scuttle; *H*, straw scuttle; *I, I*, stairs; *J, J*, water boxes; *K*, trap for feeding hogs; *L*, wagon

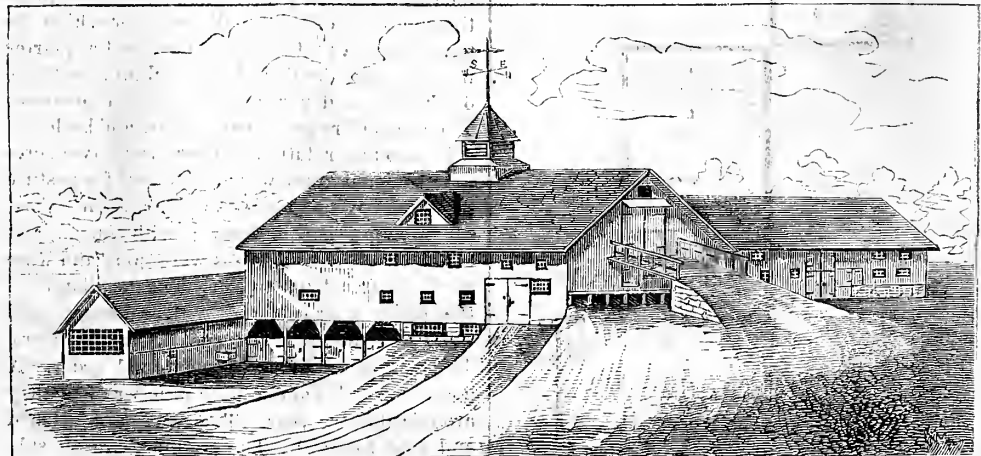

Fig. 1.—ELEVATION OF BARN.

blood. It is almost impossible to cure this disease when arrived at this last stage. It may shed; *M*, steaming or cooking room, which is of brick lined with zinc or sheet-iron, so as to

be fire-proof; N, chimney; O, repair room; P, work room; Q, sink and drain; R, trap for skimmed milk, leading to hog pens; S, milk room with racks.

Figure 4 shows: A, the manure cellar for the

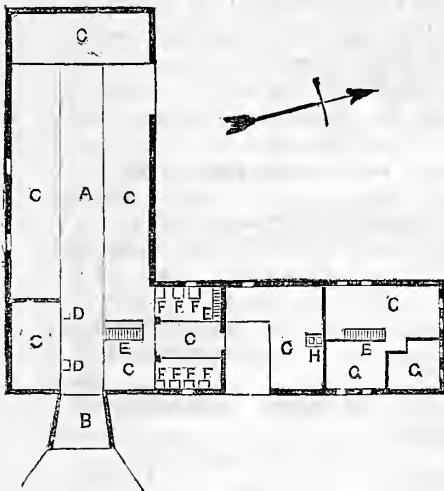

Fig. 2.—PLAN OF MAIN FLOOR.

horse stables, also for store hogs; B, B are pens for fattening swine; with troughs at C, C and doors at D, D. The partitions between the pens are of planks, and may be removed so as to make but one apartment of them if needed for other purposes. E is the stairs; F, water box; G, G, stables for cattle; H, ox stable; I, passage for feeding grain or roots; each stall

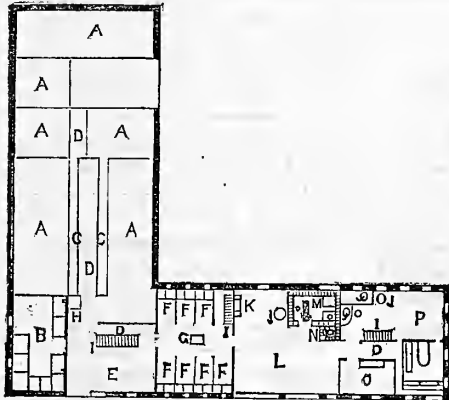

Fig. 3.—HORSE STALL, FEED ROOM, ETC.

being provided with a slide for passing in the feed; S, S are scuttles for manure; T, T, gutters for manure; J, pen for calves, furnished with stanchions and places for milk; K, a loose box

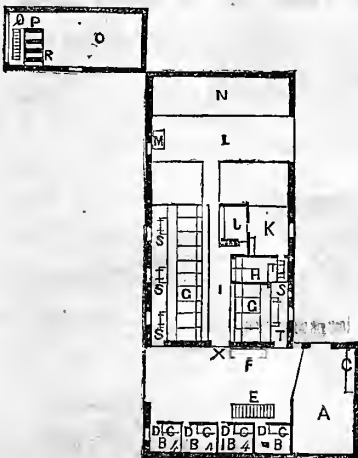

Fig. 4.—PLAN OF CELLAR AND PENS.

or hospital for sick animals or incoming cows; L is the lower floor, 14 feet below main floor; M, hay shoot; N, N, bays; O, loft of shed;

P, hennery with large windows; Q, stairs; R, roosts.

Figure 5 shows the cross section at X, figure 4; A is the main floor, 13 feet wide, 94 feet long; B, B are bays; C, C, loft; D, D, feed passages; E, E, racks; F, F, stables. Figure 6 shows the manure cellar. B, B, place for sheep or young stock; C, C, water boxes; D, D, stairs; E, lower room of hennery.

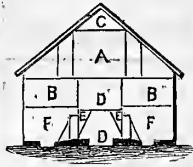

Fig. 5.—CROSS-SECTION.

As will be readily perceived, this plan of barn is adapted to the requirements of a much larger barn, and for a farm upon which the production of manure by high feeding is one of the chief objects aimed at. Its cost is about \$2,800.

VALUE OF ARAB BLOOD.—From the special reports made to the war department of Prussia during the French war as to the efficiency of the cavalry service, we learn that the breed which exhibited the greatest endurance during that war was the East Prussian horse, a race which has a large infusion of Arab blood. They were able to carry a heavier weight than any other race of horses in use in the German cavalry, and far exceeded in endurance even the English troop horses, they also resisted exposure and hardship more successfully, and kept in better condition upon a smaller ration of forage. The captured French horses although much heavier than the Prussian horses, were found to be very inferior. Here is an authentic and strong corroboration of the general opinion as to the value of a thoroughbred cross upon our work horses, or at least upon those in which activity, strength, and endurance are desirable qualities.

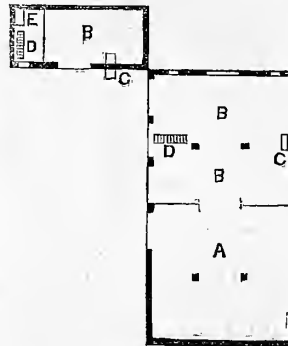

Fig. 6.—MANURE CELLAR.

A LITTLE FARM WELL TILLED.—In the last volume of the Journal of the Royal Agricultural Society of England there is described a farm in Ireland consisting of 13 acres, occupied by a Patrick Clear. The report describing the condition of this small farm, for which the tenant pays a rent of six dollars and a quarter per acre, says the little farm, including cottage, out-houses, and yards, is a model of neatness. The crops were grass, oats, roots, and barley in a four-course rotation. There were two acres in permanent grass, which was kept for pasture for three cows and a horse. The young grass for mowing is top-dressed with guano and compost. The root crops were good and were perfectly free from weeds. The headlands of the fields were planted with cabbages, and there was not a vacant spot upon the farm. The hedges and gates were in good order. A good many pigs and a large number of poultry are raised every year. The calves are fattened and sold for veal. The stubbles are all subsoiled and fall-plowed. This little but excellently managed farm is a good illustration of what may be done upon a very small piece of land by thorough cultivation.

Pupil Farmers.

The old system of apprenticeship had its merits. Although shorn of its ancient usages and bonds it exists to a great and useful extent to-day. That it is gradually coming into use upon the farm is a proof that farming is attaining the rank of an established business in the full significance of the term. Anciently the weaver or "webster," the butcher, the skinner, or "fletcher," the smith, the tailor, or "taylor," and other tradesmen taught their sons their trades as they gave them their names, and the trade became the property of the family as much as the name. No stranger intermeddled with their trades. Such competition was rarely permitted. But society has outgrown this state of things, and the son, not bound by the ancient tyranny of a parental despotism, leaves the farm for other employments. As he quits the farm so other boys leave other homes and seek the farm, or they would do so if opportunities were presented to them. Such opportunities it was hoped would be presented by the agricultural colleges, but that idea has not as yet been realized to any extent. The only resource for such youths or young men is to become pupils of some successful farmer, and learn their business or trade in a thoroughly practical manner, without being hampered with studies for which they have no use. In England and other countries the agricultural journals contain numerous advertisements from farmers who desire pupils, and from young men who desire to become pupils, and the same system is already originating here. Not long ago a case in which we were the means of bringing master and pupil together, has resulted so satisfactorily to both parties that we recommend its repetition in other instances. Doubtless there are many successful farmers who would receive pupils, and hundreds of young men who would gladly seize upon an opportunity of becoming pupils to such farmers. We so very frequently receive applications from young men desiring to learn stock farming or dairy farming in the West, or general farming in the East, that it would be of great service to them should those farmers or dairymen who desire to receive pupils make it known publicly through the columns devoted to business matters. But none should enter upon this work unless entirely competent.

A Safe Cattle Tie.

We recently met with a case in which a careful farmer, making the usual rounds of his stables the last thing before retiring at night, discovered a valuable cow fast with its foot over the halter, the halter being fastened to a strap around the animal's neck and to a hole in the feed trough. It was extremely probable that the cow would have been strangled before morning had she not been relieved. There are two things to be learned from this accident. The one is that no farmer should neglect the practice of seeing that all is right with his stock the last thing at night. The other is that such a fastening as above described is very unsafe for either cattle or horses. A tie that is as safe as probably any tie can be made is here shown. It is one that we have used for cattle, both oxen and cows, for several years without any accident or mishap whatever. A ring or eye-bolt is securely fastened in the side of the stall above the level of the feed trough. Through this ring the rope tie is passed. One

end of the rope is passed through a block of wood and knotted so that it can not be drawn out. This end hangs down below the ring. The other end is also knotted in such a way that the knot can not slip. This end of the rope is passed around the horns of the cattle so as not to be too tight, and the knot at this end is put through a loop made in the rope at

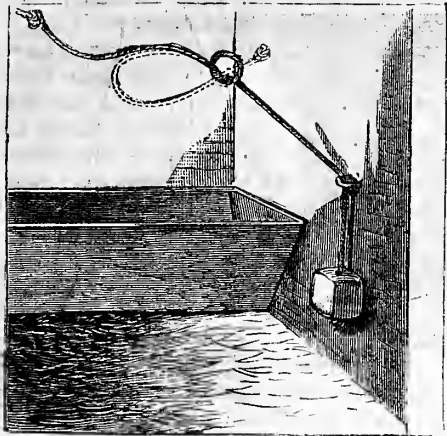

A SAFE CATTLE TIE.

such a distance from the end as to leave sufficient length to go around the horns. When the cattle are up the slack of the tie is drawn down by the weight of the wooden block, making it impossible for the animal to get its foot over it. When they are lying down the block is drawn upwards, but still keeps the rope safely out of the way. We have found this tie equally useful for horses.

Three-Horse Whipple-Trees.

A set of three-horse whipple-trees is shown in the engraving here given. They are arranged upon a compensating plan, by which the middle horse has twice as great a length of the whipple-trees as each outside horse, thus

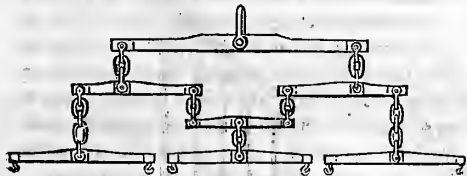

THREE-HORSE WHIPPLE-TREE.

equalizing the amount of draft. The engraving shows this so clearly that it is only necessary to follow the plan exactly in making the whipple-trees. They are connected together by ordinary clevises and bolts.

MIXED GRASS.—At the annual meeting of the Mass. Agricultural Ass., a paper was read upon growing grass. In the discussion which followed it was remarked that farmers should be careful to sow together only those grasses which ripen at the same time. This is a mistaken idea. The chief reason why a variety of grasses should be sown is that there may be a constant succession of growth. The weakest point of our meadows is that the grass ripens, fades, and suspends growth for the season, leaving a brown, withered, or bare surface. If there were a succession of consecutively ripening grasses there would be a continued greenness and verdure, and if the pastures were only not overstocked this would be as great an approach as we can make with our peculiar climate towards a permanently green meadow or pasture. But if all the grasses ripen at once

we may as well continue to grow one single good grass as several good and bad ones.

Butter and Cheese Dairying.

We have watched with great interest the progress of the "dairymen's conventions" which were held during the month of January. Feeling the importance of these institutions to the interests represented by them we devoted some time to attend them. We may say that we were particularly interested and gratified with the energy, enterprise, and intelligence exhibited by the Associated Dairymen. The papers read at these meetings were of great merit and usefulness, and the speeches and discussions which followed the remarks of the orators were marked by great practical experience and intelligence. This fact promises well for the continued success of the dairy interest, which now represents an annual value of nearly 500 millions of dollars. The cheese manufacture of the country is expanding with great rapidity, and its expansion is but the natural consequence of a vast improvement in quality. The renowned Cheshire and Cheddar cheese of England is to some extent met and vanquished upon its own ground by American cheese. Many brands of American make are sought for with avidity by English dealers. Twenty years ago American cheese was a drug in the English market. But the factory system has not only changed all that, but it has from its inherent value and excellence forced its recognition and adoption by English cheese-makers. And this is but the beginning of the existence of the cheese industry of this country, for the home consumption has hardly as yet been created. To stimulate this growth and encourage an extensive home market the attention of dairymen needs now to be turned, and the tastes and demands of consumers must be learned and met. As regards butter, dairymen have much to learn, especially those of the West. The quality of the butter that comes to market is in large part wretchedly bad. This is the consequence of faulty feeding, of careless churning, but in far greater part of improper packing. The produce dealers are also to blame to some extent for this. It is true that low-priced butter is needed for a portion of the consumers who are poor and can only afford to buy a cheap article; but it costs no more money to make a fair tub of butter than a poor one, while its value is about double that of the poor one. The secret is almost entirely in cleanliness—clean feeding, clean milking, clean keeping and churning, and last, but really the most important of all, clean packing. We are glad to believe that the meetings of the dairymen will gradually lead to improvements in these respects, and we propose to work for that end along with them.

PERMANENT GRASS.—Water meadows are amongst the most productive of permanent grass lands. But the management of water meadows is very frequently injudicious. No cattle should be allowed upon an irrigated meadow, nor should the water be permitted to run continually over one spot. A meadow thus treated very soon becomes a morass, and is then spoiled. A dressing of bone-dust is remarkably beneficial to water meadows, greatly thickening the grass and improving the quality of the hay. An application of plaster the next year still further improves the meadow. As soon as the hay becomes inferior in quality and decreases in quantity it is restored by a repeti-

tion of this treatment. The opportunities for making water meadows are frequent, and as their value becomes appreciated they will become much more common than they now are.

THE VALUE OF SKILL.—In the report of the Ayrshire Agricultural Association recently held in Scotland, we read of an Ayrshire dairyman who had been in the habit of making Dunlop cheese, the common cheese of the country, but on changing his make to that of Cheddar cheese realized an additional profit of \$5,000 in five years. The Cheddar is classed amongst the fancy cheeses and brings a high price; but as there is nothing needed in its manufacture but an extra amount of care and skill, we see how the exercise of these qualities pays in comparison with simple labor. Amongst ourselves there is a great opening for the profitable exercise of skillful dairying in the making of cheese, to meet a large demand for something of extra quality and attractive and convenient form.

IN AND IN BREEDING.—In building up a breed or race of cattle some of the most noted and scientific breeders have resorted to very close breeding. They have not scrupled to use bulls upon their own dams or heifers when by doing so some desired point was to be secured. But it by no means follows that this practice is to be adopted as a rule. A scientific and successful stock breeder is one of a thousand, and while he may be successful in some of his ventures—and, as it must be remembered, we do not hear of his failures, the evidence of which he instantly destroys to save his reputation—others may find that his methods may be to them merely playing ignorantly with edge-tools.

SALT FOR HOGS.—The unrestrained appetite of swine will often lead them to consume things that are highly injurious to them. Cases of poisoning by partaking of excessive quantities of salt often occur amongst hogs at this season when beef and pork barrels are emptied of the old brine and refuse salt. A case in which several hogs were thus lost in England, was recently noted. Hogs require a certain amount of salt as do other animals, but it should be given to them with caution, and either evenly mixed in their feed or scattered very thinly about their troughs, so that one more greedy than another can not take more than its proper share.

A Punch for a Bull's Nose.

The uncertainty of a bull's temper renders it necessary that he be held in safe control. He is only safe when held by a strong ring in his nose. We have before described one method of ringing a bull (*American Agriculturist*, June, 1872). We now figure a punch for piercing the hole in the cartilage between the nostrils by which the

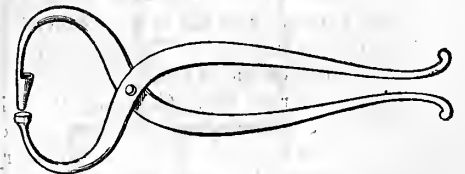

PUNCH FOR A BULL'S NOSE.

operation is rendered easier and safer. It is made of similar shape to a pair of common pincers of large size. One of the jaws is provided with a hollow punch of conical form which takes out a round piece of the cartilage. The bull should be tied by the horns and seized

in the proper place by the punch, when the perforation of the cartilage is the work of an instant. During the operation the animal is powerless, for the handles of the punch being curved and made with knobs at the ends furnish a very secure means of holding him while

the separator, the cleaned grain runs through spouts into hoppers or bins, in which it is stored, or from whence it is passed through the pipes seen in fig. 2 to the stones. Here it is ground, and the meal, considerably heated by the friction of the stones during the process of grind-

passes, upon which tin cups are fastened. The strap passes over a pulley at the top and another at the bottom of the elevator, and as the cups pass up they scoop up the flour as it pours into the box at the bottom and carry it upwards, throwing it out as they pass over the

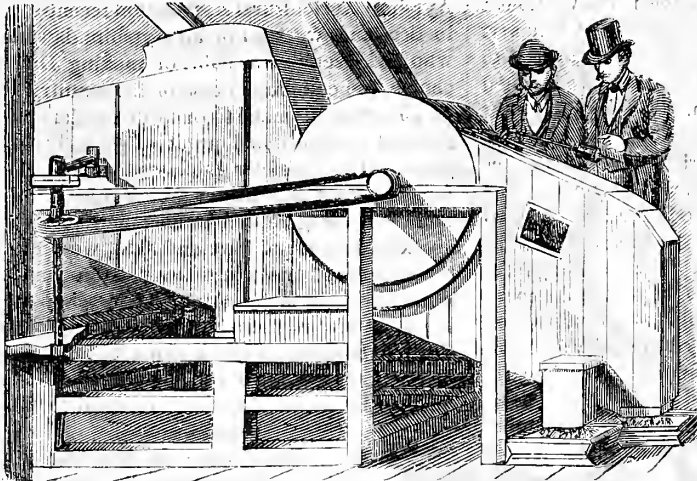

Fig. 1.—SEPARATOR.

the ring is being made ready. The hole being perfectly round too, heals again very quickly, and can not tear open as a three-cornered hole might do. The operation of ringing should be performed before a bull becomes a year old. Then he is always in a state of subjection, and not knowing what it is to successfully resist his keeper is not so apt to try to do it as when older.

The Flouring-Mill.

Much of the grain which arrives at the Eastern ports is ground into flour for consumption or for export to foreign countries. Some of the flouring mills engaged in this business are

ing, is cooled by being carried up through an elevator two or three stories above to the bolts, fig. 3. The bolts consist of long reels covered with very fine and costly silk cloth. This bolting cloth is made only in Holland, and is of various degrees of fineness. Each long reel is covered with cloth of three qualities in such a way that the bolt is divided into three partitions as it were. Through the first of these the finest flour is sifted; the second separates the second quality or coarse flour; and the third the shorts, middlings, or fine "mill stuff," which is either taken by a spout or conveyed into the stones and ground over, or it is kept apart to be sold for feed. In the largest mills there are three separate bolts or reels, as seen

upper pulley into other spouts. The conveyers are horizontal pipes or spouts, in which rods furnished with screws similar to the propellers of steamboats push the flour along. The packers are large conical receivers into which the finished flour is gathered. The barrels are placed beneath them, and as the flour pours into the barrels a revolving screw presses the flour down closely into them until they are filled. They are then weighed, 196 pounds of flour being put into each one, and are headed up. The last operation the flour undergoes is inspection. The inspector bores a hole through the head of the barrel, inspects the quality of the contents, and marks the appropriate brand upon the head. It is not necessary, however,

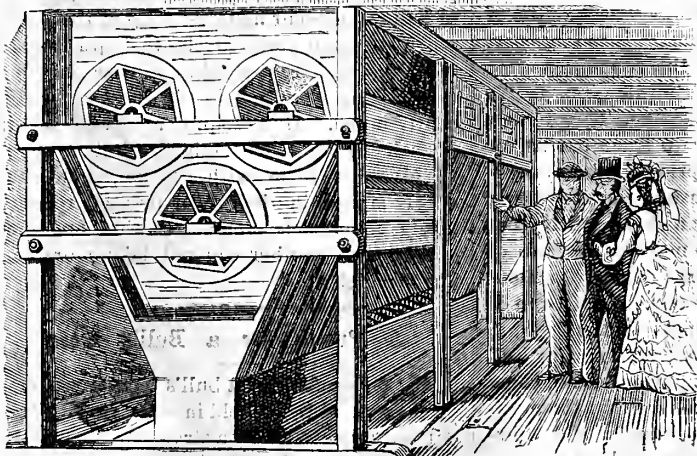

Fig. 3.—BOLTING MACHINE.

very large, and turn out several hundreds of barrels of flour daily, a few even grinding a thousand barrels or more every twenty-four hours. The accompanying illustrations represent the interior of one of these mills of a comparatively moderate size. Generally the mill is a solid brick or stone structure of six or seven stories. The grain is elevated to the top story, where it is passed into the smut machine, in which it is separated from the dust and fine dirt. From thence it passes through a spout into the separator or screen, in which it is freed from all shrunken grain and all the large foreign matter. Generally these two operations are performed by a combined machine as shown in fig. 1. After having passed through

in fig. 3, and the meal passes from one to another, being separated in its passage into the various qualities described. Very frequently the bran is ground over again, so that every particle of the flour of the grain is separated from the husk. Although the flour thus made is neither the whitest nor the finest it is nevertheless the most healthful, because it contains a larger portion of the phosphates of the grain, or that part of it which goes to make up the material for supplying the growth or the waste of the brain and the bone. An intricate arrangement of elevators and conveyers takes the various grades of flour separately into the packers seen in fig. 4. The elevators are square wooden pipes, through which a leather strap

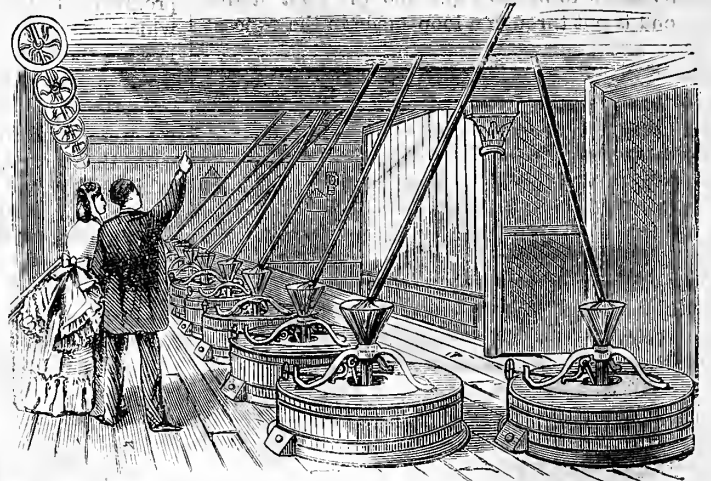

Fig. 2.—STONE ROOM.



Fig. 4.—PACKING ROOM.

that this should be done within the mill. A large quantity of flour is inspected upon the wharves or in the warehouses. But the inspection brand is a satisfactory certificate as to quality, and purchasers may safely depend upon it as a guarantee. A large portion of flour enters into use in the arts or manufactures. Sour or unmerchantable flour is largely used as size or dressings for cotton warps or for bleached muslins. In the first case it is used to stiffen the threads to facilitate the process of weaving, and in the second case to fill up the interstices between the threads and to give it a body, so as to make thin, light goods, more attractive to purchasers. Bran is also used largely in the processes of dyeing and calico printing.

Butterfly-Weed—Pleurisy-Root.

There are few of our native plants more brilliant in flower than the *Asclepias tuberosa*, which is showy enough to have two common names, Butterfly-weed and Pleurisy-root. We do not know whether it received the first-mentioned name because it is "as beautiful as a butterfly" or for the reason that it is attractive to those insects; it was called Pleurisy-root from the fact that it has long been used in domestic medicine, and it has received some attention from physicians. It belongs to the genus *Asclepias*, or Milk-weeds, but, unlike the rest of them, it has no milky juice. The large, fleshy, and branching root throws up several stems one to two feet high, which, as well as the scattered or opposite leaves, are hairy. The stem usually branches above, each division bearing an umbel of brilliant orange flowers. The flowers of this genus of plants are difficult to describe in a popular manner; indeed, their structure is so intricate as only to be understood by those who are well versed in botany. Our object is, however, to call attention to the plant as an ornamental one. Here is a plant that is not rare "from Maine to Georgia" and further south, that is highly prized in Europe, and offered at a good price by the European florists, that is very rarely seen in cultivation. Its native localities are dry fields, and we have



BUTTERFLY-WEED—PLEURISY-ROOT.—(*Asclepias tuberosa*.)

and though not so brilliant as this one, are interesting plants and worthy of cultivation.

A Double Carolina Jessamine.

In April of last year we described and figured *Gelsemium sempervirens*, the Carolina or Yellow Jessamine, that is so conspicuous during the spring months all through the Southern States. This winter we have flowered in the greenhouse a double variety of this charming plant. We give an engraving which shows that it is quite like the other, only double. As the history of this plant is interesting, as showing how near a variety may come to being lost, we give it. Last spring, our friend P. J. Berckmans, of Fruitland Nurseries, Augusta, Ga., sent us a specimen, one of several that he had received from a lady in Louisiana, which was planted out in a bed with several other southern plants. When Mr. Berckmans was at our place last fall he asked about the Double Jessamine, and as it could not be found we supposed that, like many other things in the bed, it had been killed by the early drouth. Upon taking up our plants for the winter we found that it had been hidden by some quick-growing thing, but was in good condition. We wrote Mr. B. that the missing plant had been found, and he at once replied that he was rejoiced to hear it, as his plants had failed, and that the lady who sent it had died, so that he could get no more from the original source, and that we had, so far as known, the only plant in cultivation. The moral of this bit of experience is that those who have rare plants of any kind can best save them by sending a specimen to us.

The Fragrant Olive.

There are persons who expect to find every admirable quality in one plant. Such are not satisfied with the Camellia because it is not fragrant, and they would not be pleased with the Fragrant Olive, which, though fragrant enough, is not showy. But to those who are content with a plant as nature made it we can commend the Fragrant Olive. It is a native of China and Japan, where it forms a large shrub or small tree; it is an evergreen, with thick, ovate, pointed leaves, which are irregularly serrate on the margin; it bears clusters of very small yellowish white flowers, as shown in the engraving. The fragrance of the flowers is something remarkable; it is pervading without being powerful, and is not oppressive like some odors. We know of no other odor with which it fairly can be compared, as it stands alone in its refined excellence. The Chinese are said to mix the flowers with the choicer kinds of tea for the purpose of flavoring them. The plant succeeds well in the Southern States. Mr. P. J. Berckmans, at Augusta, Ga., has a particularly fine specimen growing near his house, which is eight feet or more high. We have a couple of small plants in the greenhouse, neither of which is over a foot high, which have been covered with flowers for weeks. We have not tried, it as a window plant, but from its behavior else-



FRAGRANT OLIVE.

where do not doubt it would answer admirably. We call the plant Fragrant Olive, as that is the translation of one of its botanical names, *Olea fragrans*. Some botanists put it in another

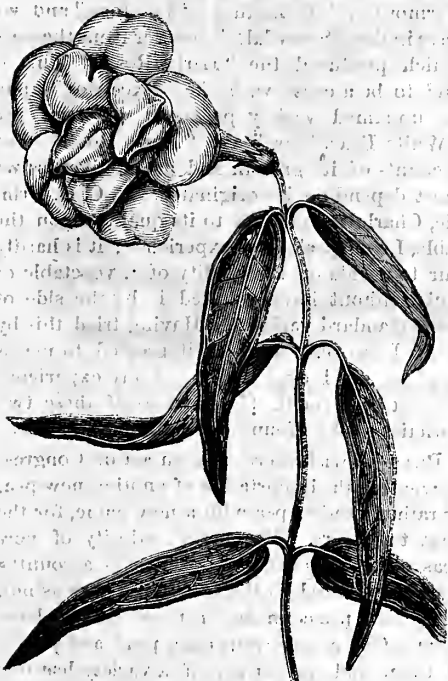

DOUBLE CAROLINA JESSAMINE.

seen it at the South remaining as a weed in cultivated grounds. It does well in ordinary garden soil. We have a clump which throws up an annually increasing number of flowering

genus, *Osmanthus*, which means odorous flower, but as the fruit is not known either in cultivation or in its native countries, its botanical position can not be fixed with certainty. Those who object to botanical names may take it under the Chinese, *Hoa-monc-tay*.

Packing Living Plants.

We often receive letters asking for directions about packing living plants to send by mail or express. These letters of course come from persons who are not florists or nurserymen, but we have received plants packed so poorly, from those who ought to know better, that we will give a few directions, which may be useful to both the professional and amateur florist. The best material to use in packing is what is known as "Sphagnum," a kind of moss common in bogs and wet places; other kinds of moss will answer, but as they do not absorb and retain moisture so readily are not so good. The amount of moisture necessary to preserve plants during their transit will vary with the season, and also the length of time it will take for the package to reach its destination. For plants which will be on the road from ten days to two weeks during the summer months, the moss should be only very slightly dampened; press the moss firmly in the hands before using, this will remove the excess of moisture, and still leave it damp enough. When plants are sent by express, procure a box of a size sufficient to contain them, and have it properly nailed so that it will not be broken during the journey. Then remove a portion of the soil from the roots, wrap the moss around them to a thickness of half an inch, and tie it firmly on with twine. After all the plants have been thus prepared, place a layer of dry moss or straw on the bottom of the box two inches thick; then place the larger plants, such as shrubs and trees, on this moss, crowding them firmly down, so that there will be no danger of shaking out of place; to prevent any movement braces are often placed across the inside and fastened with nails driven through the side of the box; this last plan is mostly used when plants are sent in pots. Finish off the top of the box with the smaller plants, and cover the whole with a layer of dry moss, which will press so firmly upon the plants, when the cover is fastened, as to prevent any shaking. If the box is deep there should be one or more layers of moss or straw used, as there is danger of heating when too many are packed together. Cactuses and most succulent or thick-leaved plants require packing in dry moss, for otherwise they rot. Water plants, such as the various pond lilies and pitcher-plants, need a greater amount of moisture than ordinary shrubby and herbaceous plants.

SENDING PLANTS BY MAIL.—The law passed some years since by Congress, allowing packages of plants to be sent by mail, if not over four pounds in weight, was a capital arrangement for those who lived at a distance from railroad and express offices, but it is so hampered with the various constructions given by the P. O. Department, that it is difficult to know what is required by the officials. The law now is, we believe, as follows: A package weighing four pounds or less, can be sent at the rate of two cents per four ounces, but the writing of the words "roots" or "plants" makes a letter of it, and is charged letter postage. Nothing should be written except the address, and the

package must not be sealed, or contain any writing, and it must be so fastened that the postmaster can examine the contents if he wishes. The plants may, however, be numbered, and their names sent by letter.

Many contrivances have been made for packing, but none are better than sphagnum and oiled paper when they can be had. Lay down a piece of oiled paper of the proper size, spread a thin layer of dry moss upon this; remove all the earth from the roots of the plants by washing, lay them upon the moss, and roll the whole tightly; then inclose in a strong wrapping paper without sealing. Plants sent in this way will remain in good condition for two weeks at least. Where oiled paper can not be had, the next best thing is a cigar-box, as it is light, and may be had almost anywhere. The moss must be dampened as for sending by express, as evaporation will be more rapid than in oiled paper. When plants are sent either by mail or express, a portion of the leaves should be cut off, and they arrive in better condition when a large part of the top is removed in the case of all trees and shrubs, with the exception of evergreens. Herbaceous plants, or those the leaves and stems of which die down every fall, should be cut back to within two inches of the roots. Use strong twine in tying the boxes, and do not wrap in paper. Bulbs not in a growing state must be packed in quite dry moss or chaff of any sort. When plants are sent out during cold weather or in the fall or early spring, the moss ought to be drier than that used during the summer. Those sent to us from California and the far West need rather more moisture, as they are on the road so long. It should be borne in mind that more plants are ruined by being packed too wet than too dry.

Notes from the Pines.

NOVELTIES IN VEGETABLES.

[We have usually this month given a list of the well-established and new vegetables as a guide to the inexperienced in gardening. Now the varieties that we consider the best of each kind will be enumerated under "Kitchen Garden" on page 83; and we will allow our correspondent from "The Pines" to have his say about the novelties offered this spring.—Ed.]

THE CATALOGUES HAVE COME!—At least most of them have, and I have had a grand time over them. If there is one thing I do thoroughly enjoy more than another it is a seedsman's catalogue, except it be a florist's or nurseryman's. A fairy story book is no more a delight to a boy than a catalogue to a true lover of plants. I have a friend who is so fascinated with a new catalogue that he will read it in bed, much to the annoyance of his wife, who, as every right-minded person will admit, has abundant grounds for a divorce. I pity the seedsman. If they do not have on hand every novelty offered in Europe, they lack enterprise, and if they have all these novelties and they, as nine-tenths more or less of them are sure to do, fail, the seedsman has all the blame. Every one is not expected to try every new thing—much less depend upon untried kinds for his main crop. If you were to offer to our shrewd Jersey market gardeners new seeds free of cost, they would not give up their particular pea and cabbage which they can count on almost to a day, and their celery which never failed to bring them handsome

returns. But I tell you what they would do: they would "take a few to try," and that is the whole story. Stick by well-proved sorts and test the new things as they come out. Fearing Burr, than whom there is no better authority on vegetables, once said to me, "If we add but one new variety of value to our list each year, we are making great progress." Unless a new variety is in some particular better than the best we now have, it will not have much chance of being permanently adopted. Next to supplying an abundance of fresh vegetables of the best kinds, my garden is valuable as a place to test novelties. Nothing in gardening gives greater pleasure than watching the growth and development of a new thing grown for the first time. I do not advise people not to purchase novelties, but to regard them as things on trial. Put in the regular crop of the standard sorts, and as many novelties as can be properly cared for or the purse can afford. Be prepared for disappointments; do not expect that a variety will grow the same in our hot summers as it does in England, or that a variety that originated in New Jersey will be adapted to Canada.

POTATOES stand on the border line between the field and garden. Early potatoes are properly considered as belonging to the list of garden varieties, and trial specimens of late kinds will usually find a place in the garden. Some of the English horticultural journals had so persistently written down our potatoes as a class, I had supposed that our varieties were as little adapted to English soil and climate as are their varieties to ours. Since several of our kinds that were in a trial of over 300 at the Horticultural Society's Gardens at Chiswick [see Jan. last, p. 19] received a first-class certificate upon their merits only, they having been grown under numbers, we are forced to believe that much of the former depreciation of our potatoes was due to prejudice. Among these varieties was one that had not been offered in this country, "Brownell's Beauty." The "Snowflake" is another new variety sent out by Messrs. Bliss. Virginia's reputation as "the mother of presidents" bids fair to be eclipsed by that of Vermont as "the mother of potatoes," and we have in the "Snowflake" another from the state which produced the "Early Rose." This is said to be a cross with the "Excelsior" upon an unnamed variety produced between the "White Peachblow" and "Early Rose." For accounts of its growth and productiveness we must depend on its originator, Mr. C. G. Pringle, Charlotte, Vt. As to its quality upon the table, I can speak from experience; it is hardly fair to decide on the quality of a vegetable or fruit without having tested it by the side of some standard varieties. Having tried this by itself I can only say that it seemed to me as good as any I ever tried—and my experience has not been small. [Engravings of these two varieties will be found on another page.—Ed.]

PEAS.—I wish there was an act of Congress preventing the importation of another new pea, or rather another pea with a new name, for the next ten years. The great majority of new peas come from England, which is a country eminently suited to the pea, while ours is not. They have pea connoisseurs there, and we have none. Our people want good peas, and plenty of them, and do not care if a variety has one more pea in a pod than another, or six more pods to the haulm, or is fifteen or twenty minutes earlier. It is very probable that so far as our climate is concerned we have reached as near perfection as possible with the pea, until

our own growers give us a variety which will give us a dozen pickings instead of two, and will not go in a fit of mildew with the first hot days. The catalogue descriptions must be a great puzzle to the novice; we read in one of "McLean's Little Gem," emphasized by italics, that it is "*The very best early dwarf wrinkled pea grown.*" And directly below is "McLean's Blue Peter," of which we read: "A decided improvement upon 'Little Gem,' and that is saying a great deal." Better than the best should be good enough for any one. I have not a word to say against "Blue Peter," for I have found it a tip-top variety, but wish only to show the perplexities that beset the novice. Fortunately there are but few new ones this year, among which are: "McLean's Best of All" (until he gets one better), "Nelson's Vanguard" and "Suttou's Jersey Hero," each of which, as a matter of course, embodies all the good qualities belonging to any pea; at least so say the English descriptions. In the way of

TOMATOES I have seen but few new ones in the catalogues. "Belle de Denville," from France, and "Extra Dwarf Red," both by Briggs Bro., and "Alliance" by Vick, are all that I have thus far come across. As a matter of duty I shall have to try these, though I place but little reliance upon one person's experience in one year. From my last year's trial only I should be warranted in writing down "Canada Victor," "Hathaway's Excelsior," and others as failures, but I know that they are not, for the "Excelsior" has given satisfaction both at home and abroad, and a grower who lives about three miles in a straight line from me, thinks that the "Canada Victor" is the finest tomato grown. He sold a number of single specimens for seed at a dollar each—while I would not have given that sum for my whole crop of a dozen plants. Why the difference? He has a stiff rocky soil, on a high hill, while I live in a valley, on a light soil, without a stone handy to throw at a strange cat. Then again my friend has no end of glass, while I being cramped for sash room, did not get my plants forward early, and when I did set them out, it was on the edge of a dry spell which continued so long as to make them forget all about growing. The "Trophy," which I have grown since it first came out, has each year been perfect, while the neighbor referred to says he can not thoroughly ripen it. Our standard varieties are so good that it will be difficult for any new comers to excel them: the same may be said of

LETTUCE, to which our climate is not very favorable. I stick up my stake at the Hanson, introduced a year or two ago by our lamented Dreer. Unless a new variety can surpass that, it is of no use. "Satisfaction" (Vick), "Green, Fat Cabbage" (Bliss), and "Kingsholm Cots" (Dreer) are the principal new sorts. Get the seed in the hot-bed early this month, and put out the plants, first properly hardened, as soon as the soil can be worked.

LEEK.—There may be a difference in leeks, but so far as I have seen it is mostly in the labels on the seed bag. A new one called "Extra Large Carentan" claims to be bigger, better, and all that, than any other.

SQUASH.—It seems a great piece of presumption for a new squash to come from anywhere except Marblehead. This time it is French, and called "Round-warted Marrow," described as of medium size, fine quality, a good keeper, and more than all, it is "warted all over."

CUCUMBERS.—We have the Russian Netted

and Swan Neck from Briggs Bro. and Henderson & Co. Several new frame sorts are offered.

MELONS.—The only new ones I have noticed are Prescott (Dreer) and Green Climbing (Briggs Bro), which last is said to be cultivated on trellises and poles, and a "most excellent novelty."

BEANS.—Gregory offers the "Marblehead Champion," which is a pole bean and of remarkable earliness. He says "as early or earlier than the earliest bush varieties." Gregory "knows beans." Crosman Bros., Rochester, have the "White Advancer," for which earliness and great productiveness are claimed.

These are about all the important novelties, and it is to be distinctly understood that whatever is said of them is on the authority of the catalogues. Later, I hope to speak from personal knowledge.

A New Trick of the Robin.

It is well known that most wild creatures have a strong preference for particular kinds of food, and will seldom try experiments with new sorts so long as they can find the food they are accustomed to. Trout which feed upon flies will hardly look at anything else while the season lasts. Rabbits that have been accustomed to sweet apples around their favorite haunts will follow that bait into almost any trap laid for them. Robins while rearing their young in the nests live almost exclusively upon grubs and worms, the old birds devouring with disgusting greediness what the nestlings imperfectly digest. While the cherries last, their favorite haunt is the cherry-tree, and nothing but shot can dislodge them. When the currants begin to redden they perch upon the neighboring fence, and little else than currants can be found in their crops. In some places they are accused of eating peas in the pod, and by the sea-shore discarded fish-nets are thrown over the pea-brush to keep off the intruders. All kinds of small fruit suffer in their turn, and if left to follow their own instincts, the fruits in small gardens will generally be cleaned out by the robins. For the first time the past season we noticed the robins pecking away at the Flemish Beauty pears. This was the only kind assailed in a fruit yard of a dozen or more varieties. They usually commenced operations upon the blushing cheek, just as it began to ripen. Have these birds an esthetic nature, and do they admire beauty of color? They followed the pears as they dropped upon the ground, and rivaled the chickens in scooping out the luscious pulp with their beaks. Did they learn this trick of the chickens, and are they susceptible of education? Have they a nicer taste than the chickens to discern the better flavor of the Flemish Beauty and to leave Buffums and Bartletts untouched?

Raising Tomato Plants.

BY J. B. ROOT, ROCKFORD, ILL.]

There are few crops in which the gardener so much desires to secure earliness as the tomato. But poor success does he have with the sickly, slender plants so generally offered for sale, which recover so slowly from transplanting as to fruit but little earlier than plants raised in the open ground. Consequently they meet with little demand. But offer on the same stands stocky, tree-like plants, well hardened and already in bud, which can beset in the garden without a day's hinderance of growth, and nearly every owner of a garden who sees

buys of them, though the price be ten times that of the frailer sort. Such plants are best secured by the following treatment:

Late in February we make our first sowing, and repeat it every week or ten days to keep up a succession and to provide against accidents. For this purpose use light boxes filled nearly full of compost which can be easily lifted in and out. The cheapest are second-hand boxes from grocery stores, which can be split after the cover is nailed on and made into two. At this season of the year the bed must be a deep one, with abundance of heat, and the plants will then put in an early appearance, and should remain in the same boxes until they touch each other between the rows if the rows are an inch apart. They are then transplanted into other boxes an inch apart each way. Cases in which oysters in the can have been shipped, split into two, are cheap and very convenient, and thirteen usually fit neatly into a frame 12 x 5½. Here they are allowed to remain until they again touch and crowd.

For their next receptacle we provide quart oyster cans cut into two. This makes of each can two neat, stout tin boxes three inches deep, two wide, and three long, and these are convenient for so many uses in plant growing that it may be worth while to describe how they are easiest cut and fitted for use. To hold them while being cut, make and screw to the work-bench a stout frame or box just large enough to hold a can on its broadside, together with a wedge to tighten it. Saw-cuts directly opposite each other should be made in the box. Placing a short stiff-backed saw in these cuts, a few quick strokes answer to cut the can in two. Of course, the saw dulls quickly, but cuts well even if dull, and can be quickly touched up with a file and kept sharp enough. Fitting each half-can over a piece of hard wood of the right size, two or three quick strokes serve to make holes an inch square in the bottoms if they have not already been made. The jagged edges are then hammered smooth, and a pine chip covering the entire bottom, and yet not fitting tightly, is put in. This serves a double purpose: it secures drainage, without which a plant will not flourish, and also serves as a means to remove the plant undisturbed from the can when wanted.

Into these half cans filled with rich compost the plants are then removed with as much dirt as can be easily lifted with them. If the cans are then allowed to stand a few minutes in an inch of water, and the bed for a day or two is protected with lath screens, the plant scarcely stops growth, and soon fills the can with a perfect mass of roots.

When ready for sale they are placed for a couple of days several inches apart on boards in some place where the air circulates freely, and are thus hardened.

In these cans, if occasionally watered, they receive no injury if exposed for sale on the stands for days together. Carried into the garden they can be set out undisturbed, and without injury to the can, by giving a steady pressure against the chip from below, by which the plant, roots, and soil altogether are taken out undisturbed. One hardly realizes how nicely this is done until he has tried it.

To accommodate parties buying largely, and wishing to get them cheaper, and also for use in my own market garden, they are transplanted into boxes holding from one to six dozen each when given the same space as in cans. To secure extra fine plants for early market purposes the plants are given another transplanting

into boxes two inches apart before putting into cans; and a couple of days before each transplanting a knife is drawn between the rows of plants each way in the boxes, which serves as root pruning and induces a new growth of a mass of roots, and also induces early fruiting. It also gives the plants a wonderful start, if after setting out in the garden the soil about the plant is thoroughly drenched with manure

A Climbing Fern.

Among the ferns there are a few with twining stems. We have one, a native of this country, which though not very common is pretty widely distributed, it growing from New England to Kentucky and Tennessee. This—the *Lygodium palmatum*—is much sought after for drying for ornamental purposes, and is inter-

months as a parlor plant, and it has thus far grown finely. Should it prove able to withstand the dry heat of our dwellings it will become a most popular window plant.

The Canada Burnet.

One of the noticeable plants of our Northern swamps and wet meadows is the Canada Bur-



CLIMBING FERN.—(*Lygodium volubile*.)



CANADA BURNET.—(*Poterium Canadense*.)

leachings so diluted as not to endanger the life of the plant.

I am confident that the use of these half cans for almost any purpose in place of pots will be found satisfactory. They do not break in handling, they waste no space in the bed, pack solidly in the oyster cases so as to ship any distance, and are good for years. Restaurants and hotels are usually glad enough to get rid of the cans, and two boys 15 years of age will fit for use 300 to 400 in a day. I have been offering for five years plants grown in this way, and the demand has grown so that they have almost entirely supplanted all others, and I commend them to my fellow gardeners with great confidence that they will please.

[It may be well to add, for the benefit of those who live where they can procure oysters directly from the shell, that the West is supplied with oysters put up in Maryland and Virginia in tin cans of various sizes. These cans are not round, like those for fruit and tomatoes, but have flat sides, being of the shape and not far from the size of a brick. Immense quantities of oysters thus packed are sold every winter in the Western towns and cities, and they usually arrive in excellent condition.—Ed.]

esting as being probably the only fern that was ever the subject of legislation, the Legislature of Connecticut having passed a law to prevent the wanton extermination of the fern in that State. This species was figured in the *Agriculturist* for January, 1870. There are several exotic species grown in greenhouses, some of which are exceedingly beautiful and more delicate than ours. One of these we not long ago received from Olm Brothers, Newark, N. J., who raised it from the spores which they received under the name of *Lygodium flexuosum*. As there is much confusion in collections in regard to these climbing ferns, the same thing being found under the name of *L. scandens*, *L. flexuosum*, and *L. volubile*, we can not be sure of the name of the present plant, but think the last given name properly belongs to it. But we are sure of its great beauty, which can not be adequately represented within the limited space of our engraving. Like our native one, the upper and fruit-bearing divisions of the fronds are more delicate than the lower. This fern will grow to the height of six feet or more, and is one of the most graceful greenhouse plants that can be imagined. One of our friends has had it on trial for some

net, *Poterium Canadense*. The stem is from three to six feet high, with rather coarse pinnate leaves, and terminated by a dense spike of white flowers sometimes a foot long. These flowers will be found upon examination to be without any petals, and that the showy part of the flower is the long white stamens. One would hardly at first sight suppose that this belonged to the Rose Family, but its structure places it there, not far from the Spirææ. Although not very showy, this plant might be introduced into the shrubbery, where its long spikes, appearing late in summer, would have a good effect rising above the then generally flowerless shrubs. The botanical name, *Poterium*, comes from the Greek for *drinking-cup*, the leaves of the European species having been used in medicinal drinks. The name Burnet we get in a roundabout way from the French *brunette*, the flowers of the European plant being brownish. In other countries the European Burnet is grown in gardens for its leaves, which have the odor of cucumbers and a spicy taste, and are used in salads and as a flavoring for soup. It is rarely used in this country, except by foreigners, who knew it abroad, but our seedsmen usually keep the seed for sale.

THE HOUSEHOLD.

(For other Household Items, see "Basket" pages.)

Wall Pockets and Holders.

Receptacles of various sizes placed against the wall are often of great convenience in bed-rooms, sitting-rooms, or other parts of the house. These may be made elaborately and costly or of cheap materials, which if well selected often produce as good an effect as the more expensive ones. They are made small enough to hold a watch and large enough to hold newspapers. Those of which we give illustrations are made of pasteboard and covered with inexpensive materials, and finished with ornaments that are easily obtained. Slippers which are only worn during the evening are much in the way the rest of the time unless there is a place for them, and as this place should always be close at hand nothing is more convenient than a

SLIPPER HOLDER to hang upon the wall. It is made of pasteboard, black cloth, ordinary white china buttons, and white beads; is made with very slight expense and trouble, and is more effective than many of the elaborately worked slipper holders. Make the pattern for the back, which it will be observed is a square with a rounded portion below; fold the paper in the middle, so as to cut both sides of the pattern alike. Commencing the curving just at the end of the square, make a cover for the pasteboard, cut after this pattern, of black (or colored) cloth on one side and strong muslin on the other. Make the pocket part of the same materials as shown in the engraving. Sew on the buttons with red silk. The center of the palm pat-

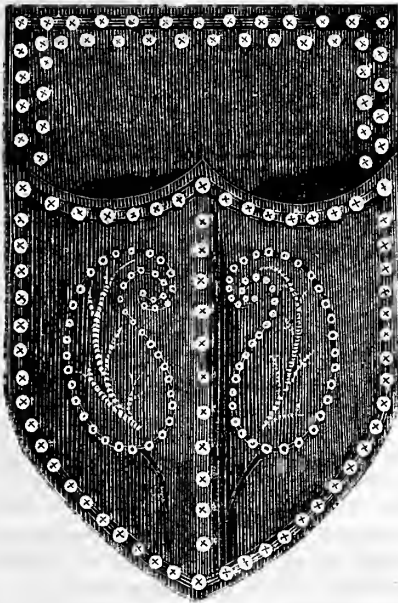

SLIPPER HOLDER.

tern is made by sewing on ordinary white beads, matching the buttons in color. A neat

WALL POCKET, to hold small articles is made thus: Take a square of pasteboard; cover with blue, red, or green muslin; fasten securely on the wrong side. It will be prettier if two sides are braided in some simple pattern. Trim these sides with crochet lace, so as to soften the effect of the edge. Next make a paper pattern for the pocket part by cutting a square larger than the one you have already covered. Take a ruler or any straight edge and draw a line from one corner to the other; cut close to this line. Measure this by placing corner to corner with the covered back, and you will find your half square a little too large at the top. Dot with a pencil how much on each side and draw a line parallel to the first, and cut neatly. Lay this paper pattern on thin pasteboard and cut as accurately as possible. Cover this half square with the same shade of paper muslin; fasten on wrong side securely. Make a cover, which may be taken off

and washed, of white dotted Swiss. Trim with ruffle of white. The edge is simply rolled over and coarsely over-handed with worsted the same shade as the paper muslin, and ribbon bows which orna-

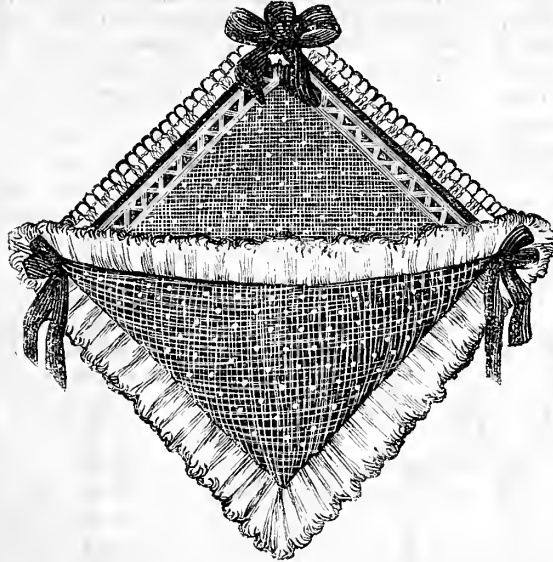

WALL POCKET.

ment the top and sides. The illustrations and descriptions are sent by Miss A. Donlevy.

"Sweet Home."

Have you seen the ideal home? Let me try to describe it. It is the place where all ("all" may be only two individuals, or it may be more) unite to give security and freedom and help and sympathy to each; where each feels free to act out himself in any way that does not interfere with the welfare of any other; where each is sure of sympathy in his joys and sorrows and plans; where each feels bound, by bonds of affection which are only perfect freedom to the wise, to lend a helping hand to any other member of the home who is in need of any kind of help that he can give; where the golden rule is the law of daily action because the law of love is written on all hearts.

No, I have never seen the ideal home as I have described it here, except in brief glimpses, and yet I do know something of it. I doubt whether any one lives, in the present somewhat chaotic state of human nature, who has constantly such a home, at least in its outward aspects. There may be—yes, I believe that there are—such homes carried about in the hearts of some fortunate ones who truly love each other, and love the Highest and Best supremely. There are those who know internally all about "sweet home," know it by a kind of revelation from above, who have lives of outward hardship and sorrow, perhaps have not even a place to lay their heads.

How near to this ideal standard of safety and freedom and joy can we bring our actual homes? That is a question for all home-makers to study. Women are home-makers, but so are men. It can not be a true home where the service is one-sided, where only one tries to bear "one another's burdens." Each must do and bear a part, though the stronger and wiser ones can do and bear the most.

Do they? No; in many a place called "home," but never truly such, they who are strong use their strength to compel the service of the weaker ones; they who imagine themselves superior in wisdom prove their folly by exacting signs of reverence from those they consider their inferiors because of age or sex or some kind of personal difference, while they allow their own rudeness, and selfishness such license among the defenseless members of their own family as they would not venture upon anywhere else.

The perfect home, in outward aspects, is hardly possible yet, because we are still so imperfectly christianized. We are all linked together, good and evil, wise and foolish, healthy and sick. They

who grovel keep those down who try to rise. They who try to raise themselves find that they are burdened by the weight of all mankind below them, and that the truest way to help themselves is to set to work to help everybody else. The spirit of caste and the true home spirit never harmonize. You sing the praises of home and the family, and then look about for the reality of that which your fancy pictures. You find that the bare struggle for an existence—for food and clothes and shelter—consumes all of the time and strength of a large proportion of our fellow-men; that the little children scarcely get a chance to see their fathers; that the fathers and mothers are so weary and care-worn when evening comes that any interchange of thought except upon the cares and anxieties of their position and the foolish neighborhood gossip seems impossible. Then there are homes where wealth abounds, but you see the inmates worried by the cares that wealth entails and by the incompetency and unfaithfulness of those they employ to do their work. Ignorant servants—"servants" of any kind in the usual sense of that word—mar the harmony of home. Private family selfishness is the lasting bane of our present style of home. How soon

shall we be able to bring Bridget and all her class within the influence of the co-operative spirit? How soon shall we be able to unite our home interests sufficiently to allow us all some chance to draw a free breath? When we shall have made moral and spiritual progress enough for this a good many evils which seem each to call for a special class of "reformers" will settle themselves, so to speak.

FALL.

What Shall we Have for Breakfast?

BY MRS. ELLEN E. BONDAM, OXFORD, O.

Last month we gave an answer to this question from a lady in Louisiana, and we now give another, this time from Ohio, with recipes for preparing such dishes as the writer considers not generally known or for which her manner of making them may be peculiar. She writes:

"In preparing a bill of fare for breakfast for one week I have selected such articles as most farmers' wives can command, and such as I am in the habit of setting before my own family. Most of the dishes are wholesome and easily prepared, and a breakfast from any one of these bills of fare can be made ready in forty-five minutes."

Bill of fare for breakfast for one week:

SUNDAY.—Beefsteak. Hashed potato. Fried mush. Baked apples. Cold bread, coffee, and such fruit as is in season accompany each breakfast, and need not be repeated.

MONDAY.—Broiled ham. Potato balls. Graham gems.

TUESDAY.—Sausage or mutton chops. Fried potatoes. Corn dodgers.

WEDNESDAY.—Breakfast bacon or corned-beef hash. Baked potatoes. Shirred eggs. Corn bread. Pickles.

THURSDAY.—Veal cutlets. Boiled potatoes. Butter-cakes or milk toast.

FRIDAY.—Ham toast, and Graham bread. Potatoes pared, sliced, and boiled in just water enough to cover them. Pickles.

SATURDAY.—Codfish balls. Boiled eggs. Fried rice or baking-powder biscuit.

HASHED POTATOES.—Chop cold boiled potatoes as for hash. Moisten with milk, add butter and salt to taste, and heat in a skillet.

GRAHAM GEMS.—One heaping pint of Graham flour, one scant pint of cold water, and one-half tea-spoonful of salt. Heat the gem-pans, grease, and fill even full with the batter. They will bake in thirty minutes in a quick oven.

CORN DODGERS.—Scald the corn-meal, add salt and cold water, having the batter as stiff as mush.

Bake in gem-pans. If milk is used instead of water they will brown more quickly, but are no better.

SHIRRED EGGS.—Heat a little butter in a pie-pan, then put in the eggs, taking care that the yolks are not broken, and bake in the oven.

CORN BREAD.—One pint of buttermilk; one heaping pint of meal; one even tea-spoonful of soda; two eggs.

HAM TOAST.—Chop cold boiled ham; add milk to soften a sufficient quantity of toast; add butter, and season to taste. After dipping the toast, and just before dishing, stir in two or more eggs. As soon as it begins to thicken pour over the toast.

GRAHAM BREAD.—Two tea-cupfuls of buttermilk; two tea-cupfuls of sweet milk; one-half a tea-cup of molasses; one tea-spoonful of soda; salt; and Graham flour to make a stiff batter. Bake in gem-pans.

FRIED RICE.—Take cold boiled rice, stir in an egg, and drop by the spoonful on a hot griddle.

Concerning Medical Matters.

A lady in Illinois writes that she sent us several months ago some recipes that she had found exceedingly useful in her family, and wonders that we have not published them. In respect to medical matters we have some very positive opinions—one of which is that there is far too much medicine taken for the good of the people, and that, so far as we are concerned, we shall do nothing towards inducing our readers to dose themselves. Physicians are far in advance of the people in this respect; they do not give one-tenth part of the drugs they did twenty-five years ago, and were it not that their patients would not be satisfied if they did not "do something," they would give still less than they do now. A sick person needs to have his mind treated as well as his body, and if he feels that something is being done for him his mind is at ease, and he will not fret about himself. So a physician really does him a benefit by leaving some harmless thing, to be taken in exact doses every few hours—the oftener the better, as it will occupy the mind in looking out for the precise time. Every physician knows that while the patient's view of his services is confined to the medicine given, his trouble is to find out exactly what is the matter, and how far nature is tending to repair damages. If matters are going on well enough, and if not interfered with, nature will effect a cure; all he has to do is to amuse the patient with harmless doses. If he were to say, "there is nothing serious the matter with you; you have only to keep in bed and feed on slops, and you will be well in a week," that doctor would be discharged, and one sent for who would "understand the case and give something to cure it." The mental effect of the visits of a cheery doctor is of great help to patients who are not especially ill, and his services in this respect are worth all they cost. Now, we do not mean to say that there are no cases that need medicine, for there are many in which life may depend upon the most prompt and energetic treatment; but what we wish most especially to enforce, is the fact that when there is any serious illness no one who has not been educated to the matter can make a proper *diagnosis*, which is the medical term for finding out what is the matter, and is the most difficult thing to do; if this be not correct the treatment may be useless, or even harmful. It would be folly for us to publish remedies for particular maladies when it is almost impossible for other than a physician to know whether such diseases are present or not. We do not wish to convey the idea that a physician should be called for every minor ailment; colds, irregularities of the stomach and bowels, local pains, and other such ills can be treated with the domestic remedies at hand. Every family keeps a few simple remedies, which vary according to usage; but there should always be at hand, especially in farm-houses—something to make a warm drink to promote perspiration, some cathartic or laxative to move the bowels, some astringent, and

anodyne, and in fever and ague districts quinine or such other antiperiodic as is known to be useful. For the rest the kitchen may be depended upon for soda as an antacid, salt to check vomiting, cayenne pepper as a stimulant, and mustard, one of the most useful of applications for local pains. When an illness does not yield, and promptly, to these domestic remedies do not hesitate about calling a doctor. The pain in the stomach or bowels that does not yield to a mustard plaster and a few doses of paregoric or laudanum may be a symptom of some serious disease of those parts that requires an entirely different treatment. A sore throat with a pain not relieved at once by the usual remedies may indicate the severe and often fatal diphtheria, and a continued and increasing looseness of the bowels may be a symptom of something more serious than an ordinary diarrhoea. Every sensible mother will, the moment that she is not sure she is right, call in the services of some one who knows more than she does. Delay may be dangerous. We think that those papers who under the head of a "Hygienic Department" publish all sorts of remedies and recipes do more harm than good. Hygiene has very little to do with dosing. We may here perhaps properly answer questions which have been proposed probably a hundred times in one form or another—that is, if in our denunciations of all secret remedies, patent or proprietary medicines, we would not exempt this or that particular one which the writer has tried and found useful. No; we do not except one. A large portion of these are frauds, being mere stimulants of the cheapest sort. Others are medicinal, but there is not one of them from beginning to end that is composed of any other than well-known drugs. No; we object to all these things put up in bottles and labelled, for the reasons that you do not know what you are taking, and that you are paying an enormous price for some cheap drug—fifty cents or a dollar for what could be bought for five or ten cents, simply because it is put up in a bottle with a showy label, and called somebody's "balsam," "panacea," or what not. The hundreds of babies that have come to their untimely deaths from the use of "soothing syrups," which the mothers did not know contained deadly quantities of morphine, should be a sufficient warning against secret compounds. Our friends who have sent us recipes for what they consider "the best thing in the world" for this or that disease, must excuse us if we do not publish them. It is a little curious that most persons recommend any remedy as "the best thing in the world," while their knowledge of the world is exceedingly limited.

Minor Hints and Notes.

A CAREFUL LAUNDRESS can always be known by one sign. It is not the smoothness or polish of the bosoms and collars, but by a minor matter. Does she iron out strings? There is nothing more annoying than to have a tape used as a string to drawers or elsewhere rolled and twisted into a cord. All good ironers make them flat and as good as new.

CANDIED HONEY.—The candying of honey is due to a part of the sugar becoming crystallized. The honey is just as good and as pure as ever, but not quite so pleasant to eat on account of the small grains of sugar. There is no way known to prevent this, and the best honey, that made from clover early in the season, is more apt to be candied at the present time than the later made. By placing the bottle or jar containing the honey in a vessel of water, with sticks under it to keep it from direct contact with the bottom of the vessel, and gradually heating it, the sugar will be dissolved and the honey become clear, and last in that condition a greater or less time, according to the temperature at which it is kept. If it should become candied again the heating may be repeated.

ARE PLANTS IN ROOMS UNHEALTHFUL?—We have answered No a number of times, but the question still comes, probably from new subscribers. The atmosphere of a greenhouse crowded with plants has been analyzed, and found to be not

essentially different from ordinary air. If it were unhealthy to breathe the air in which plants were growing we who live in the country should show it, and those who during summer camp out in the woods would hardly find the health they seek. There is no danger in sleeping in a room with plants. A whole roomful can not affect the air nearly as much as an additional person or the burning of a night-lamp. The fact that certain odors of flowers are unpleasant to persons particularly sensitive to such things is another matter. It is usually a case of individual peculiarity, and easily remedied by removing the offending plant.

BLACKING IRON-WORK.—"S. M. T." If the iron-work is not to be exposed to heat you can have nothing better than shellac varnish and lamp-black. We have before given directions for making the varnish, which are in brief: In a wide-mouthed bottle put shellac with sufficient strong alcohol to cover it. Put this in a warm place, or in a vessel of water with something to keep the bottle from touching the bottom of the vessel, and heat the water gradually; the shellac will soon dissolve. If the varnish is too thick add more alcohol. For black, put some lamp-black in a cup, wet it thoroughly with alcohol, and add some of the varnish and mix. This is to be used on the iron-work as paint. Put on another coat if needed. This black varnish dries bright on metals, but on wood or other surfaces the first coat will sink in and be dull, and the application must be repeated. If wanted very smooth polish with a flannel and a very little sweet oil. Other colors that are not very delicate can be used in the dry state with the varnish, which is a handy thing in the house.

IN KEROSENE LAMPS the light often is unsatisfactory while all is apparently in good order. It should be borne in mind that, though the wick is but very gradually burned, it is constantly becoming less able to conduct the oil. During several weeks some quarts of oil are slowly filtered through the wick, which stops every particle of dust or other matter that will with the utmost care be in the best kinds of oil. The result is that the wick, though it is of sufficient length and looks as good as ever, has its conducting power greatly impaired, as its pores, so to speak, or the minute channels by which the oil reaches the place to be burned, become gradually obstructed. It is often economy to substitute a new wick for an old one, even if that be plenty long enough to serve for some time to come.

A Netherland Breakfast.—R. Van Oosterhout, Scott Co., Minn., writes: "I contend that the most wholesome breakfast is made of Java coffee, filtered, with cream and sugar added to the taste. A slice of white and Graham bread each, lightly buttered with good sweet butter, and a little grated or sliced cheese between. The dose repeated if needed. It is the national breakfast of the Netherlanders."

JOHNNY-CAKE WITH EGGS.—Two cups of sweet milk; half a tea-spoonful of salt; one table-spoonful of sugar; two eggs well beaten; a small tea-cup of white flour mixed with a tea-spoonful of baking-powder, and corn-meal enough to make a batter. Sometimes I begin with the meal and scald it, and then use only one cup of sweet milk and no baking-powder, with no definite proportion of white flour—enough to make the batter right. The batter should always be thicker when the meal is scalded than when it is not, because in the latter case you must allow for the meal to swell some. Of course, the milk should be added to cool the scalded meal before the eggs are put in, or the hot mush would partially cook the eggs.

PARADISE CAKE.—Three eggs; one cup of butter; two and a half cups of sugar; one and a half cup of sweet milk; a small teaspoonful of soda; four large cups of flour; one pound of raisins; cloves, cinnamon, and nutmeg.

BOYS & GIRLS' COLUMNS.

The Doctor takes the Boys to a Match Factory.

"Uncle," said one of the boys, as the match with which the evening lamp was lighted went off with a snap and a fizz, "how are matches made?" "That depends upon the country," I replied. "In some Indian countries the young man ties a horse near the hut of the

something that will take fire readily and burn long enough to set fire to it. For the cheaper matches sulphur is used, but for what are called parlor matches they use paraffine, which burns without any unpleasant odor. "What is paraffine?"—"It is one of the many things obtained from petroleum; it is a solid white body that looks much like white wax; it burns with a very brilliant light, and is used for making candles." At the time of our visit they were making sulphur-dipped matches, but the operation is the same with paraffine. The material is melted in a large vessel, and the roll of

more difficulty than they should. After it is well mixed, the sticks that have had their ends covered with sulphur or paraffine are dipped in it in the same manner as at the first dipping, only care is required to have but a small quantity of the mixture just at the very tips. The next step is to dry the matches, and they are taken to a room where they are placed upon racks; here there is a fan rapidly revolving, so as to constantly change the air and gradually dry the composition upon the ends of the matches. They are not allowed to become so dry that they will readily take

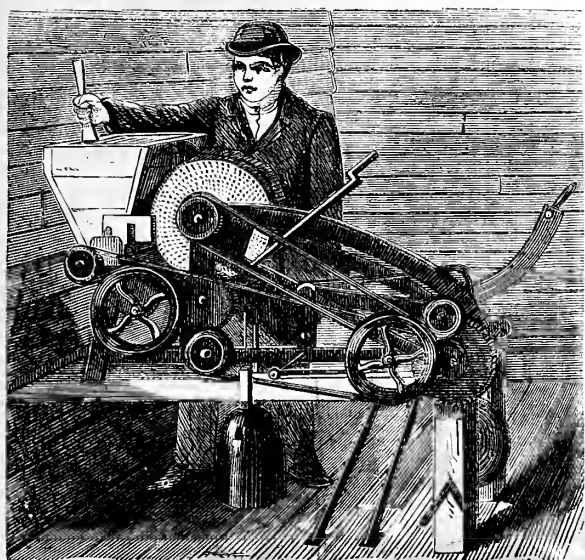

Fig. 1.—MAKING THE STICKS INTO ROLLS.

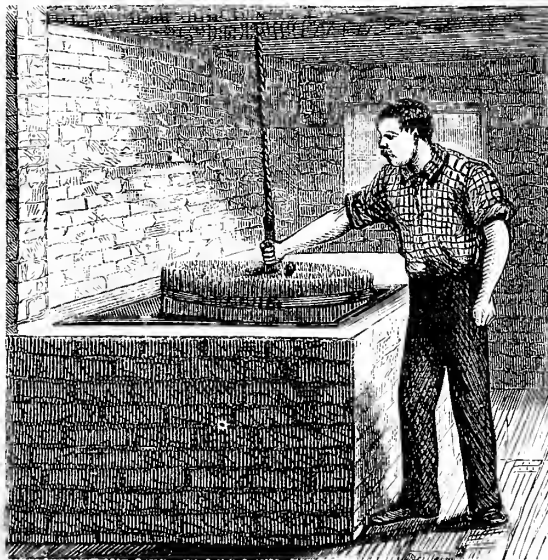

Fig. 2.—DIPPING IN SULPHUR.

fire, as they have still to go through another machine, and if they were perfectly dry, disagreeable accidents might happen. Thus far the matches are in pairs, or "double headers"—twice the length of one—and they have to be cut apart. For this they are put into a cutting machine (fig. 5), which unrolls the bundle and carries the sticks over a knife which rapidly cuts them in equal parts, and the now complete matches slide into boxes on each side of the machine. All that remains to be done is to pack them in the proper boxes.

The boys left the factory feeling that their curiosity about the making of one kind of matches, at least, was satisfied. I asked Art what part of the operation interested him most. He said, "The machines that made the match sticks up into rolls and cut the sticks apart. Why, they did their work just as if they could think." "I know why," said Wat; "the man who invented them put lots of think into them."—"A very good idea, Master Walter," I suggested, "but it would be much more proper to say, 'they embodied a great deal of thought.'"—I am not sure, but I heard him remark in an undertone, "He has forgotten his boys' talk."

maiden, and if she feeds and waters it, the owner is accepted; but if the horse is left without care for three days, he is— Then there was a shout. "What a provoking old uncle! You know we don't mean that kind of matches, but the kind with which we strike a light." I promised to take them to the city next Saturday, where there are several match factories, the proprietor of one of which I knew. At the proper time, Wat, Art (as we abbreviate Walter and Arthur), and myself found our way to the place where matches are made. "What I want most to see," said Wat, "is the way in which all those nice round sticks are whittled out. I should not think a man could make sticks for many boxes of matches in a day, if he had ever so good a knife." The proprietor smiled as he informed the boy that the sticks were not made by whittling, nor were they made at the factory. The sticks are brought from Canada, where the making of them is a separate business. They are made by machinery which drives a block of wood upon a steel die that has numerous small holes in it. The wood is forced through these holes in the rounded form of the match sticks. They are twice the length of an ordinary match, and come packed in boxes. The first thing to be done with the sticks is to arrange them so that large numbers can be handled at once in dipping the ends in the mixtures that cause them to light readily. If the sticks were simply tied together in bundles, they would be too close together, and the composition would be all in one mass upon their ends, so a machine had to be invented which should make them into rolls and still keep the sticks a little distance apart. This machine (fig. 1) did its work with wonderful rapidity and accuracy; the sticks were applied to the machine which made them into

sticks so suspended (fig. 2) that the ends can be evenly and slightly dipped in the melted sulphur. Both ends are dipped, and they are then ready to receive the composition that takes fire when the match is rubbed. The principal thing in this composition is phosphorus, which the boys saw, looking like sticks of barley candy in a bottle of water. Finding it had to be kept under water to prevent it from taking fire, and that it was a very curious substance in other respects, I had to promise to tell them more about phosphorus and sulphur when we got home, as we could not now take up the time of the proprietor of the match factory. Although pure phosphorus takes fire so readily, it may be so mixed with other things as to require to be strongly rubbed before it will burn. It melts readily, and may be mixed while in the melted state with these things, if care be taken to keep it covered from the air. We learned that different makers of matches use different mixtures for

say, 'they embodied a great deal of thought.'"—I am not sure, but I heard him remark in an undertone, "He has forgotten his boys' talk."

Aunt Sue's Puzzle-Box.

DECAPITATIONS AND CURTAILMENTS.

1. Behead "to starc" and leave an animal.
2. Behead a bird and leave "to agitate."
3. Behead a poet and leave a Hebrew measure.
4. Curtail an herb and leave "to lean."
5. Curtail a bird and leave a distinguished man.
6. Curtail a vegetable and leave an insect.

ITALIAN BOY.

CROSS-WORD.

My first is in marble but not in flint.



Fig. 3.—MAKING THE MIXTURE.

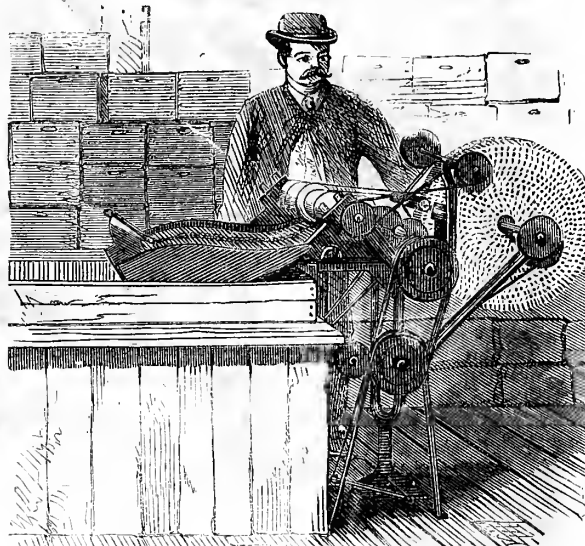

Fig. 4.—CUTTING THE MATCHES APART.

large rolls, and with a belt of cloth between the layers of sticks; this cloth keeps the sticks just a little distance apart. When the bundle is large enough, some two feet across, it is bound securely and then taken to another room. "What a smell!" exclaimed both the boys at once, as we entered the room. "It is not very pleasant to strangers," said the proprietor, "but we who are here every day do not notice it." We learned that the composition upon the ends of matches does not burn long enough to set fire to the stick, and that before that is applied it is necessary to prepare the wood with

their composition, but all of them have phosphorus as the principal thing. Some have chlorate of potash in them, a substance that in some respects is a good deal like saltpeter. The phosphorus is mixed with dissolved glue, and whiting or some other powder to make a paste, and coloring stuff is added. The whole, after being stirred over a fire (fig. 3), is put into a machine where it is more thoroughly mixed. It is very important that the composition be well mixed, as otherwise some matches will get more, and some less phosphorus than they ought to have, and will go off too easily, or with

My next is in thyme but not in mint.
My third is in glove but not in mit.
My fourth is in humor but not in wit.
My fifth is in room but not in house.
My sixth is in rat but not in mouse.
My seventh is in pretty but not in good.
My eighth is in splinter but not in wood.
My ninth is in tress but not in curl.
My tenth is in emerald, not in pearl.
I hope, with all my heart and soul,
You'll never suffer with my whole.

SQUARE-WORD.

1. A city. 2. Apart. 3. Above. 4. Notions. 5. Meaning. "SWEET P."

NUMERICAL ENIGMA.

My whole is a word of six letters, and is indispensable in the formation of good habits.
My 2, 5, 1, 3, 4, 6 is an unenviable emotion.
My 3, 4, 6—2, 5, 1 is worn as an insignia of office.
My 6, 4, 5, 3, 1, 2 is one form of destitution. E. S. B.

ARITHMETIC.

- | | |
|----------------------|------------------|
| 1. 200050500. | 5. 40001900400. |
| 2. 4005010. | 6. 110016010900. |
| 3. 5001601016015250. | 7. 900110250. |
| 4. 15080150. | 8. 100017250. |

O. A. GAGE.

ALPHABETICAL ARITHMETIC.
YAYHYTATLRTYIC
HHRC

CHT
ECT
YSL
YLTT
YERR
YSSR
YSL

GEOGRAPHICAL HOUR-GLASS.

1. A strait of Asia.
2. A city in Massachusetts.
3. A city in Scotland.
4. A lake in Asia.
5. A city in France.
6. One-fifth of an ounce.
7. A river in Russia.
8. A lake in Russia.
9. A sea of Asia.
10. A town on Long Island.
11. A city in New Mexico.

The central letters, read downwards, give a lake in North America. BEAU K.

PI.

A draw cone kenpos ton anc eb hugtorb kabc yb a chaco dan rofu. A. W. P.

ANSWERS TO PUZZLES IN THE JANUARY NUMBER.

ANAGRAMS.—1. Antiquity. 2. Espousal. 3. Subaltern.

PI.—Every one's faults are not written on his forehead.

NUMERICAL ENIGMA.—Hippopotamus.
CONCEALED TREES AND FLOWERS.—1. Balsam. 2. Olive.
3. Peony. 4. Elm. 5. Linden. 6. Ash.

DOUBLE ACROSTIC.—C-ivi-C
R-nle-R
O-ntd-O
S-tre-W
S-ire-N

SQUARE-WORD.—BLIND
LEVER
IVORY
NERVE
DRYER

(R. S. Smith is the only one who sends a solution to this.)

Thanks for letters, puzzles, etc., to Mary C. S., F. M. Priest, Elkcin, Ira W. B., R. S. S., and others.

Performing Bears.

Bears, great clumsy fellows as they are, have no little intelligence, and they are capable of being taught various tricks. Among the street shows of large cities it is not rare to see bears who have been trained to go through various performances. The engraving represents a scene which one of our artists saw in the street some time ago. Among other things that the animals had been taught to do, one had the accomplishment of standing on his head, while the other would uncork a demijohn and take a drink from it, much to the amusement of the bystanders. We never see bears thus treated but we wish they might get away to the wilds where they belong. To be muzzled and led about from place to place and made to perform what are no doubt very unpleasant antics, and probably to be beaten, is indeed a great change from the free life to which they were born. There used to be a bear at one of the public gardens near New York which was quite a good customer to the proprietor's bar. The bear was exceedingly fond of soda water, and visitors would buy bottles of it to give to the bear for the sake of seeing how handily he

named a boat which he fitted up with a very rude engine. Those who have been to New York city have no doubt seen the great stone prison called "The Tombs." Where this stands there was in the early days of the city a large pond called the Collect, from which a small stream ran through what is now Canal street to the Hudson River. It was upon the borders of this pond that Fitch fitted out his boat, and it was on its surface that moved, so far as is known, the first vessel propelled by steam. The boat is described as a very rickety affair, which would move off for a few minutes and then it would stop until more steam could be made. The engraving made from an old model shows how the boat looked. It does not seem to have attracted a great share of attention, and finally the boat went to decay and was carried off in pieces by poor people to burn. It is said that Fulton was present while Fitch was making his experiments, and if this were the case he no doubt profited by his failures. Fulton has the credit of having first propelled a vessel by steam, as he was the first who put the idea to practical use; the same as Morse by his inventions made the telegraph practical. Telegraphs had been experimented with in a small way before Morse made his, but they were of no real value until Morse took the matter in

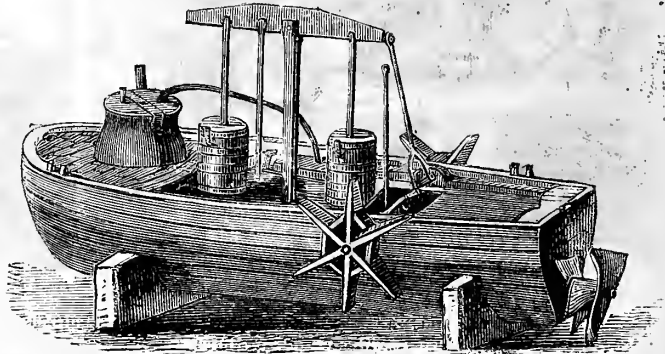

THE FIRST STEAMBOAT.

hand, and to him justly belongs the credit. An important invention is rarely the work of one person alone; many fail, but we hear only of the successful one.

Carrying a Ladder.—Did you ever see a person

carry a ladder? He puts it on his shoulder, or it may be puts his head between the rounds and has one of the sides resting on each shoulder, and having it nicely balanced walks along. A man with a ladder is an interesting object in a crowded street. He looks at the end before him, but the end behind him he can not see. If he moves the front to the right end to get out of the way of a person, away goes the rear end just as far in the opposite direction, and the slightest turn of his body, only a few inches, will give the ends a sweep of several feet, and those in the way may look out for bruised hats and bumped heads, while the window glass along the street is in constant danger from the unseen rear end of the ladder. When a small boy, I was carrying a not very large ladder, when there was a crash. An unlucky movement had brought the rear end of my ladder against a window. Instead of scolding me, my father made me stop, and said very quietly: "Look here, my son, there is one thing I wish you to always remember; that is, every ladder has two ends." I never have forgotten that, though many, many years have gone, and I never see a man carrying a ladder or other long thing but what I remember the two ends. Don't we carry things besides ladders that have two ends? When I see a young man getting "fast" habits I think he sees only one end of that ladder, the one pointed towards pleasure, and that he does not know that the other end is wounding his parents' hearts. Many a young girl carries a ladder in the shape of a love for dress and finery; she only sees the gratification of a foolish pride at the forward end of that ladder, while the end that she does not see is crushing true modesty and pure friendship as she goes along thoughtlessly among the crowd. Ah! yes, every ladder has two ends, and it is a thing to be remembered in more ways than one.

UNOLE CARL.

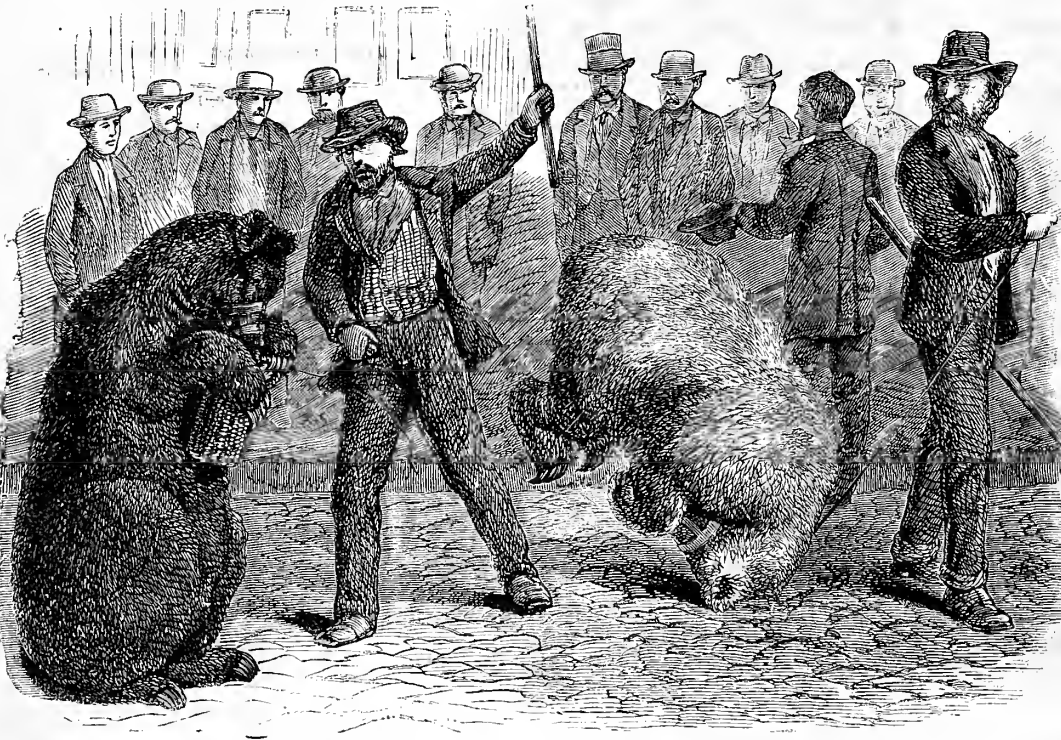

PERFORMING BEARS.

4. Remedial.
5. Confiscated.
6. Remembrance.
7. Incoherence.
8. Colonnades.
9. Interpretation.
10. Earnestness.

CROSS-WORDS.—1. Buffalo. 2. Money.

DIAMOND PUZZLE.—
R
EEL
REFER
LEE
R

would undo the fastening to the cork and swallow the contents of the bottle without spilling a drop.

The First Steamboat.

Who built the first steamboat? All the smart scholars will probably answer at once "Robert Fulton." And the smart scholars would all be wrong, for the first steamboat was built in 1796, while Fulton did not build his until 1807. One John Fitch built in the year first

It was not a very well-read farmer who told the sewing machine agent, who solicited him to purchase, that he did not want any of "them air machines," as his wheat came up well enough when sowed by hand.

Life Insurance.

NONE is less respected than the man who muddles away his income nobody knows how. For all expenditure there should be something to show, and that something ought to have either usefulness or dignity or permanence to recommend it.

But every now and then we meet with cases of expenditure actually mysterious. A man of princely inheritance or preferment does nothing with it, makes no figure, helps nobody, maintains no expensive state, yet not only spends every dollar of his income, but is in continual embarrassment and difficulty. His estate crumbles away, his house grows dilapidated, his equipments shabby, his creditors clamorous, and at last he dies, leaving his sons penniless and his daughters homeless. Instead of performing his part in sustaining the great fabric of society as far as his influence and opportunity enable him to do so, there is one vast dilapidation.

Nobody can say exactly where the fault is or where the money is gone. It has not benefited friends, assisted dependents, built school-houses, tilled the soil, developed the country, beautified the town, or done anything that can be set down to his credit. It has all been dribbled and frittered away on hollow pretenses and petty occasions and trivial objects, without either system or purpose. It has won neither gratitude nor admiration nor respect. The only useful thing the man does is to fertilize the earth by rotting in it.

How mean does such a life appear! How unworthy of the name of life! And yet how many human lives are lived to no better purpose, and leave behind them no more creditable results!

The sin of this aimless, empty prodigality lies at other doors as well as those of the rich. Moderate and even scanty incomes can be made to contribute something permanent to the fortunes of their recipients. But it is the men of small means and moderate incomes who are most sadly at fault in respect to that useless expenditure of which we are speaking. It is not extravagance, because such can not be extravagant. It is a slippery habit of expenditure, which justifies itself with the unspoken apology: "I can never save anything. My effort to do so would be contemptible and vain. Why then attempt it?"

But there is no man of howsoever moderate income, or howsoever small means, who can not at least leave his family the better for his having lived. The savings of a little economy, the small self-denials that can be made every day, and in the making of which manhood grows to a tougher fiber and a statelier height—these will suffice to leave to the mother and her little ones a legacy that will lift them above want and the fear of want.

Life insurance is the only means known whereby this can be surely done; and in this light life insurance is seen to be a duty that no true man can excuse himself in neglecting. It is frequently and warmly commended, but it can not be commended too often nor with too much warmth. It is the moral duty of every man to bequeath to his children more money than he began life with himself. Life insurance alone enables him to do this beyond peradventure.

Many are the companies appealing to the public for patronage. Most of them are good; and among the very best is the United States Life Insurance Company of this city. It is secure; it is liberal; it is progressive; it is honorable. Nearly a quarter of a century has tested it, and each year has borne increasing witness to its stability and its worth.

Breech-Loading Shot-Guns of all the celebrated makers—**Sturtevant's Patent Brass Shot Shell.** Shooting Tackle of every description. Send for Descriptive Catalogue. **SCHUYLER, HARTLEY & GRAHAM,** 19 Maiden Lane, New York.

MAINTH BRONZE TURKEYS and **POULTRY.** D. L. REED, Atburn, Ohio. Circulars free.

A CURIOSITY on page 113. Read it, and send for one.

(CIRCULAR.)
Consumers Importing Tea Co.,
No. 8 Church Street,
P. O. Box 5,509. New York City.

This is a combination of capitalists to supply the consumers of Teas throughout the United States on the mutual principle.

We have experienced agents in all the best districts of China and Japan to select Teas especially for our trade.

We expect every consumer of Teas to render us all the assistance they can in carrying out our enterprise, as we make a specialty of SUPPLYING CONSUMERS ONLY (and allow no middlemen to make any profit on our importations), which will enable us to supply them with Teas at prices lower than have ever been known, and of those fine qualities that seldom reach the interior, being sold only in the large cities and among the very wealthy.

Hoping the consumer will take an interest in our enterprise, and send at once for a circular with full explanations of how to proceed to obtain our goods, we remain,

Most respectfully yours,

Consumers Importing Tea Co.,
No. 8 Church Street,
P. O. Box 5,509. New York City.

Entered, according to Act of Congress, in January, 1874, by the Consumers Importing Tea Co., in the Office of the Librarian of Congress, Washington, D. C.

GREAT DEDUCTION.
TEAS and COFFEES

At Wholesale Prices.
Increased Facilities to Club Organizers.
Send for New Price-List.

THE GREAT AMERICAN TEA COMPANY,
(P. O. Box 5643.) 31 and 33 Vesey St., New York.

SEEDS
OUR BEAUTIFULLY ILLUSTRATED
CATALOGUES for 1874. of
SEEDS AND PLANTS
Numbering 175 PAGES, and containing 2 fine large colored plates, are now ready. To our patrons they will be mailed as usual free, to all others, on receipt of 25c, which we return in Seeds or Plants, with first order. All purchasers of our Books, either for Gardening for Profit, or Practical Floriculture, Price \$1.50 each (prepaid by mail), have their names entered on our lists, and will receive above Catalogues annually, free of charge.
Peter Henderson & Co.
Seedsman, 35 Cortlandt Street, New York.
PLANTS

CHOICE SEEDS.
Market Gardener's Stock
FOR EARLY PLANTING.

Fottler's Brunswick Cabbage.....	Per oz., 75c.	Per pkt., 15c.
True Jersey Wakefield do.	" 75c.	" 15c.
Boston Market Dwarf Celery.....	" 50c.	" 10c.
Hotbed Lettuce.....	" 50c.	" 10c.
White Spined Hotbed Cucumber..	" 50c.	" 10c.

Our new Seed Catalogue for 1874 will be ready February 1st. Free to all applicants. Address **SCHLEGEI, EVERETT & CO.,** 16 South Market St., Boston, Mass.

Erianthus Ravennae.

A 25c. pkt. of seed of this splendid Ornamental Grass will be given to all who send 3-cent stamp for my Spring Catalogue of Plants, etc.
CHAS. T. STARR, Avondale, Chester Co., Pa.

SEEDS.
TRADE LIST for dealers only mailed to all applicants. Address **KERN, STEBER & CO.,** Seedsman, St. Louis, Mo.

NATIONAL LIVE-STOCK JOURNAL,
PUBLISHED AT CHICAGO. Devoted exclusively to Stock. For Breeders, Farmers, etc. \$2. a Year. Clubs of Ten with extra copy, \$15. Specimens Free. **Geo. W. East & Co.,** Publishers.

GEO. A. PRINCE & CO.
ORGANS & MELODEONS.

The Oldest, Largest, and Most Perfect Manufactory in the United States.

53,000

Now in use.

No other Musical Instrument ever obtained the same popularity.

Send for Price-Lists.

Address

BUFFALO, N. Y.

Send for The PIONEER.

I hear the tread of pioneers
Of nations yet to be;
The first low wash of waves where soon
Shall roll a human sea.

A handsome illustrated paper, with information for the PEOPLE, mailed free to all applicants. Address

C. F. DAVIS,

Land Commissioner U. P. R.R.,

OMAHA, NEB.

"The Best Article in the Market."—*Am. Institute Report, 1873.*
ASBESTOS ROOFING
H. W. JOHNS, 37 Maiden Lane, N. Y.
Patentee and Sole Manufacturer. Established 1838.

THE TESTIMONY OF ALL.
SILVER TIPPED

The only Shoe for children.

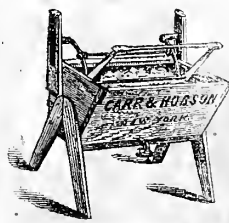

"BEEBE"

Has an unexampled record—not a machine of hundreds sold ever having failed to give perfect satisfaction. It is the only truly faultless hand washer in existence. Finishes the work entirely without supplementary labor, and never wears or tears the clothes. Cheap, convenient, handsome, and made to last a lifetime. Price \$15.00. **CARR & HOBSON,** Sole Proprietors, 56 Beekman St., N. Y.

GRAPE - VINES
OUR SPECIALTY.

Price-lists for Spring, 1874, gratis. Correspondence solicited. Address **ISIDOR BUSH & SON,** Duellberg, Mo.

CHEAP FLOWERS for all. See our advertisement, p. 111 in this paper. **W. L. Ferris, Jr., & Co.**

Farmers and Mechanics, do you
Want the Best Boot or Shoe?

RUY GOOD

CABLE SCREW WIRE MADE

MONEY MADE RAPIDLY with Stencil and Key Check Outfits, Catalogues and full particulars free. **S. M. Spencer,** 117 Hanover St., Boston, Mass.

D. M. FERRY & CO'S
 ILLUSTRATED DESCRIPTIVE PRICED CATALOGUE OF VEGETABLE AND FLOWER SEEDS
 Will be mailed FREE to all applicants. This is one of the largest and most instructive Catalogues published. It is printed on tinted paper, contains 220 pages, over 200 illustrations of Vegetables and Flowers, a beautifully colored plate, and is invaluable to Farmer Gardener and Florist.
 Address, **D. M. FERRY & CO.,** Seedsmen and Florists, DETROIT, MICH.

Seed Time Cometh!

The twenty-first editions of our illustrated FLOWER and KITCHEN GARDEN DIRECTORIES for 1874, with a Supplement of Novelties and Selections, embracing a list of Seed grown by the best Boston Market Gardeners and also by the most famous European growers of flowers and vegetables, including many that can rarely be found elsewhere, will be forwarded about the first of February to all customers free of charge, and to other applicants inclosing a three-cent stamp.

- D. T. CURTIS & CO.,** 161 Tremont St., Boston, Mass.
 Successors to CURTIS & COBB.
SEED FOR EARLY FORCING.
 TOMATO, *New Early Dwarf*, fine for small gardens— $\frac{3}{4}$ pkt. 25c.
 TOMATO, *Canada Victor*, a superior productive early var.— $\frac{3}{4}$ pkt. 25c.
 TOMATO, *The Arlington*, bright red, solid, and fine form—per pkt. 25c.
 Boston Market Tennis Ball Lettuce— $\frac{3}{4}$ oz. 75c.; 15c. $\frac{3}{4}$ pkt.
 White Spined Cucumber, improved—50c.; 15c.
 Long Frame Cucumbers, High'd Mary and Hallstone, each 25c. per pkt.

THE BEST TOMATO



Early, Solid, Enormously Productive, and of excellent flavor. Is a cross between the *Early Smooth Red* and *Feejee*. Fruit of perfect form, smooth, bright red color, very solid, having small seed cells, and no hard core at the center, being of the same delicate texture and brilliant color throughout. Ripens with the earliest. Fruit often weighing 24 to 26 ounces. Stands the drouth better than any other variety.

By the Potomac Fruit-Growers' Society it was pronounced of superior excellence in size, form, color, solidity, evenness of ripening, and flavor.

L. J. Tuttle, Assistant Treasurer, United States, says: I find the "Arlington" has in a remarkable degree all the requisites of a perfect Tomato. I know nothing that equals it.

The President's Gardener says: The Arlington Tomato, tested under my supervision in the President's gardens, was superior to any other kind.

D. W. Harrington, Washington, D. C., says: I tested it on my farm the past season side by side with the "Trophy," "General Grant," and "Feejee," and while my other plants were older and larger when set, the "Arlington" ripened fully ten days before any of the others, and has the further peculiarity that the same vines bear an abundance of fruit until the frost kills them, while all other kinds with me have required an extra set of plants for late fruit. Its solidity and flavor alone are enough to mark its superiority over anything I have ever seen.

Many letters, from persons who have tested it the past season, speak in the strongest terms of its superiority over all others.

Seed saved from selected fruit, 25 cts. per packet; 5 packets for \$1. Address

B. K. BLISS & SONS,
 P. O. Box No. 5,712, New York.

NOW READY.
CROSMAN BRO'S
 Illustrated and Descriptive Catalogue AND Guide to the Flower & Vegetable Garden FOR 1874.
 Beautifully illustrated, and containing a magnificent Colored Plate of Seven New and Popular Flowers, will be sent Free upon receipt of stamp.
 Don't fail to secure a copy of our Catalogue before purchasing your seeds. Address
CROSMAN BRO'S,
 (Established 1840.) Rochester, N. Y.

CHASE BROTHERS & WOODWARD,

CATALOGUE OF FLOWER AND VEGETABLE SEEDS—Full directions—reliable lists.



Seeds furnished fresh, pure, true to name, and of the best quality.

SEEDSMEN
 ROCHESTER, N. Y.
CATALOGUES SENT FREE.

New and Rare Plants FOR SPRING OF 1874.

John Saul's Catalogue of New and Beautiful Plants will be ready in February, with a colored plate. Mailed free to all my customers; to others, price 10 cents. A plain copy to all applicants free.

JOHN SAUL, Washington City, D. C.

FRESH AND RELIABLE EASTERN GROWN VEGETABLE SEEDS.

My crops of choice Onion, Cabbage, Beet, Cucumber, Lettuce, Corn, Beans, Peas, Squash, Tomato, Turnip, and all other Vegetable Seeds are in store in prime order, and I would be glad to send my *Retail Priced Catalogue* to all Gardeners or Farmers, confident that the quality of my Seeds will give great satisfaction.

I make a specialty of growing choice large Red and Yellow Danvers Onion Seed. For terms, etc., see my 1874 Seed Catalogue. Special rates to Granges and Clubs.

Address **R. D. HAWLEY,**
 Seed and Implement Warehouse, HARTFORD, CONN.

CHOICE SEEDS.



FOR 1874

Sent free to our customers, and to all others on receipt of two 2-cent stamps for the postage.

HOVEY & CO.,
 53 North Market St., Boston, Mass.

SEEDS! PLANTS! TREES! Our Catalogues of Garden, Field, and Flower Seeds, Roots, Bulbs, Greenhouse and Bedding Plants, Vegetable Plants, Seed Potatoes, Fruit, Shade, and Ornamental Trees, Vines, Shrubs, Roses, Small Fruits, etc., to all on application. PREMIUMS on Vegetables grown from our Seed. Send for List. **D. H. BROWN & SONS, SEEDSMEN,** 20 HIRAM STREET, New Brunswick, N. J.

GARDENERS declare my Garden Manual valuable as a \$3 work. Small but full of labor-saving methods and valuable ideas learned in many years' extensive market gardening. Sent for two stamps.
J. B. ROOT, Seed Grower, ROCKFORD, ILL.



My business is to supply, what every farmer of experience is most anxious to get, perfectly reliable Vegetable and Flower Seed. With this object in view, besides importing many varieties from reliable growers in France, England, and Germany, I grow a hundred and fifty kinds of vegetable seed on my four seed farms, right under my own eye. Around all of these I throw the protection of the three warrants of my Catalogue. Of new vegetables I make a specialty, having been the first to introduce the Hubbard and Marblehead Squashes, the Marblehead Cabbages, and a score of others. My Catalogue, containing numerous fine engravings, taken from photographs, sent free to all.

JAMES J. H. GREGORY, Marblehead, Mass.

AMATEUR CULTIVATORS GUIDE
 TO THE FLOWER AND KITCHEN GARDEN
 ENLARGED AND IMPROVED.
 Magnificent Colored Plate
 Hundreds of Engravings, beside Descriptive Price List of 3000 varieties of choice Flower and Vegetable Seeds, Rare Gladioli, Lilies, &c., &c. Full directions for culture. Complete in every respect. Sent free on receipt of two stamps. Address
WASHBURN & CO., BOSTON, MASS.

SEEDS!
 FLOWER AND VEGETABLE.
 Elegant Books on Gardening GIVEN AWAY
 as premiums to our customers. See our elegant new illustrated Catalogue, 100 pages, now ready Free to all. **WOOD & BULL,** Geneva, N. Y.

SEEDS! SEEDS! SEEDS! Spooner's Prize Flower Seeds; 12 varieties Splendid Aster Seeds mailed to applicants upon receipt of \$1.00. New Illustrated Seed Catalogue free. Address **WM. H. SPOONER,** 4 Beacon St., Boston.



Fottler's Early Drumhead.

Farmers and Gardeners, you all need this Cabbage for two reasons: 1st, because it is the earliest of all the Drumhead varieties; 2d, because every plant on an acre will make a large and solid head. Seed of my own growing sent post-paid by me for 15 cts. per package, 75 cts. per ounce, \$3 per pound. My Seed Catalogue free to all applicants.

JAMES J. H. GREGORY, Marblehead, Mass.

Seed Oats. Seed Oats.

YELLOW LATHANNIAN.—With three years' trial they prove superior to all others. The favorable testimonials received from many States from those who have tested them show that they are adapted to every variety of soil. Four pounds by mail, post-paid, \$1; bush, by ex., \$2; one bbl. of four bush, \$5.

SEED POTATOES.—Early Rose and Late Rose, \$3 per bbl.; Peerless, \$2.25; Early Vermont, one pound by mail, 75c.; bush, by ex., \$6. Compton's Surprise, 75c. per lb. Send for Catalogue containing list of choicest Farm and Garden Seeds. Address

S. B. FANNING, Jamesport, Suffolk Co., N. Y.



Our Annual Spring Catalogue of Flower and Vegetable Seeds is now ready. Free to all on application.

New Catalogue
 of choice Fruit and Ornamental Trees, Flowering Shrubs, and Hardy Plants sent free. Contains many things new and rare.
EDWIN ALLEN,
 New Brunswick Nurseries, N. J.

THE DUDLEY SEED FARM.
 Send by Postal-Card for my new Spring Catalogue of Seeds, Plants, Lilies, Gladioli, etc., etc. Special inducements offered.
G. A. LAW,
 Rosendale, near Boston, Mass.

VEGETABLE PLANTS AND ROOTS.

For Farmers and Market Gardeners.

Early Jersey Wakefield Cabbage Plants (cold frame), \$10 per 1,000. Early York, Flat Dutch, and Winningstadt, same rates. Early Sprout Cauliflower Plants (cold-frame), \$20 per 1,000. Rose-radish sets, \$6 per 1,000. Asparagus, Van Sicken's Colonial, 2 year old, \$8 per 1,000.

All the above are now ready for shipment. New Sandringham Dwarf Celery contracted for in quantities, at special rates, delivered in July. Purchasers to the amount of \$25 worth of Vegetable Plants will be sent our work on Market Gardening, "Gardening for Profit," gratis; the price of the book is \$1.50. To such as do not want it, the value will be sent in additional plants.

Peter Henderson & Co. SEEDSMEN, 35 CORTLANDT ST., New York.

BEAUTIFUL EVER-BLOOMING

ROSES, STRONG POT-PLANTS, Suitable for Immediate Flowering. Sent Safely by Mail, Post-paid.

5 Splendid Varieties, purchaser's choice, \$1; 12 for \$2. For 10 cents additional we send

MAGNIFICENT PREMIUM ROSE.

Our elegant SPRING CATALOGUE for 1874, describing more than 200 FINEST VARIETIES of ROSES, and containing full directions for culture, with chapters on winter Protection, Injurious insects, etc., now ready. SENT FREE.

THE DINGEE & CONARD CO., Rose Growers, WEST GROVE, Chester County, Pa.

ROSES 6 for \$1, 14 for \$2, by mail, post-paid. A large collection of Bedding Plants, Hardy Shrubbery, etc. Plants by mail a specialty. A SPLENDID PREMIUM FUCHSIA with each PACKAGE where 10c. is added. Catalogue free on application. Address JOSEPH T. PHILLIPS, West Grove, Chester Co., Pa.

PLANTS BY MAIL PACKING AND POSTAGE FREE. LADIES READ THIS. 12 Verbenas, 12 kinds, \$1.00. 10 Bedding Plants, 10 kinds, 1.00. 10 Basket Plants, 10 kinds, 1.00. 6 Roses, 6 kinds, 1.00. 6 Geraniums, 6 kinds, 1.00. All named sorts, our choice. 100 other things cheap. A Premium offered to Climbs. A 56 page Catalogue Free. 20th year, 300 acres, 11 Greenhouses. Address: STORRS, HARRISON & CO., Painesville, Lake Co., Ohio.

THORBURN'S FLOWER SEEDS. Our annual descriptive Catalogue of Flower Seeds, containing all the novelties, also Hybrid Gladiolus and Spring Bulbs, is now ready for mailing free to applicants; also, Tree Seed Catalogue. J. M. THORBURN & CO., 15 John St., New York.

VERBENAS.—1 Doz. Fine Varieties packed and sent anywhere for \$1.00. BEDDING PLANTS.—1 doz. ass'd for Bloom through the Summer, \$1.50, with Basket. ROSES.—1 Doz. assorted Tea, China, and Hybrid for \$2.50, packed and shipped. Send for Catalogue. B. P. CHICHELL, Cincinnati, O.

VERBENA SEED. Extra superb, mixed, from finest flowers only. Per package, 25 cts., 5 packages, \$1. Plant Catalogue on application, inclosing 3-ct. stamp. Address DEXTER SNOW, Chicopee, Mass.

FLOWER SEEDS I will send by mail, post-paid, 50 varieties of choice Flower Seeds for \$2.00. 25 varieties for \$1.00. 10 varieties for 50c. R. H. HARRIS, Yarmouth Port, Mass.

FREE. The Descriptive Price-List of Trees, Shrubs, Grape-Vines, Small Fruits, Roses, and Bedding Plants, which we forward by mail or express. A large assortment of nursery stock suited to Lawns, Parks, and Cemetery planting. Send for Price-list. WILLIAM H. MOON, Morrisville, Pa.

SWEET POTATOES FOR SEED.—Nansmond, Southern Queen, and Early Red. \$2 for \$ bushel; \$6.50 bbl. (3 bush.); \$30 for 5 bbls. Plants in May and June, \$2.50 per 1,000; \$30 per 1,000. W. W. RATHBONE, Marietta, Ohio.

Matthews' Garden Seed Drill. Devised by the inventor and manufacturer of the Holbrook "Regulator" Drill to excel that or any other ever used. Send for descriptive circular to J. B. SMALL, 10 S. Market St. Boston, Mass.

TREES, Etc.

SPRING OF 1874.

We invite the attention of Planters and Dealers to our large and complete stock of

Standard and Dwarf Fruit Trees, Grape Vines, Small Fruits, Ornamental Trees, Shrubs, Roses, New & Rare Fruit & Ornamental Trees, Evergreens, and Bulbous Roots, New & Rare Green & Hot House Plants.

Prompt attention given to all inquiries. Descriptive and Illustrated Priced Catalogues sent prepaid on receipt of stamps, as follows:

No. 1—Fruits, 10c. No. 2—Ornamental Trees, 10c. No. 3—Greenhouse, 10c. No. 4—Wholesale Free. Address Established 1840.

ELLWANGER & BARRY, Mount Hope Nurseries, ROCHESTER, N. Y.

Sweet 600,000 SWEET CHESTNUT. 10,000 SPANISH CHESTNUT. A Circular free. 200,000 GREEN-HOUSE PLANTS. A 56-page Catalogue free. 25,000 ROSES, dormant. 25,000 ROSES, in pots, for Spring. 100,000 GRAPE-VINES. 5,000 TULIP TREES, 6 to 10 feet. 50,000 PEACH TREES, First-class. 2,000 WEEPING MOUNTAIN ASH. 1,000,000 EVERGREENS. Best in the market. 100,000 DECIDUOUS TREES. 500,000 FRUIT TREES. 20th Year. 300 Acres. 11 GREEN-HOUSES. Address STORRS, HARRISON & CO., PAINESVILLE, Lake Co., Ohio.

Trees! Flowers!

All Kinds—Wholesale and Retail. Dutches Nurseries, Poughkeepsie, N. Y. Choice Stock. (Established 1863.) Cheap Rates. ELMS for avenues, fine Norway Spruce, American Arborvita, Hemlock, etc. Walter Grape (only American raisin Grape) and Downing Gooseberries, Specialties. Greenhouse and Bedding Plants very cheap, in large or small quantities. Send for Priced Catalogue. OFFER! 12 Choice Bedding Plants in 8 sorts, sent by mail, post-paid, for \$1. Safe arrival guaranteed. An extra Plant to all who state where they saw this adv't. W. L. FERRIS, JR., & CO., late L. M. Ferris & Son.

THE TEBO NURSERIES CO.

IN perfection of organization for growing and handling stock, in the quantities and qualities of stock ready for market, these Nurseries are now unrivaled west of the Mississippi. We offer in special quantities for Spring of 1874, Apples, Hedges and other Grabs, Wild Goose Plums, Utah Cherries, Peaches, Osage Orange, etc. Dealers and Nurserymen are invited to correspond with us before contracting elsewhere. THE TEBO NURSERIES CO., Clinton, Mo.

HEIKES NURSERIES.

OUR locality and conveniences for handling stock enable us to ship earlier and with greater promptness than any other establishment in the Northern States. Our assortments are full, comprising the following in large quantities: Apples, Standard and Dwarf Pears, Peaches, Grapes, Currants, Mt. Seedling and Houghton Gooseberries, Raspberries, Blackberries, Plum Seedlings, Peach Seedlings, for transplanting, Osage Orange, Goldeu Dwarf Peaches, Blood-Leaved Peaches, etc. THE HEIKES NURSERIES CO., Dayton, O.

PURE CANE SEED.

VARIETIES.—LIBERIAN, REGULAR SORGO, and OOMSEANA. PRICES.—By mail, postage paid, 50 cts. \$ D.; by express, 25 lbs. or less, 30 cts. \$ D.; over 25 lbs. 20 cts. \$ D., package included. The Neazana is dropped from our list. Regular Sorgo and Oomseana are becoming subject to mildew and rust. We therefore recommend the Liberian for general cultivation. Two to three pounds required per acre. Money with order. Sorgo Hand-Book sent free. BLYMYER MANUFACTURING CO., Successors to Blymyer, Norton & Co., Cincinnati, O.

FLOUR CORN produces well, makes fine flour like wheat. Put up in large packages for seed, and sent by mail for 25 cts. by HORTON & CRANE, Bloomingburgh, N. Y.

HARRINGTON'S PATENT.

The only com-Seed Sower and CULTIVATOR Made only by AMES PLOW CO., 53 Beekman St. New York. Send for Circular.

ALLEY'S PLANET 4 STYLES. One just out. The Farmers and Cultivators, for Farm or Garden. Light and durable. No equal, Domestic or Imported. Descriptive Circulars of S. L. ALLEN & CO., 119 S. 4th St., Phila., Pa.

STRAWBERRIES. 23 varieties. Pure. 100 or less by mail. doz. 100, 1,000, 10,000. Monarch of West, best, \$1.00 \$6.00 \$50.00. Kentucky, good, late, 40 1.00 4.00 \$30.00. Wilson Albany, old tried, good, 30 80 3.00 25.00. Chas. Downing, valuable, 30 80 3.00 20.00. Cumming's Seedling, Kissina, Early Surprise, Hudson's Early, Champion—new sorts, \$1 doz., \$5 per 100; doz. of each and doz. Monarch of West for \$4. Raspberries; 8 varieties. Doz. by mail, post paid. Brandywine, hardy, good, \$1.00 doz.; \$4.00 100; \$30 1,000. Herstine, hardy, very large, 1.50 " 10.00 " 75 ". Kittatiny Blackberry, 50 " 1.50 " 10 ". Other Blackberries, Currants, Asparagus Roots, etc. Extra Early Vermont Potatoes, 40c. lb.; \$1.50 4 lbs.; \$2 peck; \$8 bushel. Compton's Surprise Potatoes, 75c. lb.; \$2 4 lbs.; \$4 peck; \$12 bushel. Early Beatrice and other Peach trees. Catalogue free. JOHN S. COLLINS, Moorestown, N. J.

New Blackberry! HOOSAC THORNLESS.

No Thorns to Scratch; 8 years under cultivation; Hardy. Never has winter-killed; quality the best; in productiveness unequalled. Prepaid by mail, \$1.00 each; 2 plants, \$1.50; 6 plants, \$3.00; 12 plants, \$5.00. For full history of berry and plant, with testimonials, address at once FRANK FORD, Ravenna, O. Agents wanted everywhere; liberal inducements.

FREE. My elegant Illustrated Catalogue of Ferns, 75 cts. per dozen. Address W. B. WOODRUFF, Florist, Westfield, N. J.

RASPBERRIES, Currants, etc., at low rates. Monarch of the West Strawberry Plants, genuine, \$1 per doz., \$6 per 100, post-paid. Boyden No. 30 at \$1.25 per 100. Wilson's, \$3.50 per 1000. Berry Baskets—in lots of 50 or 50,000. Fruit Trees and Vines. Price-list free. R. H. HAINES, Malden-on-the-Hudson, N. Y.

100,000 Strawberry Plants

Large stock of the celebrated Seth Boyden (No. 30) variety. Terms very reasonable. Send for circular. Address E. P. ROE (Author of "Play and Profit in my Garden"), Highland Falls, N. Y.

Wilson's Early Blackberry and other Small Fruit Plants. Also Peach Trees and a general Nursery Stock at low rates. For prices address DAVID BAIRD, Manalapan, N. J.

STRAWBERRY, RASPBERRY, BLACKBERRY, Asparagus Roots, and Seed Potatoes for sale by SAMUEL C. DE COU, Moorestown, Burlington Co., N. J.

DEAR Souvenir du Congres (figured in Agriculturist, Dec. No.). Nearly twice the size the Bartlett—ripening before it. Send for Catalogue describing 16 new varieties apples and pears. Clons at low rates. W. S. CARPENTER & SON, Rye, Westchester Co., N. Y.

The Rochester BERRY-BASKET. Light, durable, well ventilated, low priced. Agents wanted. Gen'l Ag'ts, JOHN S. COLLINS & CO., Moorestown, N. J.

GRAPE-VINES.

All leading varieties. Extra quality. Genuine. Cheap. Price-list free. T. S. HUBBARD, Fredonia, N. Y.

1,000,000 Grape-Vines

The best and cheapest in America, for sale. No one dare undersell me. Concord, 1 year, \$25 per 1,000; Select, \$35, 2 year old \$40; Extra, \$45. Delaware, Eumelan, Martha, Hartford, Diana, Rogers, and all other sorts—very cheap. Also all sorts of Small Fruits and Trees—cheapest. Address Dr. H. SCHRODER, Bloomington, Ill.

200,000 Transplanted Evergreens \$10.50 will buy 1,000 transplanted Arbor-vita, packed and delivered at R.R. or Express office. Catalogues, and How, When, and where to Plant Evergreens mailed for stamp. WM. MORTON & SON, Allen's Corner, Cumberland Co., Maine.

FARMS IN VIRGINIA,

With Dwellings, Barns, etc. Vegetation for New York markets four to six weeks earlier than New Jersey lands. Quick and Cheap Steam Transportation to All the Northern Markets. Prices \$5 to \$25 per acre. Farms both large and small. Lists with full particulars by addressing WM. P. MOORE & CO., Suffolk, Va.

TOBACCO Growers, Truck Raisers, and Farmers generally—send for our Circular and Price-list of the best Implement made for riding Tobacco, Cabbage, and other land. Also for covering potatoes, etc., and hoeing first time it has no equal. GEORGE S. TAYLOR, Agent, Chicopee Falls, Mass.

FOR SALE.—Five Stock, Grain, and Dairy Farms \$5 miles S. W. of St. Louis; over 800 acres cultivated; 1,260 acres on turnpike; unsurpassed for beauty, quality, health, water, timber, buildings, and schools. Terms low and easy if applied for soon to SAM, BYRNS, Hillsboro, Jeff. Co., Mo.

Twenty-Ninth Annual Report
OF THE
New York Life Insurance Co.

OFFICE:
346 and 348 Broadway.
JANUARY 1, 1874.

Amount of net cash assets, Jan. 1, 1873. \$21,571,842 76
INCOME.
Premiums and annuities \$6,131,521 83
Interest received and accrued 1,418,094 83—7,549,616 21
\$29,121,458 97

DISBURSEMENTS.
Losses by death \$1,446,123 01
Dividends and returned premiums on canceled policies 2,344,203 33
Life annuities, matured endowments, and reinsurance 82,629 13
Commissions, brokerages, and agency expenses 445,832 91
Advertising and physicians' fees 115,593 67
Taxes, office, and law expenses, salaries, printing, revenue stamps, etc. 259,045 57
4,693,579 65
\$24,427,879 32

ASSETS.
Cash in Trust Company, in bank, and on hand \$1,661,537 85
Invested in United States, New York State, and other stocks (Market value, \$1,937,330 24) 4,850,195 30
Real estate 1,768,174 14
Bonds and mortgages (secured by real estate valued at \$44,000,000; buildings thereon insured for over \$13,700,000, and the policies assigned to the Company as additional collateral security) 14,135,265 23
Loans on existing policies (the reserve held by the Company on these policies amounts to \$4,052,419 96) 962,112 98
Quarterly and semi-annual premiums due subsequent to Jan. 1, 1874 563,365 83
Premiums on existing policies in course of transmission and collection (estimated reserve on these policies, \$300,000, included in liabilities) 387,936 34
Amounts due from agents 26,459 77
Interest accrued to Jan. 1, 1874 175,831 96
24,430,579 32

ADD.
Excess of market value of securities over cost. \$87,125 01
Cash assets, Jan. 1, 1874. \$24,518,004 36

APPROPRIATED AS FOLLOWS:
Adjusted losses due subsequent to Jan. 1, 1874 271,655 00
Reported losses, awaiting proof, etc. 207,715 00
Reserved for reinsurance on existing policies insuring \$125,594,275 20, participating insurance at 4 per cent, Cash's net premium; and \$108,113 65 non-participating (at 5 per cent, Cash's net premium) 22,057,449 38
Dividends outstanding 208,630 87—22,775,449 95
Divisible surplus. \$1,742,554 41

From the undivided surplus of \$1,742,554 41 the Board of Trustees has declared a reversionary dividend, available on settlement of next annual premium to participating policies, proportioned to their contribution to surplus.
The cash value of such reversion may be used in settlement of premium, if the policy-holder so elect.

During the year 8,834 policies have been issued, insuring \$26,621,000.

TRUSTEES:

- | | |
|--------------------|---------------------------|
| MORRIS FRANKLIN, | GEORGE A. OSGOOD, |
| DAVID DOWS, | HENRY BOWERS, |
| ISAAC C. KENDALL, | CHARLES L. ANTHONY, |
| DANIEL S. MILLER, | SANFORD COBB, |
| HENRY K. BOGERT, | EDWARD MARTIN, |
| JOHN MAIRS, | EDWIN HOYT, |
| WM. H. APPLETON, | H. B. CLAFFIN, |
| ROBERT B. COLLINS, | WILLIAM H. BEERS, |
| WILLIAM BARTON, | J. F. SEYMOUR, |
| WM. A. BOOTH, | CORNELIUS R. BOGERT, M.D. |

MORRIS FRANKLIN,
President.

WILLIAM H. BEERS,
Vice-Pres. and Actuary.

- THEODORE M. BANTA, Cashier.
D. O'DELL, Superintendent of Agencies.
CORNELIUS R. BOGERT, M.D., and GEORGE WILKES, M.D., Medical Examiners,
CHARLES WRIGHT, M.D., Assistant Medical Examiner.

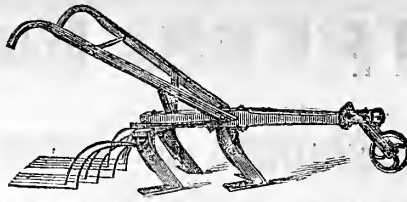

VICTOR HORSE HOE.
BEST AND CHEAPEST STEEL HOE in use.
THOROUGHLY Pulverizes and works close to plants, RAKE Attach't works the weeds out, has Hilling Plows First Premium SILVER MEDAL New England Fair, 1872.
EAGLE SEED SOWER. Plants in Hills or Drill 4 Sizes Prices \$6 to \$16.
CLIPPER WHEEL HOE. \$4 & \$5.50. Agents Wanted (Circulars Free.)
E. D. & O. B. REYNOLDS,
NORTH BRIDGEWATER, MASS.

Or **CARR & HOBSON,** Sole Agents,
56 Beekman St., New York.

The American Pulverizing Cultivator

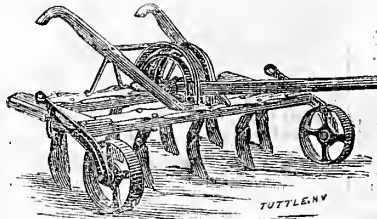

The greatest results with the least draft.
No more "second plowing."
Send for descriptive circular to the sole manufacturers,
JULIAN GIFFORD & BRO., Hudson, N. Y.
Or **J. M. CHILDS & CO.,** Utica, N. Y.



The Sugar Maker's Friend
More Agents wanted to canvass and sell Post's PATENT GALVANIZED METALIC BUREKA SAP SPOON and BUCKET HANGERS. Circulars and Terms sent on receipt of 20 cts. to pay postage.
Address C. C. POST, Manuf. and Patentee, Burlington, Vt.

The Pulsometer or Magic Pump.

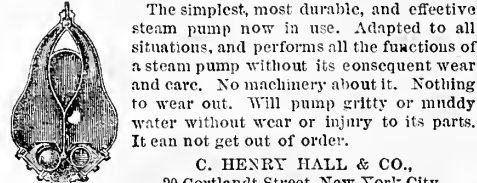

The simplest, most durable, and effective steam pump now in use. Adapted to all situations, and performs all the functions of a steam pump without its consequent wear and care. No machinery about it. Nothing to wear out. Will pump gritty or muddy water without wear or injury to its parts. It can not get out of order.
C. HENRY HALL & CO.,
20 Cortlandt Street, New York City.

\$75 PER WEEK
made by our agents throughout the country selling our celebrated La Perle Rubber Goods. Indispensable articles for Ladies and Children's wear.
LA PERLE RUBBER CO.,
90 Chambers Street, New York.

W. A. COVERT & CO., Produce & Commission Merchants, No. 65 Pearl Street, New York. "Quick sales and prompt returns." Send for our weekly Prices-current and Marking Plate.

ADVERTISING RATES.

American Agriculturist.
ENGLISH EDITION.
Inside Pages, \$1.50 per line (agate), each insertion.
Open Pages (open without cutting), \$2 per line.
Last Page, and 2d and 3d Cover Pages—\$3.50 per line.
Pagenext to Reading and Last Cover Page—\$3.00 per line
No advertisement inserted for less than \$5.00.
GERMAN EDITION.
Inside Pages, 25 cents per line, each insertion.
Business Notices and Last Page, 40 cents per line.
No advertisement inserted for less than \$1.00.

Hearth and Home.

Inside Pages, per line (agate), each insertion.....50 cents.
Business Notices, 7th Page, and Last Page.....75 cents.
Reading Notices per line.....\$1 00
No advertisement inserted for less than \$2.00.
No Advertisement of Medicines or Humbugs received.
Address all orders to the
ORANGE JUDD COMPANY,
245 BROADWAY, NEW YORK.

THE HERALD OF HEALTH FOR 1874.

THREE EXTRA NUMBERS FREE TO NEW SUBSCRIBERS.

The January number contains a remarkable article by GEORGE DARWIN, son of the great naturalist, entitled

Sanitary Restrictions to Marriage.

Every unmarried person, male or female, should read it.

The February number contains:

Enlightened Motherhood.

By MRS. CORBIN.

SEX IN EDUCATION.

By MRS. HORACE MANN.

The March Number, among other things, contains:

HEALING THE SICK BY PRAYER.

By REV. JOHN KELLY, of London.

THE WASTES OF LIFE.

By REV. W. S. CLARK.

Prevention and Treatment of Consumption.

(This is the first of a series of six valuable papers.)

Receipt for Graham Bread.

To Prevent Constipation.

CAUSE OF DEBILITY.

Catarrh—Its Treatment.

SCROFULOUS CHILDREN.

To Get Free From Aches and Pains.

Each number contains valuable papers on the home treatment of diseases, as Sick Headache, Dyspepsia, Teaching Children Concerning Sexual Matters, the Physical Education of Delicate Children, Diseases of Women, and everything that pertains to better health, physical and mental, for men, women, and children. It should be in every family where there is an invalid or any sickness. It will teach how to avoid all, and rear families

in Health, Strength, and Beauty.

\$2.00 a Year. Samples 15 Cents.

Every Subscriber for 1874 gets free

The Complete Works of Shakspeare.
The Complete Works of Shakspeare.
The Complete Works of Shakspeare.

In one volume of over 1,000 pages and 36 illustrations, the most marvelous instance of cheapness ever known, or our Chromo, the ARTIST COW (see description in December *Agriculturist*). Both premium and Herald one year, \$2.50. Address WOOD & HOLBROOK, 15 Lighthouse St., New York.

Parturition Without Pain;

Or, A Code of Directions for Avoiding most of the Pains and Dangers of Child-Bearing.

Edited by M. L. HOLBROOK, Editor of the Herald of Health.
CONTENTS.—1. Healthfulness of Child-Bearing. 2. Dangers of Preventions. 3. Medical Opinions as to Escaping Pain. 4. Preparation for Maternity. 5. Exercise during Pregnancy. 6. The Sitz Bath and Bathing generally. 7. What Food to Eat and what to Avoid. 8. The Mind during Pregnancy. 9. The Ailments of Pregnancy and their Remedies. 10. Female Physicians, Anesthetics.

To which are added: 1. The Husband's Duty to his Wife. 2. Best Age for Rearing Children. 3. Shall Sickly People become Parents? 4. Small Families. 5. Importance of Physiological Adaptation of Husband and Wife. 6. Celibacy. 7. Effects of Tobacco on Offspring. 8. Latest Discoveries as to the Determining the Sex of Offspring. 9. Father's vs. Mother's Influence on the Child. 10. Shall Pregnant Women Work? 11. Effects of Intellectual Activity on Number of Offspring. 12. Size of Pelvis, and its Relation to Healthful Parturition, etc., etc.

Godley's Lady's Book says: "We give our cordial approbation to this work, and would like to see it in the hands of every mother in the land."
The course recommended can not fail to be beneficial.—*Beecher's Christian Union.*

Glad to see such books from the American press.—*Methodist (New York).*
"A work whose excellence surpasses our power to commend.—*New York Mail.*

The price by mail, \$1.00, puts it within the reach of all. Sent with the Herald of Health, both Premiums and Sexual Physiology, advertised in another column, for \$5.00.
Address WOOD & HOLBROOK, Publishers,
13 and 15 Lighthouse St., New York.

\$1,500 IN PREMIUMS. Important to Potato Growers.

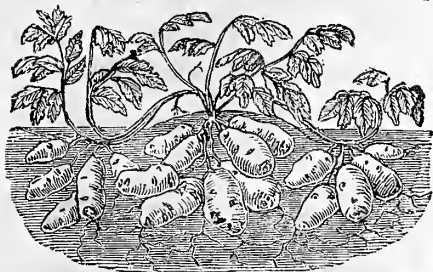

COMPTON'S SURPRISE—Showing Habit of Growth.

\$750.00 to be divided among the six successful competitors who shall produce the largest quantity of either of the following varieties of Potatoes: **EXTRA EARLY VERMONT, BROWNELL'S BEAUTY, or COMPTON'S SURPRISE**, from one-quarter of an acre of measured ground. \$250 for each variety.

\$750.00 to be divided among the six successful competitors who shall produce the largest quantity from **ONE POUND** of the seed of either of the above named varieties. \$250 for each variety. Subject to conditions named in our Potato Catalogue, a copy of which will be mailed to all applicants.

The Seed in all cases to be purchased from us. **BLISS'S GARDENERS' ALMANAC** and Abridged Catalogue. 100 pages, illustrated. Mailed to all applicants inclosing two three-cent stamps. **Bliss's Illustrated Catalogue and Guide to the Flower and Kitchen Garden**, 200 pages, several hundred illustrations, with a beautifully colored lithograph. Mailed to all applicants upon receipt of 25 cts. Address

B. K. BLISS & SONS,
23 Park Place and 20 Murray St.,
P. O. Box 5712, New York.

Geneva Nursery. Established 1846.

400 Acres of Fruit and Ornamental Trees.
LARGE STOCK OF
Pear Trees—extra size, Dwarf and Standard.
Pear Trees—first class, 3 and 4 year old.
Pear Trees—first class, 1 and 2 year old.
Apple Trees—extra size, 3 to 5 feet.
Apple Trees—first class, 3 and 4 year old, 5 to 7 feet.
Peach, Plum, Quince, Cherry, Grape.
Dwarf Apple, Gooseberry, Currants.
The celebrated new Herstine Raspberry.
100,000 Apples, grafted in the root for Nursery planting—cheap. All at lowest prices. Catalogues free.
W. & T. SMITH, Geneva, N. Y.

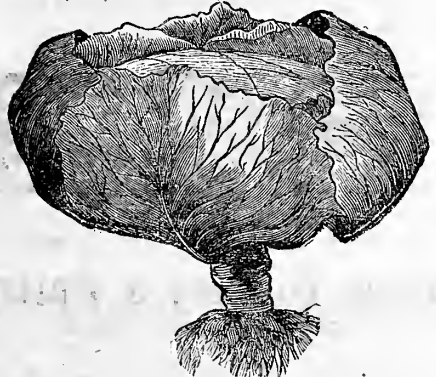

Marblehead Mammoth!

You will find in my Seed Catalogue letters from a score of people who, by following the directions sent with every package of seed, have raised this Cabbage to weight from **30 to 60 lbs. a single head!** I was the original introducer of this giant Cabbage, and my seed is all grown from heads that are extra large and very solid. Sent post-paid by me, 25 cts. per package; \$1 per ounce; \$10 per lb. My Seed Catalogue sent free to all applicants.
JAMES J. H. GREGORY, Marblehead, Mass.



BUILDING FELT.
This water-proof material, resembling fine leather, is for outside work (no tar substances used) and inside, instead of plaster. Felt carpetings, etc. Send two 3-cent stamps for circular and samples.
C. J. FAY, Camden, N. J.

\$10 to \$20 a Day.—Agents wanted for Everybody's Monthly. Only 50c. a year with elegant chromo. Particulars free. Address Everybody's Monthly, Cleveland, O.

A CURIOSITY for old and young. Chain 14 inches long of running rings. Sample sent by mail for 25 cts., postage paid. Circular sent free.
WILCOX CRITTENDEN & CO., Middletown, Conn.

B 4 U ORDER SEEDS, BRIGGS & BRO'S January Quarterly.

The finest **Floral Work** ever issued in this country. Published Quarterly—the four numbers sent to any address for 25 cents—comprising an Illustrated and Descriptive Catalogue of the Seeds, Bulbs, and Plants sold by **BRIGGS & BROTHER, Seedsmen and Florists**, Rochester, New York, together with elaborate treatises upon the care and cultivation of the same. **Over 1,000 Premiums** taken in the United States in 1873 upon the products of **BRIGGS & BROTHER'S SEEDS.**

The January number alone will be worth more than a \$2 book. Customers for \$1.00 or upward become subscribers. We challenge comparison on prices, reliability of Seeds, and size of packets. Address
BRIGGS & BROTHER,
Rochester, N. Y.

- CTSR.** Tested Novelties & very Desirable Vegetable and Flower Seeds.
- CTSR.** Westchester Co. (N. Y.) Cucumber Pickle Seed produces at the rate of 400,000 to the acre. Arlington, Canada Victor, Trophy, and Hathaway's Excelsior Tomatoes. Gipsy Water-melon (best ever introduced). Nectar and Hackensack Musk-melons, Mammoth Chili Squash (often weighs 200 lbs.), Marblehead Squash. Fottler's Early Drumhead Cabbage, Egyptian Beet. Each 10 cts. pkt., 6 pkts. 50 cts., 13 pkts. \$1.00.
- CTSR.** Double Camellia Balsam, Double Portulaca Mixed Colors, Diadem Pink. Each 10 cts. pkt.
- CTSR.** My Catalogue for 1874 (48 pages) and a pkt. of any of the above seed sent to any address for 10 cts., or without seed for a 3-cent stamp.
- CTSR.** It is no longer an experiment to plant my seeds, as any one can learn by "what my customers say" in my Catalogue. **H. E. ACKER,** Seed Grower, Woodbridge, N. J.

New and Rare Plants for 1874.

- Diplopappus Chrysofillus.**—A new dwarf hardy Evergreen, lower side of foliage covered with yellow dust. 50 cts.
 - Double White Geranium, Aline Sisley.**—The best double white, strong. \$1; \$9 per doz.
 - Double White Geranium, Album Plenum.**—75c.
 - Zonale Geranium, "Cyclope."**—The finest deep purple. 50 cts.
 - Golden Bi-color, "Gen'l MacMahon."**—The finest yet introduced; excellent bedder. 50 cts.
 - Double Petunia, "Sovereign."**—Purple and white blotched; fine form; good bedder. 25 cts.
 - Primula Japonica.**—The "Queen of the Primroses." The flowers are produced on stems from eighteen inches to two feet high, with five to six separate whorls of flowers of a deep rosy purple, with a white eye. Strong flowering plants, in 3-in pots, 50 cts.; \$5 per dozen.
- The above will be mailed free at the prices affixed. For other novelties, send for Dreer's Garden Calendar for 1874, mailed free. Address
HENRY A. DREER,
No. 714 Chestnut St., Philadelphia, Pa.

Flower Seeds. Flower Seeds.

33 KINDS FOR \$1.00.
BY MAIL, POSTAGE PREPAID.
The subscriber, having over 40 years' experience in cultivating Flower Seeds, etc., has made a selection of all the most desirable flowers for general cultivation. The list comprises over 250 kinds, and a person selecting from it can obtain just as fine flowers as if selecting from an expensive fancy catalogue, at less than half the expense—as many on the list are sold by others at 10c., 15c., 20c., and 25c. per pkg. The list will be sent to all who apply for it.
G. R. GARRETSON, Flushing, L. I., N. Y.
Wholesale and retail dealer in all kinds of seeds.

THE IVY HILL NURSERY CATALOGUE

Of **SMALL FRUITS, SEEDS, and SEED POTATOES** will be mailed free to all applicants. Address
REISIC & HEXAMER,
Newcastle, Westchester Co., N. Y.



Improved Foot Lathes.

Small Engine Lathes, Small Gear Cutters, Hand Planers for Metal, Ball Turning Machines, Slide Rests, Foot Scroll Saws. The very best. Selling everywhere. Catalogues free.
N. H. BALDWIN, Laconia, N. H.
Just the articles for Artisans or Amateurs.

The Kansas Farmer.

In its 12th year. Enlarged, improved, and published weekly. All about Kansas. A large corps of able writers. Sample copy free to all applicants.
T. K. HUDSON, Ed. and Propr.
Topeka Kansas.



Our Illustrated Seed Catalogue for 1874 is ready for distribution, and will be sent to all who apply, inclosing a stamp for postage. This Catalogue contains a complete list of all the most valuable

SEEDS and GRAINS, including FLOWER SEEDS, NOVELTIES, etc., etc.

We offer a valuable premium as an inducement to Clubs and purchasers of large amounts.

R. H. ALLEN & CO.,
189 & 191 Water Street, New York.

WHAT--WHERE ---WHEN---HOW

To Plant Farm, Garden, and Flower Seeds; what they will cost, and all other desirable information in our

HAND-BOOK for 1874, Containing a Beautifully Colored Chromo.

Sent to all applicants, post-paid; on receipt of 10 cents, by **JAMES FLEMING, Seedsman,** 67 Nassau St., New York.

THE REASON WHY WE SELL

Two Millions

Of **ROSES, GREENHOUSE, and BEDDING PLANTS** annually is in consequence of our rates being less than half that at which they are usually sold. See Combined List of *Plants and Seeds, for Clubs, Dealers, or buyers in quantity.* Sent free on application.

Peter Henderson & Co.

SEEDSMEN AND FLORISTS,
35 CORTLANDT STREET, NEW YORK.

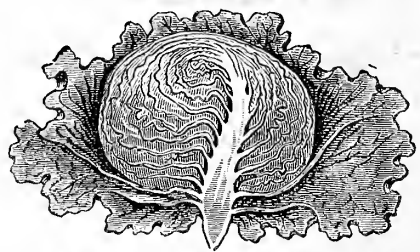

The HANSON LETTUCE.

The most tender, sweet, and delicious variety grown; free from any bitter or unpleasant taste; heads large and solid, often weighing 3 lbs. **Single pkg 25 cts. 5 pkgs \$1. A LIBERAL DISCOUNT TO DEALERS.** Send for Dreer's Garden Calendar for 1874, 168 pages, illustrated, with practical directions. Mailed FREE to all applicants.
HENRY A. DREER,
714 Chestnut St., Philadelphia, Pa.

A Household Necessity,

And just as represented, is the new *Triumph Sweet Corn*, which is the result of ten years' careful cultivation, and a peculiar selection of Seed. It is large, early, and very productive. That it surpasses all other varieties is clearly proven by the high testimonials received from prominent Market Gardeners, Seedsmen, and Agriculturists. I own and control all the seed stock of this variety, and it can be had only from the originator.

Free by mail at 25 cts. a package, or 5 pkts. \$1.00. Selected ears \$1.00 each. Address
DAVID C. VOORHEES, Blavenburg, N. J.

I will give a Premium of \$25.00 for the best six stalks having the largest and most perfectly ripened ears (kept pure from hybridization with any other corn) raised from the seed of *Triumph Sweet Corn* bought of me. Sent to me free before November 1st, 1874.

ADVERTISERS should send to **Geo. P. Rowell & Co.,** 41 Park Row, N. Y., for their *Eighty-page Pamphlet*, containing lists of 3,000 newspapers and estimates, showing the cost of advertising. Mailed free to all applicants.

AGENTS LOOK!—\$12 a day made selling A Scissors Sharpener and other wares. Sample 25 cts. Catalogue free. **T. J. HASTINGS & CO.,** Worcester, Mass.

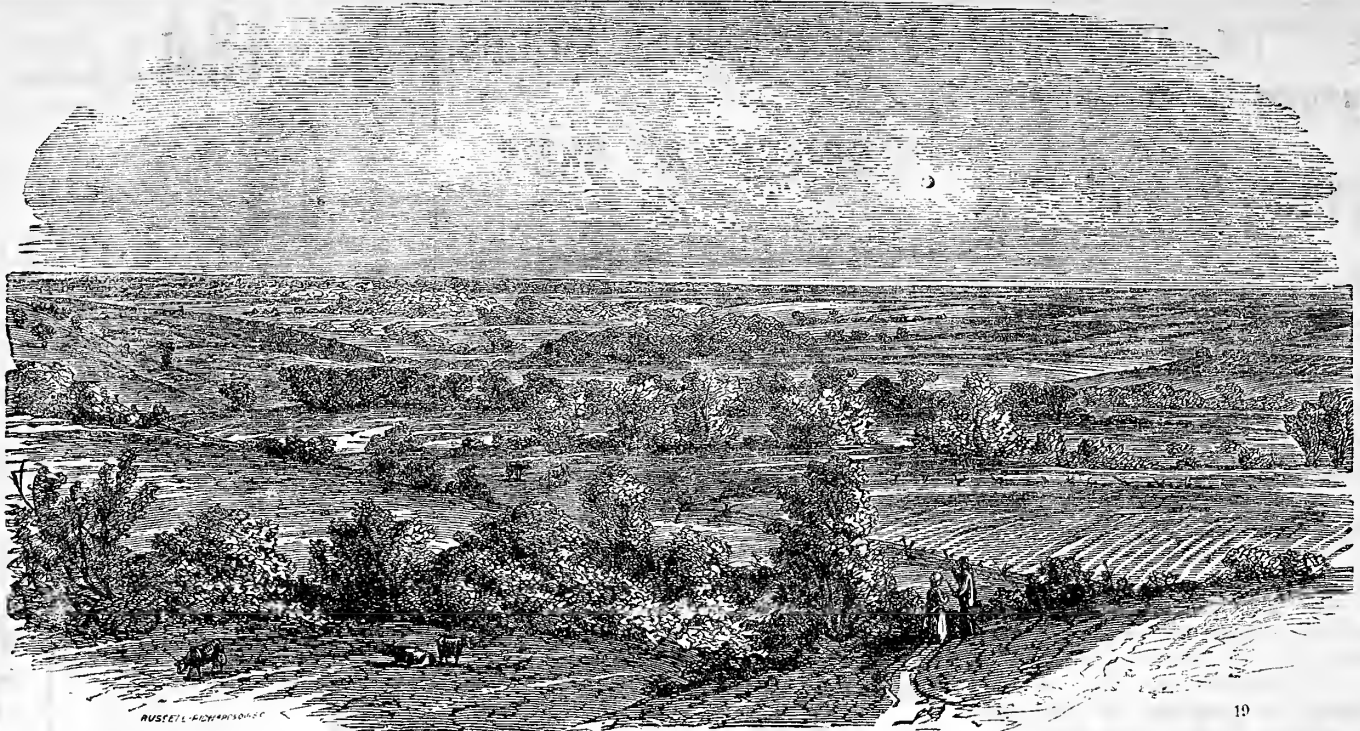

ON THE BLUE, BETWEEN CAMDEN AND CRETE,—CRETE AT THE LEFT, IN THE DISTANCE.
REPRESENTATIVE VIEW OF LANDS FOR SALE BY THE BURLINGTON AND MISSOURI RIVER RAILROAD COMPANY.

**IF YOU WANT A FARM OR HOME,
YOU SHOULD BUY OF THE
BURLINGTON AND MISSOURI RIVER RAILROAD CO.**

- BECAUSE**—Their prices are low, ranging for the best land from Three to Ten Dollars per acre.
- BECAUSE**—No payments are required of the purchaser for four years, except interest at six per cent.
- BECAUSE**—After the expiration of four years, SEVEN YEARS are allowed for payment of the principal.
- BECAUSE**—You are not obliged to go into a wilderness, but into a well-settled State, the population of which is rapidly increasing.
- BECAUSE**—The mildness of the climate and fertility of the soil is such that the settler can pay for his farm from the products raised upon it long before the time when the principal becomes due.
- BECAUSE**—Failure of crops from drought is unknown.
- BECAUSE**—Large allowances are made upon fare and freight, thus giving low rates on both to purchasers of this Company's lands.

AND YOU SHOULD BUY THIS YEAR.

BECAUSE—Purchasers during 1874 who cultivate one-half their land within two years from their purchase are allowed a reduction of twenty per cent on the price of their land.
LARGE DISCOUNTS also, FOR CASH, within One, Two, or Three Years.

Send for Circulars, with full information on all points, to

GEO. S. HARRIS, Land Commissioner,
At Lincoln, Nebraska, for land in Nebraska. At Burlington, Iowa, for land in Iowa.
JAS. R. WOOD, General Agent, 59 Clark St., Chicago, Ill.

Or to **W. D. COWLES**, General Agent, 317 Broadway, New York.



Agents wanted for
WATERS' TREE PRUNER.

Send for Circular and Price List, to
E. S. LEE & Co.,
Box 642,
Rochester, N. Y.



Price, with 4 foot pole.....	\$2.50
" " 6 " "	2.75
" " 8 " "	3.00
" " 10 " "	3.25

Samples C. O. D. or on receipt of price.
Sugar Cane and Sorgo Machinery,
Steam Engines, Horse Powers,
Farm Mills, etc.
Manufactured by
GEO. L. SQUIER & BRO.,
Buffalo, N. Y.
Catalogues free.

**Lovejoy's New Style
GLASS CUTTER
AND PUTTY KNIFE**

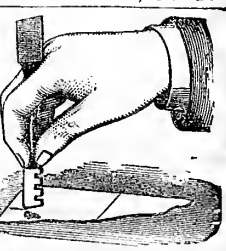

Cuts glass better than a diamond. Everybody should have one. Any child can use it. Sent to your address on receipt of 50 cents and stamp by
ALVAN L. LOVEJOY
229 Washington St.,
Boston, - - - Mass.
Liberal discount made to dealers.

BETTER THAN A GOLD-MINE.
Farmers, Teachers, Men and Women! we want some one to act for us in every Co. Good wages and expenses; situations permanent. This is the opportunity of a lifetime. Write at once to
RICE & CADWELL, 71 Dearborn St., Chicago, Ill.



Goodenough
Horse-Shoe.

Cheapest and
Best. All fitted
for Use. No
Fires required.
Send for Circulars.
Box 3,044, P. O.,
New York.

Taylor's Rotary Engine.
Excelisior Portable and Agricultural Engines. Vertical Engines and Boiler. Circular Saw-mills. Diamond State Separators. Horse Powers. Improved Herman Horse Rakes. Lime Spreaders. Send for Circulars.
Address **TAYLOR MANUFACTURING CO.,**
Westminster, Md.
Agents wanted.



Capron's Improved Turbine WATERWHEEL.
POLISHED & DETACHABLE BUCKETS
CHEAPEST & BEST WHEEL MADE.
CAPRON WATERWHEEL CO. HUDSON, N.Y.



For full particulars, address
ENGLE, KELLER & CO., Lancaster, Pa.

Farm Nursery & Apiary
FOR SALE OR LEASE.

300 acres of fine farming lands, two-story brick dwelling, 7 large rooms, commodious out-buildings, water, timber, and blue-grass plenty. Cumberland Nurseries—50 acres; complete assortment of nursery stock; with a good trade established. 300 colonies of pure Italian bees, in Langstroth's improved hives, and 20 choice Queens. Location 9 miles of Nashville, at junction of two R.R. Address
T. B. HAMLIN, Edgefield Junction, Davidson Co., Tenn.

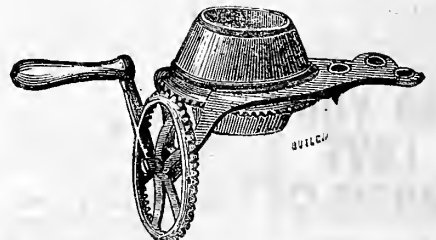

The Home Corn-Sheller.

The best hand-sheller for family use in the market.
EVERY MACHINE WARRANTED!
PRICE \$3.50. Every Farmer and Poultry Raiser should have it. Agents wanted to sell on commission. Profits large. Address for Descriptive Circulars, etc.,
LIVINGSTON & CO., Pittsburgh, Pa.

New Scheme of Easy Payments

FOR

MASON & HAMLIN

CABINET ORGANS.



The MASON & HAMLIN ORGAN COMPANY have arranged a new system, under which they now offer their well-known Organs For Rent, with Privilege of Purchase, at prices and on terms extraordinarily favorable.

Payments may run through one to four years. All Rent which has been paid allowed and deducted on Organs purchased and paid for within one year.

An Organ may be returned after six months at cost of only reasonable rent, if for any reason it is not wanted longer. If an Organ be retained, and rent paid four years, it becomes the property of the party hiring, without further payment.

Organs will be rented on this plan to any part of the country accessible to our warehouses or agencies. Only knowledge of the unrivaled excellence of our Organs, and practical experience that they will be found so attractive in use that scarcely any of them will ever be returned, warrant this offer to supply them on such terms.

Terms of Renting, containing full particulars, with descriptions of Styles, Rents, and Prices; also, Illustrated Catalogues and Testimonial Circulars, sent Free. Address

MASON & HAMLIN ORGAN CO., BOSTON, NEW YORK, OR CHICAGO.

THE PATENT

ARION PIANO-FORTE

Excels all others in Tone and Durability, and in Elegance of Finish they are Unsurpassed.

These Pianos are used exclusively in the New York Conservatory of Music, and are recommended by the Profession and the Press throughout the United States.

Before purchasing, write for Illustrated Pamphlet, and mention the Agriculturist.

ARION PIANO-FORTE CO., No. 5 East 14th Street, New York City.

NO. 10. HOWE'S PIANO & VIOLIN

or Flute Duets contain: Poet and Peasant Overture, Gentle Spring Waltzes, and 20 other pieces of music, 75 cts.; No. 10 Quintette Quadrille Band, \$6 for 5 parts, \$9 for 9 parts. Quintuple Musicians Omnibus, 4000 pieces of music for violin, flute, etc., \$5. Howe's Full Quadrille Orchestra, 150 Waltzes, Quadrilles, Galops, etc., by Strauss, Gungl, Zikoff, Faust, etc., for 9 instruments, 50 cts. each set. ELIAS HOWE, 103 Court Street, Boston, Mass. Sent post-paid. Send for catalogue.

DO YOU LOVE MUSIC? If so, send us your address and the names of your musical friends, to whom we will mail, post-paid, our new Descriptive CATALOGUE of choice MUSIC and specimen copies of the "MUSICAL WORLD," containing \$1.00 worth of Music. S. BRAINARD'S SONS, Cleveland, Ohio.

New Way to Sell a Book.

Agents are doubling their sales on this plan. Address E. C. FISHER & CO., No. 43 Beekman St., New York.

WANTED to employ reliable persons everywhere to represent our firm. Merchants, farmers, ministers, teachers, etc., etc. Good wages guaranteed. Address Hudson River Wire Co., 125 Maiden Lane, N. Y., or 18 Clark St., Chicago, Ill.

WATERS' CONCERTO and ORCHESTRAL ORGANS

are the most beautiful in style and perfect in tone ever made. The CONCERTO and ORCHESTRAL STOPS are the best ever placed in any Organs. They are produced by an extra set of reeds, peculiarly voiced, the EFFECT of which is MOST CHARMING and SOUL-STIRRING, while the IMITATION of the HUMAN VOICE is SUPERB. These Organs are the best made in the U. S.

WATERS' NEW SCALE PIANOS

have great power and a fine singing tone, with all modern improvements, and are the best Pianos made. These Organs and Pianos are warranted for 6 years. Prices extremely low for cash or part cash, and balance in monthly or quarterly payments. Second-hand instruments taken in exchange. GREAT INDUCEMENTS to the TRADE. AGENTS WANTED for every City and County in the U. S. and Canada. A large discount to Teachers, Ministers, Churches, Schools, Lodges, etc. ILLUSTRATED CATALOGUES MAILED. HORACE WATERS & SON, 461 Broadway and 48 Mercer St., New York.

THE INTER-OCEAN,

The Leading Republican Paper in the Northwest.

A Folio Paper, containing Forty Large Columns of Reading Matter.

AS A LITERARY, COMMERCIAL, AND FAMILY PAPER

It is unexcelled by any in the country.

DAILY.....\$12.00 per year. WEEKLY..... 1.50 per year

The American Agriculturist and the INTER-OCEAN. By special arrangement with the Publishers, the WEEKLY INTER-OCEAN, \$1.50 per year, and the American Agriculturist, \$1.50 per year, will be sent to one address for \$3.25.

Sample copies sent FREE. Address

INTER-OCEAN, 119 Lake St., Chicago, Ill.

AGENTS WANTED FOR THE CENTENNIAL GAZETTEER OF THE UNITED STATES.

A complete encyclopaedia of all the States, counties, townships, cities, villages, post-offices, mountains, rivers, lakes, etc., with their climate, population, agriculture, manufactures, mining, commerce, railroads, capital, education, government, and history, showing the gigantic results of the FIRST 100 YEARS of the REPUBLIC.

Agents make \$100 to \$300 per month. Send for circular. ZIEGLER & MURPHY, Philadelphia, Pa.; Cincinnati, O.; St. Louis, Mo.; Springfield, Mass.; Chicago, Ill.

Scribner's Lumber & Log-Book.

OVER HALF A MILLION COPIES SOLD. This book is the most full and complete book of its kind ever published. It gives correct measurement of all kinds of lumber, logs, plank, cubical contents of square and round timber, stave and heading bolt tables, wages, rent, board, capacity of cisterns, cord-wood tables, interest, etc., and has become the Standard Book throughout the United States and Canada.

Be sure and get the New Edition, with Doyle's Log-Table. Ask your bookseller for it, or I will send one for 35 cents, post-paid. G. W. FISHER, P. O. Box 233, Rochester, N. Y.

Grand Offers. The Ladies' Own Magazine

a year, and two superb Chromos in 17 Oil Colors, "Just One," by Hays, and the "Old Oaken Bucket," by Harvey, for \$2.50; or the Magazine and either Chromo for \$2. Cash Commission.—Both Chromos and Sample Magazine to Agents only 60 cents; or 1 Chromo and Sample Magazine 40 cents. M. C. BLAND & CO., Publishers, 208 Broadway, N. Y.

AGENTS WANTED. GRAND BOOKS:

Cyclopedia of Things Worth Knowing. 25,000 wants supplied. All you want to know about Farming, Gardening, Mechanics, Housekeeping, etc., etc. THE POPULAR FAMILY BIBLE. With Bible Dictionary and 500 Illustrations. The handsomest Bible made. THE VOICE OF GOD. A beautiful volume for every home. Terms, circulars, etc. MILLER'S BIBLE & PUB. HOUSE, 1102 & 1104 Sansom St., PHILADELPHIA, PA.

NIAGARA FIRE INSURANCE COMPANY,

201 Broadway, N. Y. Capital Stock.....\$500,000 Cash value of Assets.....\$1,368,224 Total Liabilities..... 82,602

Net Assets.....\$1,285,622 Dwellings and Farm Risks a specialty at all our Agencies. HENRY A. HOWE, President. P. NOTMAN, V. P. and Sec'y.

THE PENN MUTUAL LIFE INSURANCE COMPANY OF PHILADELPHIA.

ASSETS ACCUMULATED, \$4,427,996.96. The Penn is a purely mutual Company. All of its surplus premiums are returned to the members every year. Dividends may be applied to reduce the premium or increase insurance as desired. SAM'L C. HUEY, Pres. General and Local Agents wanted in the Middle and Western States. Apply to H. S. STEPHENS, Vice Pres., No. 924 Chestnut Street, Philadelphia, Pa.

Broken National Bank-Notes

bought. Two per cent premium. Full printed lists furnished free. DE HAVEN & TOWNSEND, successors to De Haven & Bro., 40 So. 3d St., Philadelphia, Pa.

AMERICAN AGRICULTURIST PATENT DEPT. The United States of America. TRADE MARK. ALL TO WHOM THESE PRESENTS SHALL COME. I HEREBY CERTIFY THAT THE ABOVE NAMED PARTY IS THE INVENTOR OF THE ABOVE NAMED PATENT. JAMES H. HAYES, Sec'y. PATENT DEPARTMENT. AMERICAN AGRICULTURIST. PATENT DEPT.

IMPORTANT TO INVENTORS.

American Agriculturist PATENT DEPARTMENT

In compliance with the request of numerous inventors, we have organized a

PATENT DEPARTMENT

in connection with this office for the transaction of all business connected with

Securing Patents

in the United States and foreign countries.

The character for

Reliability

which has been maintained by the AMERICAN AGRICULTURIST for more than thirty years will be carefully guarded in this as in other departments.

All Inventors

desirous of procuring patents at moderate cost are invited to forward (express prepaid) a model of their invention, with a brief description of its working. The model should not exceed one cubic foot in dimension. Upon receipt of model an opinion as to patentability will be given free of charge.

Preliminary Examination

at the Patent Office, to determine patentability, will be promptly made for a fee of \$5.

Litigation of Patents.

The services of the best counsel have been secured to prosecute or protect before the U. S. Courts and the Patent Office the claims of those intrusting their business to this agency.

Specifications, drawings, engravings, models, and all other appliances furnished at moderate prices.

In all dealings with this Department inventors may depend upon promptness, fidelity to their interests, and the best services which can be rendered by thorough experts. For full particulars, address

AMERICAN AGRICULTURIST PATENT DEPARTMENT, ORANGE JUDD COMPANY, 245 Broadway, New York.

PAINT!

DO YOU

Want to Make Money?

IF SO, PAINT YOUR HOUSE WITH THE
New York Enamel Paint,
AND SAVE 50 PER CENT.

WHITE, BLACK, AND ALL OTHER SHADES
MIXED READY FOR USE.
Will last three times as long as paint mixed in the ordinary way. Send for sample cards and price-lists.
N. Y. ENAMEL PAINT CO.
Office: 43 Chambers Street, New York.

ESTABLISHED 1837.



We offer the above brand of White Lead to the public with the positive assurance that it is

PERFECTLY PURE.

For sale by dealers generally.

ECKSTEIN, HILLS & CO.,
CINCINNATI, OHIO.

NOTE—Consumers will consult their INTEREST by bearing in mind that a large proportion of the article sold as PURE WHITE LEAD is adulterated to the extent of from 50 to 90 per cent; and much of it does not contain a particle of Lead.

Every Man His Own Painter.

NEW JERSEY ENAMEL PAINT COMPANY,

MANUFACTURERS OF

LIQUID ENAMEL PAINT,

BRADLEY'S PATENT.

In pure white, and any shade, tint, or color desired. Put up in 1, 2, 3, 4, 5, 10, 15, 20, and 40 Gallon Packages. Mixed ready for use. Are easily applied by any one. Require no mixing or addition of dryers. For sample color-card and price-list address

NEW JERSEY ENAMEL PAINT CO.,
Raritan, New Jersey.



LOVEJOY'S METALLIC WEATHER HOUSES

Indicate the changes in the weather, and are pretty mantel ornaments. The little lady appears in fair and the man in stormy weather, and they never make mistakes. Sent prepaid to any address, safely packed, upon receipt of \$2 (Two), by **ALVAN L. LOVEJOY,** Proprietor and Manufacturer, 229 Washington St. Boston.

Special price to dealers.

ONLY 5 CENTS EACH.

Something New. Lots of Fun.

The Great Puzzles—Robinson Crusoe—Washington Puzzle—Rip Van Winkle—Horse that Jack Built—Historical Puzzle—Boston Tea-Party—Mustang Puzzle—Man and Cat—Jack and Bean-Stalk—Comical Transformations—Wonderful Donkeys—Naughty Chinee—Invisible Horse. 5 cents each. Six assorted for 25 cents. Package containing over one dozen different Puzzles for 50 cents. Sent everywhere on receipt of price. Address

PUZZLE COMPANY, 755 Broadway, New York City.

FIRST Premiums awarded by Amer. Inst., 1870. MICROSCOPES.

Illustrated Price-List sent free on application.

MAGIC LANTERNS.

Catalogue, priced and illustrated, sent free.

T. H. McALLISTER, Optician, 49 Nassau-st., N. Y.

CANARY BIRDS.—How to take care of them, and if sick how to cure them. A little work mailed gratis on application with a postage stamp. Address **Grinton's New York Florist, Seed, and Bird Depot,** 67 Chippewa Street, Buffalo, N. Y.

THE EXCELSIOR LAWN MOWER

FOR HAND OR HORSE POWER.



Manufactured by **Chadborn & Coldwell M'f'g Co.,**
(Send for Circular.) **NEWBURGH, N. Y.**

No More Loose Bolts and Nuts.

THE CELEBRATED "CUMMING" LOCK-NUT, Patented June 16, 1868.

No More Rattling **CARRIAGES** and **WAGONS.**
No More Dropping Down of **SHAFTS.**
No More Lost Bolts from **REAPERS** and **MOWERS.**

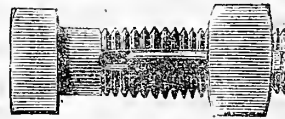

No More Flying Teeth from **THRESHERS.**
No More Bills for Repairs Continually.
SEND FOR PRICE-LIST AND CIRCULARS TO

THE LOCK-NUT AND BOLT CO. OF N. Y., No. 61 Broadway, New York.

Licenses granted to Manufacturers of Agricultural Machines, Carriages, etc.

Samples from
B. E. Hale & CO.,
56 and 58 Park
Place, N. Y.
Sole Agents for
Eastern States.

BUILDING PAPER!

FOR SHEATHING, ROOFING, DEAFENING, CARPET LINING, AND PLASTERING!

Samples from
Rock River Paper
Company,
Chicago, Ill.

J. P. Gillett
STEEL PENS!

Sold by all Dealers.

No. 91 JOHN ST., NEW YORK.

HENRY HOE, Sole Agent. **JOSEPH GILLOTT & SONS.**



REMINGTON'S

Sporting, Hunting, and Target
Breech-Loading

Rifles & Shot Guns.

Also, Revolving, Repeating, Deringer, and
Vest Pocket

PISTOLS and RIFLE CANES.

OR

Double-Barrel Breech-Loading Gun

IS NOW READY.

The best ever offered, containing all the most desirable features of the best imported, together with some valuable improvements peculiar only to this gun. Top Snap action, half-cocked, breech opened and shells extracted by one motion.

E. REMINGTON & SONS,
281 and 283 Broadway, N. Y.

OR, ARMORY, ILION, N. Y.

CUT THIS OUT AND SEND FOR ILLUSTRATED PRICE LIST.

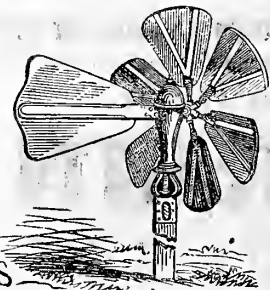

Automatic PUMPS.

Water driven to any height and distance by compressed air. Country houses supplied cheaply and certainly for bath-rooms, water closets, hot and cold water faucets, etc. Plenty of fresh water for stock on farms.

Address
HARTFORD PUMP CO.,
41 Trumbull St.,
Hartford, Conn

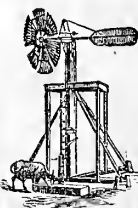

Halladay's Improved

Wind-Mill.

PERFECTLY Self-Regulating. The Best, Cheapest, most Durable and Popular Mill made. Manufactured under the immediate supervision of inventor 18 years. Two million dollars' worth now in use. Send for Catalogue.

U. S. WIND ENGINE & PUMP CO.
BATAVIA, ILL.

The Banner Windmill

Has proved itself the most reliable and perfect Windmill in use. Trial and warranty always given. Circulars free. Rare chance for agents.
N. P. MIX, Columbus, O.
Hocking Valley M'f'g Co., Lancaster, O.

MARTIN'S IMPROVED

Brick Machine.

Adopted and used by the leading Brick manufacturers. Made and sold by the
AMES M'F'G CO., Chicopee, Mass.

Brick and Tile Machines.

For circulars address **J. W. PENFIELD,** Willoughby, Lake Co., Ohio.

Standard Architectural Books for Carpenters and Builders.



Monckton's National Builder and Stair-Builder.—A new and original work, covering every practical branch of Constructive Carpentry, with 1,000 Working Scale Drawings, in two colors. Showing the simplest methods of finding all Joints and Forms; method of constructing all varieties of French Roof; all other methods of Roofing, all styles of Framing; Splayed Work, Ceilings, Domes, Niches, Raking and Level Moldings, etc., with a Treatise on Stair-Building and Hand-Railing, and Designs for Stair-Cases, Newels, Balusters, and Hand-Rails. One royal quarto volume, uniform with "Woodward's National Architect." Post-paid, \$12.00.

The above work is also divided and published in two volumes as follows:

Monckton's National Stair-Builder.—Is a complete work on Stair-Building and Hand-Railing. Fully explained and illustrated by large scale diagrams, in two colors, with designs for Staircases, Newels, Balusters, and Hand-Rails. Royal Quarto. Post-paid, \$6.00.

Monckton's National Carpenter and Joiner.—A complete work, covering the whole science of Carpentry, Joinery, Roofing, Framing, etc., fully explained and illustrated by large scale diagrams in two colors. Royal Quarto. Postpaid, \$6.00.



Woodward's National Architect.—1,000 Designs, Plans, and Details for Country, Suburban, and Village Houses; with Perspective Views, Front and Side Elevations, Sections, Full Detail Drawings, Specifications, and Estimates. Also, Detail Drawings to Working Scale, of Brackets, Cornices, French Roofs, Sectional and Framing Plans of French Roofs, Dormer-Windows for French Roofs, Bay-Windows, Verandas, Porches, Plaster Finish, Cornices, Ceilings, Hard-wood Mantels, and all that is required by a Builder to design, specify, erect, and finish in the most approved style. One superb quarto volume. Post-paid, \$12.00.

Woodward's Cottages and Farm Houses.—188 Designs and Plans of low-priced Cottages, Farm Houses, and Out-Buildings. Post-paid, \$1.50.

Woodward's Suburban and Country Houses.—70 Designs and Plans, and numerous examples of the French Roof. Post-paid, \$1.50.



Woodward's Country Homes.—150 Designs and Plans, with Description of the Manner of Constructing Balloon Frames. Post-paid, \$1.50.

Woodward's Graperies and Horticultural Buildings.—Designs and Plans of Hot-Beds, Cold-Pits, Propagating Houses, Forcing Houses, Hot and Cold Graperies, Green Houses, Conservatories, Orchard Houses, etc., with the various modes of Ventilating and Heating. Post-paid, \$1.50.

Wheeler's Rural Homes.—Houses suited to Country Life. Post-paid, \$2.00.

Wheeler's Homes for the People.—100 Original Designs, with full Descriptions, and Constructive and Miscellaneous Details. Post-paid, \$3.00.

Harney's Barns, Out-Buildings, and Fences.—Containing Designs and Plans of Stables, Farm Barns, Out-Buildings, Gates, Gateways, Fences, Stable Fittings and Furniture, with nearly 200 Illustrations. Royal quarto. Post-paid, \$10.00.

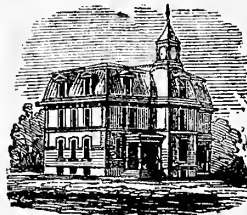

Eveleth's School-house Architecture.—A new and original work, containing Seventeen Designs for School-houses, Sixty-seven Plates with Perspectives, Elevations, Plans, Sections, Details, Specifications all drawn to working scale, with methods of Heating and Ventilation. Large quarto. Post-paid, \$10.00.

Copley's Plain and Ornamental Alphabets.—Giving examples in all styles, together with Maps, Titles, Borders, Meridians, Ciphers, Monograms, Flourishes, etc., adapted for the practical use of Surveyors, Civil Engineers, Draughtsmen, Architects, Sign Painters, Schools, etc. Post-paid, \$3.00.

Beckwith Sewing Machines

ONLY \$12.

ONLY \$20.

We have offered as a Premium, and also for sale, for more than a year past, the

Beckwith Sewing Machine,

which has been fully described in previous numbers of this paper. We have already given and sold more than one thousand of these machines, and testimonials of satisfaction have come from every quarter.

We still offer the **Beckwith Sewing Machine, Improved**, price \$12. A new and very simple braiding-foot has been made, by which a child can sew on braid without the least trouble, following any desired pattern with ease; also a new arm, spiral spring and lever for raising the presser-foot, all of which are now set in a position that leaves the needle free to be threaded. The joint is much enlarged, and the machine is otherwise greatly strengthened and improved. The use of the braider-foot alone will be valued more than the cost of the machine.

Each of these machines is put in a neat, compact box, with *hemmer and guide, oil-can with oil, thread, different-sized needles, etc.*, with full Printed Directions for using. On receipt of \$12 we will send one of these machines to any address, expressage to be paid by the purchaser.

The Machine as a Premium.

We will give one of these \$12 machines to any one who will collect and forward eight subscribers for *Hearth and Home* one year at \$3 each; or sixteen subscribers to *American Agriculturist* for one year, at \$1.50 each, expressage on the machine to be paid by the recipient of it.

THE BECKWITH

PORTABLE

Family Sewing Machine.

PRICE \$20.

Enlarged and Improved.

ITS WEIGHT IS 7 POUNDS.

While we continue the offer of the Improved \$12 Machine as heretofore, we now offer the new

Portable Family Machine,

price \$20, which comprises all the excellencies of the former, with many valuable improvements. Its size and power are increased, and its capacity thus very much enlarged, without impairing its portability. There have been added cam and eccentric movement, a balance-wheel, and also an oscillating needle-clamp, by which the length of stitch can with the greatest ease be changed to the finest shade of variation without touching the needle.

To any one sending us \$20, we will send one of the Machines (packed in a neat, portable case, with handle to carry it easily), expressage to be paid by purchaser.

The Machine as a Premium.

We will give one of these \$20 Machines to any one who will collect and forward to us Fifteen Subscribers to *Hearth and Home* for one year at \$3 each, or Thirty Subscribers to *American Agriculturist* for one year at \$1.50 each, or One Hundred at \$1 each, expressage on the Machine to be paid by the recipient of it.

Almost any lady can readily secure the small number of subscribers required to get either the \$12 or the \$20 Machine as described above; or some friend can thus obtain it for her as a present.

ORANGE JUDD COMPANY,

245 BROADWAY, NEW YORK.

ORANGE JUDD COMPANY, Publishers, 245 Broadway, New York.

Newly Revised and Enlarged Edition.

Practical Floriculture.

A Guide to the Successful Propagation and Cultivation of Florists' Plants.

By PETER HENDERSON, Author of "Gardening for Profit."

Beautifully Illustrated. Price, Post-paid, \$1.50.

In this work, which has everywhere become so deservedly popular, not only is the whole "art and mystery" of propagation explained, but the reader is taught how to plant and grow the plants after they have been propagated.

The following are a few of the subjects embraced in the latest edition:

Laying out Flower Garden and Lawn; Designs for Grounds and for Greenhouses; Soils for Potting; Cold Frames; Hot-Beds; Greenhouses Attached to Dwellings; Modes of Heating; Propagation of Plants by Seeds and by Cuttings; Culture of the rose and Tuberosc; Growing of Winter-flowering Plants; Construction of Bouquets, Baskets, etc.; Parlor and Window-Gardening; Wardian-Cases and Ferneries; Insects; What Flowers Grow in the Shade; Culture of Grape-Vines under Glass; The Profits of Floriculture; How to Become a Florist, etc., etc.

THE ILLUSTRATED Book of Poultry,

With Practical Schedules for Judging, Constructed from Actual Analysis of the Best Modern Decisions.

By LEWIS WRIGHT,

Author of "The Practical Poultry Keeper," "The Brahma Fowl," etc.

ILLUSTRATED WITH Fifty Colored Portraits of Prize Birds,

Painted from Life by J. W. Ludlow.

CONTENTS.

Table with 2 columns: CHAP. and descriptions of poultry breeds and management topics like 'Horses and Accommodation', 'The Selection of Stock', 'Brahmas', 'Malays', etc.

Price, Postpaid - - - \$15 00

Either of the above books sent post-paid on receipt of price by

ORANGE JUDD COMPANY, 245 BROADWAY, NEW YORK.

DO GOOD AND MAKE MONEY.

The Publishers of American Agriculturist and HEARTH AND HOME take pleasure in presenting in the adjoining Table, their new general Premium List for 1874. The Premiums which they have offered in past years have engaged the attention of a very large number of persons of all ages and both sexes.

Here is pleasant and profitable work for all. Any one who wishes to do good and make money, can do both by going to work as here invited by the publishers of these two most valuable journals, American Agriculturist and HEARTH AND HOME. You need only to show specimens of the papers, promise the beautiful Chromos, which are now ready for delivery, according to the publishers' offer, and forward your subscriptions. TRY IT.

Explanatory Notes.

N. B.

Read and carefully

Note the following items: (a) All subscribers sent by one person count, though from one or a dozen different Post-offices. But... (b) Tell us with each name or list of names sent, that it is for a premium... (c) Send the names as fast as obtained, that the subscribers may begin to receive the paper at once. You can have any time, from now until July 1st, to fill up your list... (d) Send the exact money with each list of names, so that there may be no confusion of money accounts... (e) Old and new subscribers all count in premium clubs, but a portion, at least, should be new names; it is partly to get these that we offer premiums to canvassers... (f) Specimen Numbers, etc., will be supplied free as needed by canvassers, but they should be used carefully and economically, and where they will tell... (g) Remit money in Checks on New York Banks or Bankers, payable to order of Orange Judd Company, or send Post-office Money Orders. If neither of these is obtainable, Register Money Letters, affixing stamps both for the postage and registry; put in the money and seal the letter in the presence of the Postmaster, and take his receipt for it. Money sent in any of the above ways is at our risk; otherwise it is not.

[In the following table is given the price of each article, and the number of subscribers required to get it free, at the regular rates, \$1.50 a year for American Agriculturist, and \$3.00 a year for Hearth and Home; also at the club rates of \$1 and \$2.50; also at the rates of \$4 a year for both papers together.] Description of Premiums sent free to applicants.

N. B.—It all Premium Clubs for either paper, TWO copies of American Agriculturist (English or German) at \$1.50 each, and ONE copy of Hearth and Home at \$3.00, will count exactly the same. So also two copies of American Agriculturist at \$1 each, and one copy of Hearth and Home at \$2.50, will count exactly the same. In this way Premium Clubs can be made up from the 2d and 4th columns, or from the 3d and 5th, or wholly from the 6th column.

Table of Premiums and Terms for American Agriculturist, and for Hearth and Home, for the Year 1874. Open to all—No Competition. Columns include No., Names of Premium Articles, Price of Premiums, and Number of Subscribers required at various rates.

Every Premium article is new and of the very best manufacture. No charge is made for packing or boxing any article in our Premium List. The Premiums, Nos. 2 to 8, 27 to 33, 55 to 78, and 81 to 93, inclusive, will each be delivered FREE of all charges, by mail or express (at the Post-office or express office nearest the recipient) to any place in the United States or Territories.—The other articles cost the recipient only the freight after leaving the manufactory of each, by any conveyance desired. Description of Premiums sent free to applicants.

PLANTS.

Our Plants, for health and vigor, can not be surpassed. The impression conveyed by the many complimentary letters we have received the past year is, that our Plants are superior in size and quality to those generally received from Nurseries. We have only space for a few of those letters in our Catalogue.

Our collection of Plants will be found rich in popular varieties, such as Roses, Geraniums, Fuchsias, and many other favorites.

SEEDS.

**Garden Seeds,
Field Seeds,
Flower Seeds.**

Of the best and most popular kinds, and of undoubted quality, having been selected from the most reliable growers in the world, and fully tested by us. We call particular attention to our **One, Two, Three, and Five Dollar Collections of SEEDS**, as set forth in our Catalogue.

ROSES.

Our collection of Roses embraces the best kinds of **Hybrid Perpetual, Moss, Bourbon, China,** and **Ever-blooming Tea-Scented Varieties.** They are all grown in pots, and ready for immediate flowering. Can be sent by mail with perfect safety. We will send six choice sorts, safely packed, by mail on receipt of \$1.00, or twelve choice sorts, including one Moss Rose, on receipt of \$2.00. If the selection is left to us we will send such as will give constant flower the whole season.

Geraniums.

Our collection of Geraniums is unrivaled, and includes the splendid varieties, **Master Christine, Jean Sisley,** and the beautiful Double Pink Variety, **Marie Lemoine.**

We send twelve beautiful varieties by mail for \$2.00, each twelve to include a plant of either one of the above varieties the parties ordering may select. We also send six sorts by mail for \$1.00. We offer the new Double White Geranium, **Aline Sisley,** at \$1.00 each. We also offer five other **Beautiful New Double Varieties,** some of them of quite new and remarkable colors—for full description of which, with many other new plants, see our Catalogue. We also make some splendid special offers in Geraniums, which we are enabled to do from our immense stock.

In our Catalogue will also be found a fine collection of new and older

Fuchsias,
Carnations, Verbenas, Dahlias,
Chrysanthemums, Phloxes,

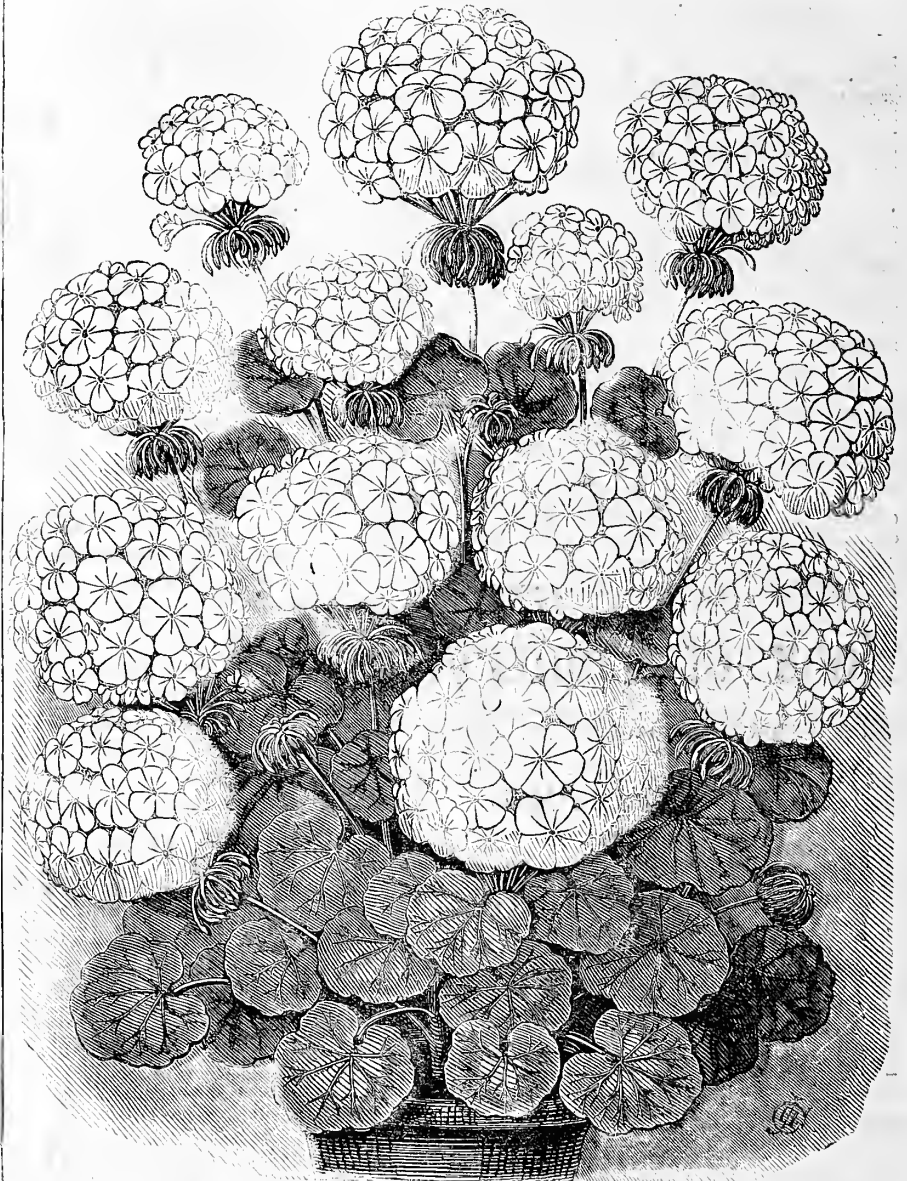

Pelargonium—Master Christine.

Six beautiful new varieties of COLEUS, with a full assortment of Greenhouse and Bedding Plants. Sent everywhere by mail or express.

For our CATALOGUE inclose Letter-Stamp to the

BELLEVUE NURSERY COMPANY,

PATERSON, NEW JERSEY.

HENRY E. CHITTY, Supt.

OUR NEW CHROMO,

ENTITLED

"Look Out!"

A Beautiful, New Picture

FOR EVERY SUBSCRIBER

TO

Hearth and Home

FOR 1874.

Another fine Oil Painting has been executed by Mr. Reinhart for the Publishers of HEARTH AND HOME. It has also been reproduced with great success in Chromo. This Picture, which is entitled "LOOK OUT!" is finely colored, and the same in size as the Chromo "Up for Repairs," which has been executed for subscribers to the *American Agriculturist*. It is designed as a Present for ALL Subscribers to HEARTH AND HOME for the year 1874, received after this date, including single subscribers, those in Clubs, etc.

It will be delivered at 245 Broadway free of charge. If to be sent by mail, 10 cents must be furnished to prepay packing and postage. **For 25 cents it will be Mounted, Varnished, Packed, and sent Prepaid to subscribers to HEARTH AND HOME for 1874.**

N. B.—The Chromo will be delivered:

At the office, **Unmounted**,.....Free.
 " " **Mounted**,.....15 cts. extra.
 If sent postpaid, **Unmounted**,...10 cts. extra.
 " " **Mounted**,.....25 cts. extra.

"THE STRAWBERRY GIRL."

A few of the beautiful pictures, "The Strawberry Girl," which have been given to thousands of subscribers, are still in stock, and, while any remain, subscribers to HEARTH AND HOME can have their choice between this and the new Chromo, "Look Out!"; but the choice must be named at time of subscribing, and if the first is taken, **50 cts. extra**, instead of 25 cts., must be sent for mounting, packing, and prepayment.

The price of HEARTH AND HOME is \$3 a year, or \$4 secures HEARTH AND HOME and *American Agriculturist*.

\$3.25 will pay for HEARTH AND HOME and New Chromo mounted, and Chromo will be packed and sent, prepaid, to the subscriber. (\$3.50 if Chromo "Strawberry Girl" is taken instead of "Look Out!")

\$1.75 will pay for *American Agriculturist* and Chromo, mounted, and Chromo will be packed and sent, prepaid, to the subscriber.

\$4.50 will pay for *American Agriculturist* and HEARTH AND HOME together, with both Chromos, mounted, and Chromos will be sent, prepaid, to subscriber. (\$4.75 if Chromo "Strawberry Girl" is taken.)

SUBSCRIBE NOW.

Secure Both Papers. Secure Both Pictures. Get your Neighbors to Join you. Do good, Be wise, and Be happy!

ORANGE JUDD COMPANY, Publishers,
 245 BROADWAY, NEW YORK.

OUR NEW CHROMO,

ENTITLED

"Up for Repairs,"

A Beautiful, New Picture

FOR EVERY SUBSCRIBER

TO THE

American Agriculturist

FOR 1874.

The great satisfaction which has been expressed by tens of thousands of subscribers to this paper who have received the picture entitled "Mischief Brewing," has led the Publishers to provide another beautiful Gift for their patrons for the coming year.

An exquisite Oil Painting by the celebrated American Painter, Mr. B. F. Reinhart, executed expressly for the *American Agriculturist* and entitled

"UP FOR REPAIRS,"

has been most successfully reproduced in Chromo by the well-known firm of Bencke & Scott. It is a picture of a scene in childhood, which many will recognize as what they have themselves witnessed or been actors in, and can not fail to please both old and young. The Chromo is so perfectly done as scarcely to be distinguished from the original.

The Publishers will give this beautiful Chromo

To Every Subscriber

to this paper for the year 1874 received after this date, as detailed below. It is ready for immediate delivery at 245 Broadway, Free of Charge.

If to go by mail, 10 cents must be sent to cover cost of packing and postage. **For 25 cents it will be Mounted, Varnished, Packed, and sent Post-paid.**

N. B.—The Chromo will be delivered:

At the Office, **Unmounted**, Free.
 " " **Mounted**, 15 cents extra.
 Sent by Mail, **Unmounted**, 10 cents extra.
 " " **Mounted**, 25 cents extra.

We advise all to have them mounted before leaving the office, as in the large quantities we put up we are able to mount them for a quarter of the cost of doing it singly, and better than it can usually be done elsewhere.

The picture is designed for every subscriber upon the terms stated above, which please read carefully; and on these terms all are alike entitled to it, whether their names come singly at \$1.50 each, or in Clubs of Four for \$5, or Clubs of Ten at \$1.20 each, or in Clubs of Twenty or more at \$1 each. Subscribers in Premium Clubs will also thus be entitled to it.

N. B.—A few of the beautiful pictures entitled "MISCHIEF BREWING," which have been given to so large a number of subscribers, are still in stock, and, while any remain, subscribers to the *American Agriculturist* can have their choice between this and the new Chromo "UP FOR REPAIRS;" but the choice must be named at time of subscribing.

Subscribe Now.

ORANGE JUDD COMPANY,
 245 BROADWAY, NEW YORK.

FRAMES

FOR THE CHROMOS.

We have made arrangements to supply frames to our subscribers who may desire them for the Chromos which are now being distributed. Many will no doubt avail themselves of this opportunity to place these beautiful pictures in handsome frames at moderate cost. In all cases where sent by express, the purchaser will pay express charges. The prices of the frames are as follows:

For American Agriculturist Chromo,
 "UP FOR REPAIRS,"
 Or for Hearth and Home Chromo,
 "LOOK OUT!"

Letter A. Neat Black-Walnut Frame, Gilt Band...	\$1.15
" B. Wider, " " " " " " " " " " " "	1.75
" C. Rieher Style, Polished " " " " " " " "	2.75
Letter D. Full Gilt Frame, 2 inches wide.....	\$1.50
" E. " " " " 2½ " " " " " " " " "	2.00
" F. Belgian Gilt Frame 2 inches wide.....	2.50
" G. " " " " Fluted 3 " " " " " " " "	4.00

For American Agriculturist Chromo,
 "MISCHIEF BREWING."

No. 1. Neat Black-Walnut Frame, Gilt Band....	\$1.15
" 2. Wider, " " " " " " " " " " " "	1.75
" 3. Rieher Style, Polished " " " " " " " "	2.75

No. 4. Full Gilt Frame, 2 inches wide.....	\$1.50
" 5. " " " " 2½ " " " " " " " " "	2.00
" 6. Belgian Gilt Frame, 2 inches wide.....	2.50
" 7. " " " " Fluted, 3 " " " " " " " "	4.00

For Hearth and Home Chromo,

"THE STRAWBERRY GIRL."

No. 8. Neat Black-Walnut Frame, Gilt Band....	\$1.40
" 9. Wider " " " " " " " " " " " "	2.20
" 10. Rieher Style, Polished " " " " " " " "	3.25

No. 11. Full Gilt Frame 2 inches wide.....	\$1.75
" 12. " " " " 2½ " " " " " " " " "	2.50
" 13. Belgian Gilt Frame, 2 inches wide.....	3.00
" 14. " " " " Fluted, 3 " " " " " " " "	5.00

Address orders, specifying by its letter or number the frame desired, and inclosing price, as above, to the

ORANGE JUDD COMPANY,

245 BROADWAY, NEW YORK.

Play and Profit IN MY GARDEN.

By E. P. ROE,

Author of "Barriers Burned Away," etc.

NOTICES BY THE PRESS.

The author takes us to his garden on the rocky hill-sides in the vicinity of West Point and shows us how out of it, after four years' experience, he evoked a profit of \$1,000, and this while carrying on pastoral and literary labors. . . . It is very rare that so much literary taste and skill are mated to so much agricultural experience and practical good sense.—*Harper's Magazine*.

His little garden he confesses is nothing to boast of, not one of the miraculously fertile spots which, if you tickle with a plow, they laugh into a harvest, but still he managed to make it produce the value of \$2,000 in a single summer, and it might have been more but for sundry mishaps and mistakes which he found out when it was too late.—*New York Tribune*.

CONTENTS.

CHAP. 1.—Will you Walk into my Garden?	CHAP. 10.—When to Commence a Garden.
2.—My Garden Accounted for.	11.—We will go to Work.
3.—My Garden—Its Location.	12.—The Campaign in September.
4.—My Garden—How it Grew.	13.—Preparing for Winter Quarters.
5.—My Garden—What Fruits were Cultivated.	14.—Gardening Over a Winter Fire.
6.—The Same—Continued.	15.—April.
7.—Markets.	16.—Grafting or Horticultural Conversion.
8.—Expenses.	17.—Corn and Beans (Success).
9.—Ground for a Garden.	

Price, Postpaid - - - - \$1 50

ORANGE JUDD COMPANY,

245 BROADWAY, NEW YORK.

YOUNG MEN.

BOYS, & MIDDLE-AGED MEN

Trained for a Successful Start in Business Life, taught how to get a Living, Make Money, and become Enterprising, Useful Citizens. EASTMAN BUSINESS COLLEGE, Poughkeepsie, N. Y., On-the-Hudson, the only Institution devoted to this especially. The oldest and only practical Commercial School, and only one providing situations for Graduates. Refers to Patrons and Graduates in nearly every city and town. Applicants enter any day. Address for particulars and Catalogue of 3,000 graduates in business.
H. G. EASTMAN, LL.D., Poughkeepsie, N. Y.

WOOD, TABER & MORSE,
Eaton, Madison Co., N. Y.
MANUFACTURERS OF

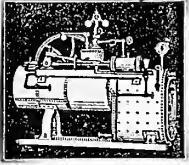

Steam-Engines,
Portable, Stationary, and
Agricultural.

Hundreds in use in Shops, Printing Rooms, Mills, Mines, and on Farms and Plantations for Grain Threshing, Food Cooking for Stock, Cotton Ginning, Sawing, etc. Circulars sent on application.

Important to Farmers.
THE BEST IN THE WORLD.

Boswell's Room Heater, Universal Dryer, and Cooking Apparatus Combined.

Send stamp for description to the General Agent,
D. C. MOORE, M.D., Youngstown, Ohio.

IF you wish to get full, reliable, and accurate information about **FLORIDA** its climate, soil, and capacities, and the profits of **ORANGE** growing, and the cultivation of Tropical Fruits, subscribe to the **FLORIDA AGRICULTURIST**, an 8-page Weekly Paper, containing 32 broad columns, devoted to the Agricultural Interests of Florida. Its home contributors include Solon Robinson, formerly of the N. Y. Tribune; ex-Gov. Bloxham; Hon. C. H. Du Pont, and many of the largest planters, \$3 a year. Address **WALTON & Co., Jacksonville, Fla.**

WE WANT TO EMPLOY a large number of first-class business men to travel only in cities and large towns, and sell our United States Law Directory. **J. B. MARTINDALE & CO., Indianapolis, Ind.**

PLANTS—PLANTS.—Affected by the late Panic in Prices only. See page 111, and address **JOHN S. COLLINS.**

\$290. Circulars free. U. S. Piano Co. 810 Broadway, N. Y.

GET THE BEST.

Gardening for Profit.

A Guide to the Successful Cultivation of the Market and Family Garden.

By **PETER HENDERSON.**

Finely Illustrated. Price, Post-paid, \$1.50.

The success of this book has probably not been equaled by that of any horticultural work of the present day. Its popularity is due to the fact that it tells just what people wish to know—the way in which the author made money by gardening—and puts in a plain, striking light all the requisites to success. The writer was not afraid to have people know that he cultivated his land for profit, and, more than that, he was quite willing that all should know and practice, if they chose, the very processes which he had found most conducive to the desired end. The late Horace Greeley said of this book: "There are marvels of transformation and rapid reproduction recorded therein which might well shame the dull fancy of the author of Aladdin or Kaloolah. There is no theory about it; a man who has made himself rich by market-gardening plainly tells our young men how they can get rich as easily as he did, and without wandering to California or Montana for it either." And tens of thousands who have read and profited by the work could give similar testimony. It is unquestionably the most thorough and the best book of its kind that has yet come from the hand of an American author.

The following is a specimen of hundreds of letters that have been received concerning this work.

I was an early purchaser of "Gardening for Profit," a reading of which made the possession of "Practical Floriculture" a necessity. I sincerely thank the writer for giv-

ing us non-professionals what we have so long needed—some plain common-sense directions for our assistance—and for having exploded some outrageous humbugs which have been perpetuated in all previous works on gardening and floriculture from time immemorial, tending to produce the conviction that nothing but professional skill could raise a vegetable or flower. **LUTHER NEWCOMB,**
May 4, 1873. Montpeller, Vt.

Money IN THE GARDEN.

A VEGETABLE MANUAL,

PREPARED WITH A VIEW TO

ECONOMY AND PROFIT,

BY **P. T. QUINN,**

PRACTICAL HORTICULTURIST.

In this work the author aims to give, in a plain, practical style, instructions on three distinct although closely connected branches of gardening—the kitchen-garden, market-garden, and field culture; the only and sufficient credentials for the fitness of his undertaking being a successful practical experience for a term of years.

CONTENTS.

- | | |
|---------------------------------|----------------------------|
| Chapter I. Money in the Garden. | Chapter VIII. Melons. |
| " II. Hot-beds. | " IX. Onions. |
| " III. Artichoke. | " X. Parsley. |
| " IV. Beans. | " XI. Radishes. |
| " V. Cabbages. | " XII. Salsify. |
| " VI. Egg-Plants. | " XIII. Tomatoes. |
| " VII. Lettuce. | " XIV. Forcing Houses. |
| | Chapter XV. List of Seeds. |

PRICE, POST-PAID ----- \$1.50
Either of the above books sent post-paid on receipt of price by

ORANGE JUDD COMPANY,
245 BROADWAY, NEW YORK.

UNION PACIFIC R.R. CO.

HAVE A LAND GRANT OF

12,000,000 ACRES!

OF THE BEST MINERAL AND FARMING LANDS OF AMERICA.

4,250,000 ACRES IN THE STATE OF NEBRASKA.

3,000,000 ACRES in Central and Eastern Nebraska,

IN THE GREAT PLATTE VALLEY,
THE GARDEN OF THE WEST,

NOW FOR SALE AT PRICES THAT DEFY COMPETITION.

Cheap Lands—The Best Investment.

No fluctuations! Always Improving in Value! The Wealth of the Country is made by the Advance in Real Estate! These lands are located on the 41st Degree of North Latitude, in the

Great Central Belt of Population, Commerce, and Wealth.

Have a mild and healthy climate, and for Grain and Fruit Growing and Stock Raising are unsurpassed by any in the United States.

The Best Market in the West,

The great Mining Regions of Wyoming, Colorado, Utah, and Nevada being supplied by the farmers of the PLATTE VALLEY.

Cheaper in Price and More Favorable Terms Given than can be Found Elsewhere.

Five and Ten Years' Credit Given, with Interest at Six per Cent.

NO ADVANCE INTEREST REQUIRED. Colonists and Actual Settlers can buy on Ten Years' Credit. Lands at same price to all Credit purchasers. Prices range from \$2.00 to \$10.00 per Acre. A Deduction of Ten per Cent for Cash. The Land Grant Bonds of the Company are taken at par in payment for the Lands.

Free Homesteads for Actual Settlers. The Best Locations for Colonies.

SOLDIERS OF THE LATE WAR are entitled to a **FREE HOMESTEAD OF 160 ACRES** within Railroad Limits, which is equal to a **DIRECT BOUNTY of \$400. DO NOT DELAY. NOW IS THE TIME TO SECURE A HOME.** Free Passes to Purchasers of Railroad Lands. Buy Through Tickets Direct to Omaha, Nebraska.

Sectional Maps, showing Lands for sale, with the prices corrected up to the latest date, also Descriptive Pamphlet with new maps published in ENGLISH, GERMAN, SWEDISH, DANISH, FRENCH, DUTCH, and BOHEMIAN, furnished gratuitously on application to the Land Department, or mailed free to any address. "THE PIONEER" is also sent FREE to applicants IN ANY PART OF THE WORLD. Address

O. F. DAVIS, Land Commissioner U. P. R.R., OMAHA, NEB.

PEAR CULTURE

FOR PROFIT.

By **P. T. QUINN,**

PRACTICAL HORTICULTURIST.

ILLUSTRATED.

If one wishes to raise pears intelligently, and with the best results, he must know first the character of his soil, the best mode of preparing it, the best varieties to select under existing conditions, the best mode of planting, pruning, fertilizing, grafting, and utilizing the ground before the trees come into bearing, and finally, of gathering and packing for market.

The hope of furnishing practical information on all these points has induced the author to endeavor to draw for others the same lessons which years of practical experience have afforded him.

Contents:

- | | |
|-----------------------------------|-------------------------------|
| Chap. I. Varieties. | Chap. IX. Varieties to Plant. |
| " II. Aspect. | " X. Pruning. |
| " III. Preparation of the Soil. | " XI. Manuring and Mulching. |
| " IV. Distance Apart in Planting. | " XII. Gathering Fruit. |
| " V. Dwarfs and Standards. | " XIII. Marketing Pears. |
| " VI. Planting-Time. | " XIV. Profits. |
| " VII. Planting. | " XV. Propagation, etc. |
| " VIII. Nursery Trees. | " XVI. Practical Suggestions. |
| | " XVII. Orchard Record. |

PRICE, POST-PAID.....\$1.00

ORANGE JUDD COMPANY,

245 BROADWAY, NEW YORK.

APRIL, 1874.

AMERICAN

AGRICULTURIST

FOR THE FARM, GARDEN & HOUSEHOLD.



Vol. XXXIII

Number 4

PUBLISHED BY THE
ORANGE JUDD COMPANY,
245 BROADWAY,
NEW-YORK.

Standard Architectural Books for Carpenters and Builders.

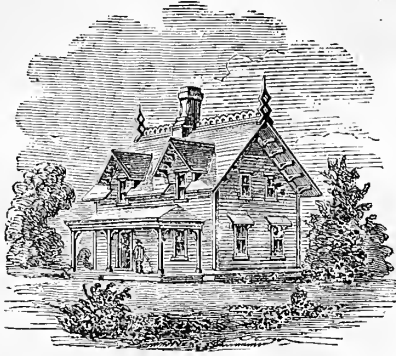

Hussey's National Cottage Architecture; or, Homes for Every One.—With Designs, Plans, Details, Specifications, and Cost; with Working Scale, Drawings complete, so that Houses may be built direct from the book. Adapted to the popular demand for practical, handsome, and economical homes. Royal Quarto. Six Dollars, post-paid.

Atwood's Country and Suburban Houses.—Illustrated with about 150 engravings. Hints and Suggestions as to the General Principles of House-building, Style, Cost, Location, etc. Post-paid, \$1.50.

Monckton's National Stair-Builder.—Is a complete work on Stair-Building and Hand-Railing. Fully explained and illustrated by large scale diagrams, in two colors, with designs for Staircases, Newels, Balusters, and Hand-Rails. Royal Quarto. Post-paid, \$6.00.

Monckton's National Carpenter and Joiner.—A complete work, covering the whole science of Carpentry, Joinery, Roofing, Framing, etc., fully explained and illustrated by large scale diagrams in two colors. Royal Quarto. Post-paid, \$6.00.



Woodward's National Architect.—1,000 Designs, Plans, and Details for Country, Suburban, and Village Houses; with Perspective Views, Front and Side Elevations, Sections, Full Detail Drawings, Specifications, and Estimates. Also, Detail Drawings to Working Scale, of Brackets, Cornices, French Roofs, Sectional and Framing Plans of French Roofs, Dormer-Windows for French Roofs, Bay-Windows, Verandas, Porches, Plaster Finish, Cornices, Ceilings, Hard-wood Mantels, and all that is required by a Builder to design, specify, erect, and finish in the most approved style. One superb quarto volume. Post-paid, \$12.00.

ORANGE JUDD COMPANY, Publishers, 245 Broadway, New York.

Woodward's Cottages and Farm Houses.—188 Designs and Plans of low-priced Cottages, Farm Houses, and Out-Buildings. Post-paid, \$1.50.

Woodward's Suburban and Country Houses.—70 Designs and Plans, and numerous examples of the French Roof. Post-paid, \$1.50.



Woodward's Country Homes.—150 Designs and Plans, with Description of the Manner of Constructing Balloon Frames. Post-paid, \$1.50.

Woodward's Graperies and Horticultural Buildings.—Designs and Plans of Hot-Beds, Cold-Pits, Propagating Houses, Forcing Houses, Hot and Cold Graperies, Green Houses, Conservatories, Orchard Houses, etc., with the various modes of Ventilating and Heating. Post-paid, \$1.50.

Wheeler's Rural Homes.—Houses suited to Country Life. Post-paid, \$2.00.

Wheeler's Homes for the People.—100 Original Designs, with full Descriptions, and Constructive and Miscellaneous Details. Post-paid, \$3.00.

Harney's Barns, Out-Buildings, and Fences.—Containing Designs and Plans of Stables, Farm Barns, Out-Buildings, Gates, Gateways, Fences, Stable Fittings and Furniture, with nearly 200 Illustrations. Royal quarto. Post-paid, \$6.00.

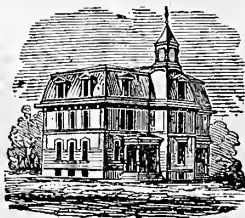

Eveleth's School-house Architecture.—A new and original work, containing Seventeen Designs for School-houses, Sixty-seven Plates with Perspectives, Elevations, Plans, Sections, Details, Specifications all drawn to working scale, with methods of Heating and Ventilation. Large quarto. Post-paid, \$6.00.

Copley's Plain and Ornamental Alphabets.—Giving examples in all styles, together with Maps, Titles, Borders, Meridians, Ciphers, Monograms, Flourishes, etc., adapted for the practical use of Surveyors, Civil Engineers, Draughtsmen, Architects, Sign Painters, Schools, etc. Post-paid, \$3.00.

HO! FOR IOWA

HOMES, at \$5 and \$6 per acre, on long time. Over 1,500,000 acres Railroad Lands, free from mortgage, for sale by the Iowa Railroad Land Co., all on the C. & N. W. & Ill. Central Railway lines, in the middle region of Western Iowa, the richest farming belt in the West. Pure water abundant. No fever and ague. Send for a land guide. It costs nothing, and gives every needful information. Address

JOHN B. CALHOUN,

Laud Commissioner,

90 Randolph Street, Chicago, or Cedar Rapids, Iowa.

FOR FRUIT, ORNAMENT.

TREES

FOR PLEASURE, PROFIT.

And PLANTS from an Old and Reliable Nursery.

**Pears, Grapes, Apples, Cherries,
Peaches, Quinces, Plums, Berries.**

COMMON AND RARE

EVERGREENS & DECIDUOUS TREES.

Variegated-Leaved and Flowering Shrubs,
Clematis Jackmanii and other Climbing Vines.

ROSES—Moss, Tea, and Perpetual.

Small, well-rooted plants of the most desirable sorts of the following sent by mail, post-paid, on receipt of price:

6 Choice Roses for.....\$1.00 | 13 Choice Roses for.....\$2.00
6 Variegated-leaved and Flowering Shrubs for.....\$1.00
13 do do do do.....\$2.00

500 Acres of } **T. C. MAXWELL & BROS.,**
Nursery. } Catalogues Free. Geneva, N. Y.

FRUIT KNOX
FRUIT FARM & NURSERIES

**FRUITS AND FLOWERS
FOR 1874.**

Send stamp for Catalogue of Vines, Plants, Trees, etc.
GRIMES & MEYER, Box 115, Pittsburgh, Pa.

B "Traver's Broom-Corn Cultivator and Broom-Makers' Manual." Price 50c. Tenn. Evergreen Broom-Corn Seed, dead ripe, \$3.50 per bush, less quantity, \$1.00 per peck.
Charleston, Coles Co., Ill. **R. A. TRAVER.** **C**

THE NEW METHOD OF TREATING RUPTURE.—It is a comparatively short time since the Elastic Truss Company introduced the new method of treating Rupture which is now so universally adopted by the well-informed portion of the community. No Ruptured person who has once seen the new Elastic Truss sold so cheap at 683 Broadway, New York, would wear any of the old-fashioned metal or "finger-pad" torturing spring trusses any sooner than he would wear copper-seated trousers with sheet-iron knees riveted down the seams. The new Elastic Truss will hold the worst cases of Rupture absolutely secure with perfect ease and freedom from inconvenience. It readily adapts itself to every motion of the body, still holding the Rupture during the hardest exercise or severest strain in horseback riding, in pitching hay, etc. If directions are followed a perfect and permanent cure will be gradually but surely effected. Full descriptive circulars, with abundant testimonials, will be sent on application to the Elastic Truss Co., No. 683 Broadway, New York City—who send this new and wonderfully effective Truss by mail if desired.

INVENTORS

Who wish to secure PATENTS should write to **MUNN & CO., 37 Park Row,** New York, for Advice and Pamphlet, 108 pages, FREE.

ADVERTISING RATES.

American Agriculturist.

ENGLISH EDITION.

Inside Pages, \$1.50 per line (agate), each insertion.
Open Pages (open without cutting), \$2 per line.
Last Page, and 2d and 3d Cover Pages—\$2.50 per line.
Page next to Reading and Last Cover Page—\$3.00 per line
No advertisement inserted for less than \$5.00.

GERMAN EDITION.

Inside Pages, 25 cents per line, each insertion.
Business Notices and Last Page, 40 cents per line.
No advertisement inserted for less than \$1.00.

Hearth and Home.

Inside Pages, per line (agate), each insertion.....50 cents.
Business Notices, 7th Page, and Last Page.....75 cents.
Reading Notices per line.....\$1 00
No Advertisement inserted for less than \$2.00.

No Advertisement of Medicines or Humbugs received.
Address all orders to

ORANGE JUDD COMPANY,
245 BROADWAY, NEW YORK.

AMERICAN AGRICULTURIST

FOR THE

Farm, Garden, and Household.

"AGRICULTURE IS THE MOST HEALTHFUL, MOST USEFUL, AND MOST NOBLE EMPLOYMENT OF MAN."—WASHINGTON.

ORANGE JUDD COMPANY,
PUBLISHERS AND PROPRIETORS.
Office, 245 BROADWAY.

ESTABLISHED IN 1842.

Published also in German at \$1.50 a Year.

{ \$1.50 PER ANNUM, IN ADVANCE
SINGLE NUMBER, 15 CENTS.
{ Copies for \$5; 10 for \$12; 20 or more, \$1 each.

Entered according to Act of Congress, in March, 1874, by the ORANGE JUDD COMPANY, at the Office of the Librarian of Congress, at Washington.

VOLUME XXXIII.—No. 4.

NEW YORK, APRIL, 1874.

NEW SERIES—No. 327.



JOHN JOHNSTON.

Contents for April, 1874.

Agriculture, French... 139
Barn Yard, Plan of a... 2 Illustrations... 136
Bee Notes for April... 129
Boys and Girls' Columns—Some "Very Wonderful Plants"—A Strange Bird—Aunt Sue's Puzzle-Box—A Corresponding Society—First Lesson in Rowing—Writing for the Paper... 5 Illustrations... 147, 148
Bulbs, Seeds, etc., Treatment of Tropical... 142
Catalogues Received... 129
Cheese Factory, How to Start a... 12 Illustrations... 137
Concrete Building... 2 Illustrations... 136
Farmers' Clubs... 140
Farm, Laying out a Western... Illustrated... 139
Flower Garden and Lawn for April... 124
Flowers, Drummond's Phlox... Illustrated... 141
Fruit Garden for April... 123
Greenhouse and Cellar, Combined... Illustrated... 141
Greenhouse and Window Plants for April... 124
Horse Power, How to Load a... 3 Illustrations... 135
Household Department—About Earth Closets—What shall we have for Breakfast?—Home Topics... 2 Illustrations... 145, 146
John Johnston... Illustrated... 130
Kitchen Garden for April... 123
Lamb, Spring Management of... Illustrated... 133
Leather, How it is Tanned... 7 Illustrations... 139
Market Report for April... 124
Milk, Varieties of... 3 Illustrations... 138
Ogden Farm Papers, No. 50—Dairy, Coloring Butter—Cooking Food for Stock... 130, 132
Orchard and Nursery for April... 123
Plants, Clematis... 142
Plants, Forced... 143
Plants, Rock Tunicia... Illustrated... 144
Plows, An Improvement in... 2 Illustrations... 132
Sheep, Oxford Down... Illustrated... 133
Shrub, A California... Illustrated... 144
Tobacco, Cultivation of... 139
Tomatoes, Experience with... 143
Trees—Planting upon Highways... 129
Walks and Talks on the Farm, No. 124—Oats and Peas—Mustard—Apple Orchard—Northern Spies—Market Report in London—Petroleum—Pigs—Corn—Oil Cake and Peas—Potato Prizes... 134, 135
Work, Hints About... 122
Yucca and Its Uses... 143

INDEX TO "BASKET," OR SHORTER ARTICLES.

Am. Tarf Register and Hay Fork, The Best... 128
Racing Calendar... 128
Arbor Day in Iowa... 126
Ashes for Peach Trees... 128
Bed-bugs... 128
Blackberry, Snyder... 126
Book Notices... 126
Book on Horses... 127
Bromophyte... 127
Buckwheat... 128
Cabbage Plants... 127
Cellar Wall, Frost Dis-tributing... 127
Chromo, Purdy's... 127
Chromos, Varnishing... 128
Chromo, Vick's... 126
Close Breeding... 126
Colt, How to Feed a... 128
Colonies, Government Help for... 127
Compost, Heat for a... 127
Congress, Watch... 125
Corn and Bran, Value of... 126
Corn, Sanford... 127
Dairy Business in the West... 128
Dairymen's Association, North-Western... 127
Dish-Cloth, Iron... 128
Dog Power... 127
Eleagnus parvifolius... 127
Exhibition in Chili... 126
Fields, Impr'g Southern... 128
Gardeners' Monthly... 127
Hay Fork, The Best... 128
Hoof, Contraction in... 127
Humbugs, Horticultural... 128
Humbugs, Sundry... 125
Lands, Neb. and Minn... 126
Landscape Gardener... 126
Lucern... 126
Mill, Howard... 127
Name, Your... 127
Night Soil, Utilizing... 128
Oats, How many Bundles to an Acre... 127
Oils, Safe... 127
Paint, Averill Chemical... 125
Patented Articles... 127
Patrons of Husbandry... 125
Peristrophe... 126
Petroleum for Priming... 129
Play and Profit in my Garden... 126
Posts, Preserving... 127
Poultry Book... 127
Prairie, Breaking... 127
Primula Japonica... 128
Replies, Delay in... 127
Roofing, Asbestos... 126
Roses, Insects on... 128
Strawberries... 128
Soap and Glue Refuse... 128
Tallow Scraps... 127
Transactions of Maes, Hort. Society... 126
Wheat, Harrowing... 128
Wheat, Plaster upon... 127

Oranges from Seed.—Some time ago we stated, in reply to a correspondent, that oranges from the seed would not be precisely like the parent fruit from which the seed was taken. Several correspondents in Florida wrote that this was a mistake, and that the fruit was reproduced with exactness. We now find our position sustained by the Florida Agriculturist. While seeds from the sweet orange will produce trees bearing sweet fruit, they will differ in other qualities, including productiveness, and the only sure way of perpetuating a variety and preserving every one of its qualities and peculiarities unchanged is by budding or grafting.

Bogardus Bone-Mill.—"Englishman," Lynchburg, Va. The Bogardus bone-mill, to which we have before referred as the best bone-mill, may be procured of A. Bogardus & Co., Center street, New York.

Calendar for April.

Table with columns for Day of Month, Day of Week, and sunrise/sunset times for Boston, N. York, Philadelphia, and Washington.

PHASES OF THE MOON.

Table showing moon phases (Full, 3d, New, 1st) and times for Boston, N. York, Wash'n, Cha'ston, and Chicago.

AMERICAN AGRICULTURIST.

NEW YORK, APRIL, 1874.

We have had a remarkably mild winter, and the indications now are that we shall have an early spring. Winter wheat, on our own farm, and we believe it is so generally, never looked better. It is, of course, still liable to many drawbacks, but on the whole there is a good prospect of an abundant wheat harvest. We hope such will prove to be the case. The country needs a big wheat crop and liberal prices. We hope for both the present year. There is a cheerful prospect for all good farmers. We have had gloomy times. It has required strong faith to keep on improving the land, paying high wages, and getting low prices. But those who have now got their land dry, clean, and rich are in a condition to reap the reward of their faith and practice. This is the great lesson taught by all agricultural history and experience. Do the work as cheaply and economically as possible, but do it, and do it thoroughly. Slipshod farming; resorting to temporary expedients; checking weeds, instead of killing them; sowing when there is no reasonable prospect of getting a good crop, and doing this year after year is about the meanest business an intelligent man can engage in. Farming is a pleasant, profitable, honorable, and eminently useful occupation—but it must be good farming. Poor farming, with no efforts to improve the land and the stock is forlorn drudgery.

Farming is essentially slow. The husbandman waiteth patiently. He must look ahead. He lays plans and does work for the future. And the better he plans and the more he works and the farther he looks ahead, the more pleasure will he have day by day and the greater will be his ultimate profit.

Hints about Work.

Happy is the farmer who has got everything ready for the active labors of the coming season. But no matter how thoroughly he is prepared there will always be a plenty to do.

Work makes work.—Something will break and has to be mended. Something will be lost and has to be found. Tools are scattered here and there and must be put in their places.

System and Order are absolutely essential to success in farming. But work is no less essential.

Whatever accomplishes the most work at the least cost is the best system.

"Come Boys," must be the motto of the farmer who employs much labor. He must be with his men. But unless he is a remarkably vigorous and healthy man he ought not to try to do as much work as his men and superintend his farm besides. Work occasionally, and put new vigor into the men. Show them how to do the work to the best advantage. Plan, direct, be quick to see the weak spot and prompt to lend a helping hand.

Steady Work like plowing will almost do itself. It is the odd jobs that require brains. You must do the thinking.

A good Boy will often do as much work as a man. But you must know how to treat him in order to make him useful. Give him the best tools, the best plow, the steadiest team and the newest harness. If he breaks anything do not scold, but help him to repair damages and encourage him to do better. Above all do not let the men impose on him. If you breakfast early, a growing boy that is at work in the field should have a lunch at half-past nine or ten o'clock. No one can work long without eating, especially a growing boy.

Rainy Days are usually numerous this month. But you will find work enough that needs doing in the cellar or in the sheds or barns.

A Cheap Memorandum Book in which you can note down work to be done, is of great advantage—provided you use it.

Work to be done may be classified under three heads. First, Work for rainy days; Second, Work for fair days when the ground is too wet to plow; Third, Regular farm work when the weather and land are both dry.

Under Rainy Days would come such work as repairs, oiling harness, sorting potatoes, and cutting them for seed; mixing ashes, plaster, and hen droppings; whitewashing; cleaning and oiling implements and machines with petroleum, both wood-work and iron; grinding spades, hoes, axes, etc.; cutting up hay, and a dozen other things that will readily occur.

Under When the Ground is Wet comes underdraining; cleaning out ditches, letting off surface water; repairing fences and gates; piling, turning, or spreading manure; washing fruit-trees with lye or carbolic soap; scraping up the mud and scattered manure in the barn-yard; blasting large stones, etc., etc. The morning after the next heavy rain, fill up the list yourself. You will find it very useful.

Under Regular Work include the general field work of the farm, such as plowing, harrowing, cultivating, rolling, drilling, picking off stones, hauling manure, etc., etc. Go into details. Make estimates of how long the work will take, and see that you have everything ready for emergencies.

Sowing Clover on winter wheat is usually done before the frost is fairly out of the ground. If delayed till the land is dry, harrow the wheat with a light harrow before sowing the clover and then harrow or roll afterwards. Six quarts of clover and four of timothy per acre is none too much seed. If possible select a still day for sowing. See that there is no space left unsown.

Get Crops in Early, but not before the land is in good working condition.

Spring Wheat is usually the first crop sown.

Barley can not be sown too early, provided the land is in the proper condition. It should be made as fine and mellow as possible. Sow from 1 1/2 to 2 1/2 bushels per acre. Barley and spring wheat are both good crops with which to sow clover and grass seed. Make the land as fine as possible by repeated harrowings before sowing, and then roll after the grass seed is sown.

Oats or Peas do better on a recently inverted sod than barley. But if the sod is old and tough it is better to plant it to corn.

Potatoes require dry land. A rich, clover sod is excellent. But if the land is rich enough potatoes can be successfully grown after any crop. If

manure is used it should be well rotted and fine, and the more thoroughly it is mixed and incorporated with the soil, the less likely it is to injure the quality of the potatoes. Peruvian guano is one of the best auxiliary manures for potatoes—say 200 pounds per acre sown broadcast, or a tablespoonful dropped in the hill and mixed with the soil before dropping the potatoes. The latter is the better way to apply it, provided the work is done carefully. Peruvian guano, if a good article, will burn the potatoes if they come in direct contact with it.

On Sod Land it is far more convenient to plant potatoes in hills, three feet apart, than in drills. On mellow, rich land, where furrows can be opened with a plow, it is a good plan to make the furrows 3 feet apart and drop the sets in the furrow every 15 or 18 inches and cover with the plow. If the land is rich enough a larger crop can be obtained in this way than by planting in hills.

Harrowing the Potatoes with a light harrow, just as soon as they begin to break the ground, will kill millions of young weeds and favor the growth of the potatoes. On our own farm we use a Thomas harrow for this purpose, and go over the ground three or four times. We have frequently used an ordinary harrow. It pulls up a few hills, but not enough to do serious damage to the crop.

Mangel Wurzel is a favorite crop with us. It requires rich land. Should be sown early in drills, 2½ feet apart, and thinned out in the rows, 12 to 15 inches apart. If drilled in, 4 lbs. seed per acre; if dibbled in, 15 inches apart, 2 lbs. is sufficient. In the latter case soak the seed for 48 hours.

Animals require special care at this season. The weather is very changeable and horses and cows are shedding their coats and liable to catch cold.

Sheep must be managed according to circumstances. If the yards are large and dry and you have plenty of roots it is probably best to keep them out of the pastures until there is a good bite of grass. If the yards are small and muddy it will be well to let them run out every fine day. A sod field that is to be plowed for corn will make a good run for them and will save the regular pasture. Feed all the hay they will eat. It is a great mistake to stop feeding hay and grain as soon as the sheep are turned to pasture. They may not eat much hay, but they should have access to it and be allowed to eat at will.

Ewes and Lambs need warm, dry, sunny quarters. Feed the ewes a plenty of bran, early cut clover or other hay and as many roots as can be spared. Unless the ewes are very fat, a pound of oats each per day may be fed with great advantage. Be careful to avoid exposing the sheep and lambs to rain storms. If a lamb gets chilled, wrap it in a warm blanket; or, in extreme cases, put the lamb in a tub of warm water. Lambs apparently dead have been restored in this way.

Horses.—Feed liberally and allow plenty of time to rest and digest their food. It is better to work them steadily for eight or nine hours than to keep them in the field ten or twelve hours, letting them stand still one third of the time. When a man needs to go home to lunch or supper the horses need food also. A pail of water with a pint of corn or oat meal stirred in it is a capital thing for a tired horse. It will enable him to work an hour or two longer in an emergency.

Cows should be carded every day. See Hints for last month in regard to calving. It is especially important to feed new milch cows liberally and with good judgment at this season. Do not be in a hurry to turn them out to grass. Give plenty of early cut hay and have enough to keep their bowels moderately loose. If thin, give a little corn-meal or oilcake meal in addition. Cut the hay, moisten it with water, and mix about two quarts of bran and a quart of corn-meal with a bushel of the chaffed hay and let the cows have all they will eat up clean. When turned out into the yard, let them have a little long hay in the racks to pick at. A cow giving milk needs a great deal of water. Let her have access to it all day, or at any rate

night and morning. If you can give each cow half a bushel of mangels, or beets, or parsnips, or carrots daily it will be of advantage.

Swine.—It now looks as if pork would next fall and winter bring higher figures than for the last two or three years. Many farmers in the West say it does not pay to feed out "fifty-cent corn." We think they are wrong. At any rate one thing is certain, if pigs are kept at all it will pay to keep them in good growing condition.

Last Fall Pigs should be fed very liberally at this season, in order that when they are turned out to grass or clover they may be strong and vigorous. If they are fat now they will keep fat all summer on good clover. With us this is the cheapest way to make pork.

A Sow should be placed in a warm, comfortable pen some days before she is expected to farrow. The object is to let her get accustomed to the new pen. It is well to let her out every day for exercise before she pigs and occasionally afterwards. Give a little flax-seed tea or oil-meal slops and bran to keep the bowels open.

After Farrowing give her for a few days thin, warm bran slops three times a day. Gradually give richer food, such as oat, corn or pea meal, mixed with bran and mixed with slops from the house or with milk. If cooked and fed warm it will favor the production of milk. With well-bred sows the milk is often too rich, and we should aim to feed in such a way as to increase its quantity, but not its quality. Perhaps there is nothing better for this purpose than brewers' grains, or warm whey, or skim-milk and scalded bran.

Work in the Horticultural Departments.

The warm, sunny days of April will be the signal for the commencement of active out-door operations. To him who has completed everything which could be done to advance the spring work, the coming labors will be comparatively easy; but if these have been neglected there is great danger of falling behind with work. Gardening, to reach the greatest success, requires as much forethought as any mercantile business, and he who has the clearest head, combined with energy and skill, will be the most successful. Hurry up all the little jobs which can be done now, and then when the ground becomes warm and dry no delay need occur in plowing and putting in the various crops. Provide some in-door work for the men for rainy days; these will happen often during the season, and the men feel better when there is something to occupy their attention than if idle. Nothing is better for this purpose than a tool-house supplied with a good set of carpenter's tools and other necessary implements in constant use in and around the garden and buildings. Provide duplicate handles for the forks, hoes, etc., so that if any accident should occur they can easily be repaired. See that all broken tools are mended or new ones put in their places. Nothing so discourages a workman as a broken or poor tool. Teams which have been idle during the winter must be put to hard work gradually; otherwise they are liable to give out.

Orchard and Nursery.

Cions.—If not yet cut, attend to it at once, as it will not do to cut after the buds have started. Preserve in sand or sawdust until needed.

Root Grafts.—Plant in nursery rows as soon as the ground will allow.

Seeds of fruit and ornamental trees should be sown as soon as the ground is in good condition. Peach-stones, nuts, etc., which were buried in boxes in the open ground last fall should be planted at once before they commence to grow.

Grafting.—Do not commence until the buds swell. If left until too late the bark slips so readily that there is danger of injuring the tree by peeling.

Tree Planting.—In planting, do not attempt to do it hastily; one tree planted well is worth a dozen poorly set. Take pains to break all lumps which

come in contact with the roots, and, besides, make the hole large enough to allow the roots to lie straight in their natural positions.

Insects will still need looking after, as eternal vigilance is the price of healthy trees and good fruit. Wash the trunks and larger limbs with lye or soft soapsuds if not already done; this, if done with a stiff brush after the old bark has been scraped off, will destroy most of the eggs of insects. Look out for the rings of tent-caterpillars' eggs on the ends of the twigs; they can be easily seen and destroyed now.

Fruit Garden.

Currants.—Every garden should have an abundant supply of currant bushes, as with proper care they may be made to yield large crops of fruit, both for market and home use. Plant cuttings in rows two feet apart, and the plants six inches in the rows. In two or three years they will make bearing plants. Versailles and White Grape are the best varieties for general cultivation.

Strawberries need to be set out as early as the ground can be worked. Give the newly-planted beds, as well as the bearing ones, a good mulch of cut hay or straw, or even leaves. Set the plants in hills 18 inches apart, with the rows two feet. Do not allow the newly-planted beds to bear before the second year, as the plants will then be stronger and better able to bear good crops afterwards.

Raspberries and Blackberries must be set out early this month if the ground is dry. Four feet each way for raspberries and 6 x 8 feet for blackberries.

Grapes.—Set out vines one year old in well-drained soil which has been enriched by ashes or ground bone. Do not use heating manures, as they cause a very rapid growth, which is so prolonged that the wood does not have time to ripen properly before cold weather commences; hence the wood is readily injured by frosts. Select a proper proportion of early, medium, and late sorts, so that there will be a constant succession of fruit throughout the season. Cuttings preserved in the cellar since last fall should now be planted out in rows 18 inches apart, setting the cuttings four inches apart in the rows, and pressing the earth very firmly down around the bases of the cuttings.

Gooseberries.—Set out Houghton and other American varieties. Give thorough cultivation and plenty of manure.

Quinces.—A handsome pyramidal quince-bush can be secured if properly trained and pruned; as usually seen, they are not ornamental objects.

Figs can not be grown profitably north of the latitude of Maryland, but a few trees are easily taken up and stored in the cellar in the fall, and when planted among other fruit trees they give a pleasing variety.

Kitchen Garden.

For directions for making hot-beds last month's hints may be consulted, and also for many other operations which will be in season for the present month. Hot-beds must be carefully watched lest the heat become strong enough to burn the young seedlings. Remove the sash when the weather will allow; when too cool to remove admit air by raising the sash a few inches at the back.

Asparagus.—Remove the coarse litter from the beds and fork in the manure as soon as the ground is dry. Apply a coat of salt to established beds.

Beans.—In the Northern States the latter part of the present month is early enough for planting; however, it will be worth a trial to plant a few rows now, and if there is any danger of frosts protect the young plants by placing two boards edgewise, like an inverted trough, along the rows so that they will form a shelter for them.

Beets.—Sow as early as the state of the ground will allow, as they will stand considerable frost.

Cabbages and Cauliflowers.—Set out plants from the hot-bed and cold-frame in rows 18 x 24 inches, and plant lettuces between; the latter will be out

of the way before the room is needed for the eabages. Sow seeds in open ground.

Carrots.—Sow a few rows for early use in warm, rich soil in drills a foot apart; put in plenty of seed to insure a good start.

Celery.—Set out plants for early crop. Sow seeds in drills eight inches apart.

Chives.—As soon as the soil is dry fork in a dressing of fine manure around the plants and remove all the old leaves. New beds may be made by division of the plants.

Cucumbers.—Sow a few seeds in pots or bits of sod in a hot-bed, so that they can be readily removed as soon as the weather is warm enough. Do not plant in open ground until next month.

Egg-Plants.—Sow in hot-bed giving considerable heat, and take care not to check growth untimely by removing the sashes.

Garlic.—Set bulbs in rows 12 inches apart, allowing six inches between the plants.

Horseradish.—Plant out sets in rows, in well-manured soil, 24 x 15 inches.

Herbs.—A supply of the more common herbs should be sown. Sage, thyme, summer savory, etc., are in general use for flavoring. Sow in a warm place or frame in rows four inches apart.

Leeks.—Sow seed as early as possible in fine soil in fifteen-inch rows.

Lettuce.—Set out plants from the cold-frame in rows a foot apart, and the plants six inches in the rows. There are many vacant spots where a few plants may be set.

Onions.—The sooner the seed is put in after the ground is open the better is the prospect for a crop. In sowing, radish seed is sometimes mixed with it, which allows the rows to be seen readily and the weeds sooner hoed up between the rows. Plant in rows 15 inches apart. Top and potato onions should be set at once in rich soil.

Parsley.—Sow in hot-bed or open ground, first soaking the seed in hot water a short time.

Parsnips.—Sow at once in very rich deep soil, so that they may get a good start before very warm weather. Sow in rows 15 inches apart.

Peas will bear considerable frost, and the sooner they are planted the better they will yield. Do not plant the dwarfs until the ground is warm and dry.

Peppers require to be treated the same as recommended for egg-plants.

Potatoes that have been cut and started in the hot-bed may be set out at once in rows two to three feet apart, and one foot in the rows. Plant all garden sorts early.

Radishes.—Sow a few rows every week or ten days during this month. Sow thickly in rows one foot apart.

Salsify and Scorzonera.—These two vegetables ought not to be neglected, for if once raised we think they will always form a part of the gardener's crops. Their culture is the same as for carrots.

Spinach.—Keep down the weeds in the beds sown last fall, and sow seed in rows a foot apart.

Seeds.—Persons raising their own seeds should set out the most perfect specimens of beets, parsnips, etc., early.

Tomatoes.—It is yet too early to trust plants in the open ground. The earliest should be transplanted to pots or boxes, where they will have more room to grow, and so that they can be readily removed without injuring the roots.

Turnips.—Sow a few rows for early use, and as soon as they are up sprinkle with plaster to preserve from insects.

Flower Garden and Lawn.

There will be plenty of work in this department on the opening of spring weather. Rubbish, broken limbs, and everything which can disfigure the appearance of the garden and its surroundings should be cleared away.

Lawn.—Apply a dressing of bone, ashes, or other

fertilizer. If any patches are thin or bare sow seed thickly after loosening the soil with a rake.

Bulbs which were planted last fall should have the covering of hay or leaves taken off, and the ground loosened around the plants, which will just now show themselves above the ground.

Ornamental Trees.—Set out such varieties as are needed for shade or ornament. Evergreens do best if not moved until May.

Annuals.—Sow seeds of the hardy kinds.

Herbaceous Perennials.—Move and divide at once if not yet attended to, as many of the sorts will commence flowering soon. A light, loamy, well drained soil is the best for most sorts.

Biennials.—Transplant such plants as Hollyhocks, Sweet Williams, etc., from the beds to where they are to flower; the earlier this is done the better.

Climbers.—Provide plenty of climbers for ornamenting and covering porches, arbors, and rustic-work. Clematis, Trumpet-creeper, Honey-suckle, Wistarias, Akebia, and the like are very ornamental both in flower and foliage, and many an otherwise bare-looking spot can be easily covered by these hardy climbers.

Hedges.—Trim and stir the soil around the plants as early as possible, and if any new hedges are wanted order the plants at once.

Wind-breaks are very useful, as well as necessary in a flat country, and trees to serve this purpose should be planted wherever needed. Norway Spruce is one of the best evergreens for this purpose, as it is of rapid growth.

Drives and Walks should be laid out and made at once, for if left until later there will be too much work on hand to do it properly.

Greenhouse and Window Plants.

Ventilation is the main point to look after now. Admit air every warm day, so that those plants which are to be set out in the open border may be properly hardened off.

Propagation of the desirable sorts may still be continued, and the plants, as soon as rooted, potted and placed in shade until established.

Seeds.—Sow seeds of annuals in greenhouse or window boxes. Balsams, Asters, etc., do better if started in this way.

Insects.—Keep the greenhouse clear of insects by smoking, washing, etc. The red spider may be destroyed by keeping the house damp.

Camellias which are growing should have plenty of water and a little more heat.

Azaleas.—Prune and bring into shape by judicious tying as soon as the plants have done flowering.

Bulbs that have completed their growth of leaves may be turned out of the pots and stored in a dry, cool place. Ixias and other greenhouse bulbs should have plenty of water while flowering.

Tuberose.—Start bulbs in the greenhouse for planting outside.

Cannas and other tropical tuberous-rooted plants do better if started in a little heat and planted out-of-doors from the first until the last of May, according to locality.

Plants wintered over in the cellar will need looking after, and water given occasionally as needed.

Commercial Matters—Market Prices.

The following condensed, comprehensive tables, carefully prepared specially for the American Agriculturist, from our daily record during the year, show at a glance the transactions for the month ending March 13th, 1874, and for the corresponding month last year:

Table with 2 columns: RECEIPTS and SALES. Rows include Flour, Wheat, Corn, Rye, Barley, Oats, and various other agricultural products with prices for 1874 and 1873.

Table 2: Comparison with same period at this time last year. Rows include Receipts for Flour, Wheat, Corn, Rye, Barley, Oats for 24 and 23 days in 1874 and 1873.

Table 3: Stock of grain in store at New York. Rows include Wheat, Corn, Rye, Barley, Oats, and Malt for various dates in 1874 and 1873.

Table 4: Exports from New York, Jan. 1 to March 12. Rows include Flour, Wheat, Corn, Rye, Barley, Oats, and Peas for 1874 and 1873.

Gold has been up to 113 and down to 111 1/2—closing March 12th at 112 as against 112 1/2 on February 12th. All things considered, a remarkably active movement for the season has been noted in the leading kinds of Produce, the receipts and sales of Breadstuffs having been in excess of those of the same time last year. The business in Flour, Wheat, Corn, and Rye has been in good part for shipment. Under the liberal arrivals prices generally yielded, but closed with more steadiness. The scant supply of freight room available for prompt use has been against the export trade. The dealings in Barley have been less extensive, and at lower figures. The offerings of foreign have been large and urgent, partly to arrive. Oats have met with a ready sale, mostly for local trade purposes, and have held their own well as to values. The inquiry for the principal kinds of Provisions has been fairly active, but at variable prices, closing more firmly. Butter and Cheese dearer, and in good request. Eggs closed lower, with a very moderate demand from consumers. Cotton has been quite freely purchased, but closed in favor of buyers. Wool has been less sought after and rather less firm. The better grades of domestic have been in quite moderate supply. Manufacturers have been operating reservedly. Tobacco, Seeds, Hay, and Straw have attracted less attention. The offerings of Hay and Straw toward the close were on a liberal scale. Hops have been very dull, and generally weak; though strictly prime to choice stock was held with a fair share of confidence, having been comparatively scarce.

CURRENT WHOLESALE PRICES.

Table with columns for Feb. 13 and March 13. Rows include Price of Gold, Flour, Wheat, Corn, Rye, Barley, Oats, and various other commodities with prices for both dates.

New York Live-Stock Markets.

RECEIPTS.					
WEEK ENDING	Beesves.	Cows.	Calfes.	Sheep.	Swine. Tot'l.
February 16.....	7,481	48	609	19,446	36,330
February 23.....	6,405	52	684	25,423	23,050
March 2.....	6,709	40	573	14,264	22,945
March 9.....	6,956	78	703	19,631	28,218
March 16.....	7,022	56	642	20,002	32,550
Total for 5 Weeks.....	31,573	274	3,111	98,766	143,093
do. for prev. 4 Weeks.....	32,954	189	2,426	96,322	127,388
Average per Week.....					
do. do. last Month.....	6,315	55	622	19,753	24,619
do. do. prev's Month.....	8,238	47	606	24,080	31,822
do. do. prev's Month.....	7,042	62	617	20,219	34,388

Beesves.—The month's business has been characterized by dullness and depression, although prices have not given way. The reduced receipts, however, finally told upon the market, and with the disappearance of stale stocks of dressed meat a general improvement occurred. This was apparent in the tone of the market rather than in prices, as may be seen by the latest quotations, which show no actual advance. On the whole, however, less quality was given for the same money at the close than at any previous time during the month. Texans sold at 9 1/4 c. @ 10 c. 3/4 lb. to dress 56 lbs.; native steers at 10 c. @ 12 1/4 c. to dress 56 @ 58 lbs.; extra and fancy brought 12 1/2 c. @ 13 c. to dress 58 @ 60 lbs. A year ago the choicest steers brought 13 1/2 c. @ 14 1/2 c. 3/4 lb., although the average of the market was but 1/2 c. 3/4 lb. above our present quotations.

Prices for the past five weeks were:

WEEK ENDING	Range.	Large Sales.	Aver.
February 16.....	7 @ 13 c.	10 @ 10 1/2 c.	10 1/2 c.
February 23.....	8 1/2 @ 13 c.	10 1/2 @ 10 1/2 c.	10 1/2 c.
March 2.....	8 1/2 @ 13 c.	10 @ 11 c.	10 1/2 c.
March 9.....	8 1/2 @ 13 c.	10 1/2 @ 11 c.	10 1/2 c.
March 16.....	8 1/2 @ 13 c.	10 1/2 @ 11 c.	10 1/2 c.

Milk Cows.—For cows the market has been quiet but steady; all have been readily sold that were offered at \$40 @ \$30 for cow and calf. . . . **Calves.**—There has been a steady demand for hog-dressed veals, and at the close an easy market prevailed at 11 c. @ 13 1/2 c. 3/4 lb. for fair to good. Milk-fed gradually weakened, closing at 6 1/2 c. @ 7 1/2 c. 3/4 lb. Good to choice grass calves closed at \$12 @ \$15 3/4 head. . . . **Sheep.**—After a dull market for the month, with falling prices, an improvement could be noticed at the close. The feeling was firmer, but buyers resisted effectually the advances of sellers, and sales were made at 5 1/2 c. 3/4 lb. for common, up to 8 c. @ 8 1/2 c. 3/4 lb. for extra lots. . . . **Swine.**—Live hogs have been neglected, and the market is reported as closing dull at the reduced rates of 5 1/2 c. 3/4 lb. for common to good, and 6 c. 3/4 lb. for the best. Dressed hogs closed in fair demand at 6 1/2 c. @ 7 c. 3/4 lb., and for Western at 7 c.



containing a great variety of items, including many good hints and suggestions which we throw into smaller type and condensed form, for want of space elsewhere.

Remitting Money: — Checks on New York City Banks or Bankers are best for large sums; make payable to the order of **Orange Judd Company.** Post-Office Money Orders for \$50 or less, are cheap and safe also. When these are not obtainable, register letters, affixing stamps for postage and registry; put in the money and seal the letter in the presence of the postmaster, and take his receipt for it. Money sent in the above three methods is safe against loss.

Postage: On *American Agriculturist*, 12 cents a year, and on *Hearth and Home*, 20 cents a year, in advance. Double rates if not paid in advance at the office where the papers are received. For subscribers in British America, the postage, as above, must be sent to this office, with the subscription, for prepayment here. Also 20 cents for delivery of *Hearth and Home* and 12 cents for delivery of *American Agriculturist* in New York City.

Bound Copies of Volume Thirty-two are now ready. Price, \$2, at our office; or \$2.50 each, if sent by mail. Any of the last seventeen volumes (16 to 32) will also be forwarded at same price. Sets of numbers sent to our office will be neatly bound in our regular style, at 75 cents per vol. (50 cents extra, if returned by mail.) Missing numbers supplied at 12 cents each.

Clubs can at any time be increased by remitting for each addition the price paid by the original members; or a small club may be increased to a larger one; thus, a person having sent 10 subscribers and \$12 may afterward send 10 more subscribers with only \$3; making a club of 20 at \$1 each; and so of the other club rates.

**REMEMBER THAT
Three Months
REMAIN
For Premiums.**

April, May, and June are the three months remaining, during which any person who wishes to obtain one or more of the useful and valuable articles offered in our Premium List (of which a copy will be sent free to any applicant, see page 159) can easily get them. This has already been done by more than 14,000 persons, who during years past have tried with success the raising of Clubs of Subscribers for our papers, and availed themselves of the liberal offers of Premiums made by the Publishers.

We invite all our Subscribers to take hold of this work and secure a Premium while the offer is open. Specimen copies of both papers will be sent to any wishing to show them for this purpose.

Our Western Office.—Our friends in the West are reminded that we have an office at No. 4 Lakeside Building, Chicago, Ill., in charge of Mr. W. H. Busbey. Subscriptions to *American Agriculturist* and *HEARTH AND HOME* are taken there, and sample copies of the papers and chromos are delivered, and orders received for advertising on the same terms as in New York. All our books are on sale at the Western Office. Please call and examine, buy, subscribe, and advertise.

Good Books.—We call the attention of all our readers to the list of books for the farm, garden, and household, which will be found on the third cover-page of this paper. No better investment can be made than that which supplies the home with interesting and instructive reading matter.

New Books.—The Orange Judd Company have just issued, in attractive duodecimo form, John Estlin Cooke's story, "Pretty Mrs. Gaston," illustrated by Bush; price, post-paid, \$1.50. Also "John Andross," by Rebecca Harding Davis; price, post-paid, \$1.50; finely illustrated by Fredericks.

P. T. Quinn's Horticultural Works.—By a natural gravitation the few rural books not originally published by the Orange Judd Company, one by one fall into their list. The latest accessions are "Pear Culture for Profit," and "Money in the Garden," by P. T. Quinn. We have already favorably noticed these works, and have only space to say that new issues of both volumes are now ready.

A New Fertilizer.—R. H. Allen & Co., N. Y., offer a new fertilizer, the nitrogen (or ammonia) in which is derived from dried blood, the richest available source. The reputation of this house is sufficient to warrant that this fertilizer is what it is represented to be. Besides this they guarantee the amounts of potash, ammonia, and soluble phosphoric acid. This is deserving of the attention of those about to purchase fertilizers.

The Patrons of Husbandry.—The interest in this order in no wise diminishes. Indeed, the late meeting of the National Grange and its eminently clear presentation of the objects of the patrons would naturally direct attention to it anew, and lead those who before regarded it with indifference to now look upon it with interest. The disclaiming of political purposes has disappointed some who hoped to turn the order to account, and perhaps led to the establishment of the "Order of Independent Grangers," who make it one of their avowed objects to take political action. In reply to those who ask for sources of information in regard to the Patrons, we would say that O. H. Kelley, Georgetown, D. C., is the Secretary of the National Grange, and we assume, without knowing it to be the case, that he can supply circulars, etc., to those who wish to know more definitely about the order.

Watch Congress!—No law ever passed by Congress is more directly of benefit to the agricultural community than that allowing plants, seeds, and books to be sent by mail at reduced rates of postage. This law, which places settlers in new countries and all who live at a distance from commercial centers upon an equality with those who live near them, has been a

great help to the farming community. A proposition has recently been made in Congress to exclude from the mails everything but letters and papers; and while other countries are enlarging their mail facilities, it is proposed that America shall progress backward in this matter, and prevent the farmer from receiving his seeds and books at a low rate of postage. This proposition came up about the time the attempt was made to revive the franking privilege. We advise farmers and all interested in this subject to watch Congress; and this is a case in which it becomes the Patrons of Husbandry to be vigilant. Let your representatives know that whoever votes to exclude plants, books, and seeds from the mails is thereafter politically dead. Congressmen do not seem to be aware that farmers propose to have something to say hereafter in politics. Watch the men, and see not only how they speak but how they vote.

The Averill Chemical Paint.—Several years ago we had a new barn and two outbuildings to paint, and as at that time the Averill Chemical Paint was a comparatively new thing, we determined to try it. After we had purchased the paint we found the painters of the neighborhood much prejudiced against it, and they, by predicting all sorts of evil, endeavored to deter us from using it. At last we found a man who would apply it and not talk about it. The barn had one and the other buildings two coats. The paint was applied between four and five years ago, and is still in good condition. We have no occasion to regret having used it, nor any hesitation in recommending it to others. The paint is furnished in various tasteful shades of color, and what is a great advantage is ready for immediate application. As it requires no mixing, it is especially adapted to the use of those who live in the country and wish to do their own painting.

SUNDRY HUMBUGS.—Such a pile of letters and documents and such a tame lot does not often come before us. It is very easy to write us in regard to this or that man and request us to

SHOW HIM UP.

Our friends must not be surprised if such letters are unheeded. We take as much—even more—care to avoid accusing any one unjustly as we do to show up those who deserve that distinction. We must have evidence that places the matter beyond all reasonable doubt, before we place any one in this column. Often we feel quite sure that a scheme is a swindle, but refrain from publishing it for want of evidence that would convince a jury of twelve men, should it be brought before them. Our humbug correspondence has its amusing features, but it has also a pathetic aspect. It is indeed sad to read the complaints of some of the victims, and one loses his indignation that the writers should be such fools as to be caught with a badly baited hook, and feels only pity for those who mourn over money they could ill afford to lose. Some give their unhappy experience with the Union Furnishing Co., of Chicago, and ask that it be exposed. This was done weeks ago, and recent Chicago papers say that the place is closed.

THE KENTUCKY LIBRARY LOTTERY,

they call it "gift concert," as it sounds less offensive—even publish a paper in the interest of the scheme. This sheet informs us that the 4th "grand concert" will take place on March 31st. These lotteries will probably continue as long as fools have money to throw away in the purchase of its tickets. In order to clothe the affair with an air of respectability an ex-governor is put in as manager. But all the governors past, present, and to come, will never make this other than a disgrace to the state.

THE MAGNOLIA, IOWA, LIBRARY CONCERT

is a precious specimen of a swindle, and Maynard & Co., of Magnolia, are about as sweet a set of scoundrels as ever tried to cheat a man out of \$10. These fellows send a "special notice," of which we give an extract from one of quite a file before us:

"At the grand award of gifts, Jan. 20th, we are pleased to inform you that your ticket, No. 142068, was awarded one of the miscellaneous gifts, valued at \$200. You will see by referring to circular sent to you, that on all miscellaneous gifts 5 per cent. on the valuation of each miscellaneous gift is required before the delivery of the gift, and 10 per cent. is to be deducted from each cash gift. Therefore 5 per cent. on your gift amounts to \$10, which must be sent to us, together with the ticket, within 15 days from the day you receive this notice, or the gift will be forfeited.

"Therefore if you desire the gift to be sent, remit \$10 at once." Here comes an important caution: "In sending money inclose the bills in your letter, carefully folded, seal closely, write our name, town and state plainly, and send the letter by regular mail and it will come safe, or if you desire you can register your letter, or you can send us drafts on New York or Chicago, but you must not send postal money orders, as none but distributing offices have sufficient funds on hand to pay, and it might be two months before we could get the money, when would prevent our filling your order that length of time, so be particular to send bills in letter or drafts on New York or Chicago.

"In case your ticket has been mislaid or lost, the facts must be stated and the gift will be sent and the number cancelled of record on receipt of money."

This Maynard & Co. know enough of the bad side of human nature to feel quite sure there are others in the world as big rascals as they are, and that now and then there will be found one who will take the bait and pretend that he had a ticket and lost it. Later letters show that likely the people of Magnolia have made the place too hot for them, as they contain a notice as follows:

"Since printing our notifications we have discontinued our office at Magnolia, owing to the inconvenience of its mail facilities, and hereafter in no case must any money or communication be sent to us at that office.

"Owing to the strong desire on the part of our people and the legislature to discontinue this line of business, we have decided to lend our aid in the cause of moral reform, and consequently will conduct no more distributions, and in closing up our business we simply follow our line of duty to our patrons on promises made in the past, and with many kind wishes, we are,

"Very truly yours,
MAYNARD & Co."

Then follows the address of their "financial agents" in Chicago. "Moral reform," indeed! and they propose to close up their business by getting as many times \$10 as there are fools who will send it.

There are Prize Associations in New York which do "business" on the same principle. They kindly send a ticket that has already drawn a prize, and the recipient can, by paying \$1 for the ticket and \$6.50 for "express charges and packing," have a "rosewood melodeon, valued at \$90." While on this lottery business we may add that no one need write to ask us to find out if this or that lottery has been drawn, or to see if it is true that such a ticket has drawn a prize. We can not be accessory to any such transactions. Some

WALL STREET "BROKERS"

seem to have been sending out circulars quite freely all over the country, and letters come asking if it would be safe to put money in the hands of these parties for investment. Safe! yes, indeed! The money would be so safe that the one who invests would never see it again. We advise our friends in Illinois and elsewhere to keep just as far from such "brokers" as possible. . . . If any one wishes to get cheated on a cheap sewing machine they need not send to Montreal for the purpose. They can get accommodated in Greenwlich street. . . . Victim—it should have been victim—sent \$5 for a Parisian watch and chain, and actually expected to get one. What is stranger still he sends his documents, including that lithographed letter acknowledging the money and promising to send in six weeks, to us and asks us to collect his \$5 for him. No, no, Mr. V. We have done our duty by these Paris and Geneva watch folks long ago, but you did not believe us, and wanted to "know how it is yourself." That \$5 is a first-class investment if it only keeps you from like follies hereafter. . . . The "8 pounds of butter from a gallon of milk" man is around yet. At last accounts he victimized them at Barnesville, O. . . . One Mitcham fairly shrieks in his circular for people to send him \$1 for his book that tells "how to make from \$5 to \$20 a day without capital." No, it is not likely that Mitcham gets \$20 a day for this book, and he invests capital in circulars and postage, to say nothing of the rare talent displayed in writing such a touching production. We charge M. nothing for the advice to go to work on his own plan and save this outlay.

MEDICAL HUMBUGS.

A friend in San Jose, California, sends a request that we show up the "New York Medical University" as a notorious humbug, as he has nearly killed himself by taking their "vile nauseating compounds." This gentleman can not have read the *Agriculturist* carefully, as we long ago stated that there was no such "University," except so far as some quack medicine dealers chose to call themselves one. Medical colleges—a "Medical University" is a misnomer—never advertise medicines or establish "Agencies" . . . Here is our old acquaintance, the Rev. Joseph T. Inman, whom we had for a long time lost sight of. Joe has turned up again, and is on the "South American Missionary" doodge yet. Intelligence of Joey T. comes this time by way of Grinnell, Iowa, where a good person is concerned because such a quack has ensconced himself in the Bible House. That shows where Joseph is "cute." Everybody does not know that one of the regular P. O. Stations is at the Bible House, and it looks quite the thing for a "Rev." to have his letters go to a place with so good a name. Inman is one of the humbugs of the past generation. . . . "The National Surgical Institute" has a branch, this time in Atlanta, Ga. Our Atlanta correspondent will find that we said our say about it last year. The persons who run it claim to be regularly educated surgeons. If so it makes the matter so much the worse; ignorant quacks might be excused for issuing such circulars, but for educated men—pah! . . . Here is another "Rev.," and this one's name is Edward Burnett, and he hails from Albany. The Rev. Ned plays the same old tune—he was a missionary. It was in Southern Asia this time, and he has sufficient of this world's goods (lucky boy!), and he does

not want to realize money (they never do), and he wants to "drive disease and death from the happy fireside" (that's right, go for 'em), and he sends his recipe "to you, fellow sufferer, from a sense of duty" (how lovely), and alas! that it should be so, people can not conveniently get the herbs of the prescription in their own town (or he might add any other), and although his time is very much occupied he will just put it up himself for \$3.03. How charmingly precise, but the Reverend Edward Burnett is some at figures, and as he will in no case "ask or accept a profit on the medicine," he has got the cost figured down to a dot—that three cents must convince the most skeptical of the self-sacrificing nature of this most excellent man. Burnett, don't you laugh yourself at the fools who get caught with this very stale old trick? Why the Rev. Inman mentioned above is ahead of you by ten or fifteen years. If you are a minister you should have respect enough for the calling to lay aside your title when you dabble in quackery. It looks more like a case of stealing the "livery of heaven to serve the —" Well, you know the rest.

COUNTERFEIT MONEY OR "QUEER"

seems to have revived a little since the panic subsided. It is the same old story over again, and it is of little use to publish names, as one rascal has no end of aliases.

ANY PARTY BY THE NAME OF CHASE

who wishes to go in for a share of that estate valued at \$386,000,000 (no odd cents) can take one step towards it by investing \$5 in three sheets of genealogy. Money sent to the Treasurer at Fall River, Mass., or to another Chase in Ohio, "will be safe," so says the circular, and we haven't the least doubt of it. Here, all you Chases, are all these millions lying round loose all for the want of a few hundred dollars to send a Chase to Europe on a wild goose chase. Who ever heard of one of these wonderful estates being secured by the heirs?

The Howard Mill.—"N. F. B.," Lexington, Ky. The Howard Mill may be ordered through any dealer of farm implements in New York, several of whose names appear in our advertising columns.

Asbestos Roofing.—"N. R.," Kinderhook, Ohio. About a dozen years ago we roofed a building with this roofing, as did several other persons in the neighborhood. We do not know of an instance in which it failed to give satisfaction, and in our own case, with an occasional coating of cement, the roof was in good order three years ago, since when we have not heard of it, and it is doubtless so now. The roof should have a slope of at least one foot in sixteen.

Arbor Day in Iowa.—A circular from the Iowa Horticultural Society names April 20th as Arbor Day. The appointing of a day for the planting trees throughout the state originated with Nebraska two years ago, and other states are following her example. The circular gives a list of premiums, varying from \$4 to \$30 each, for the greatest number of evergreen and the various deciduous trees planted. The premiums are to be awarded in October next, and only those trees that are then alive are to count. Besides the premiums and regulations, the circular gives notes on the proper methods of planting, etc. Copies may be had of Jas. L. Budd, Shellsburg, Benton Co., Iowa.

The Snyder Blackberry.—It is not our custom to say much about new fruits until we have tested them. As several have asked in regard to the Snyder Blackberry, a comparatively new variety, we have made inquiries and give their result without knowing anything of the fruit ourselves. The variety was found on the farm of a Mr. Snyder, whose name it bears, near Laporte, Ind. It has been in cultivation since 1851, but has not as yet been very widely distributed. We have before us letters from several well-known Western horticulturists, all of which speak of the good quality of the fruit, the prolific character of the plants, and especially of the surpassing hardiness of the variety. Indeed, hardiness is the great merit claimed for the Snyder by those who are introducing it, and their statements are sustained by what seems to us abundant evidence. At all events we have ordered some plants of Mr. J. R. Gaston, Normal, Ill., and shall know more about them hereafter.

Nebraska and Minnesota Lands.

There are no lands better adapted to the growth of wheat or grass than those in Nebraska and Minnesota. The fine valleys of the Missouri, the Platte, and the Red rivers in these States are now opened to settlement by the Burlington and Missouri, the Union Pacific, and the St. Paul and Pacific Railroads. These companies are anxious to dispose of their lands and give every facility to purchasers by means of exploration tickets, reduced fares to colonies, cheap prices on the easiest terms, and

convenient accommodations to immigrants. Thousands of successful settlers are now making comfortable homes in these rich and healthful valleys.

The Massachusetts Horticultural Transactions for 1873 are at hand. The reports of the committees are full and interesting, and the volume is produced in a very handsome style.

Play and Profit in My Garden, by the Rev. E. P. Roe.—When this book first appeared we commended it as one of the most genial of horticultural publications. Since then its publication has been assumed by the Orange Judd Company, and a re-issue is now ready. It is not only pleasant reading, but instructive and eminently timely.

Eggs and Plants by Express.—"T. T.," Healy, Montana. The vitality of eggs, carried from New York to Montana, would almost certainly be destroyed. It would at any rate be cheaper to procure a trio of fowls, which could be sent safely, than the eggs, although the first cost would be greater. Good fowls can be procured at Chicago or in Minnesota. Trees and plants, if properly packed, can be safely sent ten thousand miles if necessary. Trees have been safely shipped from Rochester, N. Y., to Australia.

Close Breeding.—We have received, through the courtesy of Professor M. Miles, advance sheets of the Report of the Secretary of the Michigan State Board of Agriculture for 1873, containing a very valuable paper upon Close Breeding, by Professor Miles, and which was substantially given in a lecture before the American Association of Short Horn Breeders, at their meeting at Cincinnati, Dec. 3, 1873. This paper is a remarkably effective defence of the practice of close or "in and in" breeding, as a scientific process in the hands of intelligent and thoroughly competent breeders. The accumulation of facts presented in this paper furnish an irresistible argument in favor of the position assumed by the Professor, which might perhaps be epitomized in the statement that close breeding is only the means of perpetuating the qualities which have been gained by other means, and does not in itself necessarily improve or injure animals, while, nevertheless, "close breeding" in the hands of incompetent, uneducated, unscientific persons is to be discouraged as almost certainly an injurious practice. This paper should be read and carefully studied by every stock breeder.

Vick's Chromo.—James Vick, the well-known seedsman, of Rochester, sends out a floral chromo annually. The one for the present year shows a large cross decorated with flowers, and is exceptionally good.

The Exhibition in Chili.—The government of Chili, the most progressive of the South American republics, announce their Second International Exhibition at Santiago, in September, 1875. This is a fair worthy the attention of our inventors and manufacturers. These and all others interested can obtain programmes from A. Villarreal, office of Ribon & Munoz, 52 Pine street.

Book Notices prepared for this month are necessarily crowded out. We would like to give especial notice to the very excellent "Elementary Science Series," now being issued in rapid succession by G. P. Putnam's Sons, N. Y., but have not space.

Landscape Gardener.—F. X. Heissingcr, from Germany, has established himself in New York as a landscape gardener. He has had much experience abroad, and his designs that we have seen show both taste and skill.

Peristrophe.—It is not a little surprising to read in the N. Y. Weekly Tribune the following: "Among the new plants out for the first time, none gave us more satisfaction than that lovely little golden-leaved beauty, or to load it with its full title according to the books, *Peristrophe angustifolia aureo-variegata*." As an offset to this gushing paragraph, we would say that the plant (which by the way is not new) though very fine for greenhouse decoration, has for several years proved perfectly worthless with us as a bedding plant. We have seen it in various gardens from Massachusetts to Georgia, and all we have seen who tried it are quite disgusted with it as an open-air plant.

Value of Corn and Bran.—"J. H. S.," Bourbon Co., Ky. Corn and bran can not be compared with each other as feed because neither can be fed alone to the best advantage. But equal measures of each ground together will make probably the most nutritious feed for either hogs or horses and a most excellent feed for cows.

Cabbage Plants.—Sometimes one can drop nothing and make trouble. Peter Henderson & Co.'s advertisement for last month offers plants of Jersey Wakefield Cabbage at \$1 per thousand. In making up the page a 0 dropped out. It should have read "\$10 per thousand"—and cheap enough at that.

Your Name.—Miss "R. E." writes to know if a certain journal is still published. Information of this kind, of interest to but one person, can only be given by mail. All making such inquiries should send a stamped and directed envelope, a directed postal card, or at least a letter stamp. Had the question been other than of personal interest, it would not have been answered, as the lady did not send her name. We can not notice anonymous letters, and we hope all readers will bear this in mind. Sign letters as you please, but give us the real name beside.

Purdy's Chromo.—A. M. Purdy, publisher of the Small Fruit Recorder, Palmyra, N. Y., sends out a fine fruit piece. It comes at the very moment of closing these pages, and we can only say that it is a very handsome and creditable production.

Sanford Corn.—"A. S.," West Brighton, N. Y., sends us his experience with what he purchased as the Sanford corn and which he understood was to be an early corn. It turned out to be remarkably prolific of fodder, but very sparsely so of seed, and his crop, planted on the 15th of May, failed to ripen at all, yielding about 30 bushels per acre of unsound corn.—Our own experience with this same corn was very similar. With us it was inferior to the common white flint corn. It would, however, probably succeed better in a lower latitude than that of New York.

Eleagnus parvifolius.—"S.," La Porte, Ind. This is a very neat shrub, and promises well as a hedge plant, but has yet to stand the test of extended trial. We saw a good stock of it in the nursery of Thomas Meehan, at Germantown, Pa.

Safe Oils.—"C. M.," Springfield, Mo. If there is no inspector of oils in your State whose brand is a safeguard, you must test the oil yourself. No oil should be used which gives off a vapor that will flash at a lower temperature than 110°. An inch of oil put in a deep tin cup and heated should not give a vapor that will take fire when a match is held above the oil at a less temperature than 110°. It is not convenient for every one to do this, as few have a suitable thermometer, but every grocer who sells kerosene oil should have an apparatus made for the purpose of testing it, and be able to assure his customers of its safety. Insist that your grocer shall give you good oil.

Poultry Book.—"C. H. H.," La Grange, Mo. L. Wright's Practical Poultry Keeper is probably the best work for those who desire to keep poultry for profit. It must be remembered that no one book of moderate size could be exactly adapted to every person's particular requirements. It will be always necessary therefore for the student to adapt his own circumstances to the general rules or ideas therein given, which any person of ingenuity ought to be able to do. If one can not do that, but must have particular directions for every emergency, he is not the man to succeed with poultry, which require more tact in their management than any other stock.

North-western Dairymen's Association held its annual meeting at Woodstock, Ill., commencing February 10th. The attendance was large and the proceedings interesting. The dairy interests of the North-west were shown to be exceedingly flourishing and the business profitable. The production of cheese had been sufficient to displace Eastern cheese to a large extent in Western markets and leave a surplus for foreign export. The burden of the speaker's remarks were the improvement of quality of cheese and butter by means of care in feeding, perfect cleanliness in milking, and in the dairy, order in every department, and honesty in all dealings. The following officers were elected: President, S. Favill, of Missouri; Secretary, G. E. Morrow, of Wisconsin; Treasurer, R. R. Stone, Illinois, with fifteen Vice Presidents, representing Iowa, Illinois, and Wisconsin.

Breaking Prairie.—"J. H. B.," Hastings, Neb. The common way of breaking prairie sod renders it necessary to plant a crop of sod corn or let the sod lie fallow until it rots, when it may be cross plowed. It is best to follow the custom of the country in this respect, especially for new beginners and those from England, where everything is so different from things here. By using two plows, one following the other, in

the same furrow, the sod may be covered with mellow soil, but it is doubtful, even then, if clover or mangels would thrive the first year. The sod requires reclaiming by a process of rotting or decomposition before it is available as food for plants. We would advise you to keep the seed until next year, when you will have this year's breaking to replot, and break all you can this spring, so as to have as large a crop of corn as possible, which will doubtless be found useful.

Book on Horses.—"A. B.," Cass Co., Iowa. The best work we know of upon the management of horses is "The Horse in the Stable and the Field," by Stonehenge; price \$3.50, at this office.

As to Patented Articles.—"G. B.," Oneida Co., N. Y. If patented articles have it not distinctly stamped or marked upon them that they are patented and the date of the patent, then the patentee must notify the one who infringes before he can enter a suit against him. The butter-tub you refer to may or may not be patented; we can not say as to that, but it is very certain that oaken butter-tubs, which are larger at one end than at the other, have been in use for many years back, and, unless there is something else about them which is novel, there can be no valid patent on such a tub. For all information about procuring patents apply to the patent department of this office.

Dog Power.—"L. B.," Oxford, Ohio. Among the really useful dog powers probably the best is one made on the plan of the common horse power; it is sold for \$25 and may be driven by a sheep or a calf.

Tallow Scraps.—"J. J. B.," Monroe Co., N. Y. Tallow scrap contains skin and more or less fat as it has been well or badly pressed. The fat is useless as manure, so that the skin is the only valuable part, and the value obviously depends upon the character of the scrap. For manure we should hesitate to pay \$20 a ton for it, but would do so to use it as food for hogs or poultry, for in this way the fat and digestible parts would be utilized, and the skin or indigestible parts would be in much more valuable condition for manure after passing through the animals.

"Bromophyte."—"C. H.," Bullitt Co., Ky. We do not know of what this fertilizer consists. Any fertilizer, the composition of which is kept secret, should be regarded with suspicion. We will not advertise or advise the use of any compound of this kind.

Delay in Replies.—If our correspondents, when writing for information along with other business, would remember our frequent request and place their remarks or queries upon a separate piece of paper from that on which they write about their other business, inclosing both in the same envelope, they would much facilitate the reply to their inquiries. Letters sometimes lie over a whole month for want of this precaution.

Contraction of the Hoof.—"J. H. D.," Stouts, Ohio. Contraction of the horn of the hoof is an effect and not a primary disease, and the lameness is a symptom of the obscure disease which causes the contraction. It may be caused by chronic founder or laminitis or by a diseased navicular bone, either of which is incurable. If it is not caused by the above it may result from bad shoeing and cutting away the frog, in which case a Goodenough shoe should be used and the frog in future be left entirely intact. Contraction of the hoof rarely or never occurs when the frog is allowed to come to the ground.

Government Help for Colonies.—Charles Stumm. The government gives no help in the shape of seed, implements, or passage money to homesteaders. It is enough that it gives a free homestead, upon which a man must work his own way to independence. We do not advise persons without means to go on to a homestead. They suffer hardships and disappointments, which are apt to disgust them with their position.

Frost Disturbing a Cellar Wall.—"B. R.," East Killingly, Ct. When the fall rains saturate the ground and the winter frosts follow, the wet ground in freezing expands greatly. This expansion pushes in the cellar wall, and as the north side is the coldest that side suffers most. The remedy is to have a drain to carry off the water from around the house, for when the soil is dry or nearly so frost has but little effect upon it.

Heat for a Compost.—"C. H.," Hillview, Ky. A compost heap of stable manure and leaves will heat up very rapidly and will soon be in danger of fire unless plentifully supplied with moisture or

turned over to reduce the fermentation. As a rule nothing but a loss is made by keeping manure piled up, so as to heat very rapidly. We would draw it out and spread it at once where it is to be used.

How Many Bundles of Oats to an Acre.—"T. A. M.," Owensboro, Ky. The number of bundles of oats there may be to an acre upon good land depends upon the size of the sheaves. The best crop we have raised, which is probably more than the average and of which on that account we kept a record, amounted to nearly 600 sheaves to the acre. The yield of grain was one bushel to a dozen sheaves. It was a large strawed variety with heavy grain, the seed of which was imported from Nova Scotia, and therefore might not be a fair test, but it is the only one that occurs to us.

Plaster upon Wheat.—"A. H.," Lithopolis, Ohio. We have seen no reason to believe that plaster has any benefit whatever upon wheat. Clover, corn, peas, potatoes, and perhaps oats are the only crops for which we have found it of service.

Preserving Posts.—"W. F. C.," Albany, N. Y., sends us a plan for preserving posts a receipt which has been widely published in both agricultural and scientific papers, the editors of which ought to have known better. It is to paint the posts with linseed oil in which powdered charcoal has been mixed. This is said to make them indestructible, but it can have no more effect than any other paint. The charcoal, being merely a surface application, can not prevent the decay which takes place in the interior of the post from natural causes, nor can it prevent moisture entering by way of the minute cracks which are found in the timber; and where moisture and change of temperature occur, decay takes place, unless there has been a chemical change in the wood by some active, penetrative agent.

The Gardeners' Monthly.—What is the matter with it? Has it changed editors, or what has happened? In the March number a correspondent asks the editor to tell him something about "Jerusalem artichokes." Whereupon, after mentioning the proper artichoke, some learned writer says: "Another artichoke is that called 'Jerusalem.' It is a sort of sunflower, and 'Jerusalem' in this case is nearly the sound in English of a French word which signifies sunflower." We always thought a knowledge of ancient and modern languages a good thing for an editor to have, and we are now more than ever convinced of it. The French names for this so-called artichoke are *Topinambour* and *Poire de terre*, and that for the sunflower in general is *soleil*. If any one can make these words sound like Jerusalem we have no doubt it is the learned friend of the G. M.; but we would suggest that he would meet with better success if he tried first on the Italian word for sunflower, *girasole*. The article continues: "We suppose it was called artichoke by mistake, by some one who did not know any better, and then sunflower had to be tacked on to distinguish it. This [what? having sunflowers tacked on?] happens even in this day to the best of us." A sad moral reflection, but behold how it is pointed and adorned: "The editors of *HEARTH AND HOME* and *American Agriculturist*, for instance, are among the most intelligent in the country, and are seldom caught asleep, but [so Jove sometimes nods] they did once figure and describe a plant, which is really *Talium patens variegatum*, as *Boussingaultia Lachauxii*. So, for distinction, we have to say Humboldt's *Boussingaultia* when we mean the real Madeira-vine, and Thurber's *Boussingaultia* when we speak of the other." There! if that does not make the whole Jerusalem artichoke business "as clear as mud in a wine-glass" then there is no virtue in illustrations. What interests us most in this remarkable illustration of the statement that editors, like common mortals, are liable to make mistakes or have sunflowers "tacked on to distinguish" them—we hardly know which—is the positive assertion that the editors of *HEARTH AND HOME* and *American Agriculturist* have "figured and described" a plant under a wrong name, and actually done this in the case of *Talium patens variegatum*—which they did figure and describe as *Boussingaultia Lachauxii*. As at the only time when this flagrant error is likely to have been imposed upon a deluded public *HEARTH AND HOME* was edited by Mr. Donald G. Mitchell, we leave him to excuse himself to the tribunal of the G. M. (not Great Mogul, but Gardeners' Monthly) as he best may. But for ourselves, the little we can say must be in extenuation, and in the humble hope of mitigation of sentence. A new plant was introduced for the beauty of its leaves alone. Now, we appeal to the Gardeners' Monthly if it is an un pardonable sin, and one to be remembered for years and to be brought up against the one who commits it in its own pages, where to be held up as a warning and terror to evildoers is better than to be praised elsewhere? Is he the

first botanist, or even the first editor, who ever made a mistake in naming a plant? If G. M. will admit this, then we will inform him that the editor of the *American Agriculturist* never, in that paper or anywhere else, did publish *Talina patens variegatum* as *Boussingaultia Lachaumii*. G. M. says we did. We are sorry to differ even so slightly with our friend, and to assert that we did not! G. M. is great for presenting theories, and as such they are often amusing and interesting as the outcomes of an active imagination, but we thought we could always depend upon its facts—but, alas! he says we did that which we did not. Do we accuse the editor of G. M. of willful misrepresentation? Not at all, for he would not be guilty of that. To show that "even the best of us" are sometimes "caught asleep," we will now tell our venerable friend what foundation he had for the charge which we are obliged to deny. At the full exhibition of the Pennsylvania Horticultural Society in 1869 there was exhibited a small variegated-leaved plant, with no flowers, though if we mistake not a few buds were visible; it was labelled "*Boussingaultia Lachaumii*." When we were making up the Horticultural Annual for 1870 Mr. Peter Henderson brought us the same plant to figure, and in his report upon the new plants of the year he had a notice of it. We do not now recollect under what name Mr. H. had it, but recognizing it as the plant we had seen at Philadelphia we were at once put upon our guard. Philadelphia is admirably correct in some things, but in names of plants she is loose unto prodigality; plants in the city are so frequently called "out of their names," that the bad example extends for many miles around. For instance, one florist on the Darby road calls an *Eulalia* an *Imperata*, a mistake no one who knows anything about the structure of grasses would make; and even from Germantown we have a catalogue in which the pretty *Festuca glauca* is disguised as *Agrostis glauca*, which, as both are grasses, is perhaps not so bad, but then we have *Astilbe Japonica* taken out of its natural family and called a *Spiraea*; and we might cite numerous other instances of the extent to which this bad example of Philadelphia had spread. In making up the Annual we thought best to be very cautious with the Philadelphia name of this plant, as our venerable friend will see if he turns to page 114 of the Horticultural Annual for 1870. He will there find: "*Boussingaultia*? var. *variegata*." Which means that it may be a variegated *Boussingaultia* and may not. We congratulate G. M. that, after the lapse of five years, he has been able to decide what the plant is; but regret that he should have endeavored to give prominence to his profound knowledge by using our object ignorance as a foil. We are not in favor of the "you're another" style of criticism, but as we had taken the editor of G. M. up on the *Centaurea Americana* question he was bound to hit back somehow, and chose a very unfortunate topic, lodged in by the ears, to a place where it is no more *apropos* than a quotation from the multiplication table. We do not consider these little vagaries of the editor as detracting from the general character of the Gardeners' Monthly, which perhaps needs an occasional blemish to make its real excellencies more conspicuous.

Lucern.—"G. T. W.," Wallfleet, Mass. Lucern requires a rich, dry soil, such as a warm gravelly loam with open subsoil. Sandy land is not suitable to it, unless it has a strong loamy open subsoil. This crop exists more upon the subsoil than the surface, after it has become established, but it can not be established with any profit upon any but a rich, mellow surface soil.

American Turf Register and Racing Calendar for 1873 contains a synopsis and reference record of the results of races in the United States and Canada during that year. Published by the Turf, Field, and Farm Association. Price \$3.00.

Improving Southern Fields.—"M. A. L.," Point Pleasant, Mo. To get a stand of grass we would suggest that you should plow and sow an early crop of cow peas, and when they are in blossom plow them under. Repeat with another crop, which plow under, and sow wheat with timothy in October next. This will be far better than a bare fallow, and the cost of the seed will be a very cheap price for the green manure plowed into the soil.

How to Feed a Colt.—"H. W. H." It is the early care of the colt which makes or mars the horse. The danger is generally in starving him rather than over feeding. The point to be aimed at is to keep him growing. He may be fed from two weeks old. At that time, in addition to the milk from the mare, he should have a handful—at first—of oatmeal or oats, soaked in sweet cow's milk or water. If the mare does not give much milk this may be gradually increased up to two quarts of oatmeal or oats in a few weeks. No corn should be given to a colt at any time, and all the

oats he will eat up clean and with an eager appetite may be given without danger. He should be brushed daily, so as to keep the skin clean and free from scurf. It is well to have a closed stall next to the mare for the colt, in which he may run loose when not at pasture.

Harrowing Wheat.—"T. F. H.," Sun River, Montana. We have never heard of any injury having been done to the young wheat by harrowing with the Thomas harrow; on the contrary the experience of those who have tried it is favorable. We have harrowed wheat with the common harrow even with very great benefit to the crop. We have also drawn a harrow, from necessity, across the corner of a field of young oats, and at the time supposed we had destroyed the plants, but the strip over which the harrow passed was afterwards much the best of the field.

Soap and Glue Refuse.—"A Subscriber," Kent Co., Mich. The refuse of glue or soap works is a valuable fertilizer. That from the glue works is the most valuable. What its actual money value is depends upon so many contingencies that what might be worth 10 dollars per ton in one place might not be worth more than one dollar elsewhere. We have paid \$2 per ton for glue refuse, a large portion of which was water. We found it very valuable as a dressing for grass lands or for vegetable gardens.

The best Hay Fork.—"T. A. J.," Ontario Co., N. Y. While persons' tastes differ as to implements, our experience is that the double harpoon hay fork is the best for hay, straw, or sheaf grain of any we have used. All these, whether long or short, may be unloaded with it, and manure may be loaded with it equal well. A neighbor, who is a large and intelligent farmer, last season unloaded his grain from over 150 acres with one of these forks in a most satisfactory manner.

Bed-Bugs.—"M. K. W.," Nashville, Tenn., writes that she does not care to have corrosive sublimate around on account of the children. Finding the children were bitten, she put their beds upon the floor, and here they were worse troubled than ever. The enemy was traced to an old lounge. This, as well as the cracks in the floor, had its joints thoroughly scalded with boiling brine. A few repetitions completed the job.

Ashes for Peach-Trees.—"Taylor." There is no better fertilizer for peach-trees than wood-ashes.

Buckwheat.—"W. B.," Templeton, Mass. There is no crop that responds more quickly to good soil and cultivation than buckwheat. It is called the "lazy man's crop," for the reason, that however badly it may be put in, there is always something to be gathered at harvest. For a good crop the soil should be well plowed; the seed may be sown upon the plowed ground and then harrowed in. A dressing of 20 bushels of lime or 100 pounds of plaster per acre is very beneficial to this crop. An excellent crop may be taken from a sod that is plowed early in July, after the hay has been taken off, which may be followed by corn or oats the next spring. One bushel of seed per acre is sufficient; on very good soil three pecks is enough.

Varnishing Chromos.—"Constant Reader." Mastic varnish, usually called picture varnish, is the kind used. If you have but one chromo that needs varnishing it will be cheaper to send it to some picture store than to buy varnish and a proper brush.

An Iron Dish-Cloth.—"Mr. George Smith, Farmerstown, Ohio, sends us an "iron dish-cloth," which is like a piece of chain-armor, and useful for scouring pots and other cooking utensils. Mr. S. says it has long been in use in his vicinity, but is not known generally. They have been kept by our furnishing stores these many years, but that does not make them any the less useful.

Insects on Roses.—"Franklin Street," Portland, Me. We can not tell you how to best fight insects unless we know what they are. You give no description, but only say, "an insect which eats off the tips of the buds when about half grown." This looks like the work of the rose-bug, a small drab-colored beetle. Nothing will do for this except hand picking. In early morning it may be readily shaken off, caught, and killed.

Dairy Business in the West.—"J. A. W.," Boston. There are many openings for the dairy business in the West. Many localities are able to furnish milk enough for a cheese factory, which would be

a home industry well worth encouraging. Either Iowa or Kansas would furnish many such localities if J. A. W. would go thither and seek them out. It is more than probable that a short notice in our advertising columns would elicit much information as to these places. \$3,000 would put up a factory such as is needed, and surplus capital might if desired be employed in keeping a stock of dairy cows in addition.

Primula Japonica.—"A. G. F.," Portland, Me. We think this will prove hardy, but we have had so few plants that we have not cared to try them.

Poetry.—"C. H. H.," sends us a poem which we must decline for two reasons: 1st, we do not publish any poetry that has appeared elsewhere; and 2d, we do not print poetry at all. So much verse was offered us, that several years ago we found it expedient to make a rule that we would publish nothing called by courtesy "poetry," and we have seen no reason to depart from it. Our old readers are aware of this, and we may do a service to some of our new friends by reminding them of it.

Monarch of the West Strawberry and Herstine Raspberry.—"Scott." Those who grow this strawberry on the light lands of southern New Jersey speak well of it; others who have tried it on heavy soil find it a poor variety. The Herstine Raspberry is in every respect superior as a fruit to the Philadelphia. The winters of '70, '72 and '73 injured it badly with us—but so it did other varieties counted hardy.

Utilizing Night-Soil.—"P. H. R.," Liberty Corner, N. J. In the *Agriculturist* of October, 1872, there is an article with illustrations entitled "How to Empty a Cesspool." In that will be found directions for preparing the contents for use. To use the preparation it is spread upon the surface of the soil, to be manured and harrowed in as near the seed as possible.

Horticultural Humbugs.—Lafayette & Co. appear no more, but their mantle has fallen upon shoulders quite worthy of it. A store up Broadway is now in full blast, and offers the same wonderful things, the merits of which are set forth in the same Gallo-Yankee language, and illustrated by as phenomenal drawings as were the worthless wares of Lafayette & Co. By way of curiosity we made a visit to the establishment, and heard and saw these horticultural marvels: Apricots weighing one pound each, plums without stones, raspberries with "large fruit as a egg of fowl," are among the choice things of the catalogue. These are as nothing compared to "*Fragaria Africana arborescens*," strawberry in tree, having a fruit similar to this of a herbaceous fruit, much larger, with the same perfume, a new kind." These are *grafted on quince* (!), considering which \$3 does not seem so very high for a plant. Then a grape, which is not here but is coming, bears bunches weighing fifteen pounds, and ripens in the open air in July. The asparagus, which can be cut in ninety days from the seed, is now sold at only two cents a seed, while Lafayette & Co. charged four cents. In the way of flowers, we can only mention pansies of unheard of shapes at twenty-five cents a seed; "*Gentiana Africana*," which is in blossom during nine months, and "*Calypso borealis* of China, remarkable by its dimension and its agreeable smell, in blossom during three months." The catalogue concludes with "*Fragaria arborescens Africana*"; whether it is different from the previously mentioned "*Fragaria Africana arborescens* we do not know, but presume it is as it "produces fruit weighing sometimes one-half kilog. (one pound), delicious, four varieties." This bold imposture is carried on every spring, sometimes under the name of Lafayette & Co., and sometimes under another name, but they all have similar things and similar machinery to aid them in disposing of them. Men of means and intelligence will go to these fellows and purchase stuff for which these preposterous claims are made, and we have little sympathy for such people when they get humbugged. It is with the amateurs with small means that these chaps do the most mischief. These, with a great love for flowers, but without knowledge enough to see that the representations made by these travelling dealers are simply impossible, will purchase the trash, and throw away for nothing a sum that would have given them much enjoyment if expended for good things. These fellows, with their impossible monsters, have some good-looking stock, such as roses, camellias, and the like, which give their place a respectable appearance. It is probably impossible to stop these swindlers by any legal means, as by the time a purchaser finds out the fraud they are far away, and next year another set (probably of the same gang) appear. We give the present set credit for one thing: they have left the "blue rose" out of this year's catalogue. No reader of the *Agriculturist* will, we trust, be taken in by any such

representations as those we have quoted. Remember that our own regular dealers have everything in the way of seeds, flowers, and fruits that is worth growing, and if a valuable new thing is offered in any part of the world, the contest with them is to see who shall introduce it soonest.

Petroleum for Priming.—"S. M. W.," Shippensburg, Pa., writes that "an experienced car-builder informs him that even the best mineral paints will not adhere to wood that has been oiled with petroleum some weeks before painting. His plan is to apply the crude petroleum as hot as possible, and put on the paint as soon as the petroleum has fairly cooled. Result much more satisfactory than when the petroleum is applied cold and the wood not painted for some weeks afterwards." This is quite probable. For hard wood the lighter oil will soak in more readily than the heavier oil, and the hotter it can be applied the more rapidly will it be absorbed. For pine or hemlock, except the weather is very cold, it is not necessary to heat the oil. Paint will not adhere well to the oiled surface unless the petroleum is absorbed by the wood. Last summer we put petroleum on to a new pine double wagon box. We went over the box two or three times at intervals of two or three days, or when we happened to think of it. We probably got on three or four gallons of oil. In two or three weeks afterwards we painted it with Averill paint and found no trouble. The paint adhered as well as could be wished. We put on two coats, and the box looks as smooth, glossy, and firm as if made of the best of hard wood. In cool weather, and especially with hard wood, it would undoubtedly be advantageous to apply the petroleum hot, for the simple reason that it would penetrate deeper into the wood. How long or how short a time elapses before the mineral paint is applied is of little consequence, provided the petroleum has been absorbed by the pores of the wood. This is the main point to be observed. [This comes from one of our associates who has had much experience in the use of petroleum, and as he passed much of his life in a chemical laboratory it does not occur to him that anything can be dangerous. So we must add that if petroleum is to be heated it must be done with the greatest caution or it will take fire. The safest way will be to set the can in a kettle of hot water out of doors, and be sure not to bring a lamp, light a match, or allow flame of any kind near the place where the work is going on.—Ed.]

Catalogues Received.

Last month we left out other matter for the sake of space to notice the catalogues of our friends, the dealers. We supposed that we had at hand the majority of the catalogues, and were willing, for once, to give a separate mention of each one with some notice of its peculiarities. Since then we have received a large number more, and though these are of the same importance as those mentioned last month, we can not, owing to the claims of others upon our space, give other than the briefest notice.

GENERAL NURSERY STOCK.

- J. W. ADAMS, box 1,340, Springfield, Mass.
 ORTO & ACHELIS, Westchester, Pa.—Large stock; wholesale and retail.
 A. HANCE & SON, Rumson Nurseries, Red Bank, N. J.—Also greenhouse plants.
 REISIG & HEXAMER, New Castle, Westchester Co.—Specialties, small fruits, particularly strawberries and seed potatoes.
 P. T. QUINN, Newark, N. J., besides pears offers small fruits and various vegetable plants.
 S. J. ALLIS, Erie, Pa.—Grapes and other small fruits.
 GREENHOUSE AND BEDDING PLANTS.
 GEORGE SUCH, South Amboy, N. J.—General collection with gladiolus as a specialty. The neatest catalogue yet seen from Europe or this country.
 S. B. VREELAND (Greenville), Jersey City, N. J.—General stock with the fine *Bouvardia Vreelandii* as a specialty.

- W. B. WOODRUFF, Westfield, N. J., besides greenhouse and bedding plants has a full list of vegetable plants, and still another new tomato—"Robert."
 JOHN SAUL, Washington, D. C.—A huge catalogue, embellished with a fine colored plate of the new "Ball of Snow" Abutilon.
 W. C. WILSON, Astoria, N. Y., and 43 West 14th street, N. Y.—An immense general assortment with a number of specialties not offered elsewhere.
 MILLER & SIEVERS, San Francisco, Cal.—A catalogue so full as this is a surprise to us, who knew San Francisco when there was not a florist west of the Rocky Mountains. Send your other catalogues.

DINGEE & CONARD Co., West Grove, Chester Co., Pa., make a specialty of roses, which they send by mail at very low prices. The catalogue is valuable for its sensible cultural directions.

P. J. BERCKMANS, Fruitland Nurseries, Augusta, Ga., is largely engaged in floriculture as well as the nursery business. Besides a general stock he has many things suited to Southern gardens only. Prices astonishingly low.

SIDNEY WILKINSON, Providence, R. I.—We are glad to see so fine and full a catalogue from a city which for one of its size has heretofore had very few florists.

OLM BROTHERS, Newark, N. J.—This large establishment always presents some novelties, and it has a number in this year's catalogue.

WM. J. HESSER, Plattsmouth, Nebraska.—A more complete list than one would expect to find in a place which but a few years ago was "on the frontier."

GREEN, BEECH & ARTER, South Oil City, Pa.—Send an illustrated catalogue of plants and seeds.

SEEDSMEN.

D. M. FERRY & Co., Detroit, Mich.—This is one of the largest seed-growing establishments in the country, and their descriptive catalogue is very full and complete.

JOHN SAUL, Washington, D. C., has, besides from his nursery, a seed store opposite the Patent Office.

SCHLEGEL, EVERETT & Co., Boston, Mass., have besides the usual list many peculiar and Boston—and therefore very good—"notions" in the way of vegetables and flowers.

J. M. THORBURN & Co., No. 15 John street, N. Y., publish each February a list of *Tree and Shrub Seeds*. Those who write asking where such things can be had should bear this in mind.

HOVEY & Co., Boston, Mass.—For nearly 40 years have this firm sent out each year their well filled catalogue, and yet they keep up with the times.

AARON LOW, Essex, Mass., grows garden and flower seeds, and his catalogue tells all about them.

JAMES FLEMING, 67 Nassau street, has a very full illustrated catalogue of vegetable and flower seeds, prefaced by a handsome colored plate of Double Zinnias.

VICK'S FLORAL GUIDE.—Mr. James Vick, of Rochester, extends his catalogue over the whole year and makes it a quarterly. No. 2 has many interesting items and a "pronouncing vocabulary of botanical names," which would be more useful if it were more correct. What can he mean by telling us that *coix* is pronounced "coy!" Other words also needs revising.

W. H. SPOONER, Boston, Mass., puts out his catalogue as a "Garden Guide," and a very creditable one it is.

CHARLES SIZER, Mount Lebanon, N. Y., sends out what he calls a Shaker Catalogue, which is in appearance very much like the catalogues sent out by the "world's people," and contains no intimation that it is issued by any Shaker community.

V. P. DOW & Co., Albany, N. Y.—Seeds, Rustic Work, Implements, etc.

IMPLEMENTS, FLOWER-POTS, ETC.

GARDENER B. WEEKS, Syracuse, N. Y.—Cheese and Butter Factory, and Dairy Supplies and Apparatus. Well illustrated.

A. H. HEWS, North Cambridge, Mass., have an illustrated catalogue of machine and hand made pots, etc.

SNOW & COOLIDGE, Wachsett Pottery, West Stirling, Mass., also send a catalogue of similar wares.

EUROPEAN CATALOGUES.

E. G. HENDERSON & SON, London, send an immense catalogue of seeds of all kinds, including all the new things.

ALEGATRIE, Lyons, who introduced the new double white and other double Pelargoniums last year, offers a new set, raised by Jean Sisley and others, and a new lot of Carnations.

Planting Trees upon Highways.

We have been requested to publish the law in regard to the money allowed for planting shade trees on the side of the roads in the State of New York. There was an act passed April 26, 1869, entitled, "An Act to Encourage the Planting of Shade Trees along the sides of the Public Highways" (chap. 322). This act was amended May 3d, 1870, so as to include fruit trees (chap. 595). We give the act as amended, and as it now stands:

"Section 1.—Any inhabitant liable to highway tax who shall transplant by the side of the public highway any forest shade trees or fruit trees of suitable size shall be allowed by the overseers of highways, in abatement of his highway tax, one dollar for every four trees set out;

but no row of elms shall be placed nearer than seventy feet; no row of maples or other forest trees nearer than fifty feet, except locust, which may be set thirty feet apart; fruit trees must also be set at least fifty feet apart; and no allowance, as before mentioned, shall be made unless such trees shall have been set out the year previous to the demand for said abatement of tax, and are living and well protected from animals at the time of such demand.

"Section 2.—Any trees planted by the side of the public highways as aforesaid, in the place of trees that have died, shall be allowed for in the same manner and in the same conditions as in the preceding section.

"Section 3.—No person shall be allowed an abatement of his highway taxes as aforesaid, more than one quarter of his annual highway tax, and no one shall receive any abatement of tax for trees planted previous to the passage of this act.

"Section 4.—This act shall take effect immediately."

The act has had very little effect. Not one farmer in a thousand knows of its passage. And those who know of the law seem to care little about it. The compensation is too small. A farmer of one hundred acres is assessed say from \$8 to \$12 highway tax to be "worked out." A man, team and plow, wagon or scraper, counts for three days' work, or \$3. So that if a farmer is assessed \$12 all he can get for setting out trees is one day's work for himself and team. If section 3 was stricken out, so that a farmer might be allowed 25 cents each for all the trees set out, it might have some effect. As it is, a farmer who has energy and sense enough to set out trees will not be influenced by the small compensation, and those who have not will pay little attention to the law.

Bee Notes.—Advice to Beginners.

BY M. QUINBY.

Mr. Smith, Pa., writes that "wild Sullendine plant is a perfect cure for bee stings, and mosquito bites." All that is necessary, he says, is to apply the juice immediately, to prevent swelling: He probably means common celandine, growing in wet places. At our association in Utica last February, a member brought what he called an antidote to bee stings, in liquid form. To convince the skeptical of its efficacy he actually brought some bees with him, and got himself stung in two places. To one place he applied the remedy, and the effect of the sting on that did not seem quite so bad as the other, to which nothing was applied. He urged all to make the trial, and found but one willing, but he claimed that he illustrated its efficacy by partial success, at least. Ever since I kept bees, new remedies for stings have been recommended as certain cures. For a long time, I took pains to test them; sometimes a sting would be hardly felt, at others it would be very severe, when both were treated with the same remedy. My impression is, that in cases where the effect is slight, the puncture is slight, but little poison infused, or the bee is not incensed to make the thrust with much vigor. This seems more probable than that we have found an antidote. It is long since I have used anything, and do just as well. I do not wish to deny their efficacy, or even discourage the trial of them; but I trust I shall be excused from implicit confidence, when I have failed in so many cases. Those who have realized that it is easier to avoid contracting various habits in any ease than it is to cure them, will find no exception to the rule, when applied to bees. In their treatment in this respect let the beginner experiment for himself, and scan everything closely; take nothing for granted till corroborated by his own observation, whether for or against the little pets. I hope no one will make the mistake of copying a blunder from me. I only wish that bee-keepers would adopt the directions given for treating bees kindly, and watch the result.

In regard to the charge of their being a nuisance, it does seem that much that is said is dictated by an unkind spirit, to say the least. It is nothing but justice to examine both sides. We want facts.

A. S. Fuller, in the New York Tribune, is credited with saying that "he is satisfied that in many localities these winged workers are a far greater nuisance than mosquitoes, or even sheep-killing dogs. Perhaps some grape growers may ask their neighbors to keep their bees at home, as they do the cattle, for there is certainly no difference in the moral or legal aspect of the two cases. Let every one keep as many bees as he or she likes, but if they do any damage to the neighbors' crops the owner should be held responsible."

The last sentence seems not very unreasonable, if we can only get at the real damage. I claim it is very small, if any. It is difficult to ascertain. The difference in the "aspect" of the two cases is at once apparent. When cattle trespass, it can be seen, proved, it is not difficult to substantiate facts. But with the bee, how is it? Mr. Fuller "is satisfied," and seems to think it proved. In court, witnesses must know; some are too easily satisfied. The prosecutor would lose his case if he had nothing stronger. To see what satisfies Mr. F. we may

follow him into the vineyard. He is examining his grapes, he finds a cluster of fair ones, with a hole through the upper side of some of them, and bees and hornets around most of them, if the day is warm enough, busily engaged sucking the juices. Here is proof that satisfies him that bees alone have spoiled his grapes. The same kind of proof would satisfy some, that when the larvæ of the flesh fly was found devouring the carcass of a putrid animal, that they were the cause of its death. The same kind of evidence has proved that the moth worm has destroyed bees, when they only completed the destruction that was inevitable from other causes. A negative can not often be proved. I can not say that bees never puncture grapes; but I can say that I am satisfied that they never do any more than the flesh fly kills the animal. I have 4 or 500 grape vines and other small fruits, as well as apples and pears, and a large apiary, all in one locality. I have no interest to bias me, and ought to be able to judge somewhat understandingly. If I was called to testify in such case, it would be of what I know. I have seen bees on grapes; sometimes two or three on one, when they had been punctured so as to expose the juices. I have watched them long and patiently, to see them attack sound fruit, and never yet saw one do it—and no man of veracity ever told me that he had. The last season I had several barrels of delicious pears. I have seen bees on them—a dozen on one—and other bees endeavoring to get a chance at the orifice already made; and this while the sound ones of the same variety remained on the trees untouched. But when one had fallen, and was bruised sufficiently to expose the juice, it was attacked without hesitation. The same with apples; as long as sound on the tree they were not molested; but when taken to the cider-mill—only a short distance from my bees—and ground into pomace, tens of thousands would sacrifice their lives in their eagerness for the juice.

Relative to grapes I would say that I have visited the vineyard early, long before a bee was stirring. Found grapes—three or four in a cluster sometimes—particularly Concord—with a narrow strip of skin peeled off—loose strip often left—the pulp fresh, and no juice gone, which would not have been the case if bees had been the cause. Yet the grape was as effectually spoiled for market as if the bees had sucked it dry. What did it do? If I make it clear that the bees did not, am I under any more obligation to trace it to the starting point than Mr. F. or any other man? Will Mr. F. watch the Robins a little closer, and see if some of the strange ones, on their way south, may not be tempted to peck through the skin of the grape as well as pear—perhaps only to find the grape unpalatable.—See "New trick of the Robin," page 103, last month's *Agriculturist*.—I want old bee-keepers as well as beginners, and those interested to look at these things, not to substantiate a preconceived opinion, but to get the facts, even if some notions are upset that appear to be well founded.

Feeling much regard for Mr. Fuller for what he has done in horticulture I should be pleased, if on investigation it should appear that what is attributed to him he has not said.

Many of our feathered songsters have been accused of destroying the farmer's crops by the unreflective, and have been slain by thousands, but investigation gave them credit for actually assisting the farmer, and a few have thought best to let them live and take the good they do to balance the evil. Will Mr. Fuller, or some one equally capable, just tell us if the bee does not help the farmer somewhat in aiding the fertilization of the fruit flowers, thus balancing some of the possible evils, and then, if he can establish the actual damage over the balancing benefits, the bee-keeper can choose between "taking care of his bees," or paying the amount assessed in dollars and cents. As the damage complained of never takes place in a season of honey, they can be kept from trespassing more cheaply than cattle.

Other complaints of damage have appeared, which I would like to examine some time, and see how close a man can come to proving a thing and not do it.

John Johnston.

The readers of the *American Agriculturist* will be pleased to see the portrait of that distinguished farmer, John Johnston, given on the first page of this number. The portrait is given without his knowledge, and we dared not ask him for any facts in regard to his life, for fear he might suspect our purpose. We must, therefore, confine our remarks to a few of the more prominent events of his career.

John Johnston was born in New-Galloway, Scotland, in the year 1791. Many of his early days—and nights also—were spent on the hills

tending his grandfather's flocks of sheep. "Whatever I know of farming," he once said to us, "I learned from my grandfather." And right nobly have these early lessons been reduced to practice throughout a long and eminently successful life. "Verily all the airth needs draining," was a remark of Grandfather Johnston in Scotland. We shall see how well the boy Johnston, some years later, in far distant America, applied the idea to practice on his recently purchased farm.

Mr. Johnston married in 1818, and came to this country in the spring of 1821. After looking about for a few months he selected and purchased a farm lying on the eastern shore of Seneca Lake, near Geneva, N. Y. The land lies on a high ridge, and a casual observer would not be likely to suspect that it needed draining. The soil is a rich, calcareous clay, but when he purchased was in a badly run-down condition. Mr. Johnston being poor had to run more or less in debt, and his neighbors predicted that he would soon be sold out. Here he commenced his life-work, and here he has lived for 52 years. "I have always been an anxious man," he once said to us, but his anxiety was of that kind which stimulated industry and quickened thought. He believed in hard work and good farming. He had his trials and discouragements like the rest of us, but when he stumbled he came up ahead. He had unbounded faith in himself. He was not afraid to run in debt for land or for the capital necessary to improve it. He did not believe in small farms. "I do not know how to manage a small farm," he once said to us. He was quite as capable of managing his farm of three or four hundred acres as one of fifty acres.

Mr. Johnston's leading crop has always been wheat. Everything else was secondary to this. But he has also made a good deal of money by fattening sheep and cattle in winter. "But," said he, "I never made anything by farming until I commenced to drain."

He commenced draining his land in 1835. He sent to Scotland for a pattern and got tiles made by hand. His neighbor, the lamented John Delafield, imported a machine for making tiles in 1848, and from that time Mr. Johnston laid tiles as rapidly as he could get the work done by the ordinary labor of the farm. "It cost me more," he once said to us, "than it would to have had the whole work done as Mr. Swan did it, at once, but I had to get the money from the crop on the drained field to pay for draining the second field." In fact, his draining paid for itself as it progressed. The extra yield of one crop of wheat frequently paid the whole expense of the draining; and in no instance did he fail to get all his money back in two crops. In 1851 he had laid sixteen miles of tile drain on his farm. In 1856, when we visited him again, he had between fifty-one and fifty-two miles of tile drains, and we believe nearly every tile had been laid with his own hands.

Underdraining was a new thing in those days. Some of the neighbors said, "John Johnston is gone crazy—he is burying *crookery* in the ground." But mark the result. When the so-called weevil, or midge, proved so destructive to the wheat of Western New York that nearly all the farmers thought they should have to abandon the crop; when on many farms the wheat would not yield ten bushels to the acre, we visited John Johnston (in 1856) and found he had sixty-two acres of wheat that almost bid defiance to the midge. He had that year twenty-five acres of Soule's wheat that averaged

83½ bushels per acre; and his red wheat was as stout as it could grow. In 1859 his crop of white wheat averaged over 41 bushels to the acre.

It would be an error, however, to attribute Mr. Johnston's success solely to underdraining. He has cultivated his land very thoroughly. He is a strenuous advocate for summer-fallows—plowing three, and occasionally four, times. He has made his land dry, clean, mellow, and rich. He grew great crops of clover for many years, dressing the fields liberally with plaster. After his land became rich he has grown timothy grass as well as clover, as he thinks he gets more and better hay. He has used lime with great benefit on his wheat. He has also used salt—a barrel per acre on his wheat—with remarkable results; he has sometimes used as much as seventy-five barrels of it in a year. He has also used more or less Peruvian guano. But in all his operations he has never lost sight of the manure heap in his barn yard. He has raised great crops of clover and fed it out on the farm. He does not plow it under. His corn, stalks, and straw, are all consumed on the farm, and for many years he bought tons and tons of oil-cake to feed with his straw. In this way he made great quantities of manure—and it was rich manure, not rotten straw. He piles his manure in the spring and uses it as a top-dressing on grass in the summer or autumn, the land being plowed up the next spring for corn.

Personally, John Johnston is tall and fine-looking, every inch a gentleman. He is temperate in all things. He neither drinks spirituous liquors nor uses tobacco in any form. A stranger seeing him in a select company would pick him out as a gentleman of the old school—perhaps a distinguished general or statesman. He would hardly suppose he was "nothing but a farmer"—that he had spent his life in a quiet farm-house; that he had followed the plow, dressed hundreds of sheep for foot-rot, and laid fifty miles of underdraining tiles with his own hands. And the stranger would be right. John Johnston is a distinguished man. He has led a most useful and honorable life. He has made money—and made it solely by farming, not by speculation. He has lived comfortably and brought up and educated a large family. His children, grandchildren, and great-grandchildren, delight to visit the old quiet home on the borders of the deep and beautiful lake. Here, too, many of our foremost farmers like to go, as on a pilgrimage, to pay their respects to the man whom they have learned to honor. Here, respected and loved by all who know him, may his life long be spared, as a grand specimen of an industrious, intelligent, true, and independent American farmer.

Ogden Farm Papers.—No. 50.

Since making up the statement of dairy results in the preceding article of this series, I have noticed a report on the same subject published by the Buffalo Live Stock Journal—to the effect that Mr. Cooper, of Wyoming Co., made an average per cow, in a herd of thirteen, of 4,928 lbs. (2,292 quarts) of milk. The net money proceeds averaged \$66.63 per cow—being 1³⁴/₁₀₀ cents per pound, or 2⁹⁰/₁₀₀ cents per quart. In addition to pasture he fed green oats and corn fodder. Mr. A. Tefft, of Chautauqua Co., with a herd of twelve cows, made an average of 7,245 lbs. (3,370 quarts) of milk. O. Brunson, Chautauqua, with seventeen cows, averaged 6,989 lbs. (3,250 quarts). A. P. Brunson, with twenty-four cows, averaged 6,163 lbs.

(2,866 quarts). At Mr. Cooper's price (2⁰⁰/₁₀₀ cents per quart) the others received, respectively, \$97.73, \$94.25, and \$83.11 per cow per year.

Per contra, the Country Gentleman published last autumn a series of very carefully prepared articles by E. Lewis Sturtevant, analysing the reports of over 300 butter and cheese factories in the State of New York, and of dairy farms to which the premiums of the New York State Agricultural Society have been awarded. In these articles it is demonstrated that:

1. "The average yield of the average cow of New York State can not exceed annually 1,350 quarts."

2. "The average yield of *superior dairies* will not exceed 1,800 quarts."

He concludes "that the annual yield of the native cow *in dairy regions* of America can be fairly estimated at 1,800 quarts a year."

Taking 2⁰⁰/₁₀₀ cents as the average price, we have \$39.15 for the average of New York State; \$52.20 for the average of the best dairies in that State; and \$37.70 as the average of the dairy regions of America.

Here is a difference between the average of the four cases reported in Chautauqua and Wyoming and the average of American dairies—\$37.70 per cow on one side and \$85.43 per cow on the other. The average of the good herd is *one hundred and twenty-seven per cent* better than the average of the whole.

The question naturally arises whether the better dairies cost 127 per cent more than the average, or whether any considerable part of this increase is profit. Remember that we are not considering the average cow of the whole country, including all the poor animals kept on poor forage by poor people, but the average in what are sufficiently large herds to be considered as dairies, and where the sale of dairy products is an important item of the farmer's business; this being, presumably, much above the average of all, if we include the poorer cows kept by the poorer people, and in those regions, especially in some parts of the South, where there is nothing worthy of the name of dairying carried on.

We shall certainly be within the mark if we say that the keep of a common cow generally requires, on average farms, for pasture and hay the year through, not less than six acres of land; so that the product of \$37.70 gives a gross return of \$6.28 per acre. Out of this must come interest, insurance, and depreciation on one-sixth of the value of the cow, the same on her proportion of the farm buildings and implements needed for the business of dairying, the maintenance of wagons and horses needed for marketing, and all the labor of hay-making, driving to and from pasture, feeding, watering, milking, and the care of utensils. The income from twelve cows would be \$452.40. How much of this would be left for clear profit after all the foregoing deductions were made, and after paying interest on the value of 72 acres of land, any farmer can figure out for himself. If he gets more than a meager subsistence in return for his slavish work he will probably find on examination that it comes from some other item than the dairy.

It may seem anomalous, but if it is fair to allow six acres per cow in an average dairy, it is fair to allow four acres per cow in the superior dairy. In the first case I allow three acres for pasture and three acres for hay (2½ tons); in the second I allow two acres for pasture, 1½ acre for hay (two tons), and half an

acre for corn (grain, stalks, and green fodder) and a few roots. The secret of this difference is that better cows imply better farmers, and better farmers imply better land, for improvement in farming is literally a "double back-action" affair. Good feeding reacts on the more copiously manured land, which responds with better supplies of food, and both of these stimulate the farmer to the general bettering of his farm and furnish him the means for it. A good farm in the hands of the right sort of man is like a swelling river in a limited channel: it is always growing out of its bounds, getting bigger and bigger, and demanding more and more capacity for its rising tide—just as a poor farm in the hands of a dullard is like a stagnant pool, which the rains of heaven are barely able to keep from drying up altogether.

Seventy-two acres of well farmed land of the same *original* character as that considered above will carry eighteen cows as readily as that would carry twelve cows. These, at an average income of \$85.43, will yield a gross return of \$21.36 per acre, instead of \$6.28, and for the 72 acres \$1,537.74 instead of \$452.40. The interest on the cost of the land will be the same; on stock, buildings, and implements more, of course, but we may leave an ample allowance for this without nearly equalizing the incomes. The labor will not be very much more except for milking, for the labor of cultivating the half acre will not greatly exceed the cost of harvesting and renewing the extra amount of mowing land of the poorer farm, and it will be more than compensated for by the extra profit from the incidental items of the better farming.

Such estimates as the foregoing are not sufficiently well grounded to be made minute and exact; but no one competent to form an opinion would hesitate to say that after all expenses are paid the inferior of the foregoing examples would result in a tight squeeze to make both ends meet, while the other would show a handsome and yearly increasing profit.

In the better cases cited (Chautauqua and Wyoming) the cows were only well selected natives, and the result might be materially increased by the use of thorough-bred or even grade Ayshire or Dutch cows. In Mr. Tefft's case the result was largely due to the fact that he feeds his skimmed milk to his cows, mixing ground feed with it (bran and corn and oats). In reply to my question on the subject, he says that this has long been his practice, and that the whole product of skimmed milk may be fed back to the cows yielding it, with excellent results in product and in health. Having had no abortions in his herd, he ascribes his immunity (as is usual) to his manner of treatment.

I have previously referred to the subject of coloring butter, and during the past five years have experimented with nearly every recipe that has come to my notice. I have now settled on a system which is so satisfactory—after nearly three winters' application of it in the coloring of over 3,000 lbs. of butter—that it is worth while to state it somewhat in detail. The question whether butter ought to be colored at all is one that may be left to the judgment of the maker. It is quite certain that butter of a good color sells for a better price than that which is as white as winter butter almost invariably is. I do not find that my customers object to artificial coloring, and I am sure they would criticize an uncolored article. No one objects to coloring with carrot juice,

which is unreliable in the matter of taste, and grows more and more so as the spring approaches; but annatto is sometimes looked upon as a "drug," and many hesitate to use it on this account. The annatto plant, which grows in the tropics, bears a prickly pod about the size of a horse-chestnut. In this are many seeds, of about the size and shape of kernels of buckwheat, which are imbedded in a reddish pulp. When the pod ripens the pulp dries and adheres to the seeds. This pulp, removed from the seeds, is the annatto of commerce. The common means of preparation is by steeping in water and boiling to a paste and then drying; this is "basket annatto." Recently, Mr. G. de Cordova has developed a process for removing the pulp from the seeds by washing in cold water, separating the coloring matter from the liquid and drying it without the application of heat, and then pulverizing it, securing the coloring principle pure and of full strength. This is called "annattoine," and is the substance that we use, the form being not different from that in which it exists in the native pulp, which is used by the people of Brazil as a flavoring matter in cooking much as we use salt, and which is as much an article of food and as little a "drug" as is carrot juice. Annattoine is a natural vegetable product, artificially separated from its natural combination without being changed in character, and may be regarded as wholesome and even nutritious. It may be used in several ways. That which we have adopted (and which costs about 10 cents per 100 lbs. butter) is according to the recipe of Messrs. Whitman and Burrell, of Little Falls, N. Y., who are large dealers in the material. I first got their recipe from Willard's Dairy Husbandry, and afterwards in an improved form from themselves. It is as follows: 1. Dissolve one pound of the best potash and one half pound sal-soda in ten quarts water, stirring occasionally, and allowing it to stand until well dissolved and until the impurities have all settled to the bottom of the vessel. Pour off all the clear liquor possible, let it settle again and pour off more, and repeat until only the sediment remains. 2. Dissolve one pound annattoine in eight quarts clear cold water, and let it stand in a cool place from one to two days until perfectly dissolved, stirring occasionally and thoroughly. This mixture will ferment if too warm. 3. Mix the two liquids together and let the compound stand until the annattoine is perfectly united with the alkali and the liquid becomes clear, stirring occasionally. 4. Store in earthen jars, or if in glass keep in a dark place. 5. Immediately before churning shake the bottle and put into the cream a large table-spoonful of the liquid for each gallon of cream, and stir it at once. More or less may be used, according to the depth of color desired—more for butter to be sold fresh than for that which is to be salted down, as the tint becomes stronger with time.

I have received a long letter which I condense as follows. (It is evidently written under the erroneous impression that we—O. F.—own the *American Agriculturist*. I wish we did.) 1. Why have you discontinued the use of cooked food for neat stock? 2. How can I keep my stable from freezing? It is made of matched rough boards, but there are some cracks. Shall I cover with paper, then with clapboards, and board up inside the joists and fill in with sawdust? Would it be desirable to make the stable warm, and what would it cost? 3. Would paper be better or cheaper than plas-

tering to keep frost out of a cellar? 4. Is not the white or light color of Jerseys and other cattle caused by long-continued delicate keeping and sheltering? 5. Why do you keep a farm? To enable you to run your printing business? How much have you made by tilling the earth? One of my late neighbors left property valued at \$75,000, accumulated by farming and perhaps by the enhanced value of real estate. He would have nothing to do with

than that of Lombardy, where the cattle are uniformly without white. On the other hand, the wild Chillingham cattle of England (now domesticated) are white, and so are Polar bears. 5. Perhaps for the fun of the thing; perhaps to have something to write about; perhaps with a view to money making—and probably with an eye to all three. The farm has no connection with the paper, except as a subject. The amount of our income from farming has

attachment which may be fitted to any plow whatever, by the use of which a great improvement may be made in plowing either sod or stubble land. The attachment, with its method of working, is shown in the accompanying engravings. It consists of a blade of steel similar to a round-pointed shovel attached by means of a shank to a jointed and curved arm. The arm is bolted to the plow by the bolts which fasten the mold-board to the handle. The attach-

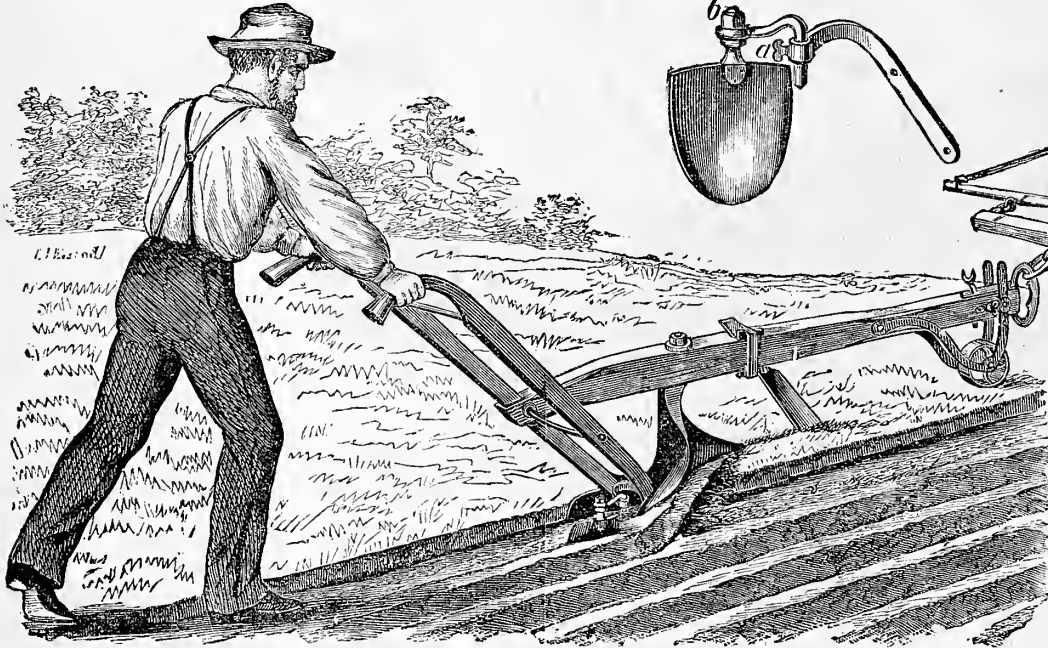

Fig. 1.—DONNELLY'S ATTACHMENT TO PLOWS.

agricultural societies or papers. 6. For twenty years I have never lost a cow or calf by sickness and death, or had a single hour's sickness among them. Two years ago I followed your advice, and milked my best cow up to the time of calving. She became so reduced that she could not hold her supremacy, and lost her calf. I think a cow will give as much milk in a year or in a lifetime with two months or more rest as with less. 7. I think I could so take care of any herd as to prevent abortion or any other kind of sickness. If the system becomes reduced the animal is sure to suffer from disease. We should keep our animals "happy."

To which I reply: 1. We have suspended the cooking of food only because we had no corn fodder to speak of (we did steam so long as that lasted), and because our early cut hay is so good steaming would probably not help it much. 2. It will suffice probably to clapboard the outside of the barn (without paper) and to board up on the inside with matched boards (without filling with sawdust) unless the stable is very large for the stock kept. Bank around the base-board and foundation with leaves, or else plaster so well about and over the under pinning that no wind can blow in. It is very desirable to make the stable warm and to allow sufficient ventilation without having anything of the nature of draughts in the air of the stable. Any builder in your neighborhood can tell you what it will cost. 3. Plastering might cost a little more than paper, but it would be much better, and you can better stop the leaks about the sill timbers. 4. It is hard to say what is the origin of the white in cattle, but there seems no reason for attributing it to delicate keep. Jerseys are not delicately kept at home. They are tethered out nearly all winter, and endure much rain and raw wind. The climate is much softer than with us, but much colder

not been publicly stated. Your neighbor's case may be a good example of the value of neglecting the usual means for acquiring knowledge of one's business—or it may not. How much of his property was due to "the enhanced value of real estate," and how much to interest on money that would have been better invested in giving himself and his family a better education and a better life, would have much to do with the matter. 6. You have been careful, skillful, and lucky, and are to be congratulated. Few farmers have had such success, and those who have are more often they who have seven cows than they who have more. I do not now remember what I wrote two years ago about milking up to the time of calving, except that I favored it; but my subsequent experience has led me to think that it is best to allow cows to go dry one month when possible (with Jerseys it is not always possible). But I think this ample, and the harder work it is to dry them off the better I like them. 7. I think you would find yourself mistaken. Abortion (as an epidemic) is not preventible by any means now known. It comes like a thief in the night, and attacks old and young, strong and weak alike, and without the least apparent cause. Fortunately, it goes as mysteriously as it came, and it has gone from Ogden Farm. You hit the nail on the very head when you say that cows should be kept "happy." If there is a secret of success it lies in that.

An Improvement in Plows.

We have recently had an opportunity of testing an improvement in plows, or rather an

ment is shown in detail at the right hand upper corner of figure 1. Beneath, it is shown in operation. Being attached to the right hand plow handle, it is set into the proper position for work by means of the thumb-screw and nut, shown at *a* and *b*. When so set, and the plow is put in motion, the attachment acts as a sort of scraper, which scoops out of the newly-turned furrow slice, a groove, the earth from which is scattered upon the sole of the furrow. This is shown at *c* in figure 2, where the earth removed from the furrow slice, leaving a groove at the right of the letter *c*, is seen scattered at the left in the furrow. The effect of this is to make a mellow bed of earth, upon which the inverted sod or earth falls, leaving no vacant spaces into which seed may fall and be lost, and causing the sod, by close contact with this loose soil, to rot perfectly and not throw up a new growth of grass in each furrow, as it often does with our ordinary plowing. The surface of the plowed soil is therefore left in furrows and ridges, closely packed with mellow earth in the bottom of each furrow.

The advantages of using this improvement are many. In planting potatoes the seed may be dropped in the furrow immediately after the plow, upon the mellow soil left by the scraper. The next furrow falls upon the seed, the sod and earth covering it. If the ground is manured the manure falls upon the seed in the best possible position. After the field is plowed and planted a stroke with the back of a harrow, given after a few days, levels the surface, killing the weeds which may have germinated, and covering the seed to a depth of about three inches. If oats are to be sown upon a manured stubble, the seed, as the soil is inverted, falls upon the mellowed earth in the furrow and remains covered with the manure. If fall wheat is to be plowed in the same thing occurs, but the surface is left in a succession of ridges which offer the greatest protection to the plants against winter-killing and heaving out by the frost. In both these cases a great saving of labor is made, because one plowing finishes the whole work and no harrowing is needed.

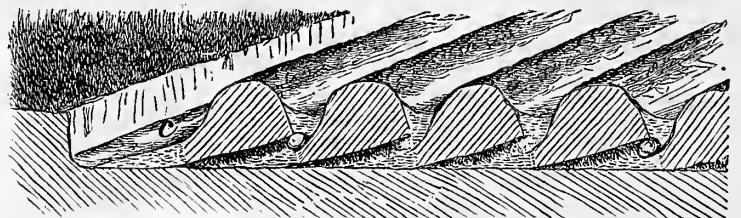

Fig. 2.—MANNER OF OPERATION OF PLOW ATTACHMENT.

Fodder corn may be planted in the same manner as potatoes by dropping the seed in the furrow. Many other advantages will be obvious to the plowman who realizes the necessity of having the seed and soil come together in the best possible manner. The implement is known as "Donnelly's attachment" to the plow.

Oxford-Down Sheep.

The engraving here given is a copy of a photograph from life of an Oxford-Down ram. He is a three shearling, bred by Mr. Charles Howard, of Bedford, England, and was exhibited at two of the chief agricultural fairs in England, at both of which he was highly commended. The flock to which he belongs has taken no less than 72 prizes at different fairs since 1849, and being selected as a type of such an excellent flock, this ram may be accepted as a model of what this breed of sheep should be. The Oxfordshire Downs date from 1833. They sprang from a cross of the Hampshire and the South-Down ewes with Cotswold rams. By judicious selection a satisfactory result has been attained in producing a breed excelling in the desirable points of producing a good fleece of valuable wool, superior quality of mutton, hardiness of constitution, and uniformity of character—all points of the greatest value in a breed of sheep. From the flock of Mr. Howard sheep have been sent to Australia, Portugal, Spain, France, Germany, Austria, Russia, Sweden, Holland, and Belgium. Each year, in July, the rams are sold at public sale, and the price has steadily advanced since 1865, when these auction sales commenced.

Spring Management of Lambs.

The critical time with young animals is at their weaning. The change of food is so complete that if it is suddenly made mischief can not fail being done. This is particularly true as to lambs, and upon the proper treatment before weaning them greatly depends their future constitution; if indeed they escape with life the many dangers incident to lambhood. As a general rule it is best to begin weaning a lamb as soon as it is a month old, or as soon as it can be tempted to eat. Before the ewes are turned out to pasture a separate inclosure should be made, to which the lambs alone can gain access, and in which some tempting and nutritious food is provided. This may be made adjoining the yard where the ewes are fed. There a small trough, several feet long, resting upon the ground, should be placed, in which a few handfuls of bran or oatmeal sweetened with sugar should be scattered. This has been our own practice

in hastening early lambs for market, and a two weeks' old lamb would learn to nibble its share along with the rest. Afterwards, when the ewes come to be turned into the field, the practice should not be discontinued, but, if possible, some arrangement should

the gate consists of an upright roller, which, as the lamb squeezes through, turns and prevents the animal from injuring itself or from tearing its wool. The gates are pivoted, as before stated, at the middle of the upper and lower bars, but on the outside of the fence. Thus when

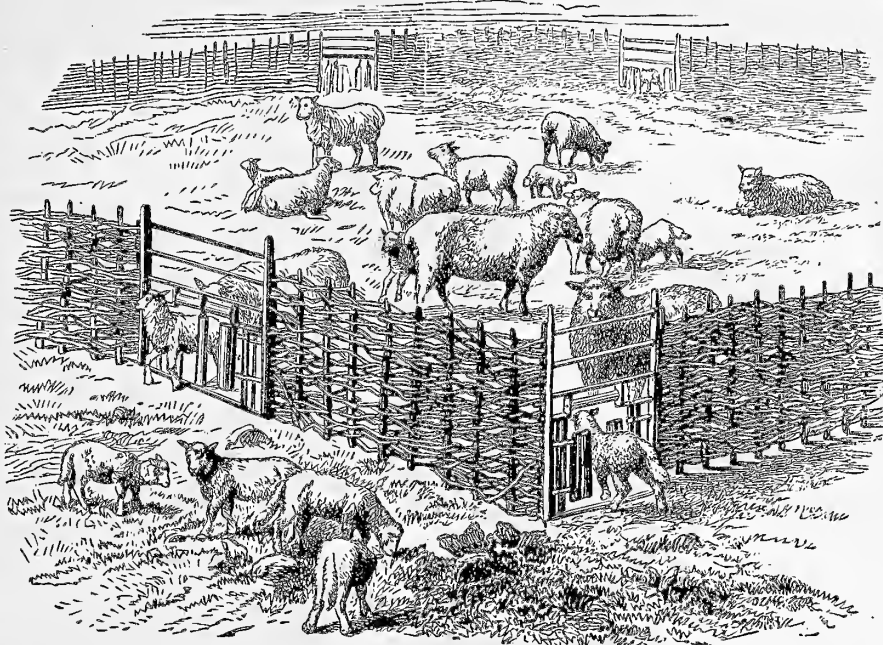

AN ENGLISH LAMB CREEP.

be made by which the lambs may have the run of a good piece of grass or clover along-side of the field in which the ewes pasture. We have generally arranged this by making small gaps in the fence, through which the lambs may creep when they are disposed. These gaps they soon discover and make use of, very early learning the natural trick of trespassing where they think they ought not to go. The best method of making a "creep" for the lambs, either in the yard or the field, that we have seen, is one shown in the accompanying engraving. It may be attached to any fence or

light stakes into the ground and wattling light brush-wood amongst them. The stakes may be driven about four to six feet apart and the fence made four and a half feet high. A very useful portable fence for sheep may be made in this manner by weaving it in separate lengths of about 10 feet. Each length should be fastened to the next one by withes, and to a stake driven into the ground at the point of junction; another stake should be driven at the middle of each hurdle to strengthen the fence. If made of stuff from one half to one inch thick, a very substantial

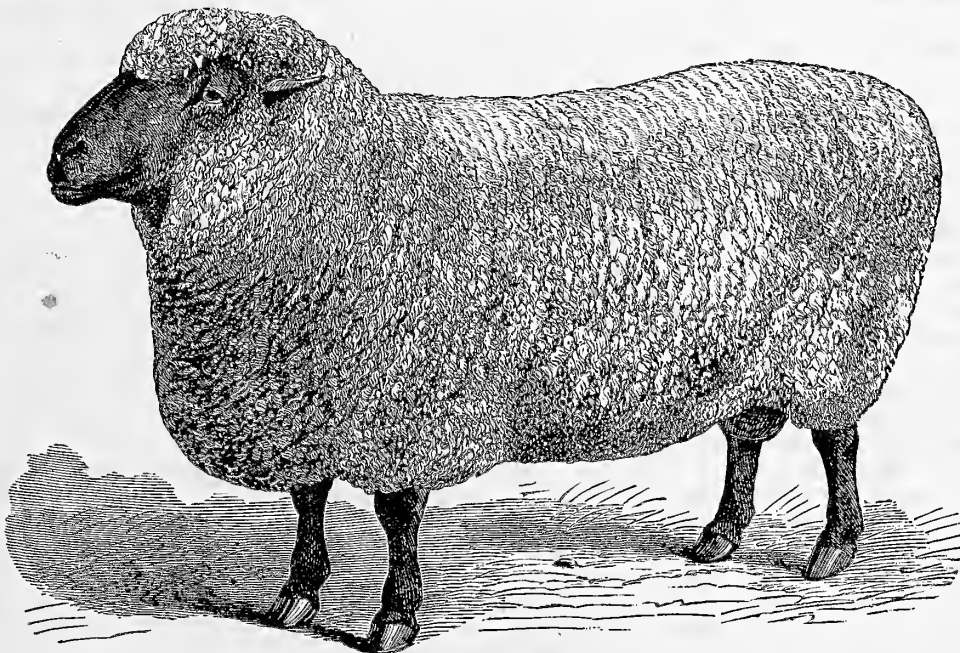

OXFORD-DOWN RAM.

hurdle. It consists of a small double gate, or two single half gates, pivoted at the middle of the upper and lower bars to an opening made in the fence, in such a way as to afford room for a lamb to pass outwards without opening the gates. The inner extremity of each half of

but yet light hurdle may be had, which will last many years with care, and which, where the material is readily procured, will cost nothing but the labor, and as this can be well spared at some seasons of the year, the cost will be practically nothing. We have seen such hurdles made of the low birch and alder brush, which abound in swampy places, that answered every purpose of a costly fence. To make the hurdles of such timber the stems of the brush should be cut into lengths of four feet and a half or five feet, and closely trimmed of all the branches. A scantling the length of the hurdle required is procured and holes are bored three or four feet apart. The stakes or stems are put into the holes standing upright, and the branches can then be woven between them very easily. The small twigs should be woven in along with the larger ones.

Walks and Talks on the Farm.—No. 124.

"R. F. W.," of Chester Co., Pa., writes: "A year ago last spring I sowed oats and peas, and raised about half as many more as I sowed. Last spring I tried it again, and the peas were an entire failure. We don't care about trying them any more."

Probably the conditions were not favorable. The land must be very rich, dry, and mellow, and the crop sown early. There is, of course, nothing to be gained by sowing two crops on the same land if the land is not rich enough to produce one crop. If you think the land too rich for oats, sow peas and oats together and you will stand a chance of getting a great crop. This is all there is to it.

"We also tried," continues Mr. W., "white mustard and rape. Plowed the ground in the spring and again in July. Sowed both mustard and rape July 21st. The field is rather poor—too poor for a good crop of corn. The mustard attained a growth of three to four feet. The rape made considerable growth but did not bloom. [It ought not.] Both were pastured with sheep, which eat the rape to the ground. The mustard was not eaten so well. But it was too old when turned into."

The mustard should have been fed off in September and October. The rape should have been reserved for feeding late in the fall and winter. Frost will kill the mustard, but does not hurt the rape.

"We have an oat-stubble field," continues Mr. W., "which we have been thinking of sowing to mustard in April or May; then pasturing the crop with sheep and sowing the land to wheat in the fall. Will it pay?"

The difficulty will be in its ripening up so fast that it can not be eaten off before it forms seed. It ought to be sown at different times, say a week or ten days apart. But in this case it will be necessary to have hurdles or some kind of portable fence to prevent the sheep from running over the whole field at once.

"It is the prevailing opinion in this section," says Mr. W., "that 40 or 50 ewes are as many as can be kept together to advantage. We undertook to prove the contrary, and last fall increased our flock to 113, of which five died early in the season, and of late seven have lost their lambs by premature birth. Can you tell the cause or suggest a remedy? The sheep have been fed corn, corn fodder, and clover hay, and have been kept in the yard except that they go out to water every day."

Perhaps they were kept too closely confined in the yard, or crowded each other in rushing through the door or gate when watered or fed, or perhaps the corn fodder or hay was moldy, or you feed too much salt at a time. Mr. W. does not say what breed of sheep he keeps. There is a general impression in this country that the long-wooled and other English breeds of sheep can not be kept in large flocks. The improved breeds of sheep, which mature early and fatten rapidly, will not stand neglect as well as the slow-maturing breeds. Texan cattle will stand long walks and short commons better than a Shorthorn.

We have yet a good deal to learn in regard to the management of long-wooled sheep. We can adopt English practices only in part. We must think and plan for ourselves. We must study our climate and the demands of the market. We can raise long-wooled sheep just as well as they can in Canada. We can produce all the long wool that our manufacturers re-

quire. We can supply our markets with good mutton. But how best to do all this is an open question. It is far from settled. I think it will be done by grading up our common sheep.

"C. W. H.," who has a large farm near Columbus, Ohio, asks me several questions. He has an apple orchard, in which the trees are fifteen years old. They stand in a blue-grass sod, very stiff, not having been pastured or mown for several years. "The canker-worm," he says, "is very bad in this section, and has been for several years. My orchard escaped until last season, when it had a few on it. Had I better plow the sod or had I better turn the hogs in it?"

Do both. Plow it very shallow early in the spring or late in the fall. The sod will rot and enrich the trees. The canker-worm can be held in check by scraping off all the rough bark and then taking strips of brown paper three or four inches wide and pasting them tight round the trunk of the tree. Then smear these bands with tar or printer's ink and see that the tar or ink is kept constantly fresh and sticky. Plowing the orchard and turning in the hogs will not kill the canker-worms. I would turn in the hogs to eat up the fallen fruit, and thus check the spread of the codling-moth which produces the worm in the fruit.

The codling-moth is becoming a terrible pest. I hold them so far in check in my orchard by pasturing it with sheep. In the garden I have over fifty varieties of dwarf apples. They are very fine, thrifty trees, and bear well; but the codling-moth leaves me very little perfect fruit. I have also on one side of the garden seven Northern Spy trees set out at the same time as my main orchard. The latter last season produced from two to five barrels to a tree. All the good apples I saved last year from the seven trees in the garden were put in one barrel. The rest were wormy. My old orchard, which has been set out forty years or more, has always been used as a hog pasture, and the apples are entirely free from the codling-moth.

The Judge has an old orchard of about two hundred trees, from which in four years he got more money than he paid for his whole farm of 75 acres. Three years ago, thinking to improve it still more, he plowed it up the last of May or first of June and sowed it to peas. He thinks the plowing checked the growth and productiveness of the trees. I think the orchard will get over it in a year or two; but it seems reasonable to suppose that cutting off the roots while the trees are in full leaf must be a serious check to them. The plowing should either be done so shallow as not to cut the roots, or done while the trees are comparatively dormant—in the fall or early spring.

From what the editor of the *Agriculturist* said about the barrel of Northern Spies I sent him I was afraid we had not pressed them tight enough in the barrels. And so the last time I was in New York I went to the firm who bought my crop. They did not know me. One of the young men asked me if I wanted to buy some apples. I told him I would like to look at some Northern Spies. He opened a barrel, and asked me \$4.50 for it. "Have you nothing better?" I asked, and he opened another barrel. "These are small," I said. "I want to see the best barrel you have. These are not as good as those I am now eating." He called another young man, and they whispered together a moment. "Not that," said the new comer, "open that barrel," pointing to a barrel that

had my name on it. On opening the barrel it proved to be in perfect condition—just as handsome as when put up in the orchard. "How much do you want for these?" I asked. "Six dollars," he replied. "Six dollars!" I exclaimed angrily, "why, you only ask \$4.50 for the others; why do you ask six for these?" "These," said he, "are the choicest Northern Spies ever put in a barrel. They were grown"—and here he looked at the head of the barrel to refresh his memory—"they were grown by Harris, of Rochester."

"Did you tell him who you were?" asked the Deacon.

No. I told him I would call again—and I will the next time I am in New York, as I want to learn all I can as to the best method of packing and handling the fruit.

In the market report of the last number of the "Chamber of Agriculture Journal and Farmers' Chronicle," published in London, it says: "Barley: all qualities have been very strong everywhere. Some 10,000 quarters [80,000 bushels] have been bought in London this week for shipment to America, consisting partly of French and partly of Danubian. It is not known whether this demand from America will continue." Our brewers and maltsters have themselves principally to blame for the present high price of barley. We can raise in this country all the barley that is required, provided we could be sure of fair prices. But the maltsters are as selfish and short-sighted as other people. When they get control of the market they force prices far below the cost of production, and the farmers stop raising barley. In 1850, I raised 30 acres of barley and sold it in Rochester for 37½ cents per bushel. In 1852 it was worth 70 cents. Since then there has been a greater advance in the average price of barley than in wheat, oats, and corn. But the fluctuations in prices have been very discouraging. I find in looking over the New York market reports in the *Agriculturist* that the highest quotation for barley in December of the different years is as follows:

1856, \$1.30 per bushel; 1857, 80c.; 1858, 92½c.; 1859, 88c.; 1860, 82c.; 1861, 87½c.; 1862, \$1.45; 1863, \$1.55; 1864, \$2.00; 1865, \$1.15; 1866, \$1.20; 1867, \$1.90; 1868, \$2.30; 1869, \$1.30; 1870, \$1.12; 1871, \$1.25; 1872, \$1.16; 1873, \$1.80.

In 1870 I fed out to my sheep and pigs 800 bushels of barley, which would now sell for \$1,500 or \$2,000. And so we go. And so we shall continue to go.

"Well, what are you going to do about it?" asks the Deacon.

If you are a barley grower stick to it year after year. If not, do not rush into it when the price is high only to quit it in a year or two. The truth is, only the best farmers should try to grow barley. The crop is a profitable one if you average 40 bushels per acre, but to do this you require better land and better cultivation than one farmer in ten is likely to give it. Unless your land is just right you will make more money raising oats than barley.

"Or oats and peas," says the Deacon.

Yes; but I have made up my mind not to say anything more about oats and peas. I get letters by the dozen about this mixed crop, and so does the *Agriculturist*, some of which they answer themselves and some they send to me. Here is one just received from southern Ohio. The writer wants to raise them for cow feed. "Will they succeed?" he asks. I do not know.

If peas do well and if oats do well, the two sown together on rich land will be likely to give a good crop. The probabilities are that he will do better by growing corn or by growing oats alone. "Where can I get the seed?" I buy mine in Buffalo. The peas are brought from Canada, and can be bought at from \$1.25 to \$1.50 per bushel. "How much per acre?" Sow 1½ bushel of oats and 1½ bushel of peas, or 2½ bushels of oats and 1 bushel of peas. I sowed thicker than this last year, but I do not think there is much advantage in it. Sow as early as the land can be got into good condition. It is better to drill in the seed. See that the oats and peas are well mixed and that they do not separate in the hopper. I cut my crop with a Johnston reaper. Thrash with a machine. A good fanning-mill will blow out the oats from the peas so that they can be fed separately if desired. The straw makes excellent fodder for horses and sheep. The cows will eat it, but they will give more milk on well cured corn-stalks.

This same writer says: "I like 'Walks and Talks,' but there are some things that we Western folks can not put in practice. For instance, you say petroleum is cheap and plenty. We don't get it at all here except in the refined state."—I had just the same trouble here. The gentleman who some years ago patented the use of petroleum for preserving wood sent me a "farm right" as a present. And so I thought I would try it. I went to Rochester to get a barrel. But it was not to be found. The dealers in oils and paints evidently thought I was a verdant man from the country, and offered me "rock oil" that they kept for lubricating purposes, telling me that I should soon be tired of painting with such stuff. I had to come home without my petroleum, and it was several months before I succeeded in getting a barrel of the kind I wanted. Since then I have used a good many barrels of it, and have now no trouble in getting all I want. And it will be so with my friend in Ohio. I speak of using crude carbolic acid, and I buy it by the barrel; but I suppose there are thousands of readers of the *Agriculturist* who can not find it at the stores. But I ought not to be blamed for this. When there is a demand for it the dealers will keep a supply on hand.

"It is just as I told you, Deacon. We farmers are going to have better times."

"You would not say so," he replies, "if you knew how hard it is to collect money. I tell you, farmers are poor."

"I know that very well—I am a farmer myself. But look at the situation. Potatoes here on the farm \$1 per bushel; white wheat, \$2; butter, 40c. per pound—and anything but gilt-edged Jersey at that; hay \$25 per ton, and straw \$12; barley for seed, about whatever you like to ask for it. I suppose you could get \$2.40 per bushel of 48 lbs. for choice four-rowed for seed, which is \$100 per ton. I have raised 1½ ton per acre, and can do it again."

"Still, I tell you farmers are poor."

"I know it, Deacon; I am poor myself. But there is a good chance for good farmers who have got their land in good condition. There is no money in poor farming—never has been and never will be."

"G. W. C.," of Ashley, Ill., writes that many pigs are dying in that neighborhood. I have had no experience with such diseases. I think

if the so-called hog cholera should break out in my herd I should separate all that were sick and put them in a dry, warm pen and keep them as quiet as possible, and give them the most nutritious and stimulating food and drink I could procure. If I lived near a slaughter-house I would give them fresh blood. Or I would kill a few sheep or a steer and cut up the carcass into mince-meat and boil it for a few hours, and give the pigs some beef-tea or mutton broth mixed with cooked corn-meal or oat-meal gruel or any easily digested and nutritious food. A little whiskey might also be given to stimulate digestion.

Some people seem to think that the reason why we have so much hog cholera is owing to the introduction of improved breeds of pigs. I think it is precisely the other way. What do we mean by an improved breed of pigs? Usually we mean a breed that has fine bone and little offal. A breed that is very quiet and that will turn the food it eats into flesh and fat. It is a breed that will eat and digest a stomachful of rich food and assimilate it. As a rule, the weak spot in all high-bred pigs is that their digestive powers are not as good as their assimilating powers. They can assimilate more food than they can digest. On the other hand, our common, coarse, unimproved hogs can usually eat and digest more food than they can assimilate. They are accustomed to forage for themselves. They have plenty of exercise and comparatively little food. Now then, if you take such a breed of hogs and endeavor to push them forward rapidly with rich food, it is easy to see how their blood could be poisoned by the excess of material which the animal is not able to convert into flesh and fat.

"Your remedy, then," says the Deacon, "is not to feed so high."

Rather, my remedy would be to raise a better class of pigs. I would raise such pigs as would stand high feeding until they were fat enough to go to market, and then I would dispose of them without delay. If you take pigs that are not accustomed to mature before they are three or four years old, and endeavor to so feed and force them that they shall be fit for market at twelve months old or less, what can you expect but hog cholera? On the other hand, a breed that is accustomed, and has been for generations, to mature early can be pushed forward rapidly without injury. I should expect the best success from pigs raised from a large, healthy, common sow sired by a highly refined, thorough-bred boar of a breed distinguished for its gentleness, fineness of bone, little offal, early maturity, and fattening qualities. The mother would furnish the digestive powers and the sire the assimilating powers. These qualities combined with early maturity, fineness of bone, and high quality of meat would give you precisely what a good feeder wants.

Mr. C. also says: "I see some calculations in regard to corn grown by John Johnston. It is good; but we farmers in Egypt [southern Illinois] do not profess to be thorough tillers of the soil, and yet I raised 131 bushels of ears of corn per acre, weighing 40 lbs. per bushel. I counted one ear that had 894 grains. Variety, yellow flint. It ripens earlier than our white corn. The ground was broken and planted without harrowing. Rows four feet apart, and hills two feet in the rows and two stalks to a hill. Cultivated three times twice in a row."—I fancy Mr. C. is a far more "thorough tiller of the soil" than he pretends to be.

I have an idea that there were not many weeds in that crop of corn.

"W. H.," of Grey Co., Ontario, asks the relative value of oil-cake and peas for fattening cattle. I do not think there is much difference. If anything, the oil-cake, provided it is genuine linseed oil-cake, is the most nutritious. I do not know how it is in Canada, but here I fear there is a good deal of poor stuff sold for oil-cake meal. I think half pea and half corn meal is better for cattle than all peas or all corn. Oil-cake enough to keep the bowels in order is also very advantageous. Much more depends on management and judicious feeding than on the actual and exact quantity of nutriment in a food. The farmer who does not keep flax-seed or oil-cake on hand, for at least occasional use, does not live up to his privileges.

I little thought when the Deacon and I talked about Mr. Bliss's potato prizes that he would act on our suggestion and offer such liberal premiums for the largest yield per acre. I want the Deacon and the Judge and the Squire to see which can raise the largest crop of our common varieties, and I wish others would join in. I propose to plant Early Rose, Late Rose, and Red and White Peachblows. I raised all these in one field last year, and the Late Rose was very decidedly ahead. Perhaps it may not be so in all seasons. The Peerless is grown to some extent here, and yields large crops. So far it sells as well in market as any other kind, and as long as this is the case it is a profitable variety. I notice an article in one of my late English agricultural papers on the "New American Potatoes," in which it is said: "It is not probable that we shall ever beat the Americans in the matter of raising crops. Our tubers won't be so large, although we may get as many to a root. This will be no evil, but rather a gain. We shall get better quality in our medium-sized tubers than they get in their large ones, and they will not be so liable to disease, as it is a fact that wherever disease prevails the largest tubers are most affected." It is new to me that we raise larger crops of potatoes here than in England. And I think it can not be true. I supposed three or four hundred bushels per acre was not an uncommon crop in England. Here 125 bushels is a fair average. I presume the tubers are not as large in England owing to the fact that they plant in drills and much thicker than we do when we plant in hills. Here farmers seldom apply manure to potatoes, and that is the main reason why we do not raise as large crops per acre as they do in England. We want to study not only the varieties, but how to so manure and manage the land as to grow large crops without any deterioration in quality. It seems a shame that in this great and fertile country consumers should now have to pay \$1 a bushel for potatoes, and those by no means of extra quality. There is money to be made in raising potatoes.

How to Load a Horse-Power.

"B. K. A.," Lancaster Co., Pa., sends us two methods of loading a horse-power which are in use in his neighborhood. One is to procure two scantlings or planks framed together with cross-pieces. At one end of this frame is a roller eight inches in diameter with holes in it for pins, by which it is turned. The frame is twice as long as the power, and is hooked on to the hind axle or bolster of a wagon so that

it will tip like a cart body. The wagon with the frame is backed up to the horse-power to be loaded. A rope or chain is hooked to the power, and is wound up upon the roller, draw-

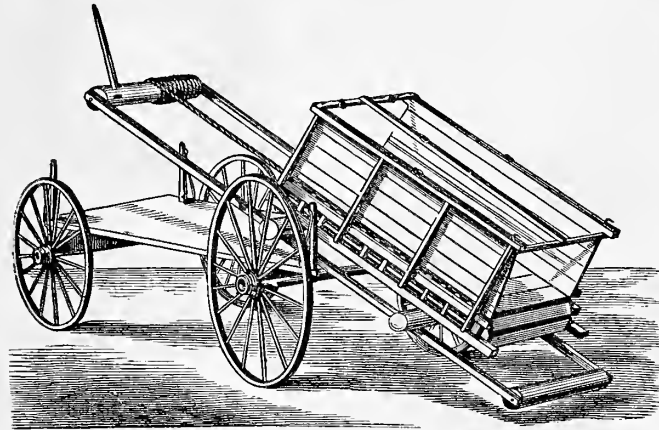

Fig. 1.—LOADING HORSE-POWER.

ing the horse-power, beneath which small rollers are placed, on to the wagon. When it is to be unloaded, the horse-power is run back until the end of the frame rests upon the

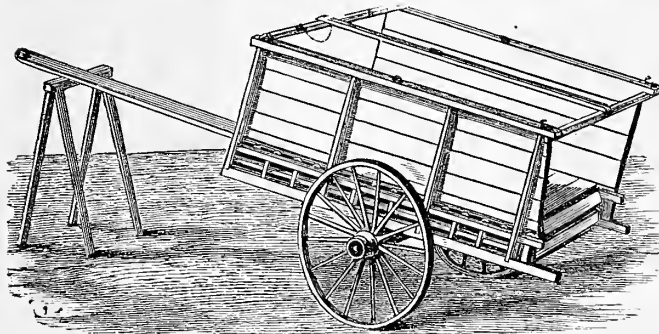

Fig. 2.—POWER READY FOR WORK.

ground, when it is in the right position to be used. Fig. 1 shows this method.

The other method is to mount and fasten the horse-power upon the hind axle of the wagon

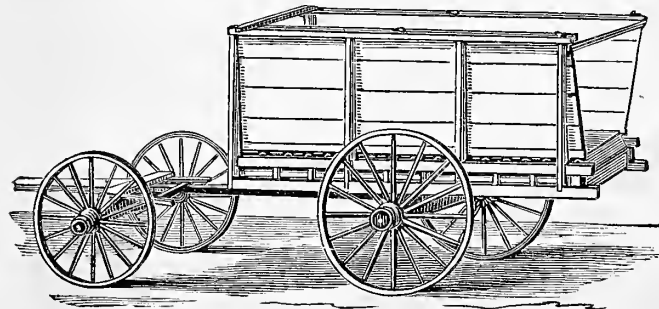

Fig. 3.—POWER READY FOR REMOVAL.

so that it may be readily tipped backwards. The reach is loosened from the fore part of the wagon when the power is to be used, and it is simply tipped up against the barn floor or upon it where it is needed. It may be propped up securely at the exact angle required. When it is to be removed the reach is brought down and fastened again into its place. Figures 2 and 3 show how this is managed.

Plan of Barn Yard.

We are asked for a plan of an inclosed barn yard suitable for a farm upon which the raising and feeding stock is the chief business, and in which economy of labor is of greater consideration than the first cost of the buildings. Having considered this matter and made some practical approach ourselves to the plan laid

out at figures 1 and 2, we are led to believe that there are many points of convenience and advantage in it, and that it will be of service to our readers. Fig. 1 represents the ground plan, in which the barn is shown at a. As will be observed there are no stalls for stock in this building; it is reserved altogether for storage for feed, grain, fodder, and apartments for preparing the feed. Upon each side of the barn are stalls, b b, for oxen or cows. At c c are stables for work horses, and loose stalls for mares, stallions, or colts. At d are loose stalls or pens for calves or young cattle or bulls. Each of these stalls should be 16 feet square inside, and a feed passage at least 5 feet wide should pass around the whole range and

through the central barn. At e is an office for the reception of tools and stable implements, the storage of materials for repairs and for making repairs of harness, etc., and for medicines and such surgical and other instruments as must of necessity be kept upon every well appointed stock farm. At f are the pig pens, with poultry roosts above them; the stairs at each end of the building giving access to store rooms for grain and feed for both pigs and poultry. At g are the manure wells, having cemented cisterns in the center, of such a depth as may be needed. If liquid manure is to be saved

and used, the cisterns should be 8 or 10 feet deep, covered with bars, and pumps should be attached to each one. The manure wells are surrounded with stone walls four feet high except at one end, for the purpose of retaining it in a compact shape and neat condition, and so that wagons or carts might be backed upon the manure to be loaded when desired. At h is the cistern which receives the whole water shed from the roofs, and which is carried off by spouts and pipes. The pump upon the platform should be a force pump so that the water might be forced to any part of the buildings, or into supply tanks for each stable, or by means of a rubber hose into scattered water troughs around the yard. At each side of the pig pen gates give admission to the yard, which should be paved with cobble stone where practicable on account of the extreme cleanliness and dryness which such pavement renders attainable. A side entry as at i will also be found a great convenience. There are many advantages connected with this plan which we have not space to enlarge upon, but which, upon examination, will be readily perceived. Where a sufficient number of stock is kept to make such an arrangement desirable, its cost will

be found much less than that of scattered buildings, while from a partial adoption of this plan in our own experience we can sug-

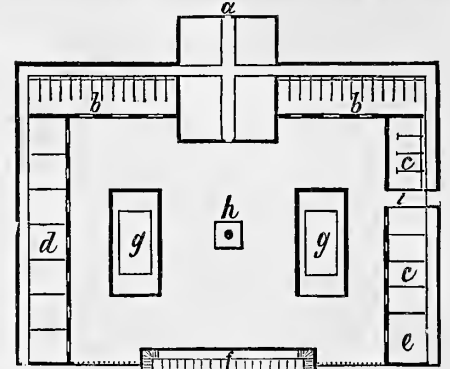

Fig. 1.—PLAN OF BARN YARD.

gest none that offers more conveniences. Figure 2 shows the elevation of the buildings, substantially but very plainly built. The plan

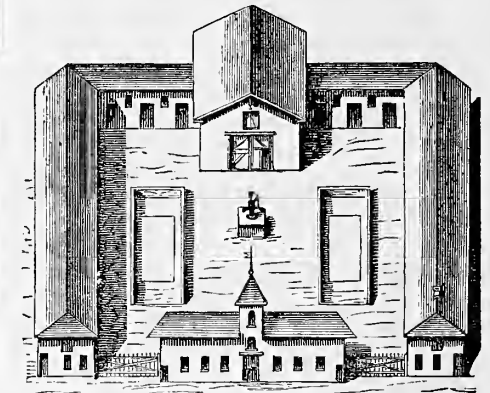

Fig. 2.—ELEVATION OF BUILDINGS.

admits of any amount of elaboration architecturally or otherwise that may be wished.

Concrete Building.

Charles Hodgkinson, Seott Co., Ill., sends us his plan of building concrete houses, which in many places in the West, especially where building materials other than lime and gravel are scarce and dear, may be found acceptable. He commences by making a solid foundation

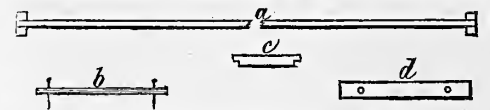

Fig. 1.—PLANK, CLEATS AND PIN.

of stone or brick-work and leveling the surface carefully. Upon this he places his set of boxing, shown in the engraving. The boxing or frames are made of inch boards 12 inches wide and all of one size. Cleats are nailed upon each end and on each side, as seen at a, to pre-

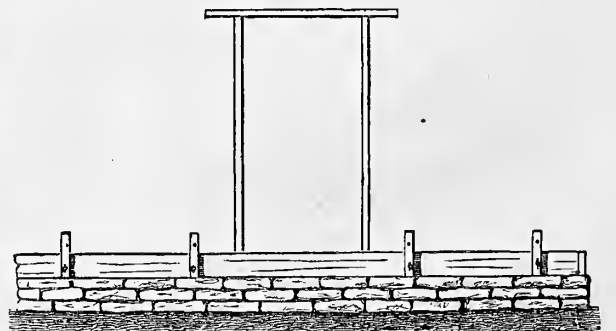

Fig. 2.—MANNER OF PLACING THE BOXING.

vent warping. Holes one inch in diameter are bored through the boards and pins of oak are

made to fit them loosely. A small hole is bored through each end of the pin into which a nail may be put to hold the board in its place. The pin is shown at *b*, and it is made long enough to pass through the walls and the boards and cleats upon each side of it, and two inches or more to spare at each end. For a 12-inch wall the pins would then be 20 inches long. Cleats two feet long, three inches wide, and an inch thick are then made as seen at *c*, and are bored to correspond with the holes in the boards for two sets of boxing. When these are ready the building is commenced by placing a row of boxing around the foundation, the boards being held apart by strips shaped like that shown at *d*. When the boxing is placed it is filled with the concrete, which is rammed solidly down. The concrete is made by mixing one

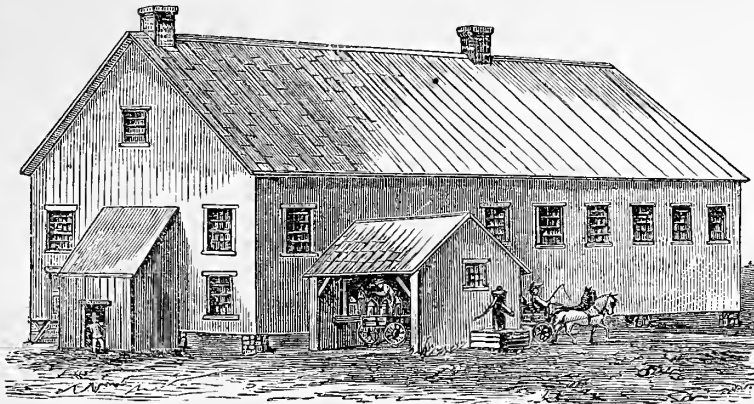

Fig. 1.—VIEW OF A CHEESE FACTORY.

boxing are used afterwards as sheeting for the roof, and no material is wasted.

How to Start a Cheese Factory.

The factory system of making cheese is easy and economical as compared with a private dairy. In a factory, the milk of 300 cows may be worked up with about the same labor and with about half the proportionate cost of materials as that of 30 cows in a farm dairy. If ten or more farmers can associate themselves into a factory company, and by so doing save the labor of nine of them and half the cost of furnishing ten separate dairies, it is an important economy. We need not

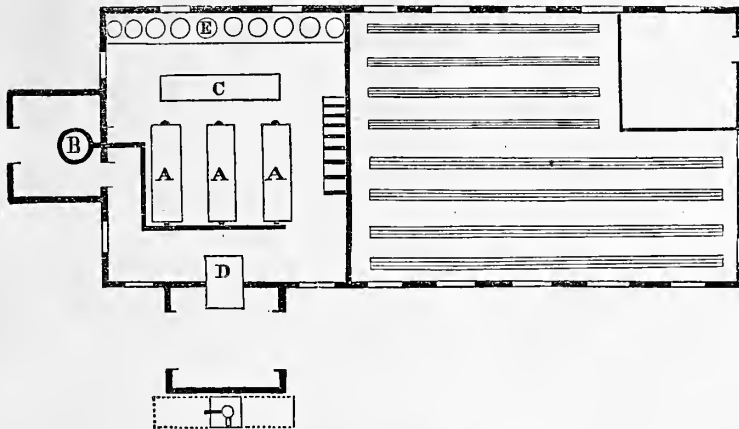

Fig. 2.—PLAN OF A CHEESE FACTORY.

part of good lime with two parts of clean sand and one of coarse gravel. This will occupy one day. The next day another set of boards are set up without removing the first set, the cleats projecting as seen in the engraving, being all ready to receive the boards. This set is then filled the same as the previous one. The next day the nails or keys are removed from the lower pins, and they are knocked out of the wall and the lower boxing is removed. The cleats are then swung around so that they are reversed, and the lower parts are then made to project above the second row of boxing. Another row is then placed in position and filled, and this process is repeated until the walls are raised sufficiently. The rate of building is one

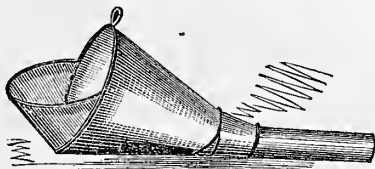

Fig. 3.—CONDUCTOR PIPE.

foot per day, which gives ample time for the consolidation of the concrete. The door and window frames are made of plank of equal width with the thickness of the walls, and are built into them. At the corners of the building at every foot square pieces of board are

enlarge upon this view of the case; it is apparent to everybody.

There are several methods of starting cheese factories. One is the joint stock system, in which the cost is divided into shares which are distributed in convenient proportions amongst the proprietors, who choose from their number a president as general superintendent, a secretary, treasurer, and a business manager or a committee of management. The shareholders supply milk to the factory according to the number of shares they own (one cow generally representing one share), and the expense of making the cheese and the proceeds of its sale are divided pro rata amongst the shareholders. The cheesemaker is hired and makes the cheese, furnishing all help and everything except the machinery at a fixed rate per pound of marketable cheese. Another plan is for one or more parties to own the factory and make the cheese at a certain rate per pound of cheese sold, the cheese belonging to the patrons or farmers who supply the milk and sold on their account by a person or committee ap-

pointed by them. Another plan is for the factory to be owned as in the last preceding case, and to purchase the milk outright from the patrons at so much per pound, and pay for it in cash as may be agreed upon. The cheese then is the absolute property of the owner or owners of the factory. In general practice this last plan is found the best and the freest from occasions for dispute or disagreement. Unfortunately it has been found necessary under whichever system a cheese factory is managed, to make very stringent regulations and agreements, and to attach severe penalties to their violations in order to prevent adulteration of the milk, not so much through dishonesty, as has been said by Mr. Harris Lewis, a noted dairyman and factory expert, as to rivalry as to who should produce most milk.

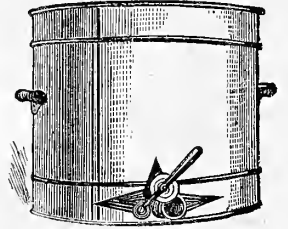

Fig. 4.—WEIGHING CAN.

When, however, the preliminary arrangements have been made, the site and building become the next considerations. The site should be dry, free from any taint in soil, water or atmosphere, with good drainage and well supplied with cool spring or well water in a constant flowing current, by gravitation or by means of mechanical power. The building should be proportioned in size to the number of cows supplying it. For a private factory for 30 to 60 cows, a building 18 x 24 would be sufficient, with the upper story for a curing-room. For 100 cows, the building should be 28 x 45, with 18 feet posts. 18 feet at one end should be partitioned off for a making-room, and the remainder, with the whole upper floor, will be used for the curing-room. For 200

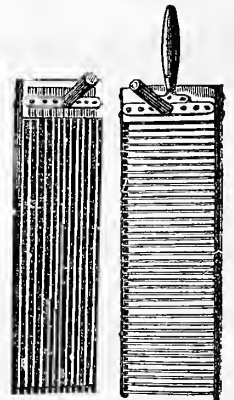

Fig. 5.—CURD KNIVES.

For 200 cows, the building should be 55 feet long; for 300, one will be required 65 feet long, with an

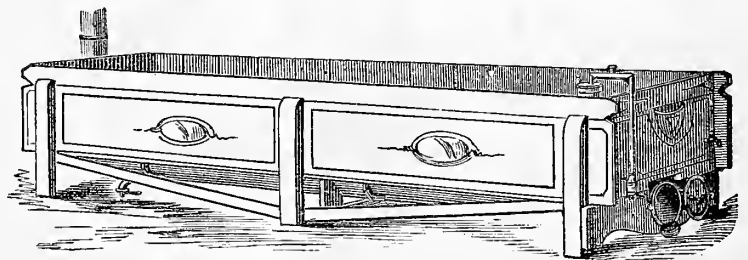

Fig. 6.—ONEIDA VAT.

addition of 6 feet to the width of the making-room, 20 feet long. For 400 cows, it should be

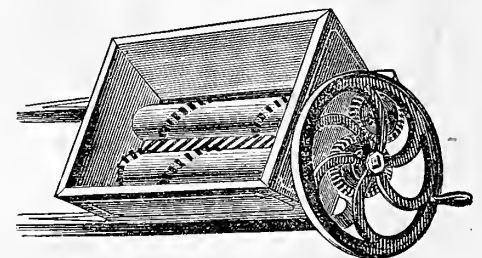

Fig. 7.—CURD MILL.

addition of 6 feet to the width of the making-room, 20 feet long. For 400 cows, it should be

75 feet long, by 36 wide. For larger factories with 600 to 1,000 cows, it may be better to have the curing-room a separate building from the

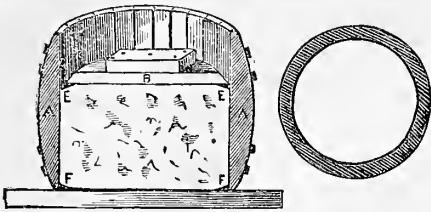

Fig. 8.—PRESS RING AND HOOP.

make-room. In such a case, the make-room might be connected with the dwelling provided for the superintendent, and a building 24 x 40 feet or larger should be provided for it. The curing-room would then need to be made from 24 to 36 feet wide and 75 to 120 feet long. The general character of the needed buildings may be gathered from the accompanying engravings. Fig. 1 represents a factory of 600 cows, at Rutland, Vermont, which we recently

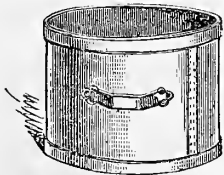

Fig. 9.—IRON PRESS RING.

visited, and which includes dwelling-rooms, make-room, and curing-rooms. The small addition at one end holds the heater by which the curd is cooked, and that at the front is the covered driveway at which the milk is received. In front of the driveway is a platform upon which is fixed a pump for delivering the whey which is stored in a vat beneath it.

The interior arrangement of this factory, shown at fig. 2, is very similar to that of other cheese factories. The make-room is supplied with vats, AAA, which are heated by steam pipes passing from the heater, B, in the adjoining room. The whey is run off through pipes into the vat already mentioned. The draining vat, C, is placed so that the curd may be readily dipped from the milk vats into it. The weighing platform, D, is connected with the receiving platform outside, and is made such a high that the milk may run from the weighing can, fig. 4, by means of the conductor head and pipe, fig. 3, into the cheese vats, where it is immediately cooled down until all the odor is dissipated. For small factories in which no heater or steam engine is needed, the Onida vat, fig. 6, is used, which is provided

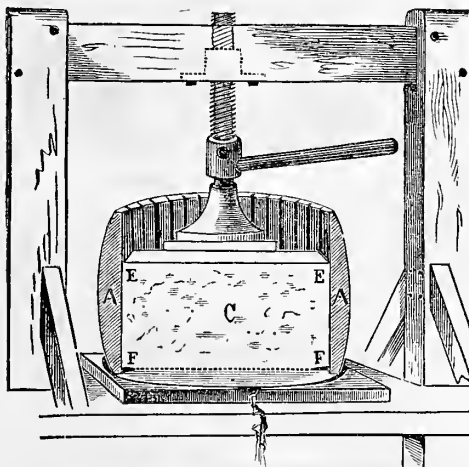

Fig. 10.—SINGLE CHEESE PRESS.

with heating apparatus for cooking the curd. After the curd has formed, and before it is cooked, it is cut into small cubes with the curd knives, fig. 5. After cooking, the curd is dipped into the draining vat, C, fig. 2, where it is suffered

to cool. It is then ground in the curd mill, fig. 7, which, in small factories, is operated by hand, but in large factories by a steam engine. The press hoops now come into use. Those for small factories or private dairies are of wood, fig. 8, or of iron, fig. 9. The press is shown at fig. 10. For large factories the gang press, fig. 11, is now generally used, and is found very economical. The presses are ranged around the make-room, E, fig. 2, and a drain carries the drip of whey from them to the whey vats. After the cheeses have become compact, they are removed from the presses and taken to the curing tables. These are long tables of wood free from resinous or other matter that would flavor the cheese, about 3 feet high and 33 inches wide, or sufficient to hold two rows of cheeses. In the New York factories the tables are generally closely jointed

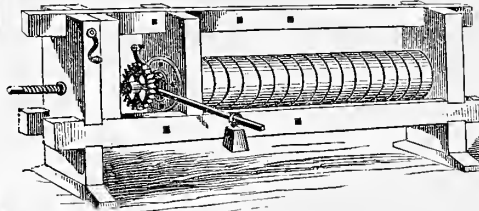

Fig. 11.—GANG PRESS.

at the top, while those in the Vermont factories are formed of bars or scantling placed longitudinally three or four inches apart. We are not prepared to decide which of these forms is the better, but our preference is for the Vermont fashion. These tables need to be very strong to sustain their load of cheese. Indeed, the whole of the building needs to be

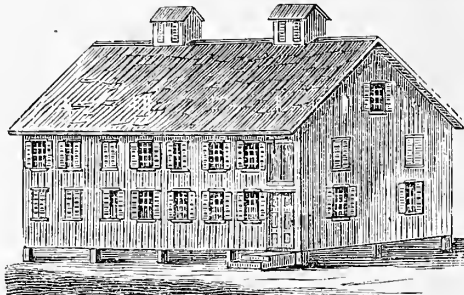

Fig. 12.—CURING HOUSE.

substantial and solid, although it may be of the plainest material and workmanship consistent with economy. Fig. 12 shows the curing-house belonging to the Whitesboro factory in Oneida Co., New York. This curing-house combines all the requisites needed; it has perfect ventilation beneath, being elevated upon posts, non-conducting double walls to preserve the necessary evenness of temperature, thorough ventilation above, shaded windows, and within, spacious airy apartments. This curing-room we consider a model one, as indeed is the whole factory as to its management, although the make-room is somewhat old fashioned, for the cheese from this factory has acquired a high reputation in England.

The cost of the factory building depends altogether upon that of the materials, and very close estimates can be made in any locality from the descriptions here given. The apparatus, such as has been described for a dairy of 20 cows, will cost at the manufactory in the city of Utica, N. Y., the headquarters of this business, about \$70 to \$90; for 30 cows, \$90 to \$120; for 40 cows, \$105 to \$145; for 70 cows, \$135 to 180; for 100 cows, \$260 to \$325; for 200 cows, \$400 to \$475; for 300 cows, \$555 to \$700; and for 400 cows, \$650 to \$820.

Varieties of Milk.

That the milk yielded by cows of various breeds differs very much in quality and character is a well-known fact. For this reason it is necessary that the dairyman should select a certain breed of cows which he has learned by experience or otherwise is best suited for his special branch of this business. The maker of fancy butter chooses the Jersey as his cow, for the reason that from her milk the cream rises very rapidly and in large quantity, churns quickly, and yields a rich-colored, fragrant

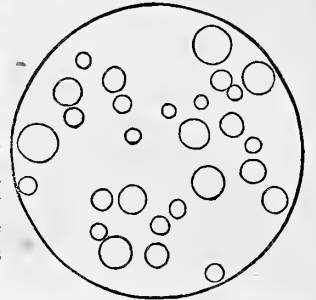

Fig. 1.—JERSEY MILK GLOBULES.

butter. The Ayrshire breed furnishes not only a cow second only to the Jersey for the butter dairy, but one which is pre-eminently a cheese producer; while the Ayrshire and the Dutch breeds are best suited for the dairyman who supplies towns and cities with milk. That these peculiarities in the several breeds here noted were due to some peculiar characteristic of the milk was very evident, but exactly what those characteristics were, has not been generally known. The composition of milk has long been under investigation, and many microscopic examinations of it have been made, which have shown it to be a complex fluid in which are suspended a varying quantity of globules of fat or butter, each inclosed in an enveloping film, or membrane. These globules being lighter than the milk in which they are suspended, rise to the surface when the fluid is kept at rest, and form what we know as cream. When this cream is agitated or churned, the sack inclosing the globule of butter becomes broken, by the crushing or wearing action of the dash of the churn, and the butter separates. All this has long been known, but why the cream of the Jersey cow or of some other cows of a similar character should rise rapidly and abundantly and should churn readily, and why the skimmed milk of these cows should be very blue and poor, yielding a very poor cheese, known from its character as a "white-oak" cheese, while exactly the contrary should occur with an Ayrshire or a Dutch cow, remained a matter for investigation. At the last winter meeting of the Vermont Dairyman's Association, Dr. E. L. Sturtevant, of Massachusetts, gave the results of over 9,600 microscopic examinations of the milk of the Jersey, Ayrshire, and Dutch cows, from which he gathered that

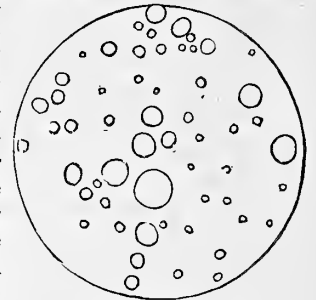

Fig. 2.—AYRSHIRE MILK GLOBULES.

very blue and poor, yielding a very poor cheese, known from its character as a "white-oak" cheese, while exactly the contrary should occur with an Ayrshire or a Dutch cow, remained a matter for investigation. At the last winter meeting of the Vermont Dairyman's Association, Dr. E. L. Sturtevant, of Massachusetts, gave the results of over 9,600 microscopic examinations of the milk of the Jersey, Ayrshire, and Dutch cows, from which he gathered that

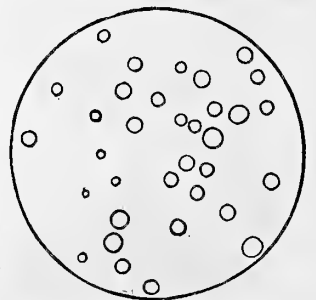

Fig. 3.—DUTCH MILK GLOBULES.

the butter globules of these varieties of milk are very distinct in appearance, and that their different characters very readily account for their different behavior in the dairy and in the churn. For instance, the Jersey butter globule is larger than that of the other breeds, and is of a more uniform size, there being in Jersey milk very few small globules or granules, as they have been termed by himself and other investigators. The character of the globules in the Jersey milk is shown at figure 1, A. At figure 2 is seen the character of the globule of the Ayrshire milk, and at figure 3 that of the globule of the Dutch milk. The cream of the Jersey milk, consisting of large globules, rises quickly, sometimes separating wholly in four hours, leaving a blue skim-milk beneath; the cream of Ayrshire milk requires over ten hours to rise only in part, leaving a very white and still rich skim-milk. Amongst the Ayrshire cows there exists a family of butter cows whose milk throws up the cream almost as rapidly as that of the Jerseys. The Dutch milk throws up the cream more quickly than the Ayrshire, but the globules being comparatively small the cream is readily mixed with the milk again by stirring. This cannot be done with the Jersey milk. The Jersey cow, therefore, stands first as a butter producer, but is a poor cow for producing milk for sale, and a very poor one for cheese; the Ayrshire cow stands next to the Jersey as a butter cow, but first of all for the cheese dairy or for the milkman, and is therefore pre-eminently the useful cow for all purposes. The Dutch cow stands second to the Ayrshire and before the Jersey for the purposes of the cheese maker or the milkman, but third and last as a butter cow. These characteristics, well known in practice, are explained when we come to examine closely the character of their milk.

Laying out a Western Farm.

In the western states where land is subdivided into squares or parallelograms, the laying out of a farm would seem to be one of the simplest things possible. Nevertheless frequent mistakes are made in doing this, which add to the cost of fencing, to waste of land and to waste of time in passing to and from work, and in hauling in the crops. A square field requires less fencing than one of greater length than breadth. If there are more roads than necessary, land is wasted; and if the homestead is at one end or one side of the farm, much time is lost in reaching the distant fields. In the accompanying plan we propose a method of laying out a farm which avoids all these wastes, and in which the homestead is not only in the most convenient position, but is sheltered by belts of timber and plantations from the prevailing winds.

The homestead faces the east, and is supposed to be in the center of an 80 acre or a 320 acre tract. For a 40 or 160 acre tract which is square, the same general arrangement would answer. The fields are squares of 10 acres each in an 80 or 160 acre tract, and 40 acres each in one of a 320 acre. A belt of timber is placed across the north end of the tract and along the east side of the northeast field. Another plantation is made in the northwest corner of another field; both of these together will furnish protection to the farm and the farm buildings, which should be placed somewhere near the smaller belt of timber and within its protection. The house is surrounded by an orchard at the rear, and scattered groups

of trees ornament it and shelter it upon the east and south. If those who are now settling up the vast prairies would take some pains to lay out their new farms and plant their orchards and protecting groves in some such method as is here described, the face of the country would very soon become a scene of unsurpassed beauty, and the present bleak, unsheltered, dreary aspect of the landscape in winter would disappear in a few years. The money value of the timber, and the shelter with its accompanying beneficial influence upon the climate would far more than pay the cost of labor and the very small necessary outlay of money. In the plan there are no farm buildings laid down, as the slope or other configuration

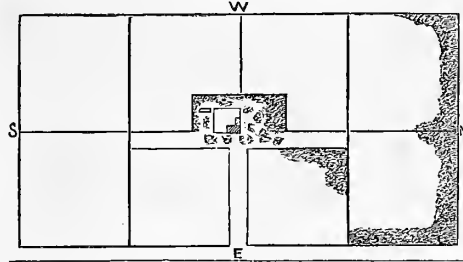

PLAN FOR LAYING OUT A FARM.

of the ground and the supply of water would affect the choice of their location, but in general it would be found convenient to place them near the homestead where we have indicated.

CULTIVATION OF TOBACCO.—The magnificent castles in the air which have been erected during the past few years by the over-sanguine tobacco growers now lie in ruins. The unfortunate builders are disappointed and disgusted. It was ever thus with growers of what may be called special crops. For a few years large profits tempt greater ventures and then come excessive crops for one or two seasons and prices go out of sight. A Connecticut farmers' club has of late discussed this matter. It was there stated that in Franklin County there was enough tobacco for sale to give 25 dollars to every person, old and young, in the county. We have heretofore cautioned our readers that this result might happen; that tobacco was one of those illegitimate crops, so to speak, which might be profitable for a season, but were a poor dependence. What is to be done? A tobacco stubble makes an excellent ground for a corn crop or a root crop. We have heard of 45 bushels of wheat having been harvested from one acre of tobacco land in Massachusetts; 100 bushels of corn would not be a more valuable crop, which with the fodder, would bring nearly \$100 per acre; this would be probably as much as many tobacco crops in the palmy days of the business have yielded, net, and twice or four times as much as it would now yield. It is now a good time not to grow tobacco. When the surplus is worked off it will doubtless be again profitable. Tobacco is a risky crop.

FRENCH AGRICULTURE.—The superficial area of France, according to the official returns, consists of 115,500,000 acres. Of these over 36,000,000 acres are owned by proprietors whose estates cover only 8½ acres upon an average. Over 16,000,000 acres are owned in farms of an average size of 35 acres; over 19,000,000 acres consist of farms of an average of 87½ acres, and of farms of an average of 415 acres there are but 43,000,000. Nearly twenty million of the population subsist upon the smallest sized farms; two and a half million upon those of an

average of 35 acres, and only one million upon each of the other classes of farms. The consequence is that three fourths of the population never taste sugar or beef, but live in the greatest economy upon bread and vegetables and drink water or the poorest wine or cider.

How Leather is Tanned.

The business of tanning leather is a rather complicated one, and can not be well undertaken without the expenditure of a good deal of capital in buildings and machinery. As the process occupies some months, it is also necessary that a large stock of material should be accumulated, and this adds to the amount of capital needed to carry on the business. A very small tannery would require \$20,000 to put it in operation, and there are many large ones in which ten to twenty times that amount is invested. It is also necessary for the business that a supply of bark should be near at hand; we therefore find the tanneries near extensive tracts of timber land in which oak and hemlock predominate. The stripping of the bark from the trees can only be done in the spring; that from oak trees is only to be procured in the month of May, while that from hemlock can be stripped during May and June. The whole year's supply of bark must therefore be secured in these months and piled up and stored for use. Very large sheds are needed at every tannery for storage of the bark. Fig. 2 of the accompanying engravings shows the method of gathering the bark. The trees are cut down, and the bark is cut all around the tree every four feet in length with the axe. It is then split from cut to cut. A long handled spud or blunt chisel is then inserted beneath the bark, and if peeling well it separates with great ease in one piece four feet long all around the tree, otherwise it comes off in smaller pieces. The bark is laid out to dry, and then piled up into cords ready to haul to the tannery, where it is stored under cover. In drying the bark care must be taken to keep it from mildew, which spoils its color and quality. The bark is ground as it is wanted for use in strong iron mills, fig. 3, to a coarse powder. The ground bark is taken from the bark mill by means of conveying spouts, or elevator cups, like those used in grist mills but much larger, to the leaches, where it is soaked in hot

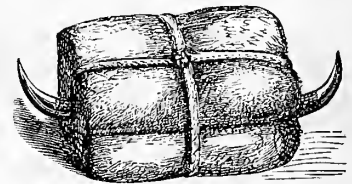

Fig. 1.—A HIDE DONE UP.

water until all the strength is extracted, and a dark liquor, very much like strong coffee in appearance, is strained from it. The waste bark is what we know as tan-bark, and is useful for packing ice, bedding for cattle when dry, and for making gentle hot-beds. The tan liquor is run into large vats for use. The hides undergo various preparatory processes before they are put into these tan vats. They come to the tannery either in the shape seen in figure 1, which is a green country hide, properly folded and tied, or as dry or green salted. In this last shape they have no horns attached and are tied up in somewhat the same shape as the fresh hides, but having been kept for some time, or coming from South America or Texas, they do

not smell very agreeably. At the tannery they are first put into soak vats, which are filled with water only. Here the salt is dissolved out of them, and all dirt and sand which adheres to



Fig. 2.—COLLECTING TAN BARK.

the hair is loosened and separated. They then go to the lime vats, figure 4, in which they remain eight days in strong lime water, being occasionally turned and moved from one vat to another, by means of hooks fastened to the ends of long poles. This lime water loosens the hair so that when, after the lime bath, the hides are put upon the "horse," figure 5, and scraped,

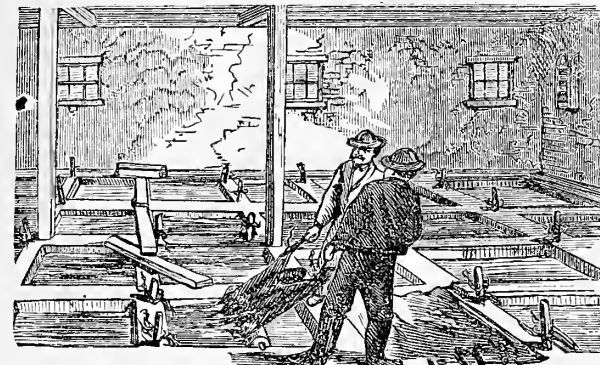

Fig. 4.—THE LIME VATS.

the hair is all removed with ease. The flesh which may remain upon them, and all rough tags, are shaved off with the sharp edge of the knife which is seen in the workman's hands. After the scraping the hides are put into other vats in which there is a solution of hen manure for the purpose of freeing them from lime. Here they remain six days, when they are bathed in a somewhat rough manner, by means of wheels similar in shape to water wheels or paddle wheels of a steam boat. These wheels

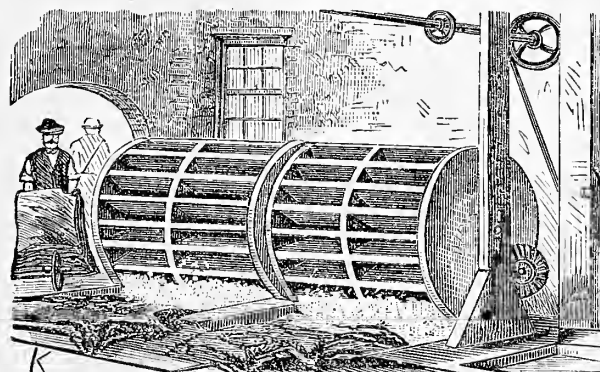

Fig. 6.—BATHING WHEELS.

are shown at figure 6. After this process they become very soft and smooth. They are then put into the vats of tan liquor, figure 7, and here the process of tanning really commences, all the previous processes being merely preparatory. The tan liquor contains, as is well known, a strong astringent principle, which it

has dissolved out of the bark. This astringent principle is called tannin. It has the chemical property of rendering the gelatinous part of the hide insoluble in water, and almost indestructible so long as it is kept dry. It is this which changes the hide into leather—a chemical union of the tannin is formed with the glue or gelatine of the skin. A long time is required for this change to take place, and the hides remain in the tan liquor for three months before it is complete. They are, however, handled many times during that period, and are removed frequently from one vat in which the tan liquor

has become exhausted, into others filled with fresh liquor. When this process of tanning is complete, and the hide has become leather, nothing remains but to dry it in the upper rooms of the tannery, where currents of air are admitted through slatted or open windows. It then appears as a yellowish brown skin, hard, tough, and flexible, and thick or thin according

to the kind of hide which has been tanned. It is then split down the middle and becomes two sides of leather. Heavy ox-hide or cow-hide is made into sole leather; light cow-hide, two-year old hides or kips, and calfskins are colored black and curried and used for upper leather; the best of the cow or ox hides are selected for harness leather, which requires not only great

strength, but great solidity and density, to fit it for the use to which it is to be hereafter put.

Farmers' Clubs.

We notice with great satisfaction the increase of these institutions in all parts of the country, and notably in the New England States, and the provision they are making for the entertainment of rural communities. They are so well managed in many places that they contribute a

very important element to the social and intellectual life of the people. They are taking the place of lyceums, and to some extent of balls and fashionable parties. Their informal and business character makes them attractive to many who think they have no time for visiting and social enjoyments. Pomology and floriculture receive a due share of attention, and make the meetings acceptable

to villagers, who have only fruit yards, gardens, and conservatories. Indeed, the most flourishing clubs generally have their center in the village, and the winter meetings are held in some public hall. Sometimes a course of lectures is given which draws full houses from village and country. Often there are dis-

sussions upon questions of practical interest which bring out the experience of the best cultivators in the town. Exhibitions of fruit and flowers and exchanges of grafts and seeds and eggs are

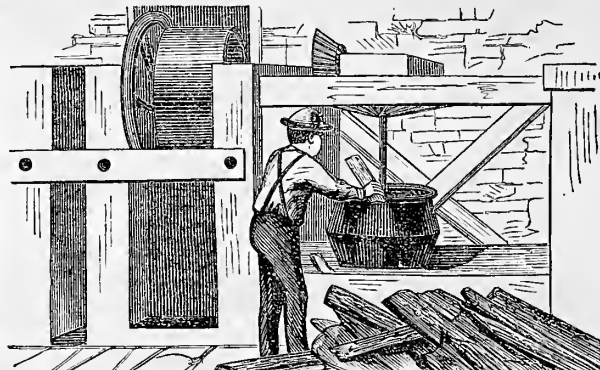

Fig. 3.—GRINDING THE BARK.

frequent adjuncts of these meetings, and not the least important of their advantages. The educating power of these clubs is very great. They quicken thought in many ways. They direct the attention to the best methods of husbandry. They serve to economize time and labor, and introduce new fruits, flowers, implements, and stock. They break up the dull rou-



Fig. 5.—SCRAPING THE HIDES.

tine of the farmer's life, and are doing something to make farm life attractive to the young. We have often called the attention of our readers to the value of these clubs in past years, and are glad to see that the good seed sown is springing up in so many places. The State Board of Agriculture in Connecticut has been doing a good work the past winter, in holding meetings in connection with these clubs in various parts of the State, for lectures and discussions. The meetings have generally been con-

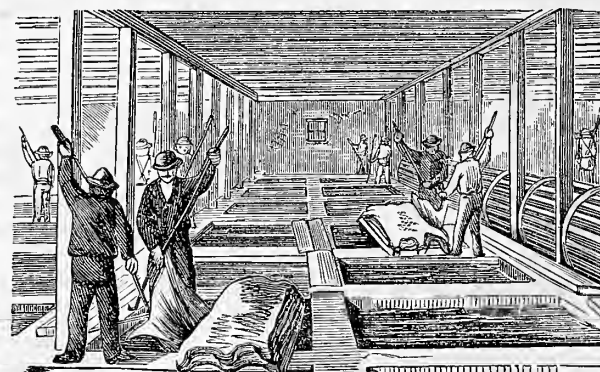

Fig. 7.—THE TAN VATS.

finned to one day in a place, holding three sessions. Lectures have been given by Professors Johnson and Atwater, and by the Secretary, T. S. Gold, with discussions at the close. It would do much to popularize the work of our boards of agriculture if they would follow the example of Connecticut in all the States.

Annuals—Drummond's Phlox.

When Mr. James Drummond, some fifty years ago, first saw the little Phlox which now bears his name, he could hardly have foreseen that it would become perhaps the most popular annual in cultivation; and instead of the rose-purple color that belongs to it in its native state it would "break" into a great variety of colors and shades which would receive distinct florists' names. The writer has seen it covering large stretches of prairie, where, though pretty, it appears rather common, and bears but little resemblance to the choice and brilliant varieties of the garden. Drummond's Phlox, or *Phlox Drummondii*, as the catalogues have it, is one of the few annuals that the English gardeners admit in their lists of plants for the elaborate bedding designs now so much in favor in their country, but which have not been extensively practiced in this. Those who wish to attempt the massing style of planting will find the different varieties of this Phlox well suited to experiment with. The plants vary but little in height, and there is no trouble on account of a difference in growth as where several plants of a different kind are used. In colors there are pure white, rose, pale yellow, several shades of crimson and purple, and the most brilliant scarlet, and besides various combinations of color, as pure white with purple eye, purple with a white center, and several with stripes and marblings of contrasting colors—surely variety enough for one plant to produce. A circular or oval bed planted with successive lines of strongly contrasting colors makes a most brilliant show. We rarely see this plant in perfection, and the same may be said of other annuals. A packet of seeds that costs but ten cents may produce 50 or 100 plants. As each plant costs so little, only the fraction of a cent, it is very natural that it should not receive the same care that would be bestowed upon a Geranium or other plant purchased from the florist for 25 cents. Hence, annuals are generally crowded, ill-shaped, weedy looking affairs, which after a short season of bloom, die away, or become so utterly shabby that they are pulled up in disgust. To have this Phlox in its best condition it should have proper treatment, and what is advised for this should be followed with most other annuals. The seed should be sown this month in boxes of light rich earth; sow thinly in drills, keeping the varieties distinct; those who can may place the boxes in a gentle hot-bed, but a sunny

window will answer quite as well. When the plants are large enough to handle transplant them to other boxes, setting them two inches apart each way; shade for a day or two, and then give them plenty of light, but do not scorch them; water as needed, and give air when the outside temperature will allow.

flower, and it may happen that a line will have a "rogue" or two—that is, plants that have not come true to kind; such plants should be taken up as soon as they "show their colors," and replaced by those that have been kept in reserve; being in pots they may be turned out without checking their growth, and any unseemly breaks in the bed be avoided. If the branches of one row grow in with those of the next, so as to destroy the well defined line between them, the scissors must be used to remove all unruly growth. To secure a long continuance of bloom no seed should be allowed to ripen on the bed; as soon as a cluster has passed its prime clip it off; if allowed to bear seed the plants will become exhausted. If it be desired



A GROUP OF DRUMMOND'S PHLOX.

When the plants are about three inches high "stop them," as the gardeners say, which means to pinch out the growing point in the center; this will have the effect of making them throw out side branches, and for this reason the distance of two inches was advised in transplanting. Before the time for setting out, in May, or whenever the ground is well dried and warmed and cool nights are over, the plants should be thoroughly hardened off by exposure in boxes, day and night, to the open air. One great trouble with this plant is its tendency to mildew, which may be avoided by giving plenty of room. Most of the varieties grow about a foot high, and these should be set a foot apart; some of the newer varieties are said to be only six inches tall, and these may be placed as many inches apart as they are high; these low-growing kinds must be planted at the margin of a

to raise seed for another year a plant or two of each kind may be set in another place expressly for this purpose. It may be added that the seeds should be gathered as soon as the pods begin to turn brown, or else they will open on the plant and the seed be lost. We have given thus in detail what we consider the treatment best for the majority of annuals. Some do not need to be pinched, but the other points must be observed if really good results are desired. The engraving here given is from the new and elegant catalogue of Messrs. Briggs Brothers, Rochester, New York.

Combined Cellar and Greenhouse.

BY PETER HENDERSON.

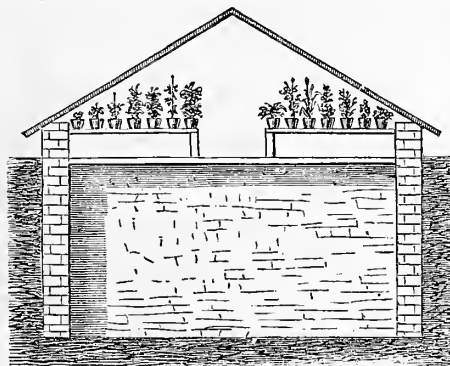

A COMBINED CELLAR AND GREENHOUSE.

bed with the taller ones nearer the center. In planting a bed with lines of various colors it will be a good plan to put a few plants of each kind into small pots and keep them in reserve. The plants in the bed will soon begin to show

Many years ago an accidental circumstance gave me an opportunity of proving the utility of combining a cellar and greenhouse under one roof. An excavation of 20 feet by 40 had been made, seven feet deep and walled up with stone, and the beams laid across preparatory to placing a building on it, when the owner changed his plans and found himself with this ugly excavation but a dozen yards from his costly residence. There seemed to be no alternative but to fill it up or plank it over; but both plans were objectionable, and in discussing how to get out of the difficulty I suggested erecting a low-roofed greenhouse over it, as the owner had a taste in that direction. This suggestion was followed, raising the walls one foot above the surface and erecting a span roof of glass.

My idea (which was found to be nearly correct) was that the large volume of air in the excavation, which would at all seasons average about 40°, would be sufficient to keep the upper or greenhouse portion of the structure above

the freezing point in the coldest weather. This it did completely when the glass was covered at night with shutters; and the plants with which it was filled, of a kind requiring a low temperature, kept in better health than if they had been grown in a greenhouse having fire heat.

Now, although I have never seen such a combination since, I am satisfied that in favorable circumstances such a structure might be made of great advantage and at a trifling cost, for as it dispenses with heating apparatus, which usually is more than half of the whole cost in all greenhouse erections, the use of a cellar and greenhouse could be had at probably less than the cost of an ordinary greenhouse; and for all half hardy plants—plants that will do well in winter if kept but above the freezing point—such a greenhouse will be better for many varieties than any kind of greenhouse heated by fire heat. All kinds of Roses, Camellias, Azaleas, Zonal Geraniums, Violets, Cape Jessamines, Carnations, Abutilons, Verbenas, Primulas, Stervias, and, in short, all plants known as cold greenhouse plants, will keep in a healthy though nearly dormant condition during the winter months, but growing and blooming with increased vigor at their natural season of growth, and flowering as spring advances. Besides the cellar may be used for the ordinary purposes of such a place; or if exclusively for horticultural purposes, no better place can be had for keeping all deciduous hardy or half hardy plants, Hyacinths in pots to start to flower, or any bulbs of similar nature. The great point to be observed is that the soil where such a structure is to be formed is entirely free from water, or if not so naturally must be made entirely dry by draining.

The style that I think would suit best for general purposes would be twelve feet in width, and of any length desired. The excavation should not be less than seven feet deep, walled up to about one foot above the surface. When complete it would show something like the section in the cut annexed. If the glass roof is made fixed it should have ventilating sashes 3×3, at intervals of six or nine feet on each side of the roof; if of sashes they should be seven feet long by three feet wide, every alternate one made to move for ventilation in the usual way. The position of the structure would be best ending north and south. The shutters best for covering the glass with at night are those made of light half-inch pine board, three feet wide by seven feet long.

It will be understood that the advantage of this combination of cellar and greenhouse over the ordinary cold pit is that the air of the greenhouse is warmed or equalized by mixing with the atmosphere of the cellar, which will rarely be less than 40°. For the same reason, if a high temperature by fire heat was wanted, say 70°, this atmosphere of 40° from below would make it difficult to be obtained. It will be necessary, of course, to have the flooring boards covering the cellar wide enough apart to freely admit the air; this will at the same time give light enough for any operations necessary to be done in the cellar.

Treatment of Tropical Bulbs, Seeds, etc.

BY PETER HENDERSON.

Any information that can be given in an article short enough to be suitable for your columns on a subject so extended as this must be confined to a few well known and leading plants most valued for general cultivation.

First may be placed the Tuberose, which in most Northern States must be artificially forwarded to bloom in perfection in the open air. The seasons are too short for the full development of the flowers in fall unless the bulbs are so forwarded. All that it is necessary to do is to place the dry bulbs in soil in pots or in boxes about May 1st (not before), keeping them rather dry until they start to grow freely, when more water may be given. Plant the bulbs thus started in the open border the first week in June. The bulbs while being forwarded may be kept in any place where the thermometer ranges from about 65° to 75°. At night we usually place them under or alongside the hot-water pipes in our greenhouses, covering them up with paper to keep the heat of the pipes from them. Light is not necessary until they have well started to grow. A greenhouse is not at all essential to start them in, as a hot-bed or even a warm sitting-room will do nearly as well. Any one wishing to have their Tuberoses "started" can do it themselves just as well as a florist can, and as the dry bulb costs less than half the price of the started one, and is more safely transported by mail or otherwise, any one taking the trouble to do it will save expense and have the bulbs in better condition for planting.

Some of your readers have seen or cultivated the bulbs known as fancy or spotted-leaved Caladiums. There are probably no plants that assume such a varied and wonderful marking of the leaves as these, and when properly grown they are among the most attractive plants at our horticultural fairs. The continued high temperature necessary for the healthy growth of the Tuberose is equally indispensable for the Caladium. The bulbs we treat at first exactly in the same manner as the Tuberose; that is, they should not be started much before May 1st, and never should they be kept for any length of time in a less temperature than 65°. They are best started in small pots, and should be shifted into larger ones as soon as these get filled with roots. Started in May, and properly treated, they should be large enough by August or September to require a flower-pot twelve inches in diameter, and the plant should be, according to the variety, from two to three feet in diameter across the leaves. Caladiums require a partial shade, and if kept in a greenhouse during summer the glass should be shaded, but the light of an ordinary sitting-room would just be about right; so that even those not having a greenhouse can grow these rather rare and beautiful plants with perfect ease. The only thing necessary, if grown as a window plant, would be to turn the plant around every few days so that each side would get the light—a necessity with all plants grown in windows. The soil best suited for its growth is that known as sandy loam, to which should be added one-third rotted manure or leaf mold.

The same time of starting and a similarly high temperature is required for Begonias of all kinds, Bouvardias, Cissus, Coleuses, Dracenas, Euphorbias, Poinsettias, and all other plants known as "hothouse" or "tropical," and the same general treatment will in nearly all cases lead to satisfactory results. All of the plants or bulbs referred to will dwindle or die if long kept in a low temperature, and hence it is important that amateurs should remember that they ought not attempt the cultivation of these plants unless they have the means of steadily keeping up the necessary high temperature. For that reason we recommend that

they should not be started before May, as at that time there is less chance of being chilled.

What is true of tropical bulbs or plants is equally so of tropical seeds. All seeds of tropical plants are safer, in the hands of those who have not had experience or the means of keeping up the necessary high temperature, not to be sown before April 1st. Of vegetable seeds the best known of this class are the Tomato, Pepper, and Egg-plant. I know they are often started in March in hot-beds or greenhouses with satisfactory results, but let any one try the experiment of sowing March 1st and April 1st, and note the result in the earliness of crops, and he will find that the chances are that the last shall be first; not but what if it were always practicable to keep the necessary temperature steadily along that the first sown would not be first, but that this is often very difficult to accomplish, while there is but little difficulty with the later sowing, as assistance is then given by the increasing outside temperature. For this reason, seeds of tropical annual flowers, such as Amaranths of all kinds, Balsams, Salvias, Double Portulacas, Cannas, Coxcombs, Zinnias, etc., should not be sown before April in the hot-bed, or if in the open ground, in this latitude, not before May 15th.

The Clematis.

BY AL FRESCO.

Like most enthusiastic amateurs I have my floral favorites, and one of my greatest pets is the Clematis. My impression is, that I was the first to import the new varieties raised by Mr. Jackman, and I well remember the pleasure it gave me to escort the editor of the *Agriculturist* to inspect the first blooms. After several years' experience, I must confess that my love for these beautiful climbers increases. Daily, during the course of last summer, carriages were stopped in front of my residence in order that the occupants might feast their eyes on the gorgeous mass of flowers, that in some places entirely hid the foliage from view. To me it was a source of pleasure to listen to the remarks and exclamations of those who were capable of appreciating the beautiful.

My practice is to plant a number of varieties in a clump, and by adopting this course the flowering season is prolonged. One circular bed four feet in diameter, contains *Clematis azurea grandiflora*, *C. Standishii*, *C. Jackmanii*, and *C. rubro-violacea*. The bed which has given me the greatest satisfaction contains *C. rubella*, *C. Lady Bovill*, *C. Prince of Wales*, *C. Jackmanii*, *C. rubro-violacea*, *C. Standishii*, and *C. azurea grandiflora*. "Tut! tut!" some of your horticultural readers will exclaim, "you planted too many in a four-foot bed." My answer is that the soil is nearly three feet in depth, and composed of two parts decayed turf and one part decomposed manure. During very dry weather, holes are carefully made between the plants, and these are repeatedly filled with water until the entire soil of the bed is thoroughly soaked. A few days before the first flowers open, the bed receives a good watering with liquid manure, and as a response to generous treatment a trellis six feet high and three feet diameter at the base presents almost a perfect mass of color for weeks, some of the blooms ranging from five to six inches in diameter. The Clematis will thrive in almost any soil or situation, but will amply repay the planter for any extra attention. In England the Clematis has been highly recom-

mended as a bedding plant. To test this matter I planted a number of the single species and varieties and among the double flowered ones, *C. Fortunii* and *C. Veitchii*, but the result has not justified the labor of preparing the soil and weeding the bed. The varieties of Clematis will bloom freely the first season they are planted. In April, '72, I received a number of plants from England, and when the case was opened I found that they had made a growth of several inches, and had developed flower buds. The young wood was removed, and they were planted out, and before fall favored me with numerous flowers. Each spring the owners of villa gardens spend many dollars in the purchase of Heliotropes, Geraniums, Fuschias, Lantanas, etc., which produce but few flowers, and are destroyed by the first frost. If they could be induced to cease the purchase of the plants referred to, and devote the amount expended for two or three years to securing one or more clumps of the Clematis, they would be rewarded for their venture. The Clematis is not the plant of a season, but improves in size and blooming capacity year by year. The branches of the Clematis are slender and easily broken by the wind. The plant has no tendrils, nor does it twine, but clings to supports by means of the leaf-stalks, which coil themselves around small objects. My favorite trellis for this class of plants is the top of a cedar tree, or bush, about six feet in length. I carefully remove the bark and shorten the branches so that it has a pyramidal form. When dry, I give it one coat of lead colored, and two coats of green paint. Before planting the Clematis, I obtain a chestnut, oak, or a cedar post, four by six inches, and three feet long. This post is firmly placed in the center of the bed and about six inches allowed to remain above the surface to which portion I firmly nail the cedar bush. To assist the young plants, I firmly place close to each plant a stick about one inch square, the top of which is beneath the surface of the ground. To each stick I attach a piece of about No. 20 copper wire and fasten the other end to the top of the brush. I find this brush and the wires to afford all the assistance the plant requires.

When frost has destroyed the foliage, I remove all dead wood and leaves, and carefully tie up what remains. To the inexperienced it will at first prove troublesome to determine what to leave and what to remove, but a careful examination will show where well developed buds exist, and the wood must be cut back to such buds. The wood of Jackmanii, rubro-violacea and allied varieties, dies back to within one to three feet of the ground, and the flowers of these are usually produced at the extremities of vigorous growths of the same season's production. The wood of Standishii and azurea-grandiflora is persistent and the flowers are mainly produced from small branches which grow from the old wood, and in consequence care is necessary to protect the last season's wood from injury. It is very small and brittle and easily broken, and requires care in handling. Jobbing gardeners usually trim all plants by rule, and I would advise the cultivators of the Clematis to keep these necessary evils from applying their rule to this tribe of plants.

The Clematis presents a fine field for experiment. Many of our native species are very ornamental, more especially the herbaceous section, and are capable of great improvement by hybridization. Hybrids are apt to sport from

seed, and I would advise all to sow the seed of the hybrid varieties, for some remarkable new ones may be obtained by adopting this course. Those at present under cultivation are allied in colors to the parent stock—blue, white, purple, and pink being the prevailing tints. What we require is a scarlet or crimson colored variety, and the raiser of seedlings may yet be rewarded by securing the prize. A scarlet or crimson colored Clematis with flowers the size of Lady Bovill, would prove to be the most ornamental garden plant possible. By careful selection and the annual production of seedlings, the result may not be far distant. In raising seedling Clematis, the experimenter will require patience, for the seed requires twelve months to vegetate, and under favorable circumstances the seedlings will not bloom before the autumn of the second year. From my experience, I can but say that several of my seedlings have rewarded me for the exercise of patience and perseverance, although a crimson variety has not rewarded my efforts.

Yucca or Bear Grass and its Uses.

If there is anything we like it is to meet a man with a horticultural hobby. We ought to be doubly gratified in the case of Col. Jas. T. Worthington, of Chillicothe, O., who has two hobbies, which he has rode very successfully for some years. One of these is to show that figs can be grown in Ohio, in the open ground, and the other is to utilize the Yucca or Bear Grass. We some years ago called attention to Col. W.'s estimate of the value of this material, and now having another letter from him we renew the subject. The common *Yucca filamentosa*, the Bear Grass or Adam's Needle, is a very common plant in our gardens, where it is cultivated for its subtropical foliage and its enormous clusters of white lily-like flowers. The kind grown by Col. Worthington has been by some botanists considered as a distinct species and called *Yucca flaccida*, but our best botanists regard it as a form of *Y. filamentosa*, with longer, more abundant, and less rigid leaves. The leaves of this, when properly cultivated, are three to four feet long and one to two inches wide; the plants grow so vigorously that in three or four years they form stools covering a space about four feet square and furnishing a great abundance of leaves. The flowers are very similar to the form so common in our gardens. In regard to the uses of this plant Col. W. writes: "For supplying cheap, strong strings and bands it has no equal; is excellent for tying up bacon, hams, corn shocks, vines, bundles of vegetables, mending baskets and other purposes when string or band is needed, and requires only to be known to be generally cultivated. The leaves of this plant will, I think, be eventually used for cordage, matting, and coarse cloths, instead of jute and other fibrous materials which we now import."

Experience with Tomatoes.

[The following garden record comes to us from Steel Bros., Laporte Co., Ind., which is not only interesting as an account of the performance of the different varieties in their locality, but as an example which may well be followed by those who would make a fair comparative test of tomatoes or other vegetables. This is, of course, a local experience, and as such is valuable, but we can point to cases in which both the Arlington and Canada Victor

made a much better showing—in fact, were equal to any.—ED.]

April 9th, planted under the same sash of hot-bed seeds of Trophy, Arlington, "extra-selected" Canada Victor tomatoes. We only got eight plants of Canada Victor.—May 2d, set out eight plants of each kind, in boxes six inches square filled with one half sandy soil and one half well-rotted manure, in a fresh hot-bed.—May 28th, set the plants in the open ground, in rich sandy soil, but without manure this year.—July 23d, picked the first tomatoes. The table below will give the result of all the pickings:

	Trophy.			Arlington.			Canada Victor.		
	No	lbs. oz.	Average oz.	No	lbs. oz.	Average oz.	No	lbs. oz.	Average oz.
July 23	1	7 7		1	7 7		7	2 2 4	6 7
" 25	4	2 5 9	1 3/4				7	2 2 4	6 7
" 28	5	2 12 8	4 5/8	4	1 12 7		11	3 6 4	10 1/7
" 30	3	1 10 8	2 3/3	3	1 10 7		3	13 4	1 1/3
Aug. 1	3	1 8 8		3	1 3 6	1/3	7	1 13 4	1 1/7
" 2				1	5 5		6	1 5 3	1 1/2
" 4	1	9 9		8	3 2 6	1/4	18	3 5 3	1 1/18
" 7	3	1 4 6	2/3	4	1 3 4	3/4	36	6 5 2	1 1/36
" 8	1	9 9		14	4 15 5	9/14	4	13 3	4 1/4
" 9	3	1 6 7	1/3	6	2 2 5	2/3	11	2 5 3	4 1/11
" 11	11	4 3 6 1/11		29	10 8 5	23/29	39	8	3 11 3/39
" 13	9	4 7 1/9		33	10 8 5	1/11			
" 15							22	4 10 3	4 1/11
" 18	40	18 7 1/5		50	15 8 4	24/25	15	3 4 3	7 1/15
" 20	40	16 12 6 7/10		55	15 12 4	32/55	37	5 12 2	18 3/37
" 22	50	19 9 6 13/50		70	15 9 3	39/70	34	6 1 2	29 3/34
Total	174	74 14 6 77/87		281	84 3 4 223/281		257	52 4 3 69/257	

August 21st, we had the most severe hail-storm ever known in this part of the country. It cut the tomato-vines so badly that we had very few afterwards. The pickings the next day were very much bruised. Some parts of our patch partly recovered, but none of the specimen plants ripened a perfect tomato after the hail. Owing to the cool, dry season tomatoes ripened very slowly this year. At the last of the pickings the Trophy was just beginning to ripen up well. The Arlington was apparently just in its prime. The Canada Victor was almost done bearing, and would probably not have lasted two weeks longer under any circumstances. The Canada Victor is early, but altogether too small for market, averaging only a little over three ounces. Probably one half were too small to sell at all. The Arlington is not quite as early, but larger, averaging almost five ounces, and very few very small ones. The Trophy is quite as early as the Arlington, and very much larger, averaging almost seven ounces. Every one must draw his own conclusions from this showing. We shall try all three varieties again next year, but shall not plant many of any except the Trophy.

FORCED PLANTS.—European florists force plants for commercial purposes much more than ours do, although ours are enlarging their operations in this respect. Last year there were many more thousands of the Lily of the Valley forced than the year before. With the French gardeners much attention is given to forcing the Lilac. Houses are built for the purpose without glass, as the forcing is done in the dark in order that the flowers may be white. Plants that have been forced are a long while in recovering. In small gardens, where space is valuable, it will hardly pay to try to resuscitate them. Hence garden plants that are forced into bloom for sale in the market and by peddlers are nearly useless to the purchaser until they have grown a year.

The Rock Tunica.—(*Tunica Saxifraga*.)

In forming a collection of herbaceous perennial plants with a view to determine their adaptability to our climate as well as their ornamental value, we have in the course of several years cultivated hundreds of species and varieties. Some of these die out of themselves, others after a fair trial are thrown out, while

the garden. It keeps on blooming for several months. The engraving was made with a view to show the size and shape of the leaves and flowers rather than the habit of the plant, which is not here represented. The delicacy and lightness of the flowers render them especially useful in bouquets for vases and the like, as they give a grace that is often wanting in such bouquets. If we wished, we could easily pro-

plant does not belong to the family of the clover and pea. The flowers are yellow, with four petals and six stamens; the pistil is curiously raised upon a stalk, a character which with others shows the shrub to belong to the caper family. The pod is more than an inch long, and contains several seeds the size of a small pea. Nuttall first described this shrub, and called it *Isomeris arborea*. *Isomeris* means

ROCK TUNICA.—(*Tunica Saxifraga*.)THE CALIFORNIA ISOMERIS.—(*Isomeris arborea*.)

there remain a select few which we not only keep for their excellence but propagate for the purpose of exchanging with our friends. One of the plants we would not willingly part with is the Rock Tunica, *Tunica Saxifraga*, which though not at all showy has many good qualities to commend it. The plant is a native of the Alps and Pyrenees, but, unlike most truly Alpine things, it makes itself at home in almost any situation. We have it in the very light sandy soil of an open border, where it is not in the least injured by the heat of summer or the cold of winter. The habit of the plant is exceedingly neat; it has small, linear, bristle-like, stiff leaves of the size and shape of those shown in the engraving; its stems are prostrate and branching, and it forms cushion-like tufts of foliage a foot or more across and but a few inches high. From among the tufts of leaves arise the slender, much branched flower-stalks, which are about nine inches high, and bear a profusion of pinkish flowers of the size shown in the engraving. The individual flowers are in themselves not showy, but they are produced in such abundance upon flower-stalks that are so slender and thread-like that the flowers almost seem to be floating above the plant, and thus make it a noticeable and pleasing object in

pagate the plant by division, but it multiplies itself so freely by self-sown seeds that there is no need of taking the trouble. Late in summer or in early autumn seedlings will be found springing up around the plants by thousands, and we have only to prevent them from being hoed up as weeds to have as large a supply as we wish. The name *Tunica*, which means a coat, has reference to the small bracts which form an involucre around the calyx; the specific name *Saxifraga* indicates its resemblance in habit to some saxifrages. It belongs to the Pink Family.

A California Shrub—Isomeris.

Those who have visited the southern portion of California can not have failed to see a large shrub or small tree quite unlike anything they have known in the eastern states. It has a peculiarly sad-looking foliage of that grayish green color so common to plants in arid countries. The leaves being three-foliate would lead one to suppose that he had come across some relative of the clover, an idea that would be borne out by the pea-like pods. But an examination of the flowers would show that the

equal parts, and it was probably given for the reason that the stamens and petals are equal in length, while in related plants they are unequal. The leaves and all parts of the plant have a singularly heavy and unpleasant odor. The stem, which is often as large as one's arm, is yellow within, and the wood quite hard. Our correspondent, A. M. Gass, Esq., of San Diego Co., Cal., sent us some seeds last spring; these germinated readily, and during the season the plants reached the height of about two feet, and were flowering freely when the frost put a stop to them. Although this is a botanically interesting plant, and noticeable in its native localities, we can not commend it for cultivation as its other qualities do not compensate for its disagreeable odor. We figure it because of the frequency with which it has been sent from California for a name.

SAUCER PROPAGATION.—We have explained this several times, but correspondents still ask about it; one has some grape cuttings and wishes to know if he can start them by saucer propagation. No. This is only suited to very young, soft wood. A saucer of sand, kept constantly wet, has the cuttings of young shoots stuck in the sand and exposed to full sunlight.

THE HOUSEHOLD.

(For other Household Items, see "Basket" pages.)

About Earth-Closets.

Those who live in properly sewered cities give but little thought to the disposal of waste matter. Each house connects with the main sewer, and all offensive substances are carried off at once. In villages the accumulations of the household are usually deposited in vaults which are emptied yearly or less frequently, while upon farms it is very often the case that the provisions for getting rid of effete matter are often not only inadequate, but it is stating it mildly to say that the whole arrangement is a positive nuisance. It is more than a nuisance; it is often a crime. This is a subject that is not often discussed for the reason that it is not a pleasant one, but it is of so much importance that we can say that in many cases it is a matter of life and death. The great prevalence of typhoid fever in agricultural districts as compared with cities is traced directly to the general carelessness in disposing of that deposit which for the want of a better name we call "night-soil." That many privies are in dangerous proximity to wells is a fact so well established that we do not propose to discuss it here. A remarkable instance of the danger resulting from this state of things is cited in *Ogden Farm papers*, No. 46, in December last, page 449, to which our readers are referred. The object of the present article is not to show how privy vaults may be properly built and safely placed, but to impress upon the reader the fact that there is no need of the privy, as now used, at all. The health of the household is usually in the especial care of the mother, and here is one matter in which she can exercise her power for good in establishing an important reform—a reform not only of the greatest moment from a sanitary point of view, but one which will add much to the family comfort. It is a fact that any one who goes about with the senses of sight and smell ordinarily acute, finds it is the exception to come upon a farm privy which is not offensive to one or both of these senses—an evil that is crying loudly for a remedy. The amount of labor required to remedy this state of things is but little, and the expense almost nothing. We wish every one knew the virtues of dry earth, not dry sand, but good loamy earth, and the more clayey the soil the better. By *dry* we do not mean not positively wet, but absolutely dust dry. In summer this is easily secured by laying down a platform of old boards, scraping up the dry surface soil and throwing it upon the boards in a thin layer. It will become perfectly dry in a few days, when it may be sifted and be stored in a dry place for use. In spring this can not so readily be done, but take the driest earth that can be found, spread it on boards under a shed or in any covered place,

of the kind already referred to, and of assuring safety from all diseases communicated by human excrement. Those who have never tried it will be surprised to see how small a quantity of dried earth or coal ashes will render a deposit entirely inodorous. The main thing is to secure the absorbing material; the how of using it is of very little consequence so that each deposit is at once covered with it. Patented appliances are sold for letting a supply of earth or ashes upon the deposit in various ways. These are very excellent, and worth what they cost to those who can afford the expense.

the deposit. Figure 1 shows the commode closed, and figure 2 gives the same open. Figures 3 and 4 are sections showing the internal arrangement and the action when the cover is shut and open. The inventor describes the working of the apparatus as follows: "To feed the commode raise the lid *a* of the ash-box, which forms the cover of commode (or closet), and contains the screening apparatus, *c c*, and throw in the refuse just collected from under the fire grate; fasten down the lid tightly, and when you wish to use the commode raise the cover, as in fig. 4, the mere doing of which

causes a certain quantity of ashes to pass over the screen, the finer portions, *a d*, dropping through the screen, fall upon a shovel or distributor, *e*, and the cinders, *D*, roll over the screen down the sloping board *C*, and into the drawer *E*, to await removal for re-burning. After using the commode, pull down the cover (as in fig. 3), when the shovel *e*, before at the horizontal, now falls to the sloping position, throws the fine ash which rested upon it over the soil in the receptacle *f*. The partition of tin, *B*, when the cover was upright, held any fine ash that would otherwise have mixed with the unriddled again; but now throws it off, so that at the next use it will slide down

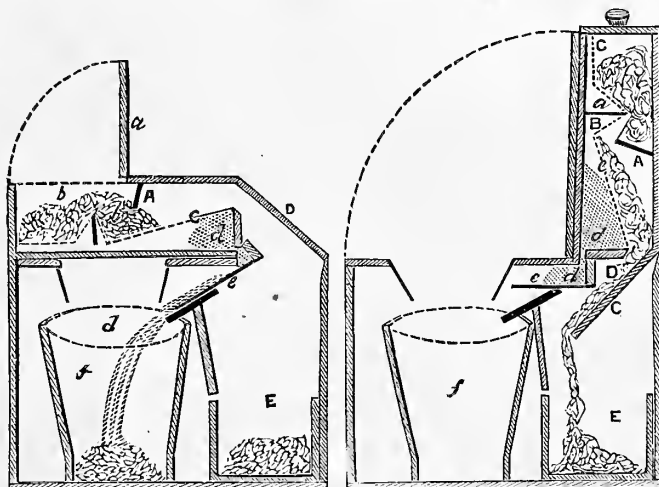

Fig. 3 and 4.—SECTIONS OF COMMODE.

The machinery is patented, but dry earth and coal ashes are not, and any one can contrive a box or other receptacle for the deposit, and have at hand a quantity of the earth or ashes with a convenient scoop, and accomplish the end without the aid of any machinery whatever. The end is to cover each deposit with the dry material, and if it is regularly done the privy will cease to be a nuisance. Existing buildings and vaults may be arranged for this—first, of course, removing all previous accumulations. Or a place may be arranged in any shed or out-building, and no matter how near the house it may be, if each person does his or her duty, it will be the cause of no offense whatever. But *note this*: no slops of any kind must be emptied into the receptacle of any earth-closet. If this be done the whole affair is ruined. While the earth-closet is a great blessing for general use, its inestimable value is shown when there is sickness in the house or where there are invalids or delicate persons who are unable to go out-doors. For house use there are commodes of various styles and by different makers, and all agree in the principle of throwing down a quantity of dry earth or coal ashes, though they accomplish the end by different mechanical means. We use the one first made in this country, by the Hartford Earth-Closet Co., and have had it some five years, during which time it has been entirely satisfactory. In the house the earth or ashes may be used by hand, the same as already mentioned, but, besides being more compact, it saves trouble from dust to have a closed apparatus of some kind. The different patented commodes are not very expensive, but one who is ingenious in such matters can readily contrive some affair that will answer the purpose. We recently saw in the *English Mechanic* engravings and description of a commode which was intended to both sift the ashes and apply it. We are not sure that this is advisable, but we give the illustrations more for the purpose of furnishing hints to those who would construct something of the kind than as a pattern to be followed. The inventor states that it is not patented, and does not conflict with any of the closets patented in England; how it may be with those in this country we can not say, but as there is no machinery about it we doubt if a thing like it has been patented here. In this closet or commode the cover is made large enough to receive the cinders as they come from the grate, and by the operations of lifting and shutting it the ashes are sifted out and at the same time made to fall upon

with the rest into the shovel. The wooden stage *A* acts in the same manner, and serves to measure the ashes that pass over the screen at each use. (See fig. 4 for the way in which it holds back the bulk of the ashes, *b b*, and fig 3 for the manner in which the measuring is done.)"

We can not too strongly commend 't' is matter to the careful consideration of every mother and father who reads these pages. We may add that the deposits from such closets may be used upon land, though their fertilizing value has been over-estimated. Still they are worth using on any farm crops. Remember that the earth must be *loam*, and *not sand*, and if ashes are used as an absorbent, they must be from *coal* and *not wood*.

What Shall we Have for Breakfast?

BY MRS. THOMAS S. ROBBE, NEW IPSWICH, N. Y.

- SUNDAY.—Fried oysters or clams; hot white rolls.
- MONDAY.—Broiled smoked halibut or salmon; baked potatoes; graham rolls.
- TUESDAY.—Beefsteak; fried potatoes, and milk toast.
- WEDNESDAY.—Fried sausage cakes; baked potatoes; corn rolls.
- THURSDAY.—Beef toast; buckwheat cakes.
- FRIDAY.—Mutton chops; baked potatoes; fried hominy.
- SATURDAY.—Fish balls; brown bread toast; bread fritters.

FRIED OYSTERS OR CLAMS.—They should be drained over-night. Dip them in pounded cracker crumbs and fry in hot fat. [These can only be had in perfection by those within easy communication with the coast, although in winter oysters go a long distance in good condition in sealed cans.—ED.]

SMOKED HALIBUT OR SALMON.—The fish should be put in soak the night previous. To avoid the disagreeable smoke which results from broiling on the top of the stove, it can be placed in a hot oven, on a bake-pau well buttered, and covered with another bake-pan. It will soon brown, and should have a little butter and pepper put on it before serving.

SAUSAGE CAKES are much nicer than the ordinary sausage, and are easily prepared. The meat being chopped and seasoned according to taste, it is made into little cakes, as fish-balls are made. They will

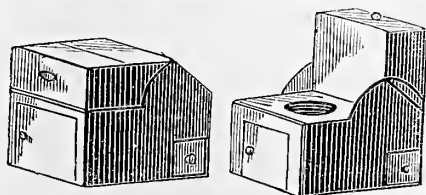

Fig. 1 and 2.—EARTH COMMODE.

and then thoroughly dry a small quantity at a time in a shallow box placed under or behind the kitchen stove or wherever else it may dry and not be in the way. Those who keep plants know to their sorrow how quickly earth will become dry if put where it can absorb no moisture. Any one who sets about it can get a sufficient supply of dry earth at any time when the ground is not frozen hard. Then the blessed discovery has been made that coal ashes—of hard or soft stone coal—are about equal to dry earth for sanitary purposes, and we may make ashes, formerly a nuisance to be got rid of, a blessing in the household. Secure a good supply of finely sifted dry earth or of coal, *not wood*, ashes, and you have the means of remedying all nuisances

keep a long while in a cold, dry place; but if a large quantity be made at once it is well to have it pressed hard into bags of strong cotton cloth.

BEEF TOAST is prepared by chopping fine the remnants of beefsteak or cold roast beef. It should be warmed up with a little water and seasoned with butter, salt, and pepper. Slices of bread should be toasted and laid on a platter on which the meat is to be turned when hot.

BREAD FRITTERS are made by soaking bread-crumbs in milk over-night. In the morning add an egg and salt and very little flour, as the thicker the batter is made by the crumbs the shorter and more delicious they are.

The lady who sends the above advises, as do the others, that all possible preparation for breakfast be made the night before.

Home Topics.

BY FAITH ROCHESTER.

MISTRESS AND MAID.—I can not wonder at all that refined American girls shrink from going out to service in families. But what girl who works for a living, as sewing girl or shop girl, would not find a happier lot in the kitchen of Mrs. Sin Saxton Scherman (see "Other Girls," by Mrs. Whitney), especially with such a work-fellow and room-mate as Bell Bree or Kate Seneerbox? Better still to be housemaid for Miss Louisa Alcott, the author of "Work." I read lately some of her experience with American help contributed by herself to the Boston Transcript. It is better than anything she can say in fiction upon the subject. I was especially delighted with the terms she made with the helpers she employed. If I had not sent away the paper containing the article I would venture to quote *verbatim*, although I know the editor would cut it out, as he insists on "original" matter—as if anything ever was original.

She frankly stated what sort of work she wished done; she wanted some one to work *with her* in the kitchen, taking at the same time the brunt of the labor. She wished an intelligent, respectable woman, who could make one of the family, sitting at the table with them, and reading their books and newspapers. She found just such companionship and help as she desired, in more than one case, and can not possibly supply all the applicants that now come to her for a situation, as she can not afford to give up her own share in the household gymnastics, so essential to her health.

I think the great secret of Miss Alcott's success with American helpers lies in the fact of her having outgrown, or having perhaps failed to inherit, the spirit of *caste* which mars nearly all human relations so far in history. Her helpers were never thought out of place in the parlor, though they were persons of sufficient refinement to leave the room when company called—just as you or I would do if boarding or visiting in Miss Alcott's family when visitors called to see other parties, unless we were invited to remain. Miss Alcott never hesitated to introduce her help to guests, when they fairly met, as "Miss So-and-so," not just "Jane," or "Mary." In short, she treated her help as one lady treats another lady. She paid no exorbitant wages, but gave the women who worked faithfully for her three dollars per week and a warm (*soul-warming*, I mean), comfortable home, where they were free to enjoy all the luxuries and refining influences of that home like its other inmates.

GETTING AWAY FROM THE CHILDREN.—When a baby is too young to reason with at all, it may be best to put on your bonnet in another room, and save it if possible from all thought of your absence until your return. But I have found it the best way usually to give the little ones an affectionate good-bye when I leave them for an hour or more. It is only treating them fairly, and they appreciate your confidence in them. Sometimes one will set up a cry to go too, when it is not a part of your plan to have its company; but you have only to refuse firmly—the more emphatically the louder it cries. It usually takes more than one lesson to teach a child that it can not conquer you by scream-

ing. Many children do gain their wishes in that way. Last summer I heard a child of four crying to go down town with her father. I heard him say petulantly more than once, "No, you can't go"! She only screamed the louder, and at the last moment he said, with the air of a vanquished man, "Well, get your bonnet and come along then." That child knows how to gain her point with her father, who regards her as a very willful child. A few weeks afterward the same little girl's mother came along past a group of children, and her own child skipped out to meet her. The mother had her hat under her shawl. She gave the little one some errand into the house, and then ran fast around the corner with the friend who accompanied her, saying to me, "I am going to meeting and I don't want her to go." The little one came out in a few moments and inquired for her mother. I called her to me and said, "Your mother has gone to meeting. She was afraid you would cry to go with her if she told you; but I am sure I can tell her when she comes home that you did not cry at all." She went back to her play without any complaint, and the mother seemed surprised when I told her about it next day.

FOOD FOR EXPECTANT AND NURSING MOTHERS.—I find many excellent things in a book called "The Philosophy of Eating," by A. J. Bellows, M.D., late professor of chemistry, physiology, and hygiene. To set a few thoughtless mothers to thinking, and to save their families from some sickness, and death perhaps, let me give the substance of a portion of the volume. He says in effect that the milk of the cow was intended to develop the calf, a work which it does perfectly; but if the calf were fed on cream alone or on butter it would very soon die. Butter can not develop a human being; and yet how many expectant and nursing mothers thoughtlessly provide themselves and their precious little ones with food largely consisting of superfine flour, butter, and sugar, without knowing or thinking that sugar and butter have no elements at all for muscles or bones or brains, and white flour very little.

Children, if their mothers fed exclusively on such food, would die within a month; and as it is, according to Dr. B., only one half in all Christendom and not one eighth in all Heathendom have vital power to carry them through the first five years. Those that live have a life of struggle with disease and suffering in just the proportion as they are deprived of food containing elements adapted to develop the whole system, and give power to resist and overcome disease. He states, what all thoughtful persons know, that most of our food contains an undue proportion of carbon. The butter, fine flour, and sugar which form so large a portion of our diet, consists largely of carbon, and this he considers renders all organs more susceptible to inflammatory and other diseases; while the deficiency of the nitrates and phosphates is another fault in such food. Animals in their natural state, living as they do according to natural laws, as a general thing raise all their young to full maturity. A physically perfect young man or woman, with perfect teeth and sound lungs and well-developed muscles and brains, is a rare exception to the general rule, and this he ascribes to improper food. Mothers' milk, if the mothers live on proper food, is the best as it is the natural food for children until teeth are formed, which indicates a condition that requires a change; but sickly mothers, those mothers who live on white bread and butter, would greatly benefit their children by weaning them and substituting the milk of the cow for their own poor product. The cow furnishes milk with too much nitrogenous matter. For this reason we, for young children, dilute it with water. As to other food than milk, that which will supply nourishment for the muscles and brain should be selected; but starch, arrowroot, sugar, and cream, all of which are sometimes given in ignorance of their character, contain no element of food but carbon; but, on the other hand, beefsteak and oatmeal, and such other articles as contain large proportions of nitrogenous and phosphatic elements, tend to develop the muscles and brain too rapidly; and a

special regard should be had to this consideration where the child is very active and precocious.

THE BREAKFAST QUESTION.—I am curious to see some of those best bills of fare sent in by the breakfast-getters of the *Agriculturist* constituency. I do not know whether they would help my case much. There are a good many difficulties in the way of solving this problem of a good early breakfast. First is the difficulty of waking up in time. Who wants to get out of bed and light a match to examine the clock on a cold winter morning? You lie waiting for it to strike, perhaps, and what if you have to count seven for your pains? Or you wait for a whole hour, and it strikes one, and by that time your blood is all in your head and your feet are cold. You have been writing articles for the press in the rare quiet of the hour—how clear the thoughts do come (and go!) just when there is no possibility of putting them on paper!—or you have the children's wardrobes all pulled to pieces about you, and can't sleep again until you see how they are all to be clothed for the coming season.

Then there is the fire to start. We have nothing to do on a winter morning but light the fire, all laid the night before in the kitchen stove, with the match and scrap of paper on the hearth.

The baby is always the unknown quantity in this problem. No one can tell at just what stage in the proceedings she will put in her claims for attention. If one woman has everything to do the time is a very busy and perplexing one.

I can not sleep comfortably if my mind is not made easy on the subject of breakfast materials before I go to rest. Steak to broil, potatoes all dressed for baking or boiling, plenty of bread in the house, coffee ready browned; that makes the problem not very difficult, especially if your husband, like mine, is ready to do a part—to broil the steak and make his own coffee, for instance, should any emergency arise such as is quite supposable where young children abound. Many nice things may be quickly prepared for an early breakfast if the preparation is begun the previous day; for instance, potato or fish-balls, meat, or meat and potato hashes, etc.

If warm bread must be made, graham gems take least time, provided your oven heats quickly. If the oven is hot when the raw gems go into it, you can take them out, done, in twenty or at most thirty minutes.

PROFESSOR BLOT CONCERNING BREAD.—We expect to find some directions about bread-making in our recipe-books. I turned to see what our celebrated cookery instructor would say, and found only this: "It is next to an impossibility to make good bread in a small family range or stove; four times out of five the bread is too much or not enough baked. Good baker's bread, besides saving a great deal of time and labor, is as cheap as you can make it at home." That is all! and it edifies me more than I can tell. But please tell us where to find our "good baker's bread."

That reminds me of a new recipe for yeast which I have just received from the best bread-maker I know of—my own sister. After all, perhaps I ought not to call her the "best bread-maker." The author of "The Philosophy of Eating" would call her very light, very white, very sweet bread, made of superfine flour mixed with new milk, poor stuff compared with almost any kind of graham bread, because superfine flour is such worthless stuff in his estimation. But if he saw the rye and Indian bread that always accompanies this beautiful white bread to the table he would feel better, for he highly commends rye and Indian bread. I hope sister will send me her recipe.

YEAST.—Two cups of grated potatoes; one half cup of sugar; one fourth cup of salt. Place these in a pan and pour over the mixture one quart of boiling water, stirring meanwhile. Place the whole on the stove and let it boil up once. When cool enough—about blood heat—add half a cup of good yeast. Set in a warm place to rise. It is very light and foamy, and does not sour readily. Like all soft yeast, keep it in a covered vessel as cool as possible without freezing.

BOYS & GIRLS' COLUMNS.

Some "Very Wonderful" Plants.

There are a great many curious things told about plants nowadays. Some plants shut up and droop their leaves when touched, and some time ago I told you about a plant that kept its leaves in constant motion whenever the weather was warm enough. Then there is the Venus's Fly-trap of North Carolina, that actually catches flies and other insects and appears to absorb their juices, or as we may say actually feed upon animal food. These stories about plants are very wonderful, and there are others quite as strange; but they are true, and any one who will take the trouble can see for himself that they are true. But our great-grandparents and their grand- parents were told stories about plants that were many times more wonderful than any that I have ever told you. When they were boys and girls, and were allowed to have a peep into the rare old books of their day—for children were not then of consequence enough for any Doctor



Fig. 1.—THE GOOSE-TREE.

Gray of the time to write about "How Plants Behave" for them, or any other Doctor to tell them about things in the *Agriculturist*; indeed they had no *Agriculturist*. People talk about the "good old times," but I think they must have been very stupid old times for boys and girls. Depend upon it, we live in the very best possible times. But we must not forget to tell about the wonderful things the boys and girls of the old times saw when they were allowed to look at the books. Just think of a "goose-tree"! Yes indeed, a tree which bore eggs for fruit, and which always grew conveniently near the water, so that when the fruit was ripe and broke open the little goose that was inside could fall into the water and swim away as nicely as could be. "You do not believe it?"—Well, here is the picture which plainly shows the whole thing. Yes, as strange as it may seem, this story of the way in which some kinds of water-fowl were produced was believed not by ignorant people alone, but the men of two and three centuries ago who were considered the most learned of their time gave full and minute accounts of the matter, describing the tree, egg, and bird, and even claiming to have seen the young bird within the egg. I know of three different books, each of which has an engraving showing the same thing each in a different way. You wonder how these people could have been so deceived; but you must recollect that in those early days

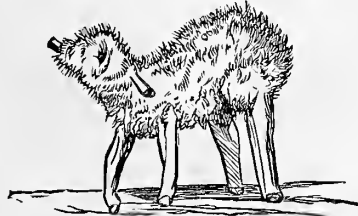

Fig. 2.—THE TARTARIAN LAMB.

there was much less known about plants and animals than at present. Many a bright boy and girl who reads this really knows more about geography than Columbus did, and so with other things our young people know better how to use their eyes than did even the learned doctors of the old times. It is believed that this whole story grew out of the fact that there is a salt-water animal, a kind of barnacle, which has a white shell-like covering that is shaped something like an egg, and is perhaps as large as a robin's egg. Each of these has a sort of stem, twice as long as itself, by which it is attached to a piece of wood or any other support. The animal within this shell has curious feelers, shaped something like a

hand with many long and delicate fingers. This barnacle seems to be the foundation of the whole story. Those who saw that the shell contained something alive did not use their eyes and examine the matter carefully, but took the fishermen's stories about their hatching out birds to be true. Quite as absurd is the "traveler's tale" of the Tartarian Lamb, a most curious thing which was part plant and part animal.

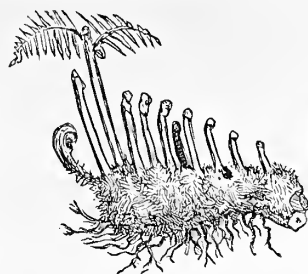

Fig. 3.—A FERN ROOT.

According to the story, this lamb grew upon a stem about three feet high, which was attached to it at the belly. When the little lamb wished to feed, all it had to do was to bend the stem over until it could graze away at the grass all around it. This was a very pretty arrangement, as when satisfied with eating it had only to rock and dandle away upon its stem, a thing that the lambs of the present day are unable to enjoy. To be sure the contrivance had its disadvantages, for when all the grass within reach had been eaten up the poor little thing could only "up and die," and how any seed was preserved for the next year's crop the few travelers who had seen the plant fail to state. As the Tartarian lamb was only found in the far-off desolate plains of the Volga, it was a long time before the real truth of the matter could be made out. If you would like to know what the little lamb was like, here is a picture (figure 2) of one from a drawing made of a specimen in the British Museum. Its fleece was got "as white as snow," like the celebrated one that "Mary had," but was yellow, and it does not look much as if, like Mary's lamb, it was "sure to go." Like the goose-tree, this lamb plant when properly examined turns out to be a very simple affair. The underground stems of some of our native ferns look very much

like the one shown in figure 3. Perhaps some of you have seen in a plowed clearing fern stems that are a good deal like the figure—I have, hundreds of them—as they are a long while in decaying. This stem grows along underground, and the leaves come up from it year after year. This Tartarian lamb was made from a similar fern stem, which is, as some of them are, clothed with long, coarse hairs. When all but four of the leaf stalks are cut away, and the thing turned upside down, it can, with a little trimming, be made into a good enough lamb to serve as a foundation for the story. If those travelers who brought home the tale of this wonderful lamb had been taught to use their eyes properly when they were young they would not have been deceived by such a stupid trick—at least so thinks

THE DOCTOR.

A Strange Bird.

You perhaps think that the bird in the picture is not a beauty, but no doubt its mother thought it one of the dearest little chicks that ever came out of a shell. It is said, you know, that "every crow thinks her own young the whitest," and it is likely that this fondness for one's own was shared by the mother Dodo. Yes, Dodo is its name—don't call it doodo, it should sound like "so-so."—Its scientific name is *Didus*, but you had better stick to Dodo, for fear you should get the names mixed and say "dido," which every youngster knows is a very bad thing to "cut up." Why do we tell you about the Dodo? certainly not on account of its good looks; but it is very interesting for a reason that we will try to show. You are aware that in some places, especially on the Connecticut river, the rocks show the footprints of enormous birds. These birds trod upon the sand and, being heavy, made a deep track; the water brought down more sand and filled up these tracks, and after many years the sand became hardened into sandstone, and those who get out the sandstone to build brown-stone houses, every now and then came across these enormous foot-prints, made longer ago than any of us can think. Then again in some parts of the country there are found the bones of huge birds, which were much larger and different from any living birds; yes, even the bones of birds with teeth were found last year. All this goes to show that at one time there were birds (as well as other animals) quite different from any that are to be seen now, and all that we know about them is what can

be learned from their bones, or fossils as they are called. In the island of Mauritius there are bones of a very large bird, but the bird itself is not to be found. Unlike the birds that were just spoken of as having lived so long ago, this bird of the Mauritius was known to be living less than 200 years ago. It was discovered by the Portuguese sailors but a few years after the famous voyage of Columbus, and was later taken to Europe, where its portrait was painted several times, and it was described by several writers. A head and a foot saved from a stuffed specimen are yet in the British Museum. There is every reason to believe that this bird, not an individual of which is known to be living now, and which we can only know from its bones, was quite at home on the island of Mauritius, and so abundant that the sailors used to catch them for food, though they found them rather tough eating. Here we have a case in which a bird, now found only as a fossil, has lived until very recent times, and that makes the bird a very interesting one, and helps us to see in our imagination a few ages back, when the huge Shanghai-like creatures took their walks along the sandy shores of the Connecticut valley. The name Dodo was probably given by the Dutch sailors. Five paintings of the bird were known to be in different galleries and museums in Europe, and a few years ago a sixth was discovered, which has recently been figured in the London Field, from which we borrow the picture. The bird has evidently some unpleasant thing sticking to its bill from which it is trying to remove it by the use of its claw. The Dodo was evidently not a very swift bird; the naked part of its leg was as big around as it was long; it could not fly as it had no wings to speak of; its body was covered all over with a mouse-colored down and it had for a tail and wings a few long feathers; it weighed about 50 pounds. Naturalists have been puzzled to know in what family of birds the Dodo belongs, but they now consider it to be most nearly related to the pigeons than to any others. What nice pets a coop full of pigeons like this would be, and what a lot of corn such a bill would devour!

Aunt Sue's Puzzle-Box.

NUMERICAL ENIGMA.

I am composed of fourteen letters.
My 9, 7, 12, 10 is to suffer.
My 1, 2, 3, 11 is an article of dress.
My 6, 4, 5, 8 is the outer part.
My 13, 14, 2, 6, 11 is a building.
My whole is the familiar name of a bird. **KATIE.**

HIDDEN COUNTIES.

- Oh! Ed, get off, or don't kick so.
- Smith's cottage was burnt last spring.
- I was surprised to see that fop open the door.



THE DODO'S PORTRAIT.

- Indeed, Sal, I need a new book.
- I am glad to hear that the lost ark was found.
- She works hard in the shop all day.
- The meal was as bitter as gall at Indiana.

JESSIE MAY FLOWER.

PI.

Fi ouy swih ot eb pahyp foulresy virstet ot kame sertho-
hyppa. **MARY A. H.**

DIAMOND PUZZLE.

The center letters, perpendicular and horizontal, name one of Shakspeare's characters.

1. A consonant.
2. A quadruped.
3. Trials of speed.
4. A name.
5. Sediment.
6. Eaten.
7. Two hundred.

WILLIAM P. AND EDWIN H. ALBRIGHT.

ANSWERS TO PUZZLES IN THE FEBRUARY NUMBER.

NUMERICAL ENIGMAS.—1. Be just, and fear not.

2. Autumn leaves.
- Cross-Words.—1. Laura. 2. Samuel.

ALPHABETICAL ARITHMETIC.—

1809)386650280(213737 Key: "Reckon fast."

SQUARE-WORD. O J U D D
J O K E R
U K A S E
D E S K S
D R E S S

The First Lesson in Rowing.

Can you swim? Yes, Miss, we mean you as well as your brother. We believe that both boys and girls should be taught to swim. Boys generally, if they live near the water, learn to swim without much teaching. If they can swim, then they can learn to row, for we do not think that a boy should be trusted in a boat unless he is able to take care of himself if he should happen to get overboard. It is not only useful to know how to row, but rowing is most capital exercise. It calls a great num-



TAKING HIS FIRST LESSON IN ROWING.—Drawn and Engraved for the American Agriculturist.

CROSS-WORD.

- My first is in tact but not in skill.
 - My next is in dose but not in pill.
 - My third is in noun but not in verb.
 - My fourth is in spice but not in herb.
 - My fifth is in part but not in whole.
 - My sixth is in heart but not in soul.
 - My seventh is in won't but not in will.
 - My eighth is in note but not in bill.
 - My ninth is in pink but not in blue.
 - My tenth is in one but not in two.
 - My eleventh is in knoll but not in hedge.
 - My twelfth is in pin but not in wedge.
 - My thirteenth is in blue but not in pink.
 - My fourteenth is in speak but not in think.
 - My whole is a city of well-known fame:
- Study the letters and tell its name.

JA-SE-PE-ES.

ALPHABETICAL ARITHMETIC.

O L A) C R H B E K S (H O L A
C A A R

K L A E
K E H B

B H S K
B C C H

L C S S
L B H S

A A E
BLANKS.

(Fill the blanks with words pronounced alike but spelled differently.)

1. He was ordered to — out the — of the church.
2. The — does not grow on the island of —.
3. Will you — a — of apples for the child?
4. The — was a man of mean —.
5. I am afraid this — will not agree with the young —.
6. The child began to — for the —.

ITALIAN BOY.

HIDDEN NAMES OF ANCIENT GRECIAN DEITIES.—

1. Venus. 2. Castor. 3. Saturn. 4. Cybele. 5. Doris. 6. Oceanus.

ORNITHOLOGICAL AMPUTATIONS.—1. Powter, tower. 2. Plover, lover. 3. Snipe, pine. 4. Ortyx, Tory.

All contributions for the PUZZLE-BOX should be addressed to "AUNT SUE," Box 111, P. O., Brooklyn, N. Y.

AUNT SUE'S NOTICES TO CORRESPONDENTS.

HANNAH R.—Thanks for your "contribution," but as it may be found in most of the unabridged dictionaries it is scarcely worth our while to publish it.

Thanks for answers, letters, etc., to O. A. Gage, Miles P. J., Mary C. S., Maggie Cator, J. E. Frahm, W. H. S. F., James H. G., and Mamie W.

A Corresponding Society.—

One of our boys writes that he thinks that a corresponding society might be formed among the farmers' boys which would result in great benefit to its members, and sends us a notice calling for the addresses of those who wish to become members and asks us to publish it. This is a question to which there are two sides, and we hope that "O. F." will not think us unkind if we decline to publish his call. In the first place he takes no measures to satisfy us that there is such a person as "O. F.," and we do not know—although we do not think it—but it is a dodge of some one to get the addresses of hoys all over the country. Secondly, we do not think such a proposition would meet the approval of parents in general. We should not wish a son to be in correspondence with a circle of boys of whom we know nothing whatever. A forced correspondence of this kind is not likely to result in much good. If "O. F." is desirous of improving himself let him get together half-a-dozen or more boys in his own neighborhood and form a young Farmers' Club. He will find it of much more use than a wide-spread correspondence with strangers you never have seen.

ber of muscles into play, and not only exercises the arms, but the chest and, in fact, the whole body. Rowing is now very popular with college students, and crews from a number of the leading colleges have a yearly rowing match, which is the occasion of much excitement. They carry a good thing too far, but even that is better than horse-racing. The boy is fortunate if he, like the one in the picture, has an "old salt" for a friend, who will teach him how to handle the oars. Of course great skill can only be had by practice, but you can get along much faster with a little showing. It is amusing to see what work those make who are unused to rowing; they lay out a great deal of strength to little purpose, and get more tired in fifteen or twenty minutes than a regular oarsman would in all day. Some men who live in the lake regions make nothing of rowing twenty miles or more from one point to another. The boy in the picture has "caught a crab." Perhaps you don't know what that means. When one misses a stroke and instead of pulling his oar against the water pulls it against the air he is very apt to lose his balance and tumble over, and this is what sailors and water-men call "catching a crab."

Writing for the Paper.—

A number of boys and girls have written us articles that they wish us to print. Now, we are always glad to hear from any boy or girl of our large family; you may be sure of that. But we must be the judge as to the printing. There are but few very young people who can write what other young people would care to read. It might please the writers to see what they have written in print, but we do not often get an article from boys and girls that we think should be printed. "But should we not try?" Of course you should, and the very first one who writes what we think the rest would be pleased to see will have the article appear in the paper. You who can not yet spell all the words correctly must not think of writing for the paper. First learn to write a plain and neat hand without making a single mistake in spelling; the time will be much more usefully employed than in writing things that you hope may be printed.

Life Insurance.

THE large majority of men do not accumulate. They live in the present. They take care of to-day's wants with to-day's means. They use their capital, forgetful that it may at any time be made unavailable by disease or accident, or swept away entirely by death; forgetful also that, as the years roll on and the palsy of age steals over them, that capital which they have in life and health will gradually diminish and its incoming interest grow less.

These considerations, to the man who has only himself to care for, are but trifling. He knows that so long as he is able to work he will be provided for, and that when death comes he will receive the last offices of the living—whether kind and loving or merely formal matters little to him. But he who has a family should bethink himself that he liveth not unto himself alone; that he owes a duty to those who are dependent upon him. Of the capital which he has in his strong arms and his trained intellect, only so much belongs to himself as is necessary, by its use, to provide himself with the means of living, and that which remains belongs to those whose natural protector he is. He has no right, if he can in any way guard against the contingency, to deprive them of their rightful share of the capital. He may guard against that contingency, if he shall live long enough, by saving his surplus till it shall reach a sum sufficient for their support. It is well—nay, it is his duty—to do this. But in the way of its accomplishment stands that ominous "if." To-day he is strong, capable, with a long life apparently before him. His capital and that of his wife and children is to all appearance as secure as though it stood in United States bonds. To-morrow the skeleton hand of the grim messenger reaches for him, and his strength is impotent, his skill is naught. The man's capital is dissipated! To himself this is nothing, for he has no earthly wants to be supplied; but to his family his death is utter bankruptcy. For them "the strong staff is broken," and they are helpless.

Just here the beneficence of life insurance is made to appear. By accepting the offer held out by the United States Life Insurance Co. of this city, the man whose capital is all in himself may continue that capital for the use of his dear ones. There is no other investment so safe as this, and none more profitable. The Company has proved its stability through the most eventful quarter of a century in the history of this country. Its plans are liberal; its management honest and capable; and its security beyond doubt.

The Best Water Pipe,

also the cheapest, when strength and durability are considered, is the **TIN-LINED LEAD PIPE**, made by the **COLWELL LEAD CO.**, No. 213 Centre St., New York. Price 16½ cents a pound. Descriptive Pamphlets sent by mail free.

S. B. Parsons & Sons offer at Flushing, N. Y., Rhododendrons and other Trees and Plants at less than cost of importation.

HOWARD & CO.'S

Advertisement of

Waltham Watches.

A catalogue of all the grades of genuine Waltham Watches, with prices, will be mailed free to any one who writes to Howard & Co., No. 223 Fifth Ave., New York. Watches ordered from it will be sent by express for examination to any part of the country. Gold and Silver Watches only. ALL warranted. LOW prices and no risk. SEND FOR THE BOOK and judge for yourself.

When you write, say advertisement seen in "Am. Agriculturist."

Mutilated National Bank Notes and U. S. notes bought—one (1) per cent discount. Two (2) per cent premium paid for broken National Bank Notes. DE HAVEN & TOWNSEND, 40 S. 3d St., Philadelphia, Pa.

MONEY MADE RAPIDLY with Stencil and Key Check Outfits. Catalogues and full particulars free. S. M. Spencer, 117 Hanover St., Boston, Mass.

BANKING & FINANCIAL.

BANKING-HOUSE OF FISK & HATCH.
No. 5 NASSAU ST., NEW YORK.

We buy and sell GOVERNMENT BONDS and GOLD at current market rates; buy Gold Coupons; buy and sell Stocks and Bonds at the Stock Exchange on Commission, for cash; receive Deposits and allow Interest at the rate of four per cent; make Collections, and transact a general Banking and Financial business.

We also deal in the **CENTRAL PACIFIC** and **WESTERN PACIFIC GOLD BONDS**, which, at present prices, are very desirable for investment.

We are also selling the **CENTRAL PACIFIC GOLD SIX PER CENT LAND BONDS** at 85 and accrued interest.

FISK & HATCH.



The finest and richest chromo ever sent out by any editor as a premium. It is no "cheap daub" or "meaningless picture," as is proved by the unanimous verdict of all to whom it has been sent.

JOHN J. THOMAS, Union Springs, N. Y., writes: "The common practice of offering Chromos to subscribers has nearly had its day—third rate ones being chosen for the purpose because they can not be otherwise disposed of. This one, however, is a very different thing—good as a work of art, and brilliant and refreshing as a picture. The fine display of fruit which it represents makes it very appropriate for the readers of the *Fruit Recorder*, and I think all will be pleased with it."

From JAMES VICK, Rochester, N. Y.:—"FRIEND PURDY: Accept my thanks for your pretty Fruit Chromo. It is well executed, and will be appreciated by all lovers of fruits and paintings. Next year, suppose you give us a Chromo of popular Small Fruits, in which you take so much interest."

From J. B. ROOT, Rockford, Ill.: "We shall hereafter have choice fruit in the house the year round, for your Chromo is fully equal to nature—one of the finest pieces for the drawing-room I ever saw."

We have similar testimonials from such men as T. G. Yeomans, Thos. Moolan, Ellwanger & Barry, William Barry, T. C. Maxwell, and hundreds of other subscribers who have received it—most of them going into ecstasies over it. Out of the twelve thousand we have now sent the Chromo to we have not received a single complaint. We doubt if this can be said of many chromos sent out as premiums. We offer to refund the money and stop the paper if any are dissatisfied with the Chromo or paper and will return them to us. We have the entire control of this magnificent fruit picture, and it can only be had by subscribing for

"The Fruit Recorder & Cottage Gardener" for 1874, a monthly, at \$1.00 per year, or \$1.25 with the Chromo. Specimen copies of the paper sent free to all applicants. A single copy will satisfy any one as to its being the most practical paper printed on this continent for the fruit grower, flower fancier, and market gardener. Club agents say they have found nothing like it and Chromo to work with, and that no publisher offers more liberal inducements. All necessary papers sent to such as desire to work for clubs on application. We also send out a book of 64 pages, called "The Small Fruit Instructor," which tells in a plain, common-sense way just how to grow small fruits in abundance for family use and market. Price, post-paid, 25 cents. Address

A. M. PURDY, Palmyra, N. Y.

Send for The PIONEER.

I hear the tread of pioneers
Of nations yet to be;
The first low wash of waves where soon
Shall roll a humau sea.

A handsome illustrated paper, with information for the PEOPLE, mailed free to all applicants. Address

O. F. DAVIS,
Land Commissioner U. P. R.R.,
OMAHA, NEB.

Farm for Sale. Rare Chance

to buy a farm under good cultivation, 100 acres; well watered; suitable for stock-breeding, dairy, or tobacco. Good buildings, 15 miles from Harford; 2 miles from R.R. station; 1½ miles from six churches, good schools, and markets. Address

WM. R. HURD, Forestville, Ct.

(CIRCULAR.)

Consumers Importing Tea Co.,
No. 8 Church Street,
P. O. Box 5,509. New York City.

This is a combination of capitalists to supply the consumers of Teas throughout the United States on the mutual principle.

We have experienced agents in all the best districts of China and Japan to select Teas especially for our trade.

We expect every consumer of Teas to render us all the assistance they can in carrying out our enterprise, as we make a specialty of SUPPLYING CONSUMERS ONLY (and allow no middlemen to make any profit on our importations), which will enable us to supply them with Teas at prices lower than have ever been known, and of those fine qualities that seldom reach the interior, being sold only in the large cities and among the very wealthy.

Hoping the consumer will take an interest in our enterprise, and send at once for a circular with full explanations of how to proceed to obtain our goods, we remain,

Most respectfully yours,

Consumers Importing Tea Co.,

No. 8 Church Street,
P. O. Box 5,509. New York City.

Entered, according to Act of Congress, in January, 1874, by the Consumers Importing Tea Co., in the Office of the Librarian of Congress, Washington, D. C.

GREAT DEDUCTION.
TEAS and COFFEES

At Wholesale Prices.

Increased Facilities to Club Organizers.
Send for New Price-List.

THE GREAT AMERICAN TEA COMPANY,
(P. O. Box 5643.) 31 and 33 Vesey St., New York.

GEO. A. PRINCE & CO.

ORGANS & MELODEONS.

The Oldest, Largest, and Most Perfect Manufactory in the United States.

53,000

Now in use.

No other Musical Instrument ever obtained the same popularity.

Send for Price-Lists.

Address

BUFFALO, N. Y.

"The Best Article in the Market."—*Am. Institute Report*, 1873.



H. W. JOHNS, 87 Maiden Lane, N. Y.
Patentee and Sole Manufacturer. Established 1858.

Beckwith Sewing Machine Co.

Will exchange their \$20 PORTABLE FAMILY SEWING MACHINE for their \$10 and \$12 machines, and allow for the same when returned their retail price less \$2, to apply in part payment of one new \$20 machine. Send for Circular and samples. Address

862 Broadway, New York.

ROSES BY MAIL—6 plants for \$1.00; \$9.00 per 100. See Advertisement, page 152.
R. B. PARSONS & CO., Flushing, N. Y.

W. A. COVERT & CO., Produce
Commission Merchants, No. 63 Pearl Street, New York. "Quick sales and prompt returns." Send for our weekly Prices-current and Marking Plate.

NEW POTATOES.

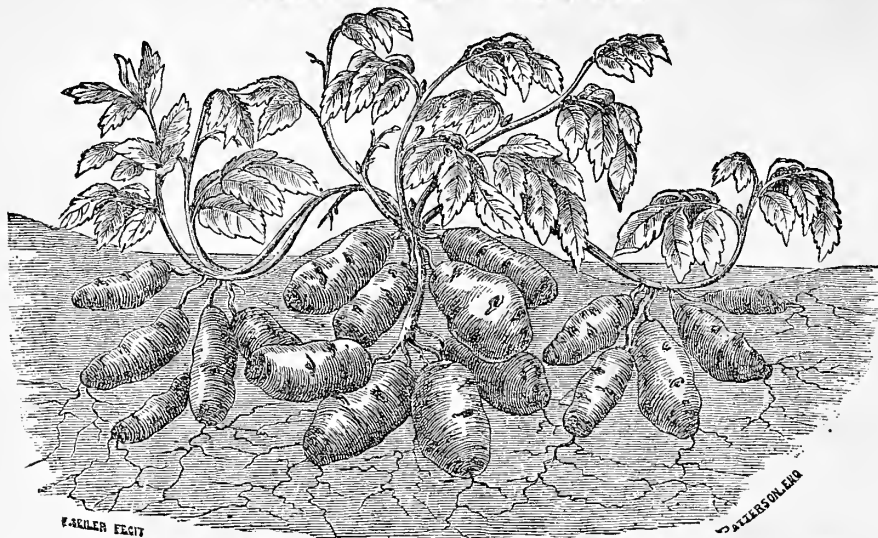

COMPTON'S SURPRISE.

Showing the product from a single eye in the grounds of F. SEILER, Veroua, N. Y., who raised 384 pounds from one pound of seed.

To the two popular varieties, **Extra Early Vermont** and **Compton's Surprise**, introduced by us last Spring, we take pleasure in adding two new varieties, **Snowflake** and **Brownell's Beauty**, as medium sorts maturing between the two, their equal in quality and productiveness—and the most beautiful varieties in cultivation. The great popularity of the **Early Rose**, **Peerless**, and others of Breese's seedlings first offered by us, and their general adaptation to the various soils and climates of the civilized world, have induced thousands in all parts of the country to experiment in raising seedlings, in hope of producing a better one, a large number of which have been sent to us for trial. After being carefully tested by ourselves as well as several of the most experienced cultivators in the country, the above named varieties have been selected, which we offer to our patrons, fully confident of their superiority.

In addition to the many valuable testimonials received from growers of the above varieties in our own country, the following favorable note is received from Dr. Masters, the talented and well-known editor of the **London Gardeners' Chronicle**, which shows the high estimation in which **Brownell's Beauty** and **Extra Early Vermont** are held in England:

GARDENERS' CHRONICLE AND AGRICULTURAL GAZETTE }
OFFICE, London, England, October 7, 1873.
GENTLEMEN: Last year you were good enough to send us for trial some of your new kinds of Potatoes. As a large trial of over 300 sorts was projected to be carried out at the

Royal Horticultural Society Garden, at Chiswick, this season, I thought the fairest way would be to send your samples to be tried with the rest. I sent them under numbers, so that no one but myself knew either the names of the varieties or the senders. I have now the pleasure of telling you that a **First Class Certificate** was awarded by the judges to your **Extra Early Vermont** and to **Brownell's Beauty**. No doubt you will obtain official notice of this ere long; meanwhile I thought you would like to know how much appreciated your potatoes were.

I am, gentlemen, your obedient servant,
(Signed), MAXWELL T. MASTERS.
To B. K. BLISS & SONS, New York.

Prices for **Brownell's Beauty** and **Compton's Surprise**.—
Per lb., \$1; 3 lbs. to one address, \$2, by mail, prepaid.
By express or freight, charges paid by the purchaser,
1/2 peck \$3; 1 peck, \$5; 1/2 bushel, \$8; 1 bushel, \$15;
1 barrel, \$30.

EXTRA EARLY VERMONT.—By mail, prepaid, 1 pound, 75 cents; 3 pounds, \$1. By express, charges paid by purchaser, 1 peck, \$3; 1/2 bushel, \$5; bushel, \$9; barrel, \$20.
SNOWFLAKE—by mail, prepaid, \$3 per pound.

For full description of each of the above varieties, see our **Illustrated Potato Catalogue**, which will be mailed free to all applicants.

\$1,500 IN PREMIUMS.

IMPORTANT TO POTATO GROWERS.

\$750.00 to be divided among the six successful competitors who shall produce the largest quantity of either of the following varieties of Potatoes: **EXTRA EARLY VERMONT**, **BROWNELL'S BEAUTY**, or **COMPTON'S SURPRISE**, from one-quarter of an acre of measured ground. \$250 for each variety.

\$750.00 to be divided among the six successful competitors who shall produce the largest quantity from ONE POUND of the seed of either of the above named varieties. \$250 for each variety. Subject to conditions named in our Potato Catalogue, a copy of which will be mailed to all applicants.

THE SEED IN ALL CASES TO BE PURCHASED FROM US.

BLISS'S GARDENERS' ALMANAC AND ABRIDGED CATALOGUE,

One Hundred pages, illustrated. Mailed to all applicants including two three-cent stamps.

Bliss's **Illustrated Catalogue and Guide to the Flower and Kitchen Garden**, 200 pages several hundred illustrations, with a beautiful colored lithograph. Mailed to all applicants upon receipt of 25c. Address

B. K. BLISS & SONS,

P. O. Box 5712.

23 Park Place and 20 Murray St., New York.

Seed Potatoes a Speciality.

Vermont Early Rose,

PEERLESS, WHITE PEACH-BLOWS, and other varieties, in fine order, selected especially for planting. Prices reasonable. Order of TATEM & DAVENPORT, No. 1 Delaware Avenue Market, Philadelphia.

SEED AND POTATOES by mail, post-paid. Lane's Improved Imperial Sugar Beet. The best to raise for stock. Yields, with good culture, from 25 to 30 tons per acre. Seed—1 oz., 15c.; 1/4 lb., 40c.; 1/2 lb., 70c.; 1 lb., \$1.25; 4 lbs., \$1.50. Potatoes—**Early Vermont**—Earliest Potato Known. 1 lb., 50c.; 4 lbs., \$1.50. **Compton's Surprise**—(I raised 369 1/2 lbs. from 1 lb.) 1 lb., 75c.; 4 lbs., \$2.50.
DAVID R. WOOD, Morrisville, Lamolle Co., Vt.

CHOICE SEEDS.

Market Gardener's Stock FOR EARLY PLANTING.

Fottler's Brunswick Cabbage.....Per oz., 75c. Per pkt., 15c.
True Jersey Wakefield do..... " 75c. " 15c.
Boston Market Dwarf Celery..... " 50c. " 10c.
" Hotbed Lettuce..... " 50c. " 10c.
White Spined Hotbed Cucumber.. " 50c. " 10c.

Our new Seed Catalogue for 1874 will be ready February 1st. Free to all applicants.
Address SCHLEGEL, EVERETT & CO.,
16 South Market St., Boston, Mass.

HUBBARD SQUASH SEED.

Strictly pure. Grown 1 m. from anything that would mix. 19c. per pkt., post-paid.
ALONZO HITCHCOCK, Concord, Dodge Co., Minn.

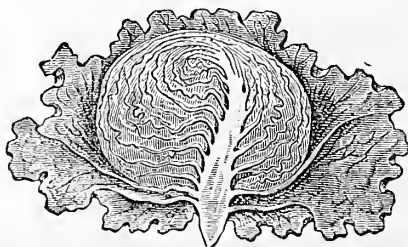

The HANSON LETTUCE.

The most tender, sweet, and delicious variety grown; free from any bitter or unpleasant taste; heads large and solid, often weighing 3 lbs. **Single pkg 25 cts. 5 pkgs \$1. A LIBERAL DISCOUNT TO DEALERS.** Send for Dreer's Garden Calendar for 1874, 168 pages, illustrated, with practical directions. Mailed FREE to all applicants.
HENRY A. DREER,
714 Chestnut St., Philadelphia, Pa.



Our Annual Spring Catalogue of Flower and Vegetable Seeds is now ready. Free to all on application.

Seed Time Cometh!

The twenty-first editions of our illustrated **FLOWER and KITCHEN GARDEN DIRECTORIES** for 1874, with a Supplement of Novelties and Selections, embracing a list of Seed grown by the best Boston Market Gardeners and also by the most famous European growers of flowers and vegetables, including many that can rarely be found elsewhere, will be forwarded about the first of February to all customers free of charge, and to other applicants enclosing a three-cent stamp.

D. T. CURTIS & CO.,
161 Tremont St., Boston, Mass.

Successors to CURTIS & COBB.

SEED FOR EARLY FORCING.

TOMATO, *New Early Dwarf*, fine for small gardens—
3/4 pkt. 25c.

TOMATO, *Canada Victor*, a superior productive early var.—
3/4 pkt. 15c.

TOMATO, *The Arlington*, bright red, solid, and fine form—
per pkt. 25c.

Boston Market Tennis Ball Lettuce—3/4 oz. 75c.; 15c. 3/4 pkt.

White Spined Cucumber, improved—50c.; 15c. 3/4 pkt.

Long Frame Cucumbers, High'd Mary and Hallstone, each
25c. per pkt.

Fresh & Genuine Wethersfield (Ct.) ONION SEED.

By mail, post-paid, at following rates:

	Per lb.	Per oz.
Wethersfield Large Red—true.....	\$3.00	.20
Medium Early Thick Red.....	3.50	.25
Extra Early Red—very early.....	3.75	.30
Yellow Danvers—true.....	3.50	.25
White Fortugal or Silver Skin.....	4.00	.30
White Globe—extra fine.....	5.00	.40
Fottler's Imp. Ely Brunswick Cabbage—true.	13.00	1.00
Comstock's Pre. Flat Dutch.....	4.00	.30
Comstock's Seed Sower and Onion Weeder combined, by express, \$15.33.		

I would again call the attention of gardeners and others to the great superiority of our *true Wethersfield grown Onion*, as well as other seeds, and urge upon them the importance of procuring reliable seed.

Catalogues sent free to all.
R. D. HAWLEY, Seedsman, Hartford, Conn.



My business is to supply, what every farmer of experience is most anxious to get, *perfectly reliable* Vegetable and Flower Seed. With this object in view, besides importing many varieties from reliable growers in France, England, and Germany, I grow a hundred and fifty kinds of vegetable seed on my four seed farms, right under my own eye. Around all of these I throw the protection of the three warrants of my Catalogue. *Of new vegetables I make a specialty*, having been the first to introduce the Hubbard and Marblehead Squashes, the Marblehead Cabbages, and a score of others. My Catalogue, containing numerous fine engravings, taken from photographs, sent free to all.

JAMES J. H. GREGORY, Marblehead, Mass.



New & Rare Plants.

Our Illustrated Catalogue of Plants for 1874

is now ready, and will be sent free to all our customers, and to all others on the receipt of two 3-cent stamps.

HOVEY & CO., 53 North Market St., Boston.

SEEDS! SEEDS! SEEDS!

Spooner's Prize Flower Seeds; 12 varieties Splendid Aster Seeds mailed to applicants upon receipt of \$1.00. New Illustrated Seed Catalogue free. Address Wm. H. SPOONER, 4 Beacon St., Boston.



4 STYLES, One just out. The Seeders and Cultivators, for Farm or Garden. Light and durable. No equal, Domestic or Imported. Descriptive Circulars of S. L. ALLEN & CO., 119 S. 4th St., Phila., Pa.

Early Jersey Wakefield Cabbage	100.	1,000.
Plants—fall sown.....	\$.75	\$6.00
Celery Plants—Boston Market and Sealey's		
Levithian.....	.75	6.00
Tomato Plants—Canada Victor.....	3.00	
Extra select Trophy.....	1.50	10.00
Lettuce—Boston M'k and Simpson, fall sown	.50	4.00
Massey's Winter Head (best frame		
Lettuce).....	2.00	15.00
Hanson.....	2.50	
Egg-Plants—Improved New York, per		
doz., \$1.00.....	5.00	
Sweet-Potato Plants—Southern Queen		
and Yellow Nansemond.....	.30	2.50
Asparagus—Conover's Colossal, 2 yrs., Ex-		
tra line.....	1.00	6.00
Cabbage Plants—In July, Drumhead, Win-		
ngstad, Savoy, Flat Dutch, and Bruns-		
wick.....	.50	2.50

If to be sent by mail add \$1.00 per 100. Correspondence solicited with those who plant largely.

MASSEY & HUDSON,
Chestertown, Kent Co., Md.

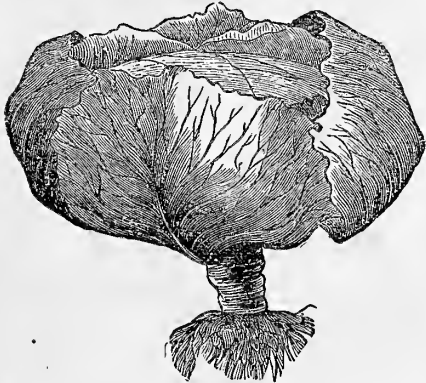

Marblehead Mammoth!

You will find in my Seed Catalogue letters from a score of people who, by following the directions sent with every package of seed, have raised this Cabbage to weigh from 30 to 60 lbs. a single head! I was the original introducer of this giant Cabbage, and my seed is all grown from heads that are extra large and very solid. Sent post-paid by me, 25 cts. per package; \$1 per ounce; \$10 per lb. My Seed Catalogue sent free to all applicants.

JAMES J. H. GREGORY, Marblehead, Mass.

SILVER-LEAF DRUMHEAD CABBAGE SEED.

For MARKET or FAMILY use this is unsurpassed. It invariably forms a solid head of good size, keeps well, and always brings the best price in market. Price, per ounce, \$1.00; per pound, \$12.00. Seed Catalogues sent on receipt of stamp for postage. Address

R. H. ALLEN & CO.,
189 and 191 Water St., New York City.

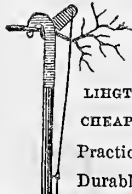

Agents wanted for
WATERS' TREE
PRUNER.



Send for Circular and Price List, to
E. S. LEE & Co.,
Box 642,
Rochester, N. Y.

Received Special Medal of Award at Am. Inst. 1872.

Price, with 4 foot pole.....	\$2.50
" " 6 " ".....	2.75
" " 8 " ".....	3.00
" " 10 " ".....	3.25

✓ Samples C. O. D. or on receipt of price.



PEACH TREES.

Stand. and Dwarf Pears,
CURRANTS, GOOSEBERRIES, BLOOD-LEAVED PEACHES, PLUM SEEDLINGS, OSAGE ORANGE, And a full line of other stock.
THE HEIKES NURSERY CO., Dayton, O.

PEACH TREES—Leading sorts.—No. 1 Trees \$8 per 100, \$60 per 1,000. Extra Apple Trees, Hedge Plants, and general variety trees and plants at low rates.
JOHN WAMPLER, Carthage, Missouri.

BRANDYWINE Raspberries, red, \$2 per 50, or \$30 per 1,000. *Herstine*, large, red, hardy, \$5 per 50. *Boyd's No. 30* Strawberries, \$1.25 per 100, post-paid. *Mourich*, \$1 per doz., \$6 per 100. *Wilson's*, \$3.50 per M, \$30 per 10,000. Specialties. Also other Small Fruits, Trees and Vines.
Berry Baskets—various kinds—in lots of 50 or 50,000. Price-lists, with references, etc., free.
R. H. HAINES, Malden-on-the-Hudson, N. Y.

SMALL FRUIT PLANTS and **PEACH TREES**—genuine—at low rates. See page III, last number *Am. Agriculturist*. Catalogues free.
JOHN S. COLLINS, Moorestown, N. J.

ANGER'S QUINCE STOCKS.—No. 1 \$14; No. 2 \$10 per 1,000. Apple Seedlings.—No. 1 \$5; No. 2 \$4 per 1,000. **T. & H. HALE**, Wales, N. Y.

TREES, Etc.

SPRING OF 1874.

We invite the attention of Planters and Dealers to our large and complete stock of

Standard and Dwarf Fruit Trees, Grape Vines, Small Fruits, Ornamental Trees, Shrubs, Roses, New & Rare Fruit & Ornamental Trees, Evergreens, and Bulbous Roots, New & Rare Green & Hot House Plants.

Small parcels forwarded by mail when desired. Prompt attention given to all inquiries. Descriptive and Illustrated Priced Catalogues sent prepaid on receipt of stamps, as follows:

No. 1—Fruits, 10c. No. 2—Ornamental Trees, 10c. No. 3—Greenhouse, 10c. No. 4—Wholesale Free.

Address
Established 1840. **ELLWANGER & BARRY,**
Mount Hope Nurseries, ROCHESTER, N. Y.

Trees! Flowers!

All Kinds—Wholesale and Retail.
Dutchess Nurseries, Poughkeepsie, N. Y.
Choice Stock. (Established 1863.) Cheap Rates.
ELMS for avenues, fine Norway Spruce, American Arbor-vita, Hemlock, etc. **Walter Grape** (only American raisin Grape) and Downing Gooseberries, Specialties.
Greenhouse and Bedding Plants very cheap, in large or small quantities. Send for Priced Catalogue.
OFFER! 12 Choice Bedding Plants in 8 sorts, sent by mail, post-paid, for \$1. Safe arrival guaranteed.
An extra Plant to all who state where they saw this adv't.
W. L. FERRIS, JR., & CO., late L. M. Ferris & Son.

Sweet	600,000 SWEET CHESTNUT.
	10,000 SPANISH CHESTNUT.
	A Circular free.
Chest-	200,000 GREEN-HOUSE PLANTS.
	A 56-page Catalogue free.
	25,000 ROSES, dormant.
	25,000 ROSES, in pots, for Spring.
	100,000 GRAPE-VINES.
	5,000 TULIP TREES, 6 to 10 feet.
	50,000 PEACH TREES, First-class.
	2,000 WEEPING MOUNTAIN ASH.
	1,000,000 EVERGREENS. Best in the market.
	100,000 DECIDUOUS TREES.
	500,000 FRUIT TREES.
	20th Year. 300 Acres.
	11 GREEN-HOUSES. Address
	STORRS, HARRISON & CO.,
	PAINESVILLE, Lake Co., Ohio.

CHOICE TREES,

FRUIT and ORNAMENTAL. SHRUBS and HARDY PLANTS. ROSES a specialty. All at low prices to suit the times. Send for our new PRICE-LIST per dozen, 100 or 1,000. Address **W. S. LITTLE,**
Commercial Nurseries, Rochester, N. Y.

TREES. Imported and Native Nursery Stock at Wholesale and Retail. Price-list mailed free.
A. P. CHAPMAN,
50 and 52 Vesey St., New York.

GRAPE-VINES.

All leading varieties. Extra quality. Genuine. Cheap. Price-list free.
T. S. HUBBARD, Fredonia, N. Y.

Norway Spruce.

A large and splendid stock, 2 to 6 feet, at very low rates. Also Pears, Apples, Peaches, and a general Nursery Stock, by **SMITH & POWELL,** Syracuse, N. Y.

NORWAY SPRUCE, 100,000. Very fine. **FRUIT TREES**—A large stock. Send for Catalogue.
J. W. ADAMS, Springfield, Mass.

200,000 Transplanted Evergreens \$1.05 will buy 1,000 transplanted *Arbutus*, packed and delivered at R.R. or Express office. Catalogues, and How, When, and where to Plant Evergreens mailed for stamp.
WM. MORTON & SON,
Allen's Corner, Cumberland Co., Maine.

Native Evergreens.
Balsam Fir, Arbor-Vita, White Pine, Spruce, and Hemlock. Also Larch. 5 to 12 inches high at \$3 per 1,000; \$10 for 5,000. Packing free. **JAS. A. ROOT,** Skaneateles, N. Y.

THE INEXHAUSTIBLE—New Ever-bearing *Strawberry*.—A cross of Victoria and Pineapple, by (Mabelle) France. Large berries from May to frost. 1 plant, 50c.; 5, \$2; 10, \$3. Clons of *Souvenir du Congrès*—size monstrous, ripens before Bartlett. New Strawberries, Raspberries, Blackberries, and Currants. Send for descriptive catalogue.
W. S. CARPENTER & SON, Rye, Westchester Co., N. Y.

ALBANY SEEDLING STRAW-BERRY—\$2.50 per 1,000. *Seth Boyden's* No. 30—\$3 per 1,000. *Chas. Downing* and *Kentucky*—\$2.50 per 1,000.
SAMUEL C. DE COU, Moorestown, N. J.

ROSES.

Eight Well-Established Pot Plants of everblooming sorts sent securely packed by mail for

ONE DOLLAR.

These will bloom the entire summer in the open ground, and at this price persons at the North can afford to let them go with the Verbenas and other Bedding Plants in the autumn. Send for our list of \$1 collections of plants. The cheapest offer in the whole country.

MASSEY & HUDSON,
Chestertown, Kent Co., Maryland.

BEAUTIFUL EVER-BLOOMING ROSES,

STRONG POT-PLANTS, Suitable for Immediate Flowering. Sent Safely by Mail, Post-paid.

5 Splendid Varieties, purchaser's choice, \$1; 12 for \$2. For 10 cents additional we send

MAGNIFICENT PREMIUM ROSE.

Our elegant SPRING CATALOGUE for 1874, describing more than 200 FINEST VARIETIES of Roses, and containing full directions for culture, with chapters on winter Protection, Injurious insects, etc., now ready. SENT FREE.

THE DINGEE & CONARD CO.,
Rose Growers,
WEST GROVE, Chester County, Pa.

ROSES! A Specialty at the Rochester Commercial Nurseries. The best are the cheapest. extra plants from large pots for immediate blooming, \$3 per doz. by Express. Small plants by mail very cheap. Splendid imported Tree Roses. All kinds of Fruit and Ornamental Trees and Plants. Send for our Circulars.
Address **W. S. Little, Rochester, N. Y.**

ROSES 6 for \$1, 14 for \$2, by mail, post-paid.
A large collection of Bedding Plants, Hardy Shrubbery, etc. Plants by mail a specialty. A **SPLENDID PREMIUM ROSE** with each **PACKAGE** when 10c. is added. Catalogue free on application. Address **JOSEPH T. PHILLIPS,** West Grove, Chester Co., Pa.

PLANTS BY MAIL PACKING AND POSTAGE FREE	LADIES' TABLETS
	<p>12 Verbenas, 12 kinds, - - - \$1.00 10 Bedding Plants, 10 kinds, - 1.00 10 Basket Plants, 10 kinds, - 1.00 6 Roses, 6 kinds, - - - - 1.00 6 Geraniums, 6 kinds, - - - 1.00</p> <p>All named sorts, our choice. 100 other things cheap. A Premium offered to Clubs. A 56 page Catalogue Free. 20th year, 300 acres, 11 Greenhouses Address STORRS, HARRISON & CO., Painesville, Lake Co., Ohio.</p>

VERBENAS.—1 Doz. Fine Varieties packed and sent anywhere for \$1.00.
BEDDING PLANTS.—1 doz. ass'd for Bloom through the Summer. \$1.50, with Basket.
ROSES.—1 Doz. assorted Tea, China, and Hybrid for \$2.50, packed and shipped. Send for Catalogue.
B. P. CRITCHELL, Cincinnati, O.

FLOWER SEEDS

I will send by mail, post-paid, 50 varieties of choice Flower Seeds for \$2.00, 25 varieties for \$1.00, 10 varieties for 50c.
R. H. HARRIS, Yarmouth Port, Mass.

C. C. C.—The true CAPE COD CRANBERRY—best sort—Upland, Lowland, or Garden—by mail prepaid. Priced Catalogue gratis of this and all Fruits, Ornamental Trees, Evergreens, Shrubs, Roses, Plants, etc., and Fresh Flower and Garden Seeds (25 sorts \$1)—the choicest collection in the country—with all novelties.
500,000 Conover's and Giant Asparagus, 1, 2, and 3 years.
B. M. WATSON,
Old Colony Nurseries and Seed Warehouse,
Plymouth, Mass.

MERRACUTE PRESSERS, OILS, FRUIT CAN TOOLS.

Matthews' Garden Seed Drill.
Devised by the inventor and manufacturer of the Holbrook "Regulator" Drill to excel that or any other ever used. *Challenge the production of its equal.* Send for descriptive circular to
J. B. SMALL,
10 S. Market St. Boston, Mass.

Brick and Tile Machines.
For circulars address **J. W. PENFIELD,**
Willoughby, Lake Co., Ohio.

LOVELL'S FAMILY WASHING MACHINE.—Price \$5. A perfect success. Warranted for five years. Agents wanted. Address **M. N. LOVELL,** Erie, Pa.

**ARE YOU GOING TO PAINT?
OVER 200,000 HOUSES**

PAINTED WITH THE

Averill Chemical Paint.

White and all the fashionable shades mixed ready for use and sold by the gallon.

EXTRACTS FROM OUR LETTERS.

HON. JAS. NEGLEY, Pittsburgh, Pa.: "Altogether I find the 'Averill' the cheapest and best."
 PETER HENDERSON, Esq.: "The 'Averill' has proved superior to lead and oil."
 C. W. SPOONER, Treas., Cordage Co., Plymouth, Mass.: "The 'Averill Chemical' has proved good."
 C. A. ALLYN, Esq., Palmyra, N. Y.: "The 'Averill Paint' is as bright to-day as when applied three years ago."

Hundreds of testimonials from owners of the finest residences in the country, with Sample Card of Colors, furnished free by dealers generally, and by the

AVERILL CHEMICAL PAINT CO.,
 32 Burling Slip, New York; or 132 East River St., Cleveland, Ohio.

**Carbonized Enamel
IS AS PURE AS GLASS.**

The Bridgeport Mfg Co.,
 OF BRIDGEPORT, CONN.

(Office, No. 88 Chambers St., New York), have the exclusive control of this valuable enamel, and are using it to cover all of their celebrated

American Submerged Force Pumps.

They also enamel pipe inside and out, which delivers the water chemically pure. The Enamel is composed of vegetable matter, baked on so hard that a blow does not break it, and it resists acids that eat gold.

Gentlemen: I have examined the sections of Carbonized Enamel Pipe submitted to me by you. It is superior to any pipe I have ever seen for resisting acids and conducting water from springs or for use in connection with pumps, etc. The Enamel adheres with astonishing tenacity, withstanding even heavy blows; and the surface of the metal where the enamel is beaten off seems to be protected against the ordinary action of water.

M. C. WELD,

Late Associate Editor *Am. Agriculturist.*

MUDGE & WOODS, No. 88 Chambers St., N. Y., are the exclusive selling agents of the Bridgeport Mfg Co. for the Licenses of States, counties, and towns rights for the American Submerged Suction and Force Pumps.

The Pulsometer or Magic Pump.



The simplest, most durable, and effective steam pump now in use. Adapted to all situations, and performs all the functions of a steam pump without its consequent wear and tear. No machinery about it. Nothing to wear out. Will pump gritty or muddy water without wear or injury to its parts. It can not get out of order.

C. HENRY HALL & CO.,
 20 Cortlandt Street, New York City.

GRAPE - VINES

OUR SPECIALTY.

Price-lists for Spring, 1874, gratis. Correspondence solicited. Address ISIDOR BUSH & SON, Bushberg, Mo.

THE CROTON GRAPE.

Fine two-year-old plants of this variety by mail or express. Send for price-list.

S. W. UNDERHILL, Croton Landing P. O., N. Y.

The Snyder Blackberry

Has never winter-killed since discovered, 23 years ago. Fine flavor. No hard, sour core. Good size. Strong, erect canes, with short, stout laterals. Few thorns. Nearly straight. Needs neither protection nor stakes. Send for circular. Price—one root, 50c.; 12, \$3.; 100, \$20.; 1,000, \$150.
 J. R. GASTON, Normal, McClan Co., Ill.

Farmers, Wheelwrights,

Send for circular of the HOPE SEAT SPRING. Agents wanted.

BENJ. F. WELLS, Sole Agent,
 47 Dey Street, New York.

SOMETHING NEW in relation to Boys' Boarding School. 8th year. No extras. All books furnished free to scholars. Catalogues free. Address HIRAM H. POST, Prin., Sing Sing, N. Y.

**Choice Flowering Plants
GIVEN AWAY!**

<p>13 Fine Verbenas for \$1.00.</p> <p>18 Fuchsias for \$1.00.</p> <p>6 Fine Geraniums for \$1.</p>	<p>25 pkts. Flower & Vegetable Seeds \$1.</p> <p>18 Basket Plants for \$1.</p> <p>18 Summer Flowering Plants for \$1.</p>
---	---

The Florist's Friend and Family Visitor.—A Monthly Journal of 16 pages, \$1.25 per year. Edited by Mrs. S. O. Johnson (Daisy Eyebright). Devoted to Flowers, Home Adornments, Pursuits and Pleasures. A specimen copy, with packet of choice Double Pink Seed for 10 cts.

Each subscriber, by sending 12c. postage, can have any one of the dollar collections in this advertisement as a premium. The plants are packed in boxes, and will go in safety to any part of the country. Address
 C. A. REESER,
 ERIE, PA.

DOUBLE TUBEROSE!
 Flowering bulbs; 1st class; 10c. each; 3 for 25c.; \$1 per doz.; by mail, prepaid.

Carnation Pink Plants.
 Best winter-blooming varieties; 20c. each; \$1.80 per doz.; \$10 per 100; post-paid.
 Descriptive Catalogue of Plants, etc., free.
 CHAS. T. STARR, Avondale, Chester Co., Pa.

THE REASON WHY WE SELL

Two Millions

OF ROSES, GREENHOUSE, and BEDDING PLANTS annually is in consequence of our rates being less than half that at which they are usually sold. See Combined List of Plants and Seeds, for Clubs, Dealers, or buyers in quantity. Sent free on application.



SEEDSMEN AND FLORISTS,
 35 CORTLANDT STREET, NEW YORK.

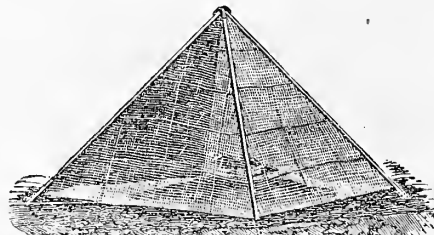

Folding Plant Protector.

THIS not only protects from bugs, borers, and fowl, but subdues all violence of wind, rain, and cold, keeping off light frosts and facilitating the growth of young plants in a wonderful degree. When open they cover nineteen inches square, and when folded, twenty-four dozen can be put into a common flour barrel.

PRICE PER DOZEN, \$1.50.

Send for circular of this or for any other article wanted on the Farm or Garden. Address

R. H. ALLEN & CO.,
 189 and 191 Water Street,
 P. O. Box 576, New York City.

Send Stamp for our Illustrated Seed Catalogue.

LOVEJOY'S METALLIC WEATHER HOUSES

Indicate the changes in the weather, and are pretty nautical ornaments. The little lady appears in fair and the man in stormy weather, and they never make mistakes. Sent prepaid to any address, safely packed, upon receipt of \$2 (Two), by ALVAN L. LOVEJOY, Proprietor and Manufacturer, 229 Washington St. Boston. Special price to dealers.

FIRST Premiums awarded by Amer. Inst., 1870.

MICROSCOPES.

Illustrated Price-List sent free on application.

MAGIC LANTERNS.

Catalogue, priced and illustrated, sent free.

T. H. McALLISTER, Optician, 49 Nassau-st., N. Y.

AGENTS wanted to introduce our justly celebrated Articles for Ladies' and Children's wear. Indispensable and absolutely necessary. Thousands sold monthly. No lady or child can well do without them. Samples sent, post-paid, on receipt of \$2.00. Send for Illustrated Catalogue. LA PERLE RUBBER CO., 90 Chambers St., N. Y.

VEGETABLE PLANTS AND ROOTS.

For Farmers and Market Gardeners.
 Early Jersey Wakefield Cabbage Plants (cold frame), \$10 per 1,000.
 Early York Flat Dutch, and Winstingstadt, same rates.
 Early Eriant Cauliflower Plants (cold-frame), \$20 per 1,000.
 Horse-radish sets, \$6 per 1,000.
 Asparagus, Van Siedken's Colossal, 2 year old, \$8 per 1,000.
 All the above are now ready for shipment.
 New Sandringham Dwarf Celery contracted for in quantities, at special rates, delivered in July.
 Purchasers to the amount of \$25 worth of Vegetable Plants will be sent our work on Market Gardening, "Gardening for Profit," gratis; the price of the book is \$1.50. To such as do not want it, the value will be sent in additional plants.



SEEDSMEN, 35 CORTLANDT ST., New York.

TO FARMERS AND MARKETMEN.

You want none but the very best of seed, grown from carefully selected seed-stock. With the money you have to invest in manure, help, and glass, you know you can not afford to use any other; you feel very anxious about it; TRY MINE. Catalogues free to all.

JAMES J. H. GREGORY, Marblehead, Mass.

R. B. Parsons & Co.

Offer in their large assortment of all the BEST VARIETIES especially fine stocks of the following: **ORNAMENTAL TREES**, of the best sorts. **EVERGREENS** of all the rarer sorts. **RHODODENDRONS**—the best hardy Shrub. **FLOWERING SHRUBS** in large variety. **ROSES**—both dormant and in pots—strong. Also, by MAIL, smaller plants for summer blooming. For Catalogues, address at **Flushing, N. Y.**

THE IVY HILL NURSERY CATALOGUE

OF SMALL FRUITS, SEEDS, and SEED POTATOES will be mailed free to all applicants. Address **REISIC & HEXAMER, Newcastle, Westchester Co., N. Y.**

SEEDS---PLANTS ---TREES---

Our Catalogues: One of Garden, Field, and Flower Seeds; Fruit, Hedge, and Tree Seeds; Grasses and Clovers; Seed Potatoes, Onion Sets, etc., and Garden Requisites. One of Fruit, Shade, and Ornamental Trees, Shrubs, Vines, Roses, Climbing Plants, Small Fruits (5-6,000 Wilson's Strawberries), etc. One of Greenhouse and Bedding Plants; Hardy Herbaceous Plants; Foliate Plants; Bulbs; Vegetable Plants (cold-frame, hot-bed, and open ground). Premiums on Vegetables for our exhibition table. Above Catalogues free to all on application.

D. H. BROWN & SONS,
 Seedsmen and Dealers in Nursery Stock and Plants,
 20 Hiram Street, New Brunswick, New Jersey.

VEGETABLE SEEDS, FLOWER SEEDS, FIELD SEEDS.

For Catalogues, write to **J. M. THORBURN & CO.,** 15 John St., New York.

FREE. The Descriptive Price-List of Trees, Shrubs, Grape-Vines, Small Fruits, Roses, and Bedding Plants, which we forward by mail or express. A large assortment of nursery stock suited to Lawns, Park, and Cemetery planting. Send for Price-List. **WILLIAM H. MOON, Morrisville, Pa.**

Hawthorne Hedge Plants.

2 years, first class extra, at \$8 per 1,000.
 2 years, second class extra, at \$5 per 1,000.
JAMES A. ROOT, Skanateles, N. Y.

F. X. HEISSINGER, Practical Landscape and Garden Engineer, 196 BROADWAY, ROOM 19, NEW YORK.

Furnishes Plans and Specifications for Parks, Private Grounds, Greenhouses, Conservatories, Rustic Works, etc., etc.; also superintends the execution of such works. Plans of works already executed can be seen at the office. Premiums received at exhibitions at Munich 1858 and 1861; the World's Fair, Vienna, 1873; American Institute, N. Y., 1873.

The Kansas Farmer. In its 12th year. Enlarged, improved, and published weekly. All about Kansas. A large corps of able writers. Sample copy free to all applicants. **T. K. HUDSON, Ed. and Propr.,** Topeka, Kansas.

\$290 Piano. Circulars free. **U. S. Piano Co. 810 Broadway, N. Y.**

Universal Fertilizer.

Guaranteed to contain not less than

5 per cent of Ammonia,
4 per cent of Actual Potash,
8 per cent of Soluble Phosphoric Acid,

Besides reverted phosphate, bone phosphate, and other essential and valuable constituents.

It is in the form of a dry and fine powder, uniform and invariable. Send stamp for our descriptive circular.

We have had this fertilizer prepared expressly to offer to farmers and gardeners a substitute for Peruvian Guano, which shall exceed it in practical value for all crops.

Price \$60 per ton, in bbls. of 250 lbs. each. Sample bags. Also **PERUVIAN GUANO** direct from Government Stores. Price reduced to \$70 per ton, under guarantee.

Various other Fertilizers, Seeds, and Agricultural and Horticultural Implements, Tools, and Machines, etc.

R. H. ALLEN & CO.,

P. O. Box 376. 189, 191 Water St., NEW YORK.

CHARLES TREMAIN,

Manufacturer of the best and cheapest fertilizer in use.

Manlius Plaster.

ANALYSIS:—"Manlius" pure Gypsum, 94.23; Nova Scotia do., 85.36; Cayuga, 71.75; Virginia do., 62.42.

MANLIUS CEMENT,

In use on GOVERNMENT, CITY, and STATE WORKS, RAILROADS, RESERVOIRS, and CISTERNS for strong and ordinary Masonry.

Has received the encomiums of eminent engineers, who place it foremost in the ranks of Hydraulic Cements.

QUICK LIME—A pure caustic Lime for Farmers' and Builders' use. Special freights obtained. Send for circular.

Works at **MANLIUS, N. Y.**



Farm Implements AND FERTILIZERS.

Buy the Best and at Lowest Prices.



Agricultural Almanac Sent Free.

H. B. GRIFFING,

53 & 60 COURTLANDT STREET, N. Y.

GENUINE

Peruvian Guano.

FARMERS, AGRICULTURISTS, and DEALERS in Fertilizers have now an opportunity of obtaining this valuable manure in small or large lots, at importers' prices, by applying to the Special Agency just established for the purpose of delivering Genuine Peruvian Guano to consumers at any accessible port or railway station in the country. Full particulars given in circular mailed free on application to

R. BALCAZAR,

No. 53 Beaver Street, New York.

REFERENCES BY PERMISSION:

Messrs. HOBSON, HURTADO & Co., Financial Agents of the Peruvian Government, 52 Wall Street, New York.

Messrs. TAYLOR, Pres. National City Bank, 52 Wall St., N. Y. J. C. TRACY, Esq., Peruvian Consul, 26 1/2 Broadway, N. Y.

50c., \$1, and \$1.50 PER GALLON.

Cottage Color Paints.

Ground in Oil and mixed ready for use. In cans, kegs, and bbls. Liquid Slate Roof Paint, Cheap, durable, and fire-proof. Send for cards of Colors and Testimonials.

NEW YORK CITY OIL CO., SOLE AGENTS, 116 Maiden Lane, New York.

SELF-ACTING GATES. NICHOLSON'S PATENT. The best in the world. Address AMERICAN GATE CO., Cleveland, O.

Don't You Forget It.

MEANS WHAT HE SAYS.

See advertisement in March number of the *Am. Agriculturist*, page 113, headed

A Household Necessity. TRIUMPH SWEET CORN,

a new and valuable variety. For sale only by the originator. Free by mail at 25 cts. a package; 5 pkts. \$1.00; selected ears \$1.00 each. Address

DAVID C. VOORHEES, Blawenburgh, N. J.

CTSR. Tested Novelties & very Desirable Vegetable and Flower Seeds.

Westchester Co. (N. Y.) Cucumber Pickle Seed produces at the rate of 400,000 to the acre. Arlington, Canada Victor, Trophy, and Hathaway's Excelsior Tomatoes. Gipsy Water-melon (best ever introduced), Nectar and Hackensack Musk-melons, Mammoth Chili Squash (often weighs 200 lbs.), Marblehead Squash. Fottler's Early Drumhead Cabbage, Egyptian Beet. Each 10 cts. pkt., 6 pkts. 50 cts., 13 pkts. \$1.00.

Double Camellia Balsam, Double Portulaca Mixed Colors, Diadem Pink. Each 10 cts. pkt.

My Catalogue for 1874 (48 pages) and a pkt. of any of the above seed sent to any address for 10 cts., or without seed for a 3-cent stamp.

5 pkts. Choice and Showy Flower-seeds 25 cts.; 12 pkts. 50 cts.; 25 pkts. \$1.00.

25 pkts. Vegetable Seeds by mail, prepaid, \$1.00.

12 Tomato Plants, either of above varieties, by mail, for 50 cts., or 25 for \$1.00.

It is no longer an experiment to plant my seeds, as any one can learn by "what my customers say" in my Catalogue. **H. E. ACKER,** Seed Grower, Woodbridge, N. J.

CTSR. CTSR. CTSR. CTSR. CTSR. CTSR. CTSR. CTSR. CTSR. CTSR.

CTSR. CTSR. CTSR. CTSR. CTSR. CTSR. CTSR. CTSR. CTSR. CTSR.

CTSR. CTSR. CTSR. CTSR. CTSR. CTSR. CTSR. CTSR. CTSR. CTSR.

CTSR. CTSR. CTSR. CTSR. CTSR. CTSR. CTSR. CTSR. CTSR. CTSR.

CTSR. CTSR. CTSR. CTSR. CTSR. CTSR. CTSR. CTSR. CTSR. CTSR.

CTSR. CTSR. CTSR. CTSR. CTSR. CTSR. CTSR. CTSR. CTSR. CTSR.

CTSR. CTSR. CTSR. CTSR. CTSR. CTSR. CTSR. CTSR. CTSR. CTSR.

GAMEWELL'S GARDENS,

GAMEWELL BRO'S, Proprietors, (Near Midland R.R. Depot), Hackensack, N. J.

Flowering and Bedding Plants at lowest market prices. Send for Circular.

The reason why we don't annually sell

Two Millions

OF

Roses, Greenhouse, and Bedding Plants

Is that the Millions have not yet learned that our prices are less than those of any other Florists. Send for our Price-list and give us a trial, and we will soon sell the two millions and more.

MASSEY & HUDSON, Chestertown, Kent Co., Md.

NEW HARDY GRAPE. THE CAMBRIDGE.

Hovey & Co. are now sending out this new and valuable grape, somewhat resembling the Concord, but harder than the Concord—earlier than the Concord—and superior to the Concord. Never mildews, never needs any protection. Young vines \$3 each, \$30 per dozen. Send for our descriptive Plant Catalogue. Address, **HOVEY & CO., 53 North Market St., Boston.**

Self-Propel-For Cripples For In and State your weight for illustrated styles and prices. Please mention this paper. Will remove May



ling Chairs and Invalids Out Door Use. and send stamp circular of different S. A. SMITH, 90 William St., N. Y. City. 1st to 32 Platt St.



Improved Foot Lathes.

Small Engine Lathes, Small Gear Cutters, Hand Planers for Metal, Ball Turning Machines, Slide Rests, Foot Scroll Saws. The very best. Selling everywhere. Catalogues free. N. H. BALDWIN, Laconia, N. H. Just the articles for Artisans or Amateurs.

Something New.

Agents wanted for the **HOPE SEAT SPRING.** Send for circular. **BENJ. F. WELLS, Sole Agent,** 47 Dey Street, New York.

Turtle Harrow.

Wrought-iron frame! Back-slant steel coulter teeth! Self-sharpening! Self-clearing! Every one warranted! The most perfect agricultural tool ever offered. Also the best steel plows. The best subsoil plow. Premium side-hill and level land plows. Victor horse hoes, and a general variety of the latest and best implements.

CARR & HOBSON, 56 Beckman Street, New York.

THE DONNELLY PLOW ATTACHMENT.

This is figured and described in this number, page 132. It saves two thirds of the labor in planting potatoes, half the labor in putting in spring grains, and enables any plow and almost any plowman to do excellent work. In fact, it

PERFECTS THE PLOW.

Price \$5. Liberal discounts to the trade. Address **WM. DONNELLY,** 397 Herkimer St., Brooklyn, N. Y. R. H. ALLEN & CO., 189, 191 Water St., New York, are General Agents. N. CORWIN & SON, River Head, are agents for Suffolk Co., L. I.

SESSIONS & KNOX'S Patent Hard Steel Plows.

Awarded Highest Prizes by the New York State, N. H. State, Vermont State, and New England Agr'l Societies.

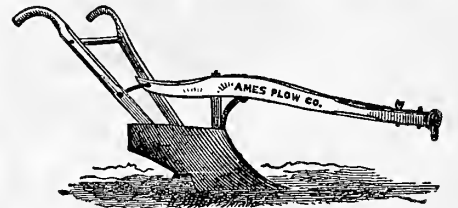

Steel Plows possess many advantages over Cast-Iron Plows. The Patent Hard Steel Plows have all the desirable qualities of hardness, flexibility, lightness, strength, and durability combined, and embrace all sizes and styles adapted to every kind of soil and to all localities. Perform better work, and pass through the soil more easily than other plows.

Also Swivel Plows for Side-Hill and Level Land, Eagle, Knox's Pat. Imp'd, and other Plows.

Made only by **AMES PLOW COMPANY,** 53 Beckman St., New York, and Quincy Hall, Boston. Descriptive circulars and price-lists sent free on application.

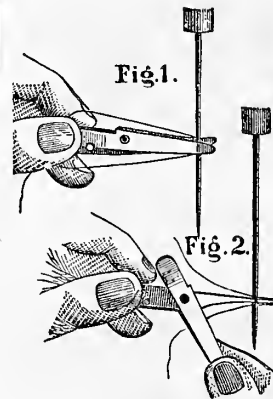

Seven reasons why *Every Lady* using a Sewing Machine should have the

MAGIC THREADER:

1st. it saves the eyes; 2d. it saves the nerves; 3d. it saves pointing the thread; 4th. it saves looking for the eye; 5th. it saves time; 6th. it is a great help in setting the needle; 7th. it is simple, reliable, and well made. Sent by mail, post-paid, with instructions, for 25c.; or one threader and 1/2 doz. standard needles for 50c. In ordering, give name of machine. Agents wanted everywhere. **THE ARGO MFG CO.,** Springfield, Mass. Box 342.

Sexual Physiology.

By R. T. TRALL, M. D. Containing Sexual Generation; the Physiology of Menstruation; Impregnation; Pregnancy; Parturition; Lactation; the Law of Sex; Regulating the Number of Offspring; The Law of Sexual Intercourse; Hereditary Transmission; Philosophy of Marriage. Prof. Wilder, of Cornell University, says it is the best work yet written on the subject. 20,000 sold. Price \$2.00 by mail. For \$3.50 we send this book, *The Herald of Health* for one year, and a volume of the Complete Works of Shakespeare, containing 1,000 pages and 36 illustrations. Agents wanted. **WOOD & HOBBS,** 15 Light St., New York.

BUILDING FELT.

This water-proof material, resembling fine leather, is for outside work (no tar substances used) and inside, instead of plaster. Felt carpetings, etc. Send two 3-cent stamps for circular and samples. **C. J. FAY,** Camden, N. J.

WANTED.—The United States Life Insurance Company is now reorganizing its Agency Department, and is prepared to negotiate with gentlemen of business ability to act as Agents. Previous connection with the business is not considered necessary. Apply at the Home Office, 261 Broadway, New York. **JOHN E. DEWITT, President**

"Our Preference is the Buckeye."

-American Agriculturist, June, 1872.

TWO FIRST PREMIUM GRAND MEDALS FOR MERIT At Vienna, 1873.

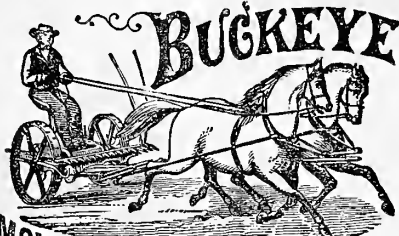

MOWER & SELF-RAKING REAPER
165 GREENWICH ST. N.Y. OFFICE
FACTORY POKEEPSIC N.Y.

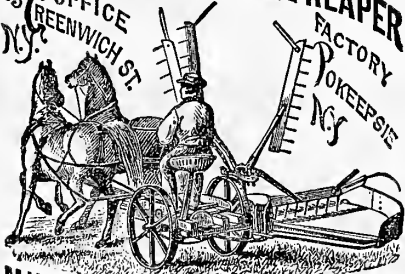

MANUFACTURED BY ADRIANCE, PLATT & CO

STYLES, SIZES & PRICES TO SUIT ALL FARMERS. Descriptive Circulars Forwarded by Mail.

The Superior Hay Spreader

(Improved and perfected for season of 1874).

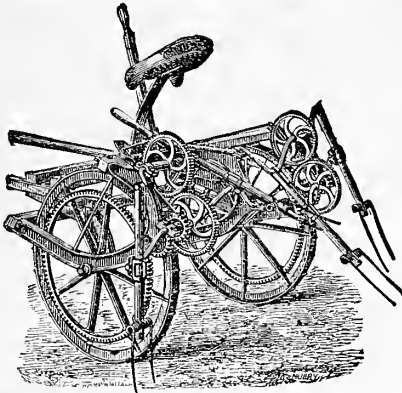

This machine will do the work of ten men. It is the lightest draft machine ever built, one horse working it easily. It has taken first premiums wherever exhibited. Send for a descriptive circular. The Superior Spreader is unsurpassed in beauty, workmanship, and durability. Manufactured by

THE HIGGANUM MANUFACTURING CO., Higganum, Conn.

Address for Price List and description, **P. K. DEDERICK & CO., ALBANY, N.Y.** BALE HAY without Tramping or Stopping.

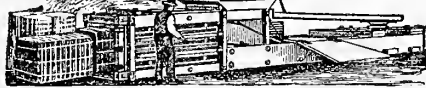

THE P. K. DEDERICK PERPETUAL HAY PRESS

Bales hay faster, puts it in better shape, with less help and less expense than any other. A whole stack or mow of hay may be pitched into it without stopping or tramping, and will be discharged in bales by the machine without assistance. See them in operation at our works, Tivoli St., Albany, N. Y.; No. 90 College St., Montreal, P. O.; No. 165 West 16th St., Chicago, Ill.; Cor. Wilkinson Ave. and Third St., N. St. Louis, Mo.



CHAPMAN'S. The best Fork and Conveyor in use. Recommended by a host of those who have tried it. Saves labor, time, money. Sent on trial. Agents wanted. Circulars sent. **G. B. WEEKS & CO., SYRACUSE, N. Y.**

SEEDS!

Tested, Fresh, and Reliable. Flower, Field, and Garden Seeds, wholesale and retail. (Send for Catalogue.) Seeds in boxes on commission. **DETROIT SEED COMPANY, 20 and 22 Michigan Ave., Detroit.**

TWO GOLD MEDALS

For a Show and easy movement of horses, is roads less than 1 1/2 miles per hour, mechanical construction of machine and material in every place, nothing so light, excellent work, etc., as shown by official report of judges. Thrashers, Separators, Fanning Mills, Wood Saw, Seed Sowers and Planters, all of the best in market. Catalogue with price, full information, and Agents' Report of MINARD HARRIS, Cobleskill, Schoharie Co., N. Y.

At Great National Trial, at Auburn, N. Y. THE FIRST PRIZE

Harriet's Premium Millinery Horse Power and Thresher and Cleaner, received, AWARDED THIS MACHINE

THE BEST IN AMERICA

Sugar Cane and Sorgo Machinery,

Steam Engines, Horse Powers, Farm Mills etc.

Manufactured by **GEO. L. SQUIER & BRO., Buffalo, N. Y.** Catalogues free.

Diamond State Separator.

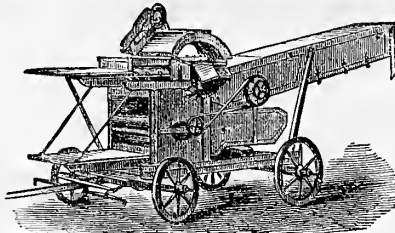

No. 1, 28 inch cylinder, 39 inch separator, \$225.
No. 2, 30 " " 41 " " 265.
No. 3, 30 " " (For Steam Power) 300.
Simplest, lightest-running, cheapest, and best separator in market. Address **TAYLOR M'FG CO., Westminister, Md.** Agents Wanted.

SPRING STEEL TOOTH. ITHACA HORSE RAKE.

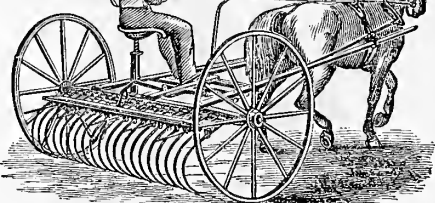

EXCELS ALL OTHERS.

Thousands in use giving entire satisfaction. Manufactured by **WHEELER & MELICK CO., Albany, N. Y.** **WILLIAMS BROS., Ithaca, N. Y.** **YOUNGLOVE, MASSEY & CO., Cleveland, O.** **GRAND RAPIDS M'FG CO., Grand Rapids, Mich.**



FOUST'S PATENT HAY LOADER. manufactured at the MEADVILLE AG'L WORKS, Meadville, Pa. Warranted to elevate a ton of hay from the winnow to the wagon in five minutes, and take it as clean as by the hand fork, and to be adapted to all ordinary meadow land. Send for Descriptive Circulars.



Straw Preserving Thresher. This Machine leaves the straw straight and unbroken, when it can again be put into bundles, making it more valuable for market. **WHEELER & MELICK CO., Sole Manufacturers, Albany, N. Y.** Send for circular.

TO FARMERS & PLANTERS.



DOUBLE REFINED POUDETTTE for sale in lots to suit customers. This article is sold for half the price of other fertilizers, and is cheaper for Cotton, Corn, Tobacco, and Vegetables than any other in the market. Price, delivered on board in New York City, \$25 per ton. Ask attention to the following testimonials:

CHARLES A. MESSENGER, Providence Co., R. I., writes: "The Double-refined Poudre I bought of you has given satisfactory returns, and I consider it the best of anything I can use for an early crop."

THOMAS W. LATHAM, Providence Co., R. I., writes: "I would rather have your Double-refined Poudre than any phosphate I ever used. Where I used it on Potatoes it was far ahead of any other manure."

L. H. SHELDON, Sup't of the New Jersey State Reform School, writes: "We have used Poudre for several years upon our farm crops, and for the money invested we have found nothing that has done us so much service."

S. J. KELLY, Burlington Co., N. J., writes: "I used Double-refined Poudre on Rutabaga Turnips alongside of Peruvian Guano and Hen Manure. Where the Poudre was applied the increase was thirty per cent over the others."

WILLIAM H. CADY, Ocean Co., N. J., writes: "I used Poudre on Corn, Sweet and round Potatoes, Onions, and Lima Beans. It brought forward my crops two weeks earlier. I think it the best manure I ever used, giving better results than Peruvian Guano, at much less cost."

VAN ANTWERP AND VAN BUREN, Montgomery Co., N. Y., writes: "Poudre has been used in this locality for ten years past, mostly on Corn, and those who have used it say they have from 1/4 to 1/2 more Corn by using the Poudre."

W. F. GERKIN, of Essex Co., N. Y., writes: "I have used the Double-refined Poudre for the last five years, and I consider it the cheapest fertilizer I can buy—giving the best results for the cost."

MILTON STRONG, Suffolk Co., N. Y., writes: "I gave Poudre a thorough trial this year, using it upon Corn, Potatoes, Lima Beans, Tomatoes, and Vines, and I have never raised better crops. My Corn will yield 100 bushels of ears per acre, and my garden was the surprise and admiration of all who saw it."

HENRY T. HORTON, Cheshire Co., N. H., writes: "I find, from experiments made last year, the Double-refined Poudre is the cheapest fertilizer to use on Tobacco. I put it beside Peruvian Guano with equal cost of both, and the Tobacco was 30 per cent better where I used Poudre."

W. H. REMINGTON, Hartford Co., Ct., writes: "I have used Poudre on Corn, Potatoes, and Tobacco. There was but one piece of Corn in the place equal to mine, and that had 30 loads of manure per acre and mine none. The Tobacco started as soon as set and grew luxuriant."

WM. S. POMEROY, of Hartford Co., Ct., writes: "I have used the Double-refined Poudre for several years on Tobacco, and I think it one of the best fertilizers made for this crop."

A Pamphlet giving full directions, etc., sent free on application to **JAMES T. FOSTER, 66 Cortlandt Street, New York.**

NOTICE TO Manufacturers of Agricultural Implements.

Parties desirous of sending their MANUFACTURES for EXHIBITION and SALE to the great INTERNATIONAL AGRICULTURAL EXHIBITION to be held at BREMEN, GERMANY, commencing June 18th, a. c., will find it profitable to use our medium, as we have made the most favorable arrangements to this effect.

HARJES & HERKLOTZ, Forwarding & Commission Agents, BREMEN. Particulars and references can be had by addressing Messrs. **RODIGER, KIERNAN & CO., 48 Broadway, N. Y.**



For full particulars, address **ENGLE, KELLER & CO., Lancaster, Pa.**

CABLE FENCING.

Cheap, handsome, and durable. Proof against Cattle, fire, and Rust. Hundreds of miles erected. Send for Circulars.

PHILIP S. JUSTICE, 14 North Fifth St., Philadelphia. 42 Cliff St., New York.

The Home Corn-Sheller.

The best HAND SHELLER for family use in the market. **EVERY MACHINE WARRANTED. PRICE \$2.50.** Every Farmer and Poultry Raiser should have it. Shipped C.O.D. to any part of the country. Dealers, address for descriptive circular **LIVINGSTON & CO., Pittsburgh, Pa.**

The Kansas Farmer.

The best agricultural paper in the West. Enlarged, improved, and published weekly. Sample copy free. **T. K. HUDSON, Ed. and Prop'r, Topeka, Kansas.**

CLAVELACK College and Hudson River Inst., at Claverack, N. Y. 20 instructors. ALONZO FLACK, Ph. D., Pres.

New Excelsior, for 1874.

PRICES OF HAND MOWERS.
No. 1.—Width of cut, 9 in., \$15
" 2.—" " " 12 in., 20
" 3.—" " " 15 in., 25
" 4.—" " " 18 in., 30

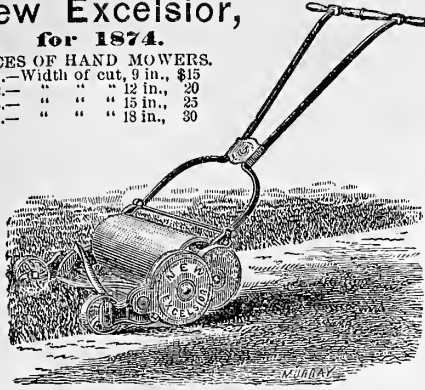

The New EXCELSIOR is simple and durable. The gearing securely increased and will not clog. Has a full roller, without which no machine is perfect. A pawl ratchet (noiseless), needs no oiling. The front rollers are adjustable, to vary the height of cut. Open balance wiper—with steel knives—the only practical means of securing strength and ease of draft. Patent adjustable wrought iron handle, attached to each side of the machine, being much superior to the single wooden handle used in other machines.

Manufactured by
CHADBORN & COLDWELL M'fg Co.,
Send for circular. NEWBURGH, N. Y.

Fanciers' Journal

AND
POULTRY EXCHANGE.

The only weekly, and the best Poultry, Pigeon, and Small Pet paper published in this country. Every family should take it. \$3.50 per annum; \$1.25 for six months; 10 cents for a specimen copy.
JOS. M. WADE,
39 N. Ninth St., Philadelphia, Pa.

EAST-LAWN DARK BRAHMAS

Are a very SUPERIOR STRAIN of this VALUABLE BREED.
A very limited number of orders for EGGS will be booked this season at \$5.00 per dozen. Address
J. M. W. KITCHEN,
Box 199. Morristown, N. J.

EGGS from Fine Stock.—Reduced prices.—Light Brahma, White Leghorn, S. G. Dorking, S. S. Hamburg, Sebright Bantam, B. B. R. G. Bantam, Avlesbury Duck—\$2 doz., 2 doz. \$3. Partridge Cochin, Dark Brahma, Buff Cochin, Houdan—\$2.50 doz., 2 doz. \$4. Bronze Turkeys—\$1 doz. Send for descriptive catalogue.
W. S. CARPENTER & SON, Rye, Westchester Co., N. Y.

**BROWN LEGHORN FOWLS,
PARTRIDGE COCHIN.**
Send for Illustrated Circular.
R. H. HARRIS, Yarmouth Port, Mass.

LEGIORNS, Lt. and Dk. Brahm.
Stock the finest in the world. Eggs in season. Pure Italian queens, \$1.00 each. Address
J. A. BUCHANAN, Wintersville, Jeff. Co., Ohio.

BRONZE TURKEYS—descended from stock weighing 62 lbs. the pair. **PEKIN DUCKS.**
JERSEY CATTLE AND BLACK BASS.
Address **W. CLIFT,** Mystic Bridge, Ct.

Improved Blooded Live-Stock.

N. GUILBERT Evergreen Farm, Gwynedd, Pa. Importer and breeder of Horses, Cattle, Milch Cows, Cotswold and South-Down Sheep; best Swine; all kinds Geese, Ducks, Turkeys; Cochin and all other kinds of Poultry; Peacocks; Eggs; Dogs; Maltese Cats; Rabbits; Guinea Pigs; White Mice; Eagle, Monkey, Raccoons, Deer, Swan, etc. Prices low. Wanted—Deer, Swan, and Wild Geese.

AYRSHIRE BULLS.—From first-class Herd Book. Milking stock. Six months to 2 yrs. old. For pedigree, price, etc., address **E. O. CUITISS,** Ravinstream Stock Farm, Stratford, Ct.

Herd Register Jerseys
Fifty head at auction, April 8th, 1874. Send for Catalogue. **J. HOWARD McHENRY,** Pikesville, Balt. Co., Md.

A HERD BOOK AYRSHIRE BULL for sale; is 4 years old, free from faults, and from the best strains of milking stock. Price \$30. Address
J. ANDREW CASTERLINE, Dover, N. J.

JERSEY CATTLE. For sale by **G. W. FARLEE,** Crosskill, N. J.; 1 hour from N. Y.
ESSEX PIGS.

**BEE KEEPERS.
MANOR BEE HIVE & TRAP.**
Divide a colony in three minutes without disturbing them. Set half a colony on the warior table, and let no bees escape. Town-ship rights from \$10 up. Send stamp for circular.
DR. S. T. DAVIS,
Millersville, Lancaster Co., Pa.

BEES and SUPPLIES will be furnished by **M. QUINBY,** St. Johnsville, Montgomery Co., N. Y. Price-list sent to all applicants.

EMPIRE. The Simplest, Strongest, and Easiest Running
Lawn Mowers
MADE.

Price,
14 in. cut,
\$20.00.

All who need a Lawn Mower, either for a small or large lawn, should examine the merits of Walker's Patents, Empire and Monitor. They are simple in construction and very light, not fatiguing the operator. Send for Circular. Agents wanted in every town. Manufactured by
BARLOW & WALKER
Sing Sing, N. Y.

MONITOR.
Price:
No. 0, 10 in. cut,
\$15.00.
No. 1, 14 in. cut,
\$20.00.

"VULCANIZED RUBBER-COATED IRON PIPE"
FOR WATER, GAS, &c.
Manufactured under Patents **MORRIS, TASKER & CO.,**
Solely by
For sale by them, their Agents, and Dealers generally. **PHILADELPHIA.**

Samples from
B. E. Hale & CO.,
56 and 58 Park
Place, N. Y.
Sole Agents for
Eastern States.

BUILDING PAPER!
FOR SHEATHING, ROOFING, DEAFENING, CARPET LINING, AND PLASTERING!

Samples from
Rock River Paper
Company,
Chicago, Ill.

Every Man His Own Painter.
NEW JERSEY ENAMEL PAINT COMPANY,
MANUFACTURERS OF
LIQUID ENAMEL PAINT,
BRADLEY'S PATENT.
In pure white, and any shade, tint, or color desired. Put up in 1, 2, 3, 4, 5, 10, 15, 20, and 40 Gallon Packages. Mixed ready for use. Are easily applied by any one. Require no mixing or addition of dryers. For sample color-card and price-list address
NEW JERSEY ENAMEL PAINT CO.,
Raritan, New Jersey.

ESTABLISHED 1837.

ECKSTEIN, HILLS & CO. PURE WHITE LEAD.

We offer the above brand of White Lead to the public with the positive assurance that it is
PERFECTLY PURE.
For sale by dealers generally.
ECKSTEIN, HILLS & CO.,
CINCINNATI, OHIO.

NOTE.—Consumers will consult their INTEREST by bearing in mind that a large proportion of the article sold as PURE WHITE LEAD is adulterated to the extent of from 50 to 90 per cent; and much of it does not contain a particle of Lead.

ESTABLISHED 1858.

PRINGLE'S METALLIC PAINT.
72 lbs. Metal in the 100 lbs. Warranted Fire Proof.
300 lbs. N. Y.
1000 lbs. N. Y.

TRADE MARK PATENTED.

The best and cheapest Paint in the world for Iron, Tin, or Wood. For sale everywhere. **PRINGLE'S METALLIC PAINT CO.** Manufacturers, 96 Cedar St., N. Y. **CAUTION.**—Purchasers and consumers are cautioned against purchasing imitations of our METALLIC PAINT. All genuine PRINGLE'S METALLIC PAINT will bear our name and trade mark on each and every package. Send for a circular.

THE FIRST DIVISION
OF THE
St. Paul & Pacific
RAILROAD COMPANY
OFFER THEIR
LANDS
FOR SALE

At moderate prices and on 10 years' credit, if desired, and also TOWN LOTS in Towns at R.R. Stations. They will also sell PRAIRIE LANDS at low prices on 3 1/2 years' time without interest, provided the purchaser will make satisfactory improvements.
GOVERNMENT LANDS
Are still to be had under the HOME-STEAD and TREE CULTURE laws near the lines of this Company; 240 acres can thus be secured FREE, except the regular Land Office entry fees.
The State of MINNESOTA pays a bounty of two dollars (\$2) each year for 10 years, for every acre of trees planted and cultivated, and two dollars (\$2) per year for 10 years for every half mile of trees planted and cultivated along any Highway.
For particulars, address
HERMANN TROTT,
Land Commissioner, St. Paul, Minn.
EDWARD D. ATWATER, Secretary.

Adams' Celebrated Universal GLASS CUTTERS

Warranted the best in market. They cut glass better than a Diamond. Are very simple and durable. Any one can use them, and everybody needs one. We make three styles: Putty Knife, Ruler, and Ornamental. Either one sent to your address on receipt of 50 cents. A liberal discount to Agents. None genuine but those manufactured by
B. F. ADAMS & CO., Springfield, Mass.

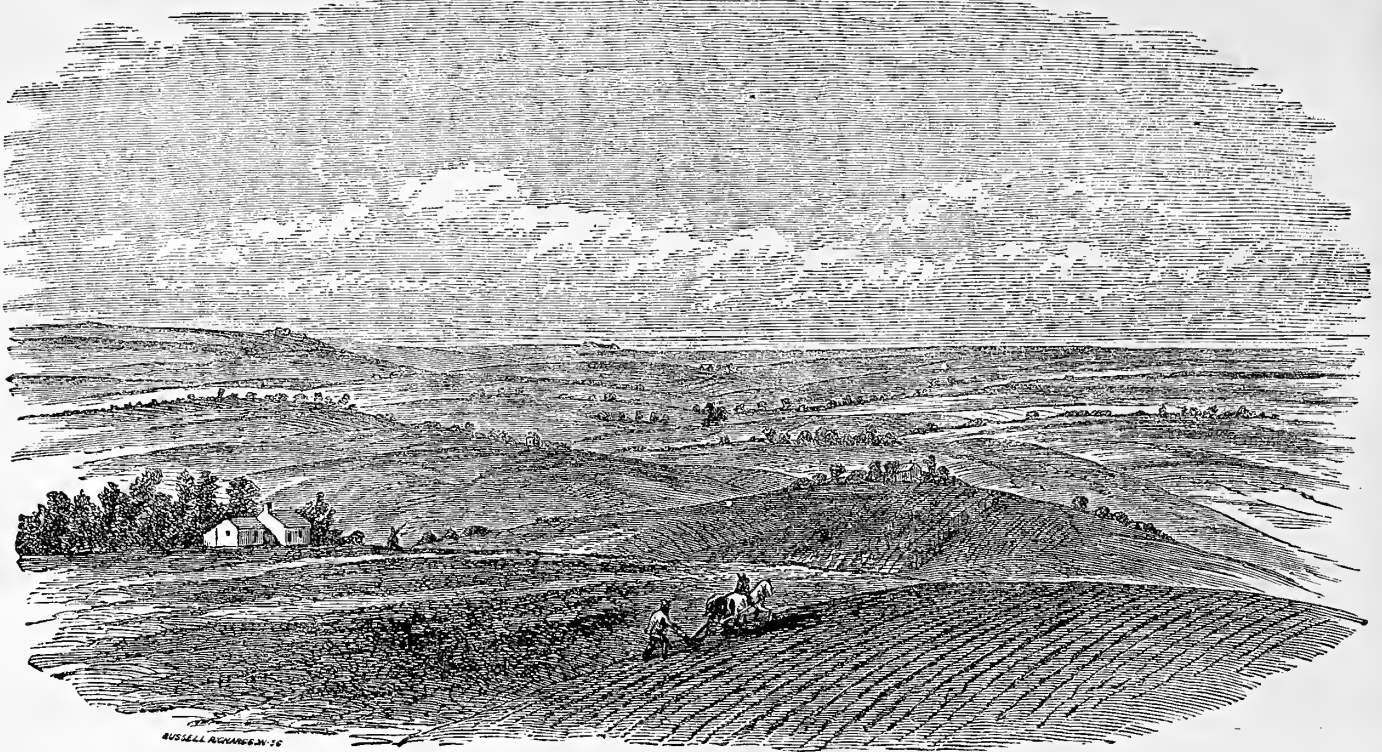

PRAIRIE, TEN MILES EAST FROM LINCOLN, NEB.

A FINE REPRESENTATIVE VIEW OF FARMS AND CULTIVATED GROVES ON ROLLING PRAIRIE.
IF YOU WANT A FARM OR HOME,
YOU SHOULD BUY OF THE

BURLINGTON AND MISSOURI RIVER RAILROAD CO.
 IN IOWA OR NEBRASKA.

- BECAUSE**—Their prices are low, ranging for the best land from Three to Ten Dollars per acre.
- BECAUSE**—No payments are required of the purchaser for four years, except interest at six per cent.
- BECAUSE**—After the fourth year only one seventh of the principal is payable annually till the whole is paid.
- BECAUSE**—You are not required to go into a wilderness, these being well-settled States, the population of which is rapidly increasing.
- BECAUSE**—The mildness of the climate and fertility of the soil is such that the settler can pay for his farm from the products raised upon it long before the time when the principal becomes due.
- BECAUSE**—Failure of crops from drouth is unknown.
- BECAUSE**—Large allowances are made upon fare and freight, thus giving low rates on both to purchasers of this Company's lands.

AND YOU SHOULD BUY THIS YEAR.

- BECAUSE**—Purchasers during 1874 who cultivate one-half their land within two years from their purchase are allowed a reduction of twenty per cent on its price.
- LARGE DISCOUNTS** also, FOR CASH, within One, Two, or Five Years.

Send for Circulars, with full information on all points, to

GEO. S. HARRIS, Land Commissioner,
 At Lincoln, Nebraska, for land in Nebraska. At Burlington, Iowa, for land in Iowa.
JAS. R. WOOD, General Agent, 59 Clark St., Chicago, Ill.

Or to **W. D. COWLES**, General Agent, 317 Broadway, New York.

HARNESSES

MANUFACTURED EXPRESSLY



FOR THE

TRACK, ROAD, PARK OR FARM.

Single at \$9, \$12, \$15, \$20, \$25, to \$200 per Set. Double at \$25, \$30, \$35, \$40 to \$500 per Set. Blankets, Sweats, Hoods, Muzzles, Clipping Machines, and Horse furnishing goods of every description, style, and grade, adapted for use on the Track, Road, Farm or Stable.

C. M. MOSEMAN & BRO.,
 Manufacturers, 114 Chambers St.,
 New York.

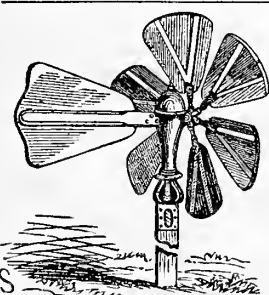

Automatic PUMPS.

Water driven to any height and distance by compressed air. Country houses supplied cheaply and certainly for bath-rooms, water closets, hot and cold water faucets, etc. Plenty of fresh water for stock on farms.

Address
HARTFORD PUMP CO.,
 41 Trumbull St.,
 Hartford, Conn.

The Banner Windmill
 Has proved itself the most reliable and perfect Windmill in use. Trial and warranty always given. Circulars free. Rare chance for agents.
N. P. MIX, Columbus, Ohio.



Goodenough Horse-Shoe.

Cheapest and Best. All fitted for Use. No Fires required.

Send for Circulars.
 Box 3,044, P. O.,
 New York.

SOMETHING NEW. LOTS OF FUN.

THE GREAT PUZZLES.

They are sure to please everybody. Packages containing one dozen different puzzles sent anywhere for 25 cents. Address **PUZZLE COMPANY**, 755 Broadway, New York. Agents, you can sell them fast. Liberal discount.

ADVERTISERS should send to **Geo. P. Rowell & Co.**, 41 Park Row, N. Y., for their *Eighty-page Pamphlet*, containing lists of 3,000 newspapers and estimates, showing the cost of advertising. Mailed free to all applicants.

NIAGARA FIRE INSURANCE COMPANY,
 201 Broadway, N.Y.

Capital Stock.....	\$500,000
Cash value of Assets.....	\$1,308,224
Total Liabilities.....	82,902
Net Assets.....	\$1,225,922

Dwellings and Farm Risks a specialty at all our Agencies.
HENRY A. HOWE, President.
P. NOTMAN, V. P. and Sec'y.

THE PENN MUTUAL LIFE INSURANCE COMPANY OF PHILADELPHIA.

ASSETS ACCUMULATED, \$1,427,996.96.
 The Penn is a purely mutual Company. All of its surplus premiums are returned to the members every year. Dividends may be applied to reduce the premium or increase insurance as desired. **SAM'L C. HUEY**, Pres.
 General and Local Agents wanted in the Middle and Western States. Apply to **H. S. STEPHENS**, Vice Pres., No. 921 Chestnut Street, Philadelphia, Pa.

Lovejoy's New SLYIC

GLASS CUTTER AND PUTTY KNIFE

Cuts glass better than a diamond. Everybody should have one. Any child can use it. Sent to your address on receipt of 60 cents and stamp by

ALVAN L. LOVEJOY
 229 Washington St.,
 Boston, - - - Mass.

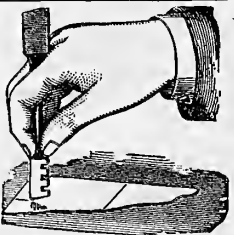

Liberal discount made to dealers.

AGENTS WANTED

for the **HOPE SEAT SPRING**, the best, cheapest, and most durable spring ever offered. Send for circular.
BENJ. F. WELLS, Sole Agent,
 47 Dey Street, New York.

New Scheme of Easy Payments

FOR

MASON & HAMLIN

CABINET  ORGANS.

The MASON & HAMLIN ORGAN COMPANY have arranged a new system, under which they now offer their well-known Organs

For Rent, with Privilege of Purchase, at prices and on terms extraordinarily favorable.

Payments may run through one to four years.

All Rent which has been paid allowed and deducted on Organs purchased and paid for within one year.

An Organ may be returned after six months at cost of only reasonable rent, if for any reason it is not wanted longer. If an Organ be retained, and rent paid four years, it becomes the property of the party hiring, without further payment.

Organs will be rented on this plan to any part of the country accessible to our warehouses or agencies. Only knowledge of the unrivaled excellence of our Organs, and practical experience that they will be found so attractive in use that scarcely any of them will ever be returned, warrant this offer to supply them on such terms.

Terms of Renting, containing full particulars, with descriptions of Styles, Rents, and Prices; also, Illustrated Catalogues and Testimonial Circulars, sent Free. Address

MASON & HAMLIN ORGAN CO.
BOSTON, NEW YORK, OR CHICAGO.

BAIRD'S BOOKS

For Practical Men.

My new revised and enlarged Catalogue of PRACTICAL AND SCIENTIFIC BOOKS, 96 pages, 8vo., will be sent, free of postage, to any one who will favor me with his address.

HENRY CAREY BAIRD,

Industrial Publisher,

406 Walnut St., Philadelphia.

Scribner's Lumber & Log-Book.

OVER HALF A MILLION COPIES SOLD. This book is the most full and complete book of its kind ever published. It gives correct measurement of all kinds of lumber, logs, plank, cubical contents of square and round timber, stave and heading bolt tables, wages, rent, board, capacity of cisterns, cord-wood tables, interest, etc., and has become the Standard Book throughout the United States and Canada.

Be sure and get the New Edition, with Doyle's Log-Table. Ask your bookseller for it, or I will send one for 35 cents, post-paid. G. W. FISHER, P. O. Box 233, Rochester, N. Y.

WANTED AGENTS—for Dr. Cornell's *Dollar Family Paper*—Religion and Health united—A splendid premium to every subscriber—noting like it in the country—a rare chance—particulars free. B. B. RUSSELL, Publisher, Boston, Mass.

WANTED! CANVASSERS for the *Farmer and Gardener*, Lancaster, Pa. Large commission and premiums given. Send 25 cents for an Agency Subscription. Samples 6 cents.

In the Fields again with Prof. Gray.

BOTANY.

Standard Text Books,

BY

Prof. ASA GRAY of Harvard.

MORE EXTENSIVELY USED THAN ALL OTHER BOTANICAL SERIES COMBINED.

HOW PLANTS GROW. A complete and charming elementary work. Price \$1.12.

LESSONS IN BOTANY and Vegetable Physiology, to which is added a copious Dictionary of Botanical Terms. Fully Illustrated. Price \$1.30.

SCHOOL AND FIELD BOOK. A most popular and comprehensive School Book. This work, in connection with "How Plants Grow," supplies a complete course in Botany for Common Schools, Academies, and Seminaries. 622 pages. Price \$2.50.

MANUAL OF BOTANY. For higher grades and Colleges. 700 pages. Price \$2.25.

The same, with *The Lessons*. Price \$3.00.

The same, with *Mosses and Liverworts*. Price \$3.75.

STRUCTURAL and SYSTEMATIC BOTANY, with 1,300 woodcuts. 556 pages. Price \$3.50.

* * * We will send single copies of either or all of the above, if desired for examination with a view to introduction, on receipt of half the appended prices. The most liberal terms will be given for introduction.

Full Descriptive Circulars of Gray's Botany, with many testimonials from eminent scientists and teachers, by mail on application. Address

IVISON, BLAKEMAN, TAYLOR & CO.,

EDUCATIONAL PUBLISHERS,

138 & 140 Grand St., New York.

The Rural Kansan

Published monthly, at Humboldt, Kansas, at \$1 per annum, contains 32 large columns, 3 columns to the page, and is the only publication in the country that has a large department devoted exclusively to

Land Question,

in which the laws, decisions, and rulings relating to the various Acts of Congress for the disposal of the public lands are published, and all questions of inquiry relating to lands in the West answered without charge.

It is invaluable to those desiring to avail themselves of the Homestead, Pre-emption, or other Acts of Congress.

Send 10 cents for specimen copy. Address

RURAL KANSAN, Humboldt, Kansas.

A SUCCESSFUL BOOK.—The *New York Evening Post* says: "We learn from the best authority that the amount paid to the heirs of William H. Seward for copyright of the first six months of *Seward's Travels Round the World*, was over *Forty-one Thousand Dollars*. The second six months began on the 1st of August, and the sale of the work continues constant and large. Such a profit for such a time is probably without a parallel in this country, if it has ever been equaled anywhere." * * * The above work makes a large and handsome Octavo of 800 pages, and 200 illustrations. It is sold only by Subscription, and is the best selling book of the day.

A few desirable Agents can secure good territory by applying soon to the publishers.

D. APPLETON & CO.,

549 and 551 Broadway, New York.

AGENTS WANTED FOR THE CENTENNIAL GAZETTEER OF THE UNITED STATES.

A complete encyclopædia of all the States, counties, townships, cities, villages, post-offices, mountains, rivers, lakes, etc., with their climate, population, agriculture, manufacturing, mining, commerce, railroads, capital, education, government, and history, showing the gigantic results of the FIRST 100 YEARS of the REPUBLIC.

Agents make \$100 to \$300 per month. Send for circular. ZIEGLER & M'CURDY, Philadelphia, Pa.; Cincinnati, O.; St. Louis, Mo.; Springfield, Mass.; Chicago, Ill.

"EDEOGRAPHY" A new book on the art of writing by sound; a complete system of Phonetic Short Hand—the shortest, most simple, easy, and comprehensive, enabling any one, in a short time, to report trials, speeches, sermons, &c. The Lord's Prayer is written with forty-nine strokes of the pen, and 140 words per minute. The unemployed should learn this art. Price, by mail, 50 Cts. Agents wanted. Address T. W. EVANS & CO., 139 S. Seventh Street, Phila., Pa.

STEEL PENS!
Sold by all Dealers.
No. 91 JOHN ST., NEW YORK.
HENRY HOE, Sole Agent. JOSEPH GILLOTT & SONS

AGENTS WANTED for the HOPE SEAT SPRING throughout the United States. Send for circular. BENJ. F. WELLS, 47 Dey Street, New York.

FIFTY Fine Flowering Plants

FOR TEN DOLLARS, BY EXPRESS.

Comprising 25 varieties of choice Bedding Plants, Roses, etc., as follows:

- 3 Geraniums, including Master Christine, Jean Sisley, or Mrs. Pollock.
- 3 Roses, including Bon Silene or Saffrona.
- 2 Heliotropes.
- 2 Pyrethrum or Golden Feather.
- 2 Pentstemons—newest best varieties.
- 2 Amaranthus Monstrosus.
- 2 Dianthus Chincensis.
- 2 Mesembryanthemum Pomeridianum.
- 2 Lobelias—choice dwarf.
- 2 Fuchsias.
- 2 Pansies—best English show and bedding.
- 2 Stocks, Intermediate.
- 2 Sweet Williams—Scotch seedlings.
- 2 Wall Flowers—Scotch Seedlings.
- 2 Hollyhocks—European seedlings.
- 2 Agrostemas.
- 2 Lark Spurs, black and blue.
- 2 Verbenas.
- 2 Irisingas.
- 2 Stock Gillflowers—French.
- 2 Tropæolums.
- 2 Coleus, golden and velvet.
- 2 Petunias.
- 1 Calceolaria.
- 1 Cineraria.

Where parties may desire but one plant each, of the above 25 varieties named, I will express same for \$6, or mail them at \$8, prepaying postage.

The above are thrifty and well-grown plants, from seeds and stock carefully selected by the proprietor while traveling last summer and fall for his health, in England, France, Germany, Austria, and Italy. We have also a full stock of Azaleas, Camellias, Begonias, Carnations, Lilies, etc., which will be furnished to patrons at moderate prices. We are also growing many novelties from seeds we brought over, including the new ornamental Chilian Beet. We are also receiving an importation of choice Orchids, Dracænas, Caladiums, etc. Also, the newest Geraniums, Fuchsias, etc., which will be for sale next season. Price-Lists free on application.

SAM'L GREIVES,

MANAGER GREENBROOK NURSERIES,

Near Paterson, N. J.

P. O. Address, Box 837, Paterson, N. J.

THE PATENT

ARION PIANO-FORTE

Excels all others in Tone and Durability, and in Elegance of Finish they are Unsurpassed.

These Pianos are used exclusively in the New York Conservatory of Music, and are recommended by the Professor and the Press throughout the United States.

Before purchasing, write for Illustrated Pamphlet, and mention the *Agriculturist*.

ARION PIANO-FORTE CO.,

No. 5 East 14th Street, New York City.

DO YOU LOVE MUSIC?

If so, send us your address and the names of your musical friends, to whom we will mail, post-paid, our new Descriptive CATALOGUE of choice MUSIC and specimen copies of the "MUSICAL WORLD," containing \$1.00 worth of Music.

S. BRAINARD'S SONS, Cleveland, Ohio.

FARMS IN VIRGINIA,

With Dwellings, Barns, etc. Vegetation for New York markets four to six weeks earlier than New Jersey lands.

Quick and Cheap Steam Transportation to All the Northern Markets.

Prices \$5 to \$25 per acre. Farms both large and small. Lists with full particulars by addressing

WM. P. MOORE & CO., Suffolk, Va.

WANTED—Agents—\$75 to \$250

per month, everywhere, male and female, to introduce the GENUINE IMPROVED COMMON SENSE FAMILY SEWING MACHINE. This Machine will stitch, hem, furl, quilt, cord, bind, braid, and embroider in a most superior manner. Price only \$15. Fully licensed and warranted for five years. We will pay \$1,000 for any machine that will sew a stronger, more beautiful, or more elastic seam than ours. Address SECOMB & CO., Boston, Mass.; New York City; Pittsburgh, Pa.; Chicago, Ill.; or St. Louis, Mo.

AGENTS LOOK!—\$12 a day made selling A Scissors Sharpener and other wares. Sample 25 cts. Catalogue free. T. J. HASTINGS & CO., Worcester, Mass.

DO GOOD

AND

MAKE

MONEY.

The Publishers of American Agriculturist and HEARTH AND HOME take pleasure in presenting in the adjoining Table, their new general Premium List for 1874. The Premiums which they have offered in past years have engaged the attention of a very large number of persons of all ages and both sexes. Many thousands have secured Premiums, and very many of these, who at first had small hopes of success, have been themselves astonished at the ease with which they have raised large clubs and secured valuable Premiums.

Here is pleasant and profitable work for all. Any one who wishes to do good and make money, can do both by going to work as here invited by the publishers of these two most valuable journals, American Agriculturist and HEARTH AND HOME. You need only to show specimens of the papers, promise the beautiful Chromos, which are now ready for delivery, according to the publishers' offer, and forward your subscriptions. TRY IT.

Explanatory Notes.

N. B.

Read and carefully

Note the following items: (a) All subscribers sent by one person count, though from one or a dozen different Post-offices. But... (b) Tell us with each name or list of names sent, that it is for a premium... (c) Send the names as fast as obtained, that the subscribers may begin to receive the paper at once. You can have any time, from now until July 1st, to fill up your list... (d) Send the exact money with each list of names, so that there may be no confusion of money accounts... (e) Old and new subscribers all count in premium clubs, but a portion, at least, should be new names; it is partly to get these that we offer premiums to canvassers... (f) Specimen Numbers, etc., will be supplied free as needed by canvassers, but they should be used carefully and economically, and where they will tell... (g) Remit money in Checks on New York Banks or Bankers, payable to order of Orange Judd Company, or send Post-office Money Orders. If neither of these is obtainable, Register Money Letters, affixing stamps both for the postage and registry; put in the money and seal the letter in the presence of the Postmaster, and take his receipt for it. Money sent in any of the above ways is at our risk; otherwise it is not.

[In the following table is given the price of each article, and the number of subscribers required to get it free, at the regular rates, \$1.50 a year for American Agriculturist, and \$3.00 a year for Hearth and Home; also at the club rates of \$1 and \$2.50; also at the rates of \$1 a year for both papers together.] Description of Premiums sent free to applicants.

N. B.—In all Premium Clubs for either paper, TWO copies of American Agriculturist (English or German) at \$1.50 each, and ONE copy of Hearth and Home at \$3.00, will count exactly the same. So also two copies of American Agriculturist at \$1 each, and one copy of Hearth and Home at \$2.50, will count exactly the same. In this way Premium Clubs can be made up from the 2d and 4th columns, or from the 3d and 5th, or wholly from the 6th column.

Table of Premiums and Terms For American Agriculturist, and for Hearth and Home, for the Year 1874. Open to all—No Competition.

Table with 6 columns: (1) No., (2) Names of Premium Articles, (3) Price of Premiums, (4) American Agriculturist only, (5) Hearth and Home only, (6) Both Papers together. Includes items like Moore's Floral Set, Gold Pen, Revolving Pencil, Butter Cooler, Knives and Forks, Sewing Machine, etc.

Every Premium article is new and of the very best manufacture. No charge is made for packing or boxing any article in our Premium List. The Premiums, Nos. 2 to 8, 27 to 33, 55 to 78, and 81 to 93, inclusive, will each be delivered FREE of all charges, by mail or express (at the Post-offices or express office nearest the recipient) to any place in the United States or Territories.—The other articles cost the recipient only the freight after leaving the manufactory of each, by any conveyance desired. Description of Premiums sent free to applicants.

Up for Repairs,

A Beautiful, New Picture FOR EVERY SUBSCRIBER

TO THE American Agriculturist FOR 1874.

The great satisfaction which has been expressed by tens of thousands of subscribers to this paper who have received the picture entitled "Mischief Brewing," has led the Publishers to provide another beautiful Gift for their patrons for the coming year.

An exquisite Oil Painting by the celebrated American Painter, Mr. B. F. Reinhart, executed expressly for the American Agriculturist and entitled

"UP FOR REPAIRS,"

has been most successfully reproduced in Chromo by the well-known firm of Bencke & Scott. It is a picture of a scene in childhood, which many will recognize as what they have themselves witnessed or been actors in, and can not fail to please both old and young. The Chromo is so perfectly done as scarcely to be distinguished from the original.

The Publishers will give this beautiful Chromo

To Every Subscriber

to this paper for the year 1874 received after this date, as detailed below. It is ready for immediate delivery at 245 Broadway, Free of Charge.

If to go by mail, 10 cents must be sent to cover cost of packing and postage. For 25 cents it will be Mounted, Varnished, Packed, and sent Post-paid.

N. B.—The Chromo will be delivered: At the Office, Unmounted, Free. " " Mounted, 15 cents extra. Sent by Mail, Unmounted, 10 cents extra. " " Mounted, 25 cents extra.

We advise all to have them mounted before leaving the office, as in the large quantities we put up we are able to mount them for a quarter of the cost of doing it singly, and better than it can usually be done elsewhere.

The picture is designed for every subscriber upon the terms stated above, which please read carefully; and on these terms all are alike entitled to it, whether their names come singly at \$1.50 each, or in Clubs of Four for \$5, or Clubs of Ten at \$1.20 each, or in Clubs of Twenty or more at \$1 each. Subscribers in Premium Clubs will also thus be entitled to it.

N. B.—A few of the beautiful pictures entitled "MISCHIEF BREWING," which have been given to so large a number of subscribers, are still in stock, and, while any remain, subscribers to the American Agriculturist can have their choice between this and the new Chromo "UP FOR REPAIRS;" but the choice must be named at time of subscribing.

ORANGE JUDD COMPANY, 245 BROADWAY, NEW YORK.

Play and Profit IN MY GARDEN.

By E. P. ROE, Author of "Barriers Burned Away," etc.

CONTENTS.

Table with 2 columns: CHAP. and Description. Includes items like Will you Walk into my Garden?, My Garden Accounted for, My Garden—Its Location, etc.

PLANTS

For Everybody.

PLANTS

By Mail, without Cost for
Packing or Postage.

WE SEND

12 superb Verbenas , 12 colors,	\$1.00
6 Monthly Tea-Roses , 6 colors,	1.00
6 other Roses , assorted,	1.00
6 choice Geraniums , 6 colors,	1.00
6 fragrant Geraniums ,	1.00
6 handsome Coleus , distinct sorts,	1.00
6 Heliotropes , 6 sorts,	1.00
6 choice foliage Begonias ,	1.00
6 choice flowering do.,	1.00
6 choice Chrysanthemums ,	1.00
6 choice Dahlias ,	1.00
6 Lady Washington or Show Geraniums ,	1.00
6 choice Phloxes ,	1.00
6 choice Perpetual Carnations ,	1.00
6 ornamental foliage Bedding Plants ,	1.00
10 Plants for Hanging Basket ,	1.00
6 splendid Fuchsias ,	1.00
6 choice Bouvardias ,	1.00

We grow no inferior varieties, but the selection of sorts at the above rates must in a great measure be left to us.

WE ALSO OFFER

The new variegated **Ice-Plant**, **La Belle Carnation**, 6 new and beautiful **Coleus**, new **Fuchsias**, **Dahlias**, **Chrysanthemums**, and many other new, rare, and beautiful **Plants**, for full descriptions of which, with a full collection of **Greenhouse**, **Bedding**, and **Window Plants** see our new Catalogue of 96 pages.

We are now sending our **Plants** to every part of the United States and Canadas. By **mail** and **express** they reach their destination in perfect safety. Here is a letter to the point just now come to hand:

NEW LENOX, WILL CO., ILL., Feb. 13, '74.

H. E. CHITTY—DEAR SIR: The Geraniums arrived last evening in perfect order; not wilted nor dry—as fresh as when first started, and not a leaf broken.

Yours truly,

MRS. N. GOUGAR.

The above is an example of letters daily received.

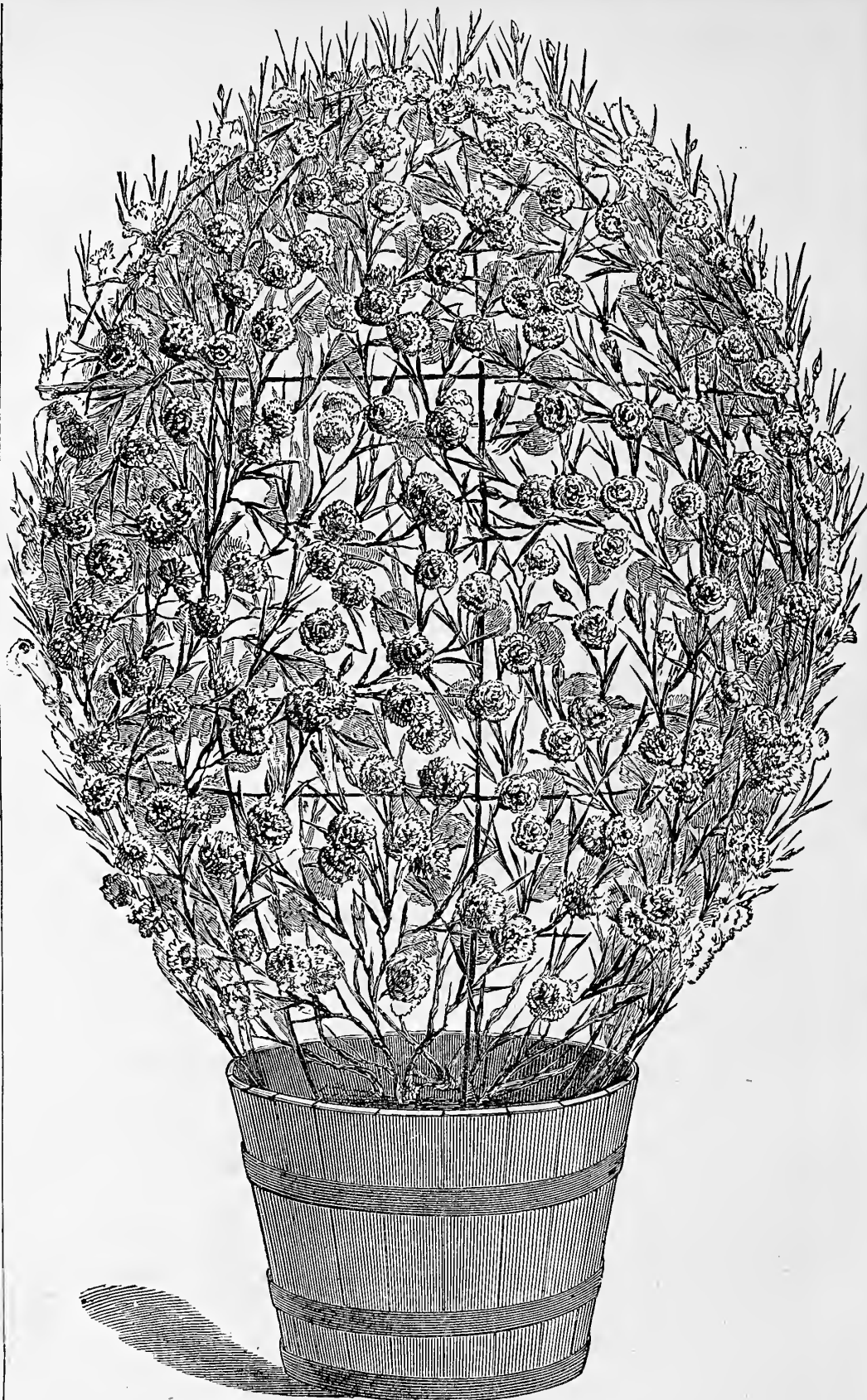

La Belle Carnation.

For our CATALOGUE inclose Letter-Stamp to the

BELLEVUE NURSERY COMPANY

PATERSON, NEW JERSEY.

HENRY E. CHITTY, Supt.

BOOKS FOR FARMERS and OTHERS.

Published and for sale by the Orange Judd Company, 215 Broadway, New York. Any of these books will be forwarded by mail post-paid, on receipt of price.]

Table listing various agricultural books with authors and prices. Includes titles like 'American Cattle', 'Rural Architecture', 'Diseases of Domestic Animals', etc.

Table listing books for stock-keepers with authors and prices. Includes titles like 'Youatt and Martin on Cattle', 'Youatt on the Hog', 'Youatt on Sheep', etc.

FRAMES FOR THE CHROMOS.

We have made arrangements to supply frames to our subscribers who may desire them for the Chromos which are now being distributed. Many will no doubt avail themselves of this opportunity to place these beautiful pictures in handsome frames at moderate cost.

For American Agriculturist Chromo, "UP FOR REPAIRS,"

Or for Hearth and Home Chromo, "LOOK OUT!"

Table listing prices for different frame styles and sizes, such as 'Letter A. Neat Black-Walnut Frame, Gilt Band'.

For American Agriculturist Chromo, "MISCHIEF BREWING."

Table listing prices for different frame styles and sizes for the 'Mischief Brewing' chromo.

For Hearth and Home Chromo, "THE STRAWBERRY GIRL."

Table listing prices for different frame styles and sizes for the 'The Strawberry Girl' chromo.

Address orders, specifying by its letter or number the frame desired, and inclosing price, as above, to the ORANGE JUDD COMPANY, 245 BROADWAY, NEW YORK.

Money IN THE GARDEN. A VEGETABLE MANUAL, PREPARED WITH A VIEW TO ECONOMY AND PROFIT, BY P. T. QUINN, PRACTICAL HORTICULTURIST.

In this work the author aims to give, in a plain, practical style, instructions on three distinct though closely connected branches of gardening—the kitchen-garden, market-garden, and field culture; the only and sufficient credentials for the fitness of his undertaking being a successful practical experience for a term of years.

Table of contents for 'Money in the Garden', listing chapters I through VII and their respective topics like 'Money in the Garden', 'Hot-beds', etc.

PRICE, POST-PAID - - - - - \$1.50 Either of the above books sent post-paid on receipt of price by

ORANGE JUDD COMPANY, 245 BROADWAY, NEW YORK.

PRETTY MRS. GASTON, AND OTHER STORIES.

BY J. ESTEN COOKE, Author of "The Virginia Comedians," "Dr. Van Dyke," "Surry of Eagle's Nest," etc.

CONTENTS.

Table of contents for 'Pretty Mrs. Gaston', listing chapters 1 through 33 and their respective titles.

ILLUSTRATIONS.

Mr. Jobson Protests.—"I Am a Beggar, Marian—a Beggar!"—Annie Bell Stopped and Turned Round—a Statue of Surprise.—"Oh! Mr. Daintrees!"—"Good Morning, Sir!" said Marian, Rising.—"His Health!"—"No Offence Is Meant by Either Gentleman, I am Sure."—Cries were Heard One or Two Hundred Yards in Front of the Hollies.—"Your Father, Miss?"—The Prying Moon—What It Lingered upon Now.—The Individual Resembling a Bull-dog had Listened.

ANNIE AT THE CORNER. CONTENTS.

Table of contents for 'Annie at the Corner', listing chapters 1 through 9.

The Wedding at Duluth.

Price, Post-paid, \$1.50. ORANGE JUDD COMPANY, 245 BROADWAY, NEW YORK.

UNION PACIFIC R.R. CO.

HAVE A LAND GRANT OF
12,000,000 ACRES!

OF THE BEST MINERAL AND FARMING LANDS OF AMERICA.

4,250,000 ACRES IN THE STATE OF NEBRASKA.

**3,000,000 ACRES in Central and Eastern Nebraska,
IN THE GREAT PLATTE VALLEY,
THE GARDEN OF THE WEST,**

NOW FOR SALE AT PRICES THAT DEFY COMPETITION.

Cheap Lands—The Best Investment.

No fluctuations! Always Improving in Value! The Wealth of the Country is made by the Advance in Real Estate! These lands are located on the 41st Degree of North Latitude, in the

Great Central Belt of Population, Commerce, and Wealth.

Have a mild and healthy climate, and for Grain and Fruit Growing and Stock Raising are unsurpassed by any in the United States.

The Best Market in the West,

The great Mining Regions of Wyoming, Colorado, Utah, and Nevada being supplied by the farmers of the PLATTE VALLEY.

Cheaper in Price and More Favorable Terms Given than can be Found Elsewhere.

Five and Ten Years' Credit Given, with Interest at Six per Cent.

NO ADVANCE INTEREST REQUIRED. Colonists and Actual Settlers can buy on Ten Years' Credit. Lands at same price to all Credit purchasers. Prices range from \$2.00 to \$10.00 per Acre. A Deduction of Ten per Cent for Cash. The Land Grant Bonds of the Company are taken at par in payment for the Lands.

Free Homesteads for Actual Settlers. The Best Locations for Colonies.

SOLDIERS OF THE LATE WAR are entitled to a **FREE HOMESTEAD OF 160 ACRES** within Railroad Limits, which is equal to a **DIRECT BOUNTY OF \$400. DO NOT DELAY. NOW IS THE TIME TO SECURE A HOME.** Free Passes to Purchasers of Railroad Lands. Buy Through Tickets Direct to Omaha, Nebraska.

Sectional Maps, showing Lands for sale, with the prices corrected up to the latest date, also Descriptive Pamphlet with new maps published in ENGLISH, GERMAN, SWEDISH, DANISH, FRENCH, DUTCH, and BOHEMIAN, furnished gratuitously on application to the Land Department, or mailed free to any address. "THE PIONEER" is also sent FREE to applicants IN ANY PART OF THE WORLD. Address

O. F. DAVIS, Land Commissioner U. P. R.R., OMAHA, NEB.

WOOD, TABER & MORSE, Eaton, Madison Co., N. Y.

MANUFACTURERS OF

Steam-Engines,

Portable, Stationary, and Agricultural.

Hundreds in use in Shops, Printing Rooms, Mills, Mines, and on Farms and Plantations for Grain Threshing, Food Cooking for Stock, Cotton Ginning, Sawing, etc. Circulars sent on application.

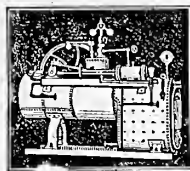

AN OPPORTUNITY TO OWN AN ORANGE GROVE without interference with present occupation.

AURANTIA GROVE, INDIAN RIVER. A combination of Groves of all sizes. Prices from \$50 up, including care.

Also, Unimproved Orange Land by the acre.

Ask those who have visited Florida about the profits of Orange Culture.

For Circulars address BLISS, HOOB & BENT, P.O. Box 5712, Office, 20 Murray St., New York City.

Cheese-Vats and Dairy Apparatus, with all kinds of Furnishing Goods for Factories, Creameries, and Private Dairies. The best articles and at the lowest rates. Send for new illustrated circular and price-list. CHARLES MILLAR & SON, Utica, N. Y.

PLANTS—PLANTS. — Affected by the late Panic in Prices only. See page 111, last number *Am. Agriculturist*, and address. JOHN S. COLLINS.

PEAR CULTURE

FOR PROFIT.

By P. T. QUINN,

PRACTICAL HORTICULTURIST.

ILLUSTRATED.

If one wishes to raise pears intelligently, and with the best results, he must know first the character of his soil, the best mode of preparing it, the best varieties to select under existing conditions, the best mode of planting, pruning, fertilizing, grafting, and utilizing the ground before the trees come into bearing, and finally, of gathering and packing for market.

The hope of furnishing practical information on all these points has induced the author to endeavor to draw for others the same lessons which years of practical experience have afforded him.

Contents:

Chap. I. Varieties.	Chap. IX. Varieties to Plant.
“ II. Aspect.	“ X. Pruning.
“ III. Preparation of the Soil.	“ XI. Manuring and Mulching.
“ IV. Distance Apart in Planting.	“ XII. Gathering Fruit.
“ V. Dwarfs and Standards.	“ XIII. Marketing Pears.
“ VI. Planting-Time.	“ XIV. Profits.
“ VII. Nursery Trees.	“ XV. Propagation, etc.
	“ XVI. Practical Suggestions.
	“ XVII. Orchard Record.

PRICE, POST-PAID.....\$1.00

ORANGE JUDD COMPANY,
245 BROADWAY, NEW YORK.

BOOKS ON ARCHITECTURE.

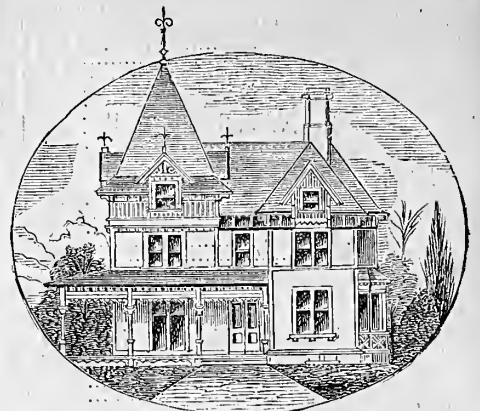

A Practical Book, one that Architects, Builders, and Carpenters can not afford to be without, entitled

DETAIL, COTTAGE, AND CONSTRUCTIVE ARCHITECTURE,

Containing 76 FULL PLATES, 20 plates more than before offered in a similar work for Ten Dollars.

Published under the direction of A. J. BICKNELL.

Showing a great variety of Designs for Cornices, Brackets, Windows and Window Caps, Doors, Piazzas, Porches, Bay and Dormer Windows, Observatories, Towers, Chimney Tops, Balconies, Canopies, Scrolls, Gable and Sawn Ornaments, Fences, Stairs, Newels, Architraves, Mantels, Plaster Finish, etc.; including Forty-five Perspectives, Elevations and Plans of Modern Designs for Cottages with Details, and Eighteen Elevations of Summer Houses, Villas, Seaside Cottages, and Country Houses, together with Fourteen Designs for Street and Store Fronts, with Inside Finish for Stores and Banks; also, Framing for Dwellings, Barns, Exhibition Buildings, Roofs, Bridges, etc., etc., making in all a Practical Book for Architects, Builders, Carpenters, and all who contemplate Building or Remodeling Wood, Stone, or Brick Buildings. One Large Quarto Volume, sent Free by Mail or Express, on receipt of Price.....\$10.00.

Bicknell's Village Builder, And SUPPLEMENT.

THE VILLAGE BUILDER shows Elevations and Plans for Cottages, Villas, Suburban Residences, Farm Houses, Stables and Carriage-Houses, Store Fronts, School-Houses, Churches, Court-Houses, and a Model Jail. Also, Exterior and Interior Details for Public and Private Buildings, with approved Forms for Contracts and Specifications, containing fifty-five Plates, drawn to Scale, giving the Style and Cost of Building in different sections of the Country. Revised Edition, with three additional Plates, showing Inside Finish for Stores, Banks, and Insurance Offices, and two Elevations and Plans for low-priced Dwellings; also, a variety of Details added to several Plates. Quarto Volume, issued February 1, 1872. THE SUPPLEMENT contains Twenty Plates, showing Eighteen Modern and Practical Designs for Country and Suburban Residences of moderate cost, with Elevations, Plans, Sections, and a Variety of Details, all Drawn to Scale. Also, a Full Set of Specifications, with Approved Form of Contract and Estimates of Cost. The Two Books in one Volume, price.....\$12.00. Parties desiring the Supplement only, will be supplied, post-paid, on receipt of \$5.00.

ARCHITECTURE.

By CUMMINGS & MILLER.

A Practical Book on Architectural Details; containing over One Thousand Designs and Illustrations, showing the manner of constructing Cornices, Doorways, Porches, Windows, Verandas, Railings, French Roofs, Observatories, Piazzas, Bay-Windows, Cut-Stone Work, various styles of Modern Finish, and Street Fronts of Houses, Stores, etc., etc. One Large Quarto Volume. Price, post-paid....\$10.00.

Modern American Architecture.

By CUMMINGS & MILLER.

Containing Designs and Plans for Villas, Farm-Houses, School-Houses, Cottages, City Residences, Churches, etc. Also, Trussed Roofs, Interior Store Finish, and many Exterior Details. In One Large Volume, bound in Cloth, 54 Plates, price.....\$10.00.

Loth's Practical Stair-BUILDER.

A complete Treatise on the Art of Building Stairs and Hand-Rails. Designed for Carpenters, Builders, and Stair-Builders. Illustrated with Thirty Original Plates. By C. EDWARD LOTH, Professional Stair-BUILDER. One large Quarto Volume. Bound in Cloth. Price.....\$10.00.

Address

ORANGE JUDD COMPANY,
245 BROADWAY, NEW YORK.

MAY, 1874.

AMERICAN

AGRICULTURIST

FOR THE FARM, GARDEN & HOUSEHOLD.



Vol. XXXIII

Number 5

PUBLISHED BY THE
ORANGE JUDD COMPANY,
 245 BROADWAY,
 NEW-YORK.



SUPERIOR STANDARD WORKS.

Published by **ORANGE JUDD COMPANY.**

THE HORSE.

**FRANK FORESTER'S
HORSE OF AMERICA.**



By **HENRY WM. HERBERT.**

Revised, corrected, enlarged, and continued to 1871,
By **S. D. and B. G. BRUCE.**

Always an **ACKNOWLEDGED STANDARD**, and now
the **MOST COMPLETE** and **AUTHENTIC** Work on the
HORSE. With steel-engraved portraits of Thirty
of the most famous

REPRESENTATIVE HORSES,
including pedigrees, histories, and performances.
Two superb royal octavo volumes of upward of 1300 pages.
Post-Paid, Ten Dollars.



**WALLACE'S
American Trotting Register.**

CONTAINING ALL THAT IS KNOWN OF THE

PEDIGREES OF TROTTING HORSES,

their ancestors and descendants, with a record of
All published performances in which a mile
was trotted or paced in 2.40 or less,
from the earliest dates until the close of 1868, and
a full record of the performances of 1869 and 1870.
Giving complete Summaries of over 6,000 Contests.

With an **INTRODUCTORY ESSAY** on the true
origin of the American Trotter. And a set of Rules
for the government of all trials of speed. By **J.
H. WALLACE**, compiler of Wallace's American
Stud-Book. Royal octavo.

Post-paid, Ten Dollars.

WALLACE'S AMERICAN STUD-BOOK.

VOL. ONE. BEING A COMPILATION OF THE

**PEDIGREES OF AMERICAN AND IM-
PORTED BLOOD HORSES,**

from the earliest records, with an **APPENDIX** of all
named animals without extended Pedigrees prior
to the year 1840. And a **SUPPLEMENT**, containing a
history of all Horses and Mares that have trotted
in public from the earliest trotting races until the
close of 1866. By **J. H. WALLACE**. Royal octavo
of over 1000 pages elegantly bound in extra cloth,
beveled boards, and splendidly illustrated.

Post-paid, Ten Dollars.

Horse Portraiture. — BREEDING,

REARING, AND TRAINING TROTTERS. Prepara-
tions for Races, Management in the Stable, on
the Track, Horse Life, etc. By **JOSEPH CAIRN
SIMPSON**. Post octavo. Post-paid, \$3.00.

FIELD SPORTS.



Frank Forester's Field Sports.

Embracing the Game of North America, Upland Shoot-
ing, Bay Shooting, Wild Sporting of the Wilderness,
Forest, Prairie, and Mountain Sports, Bear Hunting,
Turkey Shooting, etc. 13th edition, revised and illus-
trated. Two post octavo volumes. Post-paid, \$6.00.

Frank Forester's Fish and Fishing.

100 engravings. Embracing a full illustrated description
of the Game Fish of North America; Trout and Salmon
Fishing; Shoal Water and Deep Sea Fishing; Lake and
River Fishing; Trolling, Fly Fishing, etc. 12th edition.
One post octavo volume. Post-paid, \$3.50.

Frank Forester's Complete Manual

For Young Sportsmen, of Fowling, Fishing, and Field
Sports. With directions for handling the Gun, the Rifle,
and the Rod. Art of Shooting on the Wing. The Break-
ing, Management, and Hunting of the Dog. The varie-
ties and habits of Game. River, Lake, and Sea Fishing.
Post octavo. Post-paid, \$3.00.

**Frank Forester's American Game in its
SEASONS, Fully Illustrated and Described. New edi-
tion, post-paid, \$3.00.**

The Dog.

By **Dinks, Mayhew & Hutchinson**. Compiled and edited
by **Frank Forester**. Containing full instructions in all
that relates to the Breeding, Rearing, Breaking, Kennel-
ing, and Conditioning of Dogs, with valuable recipes for
the treatment of all diseases. Illustrated. Post octavo.
Post-paid, \$3.00.

The Dead Shot:

Or, Sportsman's Complete Guide; a Treatise on the use
of the Gun, with Rudimentary and Finishing Lessons in
the Art of Shooting Game of all kinds. By **Marksmen**.
Post-paid, \$1.75.

The Crack Shot:

Or, Young Rifleman's Complete Guide; being a Treatise
on the use of the Rifle, with Lessons, including a full de-
scription of the latest improved breech-loading weapons;
rules and regulations for Target Practice, and directions
for Hunting Game. By **Edward C. Barber**. Post-paid, \$1.75.

Gun, Rod, and Saddle.

Nearly fifty practical articles on subjects connected with
Fishing, Shooting, Racing, Trotting, etc. Post-paid, \$1.

Practical Trout Culture.

By **J. H. Slack, M. D.**, Commissioner of Fisheries, New
Jersey. Fully illustrated and describing thoroughly all
that is requisite to successful Trout Culture. Post-paid,
\$1.50.

AGRICULTURE.

Woodward's Graperies and Horticultural

BUILDINGS. Designs and Plans of Hot-beds, Cold Pits,
Propagating Houses, Seeding Houses, Hot and Cold
Greenhouses, Conservatories, Orchard Houses,
etc., with the various modes of Ventilating and Heating.
Post-paid, \$1.50.

Jacques' Manual of the Garden, Farm,

AND BARN-YARD. Embracing the Cultivation of
Vegetables, Fruit, Flowers, all Field Crops, Details of
Farm Work and Rearing Domestic Animals. New and
Revised Edition. One volume. Post-paid, \$1.75.

Young Farmer's Manual.

VOL. I. The Farm and the Workshop, with Practical
Directions for laying out a Farm, Erecting Buildings,
Fences, Farm Gates, Selecting good Farm and Shop
Tools, and performing Farm Operations. Fully illus-
trated. Post-paid, \$1.75.

Young Farmer's Manual.

VOL. II. How to Make Farming Pay, with full Details of
Farm Management, Character of Soils, Plowing, Manage-
ment of Grass Lands, Manures, Farm Implements, Stock,
Drainage, Planting, Harvesting, etc. Illustrated. Post-
paid, \$1.75.

Husmann's Grapes and Wine.

The Cultivation of the Native Grape and Manufacture
of American Wine. By **Geo. Husmann**, of Missouri.
Post-paid, \$1.50.

Elliott's Lawn and Shade Trees.

For Planting Parks, Gardens, Cemeteries, Private
Grounds, and Avenues. Fully Illustrated and described.
Post-paid, \$1.50.

Fuller's Forest Tree Culturist.

The Cultivation of Forest Trees for Shade, for Shelter,
for Fuel, for Timber, and for Profit. Illustrated. Post-
paid, \$1.50.

ORANGE JUDD COMPANY, 245 Broadway, N. Y.

THE BEST COMPANY

In which to obtain the Best Life Insurance upon the Best
Plan is (in our opinion) the **TRAVELERS INSURANCE
COMPANY**, of Hartford, Conn. Its rates are low, its
security is unquestioned, its management is prudent
and conservative, its reputation is first-class, it grants
life insurance of the very best quality upon rates and
conditions highly favorable to the insured. The con-
tract is plain and definite, without complication, mys-
tery, or uncertainty. The policy is always worth its face,
the premium never increases.

JAS. G. BATTERSON, President.
RODNEY DENNIS, Secretary.

CHAS. E. WILSON, Ass't Secretary.

GEO. B. LESTER, Actuary.

Agents everywhere.

RUPTURE.—Since the Elastic Truss, 683
Broadway, New York, which soon cures rupture, has
annihilated metal spring trusses, the finger-pad fellows steal
the name, and sell bogus elastic trusses, worthless rupture
belts, and stretchy "band trusses" to ignorant persons.
Beware of them. Highest medals at American Institute
and at the great Cincinnati Exposition. 28 branch offices.
Patronized by the Surgeon General and the U. S. Govern-
ment. This new truss is sent by mail at a cheap price, and
circulares furnished free by The Elastic Truss Co., 683 Broad-
way, New York.

INVENTORS Who wish to secure
PATENTS should
write to **MUNN &
CO., 37 Park Row,**
New York, for Advice and Pamphlet, 10s pages, FR12.

**PRETTY
MRS. GASTON,**

AND OTHER STORIES.

BY

J. ESTEN COOKE,

Author of "The Virginia Comedians," "Dr. Van Dyke,"
"Surry of Eagle's Nest," etc.

NOTICES BY THE PRESS.

The narrative is ever animated, and here and there touch-
ed with warm, tender, yet natural emotion. — *College
Cowan*, New Haven, Conn.

The principal figure of the story, the pretty widow Mrs.
Gaston, is well drawn and attractive, and the author has
displayed in the treatment of this character much care and
ingenuity. — *Boston Traveller*.

The style of Mr. Cooke's writings is smooth and fascinat-
ing, and whoever commences the perusal of them will never
regret the undertaking. — *Westfield News Letter*.

A romance with a most delightful complication of matrimo-
nial purposes, as well as having a villain, forger, gambler and
detective to assist in the action. — *Boston Post*.

The plot of the principal story is finely wrought out, full
of incident, and there is a sort of fascination about the style,
which claims the attention of the reader until the close. —
Salem Gazette.

A very lively and amusing book. — *Country Gentleman*.
The story is written in popular style—a little plot, a little
mystery, a little love—and is sure to attract a large number
of readers. — *Reading (Pa.) Eagle*.

Price, Post-paid, . . . \$1.50.

ORANGE JUDD COMPANY,

245 BROADWAY, NEW YORK.

ADVERTISING RATES.

American Agriculturist.

ENGLISH EDITION.

Inside Pages, \$1.50 per line (agate), each insertion.
Open Pages (open without cutting), \$2 per line.
Last Page, and 2d and 3d Cover Pages—\$2.50 per line.
Pages next to Reading and Last Cover Page—\$3.00 per line.
No advertisement inserted for less than \$5.00.

GERMAN EDITION.

Inside Pages, 25 cents per line, each insertion.
Business Notices and Last Page, 40 cents per line.
No advertisement inserted for less than \$1.00.

Hearth and Home.

Inside Pages, per line (agate), each insertion . . . 50 cents.
Business Notices, 7th Page, and Last Page . . . 75 cents.
Reading Notices per line . . . \$1 00.
No advertisement inserted for less than \$2.00.

No Advertisement of Medicines or Imbroglios received.
Address all orders to the

ORANGE JUDD COMPANY,

245 BROADWAY, NEW YORK.

AMERICAN AGRICULTURIST

FOR THE

Farm, Garden, and Household.

"AGRICULTURE IS THE MOST HEALTHFUL, MOST USEFUL, AND MOST NOBLE EMPLOYMENT OF MAN."—WASHINGTON.

ORANGE JUDD COMPANY,
PUBLISHERS AND PROPRIETORS.
Office, 245 BROADWAY.

ESTABLISHED IN 1842.

Published also in German at \$1.50 a Year.

{ \$1.50 PER ANNUM, IN ADVANCE.
SINGLE NUMBER, 15 CENTS.
4 Copies for \$5; 10 for \$12; 20 or more, \$1 each

Entered according to Act of Congress, in April, 1874, by the ORANGE JUDD COMPANY, at the Office of the Librarian of Congress, at Washington.

VOLUME XXXIII.—No. 5.

NEW YORK, MAY, 1874.

NEW SERIES—No. 328.

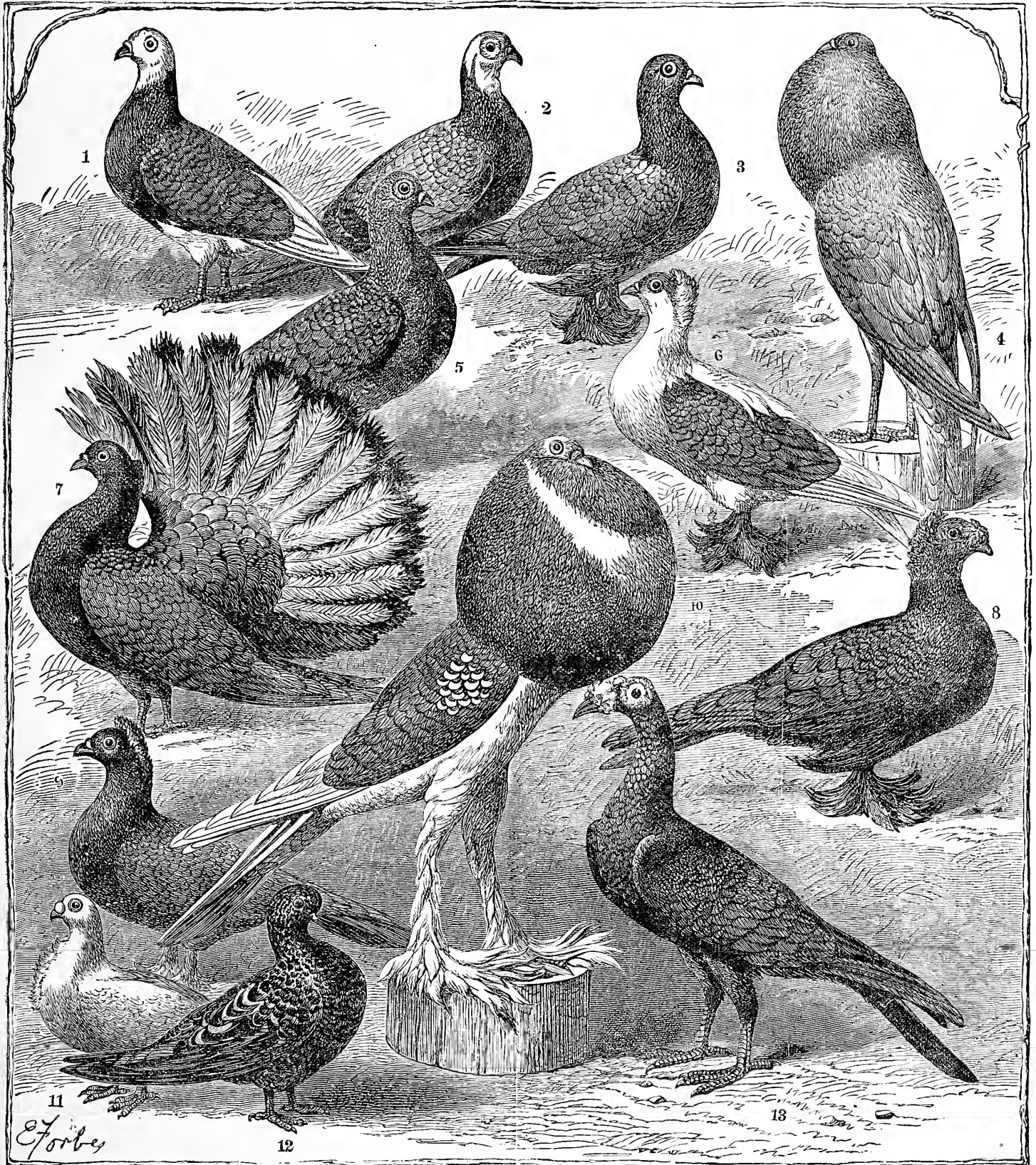

[COPYRIGHT SECURED.]

PIGEONS AT THE SHOW OF THE NATIONAL COLUMBARIAN SOCIETY.—(See page 171.)

Contents for May, 1874.

Animals—The Poitou Mare... Illustrated... 173
Animals—The Wild Ass... Illustrated... 173
Bee Notes... 170
Boys and Girls' Columns—The Doctor's Talks—Current Question—Aunt Sue's Puzzle-Box—Notices to Correspondents—An Impersonation—Making an Acquaintance... 3 Illustrations... 187, 188
Butter Factory... 4 Illustrations... 175, 176
Celery, Preservation of... 181
Cistern, Underground... Illustrated... 177
Crossing—Hybridizing... 3 Illustrations... 182
Ear-Marks for Stock... 3 Illustrations... 178
Farm Work for May... 162
Flowers—Enormous Arad—Amorphophallus... Ill... 181
Flower Garden and Lawn in May... 163
Fruit Garden in May... 164
Greenhouse and Window Plants in May... 164
Grist-Mill, A Shetland... Illustrated... 180
House Built of Sods... 2 Illustrations... 179
Household Department—About Paper-Hangings—Home Topics—Closets in the House—Town-People's Criticisms—Graham Gems—Chocolate Cake—Corn-Starch Cake... 5 Illustrations... 185, 186
Hurdles, How to Make... 2 Illustrations... 177
Implements—A Smoothing Drag... Illustrated... 178
Implements—The Grubber... 3 Illustrations... 176
Kentucky Blue-Grass... 171
Kitchen Garden in May... 163
Lard-Oil Press... Illustrated... 177
Market Reports... 164
Notes from the Pines—Forcing Plants—Greenhouse Pump—Primula Japonica, P. involucreta... 182
Ogden Farm Papers, No. 51—Large Yields of Butter—Feeding Dairy Cows—Mature—Abortion in Cows—Increased Sale of Jersey Bulls... 171, 172
Orchard and Nursery in May... 163
Pigeons—National Columbarian Society's Show... Illustrated... 161, 171
Plant—Indian Strawberry... Illustrated... 184
Plants—The Pale Corydalis... Illustrated... 183
Plants—The Vanilla Plant... Illustrated... 183
Poultry—Care of Young Chickens... 3 Illustrations... 177
Trees—Weeping Poplar... 181
Wagon Seat, An Easy... 2 Illustrations... 172
Walks and Talks on the Farm, No. 125—Corn Culture—Rotation—Laws and Gilbert's Experiments—Pasturing Pigs—Science in Farming—Wheat—Selling Timber—Mallows—Fattening Grade Lambs—Thomas Harrow... 174, 175

Calendar for May.

Table with columns for Day of Month, Day of Week, and sunrise/sunset times for Boston, New York, Philadelphia, Washington, and other cities.

PHASES OF THE MOON.

Table showing moon phases (Full, 3rd, New, 1st, Full) and times for Boston, N. York, Wash'n., Cha'ston, and Chicago.

AMERICAN AGRICULTURIST.

NEW YORK, MAY, 1874.

May is a busy month. In fact we know of no month in the year when a farmer can not find plenty of work that ought to be done. When we speak of winter being a season of comparative leisure, we simply mean that we can, if we choose, postpone our work for a few days or weeks. On a well-managed farm there is always work that can be done to advantage. Farmers often complain that their work is never done. We would not wish it otherwise. Without honest work there can be no honest pay. He that won't work neither shall he eat. How often does a man say, "if I could only get work I should be happy." A farmer need never say this. He is never in the condition of a briefless lawyer, or a minister without a charge, or a doctor without a patient. His store never leaks customers. His factory need never be run on half time. For this let us be thankful.

On our own farm, and we presume it is so on others, it is almost impossible to get ahead of the work. The seasons are short and the weather uncertain. The land is too wet to plow this week and too dry and hard to plow the week after. We must be prompt. We must be systematic and orderly. Plows, harrows, rollers, cultivators, drills, stone-boats, crow-bars, chains, spades, forks, wagons, carts, harness, bags, pails, baskets, ropes, whippletrees, elevators, bolts, monkey-wrench, ax, hammer, nails, and a score of other things that are likely or unlikely to be wanted should be all ready for use and just where you can lay your hand on them in the dark if needed. We must be ready at any moment to change from out-door to in-door work—to plow and harrow or grind hoes and oil harness; to draw off stones, sow plaster, build fence, dig, underdrain, or to eut feed, sort potatoes, repair tools, whitewash walls, or paint implements. To do all this without loss of time, and a hundred other things connected with good farming, requires a clear head, great patience, much self-denial, untiring energy, systematic and prompt industry, and constant personal supervision.

Hints about Work.

Horses need to be well looked after at this season. Much depends on their ability to do a good day's

work. They require not only good feed, but good digestion. Neither man nor horse can work well unless he eats well, sleeps well, and digests his food. Horses suffer more from indigestion than from any other one thing. At this season we are apt to keep them too many hours in the field. We know horses that are taken out to plow at six o'clock in the morning, are brought to the stable at noon, the bits taken out of their mouths, but the harness not removed. They are given a few ears of corn, and have some long, dry hay thrown into the racks; are again taken to the field at half-past one, and kept there until half-past seven at night. The horses are tired and exhausted when brought in at noon, and before there is time for the process of digestion to commence they are again put to hard work.

Three-Horse Teams are becoming more and more common, and can not be too earnestly recommended. A man can drive three horses as easily as he can two. Where it takes the strength of one horse to draw the empty wagon, three horses have double the effective force of two horses.

Plowing is often hard work. This is especially true in striking out the first furrow. In sod land we should always put on three horses, or else strike out a light, narrow furrow. On stubble land we throw up a light furrow and then turn it back again. This plows the whole land and does not overtax the team.

When the Horses are Brought Home at Noon give them a pail of water with a pint of corn or oatmeal stirred in it. Take off the harness. Wash the shoulders. If sweaty, rub them dry with straw, curry off the mud and dry sweat, and rub them down with a brush. Then feed them, and let them eat while you are at dinner.

Better Grooming in the stable and less idle time in the field is what we aim at on our own farm.

Cut Feed, moistened with water and mixed with meal and a little bran, can be eaten more rapidly than long hay, and leaves more time for rest and digestion. We mix a bushel of cut hay, four quarts of corn-meal, and two quarts of bran together, and let the horses have all they will eat of the mixture, and give them a little long hay in the racks.

Keep the Mangers Clean and Sweet.—As soon as the horse stops eating the cut feed remove all that is left from the manger. This is very important. Give a little salt in the manger every day. The horses will not eat too much if they have it regularly.

For Chafed Shoulders wash with warm soft water and castile soap and then dress with crude petroleum. If ulcerated, wash them with carbolic soap and apply petroleum afterwards. If possible, let the horse rest a few days.

Planting Corn is the important field work of the month. Corn is not likely to be as low next year as it has been for a year or two past. We think it a good time to plant freely.

Better Cultivation is, however, more desirable than a larger area. Wet land and weeds are the great enemies of the corn crop.

Early Planting is desirable, provided the land is warm and in good order.

On Rough Land we would plant in hills 3 1/2 or 4 feet apart. We can then cultivate both ways and clean and subdue the land with little hoeing.

On Clean, Smooth, Rich Land we think it pays to drill in the crop. When the stalks are valuable for fodder, and the land is rich enough, we are sure that drilling is more profitable than planting in hills.

Drilling has one great advantage. The work is not only done much more expeditiously and cheaply, but you can put in the seed every day as fast as the land is plowed and harrowed, and thus avoid delay from wet weather. A drill that would drop in hills so as to have the rows straight both ways would enable us to do the same thing, but we have never yet found a drill that will drop the seed exactly in the hills.

Wheat can be sown either broadcast or dropped

INDEX TO "BASKET," OR SHORTER ARTICLES.

Apples in Sawdust... 169 Lyons Hort. Exhib... 165
Ashes for Wheat... 167 Manures upon Poor Lands 167
Baking, Cure for... 167 Meat in Summer... 168
Beans for Feed... 167 Meat, Slow Killing of... 167
Bee Stings... 168 Mich. Bee Ass'n... 165
Black-Ash Shingles... 165 Milk, Curdy... 167
Bois d'Arc... 168 Milk Fever... 166
Bones... 167 Milk, Turnip Flavor in... 167
Bots in Horses... 166 Millet for Soiling... 167
Brahmas, Light... 167 Moles... 168
Bugs on Grapes... 165 Muzzle for Cribbers... 169
Buried Pork... 165 Newburgh Hort. Ex... 165
Butter for 3 cts. per lb... 168 Northern Spy in N. J... 168
Butter from Suet... 168 Old Roofs... 169
Butter from Sweet Cream 169 Patent Phosphate... 166
Butter-working Machin... Peach Prospects... 169
ery... 166 Peas... 167
Cabbages for Seed... 168 Pigs, Feed for... 167
Calf at Seven Months... 166 Plants by Mail... 165
Cancer in the Eye... 168 Plant Trouble... 168
Chicken Lice... 168 Plaster, Agricultural... 167
Chickens, Nests for Early 167 Plaster for Gardens... 167
China Geese... 169 Plow Mole or Drain... 168
Clevis, Three-Horse... 168 Pork in California... 169
Concrete Pipe... 169 Potato Blight... 168
Corn in Egypt... 168 Poultry House for Chicks 167
Corn, Shallow Plowing... 167 Poultry Yard... 167
Corn, Shrinkage of... 168 Prize Lawn Essays... 165
Corandum... 168 Reclaiming Swamp... 169
Cross-bred Fowls... 166 Rhubarb, Forcing... 168
Cross-bred Pigs... 169 Ruta-Bagas, After... 169
Croit Cabbage... 165 Scab... 169
Curculio... 169 Scab, Duration of... 167
Erasour... 169 Sheep and Lambs, Food... 167
Eggs all the Year... 166 Sheep, Cattail in... 167
Egg within an Egg... 168 Sheep in Orchard... 167
Flax... 169 Size of Acre... 165
Farm, Renting a Small... 168 Sorghum... 168
Flowers, Easter... 168 South Carolina, For... 168
Gardening for Profit... 165 Spent Hops... 166
Gate, Slide... 167 Stable Floors... 168
Harrow, Cultivating... 168 Stables... 169
Hennery Wanted... 168 Star Thistle... 169
Hogs, Coughing... 169 Sundry Insects... 168
Hogs, Poland China... 167 Swamp Muck... 169
Hops as Manure, Spent... 164 Swamp, Reclaiming... 169
Horse, Rough-Coated... 169 Swine-Breeders' Conven-
Horses, Hitching... 168 tion... 168
Horse Talk... 168 Time for Plaster... 169
Japan Pea... 169 Turkeys' Eggs... 167
Jersey and Alderney... 169 Underdraining... 169
Jerseys in Dairy... 169 Waste from Wool-Scour-
Lampass... 169 ing Vats... 167
Lice on Cattle... 166 Western Office... 165
Lice, To Destroy... 167 Wheat Growing in Ky... 168
Lucern... 168 Wheat in Minn... 166

on the hills after planting, or dusted on the leaves of the young plants. If there is a manure attachment to your drill, it is a good plan to drop the plaster with the seed.

Mangel-wurzel should be sown as early as the land can be got in good condition. We sow in drills about 30 inches apart, with an ordinary grain drill. The land should be rich, and then 300 lbs. of good superphosphate mixed with coal-ashes and drilled in with the seed will be a great help. Sow 4 lbs. of seed per acre. Thin out the plants to 12 or 15 inches apart in the rows. If you sow by hand, soak the seed for 48 hours in rain-water, changing the water every 12 hours. Cover the seed from one to two inches deep. Roll the land before and especially after sowing the seed.

Potatoes as a rule, especially Peachblows, do best when planted early; but we have had a good crop of Flukes planted as late as the first of June. A clover sod on light loam is considered best for potatoes. If the land is dry and rich, it does not matter what the previous crop may have been. Mark the land carefully three feet apart each way, and drop one large potato or two sets in each hill. Cover two or three inches deep with a hoe. A spoonful of plaster dropped in each hill frequently has a beneficial effect. We have known it increase the crop 50 bushels per acre. If planted in drills, drop the sets 15 to 18 inches apart. We make the drills with a light steel plow, 3 feet apart for Early Rose and 3½ feet for Peachblows. Cover with a plow three or four inches deep, and as soon as the weeds begin to start, or before, harrow the land with a Thomas or other light harrow. See Hints for last month.

Beans are sown as soon as we are through planting corn. They are usually sown on a clover sod. Rows 2½ feet apart, and four or five beans in a hill 12 or 15 inches apart, or if drilled in with a grain-drill, drop the beans about two inches apart. Plow the land carefully and harrow very thoroughly, and roll before planting. Use the cultivator freely and keep the crop clean. If you can not do this do not go extensively into bean growing.

Mowing Land should be got ready for the machine. Pick off stones. Put a stake by the side of any stone that can not be removed, so that you will not run the machine against it.

Sow Plaster on clover and on dry upland meadows—say one to two bushels per acre.

Pastures are frequently injured by turning stock on to them before the grass has got a good start. Keep the stock on grass land intended for corn, potatoes, or beans until the regular pastures afford a good bite.

Young Clover, when the dew is on, is very apt to produce hoven in cattle when first turned out to pasture. The green, wet clover ferments in the stomach.

Milch-Cows will be longing for green grass before it is ready for them. We do not believe in the notion that if they once taste grass they will not eat hay afterwards. It is not true. Cut up hay, moisten it with water, sprinkle on a quart of corn-meal and a quart of bran to each bushel of the hay, and let the cows have all they will eat, night and morning. Continue this feed after the cows are turned out to pasture as long as they will eat any of it. It will pay.

Calves should be fed liberally. Nothing, of course, is so good as new milk; next fresh skimmed milk, with flaxseed tea or oil-cake tea. A little nice early-mown hay, bran, oatmeal, corn-meal, oil-cake, sliced mangels, carrots, or parsnips are all good for calves in addition to a run in a sunny, sheltered pasture.

Sheep.—Let ewes and lambs have the best of pasture, and give a daily feed of clover hay and sliced mangels if you have them. Dock and castrate the lambs when three or four weeks old. Tag the old sheep, and keep a sharp lookout for any symptoms of foot-rot. If any are affected, pare and dress the feet of the whole flock immediately with crude carbolic acid or a saturated solution of blue vitriol.

Do the work thoroughly, and repeat in three or four days.

Swine should have rings in their noses and be turned out to pasture every day. Clover is best for them, but they will do very well on grass. Young, growing pigs should have some grain in addition to the grass. Pork is likely to be high next winter, and it will pay to feed liberally.

Work in the Horticultural Departments.

In all sections wherein gardening is carried on May will bring plenty of work. There will be the planting of the general crops, besides the numerous odd jobs of which every garden has its share. There will also be an abundance of weeds to contend with, which will give constant employment. Aim to always keep in advance of the work. If the weeds are once allowed to become established the labors of the coming season will be more than doubled. Keep the cultivators, hoes, and rakes moving rapidly. This will be all the more necessary should a long season of drouth ensue. Then, watering is impracticable, and all that can be done is to stir the soil as often as possible. Keep a record of the daily operations. It will take but a few minutes each day, and will be of much value for reference in the future. Put down the date the different crops are planted, kind of manure applied, and any other items of interest.

Orchard and Nursery.

Root-Grafts should be got out at once, setting them in rows four feet apart, and the grafts twelve inches in the rows, taking care to press the earth firmly around the lower part of them.

Planting of all fruit trees must be completed as rapidly as possible. If properly heeled-in, they can be set out a week or two after those in the nursery have started. If crops are to be raised between the rows, supply plenty of manure so that the trees will not be robbed of nutriment. In planting, have the trees set out in straight rows. Nothing looks more slipshod than trees planted irregularly.

Trees received from the nursery should be buried root and branch for a few days if their bark is shrivelled; this will usually restore them. If the buds have started from too much heat and moisture, cut back severely before planting.

Mulch.—If orchardists would mulch their newly-planted trees as soon as set out, there would be less complaint that nurserymen send out poor stock. The mulch prevents the soil over the roots from drying, and insures a vigorous growth.

Insects.—It is not yet too late to look after the eggs of the tent-caterpillar. It will require less time to destroy them now than when they are hatched. Wild-cherry trees serve as breeding places for caterpillars, and if any are allowed to remain they too should be kept clear of them.

Seedlings should all be set out this month and the rows kept clear of weeds. Seeds should be sown at once in fine soil. Collect seeds of Maples, Elms, etc., as soon as ripe, and sow at once. Evergreen seeds require to be sheltered with lattice-work or brush; otherwise the sun will kill the young plants as soon as they get above ground.

Grafting should be finished this month if not completed last. It is best to set the grafts just before the leaves start, but where there are a great many to be set this can not always be done.

Fruit Garden.

Planting.—The directions given above will serve in this department as well.

Packages.—Where fruit is marketed, provide a supply of crates and baskets, and see that they are in order for immediate use and properly marked.

Cuttings of currants and gooseberries buried last fall may be set out, and after one season's growth will be fine young plants. Press the earth firmly around the cuttings.

Grape-Vines.—Be careful not to injure the buds

when working among the vines. Allow only one cane to grow on newly-planted vines the first year; select the strongest, and remove the others.

Currants.—If borers have worked in the bushes, cut out all the injured portions and burn; their work will be shown by the yellow, sickly appearance of the bush. Dust the leaves with powdered white hellebore if the currant-worm appears. Mulch both the old and newly-planted bushes.

Strawberries must be set out as soon as the ground will allow. Use only strong plants from runners. Keep the beds, both old and new, clean and well mulched, to prevent weeds from growing, and to keep the berries from being soiled with earth. Cut off all runners unless plants are wanted.

Raspberries and Blackberries should have been set out last month, but if not attended to then do it as early as possible. Tie up the last year's growth to stakes or trellises, and apply a heavy mulch.

Kitchen Garden.

Such of the hardier vegetables as were sown last month will now be growing, and should be kept free from weeds, and, as soon as large enough, thinned. In most localities, all the varieties of vegetables, except perhaps tomatoes and egg-plants, may be planted in the open ground now.

Asparagus.—Do not cut until the plants are two years old, and if they can be left until three all the better for the future of the bed. Set new beds now.

Beans.—Do not plant until all danger from frost is over; then plant in rows three feet apart. Limas started on sods under glass may be set out when cool nights are over; and when the ground becomes dry and warm seeds may be put in.

Beets.—Thin out the early plantings and keep carefully hoed; the thinnings make greens, preferred by many to spinach. Plant for a succession.

Cabbages, Broccoli, Cauliflower, etc., all need the same general treatment when young. Set out early plants from the hot-bed or frame, and keep well hoed. Sow for late crops in the open ground.

Carrots.—Sow the main crop when the soil is warm, and keep clean from the start, or the weeds will soon exceed the carrots in size, and the crop be injured.

Celery.—Sow seeds, if not already done, in open ground.

Corn.—Plant as soon as all danger of frost is over in drills 3½ to 4 feet apart. Plant every week or ten days for a succession.

Cucumbers.—Plants started on pieces of sod may be set in the open ground and covered at night with frame or even a paper to prevent their becoming chilled. Sow seeds in open ground as soon as warm, and dust the plants when up with plaster or ashes to prevent the "bugs" from working on them.

Egg-Plants.—Do not set out until cool nights are over and the ground becomes thoroughly warmed; then set in rich soil two feet apart each way.

Lettuce.—Keep the soil around early-set plants loose and free from weeds. Set out new beds and sow seed for a later crop.

Melons require the same treatment as cucumbers. When growing well, give liquid manure once or twice a week.

Onions should have been sown last month to insure a good crop. Weed as soon as up and keep the soil stirred often. Ashes worked in between the rows, and worked in with a hoe, and a dressing of salt are beneficial.

Parsley.—Soak the seed in warm water and sow in open ground, patting down the earth well.

Peas.—Bush before they fall over. Earth up a little when hoeing. Plant late sorts in rows four to five inches deep, so that they will not dry out during warm weather.

Potatoes.—Finish planting for general crop, and hoe the early sorts as soon as up. Just before the potatoes appear above ground draw a harrow over the rows; this will destroy numerous weeds.

Radishes.—Sow every week for a succession, and keep clear of weeds.

Parsnips.—The earlier these are sown the better the crop is likely to be. Use only last year's seed. Hoe and weed as soon as the plants appear.

Rhubarb.—Do not gather from plants set last year. Cut off all flower-stalks as soon as they appear.

Squashes for late use should be planted by the middle of the month in rich soil. Treat the early sorts the same as cucumbers.

Tomatoes.—Transplant as soon as warm enough to the open ground, setting the plants 4 feet apart.

Turnips.—Dust air-slaked lime or ashes on the young plants as soon as up to destroy the black fly which attacks them.

Flower Garden and Lawn.

Planting will form the main work in this department for the first part of this month. Evergreens succeed best when planted some time during this month. Great care must be used not to allow the roots to dry by exposure to the winds, as when this happens the tree seldom survives. Set out ornamental trees at once before they commence their growth. If any trees need moving attend to it at once.

Lawns.—Clear up all dead leaves, sticks, etc., if not done before. The lawn should be cut often in order to keep the surface neat and smooth. If the grass is not too thick allow it to remain on the ground; it will serve as a fertilizer, and also prevent the sun from drying out the roots.

Shrubs.—A selection of early flowering shrubs will give a place an attractive appearance in spring before the leaves have started on the ornamental trees. Shrubs flower better if properly pruned.

Edgings around walks and beds should be kept neatly cut, and no grass or weeds allowed to grow on the paths.

Paths.—If any new paths or drives are needed make at once, and use plenty of broken stone as a foundation, and finish with gravel.

Annuals.—Sow as soon as the ground becomes warm—at least by the middle of the month. Keep the beds clear of weeds.

Perennials should be planted in a separate bed from the annuals. Sow seed of those now coming into flower as soon as ripe.

Bulbs.—Set out Gladiolus, Tiger-flower, and Lily bulbs in rich soil. Tuberoses do best if planted in pots and started in the house before setting out.

Climbers.—Sow seeds of Sweet-pea, Cypress-vine, Morning Glory, etc., where a screen is needed and for covering trellises.

Dahlias started in the house may be planted out now, and as soon as they commence their growth they must be tied to stakes.

Greenhouse and Window Plants.

Do not put all the greenhouse plants out of doors, as is sometimes done, but keep the house looking well the year round. This can easily be done if a little pains is taken with shading.

Shelter.—Some shelter is needed for Camellias and other greenhouse evergreens when they are placed out of doors during the summer. The best thing is a sheltered spot surrounded by trees, but not under their drip, and the ground where the pots are to be placed covered with coal ashes to keep out worms. Florists use a lattice-work shed built for the purpose.

Plunging is sometimes resorted to with plants which it is not expedient to turn out of the pot, and also when it is desirable to use greenhouse plants for decorating the lawn. Such plants as Palms, Yuccas, Ficus, and other subtropical things, may be used for this purpose with fine effect.

Bedding Plants.—Do not set out until settled warm weather, and then in good soil, and give water until the plants are well established.

Summer Propagation may be carried on in a cool greenhouse kept shaded during the middle of the day.

Commercial Matters—Market Prices.

The following condensed, comprehensive tables, carefully prepared specially for the American Agriculturist, from our daily record during the year, show at a glance the transactions for the month ending April 13th, 1874, and for the corresponding month last year:

Table 1: TRANSACTIONS AT THE NEW YORK MARKETS. Receipts and Sales for Flour, Wheat, Corn, Rye, Barley, Oats.

Table 2: Comparison with same period at this time last year. Receipts and Sales for Flour, Wheat, Corn, Rye, Barley, Oats.

Table 3: Stock of grain in store at New York. Wheat, Corn, Rye, Barley, Oats, Mill.

Table 4: Exports from New York, Jan. 1 to April 9. Flour, Wheat, Corn, Rye, Barley, Oats, Peas.

CURRENT WHOLESALE PRICES.

Table of current wholesale prices for various commodities including Flour, Wheat, Corn, Rye, Barley, Oats, and other grains and oils.

Gold has been up to 113 3/4 and down to 112—closing April 11th at 113 3/4 as against 112 on March 12th. The receipts and sales of Breadstuffs have been on an extensive scale for the season. The arrivals of Corn have been unusually heavy. The demand for Flour, Spring Wheat, and Corn has been active, largely for export. Prices have been variable, closing generally with more firmness. The dealings in Oats have been quite liberal, and the market closed strong; prime samples of both Mixed and White, scarce, and wanted for trade purposes. Rye has been in better request, and much firmer toward the close. Barley has been plenty, and seriously depressed in price, with less inquiry for sup-

plies. Spring Wheat and Mixed Corn has been sold to a considerable extent for forward delivery at the ruling figures. There has not been much call for Wheat, millers having been the principal buyers, and purchasing only to meet urgent wants. The rise in ocean freights toward the close tended to check operations on export account. Provisions have been more active, the transactions in Pork, Lard, and Bacon having been largely on speculative account at firmer rates. Beef easier; Butter and Eggs much cheaper; Cheese about steady. There has been a fair movement in Cotton for prompt and forward delivery, closing, however, in favor of buyers. Tobacco, Seeds, Hay, and Straw have been moderately sought after within our revised range. Wool has been in fair demand, and though somewhat irregular during the month closed rather stronger, with very scant supplies of really desirable grades available. From California the reports are that shearing is now quite general, and that the San Francisco market will be quite liberally supplied in the course of a few weeks. A lot of 48 bales new Spring Clip has been sold in San Francisco at 25c., gold. The Wool was from Santa Cruz Island, light condition with few burs. According to recent advices, fully a fourth part of the sheep in Northern California has been lost, which loss, however, will probably be made up by the increase of the clip in Southern California, so that the quantity of Wool raised in 1874 will doubtless about equal the clip of 1873. Hops have declined materially, on a very dull market. In most other articles trade has been without notable activity.

New York Live-Stock Markets.

Table of New York Live-Stock Markets showing week ending receipts for Bees, Cows, Calves, Sheep, Swine, and Total.

Average per week for Bees, Cows, Calves, Sheep, Swine. Do. do. last month. Do. do. prev's month.

Beef Cattle.—The regularly increasing supply of cattle has to some extent prevented an advance in prices that the good demand might have warranted. At the close of last month an increase of over 1,000 head per week broke the market, which remained dull until the still further increased receipts at the beginning of April reduced prices fully 1/2 c. per lb. Prices are yet too high for liberal consumption, and the market is sustained only by the unexpectedly good demand. Trade has been active during the month since our last report, and as we close we have to note a falling off in the demand and a shrinkage in prices, extra heaves selling at 12 1/2 c. @ 13c. to dress 60 lbs. per cwt.; steers and oxen bringing 10c. @ 12 1/2 c. to dress 56 to 58 lbs.; and rough cattle, dressing 55 lbs., selling at 9 1/2 c. per lb.

The prices for the past four weeks were as follows: Table showing week ending range and average prices for Large Sales.

Milk Cows.—The demand has been steady, with a fair promise of advanced prices; but the heavy receipts of March 29 were too much for the trade to dispose of without a reduction, and prices were marked down \$5.00 per head. At the close the market was tame, with a little better feeling, the range being from \$40 to \$80 for cow and calf. Calves.—The receipts of this stock have been steadily increasing, but the demand has been steady also, and prices remain firm at 8c. @ 10c. per lb. for veals and 11c. @ 14c. per lb. for hog-dressed. Sheep and Lambs.—After a week or two of dullness, the market has fully recovered its tone, and sellers ask full prices, without, however, raising quotations. Buyers can get no reductions, and sales are about equal to supply. Unshorn sheep sold at the close at 7 1/2 c. @ 9 1/2 c. per lb., and spring lambs of poor quality brought \$6.50 @ \$8.00 per head. Swine.—The market for live hogs has been practically dead; there have been no offerings for many days, and those offered early in April were not good. Thin Ohio hogs averaging 121 lbs. brought 5c. per lb., and good hogs would bring 6c. Dressed hogs have been easy throughout, and the quotations as we close are 7 1/2 c. @ 7 3/4 c. per lb., with 7 1/2 c. as the ruling price.

As to Breeding Sows.—"D. L. G." Honey Creek, Mo. Although it is stated by some writers upon "the pig" that if a sow is not brought to the boar when her pigs are two or three days old she will not breed again until the pigs are weaned, that is not always the case. On the contrary, sows are sometimes brought to breed when their pigs are four weeks old, as in your case, but more frequently they are not. If the sow is allowed plenty of exercise, and is well fed, she will less often fail to breed than when kept up in a pen. No directions can be given for spaying sows. The operation must be learned by practice only.

DO YOU WANT ONE OF THE VALUABLE PREMIUMS? TWO MONTHS MORE.

May and June are the two months remaining, during which any person who wishes to obtain one or more of the useful and valuable articles offered in our Premium List (of which a copy will be sent free to any applicant, see page 199) can easily get them. This has already been done by more than 14,000 persons, who during years past have tried with success the raising of Clubs of Subscribers for our papers, and availed themselves of the liberal offers of Premiums made by the Publishers.

We invite all our Subscribers to take hold of this work and secure a Premium while the offer is open. Specimen copies of both papers will be sent to any wishing to show them for this purpose.



containing a great variety of items, including many good hints and suggestions which we throw into smaller type and condensed form, for want of space elsewhere.

Remitting Money:—Checks on New York City Banks or Bankers are best for large sums; make payable to the order of **Orange Judd Company, Post-Office Money Orders** for \$50 or less, are cheap and safe also. When these are not obtainable, register letters, affixing stamps for postage and registry; put in the money and seal the letter in the presence of the postmaster, and take his receipt for it. Money sent in the above three methods is safe against loss.

Postage: On *American Agriculturist*, 12 cents a year, and on *Hearth and Home*, 20 cents a year, in advance. Double rates if not paid in advance at the office where the papers are received. For subscribers in British America, the postage, as above, must be sent to this office, with the subscription, for prepayment here. Also 20 cents for delivery of *Hearth and Home* and 12 cents for delivery of *American Agriculturist* in New York City.

Bound Copies of Volume Thirty-two are now ready. Price, \$2, at our office; or \$2.50 each, if sent by mail. Any of the last seventeen volumes (16 to 32) will also be forwarded at same price. Sets of numbers sent to our office will be neatly bound in our regular style, at 75 cents per vol. (50 cents extra, if returned by mail.) Missing numbers supplied at 12 cents each.

Clubs can at any time be increased by remitting for each addition the price paid by the original members; or a small club may be increased to a larger one; thus, a person having sent 10 subscribers and \$12 may afterward send 10 more subscribers with only \$8; making a club of 20 at \$1 each; and so of the other club rates.

The German Agriculturist is published at the same price as the English edition, and is mainly a reproduction of that paper, with a special department edited by the Hon. F. Münch. Will our readers kindly mention this to their German friends? Perhaps some who employ Germans as gardeners, laborers, etc., would be glad to supply them with useful reading matter by subscribing for the German edition for them.

Gardening for Profit.—New and enlarged edition. The success of Mr. Henderson's work has been something unparalleled in the history of rural literature. No work of its class has in this country, and probably not in any other, had anything like the sale this has met with. The reasons for this are that it met a want which no other book did, and the author told all the secrets of the business without any reservation. The publishers intended to bring out a new edition next fall, but the demand during the past few months has been such as to make it necessary to produce it at once.

Several new chapters have been added, and, in the selection of varieties, much has been changed, though the plan of the work is the same as before. The new edition, now in press, will probably be ready by the time this reaches our readers, or a few days after. Though over thirty pages larger the price will remain the same, \$1.50 by mail.

Our Western Office.—Our friends in the West are reminded that we have an office at No. 4 Lakeside Building, Chicago, Ill., in charge of Mr. W. H. Busbey. Subscriptions to *American Agriculturist* and *HEARTH AND HOME* are taken there, and sample copies of the papers and chromos are delivered, and orders received for advertising on the same terms as in New York. All our books are on sale at the Western Office. Please call and examine, buy, subscribe, and advertise.

Prize Essays on Lawn Management.—The makers of the "Philadelphia Lawn Mower" offer prizes for the best essays on the management of lawns. There are nine prizes, amounting in all to \$368. The competing essays must be received at the office of the makers, 631 Market street, Philadelphia, before the first of June.

Black Ash Shingles.—"A Constant Reader," West Shelby, N. Y. We know of nothing that will prevent black ash shingles from warping; it is their nature to warp. If we had no choice but to use this timber we would work it up into what are called "shakes," strips two feet long, eight inches wide, and three quarters of an inch thick at the butt, and use them.

Cabbage for "Crout."—"H. C. C.," Adams Co., O. Any hard-headed cabbage is used for making sauer-kraut. The Flat Dutch and Bergen Drum-head are used about New York, but any one adapted to your soil will answer.

Bugs on Grape-Vine.—E. O. Wetteyer. The insects that eat off the blossoms of your grape are no doubt rose-bugs. The only remedy is to shake off early in the morning, catch in a dish with water, and kill.

The Michigan Bee Association will convene at Kalamazoo, May 6th, 1874. Arnd C. Balch is President.

The Horticultural Exhibition of Lyons, France, is now one of the most important held in Europe; a note from the Secretary of the Cerele Horticole informs us that the next annual exhibition will be held in September next, 17th to 20th.

Buried Pork.—"C. W. N.," Essex Co., Mass., in digging a cellar, discovered a fat hog which he had buried four years before, and found it in a state of almost perfect preservation. He asks why it did not decay. Fat buried in this manner decays very slowly indeed, and there was probably enough to protect the other parts of the animal. Oily seeds, when buried deeply in the soil, are preserved for a very long time. It often happens that fat, and even flesh, when buried, is converted into a peculiar substance called adipocere, and in this state bodies are found after very many years, with their form almost perfectly preserved.

Size of an Acre.—"J. D.," Brooklyn, N. Y. A piece of land 210 feet on one side and 207 feet 5 inches on the other, will make an acre. If an exact square is desired the side will be 208 feet 8 inches and $\frac{6}{10}$ of an inch. Upon newly broken prairie sod a crop of 20 bushels of wheat is a fair yield; with every favorable circumstance this yield may reach 25 to 35 bushels per acre. Even more than this has been occasionally raised.

Sending Plants by Mail.—"A. C. S.," Factoryville, Pa., writes—"I sent some strawberry, raspberry, and other plants to my son in Washington Territory by mail, packed in the following manner. I took common quart oyster cans, cut out one end to make room for packing, moistened the plants, filled the cans, putting some damp moss on top. Cut a piece of tin the right shape to cover the end of the can, and soldered it tight. Put paper around the whole for convenience in directing. Although they were nearly four weeks on the way, yet they arrived in good order, and nearly all lived."—This will answer in cold weather with dormant plants, but had the weather been warm, or the plants in a growing state, they would have been decayed and useless.

Newburgh Bay Horticultural Society.—This wide-awake society announces its annual exhibition for September 22d to 24th. Aside from the

great shows at Boston and Philadelphia such a fine display of fruit can not be seen elsewhere.

SUNDRY HUMBUGS.—In fulfilling our duty in looking over the mass of humbug material, one is reminded of a certain resemblance these affairs have to plants. We hope the plants will excuse us for mentioning them in such company, but it is only in the matter of duration that humbugs resemble them. Some plants perform their career in a day, others take weeks and months. Again, some endure for a year and two years, while many continue from year to year indefinitely. The humbugs are many of them too lovely to last, and have almost the evanescence of the mushroom. Of this kind is the Magnolia (Iowa) "Library Concert," run by the promising Maynard. We mentioned last month its removal to Chicago, but before the article reached our readers the "moral" youth was stopped; the hard-hearted officers, who had no "music in their souls," arrested Mr. Library-Concert-man, and thus this affair went out almost as rapidly as a puff-ball under a hot sun. Of the annual kind the majority of the quack medicines are good examples, as the average duration of these is not more than a year. Now and then one of these turns out a perennial, but they rarely flourish after the first winter. The most lasting humbugs are those which are on the border line between rascality and respectability. The Kentucky Public Library Lottery is an example in which a scheme is kept along by the aid of names that have heretofore been considered respectable. This is a perennial, the existence of which depends upon the season. So long as there are showers of greenbacks every few months this disgraceful affair will survive, but when people become tired of throwing away money upon it there will be an end.

THE CRIES OF THE WOUNDED

after a battle is one of the saddest things about war, and it is really the sober side of our humbug matters. However vexed we may feel that a person should be so stupid as to trust his money to swindlers, whose promises every sensible person must know can never be made good, yet after all we read the letters of the victims with sadness. There is often a touch of the pathetic in the complaints of those who could ill afford to lose; but there is hope for them, as they generally request us to publish their cases as warning to others. The victims of the Union Furnishing Co., of Chicago, have not yet ceased to cry out. All the consolation we can give them is that Geo. B. Hodge & Co. are closed, and that they have thousands of companions in suffering. These letters are sad, but one from a man in Vermont is

A HORSE OF ANOTHER COLOR.

This gentleman likes the *Agriculturist* because it exposes humbugs, but he is on the lookout for a "gift enterprise" that is reliable. He sends us a circular of one which claims to have done business for ten years, and says, "If I could see any one who ever drew anything of any account, or a large sum of money and got it, I might have some faith." Faith in a gift enterprise! Here is a confiding gentleman. Why, bless your dear Green Mountain heart, the object of these men is to get money, not to give it. There are many things in which one may have "faith." To take no higher view, you may have faith that honest work will bring honest money, that a dollar earned will do you in the end more good than a hundred dollars cheated out of other people, as it would be if you drew it in a lottery—but "faith" in a "gift enterprise" never!... Here we have it:

"DOCTOR MARTELLUS IMPROVED MAGNUM OPUS."

What Dr. M.'s "big work" was before he improved, we don't know, but now it is a "chemical preparation for making all explosive fluids non-explosive." What mischief this will play with the nitro-glycerine business. And then "this preparation not only saves lamps from exploding, but prevents chimneys from cracking and breaking." It will not mend a cellar door and put a baby to sleep yet, but when this "magnum opus" gets "improved" a few more times we can't say what it may do. Such things as these are hawked about the country by plausible, glib-tongued fellows, who can convince nine people out of ten that the claims are true, and apparently prove it by experiment.

Gumption is not an elegant word, but it is the only single one that we know of that expresses in short "an intelligent and practical knowledge of matters and things in general." If *gumption* could be imparted at schools, if a majority of people had it, these multitudinous humbugs would have "no show." Alas! the lack of *gumption*. Once in a while these vendors meet the wrong customer. The chap with the "magnum opus" happened at Tiffin, Ohio, to meet with a man with *gumption*—but we will let him tell his own story: "This evening a young man called at my house selling a compound (see the inclosed circular). After putting some of his preparation into the lamp, he lighted the wick and stuck it in the lamp, but coal-oil of the proper standard will admit

of that. When he came to test the chimney, he dipped it in cold water, then put it on the lighted lamp, and as soon as he could be commenced throwing cold water on it without its breaking. I asked him to let the chimney get thoroughly heated, and then apply the cold water. The result was a broken chimney. Before he commenced his experiments I asked him what was your opinion and also that of Munn & Co. His answer was it was something new. He acknowledged before he left that he gave up all hopes of selling any to me after my asking the opinion of the agricultural and scientific papers."

If any live where they can not get this "magnm opns," we can tell them that a little *silicic oxide* or *calcic carbonate*, which the unlearned call sand and chalk, if put into a lamp, exactly 23 grains of each, will prevent all danger to the lamp—provided the right kind of oil is used. It may be well to say here that even very dangerous oil will extinguish a lighted match—oil does not explode; it is the vapor from the poor oil mixed with air that explodes.

DOUBTFUL CASES.

We have already stated that we keep many cases under advisement awaiting investigation, and when the suspected parties are at distant points this often takes a long time. Among the concerns that we have had inquiries about are several that look suspicious; but we can not give definite answers. If the writer of either of these inquiries should go to a merchant to buy goods upon credit, he would be asked at once for his references. Every man who has money should put himself in the position of the merchant who has goods to dispose of, and before he lets his money go out of his hands into those of an unknown person, demand references, or some assurance that he is to be trusted. The gentleman who inquires about the "Mississippi Valley Manufacturing Co." should not send money until he first finds out if there is such a company; which he can do by writing to the mayor or city clerk of the place..... If there is such a concern as the "Empire City Paper Co.," it does its business in a room far up-stairs, with a hole in the door for letters. We hope our Tennessee friend will get his paper..... The "Five Dollar Sewing Machine" chaps are—as the market reporters say—much inquired after. We have yet to see a \$5-machine worth the money, and we have tried very hard. At one time we had a curious collection of these rattle-traps. We have just now but one, that sent out by A. Cateley, Supt., corner Greenwich and Cortlandt streets. If any one wishes to buy this for something less than \$5, we are open to an offer "on account of whom it may concern." We are asked if this Cateley is the same Cateley & Co. who offer cheap watches in another part of the city.

OFFERS OF COUNTERFEIT MONEY

still continue. We say offers, for these people are not fools enough to have or part with any. If they get a poor weak fellow into their hands, they will get his money and give him nothing in return—well knowing that one who enters into a bargain with them dare not "sneal." It is of no use to publish the names under which their circulars are sent, as each one of the gang has a dozen aliases, and they are changed so often that it can help nothing. The postal law checked the flood of circulars for a while, but the chaps send them to be mailed at small places where there are no detectives. The business presents no novel features.

MEDICAL HUMBUGS.

Almost every month there is some interesting novelty in this class of humbugs, but the spring styles do not open very attractively..... A young man asks our opinion of "Diftenbangh's Remedy."—We do not give an opinion of secret remedies of any kind. If he wishes advice, we will say—let them alone..... Here comes J. W. Van Namee, M.D., all along with a lavender-colored pamphlet about "Psychometric and Clairvoyant Powers to Locate and Diagnose Disease." There! if that isn't "pooty tasted," we don't know. The whole subject is too much for us, and we turn to something more tangible. "The Good Samaritan," published by E. Andrews, Albany, N. Y. The great trouble about many of these incarnations of evil is that we can not tell just how bad they are without polluting our pages. Here is this Andrews, who blasphemously uses the name of Jesus, and on the next leaf proposes to do that which we can not mention. The pamphlet *irly* reeks with foulness, deceit, and humbuggery. The wretch claims to have healed diseases "at the Holy Sepulchre, at the Well of Siloam" and numerous other sacred spots upon one page, and upon the next offers to tell how to catch fish without bait or net. He claims to have lived in Albany for over a quarter of a century, which shows what a city in the present day may tolerate and not meet with the fate that befell Sodom and Gomorrah.

THE "NATIONAL SURGICAL INSTITUTE."

A gentleman writes from Indianapolis that he highly

approves of our course in showing up "humbugs," but thinks we ought not to include the above named concern, as he believes that it is doing "a great deal of charitable work, pecuniarily and professionally." If the persons managing this "institute" had not claimed in their circular to be regularly educated physicians, we perhaps should not have noticed it. We judge the "institute" solely by the manifestoes it sends out. Let us ask our correspondent what he would think if he received a circular like this: "The National Church, served by first-class, regularly ordained Ministers, open every day to attend to the cases of sinners. The most hardened that have been to other churches, and not converted, are advised to try here. We have several remarkable sermons on hand, of a kind not preached in any other church." Following this an enumeration of particular sins; then a lot of portraits—A B before attending, A B while being preached to, and A B after conversion. Besides this, the pattern of the clergyman's gown, three or four styles of baptismal fonts, and an exact representation of the communion service. Imagine a whole broadside covered with engravings of this kind to match an equal space on the other, covered by the most ridiculous claims for the peculiar efficacy of this church over all others. Would not our Indianapolis friend be simply disgusted with a circular of this kind? Would he not feel not only that the claims were absurd, but that the pictures were of things that should not be presented to the public eye? Would he not say, "If this church is not a humbug, and its ministers quacks, why do they act in a manner to make people think they are?" That is all we have to say about this institute. If the persons connected with it are educated men, why do they act like quacks? If properly educated physicians, as they claim to be, how horribly must they feel when they see the circular, which is absolutely repulsive with its human deformities and snfering and is in form and manner like the advertisements of quacks and impostors.

Butter-working Machinery.—"J. A.," New York. The "Dake" process of working butter is as well adapted to the purposes of country stores, where butter of all kinds is received, as any we know of, and perhaps better. Such butter of various colors and qualities is not salable in the market except at a low price, but if well mixed and brought to a uniform color it is more readily salable, and fills the demand for a low grade by the poorer class of consumers. This is accomplished by this process. The address of the party is D. W. Dake, Beloit, Wis.

Patent Phosphate.—"T. M. H.," Hunterdon Co., N. J. There can be no patent upon a so-called superphosphate made by mixing 600 lbs. bone-dust with 200 lbs. oil of vitriol, and seven bushels of earth with some salt, gypsum, and nitrate of soda. It is wanting in novelty, as such mixtures have been made for years back by hundreds of people.

Milk Fever in Cows.—This disease is to be feared amongst cows over four years old that are well bred and good milkers, and that receive more than ordinary care and attention. The system in a vigorous condition, filled with rich blood, and not having the elasticity of that of a younger and growing animal, is suddenly subjected after calving to a reflux of the blood which has been circulating through the system of the calf. The drain upon the mother's system consequent upon the support of the calf's life is stopped, and a great reaction occurs. The parts of the body which have been excited during the birth of the calf suffer from the reaction, and the womb and udder and frequently the bowels become inflamed. Sudden changes of the weather also increase the difficulty, and after a fit of shivering, which may occur from the first to the third day, a fever sets in, the appetite fails, rumination is stopped, weakness across the loins causes a staggering gait or an inability to rise, the udder is hard, hot, and swollen, the animal groans, looks wild, and frequently falls into convulsions, or becomes frantic and dashes her head about violently. When these last symptoms occur, rapidly following the first, recovery is very doubtful. To prevent an attack of this disorder, the cow's feed should be reduced some time before calving, and only hay and bran gruel be given to her. The bowels should be kept loose by a few handfuls of linseed meal, and plenty of salt should be given. If the cow is in good flesh she should have one pound of Epsom salts with half an ounce of ginger a week before her time is up, and as soon as she shows signs of calving in the relaxation or looseness of the hinder parts, she should be kept in a quiet and well-sheltered part of the stable; a loose box or stall being the safest place, in which she need not be tied up. If there is a flow of milk it should be drawn from the udder. If the cow has had this fever previously, or her symptoms cause an attack to be expected, she should be given twenty-five drops of tincture of aconite three or four

hours after calving, repeating the dose every six hours until four doses have been given. If, in spite of all precautions, an attack occurs, the aconite, as previously mentioned, should be given along with two drams of powdered opium in a bottle of thin gruel immediately. A pound of Epsom salts with half a pound of common salt dissolved in water, with some sugar or molasses to flavor it, should be given soon after. Cloths dipped in hot water should be placed across the loins, and the cow should be covered with blankets. All the cold water she will drink should be given as frequently as may be needed, and she should be kept as quiet as possible. The milk should be drawn every few hours. Pure, fresh air is also indispensable.

Seven-Months' Calf.—"Subscriber," Westchester, N. Y. It is not impossible for a cow to produce a perfect calf in seven months. Cases occasionally occur the authenticity of which is undoubted.

Eggs all the Year Round.—"W. H. H.," Jersey City, N. J. It can not be expected that a hen should lay continually. The productive capacity of a hen is enormous when she lays moderately well. If she lays 120 eggs a year she produces fifteen pounds, or thrice her own weight. Some time for rest is therefore necessary. But if hens are allowed to set and produce a brood of chickens, their time is not only profitably employed, but by skillfully arranging the time of setting, some may be brought into laying while others are "laying off." Some hens may be set early in the summer and they will lay in the fall, and some may be set later and they will lay during the winter if fed generously and kept warm.

Cross-bred Fowls.—"W. H. H.," Jersey City, N. J., writes as follows: "A neighbor of mine crossed a Black Spanish hen with a White Leghorn cock. Some of the chicks were black and some white, but the most of them were a mottled gray color, which have made very fine fowls, and have proved themselves remarkably good egg-producers. The pullets commenced laying December 26th, and by March 1st the flock of twenty-five had laid 586 eggs.

As to Bots.—"D. J.," Ontario. Bots are the larvae of the horse gad-fly (*Cestrus equus*), and are in a condition exactly equivalent to that of the caterpillar of a moth or butterfly. They therefore can not breed or reproduce themselves in the stomach of a horse, being imperfect insects and incapable of breeding. It is easier to prevent their presence in the horse's stomach than to get rid of them. If the yellow nits or eggs which may be seen upon horses' knees or shoulders in July or August are washed off with warm water, or scraped off with the edge of a knife, the horse can not lick them off and carry them to their temporary resting-place. Every farmer should learn the natural history of the insects and animals with which he comes in contact; then he would know how to treat them with propriety.

To Kill Lice.—"D. J.," Thornhill, Ont. Whale-oil is fatal to lice and not hurtful to cattle. An ointment of three parts of lard and one of sulphur liberally applied is also destructive to lice.

Wheat Growing in Minnesota.—The St. Paul and Pacific Railroad Company have instituted a novel method of disposing of their lands in Minnesota. They sell 640 acres to one or four (not more) persons at \$6 per acre without any payments until the third crop has been harvested. The terms of sale are that the purchaser shall fence the whole of the purchased tract, break up the surface, excepting that part which may be too wet for tillage, plant forty acres in timber, and cultivate the rest in crops each year. The cost of the improvements by contract is as follows: breaking, \$3.50 per acre; sowing with wheat and seed, \$2.87½; harvesting, \$3 per acre; thrashing and hauling to depot, 14½ cents per bushel. The average yield of wheat is 20 bushels per acre, and the price from 70 cents upwards. Persons with a capital of \$5,000 are now engaged in raising wheat in Minnesota upon lands purchased on this plan, with every prospect of raising the purchase money out of the land before the time of payment shall arrive.

Spent Hops as Manure.—"W. B. C.," Sandusky City, Ohio. Spent hops are a very valuable fertilizer and are worth drawing 5 miles. They may be used as an absorbent in the stable or be composted with the manure, or piled up until rotten, being frequently turned to prevent dry rot, and then baled to the field and spread and harrowed into the soil. As a general rule manure should not be plowed under unless the land is to be soon cross-plowed, in which case the manure is brought near the surface again; and this is the best place for it.

Artificial Manures upon Poor Land.—"R. H. S.," Fayette Co., Pa. It would not pay to buy guano or superphosphate to apply to a corn crop without there was something in the soil to aid the effect of those fertilizers. They start the crop and it looks promising, but if the soil is not able to carry it out to maturity they can not do it alone, and the crop falls off and fails to pay their cost. This is beginning at the wrong end. The first thing to be done is to save the manure you are now wasting as you say by exposure to rain. It would certainly not pay to borrow money to buy guano in this case at \$110 per ton; but it might pay to buy some extra feed for your stock and improve the quality of the manure, and to make improvements in your stables and yards to prevent its waste.

Experiments with Waste from Wool-scouring Vats.—"G. P. L.," Philadelphia, favors us with the following experience with the waste from vats in which wool had been scoured. He pumped the water into a tight wagon box, holding 10 barrels, and hauled it on to the fields, where it was spread. A timothy meadow, to which it was applied, yielded 3 tons of hay per acre, and very good fall pasture. The crop of corn was increased by it one fifth, in yield of grain and largely in fodder. Potatoes failed partially; mangels failed entirely, and Hungarian grass, sown upon the same ground as a substitute, also failed. The waste contained the loss of 20,000, in shrinkage of 50 per cent on 40,000 lbs. of wool, which consisted of yolk and sand mainly; 5 casks of soda ash, 10 barrels of urine, and 5 barrels of cotton seed oil soap. (We should like to know upon what extent of land this was spread.)

Agricultural Plaster.—"J. V. V.," Salado, Texas. The sulphate of lime used for manure, is not calcined, but is simply the rock, crushed and ground fine. It is worth about \$7 a ton in New York.

Bones.—"E. R. S.," Greenbrier Co., W. Va. The best method of reducing bones for use in a garden is to place them in barrels in layers along with unleached wood-ashes and keep them moist for several weeks, when they may be readily pounded fine enough for use.

Plaster for Market Gardens.—"M. J.," Cherry Grove, Pa. We have no reason to believe that plaster would be of great service upon market gardens. It is a special manure valuable upon clover, peas, corn, and other broad-leaved crops grown in the field, but it is not sufficiently stimulating for the purposes of the market gardener; certainly not if used alone, but if used along with others it might be worth while trying with cabbages, potatoes, or corn. When sprinkled upon young cabbage plants, beans, melons, or turnips, it is often of use to drive off the flea or the squash bug.

Ashes for Top-Dressing Wheat.—"R. W. T.," Wicomico Co., Md. Wood-ashes may be applied to wheat as a top-dressing at any time. They will not injure either bones or superphosphate that may have been applied at the sowing of the wheat.

Shallow Plowing for Corn.—"R. H. S.," Dnnbar, Pa. It was once said by an intelligent farmer that the soil should not be plowed deeper than it could be manured. There is much truth in that idea. Upon that principle it would not be well to plow a sod for corn so deep that the sod is buried beyond the reach of the roots of the corn. The depth of the plowing depends altogether upon the character of the soil, and what may be right for one soil may not be so for another.

Peas.—"L. W. F.," Chambersburg, Pa. There are two varieties of peas known as Canada peas, one the Black Eye Marrow Fat and the other the Gray pea. The first is suitable to a rich soil, upon which it makes an extraordinary growth of fodder. The second is a pea with a less developed vine and smaller seed, but it will yield a crop where the first would be unprofitable. Any produce dealer or seedsman in New York could supply the seed. It arrives in this market in barrels, and is now quoted at \$1.25 per bushel.

Poland China Hogs.—"L. G. C.," Hawcahon, Ill., writes that he has sold his last July Poland China pigs in February of this year, and they weighed from 225 to 240 pounds. The spring pigs of the same breed were sold in the fall, and averaged 300 pounds each.

The Slide Gate.—"J. A., Jr.," Morrow Co., Ohio. The simple plan of sliding a gate upon a roller or a bar placed between two posts has been in use for many years. But there have been many patents taken out for peculiar rollers to be adapted to the sliding gate. We have frequently cautioned our readers

against giving notes to swindlers who claimed patent rights which do not belong to them, etc. If any device has been in use two years before a patent covering it was procured that patent can not be sustained, and if any person claims a patent right upon a gate, simply sliding upon a bar or an ordinary roller, which has been procured within 20 years past, he claims more than he can sustain at law. When one of these patent claimants comes along do not be frightened or let him bully you into paying anything. Ask to see his patent. If he can not show it, get the name in which it was issued and precise date of issue and tell him to call again. If he is an impostor he will bluster and will not be heard of again. If he is a real owner of a patent that you have unintentionally infringed, he will behave like a gentleman and give every opportunity for you to find out if his claim is a just one. For a small fee a copy of the patent can be had from the patent office. Recollect that the farmers have some rights that even owners of patents are bound to respect, and that the law was not made to oppress honest and innocent people.

Curdy Milk.—"A. A. B." When a cow's milk curdles while sweet and her yield suddenly falls off three fourths, it is evident that her health is seriously affected, but how or why, it is impossible to say without knowing something more than this bare fact.

Catarrh in Sheep.—"R. S.," Wayne Co., Michigan. Sheep if kept too warm in the winter will take cold and run at the nose. There is danger that this may affect their lungs and cause fatal disease in the spring. The remedy is to keep them during nights in an open shed with a yard attached to it, so that they may have the choice of in-doors or out-doors as they desire. They will generally choose the outside of the shed. A tea-spoonful of pine tar placed upon their tongues and one upon their noses will be some help. During the day they should have, at least, some hours' exercise, in a field or in a large yard in which there is no manure.

Pure Light Brahmas.—"A. L.," York, Pa. The description of a pure Light Brahma, according to Tegetmeier, is as follows: Head white, neck white with black stripes down the center of the feather, breast, belly, and thighs white, back and shoulders white, saddle white striped with black, wings white with a black stripe on the edge, formed by the black feathers known as "primaries," tail black, legs bright yellow, feathered with white feathers slightly mottled with black.

To Destroy Lice.—"J. H. F.," Colony, Mo. There is no really effective method of destroying lice upon any animal without oil or grease of some sort. In some recent experiments in England a mixture of one part of sulphur with three parts of lard and a mixture of one part of oil of tar with three parts of linseed oil destroyed the lice to which they were applied almost immediately, while corrosive sublimate, mercurial ointment, arsenious acid and carbolic acid were without any effect at the end of two hours, and tobacco water destroyed the vermin at the end of an hour. We have found a mixture of lard and kerosene oil to completely destroy lice both upon poultry and calves without any injury to the animals whatever. Kerosene oil alone will severely injure the skin.

Feed for Pigs.—"H. D.," Madison Co., Iowa. There are no roots so valuable for feeding to hogs, cooked, as potatoes. The prolific coarser varieties as the Harison, Peerless, or Garnet Chili would be the best to plant. The best green crops for summer feed are clover, peas and oats mixed, vetches or cabbages. Rye would answer for early spring feed. Hogs might, no doubt, be profitably pastured within hurdles, as is commonly done with sheep.

Care of the Poultry Yard.—"S. P. T.," Susquehanna Co., Pa. We have not sufficient room here to give full directions for managing a poultry-yard with all sorts of fowls and under all circumstances. Few books even can do all that, but "Wright's Poultry Book" will be found to contain as much as any other book we know upon these matters. Price \$2.00.

Food for Sheep and Lambs.—"E. P.," Otsego Co., N. Y. Roots should always be provided for sheep, yet they must not be fed in excessive quantities during the winter, as they then become indigestible and dangerous from the large amount of water they contain, which reduces the temperature of the stomach, and in the case of ewes in lamb have often caused death. For 100 sheep two bushels of roots, sliced and sprinkled with bran, may be given at a feed. Hay or straw should always be fed between the feeds of roots. The best roots are sugar beets and ruta-bagas. Mangels

are considered less valuable than these. Young lambs may be fed a small quantity of bran and ground oats, scattered thinly in a broad flat trough so that one can not get more than its share.

Impregnation of Turkeys' Eggs.—"T. Burr Marsh," Tewkesbury, Mass., states that in the spring of 1870 he purchased a flock of hens and with them a hen turkey which laid 15 eggs, and then wanted to set. The eggs were placed under hens; the turkey was broken up, and soon commenced to lay again. The second laying of eggs upon being set under hens proved fertile although there was no turkey cock in the neighborhood. Several other correspondents have related similar experiences, which shows that one impregnation fertilizes the eggs of a second brood of a turkey hen.

Nests for Early Chickens.—"J.," West Vincent, Pa., says that hens' nests for early hatching at this time of the year should be lined with clay. They are thus made warmer, being air-tight, and are cleaner than if of any other material.

Beans for Feed.—"Inquirer," Clinton, Co., N. Y. Old or discolored and unmarketable beans may be ground and fed to stock, either cows, hogs or poultry, with profit. But unless ground they are not readily eaten. For hogs or poultry the meal should be cooked and fed in thick mush, cold; for cows the meal should be stirred in hot water and given as a drink when nearly cold, or may be mixed with cut hay.

Sheep in the Orchard.—"B. S. H.," The obviously best cure for a sheep that barks apple-trees is to keep it out of the orchard. It is their nature to do this whenever they have an opportunity.

Duration of Scab.—"G. W. C.," Potter Hill, N. Y. It requires at least two years before the pasture or the yards which have been occupied by scabby sheep will become safe for the occupation of a healthy flock. Those places where the sheep have rubbed themselves have become infested with the insect which causes the scab, and in bad cases the ground itself may be in the same condition by means of dropped locks of wool; so that even careful whitewashing of the yards and fences may fail to make the place secure.

Slow Killing of Meat.—Philip Mick. The length of time occupied in killing an animal has no ill effect upon the meat; on the contrary, it is said to make it tender. For this reason, as well as to make the flesh white, butchers used to bleed calves to death so slowly that they were often twelve hours in dying, and the same practice was in use with turkeys until the cruelty was stopped by law. It is more likely that the diarrhoea complained of was due to some unhealthy condition of the animal, possibly from its possessing some parasite in its flesh, as "measles," which always produces this effect.

A Poultry House for Young Chicks.—"J.," West Vincent, Pa., describes a house in which he successfully raised a large number of early chickens last year as follows: It was ten feet long by eight wide, made of hoards except the front, which was glazed. There were four corner posts, a floor in it, and it was kept warm by a stove. The sash for the glass was made of laths, and the whole cost of the material was a few dollars. In fine weather the chicks were allowed to run out in a small yard exposed to the sun. In this house there was room for two hundred chicks. By giving good care to the chicks they may be taken from the hen very early, and the hen put to laying again.

Cure for Balking.—"W. P.," Port Chester, N. Y. There is no specific cure for a balky horse. Gentle treatment and extreme patience have often effected a cure of this vice. Violence and punishment only make matters worse.

Millet for Soiling.—"H. K. G.," Rockland Co., N. Y. Millet makes a very good soiling crop. We do not know that it is any better than fodder corn or so good, but it has the advantage of making a variety which is very agreeable and desirable for cattle, whose appetite it is necessary to stimulate in this way. The seed is very small and should be lightly harrowed in upon mellow soil. This crop succeeds better upon well-drained rich soils. If the soil is moist we would rather choose oats and peas mixed for a fodder crop.

Removing Turnip Flavor from Milk.—"Mrs. C. C. E.," Randolph, Wis., sends us the very old information that a pinch of saltpeter dissolved in the milk will remove the flavor derived from feeding turnips. As this may be new to some of our more recent

readers we repeat the fact, as well as the equally useful one, that if the turnips are fed immediately after the milking the next milking will be free from any disagreeable flavor.

Horse Talk.—"Clip," Natick, Mass. We would not breed from a spavined mare; the deformity, or weakness which causes spavin, is often constitutional and hereditary. The Turf, Field and Farm, published in New York, is a weekly journal devoted to the "horse interest" chiefly.

Sorghum.—"New Beginner," Ogechee, Ga. Sorghum, or as it is sometimes called, China sugar cane, is planted and cultivated the same as corn. About two quarts of seed per acre is used. The hills are generally planted four feet apart in check rows. The yield of syrup is from 100 to 300 gallons per acre, but so far the manufacture of sugar from the syrup has not been a success, on account of the difficulty of crystallizing it.

The Northern Spy in New Jersey. I. J. Blackwell, of Titusville (N. J.) Nurseries, writes: "This is justly considered one of the finest apples to be found in our markets. In size, color, and quality it is all that can be desired. It seems to be a fair but not heavy bearer here; and unfortunately in this section it ripens in September, and will not keep through October. The Tompkins Co. King is a September fruit, and the Rhode Island Greening ripens early in October, and will not keep through November. Many of the fine Northern apples lose their late-keeping qualities here. The Fameuse or Snow apple ripened this year in August."

An Egg within an Egg.—"R. C.," Philadelphia. Such cases occur now and then. We have seen several, and they are frequently reported.

Wheat Growing in Kentucky.—"O. B.," Bogle Co., Ky. The practice of growing two crops of wheat in succession, then clover for hay, followed by clover for pasture, and again commencing with wheat, will soon wear out the richest land. On your best limestone soils you might by feeding the clover and spreading the manure thus made, and then pasturing and plowing under a good sod, raise one crop of wheat every third year, but we doubt if you can raise two crops in succession for many years.

Corundum.—Will the gentleman who several months ago sent us specimens of Corundum kindly inform us what locality they are from?

Renting a Small Farm.—"J. O. B.," Pa. It is better as a general rule to rent a farm either for a money rent or for half the grain than to hire it worked, when the owner can not supervise it himself. Upon 27 acres it will hardly pay to keep a pair of horses and hire a man steadily. There is not sufficient work to keep them from "eating their heads off," unless it is a market garden, and then there would be more than they could do. An ordinary farm of that size might make a living for one man, but it is too small to make any profit for an owner who has to hire labor.

Bois d'Arc.—A Louisville (Ky.) paper publishes a long article on the wonderful qualities of the Bois d'Arc tree of Texas, and it is now going the rounds. If the article had only stated that what is called Bois d'Arc and Bodock in Texas is elsewhere known as Osage Orange it would have been more sensible.

Forcing Rhubarb.—"J. B.," Chicago. It would be a waste of money to put up a house for forcing rhubarb in winter. A hot-bed will answer every purpose. As the tenderest stalks are produced in the dark, a pit containing a plenty of fermenting manure covered with boards will give as good results as a more expensive arrangement.

Report of Swine-Breeders' Convention.—"J. J. D.," Sabina, Ohio. For this report apply to Col. F. D. Curtis, Charlton, Saratoga Co., N. Y.

Remedy for Potato Blight and Rot.—"D. C.," Berkley, Mass. We know nothing about this save what is given in the circular. The statement that insects are the cause of the potato disease is absurd, even if supported by the statements of members of Congress. We do not use or advise the use of or advertise any manures unless we know their composition.

For South Carolina.—"R. A.," Laurens Co., S. C. Merino sheep are more suitable for South Carolina than Cotswold. The latter thrive better in a colder climate. Essex pigs would probably suit your

climate best, Berkshire next, and the Poland-China would not be suitable. In size, these pigs rank in the order in which they are mentioned, the first being the smallest. The muzzle shown in the *Agriculturist* of October, 1872, is the best preventive of ribbing we know of. Morgan horses are generally dark bay or brown. Orchard grass would probably be the most suitable grass for South Carolina. It needs a rich, dry soil.

Hennery Wanted.—"C. C. M.," Greenwich, Ct. We do not know where there is a hennery on a large scale carried on expressly for the production of poultry and eggs for market. If any of our readers know of such a one we should be glad to learn of it, for our own sakes as well as for the information of our correspondent.

Plant Trouble.—"Western Subscriber," Ill. is troubled by flies which deposit eggs in the earth of flower-pots; these hatch into small white maggots, which injure the roots. Try watering with perfectly clear lime-water. We have tried this in some cases for earth-worms without injury to the plants. Whether it can be used for all plants we can not say.

Cancer in the Eye.—"S. W. L.," Oskaloosa. We know of no cure for cancer in a cow's eye except removal of the eye, which could only be done by a surgeon.

Cabbages for Seed.—C. N. Brown. Cabbages from which seed is to be raised must have the stump preserved quite as carefully as the head. Some set them in trenches deep enough to hold the whole cabbage, and when they are a little frozen cover them plentifully with litter to keep them at a uniform low temperature. Others open a furrow, and set in the cabbages inclined one upon another in the direction of the furrow, and carefully cover the stumps with earth. When freezing weather comes on, earth is drawn up to cover the heads sufficiently to prevent freezing and thawing.

Corn in Egypt.—G. W. Caunnack, Ashley, Ill., which is down in Egypt, sends us some figures of his corn crops to work up. He says he shelled 20 ears and the corn weighed 13½ lbs. He plants four feet apart each way, with two stalks to a hill. He gets from one to six ears to the hill, and the corn weighs 66 lbs. to the measured bushel. From these figures we get the following: At 4x4 feet there are 2,722 hills to the acre; allowing three ears to the hill as an average there would be 8,166 ears. If 20 ears weigh 13½ lbs. there would be 5,406 lbs. of shelled corn, at 56 lbs. to the bushel, equal to 98 bushels per acre.

A Cultivating Harrow.—"W. E. M.," Clay Co., Minn. As the object of cultivating is to loosen and mellow the soil, as well as to destroy weeds, the use of a roller immediately after a cultivator or harrow would neutralize both these effects, and would therefore be inadvisable.

Shrinkage of Corn.—"D. W. H.," Utica, Mo. It depends somewhat upon the kind of corn how much shrinkage there will be in drying. A variety with a large cob would shrink more than a smaller variety. Southern or Western Dent corn will shrink 25 per cent in drying, and flint corn about 18 to 20 per cent.

Three-Horse Clevis.—"F. C. Wright." The clevis of which you send a drawing and description is patented. Persons making and using it are therefore liable to the owners of the patent right for infringement.

Lucerna (Alfalfa).—"J. K.," Wilmington, O. When a good plant has already a good name by which it is widely known, it only leads to a confusion of ideas to give it a new and incorrect name. The plant now frequently called "alfalfa" (its Chilian name) is lucerna, and is widely cultivated in Europe as a green forage plant. It would doubtless succeed very well in Southern Ohio, but needs a deep rich soil for its profitable culture. It will stand several cuttings in a year, and last several years. The advertisement of the Rev. J. Copeland which you send to us is a genuine affair, and no humbug.

Moles.—"M. A. S.," Warrenton, Va. We have not been very successful in getting rid of moles. The latest remedy we have seen is to make a dough of meal mixed with arsenic; make a hole in the run, and drop in a pill as large as a marble; then cover the hole to exclude light. This, if followed up, is said to destroy them—but we have not tried it.

Easter Flowers.—It is estimated that the floral decorations in the New York City churches on

Easter Sunday cost a total of upwards of thirty thousand dollars! A small portion of these only are purchased by the funds of the churches, the greater part being voluntary gifts by wealthy attendants.

Mole or Drain Plow.—"G. E. S.," Union Co., Pa. R. H. Allen & Co., Water st., New York, make a plow that loosens the subsoil at a depth of 14 to 18 inches, which they call the Miner subsoil plow. The use of this plow, which can be drawn by two horses, will probably be as satisfactory in drying the surface soil as the more costly and heavier mole plows.

Hitching Horses.—"H. B. A." It is not safe to hitch a horse to a weight. We would not hitch a colt in that manner. The heavier the weight the nearer the approximation to safety, until the weight is so heavy that the horse could not move it. The flatter the weight the better it would be, and 50 lbs. would probably be safe under ordinary circumstances. A firm post as high as the horse's head is the safest thing to hitch to.

Bee-Stings.—"W. A. B.," Bridgeport, Ct., writes: "The best thing I have ever tried for bee stings is to first pull out the sting, and then take a small tube, the end of a hollow key for instance, and firmly press round the sting for a short time. The reasons for its action, I think, are two: first it presses out the poison, second it bruises the flesh so as to partly stop its spreading. It must be done very quick to do any good. I have tried it, and a good many other remedies, and this has done the best."

Stable Floors.—"H. B. M.," Providence, R. I. A plan of laying a stable floor which is water-proof, solid, and permanent, is described in the *Agriculturist* of November, 1873, page 415.

Pure Butter for 3 cts. a Pound.—"J. K." If farmers, who should know all about butter, can be induced to believe that it can be made in any other manner than from cream, or by the use of powders or any other mixture, and to pay \$1 for the secret, they richly deserve to be swindled, because they become, by trying to make butter in such a way, nothing better than swindlers themselves.

Lice upon Chickens.—"Mrs. S. A. P.," Alpine City. Chickens are everywhere subject to these parasites, which when numerous are frequently fatal to the chicks. The remedy is to grind up some sulphur and lard very fine, and rub the ointment upon the chicks' heads and beneath their wings. Severe heat in a dry climate is a cause of many troubles to young chickens. In such circumstances they should be provided with shade, plenty of water, and green food, such as lettuce, chopped cabbage, etc.

Butter from Suet.—"S. D. J.," Wilmington, Del. It would be useless to give the process for making suet into a substance resembling butter, because it is subject to a patent, and therefore could not be used without paying for the patent right. Whether the process is worth paying for or not is a question we can not answer.

Preserving Meat in Summer.—The refrigerator has come to be indispensable to the comfort of the household. Soft butter, sour milk or cream, tainted meat, and dry, shrunken bread are no longer tolerated in any family whose means enable them to procure a refrigerator. In these, as in other things, there are some requisites necessary for perfection. That perishable articles may be kept from spoiling during hot weather, the cooled atmosphere in which they are kept should be dry. Moisture rapidly produces taint and decomposition, and it is because of the abundant moisture in ice-houses that meat or butter so soon spoils in them, and that vegetables become moldy. Mold is generated with rapidity only in moist atmosphere. In dry air the mold plant can not grow, neither can flesh, fruit, or vegetables spoil. For these reasons the refrigerator should be so arranged that the inside air, while it is cooled by the ice, should not be in contact with it. A refrigerator upon this principle is made by A. M. Lesly, of New York, and is known as the "Zero." The ice is in an upper chest, from which water, as the ice melts, passes through a charcoal filter, and is collected in a reservoir, from which it is drawn by a tap in the front. Upon one side of the ice chamber is a deep chest for milk or bottles of liquid. Below is a close chamber, which has no communication with the ice above; consequently the air in it is dry. What moisture it may have contained is deposited upon the cold walls of the ice-box, from which it trickles through a pipe in which is an air-trap, and is discharged into a pan placed underneath.

Apples in Sawdust.—A "Subscriber" writes that he found sound apples last October in a box in which they had been packed in dry sawdust the fall before. Sawdust is no doubt a good material in which to pack fruit, provided it is from wood that has no unpleasant odor.

Sheep Tick.—"M." Melery, Iowa. The reddish insect which infests sheep is the sheep-tick. There is no better method at this season when dipping is out of the question than to go over the sheep and kill the ticks with a pair of small scissors, crushing the eggs that are found like little brown balls, at the same time, between the points of the scissors. We have gone over 100 sheep a day in this way, and few ticks have escaped. They will be found mostly about the sides and brisket.

Horse and Cow Stables.—"J. A. E.," Baltimore. In the *Agriculturist* of December, 1872, there was a plan of stable for horses and cows in a basement building, which may probably be what you want.

Raising Pork in California.—"H. A. W.," Hay Fork Valley, California. With pork at ten cents a pound it ought to pay well to raise hogs. If clover can not be grown in California, at least alfalfa (lucerne) can be, and that makes an excellent green feed for hogs. Potatoes, oats, barley, and rye all make good feed, and wheat if boiled with potatoes would also answer excellently.

The Jersey in the Dairy.—"E. K.," Whitewater, Wis., sends the following statement of the production of butter by a Jersey cow during last season. The cow had just dropped her third calf, and was four years old, and during the month of May was injured in one teat by another cow stepping upon it. The yield was as follows: March, 40 lbs. 10 oz.; April, 41 lbs. 10 oz.; May, 31 lbs. 10 oz.; June, 39 lbs.; July, 33 lbs.; August, 31 lbs. 4 oz.; September, 35 lbs.; October, 26 lbs.; November, 20 lbs.; December, 17 lbs. 4 oz. The total production for the ten months was 315½ lbs., or over one pound per day on the average. During the last two months 24 native cows, two of which were fresh, and all of the others had come in since the Jersey, made on an average 12½ lbs. per month, and the Jersey made under exactly the same treatment 18½ lbs. per month. He thinks this a fair test of the dairy value of the Jersey.

Concrete Pipe.—"M. O. B.," Nunda, N. Y. There must be some mistake in procuring the proper kind of cement or the pipe could not have failed. There are hundreds of miles of cement pipe laid in the country; several miles of it have been laid by the superintendent of the Onondaga (N. Y.) salt works with entire success. We have also had no trouble in laying cement both for a cistern and pipe.

Underdraining.—"C. W. H.," has a farm of 172 acres, one mile from Columbus, Ohio, that he wishes to drain. It slopes to the east with a smooth surface; has a fall of 10 feet in 1,100 feet. Soil, on two thirds of the farm, clay, the other third black. He asks what is the best material to use. He can get pipe tiles, 3½-inch bore, at 35 cents per rod; flat stone, 75 cents per perch; burr-oak lumber suitable for draining, \$20 per M. Can get second-class sewer pipe, two feet long and six-inch bore, at \$1 per rod. We would very earnestly advise him to use tiles. Taking everything into consideration—ease of laying, durability, and efficiency—they are far cheaper than anything else. For the sub-drains 3½-inch tiles are not needed; two-inch pipes are large enough. A very common mistake is to lay the main drains with two small tiles, and the sub-drains with tiles needlessly large. For a main drain the six-inch sewer pipes would be excellent, and would carry off an immense body of water.

Remedy for the Curculio.—"M. M. Ostrand." There is no plan or device for protecting fruit from the curculio worth anything except the plan of jarring the trees and catching and destroying the insects. All methods by hanging such things as corn-cobs soaked in syrup or in carbolic acid even in the trees are as ineffectual as trying to catch old birds with chaff.

Cross-bred Pigs.—"C. W. H.," Columbus, Ohio, writes: "I have crossed a thorough-bred Essex on Poland-China sows. The pigs are very fine."—We should expect a very useful class of pigs from such a cross. One or two more crosses with Essex may be used with advantage.

The Star Thistle.—"Senex" writes: "Dear Mr. *Agriculturist*; I wish to follow up your remark about *Centaurea Americana* as a well-known cul-

tivated plant. Being older than you are, I can remember a long way back. About forty years ago we used to have this showy annual in our country gardens. Nuttall introduced it into cultivation from Arkansas. Barton figured it at Philadelphia in 1822, and Don in England in 1831, since which I suppose seeds have always been in the market and the plant in many gardens. Lately, Thompson, of Ipswich, England, raised a particularly good variety of it from E. Hall's seeds, gathered in Texas, and this has given the species a new start."

After Ruta-bagas.—"C. A. K.," Arlington, Mass., writes that he has raised three hundred bushels of ruta-bagas upon half an acre. The best crop that can follow these roots is rye or wheat, with grass and clover. The best rotation when roots are raised is corn, oats, followed by turnips the same season, or ruta-bagas or mangels the next season, and finally wheat or rye, with grass. But several hundred bushels of roots can not be taken off from an acre of ground without exhausting the soil; and the reason that your crops have failed after the ruta-bagas is probably for want of the needed fertilizer. Two hundred and fifty pounds of fine bone-dust or of superphosphate, with a few loads of manure, might have told a different tale.

Coughing and Wheezing Hogs.—"L. C." It is not often that hogs suffer from cold. They more frequently suffer from too much warmth and insufficient ventilation. Then a sudden change of temperature affects the lungs or bronchial tubes, and coughing and difficulty of breathing result. When so affected, rubbing the throat and chest with turpentine has been found beneficial, but generally a change of food from grain or meal to boiled potatoes or turnips, with the removal of the cause of the trouble, will remove the complaint.

China Geese.—"J. H. S.," Logan, Ind. The only distinguishing characteristic of the Chinese gander is its shrill voice, which is so marked as to be readily noticed. The marks of these birds are alike in both sexes.

Reclaiming a Swamp.—"Inquirer." There is a process known in agriculture as "paring and burning," which might in some cases be usefully employed in reclaiming swamp lands after they have been drained. Draining is the first thing absolutely essential. Then with a sharp broad-sharred plow turn a broad furrow three inches thick, thus cutting all the roots of bushes, weeds, and tussocks. The sods remain until dry, when they are cut with a broad axe into lengths, and are piled into heaps and burned. The ashes are scattered over the bare surface, which is then sown to grass. Timothy and red-top would be suitable for such a soil. The seed may be harrowed in with a sharp light harrow. This is costly, but where meadow land is worth \$100 an acre it pays. We have succeeded in this way, without burning the sods however, using them with lime for compost for uplands, and lining the drained and cleared swamp with 50 bushels of lime per acre. Timothy grew four feet high upon the new soil.

Use of Swamp Muck.—"I. H. P.," Lexington, Ohio. Swamp muck is of considerable value, when free from sand, as an absorbent in the stable and a help to the manure pile. But it should be dug some months, frozen, and well dried before it is used.

Butter from Sweet Cream.—"A. B. L.," Greene Co., N. Y. There is no method of making butter from sweet or any other cream but by churning in the usual manner.

A Rough-coated Horse.—"A. B. L.," Leeds, N. Y. A rough, staring coat upon a horse is a symptom of ill-health. A change of food is often sufficient to restore the smoothness of the coat. Boiled oats or scalded bran, with a few handfuls of linseed-meal mixed in, and fed cold, may be given along with some mild alterative or tonic medicine, such as half an ounce of sulphur or one dram of copperas daily in the food.

Muzzle for Crib-Biter.—"B.," Perryville, Ill. The muzzle referred to in *Agriculturist* of October, 1872, is not made by any one person in particular. Any blacksmith or wire-worker could make one in half an hour. Very stout wire or light band-iron should be used, riveted where the pieces cross each other.

The Japan Pea.—In reference to this pea, which was described in the Feb. No., 1874, Mr. J. Niel Stribling, Anderson Co., S. C., writes:—I raise the Japan pea as a field crop; the yield is much larger than that of any other pea. I cut the stalks for forage and grain, just before they are entirely ripe, in order to get

the best feed, and thrash in a thrasher. The finer part I take for hay—my cows are very fond of it. To save seed, the top of the plant is taken as it ripens first, and it must be stored in an airy place immediately after cutting, else the sun will pop open the pods. Cultivation, soil, &c., are the same as for cotton. Its maturity is the same as that of the cotton plant. It is a good table pea if soaked twelve hours in salt water before cooking."

Treatment of Lampas.—"J. L. G.," Sappington, Mo. The swelling of the bars of the month is sometimes caused in young horses by the cutting of the teeth, in which case scolding the swollen parts lightly with a sharp knife will cure it, or, what is better still, touching them with lunar caustic. In old horses it occurs from overfeeding with corn or other grain, when a change of food and cooling medicine should be given.

The Ecrase.—"B. G. L.," Lakeville, Mass. The above-named instrument for castrating colts without loss of blood, is made by D. W. Kolbe, Philadelphia, instrument maker to the University of Pa.

Treatment b.—"D. M.," Salem Co., N. J., reports the following successful treatment of scab in his sheep. He si applied kerosene oil with the squirt-can of his thrashing machine to every scabby spot, carefully going over the flock. He also gave each sheep daily, for a week, half an ounce of sulphur in meal. The lambs were treated the same as the sheep. The result was a complete cure in the course of two weeks.

Jersey and Alderney.—"J. W. A." The unfortunate confusion of ideas as to the proper nomenclature of these cattle will probably exist for some years to come, and make it necessary for this oft repeated statement to be re-repeated a hundred times. Alderney was formerly understood as referring to any cattle from the Alderney group of islands, Jersey, Guernsey, Alderney, and Sark. As the cattle are really distinct breeds, and have been very strictly kept so for many years, the name of each island now, and has for some years been given to its own particular breed of cattle. Jersey and Alderney are therefore two distinct breeds. The same trouble is now laying up in regard to Dutch or Holstein cattle, which are Dutch only when they are large, black and white, heavy-milking cattle from Holland, and Holstein when they are red, brown, and other colored beef cattle from Holstein.

Time to use Plaster.—"A Reader," West Shelby, N. Y. Plaster should be used in the spring as soon as the growth is fairly started. As 400 parts of water are required to dissolve one of plaster, and it is very heavy and readily carried in loose soil beneath the reach of the plants, it is only when there are copious rains or dews that it produces its best effects.

Patching Old Roofs.—"C. H. P." It is unsatisfactory business to patch old shingle roofs with roof paint of any kind. Better put on a new roof at once.

Flax.—"T. G. A.," Nemaha Co., Kansas. Flax may be made a very profitable crop upon rich bottom land if proper care is given to it. The soil must be very clean and free from weeds. If grown for seed only a bushel should be sown per acre, as the thinner the crop the more the plant spreads, and the larger and better the crop of seed. A fair yield is twelve to eighteen bushels of seed per acre. It should be sown early, or about the time of sowing oats.

The Peach Prospects.—Knowing the desire of both producers and consumers of peaches to have the earliest reliable intelligence from the great peach center, we have requested a gentleman who has unusual facilities for procuring information to keep us advised of the prospects. The following is the outlook up to the time of our going to press—April 15th:—I am in almost daily communication with prominent fruit raisers in all parts of the great peach-growing districts of Maryland and Delaware. The reports are somewhat conflicting as to Delaware. In the lower part of Kent and Sussex counties the trees have been in full bloom for some days, as they also have in the following counties in Maryland, all large peach-growing districts—Queen Anne's, Caroline, Talbot, Dorchester, Worcester, Somerset and Wicomico. These are the southern counties on the eastern shore; but few peaches raised on the western shore. The prospect in the above named counties, the most southern part of the peach districts, is only fair, as we have had much cold weather, with ice, sleet, and several severe frosts, seriously affecting the crop in the inland orchards. Those orchards located on

or near our bays, rivers, or inlets, are not affected so much by frost and sleet. Notwithstanding all this, the prospect is that there will be an immense crop of fruit shipped from those districts the coming season. In the upper part of Kent and New Castle counties, Del., the upper part of Queen Anne's, Kent, and Cecil counties, Md., the trees are not yet in bloom, and the prospect was never better for an immense crop of peaches. The question now among our people is to know what to do with the fruit if the crop should prove as large as the present prospect would indicate. Already capitalists are on the move, and canning houses and Alden drying establishments are springing up all over the country, and with all these increased facilities, if the present prospect holds good, peaches will be thrown on the market in such quantities this season that the prices will rule low, and nothing but prime fruit be worth shipping. While there may be failures in some localities, the prospect, on the whole, was never better for a great crop. The prospect for small fruit crops is good. Eight years ago we did not ship one car-load of berries a day. In 1873 we shipped on the Delaware railroad as high as sixty-five car-loads of strawberries a day.

Books Noticed.

Our publishing friends must excuse us. In the spring months we are so crowded with purely agricultural matters that we have been unable to acknowledge their favors. We can only give the briefest mention.

FIELD ORNITHOLOGY, Comprising a Manual of Instruction for Procuring, Preparing, and Preserving Birds, and a Check List of North American Birds, by Dr. Elliott Coues, U. S. A., Salera, Naturalists' Agency. This title is so descriptive that little need be added to indicate the contents of the work. It is by one of the best of our practical ornithologists, and written in such a plain and direct style, and withal so full and complete, that it makes just the work needed by both young and old ornithologists. Price \$2.50.

PLEASANT TALK ABOUT FRUITS, FLOWERS, AND FARMING, by Henry Ward Beecher. New York: J. B. Ford & Co. The publishers do well to issue a new edition of these "Talks," most fitly called "pleasant." There are a few additions to the first edition, which we well recollect as one of the most charming books we ever read. Mr. Beecher's writings, speaking horticulturally, are not only perennial, but evergreen, and are just as good in 1874 as they were in 1859. The author has the advantage over many who write about horticulture in possessing the not common qualification of knowing something of his subject. These articles are not only bright and cheery, but practical and sensible—in other words, they are Beechery.

JENNY JUNE'S AMERICAN COOK BOOK, by Mrs. J. C. Croly, N. Y. American News Co. The author of this work is well known in literary circles, and her name would predispose one in its favor. Unfortunately a cook book can not be fairly judged by merely reading it; as with a servant one must try it in the kitchen in many ways before deciding upon its value. The lady who presides over the writer's culinary matters says the book "seems promising," and this confirms our own impression. The general directions are marked by eminent good sense.

FLOWER OBJECT LESSONS, or First Lessons in Botany, a familiar description of a few flowers, from the French of M. E. Le Maout. This is a portion of a work by a well-known French author, translated by Miss A. L. Page, Danvers, Mass. With a good teacher this book may be of use in the lack of a better, but notwithstanding the "testimonials" printed with it we think it a very indifferent work. One of its claims is that "not a technical word is used," which strikes us as of no advantage, as common words are strained out of their meaning and applied to things which have "technical" names and no other. If we wish a child in the garden to bring a rake, we do not call it "a piece of iron to which teeth are fixed at right angles, and furnished with a handle," but make the child learn that the proper name for the thing is rake. Yet this circumlocution would be no more nonsensical than the "powder wands" of this book applied to stamens. The fact is that these bodies are peculiar, and they occur only in flowers, and their proper name is stamens, which is just as easy to learn, being but one word, as "powder wands," two words incorrectly applied, and which the child will very soon have to unlearn; many stamens, as it will soon find out, have nothing "wand"-like about them, and much pollen is not powder. Equally absurd is it to call the pistil "column" and "central organ." We are heartily in favor of making the study of plants plain and attractive to children, as has been done by Dr. Gray and Miss Youmans, and which has been attempted without very great success in this book.

EASY LESSONS IN NATURAL SCIENCE, by R. E. Kremer. Philadelphia: Claxton, Remsen & Haffelfinger. What real use this book can serve we are unable to see. It may help one of those stupidities that an inscrutable Providence sometimes allows to stand in the place of a teacher to cram a child's head with fragmentary, disjointed, and useless answers to equally fragmentary and useless questions. To be repeated without any more knowledge of the subject than a parrot. We could fill a page with the absurdities of this book, but a few examples must suffice. Under "Salt" we find "What is common salt?" *Ans.*—"It is a substance used for seasoning or preserving meats, vegetables, butter, and other articles of diet;" and this is all that the child is taught as to what salt really is. Under "Apple" it is asked, "How many varieties are known?" *Ans.*—"Over two hundred." We can not see that this is an important part of a child's education, but as the book professes to teach science, it should approach accuracy. The fact is that one American book describes over two thousand, and does not include all the varieties known. The "vegetable kingdom" is disposed of in just one page, and how full of wisdom that page is may be seen from this: "What great naturalist prepared the system of Botany which is now in use?" Behold the answer!—"Linnæus of Sweden"!!! Mr. Kremer, we would advise you to cram yourself better before you attempt to teach children matters about which you appear to know absolutely nothing. Your book is Bosh.

THE CARPENTER'S AND BUILDER'S ASSISTANT, by Lucius D. Gould. New York: A. J. Bicknell & Co. This is a very concise treatise upon the principles of carpentry, and includes with others the now popular system of balloon framing. The illustrations are exceedingly neat, and the descriptions though brief are clear, and the work can not fail to be of great use to the carpenter who wishes to work by rule.

Catalogues Received.

Our friends who come so late must be content with a very brief acknowledgment of their catalogues, as we have not space for more.

SEEDS.

J. H. & W. E. CONE, Hartford, Ct., with their catalogue of Wethersfield seeds, give a farmers' almanac.

A. S. JOHNSON, North Chili, Munroe Co., N. Y.—Seed Potatoes a specialty.

W. B. DIMON, JR., Brooklyn, N. Y.—Vegetable and Flower seeds.

MILLER & SIEVERS, San Francisco, Cal.—Californian and Australian Tree and Flower Seeds.

H. W. WILLIAMS & SONS, Batavia, Kane Co., Ill.—Flower and Vegetable seed catalogue and a Potato circular. Also Greenhouse and Bedding Plants.

JORDAN HORTICULTURAL COMPANY, St. Louis, Mo.—General Stock of Seeds, Florists and other Plants, and Horticultural Goods.

NURSERIES.

L. B. CHAPMAN, Portland, Me., and 145 Fulton st., N. Y.—Small Evergreens a specialty.

J. & W. J. JUDEPIND, Edesville, Kent Co., Md.—Amazon Raspberry a specialty.

J. W. MANNING, Reading, Mass.—Fruit and Ornamental.

FRANK FORD, Ravenna, O.—Hoosac Thornless Raspberry a specialty.

THOMAS MEEHAN, Germantown, Pa.—Ornamental Trees and Hedge Plants especially.

JONATHAN A. HOLMES, Polo, Ogle Co., Ill.—Apples and Small Fruits.

CALKINS & BROOKS, Bricksburgh, N. J.—Peach and other fruits.

A. D. PRYAL, Oakland, Cal.—General Nursery and Greenhouse stock.

E. Y. TEAS & Co., Cascade Nursery, Richmond, Ind.—Fruit and Ornamental, with extensive Greenhouse stock. Roses a specialty.

PINNEY & Co., Sturgeon Bay, Wis.—Manual of Evergreen and Forest Trees, accompanied by a Catalogue of the same.

FLORISTS.

B. P. CRITCHELL, Cincinnati, O.—A very full catalogue. THOMAS MEEHAN, Germantown, Pa., has added extensive greenhouses to his nursery, and has a full stock.

A. WHITCOMB, Lawrence, Kansas.—This is a charmingly neat catalogue.

WM. H. PAGE (Wm. B. Hovey, Agent), Norwich, Ct.—Flowers & Vegetable Plants.

W. B. DIMON, JR., Brooklyn, N. Y., sends with his catalogue a fine little chromo.

MARION WELSH, Mt. Vernon, O.—Vegetable Plants and Hardy Shrubs, in addition to a full florists' stock.

GEO. W. PENNEY, Newark, O.—Vegetable Plants also.

A. HANCO & Son, Red Bank, N. J.—Bedding and Rare Plants.

H. P. CLOSSON, Thetford, Vt.—Bedding and Greenhouse Plants and Fruit Trees.

EUROPEAN CATALOGUES.

CH. HUBER & Co., Hyères, France.—Rare Plants, Palms, Cannas, etc.

ALEGATIERE, Lyons, France, offers several new double Pelargoniums and Carnations.

ANTHONY WATERER, Knap Hill Nursery, Woking, Surrey, Eng.—This nursery is celebrated for its Rhododendrons, Hollies, and other select plants, and has supplied the finest collections in this country.

F. K. BELL, Stratford upon Avon, Eng., sends a catalogue of his Imperishable Labels, which, from the locality we presume, he calls "Shakespearean."

J. B. GUILLOT FILS, Lyons, France. A catalogue of roses remarkable for its great number of novelties and standard varieties.

NOTE.—We have several duplicates of the catalogues of Anthony Waterer & Guillot Fils, which may be had upon inclosing a stamp to the editor.

IMPLEMENTS.

A. J. NELLIS & Co., Pittsburg, Pa.—Harpoon Hay-Forks.

E. S. LEE & Co., Rochester, N. Y.—Pruning apparatus.

J. J. THOMAS & Co., Geneva, N. Y.—A catalogue setting forth the merits of the well-known Thomas Harrow.

Bee Notes.

BY M. QUINBY.

SOME OF THE OBJECTIONS TO BEE-KEEPING CONSIDERED.—It is well known how much honey is yielded by certain districts in the state of New York. Taking this as a basis and making proper allowance for waste land and other non-producing portions of the area, it is estimated that in this state alone twenty millions pounds of honey are annually wasted for the want of bees to gather it. At the present time instead of stating any arguments in favor of making an attempt to secure this important item in our resources by extending the knowledge and the practice of bee-keeping, it may be well to consider some of the objections that have been made to the pursuit.

Much has been said in opposition to bee-keeping, and said judiciously if it is not proved a legitimate and profitable business. Several writers in the newspapers are manifesting a good deal of interest from professedly disinterested motives. Early in March a little item appeared in the N. Y. Tribune, pretending to be a fair report of a bee-keepers' convention. I failed to discover wherein it was fairly represented. It seemed to me to be especially designed for the purpose of discouragement, by giving only the dark side. Was there nothing said that might have been some benefit? The name "bee merchants" was given to the members. Not more than two or three of the whole number ever bought and sold bees. One especially, that has secured more honey than any one in the state, never yet sold a bee. What constitutes a merchant but buying and selling? Is it just to represent the convention thus? There is about 100,000 pounds of honey sent to New York city annually. The man referred to has furnished about one fourth of it. Now suppose this man who knows how to manage bees successfully attends the convention and teaches his fellows how to manage until five or ten times the quantity is sent to market. The price it now bears would be lessened, and if he did not get his reward on a broader principle than pecuniary remuneration, I think he had better be silent. Where there is an interest, I hope there will be an impartial investigation.

Prof. C. V. Riley, of Mo., has had much to say against the bee. A private correspondent wishes to know what I "have to say to these charges." With regard to the injury bees do to fruit, it would be about the same in substance as was said last month. Prof. Riley seemed desirous to convince his readers that bees injured fruit without positively asserting it. Such words as "I am convinced" and "there is no doubt of it" may reach far enough to convince many readers that he has seen what he speaks of, when he has not committed himself to a positive expression. His proposition to poison the bees is one so repulsive that I abstain from any comment here. His plan to annihilate them by sowing milk-weed shows that he has not investigated the matter. My views on bees and milk-weed were given to the public over twenty years ago. I would not alter them now further than to say that the more that milk-weed was sown near my bees,

the more prosperous I should expect them to be. I have had opportunities of watching more closely since then where there were acres of milk-weed, and bees by the hundred colonies kept in the vicinity, which prospered as finely as any that could be found. The flowers of the weed have a peculiar shape, as well as an appendage that becomes detached and adheres to the foot of the bee, which becomes hooked to the flower when at work and held fast. But it will be found that not over one bee in a thousand is caught fast.

When we had the old box hive, and it was only part full, a few—a dozen bees or so—might be seen on the bottom board in the morning unable to get on the combs above them, because of this adherence to their feet. But very few of the whole number were disabled thus, as was proved by the quantity of these appendages that was worked off of the feet of those in the cluster overhead, that had ascended. Handfuls mixed with scales of wax might be scraped up, proving to me at least that only a small portion of the bees that work on milk-weed are lost. If it should be established that getting honey from the flowers of milk weed did not kill the bees but was rather a benefit to them, the absurdity of the Prof.'s recommendation to sow the weed is evident.

The injury bees are alleged to do to the flowers of fruit, grain, and grass, may be discussed another time. If the objections against bee-keeping are greater than the inducements to undertake it, of course it is better not to commence till these are removed. We think we have recently discovered means to lessen the danger from the dreaded stings, and if we can abandon fear and approach them with a desire to discover facts we shall progress in a ratio quadruple to anything we have done before.

Kentucky Blue-Grass.

BY THE HON. JOHN H. KLIPPART, COLUMBUS, O.

A paragraph appeared in the March number of the *American Agriculturist* from which one would be led to infer that this grass attained its greatest perfection only in a few counties in Kentucky, and that it required a limestone soil on which to flourish in any locality. The fact is that the limestone formation of the blue-grass region in Kentucky extends over Brown, Butler, Clermont, part of Clinton, part of Greene, all of Hamilton and Montgomery counties in Ohio; but for some reason the blue-grass does not seem to flourish so luxuriantly on the Ohio side of the lower silurian formation as it does on the Kentucky side. But in Union, Madison, Greene, Clarke, Fayette, Pickaway, Ross, Franklin, and Champaign counties, in Ohio, the blue-grass grows as luxuriantly and forms as staple a pasture grass as it does in Bourbon or Woodford counties in Kentucky. In the Ohio counties just enumerated the "drift" ranges from five to 150 feet deep; and in some of the counties this drift rests upon black shale, and in others upon the corniferous and Helderberg or Water-line limestone formations. How much influence the bedded limestone or shales lying beneath 150 feet of drift may or does exert upon the blue-grass growing on the top soil I am not prepared to state.

There is no grass which accommodates itself to any given locality with as much facility as does this same blue-grass—it is almost protean in the variations which it assumes according to climate and soil. We find it in southern and central Ohio growing rankly and luxuriantly on gravelly soils; then we find it equally rank on the bottom lands, and it does very well on stiff clay lands. It is the wayside pasture or June grass of Northern Ohio, but it does not do so well nor grow so luxuriantly there as on the gravel soils in southern Ohio.

A writer over the initials "J. L. C." in an article on Kentucky blue-grass, says: "It is one of our earliest grasses, growing, with an upright round stem, from one to three feet high, with three or four long, rich, bluish green, highly nutritious leaves, with a perennial fibrous root, creeping near the surface." This is prob-

ably correct for northern Ohio, but in central or southern Ohio it differs somewhat. There are three or four leaves on the stem, it is true, from two to four inches long; but I have counted as many as thirty radical leaves belonging to one stalk, each leaf longer than the longest one on the stem. In these radical leaves is where the great merit of the plant lies. It is scarcely worth cultivating as a meadow grass or as a grass from which hay is to be made; the radical leaves are too short to mow, and the stems are unfit for hay, being very tough and wiry, so much so that as a matter of fact it is in some localities better known as wire-grass than by any other term. "J. L. C." warns persons not to grow it with clover, giving as a reason that "they are not fit to cut at the same time." If blue-grass is not sown with clover or oats, or some rapid-growing nurse, it will be many a long day before a "set" can be obtained. If sown by itself, the June or July sun will kill the tender plant down to the very roots—at least this has been my experience; but every time I sowed it with clover—and clover is the best nurse for it—I have succeeded in getting a good set. "J. L. C." says: "From the fact of its roots extending near the surface it is easily affected with drouth." Here in central and southern Ohio it resists drouth better than any grass we have. In Union and Madison counties are blue-grass pastures which have not been disturbed by the plow since the settlement of the country, and these undisturbed pastures are the most luxuriant and richest pastures we have. More than fifty years of constant grazing does not appear to have diminished the yield of pasturage. One field in Union county was plowed up some fifty years ago, and several crops of corn grown on it; then it was allowed to become a blue-grass pasture again, but up to to-day any one can see that it is inferior in its production of pasturage to the adjoining fields which were not disturbed by the plow. This is to me conclusive evidence that it is not any more exhaustive than any of the ordinary meadow or other pasture grasses.

A Pigeon Show.

The engraving upon the first page represents the principal prize birds at the first exhibition of the National Columbarian Society recently held in the city of New York. It may be supposed that pigeons are of very little practical use and are unworthy of the notice of persons whose efforts are turned towards producing something useful. But this would be a mistake if for no other reason than that one class of these birds, the carriers, possess a value for their services alone which in some cases can hardly be computed. In the late siege of Paris by the German armies, the mails were frequently carried by these birds, and letters or information either upon political, mercantile, or social affairs of incalculable value were safely sent by their means over the lines of the besiegers. A trained carrier pigeon might easily be the means of deciding the safety or destruction of an army, and thus change the destiny of a nation. Travellers or business men might send a rapid and inexpensive message from a distance or from their place of business to their home, by a carrier pigeon, which might be carried with them for this purpose in a small basket, and many hours of anxiety and suspense be thus prevented.

Besides as pets and ornamental birds they have their place in many a country house, to say nothing of their special adaptation to the

purposes of the pie. We therefore give this prominent place to these portraits from life of probably the most valuable pigeons in the world; for it must be confessed that the birds sent from England for the purpose of exhibition here, as their best, were greatly surpassed by American birds. No. 4, the pigmy pouter, and No. 3, the bronze-wing, are two of these imported birds. They, however, arrived too late for entry and were not therefore in the competition. No. 2, the Antwerp carrier, is a new variety in this country and has already become very popular. These birds have not heretofore been figured; the specimen shown in the engraving is the property of Mr. P. C. Biegel. No. 1, the bald head tumbler, is owned by Mr. H. A. Brown, who entered the five varieties or colors of these birds, which are now almost extinct in America. He received a prize for each color. No. 6, the black swallow, is the property of Mr. T. S. Gaddess. No. 5, the red barb, owned by H. Colell. No. 8, the black trumpeter, owned by T. S. Gaddess. No. 10, a pouter hen, a magnificent bird which took a prize of \$50 and is valued at \$250, is the property of J. Yeudall, Philadelphia. No. 7 is H. Colell's black fan tail; No. 13 is the black English carrier owned by P. C. Biegel; No. 12 the dark almond tumbler owned by A. Scheld; No. 11, the African owl, owned by J. Yeudall; and No. 9, the yellow priest, owned by Mr. Gaddess.

Ogden Farm Papers.—No. 11.

Much has recently been written about large yields of butter, and an active discussion has been in progress on the subject in various agricultural papers. This discussion has revived what I wrote in the Ogden Farm Papers for August last concerning the dairy of Messrs. I. Boics & Son in Illinois. I have recently received a letter from them, in reply to a request for more information, in which they say:

"In our statement to you last spring we think we stated that we made about 300 lbs. of butter per year per cow. We thought so then, and we think so now. We have no means of knowing exactly how much we do make per cow, as we have never yet been able to give the matter a thorough trial. We are milking this winter 132 cows, 84 of which calved in September and October last, 48 having been milked from 12 to 18 months, it being impossible to get some of them with calf. In October last these 84 new milch cows gave an average of 28 lbs. per cow, or something over 2,350 lbs. total of milk, while on January 9th the same cows gave 26 lbs. per cow. The same cows are giving at present an average of 21 lbs. per cow. You will see that there is a great decrease from January 9th to the present time, a part of which is owing to our having to buy hay, and it is not so good as our own, as we take pains to have our hay cut very early. Every year since we have been in the dairy business our cows have given more milk in the middle of May and June than in the months of March and April. In the months of September and October last it took, September, 24 lbs. of milk to make a pound of butter, and October, 21 lbs. January, 23 lbs., and at present we are making from 23 lbs. Therefore, taking the months of May and June at the same average per cow that they are now giving, you will see that the average can not be far from 300 lbs. per cow. We think we can make 300 lbs. from a cow that comes in September 1st as we can 225 from one

that comes in March 1st—both to be milked until they go dry. We intend to weigh all our milk next year, commencing October 1st, and we are in hopes to prove that we can make as much per cow (and as good butter) in Illinois as can be done in the old dairy regions at the East. Our neighbor, Mr. O. S. Tamner, bought 40 cows in the spring of 1873, commenced delivering milk March 1st, and in one year he delivered us 7,212 lbs. of milk per cow, his cows going farrow however."

In their former letter these gentlemen state that they feed their cows "eight quarts of corn and oat-meal (mixed) per day for every day that they give milk. In winter we give them every day, in addition to the meal, a large load of corn in the shuck, also what nice early cut hay they will consume."

The foregoing is a very explicit and exact statement, and there is no reason to question its accuracy.

Supposing the 84 fresh cows to produce, as is stated, from October 1st to April 1st, 4,550 lbs. of milk, yielding about 198 lbs. of butter, we need not strain the point very far to credit them with 102 lbs. for the other half of the year, when they would be mainly at grass, and would each have eight quarts of rich grain feed per day in addition. Mr. Tamner's 40 cows, being left farrow and fattened for the butcher, produced, according to the statement (at 23 lbs. milk for one pound butter), an average of 313 lbs. of butter within one year.

Such a forcing system of feeding is of course hard on the cows. More than one third of the Boies cows failed to get with calf, and with the Tamner cows there was no effort to get them with calf. This process of butter and beef making is closed to those who raise their own stock, but even these may take a hint (to be followed with judgment) from the mode of feeding described.

And what feeding it is! "What nice early-cut hay they will eat" (and hay so good that when purchased hay is fed the cows fall off materially in their yield); eight quarts of oats and corn-meal per day; and a large load of corn in the husk, which must amount to at least 10 lbs. of shelled corn per day for each cow—considerably over a peck of grain per day! No wonder they give large yields of butter and come out at the end of the year beef fat.

There is, too, much more than a hint for Western farmers, who are now groaning under the oppressive charges for the transportation of their corn to the sea-board markets. Why send it at all, you who can feed it at home? Why not make butter or cheese, and from the refuse of the food, and from the skimmed milk and whey make pork, and so put your gross product into a net form? You will get as much for the dairy products and the pork as you would for the corn from which they are made, and will save the cost of transportation on the greater part of your crop.

You will save something else, too—the enormous amount of valuable manure which your corn now makes here at the East and in England. The day has fortunately gone by when an agricultural writer need hazard anything of his reputation by asserting that in Illinois, as well as in all the rest of the world (old or new), the manure question is henceforth to be the question, and that a universal recognition of the value of manure among Western farmers is of the greatest importance to the permanent interests of the country, which depend so much on Western prosperity.

A friend in Maine, writing to congratulate me on the results of my dairying as set forth in the March number, says: "I observe with surprise the large percentage of abortions in your herd—seven out of thirty—and you make no allusion to it as an unusual occurrence. It would be considered so here, and in fact a single abortion is unusual in all this region. In my own herd, varying from twelve to twenty, there has not been an abortion for many years. Is it common with you and in your vicinity, and to what cause is it attributable? If the cause is not certainly known, what are the speculations on the subject?"

Abortion has been common here, but fortunately it is decreasing, and seems to have left my own herd altogether. The speculations on the subject, so far as they have come to my notice, seem to be of no value whatever, and, after the costly investigations that have been bestowed upon it during the past few years, there has been no theory developed which seems to fit the conditions under which it occurs; neither has any effective preventive been suggested, unless it be the one prescribed by Mr. Sam. J. Sharpless, and published some time ago in these papers, and which is worth repeating.

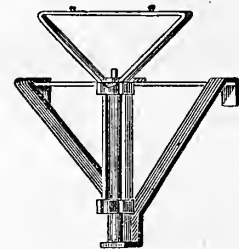

Fig. 1.—SEAT SPRING.

The form of tonic that we have used, and which we think has been effective, is a powder consisting of: 2 oz. sulphate of iron, powdered; 8 oz. ground ginger; 8 oz. fenugreek; 8 oz. caraway; 4 oz. gentian. Dose: A heaping tea-spoonful daily with bran or other feed.

Mr. Sharpless gives this to his whole herd, and during much of the season of pregnancy. We have used it much more sparingly, but with apparent good results. If a cow shows by the swelling of the bearing, by the laxity of the cords at the side of the tail, or by a tendency to spring-bag, that she may be preparing to lose her foetus, we separate her from the herd, give her the powder at once, and give her somewhat stronger food. In every case where we have tried this, for a year past, the indications have disappeared, and the cow has gone regularly on with her pregnancy. The cases have seemed clear enough to show that the powder does good, but it is possible that the epidemic (according to its habit) had run itself out

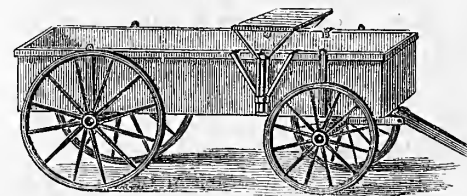

Fig. 2.—SEAT ATTACHED TO BOX.

and disappeared of its own accord—as mysteriously as it came.

There is abundant indication of the fact that a change is coming over the minds of dairy farmers on the subject of Jersey cattle. In spite of hard times, farmers are making active inquiries about them, and actual sales are in-

creasing every year in numbers and in price. A few years ago bull calves could be bought in plenty for \$25 each at six months old, and for not much more at twice that age. The price now runs for good animals at from \$50 to \$100. I am not now speaking of the demand from breeders of thorough-breds, who pay even as high as \$300 for young bulls of unmistakable pedigree and quality, but of that from dairy farmers. I have recently sent two bulls into New York State, one for \$75 and the other for \$100 (express charges being in each case about \$30), both sold to dairy farmers in districts where Jersey cows are almost unknown, and where they are to be used only on native cattle and for the improvement of the herds of butter-producing farms. For another, which I advertised at \$50, I had seven applications within two weeks. Three years ago I should not have had probably a single one. The meaning of this is that butter-makers are awakening to the knowledge that the superiority of the Jersey breed for the butter dairy is an established fact—not a mere fancy of rich men running after a fashion. It has been sufficiently demonstrated that an infusion of Jersey blood into a herd of native cows will materially increase their product of butter, and will make it easier of manufacture and better in quality. This it does without increasing the size of the cows, and without, therefore, causing a greater consumption of food. Such being the fact, it is not at all to be wondered at that intelligent dairymen who are awake to their true interests should be quick to find it out and be anxious to take advantage of the proffered benefit. The good that is to be done to the country by the dissemination of Jersey bulls to be used for the improvement of common cows is of far more consequence than is that of the extension of the use of pure Jersey cows, for the reason that this latter will, at least for a long time to come, be confined to a comparatively few of the better farmers, while one bull in a neighborhood will make a lasting amelioration of all the well kept herds for miles around. This is an improvement, too, which is sure to extend and increase the more the sterling qualities of this race become known, and it must lead eventually to the wide extension of the pure Jersey cow, which stands in relation to the half-breed as gold does to silver.

An Easy Wagon-Seat.

It is somewhat difficult to adapt a convenient spring-seat to an ordinary wagon with the appliances generally at a farmer's hand. We have, however, recently been shown a spring-seat which seems to combine all the requisites of convenience, portability, ease, and cheapness, which would make it desirable for a farmer to possess it. It is shown in the annexed engraving. Fig. 1 shows the spring to which the seat is attached. The spring, a strong spiral steel one, is contained in a strong but light wrought iron frame. The frame is provided with two hooks, by which it rests upon the edge of the wagon-box—outside of it and out of the way of a load—and is so made that it may be slid along with ease from one part of the box to another. The seat is bolted to the upper part, in which there are two holes made for this purpose. Fig. 2 shows the seat complete, affixed to a wagon-box. This seat is patented, and is made by B. F. Wells of No. 47 Dey street, New York.

The Wild Ass.

Although we rarely find an ass engaged in farm labor, yet indirectly this much maligned animal is of agricultural interest and value. As the sire of the mule he renders an invaluable service, and anything new pertaining to his history is worthy of record. By reason of many sorrows and misfortunes and much ill-usage the ordinary ass has lost much of its original spirit and beauty, and it is difficult to recognize in the graceful animal depicted in the annexed engraving (for which and that of the Poitou Mare we are indebted to the London Field) a creature which we might designate as a pure-bred donkey, a true descendant of the original race. The engraving is a portrait taken from a photograph of a young wild ass, a female, which was recently captured after a chase of forty miles, which was made in 3 hours and 5 minutes, upon the Runn of Kuteh by an English army officer and a party of fifty native hunters. The district in which it was captured is a vast grassy plain, much resembling our own Western plains, in Tartary, and is the native home of the wild ass. These animals are very shy and fleet, and being possessed of great endurance are rarely captured. This is the second instance only of a capture, the first being that of a mare heavy with foal, which was taken after having been wounded, and this, being a young animal only six months old, was only taken after having been disabled by a wound from a spear. A remount of horses also was necessary to make the capture. This proves the native endurance of the race and tends to explain also the fact that our domestic ass so well survives the greatest ill-usage, the most severe labor, the poorest and most scanty fare, that his longevity and freedom from disease have become proverbial. It is a fact worthy of notice that the wild ass (*Equus onager*) is colored differently from its domesticated relative. The animal here shown is white and fawn; the under parts of the body, the neck, chest, and nose, part of the face, the rump, channel, and inside of the legs are white; the mane is short, thick, and dark brown. A dark dun streak of long hair runs along the back, widening towards the rear, and continues down the tail to the end. The rest of the body is of a fawn color; the coat is smooth and glossy, and the tail has a tuft of long dark-brown hair at the end. The legs are clean and flat, the sinews prominent, the feet are small, hard, and well formed, and the pasterns long. The ears are smaller than those of

the tame ass, and are constantly pricked, and the eye is of unusual brightness and quite black. The muzzle is small and black, with large open nostrils. This animal does not have the cross upon the shoulders, which is borne by the domestic ass, and is 12 hands high, although



A WILD TARTARIAN ASS.

now only a year old. As this wild ass is probably the original of our domestic one, it is a curious problem to trace out the causes which have led to the variation between it and the races that have descended from it.

The Poitou Mare and Mule Foal.

We have previously described and illustrated the Poitou Mule, and now complete its history

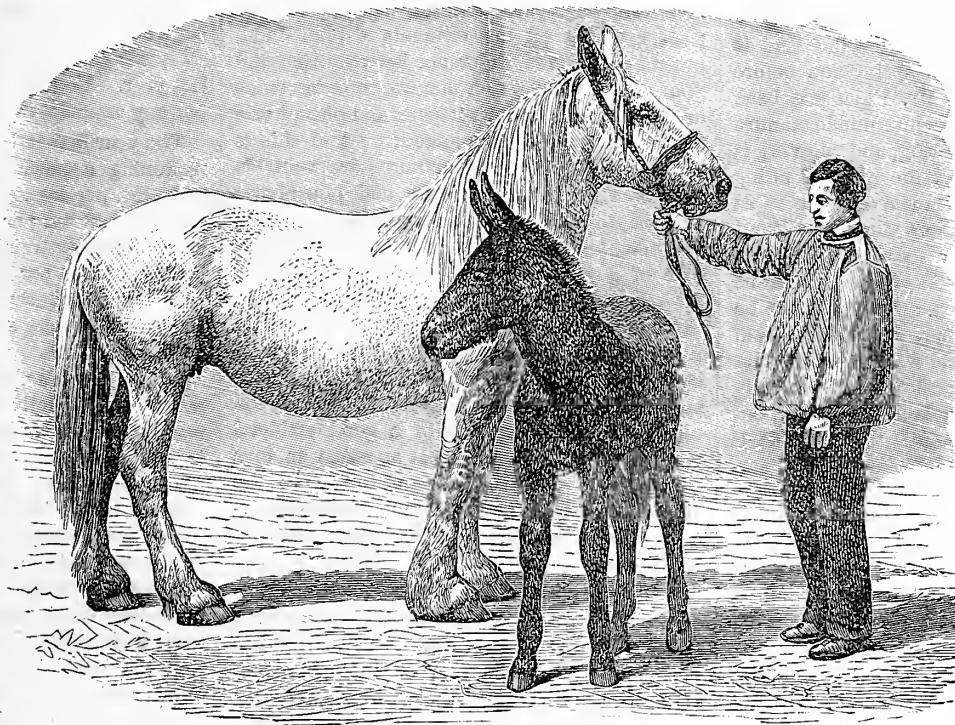

A POITOU MARE AND MULE FOAL.

by describing the typical dam from which it is bred. Indeed this part of its history is of considerable importance in a national sense. As a large number of these animals are annually imported into this country, it becomes a mat-

ter of interest to know if we can not just as well raise the animals we need ourselves, as pay the foreign breeders for doing us this service, and so have this industry added to those we already possess. As in a family everything made at home, in leisure hours, saves expenditure and adds to the wealth of the household, so in a nation everything that is produced, if it does not interfere with other productive labor, also adds to the general wealth. It is quite plain to us that we need not go to France for such mares as this, and equally so that thousands of mules may be raised in several of our States without hindering any profitable work. If, then, we use the mares we have and devote attention to this business, all we need is to import the necessary animals to start with, and set this industry to work for ourselves. It is questionable, indeed, if we do not already possess equally good animals with the French breeders, and if we could not by using the same care as they do in selecting sires and dams produce equally good mules. We have little doubt of it, and knowing what has been done by our breeders in other respects, and the great success they have attained, it

would be strange indeed if they could not produce exactly the kind of mule needed for every purpose, and render importation unnecessary. It will be seen from the engraving and the following description of the Poitou mares that we have already the material for a home supply. The engraving represents a prize Poitou mare, and a mule foal three months old. The mare is 16 hands high, coarse in bone and heavy in build, and very much resembles the horses common in Nor-

mandy, some of which have been brought to this country under the misapplied name of Peheron. Indeed, many mares have been taken directly from Normandy for mule breeders (*mulassiers*), although both stallions and mares are now brought from England to supply a stock of dams. These dams are rarely used to labor, but are kept almost altogether for breeding. Generally they have colts when three years old, and the idea of the French breeders that very low keep upon straw and similar innutritious food is favorable to the process of gestation, and the safe production of the colt does not tend to improve their appearance, although it may be

effective for the purpose designed. Certainly the pampering of breeding animals is neither productive of prolificacy or hardiness in the dam, nor hardiness in the offspring; but on the other hand there is a judicious mean

which is not wisely departed from. The young mule inherits the heavy limbs of the dam and its size, as also to some extent its coarseness; the capacity for draft being the great object to be attained. On the whole the French system of raising these mules is contrary to what we should consider as exactly proper, and it is quite possible that in a very short period we could surpass them in the character of the animals raised. For instance, the young foal is denied the first milk of the dam, and this frequently results in its injury or early death. Then as soon as the colts are weaned they are sold to farmers, who rear them until yearlings, when they are sold again and again to others who keep only mules of two, three, or four years, as the case may be, until finally they are sold to the foreign purchasers. A more enlightened treatment of the mules could not fail to be of service to them, and it is hardly questionable but that American bred mules would be superior to the imported ones.

Walks and Talks on the Farm.—No. 125.

Mr. S. R. Elder, of Beaver Co., Pa., writes me an interesting letter. "Corn is our surest crop," he says, "and always follows a manured clover sod. We usually get about 70 bushels shelled corn per acre. The next spring we sow oats on the corn stubble. And here our trouble commences. The oats fall down and do not fill, and taking one season with another we do not get more than 35 bushels per acre. I once sowed five acres of oats and peas. They had a splendid appearance when in bloom, but fell down and rolled before they showed any signs of ripening. Now, can you suggest any crop to take the place of the oats and leave the land in good condition for winter wheat?"

In this section wheat does better after barley than after oats. I should try plaster or salt to see if it would not give stiffer oat straw. Sow 200 lbs. broadcast per acre after the land is plowed and harrowed in the spring and before the seed is drilled in. If Mr. Elder has been in the habit of drawing his winter-made manure on to his sod land in spring, and plowing it under for corn, I would try the plan of piling the manure and turning it once or twice so as to thoroughly ferment it, and then draw it out in the fall on to the clover sod and plow this clover sod up for corn next spring. I think the oats that followed this corn crop would not be so likely to fall down as they would be on land where coarse, fresh manure was plowed under for corn. I think oats and wheat frequently fall down, not because the land is too rich, but because it is not rich enough. The trouble is probably due to an excessive amount of carbonaceous matter in the soil, and to a deficiency of nitrogen, phosphates, and potash. One of the best remedies for this evil is to grow more root crops. A crop of mangel-wurzel or turnips will take up this carbonaceous matter from the soil and organize it into good nutritious food.

But it is not an easy matter to hit on the best rotation of crops. If we could only get reliable artificial manures at reasonable rates we could farm to much better advantage. The time will come, and that shortly, when such will be the case. We could then adopt any rotation that best suited our particular circumstances. The old notion that there is any real chemical necessity for a rotation of crops is unfounded. Wheat can be grown after wheat, and barley after barley, and corn after corn, pro-

vided we use the necessary manures and get the soil clean and in the right mechanical condition.

"What, then, do we gain by a rotation?" asked the Deacon.

Much every way. A good rotation enables us to clean the land. We can put in different crops at different seasons.

"So we could," broke in the Deacon, "if we sowed wheat after wheat, barley after barley, and corn after corn."

True, but if we sowed winter wheat after winter wheat there would not be time enough to clear the land.

"Just as much as when we sow wheat after oats, or peas, or barley."

"True again, Deacon," I replied, "but we are supposed to have cleaned the land while it was in corn the previous year. I say supposed, because in point of fact one half our farmers do not half clean their land while it is in corn. It is the weak spot in our agriculture. If our land was as clean as it should be to start with, there is no rotation so convenient in this section as corn the first year, barley, peas, or oats the second year, followed by winter wheat seeded down. But to carry out this rotation to the best advantage we need artificial manures."

"But will they pay?" asks the Deacon.

"They will pay well provided we can get them at a fair price and get fair prices for our produce. If we could get a good superphosphate made from Charleston phosphates for 1½ cent per lb., and nitrate of soda for 4 cents per lb., and the German potash salts for ¾ cent per lb., and could get on the average \$1.25 per bushel for barley and \$1.75 for good white wheat we could use these manures to great advantage."

"Nothing like barn-yard manure," says the Deacon.

No doubt on that point, provided it is good manure. Barn-yard manure, whether rich or poor, contains all the elements of plant-food, but there is a great difference between rich and poor manure. The rich manure contains twice or three times as much nitrogen and phosphoric acid as ordinary or poor manure. And this is the reason why artificial manures are valuable in proportion to the nitrogen and phosphoric acid that they contain in an available condition. When we use two or three hundred pounds per acre of a good artificial manure we in effect, directly or indirectly, convert poor manure into rich manure. There is manure in our soil, but it is poor. There is manure in our barn-yards, but it is poor also. Nitrogen and phosphoric acid will make these manures rich. This is the reason why a few pounds of a good artificial manure will produce as great an effect as tons of common manure. Depend upon it, the coming farmer will avail himself of the discoveries of science, and will use more artificial fertilizers.

I have several times alluded to the experiments of Lawes and Gilbert on barley, giving the main facts. For twenty years barley has been grown year after year on the same land. One plot has been left entirely without manure; one plot has had 14 tons of barn-yard manure per acre every year; other plots have had superphosphate of lime; others sulphate of potash, soda, and magnesia, with and without superphosphate. On other plots, nitrate of soda and salts of ammonia have been used, alone, and in connection with superphosphate, and also in connection with salts of potash,

soda, and magnesia. One plot had 2,000 lbs. of rape cake each year per acre, alone, and also in connection with superphosphate, alone, and in connection also with potash, soda, and magnesia alone, and with superphosphate added. The results of the experiments for twenty years have recently been published. They show that we have much to learn—and, what is equally important, a good deal to unlearn. They are, however, on the whole, decidedly encouraging. They show that great crops can be raised, and that it is well worth a farmer's while to study agricultural chemistry.

The crop on the plot that was sown to barley every year for twenty years without manure produced an average of 23 of our bushels per acre and over 1,300 lbs. of straw. This, in itself, is a striking result.

"It must be very rich land," remarks the Deacon.

"No," I replied, "it is no richer land than yours or mine. It is what we should call a rather heavy wheat soil. It is some such land as my north lot, but I think not naturally as rich."

"When you sowed barley in that field, if I remember right," unkindly remarked the Deacon, "you did not get over 15 bushels per acre."

This was not because the land was poor. It was because it had never been more than half plowed and worked, and was full of weeds.

The plot that was manured every year with barn-yard manure averaged 54½ bushels per acre and over 1½ ton of straw. The smallest yield on this plot during the twenty years was 34½ bushels per acre, and the largest yield 65 bushels.

The smallest yield during the twenty years on two plots which received nothing but the best artificial manures was 33½ bushels per acre on the one plot and 39½ bushels on the other. The largest yield on these two plots was 71½ bushels per acre on the one and 73½ bushels on the other.

"That will do," says the Deacon, "but after all it is not as big a crop as your oats and peas last year. You had 85½ bushels per acre, without any artificial manures."

The year before I had 88½ bushels by weight, reckoning a bushel 32 lbs. This would be 2,832 lbs. per acre. Mr. Lawes's largest crop of barley, at 48 lbs. per bushel, was 3,540 lbs. per acre. This, by weight, is equal to over 110½ bushels of oats per acre.

"I suppose," says the Deacon, "that Mr. Lawes had spent a small fortune in underdraining the land."

"It so happens," I replied, "that this field was not artificially drained at all. The only reason for such large crops was the application, in an available condition, of nitrogen and phosphoric acid. But recollect one thing, Deacon, it is vain for you or for me to hope to get big crops until we make our land clean. In a letter just published, Mr. Lawes, in alluding to the fact that nitrate of soda and superphosphate can be used with profit on the barley crop, well says: 'It is hardly necessary to add that the land should be clean; many of the weeds which infest our fields are quite as fond of ammonia and phosphate as are the grain crops, and if allowed to do so they will appropriate to themselves a very considerable portion of the manure.'"

The Deacon got up to go. I have only to speak of "weeds" to start him at any time.

"Don't be in a hurry," I said, "there are

several letters here that I want you to help me to answer. Here is one from Champaign, Ill., from a gentleman who wants to know how many pigs he can keep on an acre of clover."

"If the pigs have nothing but clover," said the Deacon, "they will eat nearly as much as one of your big Cotswold sheep. They keep eating all the time. But a good deal depends on the breed. And I will say one thing in favor of your black pigs. They are the best graziers I ever saw."

That is simply because they are so quiet and have little offal. Restlessness and offal, like weeds in a corn field, run away with half the food and all the profits. There are pigs that weigh no more in the fall after a summer's grazing than they did in the spring. The great advantage of having well-bred pigs is shown in the pasture lot more than in the pig-pen. I am not sure that a coarse, common, ill-bred hog that has nearly got his growth will not gain as fast after he is shut up to fatten as a well-bred Essex or Berkshire. But turn a couple of such pigs at say six months old into a good clover or pasture lot, and the well-bred pig will not only increase the more in weight, but this increase will consist in a good degree of good solid flesh and fat, while the increase of the other will be principally in bone, water, and offal.

A pig will eat more in proportion to live weight than any other domestic animal. Bous-singault states that a pig from six to eight months old will eat green clover equal to over five pounds of hay per day. We shall not be far wrong in assuming that young clover contains 80 per cent of water, so that a pig would eat 25 lbs. of green clover per day—20 lbs. of which consists of water. If we assume that the pasture will produce in the season clover and grass equal to 2½ tons of hay, an acre would support five pigs for six months.

The Deacon thinks they would not eat so much clover if they were allowed one or two pounds of corn each per day. I think they would eat nearly or quite as much. In one of Mr. Lawes's experiments he gave one pen of pigs 28 lbs. of grain per head per week and all the bran they would eat; and to another pen only 19½ lbs. of grain and all the bran they would eat. But the pigs having the smaller allowance of grain ate no more bran than the other. Both pens ate 18 lbs. of bran each pig per week. And so I think it would be with the clover. The pigs will eat about all the clover they can get into their stomachs, say 25 lbs. per day. But I think they would manage to squeeze in an extra pint of corn night and morning.

"But what is the good?" asked the Deacon.

Let Mr. Lawes's experiment alluded to above answer. The pen that had 18 lbs. of bran (all they would eat) and 19½ lbs. of grain gained 4.16 lbs. per week; while the pen that had 18 lbs. of bran and 28 lbs. of grain gained 7.42 lbs. per week. In other words, 8½ lbs. of extra grain per week produced 3½ lbs. of pork.

The next letter is from a well-known agricultural writer in Ohio. He wants to know what is the best work on agricultural chemistry. I told him to get Prof. S. W. Johnson's works, "How Crops Grow" and "How Crops Feed." "I have not time to go at all deeply into the subject," he writes, "but I am convinced that there must be more science and more brains infused into our agriculture before there can be much improvement or even a check to the

downward progress of our crops and the fertility of our soils."

I have not much fear of a "downward progress." I do not think our soils are being exhausted. I know my farm will produce a great deal more now than it would 25 years ago. Take the field where I am now sowing 14 acres of mangels. Twenty-three years ago it was in wheat. My father, who was a good English farmer, walked over the field with me, and exclaimed, "I never saw such a wretched crop; but it looks like good land." Last year I had a grand crop of corn on this same field. And yet about all I have done to it is to get out some of the stones, plow it better, cultivate thoroughly, and kill the weeds. I have plowed under no clover, have not put fifty loads of manure all told on the whole field until this spring. Now I am putting on eight or ten tons of manure per acre, and expect, with a favorable season, a fair crop of mangels.

"J. S. D.," of Bartholomew Co., Ind., asks "if Diehl wheat is an early or late variety? smooth or bearded? has it stiff straw, and is it suitable for the rich bottom lands of Indiana? Is it liable to be struck by rust or attacked by the fly? Is it a hardy winter wheat?"

It is early, not bearded, very stiff straw. With me it has escaped the midge and rust. Last year it was badly killed by the winter, but not more so than other varieties of white wheat. Mediterranean and other red wheats suffered less; so much so that many of our farmers did not sow white wheat last fall, but have gone back to the Mediterranean. The truth of the matter is just this. If your land is not dry enough or rich enough to produce twenty bushels of Mediterranean wheat per acre in a favorable season, it is useless to sow Diehl or any other choice white variety. But if your land is too rich for Mediterranean, and is dry and otherwise in good order, try the Diehl. You will be likely to get a larger yield per acre and a higher price per bushel.

A farmer in Ohio writes: "I have just sold twenty-nine black-walnut trees to a man in New York for \$600. My neighbors think it will hurt the sale of my farm. I look at it in a different light. That six hundred dollars will enable me to add many conveniences and some necessities. Such timber is too expensive to split into rails. Fully two thirds of the rails on the farm are black-walnut."

When a man does not wish to sell, what is the use of this constant talk about this or that thing helping or hindering the sale of the farm? If the black-walnut trees have got their growth, sell them and spend the money in making such improvements as will add to your own comfort and to the real value of the farm. To split up black-walnut trees into rails is about as sensible as it is to feed out clover seed to sheep or to plow it under for manure.

This same correspondent says he has "half an acre of mallows, or what the boys call cheeses. I cut it up six times last summer, and in the fall had a splendid crop. Will salt kill it?"

I think not. It is a wretched weed. I have been fighting it for years. It does not seem to fear the hoe. It must be pulled up by the root—which is easier said than done. During last winter we had such mild weather that the land could be plowed, and I struck the plow into a patch of land full of this weed and turned up

the roots. All I can say at present is that they do not seem to like this treatment.

The next letter is from a farmer in Pennsylvania, who asks if it is better to fatten grade Cotswold lambs the first winter, or summer them over.

It depends on circumstances. Unless they are remarkably good lambs, and with more than one cross of Cotswold blood in them, I am inclined to think it will be better to keep them over. You get the wool, and it is not necessary to feed so much grain. They will make capital sheep the next winter or spring. When lambs are to be fattened the first winter it is necessary to have them come early, and to push them along rapidly through the summer and autumn; they ought to have some roots in winter.

"Is the Thomas harrow," asks "S. R. E.," "as good as claimed in corn working?"

It certainly kills a great many seedling weeds, and, so far as my experience goes, it does not pull up the corn to any serious extent. If the land is very hard it will not do much good, and if it is very light and rough it will smother some of the plants. Still, I think it a very useful implement, and one I should not like to dispense with. The only trouble I have had with it is with the couplings breaking or coming loose, and sometimes the harrows ride each other. I think the harrow might be improved in this respect. I ought to say that I have had my harrow some years, and it is very likely that this trouble has since been remedied.

A Butter Factory.

The factory system which has been so successful in the manufacture of cheese is equally adapted to the manufacture of butter. The creameries, as the butter factories are called, have made an excellent reputation in the butter markets, and "creamery pails" bring the highest current rates. Concentrated effort and capital are brought to bear in producing butter with the most complete economy and of the greatest possible excellence. The appliances necessary are in no way different from those belonging to any private dairy, except in capacity. The building needed is only an enlarged dairy house, and the principles upon which it is constructed are those upon which any dairy depends for its success. Still, as experience has been gained, there is found to be a style of building which is best suited for the purpose, and internal arrangements which are the most economical and convenient. Such a building is shown in the engravings. Fig. 2 gives the elevation of a successful factory in central New York. The building is 60 feet long, 30 feet wide, and 18 feet to the eaves. The basement or cellar is only partly below the surface of the ground, and is built of stone with hollow walls; the floor is paved with flagstone laid in cement. This secures a perfectly dry, cool, sweet cellar, with an equable temperature throughout the year. The building above the basement is of frame, boarded outside and lathed and plastered within. There is a covered drive-way at one end for delivering the milk, and a covered porch in the front with steps leading to the front door, and below the porch is the basement door. The floor of the factory consists of a milk-room 30 × 36, a work-room 22 × 14, a churning-room 8 × 14, with an engine-room attached. The plan is shown at

fig. 1. The milk-room contains twelve large pans each 10 ft. 10 in. long by 4 ft. 3 in. wide and 7 in. deep. They are what is known as the Jewett pan, which is made with a double bottom with a half-inch water space divided into

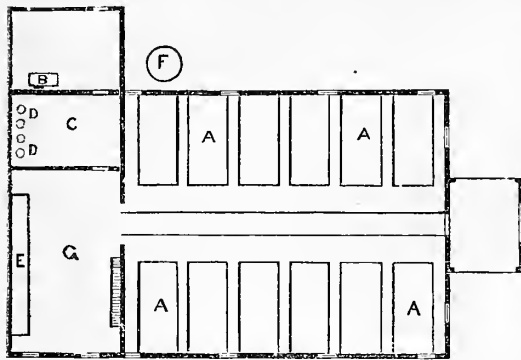

Fig. 1.—PLAN OF BUTTER FACTORY.

channels open and closed at alternate ends, so that the water which passes underneath the milk for the purpose of cooling it runs in a suddenly reversed current back and forth until it is discharged at the end opposite to that at which it enters. The entrance and discharge pipes are both raised above the level of the false bottom upon which the milk rests, so that the water space is always completely filled.

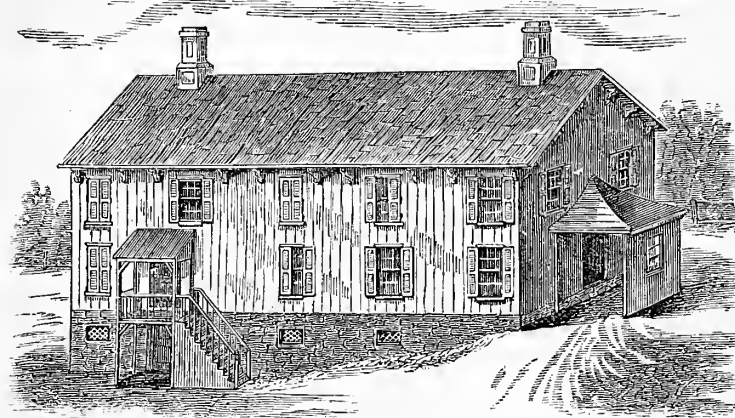

Fig. 2.—ELEVATION OF FACTORY.

The pan is a complete structure having no loose parts, and rests upon a wooden table. Figure 3 shows the form and arrangement of these pans. There are several other styles of pans in use in other factories, and some fac-

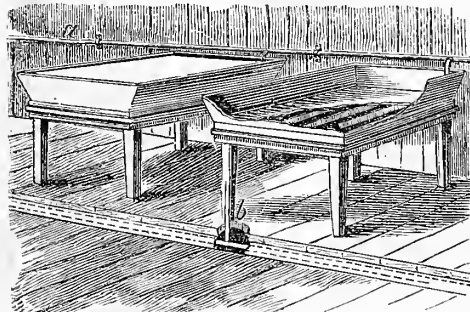

Fig. 3.—JEWETT MILK PANS.

ories practice the deep-can system, which has been frequently described in our columns. In the engraving (fig. 3) the pipe is shown at *a* by which the water is brought into the pans. It is brought from a spring near by at a temperature of 48°, and cools the milk to a temperature of 60° in the course of four hours. The milk-room is warmed to the same temperature in winter by means of steam pipes which pass through it. At *b* is seen the pipe which carries off the overflow of water from the pans, and which passes down by one of the legs of the table. A por-

tion of the floor is removed to show this pipe. These pans shown at *A A*, fig. 1, are placed 20 inches apart upon each side of the room. A rail track is laid in the center of the room between the pans, upon which a hand-car is

run, which carries the milk from the receiving door. The milk is received into a weighing can, the can rests upon the car, which is higher than the pans, and the milk is run from the can directly into the pans. At *B* is the boiler and engine. The Anderson boiler is the one used and is eight-horse power. At *C* is the churning-room, in which common upright dash churns,

D, D, are worked by steam power. The sink, 12 feet by 3 feet, is seen at *E*. At *F* is the sour milk tank, and at *G* is the work-room. The milk pans, *A, A*, contain 200 gallons each, or the milk of 100 cows at one milking; milk is received at this factory from 300 cows. The twelve pans and fixtures cost about \$700, and the whole building with all the apparatus complete cost nearly \$4,000. The upper story is used for the dwelling apartments of the super-

tendent, and the whole building is neatly painted outside and whitewashed inside. The perfect cleanliness and order usual in the best private dairies are to be provided for in any factory building, and such a location must be chosen as will secure purity of atmosphere, good drainage, and a central position amongst its patrons. The cost of making butter at

this factory is three cents a pound, and twenty-eight pounds of milk upon the average are required for each pound of butter.

The ground plan of a private dairy of 75 cows, owned by Mr. P. D. Merriam, of West Port, N. Y., is shown in fig. 4. The milk-room, *A*, is 30 x 18 feet; *B* is the ice-water tank which supplies the pans, *C, C, C, C*, of the Jewett pattern, with cold water. These pans are 11 feet long by 3½ in width. *D* is the churning room, 15 x 8 feet; *E*, the sour-milk room, is 8 x 5; *F* is the sour-milk tank; at *G* is the wash-room, 12 x 8, which contains a stove and scales; at *H* is the butter and cream room, 2 x 12; and at *I* the ice-house, 10 x 12. Mr. Merriam makes choice butter for the Boston market, and speaks very favorably of the large pans, for convenience, saving of labor, and larger yield of butter than in the small pans. He states that the saving of labor is one half, and the butter made with these pans is superior both in quality and quantity.

The Grubber.

Since the introduction of steam power in the cultivation of land a new system of plowing has come into use. The idea that when the term plowing is used the inverting of the soil as by the ordinary plow is meant, is no longer correct. A very large proportion of the steam

plowing done in England and other countries at this time does not invert the soil at all, but merely pulverizes it. This operation is performed by what are known as grubbers. These implements, drawn by horses, have been in use

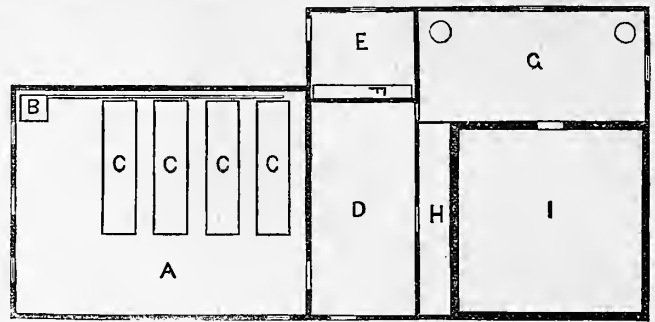

Fig. 4.—PLAN OF MR. MERRIAM'S DAIRY.

for many years as aids to the plow in breaking up the subsoil and mellowing the surface soil, but have only recently been substituted for the common plow altogether. Now that it has been found that very satisfactory crops may be

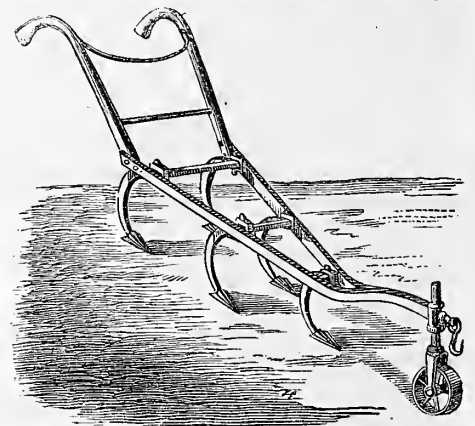

Fig. 1.—THE GRUBBER.

raised by the use of these implements upon stubbles or fallows, when operated by steam, they are coming into use in place of plows drawn by horses. No root crop is sown until the ground has been thoroughly worked with these implements. They are also coming into use in this country. One farmer of our acquaintance uses one to follow the plow, and breaks up the subsoil to a depth of twelve inches. His farm has a very light soil. Another uses one in preparing his land for potatoes and also in cultivating between the rows as soon as the plants appear above the ground.

There are many other opportunities of making these implements useful. Fall-plowed land could be worked with one of them in the spring, instead of cross plowing, with great advantage and economy. They would entirely obviate the necessity for subsoil plows, as they would do the same work much more rapidly. They would

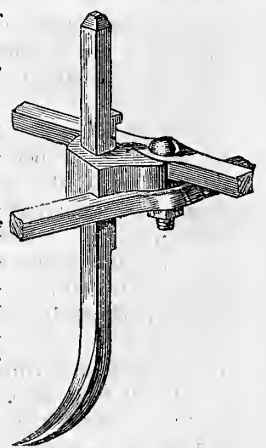

Fig. 2.—TOOTH.

prepare a corn stubble for a fall wheat crop much better than is now done by the surface harrowing common throughout the Western States, and would undoubtedly tend to increase the yield. As a cultivator to break up between the rows of corn or potatoes they

would do the work in half the time of the plow. The annexed engravings show the forms of the teeth generally used and the smallest-sized grubber. Fig. 3 is a tooth intended to fit upon

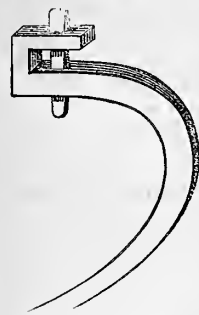

Fig. 3.—TOOTH.

the bars of the frame by means of a key which passes through the bar, and to carry a winged share which penetrates and lifts and loosens the subsoil. Fig. 2 is a tooth which is clamped upon the frame by means of bolts, and simply stirs the soil. Fig. 1 shows the frame, which is similar to that of an ordinary cultivator, and to which either of the above forms of teeth may be affixed. We know of no person who makes these implements at the present time, but as the teeth are of wrought iron any fair blacksmith should be able to make them. The frame is made of timber strengthened by bolts. A farmer whom we visited some time ago was using a similar implement, the teeth of which were ordinary picks, and he expressed himself as being very much pleased with its effect, both in preparing for crops and cultivating them.

How to Make Hurdles.

The picture in April of the "lamb creep" formed of hurdles has brought us several

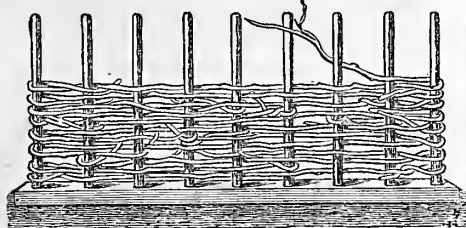

Fig. 1.—MAKING A HURDLE.

inquiries as to the best method of making the hurdles for portable fencing. For this purpose they are very useful, and as they are quickly and cheaply made and last, when taken care of, many years they are very economical. The material is generally such as is of little or no use for any other purpose. Brush from fence rows, swamps, river or creek banks, or the undergrowth of woods

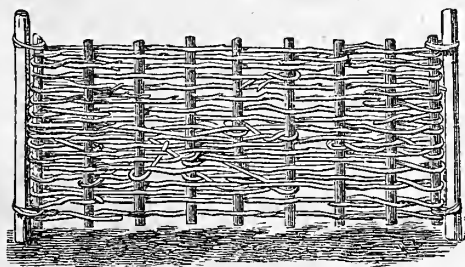

Fig. 2.—A HURDLE SET UP.

is what is wanted. The thicker portion of this is cut into stakes five feet long and trimmed of all branches. A piece of scantling 10 feet long is provided, and holes 18 or 24 inches apart are bored in it. The stakes are set upright in these holes, and while in this position the smaller brush is interwoven between them. Figure 1 shows the method in which this is done. When the hurdle is completed it is set up in the fence in the following manner. The stoutest of the stakes are reserved and pointed at each end. These are driven into the ground at such dis-

tances apart as may be needed, so that the hurdles may be fastened to them. Generally one at each end of the hurdle is sufficient, or another in the middle of each one may be used. The hurdles are then tied to the stakes by withes, cords, or wires. Holes are left in the hurdles at each end for this purpose. Figure 2 shows the method of setting up this fence.

A Lard-Oil Press.

The home manufacture of lard oil is a process that may profitably be carried on under some circumstances. Those who may find it convenient to make their own lubricating or burning oil or manufacture it for sale may make use of the simple contrivance here described by "E. K. G." of Holliston, Mass. It consists of a frame made by fitting two pieces of timber 4 x 6 inches thick from the floor to the roof or ceiling of an apartment at least 10 x 20 feet in size. Holes 1 1/2 inch in diameter are bored through the timbers 15 inches apart, and an iron bolt is made to fit them. A press bed is then made of plank three inches thick, 18 inches wide, and four feet long, with a gutter cut out all around it, which leads to a pipe that passes into a cistern below. The bed is placed in front of the upright pieces. Two other upright timbers 4 x 10 are placed upon the bed three feet apart and framed into it and fastened above. A guide one inch thick and two inches wide is fastened to the inside of each of these uprights, and a follower, shown at *a* in the engraving, is made to fit them. A lever 15 feet long and 4 inches thick, 10 inches wide at one end and 6 inches at the other, is made; and a hook affixed to the small end, on which a box may be hung to receive a burden of stone or other heavy material. The press is then ready for use. The lard is prepared by being packed in a box 10 inches square and 3 inches deep, in which a small sheet of strong cotton cloth has been laid. When the box is packed full of lard the cloth is folded over the top of it. The package of lard is then taken out and laid upon the press bed. More lard is prepared the same way, and the packs are placed in pairs, a piece of board being laid upon each pair. When enough has been prepared, a heavy follower which fits the guides is placed upon it, and a wooden saddle or rocker is put upon the follower, and the lever is then arranged so as to press upon the saddle. Weights are then placed in the box. The oil which is pressed from the lard runs down through the pipe into the tank beneath. As the lard is pressed down the pin at the end of the lever is lowered one or more holes as may be needed. The oil made in such a press in the winter time will be of the best quality.

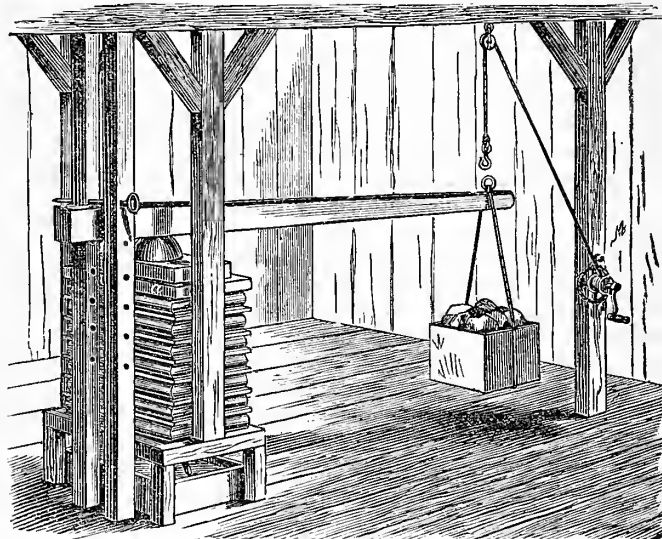

A LARD-OIL PRESS.

deep, which would hold 105 barrels, or 10 1/2 barrels of water, or 375 gallons for every foot in depth. This quantity of water would supply a moderate number of stock for three months; at least it would give one barrel of

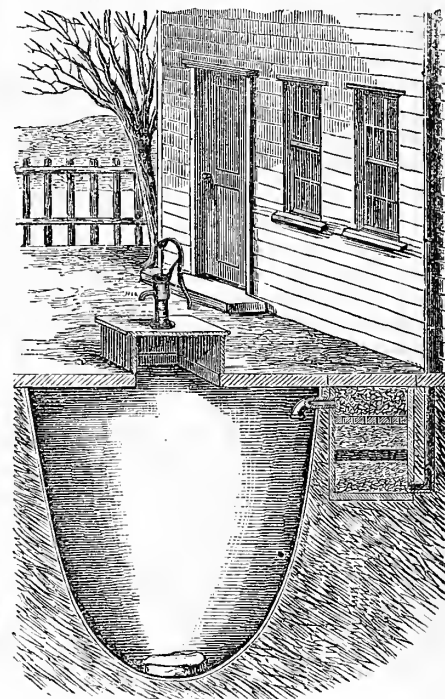

SECTION OF A CISTERN.

water a day for 100 days, even should no considerable shower fall within that time. If a larger supply were needed we would rather build several cisterns than one large one, as being more secure against accident. The most economical cistern, both as to cost and space, is a cylindrical one, that is, a round one with straight sides. In a clay soil such a one may be very safely made, but where the soil is

An Underground Cistern.

A capacious cistern is next in value to a good well, and is better than a failing one. It may be constructed with but little labor, and the expense, as compared with its convenience, is small. If every western farm had a cistern at

coarse, compact gravel, it is better to make it somewhat spreading at the sides, or bell-shaped, and similar to that in the engraving. The situation should be chosen in the most convenient place, as it is easier to lay a pipe to it than to carry water from it. The digging should be smoothly done, or there will be waste of cement in the plastering. When the whole is dug the cement may be prepared. This should be water lime or hydraulic cement. Our native Rosendale cement will answer the purpose very well, but if expense is no object, and the best work is desired, we would finish with a thin coating of imported Portland cement. This costs three times as much as Rosendale cement, being worth about \$5 a barrel, while the other is about \$1.75. The cement should be mixed dry, as evenly as possible, with seven times its bulk of clean, sharp sand. As it is needed it may be mixed with water upon the floor of the cistern, so as to become a soft mortar and be immediately spread. A flat stone large enough to stand upon, or several of them, should be laid in the bottom of the cistern, and bedded in the cement. Then the sides should be plastered at least an inch thick, or somewhat thicker at the bottom, in streaks all round the cistern, going regularly around in a spiral, taking care to make the joints very accurately, and leaving scratches to receive the finishing coat. In this way it is finished to the top. After it is done a light coat, with half as much sand as before, is laid over it and smoothly finished. When this is done a thin coat of pure cement, made as thick as whitewash, is laid on with a brush. A covering of joists and plank is laid over the top, and water may be run in at any time, the sooner the better. If any cracks appear before the water comes in they should be carefully filled with the cement wash by means of the brush. The accompanying engraving shows the shape of the cistern which is best fitted for gravelly soil. In stiff clay the shape is not of great importance. In sandy soil the walls of the cistern must be bricked before cementing.

For domestic use a waste shoe should be provided to be hung upon the lead spout from the roof, for the purpose of carrying off the first run of water, which is very apt to taste badly. After the roof and spouts are washed clean, the shoe may be removed and the water turned into the cistern pipe. It is well also to clean out the gutters occasionally and remove dead leaves and dirt. A filter should be attached to the house cistern, made of a wooden or cemented box, two feet square, into the bottom of which the lead pipe discharges. Layers of coarse gravel, sand and pounded charcoal are placed in the box and covered with a slate or a slab of cement pierced with holes. Upon this slab a layer of coarse gravel is placed. The water passes through all these and is freed from ill tastes and color. The engraving shows the manner of making the filter.

Ear-Marks for Stock.

There are various methods in use for marking and numbering animals so that they may be readily distinguished by the breeder. In a recent number of the London Field we find a system described which has been invented by a German breeder, Von Thaer. It consists in the use of three marks only, which may be so combined as to indicate very clearly any number up to 10,000. These marks are, first, a notch in the side of the ear; second, the tip of the ear cut

squarely off, and third, a hole in the ear. Each mark has an arbitrary value which changes according to its position upon the ear, or either ear, and the sum of the values represents the number of the animal which bears the marks. A notch on the front of the left ear stands for 1, two such notches stand for 2; a back notch on the same ear stands for 3, two such notches stand for six; one notch in the back and one in the front of the left ear stand for 4, and combinations of these notches mark up to 9; a front notch upon the right ear marks 10, and a back or outside notch marks 30; combina-

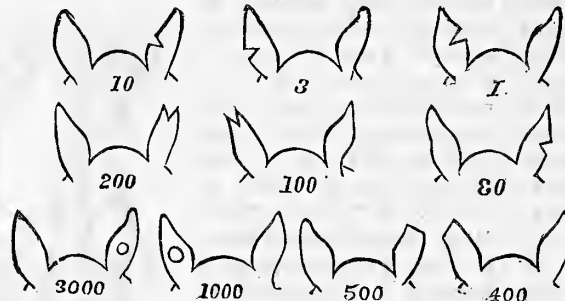

Fig. 1.—EAR-MARKS FOR ANIMALS.

tions of these notches upon this ear mark up to 90, and with those upon the other ear up to 99; a notch upon the tip of the left ear marks 100, one upon the tip of the right ear 200, and these two together 300; a square cut, off from the tip of the left ear, is 400, and from the right ear marks 500; this last mark with the notch in the tip of the left ear marks 600; the tips cut square from both ears mark 900. Thus we have marks up to 999, and the third comes into use. This is a circular hole which, in the left ear, marks 1,000, and in the right ear marks 3,000. By combining these marks any number up to 10,000 may be represented. We append the following engravings of various marks, with the values represented by them. A simple pair of pincers, provided with the required cutters, is the only tool needed. A register of the stock of course will be kept in which the character of the animals will be recorded opposite their particular number. This system is



Fig. 2.—EAR-MARKS FOR ANIMALS.

well adapted in cases where stock is running at large and is in danger of tearing out the ear marks made by inserting rings or bands bearing letters or numbers. Where stock is carefully kept the Dana ear-marks here shown may be made very useful. Careful breeders find it quite necessary to be able to distinguish each individual of their herds. When a calf in a large herd is removed from its dam to be



Fig. 3.—DANA'S EAR-MARKS.

weaned, its identity becomes lost unless a mark is put into its ear. Upon the western plains the usual brands must give place to these me-

tallic ear marks, at least for horned stock, while those previously described will serve admirably for sheep. The metallic ear marks, stamped with the owner's private brand, will be a readily distinguished mark; upon male animals they may be placed longitudinally in the ear, and upon females they may be placed crosswise, as shown in the accompanying figures.

A Smoothing Drag.

E. W. Greene, North Andover, Mass., sends us a sketch of a smoothing drag which is used extensively in his neighborhood instead of a roller. It is eight feet long, and made of two-inch plank. The bottom is two feet wide on the flat, and a plank twelve inches wide is placed in front at such an angle as will enable the drag to ride over the ground and crush all rough clods without pushing them ahead. The sides are made of 4x4 scantling, beveled at one end to fit the front plank. A chain is fastened to the front by hooks, and when in use the driver rides. In addition to

its use as a clod-crusher, it will be found very convenient in gathering rubbish and roots of



A SMOOTHING DRAG.

grass or other weeds from plowed ground. The accompanying engraving shows the drag ready for use.

Our Supply of Salmon Spawn.

It is only four years ago that we were obliged to send to the government hatching house on Wilmot's Creek, near Newcastle, Canada, for salmon eggs, and get them as a special favor, at \$40 a thousand, gold. So jealous were the Canadian authorities of all intrusion into their territory for salmon spawn, that the hatching works on the Migamichi River were broken up, and we had to purchase at the Wilmot establishment, or go without.

Fortunately there were a few rivers in Maine that yielded salmon, and it was thought possible to get a supply from the Penobscot, where some six or eight thousand were taken annually by fishermen. There had been a successful experiment of taking land locked salmon spawn at Grand Lake Stream in Maine, in the fall of 1870, by catching and pounding the salmon during the fall until they were ready to spawn in November. From this it was inferred that the Salmo Salar might be taken alive from the weirs on the Penobscot during the summer, and kept securely in ponds, until the spawning season. A company was organized of the Fish Commissioners of Maine, Massachusetts, and Connecticut, and the Poquonoc Fish Company, who agreed to meet the expenses of an experiment near Bricksport, Maine, under the direction of Chas. G. Atkins, Esq., one of the Maine Commissioners. The first year about 72,000 eggs were taken, and the price of eggs to the parties was found to be about eighteen dollars a thousand. The second year, an ap-

propriation having been obtained from Congress, Prof. Spencer F. Baird, U. S. Fish Commissioner, took stock in the enterprise, operations were enlarged, and 1,500,000 eggs were secured, at a cost of about five dollars a thousand. This last fall there was a still larger investment in salmon, and about 2,250,000 were secured, at a reduced price per thousand. These eggs will be hatched and distributed mainly in the rivers of New England. Beside these over a million of eggs of the Sacramento salmon were taken by Livingston Stone, Esq., under direction of Prof. Baird. These, we learn, are destined for the Delaware, and Susquehannah, and streams farther south, to which this species is thought to be adapted. The country is to be congratulated upon this early and abundant supply of salmon spawn within our own borders. The main difficulties in the way of stocking our barren rivers with this delicious fish are already overcome and cheap salmon are not far in the future.

Care of Young Chickens.

F. J. Kinney, Worcester, Mass., sends us his method of raising chickens as follows: The eggs are placed beneath the hens in boxes in the bottom of which dry earth is placed six inches deep. In very cold weather a newspaper folded two or three times is placed upon the earth. Then two or three inches of fine chaff is laid in the box, and the eggs are placed upon it. As the chicks are hatched they are removed, and fresh eggs are placed in the nest. Some hens thus hatch 45 chickens each. Five or six hens are set at a time, which bring out eight to eleven chickens each. Fifty of these chicks are put together into a cheese-box which will hold a 50 lbs. cheese. A hole is cut in the box to let them in and out after they are four days old (see fig. 1), and one inch in depth of clean, dry, coarse plastering sand is scattered in each box. The chicks are fed with thin cakes made of sifted corn-meal and sweet skimmed milk and baked hard. The cakes are pounded fine

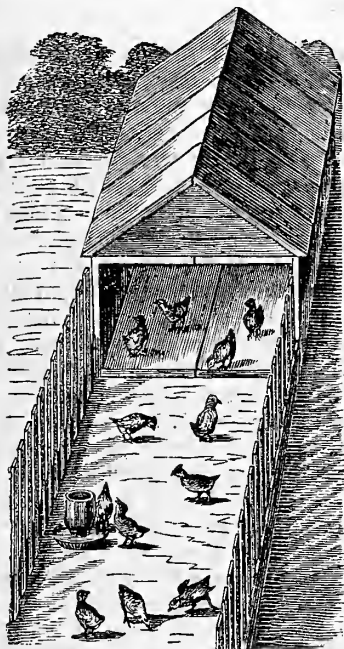

Fig. 2.—RUN FOR CHICKENS.

in a mortar, and with each pint the hard-boiled yolks of two eggs are mixed. This quantity serves to feed 50 chicks each day for the first two days; the next two days 1½ pint and four yolks are given, and the next two days one quart and six yolks. After this some boiled

meat, wheat screenings, cracked wheat, and corn are given four times a day, in addition to the pounded cakes three times a day, until the chicks are a month old. No soft feed is given. When six weeks old the pullets are separated from the cockerels, and they are each placed 25 to 50 together in separate runs. These are made of dry-goods boxes about four feet long, 2½ feet high, and two feet wide. One side and one end are knocked out from each box, and two are placed together so as to form one open box (shown at figure 2). These are covered with tight roofs of matched boards, and in front of each is placed a fence made of boards sixteen feet long and six inches wide, to which are nailed, one inch apart, common plastering laths cut in two. These runs can easily be moved about, and dry earth, charcoal, feed, or any other thing is easily put into them. Earthen fountains containing two quarts are used, are emptied every night, refilled each morning, and the saucer rinsed out each noon. Holes are cut in the tops of the boxes, so that by removing the roof the chickens may be gathered into a small compass when necessary.

For early chickens a frame may be used (fig. 3). It is made like a hot-bed large enough for three sashes, thirty inches high at the back and fifteen inches at the front. The center only is covered with a sash, the rest of the top

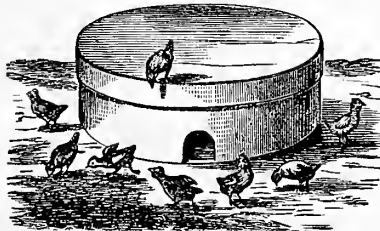

Fig. 1.—CHEESE-BOX FOR CHICKENS.

is covered with a roof of matched boards. The frame is placed at the south side of a tight board fence, and the ground inside is raised four inches with dry clean sand and gravel. Fifty early chickens may be raised in this bed without trouble, and if they are brown Leghorns, and are hatched in March and April, they will bring at eight weeks old 50c. to 75c. a pound for broilers, and the cockerels will weigh two pounds each on the average.

The following is the account for 50 chickens hatched April 27th, 1873, and sold at eight weeks old:

50 chickens, at \$1.25.....	\$62.50
1 bushel screenings.....	\$1.00
2 dozen eggs.....	80
1 bushel meal.....	1.00
60 quarts skimmed milk.....	1 50
½ bushel onions.....	1.50
5 bushels small potatoes.....	2.00
100 lbs. cabbage.....	3.00
1 bushel cracked corn.....	50
6 dozen eggs set.....	2.40
Feed of hens.....	1.00
	—\$14.70
Profit	\$47.80

The manure pays more than the cost of frames and care.

The hens need to be carefully managed. They require green feed, meat, a variety of grain daily, with pure fresh water, sand, crushed shells, and bones, dry ashes or earth to wallow in, and plenty of light and ventilation. Ten hens with one thorough-bred cock may be kept in a room 18 by 6 feet perfectly clean and free from unpleasant smell, and each hen may be made to hatch out 45 chickens. Of the chickens hatched nine out of every ten may be raised by using the plan previously described. The yellow Western corn, cracked, is the best

standard feed. Shorts scalded with the water the meat is boiled in, and fed warm, should be given to the laying hens. Full grown fowls should get two ounces of meat a day, all at once, in the morning, during the cold weather, and in two portions in the summer. Onions

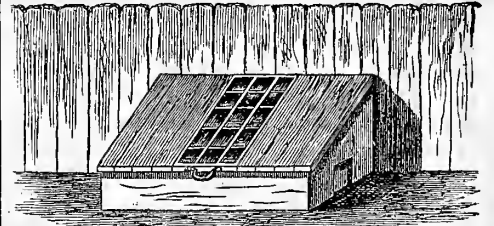

Fig. 3.—FRAME FOR CHICKENS.

are very desirable feed, and every day some should be given along with raw potatoes or turnips pounded fine. Cabbage is excellent but costly. Fowls should be fed thrice a day, and in warm weather fresh water should be given as often.

The following is an account of the expense and receipts of 28 hens with their progeny, including the present value of the chickens raised, during the past year. All the figures are taken from the account book except those relating to the manure, which are estimated:

22 Brown Leghorn and Worcester Co. fowls, at \$5.00.....	\$110.00
6 mixed hens, at \$1.25	7.50
100 bushels grain.....	100.00
2,000 lbs. meat, at 1½c. a lb.....	30.00
3,000 lbs. vegetables, at 1c.....	30.00
Care, at 30c. a day.....	109.50
House rent and incidentals.....	30.00
	—\$417.00
Cr.	
407½ dozen eggs, at 40c.....	\$163.00
Eggs sold to hatch.....	27.50
Chickens sold for poultry.....	98.78
Chickens sold to breed from.....	262.00
100 B. L. hens in yards.....	500.00
18 crowsers, at \$5.00.....	90.00
5 Worcester Co. crowsers.....	25.00
20 Worcester Co. hens.....	100.00
33 mixed hens for sitting, at \$1.25.....	41.25
2 tons manure, at \$60.00.....	120.00
	—\$1,427.53

The Sod House.

The sod house of the prairie or the plains is the counterpart of the log house of the backwoods. Each is the rough-and-ready dwelling made of such material as comes most easily to the hand in a locality where the settler has nothing but his own skill and the native resources of the country to help him. Each is the home of a hardy, industrious, worthy representative of the spirit of adventure and enterprise, who carves a home for himself out of the wilderness. Each frequently shelters beneath its roof a settler who is poor in everything but hope and determination to succeed, but yet in each we have seen a home where an intelligent family has lived for a time in comfort and has enjoyed many of the advantages of what is called civilized life. Books, pictures, and music are sometimes seen in such habitations, occupied by well-educated and intelligent settlers, who for the sake of advancing the interests of their children have chosen to undergo many privations and some temporary hardships. In the interiors of some such houses as the one here pictured, well-filled book-shelves, a musical instrument, newspapers and magazines may be seen, and yet the floor may be of earth and the chimney of sticks plastered with mud. Yet the hopeful anticipations of future prosperity keep the tenants of these rough habitations in cheerful spirits, and each field broken and

planted and each tree started into growth repays all its cost of discomfort. Many of the

If the ground slopes towards the dwelling in any one direction there is danger that some heavy rain may swamp it completely, and if the cabin is a "dug out" the basement will be filled with water. Frequently this danger is not discovered until the misfortune occurs, and then it is too late. In building up the sods the joints should be broken, especially at the corners of the building, or cracks will open as the structure settles. In winter time these cracks will be found inconvenient. As these buildings are only intended to be temporary, the stables and out-houses

general, it is far from wise for a new settler to ignore the fact that his neighbors frequently know more than he does himself, and that it is the part of wisdom to receive advice, and indeed to ask it, especially if the settler is from a foreign country and is unused to the ways and the necessities of his newly-chosen locality.

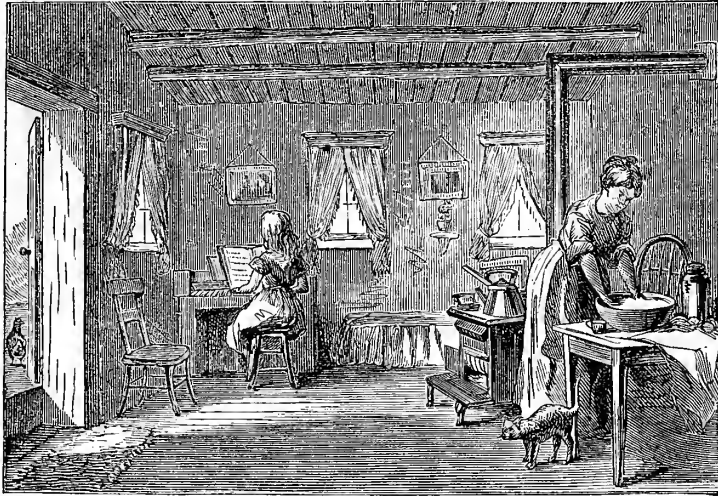

SOD HOUSE—INTERIOR.

most cheerful and congratulatory letters we receive come from such habitations, and only recently one came from a sod house in Nebraska, written by a lady who cheerfully described the earthen floor of her cabin, and remarked that if she and her young children were to choose, she and they would many times rather keep the earthen floor than miss the *Agriculturist's* monthly visits to them. Doubtless there is sunshine in that cabin whatever there may be outside of it, and the incident helps to recall to us the remembrance of several such homes upon the unbounded prairie from whence we have seen neatly dressed children issue, singing and frolicing on their way to school, or from which we have heard the sounds of music as we rode past. But while all this and sometimes the reverse is often true, there is a practical sense in which the sod house should be considered; for if the floor is wet, and the roof leaks, and the walls are suspiciously unsafe, the most cheerful-minded woman will lose her good-nature and contentment, and the chief support of the household being withdrawn disorder and discomfort reign therein. The choice of situation for the dwelling is the first consideration. This should be a spot from which the ground slopes in every direction. There

should be placed as near to them as may be; and for protection against the few severe storms that may occur in winter, when it may

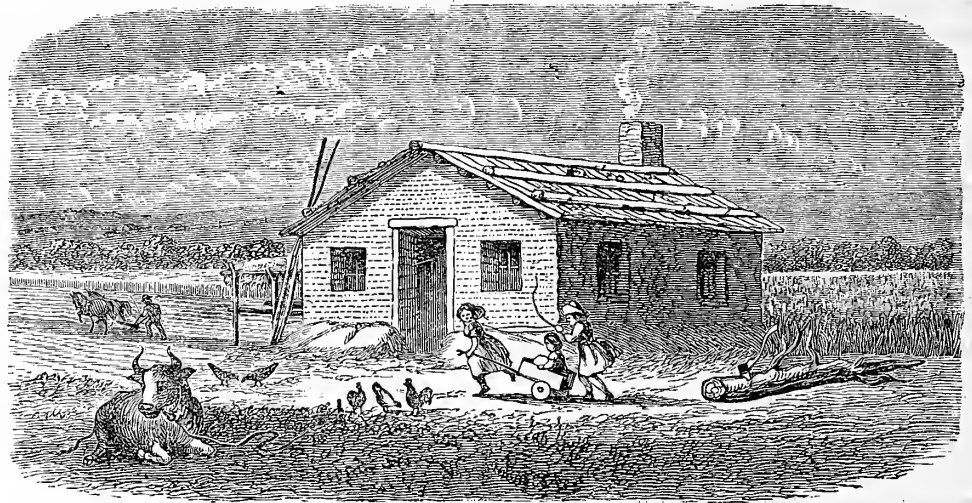

SOD HOUSE—EXTERIOR.

be unsafe to be at a distance from the house, a shelter of sods or some other material should be made to protect the passage from the house

fixed to an upright shaft, and the movable stone is fixed upon this shaft, making but sixty revolutions per minute. There are no bolts in the mill; the only grain ground is oats, and each farmer who carries his grain thither grinds his own grist, which runs from the stones upon the floor, from which it is swept up and taken home in the bags in which it was brought. If this process is rough and inconvenient, the farming upon these islands is equally rough and surrounded with hardships. Oats are the staple, or rather the only grain which ripens, and sometimes this crop fails to mature, or the season is so unpropitious that it can not be gathered, but remains in the shock far into the next season before it can be dried sufficiently to thrash, or is sometimes totally lost. The herbage is scanty but nutritious, and sustains the very diminutive ponies, which are the only horses upon the islands, a few very small cows, which give three quarts of milk per day during a short season, and very short-wooled sheep, some of which are not much better than goats. The winter lasts six months, and the agricultural operations of the inhabitants are supplemented by fishing, which is rendered hazardous by the frequent storms. We doubt if there is one farmer in our highly favored country whose position would be bettered by changing places with the most prosperous Shetlander.

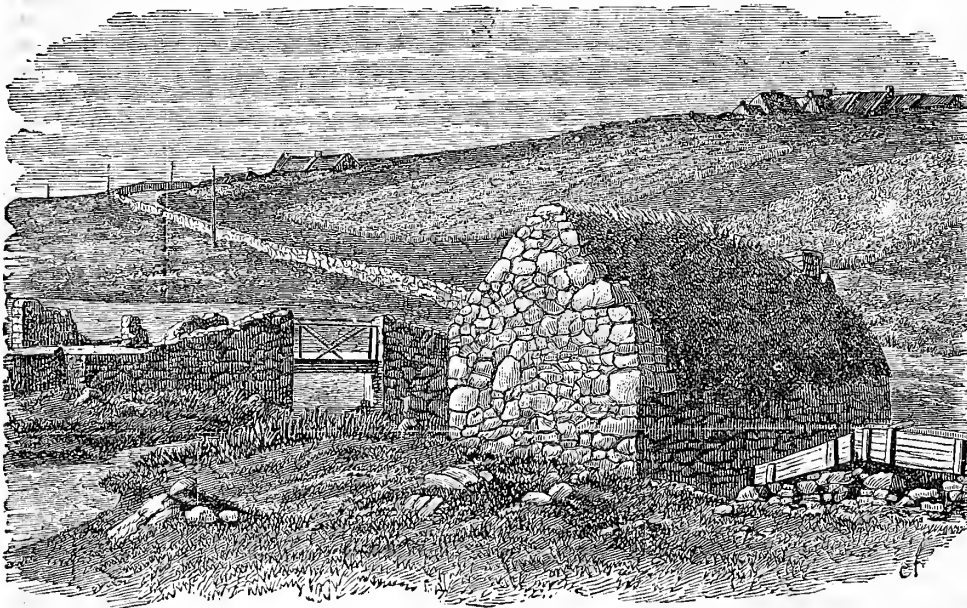

A SHETLAND GRIST-MILL.

should be no hollows near, for in the spring and early summer these hollows often become lakes of water, and every level spot is saturated.

to each out-building. Such a convenience might have saved life during the winter of 1872-'73 which was lost for want of it. In

An Enormous Arad — *Amorphophallus*.

The recent taste for "subtropical" gardening, in which regard is had to grace of form in plants or striking character of foliage, rather than beauty of flowers, has led to the introduction of numerous curious subjects, among which is *Amorphophallus Rivieri*. As it has not yet received any English name we can not offer any other as an alternative. Two years ago, Messrs. B. K. Bliss & Sons gave us a tuber about the size of one's fist as a great novelty just received from France. This tuber threw up a single leaf-stalk about two feet high, which at the top was surmounted by a large umbrella-like leaf cut into three principal divisions, which are themselves curiously and irregularly subdivided. An idea of the form of the leaf can be obtained from the engraving, though a portion of it is concealed by the flower. The tuber produces but one leaf each season, but this is a monster. Mr. Bliss informed us that he saw them in France, from strong tubers, four or five feet high, with the blade four feet across. Growing by itself upon the lawn, its unusual and somewhat grotesque appearance is sure to attract attention. The leaf stalk is of a greenish black color, with numerous lighter spots, while the leaf itself is of a dark green. Our tuber when taken up in the fall had increased considerably in size and thrown off a great number of offsets, by means of which it may be rapidly propagated. This spring Messrs. Olm Brothers, florists, of Newark, N. J., had a large tuber flower in one of their greenhouses; they sent it to us, and we have had an engraving made from it. The huge flower was, including stem, about three feet high; the flower stem arises from the tuber unaccompanied by leaves, and, as well as the flowering portion, is of a peculiarly lurid greenish purple color and spotted; the spathe or expanded portion is irregular in outline and somewhat ruffled on the margin; the interior surface has a somewhat metallic luster. The projecting central portion, the spadix, is flattened sidewise and roughened with small tubercles. It is at the base of this spadix that the flowers are borne; the large showy spathe being only a protecting covering and not the flower itself. The flowers are of the simplest structure, consisting for the male flower of a single anther and in the fertile flower of a single pistil, each without anything like calyx or corolla. The pistillate flowers are crowded together in a band around the base of the spadix, with the staminate ones in another band directly above them. The engraving will at once bring to mind the common Calla Lily, and the flower looks like an enormous lurid purple Calla without leaves, but still more like some of the exotic Arums. We ought not to take leave of this remarkable flower without saying something of its odor—to describe it is hardly possible. The eccentric Dr. De Wolf said that a dead dog was a true aristocrat, as he kept common people at a distance; so this must be among the most aristocratic of flowers, as but few would venture upon familiarities with it. Dr. Wight says of an Indian species, *A. campanulatum*, that its odor was such "as to induce flies to cover the club of the spadix with their eggs." The flies may be pardoned for their mistake if the odor of that species was like that of this. It is not a desirable plant for house culture, but a most

striking one upon the lawn, and as the flowers appear before the leaves they can be cut away before they open. As the tubers multiply rapidly, and are kept with no more care than is required by the Dahlia, we think it will

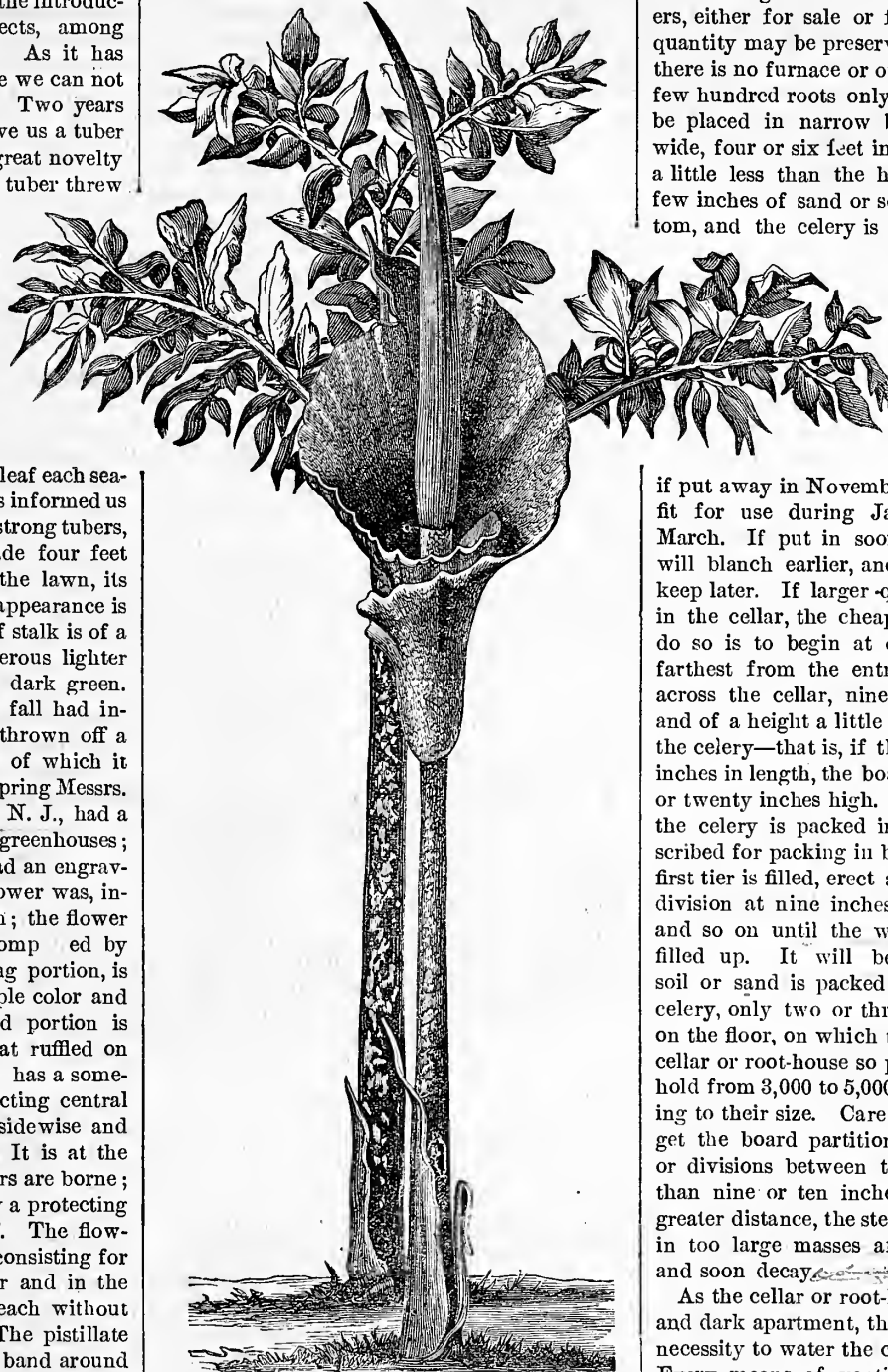

AMORPHOPHALLUS RIVIERI.

become popular with those who like odd things. The plant was first brought into notice by M. Riviere, director of a garden near Algiers, who found a minute tuber accidentally mixed with some seeds sent from Cochinchina, and to whom the species was dedicated. The generic name, *Amorphophallus*, might be translated, an unshapely club, probably because the club-like spadix is flattened and irregular in form.

The Preservation of Celery.

BY PETER HENDERSON.

Spring is hardly the proper season in which to describe an operation that can only be done on the approach of winter, but I am convinced that many of your readers would cultivate celery, were they sure that they could easily pre-

serve it during the winter. Market gardeners, who store away large quantities, preserve it in narrow trenches in the open ground, and protect it by means of a covering of leaves or litter, as already described in your pages and in "Gardening for Profit"; but for smaller growers, either for sale or for private use, quite a quantity may be preserved in any cellar where there is no furnace or other fire heat. When a few hundred roots only are to be stored, it can be placed in narrow boxes, say nine inches wide, four or six feet in length, and of a depth a little less than the height of the celery. A few inches of sand or soil is placed on the bottom, and the celery is packed in the box up-

right, the roots being placed on the sand at the bottom; the celery must be packed in as tight as possible, but without bruising. Boxes thus packed and stood on the cool floor of the cellar,

if put away in November, will be "blanched" fit for use during January, February, and March. If put in sooner than November, it will blanch earlier, and if stored later it will keep later. If larger quantities are to be kept in the cellar, the cheapest practicable way to do so is to begin at one side next the wall, farthest from the entrance, and erect boards across the cellar, nine inches from the wall, and of a height a little less than the length of the celery—that is, if the celery is twenty-four inches in length, the boarding may be eighteen or twenty inches high. In this narrow division the celery is packed in upright, as above described for packing in boxes. As soon as the first tier is filled, erect another board trench or division at nine inches distant from the first, and so on until the whole space required is filled up. It will be understood that no soil or sand is packed between the stalks of celery, only two or three inches being strewn on the floor, on which the roots are placed. A cellar or root-house so packed; 20 x 20 feet, will hold from 3,000 to 5,000 roots of celery, according to their size. Care must be taken not to get the board partitions forming the trenches, or divisions between the tiers of celery more than nine or ten inches apart, for if at much greater distance, the stems and leaves would be in too large masses and would generate heat and soon decay.

As the cellar or root-house is usually a damp and dark apartment, there will generally be no necessity to water the celery after it is packed. Every means of ventilation should be used, even in cold weather, for it must always be borne in mind that celery is a vegetable that will stand quite a severe frost without injury, so if the temperature of the cellar falls five or six degrees below the freezing point, no injury will be done. When celery or other vegetables are packed away for preservation in cellars or in the open field, it is indispensable that no water be allowed to lodge in the pit or trench; so that in the event of using a cellar or root-house for this purpose, a matter of first importance is to provide for thorough drainage, in soils where drainage is at all necessary.

THE WEEPING POPLAR is now being written up abroad, and this will probably convince our planters what we have for years insisted upon, that it is one of the most valuable of lawn trees. It should be grafted eight feet high.

THE PEA-WEEVIL.—We do not know if seed peas are unusually "buggy" or not this year, but we have had an unusual number of letters about the "pea-bug," as the insect is incorrectly called. One writer is afraid to plant some "buggy" peas for fear of introducing troublesome insects into his garden. So far as we are informed, the pea-weevil attacks the pea only. The mother weevil lays her eggs upon the outside of the young pod; she does not "sting" the peas, as many suppose. When the larva hatches out it eats its way to the inside of the pod and young pea, where it feeds on the (marrow) fat of the land, and, unless it is first eaten itself by pea-lovers, it forms a chrysalis within the shell of the pea, and in spring comes out as a small black beetle ready to continue the work. It is a general impression that because the germ is not injured "buggy" peas are just as good as any other for seed. This is a mistake, although the seed will germinate; the plants, being deprived of their proper nutriment when young, the weevil having devoured it, are never so vigorous and productive as those from sound peas. Our seedsmen have their seed peas grown in localities where the insect has not yet been introduced or where cultivators take pains to destroy it. Peas germinate when several years old, and if all in a neighborhood would agree to plant no infested seed for a year the insect would disappear. White says that putting the peas in a tightly corked bottle with a tea-spoonful of spirits of turpentine will kill the insects without hurting the peas. Others have successfully used chloroform in the same manner. If the peas are put into water the unsound ones will float. In raising peas for seed the insect can be avoided by planting in June, after it has ceased to operate, though in most localities late-planted peas do not succeed very well.

Notes from the Pines.

FORCED PLANTS.—Any plant made to grow and flower at other than its natural season is properly a forced one. When we bring Hyacinths and other spring-flowering bulbs into bloom in January, they are forced, though that is done so frequently and even in an ordinary window that we do not look upon it as forcing. There are many plants that we enjoy in the open border in spring that we can have in flower in the winter, if we take a little forethought, and get up the plants and pot them in the fall. I think I mentioned last year what gratifying success I had that winter in forcing *Astilbe* (or *Spiræa*, as some will call it) *Japonica* in my study windows. Bleeding Heart (*Dicentra*) is another excellent subject for forcing; it will do well in a warm window, and nothing can be finer. In forcing such plants as these the

ESSENTIAL THING TO OBSERVE is to give the plants a complete rest before we begin to start them. In the open border they are kept perfectly dormant by the low temperature, and when we pot them in the fall they should be kept in a cool place. The cellar is often so warm that they are excited into growth too soon, and this must be prevented by keeping them as dry as may be without injury. If kept wet in a warmish cellar, they will make a slow growth and fail of that absolute rest which seems to be necessary. Last fall the ground had begun to freeze before I had lifted all my plants, and some were grubbed up with a cake

of frozen earth adhering to them. These were put under the greenhouse bench to thaw out, so that they could be potted. Some weeks after, in overhauling the things stored under the benches, I came across some roots without a label, which on examination proved to be the Bleeding Hearts which were taken up to be forced but had been overlooked when the rest of the things were potted. They were so dry as to be apparently beyond all hope of recovery, and I was about to throw them out, but finally concluded to see what they would do, and potted them. I never saw the *Dicentra* finer than came from these roots, which had been so thoroughly rested that I supposed them to be past awakening.

A GREENHOUSE PUMP.—Early in the winter I got tired of the primitive way of dipping water from the cistern under the greenhouse floor and looked about for a pump. By good luck my eye caught the advertisement of the People's Pump, sold by W. S. Blunt, No. 77 Beekman street. An inspection of the pumps gave a favorable impression, and one was ordered and put in. It stands under the bench of the greenhouse, quite out of the way; the handle in use projects into the path, but at other times it is fastened up against the edge of the bench by a button, and is hardly noticeable. It can be transformed from a lifting into a forcing pump in "a jiffy," and as either it is perfectly satisfactory. The compactness of the affair and the ease with which it works are so satisfactory that it is almost worth while to build a greenhouse just for the fun of having a People's Pump.

It is not altogether satisfactory to write at the end of March notes to be read in May. Spring work has hardly begun, and in May one will not care to think about in-door plants. With so large and miscellaneous a collection as I have, it is a matter of interest, after cold weather is fairly over, to go about and see how things have passed the winter. It is a succession of surprises. Many plants that one would expect to find hardy are found dead, and others that were left to be killed by the winter will be found to survive. It is a great pity that we have nothing in this country to correspond to the French garden of *Acclimatation*. There is no direction in which experiments can be more usefully made than in testing the hardiness of different plants. It is true that the nativity of a plant is some guide, but by no means a certain one, as some of our persistent weeds are from tropical countries. We now and then find out by accident that a plant heretofore thought to belong only to the greenhouse is really hardy. Few persons can afford to experiment largely in this matter, and there should be some public garden where it could be done.

PRIMULA JAPONICA.—At last I have flowered this much talked of and high priced novelty. Year before last Mr. Hogg gave me a plant of the "simon pure" right from Japan, but it daily grew smaller. Last fall he gave me another, which was left out in a frame until January, and Mr. Chitty of Bellevue Nursery, Paterson, N. J., sent me this spring two more that had been similarly treated. One of these plants was put in the coolest part of the greenhouse and the other two in a window of my study, and all three came on finely. Many have complained of failure with this plant, but it has been due to too tender treatment. It is, no doubt, perfectly hardy—though no one that I have heard of has risked his \$3 or \$5 plants to establish the fact—and should be treated like

any other hardy perennial. If wanted in bloom in the house, then it should have the same treatment as other hardy plants that are forced. The plant is a beautiful one, but mine do not bear out the extravagant encomiums of the English horticultural journals or the highly colored plates of the foreign catalogues. It is handsome and showy, but has not afforded me so much pleasure as another Primrose.

PRIMULA INVOLUCRATA, about which no one has exhausted all the adjectives and exclamation points. A plant of this modest species came from Mr. George Such, at South Amboy. The leaves are of a peculiar silvery whiteness, and the plant would be a handsome one if it did not flower. It throws up a cluster of long tubular, delicate yellow flowers of the fragrance of a spring morning.

PLANTING TIMBER.—It will be but a very few years before timber becomes very much enhanced in value. Ten years more will see the supply in the north-west greatly reduced in quantity. No more profitable use of land can be made than to plant walnut, chestnut, oak, hickory, spruce, ash, maple, poplar, and other trees that have a value in the arts for their timber. It is highly probable that, as pine becomes more costly, it will be used only as joists, rafters, and flooring, and that brick and stone will be more commonly employed as building materials. When this occurs the stock of pine, throughout the country, will be found to last almost indefinitely. The more valuable pine trees grow very slowly and would hardly be profitable to plant.

Crossing—Hybridizing.

There would appear to be just now an unusual interest in the matter of improving plants by crossing or hybridizing, to judge from the letters we have had asking us to describe the process. Crossing and hybridizing are terms often and incorrectly used to express the same thing. Crossing takes place between varieties of the same species, while hybridizing should only be applied to the operation as applied to plants of different species. The latter are very often infertile and can not be propagated by seed. We are asked for directions to perform the operation, but can only give the most general ones. Whoever would experiment in this matter must have some knowledge of the structure of flowers and be a close observer. The production of a cross or a hybrid is effected by fertilizing the pistil of one plant by the pollen of another plant. To understand this simple statement requires a knowledge of flower structure that many have never acquired. In every perfect flower there are two sets of organs engaged in the production of the seed. A magnified flower of the grape (fig. 1) will serve to illustrate. The bottle-shaped central body, *b*, is the pistil which contains some minute greenish pulpy bodies which may become seeds, but which will never mature into seeds unless they receive some influence from without; in other words, they must be *fertilized*. Here in the grape there is an abundant provision for fertilizing the pistil in the bodies which surround it, one of which is marked *a*. These are the stamens, each of which consists of a two lobed pouch upon a stalk. This pouch is the anther and the stalk the filament. When the flower is fully developed, each half of the pouch or anther cracks open by a slit and lets

out a fine yellow dust, the pollen. Unless this pollen, or that of some other grape, falls upon the proper part of the pistil, which in this case is the flattened disk at the top, it will produce no seeds. It is not necessary here to state what is known of the way in which fertilization takes place. Practically there must be a pistil to be fertilized and pollen to fertilize it. In the grape these are both provided in the same flower; in Indian corn, the squash, and all of that family, one set of flowers has the pistils and another set the stamens which furnish the pollen. In the hop, spinach, and others, the pistil bearing and pollen producing flowers are on different plants. The grape was taken as an illustration, and let us continue with that. In the ordinary course of things the pollen will fall upon the stigma and fertilize it, or if the pollen of this flower is not quite ready to be scattered and the pistil is ready to receive it, the pollen from another flower close by may fall upon the pistil and complete the work. Now to cross this grape, which we will assume to be the Clinton, with another, we will say the Black Hamburg, we have to attend to three things: We must prevent this flower

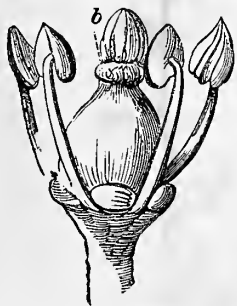

Fig. 1.—GRAPE.

from being fertilized by its own pollen; we must bring to it the pollen of the Black Hamburg and, after applying this, prevent any pollen from another Clinton flower being brought by winds or insects to this pistil. The petals of a grape flower fall off as a little cap; when this is about to fall off it is removed, and all the stamens, before they have shed their pollen, are cut away. Some are so expert as to be able to pinch them off. This prevents the flower from fertilizing itself, and is done early in the morning. In practice several flowers on a bunch are prepared and all the rest cut off. The pollen of the Black Hamburg must be at hand. This is collected from the flowers of that variety by holding a sheet of paper under the flower clusters and shaking them. When the day is warm and the air dry, pollen in great abundance is shed by the anthers. The pollen when collected is carefully preserved in a small bottle or, if not to be kept long, in a paper. Grape pollen will keep in good condition for some weeks, and that of other plants

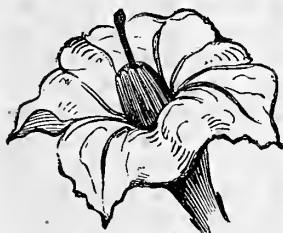

Fig. 2.—POTATO.

has been known to preserve its vitality for months. The maturity of the pistil is known in the grape by the moist appearance of the stigma, as that portion which receives the pollen is called; and by means of a camel's hair brush some of the foreign pollen is placed upon the stigma, and then the flowers that have been thus operated upon are inclosed in a muslin bag to prevent insects from bringing other pollen to them, as this might interfere with the action of that already applied. This is the briefest outline of the manner of crossing or hybridizing the grape. If a novice wishes to try the process upon some other plant, the first difficulty he will meet with is that the flower is quite different in appearance from

the grape, and he is at loss to discover the parts that appeared so plain in the grape flower. All flowers are constructed upon the same plan, but the variations in carrying out the details are truly wonderful, and unless one knows the variations of which all the parts are susceptible he will be puzzled. Compare the potato flower, fig. 2, with the grape flower.

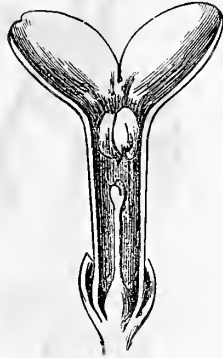

Fig. 3.—LILAC.

In the grape the stamens are longer than the pistil, and stand out from it, and the filaments are long in comparison with the anthers. In the potato the stamens are shorter than the pistil, and are crowded close to it; the anthers, which in the grape were small, are here longer than the filaments, and instead of opening by a slit to let out the pollen it makes its escape through little holes in their tops. Here are all the parts that are in the grape flower, but wonderfully modified. Another variation is all we can show. Fig. 3 is a lilac flower cut open. Here the novice will be puzzled to find two stamens only, and these stuck fast to the tube of the corolla. A mere outline of the matter can only be given here, but enough has been said to show that whoever would undertake artificial fertilization must give some thought to the matter. The whole subject of natural fertilization is full of interest and abounds in curious facts, and is worthy the study of any intelligent person, even if he does not wish to make any practical use of the insight he may gain of the workings of nature. It may be mentioned here that a French florist, whose name we have forgotten, has recently found it to be a great aid in his fertilizing operations to touch the stigma of the pistil with honey, and that by thus doing his success is much more uniform than before. It is probable that the honey serves to retain the pollen until the stigma is ready to receive its influence.

The Vanilla Plant.

BY H. G. LUNGREN, M.D.

[By Vanilla plant we do not refer to the plant which furnishes vanilla, but to a native species, *Liatris odoratissima*, which, on account of a similarity of odor, has received that name. Most of the species of *Liatris* or Button-snakeroot, have a tuber-like root, and long straight stems upon which the numerous flower-heads are crowded in a close spike. A number of these are cultivated as ornamental plants, and we figured several of them a few years ago. In *L. odoratissima*, the root-leaves are from 8 to 12 inches long by 2 or 3 broad; those of the stem very small. The stem divides above into a broad branching panicle of purple flowers, which make the plant an attractive one. Our correspondent, Doctor H. G. Lungren, of Volusia Co., Fla., has at our request given us the following account of the plant.—Ed.]

The Wild Vanilla, or, as it is commonly called, "Heard's Tongue," or "Deer Tongue," grows abundantly on the edges of what are called "Bays," *i. e.*, low mucky places in the pine woods, which are partially covered with water and grown over with bays (a species of *Magnolia*), or on low swampy pine woods in

East and South Florida and in portions of lower Georgia. The fresh leaf has, when crushed, a greenish, disagreeable odor, but when pulled from the plant and dried in the shade for a day or so, it becomes highly fragrant, having a smell resembling vanilla or Tonka-bean, and similar to the sweet-scented vernal grass, but much stronger. This odor is developed by some chemical change made in the leaf during the process of drying, whereby a peculiar principle known as Coumarine is formed. Coumarine is found abundantly in the Tonka-bean of commerce, but so abundant is it in the *Liatris*, that it is often found in large quantities on the upper portions of a mass of the semi-dried leaves. It is readily sublimed by a low degree of heat (150°), and the heat generated in these masses or bundles is sufficient to sublime it on the upper or cooler layer. When found in this way, Coumarine is composed of snow-white, needle-shaped crystals, exceedingly fragrant—a leaf of the *Liatris* often being covered on its under side, and looking as though it had been out all night in cold, frosty weather.

The dried leaves furnish an article of commerce, and one that is steadily growing in importance. It is gathered all through East and South Florida, principally on the St. John's river and its tributaries, by the poorer people, and sold by them in small lots to the country store-keeper in exchange for goods; by these store-keepers it is sent to the balers and packers, by whom it is sent to New York for home use and exportation. Pilatka, on the St. John's river, is the head-quarters in this trade. One may often see seventy-five or one hundred bales, of 200 lbs. each, lying on the wharves, awaiting shipment—once dealer at this place having an order to fill of 150,000 lbs. Adults can gather from 150 to 400 lbs. of the green leaves in a day; active boys and girls nearly as much. The green leaves are taken home and dried in the shade, and lose about 80 or 85 per cent; they are, when dried, sold at the country stores for from 3 to 6 cents per lb., yielding quite a good return for the labor. The packer bales and ships, and realizes from 8 to 12½ cts. per lb. The dried leaves are used to give a flavor to segars, snuff, and smoking tobacco. For segars, it is sufficient to place the leaves and segars in alternate layers in a box, and allow the whole to remain together for several days; for snuff, the leaves are dried, ground, and mixed; it is granulated or shredded up and mixed with smoking tobacco. A small quantity is sufficient to flavor a large mass of tobacco. The odor is given off much more intensely on a damp day than on a dry one. Although large quantities of these leaves are consumed in our home factories, a much larger quantity is shipped to Germany and France direct, where it is rapidly growing in favor. It is quite probable that it will soon be an article used extensively in perfumery; and as it is known to keep "the wicked moth away," it will be in great demand for that purpose in the stead of the strong-smelling camphor and tobacco stems.

The Pale Corydalis.

As we were, a few years ago, inspecting the grounds of a well-known amateur cultivator of flowers, he said: "Come and see a new *Dicentra* that I have just flowered." We went, and found the Pale Corydalis, *Corydalis glauca*, which we had never before seen in cultivation

except in our own grounds. Among the many wild flowers that we have introduced into the garden none have given us more pleasure than this. It is a biennial, which ripens its seeds

Fumitory Family (*Fumariaceæ*), and its name is the ancient Greek one for Fumitory. The beautiful Alleghany-vine, *Adlumia*, and the native and cultivated Dicentras (Bleeding-

Georgia by the late Mr. Durand, without suspecting it was not a wild plant. He sent the plant to Torrey and Gray, who supposed it to be a new species of Cinquefoil or *Potentilla*, and



PALE CORYDALIS.—(*Corydalis glauca*.)



VANILLA PLANT.—(*Liatris odoratissima*.)—See page 183.

and drops them early, and the young plants from them acquire sufficient size the same season to flower next year. In the wild state it is more common in rocky places than elsewhere, and is often not more than six inches high, but in the more favorable soil of the garden it is two feet or more. The plant in its first season from the seed is not without beauty, as it presents a tuft of finely-divided leaves which are of a remarkably pale, glaucous green color. In May it shoots up a leafy flower stem which bears at the top a panicle of purplish, yellow-tipped flowers, which, while not very showy, are exceedingly neat and pleasing. In the garden the plant continues to flower nearly all summer. The flowers resemble those of the well-known *Dicentra*, except that instead of having two spurs to the corolla this has but one. This species is rather common, and is found as far south as the mountains of North Carolina; a pale yellow species, *C. flavula*, and a golden yellow one, *C. aurea*, are less common. Several exotic species are perennials, the finest of which, *C. nobilis*, is sometimes, though rarely, seen in our gardens. The *Corydalis* belongs to the

Heart, Dutchman's Breeches, and Squirrel Corn) also belong to the same botanical family.

The Indian Strawberry.

It is a little strange that a plant, at first known only from Nepaul, should have become

named it in their Flora of N. A., *P. Durandii*. As these botanists had the plant without fruit, this mistake is not to be wondered at, as this *Fragaria* differs from all other strawberries in having yellow flowers, which is the color of the flowers in most *Potentillas*; the main differences between the two being found in the fruit. The Indian strawberry, which is a much smaller plant than either of our native ones, unlike them produces leaves along its runners; its manner of flowering is different from that of other strawberries in producing a single flower stalk in the axil of a leaf which bears but a solitary flower. The calyx proper has acute sepals, and immediately beneath these are toothed leafy bractlets; petals bright yellow. The fruit, which is small, has the appearance of an ordinary strawberry, but is odorless and insipid. In Europe it is valued as a plant for growing upon rock-work; it is also fine for a hanging basket, being an almost perpetual bloomer. A piece of our garden plant was taken into the house, and has produced its cheerful yellow flowers and bright but deceptive scarlet strawberries all winter.

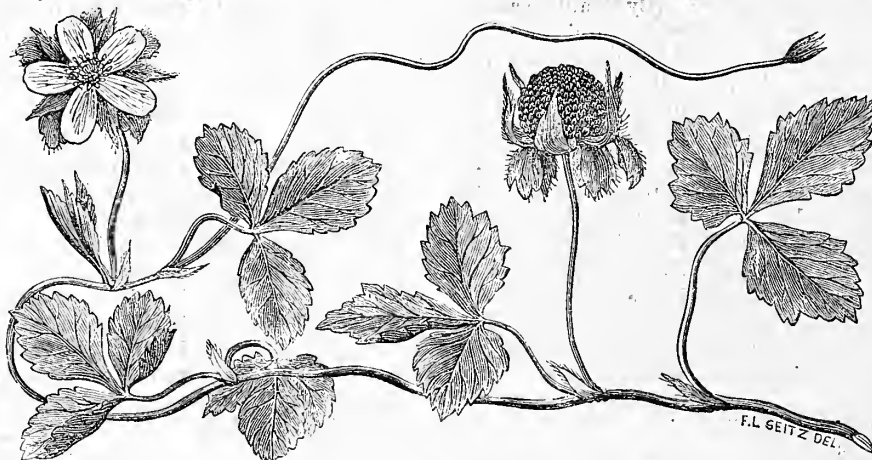

INDIAN STRAWBERRY.—(*Fragaria Indica*.)

naturalized in this country and make itself at home with all the appearance of belonging here. This the Indian Strawberry, *Fragaria Indica*, has done. It is sparingly found near Philadelphia and more plentifully farther south. Many years ago it was collected in

THE HOUSEHOLD.

(For other Household Items, see "Basket" pages.)

About Paper-Hangings.

It has no doubt puzzled many housekeepers that wall-paper should be called paper-hangings, and

there had to be as many blocks as there were to be colors in the figure, each color being applied separately, and the paper dried after each impression. For the finest French papers block printing is still in use, and at one establishment celebrated for its papers, which are said to equal fine paintings, as many as 3,000 blocks are required for one pattern. The invention of the paper machine, which pro-

it body. The first operation, as in block printing, is to apply the ground color, which, like all other steps of the process, is done by a machine (fig. 1); here one side of the paper which is in large rolls of 60 to 100 pounds comes in contact with the body color, and is passed into the drying-room (fig. 2), where it hangs over poles in a highly heated atmosphere until it is quite dry. It is again

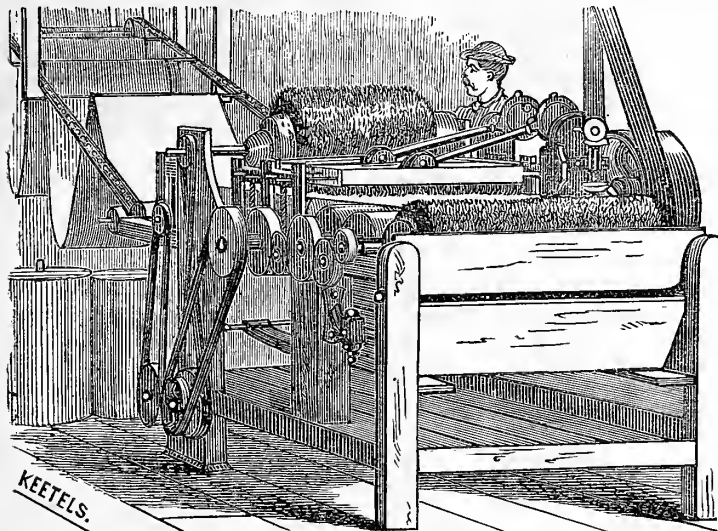

Fig. 1.—"GROUNDING" THE PAPER.

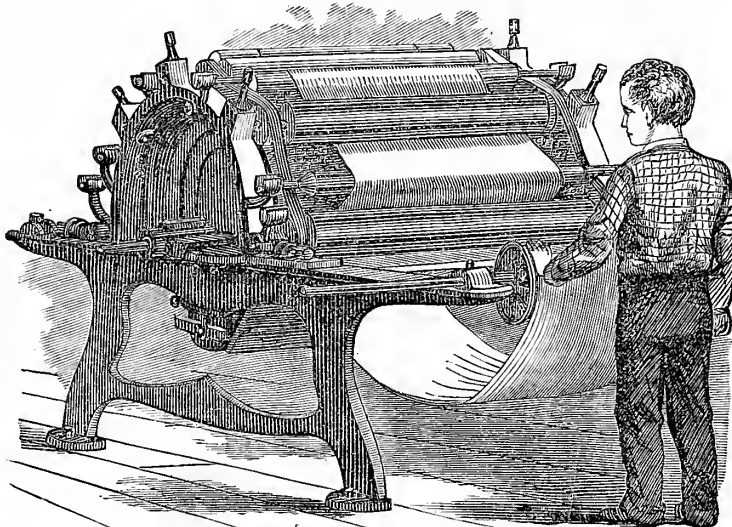

Fig. 3.—"SATINING" THE PAPER.

that a man whose business it is to paste paper upon a wall should be called a paper-hanger. In olden times the rooms of the wealthy had their walls covered with fabric of some kind—silk or velvet and even leather being used, as well as tapestry, which was often most elaborately embroidered and very costly. These were called hangings. Some 200 years or more ago paper to use instead of these fabrics was imported into England from China, and was naturally enough called paper-hangings. Paper for walls had been in use from time immemorial in China, where the designs were put upon the paper with a brush. The early English attempts to imitate the Chinese paper were by stencilling—i. e., rubbing on the colors through patterns cut out of pasteboard. This rude method soon gave way to stamping the figures upon the paper by means of wooden blocks upon which the design was carved. Before the invention of the paper-making machine the paper was all in single sheets, which were first printed and then pasted together. First there was a ground

duces paper in a continuous sheet of any required length, and the application of machinery to the printing, has quite revolutionized the manner of

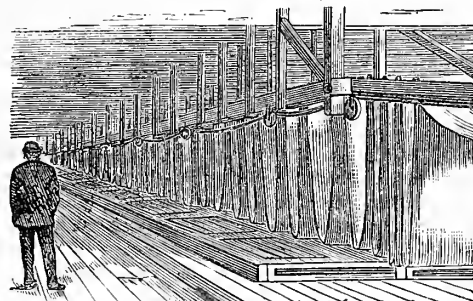

Fig. 2.—THE DRYING-ROOM.

making all but the most costly kinds of wall-paper. Calicoes were formerly all printed by hand with blocks as described for paper printing, and the invention of the calico-printing machine naturally

rolled up for the next process. If the paper is to be "satinéd," as those which have a smooth, polished surface are called, it is passed through a machine (fig. 3) where it is subjected to the friction of a rapidly revolving brush, which leaves the surface finely polished. The paper, whether "satinéd" or with a rough ground, has the figure printed on it by means of a machine (fig. 4) very much like those on which calico is printed. The designs are cut upon rolls, which are cylinders, usually of copper, upon which the pattern is engraved. These are so arranged as to take up the color and apply it to the paper as it passes over them. There must, of course, be as many rolls as there are colors to the figure, and the impression made by each must match that made by the preceding one with great nicety. The final operation is to make up the paper from the large roll into smaller ones such as are sold in the stores. This is also done by a machine (fig. 5). When the small roll is of the proper size it is cut off by means of a large knife with an edge like a saw. Those pa-

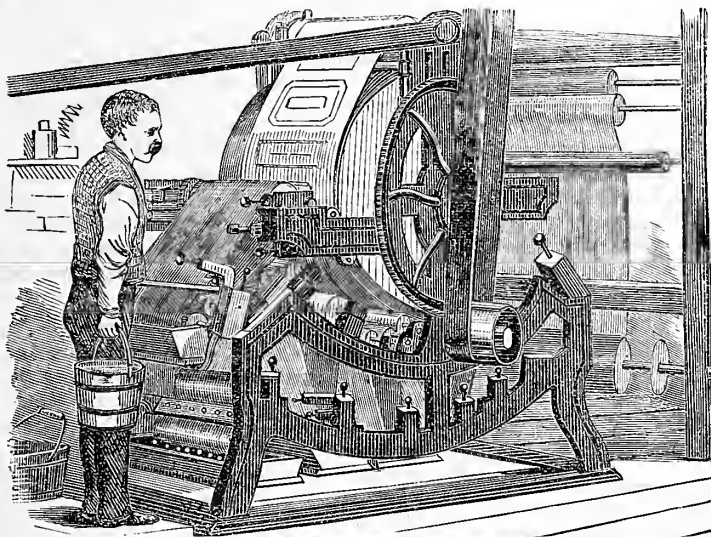

Fig. 4.—PRINTING THE PAPER.



Fig. 5.—MAKING UP THE ROLLS.

color rubbed evenly over the paper by means of brushes made for the purpose; this was dried, and either printed on directly or the surface polished by rubbing. Then the design was printed on by blocks, first dipped in the color, and then applied by means of pressure or struck a smart blow with a mallet. One block printed but one color, and

led to the use of a similar one for printing paper. One of our artists has recently visited a paper-hanging factory, and made sketches of the operations. The colors used are mixed with a size of glue-water sufficiently strong to make them adhere when dry, and some, especially the ground color of the paper, are thickened with very fine clay to give

pers that present a rich, velvety surface have this effect produced by what is called flock—this is wool, usually the shearings from woolen-cloth factories, dyed of different colors, ground in a mill, and sifted. The portion of the paper to which the flock is to be applied is first covered with an adhesive size and the flock sifted over it. Frequently

papers have gold introduced in the pattern. The places to be gilded are printed with size, and gold-leaf imitation metal leaf is applied by hand.

Closets in the House.

Having suffered some for closet room at one time and another, or for places to stow away things, I have had considerable sympathy with that man who said that when he built a house he should begin with a big closet and make additions to that. When I speak of closets my husband understands me, but immediately begins to talk about modes of ventilating closets, and I have only gradually grown to understand his strong sense of the necessity for closet ventilation. Having for several years hung the clothing of the family in rooms where there was a free circulation of air, I am surprised when I go into the well-finished clothes-rooms (let us call them *close* rooms) in some fine houses to find how dead and unwholesome—not to say foul—the air is. The soiled garments hung in a tight and dark room, contaminate the whole apartment, and such contamination is very perceptible to a well-trained nose or to olfactories accustomed to the refinement of habitual pure air. Old boots and shoes cause a bad smell in a close room.

To pursue an unpleasant subject a little farther—why *will* people keep the dirty clothes designed for the weekly wash in a close closet? That which has come from the skins of unclean or unhealthy persons (the latter adjective describes nine tenths of the human family) grows constantly more impure shut away from light and air, and everything kept in the same room is contaminated by the effluvia. Can not soiled garments be kept while waiting for the wash, in some bag or covered basket in the wood-shed or some such place? There are baskets on purpose for soiled clothing, open enough for ventilation but too fine to admit mice.

Unless a closet is ventilated so that there is some circulation of air through it, it is no place to hang away night-gowns, unless they have previously been aired, so that the perspiration accumulated in the previous night—only insensible perspiration, perhaps—has been dried and sunned away.

I have no means of ascertaining this morning how far science has attended to this subject of closet ventilation, but I am very sure that it is an important matter, and should be well looked into. Of course, there can be closets with windows in them, and this should generally be the case. They can be kept dark, as a general rule, if desired, but it ought to be possible to admit a flood of light.

Closets built under stairways might be ventilated by a grate closed by a sliding shutter under one of the stairs. It would be well to have the grate capable of being shut to keep out dust when the stairs are swept. I do not know whether this has been tried, but the idea has occurred to me as practicable. A sliding window in the closet door is also possible. The small sliding window in the door and the grate in the elevation of one of the stairs ought to give a sufficient circulation of air to a small stairway closet.

It is idle to suppose that a closet (or any other room) is provided with ventilation because it is built large and high. There must be some circulation of air, or the atmosphere becomes dead.

RELL.

Home Topics.

BY FAITH ROCHESTER.

TOWNS-PEOPLE'S CRITICISMS ON COUNTRY FARE.—The tide will soon be setting again from city to country. City people are generally ready to pay country people a good price for comfortable lodgings and board during the hot summer months; but they make many complaints of disappointment in respect to the fare which they are obliged to take up with along with rural life among the farmers.

I have had several months of city life lately, but the country seems likely to become my permanent home, and that speedily—whereof I am glad. So I may speak freely of the shortcomings of country

housekeepers and householders, as one who may be included somehow in the general castigation.

A friend writes to me in a private letter: "I do think that there is a deal of missionary work to be done among farmers' wives. I was sometimes vexed with the family where I boarded to see how every drop of cream was converted into butter and heavy lard pie-crust set before us; while cracked wheat, graham meal, and oatmeal were unheard of. I felt like exclaiming that 'good farmer's fare' was the most indigestible in the world. The inevitable *pig* occupies so prominent a place in their household economy that I was tempted to wish that a hog-plague would sweep through the country."

So large a proportion of those who flee from the city during summer are in pursuit of healthier conditions of living that it seems as though it would be the fair and Christian course for us who have any of them to entertain to give some study to the subject of the preservation of health by natural means. First the air. There is plenty of pure, life-giving oxygen out-of-doors, but the air of many country houses is constantly foul and poisonous. I say that which I do know. The windows are opened to ventilate the dwelling, perhaps; but ignorance has done its best in many cases to make a supply of pure air in-doors, even in the breezy summer time, literally impossible until great changes are effected. On one side there is perhaps a big horse barn and cattle shed, with piles of fermenting manure. On another side is a row of foul pig-pens; on another the slops from the kitchen and pantry are thrown out to decay and ferment and send up their fetid gases; under the floor of the dwelling is the unclean cellar perhaps, where very likely there is no such provision for ventilation as allows a fresh breeze to sweep through it, and where, possibly, some of last year's vegetables are going to decay. Then there is perhaps an open, unshaded "out-house," neglected and disgusting. So it seems hardly possible for the dear, good winds of heaven to blow toward the house from any quarter without bringing deadly poison along with them. There is no disagreement among scientific men, including all educated physicians, as to the fact of the poisonous nature of all these foul odors that arise from decaying animal and vegetable matter.

Do you ask what shall be done with refuse matter? Our wise Creator is trying to teach us the folly of all waste, and that everything is good in its place. The manure from which the early Dutch farmers of New York used to move their barns away and leave behind as useless, is now prized and cared for as of great value to make the land give forth its crops. We can not longer afford the deep vaults as receptacles of human excrement; we can not afford to pollute our rivers of water with it by means of sewers. A little pulverized dry earth scattered in mercy over each addition to this kind of "refuse" or "waste" matter turns all its apparent foulness into treasure for the farmer, fruit-grower, and florist. The kitchen slops poured into a compost heap and properly worked and mixed with soil save the premises from evil and yield their blessing to the garden and the field.

DIFFICULTY WITH GRAHAM GEMS.—Ought I to "fuss" a little? Well, do you know?—I *couldn't* make a graham gem fit to eat for weeks and weeks last summer! Actually, I got to thinking that graham gems must be a humbug, for I tried every way, and nobody would eat my gems if they could get any other bread. I did not hanker for them myself.

There came an article in *HEARTH AND HOME*, beginning with the question: "Did anybody ever see any of those wonderful graham gems, made only of flour and water, which are said to be perfectly light and sweet, 'perfect puffs,' etc.?" This article harmonized with the mood into which I had fallen, and despite all my happy experience of years gone by, I began to read it aloud in a triumphant tone to my husband, who had not ceased to sigh for "good graham gems."

I looked up after reading a little way, and met such a look of astonishment (at my tone and man-

ner I suppose) that I laid down the paper to hear the grave remark: "But we have had graham gems made only with flour and water that were deliciously sweet, perfectly light, and sufficiently tender, and you have made them many a time."

So I had. I was sure of it at that moment. I remembered how I had time and again myself broken open a fresh gem (by the way, they should always be broken and never cut open when warm—the same of all warm bread) with the remark, "Now, if that is not light, I don't see how bread can be light"—alluding to a positive declaration made by one of the wise men of the deceased "Farmers' Club" that unleavened graham bread "could not be made light."

Well, I tried again, asking first to have the stove-pipe lengthened above the roof of the woodshed or summer kitchen where it stood. I had to wait a long time for the oven to get decidedly hot, and Pater had almost finished his breakfast before I could give him a hot gem; but that morning the gems were a success—for the first time in more than three months. We had lovely white yeast bread upon the table that morning, made of the "gilt-edged" or patent flour—exquisitely white, but said to contain a large proportion of the nutritious canaille or middlings. (Will the "humbug man" of the *Agriculturist* please inform us whether this "patent flour" could be classed under the head of "sundry humbugs.") Every one at the table preferred the gems to the much beloved white bread, and that day baby called only for "good gem" when she was hungry for dinner or supper.

The great mistake that I had been making all that time was in not having my oven hot enough when the gems were put into it. The chief secret of making "perfect puffs" lies in having the oven so hot that a skin or crust is very quickly formed, and this confines the expanding air and water as the inside of the gem grows hot, so that the gem comes out of the oven, if the batter has been well stirred and well baked, all full of fine air-holes.

A great many people can not believe that these simple flour and water gems can be really as good as those mixed with sour milk and soda, or with baking-powder, and salted and sweetened. I tried them with baking-powder and sugar, and with yeast, butter, and sugar, but we all do honestly prefer the genuine flour and water gems now that I have regained the secret of making them. New milk is better than water for mixing if you can get it. I have been no more pleased than surprised to find that my children, having grown accustomed to forms of food that were sweet, because they had not been deprived of the natural sweetness of their materials in the processes of preparation for the table, prefer these simply cooked and plainly seasoned dishes to what is called richer food.

It takes a careful cook, who understands the science somewhat, to make plain food palatable. If Bridget leaves the sugar out of your gems or johnny-cake she will probably try to atone for its absence by an extra allowance of salt—something to give the bread a taste you know! As though God forgot that when he contrived the wonderful wheat kernel! But it requires a refined taste, perhaps, to appreciate the peculiar sweetness and delicate flavor of well-cooked wheat.

Chocolate Cake.—Mrs. E. G. B.—Butter, $\frac{1}{2}$ tea-cupful; sugar, 2 tea-cupfuls; flour, 3 tea-cupfuls; milk, 1 tea-cupful; eggs, 4; baking-powder, 1 tea-spoonful. Bake as jelly cake, and put between the layers the following mixture: Into one pint of boiling milk stir one tea-cupful each of grated chocolate and sugar and one table-spoonful of corn-starch. Boil until it forms a smooth paste. In boiling milk, always set the pan with the milk into another vessel containing water, and thus remove all danger of burning.

Corn-Starch Cake.—Mrs. E. G. B.—Sugar, $1\frac{1}{2}$ tea-cupful; flour, $1\frac{1}{2}$ tea-cupful; butter, $\frac{1}{2}$ tea-cupful; corn-starch, $\frac{1}{2}$ tea-cupful; milk, $\frac{1}{2}$ tea-cupful; six eggs, whites only; baking-powder, 1 tea-spoonful. Flavor to taste.

BOYS & GIRLS' COLUMNS.

The Doctor's Talks.

Do you recollect that Mother Goose verse,
Mary, Mary, quite contrary,
How does your garden grow?

It is not the finest specimen of a rhyme, as to make it rhyme properly you have to say *con-trary*, which is contrary to the rules of pronunciation. Perhaps instead of asking Mary, or any other youngster, boy or girl, how her or his garden grows, I had better find out if she or he has a garden. Have you a garden? If not, go to work right off and make one. You will think that a very difficult thing to do, especially those girls and boys who live in towns and villages where land, one of the very first things one needs in making a garden, is very scarce. The word garden covers a wide range, as a garden may be of many acres, only a few feet of a back-yard, or an old soap or similar box filled with earth. In fact, it often happens that the one who has the smallest of these gardens finds more enjoyment in it than those who have very large ones. "Enjoyment" is just what I wish you to have a garden for, and I hope that every boy and girl old enough to read this will this summer have a garden, if it is only just one plant, and that a bean or one of the very commonest seeds. If any of you have never put seeds in the ground and seen plants grow, here is something you can do that will give you pleasure all summer long. Not pleasure only, but you can learn much from a garden, even if it is only a very little one in a box or a pot. The crackling sound when you stroke the cat's back on a cold, dry day in winter is only thunder on a very small scale; the little snaps are from the same cause which follow the same laws as that which makes the stunning thunder-clap. A twenty-acre field of wheat is made up of single wheat plants, and if you sow a single wheat grain and watch it from the seed until the plant that comes from it ripens wheat again, you can learn as much about the way in which wheat grows as if you had a large field to observe. Indeed, you would be likely to learn more, as having but one plant to watch you would have a better chance to see what it was doing than if it were crowded by others. If you can get a small bed in the large garden of your parents that will be very pleasant; but if this not convenient you may be able to find a little spot in some fence-corner somewhere. Those who live on a farm will usually be able to do one or the other of these. Those who can not get a bit of earth in any other way can have a box in some safe place, only a box of earth will often need watering in hot weather. Having the earth, it must be made light and fine by digging and raking, and then it will be ready for the seeds.—

"What seeds shall I sow?" you will ask next; and my answer will be, What you can get. If your mother finds that you wish to have a little garden, you may take my word for it that she will be very glad to help you, and if she has no flower seeds there are no doubt some friends who have will be willing to let you have some. I have noticed that persons who are really fond of flowers are not only willing, but glad to help others who love them. If there are no flower seeds, then take some beans, or squash, or any garden or field plant. Only have something that will grow, and that you can watch from day to day. Don't put your seeds too deep, nor too thick. Small seeds need but very little earth as a covering, and no plants do well when they are crowded. You must ask some older person to tell you how the seeds ought to be sown. A seed—did you ever see anything more wonderful? A little, dry, lifeless body that has been lying still for months, it may be for years. You put it in the ground, and what a wonderful change! A living plant comes from it, that will grow often many feet in length. I don't mean to say that the plant was in the seed, but the beginning of it was—a tiny, baby plant, so to speak, all wrapped up, very much asleep, you will think, to have kept quiet so long, and with enough food with it to keep it growing until it is strong enough and quite ready to run alone. Suppose that all plants had heretofore grown from cuttings or slips of other plants, just as you know some do, and some one should come along with a bag of seed, we will say tomato seed, and declare that each one of these little yellowish things, no bigger than a flattened out pin's head, would produce a large plant that would bear a bushel of fruit, who would believe him? Why, each single seed would be a greater wonder than Barnum's "Great Moral Show." But, oh dear! God's wonders are so manifold, that we all of us, old and young, have our senses confused by their very abundance. As with the seed, the whole of a plant's life is full of wonders, and if you watch your plants carefully you will see every day some new thing. If you have Morning Glories or other climbing plants, just see how they get hold of something to lift up their weak stems; if they twine, like a Morning Glory, just try to make one of them twine in the opposite way, and see

what success you will have. Each leaf as it appears will be a thing of beauty, and then there will be flowers, bright delicate flowers for you to admire. But before the flowers open there will be something to see that is quite as interesting as anything else about them. You must notice, with the single flowers at least, how nicely the parts are packed away in the bud. The parts of the flower are not stowed away all in "a muss," but each as carefully folded as your mother folds her choicest linen. Just see how nicely the Morning-Glory is packed, and how prettily it is twisted, and compare this with the way in which the flower of the Four-o'clock and others are tucked in. Then, as flowers go, seeds will begin to ripen. You will notice that the seeds are in pods or cases of different shapes, and that some of them when ripe open to let the seeds out. The different ways of doing this will bear watching, and if you wish to save any seeds yourself you must learn which plants scatter their seeds naturally and which do not. But I can not tell you all that there is to see in your garden, no matter how small it may be. You have eyes—learn to use them.

THE DOCTOR.

Another Currant Question.

In February last I, the Doctor, answered a little girl's question, who wished to know what the dried currants of the stores were. Now it is Miss Amy, down in Nova Scotia, who wishes to know why our garden currants, which do not come from Corinth at all, are called currants. Don't I wish I could tell her! It is probably because of a resemblance of the two in size and shape (when the store currants are fresh), but I am not sure. I can not find in my library any book that tells when and why the name was given. My oldest book about plants is dated 1640, and they were called *currans* then; but the author says that in some parts of England the currant is called *gozel*, which sounds like an Anglo-Saxon name. If we wished to know why the early inhabitants of Britain called the fruit "gozel" we should be equally puzzled. The study of names is a very interesting one, and I like to see young people wish to know all they can about them. We can learn much about the origin of names, but however far back a name may be traced, there is a point beyond which we can not go. We can learn that most of the words we now use were originally Anglo-Saxon, or from the Latin, French, and other languages, but why the names in these languages were given to particular things is not so easy to discover. The use of sounds to signify things began long before these sounds were expressed in writing, and the early history of language is very obscure. I hope the Nova Scotia Miss will get a more satisfactory answer to her next question, and should she find out anything more about this one I hope she will let us all know.

Aunt Sue's Puzzle-Box.

ANAGRAMS.

- | | |
|---------------------|---------------------|
| 1. Farce hunter. | 5. Buy oval car. |
| 2. La! "monkies." | 7. I'm in coal-pit. |
| 3. I go, Miss Mat. | 8. Rebel's aguc. |
| 4. Can not live on. | 9. Aunt, oil dice. |
| 5. Secure tin. | 10. Our thought. |

SYNOPATION.

Syncopate a substantive and leave a verb; syncopate the verb and leave another; syncopate that and leave a proposition; syncopate that and leave a beverage.

JESSIE MAY FLOWER.

CROSS-WORDS.

- My first is in hot but not in burn.
My next is in cream but not in chnrrn.
My third is in new but not in old.
My fourth is in snow but not in cold.
My fifth is in hair but not in curl.
My sixth is in peach but not in pear.
My whole is the name of a little girl.
C. E. GORTON.
- My first is in cord but not in twinc.
My next is in groan but not in whine.
My third is in Tom but not in Bill.
My fourth is in valley but not in hill.
My fifth is in Nell but not in Sue.
My sixth is in brown but not in bine.
My seventh is in good but not in bad.
My eighth is in you but not in lad.
My ninth is in square but not in round.
My whole in a library should be found.
LIZZIE B.

PI.

"Het nows-stirfd, chihw vaeh nail os gohn,
Gintnahu het dendhi konos,
Keil lyguti htsogs evah lipcdps wyaa,
Seunen, tino het korobs."

WILLIAM P. ALBRIGHT.

CONCEALED GEOGRAPHICAL NAMES.

- Oh I do not leave me, as I am all alone!
- Alas! Kate, my darling, I must go.
- Pa ran a horse all the way to the Saint Francis.
- When he returned from the San Franc, I scolded him so that he begged for mercy.
- Although he said, "Oh I ought to have known better."

C. W. SUELMIRE.

SQUARE-WORDS.

Square the words "LOVE" and "HATE."

CHARLEY SMITH.

ALPHABETICAL ARITHMETIC.

W K I) D I O C Y B (K K I E
E D O

D S C
E D O

C E Y
I O K

B E B
B W S

K B FRANK POWERS



No. 433. Illustrated Rebus—also a Double Acrostic.— [This is one Aunt Sue sent a long time ago, and it has been crowded out until now; so if we have not given the right name to it you must not blame her. When the parts of the rebuses are properly made out, the first and the last letters of each, read as an acrostic, will be the name of something you are no doubt all very fond of.—Ed.]

ANSWERS TO PUZZLES IN THE MARCH NUMBER.

DECAPITATIONS AND CURTAILMENTS.—1. Gapc, apc. 2. Grouse, rouse. 3. Homer, omcr. 4. Sagc, sag. 5. Heron, hero. 6. Bect, bee.

CROSS-WORD.—Rheumatism.

SQUARE-WORD. P A R I S
A S I D E
R I S E N
I D E A S
S E N S E

NUMERICAL ENIGMA.—Thread (Hated, Red hat [the Cardinal's], Dearth).

ARITHMOREMS.—1. Hold. 2. Folio. 3. Attentive. 4. Ivory. 5. Going. 6. Option. 7. Nook. 8. Poise.

ALPHABETICAL ARITHMETIC.— 292)1249406(4278 (Key: Hysterical.)

GEOGRAPHICAL HOUR-GLASS.—Meshickeman.

B A B E L M A N D E L
W O R C E S T E R
P A I S L E Y
S I H O N
A I X
C
O K A
O N E G A
M A R M O R A
S A G H A R B O R
A L B U Q U E R Q U E

Pt.—A word once spoken can not be brought back by a coach and four.

AUNT SUE'S NOTICES TO CORRESPONDENTS.

BELLA C. E.—To "find out an anagram," print the letters on a piece of card, then cut them apart and rearrange them into the original word. For instance, here is an anagram—"DO, PAT." Now print upon a strip of card (or paper) "D O P A T"; cut each letter separate, and twist them about until you have the original word, which is "ADOPT." The method of making or "finding out square-words" I described very thoroughly in the May number of the *Agriculturist*, 1871.

BESSIE BENNETT.—Very heartily do I exclaim "God speed!" to the women who engage in good works; but in the matter you speak of I dread reaction.

Thanks, for letters, puzzles, etc., to E. S. R., Jere P., F. S., Bessie Bennett, J. B. K., Robt. F. J., B. C. E., Minnie F. D., and W. H. S. F.

All communications for the *Puzzle-Box* should be addressed to "Aunt Sue," P. O. Box 111, Brooklyn, N. Y. [and not ever to the office of the *Agriculturist*.—Ed.]

An Impersonation.

"An Impersonation: what is that?" you will say. The picture is an impersonation. Now, don't be in a hurry and think that impersonation is another name for frogs. To impersonate is to give an animal or other thing the qualities of a person. In the picture frogs are made to appear as persons, and being represented as doing as persons do, they look exceedingly ridiculous. It is just for the ridiculousness of it, the fun of the thing, that we give this picture; for we think it well to have once in a while a nonsense picture with those of a different kind. We do not know but are very sure that this picture was drawn by a French artist. The French have a great fancy for these impersonations, and some of

sects were the only inhabitants, and there carried on all the business and various operations that men and women do in this world. You may imagine that the pictures were very funny. There was a band of music, with

Making an Acquaintance.

We like those boys on the fence, especially the oldest one. The good old cow has a calf, and instead of bouncing roughly into the presence of the frightened little stranger, they make their approach quietly, and one of them brings a gift of welcome in his hand, with the hope of forming an acquaintance. Is there anything more awkward and, so to speak, unreasonable, than a young calf? It has no beauty in its early days and is exceedingly obstinate and stupid. It seems to know just one thing: that its mother's milk is its own property, and there is just one right and proper way for it to get it, and it takes a great deal of teaching and requires great patience in the teacher to make it drink milk. It is not likely that the calf will eat the apple that the boy has brought, but it shows that the youngster knows what every boy and girl ought to know, that the way to treat all animals is to make friends with them from the beginning. The little calf does not meet the boys' advances now, though the mother does in her looks seem to try to encourage it; but it will soon, and before long will be glad to have the boys pet it. Did you ever notice the difference between colts that had been petted from the first and those that had been "shooed" at just to see them kick up their heels and scamper across the pasture? We have seen colts not a year old that would come from any part of a large lot when called, and seem to enjoy a little petting and coaxing as much as a boy enjoys approving words from his father or mother. When colts and calves hear only pleasant tones, when they are taught, as they soon may

be, to look upon us as their friends, there will be little need of what is called "breaking" of horses or steers; having been always treated kindly, they may be taught without trouble to do what is required of them. Animals that have become attached to you by kindness



I OUT, AND CURL AND SHAVE WITH CARE, AND TO BALD HEADS RESTORE THE HAIR.

crickets and all the noisy insects playing away for dear life. A quack doctor, represented by a duck with his patient, very properly a goose, and all sorts of amusing things. Frogs are especially suited to this kind of impersonation, and in the picture the obsequiousness of



MAKING AN ACQUAINTANCE.

their artists are wonderfully skillful at making them. We have seen a large French book, called "Another World," in which the writer pretends that in some mysterious way he went to some planet where heasts, birds, and in-

the barber and the patience of his sitter are very cleverly done; and we must not forget to notice the satisfaction with which the one who has had his "shave" takes his sun-umbrella, and walks off to pleasure or business.

appear to really wish to please you if they only know what you want them to do. They are slow in finding this out, and need a great deal of patient showing. When they once understand they will gladly obey.

Life Insurance.

HOW to get money, or to keep it, is by no means the most difficult or desirable of accomplishments. It requires but a very ordinary ability; and if that ability is not accompanied by other qualities of a higher order, its possession is not to be greatly coveted. But one thing it does require, without which no ability can succeed, and that is—money. A fortune can no more be acquired without some capital to start with, than a crop of corn can be raised without corn to plant. The plowing and cultivating may be done ever so diligently and well, but without the seed there can be no crop.

That "first thousand dollars" necessary to a successful embarkation after the golden fleece must first be obtained, or the ambitious argonaut sets his sails and launches his ship in vain. Thousands and tens of thousands have essayed the voyage without it, only to meet with certain shipwreck of fortune or character, or of both. In the effort to get that "first thousand dollars" what years of weary toil and care must usually be expended.

The number is almost incalculable of those who, having the power of success, lack the means; and whose lives, that might yield a rich revenue of good, are spent in comparatively profitless drudgery, delving after that "first thousand dollars," the possession of which is to be the corner-stone of future fortune.

There is but one way for the poor man to save his children from this slavery, and that is by leaving them the little legacy which delivers from the necessity that has been laid upon him, and puts them on the high road to success, if the elements of success be in them. To do this in a single sum, by a single saving, is impossible; but to do it by many savings of many sums is possible, if life is spared him until the end is attained.

But, if life is not spared, what then? Why, for his children, the same dreary, hopeless life which he has endured.

From this the United States Life Insurance Company, of this city, eminent among the best of such institutions for its safety, economy, and liberality, furnishes a ready deliverance. It furnishes to every man the way of purchasing for his little ones that golden key which unlocks the door of opportunity—that "start in life" which wins the race—that "first thousand dollars," which is the fulcrum resting upon which, with the leverage of faith and industry and honesty, the world itself may be moved.

S. B. Parsons & Sons offer at Flushing, N. Y., transplanted Trees and Plants.

(By Long Island Central R.R. to Kissena Station.)

GEO. A. PRINCE & CO. ORGANS & MELODEONS.

The Oldest, Largest and Most Perfect Manufactory in the United States.

53,000

Now in use.

No other Musical Instrument ever obtained the same popularity.

Send for Price-Lists.

Address

BUFFALO, N. Y.



\$600 A MONTH made honestly with Stencil and Key-Cheek outfits. Catalogue and samples free. S. M. SPENCER, 117 Hanover St., Boston, Mass.

\$490 Piano. Circulars free. U. S. Piano Co. 810 B'dway, N. Y.

(CIRCULAR.)

Consumers Importing Tea Co., No. 8 Church Street, P. O. Box 5,509. New York City.

This is a combination of capitalists to supply the consumers of Teas throughout the United States on the mutual principle.

We have experienced agents in all the best districts of China and Japan to select Teas especially for our trade.

We expect every consumer of Teas to render us all the assistance they can in carrying out our enterprise, as we make a specialty of SUPPLYING CONSUMERS ONLY (and allow no middlemen to make any profit on our importations), which will enable us to supply them with Teas at prices lower than have ever been known, and of those fine qualities that seldom reach the interior, being sold only in the large cities and among the very wealthy.

Hoping the consumer will take an interest in our enterprise, and send at once for a circular with full explanations of how to proceed to obtain our goods, we remain,

Most respectfully yours,

Consumers Importing Tea Co., No. 8 Church Street, P. O. Box 5,509. New York City.

Entered, according to Act of Congress, in January, 1874, by the Consumers Importing Tea Co., in the Office of the Librarian of Congress, Washington, D. C.

THE BEST PAINT



IN THE WORLD.

Branch Office and Factory: 506 West Street, NEW YORK, Any Shade from Pure White to Jet Black.

A combination of the purest paint with India Rubber, forming a SMOOTH, GLOSSY, FIRM, DURABLE, ELASTIC, and BEAUTIFUL Paint, unaffected by change of temperature; is perfectly water-proof, and adapted to all classes of work, and is in every way a better paint for either inside or outside painting than any other paint in the world. Being from one fourth to one third cheaper, and lasting at least three times as long, as the best lead and oil paints.

Be sure that our TRADE-MARK (a fac-simile of which is given above) is on every Package.

Prepared ready for use, and sold by the gallon only. There has never been a paint offered the public that has become so popular (in the same time) and given as perfect satisfaction as the Rubber Paint. Send for sample card and testimonials.

DEVOE'S BRILLIANT OIL.

Safe beyond any chance. The finest illuminator in the world.



Diploma of Merit received from Vienna Exposition of 1873. Put up in barrels and faucet cans.

Ask for Devoe's Brilliant Oil and take no other. THE DEVOE MFG CO., New York, Proprietors. For sale everywhere.

TO FARMERS AND MARKETMEN.

You want none but the very best of seed, grown from carefully selected seed stock. With the money you have to invest in manure, help, and glass, you know you can not afford to use any other; you feel very anxious about it; TRY MINE. Catalogues free to all.

JAMES J. H. GREGORY, Marblehead, Mass.

FAIRBANKS' SCALES THE STANDARD OF THE WORLD. HIGHEST PRIZE AT VIENNA, 1873.



KNIGHTLY CROSS OF THE

IMPERIAL ORDER OF FRANCIS JOSEPH, CONFERRED BY THE EMPEROR OF AUSTRIA Upon the Inventor of the FAIRBANKS SCALE.

E. & T. FAIRBANKS & CO'S Principal Scale Warehouses.

- FAIRBANKS & CO.....311 Broadway, New York. FAIRBANKS & CO.....166 Baltimore St., Baltimore, Md. FAIRBANKS & CO.....53 Camp St., New Orleans. FAIRBANKS & CO.....83 Main St., Buffalo, N. Y. FAIRBANKS & CO.....333 Broadway, Albany, N. Y. FAIRBANKS & CO.....408 St. Paul St., Montreal. FAIRBANKS & CO.....London, Eng. FAIRBANKS & BROWN & CO.....2 Milk St., Boston, Mass. FAIRBANKS & EWING.....715 Chestnut St., Philadelphia, Pa. FAIRBANKS & MORSE & CO.....111 & 113 Lake St., Chicago. FAIRBANKS & MORSE & CO.....139 Walnut St., Cincinnati, O. FAIRBANKS & MORSE & CO.....182 Superior St., Cleveland, O. FAIRBANKS & MORSE & CO.....48 Wood St., Pittsburgh. FAIRBANKS & MORSE & CO.....cor. 5th & Main Sts., Louisville, Ky. FAIRBANKS & CO.....302 & 304 Washington Ave., St. Louis. FAIRBANKS & HUTCHINSON.....San Francisco, Cal.



GREAT WESTERN GUN WORKS PITTSBURGH PA Rifles, Shot Guns, Revolvers, Pistols, Ammunition, Fishing Tackle, etc. For Price-list, see page 157, April No. Am. Agriculturist, or address, with stamp, GREAT WESTERN GUN WORKS, 285 Liberty St., Pittsburgh, Pa.



FOR SALE BY DRUGGISTS.

W. A. COVERT & CO., Produce Commission Merchants, No. 68 Pearl Street, New York. "Quick sales and prompt returns." Send for our weekly Prices-current and Marking Plate.

SOMETHING NEW in relation to Boys' Boarding School. 8th year. No extras. All books furnished free to scholars. Catalogues free. Address HIRAM H. POST, Prin., Sing Sing, N. Y.

Before You Buy,

Send for a circular of

- TURTLE HARROW,**
- EAGLE SEED SOWER,**
- VICTOR HORSE HOE,**
- CLIPPER WHEEL HOE,**
- NEW SUBSOIL PLOW,**
- HODGE'S SWIVEL PLOW.**

Each we unhesitatingly claim are the best in their respective line in the world.

CARR & HOBSON,
56 Beckman Street, New York.

TO FARMERS & PLANTERS.



DOUBLE REFINED POUDERETTE for sale in lots to suit customers. This article is sold for half the price of other fertilizers, and is cheaper for Cotton, Corn, Tobacco, and Vegetables than any other in the market. Price, delivered on board in New York City, \$25 per ton. Task attention to the following testimonials:

CHARLES A. MESSENGER, Providence Co., R. I., writes: "The Double-refined Poudreite I bought of you has given satisfactory returns, and I consider it the best of anything I can use for an early crop."

THOMAS W. LATHAM, Providence Co., R. I., writes: "I would rather have your Double-refined Poudreite than any phosphate I ever used. Where I used it on Potatoes it was far ahead of any other manure."

L. H. SHELDON, Sup't of the New Jersey State Reform School, writes: "We have used Poudreite for several years upon our farm crops, and for the money invested we have found nothing that has done us so much service."

S. J. KELLY, Burlington Co., N. J., writes: "I used Double-refined Poudreite on Rutabaga Turnips alongside of Peruvian Guano and Hen Manure. Where the Poudreite was applied the increase was thirty per cent over the others."

WILLIAM H. CADDY, Ocean Co., N. J., writes: "I used Poudreite on Corn, Sweet and round Potatoes, Onions, and Lima Beans. It brought forward my crops two weeks earlier. I think it the best manure I ever used, giving better results than Peruvian Guano, at much less cost."

VAN ANTWERP and VAN BUREN, Montgomery Co., N. Y., writes: "Poudreite has been used in this locality for ten years past, mostly on Corn, and those who have used it say they have from 1/4 to 1/2 more Corn by using the Poudreite."

W. F. GERKIN, of Essex Co., N. Y., writes: "I have used the Double-refined Poudreite for the last five years, and I consider it the cheapest fertilizer I can buy—giving the best results for the cost."

MILTON STRONG, Suffolk Co., N. Y., writes: "I gave Poudreite a thorough trial this year, using it upon Corn, Potatoes, Lima Beans, Tomatoes, and Vines, and I have never raised better crops. My Corn will yield 100 bushels of ears per acre, and my garden was the surprise and admiration of all who saw it."

HENRY T. HORTON, Cheshire Co., N. H., writes: "I find, from experiments made last year, the Double-refined Poudreite is the cheapest fertilizer to use on Tobacco. I put it beside Peruvian Guano with equal cost of both, and the Tobacco was 30 per cent better where I used Poudreite."

W. H. REMINGTON, Hartford Co., Ct., writes: "I have used Poudreite on Corn, Potatoes, and Tobacco. There was but one piece of Corn in the place equal to mine, and that had 30 loads of manure per acre and mine none. The Tobacco started as soon as set and grew luxuriant."

WM. S. POMEROY, of Hartford Co., Ct., writes: "I have used the Double-refined Poudreite for several years on Tobacco, and I think it one of the best fertilizers made for this crop."

A Pamphlet giving full directions, etc., sent free on application to

JAMES T. FOSTER,
66 Cortlandt Street, New York.

GENUINE Peruvian Guano.

FARMERS, AGRICULTURISTS, and DEALERS in Fertilizers have now an opportunity of obtaining this valuable manure in small or large lots, at importers' prices, by applying to the Special Agency just established for the purpose of delivering Genuine Peruvian Guano to consumers at any accessible port or railway station in the country. Full particulars given in circular mailed free on application to

R. BALCAZAR,
No. 53 Beaver Street, New York.

REFERENCES BY PERMISSION:
Messrs. HOBSON, HURTADO & Co., Financial Agents of the Peruvian Government, 52 Wall Street, New York.
Moses TAYLOR, Pres. National City Bank, 52 Wall St., N. Y.
J. C. TRACY, Esq., Peruvian Consul, 26 1/2 Broadway, N. Y.

FOR SALE--MANURE

from 180 horses for a year. For particulars, apply to the TROY & LANSINGBURGH R.R. CO., Lansingburgh, N. Y.

Gas Lime Given Away

and put on board vessel, at the Dock of the Brooklyn Gas Light Co., East River, next to Navy Yard.

MORRIS, TASKER & CO., PASCAL IRON WORKS.

PHILADELPHIA.

TASKER IRON WORKS, NEWCASTLE, DELAWARE.

Office.....FIFTH AND TASKER STREETS, PHILADELPHIA.
Office and Warehouse.....No. 15 GOLD STREET, NEW YORK.
Office and Warehouse.....No. 36 OLIVER STREET, BOSTON.
Manufacturers of Wrought Iron Welded Tubes, plain, galvanized, and rubber coated, for gas, steam, and water. Lap-Welded Charcoal Iron Boiler Tubes, Oil-Well Tubing and Casing, Gas and Steam Fittings, Brass Valves and Cocks, Gas and Steam Fitters' Tools, Cast Iron Gas and Water Pipe, Street Lamp Posts and Lanterns, Improved Coal Gas Apparatus, etc.
We would call the Special Attention to our Patent Vulcanized Rubber-coated Tube.
THOMAS T. TASKER, Jr. STEPHEN P. M. TASKER.

No More Loose Bolts and Nuts.

THE CELEBRATED "CUMMING" LOCK-NUT, Patented June 16, 1868.

No More Rattling CARRIAGES and WAGONS.
No More Dropping Down of SHAFTS.
No More Lost Bolts from REAPERS and MOWERS.

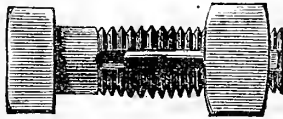

No More Flying Teeth from THRESHERS.
No More Bills for Repairs Continually.
SEND FOR PRICE-LIST AND CIRCULARS TO

THE LOCK-NUT AND BOLT CO. OF N. Y., No. 61 Broadway, New York.

Licenses granted to Manufacturers of Agricultural Machines, Carriages, etc.

Samples from B. E. Hale & Co., 56 and 58 Park Place, N. Y., Sole Agents for Eastern States.

BUILDING PAPER!

Samples from Rock River Paper Company, Chicago, Ill.

FOR SHEATHING, ROOFING, DEAFENING, CARPET LINING, AND PLASTERING!

EVERY LADY SHOULD HAVE A SET OF GOODRICH'S "SPRING" HEMMERS

Consisting of Four Widths and a Dress Binder. Sent by Mail on Receipt of Price.
For Sale by all Sewing Machine Agents. } 205 State Street, CHICAGO, ILL.
Price, Only One Dollar. } H. C. GOODRICH, { 103 N. 10th St., PHILADELPHIA, PA.
Inventor of The Goodrich Tuck Marker.

Universal Fertilizer

Is in the form of a dry and fine powder, uniform and invariable. Send stamp for our descriptive circular.

We have had this fertilizer prepared expressly to offer to farmers and gardeners a substitute for Peruvian Guano, which shall exceed it in practical value for all crops.

Price \$60 per ton, in bbls. of 250 lbs. each. Sample bags. Also PERUVIAN GUANO direct from Government Stores. Price reduced to \$70 per ton, under guarantee.

Various other Fertilizers, Seeds, and Agricultural and Horticultural Implements, Tools, and Machines, etc.

R. H. ALLEN & CO.,
P. O. Box 376. 189, 191 Water St., NEW YORK.

Farm Carts and Wagons

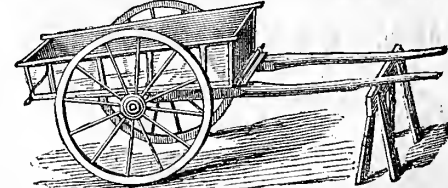

Always on hand and made to order. Also every description of Heavy Cart and Wagon for city and country use and for shipping. Illustrated Circulars free by mail.

JOHN L. KIPP, 163 Eldridge Street, New York.

HARNESS



FOR THE TRACK, ROAD, PARK OR FARM.

Single at \$8, \$12, \$15, \$20, \$25, to \$200 per Set. Double at \$25, \$30, \$35, \$40 to \$500 per Set. Blankets, Sweats, Hoods, Muzzles, Clipping Machines, and Harness furnishing goods of every description, style, and grade, adapted for use on the Track, Road, Farm, or Stable.

C. M. MOSEMAN & BRO., Manufacturers, 114 Chambers St.

"Send for Descriptive Price-list."

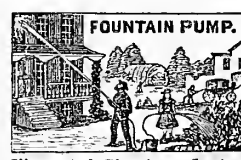

GARDEN ENGINE and FIRE EXTINGUISHER. For Washing Windows, Carriages, etc. Protect Buildings from Fire, and Trees, Vines, etc., from Insects. Throws water 50 ft. Easily carried. No Dwelling, Country Home, or Factory should be without the Fountain Pump. Send for large Illustrated Circular. J. A. WHITMAN, Sole Proprietor and Manufacturer, Providence, R. I.



Goodenough Horse-Shoe.

Cheapest and Best. All fitted for Use. No Fires required.

Send for Circulars. Box 3,044, P. O., New York.

Sanford Corn.

In Minn., Ills., Mich., and other States, it has ripened in 85 days. It will yield more than any other variety which ripens as early. The best proof of its superiority is that from many sections where it has been tested I am now receiving large orders for seed. Selected Seed—sample by mail, 25c.; 1 qt., 60c.; 4 lbs., \$1. Peck, by ex., \$1.50; 1/2 bu., \$3; 1 bu., \$5. Send stamp for circular giving full description. Address **S. B. FANNING,** Jamesport, N. Y.



SCREW STUMP MACHINE. Safe, Economical, Cheap, and will pull the largest Stump with ease. Send for Circular to **GEO. CHAMBERLAIN & SON, OLEAN, N.Y.**

ASBESTOS ROOFING

EXTRACTS FROM
AMERICAN INSTITUTE
REPORTS.

"Practically FIRE-PROOF," Medal awarded 1870.
"The Best Article in the Market," 1-71.
"Is very strong, repels water effectually," 1872.
"We recommend it to all as the best in use," 1873.

The **ASBESTOS ROOFING** is adapted for steep or flat roofs in all climates, and can be cheaply transported and easily applied. Is furnished in rolls containing 200 square feet each, packed in strong skeleton cases. **ASBESTOS ROOF COATING**, for restoring and preserving roofs. In 5, 10, and 20 gallon kegs and barrels. **ASBESTOS PAINT**, for Shingle and Tin Roofs, and all outside work. In 1, 2, and 3 gal. cans, kegs, and bbis. **ASBESTOS CEMENT**, for repairing leaks on all kinds of Roofs. In 10-lb. pails, 25 and 50-lb. kegs. **ASBESTOS BOILER FELTING, ASBESTOS BOARD and PAPER, SHEATHING FELTS, ASBESTOS, etc.** **FIRE-PROOF COATING**, for inside of Factories, Railroad Buildings, Bridges, etc. In kegs and barrels. These materials are prepared ready for use, and are put up for shipment to all parts of the world. Send for Descriptive Pamphlets, Price-Lists, etc. **LIBERAL INDUCEMENTS TO GENERAL MERCHANTS AND DEALERS.**

Patentee and Sole Manufacturer, **H. W. JOHNS, 87 Maiden Lane, N. Y.**
ESTABLISHED 1855.

Carbonized Enamel IS AS PURE AS GLASS.

The Bridgeport M'fg Co.,
OF BRIDGEPORT, CONN.

(Office, No. 88 Chambers St., New York),
Have the exclusive control of this valuable enamel, and are using it to cover all of their celebrated

American Submerged Force Pumps.

They also enamel pipe inside and out, which delivers the water chemically pure. The Enamel is composed of vegetable matter, baked on so hard that a blow does not break it, and it resists acids that eat gold.

Gentlemen: I have examined the sections of Carbonized Enamel Pipe submitted to me by you. It is superior to any pipe I have ever seen for resisting acids and conducting water from springs or for use in connection with pumps, etc. The Enamel adheres with astonishing tenacity, withstanding even heavy blows; and the surface of the metal where the enamel is beaten off seems to be protected against the ordinary action of water.

M. C. WELD,

Late Associate Editor *Am. Agriculturist*.

MUDGE & WOODS, No. 88 Chambers St., N. Y.,
are the exclusive selling agents of the Bridgeport M'fg Co. for the Licenses of States, counties, and towns rights for the American Submerged Suction and Force Pumps.

THE PULSOMETER.



The simplest, most durable, and effective steam pump now in use. Will pump gritty or muddy water without wear or injury to its parts. It can not get out of order.

C. HENRY HALL & CO.,
20 Cortlandt Street, New York City.

BRANCH DEPOSITS:

104 Sudbury St., Boston, Mass.
1,327 Market St., Philadelphia, Pa.
59 Wells St., Chicago, Ill.
South Western Exposition, New Orleans, La.
811 and 813 North Second St., St. Louis, Mo.

TATEM & DAVENPORT, Produce Commission Merchants.

Office, No. 1 Delaware Ave. Market,
PHILADELPHIA, PA.

Southern Produce a specialty. Correspondence solicited.
Consignors advised daily.

Established 1862.

Self-Propel- For Cripples

Can be easily in or out doors, using the use of State your weight for illustrated ferent styles and

Please mention this paper.



ling Chairs and Invalids

propelled, either by any one hands, and send stamp catalogue of dif- ferences.

S. A. SMITH,
No. 32 Platt St.,
N. Y. City.

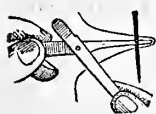

EVERY LADY that uses a Sewing Machine needs the

MAGIC THREADER

By mail, 25 cts.; with 1/2 doz. standard needles, 50 cts. Full description in *Am. Agriculturist* for April, page 153. In ordering, give name of Machine. Agents wanted everywhere. **The ARGO M'fg Co.,** Box 347, Springfield, Mass. Please mention *Am. Agriculturist*.

FARM FOR SALE

IN DANBURY, CONN.

Address **J. M. IVES.**

AGENTS LOOK!—\$12 a day made selling Scissors Sharpener and other wares. Sample 25 cts. Catalogue free. **T. J. HASTINGS & CO.,** Worcester, Mass.

BAIRD'S BOOKS

For Practical Men.

My new revised and enlarged Catalogue of PRACTICAL AND SCIENTIFIC BOOKS, 96 pages, 8vo., will be sent, free of postage, to any one who will favor me with his address.

HENRY CAHAY BAIRD,

Industrial Publisher,

406 Walnut St., Philadelphia.



VICTOR HUGO'S LATEST AND GREATEST NOVEL.

This remarkable and powerful story, dealing with the events of the French Revolution, begins in THE NEW YORK SEMI-WEEKLY TRIBUNE, March 27th, and will be continued regularly in that paper. THE SEMI-WEEKLY TRIBUNE is \$3 per year, or 30 cents per month (8 numbers) for single copies; \$2.50 per year, or 25 cents per month (8 numbers) in clubs of five or over.

Address THE TRIBUNE, NEW YORK.

THE SABBATH.

Greatest and Latest of Church Choir Books. For all denominations. \$13.50 a doz. Sample copy, \$1.25

CLARKE'S NEW METHOD FOR THE PIANO-FORTE. THE BEST OF INSTRUCTION BOOKS. Has the endorsement of all good teachers who have examined it. Sent by mail, \$3.75.

"THE AMATEUR."

THE GREAT MUSICAL MONTHLY! ELEVEN pages of new music—and NINE pages of musical matter in each number. Sample copy, 10 cts. Subscription, including beautiful CHROMO, \$1.00 per year.

LEE & WALKER'S MUSICAL ALMANAC.
Sent free to any address.

GETZE'S SCHOOL FOR THE ORGAN. "THE UNRIVALED INSTRUCTOR." The best work for teachers and pupils. Sent by Mail, price, \$2.50.

Lee & Walker, 922 Chestnut St. Philadelphia.

SONGS OF GRACE & GLORY

The very best Sunday-School Song Book. By **W. F. SHERWIN and S. J. VAIL.** 160 Pages Splendid Hymns, Choice Music, Tinted Paper, Superior Binding. Price in Boards, 35c.; \$30 per 100. A Specimen Copy in Paper Cover mailed (as soon as issued) on receipt of Twenty-five Cts. Orders filled in turn. **READY MAY 1st.** **HORACE WATERS & SON,** 481 Broadway, New York.

The Kansas Farmer.

In its 12th year. Enlarged, improved, and published weekly. All about Kansas. A large corps of able writers. Sample copy free to all applicants. **T. K. HUDSON, Ed. and Propr.,** Topeka, Kansas.

AGENTS WANTED FOR THE LIFE AND PUBLIC SERVICES OF

Charles Sumner,

By **C. EDWARDS LESTER.**

This work has been long in preparation, and is now completed, with an account of his lamented death; the tributes of the nation at his grave, and the universal sorrow of the friends of humanity throughout the world. The volume will embrace about 600 pages, 8vo., with a portrait on steel of the late Senator, and numerous illustrations. Send \$1.50 for prospectus, certificate for territory, and outfit. **U. S. PUBLISHING CO.,** New York.

AGENTS WANTED FOR THE HISTORY OF THE GRANGE MOVEMENT OR THE FARMER'S WAR AGAINST MONOPOLIES.

Read what leading Grangers say of the book: **T. A. THOMPSON, Esq.,** Lecturer of the National Grange, writes: "There is a great demand for information concerning the Order. This you have met in your *History of the Grange Movement* in an admirable manner. The work is opportune, and merits an extensive circulation."

Col. A. B. SMEDLEY, Master of the Iowa State Grange, writes: "I have received your very excellent book; am much pleased with it. Many thanks for the copy sent me. I prize it highly."

Mr. D. B. MAUGER, Master of the Penn'a State Grange, writes: "I return to you my sincere thanks for the *History of the Grange Movement*. I have perused it with much interest. It is indeed stored with 'Golden Grain' for every Patron's family, and should be in the household of every Patron in the land. I can cheerfully recommend it." Send for specimen pages and circulars containing terms to Agents, and many more endorsements from leading Grangers. Address

NATIONAL PUBLISHING CO., Philadelphia, Pa. **CAUTION.** Unscrupulous publishers have taken advantage of the great demand for this *History of the Grange Movement*, to issue unreliable works on the subject—mere compilations from agricultural newspapers. Do not be imposed upon. See that the book you buy is indorsed by the leading Grangers.

AGENTS WANTED for the new book,
LIFE AND ADVENTURES OF
A Kit Carson
by his comrade and friend, **D. W. C. PETERS, Brevet Lt. Col. and Surgeon, U.S.A.,** from facts dictated by himself. The only TRUE and AUTHENTIC life of America's greatest HUNTER, TRAPPER, SCOUT and GUIDE ever published. It contains full and complete descriptions of the Indian tribes of the FAR WEST, as seen by Kit Carson; who lived among them all his life. It gives a full, reliable account of the MODOCs, and the MODOC WAR. As a work of HISTORY, it is invaluable. A grand opportunity for agents to make money. Our illustrated circulars sent free to all applicants. Write and secure territory at once. **DUSTIN, GILMAN & CO.,** Hartford, Conn.

Do you want Employment

We will give you immediate, steady, honorable work, which will pay you beyond all your expectations. Thousands at work for us are now making from \$100 to \$300 per month, and thousands more can do it. The business is in introducing our publications in your own and other towns. With MARK TWAIN'S or JOSH BILLINGS'S new works, with "MY OPINIONS and BETSEY BOBBET'S," and with many others out of our list, you can secure a fine income easily. Write us for information. We send it full and free. Address **AMERICAN PUBLISHING CO.,** Hartford, Conn.

AGENTS WANTED FOR THE CENTENNIAL GAZETTEER OF THE UNITED STATES.

A complete encyclopedia of all the States, counties, townships, cities, villages, post-offices, mountains, rivers, lakes, etc., with their climate, population, agriculture, manufactures, mining, commerce, railroads, capital, education, government, and history, showing the gigantic results of the **FIRST 100 YEARS OF THE REPUBLIC.** Agents make \$100 to \$300 per month. Send for circular. **ZIEGLER & MURDY,** Philadelphia, Pa.; Cincinnati, O.; St. Louis, Mo.; Springfield, Mass.; Chicago, Ill.

Scribner's Lumber & Log-Book.

OVER HALF A MILLION COPIES SOLD. This book is the most full and complete book of its kind ever published. It gives correct measurement of all kinds of lumber, logs, plank, cubical contents of square and round timber, stave and heading bolt tables, wares, rent, board, capacity of cisterns, cord-wood tables, interest, etc., and has become the Standard Book throughout the United States and Canada. Be sure and get the *New Edition, with Doyle's Log-Table.* Ask your bookseller for it, or I will send you for 35 cents, post-paid. **G. W. FISHER, P. O. Box 283, Rochester, N. Y.**

"EDEOGRAPHY" A new book on the art of writing by sound; a complete system of Phonetic Short Hand—the shortest, most simple, easy, and comprehensive, enabling any one, in a short time, to report trials, speeches, sermons, &c. The Lord's Prayer is written with forty-nine strokes of the pen, and 140 words per minute. The unemployed should learn this art. Price, by mail, 50 cts. Agents wanted. Address **T. W. EVANS & CO.,** 139 S. Seventh Street, Phila., Pa.

CLAVELACK College and Hudson River Inst., at Clavelack, N. Y. 20 instructors. **ALONZO FLETCHER, Ph. D., Pres.**

ARE YOU GOING TO PAINT?
OVER 200,000 HOUSES

PAINTED WITH THE

Averill Chemical Paint.

White and all the fashionable shades mixed ready for use and sold by the gallon.

EXTRACTS FROM OUR LETTERS.

HON. JAS. NEBLEY, Pittsburgh, Pa.: "Altogether I find the 'Averill' the cheapest and best."
PETER HENDERSON, Esq.: "The 'Averill' has proved superior to lead and oil."
C. W. SPOONER, Treas., Cordage Co., Plymouth, Mass.: "The 'Averill Chemical' has proved good."
C. A. ALLYN, Esq., Palmyra, N. Y.: "The 'Averill Paint' is as bright to-day as when applied three years ago."

Hundreds of testimonials from owners of the finest residences in the country, with Sample Card of Colors, furnished free by dealers generally, and by the

AVERILL CHEMICAL PAINT CO.,
32 Burling Slip, New York; or 132 East River St., Cleveland, Ohio.

THE
Hope Seat Spring.

For Farm Wagons, Trucks, Carts, Mowing Machines, and Coal Carts. The best and Easiest-Riding Spring ever invented. Every Spring Warranted. Good agents wanted in every city and town in the United States. Send for Circular.

BENJ. F. WELLS, Sole Agent,
47 Dey St., New York.

HAKES' IMPROVED
SWIVEL PLOWS,
For Level Land and Side Hill,



Overcome all objections in Swivel Plows heretofore made for plowing level land, and the same results are obtained as with land-side plows. Possess a combination of advantages which recommend them to universal use, effecting the complete inversion and pulverization of the soil on level as well as uneven surfaces, avoiding dead furrows and side ridges, giving an even surface to the fields. The merits of these Plows are fully stated in our illustrated and descriptive circular, which will be sent by mail, free, to any address. Made only by

AMES PLOW COMPANY,
53 Beekman St., New York,
and Quincy Hall, Boston.



ZERO
Refrigerator,
WITH COOLER.
Best in the World.
Send for Book.
A. M. LESLEY,
224 West 23d St.,
NEW YORK.

Lovejoy's New Style
GLASS CUTTER
AND PUTTY KNIFE

Cuts glass better than a diamond. Everybody should have one. Any child can use it. Sent to your address on receipt of 50 cents and stamp by

ALVAN L. LOVEJOY
229 Washington St.,
Boston, - - - - - Mass.
Liberal discount made to dealers.

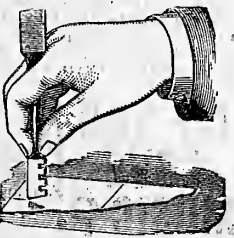

Every package guaranteed above standard.

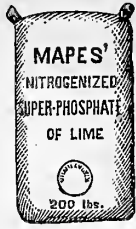

Liberal Inducements to Dealers.

B. K. BLISS & SON, 23 Park Place, N. Y.
ALFRED BRIDGEMAN, 86 Broadway, N. Y.
JAMES M. THORBURN & CO., 15 John St., N. Y.

Price Reduced to \$50 per Ton.
The most Economical Fertilizer for Farm and Garden.

COMPOSED OF
Bones, Flesh, Blood, Calcined Bones, Phosphatic Guano, Potash, and Sulphuric Acid.
Ammonia, 3.57. } Analysis on dry basis, April 9th, 1874; cargo, 394 tons; Sch.
Decomposed Phosphoric Acid, 14.57. } W. J. Parks; by Dr. I. Walz, New York.
Ammonia, 3.24. } Analysis on dry basis, January 10th, 1874, by G. A. Liebig,
Decomposed Phosphate, 25.00. } Baltimore, Md.

ALSO

Mapes' ODORLESS Ammoniated Superphosphate
For Lawns, Vegetable and Flower Gardens, etc., around dwellings.
Packed in bags, 200 lbs. each—\$60 per ton. Packed in small bags—30 cents each.

SEND FOR CIRCULAR TO

CHARLES V. MAPES, 160 Front St., N. Y.

R. C. REEVES, 185 Water St., N. Y.
PAUL C. COFFIN & CO., cor. West and Duane Sts., N. Y.
H. B. GRIFFING, 69 Cortlandt St., N. Y.

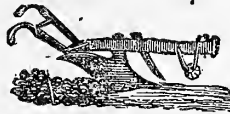

Farm Implements
AND
FERTILIZERS.

Buy the Best and at Lowest Prices.



Agricultural Almanac Sent Free.

H. B. GRIFFING,
58 & 60 COURTLANDT STREET, N. Y.

FARMS IN VIRGINIA,

With Dwellings, Barns, etc. Vegetation for New York markets four to six weeks earlier than New Jersey lands.

Quick and Cheap Steam Transportation to All the Northern Markets.

Prices \$5 to \$25 per acre. Farms both large and small. Lists with full particulars by addressing

WM. P. MOORE & CO., Suffolk, Va.

NIAGARA FIRE INSURANCE COMPANY,
201 Broadway, N. Y.

Capital Stock.....\$500,000
Cash value of Assets.....\$7,308,221
Total Liabilities.....\$2,502

Net Assets.....\$1,225,522
Dwellings and Farm Risks a speciality at all our Agencies.
HENRY A. HOWE, President.
P. NOTMAN, V. P. and Sec'y.

THE PENN MUTUAL LIFE INSURANCE COMPANY OF PHILADELPHIA.

ASSETS ACCUMULATED, \$4,427,996.96.
The Penn is a purely mutual Company. All of its surplus premiums are returned to the members every year. Dividends may be applied to reduce the premium or increase insurance as desired. SAM'L C. HUEY, Pres.
General and Local Agents wanted in the Middle and Western States. Apply to H. S. STEPHENS, Vice Pres. No. 921, Chestnut Street, Philadelphia, Pa.

Steel Pens!
Sold by all Dealers.

No. 91 JOHN ST., NEW YORK.
HENRY HOE, Sole Agent. JOSEPH GILLOTT & SONS

Sexual Physiology.

By R. T. TRALL, M. D. Containing Sexual Generation; the Physiology of Menstruation; Impregnation; Pregnancy; Parturition; Lactation; the Law of Sex; Regulating the Number of Offspring; The Law of Sexual Intercourse; Hereditary Transmission; Philosophy of Marriage. Prof. Wilder, of Cornell University, says it is the best work yet written on the subject. 20,000 sold. Price \$2.00 by mail. For \$3.50 we send this book, The Herald of Health for one year, and a volume of the Complete Works of Shakespeare, containing 1,000 pages and 36 Illustrations. Agents wanted. WOOD & HOLBROOK, 15 Laight St., New York.

AGENTS WANTED to sell our justly celebrated Articles for Ladies' wear. Indispensable and absolutely necessary. 10,000 SOLD MONTHLY. They give comfort and satisfaction. No female can well do without them. Sample sent, on receipt of \$2.00, FREE. Send for Illustrated Circular. LE PERLE RUBBER CO., 39 Chambers St., New York.

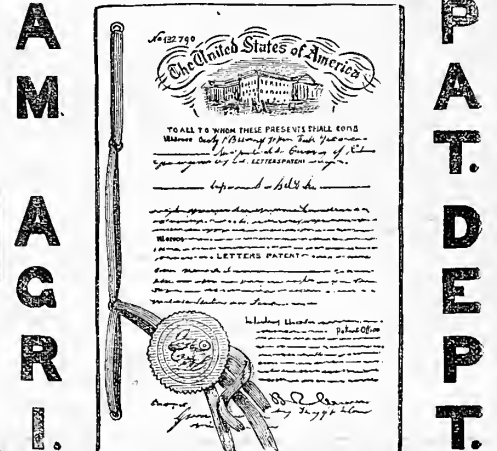

IMPORTANT TO INVENTORS.
American Agriculturist
PATENT DEPARTMENT

In compliance with the request of numerous inventors, we have organized a PATENT DEPARTMENT in connection with this office for the transaction of all business connected with

Securing Patents in the United States and foreign countries. The character for Reliability which has been maintained by the AMERICAN AGRICULTURIST for more than thirty years will be carefully guarded in this as in other departments.

All Inventors desirous of procuring patents at moderate cost are invited to forward (express prepaid) a model of their invention, with a brief description of its working. The model should not exceed one cubic foot in dimension. Upon receipt of model an opinion as to patentability will be given free of charge.

Preliminary Examination at the Patent Office, to determine patentability, will be promptly made for a fee of \$5. Litigation of Patents.

The services of the best counsel have been secured to prosecute or protect before the U. S. Courts and the Patent Office the claims of those intrusting their business to this agency.

Specifications, drawings, engravings, models, and all other appliances furnished at moderate prices.

In all dealings with this Department inventors may depend upon promptness, fidelity to their interests, and the best services which can be rendered by thorough experts. For full particulars, address

AMERICAN AGRICULTURIST PATENT DEPARTMENT,
ORANGE JUDD COMPANY,
245 Broadway, New York.

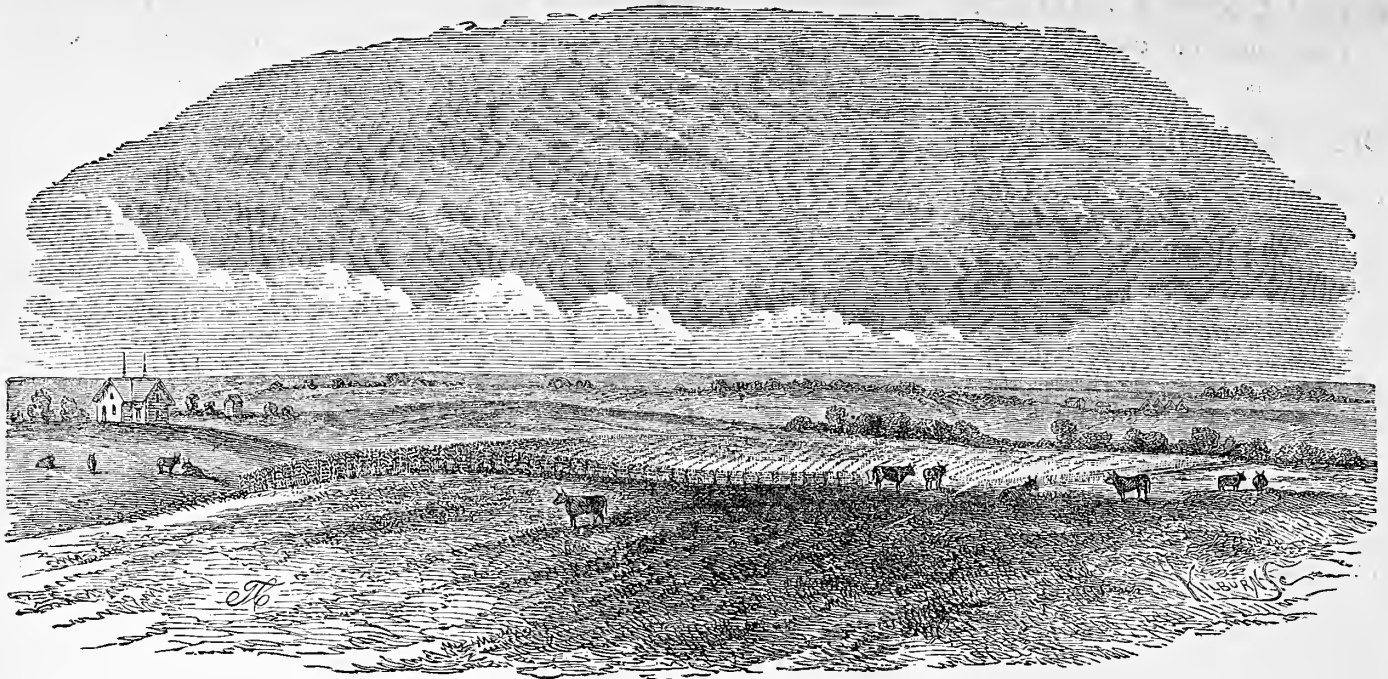

PRAIRIE, CORN-FIELD AND HERD OF CATTLE, SIX MILES WEST OF LINCOLN, NEB.

**IF YOU WANT A FARM OR HOME,
YOU SHOULD BUY OF THE
BURLINGTON AND MISSOURI RIVER RAILROAD CO.
IN IOWA OR NEBRASKA.**

- BECAUSE**—Their prices are low, ranging for the best land from Three to Ten Dollars per acre.
- BECAUSE**—No payments are required of the purchaser for four years, except interest at six per cent.
- BECAUSE**—After the fourth year only one seventh of the principal is payable annually till the whole is paid.
- BECAUSE**—You are not required to go into a wilderness, these being well-settled States, the population of which is rapidly increasing.
- BECAUSE**—The mildness of the climate and fertility of the soil is such that the settler can pay for his farm from the products raised upon it long before the time when the principal becomes due.
- BECAUSE**—Failure of crops from drought is unknown.
- BECAUSE**—Large allowances are made upon fare and freight, thus giving low rates on both to purchasers of this Company's lands.

AND YOU SHOULD BUY THIS YEAR.

BECAUSE—Purchasers of our lands in Nebraska during 1874 who cultivate one-half their land within two years from their purchase are allowed a reduction of twenty per cent on its price. **LARGE DISCOUNTS** also, FOR CASH, within One, Two, or Five Years.

Send for Circulars, with full information on all points, to

GEO. S. HARRIS, Land Commissioner,

At Lincoln, Nebraska, for land in Nebraska. At Burlington, Iowa, for land in Iowa.

Or to **W. D. COWLES**, General Agent, 317 Broadway, New York.

JAS. R. WOOD, General Agent, 59 Clark St., Chicago, Ill.



BUILDING FELT.

This water-proof material, resembling fine leather, is for outside work (no tar substances used) and inside, instead of plaster. Felt carpetings, etc. Send two 3-cent stamps for circular and samples.

C. J. FAY, Camden, N. J.

SOMETHING NEW.

LOTS OF FUN.

Endless amusement for both young and old.

THE GREAT PUZZLES.

They are sure to please everybody. Packages containing one dozen different puzzles sent anywhere for 25 cents. Address **PUZZLE COMPANY**, 735 Broadway, New York. Agents, you can sell them fast. Liberal discount.

WANTED—Agents, for the people's un-denominational, family paper, "THE CONTRIBUTOR." Fifteen departments; sixteen pages. Only \$1.00 a year. Rev. A. B. EARLE writes for it. A magnificent premium, "The Old Oaken Bucket." Nothing like it for Agents. One writes: "Took 33 subscribers the first day in 4 hours; and 47 the next day in 1 1/2 hours." Another: "Takes like hot cakes." Another: "Sells itself." Commissions large. For terms, samples, etc., address **J. H. EARLE**, Boston, Mass.

AGENTS WANTED. Combination Needle-Book and Portemouaie, with Chromos. Perfect Gems. Sample sent, post-paid, 75c. For illustrated circular send stamp. **J. BRIDE**, Hudson, Mass.

WANTED to employ reliable persons everywhere to represent our firm. Merchants, farmers, ministers, teachers, etc., etc. Good wages guaranteed. Address **Hudson River Wire Co.**, 125 Maiden Lane, N. Y., or 18 Clark St., Chicago, Ill.

ADVERTISERS should send to **GEO. P. ROWELL & Co.**, 41 Park Row, N. Y., for their *Eighty-page Pamphlet*, containing lists of 3,000 newspapers and estimates, showing the cost of advertising. Mailed free to all applicants.

FLORENCE

The Long-contested Suit of the FLORENCE SEWING MACHINE CO. against the Singer, Wheeler & Wilson, and Grover & Baker Companies, involving over \$250,000, is finally decided by the Supreme Court of the United States in favor of the FLORENCE, which alone has Broken the Monopoly of High Prices.

THE NEW FLORENCE
Is the ONLY machine that sews backward and forward, or to right and left. Simplest—Cheapest—Best.

SOLD FOR CASH ONLY. SPECIAL TERMS TO CLUBS and DEALERS.
April, 1874. Florence, Mass.

WANTED—Agents—\$75 to \$250 per month, everywhere, male and female, to introduce the GENUINE IMPROVED COMMON SENSE FAMILY SEWING MACHINE. This Machine will stitch, hem, fell, tuck, quilt, cord, bind, braid, and embroider in a most superior manner. Price only \$15. Fully licensed and warranted for five years. We will pay \$1,000 for any machine that will sew a stronger, more beautiful, or more elastic seam than ours. Address **SECOMB & CO.**, Boston, Mass.; New York City; Pittsburgh, Pa.; Chicago, Ill.; or St. Louis, Mo.

FERRACUTE PRESSES, DIES AND ALL FRUIT-CAN TOOLS

MACHINE WORKS BRIDGE TOWN, N. Y. SEND FOR LITHOGRAPH

LOVELL'S FAMILY WASHING MACHINE.—Price \$5. A perfect success. Warranted for five years. Agents wanted. Address **M. N. LOVELL**, Erie, Pa.

HOW TO MAKE MONEY AT HOME. 48 pp. Book free. **J. JAY GOULD**, Boston, Mass.

THE PATENT

ARION

PIANO-FORTE

Excels all others in Tone and Durability, and in Elegance of Finish they are Unsurpassed.

These Pianos are used exclusively in the New York Conservatory of Music, and are recommended by the Profession and the Press throughout the United States. Before purchasing, write for Illustrated Pamphlet, and mention the *Agriculturist*.

ARION PIANO-FORTE CO.,
No. 5 East 14th Street, New York City.

200 PIANOS & ORGANS
New and Second-Hand, of First-Class Makers, including Waters', will be sold at Lower Prices for cash, or on Installments, or for rent, in City or Country, during this month, by **HORACE WATERS & SON**, No. 481 Broadway, than ever before offered in New York. **SPECIALTY: Pianos and Organs to let until the rent money pays the price of the instrument. Illustrated Catalogues mailed. A large discount to Ministers, Churches, Schools, Lodges, etc.**

DO YOU LOVE MUSIC? If so, send us your address and the names of your musical friends, to whom we will mail, post-paid, our new Descriptive CATALOGUE of choice MUSIC and specimen copies of the "MUSICAL WORLD," containing \$1.00 worth of Music.

S. BRAINARD'S SONS,
Cleveland, Ohio.

Newly Revised and Enlarged Edition.

Practical Floriculture.

A Guide to the Successful Propagation and Cultivation of Florists' Plants.

By PETER HENDERSON,
Author of "Gardening for Profit."

Beautifully Illustrated. Price, Post-paid, \$1.50.

In this work, which has everywhere become so deservedly popular, not only is the whole "art and mystery" of propagation explained, but the reader is taught how to plant and grow the plants after they have been propagated. The work is not one for florists and gardeners only, but the amateur's wants are constantly kept in mind, and we have a very complete treatise on the cultivation of flowers under glass, or in the open air, suited to those who grow flowers for pleasure as well as those who make them a matter of trade. The work is characterized by the same radical common sense that marked the author's "Gardening for Profit," and it holds a high place in the estimation of lovers of floriculture. The new edition has been thoroughly revised by the author, and much enlarged by the addition of valuable matter.

The following are a few of the subjects embraced in the latest edition:

Laying out Flower Garden and Lawn; Designs for Grounds and for Greenhouses; Soils for Potting; Cold Frames; Hot-Beds; Greenhouses Attached to Dwellings; Modes of Heating; Propagation of Plants by Seeds and by Cuttings; Culture of the Rose and Tuberoses; Growing of Water-flowering Plants; Construction of Bouquets, Baskets, etc.; Parlor and Window-Gardening; Wardian-Cases and Ferneries; Insects; What Flowers Grow in the Shade; Culture of Grape-Vines under Glass; The Profits of Floriculture; How to Become a Florist, etc., etc.

THE ILLUSTRATED Book of Poultry,

With Practical Schedules for Judging, Constructed from Actual Analysis of the Best Modern Decisions.

By LEWIS WRIGHT,
Author of "The Practical Poultry Keeper," "The Brahma Fowl," etc.

ILLUSTRATED WITH Fifty Colored Portraits of Prize Birds, Painted from Life by J. W. Ludlow.

CONTENTS.

- | | |
|---|--|
| CHAP. 1.—Houses and Accommodation. | CHAP. 19.—Brahmas. |
| 2.—The Selection of Stock. | 20.—Malays. |
| 3.—Feeding and General Treatment of Fowls. | 21.—Game. |
| 4.—Eggs and Incubation. | 22.—Dorkings. |
| 5.—Artificial Hatching. | 23.—Spanish. |
| 6.—The Management of Chickens. | 24.—Hamburghs. |
| 7.—Fattening and Killing. | 25.—Polish Fowls. |
| 8.—Poultry as National Food. | 26.—French Breeds of Poultry. |
| 9.—The Utility of "Fancy Points." | 27.—American Breeds of Poultry. |
| 10.—Commencing a Strain. | 28.—Unclassed Varieties of Poultry. |
| 11.—Mating Stock for Breeding Prize Birds. | 29.—Bantams (Except Game). |
| 12.—Rearing, Care, and Exhibition of Prize Poultry. | 30.—Game Bantams. |
| 13.—Shows and Judging. | 31.—Wild Breeds of Poultry, Origin of the Domestic Fowl. |
| 14.—Buying, Selling, and Exporting. | 32.—The Guinea Fowl. |
| 15.—Enemies in the Yard. | 33.—The Turkey. |
| 16.—Diseases of Poultry. | 34.—The Pea Fowl. |
| 17.—Technical Terms. | 35.—Ducks. |
| 18.—Cochius. | 36.—Geese. |
| | 37.—Swans. |
| | 38.—Possible Additions to the Poultry Yard. |

Price, Postpaid - - - - \$15 00
Either of the above books sent post-paid on receipt of price by

ORANGE JUDD COMPANY,
245 BROADWAY, NEW YORK.



THE PRACTICAL POULTRY KEEPER.

A COMPLETE AND STANDARD GUIDE TO THE MANAGEMENT OF POULTRY, FOR DOMESTIC USE, THE MARKETS, OR EXHIBITION.

Beautifully Illustrated.

By L. WRIGHT.

NOTICES BY THE PRESS.

This book is a valuable manual for everybody who feeds chickens or sells eggs. It suits at once the plain poultryer who must make the business pay, and the chicken fancier whose taste is for gay plumage, and strange, bright birds. The most valuable portion is the first section, extending through fifty-five pages. These were written with the intention of producing a manual so plain, minute, and practical, that any one could, by using it as a guide, with no previous experience with poultry, become at once successful in producing eggs, young chickens, and fat fowls for market. The author has not missed his aim. The middle parts of Mr. Wright's Manual are taken up with minute directions for making show fowls for Fairs, a nice discussion of the good and bad points of the different breeds, and a brief sketch of such fancy stock as peafowl, pheasants, and water-fowl. Then follows a section on artificial hatching, and another, worth special attention, on large poultry yards. . . . A study of Mr. Wright's book will convince any farmer's wife that all she needs is to give a half hour each day, of intelligent and sagacious attention to her poultry, in order to obtain from them, not tape, and knitting needles, and buttons, and nutmegs merely, but the family supplies of sugar, shoes, and cloth. *New York Tribune.*

It is the most complete and valuable work on the matters of which it treats yet published. It will be found a plain and sufficient guide to any one in any circumstances likely to occur, and is illustrated with elegant engravings of many breeds of fowls. *Farmers' Cabinet.*

This is a reprint, with numerous wood engravings, of an English book, the object of which is to convey in plain language a great deal of practical information about the breeding and management of poultry, whether for domestic use, the markets, or exhibition. . . . The book is eminently practical, and we recommend it to farmers and others interested in breeding and selling poultry. *Philadelphia Press.*

It is a handsome volume, brought out in the best style, and enriched with nearly fifty illustrations. It is evidently the fruit of a thorough, practical experience and knowledge of fowls, and will be found a plain and sufficient guide in all the practical details of poultry management as a profitable business. *United Presbyterian.*

The subject is treated fully and ably by an experienced hand, and the volume will doubtless find a large sale among the growing class of poultry fanciers. It is embellished with numerous illustrative engravings. *New York Observer.*

The author has called to his aid all who were experienced in the subject whereof he writes, and the consequence is a volume of more than ordinary thoroughness and exhaustiveness. *Rochester Democrat.*

The book is a complete and standard guide to the management of poultry for domestic use, the market, and for exhibition. *Watchman and Reflector.*

PRICE, POST-PAID, \$2.00.

ORANGE JUDD CO.,
245 Broadway, New York.

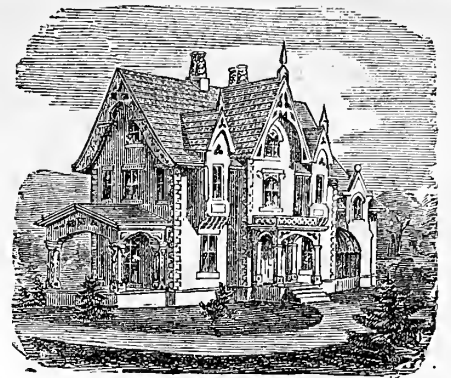

ATWOOD'S Country and Suburban HOUSES.

By DANIEL T. ATWOOD
ARCHITECT.

Illustrated with about 150 Engravings.

NOTICES BY THE PRESS.

The work is one that can well be read by every man about to build or buy a place of residence, as the author has much to say—and says it in a direct and simple manner—on all points connected with a matter so important, and which so closely concerns the comfort and the health of all persons. —*Traveler (Boston).*

The part of the volume preceding the designs contains useful suggestions on selection of localities, modes of building, properties of timber, painting, etc.—*Country Gentleman (Albany, N. Y.)*

It is a volume of nearly three hundred pages, amply illustrated, containing hints and suggestions as to the general principles of house-building, style, cost, location, symmetry, and modes of building. It is especially designed to encourage a taste for pleasant country houses.—*The Freeman (Montpelier, Vt.)*

This is a useful and valuable work, filled with suggestions as to the general principles of house-building, illustrated with about one hundred and fifty engravings.—*Watchman and Reflector (Boston).*

There is much in the book to recommend it to the attention of all; particularly the remarks on building material, appropriateness, the effects of different combinations of paints to produce harmonious colors, etc.—*State Republican (Lansing, Mich.)*

A splendid volume, illustrated with about 150 engravings. The directions and statements it gives are eminently plain and practical, and seem sufficient for the establishment of something more than houses merely, and that is homes.—*Rutland Herald (Vt.)*

An admirable work. It is just the book for any one contemplating the erection of a house or barn.—*Farmers' Cabinet (Amherst, N. H.)*

There are single chapters in it which are worth more than the price of the work (\$1.50), not only to those who are building anew or building greater, but to such as contemplate improvements, and, unfortunately—owing to bad jobs at the beginning, or decay's effacing fingers—there are few homes about which improvements are not needed.—*The World (New York).*

A valuable work, gotten up in the best style. It must prove both interesting and useful to all who wish a home in which beauty, taste, convenience, and economy are combined.—*United Presbyterian (Pittsburgh, Pa.)*

It contains some practical and common-sense advice as to the selection of sites, etc., which should be carefully considered by every one who is seeking where to locate his home, while the information given as to the principles and details of building is also of the utmost value for putting one in a position to know if he is having his work well done and getting his money's worth.—*Evening Mail (New York).*

PRICE, POST-PAID, \$1.50.

ORANGE JUDD COMPANY,
245 BROADWAY, NEW YORK.

"Our Preference is the Buckeye."
—American Agriculturist, June, 1872.

**TWO FIRST PREMIUM
GRAND MEDALS FOR MERIT
At Vienna, 1873.**

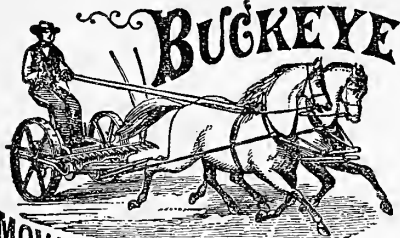

MOWER & SELF-RAKING REAPER
OFFICE
165 GREENWICH ST.
N.Y.
FACTORY
POKEEPSIE
N.Y.



MANUFACTURED BY ADRIANCE, PLATT & CO
STYLES, SIZES & PRICES TO SUIT ALL FARMERS.
Descriptive Circulars Forwarded by Mail.

THE WESTINGHOUSE Threshing Machines

AND

HORSE POWERS

Are not equaled by any in the market.

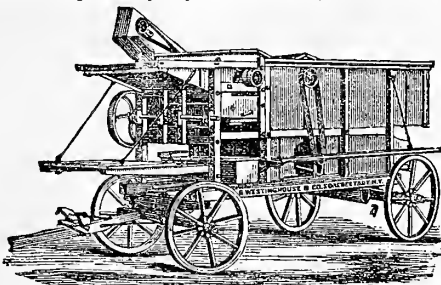

We make 4, 8, and 10 Horse-lever Powers of 2 and 3 Horse-Tread Powers, and Threshers for steam or any kind of Horse-Powers; also, our Improved Combined Clover and Grain Thresher. Send for Circular.

C. WESTINGHOUSE & CO.,
Schenectady, N. Y.

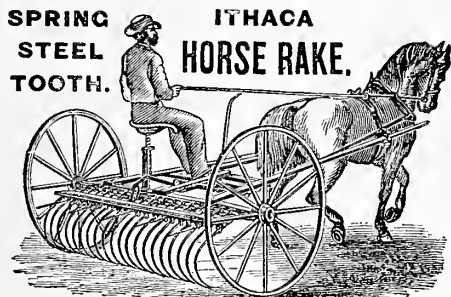

EXCELS ALL OTHERS.

Thousands in use giving entire satisfaction.
Manufactured by
WHEELER & MELICK CO., Albany, N. Y.
WILLIAMS BROS., Ithaca, N. Y.
YOUNGLOVE, MASSEY & CO., Cleveland, O.
GRAND RAPIDS MFG CO., Grand Rapids, Mich.

**DIRECT
DRAFT
EUREKA
MOWER.**
Give away Hay Tedders and Side Cut Machines. Save TIME and MONEY by using
Wilber's Direct Draft Eureka Mower.
You can cut and cure one third more grass in a given time, and gain 25 per cent in quality of hay.
For DESCRIPTIVE CIRCULAR, address
ISAAC W. WHITE, President,
Poughkeepsie, N. Y.

TWO GOLD MEDALS

For "Slow and easy movement of horses, its rods less than 1 1/2 miles per hour. Mechanical Construction of the very best kind, thorough and conscientious workmanship and made in every place, nothing slighted, excellent work," etc., as shown by Official Report of Judges, Threshers, Separators, Farming Mills Wood Market, Gettysburg with premium for the best in MINARD HARDER, Cobleskill, Scho. Co., N. Y.

At Great National Trial, at Auburn, N. Y.

For "Slow and easy movement of horses, its rods less than 1 1/2 miles per hour. Mechanical Construction of the very best kind, thorough and conscientious workmanship and made in every place, nothing slighted, excellent work," etc., as shown by Official Report of Judges, Threshers, Separators, Farming Mills Wood Market, Gettysburg with premium for the best in MINARD HARDER, Cobleskill, Scho. Co., N. Y.

HARDER'S Premium Railway Horse Power, and Thresher and Cleaner, awarded THE FIRST PRIZE, AWARDED THIS MACHINE.

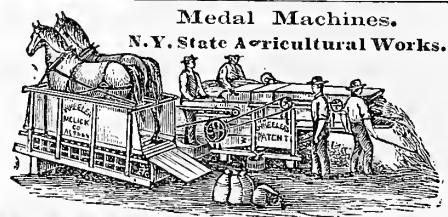

WHEELER & MELICK CO.,
Patentees and Manufacturers of
RAILWAY, CHAIN AND LEVER HORSE POWERS, THRESHERS AND CLEANERS, THRESHERS AND SHAKERS, CLOVER HULLERS, FRED CUTTERS, ITHACA WHEEL HORSE RAKES, HORSE PITCHFORKS, SHINGLE MACHINES, STRAW PRESERVING RYE THRESHERS, &c., &c.



FOUST'S PATENT HAY LOADER, manufactured at the MEADVILLE AG'L WORKS, Meadville, Pa. Warranted to elevate a ton of hay from the winrow to the wagon in five minutes, and take it as clean as by the hand fork, and to be adapted to all ordinary meadow land. Send for Descriptive Circulars.



CHAPMAN'S. The best Fork and Conveyor in use. Recommended by a host of those who have tried it. Saves labor, time, money. Sent on trial. Agents wanted. Circulars sent.
G. B. WEEKS & CO.,
SYRACUSE, N. Y.



This Machine leaves the straw straight and unbroken, when it can again be put into bundles, making it more valuable for market. **WHEELER & MELICK CO.,** Sole Manufacturers, Albany, N. Y. Send for circular.

THE SHAKER THRESHER. A FIRST CLASS SMALL THRESHER.
4 to 6 HORSE LEVER POWER.
WILL THRESH & CLEAN 200-400 BU. WHEAT PER DAY.
CINCINNATI, OHIO.
SEND FOR CIRCULAR.

SELF-ACTING GATES.
NICHOLSON'S PATENT.
The best in the world. Address
AMERICAN GATE CO., Cleveland, O.

ALLEN'S PLANET. 4 STYLES, One just out. The very best Hand Seeders and Cultivators, for Farm or Garden. Light and durable. No equal, Domestic or Imported. Descriptive Circulars of S. L. ALLEN & CO., 119 S. 4th St. Phila., Pa.

The Superior Hay Spreader

(Improved and perfected for season of 1874).

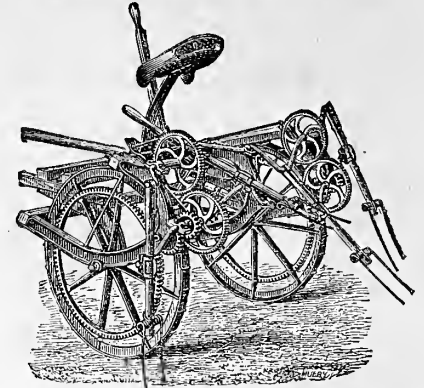

This machine will do the work of ten men. It is the lightest draft machine ever built, one horse working it easily. It has taken first premiums wherever exhibited. Send for a descriptive circular. The Superior Spreader is unsurpassed in beauty, workmanship, and durability. Manufactured by
THE HIGGANUM MANUFACTURING CO.,
Higanum, Conn.

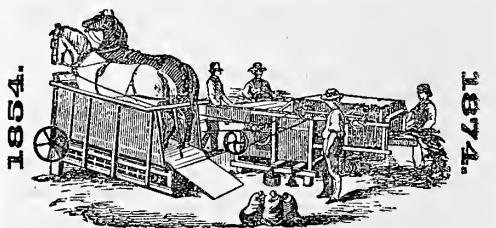

The Peerless Thresher and Cleaner. Price \$225 and \$245. The Peerless, Straw Picking Rye Thresher, Overshot. Price \$160. We make the above a specialty. Railway and Lever Powers.
B. GILL & SON,
Trenton Agricultural Works,
Trenton, N. J.

BUCKEYE DRIER, BAKER AND FEED STEAMER

For full particulars, address
ENGLE, KELLER & CO., Lancaster, Pa.

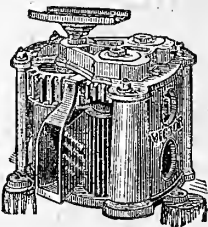

STANDARD Cane Machinery,

For Sorgho and Sugar Cane. The only recognized standards in Cane Machinery are the **COOK EVAPORATOR** AND **VICTOR CANE MILL.** There are of these Machines **Over 31,000 in Use.** They have taken the

FIRST PREMIUMS AT 117 STATE FAIRS. Send for Descriptive Catalogue and Price-List.
BLMYER MANUFACT'G CO., Cincinnati, O. Shaker Thresher, Corn and Cob Crushers, Wood-Sawing Machines, Farm, School, and Church Bells.

Sugar Cane and Sorgho Machinery,

Steam Engines, Horse Powers, Farm Mills etc. Manufactured by
GEO. L. SQUIER & BRO.,
Buffalo, N. Y. Catalogues free.

CABLE FENCING.

Cheap, handsome, and durable. Proof against Cattle fire, and Rust. Hundreds of miles erected. Send for Circulars.
PHILIP S. JUSTICE,
14 North Fifth St., Philadelphia.
42 Cliff St., New York.

BLIND DITCHING FLOW. Can ditch for 1/2 c. per rod. For particulars, address
GEO. CHAMBERLAIN & SON OLEAN, N.Y.

The Simplest,
Strongest,
AND
Easiest Running
Lawn Mowers
MADE

ARE THE
EMPIRE
AND
MONITOR.

Send for circular.
Agents wanted in every
town. Manufactured by
BARLOW & WALKER,
Sing Sing, N. Y.

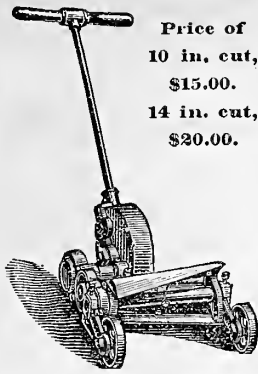

Price of
10 in. cut,
\$15.00.
14 in. cut,
\$20.00.

New Excelsior Lawn Mower.
GREATLY IMPROVED FOR 1874.



It has the Largest Sale of any Lawn Mower
in the World?

It has been adopted, and can be seen in practical operation
on Central Park and all the other City Parks,
New York; Government Grounds and City
Parks, Washington; Boston Common, Boston;
Prospect Park, Brooklyn; and on almost every
prominent Park throughout the United States and
Canada.

Four sizes for hand-power; four sizes for horse-power.
Prices from \$15 to \$200.

EVERY MACHINE WARRANTED.

Address

CHADBORN & COLDWELL M'FG CO.,
Send for Circular. Newburgh, N. Y.

ESTABLISHED 1837.



We offer the above brand of White Lead to the public
with the positive assurance that it is

PERFECTLY PURE.

For sale by dealers generally.

ECKSTEIN, HILLS & CO.,

CINCINNATI, OHIO.

NOTE.—Consumers will consult their INTEREST by
bearing in mind that a large proportion of the article
sold as PURE WHITE LEAD is adulterated to the
extent of from 50 to 90 per cent; and much of it does not
contain a particle of Lead.

50c., \$1, and \$1.50 PER GALLON.

Cottage Color Paints.

Ground in Oil and mixed ready for use. In cans, kegs,
and bbls. Liquid Slate Roof Paint. Cheap, durable, and
fire-proof. Send for cards of Colors and Testimonials.
NEW YORK CITY OIL CO., SOLE AGENTS,
116 Maiden Lane, New York.

The Novelty Lawn Mower and Trimmer.

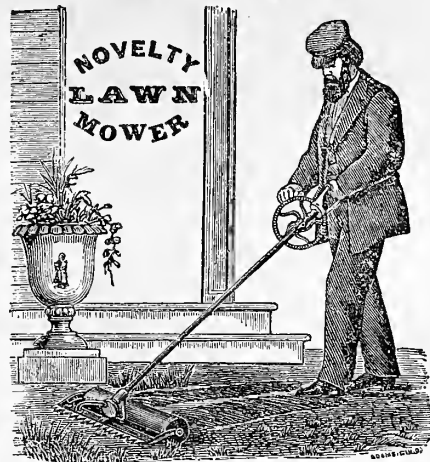

THE
SIMPLEST,
CHEAPEST,
LIGHTEST,
AND BEST.

It has the Only Correct Principle—viz.,
the Field Mower Cut.

It is the Only Lawn Mower that can Cut Long
Grass and do the Trimming.

Does all the Work of a Sickle or Shears.

It is the Lightest Machine in Use, Weighing only
Twenty Pounds. A Child can Work it.

The Construction is so Simple that it
can not get out of Order.

PRICE-LIST.

No. 1.—14-inch Cut.....	\$15.00.
No. 2.—16-inch Cut.....	16.00.
No. 3.—18-inch Cut.....	18.00.
No. 4.—20-inch Cut.....	20.00.

MANUFACTURED BY

CEO. DWIGHT, Jr., & CO.,
Hillman St. Springfield, Mass.

THE PHILADELPHIA LAWN MOWERS. 1874.

Send for Descriptive Circular to
GRAHAM, EMLEN & PASSMORE,
Patentees and Manufacturers, 681 Market St., Philadelphia.

Or to
WHOLESALE AGENTS,
R. H. ALLEN & CO., New York.
WM. E. BARRETT & CO., Providence, R. I.
T. HAWLEY & CO., Bridgeport, Conn.
JOSEPH BRECK & SONS, Boston, Mass.
J. M. CHILDS & CO., Utica, N. Y.
CHAS. E. WALBRIDGE, Buffalo, N. Y.
BOOTH, DOUNCE, ROSE & CO., Elmira, N. Y.

THE FIRST DIVISION OF THE St. Paul & Pacific RAILROAD COMPANY OFFER THEIR LANDS FOR SALE

At moderate prices and on 10 years'
credit, if desired, and also TOWN
LOTS in Towns at R.R. Stations.
They will also sell PRAIRIE LANDS
at low prices on 3½ years' time with-
out interest, provided the purchaser
will make satisfactory improvements.

GOVERNMENT LANDS

Are still to be had under the HOME-
STEAD and TREE CULTURE laws
near the lines of this Company; 240
acres can thus be secured FREE, ex-
cept the regular Land Office entry
fees.

The State of MINNESOTA pays a
bounty of two dollars (\$2) each year
for 10 years, for every acre of trees
planted and cultivated, and two dol-
lars (\$2) per year for 10 years for every
half mile of trees planted and cul-
tivated along an Highway.

For particulars address

HERMANN TROTT,
Land Commissioner, St. Paul, Minn.
EDWARD D. ATWATER, Secretary.

NANSEMOND SWEET-POTATO
PLANTS. May and June. Best for the northern
climate. Packed to carry long distances. By mail, pre-
paid, 60 cts. per 100. By express, \$3 per 1,000. Discount on
large orders. Address
S. GRAY Norwalk, Huron Co., Ohio.

JULIEN CHURN.

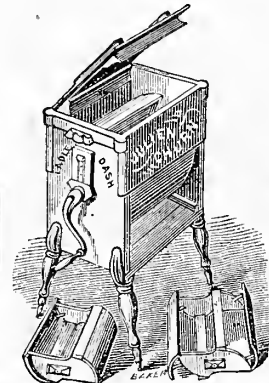

Sold from the Atlantic
to the Pacific.

The best Churn in the
market, and so war-
ranted.

Send for Butter-Mak-
ers' Manual.

Wholesale Agents:

H. B. GRIFFING,
Cortlandt St., New York.
WOODFORD & CHAMBER-
LAIN, Cleveland, O.

L. J. RUSH & Co.,
Milwaukee, Wis.
SAMUEL CUPPLES & Co.,
St. Louis, Mo.

W. C. CHAMBERLAIN,
Dubuque, Iowa.

Established 1858.



TRADE MARK PATENTED.

The best and cheapest Paint in the
world for Iron, Tin or Wood. For sale by
the Trade everywhere. PRINCE'S METALLIC
PAINT CO., Manufacturers, 96 Cedar St., New York.

CAUTION.—Purchasers and consumers are cau-
tioned against imitations of our METALLIC PAINT.
All genuine PRINCE'S METALLIC PAINT will
bear our name and trade mark on each and every
package. Send for a circular.

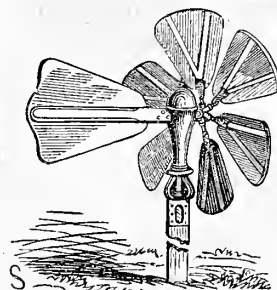

Automatic PUMPS.

Water driven to any
height and distance by
compressed air. Coun-
try houses supplied
cheaply and certainly
for bath-rooms, water
closets, hot and cold
water faucets, etc.
Plenty of fresh water
for stock on farms.

Address
HARTFORD PUMP CO.,
41 Trumbull St.,
Hartford, Conn.

Mix's Banner Windmill
has proved itself the most reliable and perfect WIND POWER
in use. Each mill warranted. Circulars free. Agents
wanted. HOCKING VALLEY M'FG Co., Lancaster, Ohio.

BOOKS ON ARCHITECTURE.

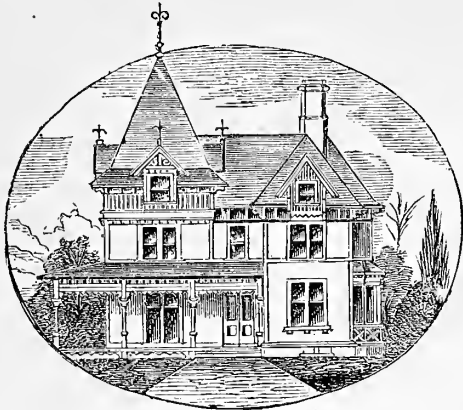

A Practical Book, one that Architects, Builders, and Carpenters can not afford to be without, entitled

DETAIL, COTTAGE, AND CONSTRUCTIVE ARCHITECTURE,

Containing 76 FULL PLATES, 20 plates more than before offered in a similar work for Ten Dollars.

Published under the direction of A. J. BICKNELL.

Showing a great variety of Designs for Cornices, Brackets, Windows and Window Caps, Doors, Piazzas, Porches, Bay and Dormer Windows, Observatories, Towers, Chimney Tops, Balconies, Canopies, Serolls, Gable and Sawed ornaments, Fences, Stairs, Newels, Architraves, Mantels, Plaster Finish, etc., etc.; including Forty-five Perspectives, Elevations and Plans of Modern Designs for Cottages with Details, and Eighteen Elevations of Summer Houses, Villas, Seaside Cottages, and Country Houses, together with Fourteen Designs for Street and Store Fronts, with Inside Finish for Stores and Banks; also, Framing for Dwellings, Barns, Exhibition Buildings, Roofs, Bridges, etc., etc., making in all a Practical Book for Architects, Builders, Carpenters, and all who contemplate Building or Remodeling Wood, Stone, or Brick Buildings. One Large Quarto Volume, sent Free by Mail or Express, on receipt of Price.....\$10.00.

Bicknell's Village Builder, And SUPPLEMENT.

THE VILLAGE BUILDER shows Elevations and Plans for Cottages, Villas, Suburban Residences, Farm Houses, Stables and Carriage-Houses, Store Fronts, School-Houses, Churches, Court-Houses, and a Modern Jail. Also, Exterior and Interior Details for Public and Private Buildings, with approved Forms for Contracts and Specifications, containing fifty-five Plates, drawn to Scale, giving the Style and Cost of Building in different sections of the Country. Revised Edition, with three additional Plates, showing inside finish for Stores, Banks, and Insurance Offices, and two Elevations and Plans for low-priced Dwellings; also, a variety of Details added to several Plates. Quarto Volume, issued February 1, 1872. The SUPPLEMENT contains Twenty Plates, showing Eighteen Modern and Practical Designs for Country and Suburban Residences of moderate cost, with Elevations, Plans, Sections, and a Variety of Details, all Drawn to Scale. Also, a Full Set of Specifications, with Approved Form of Contract and Estimates of Cost. The Two Books in one Volume, price\$12.00. Parties desiring the Supplement only, will be supplied, post-paid, on receipt of \$5.00.

ARCHITECTURE.

By CUMMINGS & MILLER.

A Practical Book on Architectural details, containing over One Thousand Designs and Illustrations, showing the manner of constructing Cornices, Doorways, Porches, Windows, Verandas, Railings, French Roofs, Observatories, Piazzas, Bay-Windows, Cut-Stone Work, various styles of Modern Finish, and Street Fronts of Houses, Stores, etc., etc. One Large Quarto Volume. Price, post-paid.....\$10.00.

Modern American Architecture.

By CUMMINGS & MILLER.

Containing Designs and Plans for Villas, Farm-Houses, School-Houses, Cottages, City Residences, Churches, etc. Also, Trussed Roofs, Interior Store Finish, and many Exterior Details. In One Large Volume, bound in Cloth, 54 Plates, price.....\$10.00.

Loth's Practical Stair-BUILDER.

A complete Treatise on the Art of Building Stairs and Hand-Rails. Designed for Carpenters, Builders, and Stair-Builders. Illustrated with Thirty Original Plates. By C. EDWARD LOTH, Professional Stair-BUILDER. One large Quarto Volume. Bound in Cloth. Price.....\$10.00.

Address

ORANGE JUDD COMPANY,
245 BROADWAY, NEW YORK.

WHOLESALE PRICE-LIST.

CRANDALL'S IMPROVED BUILDING - BLOCKS FOR CHILDREN.



BEAUTIFUL, AMUSING, INSTRUCTIVE.

CRANDALL'S Building - Blocks.

PRICE PER DOZEN BOXES.

- No. 1, \$12.00 (3 Dozen Boxes in a Case).
- No. 3, \$ 6.00 (6 Dozen Boxes in a Case).
- No. 4, \$ 6.00 (6 Dozen Boxes in a Case).

CRANDALL'S Masquerade - Blocks.

Price per Dozen Boxes \$6.00 (6 Dozen Boxes in a Case).

CRANDALL'S Expression - Blocks.

Price per Dozen Boxes, \$3.00 (12 Dozen Boxes in a Case).

Crandall's Acrobats.

Price per Dozen Boxes, \$8.00 (6 Dozen Boxes in a Case).

CRANDALL'S Alphabet-Blocks,

Red White and Blue.

Price per Dozen Boxes, \$6.00 (6 Dozen Boxes in a Case).

Orders from the trade will be supplied on liberal terms.

MANUFACTURED BY
C. M. CRANDALL & CO.

ORANGE JUDD COMPANY,
Sole Agents,
245 BROADWAY, NEW YORK.

"UP FOR REPAIRS,"

A Beautiful, New Picture for Every Subscriber to the

American Agriculturist

FOR 1874.

An exquisite Oil Painting by the celebrated American Painter, Mr. B. F. Reinhart, executed expressly for the *American Agriculturist* and entitled

"UP FOR REPAIRS,"

has been most successfully reproduced in Chromo by the well-known firm of Beneke & Scott. It is a picture of a scene in childhood, which many will recognize as what they have themselves witnessed or been actors in, and can not fail to please both old and young.

The Publishers will give this beautiful Chromo

To Every Subscriber

to this paper for the year 1874 received after this date, as detailed below. It is ready for immediate delivery at 245 Broadway, Free of Charge.

If to go by mail, 10 cents must be sent to cover cost of packing and postage. For 25 cents it will be Mounted, Varnished, Packed, and sent Post-paid.

N. B.—The Chromo will be delivered:

- At the Office, **Umounted**, Free.
- " " **Mounted**, 15 cents extra.
- Sent by Mail, **Umounted**, 10 cents extra.
- " " **Mounted**, 25 cents extra.

We advise all to have them mounted before leaving the office, as in the large quantities we put up we are able to mount them for a quarter of the cost of doing it singly, and better than it can usually be done elsewhere.

The picture is designed for every subscriber upon the terms stated above, which please read carefully; and on these terms all are alike entitled to it, whether their names come singly at \$1.50 each, or in Clubs of Four for \$5, or Clubs of Ten at \$1.20 each, or in Clubs of Twenty or more at \$1 each. Subscribers in Premium Clubs will also thus be entitled to it.

N. B.—A few of the beautiful pictures entitled "MISCHIEF BREWING," which have been given to so large a number of subscribers, are still in stock, and, while any remain, subscribers to the *American Agriculturist* can have their choice between this and the new Chromo "UP FOR REPAIRS"; but the choice must be named at time of subscribing. ORANGE JUDD COMPANY,

245 BROADWAY, NEW YORK.

BEAUTIFYING COUNTRY HOMES.

AN ELEGANT QUARTO VOLUME.

By J. WEIDENMANN.

PRICE, POST-PAID, \$15.00.

This magnificent work is illustrated not only with numerous fine wood-engravings, but also with seventeen full-page and seven double-page colored lithographs of places already improved. It embodies the results of a long practice in landscape architecture and rural adornment, and while its teachings are in accordance with the received rules of art, they are thoroughly practical in their character. It is one of the most elegant, and ought to prove one of the most useful works ever issued in the country. The work, both in its letter-press and colored lithographs, is beautifully printed, and it is elegantly bound in beveled boards.



Hussey's National Cottage Architecture.

New and Original Designs, Working Scale Drawings, and Details for all Styles of low-priced Houses, with Specifications and Cost. Just published. Royal quarto. Post-paid, \$6.

WOODWARD'S NATIONAL ARCHITECT. } 1,000 WORKING DRAWINGS, Plans, Details, Specifications, and Estimates. TWELVE DOLLARS, post-paid.

MONCKTON'S NATIONAL STAIRBUIDER. } SIX DOLLARS, post-paid.

MONCKTON'S NATIONAL CARPENTER and JOINER. } SIX DOLLARS, post-paid.

Either of the above books sent post-paid on receipt of price by

Orange Judd Company, 245 Broadway, N. Y.

Beckwith Sewing Machines \$12 and \$20.

We have offered as a Premium, and also for sale, for more than a year past, the Beckwith Sewing Machine, which has been fully described in previous numbers of this paper.

We still offer the Beckwith Sewing Machine, Improved, price \$12. A new and very simple braiding-foot has been made, by which a child can sew on braid without the least trouble, following any desired pattern with ease;

Each of these machines is put in a neat, compact box, with hemmer and guide, oil-can with oil, thread, different-sized needles, etc., with full Printed Directions for using.

The Machine as a Premium.

We will give one of these \$12 machines to any one who will collect and forward eight subscribers for Hearth and Home one year at \$3 each; or sixteen subscribers to American Agriculturist for one year, at \$1.50 each.

THE BECKWITH PORTABLE FAMILY SEWING MACHINE.

PRICE \$20.

Enlarged and Improved. Its Weight is 7 Pounds.

While we continue the offer of the Improved \$12 Machine as heretofore, we now offer the new

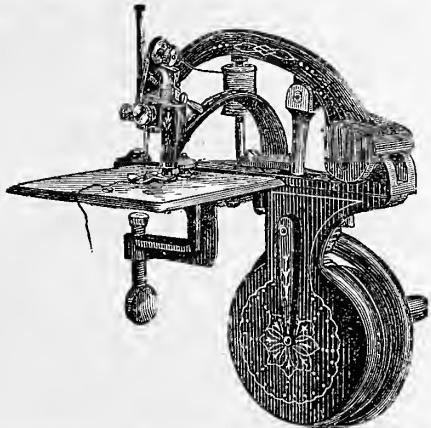

PORTABLE FAMILY MACHINE,

price \$20, which comprises all the excellencies of the former, with many valuable improvements. Its size and power are increased, and its capacity thus very much enlarged, without impairing its portability.

To any one sending us \$20, we will send one of the Machines (packed in a neat, portable case, with handle to carry it easily), expressage to be paid by purchaser.

The Machine as a Premium.

We will give one of these \$20 Machines to any one who will collect and forward to us Fifteen Subscribers to Hearth and Home for one year at \$3 each, or Thirty Subscribers to American Agriculturist for one year at \$1.50 each, or One Hundred at \$1 each, expressage on the Machine to be paid by the recipient of it.

Almost any lady can readily secure the small number of subscribers required to get either the \$12 or the \$20 Machine as described above; or some friend can thus obtain it for her as a present.

ORANGE JUDD COMPANY, 245 BROADWAY, NEW YORK.

DO GOOD AND MAKE MONEY.

The Publishers of American Agriculturist and HEARTH AND HOME take pleasure in presenting in the adjoining Table, their new general Premium List for 1874. The Premiums which they have offered in past years have engaged the attention of a very large number of persons of all ages and both sexes.

Here is pleasant and profitable work for all. Any one who wishes to do good and make money, can do both by going to work as here invited by the publishers of these two most valuable journals, American Agriculturist and HEARTH AND HOME.

Explanatory Notes.

N. B.

Read and carefully

Note the following Items: (a) All subscribers sent by one person count, though from one or a dozen different Post-offices. But... (b) Tell us with each name or list of names sent, that it is for a premium... (c) Send the names as fast as obtained, that the subscribers may begin to receive the paper at once.

[In the following table is given the price of each article, and the number of subscribers required to get it free, at the regular rates, \$1.50 a year for American Agriculturist, and \$3.00 a year for Hearth and Home; also at the club rates of \$1 and \$2.50; also at the rates of \$4 a year for both papers together.]

N. B.—In all Premium Clubs for either paper, TWO copies of American Agriculturist (English or German) at \$1.50 each, and ONE copy of Hearth and Home at \$3.00, will count exactly the same.

Table of Premiums and Terms for American Agriculturist, and for Hearth and Home, for the Year 1874. Includes columns for article names, prices, and subscriber requirements.

Every Premium article is new and of the very best manufacture. No charge is made for packing or boxing any article in our Premium List. The Premiums, Nos. 2 to 8, 27 to 33, 55 to 78, and 81 to 93, inclusive, will each be delivered FREE of all charges, by mail or express.

GREAT DEDUCTION. TEAS and COFFEES

At Wholesale Prices. Increased Facilities to Club Organizers. Send for New Price-List. THE GREAT AMERICAN TEA COMPANY, (P. O. Box 5643.) 31 and 33 Vesey St., New York.

WOOD, TABER & MORSE, Eaton, Madison Co., N. Y.

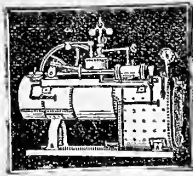

MANUFACTURERS OF Steam-Engines, Portable, Stationary, and Agricultural.

Hundreds in use in Shops, Printing Rooms, Mills, Mines, and on Farms and Plantations for Grain Threshing, Food Cooking for Stock, Cotton Ginning, Sawing, etc. Circulars sent on application.

HO! FOR IOWA

HOUSES, at \$5 and \$6 per acre, on long time. Over 1,500,000 acres Railroad Lands, free from mortgage, for sale by the Iowa Railroad Land Co., all on the C. & N. W. & Ill. Central Railway lines, in the middle region of Western Iowa, the richest farming belt in the West. Pure water abundant. No fever and ague. Send for a land guide. It costs nothing, and gives every useful information. Address

JOHN B. CALHOUN, Land Commissioner,

90 Randolph Street, Chicago, or Cedar Rapids, Iowa

The Fleetwood Scroll Saw.

For all description of light Scroll or Fret Sawing in Wood, Bone, Shell, or Metal. Just the thing for making Parlor Ornaments, Brackets, Picture Frames, Monograms, etc.

The Best Machine for the Price Ever Made. Price \$10 and \$15.

Hundreds of extravagant testimonials. See full description in Am. Agriculturist, November, 1873, pages 409 and 432. Send for illustrated circular and list of designs.

TRUMP BROS., Wilmington, Del.



LOVEJOY'S METALLIC WEATHER HOUSES

Indicate the changes in the weather, and are pretty mantel ornaments. The little lady appears in fair and the man in stormy weather, and they never make mistakes. Sent prepaid to any address, safely packed, upon receipt of \$2 (Two), by

ALVAN L. LOVEJOY, Proprietor and Manufacturer, 229 Washington St. Boston.

Special price to dealers.

JAS. T. ALLEN & CO.

Have manufactured a large stock of

RICH AND MEDIUM PRICED

FURNITURE

for the spring trade, which is now on exhibition and for sale, at wholesale and retail, at their extensive

WAREROOMS,

185 & 187 CANAL ST., NEW YORK.



Improved Foot Lathes.

Small Engine Lathes, Small Gear Cutters, Hand Planers for Metal, Ball Turning Machines, Slide Rests, Foot Scroll Saws. The very best. Selling everywhere. Catalogues free.

N. H. BALDWIN, Laconia, N. H.

Just the articles for Artisans or Amateurs.

FIRST Premiums awarded by Amer. Inst., 1870.

MICROSCOPES.

Illustrated Price-List sent free on application.

MAGIC LANTERNS.

Catalogue, priced and illustrated, sent free.

T. H. McALLISTER, Optician, 49 Nassau-st., N. Y.

PRESERVE YOUR STOVES from Rust by polishing them with GEM STOVE POLISH before putting them away for the summer.

THE HOOSIER SCHOOL-MASTER.

By EDWARD EGGLESTON. Finely Illustrated, with 12 Full-Page Engravings, and Numerous Other Cuts.

NOTICES BY THE PRESS.

It is full of quaint humor, a tender pathos, and vivid descriptions.—New York Standard.

The "events" are stirring and dramatic, and the style is quiet, impersonal, and almost epigrammatic in its ability to lay bare an entire situation or character in a sentence or phrase.—Brooklyn Daily Eagle.

It is at once quaint and truthful, and illustrated as it is by masterly cuts, it should be one of the most popular books.—Christian Standard (Cincinnati).

For realistic conception and life-like delineation of character, it is not excelled by any American story.—Methodist. Some passages in it, for life-like delineation and the simple, artless beauty which constitute the highest perfection of story-writing, are equal to some of the very best passages in Dickens.—Religious Telescope.

PRICE, POST-PAID.....\$1.25.

The End of the World.

A LOVE STORY.

By EDWARD EGGLESTON,

Author of "The Hoosier School-Master."

WITH

Thirty-two Fine Illustrations.

NOTICES BY THE PRESS.

The personages who figure in this story are, with one exception, country people—such men and women as Wordsworth loved to study. It is not every man, whatever may be his talents, that can safely enter this sphere of literary labor. To be successful in it, he must possess exceptional qualities; but for those who know how to find it, here there is gold of the purest, richest kind. In such a work, however, there is no convenient place where mediocrity can rest; there is nothing but absolute failure or absolute success. And Mr. Eggleston has succeeded. His power lies in the delineation of character. The plot is ingenious and natural, the incidents are managed with great skill, and there are many descriptive passages of singular force and beauty. But the strongest impression left on the reader's mind as he closes the volume is that he has been in the company of very interesting men and women, and has made a number of new and valuable acquaintances.—The Albion, New York.

Price, Post-paid, \$1.50.

The Mystery

OF

Metropolisville,

By EDWARD EGGLESTON,

Author of "The Hoosier School-Master," "The End of the World," etc.

FINELY ILLUSTRATED.

CONTENTS.

Preface.—Words Beforehand. Chapter 1, The Autocrat of the Stage-Coach.—2. The Sod Tavern.—3. Land and Love.—4. Albert and Katy.—5. Corner-Lots.—6. Little Katy's Lover.—7. Catching and Getting Caught.—8. Isabel Marlay.—9. Lovers and Lovers.—10. Plausaby, Esq., takes a Fatherly Interest.—11. About Several Things.—12. An Adventure.—13. A Shelter.—14. The Inhabitant.—15. An Episode.—16. The Return.—17. Sawney and his Old Love.—18. A Collision.—19. Standing Guard in Vain.—20. Sawney and Westcott.—21. Rowing.—22. Sailing.—23. Sinking.—24. Dragging.—25. Afterwards.—26. The Mystery.—27. The Arrest.—28. The Tompter.—29. The Trial.—30. The Penitentiary.—31. Mr. Lurton.—32. A Confession.—33. Death.—34. Mr. Lurton's Courtship.—35. Unbarred.—36. Isabel.—37. The Last.—Words Afterwards.

ILLUSTRATIONS.—By FRANK BEARD.

His Unselfish Love found a Melancholy Recompense.—The Superior Being.—Mr. Minorkey and the Fat Gentleman.—Plausaby sells Lots.—"By George! He! he! he!"—Mrs. Plausaby.—The Inhabitant.—A Pinch of Snuff.—Mrs. Ferrer.—One Savage Blow full in the Face.—"What on Alth's the Matter?"—The Editor of "The Windmill."—"Git up and Foller!"

Price Postpaid - - - - \$1.50

Either of the above books sent post-paid on receipt of price, by the

ORANGE JUDD COMPANY, 245 BROADWAY, NEW YORK.

A Man of Honor.

By GEORGE CARY EGGLESTON. Finely Illustrated.

The publishers take pleasure in commending this as one of the most charming stories that has been presented to the American people. Mr. Eggleston has given to it, with rare fidelity, the local coloring of the part of the country where its scenes are laid. It is a realistic story of life in the Old Dominion. Its people are ladies and gentlemen. Robert Pagebrook, the "Man of Honor," is every inch a man, and his sayings and doings at once attract and hold the reader's attentive interest. It is a love-story, too, and has the merit, which is not as common as it might be nowadays, of ending to the reader's entire satisfaction.

NOTICES BY THE PRESS.

A capital picture of Life in Old Virginia before the war is to be found in Mr. George Cary Eggleston's "A Man of Honor." Virginian hospitality, Virginian cousinship, Virginian housekeeping, are portrayed in accurate and attractive colors. It is a life which the author has himself known and loved, and he writes of it with a warmth that comes from the heart.—N. Y. Evening Post.

Really readable in the most refreshing sense of the term—a story of the most amusing and attractive interest.—St. Louis Times.

It is written in an off-hand manner, and is bright and amusing.—Worcester, Mass., Spy.

With Virginian life as a specialty, Mr. Eggleston has drawn a simple, straightforward, truthful, and withal, artistic picture of Southern society. It is sketchy, perhaps too much so, but the sketches are all vigorous and show the hand of a practiced artist. In forming the characters of his book it is evident that Mr. Eggleston has drawn oftener on his memory than on his imagination; that he has lived among the people whom he describes, has heard them talk, and seen them under all the moods of ordinary life.—Boston Daily Advertiser.

CONTENTS.

Chapter 1. Mr. Pagebrook gets up and calls an Ancient Lawgiver.—2. Mr. Pagebrook is Invited to Breakfast.—3. Mr. Pagebrook Eats his Breakfast.—4. Mr. Pagebrook Learns Something about the Customs of the Country.—5. Mr. Pagebrook Makes some Acquaintances.—6. Mr. Pagebrook Makes a Good Impression.—7. Mr. Pagebrook Learns Several Things.—8. Miss Sudie Gets an Apt Quotation.—9. Mr. Pagebrook Meets an Acquaintance.—10. Chiefly Concerning "Foggy."—11. Mr. Pagebrook Rides.—12. Mr. Pagebrook Dines with his Cousin Sarah Ann.—13. Concerning the Rivulets of Blue Blood.—14. Mr. Pagebrook Manages to be in at the Death.—15. Some very Unreasonable Conduct.—16. What Occurred Next Morning.—17. In which Mr. Pagebrook Bids his Friends Good-by.—18. Mr. Pagebrook Goes to Work.—19. A Short Chapter, not very interesting, perhaps, but of some importance in the Story, as the Reader will probably Discover after awhile.—20. Cousin Sarah Ann Takes Robert's Part.—21. Miss Barksdale Expresses some Opinions.—22. Mr. Sharp Does his Duty.—23. Mr. Pagebrook Takes a Lesson in the Law.—24. Mr. Pagebrook Cuts Himself Loose from the Past and Plans a Future.—25. In which Miss Sudie Acts very Unreasonably.—26. In which Miss Sudie adopts the Socratic Method.—27. Mr. Pagebrook Accepts an Invitation to Lunch and Another Invitation.—28. Major Pagebrook Asserts Himself.—29. Mr. Barksdale the Younger goes upon a Journey.—30. The Younger Mr. Barksdale Asks to be Put upon his Oath.—31. Mr. William Barksdale Explains.—32. Which is also the Last.

ILLUSTRATIONS.—By M. WOOLF.

"Now I've Got You" (Frontispiece).—Mr. Robert Pagebrook was "Blne."—"I Fall at Once into a Chronic State of Washing up Things."—"Foggy."—Cousin Sarah Ann.—The Rivulets of Blue Blood.—Miss Sudie Declares Herself "so Glad."—"Let Him Serve it at Once, Then."—"Very Well, Then."—"I'm as Proud and as Glad as a Boy with Red Morocco Tops to his Boots!"

PRICE, POST-PAID.....\$1.25

ORANGE JUDD COMPANY, 245 BROADWAY, NEW YORK.

WANTED.—The United States Life Insurance Company is now reorganizing its Agency Department, and is prepared to negotiate with gentlemen of business ability to act as Agents. Previous connection with the business is not considered necessary. Apply at the Home Office, 261 Broadway, New York. JOHN E. DEWITT, President.

IN PRESS.

READY THIS MONTH.

A New and Revised Edition of Peter Henderson's well-known Work,

Gardening for Profit.

A Guide to the Successful Cultivation of the Market and Family Garden.

By PETER HENDERSON.

Finely Illustrated. Price, Post-paid, \$1.50.

The following voluntary notice of this work comes from a Western market gardener and shipper of vegetables, and is a specimen of similar testimony from very many quarters.

March 23d, 1874.

"If this should go to Mr. Henderson, I would say that I believe the gardeners of this country would gladly hail another edition of 'Gardening for Profit;' at least, I thank him for that little work. Through its influence I left a paying manufacturing business and began to follow its teachings. This was three years ago. Now I have a market garden of thirty acres and 400 four-foot sash, and enjoy myself as I never did before. Again I thank him."

ORANGE JUDD COMPANY, 245 BROADWAY, NEW YORK.

JUST PUBLISHED.

JOHN ANDROSS.

BY

REBECCA HARDING DAVIS,

Author of "Life in the Iron Mills," "Dallas Galbraith," etc., etc.

ILLUSTRATED.

The genius of George Eliot finds not only a peer, but a counterpoint in that of Mrs. Rebecca Harding Davis. The resemblance between these two seems a growing one, and as "John Andross" unfolds itself more and more, the points of similarity between it and the best of George Eliot's work become more and more strongly marked. Not that "John Andross" is in any sense an imitation, or its author in any sense an imitator. The similarity is not sameness; the resemblance is by no means a likeness. In "John Andross" we find the same boldness of touch, the same consciousness of strength, that delight us in every page of "Middlemarch." The two authors are alike in the confidence with which they discard all models and become a law unto themselves. There is no resemblance whatever between the people created by the one and those who serve the purposes of the other, except that the personages of each are undoubted originals always. The machinery by which Mrs. Davis brings her people before us, and shows us what manner of men they are, is totally unlike that which George Eliot uses, and their plots resemble each other in nothing except in their utter unlikeness to any others in the world, their entire originality, and their unusual fitness to serve the ends for which they are created.

Another point of resemblance between the two writers is the masterly knowledge each seems to have, from first to last, of the peculiarities of character which underlie the actions of her people. The weakness of Andross's chin is as necessary a part of him as the chin itself is. His irresolution; his honesty of purpose, and his inability to make it honestly of practice; his desire for good, and his choice of evil; his sudden elevations and depressions of spirit; his vacillation; all these and the character of which they are born are open secrets to Mrs. Davis. She makes no analysis of character, and tells us nothing about the mental and moral muscles which her personages bring into play. She simply holds her lens before our eyes, and her people become transparent. We see for ourselves how they are made up, and we see the several parts in actual play before us.

Price, Post-paid, \$1.50.

ORANGE JUDD COMPANY, 245 BROADWAY, NEW YORK.

BOOKS for FARMERS and OTHERS.

[Published and for sale by the Orange Judd Company, 245 Broadway, New York. Any of these books will be forwarded by mail, post-paid, on receipt of price.]

Table listing various agricultural books such as 'Allen's (L. F.) American Cattle', 'Allen's (L. F.) Rural Architecture', 'Allen's (L. L.) American Farm Book', etc., with prices.

Table listing various agricultural books such as 'Youatt and Martin on Cattle', 'Youatt on the Hog', 'Youatt on Sheep', 'O. J. Co. keep in Stock the following Books', etc., with prices.

FRAMES FOR THE CHROMOS.

We have made arrangements to supply frames to our subscribers who may desire them for the Chromos which are now being distributed. Many will no doubt avail themselves of this opportunity to place these beautiful pictures in handsome frames at moderate cost. In all cases where sent by express, the purchaser will pay express charges. The prices of the frames are as follows:

For American Agriculturist Chromo, "UP FOR REPAIRS," Or for Hearth and Home Chromo, "LOOK OUT!"

Table listing prices for 'Letter A. Neat Black-Walnut Frame, Gilt Band', 'Letter D. Full Gilt Frame, 2 inches wide', etc.

For American Agriculturist Chromo, "MISCHIEF BREWING."

Table listing prices for 'No. 1. Neat Black-Walnut Frame, Gilt Band', 'No. 4. Full Gilt Frame, 2 inches wide', etc.

For Hearth and Home Chromo, "THE STRAWBERRY GIRL."

Table listing prices for 'No. 8. Neat Black-Walnut Frame, Gilt Band', 'No. 11. Full Gilt Frame 2 inches wide', etc.

Address orders, specifying by its letter or number the frame desired, and inclosing price, as above, to the

ORANGE JUDD COMPANY, 245 BROADWAY, NEW YORK.



**BABCOCK
FIRE
Apparatus,**
ENGINES,
EXTINGUISHERS,
TRUCKS, etc.

BABCOCK MANUFACTURING CO.,
407 Broadway, New York,
83 Washington Street, Chicago.

Play and Profit IN MY GARDEN.

By **E. P. ROE,**

Author of "Barriers Burned Away," etc.

NOTICES BY THE PRESS.

The author takes us to his garden on the rocky hill-sides in the vicinity of West Point and shows us how out of it, after four years' experience, he evoked a profit of \$1,000, and this while carrying on pastoral and literary labors. . . . It is very rare that so much literary taste and skill are mated to so much agricultural experience and practical good sense.—*Harper's Magazine.*

This book is as poetical as it is practical. Still he is no dreamer. He goes into every essential detail with as much minuteness and precision as if he were writing a manual for the practical farmer. Indeed few works professedly devoted to agriculture give more sound and valuable information on the secret of winning golden harvests from the soil than this brief idyllic sketch.—*N. Y. Tribune.*

A very charming book, not only by reason of its pleasant style, but for its quiet refined humor and fund of really useful information on the subject of gardening.—*Boston Gazette.*

It deserves to stand side by side with "My Summer in a Garden."—*Christian Register.*

A fresh, lively work.—*N. Y. Observer.*

One reads without weariness and learns much of practical value.—*Chicago Evening Journal.*

Full of information. Explains just what the reader wishes to know. We most heartily commend it.—*Providence Evening Press.*

A chaty, sensible, profitable book.—*Cleveland Herald.*

The book gives much valuable information, and gives it in the pleasantest manner imaginable.—*Detroit Daily Union.*

CONTENTS.

- | | |
|---|---|
| CHAP. 1.—Why you Walk into my Garden? | CHAP. 10.—When to Commence a Garden. |
| 2.—My Garden Accounted for. | 11.—We will go to Work. |
| 3.—My Garden—Its Location. | 12.—The Campaign in September. |
| 4.—My Garden—How it Grew. | 13.—Preparing for Winter Quarters. |
| 5.—My Garden—What Fruits were Cultivated. | 14.—Gardening Over a Winter Fire. |
| 6.—The Same—Continued. | 15.—April. |
| 7.—Markets. | 16.—Grafting or Horticultural Conversion. |
| 8.—Expenses. | 17.—Corn and Beans (Succession). |
| 9.—Ground for a Garden. | |

Price, Postpaid \$1 50

Money IN THE GARDEN.

A VEGETABLE MANUAL,
PREPARED WITH A VIEW TO
ECONOMY AND PROFIT,
BY P. T. QUINN,
PRACTICAL HORTICULTURIST.

In this work the author aims to give, in a plain, practical style, instructions on three distinct although closely connected branches of gardening—the kitchen-garden, market-garden, and field culture; the only and sufficient credentials for the fitness of his undertaking being a successful practical experience for a term of years.

CONTENTS.

- | | |
|---------------------------------|----------------------------|
| Chapter I. Money in the Garden. | Chapter VIII. Melons. |
| " II. Hot-beds. | " IX. Onions. |
| " III. Artichoke. | " X. Parsley. |
| " IV. Beans. | " XI. Radishes. |
| " V. Cabbages. | " XII. Salsify. |
| " VI. Egg-Plants. | " XIII. Tomatoes. |
| " VII. Lettuce. | " XIV. Potatoes Houses. |
| | Chapter XV. List of Seeds. |

PRICE, POST-PAID \$1 50

Either of the above books sent post-paid on receipt of price by

ORANGE JUDD COMPANY,
245 BROADWAY, NEW YORK.

DON'T FAIL TO HAVE A LIBRARY. GOOD BOOKS For Farmers' Libraries.

In response to a request made of one whose thorough and practical knowledge on all matters pertaining to the Farm, Garden, and Household is so fully conceded that his opinions could not fail to secure attention and command respect were we permitted to give his name, we have received the following as his judgment concerning some of the works on our Catalogue of Books for Farmers.

Any of these Books will be forwarded, post-paid, to any address in the United States or Territories, on receipt of the price, by Orange Judd Company, 245 Broadway, New York.

For a Farmer's Library.

How Crops Grow,

(price \$2.00), and

How Crops Feed,

(price \$2.00.)

By Prof. SAM'L W. JOHNSON.

If I could have but two books in such a library it would be these, as I consider them the most important contributions to agricultural literature of modern times. They contain all of vegetable physiology and agricultural chemistry that any except special students need, and nowhere is there so much of agriculture condensed in so small a space. As works of reference they are indispensable.

Most farming operations are accomplished by force, applied through implements and machines, and a farmer should understand mechanics, at least sufficiently to apply force most economically. In this work the fundamental principles are clearly taught, and their application illustrated.

This is the best American work upon general farm management. It treats of the leading crops, buildings, draining, etc., and includes sufficient about animals of different kinds to meet the wants of most farmers.

For the farmer who wishes to know something about the weeds upon his farm, as well as useful cultivated and wild plants, this will answer better than a general treatise on botany.

Such a library should have some work on domestic architecture. Most works upon the subject are costly on account of the designs. This is one of the best works, at a moderate price, and contains, with other matter, the method of building with concrete.

After the farm crops, fruit is of the most importance. No work covers the whole subject so completely as this.

Farms near cities often make more from garden crops than from farm crops. This is the best work on market gardening, and will serve for the family garden also.

An excellent garden book, and in the libraries for Southern farmers might be substituted for Henderson's, but it would be well to have both.

I do not know of any book upon out-door flower gardening that on the whole is so good as this. Its teachings are sound, and style pleasing.

Country and Suburban Homes.

By D. T. ATWOOD.

Price \$1.50.

The Fruit Garden.

By P. BARRY. Price \$2.50.

Gardening for Profit.

By PETER HENDERSON.

Price \$1.50.

Gardening for the South.

By WM. N. WHITE.

Price \$2.00.

The New Book of Flowers.

By JOSEPH BRECK.

Price \$1.75.

Mysteries of Bee-Keeping.

By M. QUINBY. Price \$1.50.

Practical Poultry-Keeper.

By L. WRIGHT. Price \$2.00.

The Pig.

By JOSEPH HARRIS.

Price \$1.50.

Draining for Profit.

By GEO. E. WARING, JR.

Price \$1.50.

Dairy Husbandry.

By X. A. WILLARD.

Price \$3.00.

Tim Bunker Papers.

Price \$1.50.

Bees, Poultry, and Pigs are often made subjects of especial care by small farmers, and separate treatises on these are more likely to be asked for in a library like this than those upon the larger animals. Each of these is the best in its line.

So in farm operations, those of Draining and Dairying, especially the factory system, are not likely to be treated sufficiently in detail in general works.

As all the other works are matters of fact, it may be well to have a little pleasantry. This conveys much sound teaching on rural economy in a quaint style, and it is sometimes policy to sugar-coat your pill.

Books for a Larger Library.

Besides all the works in the foregoing list, I would add the following:

American Cattle. L. F. ALLEN. \$2.50.

Randall's Sheep Husbandry. \$1.50.

Hints to Horse Keepers. H. W. HERBERT. \$1.75.

American Cattle Doctor. G. H. DADD. \$1.50.

Insects Injurious to Vegetation.

DR. HARRIS. \$4.00.

Fruits and Fruit Trees of America.

DOWNING. \$5.00.

Cranberry Culture. J. J. WHITE. \$1.25.

Grape Culturist. A. S. FULLER. \$1.50. (For the West would substitute Hensman's Grapes and Wine. \$1.50.)

Grasses and Forage Plants.

C. L. FLINT. \$2.50.

Forest Trees. ARTHUR BRYANT. \$1.50.

Landscape Gardening. KEMP. \$2.50.

Hops, 40 cts. **Flax,** 50 cts. **Tobacco,** 25 cts.

Onion, 20 cts. Essays.

Boussingault's Rural Economy. \$1.60.

Play and Profit in My Garden. ROE. \$1.50.

Window Gardening. WILLIAMS. \$1.50.

Books for a Still Larger Library.

In addition to those mentioned in the other two lists, I would name the following:

Animals and Plants under Domestication. 2 vols. CHAS. DARWIN. \$6. (This not suggested for its doctrine, but as a useful work of reference.)

Hussey's National Cottage Architecture. \$6.

Landscape Gardening. DOWNING. \$6.50.

The Vegetables of America. F. BURR. \$5.

The Book of Evergreens. J. HOOPES. \$3.

Front Culture. DR. SLACK. \$1.50.

Farm Gardening & Seed Growing. BRILL. \$1.

The Dog. DINKS, MAYHEW & HUTCHINSON. \$3.

Young Sportsman's Manual. FORRESTER. \$3.

Hunter and Trapper. H. THRASHER. \$1.

The Market Assistant. DEVOE. \$2.50.

Hedges and Evergreens. WARDER. \$1.50.

Pear Culture. P. T. QUINN. \$1.

Money in the Garden. QUINN. \$1.50.

How Plants Grow. GRAY. \$1.25.

How Plants Behave. GRAY. 75 cts.

Illustrated Horse Doctor. MAYHEW. \$3.

Peach Culture. FULTON. \$1.50.

Barns, Out-Buildings & Fences. HARNEY. \$6.

Cottages and Farm Houses. WOODWARD. \$1.50.

Country Homes. WOODWARD. \$1.50.

ORANGE JUDD COMPANY,
245 BROADWAY, NEW YORK.

JUNE, 1874.

AMERICAN

AGRICULTURIST

FOR THE FARM, GARDEN & HOUSEHOLD.

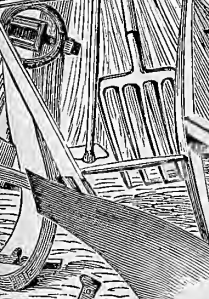
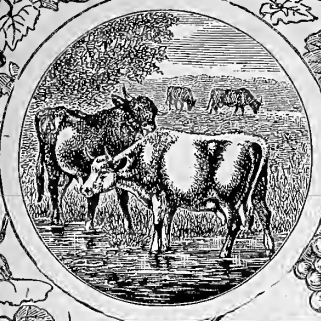

Vol. XXXIII

Number 6.

PUBLISHED BY THE
ORANGE JUDD COMPANY,
245 BROADWAY,
NEW YORK.



Standard Architectural Books for Carpenters and Builders.



Hussey's National Cottage Architecture; or, Homes for Every One.—With Designs, Plans, Details, Specifications, and Cost; with Working Scale. Drawings complete, so that Houses may be built direct from the book. Adapted to the popular demand for practical, handsome, and economical homes. Royal Quarto. Six Dollars, post-paid.

Atwood's Country and Suburban Houses.—Illustrated with about 150 engravings. Hints and Suggestions as to the General Principles of House-building, Style, Cost, Location, etc. Post-paid, \$1.50.

Monckton's National Stair-Builders.—Is a complete work on Stair-Building and Hand-Railing. Fully explained and illustrated by large scale diagrams, in two colors, with designs for Staircases, Newels, Balusters, and Hand-Rails. Royal Quarto. Post-paid, \$6.00.

Monckton's National Carpenter and Joiner.—A complete work, covering the whole science of Carpentry, Joinery, Roofing, Framing, etc., fully explained and illustrated by large scale diagrams in two colors. Royal Quarto. Postpaid, \$6.00.



Woodward's National Architect.—1,000 Designs, Plans, and Details for Country, Suburban, and Village Houses; with Perspective Views, Front and Side Elevations, Sections, Full Detail Drawings, Specifications, and Estimates. Also, Detail Drawings to Working Scale, of Brackets, Cornices, French Roofs, Sectional and Framing Plans of French Roofs, Dormer-Windows for French Roofs, Bay-Windows, Verandas, Porches, Plaster Finish, Cornices, Ceilings, Hard-wood Mantels, and all that is required by a Builder to design, specify, erect, and finish in the most approved style. One superb quarto volume. Post-paid, \$12.00

ORANGE JUDD COMPANY, Publishers, 245 Broadway, New York.

Woodward's Cottages and Farm Houses.—188 Designs and Plans of low priced Cottages, Farm Houses, and Out-Buildings. Post-paid, \$1.50.

Woodward's Suburban and Country Houses.—70 Designs and Plans, and numerous examples of the French Roof. Post-paid, \$1.50.



Woodward's Country Homes.—150 Designs and Plans, with Description of the Manner of Constructing Balloou Frames. Post-paid, \$1.50.

Woodward's Graperies and Horticultural Buildings.—Designs and Plans of Hot-Beds, Cold-Pits, Propagating Houses, Forcing Houses, Hot and Cold Graperies, Green Houses, Conservatories, Orchard Houses, etc., with the various modes of Ventilating and Heating. Post-paid, \$1.50.

Wheeler's Rural Homes.—Houses suited to Country Life. Post-paid, \$2.00.

Wheeler's Homes for the People.—100 Original Designs, with full Descriptions, and Constructive and Miscellaneous Details. Post-paid, \$3.00.

Harney's Barns, Out-Buildings, and Fences.—Containing Designs and Plans of Stables, Farm Barns, Out-Buildings, Gates, Gateways, Fences, Stable Fittings and Furniture, with nearly 200 Illustrations. Royal quarto. Post-paid, \$6.00.

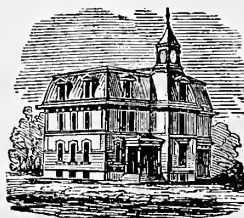

Eveleth's School-house Architecture.—A new and original work, containing Seventeen Designs for School-houses, Sixty-seven Plates with Perspectives, Elevations, Plans, Sections, Details, Specifications all drawn to working scale, with methods of Heating and Ventilation. Large quarto. Post-paid, \$6.00.

Copley's Plain and Ornamental Alphabets.—Giving examples in all styles, together with Maps, Titles, Borders, Meridians, Ciphers, Monograms, Flourishes, etc., adapted for the practical use of Surveyors, Civil Engineers, Draughtsmen, Architects, Sign Painters, Schools, etc. Post-paid, \$3.00.

Play and Profit IN MY GARDEN.

By E. P. ROE,

Author of "Barriers Burned Away," etc.

NOTICES BY THE PRESS.

The author takes us to his garden on the rocky hill-side in the vicinity of West Point and shows us how out of it, after four years' experience, he evoked a profit of \$1,000, and did so while carrying on pastoral and literary labors. . . . It is very rare that so much literary taste and skill are matched to so much agricultural experience and practical good sense. —*Harper's Magazine*.

This book is as poetical as it is practical. Still he is no dreamer. He goes into every essential detail with as much minuteness and precision as if he were writing a manual for the practical farmer. Indeed few works professedly devoted to agriculture give more sound and valuable information on the secret of winning golden harvests from the soil than this brief idyllic sketch. —*N. Y. Tribune*.

A very charming book, not only by reason of its pleasant style, but for its quiet refined humor and fund of really useful information on the subject of gardening. —*Boston Gazette*.

It deserves to stand side by side with "My Summer in a Garden." —*Christian Register*.

A fresh, lively work. —*N. Y. Observer*.

One reads without weariness and learns much of practical value. —*Chicago Evening Journal*.

Full of information. Explains just what the reader wishes to know. We most heartily commend it. —*Providence Evening Press*.

A chatty, sensible, profitable book. —*Cleveland Herald*.

The book gives much valuable information, and gives it in the pleasantest manner imaginable. —*Detroit Daily Union*.

Price, Post-paid - - - - \$1.50

ORANGE JUDD COMPANY,

245 BROADWAY, NEW YORK.

ENGLISH CHANNEL PRETTY WOMEN always like a neat foot, and buy nothing but ENGLISH CHANNEL Shoes. Ask your dealer for them. A dark line around the sole near the edge shows where the channel is cut. They never wear ragged.

Sexual Physiology.

By R. T. TRALL, M. D. Containing Sexual Generation; the Physiology of Menstruation; Impregnation; Pregnancy; Parturition; Lactation; the Law of Sex; Regulating the Number of Offspring; The Law of Sexual Intercourse; Hereditary Transmission; Philosophy of Marriage. Prof. Wilder, of Cornell University, says it is the best work yet written on the subject. 20,000 sold. Price \$2.00 by mail. For \$3.50 we send this book, The Herald of Health for one year, and a volume of the Complete Works of Shakspeare, containing 1,000 pages and 36 Illustrations. Agents wanted. WOOD & HOLBROOK, 15 Lighthouse St., New York.

\$25 A DAY GUARANTEED using our **WELL AUGER & DRILL** in good territory. Endorsed by Governors of IOWA, ARKANSAS & DAKOTA. Catalogue free. W. GILES, St. Louis, Mo.

FIRST Premiums awarded by Amer. Inst., 1870.

MICROSCOPES.

Illustrated Price-List sent free on application.

MAGIC LANTERNS.

Catalogue, priced and illustrated, sent free.

T. H. McALLISTER, Optician, 49 Nassau-st., N. Y.

INVENTORS Who wish to secure **PATENTS** should write to **MUNN & CO., 37 Park Row, New York, for Advice and Pamphlet, 103 pages, FREE.**

ADVERTISING RATES.

American Agriculturist.
ENGLISH EDITION.

Inside Pages, \$1.50 per line (agate), each insertion.

Open Pages (open without cutting), \$2 per line.

Last Page, and 2d and 3d Cover Pages—\$2.50 per line.

Page next to Reading and Last Cover Page—\$3.00 per line.

No advertisement inserted for less than \$5.00.

GERMAN EDITION.

Inside Pages, 25 cents per line, each insertion.

Business Notices and Last Page, 40 cents per line.

No advertisement inserted for less than \$1.00.

Hearth and Home.

Inside Pages, per line (agate), each insertion.....50 cents.

Business Notices, 7th Page, and Last Page.....75 cents.

Reading Notices per line.....\$1.00.

No Advertisement inserted for less than \$2.00.

No Advertisement of Medicines or Humbugs received.

Address all orders to the

ORANGE JUDD COMPANY.

245 BROADWAY, NEW YORK.

AMERICAN AGRICULTURIST

FOR THE

Farm, Garden, and Household.

"AGRICULTURE IS THE MOST HEALTHFUL, MOST USEFUL, AND MOST NOBLE EMPLOYMENT OF MAN."—WASHINGTON.

ORANGE JUDD COMPANY,
PUBLISHERS AND PROPRIETORS.
Office, 245 BROADWAY.

ESTABLISHED IN 1842.

Published also in German at \$1.50 a Year.

{ \$1.50 PER ANNUM, IN ADVANCE.
SINGLE NUMBER, 15 CENTS.
{ 4 Copies for \$5; 10 for \$12; 20 or more, \$1 each.

Entered according to Act of Congress, in May, 1874, by the ORANGE JUDD COMPANY, at the Office of the Librarian of Congress, at Washington.

VOLUME XXXIII.—No. 6.

NEW YORK, JUNE, 1874.

NEW SERIES—No. 329.



A PRIMITIVE MILL IN IRELAND.

One need not go to the Holy Land to find "two women" "grinding at a mill," as the ancient mill is still to be found among the Irish peasants. The mill consists of two stones about 22 inches in diameter, the lower being about an inch smaller than the upper. The upper face of the lower stone is convex, and has in its center a

strong pivot. The upper stone, which is concave on the lower side, to match the face of the lower stone, has a three-inch circular hole in its center; across this hole is fixed a strong piece of wood, which has upon its under side a hole extending part way through to serve as a socket for the pin in the lower stone. By

means of this cross-piece and the pin the two stones are kept together, and by placing bits of leather in the socket or hole in the cross-piece the two may be separated more or less as the meal is required to be coarser or finer. A handle is fixed on the upper stone. As in olden times, this mill requires two women to work it.

Contents for June, 1874.

Calendar for June.

A Primitive Mill..... Illustrated... 201
Bee Notes—Advice to Beginners..... 210
Boys and Girls' Column—Street Toy, The Magic Tape—He has a Strong Passion—Beautiful Charity—Games for Picnics—Old Fireplaces—Neat Puzzle—Aunt Sue's Puzzle-Box—Origin of an English Word—Goats—An Apology—Sanrise..... 4 Illustrations..... 227, 228
Butter, Fraudulent..... 217
Corn-Ears, Unloading..... 3 Illustrations..... 216
Corn-Marker..... Illustrated..... 219
Ducks, Raising..... 218
Ducks, Some Wild..... 4 Illustrations..... 213
Evergreens from Seed..... 222
Farm-House, a Convent..... 3 Illustrations..... 217
Farm Work for June..... 202
Feed, Consumption of..... 217
Fence, a Portable..... Illustrated..... 217
Flower Garden and Lawn in June..... 204
Fruit Garden in June..... 203
Fruit Prospects, Western..... 209
Greenhouse and Window Plants in June..... 204
Guano and Woolen Waste..... 218
Harrow, a New..... Illustrated..... 217
Hens, How to Manage Sitting..... 219
Hook for Sideboards..... Illustrated..... 218
Household Department for June—Farm Bath-Houses—Home Topics—Wet Boots—Wants to Suit George—Washing Milk Dishes—Tea-Cakes—Baked Apple-Dumplings..... 4 Illustrations..... 225, 226
Kitchen Garden in June..... 203
Mackerel and How they are Caught..... Illustrated..... 220
Market Gardener and Florist—Can one be Both?..... 223
Market Reports..... 204
My Garden Mistakes in 1873..... 223
Ogden Farm Papers, No. 52—Am. Jersey Cattle Club and its Prizes—Jersey and Alderney—Edward Burnett's Farm—E. F. Bowditch's Farm—Preventing Cows from Kicking—Green Clover for Soiling..... 210, 212
Orchard and Nursery in June..... 203
Plants—Improved Mignonette..... 222
Plants—Succulents as Decorative..... 3 Illustrations..... 221
Plants—Primula Japonica..... Illustrated..... 224
Plows, Swivel..... Illustrated..... 212
Poultry Farming..... Illustrated..... 216
Root Pulpers..... Illustrated..... 218
Skunks, How to Kill..... 219
Steam on the Farm..... 2 Illustrations..... 212
Stocks for Peach-Trees..... 222
Three Crops in One Year..... 224
Tiles, Making Drain..... 2 Illustrations..... 215
Timber Culture Act..... 219
Trap for Cut-Worms..... Illustrated..... 223
Walks and Talks on the Farm, No. 126—Early Lambs—Calves—Manure—Sheep—Pigs..... 214, 215
West, When and How to Go..... 215
Wheat Culture, Future Prospects of..... 219

Calendar for June. Table with columns for Day of Month, Day of Week, and sunrise/sunset times for Boston, N. York, Philadelphia, and Washington.

PHASES OF THE MOON. Table with columns for MOON, BOSTON, N. YORK, WASH'N., CHA'STON, CHICAGO.

AMERICAN AGRICULTURIST.

NEW YORK, JUNE, 1874.

Every spring furnishes renewed evidence of the advantage of underdraining, and also, on many soils, of fall plowing. On our own farm we were able to sow oats and peas April 21st on sod plowed this spring. Barley we sowed April 25th. This is late sowing, but it is the best we could do, and if the land had not been underdrained it could not have been plowed and sowed for a week or ten days later. This often makes the difference between a good and a poor crop. We have had an unusually cold and backward spring. Winter wheat was much injured by freezing weather and cold winds in March and April. On wet land it has been badly winter-killed—or, more correctly, spring-killed. On many farms in our own vicinity not a furrow was plowed until the first of May. Farmers who can raise good crops this year will probably have no reason to regret the time and money they have spent in draining, cleaning, and enriching their farms or in improving their stock.

We hope and believe that we shall see no more 25-cent corn for some years. We shall hear little about "over production." The railroad magnates will learn that farmers will not long continue to raise crops and sell them at a loss. And farmers will learn that it is better to sell their hay and grain in the form of beef, pork, mutton, cheese, butter, and wool than to transport it long distances to market in the raw state. Clean land, larger crops per acre, better breeds of stock, and more liberal feeding are the fundamental planks in the American Agriculturist's platform. Here we have stood for years and here we now stand. We wish every farmer in the United States to join our party.

Hints about Work.

The Season is Late, and much land intended for spring grains has not been sown. Corn may still be Planted.—The small, early, northern varieties are the best for late planting. Put in all the Crops you can take good care of. They are likely to be wanted. Corn Planted by Hand may be soaked in warm, soft water for twenty-four to thirty-six hours. If

the land is moist, mellow, and warm, it will soon germinate and grow rapidly.

Pour the Soaked Corn and water on to a sieve, and after the water has drained off spread it out to dry for an hour or two, and then dust it over with plaster and stir it with the hand until every kernel is coated with plaster. This will not only make it easier to separate in dropping, but it will help the growth of the young plants. We have dropped soaked corn with a drill, but it is, of course, necessary to calculate for the increased size of the corn, and also to see that there is no clogging or crushing of the grain.

Corn for Fodder may be sown any time this month. You must have rich, dry, clean, and mellow land. If it can be avoided, never sow broadcast. Drill or drop in rows 2 1/2 to 3 feet apart, so that you can use a horse hoe to clean and mellow the land. Use plenty of seed, say from six to eight kernels to each foot in the row.

Beans are usually drilled or dropped in rows 2 1/2 feet apart. If dropped in hills a foot apart in the rows, put from four to six beans in each hill. This plan facilitates hoeing and pulling. If drilled in a continuous row use a little more seed, say eight or ten beans in a foot. Go over the field after the drill and see that all the beans are covered.

The Depth of Planting depends very much on the kind of soil and on its condition. On light soil seed may be put in deeper than on heavy soil. At this season it is necessary to plant deep enough to reach the moist earth, say from one to three inches deep.

Harrowing is rarely done as thoroughly as it should be. It is very important to make a fine, mellow seed-bed.

Rolling is also too much neglected. Roll and then harrow and then roll again until you have four or five inches of fine surface soil. Such a soil will attract and retain moisture.

Suedes Turnips or Ruta-bagas should be sown about the middle of the month or before. The soil should be made as fine and mellow as possible. Drill in rows 2 1/2 feet apart, using two to three pounds of seed per acre. The object of such thick seeding is to give some of the plants a chance to get ahead of the so-called turnip-fly or beetle. If possible, drill in with the seed two or three hundred pounds of superphosphate per acre, mixed with three or four times its bulk of sifted coal ashes. Thin out the plants when in the rough leaf to a foot apart in the rows. Do not neglect to roll the land immediately after sowing.

Mangel-Wurzel or Beets should now be ready to hoe. Thin out to fifteen inches apart. If it is necessary to transplant, be careful to dig up the plants with the hoe, and not pull them up out of the hard earth and thus strip off the soil and fine roots. In hoeing, do not cut too deep. In hoeing turnips, it will not hurt the plants to take away nearly all the soil from their roots; but this is not the case with mangels. The less the soil around the roots of the young plants is disturbed the better. Cultivate every week or ten days. You should have a narrow tooth horse hoe, so as not to throw the earth on to the young plants.

Fight the Weeds.—Fight them as you would fight a fire. Do not let them get beyond your control. Kill them while in the seed-leaf. On loose, mellow soil, a fine harrow, if used just as the weeds are breaking through the soil, will kill them by the million; but if delayed a few days in warm, growing weather it will have comparatively little effect.

Start the Cultivator the moment you can see the rows of corn, or potatoes, or mangels. The outside teeth of the cultivator should be bright, sharp, and as thin as possible consistent with the necessary strength, and they should be set so as to throw the earth towards the center of the row. With a good cultivator the soil may be stirred within an inch of the plants, and leave little necessity for hand hoeing.

Summer Fallows must not be neglected. In breaking up sod land use three horses abreast, and turn over a good furrow. Then roll, and afterwards

harrow thoroughly lengthwise of the furrows. In a week or so put on a two or three horse cultivator, and in a few days follow with a harrow and then cultivate again as soon as any weeds appear. Whether it is best to plow only once, or two or three times, is a disputed point. Whichever plan you adopt, let the work be done thoroughly. That plan is best, other things being equal, which causes the most weed seeds to germinate and then kills the plants.

Rainy Days can be turned to good account in getting ready for haying, in cleaning and white-washing cellars, in repairing broken tools and implements, and putting everything in order.

Hang Things up.—Do not throw plow-points, cultivator-teeth, wheels, coulters, harrow-teeth, chains and pieces of chain, rings, clevis, extra whippletrees, neck-yokes, etc., into some dark and dusty corner, but put some wire round them and hang them up where they can be seen.

Grind Hoes, and keep them constantly bright and sharp. Spades also, and if you have a power grindstone it will pay well to grind coulters, cultivator-teeth, and plow-points.

Clover should be cut for hay as soon as the earliest blossoms begin to get brown. There can be no doubt that early cut hay is more nutritious, or at any rate more readily digested, than when the grass or clover is allowed to get ripe.

Timothy and other grass, if intended for consumption on the farm, should also be cut early. If to be sold for city horses, you will get more hay, and a better price, by letting it grow until the seed is beginning to form.

In Curing Clover Hay, our own plan is to start the machines in the afternoon and keep cutting until dark. Dew or rain will not hurt grass while it is green. The next morning, after the dew is off, rake the partially dried grass into small windrows with a steel rake. Turn them immediately after dinner, and towards night rake into larger windrows and put into cock. Turn or spread out the cocks the next morning, and draw in the hay in the afternoon.

Milk Cows should now furnish a full pail of rich milk. See that they have access to plenty of fresh water. Unless the grass is unusually rich, from one to two pints of corn-meal stirred in a pail of water and given twice a day will often prove profitable.

Calves and young stock should have the best of pasture and more or less corn-meal soaked in water or cooked. The quantity will depend on the age and other circumstances. As a rule, from half a pound of meal to one pound for each 100 lbs. of live weight will not be over-feeding.

Sheep.—The above rule will apply to sheep. The English farmers find it profitable to give grain or oilcake to their fattening sheep and lambs even when running in rich pastures.

Ewes and Lambs should have good pasture and access to water. The lambs will pay well for a little grain fed in an inclosure separate from the ewes. For scours, change the pasture and let the sheep have what hay they will eat.

In Washing Sheep, be careful to keep the nose and mouth of the sheep out of the water. Tag the sheep before washing.

Lambs should be dipped in a solution of carbolic soap to kill ticks. Repeat in two or three weeks.

Swine should have access to fresh water and the run of a good clover or grass pasture. Let them have coal or wood ashes, salt, sulphur, and charcoal—all they will eat.

Young Pigs are unusually scarce, and pork is likely to bring good prices. Feed liberally. Give the young pigs all the milk. The old ones can get along without it. The secret of producing good and cheap pork is to get an improved breed and feed liberally, especially while the pigs are young.

Nothing will Pay Better than to cross common sows with a thorough-bred boar of a well-established and highly improved breed, such as the Essex, Suffolk, or Berkshire. Now is the best time

to order a young, two months' old boar. He will be ready for moderate use next fall and winter.

Work in the Horticultural Departments.

June will bring its abundance of fruits and flowers; strawberries, raspberries, currants, and other small fruits will follow each other in quick succession; the early vegetables should also yield an abundant supply. Weeds will grow rapidly in the now warm soil, and should be destroyed as soon as they appear. Some crops may have failed owing to too early sowing or too wet weather; all such should be replanted at once before it is too late. In a favorable season seeds will germinate very rapidly, and it is not too late to sow and expect a fair crop of most things. Succession crops ought to be sown all the season; corn if sown every two weeks, even until July, will generally pay, for if it fails to produce a crop of ears the fodder is the best possible food for cows.

Orchard and Nursery.

Trees set out this spring will need attention, to see that they acquire proper shape. Where buds appear which are not needed for branches rub them off. Do not allow the trees to be displaced by the wind; to prevent this, two or three large stones placed around the roots are better than stakes for keeping them in place. See that the trees have open heads; low heads are better than high ones.

Grafts set last month will require attention. Remove shoots which start on the stock, so that all the nourishment may be given to the graft. If two cions have been put on the same branch, remove the smaller if there is danger from crowding.

Budded Stocks.—Sometimes the shoot from the bud is so vigorous that the newly formed wood is not strong enough to withstand the winds; when this is the case they should be staked.

Pruning.—June, by most orchardists, is considered the best month in which to prune, especially where large limbs are to be removed. Cover the wounds with liquid grafting-wax, paint, or other protection to prevent decay.

Orchards containing young trees should be cultivated in such a manner as to keep the soil mellow; this may be done by planting crops between the rows, to which plenty of manure is given.

Thinning can hardly be too severely practiced upon young trees, and older ones are greatly benefited if half or more of the fruit is removed. The quality of the remaining fruit will be enough improved to repay the trouble. Thinning will give a crop of fruit every year.

Seed-Beds of evergreen and deciduous trees will need shading with screens of lattice-work or evergreen boughs. The shading must be so arranged that air can circulate freely around the plants.

Insects.—He who would have good fruit as well as healthy trees must keep a sharp lookout for every species of injurious insect. Caterpillars of all kinds will have to be looked after sharply. Another very destructive insect is the

Borer.—The parent deposits the eggs near the base of the tree, where they are hatched, and the young borers work themselves into the tree. To prevent this, wrap a piece of thick paper around the tree, the lower edge of which should be below the surface of the soil.

Slugs appear on the leaves of the pear and cherry, and are small, green, and slimy. Lime or ashes dusted over will destroy them.

Fruit Garden.

Strawberries.—If not mulched before this, attend to it at once. Any material which will keep the fruit from being soiled will do. If the crop is to be marketed, provide plenty of baskets and crates for shipping.

Blackberries.—Do not allow the new canes to

grow over five feet; when they reach this height pinch off the end. This will induce the growth of side branches; these ought to be stopped when they reach a length of eighteen inches.

Raspberries.—Four new canes to a stool are enough, unless more are wanted for planting. A good plan for training is to tie the canes to a wire stretched along the row, and attached at each end to a firmly-set post.

Currants.—Apply a heavy mulch of litter to keep the weeds down as well as to keep the ground moist. Give the bushes a dusting with powdered white hellebore if attacked by borers.

Grape-Vines.—If vigorous, healthy vines are wanted, do not allow but one shoot to grow the first season after planting. Rub off all other shoots, and keep this one tied to a stake during the season. Young vines should not be allowed to overbear; two bunches to a shoot are enough. For training older vines there have been recommended a great many plans. Any may be adopted which keep up a supply of bearing wood down near the ground.

Insects will be troublesome here as well as in the orchard, and should be carefully looked after, and the larger beetles and caterpillars removed by hand-picking.

Kitchen Garden.

Work will be lively here from the constant hoeing and cultivating required to keep the weeds under subjection.

Hoe and Rake.—These are both necessary implements in the garden, and should be kept sharp. The wheel-hoe described in a former number of the *Agriculturist* is a great improvement over the old form; with this a man will do twice as much work and do it better than with a common hoe. The bayonet hoe or its improvement, the lance-head hoe, are very useful in weeding and thinning out the rows of carrots, parsnips, etc.

Seeds of many things can be sown now and with the prospect of a good crop. Beets sown now will make a rapid growth, and even until the first of July the prospect of a crop is good.

Asparagus.—Do not cut after the peas are plenty. Hoe over the bed occasionally to keep down the weeds, and if there is well-rotted manure to be had apply now.

Beans.—Continue to plant the bush sorts for late snaps.

Beets.—Keep the early sorts well hoed, and thin as soon as large enough to handle. The thinnings make good "greens." Sow early sorts now for succession.

Cabbage.—Transplant the early and medium sorts from the seed beds and sow for late. The cold-frame and very early hot-bed plants will now be fit for the table or for market. When the early crop is harvested the land should be plowed and manured for other crops.

Carrots.—It is not yet too late to sow, but it should be done at once. Keep the young plants free from weeds.

Celery.—Young plants in the seed-bed should not be crowded or allowed to become weedy.

Corn.—Sow every two weeks for a succession; later in the season sow only the early sorts, as the others will not have time to grow.

Cucumbers.—Prepare well-manured hills four feet apart each way, and use plenty of seed, and manure in the hill. There are many devices for keeping off the "striped bug," but some simple covering answers.

Egg-Plants require a rich soil, and should not be planted until the ground is warm and dry. The "green-worm" which attacks the tomato also preys upon the egg-plant; the only remedy is hand-picking.

Endive.—Transplant and sow seeds for late crop. *Lettuce* seldom does well in summer unless planted in a shady, moist place.

Melons need the same care as cucumbers, except

that they should be planted from four to eight feet apart according to the variety.

Onions require careful attention to prevent the growth of weeds. If there is a near market they are usually more profitable when green and half grown than if allowed to ripen.

Pursnips need to be hoed often, or until the leaves cover the ground.

Peas.—Plant for a succession, taking care to cover deeply. Give brush to all that need it.

Rhubarb.—The flower-stalks should be removed as soon as they appear. When fruit comes stop cutting and give the plants rest.

Ruta-Bagas may be sown the last of this month. Dust on ashes or plaster as soon as up to keep off insects.

Salsify.—Keep the plants hoed and the ground loose and mellow. Seed may be sown at once, but the roots will not be so large as if planted earlier.

Spinach goes to seed so quickly during summer that it is of but little use to sow now. New Zealand is best suited for hot weather.

Squashes.—Plant the same as cucumbers; the bush sorts three to four feet apart, and the large-growing winter sorts eight feet.

Sweet-Potatoes.—The first week in June is early enough to plant at the North. Set out the plants, 12 or 15 inches apart, on well-manured ridges.

Tomatoes.—Set out plants and keep well hoed. Provide some support in the shape of brush or trellis; this will allow the fruit to ripen, and also prevent it from becoming soiled by the earth.

Flower Garden and Lawn.

Lawns.—In order to obtain a velvety surface, the lawn should be cut frequently. For this purpose a lawn-mower is needed, as it leaves the lawn with a smooth surface, and not ridged as when mowed with a scythe.

Annuals may be sown in the open ground now that it is well warmed. Transplant such as require it, and weed those already sown.

Bedding Plants should be planted out in the borders where the practice of massing is followed.

Specimen Plants from the greenhouse are often used to ornament the grounds with good effect. Oranges, Oleanders, Palms, and any other subtropical plants are useful for this purpose.

Fuchsias.—Do not plant in the open ground unless there is some shady spot for them.

Bulbs.—Hyacinths, and other fall bulbs should be taken up as soon as the leaves begin to decay. Tuberoses started under glass may be set in a warm spot. Plant out Cannas, Gladioluses, and Caladiums in beds on the lawn or in the borders.

Climbers, whether woody or herbaceous, should be provided with stakes or trellises.

Weeds will grow rapidly here as well as in the vegetable garden, and care must be taken to keep them down.

Greenhouse and Window Plants.

Do not remove all the plants from the greenhouse during the summer; enough should be left to make good show during the season. Make all necessary repairs now before the house is needed for the plants in the fall. Shade will be needed, and should be given either by whitewashing the glass on the outside or by means of screens.

Commercial Matters—Market Prices.

The following condensed, comprehensive tables, carefully prepared specially for the American Agriculturist, from our daily record during the year, show at a glance the transactions for the month ending May 13th, 1874, and for the corresponding month last year:

Table with columns: RECEIPTS, Flour, Wheat, Corn, Rye, Barley, Oats, and SALES, Flour, Wheat, Corn, Rye, Barley, Oats. Rows show data for 25 days ending May 13th, 1874, and 24 days ending May 13th, 1873.

Table 2: Comparison with same period at this time last year. Columns: RECEIPTS, Flour, Wheat, Corn, Rye, Barley, Oats. Rows show data for 25 days ending May 13th, 1874, and 25 days ending May 13th, 1873.

Table 3: Stock of grain in store at New York. Columns: Wheat, Corn, Rye, Barley, Oats, Mill. Rows show data for May 11, 1874, and previous dates from April 6 to Dec 10, 1873.

Table 4: Exports from New York, Jan. 1 to May 9. Columns: Flour, Wheat, Corn, Rye, Barley, Oats. Rows show data for 1874 and 1873.

CURRENT WHOLESALE PRICES.

Large table of current wholesale prices for various commodities including Flour, Wheat, Corn, Rye, Barley, Oats, Beans, Peas, and various oils and fats. Columns include item names and prices for different grades and quantities.

Gold has been up to 114 1/2 and down to 111 1/2—closing May 12th at 112 1/2 as against 113 1/2 on April 11th. With the resumption of inland navigation comes the promise of renewed activity in the wholesale produce line. The earliest receipts from the Canal have come to hand within a few days, and have made liberal and much needed additions to the available supplies, especially Breadstuffs. The demand has been fairly active, in good part for export. The distribution of stock has seriously diminished the amount remaining in store at this point. The high range of ocean freights has been against the export business. Prices of Flour and Grain closed lower. Cotton has been more active, for both prompt and forward delivery, at advanced figures. Provisions have been quite freely dealt in, particularly Pork and Lard, which closed higher, on a lively speculative inquiry. Tobacco, Hay, and the better grades of Hops have been selling moderately within our range. A more active business has been noted in Wool. Manufacturers have been making more liberal purchases,

chiefly to provide for immediate wants, while the trade inquiry has been moderate. Prices have shown firmness on really desirable grades of stock, which have been offered sparingly. Little new clip, comparatively, has as yet reached this market, but considerable receipts of California by rail are looked for soon. Included in the recent sales in the local market were: Domestic Fleeced at from 48c. @ 55c.; Georgia at 25c.; Unwashed stock at 30c. @ 40c.; Washed at 35c.; Scoured at 55c. @ 58c., chiefly at 55c. @ 70c.; Combing at 50c. @ 65c.; Domestic Puled at 25c. @ 50c.; Lambs at 26c. @ 30c.; Texas at 18c. @ 32c.; California Fall at 18c. @ 26c.; 17,000 lbs. New California Spring Clip, at 23c. @ 32c.; and 17,000 lbs. Noils, part domestic, at 47c. @ 50c. At Boston considerable sales have been reported of new clip California Spring at 31 1/2 @ 36c., the latter rate for fancy lots. In most other commodities trade has been comparatively tame.

New York Live-Stock Markets.

Table of receipts for various live stock including Beef Cattle, Sheep, Swine, and Horses. Columns: WEEK ENDING, Receipts, and various stock types.

Beef Cattle.—The month's business closes unfavorably for sellers, after a brisk trade, at gradually rising prices during the previous three weeks. Freighters are now less than 40c. a hundred from Chicago to New York, and consumers look for a share of the advantage. If freight were just nothing, it is a question if farmers or graziers would reap a cent's worth of advantage, and if the consumers whose needs really make the markets would not get the profit. As it is, prices in the West are just now too high for dealers to make money at current rates here, and as we close our report they are losing \$2 to \$5 a head on every beast sold. The market is down at least 1/2 c. @ 1/2 c. per lb. since May 4th, and this does not show all the loss, as the estimates are also against the seller, and a good many head, at least 25 carloads, go over unsold. Poor native steers to dress 55 lbs. to the gross cwt. sold at the close at 9 1/2 c. per lb., and the best at 12 1/2 c. to dress 55 lbs. Fair Texans at 10c. @ 11c., and fat bulls at 5 1/2 @ 5 1/2 c. per lb.

The prices for the past four weeks were as follows: WEEK ENDING, Range, Large Sales, Average. April 20, 9 @ 13 c., 10 1/2 @ 11 1/2 c., 10 1/2 c. April 27, 8 1/2 @ 13 c., 10 1/2 @ 11 c., 10 1/2 c. May 4, 9 1/2 @ 13 c., 11 @ 11 1/2 c., 11 1/2 c. May 11, 9 1/2 @ 12 1/2 c., 10 1/2 @ 11 1/2 c., 11 c.

Milk Cows.—In this class of stock there has been a steady business at fair prices. All that have been offered were taken readily, and dealers report a fair demand, at \$40 to \$80 per head for cow and calf. Really choice family cows have sold at \$90 to \$100 per head.

Calves.—The unwholesome practice of shipping "bobs" at the tender age of ten days only demoralizes the market for veals. Hundreds of these "bobs" are allowed to come on the market under the noses of the inspectors, and prices are run down in consequence. The market is weak under the pressure, and 4c. @ 7c. is all that is quoted for poor to prime veals.

Sheep and Lambs.—Clipped sheep are now coming in, and have met with an active demand until the last week, when an increased supply and a weak market meeting prices went down and some sheep went over unsold. For prime shorn sheep 7 1/2 c. @ 8 1/2 c. is quoted at the close, and for unshorn 8c. @ 9 1/2 c. Good lambs are selling as we write for 11 1/2 c. @ 12 1/2 c. per lb. Swine.—Live hogs have been without animation throughout the month, and close dull at 5 1/2 c. @ 5 3/4 c. per lb. Dressed hogs have been active, but close easier at 7 1/2 c. per lb.

Preparing Poultry for Market.

A gentleman in Maine reports that he followed the directions for preparing poultry given in the Agriculturist for November last, and that in the Portland and other neighboring markets his poultry brought him several cents a pound less than it should have done had he not scalded it. At the head of the directions it was stated that they were for the New York market, and we did not expect them to apply to any other. In the matter of poultry especially, the customs in the markets of cities vary greatly, and to bring the best prices the poultry must be dressed according to the customs and prejudices prevailing at the place where it is to be sold. For example: poultry that is not drawn will not meet with a ready sale in Boston, Providence, or other New England cities, while drawn poultry in New York is likely to spoil on the hands of the dealers. Each one should make himself acquainted with the requirements of the market to which he proposes to send produce of any kind.

The ORANGE JUDD COMPANY,

PUBLISHERS,

245 Broadway, New York.

Officers { ORANGE JUDD, President,
and Chief { C. C. NORTH, Vice-President,
Proprietors: { SAMUEL BURNHAM, Secretary.

* Messrs. L. A. CHASE and A. P. MILLER, being engaged in other business pursuits, have retired from official connection with the ORANGE JUDD COMPANY.

LAST CALL ON THE GENERAL LIST OF PREMIUMS For 1874. ONE MONTH MORE.

One Month—June—yet remains, during which any person who wishes to obtain one or more of the useful and valuable articles offered in our Premium List (of which a copy will be sent free to any applicant, see page 239) can easily get them. This has already been done by more than 14,000 persons, who during years past have tried with success the raising of Clubs of Subscribers for our papers, and availed themselves of the liberal offers of Premiums made by the Publishers.

We invite all our Subscribers to take hold of this work and secure a Premium while the offer is open. Specimen copies of our papers will be sent to any wishing to show them for this purpose.



containing a great variety of Items, including many good Hints and Suggestions which we throw into smaller type and condensed form, for want of space elsewhere.

Remitting Money:—Checks on New York City Banks or Bankers are best for large sums; make payable to the order of Orange Judd Company. Post-Office Money Orders for \$50 or less, are cheap and safe also. When these are not obtainable, register letters, affixing stamps for postage and registry; put in the money and seal the letter in the presence of the postmaster, and take his receipt for it. Money sent in the above three methods is safe against loss.

Postage: On *American Agriculturist*, 12 cents a year, and on *Hearth and Home*, 20 cents a year, in advance. Double rates if not paid in advance at the office where the papers are received. For subscribers in British America, the postage, as above, must be sent to this office, with the subscription, for prepayment here. Also 20 cents for delivery of *Hearth and Home* and 12 cents for delivery of *American Agriculturist* in New York City.

Bound Copies of Volume Thirty-two are now ready. Price, \$2, at our office; or \$2.50 each, if sent by mail. Any of the last seventeen volumes (16 to 32) will also be forwarded at same price. Sets of numbers sent to our office will be neatly bound in our regular style, at 75 cents per vol. (50 cents extra, if returned by mail.) Missing numbers supplied at 12 cents each.

Vick's Premiums.—Our friend Vick is one of the irrepresibles. This time he offers liberal premiums for the best exhibition made at any state fair this fall, of flowers raised from seeds purchased from him. Those interested can obtain circular of particulars by addressing James Vick, Rochester, N. Y.

Mr. Orange Judd, whom the papers all over the country have had as likely not to live to get home, or as the last account had it, was dying at Geneva, quietly walked into the office on April 25th, looking very much unlike one in the condition these papers had repre-

sented him. Mr. Judd had not been in a satisfactory state of health since the severe illness which overtook him while on the United States Sanitary Commission in 1864, and last summer he quietly slipped off to European search of complete rest. His many friends will be glad to learn that he returns looking as if he had taken a new lease of health and had no present idea of going on the retired list.—Ed.

The Centennial Gazetteer of the United States.—A gazetteer for this country only is a thing that has long been wanted, and in one by Gen. A. von Steinwehr, and just published by Ziegler & Mc Curdy, Philadelphia, we have a compact and comprehensive one. A work of this kind can only be properly judged after an extended acquaintance, and we base our good opinion of this from a long acquaintance with the author, whom we have known in the field as a most excellent topographer, and out of it as an enthusiastic geographer. During the few weeks that we have had the volume it has been in frequent use, and in no case has it failed us for even the most obscure places. It is based upon the last census, the post-office department records, and all the official sources of statistical information. Each state and territory has a very exact description of its physical features drawn from the most recent surveys, and the work can not fail of being of great assistance to those who are looking westward. The statistics of counties are also very useful. We congratulate the author on having made a valuable addition to our handy books of reference.

The Cable Screw Wire Shoes.—"J. W.," Lancaster Co., Pa. Durability and comfort in wear the shoes and boots made with the cable screw wire will be found superior to those made with wooden pegs, as the wire is forced through the leather and riveted by machine in such a way that they can not shrink and work loose. No water can enter these shoes, and they will not come apart. For the rough work necessary upon the farm this is a great advantage. The address of the makers is the Cable Screw Wire Company, Boston.

No More Advice.—Mr. Fred. Mather, of Honeoye Falls, N. Y., whose communications on fish culture we have sometimes published, is quite tired of answering letters asking advice, and wishes us to say so to our readers. He says: "Circumstances vary so much—soil, flow, temperature, material, and objects of the owner—that justice to myself demands that I should not risk my reputation in giving advice by mail. As I am engaged to the U. S. Fish Commission for the next season, I can recommend parties to employ an expert, and thus avoid expensive mistakes."

The Japan Pea.—"Jap" writes: "When properly cooked, they are very palatable to persons who are fond of beans or peas, for the taste resembles a mixture of navy beans and lady peas cooked together. To cook them: Put in soak overnight in warm water; then boil them, taking care not to add cold water, grease, or salt. When done, mash, season to suit taste, and bake."

Sawdust as a Mulch.—"J. C. C.," Washington, Ind. If your sawdust is, as you say, "thoroughly rotted," it will be an excellent mulch around your trees. Fresh sawdust is objectionable around young trees, as it forms a bed for the growth of fungi, which are said upon good authority to injure the tree. If the sawdust is considerably decomposed, it might be a better use of it to compost it with lime and use it as a fertilizer rather than as a mulch.

A Remedy for Looseness.—"J. W. B.," Bay River, S. C. In a case of looseness of the bowels in a horse we would give half an ounce of prepared chalk and half an ounce of ground ginger in the feed once a day. As indigestion is probably the cause, the feed should be carefully selected, and what grain is given should be ground. An ounce of salt should also be given in the feed daily.

Cabbage Worms.—"W. N. B.," Pa. We can not recommend any "certain" remedy for the cabbage caterpillar, by that meaning the now troublesome larvae of *Pieris rapae*. The butterflies, white with black spots on their wings, appear with the first warm day, and in early morning are easily caught with a sweep-net. Every female killed will prevent the birth of many "worms." Any application to the caterpillars must be made while they are very young, as they soon hide themselves and are sheltered by the central leaves. Salt, guano, etc., must touch the caterpillar to be of any service. When the butterflies are seen about, the eggs and young caterpillars should be searched for. It is very fortunate that this pest disappears as suddenly as it comes; it probably has several natural enemies; at all events a lo-

cality will be devastated by them one year and quite free from them the next.

SUNDRY HUMBUGS have been like the season, "very backward in coming forward," yet still they are not by any means dead. When one is killed we never know that it is dead. A well-known American quadruped which is fond of prowling around poultry yards is easily shot, but that is by no means the last of him—he leaves a fragrant memory for weeks and weeks. It is so with these humbugs, even after the law has put its quietus upon them, their scented trail extends far and wide. The law effectively squelched a most barefaced project of a "Library Concert," which so misappropriated the pleasant name of Magnolia, yet its all-pervading scent comes to us in the form of letters from far-off places. The industry with which the managers of this swindle worked is something remarkable, and they seem to have aimed at the most distant territories. One gentleman in Dakotah writes that they were especially busy there. The latest of these gift concerts comes, of all places in the world, from Utah, and is the

FIRST GREAT SALT LAKE GIFT CONCERT,

which is to be drawn on the 4th of July next, all for the benefit of the "Public Free School, the only free school in Utah." Then such a flashy programme, and the big figures, \$26,500.00 to be distributed, has a look quite as large and lively as that Kentucky scheme. Now this town of Corinne had at the last census, 1870, just 783 population. Corinne, for a small town, you make a great blow. Asking the people to buy 500,000 of your tickets at \$1 each in order that you may have "the only Free School in Utah" is equal to anything in the way of bombast we have seen. . . . Chicago claims to be the metropolis of the West, and has of course her metropolitan luxuries; one of her chief ornaments just now is the firm of

HOWARD & CO.,

who profess to import and manufacture watches, jewelry, and silverware. Whether this is the same Howard & Co. who a few months ago flourished in Philadelphia on the \$4 Geneva watch dodge, we are not aware. But they must be mighty nice people to send a school-boy a bill of \$20.25 for repairing a hunting, stem-winding, gold chronometer, with the following letter:

"Dear Sir: The watch received from you January 15th is now ready for delivery. You were correct when you stated it could not be repaired outside of our house. We have had great difficulty with it, but it is now in thorough order, and we will warrant it to keep correct time for five years. You wrote that the watch was found, and desire to know its worth. It is a very valuable time-piece, and must have cost at least \$500 in gold. It is now worth \$400, in gold, and for any one desiring a reliable time-keeper is really cheap at first cost. Please remit amount of bill by express, and the watch will be immediately forwarded. Respectfully,

HOWARD & Co."

That is a very pretty trick, Messrs. Howard & Co., but, unfortunately it is an old one. The Minnesota boy, to whom you sent it, is one of the kind who reads the *Agriculturist*, and no doubt had a good laugh at your expense. But doesn't it look mean, though, when you see it in print. You will probably catch many boys and men who (think they) can not afford to take this journal, and in their simplicity will forward the "\$20.25," hoping to get somebody's \$400 watch. The \$20 would pay for the *Agriculturist* 20 years, or for 20 copies a whole year. The "Howard & Co." here referred to must not be confounded with the worthy and reputable house of Howard & Co., New York City.

THE \$5 SEWING MACHINE

offered last month on favorable terms still remains on hand. Now that Barnum has returned we may get rid of it, for we are quite sure that he saw not its equal in Europe. We advise all persons to be exceedingly cautious of any cheap sewing machines advertised from Greenwich or Canal streets. These places, though carried on under different and changeable names, are equally obscure, and from the numerous complaints we have of persons who have sent money and received no return are equally suspicious. We can not conceive how any person can be so inconsiderate as to send money to a person for whose honesty they have no assurance, for a machine not advertised through the regular channels. *Moral:* Let all doubtful sewing machines severely alone. One lately advertised from Greenwich st., and one Mulligan from Greenwich or Canal, just as it pleases. This Canal st. cirenar has a flaming heading of "Steam Iron Works" and all that; but upon going to look him up at his number, we found no exterior sign, and only found where his room was by inquiring in a hair-dresser's shop on the lower floor. Whatever else may be done by M., he does not waste money on signs.

VILE LITERATURE

seems to have taken a fresh start. We include under this head not only offers of books, that are actually ob-

scene, but those works which propose to teach impossibilities. If the American Book Co., Manchester, N. H., and the Central Book Co., Garrettsville, O., are not engaged in a business which should induce the authorities in those towns to shut them up as nuisances, then they should not send out the circulars they do. Strictly speaking, it is just as much a fraud to get money by inducing a person to think that the books offered are bad ones, as in any other way. The circulars of both these concerns are vile in the extreme. . . . In the same category we place the Central Book Co., Ashland, Mass., with its offer of a book to teach the making of "love powders" and all such nonsense. . . . And equally rascally is the circular of Willis & Co., of Williamsburgh, N. Y. What fools these Willis & Co. are. They propose to sell a book with all sorts of secrets—upon one of which "many men have retired with a large fortune." These chaps say, with equal disregard of grammar and truth: "My arrangements with the post-office are such as that if you address correctly it is impossible money to be lost." The very contents of their circular show that they are by law shut out from the use of the post-office altogether. . . . There is a so-called publishing concern in Springfield, Mass., about which an amount of unpleasant evidence is accumulating.

THE HOTEL DODGE

has at last turned up again. We had supposed that had gone off with old "sands of life," but here it is as bright and blooming as ever. Perhaps some of our newer readers do not know this stale old trick. This time it is "Respy" E. Callinwater, who keeps a hotel, which it is the Arcade, in New York, of course, and on the "European plan." An unfortunate citizen, A. E. Clements, stopped at said hotel, but in two days he up and died, probably on the "European plan." No wonder he died, for he must have eaten and drank fearfully, as his bill for two days at this Arcadian place amounted to \$11.75. Fortunately the defunct left a trunk, which Callinwater opened, and found "a fine gold watch, two silver-mounted revolvers, gold ring, clothing," etc. But more than these—he found a paper addressed to another Clements away down in Georgia. Happy thought for Callinwater! He writes to the Georgia Clements, telling him that the trunk is valuable, and he is the proper person to have it, which he can do by forwarding to Cal. the amount of \$11.75, due by the defunct Clem. The Georgia Clem. doesn't bite worth a cent, but writes us to sell the pistols and pay Cal., and send on the "rest of the estate." He desires to express his grief for the loss of his relative, but particularly wants that trunk. We should just like to know what Cal. did with the body of the deceased Clem. Did he dispose of that "on the European plan?" It appears that here is a case for the coroner to look after, as people who leave gold watches and such things around don't generally get buried for nothing in New York. It may be that the new cremation society has got hold of his body and incinerated it as an experiment, and the unfortunate is now only a small handful of ashes.

WHAT IS THE C. O. D. SUPPLY CO?

After the inglorious ending of the Union Furnishing Store at Chicago we should think that this "C. O. D." business would rest awhile, but it has started anew, and the circulars and plans are so like the old that it looks "much of a muchness." To the lady in S. C., and other inquirers, we give the advice not to meddle with any machinery you know nothing about. Such persons as Stewart and Lord & Taylor do not need any machinery of order slips and tickets and such "gumgoolery" to do their immense business. If these "C. O. D." chaps are doing a straightforward business, why don't they do it in a straightforward way? The boy knew the hole the woodchuck went in at, but couldn't tell which one he'd come out at. And so we fear it will be with money that goes in to any of these dubious enterprises.

MEDICAL HUMBUGS

present few new features. One person writes to ask our opinion of "Uncle Ber Joe's Bell Tongue Syrup." We disposed of "Old Uncle" months ago. The strangest part is that any one should ask our opinion about any quack medicine whatever. All these things that are advertised are useless or worse, and the chaps who advertise them are quacks or worse. So with eye-cups and ear drums. It is of no use to ask us if the advertisers of these are reliable men. We neither know nor care. If any one wishes to tinker with his own eyes or ears, about the internal structure of which he knows nothing, he will not do it with any aid of ours.

Seed Potatoes.—"S. T.," Marion, Ind.

We have raised the largest crop of potatoes when we cut the seed to single eyes and planted two sets to a hill, hills (for Early Rose) thirty inches apart. The plan, however, will not answer so well for all kinds. The Peachblow cut in the same way has yielded with us very much less than with two sets of three eyes each in a hill.

We have frequently planted sets cut from very small potatoes without finding any difference between the yield and that from sets from large potatoes. But when the small potatoes have been planted whole and not cut as the others were, the yield has not been so good. Nevertheless we would always prefer to plant seed from fair-sized, well-formed, perfect potatoes. Liquid manure may usefully be applied while the crop is young.

Homesteads.—"Wallie." A soldier may take a homestead of 160 acres within the limits of a railroad grant, or ten miles upon each side of the road, but any other citizen may only take eighty acres within it. He may, however, take 160 acres outside of the grant, while a soldier can take no more anywhere. The fees for homesteading are \$14. Any person may pre-empt or purchase not more than 160 acres anywhere, but within a railroad grant the price is \$2.50 per acre or double what it is outside of it.

Spelt.—"J. A. M.," New Ulm, Minn. Spelt (*Triticum spelta*) is not wheat, although it belongs to the same botanical genus. It is an inferior grain weighing only thirty-six to forty pounds to the bushel, and because it thrives upon soil where wheat will not it is grown in some of those European countries where the agriculture is somewhat backward. The reason it is not grown here is because there is no demand for it in the grain markets, and if a crop were raised it is doubtful whether or not it could be disposed of. Rye would be a more profitable crop upon soils where wheat would not succeed. But instead of looking for crops suitable for poor land, it would be wiser to improve the soil and raise the best crops possible. There are spring and fall varieties of spelt as there are of wheat or rye.

Poland China Hogs.—"J. D.," Middletown, Del. The Poland China hogs are a large breed best suited to the Western states or in places where rapid growth and large size upon abundant food is desired. On reference to the advertising columns the names of breeders from whom they can be procured will be found.

Sycamore Timber.—"Subscriber," West Va. The wood of the sycamore tree (*Platanus occidentalis*) is better fitted for furniture or other purposes in which it is used in-doors and is not exposed to the weather than for out-door use. By exposure to the weather it twists and warps very much. It is not a durable timber when exposed to damp, as when buried in the ground for drains. The cucumber tree (*Magnolia acuminata*) would furnish much more durable timber for drains, and the chestnut or chestnut oak and white oak would be far better for fence posts, boards, or palings.

Excelsior Lawn Mower.—"Subscriber," Woodbury, N. J. A lawn can not be kept smooth and neat without the use of a good lawn mower with roller attached. The machine referred to is an excellent one, and has the gearing all inclosed so that it can not clog with the cut grass. It is made by the Chadborn & Coldwell Manufacturing Company, Newburgh, N. Y.

The Gardener's Monthly still remains a puzzle to us; its course is quite beyond our comprehension. In its March number it made a statement in regard to the *Agriculturist* that was so wrong that we felt called upon to set it right, and supposed we had done so in a pleasant manner in our paper for April. To this article the Gardener's Monthly for May makes the following rejoinder, which is as far out of the way as its original statement, and while we have no disposition to continue a discussion which our cotemporary is disposed to treat as if it were a quarrel, it is only just to ourselves that we deny those things of which it wrongly, and we are quite sure mistakenly, accuses us. The following is the Monthly's article:

Boussingaultia Lachauxii—The *American Agriculturist* devotes a column and a half of small type to abuse of the Gardener's Monthly. (1) For pointing out the fact that what the *Agriculturist* Company, in a recent issue of a "list of wood-cuts for sale," calls *Boussingaultia Lachauxii* is nothing but *Tulium patens*. (2) It acknowledges that we are right in the correction; but says that Donald G. Mitchell made the mistake first in the *HEARTH AND HOME*. (3) It elegantly says that Mr. Mitchell can settle this with the "G. M., which may mean either Grand Mogul or Gardener's Monthly," which ever the reader pleases. (4) It is not clear to us why a mistake which "originated in the *HEARTH AND HOME*" (3) should be continued in a catalogue of Orange Judd & Co. years after Donald G. Mitchell's time; and only that we deprecate the use of abusive language in the discussion of such innocent questions (5) as these, we might, slightly altering our cotemporary's expression, say that "Mr. Mitchell can settle this with the A. A., which may mean Arrant Ass or *American Agriculturist*." (7)

To this we reply: 1. We are quite surprised that the Monthly should look upon our article as "abuse." We too well appreciate the good work that journal has done and is doing, and have too high a personal regard for its

editor to treat it to anything like abuse. We totally disclaim in the article referred to any other feeling than that of the greatest kindness and good-nature. It placed us upon record as having said something which we did not say, trusting to an impression rather than positive knowledge. We acquitted it of all wrong intent, and we refuse to be considered as abusive. . . . 2. There is not, to our knowledge, any such organization as the "Agriculturist Company." The Orange Judd Company did issue a list of wood-cuts for sale, and the name *Boussingaultia Lachauxii* does not occur in it. This is a simple difference as to a fact, and we trust that this statement may not be regarded as "abuse." . . . 3. We are at loss to see how our language could be construed to read thus. "We did not say it. . . . 4. This is put in quotation marks as our language. We did not say so. It is an error of quotation. As the gravamen of our article seems to be in what was intended to be a playful use of the initials, which we supposed the editor would laugh at, we unqualifiedly retract the expression "Great Mogul," and, if it will better satisfy it, will say that it is in no sense either "Mogul" or "Great." . . . 5. Here is another quotation, but no such words occur in our article. It is safer not to quote from memory. . . . 6. We agree that it is an innocent question, yet it is a question of fact. We were positively charged with giving to a plant a name which we did not give. We denied that we used the name editorially. Now it is charged that it is used in a business advertisement. Having examined this catalogue, and not finding it, we are obliged to deny its existence there. If it is abusive to deny it we are sorry. We charge our friend with no ill intent, only a singular misapprehension; and we in our first article, as distinctly as language will allow, acquitted him of "wilful misrepresentation." . . . 7. "This reminds us" of an occurrence in the Rhode Island legislature many years ago, when T. W. Dorr (afterwards known as "Governor" Dorr) first entered public life. In a discussion with blunt Mr. H., a farmer representative old enough to be his father, Dorr exhausted all his rhetorical resources in an elaborate invective against old Mr. H. When H. arose to reply the assembly, knowing his power when aroused, were in expectation of seeing Dorr completely demolished; the old man, however, pointing his long, skinny finger at Dorr, said, "Mr. Sp-aker, 'taint pooly, 'taint pooly," and took his seat. As our friend J. B. would say, "the bearings of this observation lays in the application on it."

The Planet Drill.—Among the many machines for sowing seeds and distributing fertilizers, the "Planet," made by S. L. Allen & Co., Philadelphia, is quite different in principle from any other we have seen. Up to the present time of writing the weather has been too unfavorable for a thorough trial of the machine, but we have used it with some of the seeds most difficult to sow with a machine, and find it to work excellently, and have no doubt that it will improve upon acquaintance. One of its merits is its great simplicity.

Underground Poultry Houses.—"H. M. S.," Northfield. Upon page 216 of the present number will be found an engraving and description of a poultry-house partly underground, which we know answered its purpose very successfully. But the soil was a very dry gravel, and we should doubt if a similar house in a damp clay soil would answer at all. Fowls can not live in damp places, and a dry situation is necessary for them, especially if they are to live in a cellar.

Young & Elliott.—This well-known firm of seedsmen and florists are removing from their old place in John street to a fine large store No. 12 Cortlandt street, the same in which their plant auctions have heretofore been held. It is rather late to mention the fact, but we would say that the auctions held each spring and fall by this house are an important feature in the plant trade of New York. They receive consignments from florists and nurserymen and plant collectors from far and near, and their auction room is an important exchange for dealers, and not without its attraction for mere sight-seers; indeed, their place is often as interesting as a horticultural exhibition.

Farm Scales.—"J. W. B.," Chester Co., Pa. The farmer who never weighs or measures must certainly lose considerably in the course of a year. The small cost of a platform scale suitable for farm use would soon be saved, and the economy would appear in many ways. The Fairbanks platform scales have a good reputation for accuracy and durability, and they can be procured in almost every considerable village in the country.

Production of Potatoes.—"G. W. A.," Milton, Pa. According to the census of 1870 there were raised in the United States in that year 143,937,473 bushels of potatoes and 21,709,824 bushels of sweet potatoes.

As to Pigs and Pork.—"Subscriber," Sanilac, Michigan. Pigs, unless greatly infested with trichina, show no symptoms of the parasites during life. When badly infested they sometimes suffer from stiffness of the limbs and partial paralysis, but a pig estimated to have sixty millions of trichina in its muscles has shown no symptoms during life. When the flesh has long been infested the cysts or envelopes of the parasites may be seen upon close examination by the unaided eye as small white specks. Infested meat may be eaten with perfect safety if it has been exposed thoroughly to a heat of 212°, the temperature of boiling water. Only pork that is thoroughly cooked can be eaten with safety. The yellow color of the fat of pork is caused by a disordered condition of the animal's liver consequent upon overfeeding during fattening. It is not considered unwholesome and is a parallel case to that in which the flesh of sheep becomes yellow when the disease known as "rot," a liver or bilious disorder, is just beginning. In this condition they fatten very rapidly.

A Great Sale of Horse Stock.—We much regret to hear that the magnificent establishment of the Kansas Stud Farm near Lawrence, Kansas, is to be sold. The senior partner of the firm of Messrs. Sprague & Akers, the Hon. Amasa Sprague, of Providence, R. I., by reason of financial reverses has found it convenient to dispose of his interest. Two hundred and fifty head of stallions and mares descended from the best stock in the country, including Ethan Allen, Rhode Island, St. Elmo, Comus, Erie, and others will be brought under the hammer. The sale at Lawrence, Kansas, commences on the 3d of June, and a sale of equal interest hardly occurs twice in one's lifetime.

Dipping for Scab.—"J. S.," Downingtown, Pa. A method of dipping sheep or lambs is shown in the *Agriculturist* for May, 1873. The sheep dip used for the scab, Buelhan's carbolic dip, may be procured of the Orange Judd Company, 245 Broadway, New York, in packages sufficient for fifty sheep for \$3.00, with directions for use. The sheep had better be shorn before dipping, and afterwards kept in a stable if the weather is cold. The dipping ought to be repeated in two weeks. It will be necessary to rub and break the scabs with a piece of coarse cloth or blanket dipped in the liquid, as the scab insects burrow beneath it.

Three Horses Abreast.—"W. H. M.," Montgomery Co., Pa. When three horses are used to a plow the central line of draft must come in a line with the furrow that is being plowed; otherwise the draft is greatly increased and the side draft must be overcome by great exertion of the plowman. But the side draft caused by the extra horse may be partly overcome by using a draft rod from the side of the beam near the standard, gradually extending outwards from the left on the land side of the beam, and connected with a draft plate projecting from the end of the plow beam on the left sufficiently to bring the inside horse into the furrow.

Turpentine for Crows.—"W. T. G.," Chatham Corners, Canada, says that common black bottles each containing half a pint of spirits of turpentine, hung from stakes driven in the cornfield so that the turpentine can be smelt by the crows in all parts of the field, will frighten them away. If the seed is dipped in common tar and rolled in plaster or dry sand before planting, the crows will not take it.

Male or Heifer Calves.—"J. A. C.," Dover, N. J. The accident of the sex of a calf is one which we can not control. Any person who offers to sell a secret whereby it may be controlled for \$1 or any other sum is either a knave or a fool. A breeder may very easily have ten c. calves this year to one b. calf, but next year the proportion will probably be reversed. On referring to the writer's record of seventy calves born in five years we find 37 c. calves and 33 b. calves, and one of the cows had c. calves each year, while another never had a c. calf at any time. From experience and observation as well as on general principles, we have no faith in any method or plan to produce either sex at will.

Value of Grade Jersey Cows.—"F. M. N.," New Bedford, Ct. Grade Jersey cows that will make two pounds of butter a day should be worth \$150 each. If they were pure bred they would be worth \$300 to \$500, according to their "points" or general appearance. This is not an idle or worthless distinction, as some would maintain, for the reason that animals which breed true to color or "points" may be depended upon to breed true to quality as milkers; and a cow that throws a wild-colored calf may also throw a poor milker, although she may be an excellent milker herself. For this reason a self-colored cow, with all the

marks that are called "fashionable," and which produces calves like herself, is valued at double or treble the price of other cows.

Cotswolds or Leicesters.—"W. P. T.," Clearfield, Pa. Our experience with these sheep is in favor of the Cotswold as hardier and altogether better than the Leicester. We would rather breed for early maturity than for excessive size, and would choose a moderate-sized ram with good, close, heavy fleece rather than a very large one with an open, light fleece. We would also rather use a good Cotswold ram, although he was the sire of the ewes, than a Leicester ram that we did not approve of. One such cross might not be objectionable with sheep if it could not well be avoided.

The Cause of Chicken Cholera.—"Farmer's Wife," Franklin Co., Ohio. We do not think the introduction of foreign fowls is the cause of chicken cholera. The foreign breeds are no more subject to disease than any others. Besides, what breeds have we that are not originally of foreign origin? The cause of cholera is undoubtedly lack of attention to cleanliness, warmth, and to a proper diversity of food, and want of pure water.

Poultry Raising.—"D. K. R.," Shelbyville, Ky. The best time to commence keeping poultry is in the fall or early winter. At that time young hens can be purchased readily. In the spring farmers' wives are not anxious to sell their fowls. If they are fed well and a warm place provided, some of the hens may be set in February or earlier, and some early broods may be hatched out and sold for early chickens. On eight or ten acres 500 fowls might easily be kept, or if skillfully managed double that number. One variety would be found most profitable, unless fancy poultry were kept, when of course there must be a separate house and yard for each kind. A change of roosters should be made each year.

Contraction of the Hoof.—"J. H. D.," Adams Co., Ohio. Probably the best thing to be done in a case of contracted hoof is to fit a set of the Good-enough shoes to the feet without any paring or rasping, to leave the frog and bars altogether untouched, and to depend upon nature to restore the sound condition of the hoofs, which has been destroyed by wrong treatment. Rasping the hoof and cutting away the frog and bars are the chief causes of contracted hoofs, and this injurious practice should be discouraged. The hoof may be occasionally washed with cold water and anointed with glycerine. Tar should not be smeared upon the hoofs.

Hog Cholera.—A. G. Wallace, of Tuscola, Ill., recommends the following as a feed for hogs when the cholera is raging: Use two swill barrels. Mix a feed of bran, shorts, or middlings, and water and feed only after fermentation. This mixture soon becomes sour standing in the sun and is devoured eagerly by the hogs. Feed once a day through the season when hogs are most likely to have the disease. By using two barrels, and mixing in one in time for fermentation to take place before the supply is exhausted in the other, the same degree of "sourness" is maintained. He has fed this regularly for five years in the cholera season, and has not lost a single animal. Others who have tried it have met with the same success. Mr. Wallace has in the same time lost no chickens or turkeys by disease, and he attributes their freedom from disease to the use of the fermented food. The cholera has made sad havoc among the hogs in Central and Southern Illinois this season, and as all the old preventives and remedies have failed, the very simple one above given may prove of value.

Wool-bearing Goats.—"P. H. W.," Washington Co., Md. The Cashmere goat is the wool-bearing goat. The wool or down grows beneath the hair and next the skin, and is very fine and valuable. It is the material of which the costly Cashmere shawls are made. We do not know of any of these goats in this country. The Angora goat, although frequently called the Cashmere by people here who raise them for sale, is a different animal altogether, and comes from another and a distant locality. Its fleece is of long hair and is used for various small manufactures, such as trimmings. The market value is from 30 to 80 cents a pound. We do not recommend persons to keep goats where and when they can keep sheep, because they are not so docile to manage, are not so profitable, and are equally subject to disease, death, and destruction by dogs.

The Most Profitable Stock.—"Subscriber," Poughkeepsie, N. Y. It is impossible to say definitely what breed of cattle may be made most profitable to raise for selling. There is no one breed that holds any pre-eminence position, and the choicest specimens of any breed are sought for by the fanciers of that particular

stock as eagerly as those of any other breed by their fanciers. It is a question of capital and skill altogether. The breeding of Short-horns would require more capital than would the breeding of Jerseys, Ayrshires, or Devons because they cost more and need more costly care and attention, and the risk is greater. The price is proportionately higher, but the profit is no greater than with less costly stock. If there is any choice of breed so far as ease of keep and readiness of sale at remunerative prices are concerned, the Jersey, Ayrshire, or Guernsey stock might probably be the best.

Galloway Polled Cattle.—"D. W. C. II.," Clifton, Ill. There are breeders of Galloway cattle in Michigan and in Canada, but as we have not their addresses at hand we can not give them. The number of inquiries which come to us for the names of breeders of these cattle suggests the propriety of their making themselves known in the usual manner.

A Yearling Jersey Bull.—"A. J. W.," Broome Co., O. "A large and vigorous yearling Jersey bull" may be allowed to serve about a dozen cows; but he should be fed a quart or two of meal a day in addition to his regular feed. A Jersey heifer may be bred at twelve months without injury. This breed is remarkably precocious, and has been bred purposely to produce this condition.

Big Head.—"A. B.," Cass Co., Iowa, and others. The disease in horses known as *osteoporosis*, or "big jaw," or "big head," is incurable. Its seat is in the bone, which can not be removed without destroying the horse.

Breeding Mules.—"M. A.," Florence, N. C. The best mules are bred in Kentucky, and it is not uncommon to find teams there sixteen hands high and weighing 1,400 pounds each. Although occasionally there are larger mules, even as high as eighteen hands, such are rare and undesirable. The use of mules is rapidly increasing in this country, there being over 1,150,000 in use in 1870, against 570,222 in 1850. When properly and kindly used the mule is not the vicious animal it is generally supposed to be, and it is a mistake to be prejudiced against it on that account.

Remedy for Foot Rot.—"J. H.," Lime Ridge, Pa. The best remedy for foot rot is to pare away all the loose horn and dress the diseased parts with muriatic acid. When the fungoid growths have been thus destroyed the foot should be washed in a solution of two drams of chloride of zinc in a pint of water, and if there are any holes in the foot they should be plugged with tow soaked in the solution until they heal.

Keeping Sheep for Health.—"Reader.," East Tennessee doubtless offers some advantages to a seeker after health and profit together in keeping sheep. But the Western plains would be found equally healthful and far more profitable, as pasture is practically free and unlimited in extent. The whole capital could therefore be expended in purchasing sheep, and no land need be bought for many years.

Diarrhea in Calves.—"C. A. N.," Dunville, N. J. Diarrhea in yearling animals exists as a symptom of disease rather than as a disease of itself. It may indicate the presence of worms or other irritants in the intestines, or it may accompany disorder of the liver or of the blood. Without knowing anything but the simple fact of the complaint it is difficult to say what would be the best treatment. It would be safe, however, to give only the most digestible food and no fresh green fodder. Good clover hay cut and mixed with some fine middlings or millstuff and a handful of linseed meal, and the whole scalded and given in moderate quantity when cold would be beneficial. Three ounces of epsom salts, two drams of carbonate of soda, and two drams of ground ginger may be given in half a pint of slightly warm water. After this has operated one ounce of tincture of rhubarb, an ounce of tincture of cardamons, with one dram of carbonate of soda may be given in half a pint of water, and a tablespoonful of molasses, once a day for a few days.

Baling Hay for Market.—When a person buys a bale of hay, it is supposed that he trusts something to the honesty of the person who packs it. This is a great and sad error. It may contain chaff-dust or damaged hay, but the farmer who packs the bale is really the one who suffers. It is a sad reflection that not even a bale of hay is taken on trust any more, and the shipper who has not made a reputation for honesty, although his bales may be perfect in every respect, can not hope to get a top price for his produce. The risk of his dishonesty is discounted by the dealers, who have to

suffer the loss, and it is only when he has become known and has made a reputation that he can hope to get full value for his hay. It is strange that even now there are men who suppose purchasers in cities will pay two cents a pound for sticks, and therefore they ornament their hay bales with stout ones at each corner, which are worse than useless, because they are a standing reproach against the honesty of the farmers who make the bales. The guilty packers do not suffer alone, but cause innocent parties to lose as much as they do. If they only knew that these tricks are unavailing, and that they only cheat themselves, they might act on the principle that honesty is the best policy.

As to Merino Sheep.—"Ohio." The difference between the several varieties of merino sheep consists in the quality of the fleece, and to some extent in the weight of carcass. Some varieties have finer wool than others, and some longer wool; there are also differences in the amount of yolk or grease contained in the fleece. The improved American merino claims to combine the excellences of all the foreign varieties, but although this may not be justified by the facts yet it is a good enough sheep for all our purposes when carefully bred.

Chicken Cholera.—"E. D.," Clinton, Kansas, says after losing 100 chickens by cholera he found that a table-spoonful of soda mixed with a quart of milk and given with the food was a cure.

Ayrshires for Beef.—"G. S. A.," Lincoln, Neb. The Ayrshire ox is an excellent worker and a good beef animal. The Ayrshire cow, upon good feed, is as good beef as the Devon cow, while she is much superior as a milker. Where beef and milk are both wanted, the Ayrshire or perhaps the Dutch cattle would be the best upon your prairies where the feed is good and nutritious.

Selecting Eggs for Pullets.—"J. R. K.," Mendocino Co., Cal. During many years we have made many experiments in selecting eggs for hatching with the purpose of observing whether one kind or another would produce pullets or otherwise. We found that eggs produced one or the other sex of chickens irrespective of their size or shape, and that the shape of the egg depended upon the hen that laid it, and not upon what it contained. Out of a flock of 300 hens we soon learned to distinguish the eggs of a large number each one of which laid eggs of a peculiar and uniform shape, size, and color, and a setting of eggs of exactly the same character in every way so far as it could be discerned produced the usual proportion of male and female chicks.

The Best Sheep.—"S. B. B.," Dover, N. H. A selection of sheep should be made altogether in reference to the locality and the character of the farm upon which they are to be kept. Upon hilly, poor land the Merino sheep or its grades would be the best; upon hilly but rich pastures the South-Down, the Cotswold, or the Shropshire sheep would be suitable; low, flat lands are unsuitable for sheep of any kind.

Metallic Ear-Mark.—"L. M. K.," Adams Co., Iowa. The best metallic ear-mark we know of is Dana's, described in *May Agriculturist*.

Shipping Eggs.—"California." If shipping eggs for market is meant, there is no better way than to pack in barrels with cut straw or chaff. A flour barrel will hold sixty to seventy dozen, and if plenty of packing is used and the head tightly pressed down the eggs will stand much rough usage safely. Eggs for hatching should be packed in dry wheat bran in a light box, which should be again packed in a larger box with plenty of dry straw between the two boxes.

Feeding Meal Wet or Dry.—"J. H. D.," Stouts, Ohio. The most economical way of feeding meal is to mix it with a little cut hay, straw, or roots. Feeding it dry and alone is a wasteful practice, because some of the meal is not digested, and is therefore lost.

Roof for Root Cellar.—"E. M. S.," Worcester Co., Mass. The most perfect roof for a root cellar is an arch of brick laid in cement and covered with a coat of asphalt or gas-tar.

Patent Butter Firkin.—"G. B.," Oneida Co., N. Y. We can not say whether there is any patent upon a butter package which is narrower at the bottom than at the top, or not. There are too many patents for any person to keep the whole of them at his fingers' ends. But if there should be it is infringed every day of the year, and has been for many years back, and by thousands of people, for such butter pack-

ages are more commonly used than any other. The Orange Co. butter pail is just such a package, and there is nothing to prevent any person using such a one.

The Mole Plow.—"J. N. S.," Pendleton, S. C. A good lifting subsoil plow would probably be of better service than a mole plow in any other soil than a clay. The subsoil plow will break up the hardpan, and if the ground beneath is not very retentive of moisture, that is often sufficient to dry the surface without draining. Draining is not always and everywhere required, and is sometimes an unnecessary expense. The mole plow acts best upon clay soils, and there its effects are visible sometimes for three or four seasons, after which it needs to be used again.

Steamer for Feed.—"G. L. W.," Shreveport, La. In another column of this number of the *Agriculturist* there is described a steamer or boiler with which we have been acquainted for several years, and which perfectly answers the purpose of steaming feed. For twenty cows the interest on the cost of a boiler and small engine for cutting the feed could be saved many times over each year. In the *Agriculturist* of January, 1873, will be found a description, with engravings, of a good form of steam chest.

Horse Power.—"J. N. S.," Pendleton, S. C. The Harder railway horse power is considered a good one and with a pair of good-sized mules will be able to run a threshing and cleaner or a cotton gin. A bull of good size would run such a horse power for doing light work. We never found the east-iron endless chain upon railway powers any trouble. With each machine some spare links should be sent, and if one is broken it can be replaced. The broken one may be used as a pattern whereby to cast others. It is strange that you do not see advertisements of these horse powers: they appear in our columns almost every month, and the makers of each kind are trustworthy and responsible parties.

The Scotch Plow.—"W. H. S. G.," Chattanooga Co., N. Y. The plow figured in the engraving on the first page of our April number was made by Gray & Co., Scotland, and was imported by Mr. Wm. Crozier, of Beacon Farm, Northport, Long Island, for his own use. We have no doubt that Mr. Crozier, who is extremely obliging to his brother farmers, would willingly order one for any of our readers who desire it and will communicate with him.

Fumigation of a Meat-House.—"G. M.," McMinnville, Tenn. When a meat-house is infested with the meat-bugs or weevils, a good fumigation for a whole day with sulphur would probably destroy the vermin. The meat should be removed during the operation, for although it would not be injured, yet it would acquire an undesirable flavor.

Three-Horse Clevis.—"T. J. L.," Indiana. The clevis of which you send a sketch is a patented one, and any person using it is liable to pay the patentee a royalty for its use or be called upon to defend a suit. As to the justice of the patent we of course can not give an opinion, but we know that the same contrivance has been in use in Great Britain for many years, and we believe it has also been in use in this country long before the patent was issued. This is not the only patent upon which farmers are called to pay for rights to use devices which have been in use for years before some person was granted a monopoly of them by the patent office.

Iron or Wooden Axles.—"B." The advantages of the iron axle over the old-fashioned wooden ones are chiefly its greater strength and durability, and the less risk of losing the lynch pin and parting with the wheel. An iron axle runs somewhat easier in a wooden box than in an iron box. There is no practical difference in the draft whether the axle is small or large.

Feed Barrow.—"D. P.," Otsego Co., N. Y. The axle of the feed barrow shown upon page 16 of the *Agriculturist* of January, 1874, is formed of two small flanged gudgeons which are bolted to the sides of the barrel. The handle of the barrow is made to fork, and at the end of each fork a hole is punched, through which the gudgeon passes before it is put into the hub of the wheel and pinned to keep the wheel on. The pin is a common spring lynch pin. Or the axle may be a hoop which encircles the barrel at the middle.

Getting Rid of Stones.—"Evergreen Farm," Ct. It would be a good plan to dig drains in a wet meadow forty feet apart, three feet deep, and eighteen inches wide at the top, and twelve inches at the bottom. The drains may then be filled with stones, selecting the largest for the bottom of the drain, and placing them so

that one large flat one is laid upon two smaller ones, thus leaving an arched or covered channel. The smaller stones are to be laid upon these up to a foot from the surface, which will prevent them from being ever disturbed by the plow. If the ground is very wet and springy it would be better to dig the drains four feet deep or thirty feet apart. Although tiles are better than stones for making drains, yet when the stones are at hand and must be got rid of they may profitably be disposed of in this way. If carefully placed in clay soil the stone drains will last many years.

Breast Strap or Collar.—"E. A. B.," Newark, N. J. A horse can draw better in the ordinary collar than with the breast strap. The collar has a bearing upon the shoulders as well as upon the breast, and if it fits well there is no pressure upon the throat. The breast strap having much less bearing is more apt to bruise or press upon the throat when the draft is heavy.

As to Wells.—"A. J. D.," Ottumwa, Iowa. There is no need to go to the expense of making a well so large as is usually done. If water is within 20 feet of the surface the drive may be used with a tenth part of the cost of the ordinary well. But for stock wells and where a larger well is wanted, or where rock has to be passed through, the Jilz anchor well may be put down with a bore of from 6 up to 20 inches at a cost of about a dollar a foot with tubing, etc., complete. If such a well with a wind pump attached were to be put down at the corner where four farms or fields join, at the joint expense, much money might be saved. But farmers, for some reason or other, do not avail themselves of this plan of co-operation as much as people who live in towns or villages do, or as much as they might very usefully do.

Straw-Preserving Thresher.—"A Subscriber," Clinton Co., N. Y. The machine you require is the improved straw-preserving thresher, made by the Wheeler & Melick Company, Albany, N. Y. There are no spikes in the concave or cylinder to break the straw, and the straw is delivered sidewise along a traveling bed on to a horse where it may be bound in even bundles like hand-threshed straw.

Baling Hay.—"A Farmer," Augusta Co., Va. There is no necessity for making hay bales so large as 300 pounds. One hundred pounds is a more convenient size, and the hay may be pressed just as close in such bales as in large ones, and lighter ties will answer. P. K. Dederick & Co., Albany, N. Y., manufacture an improved press in which bales of any size from 100 pounds up may be made, either of long hay or of cut hay.

Tar-Paper for Poultry Houses.—"G. P. A.," West Haven, Ct., writes that he built a poultry house three years ago and lined it as well as the nests with the common tarred roof paper, wrapping the ends of the roost also with the paper where they were fixed to the wall. As he has not yet seen any lice upon the fowls he believes the tarred paper to be a preventive.

Butchers' Offal.—"D. B.," Champaign, Ill. The readiest mode of utilizing butchers' offal is by spreading it upon the ground and plowing it under. After a time a cross-plowing will mix it pretty thoroughly with the soil.

Frost-Proof Fruit House.—"Stewartsville," Ind. A double-walled frame building with a space of a foot filled with chaff between the walls would not be warm enough to keep fruit from freezing in very cold weather. An earth-protected house such as is shown in the *Agriculturist* of October, 1873, would be frost-proof if properly constructed. There should be at least two feet of earth over it and an air space between the outer wall and the lining.

Old Hay.—"Farmer," Danielsonville, Ct. It will be no injury to good hay to keep it until the second year. Many people believe that hay is better feed when over a year old than new hay, at least for horses.

The New Timber Act.—By the provisions of the new act relative to timber culture in the prairie states, a person who homesteads 80 or 160 acres, and has filed his claim, is not prevented thereby from acquiring 160 acres under this act. Any person who is the head of a family, or is twenty-one years of age or over, may take up a quarter section of land for timber planting. There are still many tracts of government land open to settlement in Kansas, Nebraska, and Minnesota, but they are distant from railroads; and on the whole for a person who has the necessary money it will be found greatly more profitable to pay five dollars or six dollars an acre for land near a town and railroad depot than to take land for nothing ten or twenty miles away from it.

Paris Green.—D. Rex asks "if Paris green is a safe remedy for insects upon every kind of plant and which is the best way to apply it?" We should not advise its use upon salads, cabbages, or any other plant the foliage of which is to be eaten. One part of the green, provided it be pure, mixed with twenty parts of flour, is sifted upon the foliage when wet with dew from any convenient tin box with perforated cover. For small operations a wide-mouthed bottle like a quinine bottle with muslin or other open fabric tied over the mouth will serve. Keep to the windward and avoid breathing the dust, and keep the poison always where no accident can occur. It is found that the poison is so neutralized in the soil that no danger can arise from its being introduced into the system of the plant.

How to Feed Salt.—"G. H. A.," North Conway, N. H. The plan of keeping rock-salt before horses and cattle continually is a very good one, but it has some inconveniences. Our plan is to have a barrel of salt in the feed-room, and to scatter a handful upon each bushel of feed as it is cut and moistened in the feed box. In summer time an equal amount of salt is scattered along a trough in the yard daily.

Tomatoes Dying.—"A. N. S.," Savannah, Ga., reports that in Effingham Co., Ga., tomato-plants grow well enough until the fruit begins to ripen, when the whole plant dies down suddenly, and asks us to prescribe a remedy. The first thing we should do in this case would be to carefully examine the root and ascertain whether any insect, large or small, is the cause of the trouble. Should no insect enemy be found we should then try what effect pruning would have. It may be that plants allowed to grow at will set more fruit than can be ripened, and in the rapid swelling of a large quantity of fruit more nourishment is demanded than the root is able to supply. We shall be glad to hear more of this.

Clematis from Seed.—"Mrs. A. L. R.," The best way is to sow the seeds as soon as ripe in a box of earth, and if the plants do not appear the same season, keep the box in a cold-frame over winter and they will be very likely to start the next spring. If no cold-frame is at hand cover the box with boards to keep the storms from washing the earth.

Late Crop of Turnips.—"W. W.," Baraboo, Wis. Rutabagas may be sown with safety as late as the first week in July; they will, however, be better if sown in June. A good crop of white or yellow turnips may be taken from an oat stubble if the ground is in good order and the seed is sown by the first of August or soon after. The best fertilizer after barnyard manure for any root crop is superphosphate of lime or fine bone-meal.

Why they do not Lay.—"C. F.," Detroit, Mich. Fowls will not lay unless they have exercise. A coop five feet by four, and only three feet high, is much too small for a single fowl, much less for seven. A run fifteen feet by four is also insufficient. If the fowls are turned out they will probably begin to lay very soon. They should also have a roomy, airy place to roost in. It is probable that fowls kept up so closely, and well fed, are overloaded with fat, and possibly are infested with lice.

How to Secure a Calf.—"S. W. J.," Fordenskeld, Minn. It has long been a custom when a cow failed to breed to drive her some miles to a hull, and the plan is generally successful. Recently an Irish breeder followed this plan with some Shorthorn cows which had failed to breed for several seasons, and they all became in calf. The ancient poet Virgil speaks of a similar practice as being in use in his day, and also of reducing the quantity of food and the condition of the animal—cow or mare—as a means of procuring fertility. We know of no modern practice that is so effective as these old ones.

"Beautiful Moral but Bad Botany" is the heading of an item in the New York Weekly Tribune. That the paper can judge of a moral we do not care to dispute, what its practice in morals is we shall briefly show, but for it to pretend to judge of botany of any kind, good or "bad," is simply too laughable. In that strange medley which the Weekly facetiously terms "agriculture," there have been some absurdities to which we have good naturedly called its attention. This has set the Weekly to hunt up something in retaliation, and naturally enough it went into the juvenile department, and in the pages of 1868, with the aid of "A Correspondent," it found a "tender, sweet little story" which involved a botanical question, and paraded it in its columns as the opinion of "the Editor of the *Agriculturist*." The editor of the *Agriculturist* never

saw the article before, and is no more responsible for it than he is for the absurdities which appear in the Weekly Tribune. He, however, has his opinion of that kind of journalism which will descend to making an error of the head of a distinct department, made several years ago, appear as his opinion. The "moral" may be "beautiful," but the *morals* which will bring up an obsolete affair as an opinion of to-day, and state it is from the *American Agriculturist* without reference to date or place are of a kind we do not care to qualify. Anything more microscopically small has not occurred in our editorial experience.

Population and Industries of Kansas.—We have received through the kindness of Mr. Alfred Gray, secretary of the Kansas State Board of Agriculture, some extracts from the annual report of that institution for 1873. The exhibit of the present condition of this young but rapidly growing State is very favorable. The population of the State is now over 605,000, against 364,000 in 1870 and 107,000 in 1860, a vast growth in thirteen years; and to this should be added the population in twenty-nine counties which are not yet organized. The increase in productions and in material wealth is equally striking, and shows that those who have made this State their home have gone there to work, and that their industry has been crowned with success. The report is worthy the study of those who are interested in the affairs of that State.

Ditching Machine.—"A Western Farmer," Springfield, Mo. The Carter improved ditching machine cuts a drain three feet deep and a foot wide, leaving the earth in a ridge at one side. With four horses and two men from 3,000 to 5,000 feet of drain may be dug in one day. The machines are made in St. Louis. We have seen the machine doing excellent work in heavy clay soil free from stone. Large stones would be an insuperable obstacle to its use.

Peruvian Guano.—"Market Gardener." The quality of guano is variable, being frequently adulterated, and to procure it genuine it should be purchased of some trustworthy dealer. It can be procured genuine as imported, in small or large lots, of R. Balcazar, 53 Beaver street, New York, who is the special agent of the consignees of the Peruvian government.

Cutting and Grinding Corn-Stalks and Ears.—"L. D.," New Iberia, La. We have found it easy to cut corn-stalks, with ears unhusked and in the sheaf, by using a Telegraph fodder cutter run by a two-horse tread power worked with one horse. The ears and stalks are cut into slices from a quarter to half an inch thick. If the fodder is then steamed it is eaten clean by cows, oxen, or calves, and would be so undoubtedly by mules. If, however, it is desired to make the fodder still finer, a Little Giant cob-crusher would reduce it to coarse chaff. Two-horse power would be sufficient.

Potatoes, New and Old.—"Subscriber," Goshen, N. Y., thinks that our correspondent at "The Pines" in calling Vermont the "mother of potatoes" overlooks the claims of New York State and the labors of Mr. Goodrich in improving the potato. We are quite sure that the gentleman referred to gives full credit to Mr. Goodrich, to whom we are greatly indebted for having started the race of potatoes which finally culminated in the Early Rose and other choice sorts. Had it not been for Mr. Goodrich's labors we should have had no Early Rose, and it is to be regretted that he died just as his work was on the eve of manifesting its usefulness. Our Goshen correspondent says of potatoes in his vicinity: "We have produced some new seedlings, both early and late, from the Early Rose. They are very good, and the public are beginning to look after them. The 'Carpenter's Seedling' has become quite popular as an early variety. Next in season (some later) is the 'Ice Cream.' Very productive, and of superior quality. For the main crop, taking the place of the Peachblow, it is likely to be a particular favorite, especially with the West, on account of its being almost exempt from the ravages of the Colorado beetle. The 'Lawrence' is another variety, only two years from the seed. It has not been thoroughly tested. It is very promising; a handsome potato in appearance."—Our correspondent has obligingly furnished us samples of these, which will be tried with numerous other new and as yet unfamed sorts.

Catalogues, Pamphlets Etc., Received.

MAHLON MOON & SON, Morrisville, Bucks Co., Pa. We have perused this catalogue with much interest, as it contains, besides the usual plants kept by florists, a number of good old things, things that one rarely meets with, and all at most moderate prices. It is a pity that

so good a catalogue had not received more careful proof-reading.

BRIGGS & BROTHER, Rochester, N. Y., issue their catalogue as a quarterly, and the April number is beautifully illustrated, and contains many items of interest to flower-growers. We must take exception to one statement. In a clever chapter on Ferns the writer says of them: "Spores or seeds are produced on the back of the leaves, and are insignificant and of no beauty whatever." As it is mainly by these that ferns are distinguished from one another, they can hardly be considered "insignificant." Even the common Polypody is handsome in fruit than when sterile, and *Polypodium venosum, aureum* and others are vastly more attractive in fruit, as are the *Goniophlebiums* and many others.

THE FLOWER GARDEN is another quarterly catalogue. This is issued by Beach, Son & Co., Brooklyn, N. Y. We have expressed our good opinion of previous numbers, and that for April is deserving of like commendation—only why don't the editor give credit?

LOUIS LEROY, Angiers, France, shows by his catalogue that this old nursery establishment is up to the times with novelties.

VILMORIN, ANDRIEU & Co., Paris, have a seed-list that is a perfect wonder in the way of completeness. These last two houses, each the most extensive of its kind in France, have as their agents in this country the well-known mercantile firm of Pabst & Esch, No. 11 Murray street, from whom catalogues may be had.

THE BULLETIN OF THE BUSSEY INSTITUTION. Part 2d of this valuable contribution to scientific agriculture is at hand, and like its predecessor is filled with elaborate records of experiments made upon the farm at Jamaica Plain (Boston). Our readers no doubt recollect that the Institution is an adjunct of Harvard University, and Massachusetts is to be congratulated on having in it a place where her young men can be thoroughly taught in the higher branches of agriculture.

RUTGERS' SCIENTIFIC SCHOOL, which is the New Jersey State Agricultural College, sends an interesting report for 1873.

CORRESPONDENCE BOTANIQUE is an attempt to give a list of the botanic gardens of the world, in which there is great room for improvement, as far as the United States are concerned. Compiled by E. Morren, and published at Liege, Belgium.

FOREST TREES IN MINN., a pamphlet of twenty pages, by L. B. Hodges, of "practical suggestions," etc. Published by the St. Paul and Pacific Railroad Company, St. Paul, Minn.

WESTERN NEW YORK HORTICULTURAL SOCIETY held its nineteenth annual meeting at Rochester, in January last, and its proceedings come in a valuable pamphlet of fifty-six pages. P. Barry is president, which probably accounts for this promptness.

NEW JERSEY STATE BOARD OF AGRICULTURE.—Its first annual report gives its organization, an account of the work done, a geological map of the state, and other useful matter. Prof. Geo. H. Cook, New Brunswick, is secretary.

THE FLORA OF COLORADO, by Thos. C. Porter and J. M. Coulter, is one of the reports relating to Prof. Hayden's survey, and of great value to all interested in the plants of the far West. Received from the secretary of the interior.

COMMERCIAL FERTILIZERS AT HOME AND ABROAD is the title of a lecture by Prof. W. O. Atwater, Wesleyan University, Middletown, Ct., before the Connecticut State Board of Agriculture, and is of importance to all who deal in or use artificial manures.

THE EDUCATIONAL CLAIMS OF BOTANY is an essay by Miss Eliza Youmans, which should be read by every school officer in the country.

Western Fruit Prospects.

Reports from the fruit-growing regions of Illinois, Michigan, and Ohio, received at the Western office of Orange Judd Company up to May 1st, are generally favorable, and in some cases unusually promising. In Central and Southern Illinois the anxiety is in regard to peaches. The severe winter of 1873-'73 dismantled many fine orchards—so many, that last season the region about Centralia was scarcely counted as a peach-growing district. Entire orchards were cut down, and the fruit-growers turned their backs on peaches. But the young trees escaped with comparatively little injury, and now wherever there are young orchards there is promise of an abundant crop of peaches. In the Alton district the prospect is still better. The trees will bear a full crop, but as there are not as many trees as of old, the crop in the aggregate will not measure with the full crops of former years. As the crop will be mainly from young trees, it

is argued that the fruit will be of superior quality. In the extreme southern part of the State the frosts this season have done much injury to the peach huds. In the Illinois fruit district apples and pears promise well. In the northern district pears do not succeed well. While in northern Ohio the men who have lost peach orchards are turning to pears as a safe and profitable investment, in northern Illinois men will hardly consider the question at all. It is certain that in the vicinity of Toledo we find some of the finest pear orchards in the West, but profits come after a long experience in the testing of varieties. Whether any varieties would succeed well in the vicinity of Chicago seems to be an open question. In the great Michigan fruit district there is promise of a rare crop of peaches and other fruits. While the spring has been unfavorable in a general way, it has not been unfavorable to the fruit interest. In northern Ohio the peach trees of bearing age will give not more than a fourth of the old crop in favorable years. Grape-vines will give probably a fair crop, which means a better crop than last year. Apples, pears, cherries, and all small fruits except strawberries promise well.

North-Western Dairymen's Association.—The eighth annual report of the North-western Dairymen's Association contains the addresses delivered and discussions which occurred at the annual meeting held at Woodstock, Ill., in February last. We have before alluded to the interesting character of these proceedings, and have now only to recommend those dairymen who wish to read them at their leisure to procure a copy from the secretary of the association, G. E. Morrow, of Madison, Wis., or the president, Stephen Favill, of Lake Mills, Wis.

Bees Notes.—Advice to Beginners.

BY M. QUINBY.

Many ladies have written me that they are almost persuaded to become bee-keepers, and have been encouraged by what has appeared in the *Agriculturist*. With a little further direction, they see no reason why they can not turn their labor to more advantage, pecuniarily, than in fancy work. I would say once more to those with sufficient ambition and perseverance, learn how, and I confidently predict success. Fear of stings, that has kept so many from the undertaking, needs scarcely be an objection, now that smoke (that has long been used to neutralize the poison of their stings and quiet their anger) has lately been applied so effectually that there is little risk. The most convenient way of applying it was to set a stick of decayed wood on fire without a blaze, hold it near the bees, and blow the smoke on them. This brought the face often disagreeably near, and sometimes there was danger of fire from sparks blown off. We now place the burning stick in a tin tube, and with a small bellows connected with the tube, held and worked with one hand, it is safe, convenient, and effectual. Mrs. A. has more than one hive of bees—they are in movable combs, of course. She says: "One has apparently become crowded with bees; another seems to work well, but there are not many bees. They have honey enough. What is the matter?" It may be they have no queen. Yet Mrs. A. says "they never bring in honey-bread if they have lost her. I have seen somewhere that they work just as well without a queen as with one." I would advise the lady in question to look inside the best one first. She will need a sharp-pointed, heavy jack-knife, or, what would be still better, a carpenter's scratch-awl, made flat at the point, to use as a lever to pry the frames apart without much of a jar. Let it be in the middle of the day, while it is warm and the bees are busy. We will suppose the operator is timid, and in that case it will be judicious to put on a veil, for an unlucky movement might make the bees angry; yet it must be admitted one can not work as satisfactorily with a veil on. Then go to the full hive—the top is loose, not nailed—slip the knife under, and pry it up from the top, raising it very moderately an inch or two. If no angry buzzing is heard, take it off quietly. Should a jar or too sudden exposure to light get up an excitement, when the top is first raised an inch, the buzz will be heard. Blow in some smoke, which will drive the bees down among the combs. After the top is off, once in a great while a few bees may come to the top of the frames and manifest anger, when a little smoke should at once be directly applied at the exact point wanted. If suspended frames, pry them apart, giving room to take out one from the middle without touching others. Be careful not to crush any bees. Pry all the frames loose, and lift one out. If the other kind of frames, begin on the outside, and move sidewise first, then hack half an inch, and unhook and lift it out. Sometimes, even at this season, they are nearly out of honey. If they have any sealed up, there

is not much danger of starving. Look at all the combs as you take them out, and if there is no sealed honey, feed a little. If there is enough, see how much sealed brood they have—don't mistake that for sealed honey; the brood is generally near the center of the hive, they spread it from there each way. Estimate the number of square inches sealed in each comb. Fifty square inches in each, of six or seven combs, will make a tolerable swarm when it hatches. Find the queen while you are looking, catch her, and cut off one wing—she will never leave with a swarm for the woods afterwards. If they are making preparations for swarming, queen cells may be seen, most of them containing larvae, and a swarm may be expected to issue the next fair day after the first cell is sealed up. After seeing how the inside of a good, thrifty stock appears, it is well to examine a weak one, and find what is wrong there. Proceed to open it in the same way. Most of the bees will be found near the center. Examine the combs there for the queen, brood, eggs, or foul brood. There are many things to prevent an increase of bees. The eggs of a bee must be kept warm, like those of a fowl, to hatch well. Bees enough to feed and rear them are necessary. The warmth in a weak hive is generally deficient. If no disease, see if they have any brood sealed. If that is found, the queen is probably all right, without bees enough to keep the eggs warm. If no brood is in any stage of development, and no queen can be found, it can be put down as queenless, but not to be discarded. There are combs worth several dollars and some bees, and may be something can be done to save them. Take from the best hive a comb with brood ready to hatch, as nearly as can be judged, as such require no nursing. An empty comb—at least one without brood—can be taken from the light hive and put in the place of the one taken containing the brood. See where the bees are thickest in the light hive. Part the combs there, and put in the one containing brood. Close the hive all but one small entrance, to make it as warm as possible, and the maturing brood will strengthen the colony materially. If they hatch well, another comb can be given in a week or so, and still another until strong enough. Occasionally the queen is lost while there is brood to rear one, and they do it. In such a case, the remains of the queen cells will be seen. A young queen, before laying, is not so easily found as the old one; she is nearer the size of workers, and very active. To make it more certain that there is no queen, look again in three or four days after the first examination. They will have started some queen cells over some of the brood that was given them, if there is none. If no cells are started, it would indicate that there is a queen and she is either too young to lay or barren. If no eggs in ten days it shows the latter; when she must be found and destroyed. If not likely to have a laying queen of their own, give them one; but it will not do to leave her to make the colony strong without giving brood. If any hive has swarmed, queen cells may be had in place of the queen. The young bees that have hatched from the first comb of brood will be more likely to succeed in raising a queen than the old bees that were in the hive. By continuing to change combs with the strong, the weak ones can be made as good as the best. One queen will generally lay eggs enough for two hives, if change of combs is properly made. After there are bees enough to nurse a larger number, more of the brood that is not sealed up may be given them. Occasionally a hive is only weak from want of brood, which, if introduced in this way, will soon make a worthless hive a profitable one. The condition of every hive should be understood. Learn to distinguish between a good and a poor one. This can be done now more conveniently than ever before; and I have consequently more hopes in the success of ladies. They will take time to study the subject more deliberately, think what they want to do, and why, and help discover many things yet in the dark.

Increase of stocks will be desirable. But let strong colonies be the first idea. When all are so, and the yield of honey is good, you can choose between surplus honey and increase. An excess of both is not often realized. I advise putting boxes on full hives, and allowing the bees to fill them if they will. Keep watch for the queen cells, and if they are determined to swarm, make them do it artificially. Directions for doing it have already been given. If the honey is extracted, not more than one in fifty will try to swarm. In most sections, but little surplus is collected after the first of August. If there has been no increase, and there are bees enough, it will do to divide at this time, if care is taken to feed according to their needs. When there is no buckwheat or late fall flowers, a colony may be wintered by feeding. It would be well to have a laying queen ready to introduce when divided at this time. Twenty-five pounds of sugar will take a swarm through the winter, when they have no honey.

Learn how to make all stocks strong, and to know when they are strong.

Very many allow their bees to build their combs

crooked on the frames, through neglect, and can not examine them in consequence, and then inquire what shall be done. I will give a specimen:

CHESTER CO., PA.

I have two colonies of bees in Langstroth's movable comb hive. I would like to take out the frames to examine them, but the bees have run the combs zigzag so that I can not get them out without much cutting. I want to artificially swarm them this summer. How shall I proceed?

HOWARD D. BUSH.

I have many such. The proceedings should be in accordance with the shape of the combs. They are much more crooked sometimes than others. When very crooked transfer as from a box hive. Quite often on one side, on one or more frames the combs are straight. Sometimes a part of the combs will run straight part way on the frame. First, see to how many frames one comb is attached. If any are disconnected with others take them out first. These can generally be seen from the top. When the colony is strong and the weather cool enough for the *propolis* to snap and jar the bees enough to wake them up, it will be necessary to use smoke. The top of course is off. The combs that cross the frames are welded fast to the sides of the hive. Now you want a long thin knife—a carving knife will do. Drive the bees away with the smoke from the place you wish to loosen. Cut every comb from the sides of the hive. With a sharp-pointed instrument loosen the frames where they rest on the rabbeting, but do not move the frame enough to break the comb. Put on the top or honey board, and turn the hive bottom upwards. If the frames, where they rest on the rabbeting have been properly loosened and the combs all cut loose from the sides, the hive can be lifted off, leaving the combs standing. Don't be alarmed and think the stock ruined, and feel afraid of being stung. Nothing of the kind will occur if you have used smoke judiciously. Keep cool and think what is to be done. Smoke and drive the bees away from where you want to see the comb. If there is any comb straight part way on the frame, leave it fast. Cut off all that crooks from a straight line; keep the pieces as large as possible. As you cut them out lean them against something pretty straight up for a time. When the bees gather in little clusters they may be brushed or shaken into an empty box for the time being. As soon as a frame is loose and separated you can proceed to fill it with combs; hold it with small sticks fastened just as directed last year for transferring. Cut off drone comb. Set up the hive and put into the frame with the combs straight. They will soon be fastened, when the sticks may be removed. If necessary to use drone combs to fill the hive, let them occupy the outside frames. If the hive is such as I recommended last June, which could be enlarged or diminished at pleasure, there would be no need of using drone comb to fill it. If bees have to build comb to fill the hive at this season, it is quite sure to be drone cells. In filling the frames, if there are spaces an inch or two square left there will be no great loss, and bees fill them with the large cells. It is possible that rearing a few drones in combs of this size, may gratify an instinct and stimulate to some benefit.

Ogden Farm Papers.—No. 52.

Six years ago there was formed an association of breeders under the name of the "American Jersey Cattle Club." The purpose was to establish a "Herd Book" and to encourage the breeding of pure animals. The association now includes more than one hundred of the principal breeders of this stock, most of the northern and some of the southern states being represented in it. Great care is taken to admit to membership only the most trustworthy men, and no pedigrees about which there is the least room for doubt, are accepted without the indorsement of a member.

Three volumes of the "Herd Book" have been completed, and nearly five thousand pedigrees are recorded. This part of the work goes regularly on, and the book is now self-supporting, so that the fund derived from membership fees can be appropriated to other purposes. At the recent annual meeting \$600 were appropriated for the procurement of an essay on Jersey cattle, which shall be adapted to making their advantages for American uses generally known. Three prizes are offered: 1st, \$250; 2d, \$150; 3d, \$100; and the amount

remaining is to pay for the cost of publication and distribution. It was also decided to hold a show of Jersey stock in connection with the Centennial Exhibition in Philadelphia in 1876.

My attention is called by a correspondent to the "Basket" item in the *Agriculturist* for May, entitled "Jersey and Alderney," which he thinks calculated to mislead. He asks whether there are any Alderneys in this country, and whether they can be entered in the Jersey "Herd Book." There are four principal islands in the Channel group—Jersey, Guernsey, Alderney, and Sark. Jersey, the largest, is about the size of Staten Island, in New York harbor; Guernsey is less than half the size of Jersey; Alderney is only about one sixth the size of Jersey (about 2,500 acres); and Sark is (in arable land) considerably smaller than Alderney. These are usually called, not the Alderney Islands, but the Channel Islands. They have two distinct breeds of cattle—Jersey and Guernsey. Sark has a mixture of the two, and Alderney is stocked with animals originally from Jersey, but with the admixture of some Guernsey blood. It is not usually considered a distinct breed, and is not accepted as a pure race in the other islands. Alderney cows are apparently degenerated Jerseys, or rather Jerseys which have not been improved as they have been in the larger island. I know of but one Alderney cow in America ("Lottie," belonging to Mr. Wm. F. Botts, of Philadelphia), and she has every appearance of a Jersey, though she has been refused admission in the "Herd Register" of the American Jersey Cattle Club. The name "Alderney" was given to Channel Islands cattle because the early importations into England were from that island, where there are many English residents, and it has probably been retained by mere force of habit. Its retention in this country was perhaps due in part to the confusion that might follow between Jersey and New Jersey. What we call Alderneys are almost exclusively Jerseys. There are a few Guernsey cattle in the United States, but not enough to constitute a prominent class. They are large, rich milkers, and good farmer's cows, but they lack the characteristic beauty of the Jerseys, and are on this account less attractive, even to ordinary farmers, who like handsome animals as well as any other class in the community.

During the past month I have been "neighboring" among some farmer friends in Massachusetts, and have had some light thrown upon the question as to whether farming is a good business in New England.

Mr. Edward Burnett, of Southborough, is a young man who, during his college vacations, and even as a boy before he entered college, indulged his agricultural tastes by hiring himself out as a farm hand, and learning the business from the bottom. Mr. Bowditch, of Framingham, tells me that he used to pay him during haying and harvest \$40 per month and board, and considered him the best hand he ever had. During this occasional apprenticeship, he boarded with the farm hands, and was in all respects on the same footing with them, so that he became a thorough-going, practical farmer. When he left college, he took the management of his father's farm, which was well improved, and when he married he bought the farm (200 acres) on mortgage, and went at it like a man to work his way out. From present indications he will

not be very long in demonstrating his success. Of course he has material advantages in having fallen heir to many improvements, made without especial reference to their cost, and which a farmer beginning at the bottom of the ladder would not have—some which, although valuable, are hardly worth what they would cost to make anew. On the other hand, he has as good a farm to lose money on as could well be found, if he would only develop its resources in this respect; and nine men out of ten, not used to farming, taking it with a good capital, would swamp their fortunes in very few years; for a good farm, with the appliances for fancy farming, responds very promptly to the influence of neglect and bad management. It will be fertile in disaster or in success exactly according to the skill with which it is managed. Mr. Burnett may be safely depended upon to steer his craft in the right direction, and to demonstrate the possibilities of agriculture in New England, which seems to me to offer a better opening to an enterprising man than does that of any other section of the country.

All that New England seems to lack is a fertile soil—its fertility has waned, and the brood which fed upon it in its "virgin" days has gone West, and further West, leaving in their whole track a worn-out soil and a prosperous and well-peopled land. They have earned to the country more than they have cost it, and I am not disposed to give them anything but praise. But it remains for us, who benefit by their pioneering, to restore the productiveness of their fields, and to follow their simpler destructive farming with a system that has been made possible only by the general prosperity they have initiated. The farm that we have to cultivate is less rich than they found it, but it is in the midst of a wealthy and thriving population, and this is an advantage that can hardly be overrated. If we work as though our farm were in Western Iowa, we shall probably fail—and deserve to fail—for our poor land can not compete with the Western farm, under the same system. But if we realize the fact that we have, within easy reach, a market that is eager for the best and freshest products of a sort that will not bear long transportation, and that we are surrounded with towns and villages from which we can get an abundant supply of manure, we shall see that our circumstances are worth more to us than our acres, and shall introduce into our operations an element of success that is impossible to those who are more remote.

The most hopeful thing about Mr. Burnett's case is that he has realized this condition, and works to meet it. His cows are pure Jerseys (and good ones) and he has a ready market in Boston (by contract with a large hotel) for all his butter at 75 cents per pound. Then again, he makes a large item of the swine, which feed on his skimmed milk (and on corn-meal), and of similarly fed pork, which he contracts to take from butter-making farmers in his neighborhood. He does not go into Faneuil market and sell for the going price for the best quality, but advertises that he makes a specialty of family pork, fed on milk and corn alone, and put up with the greatest care; that he will deliver at private houses in Boston, free of cost, lard, bacon, jowls, shoulders, hams, and sausage-meat at 20 cents per pound. In this way he gets 10 cents per pound for the cost of raising and dressing his pork, which pays, and

another 10 cents per pound for preparing for market in the best manner, and this pays enormously. Another item of his business is the sale of family cows. These he buys from farmers far and near, on his own reliable judgment, at fair farm prices, and is able to sell at a good advance to persons who have confidence in him and in his knowledge of cattle, but who have neither the time nor the experience to select for themselves.

His whole system is based on advertising, reputation, and the demand for strictly first-class supplies for families who can afford to pay extra prices, and who know the value of extra quality; and this is the best basis he could possibly have—the only one which takes his circumstances as they actually exist, and makes the most of them. If there is any better definition of good farming than this one of *making the most of all existing conditions*, I have not found it out.

I imagine the comment being made, as it always is made, that if everybody did as Mr. Burnett does, there would be no extra quality and no extra prices. Exactly! But everybody won't. It is only the very, very few who will ever try to do the best that can be done, and such examples as the one now given will always be rare. It is given not as praise to a friend, but as an incentive to the few enterprising men who are well located, here and there, in the Eastern states, and who really "mean business" when they undertake an improved style of farming—men who are destined to be valuable examples of success in farming, and to revolutionize the agriculture of their neighborhoods, and who are to be followed by others who will be as far in advance of them as they are of the average standard of to-day.

It is not safe to advise any young man to adopt farming as the business of his life; but to those who have decided on this, it is surely safe to advise an emulation of the example of Edward Burnett, beginning, as he did, with the hard work of the farm, hand in hand with the other hired men, and learning the details of all kinds of work by downright hard work, until, like him, they can beat many a born farmer in the harvest-field, and many a born dairy-woman in the butter-room.

I hope I shall be forgiven if I temper my commendation with a little criticism, which I do publicly (as I have to himself in private), and warn eager youngsters against the error of being "boss and all hands." It is too much to ask of any merely human mind and body to work like a slave from morning until night in hard field work, and at the same time to manage the business and carry on the correspondence of such an establishment as I have described. It is very important that the head of such a farm should be able to do any sort of work in-doors or out of doors, and to know how to get it done by others; but the large capital invested, and the important outside interests on which success so largely depends, are not fairly treated when they get only the guidance of a work-wearied brain. The one part of the work which can not be hired done is the part to which the owner's first care and best and freshest efforts should be given. If you are your own foreman, you must be always to the fore, and exhaust your capacity in manual labor. It is better to have a good hired leader, and put a shoulder (physical or mental) to the wheel whenever and wherever it is most needed at the moment. Labor is one agent you have to employ, but business man-

agement is an equally important one; and as the captain of a steamer is worth more in the pilot-house than in the stoke-hole, so is the manager of a large farm worth more in the general direction of his operations than at the end of a hoe-handle.

Another example of a young Harvard man turned farmer, is Mr. E. F. Bowditch, of Framingham, who has taken 400 to 500 acres of worn-out farms, and built up a capital establishment, to which he devotes his whole time, and on which he is reaping a permanent and satisfactory success. His case is less instructive than Mr. Burnett's, because he started with a capital that few young men turning farmers can command; but it is, at the same time, an example well worthy of the study of all who go to the business hoping to find it at least an inexpensive pastime, and who too often do find it a most wasteful extravagance. Like Mr. Burnett, he is a breeder of Jersey cattle, of which he has an unusually fine herd, descended from his own importations, and he sells his butter at a high price in Boston. It was largely a desire to see his Jerseys which led me to visit him, and I found them well worth the trip. I am sure I shall be doing a favor to my readers, to whom this may come in time, by calling their attention to the fact that he advertises an auction sale of twenty or thirty head—his surplus, but including some of the best of his herd—to take place in Boston on the fourth of June. This will be a good opportunity to purchase, and an equally good one to study the characteristics of some excellent specimens of the breed.

A correspondent in Illinois writes: "I wish you would call attention to my way of preventing cows from kicking, though it is by no means my invention. I know that not one farmer in a hundred knows how to do it. I use it in breaking my heifers to milk, with great success. Take a strong strap and buckle it tight around the cow, in front of the bag and back of the hip-bones. If drawn tight, the cow can not kick, and she will soon cease trying." This seems like an efficient remedy, and it is so simple and safe that it is well worth being brought to the attention of those who have restless cows and nervous or sore-teated heifers to train.

The long continuance of cold weather this spring made it necessary for us to buy a small stock of hay, but our own supply, which was of excellent quality, lasted until April 25th, and we are fully content with the result thus far. One help we had from outside, it is true. We last spring hired two acres of clover which had been sown in 1872 with barley. It was intended for soiling, but we did not need to use the whole of it in this way, and made a part of it into hay. We weighed all that was brought to the farm. Allowing six tons of green clover to make one ton of hay, the crop of the two acres was equal to *eleven and one half tons of clover hay*. This heavy crop was due to the good management (good management in this case meaning heavy manuring) of the owner, who is one of our best farmers, with a firm

conviction that what is worth doing at all is worth doing well. He has another firm conviction, which is that good land is worth a good rent, and he charged me \$200 for the rent of that field for one season.

Swivel Plows.

The advantages of the swivel plow are not so well appreciated as they should be. A few years ago, desiring to test their value upon level ground, we did the whole of our spring and fall plowing with them. We used one of them which was designed only for hill-side plowing, and by no means so well calculated for level work as some of the newer and improved plows, both for sod and stubble, and found it a great saving of time and labor. By returning upon the same furrow we went up there was no waste in going around the headlands, and the harrow could follow close up to the plow. Thus, in corn planting in the spring or in sowing wheat or other crops, every foot of plowed ground at the close of the week could be finished and sown or planted, and on Saturdays the week's work evenly and neatly done up. Besides, the seed could always be put into the ground while the soil was mellow and moist, an advantage in some seasons of great importance. The annexed engraving shows one of these plows greatly improved and furnished with a coulter for plowing sod. It will be seen

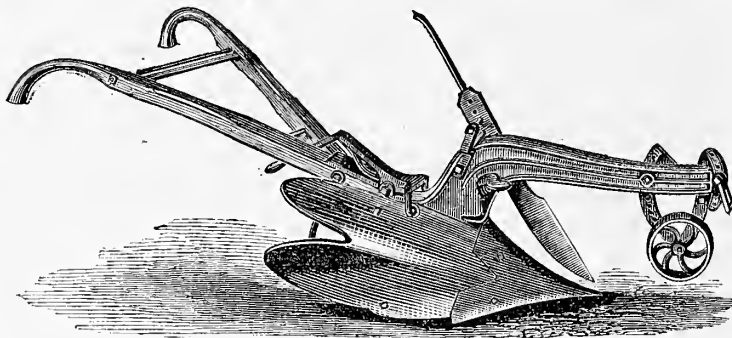

SWIVEL FLOW.

that the character of the mold board is such as to insure easy draft, and as in using these plows each horse alternately walks in the furrow the labor of the team is greatly lightened. The efforts of plow makers have been industriously turned of late to the improvement of these plows with great success, and it needs only that the attention of farmers should be drawn to them to profitably extend their use.

The Use of Steam on the Farm.

As compared with other industries the business of farming is not carried on economically. The cost of producing what there is to sell is too high, and the profits are reduced accordingly. Steam power is made useful in nearly every industry but farming, and in that horse power is the sole dependence. At some future time it is probable that much of our field work will be done by steam. At the present time a large share of the in-door work of the farmer may be. A great portion of his business and labor is in feeding stock and preparing their feed. It has been frequently shown that when feed is cut and steamed it is fed with the greatest economy. The great bugbear connected with it is the labor needed to cut and steam the feed. It is said that it will not pay to steam feed for less than forty or fifty head of

stock. We are satisfied from our own experience that it will pay with only ten head. Where there are less than ten head of stock upon a farm the use of steam will in most cases

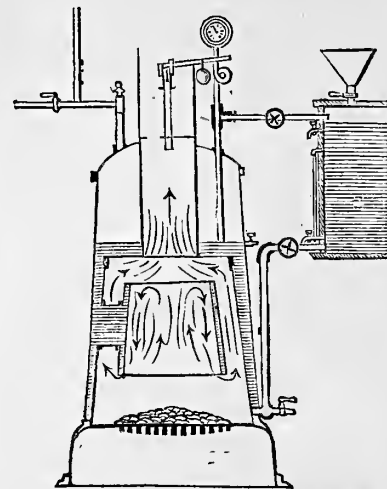

Fig. 1.—SECTIONAL VIEW OF BOILER.

make it profitable and practicable to increase the number up to ten head without extra cost of food or labor in preparing it at all in proportion to the increase. As to the cost of the machinery, it is well worth considering whether if a five-horse power boiler and engine that could do all the inside work of the farm, cutting feed and steaming it, thrashing grain, hoisting and unloading hay or grain, sawing wood, and any other work needed, could be procured for \$580, all complete and ready to run, and could be operated with safety from fire or explosion, it would not be a great economy; the cost of fuel, too, being less than fifty cents a day for such an engine, and that only while it is working. The first cost of five horses, harness, etc., would be considerably more than the cost of such an engine and boiler, not to speak of the cost of maintenance. The boiler and engine we here specially refer to are made expressly for farm use, by Whitman & Burrell, of Little Falls, N. Y., and are known as the Anderson steam boiler and the Kipp engine. A sectional view of the boiler is shown at figure 1, and the boiler, water-tank, and engine at figure 2. The boiler is double, so that water completely surrounds the fire space. The large heating surface requires but little fuel, and the water-tank is so arranged that while the supply of water is kept up there is perfect safety. The engine is compact, and of very strong and solid construction, and is made as small as two-horse power. An engine of three-horse power needs no more fuel than an ordinary stove of common size. It is impossible to doubt that there are thousands of farms

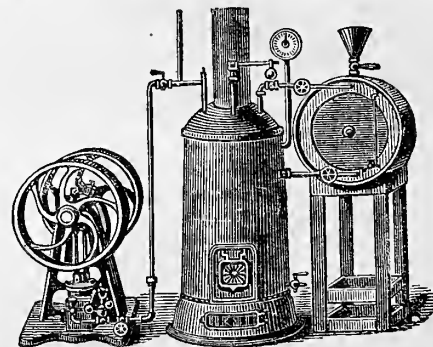

Fig. 2.—ENGINE, BOILER, AND WATER-TANK.

upon which steam power so cheaply procured would be a great advantage and its purchase an economical investment.

Some Wild Ducks.

BY J. H. BEATTY.

Upon this page are illustrated four drakes of very beautiful and somewhat rare native ducks. They are generally known to the sportsman, and all to the ornithologist, yet they are almost strangers to the general public. There are forty-one distinct species of ducks that inhabit North

striped with two longitudinal black bars, which meet near the base of the bill and spread as they approach the neck, making a V-shaped figure. The tail is slightly rounded, the quills pointed and brownish black; back brownish black, with two small patches of white on the rump; wings brownish black; coverts white; secondaries curved, hanging pendant over primaries; back, neck, and shoulders

the crest lies flat. The systematic name of the Hooded Merganser is *Lophodytes cucullatus*. The male has its head and neck black, with a half crescent shaped patch of white extending along the top and back of the crest; the upper parts are black; secondaries and scapulars striped longitudinally with white; base of neck banded with a crescent of white; sides brownish, finely barred with brownish black; tail

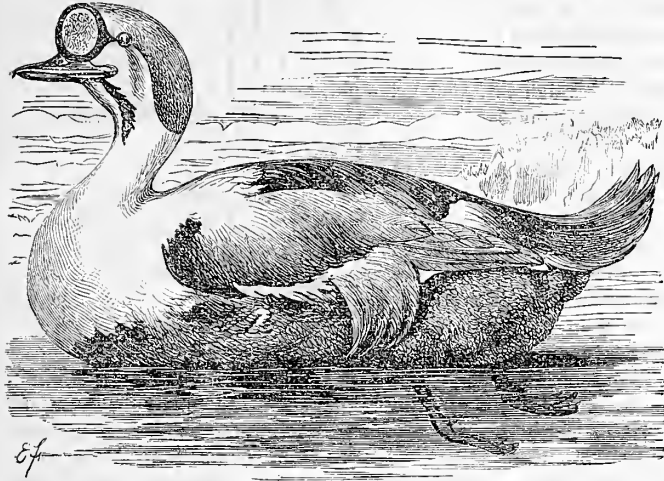

Fig. 1.—KING EIDER DUCK.

America, including the Teals and Mergansers, and twenty-six of these are common to our Eastern waters. One of the largest, rarest, and most beautiful of ducks is

THE KING EIDER DUCK, *Somateria spectabilis*, or King Duck. It is the most boreal of its family, and during the severest winters it is seldom observed south of the Bay of Fundy. Its migrations are not so extensive as those of other ducks, and it ranges on our Eastern coast from Machias, Maine, to the Arctic Ocean. The King Ducks are erroneously known to the cod and herring fishermen as "mongrel sea ducks," and are by them supposed to be hybrids between the common Eider Duck and some other species. They breed in Labrador in considerable numbers, but the greater body of them nest further north. The specimen from

white; top and hind head pale dove color; checks sage green; forehead furnished with a fleshy knob or perview, membranous protuberance, partially divided by a black band of feathers which extends from the nostrils to the top of the head; bill rather small, toothed, and furnished with a strong nail at the extremity of the upper mandible.

THE HOODED MERGANSER is widely distributed throughout the United States, and may be called a fresh-water duck. I have taken several females near the Fire Islands, N. Y., but they were migrating, and evidently were more in search of a resting-place than of feeding grounds. This duck is often found in company with the young of the year of the Buffel Head in the inland lakes and rivers during the autumn. It feeds on fish,

long and rounded and brownish black; bill long, narrow, convex above and underneath, and deeply toothed; eyes light yellow. The dimensions of the specimen from which the drawing (fig. 2) was taken are, extent 27 inches, length 18.50 inches. While the Hooded Merganser is by some authors placed in a separate genus, *Lophodytes*, others include it in the genus *Mergus* with the

RED-BREADED MERGANSER, *Mergus serrator*, which is also called the Fish Duck. It is not a rare species in this country, and is found also in Europe. Like our only other species, *M. Americanus*, the Shelldrake, this has a red bill with the upper mandible furnished with sharp recurved teeth; the male has a conspicuous crest; the head and upper part of the neck dark green, the under parts reddish white; the

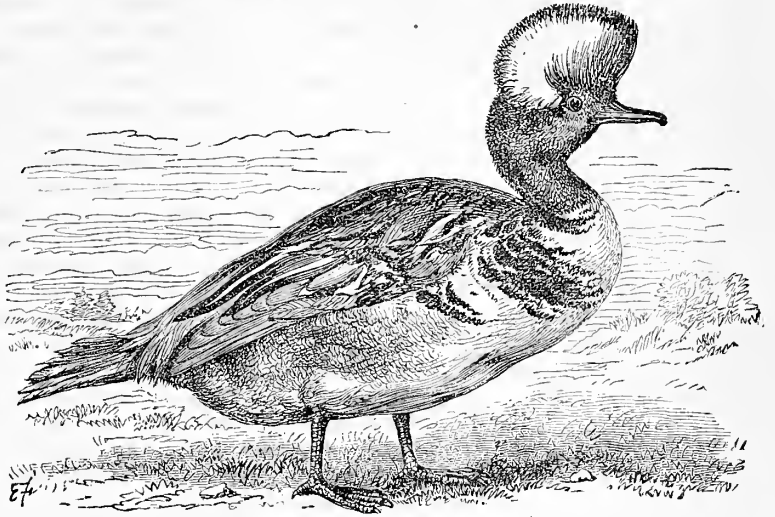
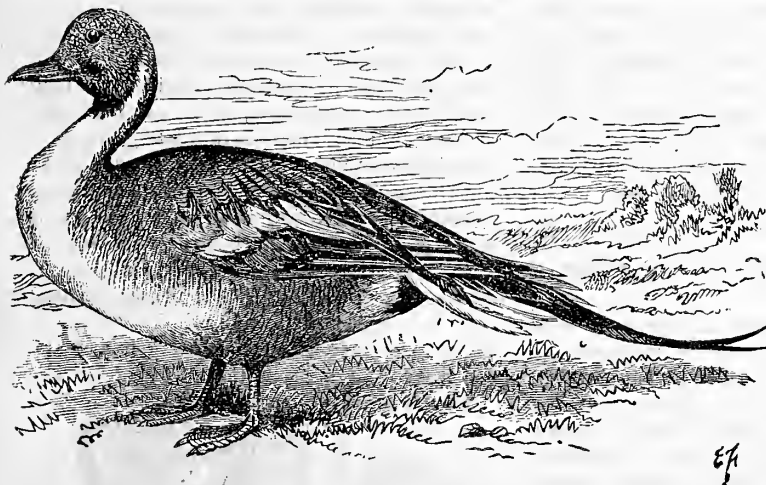

Fig. 2.—HOODED MERGANSER.



PINTAIL OR SPRINGTAIL DUCK.

which the illustration (fig. 1) was taken was shot in Labrador in Nov., 1871. The eggs of this duck are small in proportion to the size of the bird, are of a uniform pale green color, and from three to seven of them are deposited in the nest, which is made of moss and lined with down plucked from the breast of the female. The King Duck is black from the breast to the tail; breast cream colored; throat whitish,

and is an expert at diving. When wounded, it often gives a severe chase to the hunter, who when it appears on the surface of the water after diving bangs away at it in vain. It has a large, full, hair-like crest or hood, which can be erected or depressed at will. When the bird is swimming on the water the crest is raised, giving it a very showy appearance, but when it is flying or swimming under the water

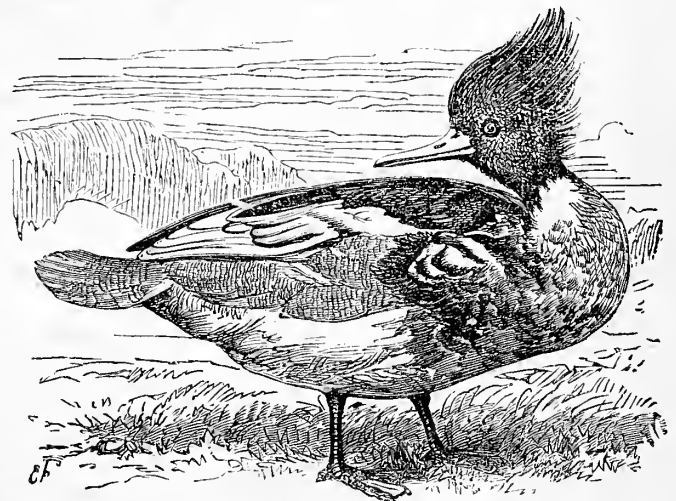

RED-BREADED MERGANSER.

portion just above the breast reddish brown, streaked with black. The sides are conspicuously barred with transverse black lines, and the white of the wing is marked by two black bars. The only remaining species that there is at present room for, is a bird well known to sportsmen as the

PINTAIL OR SPRINGTAIL, *Dasila acuta*, more nearly related to the proper ducks than any of

the other species here figured, and distinguished from them by its much narrower bill and its remarkably pointed tail. Its bill is black above and below, and on the side a deep blue; the head and upper part of neck deep brown, with a green and purple gloss behind; the lower side of the neck, breast, and body white; the back and sides finely lined with black and white; there are sixteen tail feathers. This duck is common all over the country, and in the fall of the year is very common in the New York markets, which are principally supplied from the West, large numbers are sent from that part of the country in the fall, and there is an irregular supply all through the early part of winter. The marketmen call it also Winter Duck. It is one of the prized varieties for the table. We have engravings of other species which must wait until another time.

Walks and Talks on the Farm.—No. 126.

"W. W.," of Fairfax Co., Va., who is raising early lambs for Washington market, asks if it is true, as he has heard, that Cotswolds are too slow in maturing for this purpose. It depends on the kind of Cotswolds—or, more correctly, on how they have been bred. If the object of the breeder for several generations back has been to obtain the largest sheep, if the breeder has aimed at size and that only, then doubtless such sheep will not mature early. I am sorry to say that some breeders of Cotswolds have done this very thing.

The last time I was in New York, Col. Weld, who has always taken much interest in the so-called Mapleshade flock of Cotswolds, remarked: "They tell me you are reducing their size."—"I do not think it is true," I replied, "but it depends on what you mean by reducing their size. If you mean that I am not aiming to breed sheep that at three and four years old will weigh 400 lbs., it is true. I do not want such sheep. But if you mean that I am reducing the amount of wool and mutton in my lambs and yearlings then it is not true. I am aiming to breed sheep that are intrinsically good—good for the purposes for which they are kept, and not good merely to attract attention in the show-yard."

"Thee writes," continues my Virginia correspondent, "in reply to 'R. P. W.,' of Nebraska, in No. 123 of Walks and Talks, that thee keeps about a half dozen Merino ewes to raise lambs for thy own use; are not Cotswolds as good, or why does thee keep Merinos for that purpose?"—For this reason: The Cotswold ewes cost from \$75 to \$100 each, and the Merino ewes I bought for \$2.50 each. I have never killed a pure-bred Cotswold lamb, but imagine it would not be bad eating. The grades are good enough for a farmer, and much better than any lamb I can buy in market. With a little mint sauce and a dish of green peas picked fresh from the garden, a grade Cotswold-Merino lamb that will dress 40 or 50 lbs. is decidedly good eating after you have earned your dinner in the hay-field.—"This is all true enough," says the Deacon, "but 'W. W.' probably means to ask if you would not get better lambs from common long-wooled sheep crossed with a Cotswold ram than you would from common Merino ewes?"—You might get better lambs and you might not. It depends on the feeding. The Squire got a lot of long-wooled sheep in Canada, and bought a pure Cotswold ram from me. His lambs, now a year old, will not average over 60 lbs. live-weight.—

"That is so," says the Deacon, "but it does not say much for your pet theory about using thorough-bred male animals to improve our common stock."—"I will not argue that matter with you, Deacon," I replied, "and I do not want to make the Squire angry by telling how he has fed his sheep. I have scales in the barn, and if you will go with me we will weigh some of our grade ewe lambs, now (April 15th) from eleven to twelve months old."—"All right," said the Deacon, and we got the shepherd and drove the sheep into the barn.

"Now then, Fred," I said, "the Deacon wants to see if your grade lambs will weigh as much as the Squire's. Pick out a good one." He did so and put her on the scales. She weighed 118 lbs. "Now catch another;" 119 lbs. The next weighed 101 lbs. "Now catch some of your thorough-bred Cotswold ewe lambs." The weights were 123, 122, 125, 135, 129, 137, 125, 125, 109, 104, and 101 lbs. The last one had a magnificent fleece of fine lustrous wool, from 12 to 14 inches long, and though the lightest lamb in the flock is certainly not the poorest. "But tell me," said the Deacon, "did you not once say in the *Agriculturist* that the Cotswolds were the largest breed of sheep in the world, and that if a man had a small one it must be a grade?"—"No. I never said anything of the kind. I should be much more likely to say if you have a sheep of great size he must be a grade or a cross-bred."

"Won't you weigh the ram lambs?" asked the shepherd, "it will not take long." He evidently wanted the Deacon to see them weighed. The first one weighed 145 lbs.; then 142 lbs. "How old is this one?" asked the Deacon.—"He was dropped May 3d, 1873, and is about 11½ months old."—"He is a good one," says the Deacon.—"We have some bigger ones," remarks the shepherd, "and I was allowed to feed them only a little grain and no hay until the 1st of March."—"Bring on your next," I said; "the sheep never did better, though they have been wintered on pea-oat-straw, bran, and mangels. I am not ashamed of them."—"Here is a good one," said the Deacon.—"Yes, splendid fleece, but his long wool makes him look larger than he is."—He weighed 157 lbs.—"Now handle them and pick out the heaviest. How much?"—"179 lbs."—"Try another."—187 lbs.—"That will do; if you get a heavier one the Deacon will think it is not thorough-bred."

"How much will such a sheep dress?" asked the Deacon.—"Divide the live weight by 7 and that will give you the dressed weight per quarter. $187 \div 7 = 26\frac{2}{7}$ lbs. per quarter. Now pick out your best yearling ram and that will do."—"He is a noble-looking fellow," remarked the Deacon.—He weighed 253 lbs. I could put another 100 lbs. on to him by next fall, and make him dress 50 lbs. per quarter. But who wants such mutton? Tallow is cheap.

"Don't you want to weigh 'fourteen-pounder'?" asked the shepherd.—I explained to the Deacon what he meant. "We weigh all our lambs as soon as born and keep a record. We had one pure-bred Cotswold ram lamb that weighed when dropped 14 lbs. He is now one month old. How much will he weigh? But never mind guessing. Balance the scales accurately. Keep him still a second. How much?"—"33 lbs."—"Animals eat in proportion to live weight," say the authorities, and a gain of two per cent per week is fully up to the average on a sheep over a year old. That is to say, a sheep weighing 100 lbs. will on good feed gain about two pounds a week. But this lamb

has gained over 20 per cent per week on its average live weight. We then weighed a pair of twin grade lambs that will be a month old to-morrow. They weighed when dropped 10½ and 9½ lbs. They now weigh 27 and 24 lbs. This is a gain of over 22 per cent per week average live weight. In another month these two lambs will together weigh more than their mother. We have another splendid grade ewe lamb that has two crosses of Cotswold blood in her. Weight when dropped 10½ lbs. At a month old, two days ago, she weighed 29 lbs. To-day, 30½ lbs. Her Merino grandmother, at four years old, probably weighed about 70 lbs. So much for good blood—"and good feed" added the Deacon.

"Now weigh the heifer calf and we will stop." This calf was born August 7th, 1873. Small at birth, but pretty. Dam, a native; sire, full blood Shorthorn; weight, now at eight months and eight days old, 420 lbs. Feed during winter, clover hay and raw mangels, with a little skimmed milk when we had it to spare, and a liberal allowance of bran and oats.—"She will go ahead when she gets out to grass," remarked the Deacon.—Yes, and that is one reason why I think, for me, it is better to have calves come in the fall than in the spring. We have been making butter all winter, and by the time the cows begin to slacken in their milk we shall have a good bite of grass to start them on again. In July and August, when the pastures are burnt up and the weather not favorable for butter-making, the cows are dry, and will calve in time to get the benefit of the rich fall feed. In winter you have time to give them the best of care. You can steam the food and not feel that your labor is wasted, as the full flow of milk pays handsomely as you go along. I do not cook the food, but we feed mangels liberally and give two quarts of bran and two quarts of corn-meal per day to each cow. If the cows will not stand such feeding you do not want them—but the butcher will, for they will be fat at a time when beef brings the highest price, say in May or June.

"Now, Deacon, let us go into the house again and look over our letters."

Here is one who writes from Virginia: "I would like to ask your opinion of a plan I have thought of trying with a portion of a field that is to be sown to wheat this fall. Instead of sowing it to oats, as is our custom, and hauling out the manure into a large heap to rot during the summer, I propose to draw out the manure this spring and spread it on the land, and then incorporate it with the soil by plowing and harrowing during the summer to kill the weeds."—"In other words," said the Deacon, "he proposes to summer-fallow instead of sowing oats, and to apply the manure now in the fresh state instead of rotting it and applying it to the fallow in the fall. I think it is a capital plan."—If the manure could be kept in a properly managed heap, so that it would ferment without loss, I think he would get more wheat by spreading the well-rotted manure on the surface of the fallow after the last plowing, and harrow or cultivate it well in. But with carelessly made heaps I have no doubt there is considerable loss of ammonia, and in such a case it would be better to adopt the plan he proposes. One thing is fully proved by Mr. Lawes's experiments on barley and wheat, that when barn-yard manure is plowed into rather heavy land it decomposes so slowly that we do not, for some years at least, get half the benefit from it that the plant-food it contains is capable

of producing. I wrote to Mr. Lawes, telling him that John Johnston and some of our best farmers claimed that they got far better crops by spreading the manure on the surface of the land and letting it lie exposed for several months than they did when it was plowed under. He replied: "I have no doubt that the farmers are quite correct in what they say, as exposure to the air and rain for so many months would set free many of the ingredients of the dung."—"He means," said the Deacon, "that they would be set free and evaporate into the atmosphere, which is precisely what I think."—No, he means that they would be set free and be carried into the soil by rain, and produce a better effect than when plowed under in the fresh state. The soil is so conservative, that when it once gets hold of manure it tries hard to keep it. If you should take a field of clover with a crop on it equal to two tons of hay, plow the crop under on half the field, and mow it on the other half and remove the hay, and then plow it up, and in due time sow the whole field to wheat, what have you done? You have made one half the field 100 lbs. per acre richer in nitrogen than the other half. Now this 100 lbs. of nitrogen is as much as is contained in 70 bushels of wheat and its usual proportion of straw. But does any one suppose that this half of the field will produce, even if we should sow the whole field to wheat for two or three years, 70 bushels of wheat per acre *more* than the other half? And if not, why not? We know that if we could convert this nitrogen into ammonia and nitric acid, and apply it in proper quantity, it will produce a far greater increase of wheat, barley, oats, and grass than when applied in its organized condition. So much we know. But how best to attain this object is yet to be determined.

Mr. Isaac Stickney, of Woodhull, Ill., favors me with samples of wool from his pure Highland sheep and from the half and three-quarter grades. I had supposed that these sheep were best suited to mountain regions, but Mr. S. says he has had them now for six years on his farm in Illinois, and they are very healthy. The soil of the farm, judging from a sample which Mr. Stickney sent me for analysis nineteen years ago, is rich, remarkably fine, and abounding in organic matter—better suited, I should have said at that time, for corn growing than for sheep breeding. Mr. S. has about 900 acres, and he says there is not an acre of waste land on the farm. It is a beautiful rolling prairie. Mr. S. keeps over 100 head of cattle, and has two pure-bred Shorthorn bulls, 100 Highland sheep and grades, 10 horses, and 180 hogs of last year's stock, "mostly," he says, "of the black Berkshire and Poland, so called—a mixed up breed which I never have found a person that could tell what races they were composed of." This so called Poland-China breed originated in Butler and Warren Counties, Ohio. The last cross, Mr. Milliken tells us, was a Berkshire, and consequently they must have at least fifty per cent of Berkshire blood in them. Mr. Stickney was one of the earliest importers of Suffolk pigs, but he says he has given them up, as their thin skin and light hair render them unsuited to the prairie wind and hot sun. He now proposes to try the Essex. I must confess I can not see why a white pig will not stand the sun and wind as well as a black one, but certainly Mr. Stickney can have no prejudice against the Suffolks.

Hardin Co., Ky. He has a farm of 75 acres. Hay sells for \$14 per ton; corn 40c. per bushel; wheat 90c.; oats 20c.; early potatoes 75c.; late potatoes 50c. per bushel, and cabbages 4c. per head. He asks, "What crop would pay best? Would it be better to keep stock? if so, what kind? Will it pay to subsoil?"—I have not much faith in the immediate benefit of subsoiling, but it would be well to try it on an acre or two. At the prices named, potatoes and cabbages ought to pay better than any other crops. But it is necessary to make the land rich, and this can only be done by keeping stock and making good manure. I am inclined to think that for a few years to come "H. L. W." would find pigs more profitable than any other stock.

"H. B. G.," of De Kalb, Ill., writes: "In your work on the pig, page 141, is a table giving the value of manure in producing 100 lbs. of pork from different kinds of food. The valuation is evidently too high for Illinois. What would be a fair basis for this State? Corn is worth 50c., oats 40c. per bushel; timothy hay, delivered, \$7.50 per ton."—This is a very difficult question to answer. The table is correct, so far as it goes. It shows accurately the comparative value of manure obtained from different foods. In other words, if the manure from a ton of wheat straw is worth \$2.68, then the manure from a ton of meadow hay is worth \$6.43, and from a ton of clover hay \$9.64, and from a ton of corn \$6.65, and from a ton of peas \$13.38. If the manure from a ton of straw in Illinois is only worth \$1.34, or half the above estimate, then the manure from the other foods will only be worth half. The actual money return from the application of manure to land depends a good deal on the price obtained for the crop. If you were raising onions or potatoes at 50c. to 75c. a bushel, manure would be worth fully the price given in the table. With wheat at \$1.75 per bushel, and hay \$25 per ton, I think the table is not too high. But if you are raising corn at 25c. a bushel, manure would be worth very little—or land either. Timothy hay, delivered, at \$7.50 per ton, can not be a very profitable crop, especially considering that its removal from the farm tends to impoverish the soil. Whatever manure may or may not be worth, it seems certain that those farmers will ultimately make the most money who feed out to good stock all the hay, corn, and oats they raise rather than to sell them at the above prices. I would, however, rather sell oats at 40c. per bushel than hay at \$7.50 per ton. Here, it costs me \$2.50 per ton to deliver hay, but we get \$25 and over per ton for good timothy. This pays very well, provided you bring back a ton of bran for every ton of hay sold.

When and How to Go West.

Much unnecessary suffering and disappointment may be avoided if those who have determined to go West should know exactly what difficulties they will meet with and what obstacles they will encounter. It profits little an empty-handed man to stand upon a soil as fertile as may be, and it is an aggravation of his poverty that the air he breathes only invigorates an appetite which he has nothing to satisfy. Labor is a drug where every man is a laborer, and where one's neighbor is as poor as himself. Yet the temptation of a free homestead attracts many men with dependent fami-

lies into situations where without available means poverty becomes actual destitution. Besides, the most available homesteads are now occupied, and the further from a railroad and a town a new settler is, the more helpless he becomes. For this reason we would dissuade the settler who depends upon his labor for his living, and who can not afford to remain idle for a year or two, from going any farther than the point where he can secure work. The man who can take \$1,000 or more along with him is independent of circumstances, if he has only wit and smartness sufficient to keep himself from making glaring mistakes. All other men, as a rule, would find it better to keep from the frontier and remain where they are, or not to go so far out, but seek those places where land is still cheap and where their labor can be made available. For the man with some money, the lands remote from the railroads are not the best. He may there procure a homestead free, but its actual cost in the five years needed for its acquisition will be more than that of a tract near the railroad, even if it be bought at \$10 per acre. The time lost in going back and forth for supplies, and in marketing his crops, will soon amount to the value of 160 acres near a town at \$10 per acre. The comfort to him and his family of being near a town will be an important consideration. If he is not suited there will be many chances to sell out to new comers, but in the back country he can not do this; he must simply stay there or abandon his improvements. Now is the season to go West. About this time last year we saw a farmer from Missouri arrive upon a tract in Reno Co., Kansas, which he had purchased from the railroad company, and his mode of procedure struck us as so business-like and successful that we describe it as a model. He arrived with two covered wagons, in which he had his family, his household goods, some plows, and other implements. As he drew up upon his lot, which he had previously selected and staked out, he hauled a plough out of one wagon, and, unhitching the team, hooked on to the plough and commenced breaking the sod. His two boys tethered the cows, brought out a tent and pitched it, set up a stove, and the old lady began housekeeping. The family arrived early in the morning, and as we returned past their camp, in the afternoon, there were two ploughs at work; a hedge-row had been broken around 160 acres, and the teams had already commenced breaking a 40-acre lot for corn. The old gentleman told us he intended to break 80 acres before he stopped to build his house. If every one who went to the West was so well prepared as this man there would be fewer disappointed settlers. All the hardships incident to such a life must be submitted to patiently and willingly, or the man who goes West had better have stayed at home.

Making Drain Tiles.

In places where there is a supply of clay, and which are so distant from a manufactory of tiles that the freight is too costly for their profitable use, it would be better to manufacture them where they are to be used. If the quantity to be used is not more than one or two hundred thousand, a cheaply constructed hand machine can be used. Where larger quantities are desired, some of the various horse-power machines costing from \$250 upwards would be more suitable. A very effective hand machine is shown in the annexed en-

Here is an interesting letter from "H. L. W."

graving, fig. 1, which can be made by any mechanic, and which is capable of making 300 tiles per hour. It is a wooden box divided into two compartments; in the rear one there is an upright post by which the machine may be bound to a tree or a firmly planted fence-post. A lever is hinged to the upper part of this upright post and is attached to a plunger which fits into the forward compartment of the box. At the front of this compartment the dies, shown at fig. 2, are fastened into an opening. The clay, already tempered and worked until tough and plastic, is shoveled into the box;



Fig. 2. DIES.

the plunger is brought down by the lever and the clay is forced by the pressure through the dies. The tiles thus molded are run out upon a table which rests upon rollers, and which moves forward with the tiles. A fresh supply of clay is put into the box, the plunger is again brought down and the tubes of clay make another move forwards. When the table is filled a frame upon which fine brass wires are stretched is brought down upon the tiles and cuts them into proper lengths. The dies are made of an iron plate, the central core is held in its place by a bent crossbar of iron. Various dies, of course, are needed to suit the different sizes of the tiles. The inside of the die-plate is shown at fig. 2.

As the tiles are cut they are picked up by a boy with the pronged holder seen lying upon

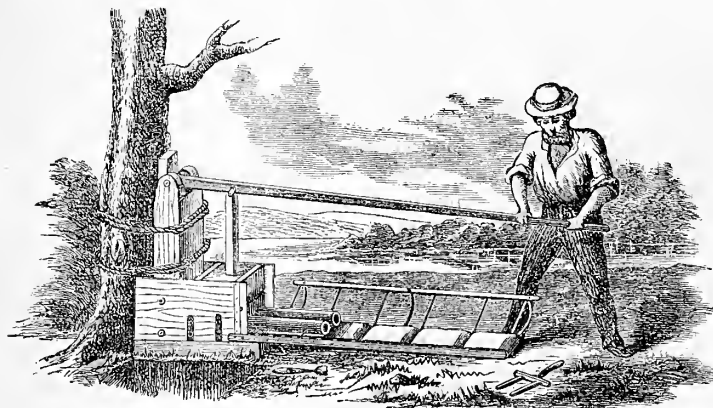

Fig. 1.—TILE-MAKING MACHINE.

the ground near the machine in fig. 1. The prongs should be as long as the tiles and should fit them closely, so as to prevent any injury in removing them. They are carried upon the holder to a level drying ground or are placed upon racks to dry. When dry they are laid up in a kiln to be burned.

Poultry Farming.

There is something alluring in doing things upon a large scale. The desire to possess a thousand fowls has enticed many men to go into poultry farming as a special business, and indulge in dreams of an easy and comfortable business if not of wealth. Unfortunately in nearly every case which has come to our knowledge, there has been failure, at first disappointment, then disgust and sickness of heart from the hope deferred, rather than from any inherent impossibility of keeping a thousand fowls as easily as a hundred. It would seem as though a person who could successfully manage one small flock could manage several with equal success, but in reality few persons manage a flock of a hundred fowls with com-

plete success. There are deaths, sickness, wormin, losses of eggs, hidden nests, and the loss of broods, depredations of hawks, owls, skunks, or cats, and all the other ills from which poul-

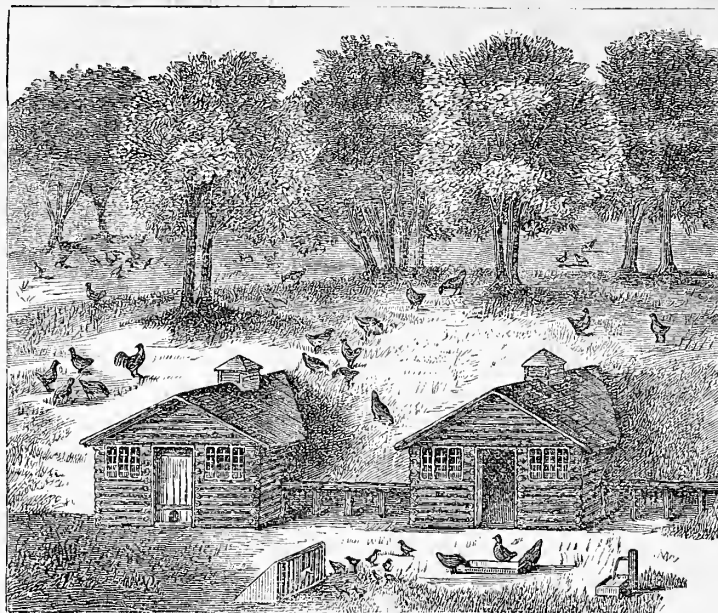

HILL-SIDE POULTRY-HOUSE.

try suffers by reason of neglect or want of skill in the great majority of small flocks; but because of the small value involved nothing is thought of these losses. We always hear, however, when a man fails in his endeavor to man-

age a poultry farm. The cause of the frequent failures is not the impossibility of succeeding, but the want of the care, skill, and patience necessary for success. With these qualifications, a suitable locality, and a proper arrangement of buildings, we know of no reason why poultry keeping for eggs and chickens should not be made profitable with the use of a moderate capital. We know of a case in

which it was successful so far as it was carried, and have no doubt that it might have been indefinitely enlarged with equal success. For the information of those who have requested such information, we describe the plan.

The farm was a tract of cheap land, rough, hilly, and with too many large stones in the soil for cultivation. There was some young, second growth of timber upon the hill-side and a spring broke out near the foot of the hill. Excavations were made in the bank and log houses built therein, all but the front being covered with earth. The houses were 18 feet long by 12 wide, and about 6 feet high to the eaves. The roof was of rough boards, and a large ventilator was placed in the center of it. The arrangement is shown in the accompanying engraving. The soil, of coarse gravel and very dry, was left to form the floor of the house. Roosts for one hundred fowls, and boxes for nests were put in each house, and in the space of twelve feet or thereabouts left between the houses, some places were fitted for nests with logs and earth. The houses were whitewashed inside and outside. The water of the spring was brought in a half-inch lead pipe near to the houses and ran into a trough. Two

hundred hens were kept in the two houses without any trouble, and were free from lice and all disease when we last saw them. They had a range over seventy-five acres of ground, which

was only partly in a poor sod, the rest being gravel or sand with a plentiful growth of blackberries and dewberries. Corn, barley, oats, and wheat screenings were used for food, and the young man who owned and ran the farm was well satisfied that he could add more houses year by year until his hill-side was fully occupied, and still succeed. The warmth of the underground houses kept the hens laying through a greater part of the winter when eggs were selling at a high price. The fowls were common native ones which were purchased from

the neighboring farmers, but they were all pullets of the previous year. To this fact as well as to the care and tact with which they were managed, the success was probably in a great measure due. To the numerous inquiries now before us relating to this business we would say, that if some such plan as this were followed upon a piece of cheap land near a village or city which would furnish a market for fresh eggs in the winter at not less than twenty-five cents a dozen, and for early chickens at not less than twenty-five cents a pound, with proper care, close attention, a watchful eye, and quiet patience with the wayward flock, a reasonable profit might be made out of a small investment.

Unloading Corn-Ears.

"J. S. B.," Nebraska City, describes a plan of unloading corn-ears which we illustrate in two engravings. The labor and the time required to unload a large crop of corn-ears, with the help of a common scoop shovel only, are very great, and some means are needed whereby

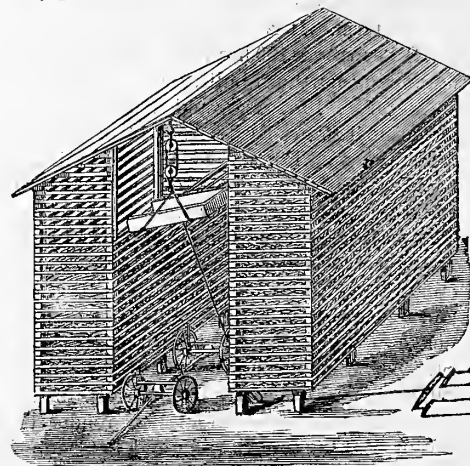

UNLOADING CORN FROM WAGON-BOX.

a whole load may be elevated and emptied into the crib. The following plan of doing this is described by "J. S. B." Where there is a double corn-crib, several hooks are fixed to the rafters at their junction at the peak of the roof. A set of blocks and tackle is suspended to

either of the hooks, the rope from which passes beneath a pulley or roller at the bottom of the crib. Rings are fixed to the sides of the wagon-box, and rope slings are made provided with hooks to fit these rings. When a load of ears is brought from the field the slings are hooked to the rings of the wagon-box and to the lower

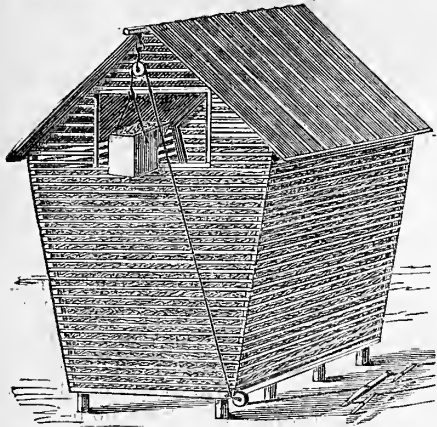

Fig. 2.—UNLOADING CORN-EARS.

block of pulleys, and the team is hitched to the rope. The whole load is then elevated, and when high enough the box is turned, the end board loosened, and by means of a hook the rear end of the wagon-box is fastened to the crib. The team being carefully driven ahead, the front of the box is raised and the corn is shot out into the crib. If there is only the common open crib usual in the Western corn regions a frame of poles may be erected to which the hoisting tackle may be fastened. To adapt the plan to a small corn-crib we suggest the contrivance shown at figures 2 and 3. It is to provide boxes which fit in pairs upon the frame of the wagon instead of a wagon-box. Rings are fastened to the sides of the boxes. A floor with low sides and ends is made to receive them. As the corn is gathered the baskets are emptied into the boxes, and when the whole of them are filled they are taken to the crib. Here they are hoisted one by one by means of a rope passing over pulleys (as hay is hoisted on a hay-fork), and emptied in at the door of the crib. One side of the box is made sloping and projecting, so that the corn is readily dumped, the sloping lip resting upon the sill of the door of the crib. If the boxes are made twenty inches square and twenty

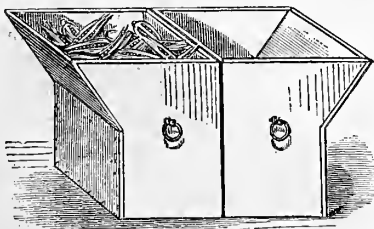

Fig. 3.—BOXES FOR CORN-EARS.

inches deep they will hold about three bushels of ears each. Fourteen boxes of this size can be used in a space of twelve feet. If the wagon-box is of that length, a load of over forty bushels may thus be drawn at once. If the wagon is made to contain sixteen of the boxes about fifty bushels may be drawn at a load.

FRAUDULENT BUTTER.—From the outset we have discouraged the manufacture and sale of the so-called "suet butter" as a fraud upon the consumer as well as the dairyman. In no sense can the stuff be called butter, and we are glad to see that at last the sense of the dealers in

butter is aroused, and that a demonstration is making against "oleo-margarine," or fat, suet, tallow, or whatever it may be, churned in sour milk and packed and put upon the market as butter. In just so much as this fraud may be perpetrated is the market value of butter depressed in the market. Because as there is an established market for butter of poor grades amongst poor consumers and bakers in the cities, anything which may dispute the position in the market of this class of butter makes it unsalable, and affects the entire market by an accumulation of stock. Therefore factory-men, dairymen, and even makers of the "gilt-edged butter" are directly interested in preventing this stuff from coming upon the market as butter. Let it be sold for what it really is—a preparation of tallow; this the makers of it have a perfect right to do, but when it enters the market as butter of any kind it usurps a place to which it has no right, and becomes a fraud and a thing to be discouraged. The New York Butter and Cheese Exchange has at last determined to interfere to protect the interests of their clients, and to obtain such legislative action as shall enforce the use of a proper and descriptive brand upon this spurious article, and to deny it a position of any character whatever amongst dairy products.

A Portable Fence.

By and by the interior fences upon the majority of farms will be abolished. As farmers learn the value of economy they will no longer

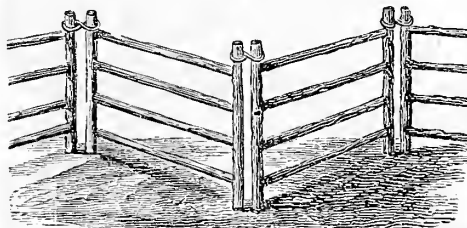

A PORTABLE FENCE.

submit to the enormous wastes caused by these fences, and will either fence their pastures only, or use portable or temporary fences which can be readily taken down, moved, and replaced elsewhere. We give here an engraving of a hurdle fence which is made of panels of light poles, strips, or boards, and which are connected together by means of wire rings or loops of light rope. They are placed in a zigzag position so as to support each other, and each panel may be used as a gate as occasion may require.

CONSUMPTION OF FEED.—

A horse will consume 18 lbs. of hay and twelve quarts of mixed oats and corn, ground into coarse meal, per day. A cow will need 18 lbs. of hay and 6 quarts of meal if she is milking. If at pasture three quarts of meal may be profitably fed per day. 100 hens will require 100 bushels of corn in a year, in addition to what they can pick up on their range. They will need very little corn in the summer, but at least a quarter of a pint a day in winter. The quantity of corn needed by a hog depends much upon its size, breed, and appetite, in all of which hogs differ very

much. It would be safe to allow half a bushel of corn, ground into meal, a week for a hog of 100 to 150 pounds, and more in proportion for larger ones. At fattening time there can be no limit given; the hog should have all it can be induced to eat or made to digest.

A New Harrow.

The harrow shown in the annexed engraving is one made by Messrs. Carr & Hobson, of Beckman street, New York. It is specially designed for strength and indestructibility—being

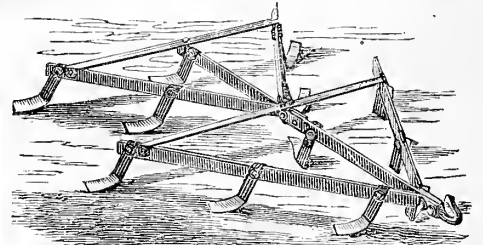

AN IRON AND STEEL HARROW.

made wholly of iron and steel—as well as for mellowing the surface, destroying weeds, and for evenly covering seed. As an implement for working either a summer or a fall fallow it is very effective, while for covering seed it is a far better implement than the common harrow, which leaves a large portion of seed upon the surface and covers another portion too deeply. The action of the teeth is to turn over the soil so as to cover the seed very evenly and yet leave the surface without ridges. Upon newly plowed sod it will also do excellent work. The teeth are of cast steel, sharp and very strong, and clear themselves so perfectly that nothing can possibly be retained upon them while the harrow is at work, so that manure may be evenly spread with the implement if desired.

A Convenient Farm-House.

"Subscriber" asks for a plan whereby he can build a small house to which by and by he can add a front, and thus secure as many conveniences as possible without unnecessary present expense. The plans here shown will probably answer the purpose. The detail may be altered to suit almost any circumstances, but as they are here given they were found very convenient as a farm-house for a small family

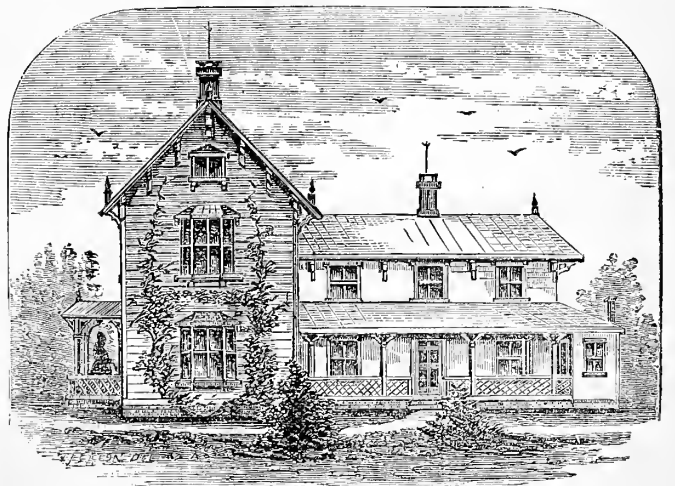

Fig. 1.—FARM-HOUSE COMPLETED.

by the writer some years ago. The part to be built first is the rear portion. This consists of four or five rooms, two below and two or three above with a wing containing a dairy and

wood-shed. The ground plan will be seen in fig. 2, attached to that of the front portion of the building. There is a hall between the two lower rooms with a staircase leading to the rooms above. A hall also separates the upper

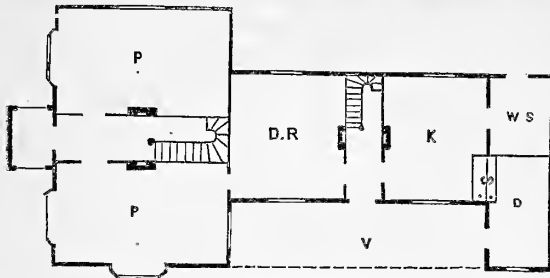

Fig. 2.—PLAN OF GROUND FLOOR.

rooms. The right-hand lower room is intended for the kitchen, in which there is a sink and a pump, seen at s, from a cistern under the dairy. There is also a sink and pump in the dairy, seen at s. The dairy is entered from a door upon the covered porch and is provided with a chimney, so that a stove may be used to warm it in the winter. It should be placed upon the north side of the house. Behind the dairy is the wood-shed, having a door connecting it with the kitchen. Part of the upper hall is partitioned off and made to serve for two closets, one for each bedroom. A chimney is built upon each side of the hall from the ground upwards in which fireplaces may be made in each room; these chimneys connect beneath the roof and are brought into one stack above it.

When circumstances require the front to be built, it is added to the rear part. This portion consists of two rooms below and two above with halls and an open staircase which makes a turn as it enters the upper hall. The plan seen at fig. 3 shows the interior arrangements sufficiently without further explanation. The elevation of the building is seen at fig. 1. A porch runs along the front of the rear building, to which a glass door may lead from the front parlor. There are bay-windows in each of the front rooms and a covered porch protects the front floor. The size of the building and that of each room would of course depend upon the taste or necessities of the occupant. The house to which this description applies was 36 feet

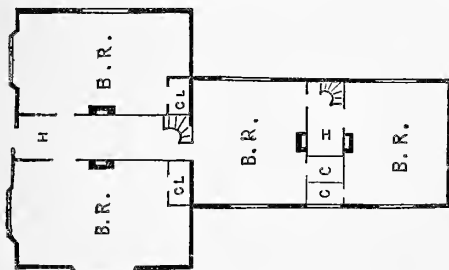

Fig. 3.—PLAN OF UPPER FLOOR.

by 12, and 16 feet high in the rear part; the dairy and wood-shed were 20 feet by 12, and 9 feet high. The front part of the building was 36 by 18 feet, and 20 feet high. But the narrowness of the rear portion was a mistake and it should have been 18 instead of 12 feet. Almost always a person who builds anything makes the same mistake, and it is better to have too much room than too little both in houses and barns.

COMPARATIVE VALUE OF WOOLEN WASTE AND GUANO.—The waste of woolen mills is a very valuable fertilizer. Wool contains 17 per cent of nitrogen, equal to 20½ per cent of am-

monia, which is a larger proportion than most of the best guanos contain. But it is slow in its action, because the ammonia is undeveloped, or what is known as potential, and some years elapse before its full effects appear. It is therefore a lasting manure and very well fitted for permanent meadows. Its money value is difficult to fix, because it is very rarely sold here as a fertilizer. In England it brings in the market \$25 to \$50 a ton, according to its purity or freedom from grease and sand; at the same time guano sells for \$70 a ton. It is used as a top dressing upon grass, or is plowed in along with the clover sod for following crops. The liquid waste of a woolen mill should be composted with earth or spread upon grass.

front of the box is brought snugly up to the teeth of the cylinder. The roots are shoveled into the box at the top and are rapidly reduced to a fine pulp by the action of the sharp chisel points; the pulp is thrown out at the bottom of the box, where it is received upon an apron of plank, and from that it falls upon the floor or into baskets placed to receive it. A driving pulley is affixed to one of the gudgeons so that it may be worked by a belt from a horse-power. It is too heavy a machine to be worked by hand, although a small machine might be constructed upon the same plan if thought profitable to do so.

Raising Ducks.

It by no means follows, because ducks are a water-fowl, that much water is required to raise them. Yet this is a very common impression, and multitudes of farmers and villagers deny themselves the enjoyment and profit of a flock of ducks because they have no pond or stream near the house. It is true that adult ducks will get a good deal of their living out of a water privilege, if they have one. It is not true that water to swim in is essential to their profitable keeping. They want some range and grass and good fresh water to drink every day. Ordinarily, ducks can be profitably raised wherever hens can be. They make a pleasing variety in the poultry yard, and all who have room for them can enjoy them. The first thing in raising ducks is to get them out of the shell, and for incubation we decidedly prefer hens to ducks. They sit more steadily, and take much better care of the young. The wetting of the ducks' eggs daily in the last two weeks of incubation is even more necessary than for hens' eggs.

In a recent visit to a poultryman who has just started in duck-raising, he showed us five young Pekin ducks and six dead ducks, well dried up in the shells, from a sitting of twelve eggs. He had not learned the secret of wetting the eggs. This is sometimes done by sprinkling water upon them, but we think it better to take them from the nest and put them in a basin of tepid water about blood-warm. This moistens the whole shell without chilling the embryo life within. The ducklings out of the shell may be allowed to remain upon the nest with the hen for a day. The hen may then be put upon a grass-plat, under a coop, where the ducklings can go in and out at pleasure. Or if the hen is allowed liberty, the ducklings should be confined in a small pen from which they can not escape. A dozen in a pen ten feet square is enough, for the first two weeks. For water they only want a shallow pan—so shallow that they can not swim, and in which they can wade at pleasure. The water should be changed often and kept in good drinking condition. For the first food nothing is better than the yolk of hard-boiled eggs or boiled liver, chopped very fine. The food had better all be cooked for the first week. It may then gradually be changed to coarse sealded Indian meal, oatmeal, wheaten grits, or rice, as suits the convenience of the feeder. Bread-crumbs and sour milk are excellent food, as are angle-worms and snails. They are quite as good as chickens at devouring insects, and nothing seems to harm them but rose-bugs, against which they should be jealously guarded. For this reason they should be kept away from grave-vines and other plants specially attrac-

A Hook for Side Boards.

Frequently when drawing manure, stone, wood, or such coarse materials, it is not desirable to use a good wagon-box, but rough side boards or planks put in its place. Then these persist in falling down when they ought to stand up, and a person's temper is tried, and

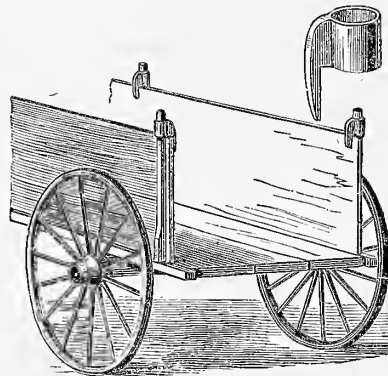

HOOK FOR WAGON SIDES.

very often fails, with the usual results in such cases. All this may be prevented by using this simple contrivance. It consists of a ring of iron large enough to slip over the stake of the wagon-box and has a claw attached to one side. When the ring is on the stake the claw is placed inside of the plank or side board and holds it in position. Both the hook and its application are shown in the engraving.

Root Pulper.

The accompanying engraving shows the section of a root pulper which is readily and cheaply made, and which grinds the roots into pulp very rapidly. It consists of a cylinder of hard wood 16 or 20 inches in diameter turned exactly round and smooth, and of whatever length may be desired. This is mounted upon gudgeons and armed with steel teeth made of half-inch square steel. The teeth are ground to a chisel point and are screwed into the cylinder with the bevel of the points upwards and projecting half an inch. This toothed cylinder is fitted into a box of hard wood plank and the box is supported upon a stout frame which should be firmly bolted to the barn floor. The

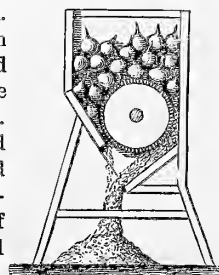

ROOT PULPER.

five to these insects. As the ducklings grow older they may have more liberty and a greater variety of food. If they have not plenty of grass its place should be supplied by lettuce, onions, cabbage, or other green succulent food. If you desire exhibition birds of the largest size, it is particularly important that the ducklings should be fed regularly, and at frequent intervals, having all the food they can digest. Five times a day is none too frequent feeding. We have usually succeeded quite as well with ducks as with chickens in a village yard. When grown, we give them a larger range. *

Future Prospects of Wheat Culture.

It has now become a settled fact that in the future the wheat product of Great Britain will steadily decrease. The importations into that country the present shipping season will not be far from 100,000,000 of bushels. It is the demand for this vast quantity of grain that has kept up the price in our own markets to a profitable point; and it is the future demand that will govern the price of our wheat in the future. If that demand shall keep even with the surplus which we have to spare the price will be satisfactory; but if our production shall overrun the necessities of our foreign customers, the price will be so low that it will not pay the cost of producing it. The fact, therefore, that large tracts of land in Great Britain and Ireland have been withdrawn from wheat culture and have been turned into grazing fields and the production of meat, and that American fields are now looked to for the supply of grain, should not tempt us to go out of our way to largely increase our wheat production. On the contrary, our plan is to follow their example, to keep our wheat production stationary, and to increase our stock of beef cattle, sheep, and hogs, as much as possible, so as to supply ourselves and leave only a moderate excess for shipment. If Europe needs 100,000,000 bushels and we have but 90,000,000 to dispose of, the price of that 90,000,000 and that of all we need at home, in fact the price of the whole crop, will advance up to the extreme point that our customers can pay. But if we have but a small quantity over their needs the price of our whole production will depend upon what they are willing to pay. It would not then be wise to increase our growth of wheat, but rather to turn our attention to growing grass, and our meat and dairy products.

How to Manage Sitting Hens.

A good deal of the success of the poultry crop depends upon the management of the birds while sitting. Hens that steal their nests and follow their own instincts do very well if they are not disturbed, but frequently they get frightened or robbed, and the eggs are lost. As a rule, it is better to have all the sitting birds completely under your control, and make them follow your will rather than their own instincts. With a well-arranged poultry house it takes but a little time daily to have all the birds come off for food and exercise. But without this we manage to make the sitters regular in their habits. We usually set the hens near together in a sheltered sunny spot in boxes, or barrels, that we can cover, and thus perfectly protect them against enemies, and at the same time compel them to sit until the box is uncovered. Wherever they may lay, when they want to sit we remove them to the

hatching-yard by night, and put them securely upon a nest full of eggs. We usually take Asiatic fowls for mothers, as they are very contented upon the nest, and cover a large number of eggs. We have never failed to make them take kindly to a new nest. They also bear handling better than most other varieties, and are very patient, good - tempered mothers. Every day about twelve o'clock we remove the covers, and carefully take the hens from their nests for food and water. In pleasant weather they have from a half hour to an hour to scratch in the dirt and take their dust bath. Most of them return to their nests voluntarily before the time is up. Occasionally a bird will take to the wrong nest. It takes but a few minutes to see every bird in her place, and make her secure for the next twenty-four hours. As the hatching time approaches, we dip the eggs in tepid water every day to keep the pores open, and to facilitate the hatching. This moistening of the eggs we have found of special service in the hatching of the eggs of water-fowl set under hens. By this method we have good success with sitting hens. *

A Corn-Marker.

The annexed engraving is one of a marker for corn or potatoes which we recently saw in use. It is a very light, neat, and useful implement for those who plant these crops by hand in check rows. The markers are strips of plank four feet long, two inches thick, and six inches wide, into which gains are cut to fit the crossbars. Iron straps are fastened over these gains, in which holes are made. Holes are also made in the crossbars, and as the markers are moved along the bars, as they may be set wider apart or otherwise, they are held in their places by iron pins inserted in the holes. The crossbars are connected by two flat iron rods, and a tongue is fixed and braced to them. A handle is also fixed behind to guide the motion. At the rear end of each marker wings of wood are attached by

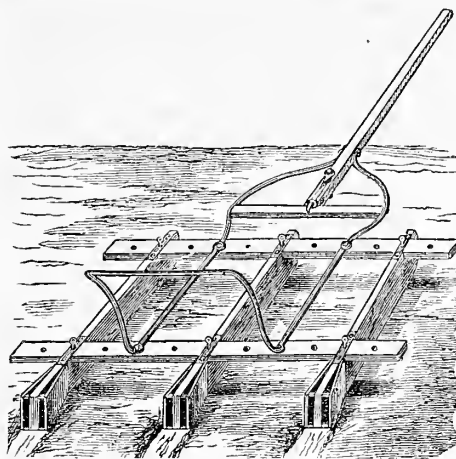

A CORN-MARKER.

which furrows are made. The seed is dropped into these furrows at each intersection of the cross furrows.

FEEDING MEAL TO COWS.—The best way to give meal to cows is either to mix it with some cut hay, moistened so that the meal will adhere to it, or to seald it and give it in the shape of a thin gruel as a drink. In the first place it is necessary to perfect digestion that the saliva should be mixed with the food and that the food should be returned from the first stomach to the mouth for a second chewing or rumina-

tion. This is only done when the food is bulky, requiring considerable chewing. In the second place the gullet, or passage from the mouth to the stomach, in ruminants, opens directly into the third stomach, having intermediate longitudinal openings closed by lips, by which the food enters the first and second stomachs. If the food is bulky and solid it separates the lips of these openings and finds an entrance to either or both the first and second stomachs. If otherwise, it passes over the closed lips and enters the third stomach. In the first case, by a periodic inverted action of the gullet, the food is thrown in small quantities from the stomachs to the mouth, where it is reduced to a soft semi-liquid condition, in which state it is passed easily to the third stomach for digestion. In the second place it misses this process of rumination, and is therefore not in a condition for perfect digestion, and the meal is seen to pass away in the dung in considerable quantities unaltered.

THE TIMBER CULTURE ACT.—A recent amendment of the Act of Congress to encourage the planting of timber upon the western prairies, provides that 160 acres of land, or less, may be entered by any person who is the head of a family or who is 21 years of age. One fourth of the land shall be planted with trees. One fourth of this required quantity must be broken the first year and planted the second year. Another fourth must be broken the second year and planted the third, and the remaining half must be broken the third year and planted the fourth. After eight years' cultivation a deed will be granted. The fees are \$18 for each entry.

How to Kill Skunks.

During all the breeding season, sitting hens, ducks, geese, and turkeys are exceedingly liable to the depredations of skunks. These creatures forage in the night, and will come into sheds, barns, and cellars in quest of food. They are very fond of eggs, and when they have once got a taste of this delicate food they will come so long as there is an egg left. If a dog is set to catch them, the skunk carries too many guns for his enemy, and the result is a perfumed watchman upon the premises for the remainder of the season. If trapped or shot he dies game, and not infrequently leaves a gamey odor in one's clothes that puts them permanently upon the retired list. A correspondent to whom we sent some choice Rouen ducks' eggs last season was robbed by one of these marauders, and we are indebted to him for the following method of destroying skunks, which we give in his own language: "A skunk got at the nest, and sucked all but two of them before we suspected that it was not the hen that broke two eggs every night. She was sitting in a cellar carefully guarded, except the drain, which had an outlet about fifty feet from the building; it was through this the skunk came in. As soon as we suspected the true cause of the mischief we closed the drain, and I sucked out a part of the contents of an egg through a small hole in one end, and put in a little powder of strychnine, shook it up well, and covered the hole with court-plaster, and left it at night near the mouth of the drain, which I had closed up. The next morning the egg was partly eaten, and about two rods distant lay a dead skunk. I think this is the best way, in

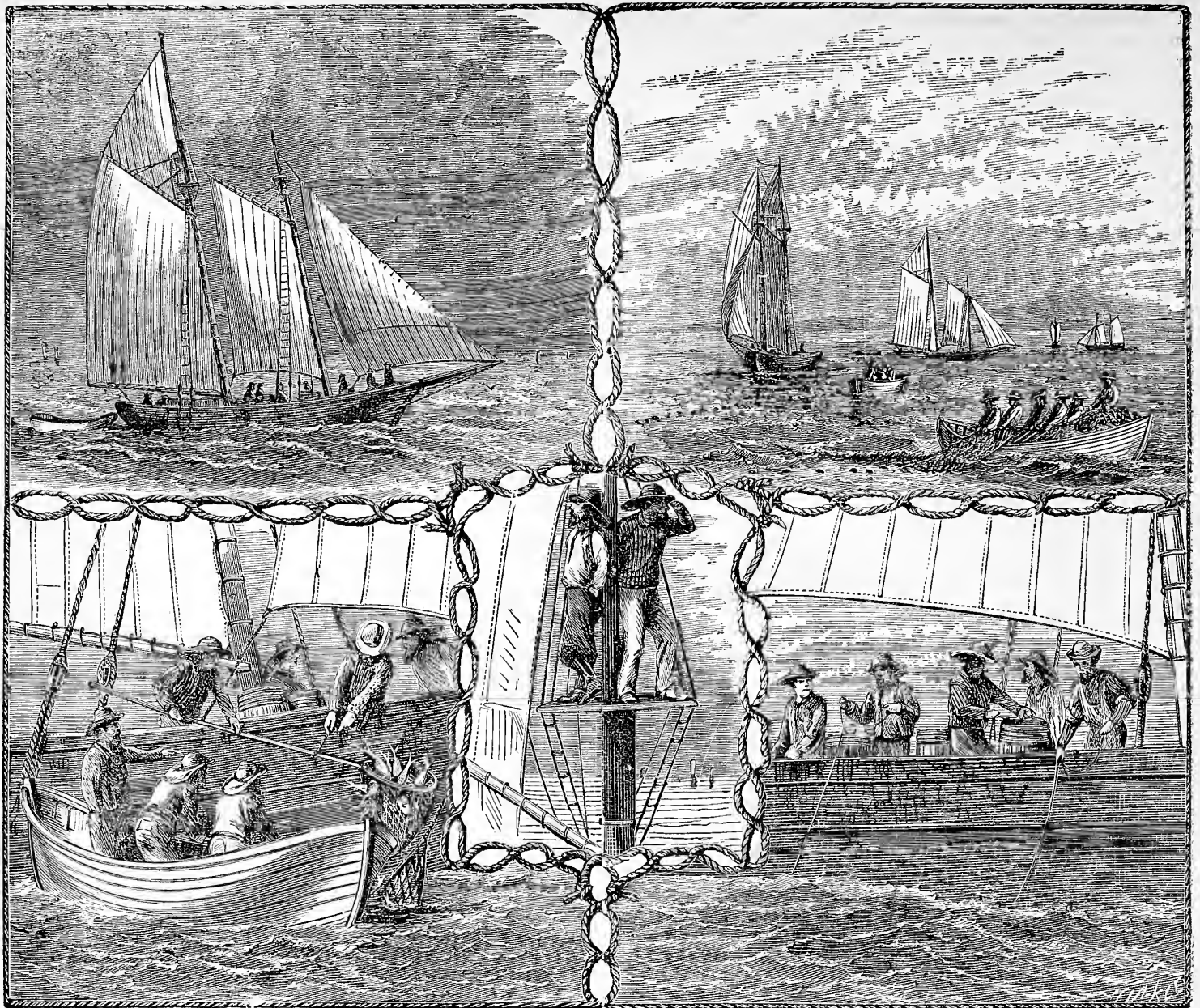

MACKEREL-FISHING.—Drawn and Engraved for the American Agriculturist.

careful hands, of 'killing the varmints,' as there is no unpleasant smell which usually accompanies the shooting or trapping them, and it is a dead sure thing."

It would be better indeed if we had suitable poultry houses where sitting birds could be perfectly protected, but as a matter of fact not one farmer in fifty has anything of the kind, and the hens sit where they please. Turkeys almost invariably make their nests in exposed places, and a single skunk upon the premises, if left to himself, will destroy the poultry crop for the season. Use strychnine.

CONNECTICUT.

Mackerel and How they are Caught.

Next to the cod, the mackerel is probably the best known fish, as in a salted state it finds its way to even the most remote inland towns, and is sold fresh in large quantities in all places within easy railroad communication with the coast. The mackerel, *Scomber vernalis*, appears in the markets fresh about the middle of May, and continues nearly to the first of July. When just taken out of the water it is a beautiful fish; the upper part of the body is of a steel blue color, becoming lighter on the sides, while below it is of a silvery white with metallic re-

flections. Extending from the back half way down the sides are 24 to 30 deep blue bands. It is from 16 to 18 inches in length, with a fusiform cylindrical body, its greatest depth being near the last rays of the first dorsal fin. It has an excellent flavor, and furnishes a cheap and savory dish.

Mackerel are very numerous along the Atlantic coast, and are caught by fishing smacks in great numbers from Cape May to Cape Cod. These fish were until late years caught with a small hook, but as fishing became more extensive a new plan was discovered by which a greater number could be caught in less time than with the hook and line. It would take the fishermen, with hook and line, a long time to get a load to bring to market fresh, but now they often get enough in one haul to load their vessel, and there has of late years been an increased quantity brought to Fulton market, which is the great fish depot of New York. When there are a great many fish in market the fishermen salt their mackerel at sea, and avoid a dull sale. The price varies from one to three cents, and is sometimes as low as half a cent per pound. They are, when plenty, peddled through the city by street vendors, and a large number is sold in this way.

The engraving shows the method of catching

the fish with a net. The smackmen have two fishing-boats and a large seine-like net, about 200 fathoms in length and eight in depth, with a large weight of 150 pounds called "Old Tom," fastened to the bottom rope about midway of the net. They have pulleys connected with this weight and small rings fastened to the bottom rope about four feet apart. A long rope is passed through these rings and attached to the pulleys, so by pulling on this rope the men are able to draw up the bottom of the net like a bag. On approaching a school of mackerel the fishermen drop "Old Tom" overboard, and then row around the fish and let out the net so as to form a circle, as seen in the engraving. After the fish have been closely gathered in the net the captain comes alongside the net with the smack, and with a large scoop-net he, with the assistance of the crew, hoists them on board. The engraving also shows how mackerel were formerly caught with the "gig," a method of fishing that afforded much sport to the smack-men. The fish, however, were not always in the humor to bite at the "gig," and the fishermen would often see hundreds of them at the surface of the water at a time and not be able to catch them. The two men standing in the rigging are on the lookout for mackerel.—D. W. MORRIS.

Succulents as Decorative Plants.

BY CHARLES H. HOVEY, CAMBRIDGEPORT, MASS.

The class of plants known as succulents is now attracting much attention amongst gardeners and amateurs on account of their decorative qualities for both the greenhouse and the garden. Their various and often grotesque forms and interesting habit of growth give them a peculiar interest, and afford a never-ending source of study and amusement. Many of them are desirable additions to any collection of plants; some being fine bloomers, lasting in flower from two to three months, while others are indispensable for bedding purposes. Their great tenacity of life, or, in other words, the impunity with which they bear neglect, as also their rapidity of growth when cared for, render them universal favorites.

Of all the plants grouped under the title of succulents the Echeverias will undoubtedly prove the most generally useful. They afford so great a variety in style of growth, and such decided contrasts in color, that in time we shall have our groups of Echeverias, producing a more unique and as striking an effect as we now have from our masses of Geraniums, Coleus, and similar bedding plants. It may be remarked that some botanists include these plants in the genus *Cotyledon*, but as this is still a disputed point it is best in the present article to use the names by which they are known in the collections of florists and in their catalogues. The following species and varieties are some of the most desirable for the greenhouse and garden:

Echeveria agavoides.—One of the rarest and best of the Echeverias; a dwarf, compact grower, with leaves of a semi-transparent green color, tipped with red, exactly resembling in its appearance a miniature Agave.

E. argentea vera.—A new variety from California; leaves six or seven inches long and from one to two in width; the whole plant is completely covered with a thick white powder; this variety most generally grows in clumps, and is very showy.

E. Californica.—Also rather new, from the Pacific coast; with long, narrow, green leaves;

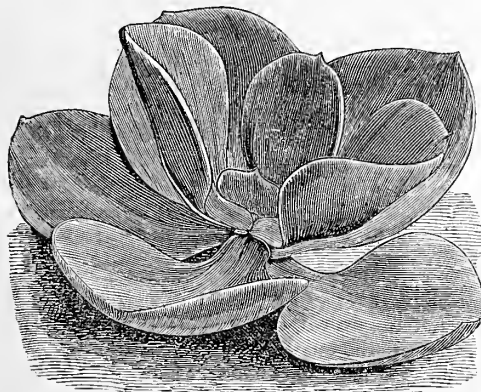

ECHEVERIA METALLICA.

somewhat resembling in style of growth *E. agavoides*; a dwarf, dense grower, and very distinct.

E. farinosa.—Another recent introduction from California; leaves long, narrow, sharply

pointed, and of a beautiful white color; similar to *E. argentea vera*, and one of the best.

E. lurida.—This variety is probably a hybrid from *E. sanguinea*, which it resembles in



ECHEVERIA RETUSA FLORIBUNDA SPLENDENS.

growth; the young leaves are of a bluish red, fading to a rusty brown; a promising species.

E. metallica.—This is the most generally grown of all the Echeverias, and is perhaps the most effective for greenhouse and garden, its large, pink, metallic leaves showing off to great advantage; and its being a very free grower will render it the most popular of all the Echeverias. The engraving shows the appearance of a small specimen.

E. metallica glauca.—Somewhat similar to the preceding, but more compact and regular; leaves large and of a bluish white color; fine for bedding, and a good flowering variety.

E. Mexicana.—A new variety, after the style of *E. secunda glauca*, but much superior; of regular and compact growth, with leaves of a beautiful pale blue color, it forms a perfect rosette, and must supersede all others of its style for edging purposes; synonymous with *E. rosularis*.

E. pumila.—In growth similar to *E. secunda*; leaves long, narrow, and of a glaucous, green color; a distinct variety.

E. racemosa.—A variety said to be a hybrid from *E. sanguinea*, which it resembles in growth; leaves of a pinkish, salmon color.

E. rosea.—Resembling the Cotyledons more than the Echeverias in growth; leaves green, slightly tinged or edged with red.

E. retusa glauca.—A strong growing variety, with glaucous, green leaves; one of the best flowering varieties.

E. retusa floribunda splendens.—The best of all the Echeverias for flowering; flowers a brilliant scarlet, and a very free bloomer; similar in growth to *E. retusa glauca*, but with narrower leaves. See engraving.

E. sanguinea.—A distinct species, with long, narrow leaves, slightly channeled, and of a dark red color; fine for bedding in contrast with the light-colored varieties.

E. scaphophylla.—One of the newest of the Echeverias, a hybrid between *E. agavoides* and *E. linguæfolia*; leaves blunt, and slightly channeled like the latter, but in growth and color similar to *E. agavoides*.

E. secunda.—An old variety with green leaves; a dwarf and compact grower, and fine for bedding.

E. secunda glauca.—One of the best for bedding; similar to *E. secunda* in growth, with leaves of a bluish white color; next to *E. metallica*, perhaps the most generally grown. A small specimen is shown in the engraving.

E. secunda glauca major.—New and fine; a large variety of *E. secunda glauca*, with leaves not quite so light colored.

E. secunda ramosa.—A monstrosity in habit of growth; stem flat, broad, and covered at the top with numerous small green leaves; in appearance resembling the flower of a Cockscomb.

E. nuda, *E. linguæfolia*, *E. lutea gigantea*—are all very similar to *E. retusa glauca*, and are all good flowering varieties.

Of the above varieties, the six most distinct in style of growth and contrast of color are *E. metallica*, *E. Mexicana*, *E. farinosa*, *E. agavoides*, *E. sanguinea*, and *E. metallica glauca*. All the species and varieties above described may be propagated from

seeds or cuttings, and most of them from single leaves; if raised from seed it should be sown and treated similarly to Cineraria or Calceolaria seed. If propagated from cuttings or leaves they should be laid away on a dry shelf until they become thoroughly dry or callous, and then be potted in a light, sandy mixture and

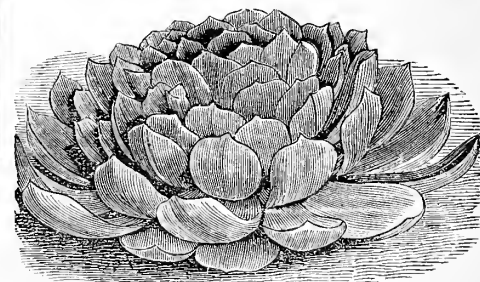

ECHEVERIA SECUNDA GLAUCA.

sparingly watered until rooted. As soon as rooted, if they are repotted in a mixture of leaf-mold or well-rotted manure and loam, with one fifth part sand, they will amply repay the trouble of repotting.

[Last winter we received from Messrs. Olm Brothers, of Newark, N. J., a fine specimen

with the formidable name already given above, "*Echeveria retusa floribunda splendens*." It was so handsome a plant that we had an engraving made from it, which is here given; after the drawing was made the plant kept in flower in our greenhouse for some months.—Ed.]

Improved Mignonette.

Within a few years there has been considerable attention given to the improvement of the Mignonette, and though some of the new varieties that have been sent out have not proved equal to the representations made in their favor, yet we have several that are a decided improvement upon the common form of this old-fashioned garden favorite. A few days ago we received from Mr. James Fleming, seedsman, 67 Nassau street, New York, some spikes of Mignonette that in size were simply astonishing, and having expressed a desire to know more of its history, we are favored with the following account by the raiser, Mr. Samuel Henshaw, gardener to J. C. Green, Esq., New Brighton, Staten Island. Mr. H. says:

"The Mignonette of which I send you a sample is the result of careful selection in saving the seed, thinning, etc., until it is now quite a distinct variety. Three years ago I grew for the first time the variety called *Reseda ameliorata*, which produced flower-spikes about three inches in length; thinking it might be still further improved, I saved seeds of the largest flower-spike, and only the seeds that formed on its lower half. The year following there was a decided improvement, the plants being more vigorous and the flowers much finer. I continued selecting only the finest for seed, and this year the spikes saved for seed for next winter's flowers measure at this date (April 29th) 16½ inches in length, and are still growing. The seeds were sown last fall about the third week in August, in the bed of a small span-roofed house devoted to violets, and treated the same as the violets as to watering, ventilation, etc., air being given freely all winter, and the temperature never allowed to rise to more than 50° at night, and oftener it was about 40°. When the weather was severe the soil was kept rather dry, with occasional doses of weak liquid manure; the plants were thinned to about 12 inches apart, but would have been better if allowed twice this room, as they are now very crowded. The Mignonette for early winter blooming is sown about the end of July in boxes about two feet long by one foot wide and nine inches deep. About six plants are enough to each box. These are placed on the greenhouse shelves in October, and yield abundance of flowers until past midwinter."

This is a useful bit of information, not only to gardeners, but to all who raise flowers or, in fact, any plants from seeds. But few who have not tried it are aware of the decided improvement that may be effected by a proper selection of the flowers for seed. It is too frequently the case that those who intend to save seed wait until the plants have expended their strength in blooming before they gather it, or wait until near the end of the tomato and melon season before they think of next year's crop. It is something to forego the plucking of the earliest and finest flowers or the best and soonest ripened of the garden products. But whoever works in a garden, be it large or small, must have faith, and one exercise of this faith can be manifested in foregoing present enjoyment for the sake of future good.

Evergreens from Seed.

In an article given last March it was stated that the difficulties were so great that we could not advise farmers in general to undertake to raise evergreens from seed. Still the inquiries continue to come, and we will give such directions as can be given, remarking that this is a branch of horticulture requiring the greatest skill and experience, and those who undertake it must expect to meet with disappointment and losses, for these fall to the share of those who have made evergreen growing the business of their lives. One reason why we advise farmers to purchase young evergreens rather than to undertake to raise them is the fact that so few of them like at any time to do what is called "puttering" work, and unless they are willing to give to the evergreens while they are young all the care that they demand, it will be money and time thrown away. But few plants are so "miffy" as these the first year, and our hardiest evergreens when young are as delicate as a tender exotic; and as seedlings two or three years old—an age when they are no longer liable to the troubles of their infancy—can be had at very low rates of those who raise them on a large scale, we are sure that we do farmers a service when we advise them to buy rather than to attempt to grow them. Besides getting serviceable trees two or three years sooner, the time that would be required to raise these seedlings is worth more than the plants will cost. To those disposed to try raising their own trees, we would say that it is now too late to start with any hope of success. The one thing most injurious to the young seedlings is the hot sun; hence the seed must be sown at the very earliest moment. Some growers even sow when only the surface of the earth is thawed, and it is still frozen beneath. To guard against the injurious effects of the sun, the bed must be shaded, and in such a manner as not to prevent a free circulation of air. A very good plan for those who grow upon a small scale is to raise a common hot-bed frame upon bricks or blocks a few inches above the bed, and whitewash the glass. This gives shade and a free circulation of air. On a large scale the beds of convenient width have stakes driven along their edges to which boards six inches wide are nailed, their lower edges being three or four inches above the surface of the bed; upon these boards rest screens made of common lath with the laths an inch and a half apart. The beds of Messrs. R. Douglas & Son, Waukegan, Ill., who are the largest growers in the country, are protected by screens of brush supported upon posts seven feet above the beds, and they have acres covered by this kind of protection; this has the advantage over the other shading that it allows the necessary work to be done without the trouble of removing the screen. The seeds are usually sown broadcast and raked in, the surface being afterwards lightly rolled or pressed. Weeding and thinning have to be done, and a constant watch kept against "damping off." Thousands of seedlings will sometimes decay at the surface of the earth, without any warning; the only remedy for this is to sift on a covering of dry sand kept for the purpose.

Stocks for Fruit-Trees—Peaches.

In discussions with fruit-growers as to the want of success with this or that variety of apple, pear, or other fruit, we have suggested

that an uncongenial stock might have something to do with it, but these gentlemen have not been disposed to adopt this view. In their eyes, one stock is as good as another. Suppose a nurseryman buys a lot of imported or home-raised apple or pear seed; it would be quite within bounds to say that each pound of this contained seeds from a dozen trees of quite different character, not only in the quality of the fruit and its time of ripening, but in the habit of the trees. Some may be regular and others straggling growers, there may be seeds from slow and quick growers, and from those which ripen their fruit in August and those that mature in December. The nurseryman sows his seeds, and when the stocks raised from them are of proper size he buds or grafts them indiscriminately, throwing out, probably, the very unpromising looking ones. To say that a dozen Baldwin apple-trees grafted upon a dozen stocks of widely differing character will, when set in the orchard, all produce fruit precisely alike, is to state something that we can not agree to. In rapidly maturing trees like the peach this matter is more readily tested than with a slow tree like the apple. Entertaining these views, we were much pleased with an article by Col. Edward Wilkins, which appeared in the *American Farmer* (Baltimore) for April. Col. Wilkins is the largest peach-grower in America, and consequently in the world. Having had the pleasure of visiting his immense orchards at Riverside, Md., a few years ago, we know he brings to fruit-growing all the intelligence and shrewdness that a successful merchant applies to his business; he makes peach-growing a business, and a successful one, and has a sharp eye to everything that detracts from or conduces to that success. Having found that varieties of the peach which should ripen some weeks apart would, much to the detriment of the grower, mature very nearly at the same time, as well as other unfavorable indications in his orchards, he has given much thought to the causes of these abnormal peculiarities. In the well considered article to which we have referred he attributes these troubles to uncongenial stocks.

To avoid the yellows the nurserymen try to procure for their stock seed from what is called the "native peach," that is a peach which has long been grown in eastern Virginia from the seed; a very poor fruit, but the tree is remarkably healthy. Col. Wilkins states that there are as many bushels of seed sold as coming from this native peach as there are bushels of the fruit raised. He claims that stocks raised from this seed, from a very poor fruit, grown on a very light soil, are not suitable subjects on which to bud the rich melting varieties which need good soil and culture to bring them to perfection. Col. Wilkins can not see (nor can we) why seeds from healthy budded varieties of the peach should not give more congenial stocks than these miserable "native" peaches. This is not merely a notion with Col. Wilkins, but he gives a bit of experience to support his views. The first orchard he ever had was budded upon stocks raised from the seeds of first-class peaches; this was the best orchard he ever had for size, and health of the trees, and the quality of the fruit. In Europe, where there are no "native" Virginia peaches, we hear of no difficulty resulting from the use of the seeds of good fruit for stock whenever the peach stock is used. In Europe, the peach is generally budded upon some varieties of the plum, which are readily multiplied by layers.

The point of Col. Wilkins's article is that to get peaches true to their kind they should be budded on stocks obtained from healthy trees of the same variety. To restrict the budding to the same variety seems to us an unnecessary refinement, but we would bud clingstones on clingstone and freestones on free stocks, and late sorts we would not bud upon stocks from early varieties, nor vice versa. To the amateur cultivator this matter presents but little importance. He sets trees, and is only too glad if he gets any fruit at all; but to the peach-grower who numbers his trees of each variety by the thousand, the ripening of a sort only three days out of its proper season is a great inconvenience and loss. Another point this gentleman insists upon is that the buds for inserting upon the stocks should be from select bearing trees. It is the custom in nurseries to take buds from trees that were budded the year before, and the growth of these buds will be taken to furnish buds the next year; and so on, always budding from young stock that has never fruited. We are not prepared to give an opinion upon this point, but it is a legitimate subject of inquiry if constantly budding year after year, from trees that have produced wood and leaves only, may not ultimately have an effect upon the bearing qualities of the trees. We regret that we are unable to give Colonel Wilkins's article entire, but we believe we have presented the main points of it. It is a good sign for our horticultural progress that one so largely engaged in fruit-culture gives his personal experience for the benefit of others.

A Trap for Cut-Worms.

There is no trustworthy remedy against cut-worms except actual catching and killing them. Any application to the soil sufficiently strong to injure or discommode them would certainly destroy the crop, and all the recommendations to use salt, carbolic acid, and other similar substances may be set aside as useless in practice. We have trapped them in various ways, beneath chips, stones, and in holes punched in the ground with a smooth round stick, such as an old broom handle. But unfortunately in these cases they are caught only after they have spent the night in destroying the young cabbages or corn. Finally we hit upon the expedient of surrounding the hill or plant with a ring of holes close together, and in this way caught a great many of the pests every night. Making so many holes with a single stick is a slow process, but with the contrivance shown in the annexed engraving, the whole ring of holes is made at one stroke. An old shovel handle is split for about a foot with a fine saw. The split portion is soaked in boiling water to soften it and the ends are inserted into holes made in a hoop or ring of wood two inches wide, one inch thick, and eight inches in diameter. In the bottom of the ring there are inserted a number of pieces of an old broom-handle projecting two inches and placed not more than a quarter of an inch apart. When this is pressed into the earth around a hill of corn or a cabbage plant, it leaves a circle of smooth round holes two inches deep with compact sides and bottoms. The cut-worms fall into these holes in their nightly rambles and may be found and destroyed in the morning.



My Garden Mistakes and Successes in 1873.

BY COL. G. S. INNIS, COLUMBUS, O.

[The following article was intended for April, but failed to reach us in time. It was crowded out last month, and though it is late for some of its suggestions, we give it, as the experience of so skilled a cultivator as Colonel Innis, if put on record, is sure to be of use to some one.—ED.]

TOMATOES.—We had a very fine lot of plants, short, stalky, and branching. We made the mistake, however, of putting them on some very rich land—land that would have produced a fine crop of onions or cabbages, but was too highly manured for tomatoes. This I had learned by experience a time or two before, but somehow we have to learn such things over again every five or ten years. We will not repeat this folly the coming season, but will select good corn or wheat land, rather inclined to clay than sand or loam, for our tomato crop. This moderately rich soil will produce more fruit and less vine, will ripen the fruit more evenly and earlier, and the product will be smooth and of the very best flavor.

CABBAGES.—With our early cabbages we made a success last year. This was done by sowing the seed quite early in a hot-bed; then transplanting into other beds early in March, putting the plants about four inches apart each way. This made us large, fine, and well-rooted plants by the middle of April, when we removed them to the field and then set them 30 inches apart each way in very highly manured land, and had very large solid heads, and early too. Before other folks got in our way we had sold most of them at good prices. We never made much by planting inferior plants of any kind, or by using poor seed, to save the price or labor of obtaining good ones.

MELONS.—With Skillman's fine netted green-fleshed melon we made a fine success. We planted them on the richest land we had. A sandy loam, subsoil of yellow clay, underlaid with sand and gravel. Planted about May 10th, or as soon as the ground gets warm enough for corn or beans, in rows seven feet apart both ways. The greatest enemy of all improved varieties of vines is the yellow striped bug. For this mix three table-spoonfuls of good Paris green in a three-gallon can of water and sprinkle the plant. This is certain death to all insect life. By the way, permit me to say right here that last fall a green-looking worm ate up most of the late cabbage in Central Ohio. It was a rare thing that a patch escaped. Visiting a friend, I noticed they had the finest kind of cabbage heads. Upon being asked how it came that they had such nice cabbages, while other folk's were all destroyed by the worms, the lady replied that she noticed the worms were eating theirs, and took common table salt and sprinkled them quite freely; that it seemed to rust or burn the plants a little at first, but the worms quit at once, the cabbages soon recovered, and made the best crop they had had for ten years. I determined to learn a little from this good housewife. All garden vegetables want to be worked while young, and must be kept entirely clean of weeds or other vegetable growth to insure success. Two crops can not be produced on the same ground at the same time. A crop of weeds and useful plants can not be raised together under any circumstances.

POTATOES.—With the Early Rose, planted very early, we made a success, notwithstanding the Colorado bugs. This variety seems to do best on light, rich soils, heavy wet clays being unsuited to it. The Early Rose, in common with all the early varieties, should be planted as soon in spring as the ground can be worked or made in good order. When this is done they make a crop before the extreme hot and dry weather sets in, about July or August.

Peerless.—This variety yields enormously, and our greatest mistake of last year was in not planting more of them. In 1872 the Peerless were nearly worthless for table use, but last year they were quite good. The reason of this difference seems to me is that the Peerless being a medium early variety, and planted early, ripened in 1872 in a very dry and very hot spell of weather, the latter part of July and first of August, the thermometer ranging in the nineties most of the time day and night. This made the potato deficient in starch, and consequently not good. In 1873 the weather was rainy and very much cooler when they were ripening, and made them of good quality. Were it not for the bugs, I would suggest planting late, say about June 20th, so they would ripen during the cool weather in September.

Thorburn's Late Rose.—This, with us, was a grand success, though I doubt it being a distinct variety, probably a selection from the Early Rose. Potatoes can be changed very considerably by judicious selections.

Campbell's Late Rose.—This variety with us was not a success. It grew vigorously for a time, and promised well, but mildewed badly in two or three days' time, and made a poor crop on very good land.

The Jersey Peachblow was generally a failure in Central Ohio the past season.

Can One be Both Market Gardener and Florist?

BY PETER HENDERSON.

A correspondent from Columbus, Ohio, asks me if the prosecution of the business of market gardening can be profitably combined with that of the florist, and as there are doubtless many readers situated in places where the products of both are wanted I will occupy a short space in reply. On this subject I feel competent to advise, having for many years been extensively engaged in both pursuits at the same time, and have made them both fairly profitable, more so, I believe, than if the two had been separate. This was particularly so in the beginning. Beginning with some ten acres of market garden and three small greenhouses, I employed an average of eight men throughout the year. From April to December our labor was almost exclusively in the market garden, or what little was necessary for the flowers planted outside, these then being of but secondary importance. Our main energies were devoted to the market garden. On the approach of winter, instead of discharging a portion of our hands, as our neighbors who were market gardeners only did, the work then necessary in our greenhouses profitably employed the help no longer required in the vegetable department, thus enabling us to retain a full corps of trained men ready for the busy work in spring, instead of having the annoyance of breaking in unknown and inexpe-

rienced hands each year, the loss from which is rarely sufficiently estimated.

A difficulty with the florist at the beginning is, that the business is usually too small to afford the expense of a horse and wagou, which at some seasons is indispensable; but when he combines his business with that of market gardening the teams necessary for that can be used for the occasional requirements of the greenhouse with little or no detriment. In many other respects one business can be made to serve the other. Under the tables or benches of the greenhouse on which the flowers are grown is a capital place for forcing rhubarb, an article everywhere commanding a ready sale at a high price. It requires but little knowledge or labor to produce this crop under the greenhouse benches. All that is necessary to do is to pack the large crowns or clumps of rhubarb as closely together as they will go, filling in the interstices with any good soil, beginning say the first week in January, February, and March to give a succession of crops. The roots should have been previously dug up and kept in some cool shed or cellar or in the open ground, provided they are so protected from frost that they can be dug up at any time in winter. Asparagus roots may be treated in the same way, but it is necessary that the asparagus and rhubarb roots should be of good size, such as when growing in the open ground would give strong and healthy shoots. Young or small plants of either would not answer. Mushrooms may also be grown under the benches of the greenhouse, the beds being prepared in the usual way; but the crop of these in inexperienced hands would not be likely to be so successful, nor would the sale, unless in very large cities, be so certain. The greenhouse too, as we have before stated in your columns, is quite as safe a place in which to raise all kinds of plants in use in the market garden as either the hot-bed or cold-frame. It can be easily made to serve this purpose if the demand for flowers is not yet enough to require the whole space. Vegetable plants can be raised with greater safety and with less care than is necessary in raising them in hot-beds or in frames, while the work is far more agreeable.

Three Crops in One Year.

S. C. wrote last December from Lexington, S. C., in the most enthusiastic manner respecting the great advantages offered by the climate of his state, and gives the following account of one of his experiments:

The first week in January last, I planted a small plot of ground in my garden with garden peas, which were ready for the table the 1st of May, and cleared away 20th of June, when I manured and turned under the same, planting northern corn in drills. The corn yielded splendidly, was matured, and cut the first week in September, with the beans which I planted in hills between the corn-rows, and also yielded well. On the 5th of Sept., I again covered it with manure and plowed under, when I sowed turnips in the drill. The turnips are still growing finely, and are now ready for the table. I have now sown barley in drills between the

turnip rows, which will be ripe by the middle of next June, when a crop of cow-peas or other variety of beans may be grown, to be followed by turnips again, or a similar crop.

The ground on which this experiment has been made has been in cultivation thirty-five years, and is better to-day than ever before,



THE JAPAN PRIMROSE.—(*Primula Japonica*.)

and I think there is little danger of over-cropping if a sufficiency of plant food is furnished to meet the wants of each successive crop. This is but a single experiment, but it may be successfully repeated every year, for this has not been the most favorable season for farming, and I cordially invite my northern friends to come and see for themselves. But few persons, even among those who have cultivated all their lives, have any idea what a good soil properly managed is capable of producing.

Primula Japonica—"Queen of Primroses."

The Japan Primrose we are obliged to regard as one of the greatest of recent horticultural humbugs—or rather let us say, not the plant, but the manner in which it was introduced. The plant taken upon its own merits is well enough, and a desirable addition to our hardy species, should it prove hardy, as we do not doubt it will. It is only when we compare the plant as it really is with the representations made of it both in descriptions and engravings in foreign journals and catalogues, that we are obliged to regard it as a fraud. An English journal goes on in this way: "Hail! Queen of the Primroses! for so its introducer designates the lovely flower we now figure, which is as

hardy as a peasant and as resplendent as a princess," which as a "gush" is about equal to anything to be found under "agriculture" in a New York weekly paper. Then we have in another journal with a picture to match, "A *Primula* a foot and a half high, bearing four or five separate whorls of flowers, each an inch in diameter, and of a splendid magenta color, and the plant moreover perfectly hardy—can anything be added to this to indicate its value?" To this last conundrum we can say yes—tell the truth about it, and say that while there are four or five whorls of flowers, they do not all open at the same time, and that the plant is about one fourth as floriferous as the pictures show, and as this description would imply. Our florists, with this as they do with other new things, have copied the foreign descriptions and engravings, and are not to be charged with misrepresenting a plant they had not yet had an opportunity of flowering. Last year English cultivators were bringing it into flower, and complaints began to appear in their horticultural journals that the plant was not like the pictures, and though the question was often asked if it had ever been known to produce more than one whorl of flowers at a time, we do not recollect to have seen an affirmative answer. We have inquired among those of our friends who flowered the Primrose last year, and their experience with our own this spring, with plants direct from Japan and from one of the best floral establishments in the country, make us conclude that if two or more whorls of flowers ever do open at once it is an unusual occurrence, and not the general habit of the plant. In our own plants by the time the first (lowest) whorl has faded, the flowers upon that next above are just beginning to open, and the seed vessels begin to enlarge so rapidly that if one did not wish seeds it would be best to remove them, as they detract from the beauty of the flowers on

the whorl above. The engraving gives a representation of our best plant, which to insure exactness and leave nothing to the imagination of the artist, was drawn with a camera lucida, which gives even more accuracy than a photograph. We do not know that any one has yet tried the Japan Primrose as an open border plant, but it is quite hardy in England, and as it has been kept until midwinter in a cold frame, we do not doubt that it will prove completely hardy. To sum up, this plant has been much over-praised, and been put upon the market at a high price with descriptions which to say the least were highly colored, it would be hardly polite to add with respect to distinguished horticulturists, "the same with intent to deceive," for we can understand that a florist if he be a F. H. S., or even writes an L. S. after his name, can look at a plant with double extra glorifying spectacles, especially if said plant is to bring him £1 1s. (the only fashionable price, which is quite different from the vulgar £1) a specimen. It is, however, a pretty plant, and when it finds its place in the border with other spring bloomers it will no doubt be quite popular. It is no more entitled to be called "Queen of Primroses" than *P. Cortusoides* and others, and as for a plant to force there is no need of it while we have our fine varieties of Chinese Primroses.

THE HOUSEHOLD.

(For other Household Items, see "Basket" pages.)

Farm Bath-Houses.

It must be confessed that the virtue of cleanliness is not sufficiently practiced by farmers or their families. Yet there is no class of people with whom the daily bath in summer time is a more

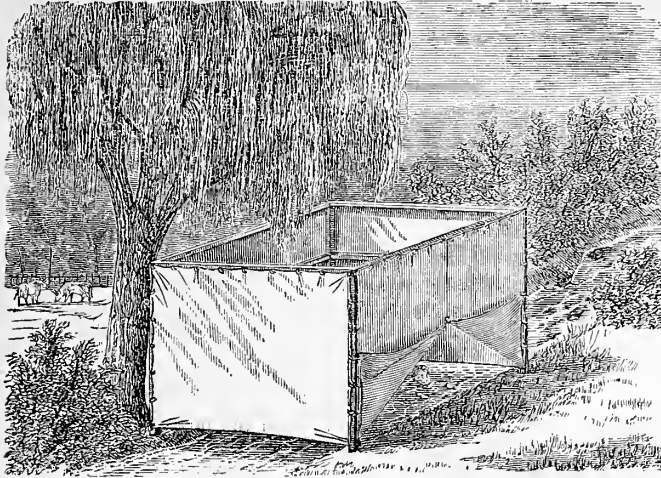

Fig. 1.—BATH-HOUSE.

imperative duty, and scarcely any to whom the duty can be made more easily practicable. Generally, farm houses have few conveniences for bathing indoors, but there is plenty of room out of doors for it. A bath-house will be found probably the most convenient arrangement. Where there is a small stream upon the farm, the plan shown in figures 1 and 2 may be adopted. We have made use of such a contrivance for the convenience of our own workmen, and they and their boys very gladly profited by it. It consists of six light poles or scantlings, pointed at one end, and set in the ground so as to cross the stream. Eight light cross-pieces are made with a wire hook at each end; the little brass hooks sold at the shops will answer the purpose. These hooks fit into small eye-screws inserted into the upright pieces, so that when the frame is put together a screen of double width brown sheeting may be hung around them. One side is made to open like a tent door, but may be closed by means of buttons and button-holes upon the ends of the strip of cloth. The screen incloses a space sufficiently large for a person to bathe in. A plank is placed across the stream upon which one may stand while dressing or undressing, and some hooks are fastened to one of the cross-pieces upon which to hang the clothes. Figure 1 shows

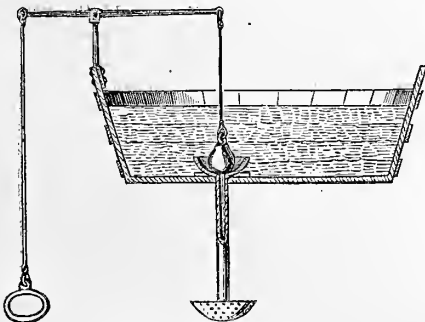

Fig. 4.—CUP VALVE.

the appearance of the screen. Figure 2 shows the inside with the arrangement of the frame. Where there is no stream upon the farm, a bath-house of similar construction might be set up in the backyard, in which a pail or tub of water might take the place of the stream.

A bath-house of somewhat more solid character is shown at figure 3. It is arranged for a shower-bath, and is built of light scantling and boards. A platform is made within upon which the bather

may stand, and from which the water may run into a drain and be carried away. A common tub is placed upon the roof, in the bottom of which the cup valve seen at figure 4, with the sprinkler and pipe, is fitted and cemented so as to be water-tight. The pipe may be of lead, and the valve cup and sprinkler of tin. The valve is a ball of lead, which is attached by a cord to a lever. From the other end of the lever a cord passes into the house within reach of the bather. It is not wise to use cold water from a well for a shower-bath, but only water which has been exposed to the air and sun until it has gained the same temperature as the atmosphere. Nor is it wise to allow a sudden shower to fall upon the head or shoulders and the back of the neck, as is frequently done. But when the water is falling the feet should be extended alternately into the stream, then each knee, then one side, afterwards the other, and by and by the stream may be received upon the shoulders and the back. In the mean time friction of the body should be kept up with a sponge or flesh brush, and the bath should not be long continued. The reaction from a bath thus taken is very pleasant, and after a weary day in the hay

or harvest field it brings a sensation of purity as well as of rest. It prevents that unwholesome, clammy perspiration which is always experienced when the skin is foul, and it produces grateful, restful sleep. Of course, no person who takes this necessary pains to be clean will sleep in his working underclothing; that would be greatly undoing what the bath has done. The working underclothing should hang all night in an airy place, and a proper night-dress should be worn in bed.

Home Topics.

BY FAITH ROCHESTER.

"GOOD LIVING."—There is a difference of opinion as to what constitutes good living, and I shall not undertake to settle any disputes *de gustibus*. The Esquimaux Indian may eat his delicious tallow candle and drink his whale oil, and call both good; the Iclander may delight in his rancid butter; and others may swallow sour-kraut with unmoved face, or cook and eat their wild game after it has become unbearable to the sense of smell—I shall not say that these things are not pleasant to the taste of those who eat them—but "deliver me." Science may put in a modest word—and Science, you observe, grows more and more modest in her *dictums*—concerning the *healthfulness* of various articles of diet. She may venture to ask us whether anything *eau really* be good living which gives only a momentary pleasure to the nerves of taste, while it destroys the comfort of the body and undermines the health.

Nothing can be called "good living" by a person who has not the least relish for it, and it is doubtful whether anything is really good for a person which is eaten with positive disrelish. So I think it very unwise to oblige children to eat anything against which their stomachs rebel, because they have taken it upon their plates or because we think it is good for them. I know the dilemma very well, and am sometimes obliged to decide that it shall be that or nothing farther at that meal, when I perceive that the child refuses its plain fare, which was palatable only a moment before, as soon as it catches sight of something more dainty.

But it is very certain that the appetite changes with habit, and that it is capable of cultivation. Children who are brought up to eat vegetables saturated with butter and highly seasoned with pepper and salt, so that very little, if any, of the natural flavor of the vegetable is retained, can not

believe that they could relish the same things simply well-cooked and only very moderately seasoned. They even prefer rancid butter on their squash or turnip to no butter at all, and then if there is any disagreeable flavor, or combination of flavors, they drown it out with pepper.

It sometimes happens that a person who has learned how much depends upon care in the preparation of articles of food will sit down to a table where there is a variety of dishes which he would like if suitably cooked, and not find a single thing that he can relish. The potatoes are soggy, or flavored with the decay which one or more bad ones had imparted to the kettleful, or they are served swimming in hog's fat or melted butter. The other vegetables are all tainted with poor butter, or made hot with pepper or over-salted. The eggs are cooked so much as to be very hard of

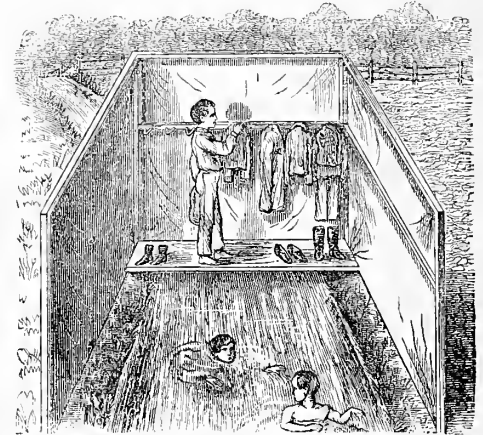

Fig. 2.—INTERIOR OF BATH-HOUSE.

digestion. The meat is not "just done," or is too greasy. The prepared fruit has been deprived of its own finest flavor, and the fault has not been remedied by the excess of sugar in its seasoning. The yeast bread is sour and hard, and the hot biscuit is green with soda. Even the graham gem gives out an odor of soda as you break it open, and the oatmeal mush is so salt that you can not like it. Even the milk tastes of the cellar. But there is cake and there is pie, and you are supposed to be able to fall back upon these with satisfaction; but it is not at all likely that a housekeeper who spoils all her plain cookery by carelessness or ignorance will give you very satisfactory and wholesome pie or cake. Anyhow, a well-educated stomach does not wish to depend upon pie and cake—it wants good nutritious and appetizing food.

A MAN'S REPORT OF A GOOD COOK.—A gentleman who had just returned from a business trip to Missouri said in my hearing that Mrs. — was the "best cook in Missouri." I took an early opportunity to ask him to tell me wherein the excellence of her cooking lay.

"Well, in the first place," said he, laughing, "her table-cloth is always nice and clean. Then her dishes are always so bright, and everything she puts on the table comes on in good shape, somehow."

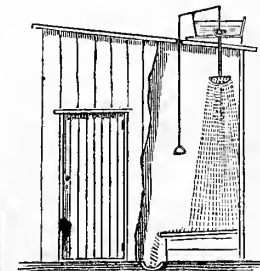

Fig. 3.—SHOWER-BATH.

"Go on," I said, "All this gives you a good appetite for the food itself."

"Yes," he replied. "I always feel as though the victuals would be good as soon as I see her table, and they are good. She gives us just the same things that we get at other places, and they seem to be cooked plainly and not much seasoned, but they are always cooked *just right*—nothing burned and nothing half raw. And they all *look so nice!*"

"You see, Faith," good-naturedly interposed this gentleman's wife, to whose skirts two small children were at that moment clinging—"You see,

Mrs. S. has not a single child to soil her table-cloth or hinder her washing it, or to demand immediate attention at any critical moment during her cooking. She does all of her work herself, and does it nicely—not much as most hired girls would do it."

Yes, I *did* see, and so did the gentleman who gave me his idea of a good cook; and we all agreed that he was probably right in his estimate of the Missouri housekeeper, while we realized that these little things, which are so important after all, are not so easy for every housekeeper to secure as many might suppose at first thought. Yet these things, carefulness in details, cleanliness, and order, are always worth striving for.

NIGHT VISITS.—Mother, you had better say "no" decidedly when your little girl asks if she may go to stay all night with Mollie or Katie, or Bell; and never consent to your little boy's request to be allowed to spend the night with one of his school-mates. Tell them that the night was made for sleep, and not for long talks while lying in bed. Explain to them what a blessed thing sleep is, "tired Nature's sweet restorer," and what a good thing it is to get a habit of going to bed and to sleep regularly at an early hour, so that body and brain may both get plenty of quiet rest, so necessary for their growth and healthful activity. Then give them clean, well-aired beds, in rooms where there is plenty of pure air all night long, and let them sleep until they wake themselves in the morning.

EARLY RISING.—The old couplet—

"Early to bed and early to rise
Makes a man healthy, wealthy, and wise—"

seems to be falling into contempt. The cause of this may be the fact that too many have insisted only upon early rising without paying any attention to the hour of retiring. It has been discovered that most of us who work with our hands or our brains take too little sleep, and so grow nervous and diseased. So late rising is recommended, while little protest is made against the late hours of bedtime in which such persons usually indulge. This is beginning a reform at the wrong end.

It is better to begin at this end, though, than not to begin at all upon a reform. Lack of sleep is one of our most crying physical sins. We know how cross and unreasonable small children become when they lose their regular daily nap. Children of a larger growth are affected in the same way, though they, perhaps, only "fret inwardly." The scolding and fault-finding in families would grow beautifully less if all the family members had plenty of healthful rest for body and brain, such as natural sleep affords. The demand for stimulants of all kinds would also grow less.

It is a very cruel thing to wake a child from its morning sleep. If it sleeps late, it is probably because it goes to bed late—unless it sleeps from very stupor, because its bedroom is so badly ventilated. If the child comes late to breakfast, or otherwise causes annoyance, let it feel some natural inconvenience or discomfort itself—a cold breakfast perhaps, or the loss of papa's morning society before business claims him for the day. It will soon learn that "early to bed" is the natural forerunner of "early to rise."

It is only fair that the older members of the family should grow quiet as the children's bedtime approaches, so that the little ones will not feel that they are making a great sacrifice in leaving the family circle.

I do not know whether all children need the same amount of sleep. Certainly the youngest ones require most. Our boy of seven thrives best upon ten hours sleep out of each twenty-four; and I see that other children of that age require the same amount. The younger children take more when they take what they seem to need, but all are in the habit of sitting down with the family to a quarter-past-six breakfast, as a general rule.

HANGING LAMPS.—"Somebody keeps getting in my light." "Take care! you'll have that lamp tipped over!" Such expressions are very common where the "evening lamp" stands upon a table

around which the family gather for reading and amusement.

I have lately been visiting in a family where no such expressions are heard, where all, sitting in any part of the room, enjoy a full flood of light. This family could not be induced to part with their hanging lamp. It gives them a feeling of safety in the midst of fun and frolic, and it is always an ornament to the room. Some rooms are too low for hanging lamps, but wall lamps might often be used to advantage in such rooms. The room of which I write is twelve feet high, but the same lamp could be used in a lower room without inconvenience by using a shorter chain for its suspension. It has three lamps, but seldom are they all lighted at once. The frame-work is of bronze, and the glass oil fountains are taken down upon the table for trimming and filling. This lamp cost ten dollars, but cheaper ones can be obtained—those with two burners or with only one, of various patterns.

THE BROKEN LAMP.—If the fountain (or the glass globe that holds the oil) has only come loose from the standard, this is very easily remedied by the use of plaster of Paris. Mix a small quantity with water, make it as thick as cream, and fill it in between the glass of the fountain and the hollow in the top of the standard as quickly as possible. As it sets immediately, everything must be done with promptness. If the fountain is broken in pieces, and there is a whole bronze or brass standard remaining, it will pay to purchase a new fountain and set it upon the old standard in the manner described above. The brass top can be fastened on in the same way.

CLEANING NEW IRON-WARE.—I do not remember to have seen directions anywhere for preparing new cast-iron utensils for service in cooking. I know I had a deal of trouble with my first stove furniture, and whenever I have anything of the kind to deal with now I wonder if there is not some better way than I have learned. I have just been tackling a new set of iron gem-pans. I filled them with ashes and water and left them standing during the forenoon. I heated them on the stove before emptying them, and then gave them a good washing and rinsing. I think they will do for use to-morrow morning. I usually scour new kettles with ashes, then rub them over with a little grease, and wash them well with suds. To-day a lady told me that it was a good way to wash new irons with sour milk. I had no sour milk to use, but I do not see the philosophy of it. It is not rust with which we have to deal in cleaning new iron, but a fine sand, used in the casting.

SALT MACKEREL is almost always too salt when served at table. So I think that Prof. Blot is right in advising a twenty-four-hours soaking, the water to be changed three times. Then he would have you broil the fish over hot coals. It may be served with a little cream, or dry if preferred.

A lady cooks mackerel for dinner in the following acceptable manner: Wash it thoroughly and soak it over-night. In the morning change it to fresh water, and two hours before dinner put it in enough sweet skimmed milk to cover it. Then put it in cold water to cook, never letting it more than simmer in the gentlest manner, but keeping it in water at the boiling point for about twenty minutes. Take it carefully from the boiling water upon an unrusty baking tin, cover with sweet cream, and set in the oven for a few minutes before serving. But the next biscuit you bake in that tin may taste of mackerel unless you are very careful in washing it.

CRACKER DESSERT.—I do not remember to have seen in print directions for making a quick and cheap and pretty and palatable dessert which I learned how to make many years ago. Choose whole soda crackers, and lay each one upon a separate small plate. Pour upon it enough boiling water to soak it well, and leave none upon the plate; cover with a dressing of good sweetened cream with a spoonful of jelly in the center if you choose, or dip upon it a portion of nice fruit, canned, stewed, or fresh, as is convenient.

RECIPE FOR INK.—I thought I would not write another word with this detestable "writing fluid," but wait until I had made myself a whole gallon of good black ink. But it occurs to me that some one else may also be suffering for good black ink, and I might tell them how to get a gallon of it for a dime. I have made it several times, and always with success, and the materials have never cost over ten cents. The actual cost is probably less, but your druggist may not be willing to put up any "prescription" for even so small a sum. Ask him for 1 oz. extract of logwood, 48 grains bichromate of potash, 24 grains prussiate of potash. Heat a gallon of soft water to boiling, add the logwood and boil five minutes, then add the other materials and boil all together two minutes.

Wet Boots.—A friend writes from Europe: What an amount of discomfort wet boots entail, to be sure; and how well we all recall the fretful efforts we have now and then made to draw on a pair of hard-baked ones which were put by the fire over-night to dry. Damp and adhesive within, they are without stiff and unyielding as horn. Once on, they are a sort of modern stocks, destructive of all comfort, and entirely demoralizing to the temper. The following simple device will rob the cold, wet barn-yard of a slushy winter or spring evening of half its promise of discomfort for the next morning: When the boots are taken off, fill them quite full with dry oats. This grain has a great fondness for damp, and will rapidly absorb the last vestige of it from the wet leather. As it takes up the moisture it swells and fills the boot with a tightly fitting last, keeping its form good, and drying the leather without hardening it. In the morning, shake out the oats and hang them in a bag near the fire to dry, ready for the next wet night, draw on the boots, and go happily about the day's work. This simple recipe, tender-footed reader, will save you much discomfort, and will make you a tender-hearted reader as you sit in your soft foot gear looking over your *Agriculturist* as you wait for breakfast to be made ready.

Wants to Suit George.—A lady asks for help. Who will respond? She says: "I should like to ask the best way to make a nice, light, boiled, cheap pudding—one that we can afford to eat as often as we want it. I have tried a number, but have failed to suit George. Will some of the lady readers please help me out? Also I should be pleased to get a recipe for nice sponge cake, and one for catsup that will keep for a year."

Washing Milk Dishes.—Last fall there was an item on washing milk dishes. One of our housekeepers thinks her way is better. She says: "First wash the pans in lukewarm water which, without causing the cheesy element in the milk to adhere, does entirely dissolve the cream. Follow with clear, hot water; then scald the pans and wipe them, after which give them a 'sun bath,' or in the cool season place by the hot stove until sure there is no moisture about the seams. I use no soap, but my pans are always sweet and smooth."

Tea Cakes.—By Mississippi.—Five tea-cups of flour, two and a half of sugar, half a cup of butter, four eggs, sour cream enough to make a soft dough, and one tea-spoonful of soda. Roll thin, cut into shapes, and bake in a tolerably quick stove.

Baked Apple Dumplings.—By Mississippi.—Roll out some dough thicker than pie-crust, and inclose a handful of sliced ripe apples well covered with sugar and butter. Bring the edges together as in any other dumplings. When as many are made as are desired, place them side by side in a pudding pan, spread butter and sugar over them, and pour boiling water to about half cover the dumplings. Put them in the stove and cook moderately fast until they are nicely browned. The butter, sugar, and water make a nice sauce, which can be enriched with more butter, and flavored with nutmeg if desired.

BOYS & GIRLS' COLUMNS.

A Street Toy—The Magic Tape.

One who goes about the streets of New York, whether he is only a visitor or lives in the city, is much amused at the variety of toys offered for sale by the street vendors. Some have a single toy, the whole stock of which they carry in their hands and coat pockets or in a bag; others have several, which they display upon a stand that can be carried from place to place. Very often the fashion will suddenly change, and a particular toy will disappear and another take its place. One of the new toys of this kind is one called the "magic tape." Not long ago there were men and boys crying out, "Here you are, only ten cents—the magic tape—here you are." Of course we always stop to look at these street things, as they are often quite amusing. In this case the man had what appeared to be a small square stick with a slit in two opposite sides, and through this slit there ran a piece of tape with a knot at each end to keep it from running through. There did not seem to be anything very strange in a piece of common red tape hanging from a slit in a square stick—but the man took hold of the knot upon the opposite side and pulled it through, and behold it came out black! Some of these square sticks had a tape at each end, as in figure 1, and each one by being pulled through showed two different colors. What could make the tape change color so quickly by just drawing it through a slit? Being used to such tricks, we saw at once how it was done, and by showing you the inside of the affair in figure 2 you will readily see the way of it. The square stick is made of a piece of pasteboard, cut part way through so that it will bend easily and neatly. The tape, instead of going directly through the

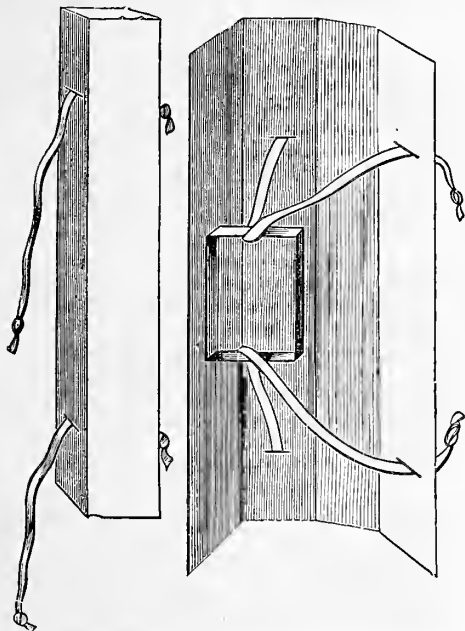

Fig. 1.—OUTSIDE.

Fig. 2.—INSIDE.

slits in the side, as it appears to, is much longer than it looks to be, and is passed around a loop of string or wire fastened inside of the case. If one half of the tape be white and the other half blackened with ink, it will be seen that when one knot is pulled the white will show, and when the other is pulled the red will appear. Like all tricks of this kind, this is easy enough when you know how.

He has a Strong Passion.

One of our boys says in a letter that he has "a strong passion for writing," and sends us an article hoping that we will publish it. Our declining to print the article will, of course, disappoint the writer, but it is better to do that than to publish an article that would only interest him and perhaps his family. We think that some journals for young people have done mischief by printing articles by children and giving the names of the writers. It directs a child's attention from proper studies, and in many cases it encourages a harmful vanity by printing children's names. While we like to have the boys and girls write to us and tell us what they are doing, and ask us questions about things, we rarely print their articles, and almost never, except in awards of prizes, give their names. Now, we would not discourage any boy who wishes to become a writer; indeed, if he is naturally

but in this direction, it would not be possible to discourage him. But boys with a "strong passion" in this way should remember that they may indulge it to the loss of something useful. We pity the youngster who has taken it into his head that he will get his living with the pen. Some of the very few successful writers are held up as examples, but very few know of the thousands of miserable failures made by men who try to write for a livelihood. So we say to this and all other boys with "a strong passion for writing," first learn some useful occupation by which you can always be sure of a living, then if you have a marked talent for writing it will find a chance for exercise. But one can not write without education and experience. And you can no more draw water from an empty cistern than write anything worth reading from a brain that is not well stored with knowledge gained from observation and study. Do not indulge in this strong passion, or any other, until you have a thorough English education at least, and we would especially advise the boy in question to give his attention to spelling and grammar. A passion for writing is not half so desirable as the ability to write well.

A Beautiful Charity.

As we passed out of the depot in Boston, two or three years ago, we saw by a sign that "Flowers for the sick poor may be left at — chapel, on Tuesdays, Thursdays, and Saturdays." We stopped and looked at this sign and thought, "Well, this is a 'Boston notion,' and a blessed one it is." Upon inquiry, we found that certain ladies met at a chapel which was handy to the many business men who have fine places in the vicinity of Boston, and that these gentlemen brought in flowers on certain days, and the ladies made them up into bouquets and distributed them among the sick in the poorer parts of the city, and if there were any left after all the invalids were supplied, they were taken to the women who work all day in crowded factories and shops. We say this is a beautiful charity. You who have never lived, much less been sick, in a house in a narrow street, where the only view is another house upon the other side of the street, can not imagine what a precious gift a handful of even common flowers can be. How many a poor boy and girl have been made happy, and the hours of their sickness made less dreary by having some bright and beautiful flowers to tell them of the world without! and more than this, to tell them that there are kind and loving hearts which could devise and carry out such a blessed plan! A good thing is sure to be imitated, and last summer some ladies in New York did the same kind office for the many sick in the public hospitals. Each one of you boys and girls can be a society of one to do some good in this way. People make a great mistake in sending the sick things to eat. It is done in kindness, but it is in most cases mistaken kindness. The sight is often the only sense that can be gratified without injury, and flowers are almost always welcome to the sick. When you know that one is ill—and you need not care if it is a personal acquaintance or not, only know that some one needs them—you can often do much good by quietly leaving a bunch of flowers at the house. Wild flowers are often quite as pleasing as any. When you know that the person is very ill, avoid all strongly perfumed flowers, as these are sometimes oppressive even to those who like them when they are well. It is not the value of a gift that is appreciated, it is the thoughtfulness that sends a gift at all; and the merest child in this way can often bring light and cheerfulness into the chamber of sickness. Think of this, and when the opportunity offers, act.

Games for Picnics.

Unless there is some lively person at a picnic who knows all sorts of amusing games, and will "keep things agoing," the affair is very apt to prove a dull one. There are a plenty of games for in-doors, but most of these are not suited as out-door amusement. We know that fox and geese and such games, which are too boisterous for the parlor, are just the things for the open air, but these lively games are so few that it is a pity we had not more of them. We heard the other day of a game which boys can play for the amusement of the girls, as it is a little too rough for them to engage in it. In fact, it is a trick rather than a game, and there is not much fun about it if all know it. It is called the "Prussian Drill." The boys are the soldiers, and are drawn up on the grass to be drilled in the presence of the young ladies. The captain takes his place in front and the sergeant is in his place on the right of the company; these two only should know the trick. The captain should be quite pompous, and tell his troops to follow the motions of the sergeant. He begins by a few simple movements, as "heads up," "eyes right," "front," "eyes left," etc. Then the order is given "ground right knees," and all follow the sergeant in kneeling on the

right knee. "Right hands forward," "left hands backward," brings the arms out to front and rear. Then the captain gives the order to "fire," at which the sergeant gives the boy next to him a push, he tumbles against the next, and all, being in this helpless position, go over like a row of bricks, to the great amusement of the spectators. If you know that there is any "touchy" boy in the party, who can not get a harmless tumble upon the grass without being offended, you had better not try this trick; but with boys who like fun, even if it is at their own expense, it is very amusing. Who will tell us some good games for picnics that both boys and girls can take a part in—not the old, old ones, but some that have come up of late years?

About Old Fireplaces.

In these days of stoves there are but few fireplaces compared to what there were fifty or more years ago, and those that we do see are common affairs made to simply burn wood. In olden times, those who built houses took much more pains with fireplaces than we see given to them at present. They were, in the houses of the wealthy, made very showy and expensive. The mantel-piece was often curiously carved and costly, and the opening of the fireplace surrounded by a frame of brass, which, with the large brass andirons, was kept as bright as could be, and as the two reflected the light of the fire it made the fireplace look very bright and cheerful. In houses a hundred years old or more there can still be found some of these quaint fireplaces, which were in their day thought very fine. In the better houses of that time it was a very common custom to have all around the opening of the fireplace a row of ornamental tiles. These were imported from Holland for the purpose, and were known as Dutch tiles. They were, however, used by others besides the Dutch settlers, for they were the fashion in New England where there were no Dutch. The tiles were six or eight inches square, of a white glazed earthenware such as table dishes are made of, and were ornamented with figures of various kinds. There was usually a border of ornamental work, and in the middle



AN OLD DUTCH TILE.

a figure-piece of some kind, all done in black, blue, or other color. Sometimes these tiles had the pictures so arranged one after another as to tell a Scripture or some other story; sometimes they had no relation to one another, and they were often quite funny. The writer recollects, when a child—oh! so long ago!—of sitting before grandmother's fireplace and trying to guess what these tiles were trying to tell. But all are gone now—house, tiles, grandmother, and all but the memory of the child sitting and wondering at the tiles. You may suppose that we were pleased to see a drawing which one of our artists made of one of these tiles which he came across in a collection of curiosities. It brought back the things of long ago; and we thought that you would like to see the picture of this tile and know about this odd custom of our grandparents and great-grandparents for many generations back.

A Neat Puzzle.—We have not had any puzzles lately, and this, which is a very simple one when you know how it is done, is really a puzzle to those who have never seen it. The puzzle is to take a piece of stiff paper, card-board, or leather, five inches long and three inches wide, and so cut the piece so that you can pass through it. This column that you are reading is just two and a half inches wide, so that will help you to form an idea of the size of the piece if you have not a measuring rule at hand. We will let you puzzle over this until next month. It is easily done if you know how.

Aunt Sue's Puzzle-Box.

HIDDEN NAMES OF ANCIENT GRECIAN DEITIES.

1. How diligent the ant is.
2. I have only been once to New York.
3. This, sir, is one of your manufacture.
4. Was Oliver there when you left?
5. Before you go I should like you to take a nap, Anna.
6. I wish you would go to the shop, Sam, and bring me some wire.

PUZZLE.

To make a man's name, take one-third of the sun, one-quarter of a band, one half of a mule, one-fifth of the earth, and one-quarter of a colt.

F. SCHWANMAN.

NUMERICAL ENIGMAS.

1. I am composed of twenty-six letters.
My 4, 24, 17, 13 is a coin.
My 19, 11, 20 is a stamp.
My 6, 18, 21, 14, 3, 9 is a marsh.
My 16, 22, 21, 26 is to repair.
My 12, 25, 1 is a quadruped.
My 2, 15, 7, 8, 21, 20 is to damage.
My 10, 5, 23, 13 is to carry.
My whole is a motto of one of the United States. **ELKIM.**
2. I am composed of twenty-six letters.
My 9, 1, 4, 16 is a mineral.
My 19, 22, 24, 26, 10 is to perch.
My 2, 6, 12, 14 is endless.
My 5, 15, 20, 25 is a young lady.
My 17, 13, 2, 19, 6, 7, 8 is a fish.
My 26, 10, 11, 3, 5, is an article of furniture.
My 24, 23, 18, 21 often causes terror to the superstitious.
My whole is a well-known proverb. **KATE McCUNE.**

SQUARE WORDS.

1. Square the word "CORD."
2. Square the word "DISH."

WILLIE H. K.

PI.

Tantsone progdpin liwl rewa yaaw sotsen.

CHARLEY SMITH.

CONCEALED SQUARE-WORD.

This is such a sharp knife, it cut me as I ate my breakfast. Is it safe, do you think, to have such a sharp thing about?

TRANSPOSITIONS.

Fill the blanks with the same words transposed. (e. g.—The — was very —. The peach was very cheap.)

1. The — has just crossed the —.
2. "Hurry and get up —," said one of the —.
3. I shall — the proposition to take a —.
4. The — ran off with her box of —.
5. Some people who have plenty of — are very —.
6. He — the food at — periods.
7. The Mormon — entertain different — of polygamy.

ALPHABETICAL ARITHMETIC.

PERISH) T O P E R S E Y E S (Y H Y I O
I E P O S Y

C S C T E
P E R I S H

H S T T T Y
I E P O S Y

Y E C O T S E
Y I I R E S I

H I I E S Y S
H C T R T S O

HE Y Y H R M. L. A.

CROSS-WORD.

- My first is in false but not in true.
My next is in boil but not in stew.
My third is in you but not in me.
My fourth is in river but not in sea.
My fifth is in water but not in air.
My sixth is in lion but not in bear.

My seventh is in thick but not in thin.
My eighth is in needle but not in pin.
My whole a lovely place I ween,
In Italy it may be seen. **J. M. IRVIN.**

ANSWERS TO PUZZLES IN THE APRIL NUMBER.

NUMERICAL ENIGMA.—Robin redbreast.
HIDDEN COUNTIES.—1. Ford. 2. Scott. 3. Pope. 4. Sallie. 5. Stark. 6. Hardin. 7. Gallatin.

PI.—If you wish to be happy yourself try to make others happy.

East produces a sticky substance upon its stem and leaves which, if swallowed or smoked, produces a remarkable kind of intoxication. A person under its influence sees wonderful visions and is for awhile in a most happy state. One of the names for this drug is hashish or hasheesh. About 800 years ago there was in Persia, Syria, and Arabia a remarkable secret society or order, happily long ago broken up, as it was kept up for the most wicked purposes. Every member of it had to swear perfect obedience to his superiors, and if told to kill another, or to kill himself, he was obliged to do it. A great many secret murders, even of sultans and other officers, were committed by the members of this wicked crew. In order to get those who joined this society to take the horrid oaths that bound them, they were made drunk with hashish; they were given to "hashishin," as the using of hashish was called, and as the hashishins often killed people, the name was also used for murderers. It is by this round-about way we get our English word assassin. **THE DOCTOR.**



SUNRISE.

Goats.—An Ohio boy, ten years old, having seen our account of goats, has written to know if we can get him a pair. We are sorry to tell Master Ira that we can not do this, for two reasons. In the first place, we do not make purchases of this kind for any one. We have not the time. If we wished a pair of goats ourselves we should pay a person to go and hunt them up for us. In the second place, we do not think that youngsters of ten are the best judges of what they ought to have, and if we knew where to get goats we should not help our young friend to introduce the troublesome things upon his father's farm. We have no doubt that a pair of goats would in one season do damage to the amount of the value of a good horse. Master Ira says he has already a colt and a yoke of steers, which we think ought to satisfy him for awhile.

An Apology is needed to those boys and girls who last month looked for the apple that the boy, in the picture called "Making an Acquaintance," had brought to the calf. We looked at the drawing hurriedly before writing about it, and were quite sure there was an apple in the boy's hand. Perhaps the artist altered his mind after we saw a mistake of ours—but, at any rate, that boy might, could, or should have had an apple in his hand with which to make friends with the little calf.

Sunrise.

Here is a picture for little girls—and by the way we do not know of any reason why little boys, and big ones, too, may not like it. The artist had seen the sun rise bright and clear, driving away the darkness and making all the world look pleasant, and naturally enough when he saw this little girl rise up from her sleep he thought of the sun, and he called his picture "Sunrise," for she in the little world of the family brought brightness, and seemed, as many little girls are, the light of the house. We, unless we are all, all of us rise every morning as regularly as the sun. The sun is always bright and shining somewhere, though clouds may prevent us from enjoying his warm rays; yet when there are the thickest clouds he gives some light through them. But do our little girls always rise with brightness? They are sometimes dim; the clouds do not hide their light, the darkness is in themselves. No doubt this little girl in the picture, who begins the day aright, will keep pleasant and sunshiny all the day long. It is a good thing for all of us to start right in the morning, and let our presence be to our friends as welcome as the sunshine. This picture is from a beautiful bas-relief, but we shall have to tell what that is another time.

BLANKS.—1. Write, rite. 2. Cypress, Cyprus. 3. Pare, pair. 4. Principal, principle. 5. Air, heir. 6. Bawl, ball.

DIAMOND PUZZLE.— M
C A T
R A C E S
M A C B E T H
D R E G S
A T E
H

Cross-Word.—Constantinople.

ALPHABETICAL ARITHMETIC.—
723)4861059(6723 (Key: Black Horse.)

Thanks, for letters, puzzles, etc., to E. J. K., Cadoc C., Clarkson F., Perry A. M., J. Plumer, Fannie L., and Gussie D. L. V.

All communications for the Puzzle-Box should be sent to AUNT SUE, P. O. Box 111, BROOKLYN, N. Y.

A Curious Origin of an English Word.

When answering the question about currants last month, I happened to think of a word that has a curious origin. In order to tell you about this I must state that the hemp which grows in India and other parts of the

Life Insurance.

"What is he worth?" is the question by the answer to which, in this somewhat mercenary world of ours, a man's standing, reputation, ability—himself, in short—is measured. Whether the gauge be a true or false one, whether by its application genuine worth be often made of no esteem, and tinselled vice be adjudged virtue, still the fact remains; this is the popular standard of man's true merit; and we all, to a greater or less extent, in spite of our counter-protestations, accept and are governed by it. Even while on our lips may be the trite quotation, "Worth makes the man, the want of it the fellow," we turn contemptuously away from the "man" because he is poor, to effusively greet the "fellow," because he is rich! We note the fact, and pass it with the commentary, "Such is life."

But, apart from all this, every man, every working man, in whatever department of labor, has a money value. He can be ciphered up and reduced to dollars, and that without reference to the money he has accumulated. The commonest laborer, although he own not a foot of real estate, or an article of personal property, save such as are indispensable to himself or family, has, nevertheless, a money value; he is worth something in currency. He is a capitalist; he has that in him which yields a revenue. His muscle and the skill which directs it are stock. The pay which he receives at stated times is the interest on his investment. Suppose his wages to be \$1.50 per day; then, making no allowance for loss of time by sickness or other disability, he receives annually, as interest upon his capital, \$469.50. Taking the average rate of interest as eight per cent, this income represents a capital of \$5,868.75. The actual worth of this capital—its actual amount, if you please—is reduced by the liability of its possessor to disease or accident. But, these apart, the money value of the day-laborer, working at the rate named, may be set down at very nearly \$6,000. This represents what he is worth in money to himself and those dependent upon him for support.

The mechanic, whose skill and labor yield a return twice as large as that of the day-laborer, has a capital twice as large—is worth twice as much.

The money value of the active professional man is greater than that of the mechanic, because he has more capital invested, and his labor brings him more money. As the marketable value of the skill and labor employed in any of the various avocations of life increases, so does the money worth of the worker in that avocation increase. And, generally, for each additional \$1,000 of income earned by a man for his family, his money value is increased by \$12,500.

This value should be protected by insurance, as much as any other value. The man who fails to insure his goods in store gets little credit, and finds no sympathy when calamity overtakes him. But what creditor has such demands as wife and children? Who have bestowed more? Who have exacted less?

The duty of providing the family against the contingencies of his early death is one which no husband or father can honestly neglect. And among all the places where that duty can safely and satisfactorily be performed, none is more secure, more liberal, more desirable than with the United States Life Insurance Company, of this city. Its solvency is undoubted; its record stainless; and its present management all that could be desired.

Boys We desire to employ for the next 2 years a boy or girl from 14 to 18 years of age in every township in the U. S., to sell our popular books.

Girls

Address J. H. JEWETT & CO., Norwich, Conn.

SOMETHING NEW in relation to Boys' Boarding School, 8th year. No extras. All books furnished free to scholars. Catalogues free. Address HIRAM H. POST, Prin., Sing Sing, N. Y.

KEY-TO-THAT-AND-NO-WEAR
WILL WIND ANY WATCH
FOR SALE BY WATCHMAKERS BY MAIL 50c. J. S. BIRCH 3714 1/2 10th St. N. Y.

\$200 Piano. Circulars free. U. S. Piano Co. 810 B'dway, N. Y.

Highest Premium (Medal) Awarded by AMERICAN INSTITUTE.

ASBESTOS ROOFING

The **ASBESTOS ROOFING** is adapted for steep or flat roofs in all climates, and can be cheaply transported and easily applied. **ASBESTOS ROOF COATING**, for restoring and preserving roofs. **ASBESTOS PAINT**, for Roofs, and all outside work. **ASBESTOS CEMENT**, for repairing leaks of all kinds on Roofs. **ASBESTOS BOILER FELTING**, **ASBESTOS BOARD** and **PAPER**, **SHEATHING FELTS**, etc. These materials are prepared ready for use, and are put up for shipment to all parts of the world. Send for descriptive Pamphlets, Price Lists, etc. **LIBERAL INDUCEMENTS TO GENERAL MERCHANTS AND DEALERS.**

Patentee and Sole Manufacturer, H. W. JOHNS, 87 Maiden Lane, N. Y.
ESTABLISHED 1858.

(CIRCULAR.)

Consumers Importing Tea Co.,
No. 8 Church Street,
P. O. Box 5,509. New York City.

This is a combination of capitalists to supply the consumers of Teas throughout the United States on the mutual principle.

We have experienced agents in all the best districts of China and Japan to select Teas especially for our trade.

We expect every consumer of Teas to render us all the assistance they can in carrying out our enterprise, as we make a specialty of **SUPPLYING CONSUMERS ONLY** (and allow no middlemen to make any profit on our importations), which will enable us to supply them with Teas at prices lower than have ever been known, and of those fine qualities that seldom reach the interior, being sold only in the large cities and among the very wealthy.

Hoping the consumer will take an interest in our enterprise, and send at once for a circular with full explanations of how to proceed to obtain our goods, we remain,

Most respectfully yours,

Consumers Importing Tea Co.,
No. 8 Church Street,
P. O. Box 5,509. New York City.

Entered, according to Act of Congress, in January, 1874, by the Consumers Importing Tea Co., in the Office of the Librarian of Congress, Washington, D. C.

HOPE SEAT SPRING,

One of the most useful inventions of the age. It is adapted for any kind of Wagon. It is **cheap**, it is **effective**, it is **durable**. No farmer should be without a pair. Those using them say it is the **best** and **easiest** spring ever made. Send for circular.

BENJ. F. WELLS, Sole Agent,
47 Dey St., New York.



Rifles, Shot Guns, Revolvers, Pistols, Ammunition, Fishing Tackle, etc. For Price-list, see page 157, April No. *Am. Agriculturist*, or address, with stamp,
GREAT WESTERN GUN WORKS,
285 Liberty St., Pittsburgh, Pa.

A SILVER TIP

Adds Five Cents
TO THE COST OF A SHOE,
and \$1 to its value.

**Self-Propel-
For Cripples**

Can be easily in or out doors, using the use of State your weight for illustrated different styles and



Please mention this paper.

**ling Chairs
and Invalids**

propelled, either by any one hands, and send stamp catalogue of different styles.

S. A. SMITH,
No. 32 Platt St.,
N. Y. City.

Eclipse Portable

Best, latest improved **ENGINE**. Portable or stationary use. A grand success! Guaranteed. Send for Catalogue. **FIRCK & CO.**, Steam Engine and Boiler Works, Waynesboro', Franklin Co., Pa.

The Turtle

Is the only Harrow made in the United States entirely of wrought iron and hard steel, and is the most indestructible tool in market. Nothing can equal it as a pulverizer, a weeder, a sod-cutter, or a seeder. It is absolutely self-clearing, self-sharpening, and is altogether the most desirable Agricultural Implement ever offered.

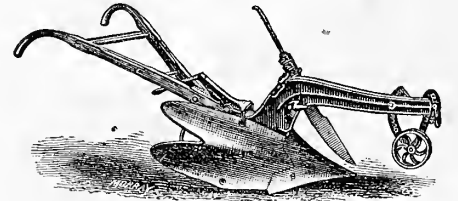

Also, the best and latest improved Swivel Plow for LEVEL LAND or Side-Hill. Has been victorious in all field trials, taking first premiums in every case as the lightest in draft and for the **BEST WORK**, in competition with leading flat land as well as other swivel plows.

For circulars and full particulars of the above, or for any other really first-class farm tools, address

CARR & HOBSON,
56 Beckman St., New York.

GEO. A. PRINCE & CO.

ORGANS & MELODEONS.

The Oldest, Largest and Most Perfect Manufactory in the United States.

53,000

Now in use.

No other Musical Instrument ever obtained the same popularity.

Send for Price-Lists.
Address

BUFFALO, N. Y.

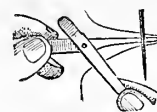

EVERY LADY that uses a Sewing Machine needs the

MAGIC THREADER

By mail, 25 cts.; with 1/2 doz. standard needles, 50 cts. Full description in *Am. Agriculturist* for April, page 153. In ordering, give name of Machine. Agents wanted everywhere. **The ARGO MFG. Co.**, Box 342, Springfield, Mass. Please mention *Am. Agriculturist*.

IT IS NOT ECONOMY

To buy a poor Shoe. Try Good

Cable Screw Wire FOR ECONOMY.

TATEM & DAVENPORT,
Produce Commission Merchants.

Office, No. 1 Delaware Ave. Market,
PHILADELPHIA, PA.

Southern Produce a specialty. Correspondence solicited. Consignors advised daily.

Established 1822.

W. A. COVERT & CO., Produce
Commission Merchants, No. 68 Pearl Street,
New York. "Quick sales and prompt returns." Send for our weekly Prices-current and Marking Plate.

\$600 A MONTH made *honestly* with Stencil and Key-Cheek outfits. Catalogue and samples free. S. M. SPENCER, 117 Haverer St., Boston, Mass.

"Our Preference is the Buckeye."

-American Agriculturist, June, 1872.

TWO FIRST PREMIUM
GRAND MEDALS FOR MERIT
At Vienna, 1873.

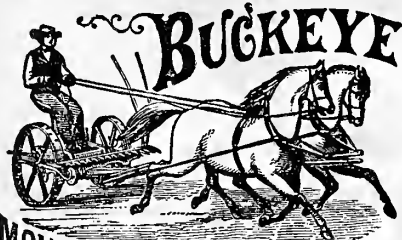

BUCKEYE
MOWER & SELF-RAKING REAPER
OFFICE
165 GREENWICH ST.
N.Y.
FACTORY
POKEEPSIE
N.Y.

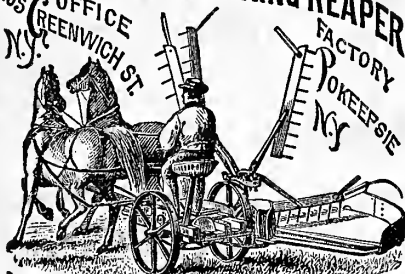

MANUFACTURED BY ADRIANCE, PLATT & CO
STYLES, SIZES & PRICES TO SUIT ALL FARMERS.
Descriptive Circulars Forwarded by Mail.

THE WESTINGHOUSE
Threshing Machines

AND

HORSE POWERS

Are not equaled by any in the market.

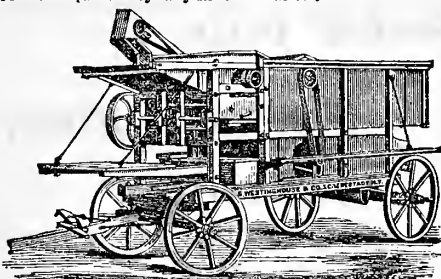

We make 4, 8, and 10 Horse-lever Powers; of 2 and 3 Horse-Tread Powers; and Threshers for steam or any kind of Horse-Powers; also, our Improved Combined Clover and Gram Thresher. Send for Circular.

G. WESTINGHOUSE
Schenectady N. Y.

SPRING
STEEL
TOOTH.
ITHACA
HORSE RAKE.

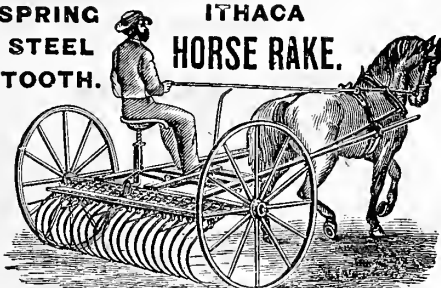

EXCELS ALL OTHERS.

Thousands in use giving entire satisfaction.
Manufactured by
WHEELER & MELICK CO., Albany, N. Y.
WILLIAMS BROS., Ithaca, N. Y.
YOUNGLOVE, MASSEY & CO., Cleveland, O.
GRAND RAKERS MFG CO., Grand Rapids, Mich.

DIRECT
DRAFT
EUREKA
MOWER.

Give away Hay Tedders and Side Cut Machines. Save TIME and MONEY by using

Wilber's Direct Draft Eureka Mower.

You can cut and cure one third more grass in a given time, and gain 25 per cent in quality of hay.

For DESCRIPTIVE CIRCULAR, address
ISAAC W. WHITE, President.
Foughkeepsie, N. Y.

TWO GOLD MEDALS

For "Soon and easy movement of horses, 15 rods less than 1 1/2 miles per hour, mechanical construction of the very best kind, thorough and consistent workmanship and material in every place, nothing slighted, excellent work," etc., as shown by Official Report of Judges, Threshers, Separators, Fanning Mills, Wood Saws, Seed Sowers and Planters, all of the best in the United States of America, Trial sent from Madison, and MINARD HARDER, Cobleskill, Scho. Co., N. Y.

At Great National Trial, at Auburn, N. Y.

Harder's Premium Railway Horse Power, and Thresher and Cleaner, awarded **THE FIRST PRIZE.**

"BEST EVER MADE"

AWARDED THIS MACHINE

MEDAL MACHINES.
NEW YORK STATE AGRICULTURAL WORKS.

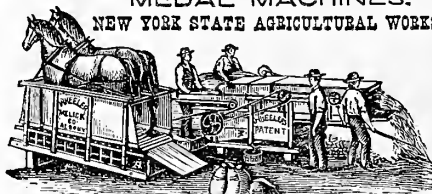

WHEELER & MELICK CO.,
Patentees and Manufacturers of
RAILWAY, CHAIN AND LEVER HORSE POWERS, THRESHERS AND CLEANERS, THRESHERS AND SHAKERS, CLOVER HULLERS, FEED CUTTERS, THACA WHEEL HORSE RAKES, HORSE PITCHFORKS, SHINGLE MACHINES, STRAW PRESERVING RYE THRESHERS, &C., &C.

Send for Circular. ALBANY, N. Y.



FOUST'S PATENT HAY LOADER, manufactured at the MEADVILLE A.G.L. WORKS, Meadville, Pa. Warranted to elevate a ton of hay from the winrow to the wagon in five minutes, and take it as clean as by the hand fork, and to be adapted to all ordinary meadow land. Send for Descriptive Circulars.



CHAPMAN'S. The best Fork and Conveyor in use. Recommended by a host of those who have tried it. Saves labor, time, money. Sent on trial. Agents wanted. Circulars sent.
G. B. WEEKS & CO., SYRACUSE, N. Y.

Straw Preserving Thresher.



This Machine leaves the straw straight and unbroken, when it can again be put into bundles making it more valuable for market. WHEELER & MELICK CO., Sole Manufacturers, Albany, N. Y. Send for circular.

THE SHAKER THRESHER.
A FIRST CLASS SMALL
4 to 6 HORSE LEVER POWER.
WILL THRESH & CLEAN
200 to 400 BU. WHEAT, PER DAY.
SEND FOR CIRCULAR.

BLMYER MFG CO.
CINCINNATI, OHIO.

PENNSYLVANIA
Agricultural Works.

A. B. FARQUHAR, Proprietor,
Manufacturer of the celebrated Farquhar Threshing Machines, steel plows, cultivator teeth, and standard implements generally. Send for circular. Please address
A. B. FARQUHAR, York, Pa.
Or 56 Beekman St., New York.

The Superior Hay Spreader

(Improved and perfected for season of 1874).

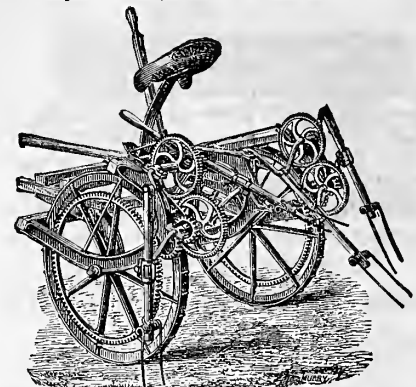

This machine will do the work of ten men. It is the lightest draft machine ever built, one horse working it easily. It has taken first premiums wherever exhibited. Send for a descriptive circular. The Superior Spreader is unsurpassed in beauty, workmanship, and durability.

Manufactured by
THE HIGGANUM MANUFACTURING CO.,
Higganum, Conn.



The Peerless Thresher and Cleaner. Price \$225 and \$245. The Peerless, Straw Preserving Rye Thresher, Overshot. Price \$160.

We make the above a speciality. Railway and Lever Powers.
B. GILL & SON,
Trenton Agricultural Works,
Trenton, N. J.

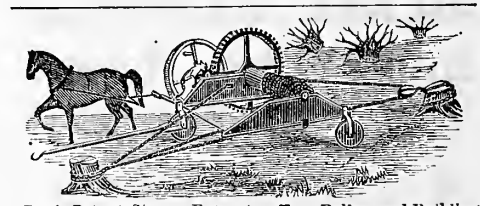

Dye's Patent Stump Extractor, Tree Puller, and Building Mover. The best and only effective Machine. For Machines and State and County Rights, address
ROBERT BRUERE, Imlaystown, N. J.

BUCKEYE DRIER, BAKER AND FEED STEAMER

For full particulars, address
ENGLE, KELLER & CO., Lancaster, Pa.

STANDARD
Cane Machinery,
For Sorgo and Sugar Cane.
The only recognized standards in Cane Machines are the
COOK EVAPORATOR
AND
VICTOR CANE MILL.
There are of these Machines
Over 31,000 in Use.
They have taken the

FIRST PREMIUMS AT 117 STATE FAIRS.
Send for Descriptive Catalogue and Price-List.
BLMYER MANUFACT'G CO., Cincinnati, O.
Shaker Thresher, Corn and Cob Crushers, Wood-Sawing Machines, Farm, School, and Church Bells.

Sugar Cane and Sorgo Machinery,
Steam Engines, Horse Powers,
Farm Mills, etc.

Manufactured by
GEO. L. SQUIER & BRO.,
Catalogues free. Buffalo, N. Y.

CHEAP FARMS!—Fine salt water locations. Good bargains! Send for pamphlet.
J. F. MANCHA, Easton, Md.

The Studebaker Wagon.

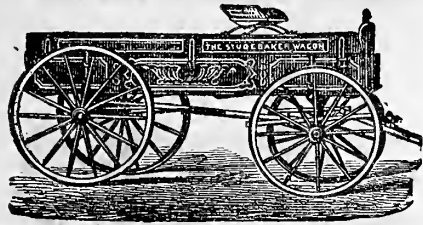

Twenty Years Ago the Smallest,
TO-DAY THE LARGEST,
WAGON WORKS IN THE WORLD!

Puffing and advertising will not maintain the reputation of any manufactured article for any length of time, if it has not REAL MERIT.

Twenty years ago we built FIVE WAGONS A YEAR. TO-DAY WE BUILD 10,000. Do you want better evidence of the superiority of the "Studebaker Wagons"?

Studebaker Bros. Man'g Co.,
SOUTH BEND, IND.

HARNESSES

MANUFACTURED EXPRESSLY



FOR THE

TRACK, ROAD, PARK OR FARM.

Single at \$8, \$12, \$15, \$20, \$25, to \$200 per Set. Double at \$25, \$30, \$35, \$40 to \$500 per Set. Blankets, Sweats, Hoods, Muzzles, Clipping Machines, and Horse furnishing goods of every description, style, and grade, adapted for use on the Track, Road, Farm or Stable.

C. M. MOSEMAN & BRO.,
Manufacturers, 114 Chambers St.
"Send for Descriptive Price-list." New York.

DOUBLE HARPOON,

THE BEST

Horse Hay Fork

made. Descriptive Catalogue sent free.

PENNOCK MANUFACTURING CO.,
Kennett Square, Chester Co., Penn.



SCREW STUMP MACHINE.
Safe, Economical, Cheap, and will pull
the largest Stump with ease.

Send for Circular to
GEO. CHAMBERLAIN & SON, OLEAN, N.Y.

GENUINE

Peruvian Guano.

FARMERS, AGRICULTURISTS, and DEALERS in Fertilizers have now an opportunity of obtaining this valuable manure in small or large lots, at importers' prices, by applying to the Special Agency just established for the purpose of delivering Genuine Peruvian Guano to consumers at any accessible port or railway station in the country. Full particulars given in circular mailed free on application to

R. BALCAZAR,

No. 53 Beaver Street, New York.

REFERENCES BY PERMISSION:

Messrs. HOBSON, HURTADO & Co., Financial Agents of the Peruvian Government, 52 Wall Street, New York.

Moses TAYLOR, Pres. National City Bank, 52 Wall St., N. Y.

J. C. TRACY, Esq., Peruvian Consul, 36 1/2 Broadway, N. Y.

TO FARMERS.



DOUBLE REFINED POUDBRETTE of the "Lodi Manufacturing Co." for sale in lots to suit customers. This article is sold for half the price of other fertilizers, and is cheaper for Buckwheat, Cabbage, and Turnips than any other in market. Price (delivered on board in New York City) \$25 per ton. A Pamphlet giving full directions, etc., sent free on application to
JAMES T. FOSTER,
66 Cortlandt St., New York.

FOR SALE--MANURE

from 180 horses for a year. For particulars, apply to the TROY & LANSINGBURGH R.R. CO., Lansingburgh, N. Y.

Gas Lime Given Away

and put on board vessel, at the Dock of the Brooklyn Gas Light Co., East River, next to Navy Yard.

ROSES, STRONG POT-PLANTS,

Suitable for Immediate Flowering. Sent
Safely by Mail, Post-paid.

5 Splendid Varieties, purchaser's choice, \$1;
12 for \$2. For 10 cents additional we send

MAGNIFICENT PREMIUM ROSE.

Our elegant SPRING CATALOGUE for 1874, describing more than 200 FINEST VARIETIES of ROSES, and containing full directions for culture, with chapters on winter Protection, Injurious insects, etc., now ready. SENT FREE.

THE DINGEE & CONARD CO.,

Rose Growers,

WEST GROVE, Chester County, Pa.

VEGETABLES and FLOWERS.

Send for our Special Price-Lists of Tomatoes, Egg-Plant, Peppers, Sweet Potatoes, CABBAGE, CELERY PLANTS, and FLOWERING PLANTS. All grown from choice Seed. Our Improved Purple Top Yellow Ruta-Baga Turnip Seed can not be excelled, 85 cts. per lb., post-paid; 25 cts. per 1/4 lb. D. H. BROWN & SONS, Seedsmen, 20 Hiram St., New Brunswick, N. J.

CABBAGE PLANTS.—Large stock of best varieties, throughout June and July. By express, very securely packed, \$2.70 per 1,000; \$20 per 10,000. TILLINGHAST BROS., Factoryville, Wyoming Co., Pa.

STRAWBERRY Cultivators and Amateurs.—Please call at my place on the 20th, 21st, 22d, or 23d of June, and examine one of the most superb and valuable Strawberries ever produced. W. M. SOMERS, 456 Pembroke St., East Bridgeport, Ct.

BERRY BASKETS.—General assortment—Six of the most approved kinds. Send early for descriptive lists. R. H. HAINES, Malden, N. Y.



Goodenough Horse-Shoe.

Cheapest and Best. All fitted for Use. No Fires required.

Send for Circulars.
Box 3,044, P. O.,
New York,

CABLE FENCING.

Cheap, handsome, and durable. Proof against Cattle, Fire, and Rust. Hundreds of miles erected. Send for Circulars.

PHILIP S. JUSTICE.

14 North Fifth St., Philadelphia.
42 Cliff St., New York.

Established 1858.



TRADE MARK PATENTED.

The best and cheapest Paint in the world for Iron, Tin or Wood. For sale by the Trade everywhere. PRINCE'S METALLIC PAINT CO., Manufacturers, 96 Cedar St., New York. CAUTION.—Purchasers and consumers are cautioned against imitations of our METALLIC PAINT. All genuine PRINCE'S METALLIC PAINT will bear our name and trade mark on each and every package. Send for a circular.



Improved Foot Lathes.

Small Engine Lathes, Small Gear Cutters, Hand Planers for Metal, Ball Turning Machines, Slide Rests, Foot Scroll Saws. The very best. Selling everywhere. Catalogues free.

N. H. BALDWIN, Laconia, N. H.
Just the articles for Artisans or Amateurs.

BLIND DITCHING PLOW.



Can ditch for 1/4 c. per rod.

For particulars, address

GEO. CHAMBERLAIN & SON OLEAN, N.Y.

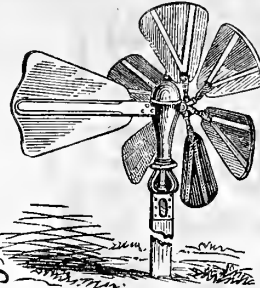

Automatic PUMPS.

Water driven to any height and distance by compressed air; Country houses supplied cheaply and certainly for bath-rooms, water closets, hot and cold water faucets, etc.

Plenty of fresh water for stock on farms.

HARTFORD PUMP CO.,
41 Trumbull St.,
Hartford, Conn.

Agent for New York and vicinity, MASON C. WELD, at the Agricultural Warehouse of R. H. Allen & Co., 189, 191 Water St., where working apparatus may be examined.



Halladay's Improved Wind-Mill.

PERFECTLY Self-Regulating. The Best, Cheapest, most Durable and Popular Mill made. Manufactured under the immediate supervision of inventor 18 years. Two million dollars' worth now in use. Send for Catalogue.

J. S. WIND ENGINE & PUMP CO.
BATAVIA, ILL.

LIVINGSTON & CO., Iron Founders, PITTSBURGH, PA.

Manufacturers of Light Grey Iron

CASTINGS,

For Agricultural Implements, Light Machinery, and Miscellaneous Articles generally

Requiring a Soft and Strong Iron.

Our arrangements for Low Freight to all parts of the country enable us to furnish Good Castings as low as any works East or West.

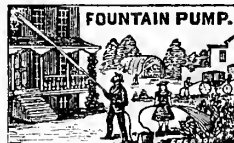

FOUNTAIN PUMP.

GARDEN ENGINE AND FIRE EXTINGUISHER.—For Washing Windows, Carriages, etc. Protects Buildings from Fire, and Trees, Vines, etc., from Insects. Throws water 50 ft. Easily carried. No Dwelling, Country Home, or Factory should be without the Fountain Pump. Send for large

Illustrated Circular. J. A. WHITMAN, Sole Proprietor and Manufacturer, Providence, R. I.

ESSEX PIGS. ESSEX PIGS. ESSEX PIGS. Pure, Well-Bred, Very Choice.

I am now prepared to fill all orders for Pigs promptly. My Spring Pigs are the best I have ever raised. Prices reasonable. I shall have great pleasure in sending a single Pig, pair, or trio to any reader of the American Agriculturist who wishes to improve his stock. The American Express Co. carries my Pigs and Sheep at a reduction of one-third to one-half less than the usual rates for live stock. I guarantee the safe delivery of the Pigs. Orders respectfully solicited. Address

JOSEPH HARRIS,
Moreton Farm,
Rochester, N. Y.

SECOND SALE OF Millwood Farm Jerseys.

To be held June 4th, at 11 o'clock, at Isbury & Walker's, S. 10, and 12 East Street, Boston, Mass. Twenty-three head of Jersey cows, heifers, calves, and young bulls. All registered animals, and bred by myself from my own importations. Catalogues can be had on application to the auctioneers, or to

E. F. BOWDITCH, Framingham, Mass.

FOR SALE.—One Durham bull and heifer with calf, \$150. One Devon bull and two heifers, \$200. Are two years old, best herds, with pedigrees.
J. H. PETTY, No. 1 Pine St., New York.

JERSEY CATTLE. ESSEX PIGS.

For sale by
G. W. FARLEE,
Cresskill, N. J.;
1 hour from N. Y.

EGGS from Fine Stock.—Light Brahma, White Leghorn, S. G. Dorking, S. S. Hamburg, Sebright Bantam—\$2 doz. Partridge Cochins, Dark Brahma, Buff Cochins, Houdan, Avlesbury Duck—\$2.50 doz. Bronze Turkeys—\$4 doz. Send for descriptive catalogue.
W. S. CARPENTER & SON, Rye, Westchester Co., N. Y.

IMPORTANT TO FARMERS,

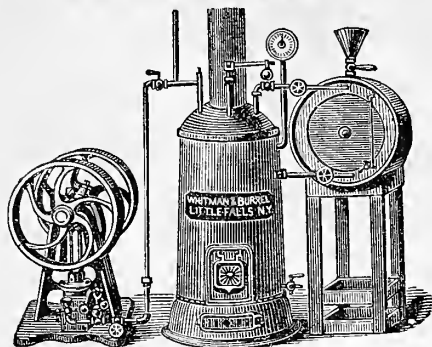

PLANTERS, PRINTERS, BREWERS, AND ALL USING STEAM POWERS.

ANDERSON'S PATENT STEAM BOILER AND KIPP'S NEW ENGINE.

Best and Cheapest in the World! HIGHEST AWARD.

Large Silver Medal at American Institute Fair, fall of 1873, for the best Portable Steam Boiler, 2 to 12 Horse Powers. Also, 1st and Highest Premiums at seven State Fairs and Expositions.

THIS IS NOT A FLUE BOILER.—It is a boiler within a boiler, the two connected together, and presenting an immense amount of heating surface to the fire, and also securing the **Greatest Strength, Durability, and Effectiveness** of any Steam Boiler yet introduced. Over 150 put in on trial, and never lost a sale.

25 to 30 per Cent Saved in Fuel—Five Sizes—2 to 10 Horse Power.—Will raise steam from cold water to 60 pounds pressure in 10 to 12 minutes. **The Most Economical Combination Extant. Feeds itself from a Tank,** and requires no more attention than an ordinary stove, and is just as safe. The engine is of the simplest possible form; the cylinder, bed, frame, guides, and bearings, being all cast in one piece, can not get out of line.

Cheese and Butter Factory Apparatus and Fixtures.
WHITMAN & BURRELL, Manufacturers and Dealers, Little Falls, N. Y.

THE PHILADELPHIA LAWN MOWERS. 1874.

Sizes. { Weight from 28 lbs. to 315 lbs.
 Price from \$15.00 to \$110.00.

Send for Descriptive Circular to

GRAHAM, EMLEN & PASSMORE,

Patentees and Manufacturers, 631 Market St., Philadelphia.

Or to WHOLESALE AGENTS, { R. H. ALLEN & CO., New York,
 W. M. E. BARRETT & CO., Providence, R. I.
 T. HAWLEY & CO., Bridgeport, Conn.
 JOSEPH BRECK & SONS, Boston, Mass.
 J. M. CHILDS & CO., Utica, N. Y.
 CHAS. E. WALBRIDGE, Buffalo, N. Y.
 BOOTH, DOUCE, ROSE & CO., Elmira, N. Y.

New Excelsior Lawn Mower. GREATLY IMPROVED FOR 1874.



It has the Largest Sale of any Lawn Mower in the World!

It has been adopted, and can be seen in practical operation on Central Park and all the other City Parks, New York; Government Grounds and City Parks, Washington; Boston Common, Boston; Prospect Park, Brooklyn; and on almost every prominent Park throughout the United States and Canada.

Four sizes for hand-power; four sizes for horse-power.

Prices from \$15 to \$200.

EVERY MACHINE WARRANTED.

Address

CHADBORN & COLDWELL M'FG CO.,
 Send for Circular. Newburgh, N. Y.

NOW READY.
Celery, Cabbage, and Cauliflower PLANTS,
 And SEEDS of all kinds,
FOR FALL AND WINTER CROPS.
 Price-List mailed free.

Peter Henderson & Co.
 SEEDSMEN AND GROWERS,
 35 Cortlandt Street, New York.

Factory Churns.

At the urgent request of some of the prominent Dairymen of the country, we have designed and made two sizes of **FACTORY CHURNS** which we believe to be every way adapted to the wants of Butter Factories and large Dairies where power is used.

The new No. 8 is intended to churn from 50 to 75 gallons of cream, and the No. 9 from 75 to 150 gallons at a time.

They are just the article needed, and may be obtained through any of our Agents or directly from us.

Prices and details sent on application to the *Sole Manufacturers,*
PORTER BLANCHARD'S SONS,
 Concord, N. H.

FOR HOED CROPS.

Cultivating Plows, Horse Hoes and Cultivators,

and every variety of Implements needed on the Farm, Garden, or Plantation, with the best **SOLUBLE FERTILIZERS** immediately available to the plant, and applicable during cultivation.

Address for circulars,
R. H. ALLEN & CO.,
 189 and 191 Water St.,
 P. O. Box 376. New York City.



LOVEJOY'S METALLIC WEATHER HOUSES

Indicate the changes in the weather, and are pretty mantel ornaments. The little lady appears in fair and the man in stormy weather, and they never make mistakes. Sent prepaid to any address, safely packed, upon receipt of \$2 (Two), by **ALVAN L. LOVEJOY,** Proprietor and Manufacturer, 229 Washington St. Boston.

Special price to dealers.

AGENTS WANTED to sell our justly celebrated Articles for Ladies' wear. Indispensable and absolutely necessary. **10,000 SOLD MONTHLY.** They give comfort and satisfaction. No female can well do without them. Sample sent on receipt of \$2.00 **FREE.** Send for Illustrated Circular. **LE PERLE RUBBER CO.,** 90 Chambers St., New York.

Carbonized Enamel

IS AS PURE AS GLASS.

The Bridgeport M'fg Co.,
 OF BRIDGEPORT, CONN.

(Office, No. 88 Chambers St., New York). Have the exclusive control of this valuable enamel, and are using it to cover all of their celebrated

American Submerged Force Pumps.

They also *enamel pipe* inside and out, which delivers the water chemically pure. The enamel is composed of vegetable matter, baked on so hard that a blow does not break it, and it resists acids that eat gold.

Gentlemen: I have examined the sections of Carbonized Enamel Pipe submitted to me by you. It is superior to any pipe I have ever seen for resisting acids and conducting water from springs or for use in connection with pumps, etc. The Enamel adheres with astonishing tenacity, withstanding even heavy blows; and the surface of the metal where the enamel is beaten off seems to be protected against the ordinary action of water.

M. C. WELD,

Late Associate Editor *Am. Agriculturist.*

MUDGE & WOODS, No. 88 Chambers St., N. Y., are the exclusive selling agents of the Bridgeport M'fg Co. for the Licenses of States, counties, and towns rights for the American Submerged Suction and Force Pumps.

THE PULSOMETER.

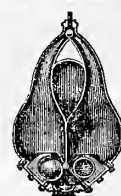

The simplest, most durable, and effective steam pump now in use. Will pump gritty or muddy water without wear or injury to its parts. It can not get out of order.

C. HENRY HALL & CO.,

20 Cortlandt Street, New York City.

BRANCH DEPOSITS:

104 Sudbry St., Boston, Mass.
 1,327 Market St., Philadelphia, Pa.
 59 Wells St., Chicago, Ill.
 South Western Exposition, New Orleans, La.
 811 and 813 North Second St., St. Louis, Mo.

NIAGARA FIRE INSURANCE COMPANY,

201 Broadway, N.Y.

Capital Stock.....\$500,000
 Cash value of Assets.....\$1,308,224
 Total Liabilities.....\$2,302

Net Assets.....\$1,225,922

Dwellings and Farm Risks a specialty at all our Agencies.

HENRY A. HOWE, President.

P. NOTMAN, V. P. and Sec'y.

SELF-ACTING GATES. NICHOLSON'S PATENT.

The best in the world. Address **AMERICAN GATE CO., Cleveland, O.**

THE BEST PAINT IN THE WORLD.



Branch Office and Factory: 506 West Street, NEW YORK, Any Shade from Pure White to Jet Black. A combination of the purest paint, with India Rubber, forming a SMOOTH, GLOSSY, FIRM, DURABLE, ELASTIC, and BEAUTIFUL Paint, unaffected by change of temperature; is perfectly water-proof, and adapted to all classes of work, and is in every way a better paint for either inside or outside painting than any other paint in the world. Being from one fourth to one third cheaper, and lasting at least three times as long, as the best lead and oil paints.

Be sure that our **TRADE-MARK** (a fac-simile of which is given above) is on every Package. Prepared ready for use, and sold by the gallon only. There has never been a paint offered the public that has become so popular (in the same time) and given as perfect satisfaction as the Rubber Paint. Send for sample card and testimonials.

50c., \$1, and \$1.50 PER GALLON.
Cottage Color Paints.

Ground in Oil and mixed ready for use. In cans, kegs, and tubs. Liquid Slate Roof Paint. Cheap, durable, and fire-proof. Send for cards of Colors and Testimonials. **NEW YORK CITY OIL CO., SOLE AGENTS,** 116 Maiden Lane, New York.

AGENTS LOOK!—\$12 a day made selling Scissors Sharpener and other wares. Sample 25 cts. Catalogue free. **T. J. HASTINGS & CO.,** Worcester, Mass.

For the Harvesting Season

We offer the most improved **MOWERS** and **REAPERS, RAKES,** and **SUPERIOR HAY TEDDERS,** with a full assortment of **Farming Tools and Machines, Seeds and Fertilizers.** Address for circulars

R. H. ALLEN & CO.,
189 and 191 Water St.,
P. O. Box 376. New York City.

THE AMERICAN HAY TEDDER.

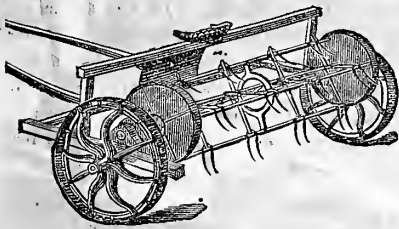

Enables the most important Agricultural product of America to be cut, cured and stored in the barn in one day. Improves the quality and increases the value of the hay crop. Prevents all risk of damage from storms and sudden showers. Is simple, durable and of light draft. Was awarded the New England Agricultural Society's only first prize, at the Great Field Trial, at Amherst, Mass., as being superior to all others, and the best and only perfect machine for tedding or turning hay.

MADE ONLY BY
AMES PLOW COMPANY,
Quincy Hall, Boston,
and 53 Beekman St., New York.
SEND FOR DESCRIPTIVE CIRCULAR.

CHARLES TREMAIN, Manufacturer of the best and cheapest fertilizer in use. **Manlius Plaster.**

ANALYSIS:—"Manlius" pure Gypsum, 94.23; Nova Scotia do., 83.36; Cayuga, 71.75; Virginia do., 62.42.

MANLIUS CEMENT, In use on GOVERNMENT, CITY, and STATE WORKS, RAILROADS, RESERVOIRS, and CISTERNS for strong and ordinary Masonry.

Has received the encomiums of eminent engineers, who place it foremost in the ranks of Hydraulic Cements.
QUICK LIME—A pure caustic Lime for Farmers' and Builders' use.
Special freights obtained. Send for circular.
Works at **MANLIUS, N. Y.**

BAIRD'S BOOKS

For Practical Men.

My new revised and enlarged Catalogue of **PRACTICAL AND SCIENTIFIC BOOKS,** 96 pages, 8vo., will be sent, free of postage, to any one who will favor me with his address.
HENRY CAREY BAIRD,
Industrial Publisher,
406 Walnut St., Philadelphia.

PAINTER'S MANUAL.

Horse and sign painting, graining, varnishing, polishing, kalsomining, papering, lettering, staining, gilding, glazing, silvering, glass staining, analysis of colors, harmony, contrast, etc., 50c. Book of Alphabets, 50c. Book of Scrolls and Ornaments, \$1. Watchmaker and Jeweler's Manual, 50c. Taxidermist's Manual, 50c. Soapmaker's Manual, 25c. Guide to Authorship, 50c. Lightning Calculator, 25c. Employment Seeker's Guide, 25c. Of booksellers, or by mail.
JESSE HANEY & CO., 119 Nassau St., New York.

CLAVERRACK College and Hudson River Inst., at Claverack, N. Y. 20 instructors. **ALONZO FLACK, Ph. D., Pres.**

LIFE AND PUBLIC SERVICES

Charles Sumner.

By C. EDWARDS LESTER.

The second edition ready. Book canvassers can still secure territory, and make money in spite of "hard times." Send for prospectus.
UNITED STATES PUBLISHING CO.,
13 University Place, New York.

AGENTS WANTED for the book **'Tell It All'**

By Mrs. T. B. H. Stenhouse, for 25 years wife of a Mormon High Priest. With introduction by Harriet Beecher Stowe. Two years ago the author wrote a pamphlet on Polygamy which excited the Mormon newspapers to sneeringly invite her to write a book and "Tell It All." The clergy and eminent men and women urged her to accept the challenge. She did so, and "Tell It All" is the result. It is a work of extraordinary interest, full of startling revelations, truthful, bold, and good. The only book upon this subject ever written by a real Mormon woman. The story of "Eliza Ann, Wife No. 19," is told in full by herself. 625 pages, superbly illustrated and bound. It is the most popular book ever sold by agents, outselling all others three to one. It takes like wildfire. \$1.00 will be sold. Steady work or for spare hours for men or women—\$25 to \$200 a month easily made. Descriptive pamphlet, terms, &c., sent free to all, will prove this. Address A. D. WORTHINGTON & Co., Hartford, Conn.

Do you want Employment

We will give you immediate, steady, honorable work, which will pay you beyond all your expectations. Thousands at work for us are now making from \$100 to \$300 per month, and thousands more can do it. The business is in introducing our publications in your own and other towns. With **MARY TWAIN'S** or **JOSH BILLINGS'S** new works, with "MY OPINIONS AND BETSEY BOBBET'S," and with many others out of our list, you can secure a fine income easily. Write us for information. We send it full and free. Address
AMERICAN PUBLISHING CO., Hartford, Conn.

"**EDEOGRAPHY.**" A new book on the art of Writing by Sound; a complete system of Phonetic Short Hand—the shortest, most simple, easy, and comprehensive, enabling any one, in a short time, to report trials, speeches, sermons, &c. The Lord's Prayer is written with forty-nine strokes of the pen, and 140 words per minute. The unemployed should learn this art. Price, by mail, 50 Cts. Agents wanted. Address T. W. EVANS & CO., 139 S. Seventh Street, Phila., Pa.

AGENTS WANTED, everywhere, for **The Home of God's People.**

One of the most singularly attractive, valuable and interesting works ever issued. Every family needs and will have it. It has proved itself to be the best paying book extant, and an energetic male agent will make \$2,500 a year, taking orders for it. Our circulars (sent free) will give you our exceedingly liberal terms, full particulars, endorsements, &c. Old Agents, or any one desiring a lucrative business, will do well to write us at once. Address,
DUS. IN, GILMAN & CO., Hartford, Conn.

The Best Work Ever Issued for Farmers, Carpenters, and Mechanics, is

BELL'S Carpentry Made Easy.

It is useful to all who have barns, bridges, and out-houses to build, as it treats on the science and art of Framing on a new and improved system, with specific instructions for building Balloon Frames, Barn Frames, Mill Frames, Warehouses, etc.

Nicholson says of "Carpentry":
"With an experience of more than twenty-four years at carpentering, I may say it is the best work of the kind I have ever had the good fortune to meet with, as it gives more information for the amount of money, either to Master Workman or Journeyman, the principles being so different from other works of the kind, yet so plain that any apprentice should be able to comprehend them in a short time."
JOHN J. NICHOLSON.

Another Carpenter says: "It is just the book for a young beginner."

PRICE, \$5.00, Prepaid.
HOWARD CHALLEN, Publisher, Philadelphia, Pa.

Scribner's Lumber & Log-Book.

OVER HALF A MILLION COPIES SOLD. This book is the most full and complete book of its kind ever published. It gives correct measurement of all kinds of lumber, logs, plank, cubical contents of square and round timber, stave and heading bolt tables, wages, rent, board, capacity of cisterns, cord-wood tables, interest, etc., and has become the Standard Book throughout the United States and Canada.

Be sure and get the New Edition, with Doyle's Log-Table. Ask your bookseller for it, or 1 cent per copy for 35 cents, post-paid. **G. W. FISHER, P. O. Box 338, Rochester, N. Y.**

MAGIC PHOTOGRAPHS.

Wonderful! Curious! Amusing!
25 cents a package; 5 assorted packages \$1; one dozen assorted packages \$2. Sent to any address, postage paid, on receipt of price. Address
PUZZLE COMPANY, 755 Broadway, New York.

WATERS' CONCERTO PARLOR ORGANS



are the most beautiful in style and perfect in tone ever made. The **CONCERTO STOP** is the best ever placed in any Organ. It is produced by an extra set of reeds peculiarly voiced, the EFFECT of which is MOST CHARMING and SOUL STIRRING, while its IMITATION of the HUMAN VOICE is SUPERB. Terms liberal.
WATERS' Philharmonic Vesper and Orchestral ORGANS, in UNIQUE FRENCH CASES, are among the best made, and combine PURITY of VOICING with great volume of tone. Suitable for PARLOR, CHURCH, or MUSIC HALL.
WATERS' New Scale PIANOS have great power and a fine singing tone, with all modern improvements, and are the BEST PIANOS MADE. These Organs and Pianos are warranted for 6 years. PRICES EXTREMELY LOW for cash or part cash, and balance in monthly or quarterly payments. Second-hand instruments taken in exchange. **AGENTS WANTED** in every County in the U. S. and Canada. A liberal discount to Teachers, Ministers, Churches, Schools, Lodges, etc. ILLUSTRATED CATALOGUES MAILED.
HORACE WATERS & SON,
451 Broadway, New York. P. O. Box 3567.

THE PATENT **ARION** PIANO-FORTE

Excels all others in Tone and Durability, and in Elegance of Finish they are Unsurpassed.

These Pianos are used exclusively in the New York Conservatory of Music, and are recommended by the Profession and the Press throughout the United States. Before purchasing, write for Illustrated Pamphlet, and mention the *Agriculturist*.
ARION PIANO-FORTE CO.,
No. 5 East 14th Street, New York City.

PIANOS for Rent with Privilege of Purchase. We Rent elegant first-class Pianos at very moderate rates, and allow the Rent to pay for the instrument. By our new rental system a person can have from Two to Seven Years to pay for a Piano. Any responsible person wishing a first-class Piano on Easy Payments should send stamp for our new Illustrated Catalogue with full particulars. Address
S. BRAINARD'S SONS, Cleveland, Ohio.

THE SABBATH. Greatest and Latest of Church Choir Books.

For all denominations. \$13.50 a doz. Sample copy, \$1.25
CLARKE'S NEW METHOD FOR THE PIANO-FORTE. THE BEST OF INSTRUCTION BOOKS. Has the endorsement of all good teachers who have examined it. Sent by mail, \$3.75.

"**THE AMATEUR.**" THE GREAT MUSICAL MONTHLY! ELEVEN pages of new music—and NINE pages of musical matter in each number. Sample copy, 10 cts. Subscription, including beautiful CHROMO, \$1.00 per year.
LEE & WALKER'S MUSICAL ALMANAC.
Sent free to any address.

GETZE'S SCHOOL FOR THE ORGAN. "THE UNRIVALLED INSTRUCTOR." The best work for teachers and pupils.
Sent by Mail, price, \$2.50.
Lee & Walker, 922 Chestnut St. Philadelphia.

SONGS of GRACE & GLORY

The very best Sunday-School Song Book. By W. F. SHERWIN and S. J. VAIL. 160 Pages Splendid Hymns, Choice Music, Tinted Paper, Superior Binding. Price in Boards, 35c.; \$30 per 100. A Specimen Copy in Paper Cover mailed for Twenty-five Cents.
Six New Songs in pamphlet form, for ANNIVERSARIES, from "SONGS OF GRACE and GLORY." Price \$2 per 100. Specimen copy of the Anniversary Songs, and 6 sample pages of the Book, mailed for 3 cent stamp. Publishers,
HORACE WATERS & SON,
451 Broadway, New York. P. O. Box 3567.

SUPERIOR STANDARD WORKS.

Published by **ORANGE JUDD COMPANY.**

THE HORSE.

**FRANK FORESTER'S
HORSE OF AMERICA.**



By **HENRY WM. HERBERT.**

Revised, corrected, enlarged, and continued to 1871,
By **S. D. and B. G. BRUCE.**

Always an **ACKNOWLEDGED STANDARD**, and now
the most **COMPLETE and AUTHENTIC** Work on the
HORSE. With steel-engraved portraits of Thirty
of the most famous

REPRESENTATIVE HORSES,

including pedigrees, histories, and performances.
Two superb royal octavo volumes of upward of 1300 pages.

Post-Paid, Ten Dollars.



**WALLACE'S
American Trotting Register.**

CONTAINING ALL THAT IS KNOWN OF THE

PEDIGREES OF TROTTING HORSES,

their ancestors and descendants, with a record of

All-published performances in which a mile
was trotted or paced in 2.40 or less,

from the earliest dates until the close of 1868, and
a full record of the performances of 1869 and 1870.

Giving complete Summaries of over 6,000 Contests.

With an **INTRODUCTORY ESSAY** on the true
origin of the American Trotter. And a set of **Rules** for
the government of all trials of speed. By **J. H. WALLACE**, compiler of Wallace's American
Stud-Book. Royal octavo.

Post-paid, Ten Dollars.

WALLACE'S AMERICAN STUD-BOOK.

VOL. ONE. BEING A COMPILATION OF THE

PEDIGREES OF AMERICAN AND IMPORTED BLOOD HORSES,

from the earliest records, with an **APPENDIX** of all
named animals without extended Pedigrees prior
to the year 1840. And a **SUPPLEMENT**, containing a
history of all Horses and Mares that have trotted in
public from the earliest trotting races until the
close of 1866. By **J. H. WALLACE.** Royal octavo
of over 1000-pages elegantly bound in extra cloth,
beveled boards, and splendidly illustrated.

Post-paid, Ten Dollars.

Horse Portraiture. — BREEDING,

REARING, AND TRAINING TROTTERS. Prepara-
tions for Races, Management in the Stable, on
the Track, Horse Life, etc. By **JOSEPH CAIRN**
SIMPSON. Post octavo. Post-paid, \$3.00.

FIELD SPORTS.



Frank Forester's Field Sports.

Embracing the Game of North America, Upland Shoot-
ing, Bay Shooting, Wild Sporting of the Wilderness,
Forest, Prairie, and Mountain Sports, Bear Hunting,
Turkey Shooting, etc. 13th edition, revised and illus-
trated. Two post octavo volumes. Post-paid, \$6.00.

Frank Forester's Fish and Fishing.

100 engravings. Embracing a full illustrated description
of the Game Fish of North America; Trout and Salmon
Fishing; Shoal Water and Deep Sea Fishing; Lake and
River Fishing; Trolling, Fly Fishing, etc. 12th edition.
One post octavo volume. Post-paid, \$3.50.

Frank Forester's Complete Manual.

For Young Sportsmen, of Fowling, Fishing, and Field
Sports. With directions for handling the Gun, the Rifle,
and the Rod. Art of Shooting on the Wing. The Break-
ing, Management, and Hunting of the Dog. The varie-
ties and habits of Game. River, Lake, and Sea Fishing.
Post octavo. Post-paid, \$3.00.

**Frank Forester's American Game in its
SEASONS, Fully Illustrated and Described. New edi-
tion. post-paid, \$3.40.**

The Dog.

By Dinks, Mayhew & Hutchinson. Compiled and edited
by Frank Forester. Containing full instructions in all
that relates to the Breeding, Rearing, Breaking, Kennel-
ing, and Conditioning of Dogs, with valuable recipes for
the treatment of all diseases. Illustrated. Post octavo.
Post-paid, \$3.00.

The Dead Shot:

Or, Sportsman's Complete Guide; a Treatise on the use
of the Gun, with Rudimentary and Finishing Lessons in
the Art of Shooting Game of all kinds. By Marksman.
Post-paid, \$1.75.

The Crack Shot:

Or, Young Rifleman's Complete Guide; being a Treatise
on the use of the Rifle, with Lessons, including a full de-
scription of the latest improved breech-loading weapons;
rules and regulations for Target Practice, and directions
for Hunting Game. By Edward C. Barber. Post-paid, \$1.75.

Gun, Rod, and Saddle.

Nearly fifty practical articles on subjects connected with
Fishing, Shooting, Racing, Trotting, etc. Post-paid, \$1.

Practical Trout Culture.

By J. H. Slack, M. D., Commissioner of Fisheries, New
Jersey. Fully illustrated and describing thoroughly all
that is requisite to successful Trout Culture. Post-paid,
\$1.50.

AGRICULTURE.

**Woodward's Graperies and Horticultural
BUILDINGS.** Designs and Plans of Hot-beds, Cold Pits,
Propagating Houses, Forcing Houses, Hot and Cold
Graperies, Greenhouses, Conservatories, Orchard Houses,
etc., with the various modes of Ventilating and Heating.
Post-paid, \$1.50.

**Jacques' Manual of the Garden, Farm,
AND BARN-YARD.** Embracing the Cultivation of
Vegetables, Fruit, Flowers, all Field Crops, Details of
Farm Work and Rearing Domestic Animals. New and
Revised Edition. One volume. Post-paid, \$1.75.

Young Farmer's Manual.

VOL. I. The Farm and the Workshop, with Practical
Directions for laying out a Farm, Erecting Buildings,
Fences, Farm Gates, Selecting good Farm and Shop
Tools, and performing Farm Operations. Fully illus-
trated. Post-paid, \$1.75.

Young Farmer's Manual.

VOL. II. How to Make Farming Pay, with full Details of
Farm Management, Character of Soils, Plowing, Manage-
ment of Grass Lands, Manures, Farm Implements, Stock,
Drainage, Planting, Harvesting, etc. Illustrated. Post-
paid, \$1.75.

Husmann's Grapes and Wine.

The Cultivation of the Native Grape and Manufacture
of American Wine. By Geo. Husmann, of Missouri.
Post-paid, \$1.50.

Elliott's Lawn and Shade Trees.

For Planting Parks, Gardens, Cemeteries, Private
Grounds, and Avenues. Fully illustrated and described.
Post-paid, \$1.50.

Fuller's Forest Tree Culturist.

The Cultivation of Forest Trees for Shade, for Shelter,
for Fuel, for Timber, and for Profit. Illustrated. Post-
paid, \$1.50.

ORANGE JUDD COMPANY, 245 Broadway, N. Y.

A Man of Honor.

By **GEORGE CARY EGGLESTON.**

Finely Illustrated.

The publishers take pleasure in commending this as
one of the most charming stories that has been presented
to the American people. Mr. Eggleston has given to it,
with rare fidelity, the local coloring of the part of the
country where its scenes are laid. It is a realistic story
of life in the Old Dominion. Its people are ladies and
gentlemen. Robert Pagebrook, the "Man of Honor," is
every inch a man, and his sayings and doings at once at-
tract and hold the reader's attentive interest. It is a
love-story, too, and has the merit, which is not as com-
mon as it might be nowadays, of ending to the reader's
entire satisfaction.

NOTICES BY THE PRESS.

A capital picture of Life in Old Virginia before the war is
to be found in Mr. George Cary Eggleston's "A Man of
Honor." Virginian hospitality, Virginian cousinship, Vir-
ginian housekeeping, are portrayed in accurate and attrac-
tive colors. It is a life which the author has himself known
and loved, and he writes of it with a warmth that comes
from the heart.—*N. Y. Evening Post.*

Really readable in the most refreshing sense of the term—
a story of the most amusing and attractive interest.—*St.
Louis Times.*

It is written in an off-hand manner, and is bright and
amusing.—*Worcester, Mass., Spy.*

With Virginian life as a specialty, Mr. Eggleston has drawn
a simple, straightforward, truthful, and withal, artistic pic-
ture of Southern society. It is sketchy, perhaps too much
so, but the sketches are all vigorous and show the hand of a
practiced artist. In forming the characters of his book it is
evident that Mr. Eggleston has drawn oftener on his memory
than on his imagination; that he has lived among the people
whom he describes, has heard them talk, and seen them
under all the moods of ordinary life.—*Boston Daily Adver-
tiser.*

CONTENTS.

Chapter 1. Mr. Pagebrook gets up and calls an Ancient
Lawgiver.—2. Mr. Pagebrook is Invited to Break-
fast.—3. Mr. Pagebrook Eats his Breakfast.—4. Mr.
Pagebrook Learns Something about the Customs of
the Country.—5. Mr. Pagebrook Makes some Acquain-
tances.—6. Mr. Pagebrook Makes a Good Impression.
—7. Mr. Pagebrook Learns Several Things.—8. Miss
Sudie Makes an Apt Quotation.—9. Mr. Pagebrook Meets
an Acquaintance.—10. Chiefly Concerning "Foggy."—
11. Mr. Pagebrook Rides.—12. Mr. Pagebrook Dines
with his Cousin Sarah Ann.—13. Concerning the Rivu-
lets of Blue Blood.—14. Mr. Pagebrook Manages to
be in at the Death.—15. Some very Unreasonable
Conduct.—16. What Occurred Next Morning.—17. In
which Mr. Pagebrook Bids his Friends Good-by.—18.
Mr. Pagebrook Goes to Work.—19. A Short Chapter,
not very Interesting, perhaps, but of some Importance
in the Story, as the Reader will probably Discover after
awhile.—20. Cousin Sarah Ann Takes Robert's Part.
—21. Miss Barksdale Expresses some Opinions.—22.
Mr. Sharp Does his Duty.—23. Mr. Pagebrook Takes
a Lesson in the Law.—24. Mr. Pagebrook Cuts Himself
Loose from the Past and Plans a Future.—25. In which
Miss Sudie Acts very Unreasonably.—26. In which Miss
Sudie adopts the Socratic Method.—27. Mr. Pagebrook
Accepts an Invitation to Lunch and Another Invitation.
28. Major Pagebrook Asserts Himself.—29. Mr. Barksdale
the Younger goes upon a Journey.—30. The Younger
Mr. Barksdale Asks to be Put upon his Oath.—31. Mr.
William Barksdale Explains.—32. Which is also the
Last.

ILLUSTRATIONS.—By M. Woolf.

"Now I've Got You" (Frontispiece).—Mr. Robert
Pagebrook was "Blue."—"I Fall at Once into a Chronic
State of Washing up Things."—"Foggy."—Cousin
Sarah Ann.—The Rivulets of Blue Blood.—Miss Sudie
Declares Herself "so Glad."—"Let Him Serve it at Once,
Then."—"Very Well, Then."—"I'm as Proud and as
Glad as a Boy with Red Morocco Tops to his Boots."

PRICE, POST-PAID \$1.25

**ORANGE JUDD COMPANY,
245 BROADWAY, NEW YORK.**

**DON'T FAIL
TO HAVE A LIBRARY.
GOOD BOOKS
For Farmers' Libraries.**

In response to a request made of one whose thorough and practical knowledge on all matters pertaining to the Farm, Garden, and Household is so fully conceded that his opinions could not fail to secure attention and command respect were we permitted to give his name, we have received the following as his judgment concerning some of the works on our Catalogue of Books for Farmers.

Any of these Books will be forwarded, post-paid, to any address in the United States or Territories, on receipt of the price, by Orange Judd Company, 215 Broadway, New York.

For a Farmer's Library.

How Crops Grow,
(price \$2.00), and

How Crops Feed,
(price \$2.00.)

By Prof. SAM'L W. JOHNSON.

If I could have but two books in such a library it would be these, as I consider them the most important contributions to agricultural literature of modern times. They contain all of vegetable physiology and agricultural chemistry that any except special students need, and nowhere is there so much of agriculture condensed in so small a space. As works of reference they are indispensable.

Farm Implements and Machinery.

By JOHN J. THOMAS.
Price \$1.50.

Most farming operations are accomplished by force, applied through implements and machines, and a farmer should understand mechanics, at least sufficiently to apply force most economically. In this work the fundamental principles are clearly taught, and their application illustrated.

The New American Farm Book.

By R. L. and L. F. ALLEN
Price \$2.50.

This is the best American work upon general farm management. It treats of the leading crops, buildings, draining, etc., and includes sufficient about animals of different kinds to meet the wants of most farmers.

American Weeds and Useful Plants.

By DR. WM. DARLINGTON.
Price \$1.75.

For the farmer who wishes to know something about the weeds upon his farm, as well as useful cultivated and wild plants, this will answer better than a general treatise on botany.

Country and Suburban Homes.

By D. T. ATWOOD.
Price \$1.50.

Such a library should have some work on domestic architecture. Most works upon the subject are costly on account of the designs. This is one of the best works, at a moderate price, and contains, with other matter, the method of building with concrete.

The Fruit Garden.

By P. BARRY. Price \$2.50.

After the farm crops, fruit is of the most importance. No work covers the whole subject so completely as this.

Gardening for Profit.

By PETER HENDERSON.
Price \$1.50.

Farms near cities often make more from garden crops than from farm crops. This is the best work on market gardening, and will serve for the family garden also.

Gardening for the South.

By WM. N. WHITE.
Price \$2.00.

An excellent garden book, and in the libraries for Southern farmers might be substituted for Henderson's, but it would be well to have both.

The New Book of Flowers.

By JOSEPH BRECK.
Price \$1.75.

I do not know of any book upon out-door flower gardening that on the whole is so good as this. Its teachings are sound, and style pleasing.

Mysteries of Bee-Keeping.

By M. QUINBY. Price \$1.50.

Practical Poultry-Keeper.

By L. WRIGHT. Price \$2.00.

The Pig.

By JOSEPH HARRIS.
Price \$1.50.

Draining for Profit.

By GEO. E. WARING, JR.
Price \$1.50.

Dairy Husbandry.

By X. A. WILLARD.
Price \$3.00.

Bees, Poultry, and Pigs are often made subjects of especial care by small farmers, and separate treatises on these are more likely to be asked for in a library like this than those upon the larger animals. Each of these is the best in its line.

So in farm operations, those of Draining and Dairying, especially the factory system, are not likely to be treated sufficiently in detail in general works.

As all the other works are matters of fact, it may be well to have a little pleasure. This conveys much sound teaching on rural economy in a quaint style, and it is sometimes policy to sugar-coat your pill.

Tim Bunker Papers.

Price \$1.50.

Books for a Larger Library.

Besides all the works in the foregoing list, I would add the following:

- American Cattle.** L. F. ALLEN. \$2.50.
- Randall's Sheep Husbandry.** \$1.50.
- Hints to Horse Keepers.** H. W. HERBERT. \$1.75.
- American Cattle Doctor.** G. H. DADD. \$1.50.
- Insects Injurious to Vegetation.**
DR. HARRIS. \$4.00.
- Fruits and Fruit Trees of America.**
DOWNING. \$5.00.
- Cranberry Culture.** J. J. WHITE. \$1.25.
- Grape Culturist.** A. S. FULLER. \$1.50. (For the West would substitute Husman's Grapes and Wine. \$1.50.)
- Grasses and Forage Plants.**
C. L. FLINT. \$2.50.
- Forest Trees.** ARTHUR BRYANT. \$1.50.
- Landscape Gardening.** KEMP. \$2.50.
- Hops.** 40 cts. **Flax.** 50 cts. **Tobacco.** 25 cts. **Onion.** 20 cts. Essays.
- Boussingault's Rural Economy.** \$1.60.
- Play and Profit in My Garden.** ROE. \$1.50.
- Window Gardening.** WILLIAMS. \$1.50.

Books for a Still Larger Library.

In addition to those mentioned in the other two lists, I would name the following.

- Animals and Plants under Domestication.** 2 vols. CHAS. DARWIN. \$6. (This not suggested for its doctrine, but as a useful work of reference.)
- Hussey's National Cottage Architecture.** \$6.
- Landscape Gardening.** DOWNING. \$6.50.
- The Vegetables of America.** F. BURR. \$5.
- The Book of Evergreens.** J. HOOPES. \$3.
- Trout Culture.** DR. SLACK. \$1.50.
- Farm Gardening & Seed Growing.** BRILL. \$1.
- The Dog.** DINKS, MATHEW & HUTCHINSON. \$3.
- Young Sportsman's Manual.** FORRESTER. \$3.
- Hunter and Trapper.** H. THRASHER. \$1.
- The Market Assistant.** DEVOE. \$2.50.
- Hedges and Evergreens.** WARDER. \$1.50.
- Pear Culture.** P. T. QUINN. \$1.
- Money in the Garden.** QUINN. \$1.50.
- How Plants Grow.** GRAY. \$1.25.
- How Plants Behave.** GRAY. 75 cts.
- Illustrated Horse Doctor.** MAYHEW. \$3.
- Peach Culture.** FULTON. \$1.50.
- Barns, Out-Buildings & Fences.** HARNEY. \$6.
- Cottages and Farm Houses.** WOODWARD. \$1.50.
- Country Homes.** WOODWARD. \$1.50.

Newly Revised and Enlarged Edition.

Practical Floriculture.

A Guide to the Successful Propagation and Cultivation of Florists' Plants.

By PETER HENDERSON,
Author of "Gardening for Profit."

Beautifully Illustrated. Price, Post-paid, \$1.50.

In this work, which has everywhere become so deservedly popular, not only is the whole "art and mystery" of propagation explained, but the reader is taught how to plant and grow the plants after they have been propagated. The work is not one for florists and gardeners only, but the amateur's wants are constantly kept in mind, and we have a very complete treatise on the cultivation of flowers under glass, or in the open air, suited to those who grow flowers for pleasure as well as those who make them a matter of trade. The work is characterized by the same radical common sense that marked the author's "Gardening for Profit," and it holds a high place in the estimation of lovers of floriculture. The new edition has been thoroughly revised by the author, and much enlarged by the addition of valuable matter.

The following are a few of the subjects embraced in the latest edition:

Laying out Flower Garden and Lawn; Designs for Grounds and for Greenhouses; Soils for Potting; Cold Frames; Hot-Beds; Greenhouses Attached to Dwellings; Modes of Heating; Propagation of Plants by Seeds and by Cuttings; Culture of the Rose and Tuberoses; Growing of Winter-flowering Plants; Construction of Bouquets, Baskets, etc.; Parlor and Window-Gardening; Wardian-Cases and Ferneries; Insects; What Flowers Grow in the Shade; Culture of Grape-Vines under Glass; The Profits of Floriculture; How to Become a Florist, etc., etc.

**THE ILLUSTRATED
Book of Poultry,**

With Practical Schedules for Judging, Constructed from Actual Analysis of the Best Modern Decisions.

By LEWIS WRIGHT,

Author of "The Practical Poultry Keeper," "The Brahma Fowl," etc.

**ILLUSTRATED WITH
Fifty Colored Portraits of Prize Birds,
Painted from Life by J. W. Ludlow.**

CONTENTS.

- | | |
|---|---|
| CHAP. 1.—Houses and Accommodation. | CHAP. 19.—Brahmas. |
| 2.—The Selection of Stock. | 20.—Malays. |
| 3.—Feeding and General Treatment of Fowls. | 21.—Game. |
| 4.—Eggs and Incubation. | 22.—Dorkings. |
| 5.—Artificial Hatching. | 23.—Spanish. |
| 6.—The Management of Chickens. | 24.—Hamburgs. |
| 7.—Fattening and Killing. | 25.—Polish Fowls. |
| 8.—Poultry as National Food. | 26.—French Breeds of Poultry. |
| 9.—The Utility of "Fancy Points." | 27.—American Breeds of Poultry. |
| 10.—Commencing a Strain. | 28.—Unclassed Varieties of Poultry. |
| 11.—Mating Stock for Breeding Prize Birds. | 29.—Bantams (Except Game). |
| 12.—Rearing, Care, and Exhibition of Prize Poultry. | 30.—Game Bantams. |
| 13.—Shows and Judging. | 31.—Wild Breeds of Poultry. |
| 14.—Buying, Selling, and Exporting. | 32.—Origin of the Domestic Fowl. |
| 15.—Enemies in the Yard. | 33.—The Guinea Fowl. |
| 16.—Diseases of Poultry. | 34.—The Turkey. |
| 17.—Technical Terms. | 35.—The Pea Fowl. |
| 18.—Cochins. | 36.—Ducks. |
| | 37.—Geese. |
| | 38.—Swans. |
| | 39.—Possible Additions to the Poultry Yard. |

Price, Postpaid - - - \$15 00

Either of the above books sent post-paid on receipt of price by

ORANGE JUDD COMPANY,
245 BROADWAY, NEW YORK.

ORANGE JUDD COMPANY,
245 BROADWAY, NEW YORK.

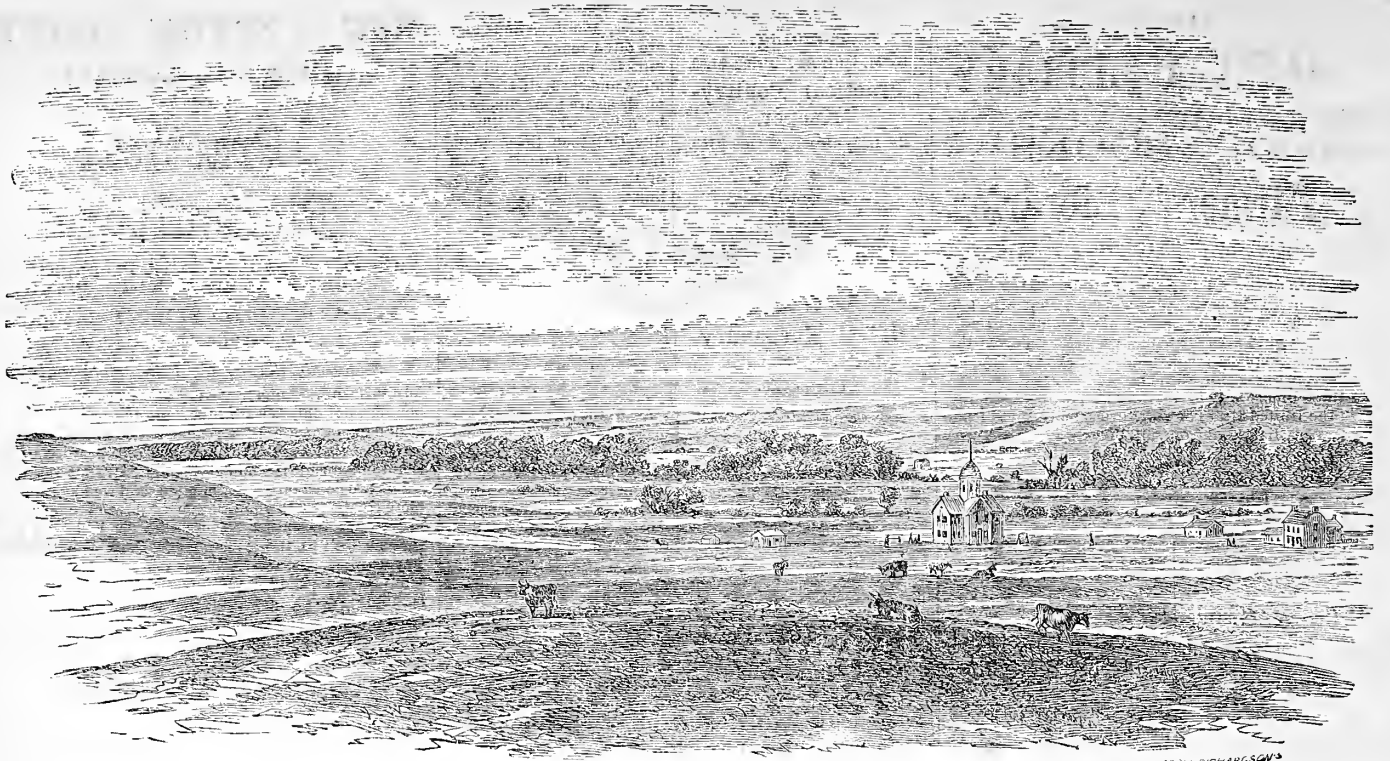

DOANE COLLEGE, IN SOUTH PART OF CRETE, NEB.

This is a fair representative view of Valley, Rolling Prairie, and Timber Lands for over sixty miles in Gage, Salina, Seward, and Butler Counties, in Nebraska.

**IF YOU WANT A FARM OR HOME,
YOU SHOULD BUY OF THE
BURLINGTON AND MISSOURI RIVER RAILROAD CO.
IN IOWA OR NEBRASKA.**

- BECAUSE**—Their prices are low, ranging for the best land from Three to Ten Dollars per acre.
- BECAUSE**—No payments are required of the purchaser for four years, except interest at six per cent.
- BECAUSE**—After the fourth year only one seventh of the principal is payable annually till the whole is paid.
- BECAUSE**—You are not required to go into a wilderness, these being well-settled States, the population of which is rapidly increasing.
- BECAUSE**—The mildness of the climate and fertility of the soil is such that the settler can pay for his farm from the products raised upon it long before the time when the principal becomes due.
- BECAUSE**—Failure of crops from drouth is unknown.
- BECAUSE**—Large allowances are made upon fare and freight, thus giving low rates on both to purchasers of this Company's lands.

AND YOU SHOULD BUY THIS YEAR.

BECAUSE—Purchasers of our lands in Nebraska during 1871 who cultivate one-half their land within two years from their purchase are allowed a reduction of twenty per cent on its price. **LARGE DISCOUNTS** also, FOR CASH, within One, Two, or Five Years.

Send for Circulars, with full information on all points, to

CEO. S. HARRIS, Land Commissioner,
At Lincoln, Nebraska, for land in Nebraska. At Burlington, Iowa for land in Iowa.
JAS. R. WOOD, General Agent, 59 Clark St., Chicago, Ill.

Or to **W. D. COWLES**, General Agent, 317 Broadway, New York.

**THE PALMER
Combination Attachment
For Sewing Machines.**

Received the GRAND PRIZE MEDAL at the American Institute Fair, New York, 1873. New Jersey State Fair, 1873. Western New York Fair, 1873.

- Sews** THE PALMER ATTACHMENT Without basting.
- Hems** THE PALMER ATTACHMENT all goods BIAS OR STRAIGHT.
- Binds** THE PALMER ATTACHMENT with BRAID OF CUT BENDING. Scallops and Points.
- Gathers** THE PALMER ATTACHMENT plain—and SEWS TO A BAND AT SAME TIME, if desired.
- Cords** THE PALMER ATTACHMENT bias bands and places a
- Cord Welt** of DIFFERENT COLORS into the gathering seam, at the same time SEWING ON if desired, at one operation, and all without basting. It prepares and applies a
- FRENCH HEM** and places a
- Fold** in any seam WITHOUT BASTING. Makes
- FRENCH FOLDS** EIGHT DIFFERENT KINDS OF including the celebrated
- Milliners' and Dressmakers' Fold** in One and also in Two Colors.

The Palmer Attachment combines all the principal attachments in use, amounting, when sold, to from \$15 to \$20. DRESSMAKERS can save its entire cost in one day, and to all having a Sewing Machine it is invaluable. SAVE YOUR MONEY and buy the most useful and popular selling article ever offered to the public.

A limited number for sale of the above excellent attachments, adapted to the "Singers," "Willcox & Gibbs," "Weed," and "Domestic" machines. Regular price \$4.00. Sent by mail, post-paid, with full directions for use, for \$2.50 each. Address

J. E. JEWETT,
245 Broadway, New York.
REFER TO ORANGE JUDD COMPANY.

Samples from
B. E. Hale & Co.,
56 and 58 Park
Place, N. Y.
Sole Agents for
Eastern States.

BUILDING PAPER!
FOR SHEATHING, ROOFING, DEAFENING, CARPET LINING, AND PLASTERING!

Rock River Paper Company,
Chicago, Ills.

**EVERY LADY SHOULD HAVE A SET OF
GOODRICH'S "SPRING" HEMMERS**
Consisting of Four Widths and a Dress Binder. Sent by Mail on Receipt of Price.
For Sale by all Sewing Machine Agents. } H. C. GOODRICH, { 205 State Street, CHICAGO, ILL.
\$5 Price, Only One Dollar. } { 103 N. 10th St., PHILADELPHIA, PA.
Inventor of The Goodrich Tuck Marker.

FLORENCE
The Long-contested Suit of the FLORENCE SEWING MACHINE CO. against the Singer, Wheeler & Wilcox, and Grover & Baker Companies, involving over \$250,000.
Is finally decided by the Supreme Court of the United States in favor of the FLORENCE CO., which alone has Broken the Monopoly of High Prices.
THE NEW FLORENCE.
Is the ONLY machine that sews backward and forward, or to right and left. Simplest—Cheapest—Best.
SOLD FOR CASH ONLY. SPECIAL TERMS TO CLUBS and DEALERS.
April, 1874. Florence, Mass.



AGENTS wanted—Male or female—to sell our Patent Spool Holder, Thread Cutter, and Needle Threader combined. Just out. Sample box of two styles, by mail, 75 ct. Also other novelties. Send for circulars. Address PLUMB & Co., Philadelphia Pa.

WANTED—Agents—\$75 to \$250
per month, everywhere, male and female, to introduce the GENUINE IMPROVED COMMON SENSE FAMILY SEWING MACHINE. This Machine will stitch, hem, fell, tuck, quilt, cord, bind, braid, and embroider in a most superior manner. Price only \$15. Fully licensed and warranted for five years. We will pay \$1,000 for any machine that will sew a stronger, more beautiful, or more elastic seam than ours. Address SECOMB & CO., Boston, Mass.; New York City; Pittsburgh, Pa.; Chicago, Ill.; or St. Louis, Mo.

\$200 A MONTH TO AGENTS
to sell the IMPROVED "HOME SHUTTLE" SEWING MACHINE, a practical, low-priced "Lock Stitch" Sewing Machine. Address JOHNSON, CLARK & CO., Boston, Mass., New York City; Pittsburgh, Pa.; Chicago, Ill.; Louisville, Ky.; or St. Louis, Mo.

HOW TO MAKE MONEY AT HOME. 60 pp. Book free. J. JAY GOULD, Boston, Mass.

THE HOOSIER SCHOOL-MASTER.

By EDWARD EGGLESTON.

Finely Illustrated, with 12 Full-Page Engravings, and Numerous Other Cuts.

NOTICES BY THE PRESS.

It is full of quaint humor, a tender pathos, and vivid descriptions.—*New York Standard*.

The "events" are stirring and dramatic, and the style is quiet, impersonal, and almost epigrammatic in its ability to lay bare an entire situation or character in a sentence or phrase.—*Brooklyn Daily Eagle*.

It is at once quaint and truthful, and illustrated as it is by masterly cuts, it should be one of the most popular books.—*Christian Standard* (Cincinnati).

For realistic conception and life-like delineation of character, it is not excelled by any American story.—*Methodist*.

Some passages in it, for life-like delineation and the simple, artless beauty which constitute the highest perfection of story-writing, are equal to some of the very best passages in Dickens.—*Religious Telescope*.

PRICE, POST-PAID.....\$1.25.

The End of the World.

A LOVE STORY.

By EDWARD EGGLESTON,

Author of "The Hoosier School-Master."

WITH

Thirty-two Fine Illustrations.

NOTICES BY THE PRESS.

The personages who figure in this story are, with one exception, country people—such men and women as Wordsworth loved to study. It is not every man, whatever may be his talents, that can safely enter this sphere of literary labor. To be successful in it, he must possess exceptional qualities; but for those who know how to find it, here there is gold of the purest, richest kind. In such a work, however, there is no convenient place where mediocrity can rest; there is nothing but absolute failure or absolute success. And Mr. Eggleston has succeeded. His power lies in the delineation of character. The plot is ingenious and natural, the incidents are managed with great skill, and there are many descriptive passages of singular force and beauty. But the strongest impression left on the reader's mind as he closes the volume is that he has been in the company of very interesting men and women, and has made a number of new and valuable acquaintances.—*The Albion*, New York.

Price, Post-paid, \$1.50.

The Mystery

OF

Metropolisville,

By EDWARD EGGLESTON,

Author of "The Hoosier School-Master," "The End of the World," etc.

FINELY ILLUSTRATED.

CONTENTS.

Preface.—Words Beforehand. Chapter 1. The Autocrat of the Stage-Coach.—2. The Sod Tavern.—3. Land and Love.—4. Albert and Katy.—5. Corner-Lots.—6. Little Katy's Lover.—7. Catching and Getting Caught.—8. Isabel Marlay.—9. Lovers and Lovers.—10. Plausaby, Esq., takes a Fatherly Interest.—11. About Several Things.—12. An Episode.—13. A Shelter.—14. The Inhabitant.—15. An Episode.—16. The Return.—17. Sawney and his Old Love.—18. A Collision.—19. Standing Guard in Vain.—20. Sawney and Westcott.—21. Rowing.—22. Sailing.—23. Sinking.—24. Dragging.—25. Afterwards.—26. The Mystery.—27. The Arrest.—28. The Tempter.—29. The Trial.—30. The Penitentiary.—31. Mr. Lurton.—32. A Confession.—33. Death.—34. Mr. Lurton's Courtship.—35. Unbarred.—36. Isabel.—37. The Last.—Words Afterwards.

ILLUSTRATIONS.—By FRANK BEARD.

His Unselfish Love found a Melancholy Recompense.—The Superior Being.—Mr. Minorkey and the Fat Gentleman.—Plausaby sells Lots.—"By George! He! he! he!"—Mrs. Plausaby.—The Inhabitant.—A Pinch of Snuff.—Mrs. Ferret.—One Savage Blow full in the Face.—"What on Airth's the Matter?"—The Editor of "The Windmill."—"Git up and Foller!"

Price Postpaid - - - - \$1 50

Either of the above books sent post-paid on receipt of price, by the

ORANGE JUDD COMPANY,
245 BROADWAY, NEW YORK.



THE PRACTICAL POULTRY KEEPER.

A COMPLETE AND STANDARD GUIDE TO THE

MANAGEMENT OF POULTRY,

FOR DOMESTIC USE, THE MARKETS, OR EXHIBITION.

Beautifully Illustrated.

By L. WRIGHT.

NOTICES BY THE PRESS.

This book is a valuable manual for everybody who feeds chickens or sells eggs. It suits at once the plain poulterer who must make the business pay, and the chicken fancier whose taste is for gay plumage, and strange, bright birds. The most valuable portion is the first section, extending through fifty-five pages. These were written with the intention of producing a manual so plain, minute, and practical, that any one could, by using it as a guide, with no previous experience with poultry, become at once successful in producing eggs, young chickens, and fat fowls for market. The author has not missed his aim. The middle parts of Mr. Wright's Manual are taken up with minute directions for making show fowls for Fairs, a nice discussion of the good and bad points of the different breeds, and a brief sketch of such fancy stock as peafowl, pheasants, and water-fowl. Then follows a section on artificial hatching, and another, worth special attention, on large poultry yards.... A study of Mr. Wright's book will convince any farmer's wife that all she needs is to give a half hour each day, of intelligent and sagacious attention to her poultry, in order to obtain from them, not tape, and knitting needles, and buttons, and nutmegs merely, but the family supplies of sugar, shoes, and cloth. *New York Tribune*.

It is the most complete and valuable work on the matters of which it treats yet published. It will be found a plain and sufficient guide to any one in any circumstances likely to occur, and is illustrated with elegant engravings of many breeds of fowls. *Farmers' Cabinet*.

This is a reprint, with numerous wood engravings, of an English book, the object of which is to convey in plain language a great deal of practical information about the breeding and management of poultry, whether for domestic use, the markets, or exhibition.... The book is eminently practical, and we recommend it to farmers and others interested in breeding and selling poultry. *Philadelphia Press*.

It is a handsome volume, brought out in the best style, and enriched with nearly fifty illustrations. It is evidently the fruit of a thorough, practical experience and knowledge of fowls, and will be found a plain and sufficient guide in all the practical details of poultry management as a profitable business. *United Presbyterian*.

The subject is treated fully and ably by an experienced hand, and the volume will doubtless find a large sale among the growing class of poultry fanciers. It is embellished with numerous illustrative engravings. *New York Observer*.

The author has called to his aid all who were experienced in the subject whereof he writes, and the consequence is a volume of more than ordinary thoroughness and exhaustiveness. *Rochester Democrat*.

The book is a complete and standard guide to the management of poultry for domestic use, the market, and for exhibition. *Watchman and Reflector*.

PRICE, POST-PAID, \$2.00.

ORANGE JUDD CO.,
245 Broadway, New York.

THE BREECH-LOADER.

By "GLOAN."

FULLY ILLUSTRATED.

CONTENTS.

Of the Breech-Loading Gun. How to Load the Breech-Loader. Names of the Parts of the Breech-Loading Gun. Powder for the Breech-Loader. The Barrels of the Breech-Loader. The New Explosives. Shot for the Breech-Loader. Wadding for the Breech-Loader. How Breech-Loaders are Made. Concentrators for Breech-Loaders. The Pin and Central Fire Breech-Loaders. Metal and Paper Cartridges. The Fit of the Breech-Loading Gun. The Locks of a Breech-Loading Gun. To Take a Gun Lock to Pieces. Names of the Parts of the Gun Locks. To Take Apart and Put Together a Breech-Loader. Field Philosophy.

Price, post-paid, Two DOLLARS.

Window Gardening.

By HENRY T. WILLIAMS,

EDITOR OF THE HORTICULTURAL, AND HORTICULTURAL EDITOR OF THE NEW YORK INDEPENDENT.

FINELY ILLUSTRATED.

There can be no more attractive ornaments about the house than beautiful flowers, and Mr. Williams's book tells exactly how they may be arranged, and what flowers to plant. It is seldom that a book is published on such subjects containing so much practical information. *The World* (New York).

CONTENTS:

Chap. 1.—Window Gardening—Its Pleasures—Increase in Popular Taste—Reining Influences. Chap. 2.—Location and Designs for Window Gardens. Chap. 3.—General Management of Window Gardens. Chap. 4.—Special Care of Window Gardens. Chap. 5.—Insects, and how to Kill them. Chap. 6.—Propagation from Seeds, Cuttings, etc. Chap. 7.—Propagating Boxes, Heating Cases, etc. Chap. 8.—Window Pots, Boxes, Plant Stands. Chap. 9.—Conservatories and Greenhouses. Chap. 10.—Hanging Baskets. Chap. 11.—The Ivy for Decorative Purposes. Chap. 12.—Climbing Vines, Balcony Gardening. Chap. 13.—Bulbs. Chap. 14.—Ferneries, Wardian Cases, Fern Decorations. Chap. 15.—The Camellia. Chap. 16.—The Rose. Chap. 17.—The Fuchsia, Myrtle. Chap. 18.—The Heliotrope. Chap. 19.—The Geranium. Chap. 20.—The Oleander, Bouvardia. Chap. 21.—Verbenas, Petunias, etc. Chap. 22.—The Mignonette, Cinerarias. Chap. 23.—Carnations. Chap. 24.—Alpine Plants. Chap. 25.—Miscellaneous Plants. Chap. 26.—Parlor Decorations.

Price, post-paid, \$1.50

Either of the above books sent post-paid on receipt of price by

ORANGE JUDD COMPANY,
245 BROADWAY, NEW YORK.

A Trochar for Cattle-Men.

In June of 1873 we gave illustrations of a Trochar and Cannula to be used in ringing a bull, and on page 13 (January) and page 97 (March) of last year's volume we described the use of this apparatus in relieving hoven in cattle. These articles have brought out a large demand for Trochars, and failing to find just the right kind among the makers of surgical implements, we have induced an establishment to undertake their manufacture. We give herewith a small engraving of the Trochar. These articles are now in the trade, and may be had of most dealers in agricultural implements. Those who can not get them from dealers can receive them from this office, post-paid, for \$1.00.

Address ORANGE JUDD COMPANY,
245 BROADWAY, NEW YORK.

A Copper Bull-Ring,

2 1/4 inches in diameter, of the most approved pattern, with screw-driver for putting it together, will be sent, post-paid, on receipt of \$1.00.

Address ORANGE JUDD COMPANY,
245 BROADWAY, NEW YORK.

CUMMINGS' Architectural Details.

CONTAINING

387 Designs and 967 Illustrations Of the Various Parts Needed in the Construction of Buildings, Public and Private, both for the City and Country.

ALSO, PLANS AND ELEVATIONS OF

Houses, Stores, Cottages, and Other Buildings.

BY

M. F. CUMMINGS, A.M., Architect,

Associate Author of "Architecture, by Cummings & Miller," and "Modern American Architecture, by Cummings & Miller."

Nearly eight years ago, the author of this work, in connection with Mr. C. C. Miller, architect, published a work on architectural details, which, as soon as it was presented to the architects, carpenters, and builders of the country, met with a rapid sale; and, judging from the number of editions through which it has passed, and the great circulation reached, it must have met the approval of those most interested in practical architectural works, and must have filled, in a measure, a want before unsupplied.

The success of that book has induced the author to publish a second one, which is now presented to the public, and in it will be found an extensive collection of designs illustrating the features which go to make up structures such as are needed to meet the wants of the American people.

What has been aimed at is this: To present a mass of architectural details, easy of construction, pleasing in form, and generally of an inexpensive character, and all so designed that a great variety of selections may be made from them, which, when combined in a building, will produce a harmonious whole; and it is believed by the author that this work will be found to be of value, and that its design is practicable, for there are hundreds of towns and villages, in all the States of the Union, in which the wants of the people continually demand the erection of buildings, largely of wood, and which in the hands of the builder and workman may be made elegant and pleasing in all their features, provided they have at hand a guide such as this book is intended to be.

Royal Quarto. Price, post-paid, \$10.

ORANGE JUDD COMPANY, 245 BROADWAY, NEW YORK.

PEAR CULTURE

FOR PROFIT.

By P. T. QUINN,

PRACTICAL HORTICULTURIST.

ILLUSTRATED.

Contents:

Chap. I. Varieties.	Chap. IX. Varieties to Plant.
" II. Aspect.	" X. Pruning.
" III. Preparation of the Soil.	" XI. Manuring and Mulching.
" IV. Distance Apart in Planting.	" XII. Gathering Fruit.
" V. Dwarfs and Standards.	" XIII. Marketing Pears.
" VI. Planting-Time.	" XIV. Profits.
" VII. Planting.	" XV. Propagation, etc.
" VIII. Nursery Trees.	" XVI. Practical Suggestions.
	" XVII. Orchard Record.

PRICE, POST-PAID.....\$1.00

ORANGE JUDD COMPANY, 245 BROADWAY, NEW YORK.

JOHN ANDROSS.

BY

REBECCA HARDING DAVIS,

Author of "Life in the Iron Mills," "Dallas Calbraith," etc., etc.

ILLUSTRATED.

NOTICES BY THE PRESS.

The story is of intense interest, and holds the reader from its commencement to its close, and gives much food for thought regarding the workings of political rings and government frauds in our large cities.—Post, Salem, Mass.

The characters and their work are strongly but no doubt truthfully drawn. Aside from its literary merit, the book deserves credit for calling attention to a crying shame of our time.—Christian Advocate, Pittsburgh, Pa.

It will at once enchain the attention of the reader, and prove vigorously and skillfully written, by this among the foremost novel writers of America.—Commonwealth, Boston, Mass.

Of a story of Mrs. Davis it is hardly necessary to say that it holds the reader's absorbed attention from beginning to end. Though the interest of the plot is very considerable, it is subordinate to the higher interest of the description and development of character. There is a great deal of very life-like painting of people and manners.—Christian Union, New York.

The characters are well drawn, the incidents are full of interest, and the plot sustained with consistency and power.—Daily Spy, Worcester, Mass.

We are constantly struck with the out-cropping of the one golden thread that holds all her writings together, and never fails to shine through the web of whatever plot she weaves about it—that singleness of point and moral more characteristic of her writings than of any other we know of, and which is, broadly stated, a self-sacrificing devotion to duty.—Daily Standard, Bridgeport, Ct.

Her hero is a man entangled by the great Ring of Pennsylvania, who is sent by this corporation to the State Senate with a hold of criminality to keep him in hand, who even then attempts to break loose and join the party of honesty, but is at the crisis brought in check again by the Ring, with the still more potent motive of love. . . . The plot is very well wrought, and the denouement is powerfully conceived and managed.—New York Evening Mail.

Price, Post-paid, \$1.50.

ORANGE JUDD COMPANY, 245 BROADWAY, NEW YORK.

PRETTY MRS. GASTON, AND OTHER STORIES.

BY

J. ESTEN COOKE,

Author of "The Virginia Comedians," "Dr. Van Dyke," "Surry of Eagle's Nest," etc.

NOTICES BY THE PRESS.

The narrative is ever animated, and here and there touched with warm, tender, yet natural emotion.—College Courier, New Haven, Conn.

The principal figure of the story, the pretty widow Mrs. Gaston, is well drawn and attractive, and the author has displayed in the treatment of this character much care and ingenuity.—Boston Traveller.

The style of Mr. Cooke's writings is smooth and fascinating, and whoever commences the perusal of them will never regret the undertaking.—Westfield News Letter.

A romance with a most delightful complication of matrimonial purposes, as well as having a villain, forger, gambler and detective to assist in the action.—Boston Post.

The plot of the principal story is finely wrought out, full of incident, and there is a sort of fascination about the style, which claims the attention of the reader until the close.—Salem Gazette.

A very lively and amusing book.—Country Gentleman.

The story is written in popular style—a little plot, a little mystery, a little love—and is sure to attract a large number of readers.—Reading (Pa.) Eagle.

Price, Post-paid, . . . \$1.50.

ORANGE JUDD COMPANY, 245 BROADWAY, NEW YORK.

Beckwith Sewing Machines

\$12 and \$20.

We have offered as a Premium, and also for sale, for more than a year past, the Beckwith Sewing Machine, which has been fully described in previous numbers of this paper. We have already given and sold more than one thousand of these machines, and testimonials of satisfaction have come from every quarter.

We still offer the Beckwith Sewing Machine, Improved, price \$12. A new and very simple braiding-foot has been made, by which a child can sew on braid without the least trouble, following any desired pattern with ease; also a new arm, spiral spring and lever for raising the presser-foot, all of which are now set in a position that leaves the needle free to be threaded. The joint is much enlarged, and the machine is otherwise greatly strengthened and improved. The use of the braider-foot alone will be valued more than the cost of the machine.

Each of these machines is put in a neat, compact box, with hemmer and guide, oil-can with oil, thread, different-sized needles, etc., with full Printed Directions for using. On receipt of \$12 we will send one of these machines to any address, expressage to be paid by the purchaser.

The Machine as a Premium.

We will give one of these \$12 machines to any one who will collect and forward eight subscribers for *Hearth and Home* one year at \$3 each; or sixteen subscribers to *American Agriculturist* for one year, at \$1.50 each, expressage on the machine to be paid by the recipient of it.

THE BECKWITH PORTABLE FAMILY SEWING MACHINE.

PRICE \$20.

Enlarged and Improved. Its Weight is 7 Pounds.

While we continue the offer of the Improved \$12 Machine as heretofore, we now offer the new

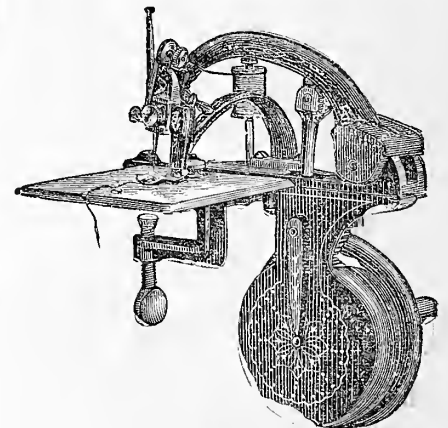

PORTABLE FAMILY MACHINE,

price \$20, which comprises all the excellencies of the former, with many valuable improvements. Its size and power are increased, and its capacity thus very much enlarged, without impairing its portability. There have been added cam and eccentric movement, a balance-wheel, and also an oscillating needle-clamp, by which the length of stitch can with the greatest ease be changed to the finest shade of variation without touching the needle.

To any one sending us \$20, we will send one of the Machines (packed in a neat, portable case, with handle to carry it easily), expressage to be paid by purchaser.

The Machine as a Premium.

We will give one of these \$20 Machines to any one who will collect and forward to us Fifteen Subscribers to *Hearth and Home* for one year at \$3 each, or Thirty Subscribers to *American Agriculturist* for one year at \$1.50 each, or One Hundred at \$1 each, expressage on the Machine to be paid by the recipient of it.

Almost any lady can readily secure the small number of subscribers required to get either the \$12 or the \$20 Machine as described above; or some friend can thus obtain it for her as a present.

ORANGE JUDD COMPANY, 245 BROADWAY, NEW YORK.

DO GOOD

AND

MAKE

MONEY.

The Publishers of American Agriculturist and HEARTH AND HOME take pleasure in presenting in the adjoining Table, their new general Premium List for 1874. The Premiums which they have offered in past years have engaged the attention of a very large number of persons of all ages and both sexes. Many thousands have secured Premiums, and very many of these, who at first had small hopes of success, have been themselves astonished at the ease with which they have raised large clubs and secured valuable Premiums.

Here is pleasant and profitable work for all. Any one who wishes to do good and make money, can do both by going to work as here invited by the publishers of these two most valuable journals, American Agriculturist and HEARTH AND HOME. You need only to show specimens of the papers, promise the beautiful Chromos, which are now ready for delivery, according to the publishers' offer, and forward your subscriptions. TRY IT.

Explanatory Notes.

N. B.

Read and carefully

Note the following Items: (a) All subscribers sent by one person commit, though from one or a dozen different Post-offices. But... (b) Tell us with each name or list of names sent, that it is for a premium.... (c) Send the names as fast as obtained, that the subscribers may begin to receive the paper at once. You can have any time, from now until July 1st, to fill up your list.... (d) Send the exact money with each list of names, so that there may be no confusion of money accounts.... (e) Old and new subscribers all count in premium clubs, but a portion, at least, should be new names; it is partly to get these that we offer premiums to canvassers.... (f) Specimen Numbers, etc., will be supplied free as needed by canvassers, but they should be used carefully and economically, and where they will tell.... (g) Remit money in Checks on New York Banks or Bankers, payable to order of Orange Judd Company, or send Post-office Money Orders. If neither of these is obtainable, Register Money Letters, affixing stamps both for the postage and registry; put in the money and seal the letter in the presence of the Post-master, and take his receipt for it. Money sent in any of the above ways is at our risk; otherwise it is not.

[In the following table is given the price of each article, and the number of subscribers required to get it free, at the regular rates, \$1.50 a year for American Agriculturist, and \$3.00 a year for Hearth and Home; also at the club rates of \$1 and \$2.50; also at the rates of \$4 a year for both papers together.] Description of Premiums sent free to applicants.

N. B.—In all Premium Clubs for either paper, TWO copies of American Agriculturist (English or German) at \$1.50 each, and ONE copy of Hearth and Home at \$3.00, will count exactly the same. So also two copies of American Agriculturist at \$1 each, and one copy of Hearth and Home at \$2.50, will count exactly the same. In this way Premium Clubs can be made up from the 2d and 4th columns, or from the 3d and 5th, or wholly from the 6th column.

Table of Premiums and Terms For American Agriculturist, and for Hearth and Home, for the Year 1874.

Open to all—No Competition.

Table with 6 columns: No., Names of Premium Articles, Price of Premiums, American Agriculturist only, and Hearth and Home only. Includes items like Moore's Floral Set, Gold Pen, Revolving Pencil, and various sewing machines.

Every Premium article is new and of the very best manufacture. No charge is made for packing or boxing any article in our Premium List. The Premiums, Nos. 2 to 8, 27 to 33, 55 to 78, and 81 to 93, inclusive, will each be delivered FREE of all charges, by mail or express (at the Post-office or express office nearest the recipient) to any place in the United States or Territories.—The other articles cost the recipient only the freight after leaving the manufactory of each, by any conveyance desired. Description of Premiums sent free to applicants.

"UP FOR REPAIRS,"

A Beautiful, New Picture for Every Subscriber to the

American Agriculturist

FOR 1874.

An exquisite Oil Painting by the celebrated American Painter, Mr. B. F. Reinhart, executed expressly for the American Agriculturist and entitled

"UP FOR REPAIRS,"

has been most successfully reproduced in Chromo by the well-known firm of Bencke & Scott. It is a picture of a scene in childhood, which many will recognize as what they have themselves witnessed or been actors in, and can not fail to please both old and young.

The Publishers will give this beautiful Chromo

To Every Subscriber

to this paper for the year 1874 received after this date, as detailed below. It is ready for immediate delivery at 245 Broadway, Free of Charge.

If to go by mail, 10 cents must be sent to cover cost of packing and postage. For 25 cents it will be Mounted, Varnished, Packed, and sent Post-paid.

N. B.—The Chromo will be delivered: At the Office, Unmounted, Free.

" " Mounted, 15 cents extra.

Sent by Mail, Unmounted, 10 cents extra.

" " Mounted, 25 cents extra.

We advise all to have them mounted before leaving the office, as in the large quantities we put up we are able to mount them for a quarter of the cost of doing it singly, and better than it can usually be done elsewhere.

The picture is designed for every subscriber upon the terms stated above, which please read carefully; and on these terms all are alike entitled to it, whether their names come singly at \$1.50 each, or in Clubs of Four for \$5, or Clubs of Ten at \$1.20 each, or in Clubs of Twenty or more at \$1 each. Subscribers in Premium Clubs will also thus be entitled to it.

N. B.—A few of the beautiful pictures entitled "MISCHIEF BREWING," which have been given to so large a number of subscribers, are still in stock, and, while any remain, subscribers to the American Agriculturist can have their choice between this and the new Chromo "UP FOR REPAIRS"; but the choice must be named at time of subscribing.

ORANGE JUDD COMPANY, 245 BROADWAY, NEW YORK.

BEAUTIFYING

COUNTRY HOMES.

AN ELEGANT QUARTO VOLUME.

By J. WEIDENMANN

PRICE, POST-PAID, \$15.00.

This magnificent work is illustrated not only with numerous fine wood-engravings, but also with seventeen full-page and seven double-page colored lithographs of places already improved. It embodies the results of a long practice in landscape architecture and rural adornment, and while its teachings are in accordance with the received rules of art, they are thoroughly practical in their character. It is one of the most elegant, and ought to prove one of the most useful works ever issued in the country. The work, both in its letter-press and colored lithographs, is beautifully printed, and it is elegantly bound in beveled boards.



Hussey's National Cottage Architecture.

New and Original Designs, Working Scale Drawings, and Details for all Styles of low-priced Houses, with Specifications and Cost. Just published. Royal quarto. Post-paid, \$6.

WOODWARD'S NATIONAL ARCHITECT. 1,000 WORKING DRAWINGS, Plans, Details, Specifications, and Estimates. TWELVE DOLLARS, post-paid.

MONCKTON'S NATIONAL STAIRBUIDER. SIX DOLLARS, post-paid.

MONCKTON'S NATIONAL CARPENTER and JOINER. SIX DOLLARS, post-paid.

Either of the above books sent post-paid on receipt of price by

Orange Judd Company, 245 Broadway, N. Y.

GREAT DEDUCTION. TEAS and COFFEES

At Wholesale Prices. Increased Facilities to Club Organizers. Send for New Price-List. THE GREAT AMERICAN TEA COMPANY, (P. O. Box 5643.) 31 and 33 Vesey St., New York.

WOOD, TABER & MORSE, Eaton, Madison Co., N. Y.

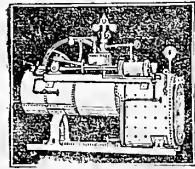

Steam-Engines, Portable, Stationary, and Agricultural.

Hundreds in use in Shops, Printing Rooms, Mills, Mines, and on Farms and Plantations for Grain Threshing, Food Cooking for Stock, Cotton Ginning, Sawing, etc. Circulars sent on application.

HO! FOR IOWA

HOMES, at \$3 and \$6 per acre, on long time. Over 1,500,000 acres Railroad Lands, free from mortgage, for sale by the Iowa Railroad Land Co., all on the C. & N. W. & Ill. Central Railway lines, in the middle region of Western Iowa, the richest farming belt in the West. Pure water abundant. No fever and ague. Send for a land guide. It costs nothing, and gives every needful information. Address JOHN B. CALHOUN, Land Commissioner, 90 Randolph Street, Chicago, or Cedar Rapids, Iowa.

Lovejoy's New Style GLASS CUTTER AND PUTTY KNIFE

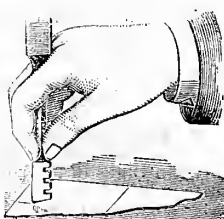

Cuts glass better than a diamond. Everybody should have one. Any child can use it. Sent to your address on receipt of 50 cents and stamp by

ALVAN L. LOVEJOY 229 Washington St., Boston, - - - Mass. Liberal discount made to dealers.

Joseph Gillott

STEEL PENS!

Sold by all Dealers. No. 91 JOHN ST., NEW YORK. HENRY HOE, Sole Agent. JOSEPH GILLOTT & SONS



BUILDING FELT. This water-proof material, resembling fine leather, is for outside work (no tar substances used) and inside, instead of plaster. Felt carpetings, etc. Send two 3-cent stamps for circular and samples. C. J. FAY, Camden, N. J.

CARPENTRY MADE EASY;

Or, The Science and Art of Framing, on a new and improved system. With specific instructions for Building Balloon Frames, Barn Frames, Mill Frames, Warehouses, Church Spires, etc. Comprising also a system of Bridge-building, with Bills, Estimates of Cost, and Valuable Tables. Illustrated by Thirty-eight Plates and near Two Hundred Figures.

By WILLIAM E. BELL, ARCHITECT AND PRACTICAL BUILDER. Price, Post-paid, - - - \$5.00. Address ORANGE JUDD COMPANY, 245 BROADWAY, NEW YORK.

JAS. T. ALLEN & CO.

Have manufactured a large stock of RICH AND MEDIUM PRICED FURNITURE

for the spring trade, which is now on exhibition and for sale, at wholesale and retail, at their extensive WAREROOMS, 185 & 187 CANAL ST., NEW YORK.

A M A C R I **P A T. D E P T.**

TRADE MARK. THE UNITED STATES OF AMERICA. TRADE MARK. THE UNITED STATES OF AMERICA. TRADE MARK. THE UNITED STATES OF AMERICA.

IMPORTANT TO INVENTORS. American Agriculturist PATENT DEPARTMENT

In compliance with the request of numerous inventors, we have organized a PATENT DEPARTMENT in connection with this office for the transaction of all business connected with

Securing Patents in the United States and foreign countries. The character for

Reliability which has been maintained by the AMERICAN AGRICULTURIST for more than thirty years will be carefully guarded in this as in other departments.

All Inventors desirous of procuring patents at moderate cost are invited to forward (express prepaid) a model of their invention, with a brief description of its working. The model should not exceed one cubic foot in dimension. Upon receipt of model an opinion as to patentability will be given free of charge.

Preliminary Examination at the Patent Office, to determine patentability, will be promptly made for a fee of \$5.

Litigation of Patents. The services of the best counsel have been secured to prosecute or protect before the U. S. Courts and the Patent Office the claims of those intrusting their business to this agency.

Specifications, drawings, engravings, models, and all other appliances furnished at moderate prices. In all dealings with this Department inventors may depend upon promptness, fidelity to their interests, and the best services which can be rendered by thorough experts. For full particulars, address

AMERICAN AGRICULTURIST PATENT DEPARTMENT, ORANGE JUDD COMPANY, 245 Broadway, New York.

JENNIE JUNE'S AMERICAN Cookery Book.

Containing upwards of twelve hundred choice and carefully tested recipes; embracing all the popular dishes, and the best results of modern science, reduced to a simple and practical form. Also, a chapter for invalids, for infants, one on Jewish cookery, and a variety of miscellaneous recipes of special value to house-keepers generally.

By Mrs. J. C. CROLY (Jennie June).

PRICE, POST-PAID, - - - \$1.75. Address ORANGE JUDD COMPANY, 245 BROADWAY, NEW YORK.

Tim Bunker Papers;

OR, YANKEE FARMING. BY TIMOTHY BUNKER, Esq., OF HOOKERTOWN, CONN.

WITH ILLUSTRATIONS BY HOPPIN.

CONTENTS.

- 1.—A Stroke of Economy.
- 2.—Ornamental Trees.
- 3.—Timothy Bunker, Esq.
- 4.—View of the Bird Law.
- 5.—Guano in the Hill.
- 6.—On Moss Bunkers.
- 7.—On subsoiling.
- 8.—Going to the Fair.
- 9.—In Tall Clover.
- 10.—On Horse Racing.
- 11.—At the Farmers' Club.
- 12.—On an Old Saw.
- 13.—Book Farming in Hookertown.
- 14.—Pasturing Cattle in Roads.
- 15.—The Weaker Brethren.
- 16.—Curing a Horse Pond.
- 17.—Domesticities at Tim Bunker's.
- 18.—Takes a Journey.
- 19.—On Farm Roads.
- 20.—A New Manure.
- 21.—Losing the Premium.
- 22.—A New Enterprise.
- 23.—Aking Tiles.
- 24.—The Clergy and Farming.
- 25.—Women Horse Racing.
- 26.—Beginning Life.
- 27.—An Apology for Tim Bunker.
- 28.—On County Fairs.
- 29.—At Home again.
- 30.—On Raising Boys.
- 31.—On Raising Girls.
- 32.—A New Case of the Black Art.
- 33.—A Letter from Neighbors.
- 34.—The Shadown Parsonage.
- 35.—Views of Dress.
- 36.—A Rustic Wedding.
- 37.—Saving a Sixpence.
- 38.—On Giving Land a Start.
- 39.—On Giving Boys a Start.
- 40.—A Tie in the Head.
- 41.—Lake Frink Sold.
- 42.—The New York Central Park.
- 43.—On Irrigation.
- 44.—Feeding with Oil-Meal.
- 45.—The Farmers' Club.
- 46.—On Bad Water.
- 47.—Cattle Disease.
- 48.—On Seed.
- 49.—On Breastworks in War.
- 50.—Lightning Rods.
- 51.—Buying a Farm.
- 52.—Top-dressing and Feeding Aftermath.
- 53.—Painting Buildings.
- 54.—The Value of Muck.
- 55.—On Family Horses.
- 56.—The Horn-sail.
- 57.—A Commentary on Roots.
- 58.—Stealing Fruit and Fences.
- 59.—The Cost of Pride.
- 60.—Swamps Turning Indian.
- 61.—Tim Bunker in his Garden.
- 62.—On Running Astern.
- 63.—On Extravagance.
- 64.—The Farmer's Old Age.
- 65.—On Sheep Traps.
- 66.—Old-Style Housekeeping.
- 67.—On Keeping a Wife Comfortable.
- 68.—Starting a Sugar Mill.
- 69.—Reasons against Tobacco.
- 70.—Trip to Washington.
- 71.—The Sanitary Commission.
- 72.—Raid among the Pickle Patches.
- 73.—Raid among the Pickle Patches.
- 74.—On Striking Ilc.
- 75.—Visit to Titus Oaks, Esq.
- 76.—The Pickle Fever in Hookertown.
- 77.—On Curing Pickles and Eating them.
- 78.—The Cotton Fever and Fair at On.
- 79.—The Cotton Fever and Emigration.
- 80.—The Food Question.
- 81.—On Jim Crow.
- 82.—The Eight-hour Law.
- 83.—Base Ball Clubs.
- 84.—The Rise of Real Estate.

SENT POST-PAID, - - - PRICE \$1.50.

ORANGE JUDD COMPANY, 245 BROADWAY, NEW YORK.

Every FARMER and STOCK RAISER, and EVERYBODY that keeps a HORSE, a COW, POULTRY, SHEEP, or SWINE—whether he lives in City, Town, or Country—wants the

Live Stock Journal.

Monthly. \$1.50 per year. In its 5th Volume. Beautifully illustrated. The best instructor upon every class of Live Stock. National—giving equal attention to the Stock Interests of every State. Treats, by practical writers, upon the Farm, the Dairy, Horses, Cattle, Sheep, Swine, Poultry, Bees, Fish, and their diseases. Specimen 10 cents. Address LIVE STOCK JOURNAL CO., Buffalo, N. Y.

WANTED.—The United States Life Insurance Company is now reorganizing its Agency Department, and is prepared to negotiate with gentlemen of business ability to act as Agents. Previous connection with the business is not considered necessary. Apply at the Home Office, 261 Broadway, New York. JOHN E. DEWITT, President.

BOOKS FOR FARMERS and OTHERS.

[Published and for sale by the Orange Judd Company, 245 Broadway, New York. Any of these books will be forwarded by mail, post-paid, on receipt of price.]

Table listing various books for farmers and others, including titles like 'American Cattle', 'Rural Architecture', 'Diseases of Domestic Animals', etc., with prices.

Table listing books for stock, including titles like 'Youatt and Martin on Cattle', 'Youatt on the Hog', 'Youatt on Sheep', and 'O. J. Co. keep in Stock the following Books:'.

WHOLESALE PRICE-LIST.

CRANDALL'S IMPROVED BUILDING - BLOCKS FOR CHILDREN.



BEAUTIFUL, AMUSING, INSTRUCTIVE.

CRANDALL'S Building - Blocks.

PRICE PER DOZEN BOXES.

- No. 1, \$12.00 (3 Dozen Boxes in a Case).
No. 3, \$ 6.00 (6 Dozen Boxes in a Case).
No. 4, \$ 6.00 (6 Dozen Boxes in a Case).

CRANDALL'S Masquerade - Blocks.

Price per Dozen Boxes \$6.00 (6 Dozen Boxes in a Case).

CRANDALL'S Expression - Blocks.

Price per Dozen Boxes, \$3.00 (12 Dozen Boxes in a Case).

Crاندall's Acrobats.

Price per Dozen Boxes, \$8.00 (6 Dozen Boxes in a Case).

CRANDALL'S Alphabet-Blocks,

Red White and Blue.

Price per Dozen Boxes, \$6.00 (6 Dozen Boxes in a Case).

Orders from the trade will be supplied on liberal terms.

MANUFACTURED BY

C. M. CRANDALL & CO.

ORANGE JUDD COMPANY,

Sole Agents,

245 BROADWAY, NEW YORK.

FRAMES

FOR THE CHROMOS.

We have made arrangements to supply frames to our subscribers who may desire them for the Chromos which are now being distributed. Many will no doubt avail themselves of this opportunity to place these beautiful pictures in handsome frames at moderate cost.

For American Agriculturist Chromo, "UP FOR REPAIRS," Or for Hearth and Home Chromo, "LOOK OUT!"

Table listing prices for different frame styles and sizes, such as 'Letter A. Neat Black-Walnut Frame, Gilt Band'.

For American Agriculturist Chromo, "MISCHIEF BREWING."

Table listing prices for different frame styles and sizes for 'Mischief Brewing'.

For Hearth and Home Chromo, "THE STRAWBERRY GIRL."

Table listing prices for different frame styles and sizes for 'The Strawberry Girl'.

Address orders, specifying by its letter or number the frame desired, and inclosing price, as above, to the ORANGE JUDD COMPANY, 245 BROADWAY, NEW YORK.

Rich Farming Lands

For Sale VERY CHEAP by the
Union Pacific Railroad Co.

MILLIONS OF ACRES

IN THE

STATE OF NEBRASKA,

AT PRICES RANGING FROM

\$2.00 to \$10.00 per Acre.

Five and Ten Years' Credit Given,
with Interest at Six per Cent.

**Convenient to Markets East
and West.**

The Lands of the Union Pacific Railroad Company are the odd numbered Sections for twenty miles on each side of the road. They are located in the valley of the Platte and its tributaries—a region widely celebrated for its beautiful scenery, rich, productive soil, and mild and healthful climate. The winters are short, and the atmosphere dry and invigorating. Epidemic diseases are unknown. The surface is undulating, covered with nutritious grasses, and watered with numerous clear running streams. All the productions of the Eastern and Middle States are grown with success. Wheat and Corn are the staples, and it is well adapted to the cultivation of Fruit. For Stock-raising, in all its branches, these lands are unsurpassed. The Union Pacific and its branch railroads furnish Market Facilities unequalled. Education is free. One-eighteenth part of the entire area forms a permanent endowment of the Public Schools. Good Society, Schools, Churches, Post-Offices, Mills, Stores, and other advantages of civilization are enjoyed.

The liberal provisions made for Education, the freedom from State debt, the rapidity with which this section is settling, the numerous towns and villages springing up, offering inducements to the merchant and mechanic, render this tract a most desirable location for the industrious man of limited means to secure a comfortable home, and acquire competence, independence, and position.

These lands are granted directly to the Railroad Company. The title given to the purchaser is absolute, in fee simple, free from incumbrances. They are sold in tracts of forty acres and upwards, giving the man of small means an equal chance with the capitalist to make a safe and profitable investment, one which can not be destroyed by fire or flood, a provision for future support, not affected by *revisions*, or liable to the fluctuations of stocks.

Full information in reference to particular localities will be furnished, good lands selected, and sales made, free of charge, for persons not desiring to incur the expense of coming to examine the lands in person.

ALSO,

THE PIONEER,

A handsome Illustrated paper, containing the HOMESTEAD LAW, mailed free to all parts of the world by addressing **O. F. DAVIS,**

Land Commissioner U. P. R. R. Co.,
OMAHA, NEB.

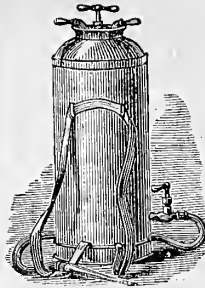

**BABCOCK
FIRE
Apparatus,**
ENGINES,
EXTINGUISHERS,
TRUCKS, etc.
BABCOCK MANUFACTURING CO.,
407 Broadway, New York,
83 Washington Street, Chicago.



FOR SALE BY DRUGGISTS.

ADVERTISERS should send to GEO. P. ROWELL & Co., 41 Park Row, N. Y., for their *Eighty-page Pamphlet*, containing lists of 3,000 newspapers and estimates, showing the cost of advertising. Mailed free to all applicants.

\$25 Per Day guaranteed using our **Well Auger** and Drills. Catalogue free. W. W. GILES, St. Louis, Mo.

NOW READY.

A New and Revised Edition of Peter Henderson's well-known Work, **Gardening for Profit.**

A Guide to the Successful Cultivation of the Market and Family Garden.

By **PETER HENDERSON.**

Finely Illustrated. Price, Post-paid, \$1.50.

The following voluntary notice of this work comes from a Western market gardener and shipper of vegetables, and is a specimen of similar testimony from very many quarters.

"March 23d, 1874.

"If this should go to Mr. Henderson, I would say that I believe the gardeners of this country would gladly hail another edition of 'Gardening for Profit,' at least, I thank him for that little work. Through its influence I left a paying manufacturing business and began to follow its teachings. This was three years ago. Now I have a market garden of thirty acres and 400 four feet sash, and enjoy myself as I never did before. Again I thank him."

Money IN THE GARDEN.

A VEGETABLE MANUAL,

PREPARED WITH A VIEW TO

ECONOMY AND PROFIT,

BY P. T. QUINN,

PRACTICAL HORTICULTURIST.

In this work the author aims to give, in a plain, practical style, instructions on three distinct although closely connected branches of gardening—the kitchen-garden, market-garden, and field culture; the only and sufficient credentials for the fitness of his undertaking being a successful practical experience for a term of years.

CONTENTS.

Chapter I. Money in the Garden.	Chapter VIII. Melons.
" II. Hot-beds.	" IX. Onions.
" III. Artichoke.	" X. Parsley.
" IV. Beans.	" XI. Radishes.
" V. Cabbages.	" XII. Salsify.
" VI. Egg-Plants.	" XIII. Tomatoes.
" VII. Lettuce.	" XIV. Forcing Houses.
Chapter XV. List of Seeds.	

PRICE, POST-PAID - - - - - \$1.50

Either of the above books sent post-paid on receipt of price by

ORANGE JUDD COMPANY,

245 BROADWAY, NEW YORK.

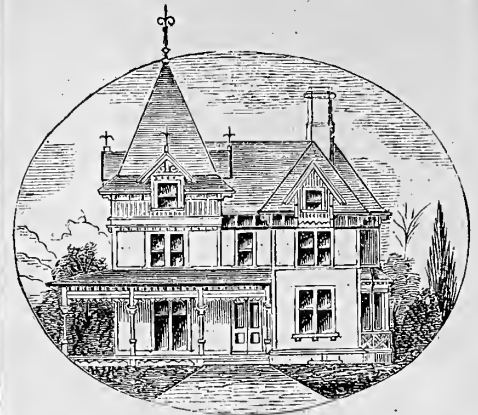

A Practical Book, one that Architects, Builders, and Carpenters can not afford to be without, entitled

DETAIL, COTTAGE, AND CONSTRUCTIVE ARCHITECTURE,

Containing **76 FULL PLATES**, 20 plates more than before offered in a similar work for Ten Dollars.

Published under the direction of **A. J. BICKNELL.**

Showing a great variety of Designs for Cornices, Brackets, Windows and Window Caps, Doors, Piazzas, Porches, Bay and Dormer Windows, Observatories, Towers, Chimney Tops, Balconies, Canopies, Scrolls, Gable and Sawed Ornaments, Fences, Stairs, Newels, Architraves, Mantels, Plaster Finish, etc., etc.; including Forty-five Perspectives, Elevations and Plans of Modern Designs for Cottages with Details, and Eighteen Elevations of Summer Houses, Villas, Seaside Cottages, and Country Houses, together with Fourteen Designs for Street and Store Fronts, with Inside Finish for Stores and Banks; also, Framing for Dwellings, Barns, Exhibition Buildings, Roofs, Bridges, etc., etc., making in all a Practical Book for Architects, Builders, Carpenters, and all who contemplate Building or Remodeling Wood, Stone, or Brick Buildings. One Large Quarto Volume, sent Free by Mail or Express, on receipt of Price. \$10.00.

Bicknell's Village Builder, And SUPPLEMENT.

THE VILLAGE BUILDER shows Elevations and Plans for Cottages, Villas, Suburban Residences, Farm Houses, Stables and Carriage-Houses, Store Fronts, School-Houses, Churches, Court-Houses, and a Model Jail. Also, Exterior and Interior Details for Public and Private Buildings, with approved Forms for Contracts and Specifications, containing fifty-five Plates, drawn to Scale, giving the Style and Cost of Building in different sections of the Country. *Revised Edition*, with three additional Plates, showing inside finish for Stores, Banks, and Insurance Offices, and two Elevations and Plans for low-priced Dwellings; also, a variety of Details added to several Plates. Quarto Volume, issued February 1, 1872. The SUPPLEMENT contains Twenty Plates, showing Eighteen Modern and Practical Designs for Country and Suburban Residences of moderate cost, with Elevations, Plans, Sections, and a Variety of Details, all Drawn to Scale. Also, a Full Set of Specifications, with Approved Form of Contract and Estimates of Cost. The Two Books in one Volume, price \$12.00. Parties desiring the Supplement only, will be supplied, post-paid, on receipt of \$5.00.

CARPENTERS' and BUILDERS' ASSISTANT, And Wood Workers' Guide,

By **L. D. GOULD**, Architect and Practical Builder.

Containing 23 Plates, fully described; also, tables of the strength of materials; technical terms used by carpenters, etc., etc. This work is intended to combine all the knowledge the workman requires to construct any design in carpentry, by a new and easy system of lines, reducing the science of construction to an agreeable and pleasant occupation, rather than an unpleasant task. One 8vo. volume, bound in cloth. Price. \$3.00.

ARCHITECTURE.

By **CUMMINGS & MILLER.**

A Practical Book on Architectural Details; containing over One Thousand Designs and Illustrations, showing the manner of constructing Cornices, Doorways, Porches, Windows, Verandas, Galleries, French Roofs, Observatories, Piazzas, Bay-Windows, Cast-stone Work, various styles of Modern Finish, and Street Fronts of Houses, Stores, etc., etc. One Large Quarto Volume. Price, post-paid. \$10.00.

Loth's Practical Stair-BUILDER.

A complete Treatise on the Art of Building Stairs and Hand-Rails. Designed for Carpenters, Builders, and Stair-Builders. Illustrated with Thirty Original Plates. By **C. EDWARD LOTH**, Professional Stair-BUILDER. One large Quarto Volume. Bound in Cloth. Price. \$10.00.

Address

ORANGE JUDD COMPANY,

245 BROADWAY, NEW YORK.

JULY, 1874.

AMERICAN

AGRICULTURIST

FOR THE FARM, GARDEN & HOUSEHOLD

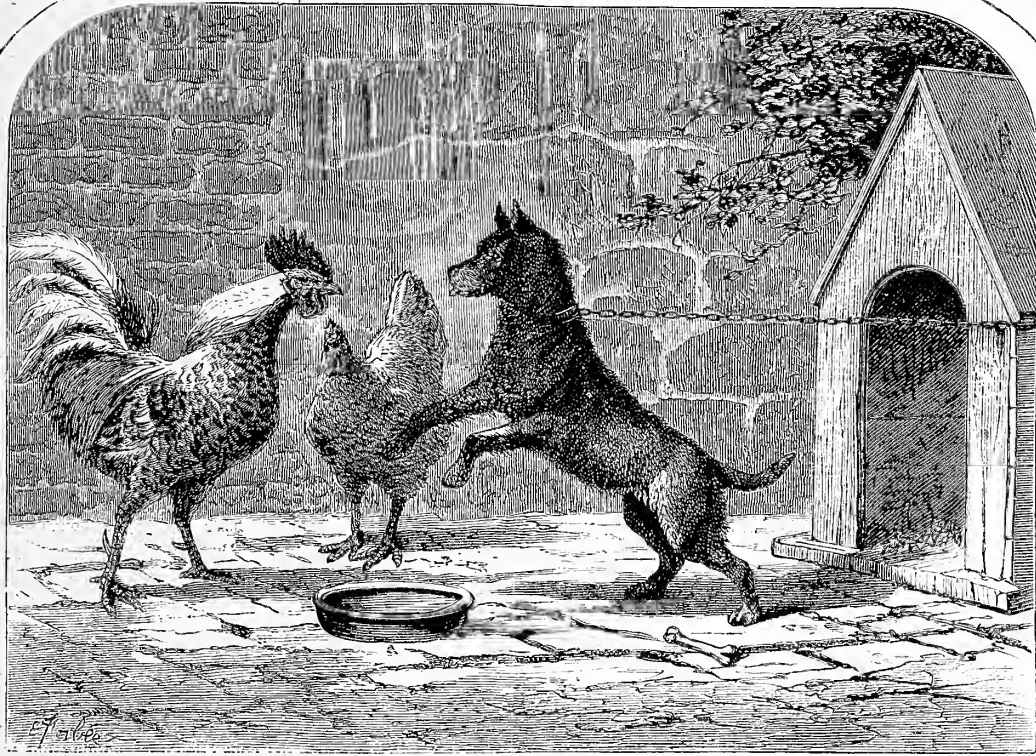

Vol. XXXIII

Number 7.

PUBLISHED BY THE
ORANGE JUDD COMPANY,
245 BROADWAY,
NEW YORK.



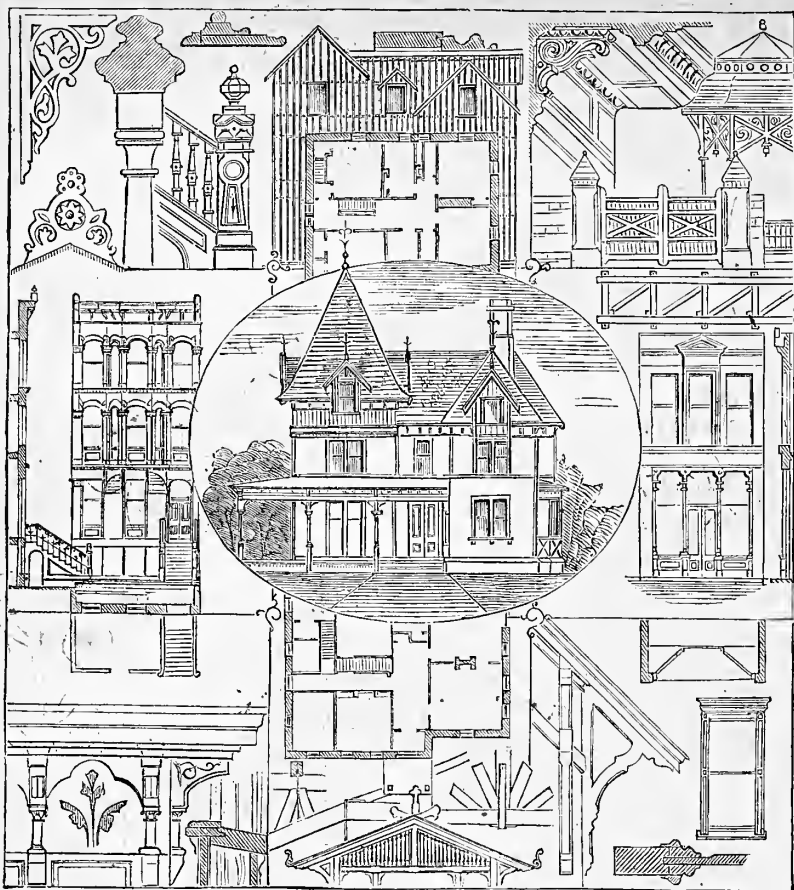

Detail, Cottage, and Constructive Architecture.

Containing 76 Full Plates, 20 Plates more than before offered in a similar work for Ten Dollars.
Published under the Direction of A. J. BICKNELL,

Showing a great variety of Designs for Cornices, Brackets, Windows and Window Caps, Doors, Piazzas, Porches, Bay and Dormer Windows, Observatories, Towers, Chimney Tops, Balconies, Canopies, Scrolls, Gable and Sawn Ornaments, Fences, Stairs, Newels, Architraves, Mantels, Plaster Finish, etc., etc.; including Forty-five Perspectives, Elevations and Plans of Modern Designs for Cottages with Details, and Eighteen Elevations of Summer Houses, Villas,

Seaside Cottages, and Country Houses, together with Fourteen Designs for Street and Store Fronts, with Inside Finish for Stores and Banks; also, Framing for Dwellings, Barns, Exhibition Buildings, Roofs, Bridges, etc., etc., making in all a Practical Book for Architects, Builders, Carpenters, and all who contemplate Building or Remodeling Wood, Stone, or Brick Buildings. One Large Quarto Volume, sent Free by Mail or Express, on receipt of Price.....\$10.00.

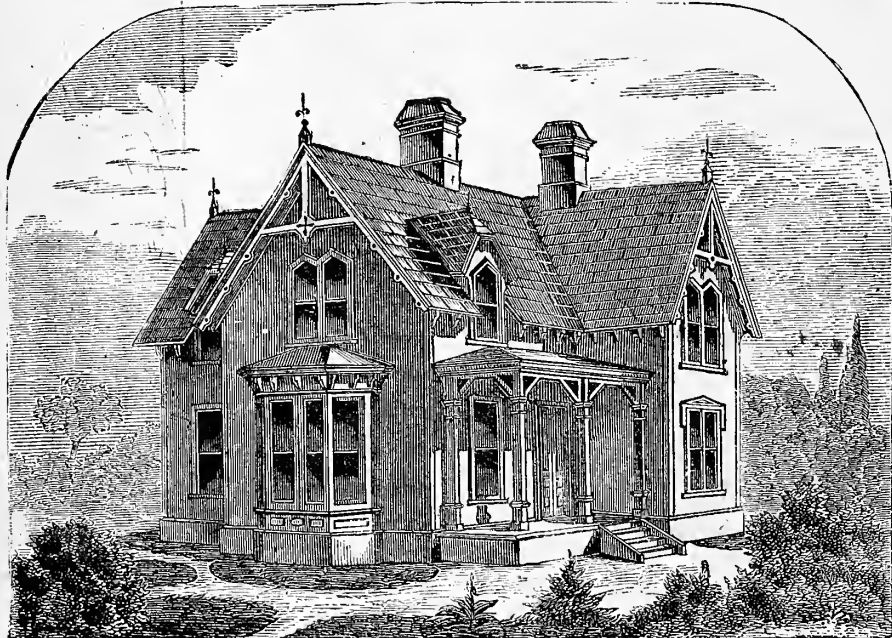

Bicknell's Village Builder, and Supplement.

THE VILLAGE BUILDER shows Elevations and Plans for Cottages, Villas, Suburban Residences, Farm Houses, Stables and Carriage-Houses, Store Fronts, School-Houses, Churches, Court-Houses, and a Model Jail. Also, Exterior and Interior Details for Public and Private Buildings, with approved Forms for Contracts and Specifications, all taking fifty-five Plates, drawn to Scale, giving the Style and Cost of Building in different sections of the Country. Revised Edition, with three additional Plates, showing inside finish for Stores, Banks, and Insurance Offices, and two Elevations and Plans for low-priced Dwellings, also, a variety

of Details added to several Plates. Quarto Volume, issued February 1, 1874. The SUPPLEMENT contains Twenty Plates, showing Eighteen Modern and Practical Designs for Country and Suburban Residences of moderate cost, with Elevations, Plans, Sections, and a Variety of Details, all Drawn to Scale. Also, a Full Set of Specifications, with Approved Form of Contract and Estimates of Cost. The Two Books in one Volume, price.....\$12.00.

Parties desiring the Supplement only, will be supplied, post-paid, on receipt of \$3.00.

Address, ORANGE JUDD COMPANY, 245 Broadway, New York.

Herald of Health.

This monthly is devoted to the culture of the body and mind; to rearing healthy and beautiful children; to the recovery of health without drugs; to the improvement of the physique; and to showing people how to live so as to be healthy, happy, and make the most of life. The Scientific American says: "It contains more sensible articles than any monthly that comes to our sanctum." \$2.00 a year, with a premium of the complete works of Shakespeare, in one volume of over 1,000 pages and 36 illustrations.
WOOD & HOLBROOK, 13 and 15 Light St., New York.

ENGLISH CHANNEL LADIES careful of their feet always wear ENGLISH CHANNEL Shoes, and buy none other. A dark line around the sole near the edge shows where the channel is cut. No more ragged soles. Make your dealer get them for you.

INVENTORS Who wish to secure PATENTS should write to MUNN & CO., 37 Park Row, New York, for Advice and Pamphlet, 108 pages, FREE.

A New and Revised Edition of Peter Henderson's well-known Work, Gardening for Profit.

A Guide to the Successful Cultivation of the Market and Family Garden.
By PETER HENDERSON.
Finely Illustrated. Price, Post-paid, \$1.50.

The success of this book has probably not been equaled by that of any horticultural work of the present day. Its popularity is due to the fact that it tells just what people wish to know—the way in which the author made money by gardening—and puts in a plain, striking light all the requisites to success. The writer was not afraid to have people know that he cultivated his land for profit, and, more than that, he was quite willing that all should know and practice. If they chose, the very processes which he had found most conducive to the desired end. The late Horace Greeley said of this book: "There are marvels of transformation and rapid reproduction recorded therein, which might well shame the dull fancy of the author of Aladdin or of Kaloolah. There is no theory about it; a man who has made himself rich by market-gardening plainly tells our young men how they can get rich as easily as he did, and without wandering to California or Montana for it either." And tens of thousands who have read and profited by the work could give similar testimony. It is unquestionably the most thorough and the best book of its kind that has yet come from the hand of an American author. In the revised edition several new chapters will be found, and in the selection of varieties much has been changed, though the plan of the work is the same as before.

The following is a specimen of hundreds of letters that have been received concerning this work.

"I was an early purchaser of 'Gardening for Profit,' a reading of which made the possession of 'Practical Floriculture' a necessity. I sincerely thank the writer for giving us non-professionals what we have so long needed—some plain common-sense directions for our assistance—and for having exploded some outrageous humbugs which have been perpetuated in all previous works on gardening and floriculture from time immemorial, tending to produce the conviction that nothing but professional skill could raise a vegetable or flower. LUTHER NEWCOMB, Montpelier, Vt. May 4, 1873.

The following voluntary notice of this book comes from a Western market gardener and shipper of vegetables, and is a specimen of similar testimony from very many quarters.

"March 23d, 1874.
"If this should go to Mr. Henderson, I would say that I believe the gardeners of this country would gladly hail another edition of 'Gardening for Profit;' at least, I thank him for that little work. Through its influence I left a paying manufacturing business, and began to follow its teachings. This was three years ago. Now I have a market garden of thirty acres and 400 four-foot sash, and enjoy myself as I never did before. Again I thank him."

ORANGE JUDD COMPANY,
245 BROADWAY, NEW YORK

ADVERTISING RATES. American Agriculturist. ENGLISH EDITION.

Inside Pages, \$1.50 per line (agate), each insertion.
Open Pages (open without cutting), \$2 per line.
Last Page, and 2d and 3d Cover Pages—\$2.50 per line.
Page next to Reading and Last Cover Page—\$3.00 per line.
No advertisement inserted for less than \$5.00.

GERMAN EDITION.
Inside Pages, 25 cents per line, each insertion.
Business Notices and Last Page, 40 cents per line.
No advertisement inserted for less than \$1.00.

No Advertisement of Medicines or Humbugs received.
Address all orders to

ORANGE JUDD COMPANY,
245 BROADWAY, NEW YORK.

AMERICAN AGRICULTURIST

FOR THE

Farm, Garden, and Household.

"AGRICULTURE IS THE MOST HEALTHFUL, MOST USEFUL, AND MOST NOBLE EMPLOYMENT OF MAN."—WASHINGTON.

ORANGE JUDD COMPANY,
PUBLISHERS AND PROPRIETORS.
Office, 245 BROADWAY.

ESTABLISHED IN 1842.

Published also in German at \$1.50 a Year.

{ \$1.50 PER ANNUM, IN ADVANCE.
SINGLE NUMBER, 15 CENTS.
{ Copies for \$5; 10 for \$12; 20 or more, \$1 each.

Entered according to Act of Congress, in June, 1874, by the ORANGE JUDD COMPANY, at the Office of the Librarian of Congress, at Washington.

VOLUME XXXIII.—No. 7.

NEW YORK, JULY, 1874.

NEW SERIES—No. 330.

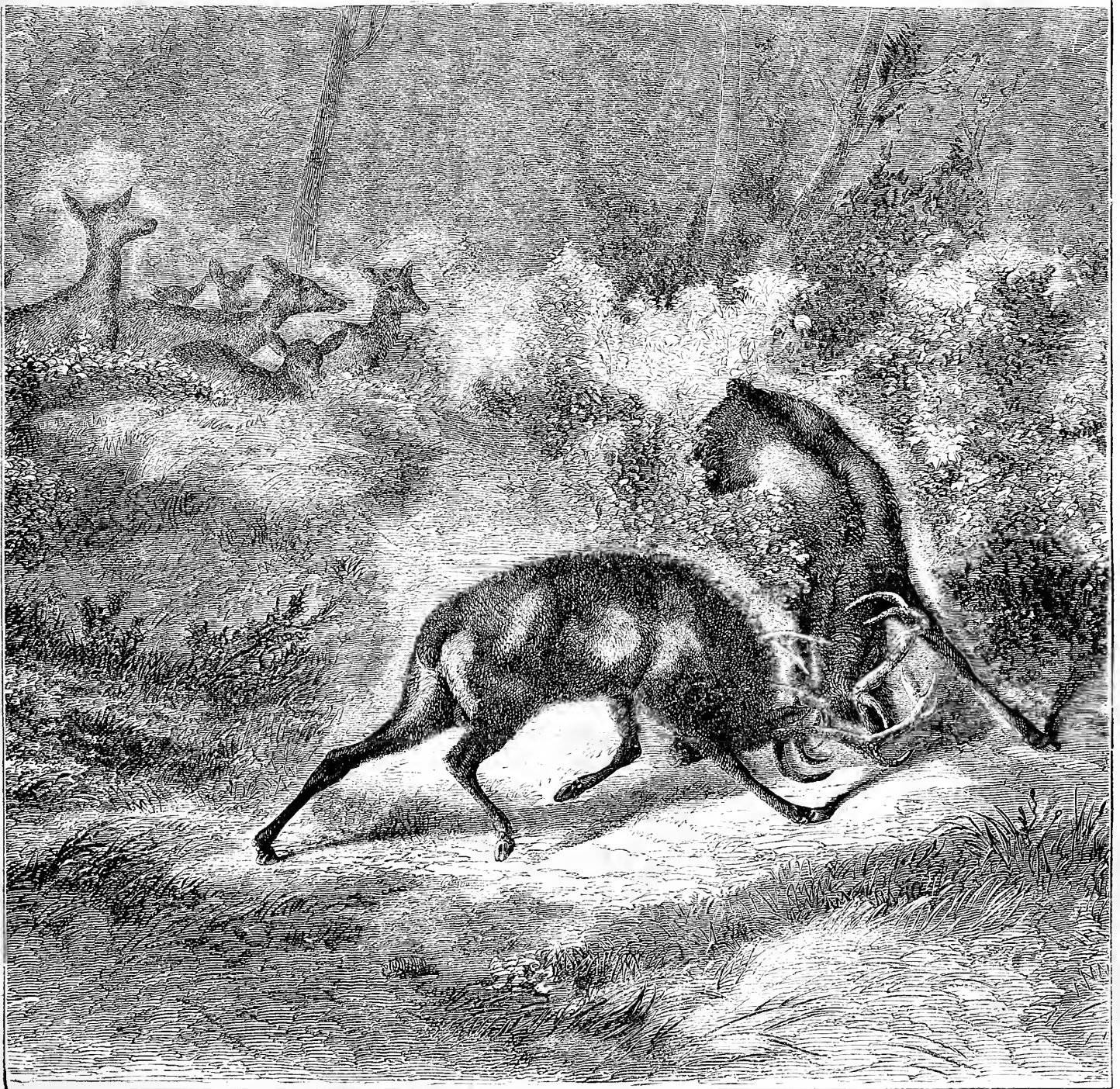

[COPYRIGHT SECURED.]

THE COMBAT.—*Drawn and Engraved for the American Agriculturist.*

No animal presents greater contrasts than does the male deer at different seasons. In winter, after his horns have fallen, and in spring, while waiting for them to grow again, the buck presents a very different appearance from the same animal in autumn, when, with wide-spread antlers, and courageous bearing,

he is ready to do battle with his rival. At this season the bucks roam the forest in search of the does, and when two meet, a battle is likely to ensue. In these contests the horns of the bucks become sometimes so interlocked, that it is impossible for the animals to disengage, and death by starvation must follow. In the wilds

of Texas, we have frequently met with pairs of skulls with the horns thus entangled. When we consider that the horns will be shed naturally in a few months, the strength with which they hold to the skull is astonishing. Even the horns of three animals have been found fastened together, with the skulls attached.

Contents for July, 1874.

Alkali Lands, Cure of... 258
Apple-Tree Borer... 261
Binders for Sheaves... 4 Illustrations... 259
Books, Herd... 259
Boys and Girls' Columns—Key of the Bastille—Mr. Crandall's Acrobats—Sunrise—Bas-relief—Bad Writers—Anut Sue's Puzzle-Box—Gulliver in Brobdignag... 2 Illustrations... 267, 268
Bee Notes—Advice to Beginners... 249
Cabbages as a Field Crop... 250
Carriage and Pigeon House... 3 Illustrations... 251
Cattle, Dutch or Holstein... 2 Illustrations... 253
Chimney, How to Build a... Illustrated... 257
Combat, The... Illustrated... 241
Daisy, European... 262
Farm Work for July... 242
Ferns and Fern Collecting... 263
Flower Garden and Lawn in July... 244
Fruit Garden in July... 243
Grain, Grading in New York... 258
Greenhouse and Window Plants in July... 244
Household Department—Clothes-Line Reel—French Cream Cake—Atrocity of Feather Beds—Honee Topics—What Shall we have for Breakfast—Pudding Sauce—Lemon Custard... 2 Illustrations... 265, 266
Kitchen Garden in July... 243
Lolling of the Tongue... 2 Illustrations... 252
Long Moss... Illustrated... 261
Market Reports... 244
Milkweed, Four-leaved... Illustrated... 264
Muck, Getting out Swamp... 3 Illustrations... 255
Natural Pastures... 252
Ogden Farm Papers, No. 53—Draining—Jersey Cattle—Haying... 250, 251
Orchard and Nursery in July... 243
Ox-Yoke, An Improved... 2 Illustrations... 256
Pickles... 262
Plows, Draft Irons for... 2 Illustrations... 257
Roads and Road Making... 3 Illustrations... 259
Roses, How to Propagate from Cuttings... 262
Sheep as a Cleansing Crop... 258
Shorthorns, Sale of... 249, 259
Stable, Prairie... 4 Illustrations... 256
Swindling by Mail... 249
Walks and Talks on the Farm, No. 127—Crops—Fruit—Pigs—Wheat straw—Sheep—Steamer... 254, 255
Steel Bars for Bells... Illustrated... 255
Yellow-root, Shrub... Illustrated... 264

INDEX TO "BASKET," OR SHORTER ARTICLES.

"Alfalfa"... 247
B. K. Bliss & Sons' Removal... 246
Bees... 248
Blood Diseases in Stock... 248
Borers, Peach... 248
Buckwheat for Cows... 247
Butter from Sweet Cream... 247
Butter, Packing... 247
Cheat or Chess... 248
Clover and Timothy, Sowing... 247
Colt, Diarrhea in... 248
Corn, Shelled or in Ear... 247
Corn, Value in Nebraska... 248
Crops, Culling... 247
Crops for Green Manure... 247
Crops, Soiling... 247
Cud, Loss of... 247
Dairy in the North West... 248
Dairy Items... 248
Disease of the Lungs... 247
Draining "Sticky" Land... 247
Eggs, Double-Yolked... 247
"Esquire"... 247
Exportation of Live Cattle... 247
Farmers, Bankrupt... 247
Farmers' Conventions... 247
Feed for Early Spring... 247
Forest Fires... 247
Grape Scissors... 248
Guano, Recent Discovery of... 248
Health of Farmers... 249
Hearth and Home, Sale of... 245
Hedge Rows, Breaking... 248
Hogs, Poland China... 247
Hogs, Time to Market... 247
Holding On... 247
Horn All... 247
Horses, Sale of Thoroughbred... 246
Horticultural Wks, Hibberds'... 246
Horticulturists, Death of... 245
Humbings, Sundry... 245
Imports and Exports... 248
Lambs, Disease Amongst... 248
"Lock-Out," English... 246
Manure for Clay Soil... 247
Mares, Old Brood... 248
Meats, Shipping Dressed... 246
Mennonites... 248
Milk Cellars, Under-ground... 247
Mushrooms, Fine... 248
Patterns of Husbandry... 246
Peaches, Delaware... 246
Pickles... 248
Poultry for Eggs... 247
Rape and Vetches, Tares... 247
Reports, Valuable... 246
Roat-house, How to make... 248
Sul-Soda for Manure... 247
Sand for Cranberry Marsh... 247
Scraps, Chandler's... 247
Sheep Nets... 247
Sow-Bugs—Wood-Lice... 247
"Split Hoofs"... 247
Steam on the Canals... 246
Summer-fallowing Prairie... 248
Thorough Pin... 247
Tobacco Leaf... 246
Twins... 248
"What is 'Pi'"... 248
Wheat, Clean Seed... 248
White Leghorn Pullets... 247
Wine, Rhubarb & Tomato... 248

Milking Machines.—"J. E. S.," Richmond Co., N. C. There are various machines invented for drawing milk from the cow, but none are in use practically that we know or have heard of. There are two principles involved in these machines, one to open the duct by inserting a tube and allowing the milk to flow out by its own weight, and the other to draw the milk from the teat by a pump, or by creating a vacuum into which the milk flows. We see so many practical objections to the use of these machines, that we can hardly advise any one to waste time in trying them.

Calendar for July.

Table with columns for Day of Month, Day of Week, and sunrise/sunset times for Boston, N. York, Philadelphia, N. Jersey, Penn., Ohio, Indiana, and Washington, Maryland, Kentucky, Missouri, and California.

PHASES OF THE MOON.

Table showing moon phases (3d Quart., New M'n, 1st Quart., Full M'n) and times for Boston, N. York, Wash'n., Chas'ton, and Chicago.

AMERICAN AGRICULTURIST.

NEW YORK, JULY, 1874.

July is a hot and busy month. We are in the midst of haying and harvesting, with corn, potatoes, beans, and roots to cultivate, hoe, and keep free from weeds. We have to think also of the next wheat crop, and not neglect our summer fallows. There are the cows, the sheep, the horses, the swine, and the poultry to be looked after. There is, perhaps, fruit to be picked and marketed. Altogether, the farmer has his hands full. He needs an active brain in an active body. If he has good health, the work should not discourage him. He will pull through. He should not get excited; he should not worry. He should keep cool; and the best way to do this, in more senses than one, is to keep steadily at work. Work will clear the mind and cool the body. But it should be energetic, spirited work, not slow, plodding drudgery. Every stroke should be directed by the mind and be given with a will. It is such work that tells. Few of us realize how much the character of farm work has changed. It is better to run a mowing machine than to swing a scythe all day, but there are men who are not happy unless they are engaged in some hard, steady work. They have not patience enough to manage a machine. They are mental sluggards. They want a machine to put itself together, to tighten its own bolts, to be self-sharpening and self-oiling. Such men are born hewers of wood and drawers of water. They will not make successful modern farmers. The farmer who has his mower, tedder, unloading-fork, self-raking, and self-binding reaper; who cuts feed, turns the grindstone, and pumps water by wind or horse power; who plants his corn with a drill, hoes it with a harrow, cultivates within an inch of the rows, cuts up the crop, and husks it with a machine, is a very different man from Hodge, the farmer, as he exists in the mind of the novelist or poet. We believe in farmers and in farming. There is not as much isolation on a good farm as in a large city. There is no lack of excitement or of mental stimulus. We have not time to be dull. The seasons are too short and the work too pressing. We are in a hurry to harvest our crop, that we may sow the next. We live in the future; and if we aim to improve our farms and our stock, we

can yearly see sufficient evidences of real progress to feed our hopes and encourage us to continue our labors. Farming is slow work, but we are building on a solid foundation, and are reasonably certain of our reward. Let us brace our minds with hope, and continue the good work. The prospects for good farmers in this country were never more encouraging than at the present time.

Hints about Work.

The Most Important Work on a farm is not plowing and sowing, haying or harvesting. These are big jobs that force themselves on our attention. They are rarely neglected.

Little Things, which we are apt to overlook and neglect, are the most important. We need to look more to the little rivets that fasten the sections on the cutter-bar of a reaper than to the main driving-wheel. Dipping lambs to kill ticks is more important than shearing the sheep, because more likely to be postponed and forgotten.

Farmers often Work too Hard.—Some of the most successful farmers we have ever known were men who kept others at work, but did little so-called work themselves. They knew how everything should be done, and saw that it was done promptly and well. They lent a hand when it was necessary, but took hold of no steady work that an ordinary laborer could perform.

Your own Health and that of your Family should be the first consideration. See that the cellar is clean, and the sink and out-houses are not giving off poisonous gases.

Dry Earth is a cheap disinfectant. Use it freely, and be not sparing of water, soap, and lime.

Personal Cleanliness would be less rare among hard-working men and boys if bathing conveniences were more common. A good swim is a good thing, but a man can be clean without having a river to bathe in. A tub of soft water, in the barn, if need be, with soap and sponge and towels, should not be lacking on any farm. We should think little of the man or boy who will not use them.

In Malarious Regions do not get up too early in a morning; and in our changeable climate no house should be without the means of making a fire at a moment's notice. If the evenings are damp or chilly, make a fire, if necessary for comfort, and keep the doors and windows open. Many people seem to think if they make a fire they must shut the doors.

Nutritious Food and plenty of it is essential to good health. A man who does not eat can not work. Meat soup is better than beer, and a cup of good coffee is more invigorating than a pitcher of hard cider. For a hard-working man, good bread and firm, fat pork, are better than cakes or cookies.

Work Lively.—It is less fatiguing to milk ten cows in an hour, than in an hour and a half, and you have the half hour to give them a little extra food, which is certainly good for the cows. Horses should rest in the pasture or the stable, and not when in harness. Heavy boots and slow motions belong to a species of farming which is fast becoming extinct. Do not carry one pail of water when you can carry two. Study the economy of labor. Do not waste your time or your energy. Make every stroke count, and let the strokes be given with a will.

Haying should be pushed forward rapidly. In our experience, it is not wise to wait for the weather. While the grass is green, a little rain or dew does not hurt it. We like to cut in the afternoon and evening, and let it lie all night. The next morning, when the dew is off, turn it or ted it with a machine. In the afternoon rake into windrows, and if timothy, draw it in; or if clover, put it in a cock and draw in as soon as ready—say the next afternoon, turning or opening the cocks in the meantime, if necessary. Clover makes capital hay if cut early and well-cured.

Wheat should be cut as soon as there is no milk in the kernels. If the field is square, and there are five men to bind, each man will have a side, and

they can go round and round the field after the reaper. A man will bind one side while the reaper cuts five sides. If the field is large and the crop heavy, a good reaper will give the five men all they want to do. See that the sheaves are of the proper size and well bound, and be careful that they are firmly stuck up in shocks that will shed rain.

If you Thrash as drawn from the field, the grain must be thoroughly dry and hard, and even then there is danger of the wheat heating if placed in a large heap. We nearly always thrash our own wheat as drawn from the field, but we are careful to turn the grain every two or three days, and spread it out as much as possible on the barn-floor.

Rake the stubble between the shocks immediately after the wheat is cut. If this is done in the evening, or in the morning while the dew is on, there will be less grain lost by shelling.

The Rakings, when you thrash from the field, should be loaded the night before and drawn to the machine. A good man, with nothing but sheaves to pitch, will send home the wheat as fast as a ten-horse power machine can thrash it. You require three wagons—one at the machine, one going back and forth, and one in the field.

Six-rowed Barley will be ripe about the same time as wheat, and you can cut it while the wheat is curing in the field; thrash both crops at one operation, and put the straw of both into one stack.

Two-rowed Barley is rarely ripe for some days after the wheat, and many prefer it on this account.

Tinding Barley into sheaves like wheat is the better plan, provided the crop is a heavy one.

Oats will not be ready to cut for ten days or two weeks after wheat, giving as a breathing spell. So far as the quality of the grain is concerned, oats are quite frequently injured by cutting too early. But where the straw is used for fodder, what we lose in the grain we gain in the straw.

Oats and Peas grown together, we cut with a Johnston reaper. The machine throws the crop off the platform into moderate sized heaps. These are turned once or twice, and then drawn to the barn and thrashed. If the weather is unsettled and the crop very green, it may be necessary to put it into cocks. If well cured, the straw is very nutritious, and is greedily eaten by sheep and horses.

Peas are sometimes pulled up with a rake. It is a slovenly practice. It injures the fodder and leaves a large percentage of the peas on the ground. True, these can be eaten by pigs and sheep. But at this season we have all the other stubbles for the stock to glean. It is better to "roll" the crop with a scythe, unless it can be cut with a reaper.

Cultivating Corn must, on no account, be neglected. The cultivators, with short whiffletrees attached, should be in the field and ready for use at a moment's notice. Then if a shower stops work in the hay or harvest field, or while the dew is on in the morning, start the cultivators, if it is only for an hour or two. The ground should never be allowed to crust over, and no weeds should be suffered to grow. We plant no pumpkins with our own corn, and cultivate frequently as late as the first week in August. "It is the last blow that kills the cat," and it is the last hoeing and cultivating that kills the weeds and leaves a clean corn stubble. Cultivate shallow—just deep enough to kill the weeds. If any thistles escape, cut them with a hoe.

Root Crops, such as beets, mangels, and rutabagas, must be kept thoroughly cultivated and hoed. Thin out the plants in the rows to twelve or fifteen inches apart.

Common Turnips, such as the Yellow Aberdeen, may be sown any time this month, and such varieties as the Strap-leaf may be sown as late as the first of August. Superphosphate of lime is the best of all manures for common turnips. It is far better to sow in rows wide enough apart to admit of the horse-hoe—say twenty-eight inches—than to sow broadcast.

Summer-fallows for Wheat must be repeatedly

stirred with the harrow and cultivator, and kept mellow and free from weeds.

Barley, Oat, or Pea Stubble, intended for wheat, should be harrowed or cultivated immediately after harvest, to start any seeds lying on or near the surface. Then plow carefully and well. Harrow and roll. Any weeds that start must be killed by the cultivator. Whether it is or is not best to plow again before sowing, depends on the character of the land and on the weather. On light land and in dry weather, we think it is not desirable to plow the second time. We want to retain as much moisture as possible in the soil, and one or two inches of loose, mellow surface soil, makes a capital mulch, and keeps the soil below moist and in good condition to start the wheat when the seed is deposited in it with a drill.

Weeds on Stubbles and in Pastures may be cut with a mowing machine, and if the seeds are ripe enough to grow, rake up the weeds with a wire horse-rake and burn them.

If you are Short of Grass, keep the horses in the stable or yard, and feed cut hay, shorts, and corn-meal. A large horse at hard work requires about sixteen pounds of hay and fifteen pounds of corn-meal per day. A bushel of cut hay weighs about eight pounds, and corn-meal about forty-five pounds per bushel. If you mix half a peck of corn-meal with a bushel of moistened cut hay, and a quart of shorts, you can let the horses have all of this mixture they will eat up clean three times a day. Let them have a little long hay in addition.

If Pasture is Abundant, turn the horses out at night. If they are at hard work, let them have all of the above mixture of hay and meal they will eat. They will probably eat but little, but they should have all they will eat. Make short nooning, and quit the earlier at night, so as to give the horses longer time in the pasture.

"Corn-Meal Soup" is an established institution on our own farm. We keep a half-barrel constantly full of water, with a little corn-meal soaking in it. The horses are allowed to drink all they wish. We let them drink the first thing in the morning, and again when taken to work. When brought home at noon, they are also allowed to drink before being put in the stalls, and again when taken out, and so at night. By standing a few hours, the chill is taken off the water, and allowing them to drink when brought in from work, does not seem to hurt them. If the meal gets sour, remove it and feed to the pigs.

Milk Cows must have access to pure water. If the pastures are poor, a feed of corn-fodder, cut a few hours before feeding, will be of great value, especially if the cows are fed enough meal to make the corn-fodder as nutritious as the best of grass.

Sheep should have their feet pared; and if there is any reason to apprehend foot-rot, dress their feet with any substance that will kill the virus. We use crude carbolic acid, mixed with an equal quantity of melted tallow, and put it on with a small brush, being careful to cover every part of the hoof, especially between the claws.

Dip the Lambs, to kill ticks, in a solution of carbolic soap or tobacco water. Repeat in two weeks. Towards the end of the month, dip the sheep also.

Swine should have access to water. With this, and a good pasture, breeding stock needs nothing more. Young pigs and store hogs, that are to be fattened this fall, should be fed liberally.

Salt seems necessary to the health of all farm animals. They will not eat too much, if they have access to it at all times. If they are allowed to go without salt for two or three weeks, they will then eat more than is good for them. For swine, we mix about two quarts of coal or wood ashes, one pint of salt, and half a pint of sulphur, and let the pigs eat all they will of it.

Work in the Horticultural Departments.

July should have been called the Month of Weeds. The larger share of the cultivator's ener-

gy, in whatever department, is expended in keeping down the plants that are not wanted. Those who claim that weeds are a great blessing, as they induce a frequent stirring of the soil, can now enjoy this blessing in the fullest abundance. Weeds, like fire, are easily controlled, if attacked while small, but when they get fairly established, it is often cheaper to plow up the crop, than to undertake to weed it.

Orchard and Nursery.

Where crops are planted between the trees, the surface should be kept clear of weeds, and the soil mellow and loose.

Pruning may be done this month. Aim to get a broad, open head, so that plenty of light and air can reach the fruit, to perfect it properly.

Budding may be performed as soon as the buds are well matured, and the bark of the stock loose enough to be raised easily.

Young Trees, in nursery rows, must be looked after. Keep clear of weeds. Be careful, in cultivating between the rows, not to injure the trees with the whiffletree. Use a short whiffletree, with the ends well covered with leather or woolen.

Seedlings ought to be shaded, and if very dry, water occasionally. Hand-weed when needed.

Grafts, set in the spring, will require looking after, as it often happens that the stock will throw out vigorous shoots, which will rob the graft of its nourishment. All such should be rubbed off as soon as they appear.

Thinning, if not already attended to, should not be longer delayed. The difference in the size and quality of the fruit, will pay for all the trouble, in the increased price.

Seeds.—Save seeds of forest trees and shrubs, as fast as ripe. Most kinds need to be preserved in sand, to prevent them from becoming too dry.

Fruit Garden.

There will be plenty of work in looking after the harvesting of the fruit, and destroying the weeds, which now grow rapidly.

Strawberries, in most localities, will be through with by this time. The mulch should be taken off, and a dressing of manure applied. If plants are needed for new beds, allow the runners to take root. The plants thus formed, may be set out in the coming fall, or the following spring.

Raspberries follow close upon strawberries, and will require picking daily. After the crop is gathered, cut out the old fruiting canes, and allow only three or four new canes to each stool; these should be tied to stakes, or trellises, so that they will not be broken by high winds.

Blackberries will often need to be tied up, owing to the large quantity of fruit they set. A heavy mulch will enable one to keep down the weeds, as it is often difficult to hoe among them. The young and vigorous canes for next year's fruiting must be tied up.

Grape-Vines.—Tie up the young shoots, and thin out the fruit on young vines. Pinch the laterals to one leaf, and as they again start, repeat the pinching. Keep a sharp look-out for beetles and caterpillars, which should be hand-picked. As soon as mildew appears, apply sulphur with a bellows.

Currants.—If the "worm" eats the leaves, dust with powdered white hellebore. When trained in tree form, the branches are liable to break down, unless supported.

Dwarf Trees need care in thinning the fruit. Preserve the proper shape of the tree, by removing all superfluous and pinching rampant branches.

Kitchen Garden.

Asparagus.—Do not cut too late. As soon as peas come to take its place, stop cutting, and give a good dressing of manure. Allow the tops to grow until fall, then cut and burn, to destroy the seeds, if they are not wanted for sowing.

Beans.—Plant a few rows for late snaps. Pinch Limas when they reach the top of the poles.

Beets.—Early varieties, sown this month, will grow rapidly, and make excellent roots for winter use. Use the thinnings for greens.

Cabbages and Cauliflowers for the late crops may now be transplanted from the seed-bed. Keep well hoed, and occasionally water with liquid manure, if convenient.

Celery.—Set for main crop in rows, three feet apart, and the plants six inches.

Carrots.—Hoe often, until the tops cover the ground so much as to prevent working.

Corn.—Plant the early sorts now, for late use, and for drying, if wanted. Keep the cultivator and hoe in motion among that already planted.

Egg-Plant.—See that these have plenty of manure, both liquid and solid. Do not allow the fruit to remain long in contact with the ground.

Herbs.—Transplant from the seed-bed, and keep well hoed.

Melons.—Pinch back the ends of the vines, so as to throw all the strength into the fruit already formed. Remove such fruit as will not ripen.

Onions will need hoeing frequently to keep down the weeds.

Peas.—It is of little use to plant peas at this season, as they are almost sure to mildew. If it is proposed to risk it, plant at least six inches deep.

Seeds.—As soon as they ripen, gather and store in a dry, airy place, where mice can not get at them. Save seeds of only the earliest and best-formed fruit, roots, etc.

Sweet-Potatoes.—Do not allow the vines to root; move them once a week, and keep free of weeds.

Squashes.—Hand-pick the squash-bug; this is the only effectual remedy. Allow the vines to strike root at the joints.

Tomatoes should be trained upon trellises of some kind, to keep the fruit from contact with the soil. Brush or hay is better than nothing, and should be used if nothing else is at hand.

Weeds are to be fought persistently, and, if possible, keep the horse and cultivator in motion among the larger crops; it will do no harm if done every day.

There will be much clearing up of odd corners, and of ground already cropped to be done, and advantage must be taken of this time of comparative leisure to attend to it.

Flower Garden and Lawn.

Lawns require frequent cutting to keep the grass looking fresh and velvety; this will also kill annual weeds. Perennial weeds must be taken out when young, with a spud.

Climbers.—Keep neatly disposed upon the trellises, and provide supports for all such as need them.

Lilies.—Tie to stakes as soon as they become tall enough to need it.

Gladioluses will need stakes to prevent their flower-stalks being broken. Most seedsmen and florists now keep neatly turned sticks, which answer very well for this.

Annuals.—Quick growing sorts may be sown now for late flowering.

Perennials.—Keep the ground carefully weeded. Sow seeds as fast as they ripen; most kinds will make plants strong enough to winter safely, and bloom next year. Some will remain dormant until spring.

Dahlias require some support for their flower-stalks. Remove all imperfect flower-buds as soon as they appear.

Sub-Tropical Plants, where grouped upon the lawn, need considerable care to keep them in a flourishing condition. Remove defaced leaves, and stake such as require it.

Foliage Plants.—Where beds of Coleus, and other so-called "foliage" plants are used, they should be cut back, so as to form compact, bushy plants.

Greenhouse and Window Plants.

It will be difficult to keep the plants in the greenhouse and windows looking well at this season, unless considerable care is used. Plants should not be subjected to hot, drying winds, as these will soon destroy them. Shading of some kind is needed during the summer months, otherwise the leaves will become scorched. Admit plenty of air through the ventilators every day, and during warm nights they need not be closed.

Commercial Matters—Market Prices.

Gold has been up to 113 3/4 and down to 110 1/2—closing June 12th at 111 as against 112 1/2 on May 12th. Receipts of Produce have been quite liberal since our last, and prices of Breadstuffs have been generally quoted lower, leading to an active business, in good part for export; the decline in ocean freights helping the outward movement. Corn has been exceptionally scarce toward the close, and prime samples having been greatly needed for prompt shipment, values have been quoted stronger. Provisions have been fairly active, but at irregular quotations, closing generally in favor of buyers. Wool has been in fair demand, and held with more firmness, on very moderate offerings of desirable grade. New Clip, especially California, is in better supply, but held above the views of purchasers, in most instances, checking operations. Manufacturers are the chief buyers. Tobacco is quiet, at rather easier figures. Hops, Seeds, and Hay are selling slowly, closing barely steady. Cotton is in brisk demand, mainly for forward delivery, on speculative account, at variable prices, closing somewhat more firmly. In most other lines, trade is slow.

CURRENT WHOLESALE PRICES.

Table with columns for various commodities (Wheat, Corn, Rye, Barley, Oats, Flour, etc.) and their prices for May 12 and June 12. Includes sub-sections for Gold, Flour, Wheat, Corn, Rye, Barley, Oats, and various oils and beans.

The following condensed, comprehensive tables, carefully prepared specially for the American Agriculturist, from our daily record during the year, show at a glance

the transactions for the month ending June 13th, 1874, and for the corresponding month last year:

Table showing transactions at the New York Markets for Receipts and Sales of Flour, Wheat, Corn, Rye, Barley, and Oats for 1874 and 1873.

Stock of grain in store at New York.

Table showing the stock of grain in store at New York for Wheat, Corn, Rye, Barley, Oats, and Mall, with bush and barrel measurements.

Exports from New York, Jan. 1 to June 11:

Table showing exports from New York for Flour, Wheat, Corn, Rye, Barley, Oats, and Peas, with bush and barrel measurements.

Receipts at head of tide-water at Albany each season to June 30th.

Table showing receipts at head of tide-water at Albany for Flour, Wheat, Corn, Rye, Barley, Oats, and Peas, with bush and barrel measurements.

New York Live-Stock Markets.

RECEIPTS.

Table showing week ending receipts for Beef Cattle, Sheep, Swine, and other livestock.

Average per Week. Beef Cattle, Sheep, Swine. Do. do. last Month. Do. do. prev's Month.

Beef Cattle.—The unprofitable business at the close of last month left dealers heavy losers.

The natural consequence was the diversion of 70 car-loads of stock to other markets, and a falling off of 2,000 head in the receipts during the first week of the present month, as reported above. This gave a firm tone to the market, and a recovery of all that had been lost the previous week. The improved tone gained strength the next week, and the extra quality of the offerings helped the market to make another advance of 1/2c. This improved feeling has marked the whole of the month's business, and a steady market throughout, with a constantly advancing value of the better grades, and a fairly active demand for inferior grades has been the result. At the close of our report the feeling is somewhat easier, and inferior Texans are decidedly weak, although the market was cleared early in the day of all supplies. Texans sold at 8 1/2 @ 12c. # D., to dress 56 to 57 lbs. per cwt.; common to prime native steers brought 11 1/2c. @ 12 1/2c., and selections to dress 58 to 59 lbs. # gross cwt. realized easily 12 1/2c. @ 13c. # D.

The prices for the past five weeks were as follows:

Table showing week ending prices for Beef Cattle, Sheep, and Swine.

Milk Cows.—Dealers have met a brisk demand for good cows, and comparatively scant supply has kept the price for extra up to \$90 per head, calf included.

Common fair to good cows are selling at \$50 to \$75 each. Calves.—The market for veals has been irregular, and closes with a downward tendency. Buyers are holding off, and business is dull, at 4 1/2c. @ 6 1/2c. # D. for common to good State veals. Veals averaging 135 lbs. sold at 6c. # D. Sheep and Lambs.—The business in sheep is reported as having been a losing one, and early in the past month sheep sold at a loss of \$100 per car-load to the owners. Slaughterers also complain of an unprofitable trade, and the market closes without any recovery. Sheared sheep are dull, at 5 1/2c. @ 7c. # D. Lambs are also weak and declining, the last sales at 8c. @ 11c. # D. Swine.—The market for live hogs has been without business, all arrivals being consigned direct to the slaughterers. Dressed hogs have been easy throughout the month, with a gradual decline from extreme rates of last month to 7c. @ 7 1/2c. # D. The bulk of the business at the close was done at 7 1/2c. # D., with a tendency toward lower prices.

**SPECIAL PREMIUMS
STILL OFFERED.**

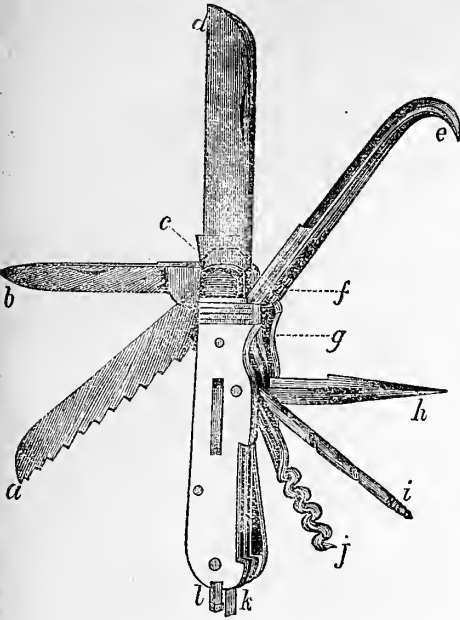

MULNUM IN PARVO KNIFE, OPEN—WEIGHT 2 OZ.

The General Premium List closed July 1st. The following Special Premiums are continued until further notice:

The Multum in Parvo Knife for 8 subscribers to *American Agriculturist* at \$1.50 each a year. (Knife sent post-paid.)

The Beckwith Improved \$12 Sewing-Machine for 10 subscribers to *American Agriculturist* at \$1.50 each a year.

The Beckwith Portable Family Sewing-Machine, price \$20, for 30 subscribers to *American Agriculturist* at \$1.50 each a year.

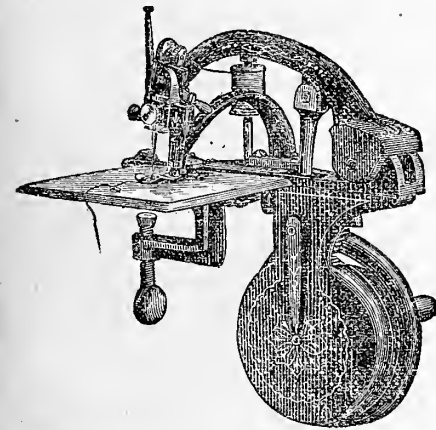

BECKWITH PORTABLE \$20 SEWING-MACHINE.

To secure the Chromo, mounted and prepaid, 25 cents must be remitted with each subscription for *American Agriculturist*.

N. B.—Two half-year subscribers in all the above cases may count for one full year in a Premium Club List.

Concerning the Advertisements,

We have a few words to say to our READERS: We mean to exclude everything which we think may be injurious or useless to the readers of this journal. We shut out all advertisements of patent and secret medicines, because we don't believe people ought to buy or use them. It is a pretty severe sacrifice to do this, because the medicine makers get from sick and nervous people dollars for what costs them half-dimes, and they can, and do, pay publishers largely for space in which to work upon the fears and hopes of the people. We also

ask advertisers of good things, when they are not known to the editors personally, or by good repute, to furnish satisfactory evidence that they have both the *ability* and the *intention* to do what they promise to do in their advertisements, and if we are not well enough satisfied on this point, they are excluded. Our strict rules annually shut out a hundred thousand dollars of advertising, which is admitted into most newspapers. Sometimes, with all the care we can exercise, an objectionable advertisement gets in, but on our attention being called to it, we stop it. There have been one or two books, for example, admitted, which, though proper enough to be read by parents or adults of good judgment, we do not wish to bring to the notice of children or young people of prurient imagination. We shall try not to err even in this respect again. And now, after this explanation, we ask our readers to always look over and through the advertising pages. They will get many suggestive hints about business, by so doing. And further, as our advertisers are generally a good and reliable class of persons, and are in a good place, among good company, we like to have them know that they reach, through this journal, a good class of readers—we think the best class in the world. So when our readers send inquiries, or orders, or for circulars, to our advertisers, they will confer a favor upon them and upon us by mentioning the fact that the advertisement was seen in the *American Agriculturist*. (We may hint, privately, that this may be useful to the readers, for our advertisers generally know that if there is a "black sheep" among them who does not deal honestly by our readers, he will thereafter be liable to exclusion from these columns, if he does not also "catch it" by an editorial notice, that will not be of the most pleasing character.)

Please tell your Friends

THAT THEY CAN SECURE THE
AMERICAN AGRICULTURIST

Six Months for only 75 Cts.

In order to enable many persons to become acquainted with this valuable Journal, who have not hitherto taken it, the Publishers will receive subscriptions for it for the months commencing with July and ending with December, 1874, at seventy-five cents each. Will not each of our present subscribers speak "a good word" to friend or neighbor?—Please note: We will send the *American Agriculturist* for six months, beginning with July, 1874, for seventy-five cents. This offer, of course, does not include the beautiful chromo "Up for Repairs," which is offered to all *yearly* subscribers free, when taken at 245 Broadway, or twenty-five cents extra when sent prepaid. Give the paper a six month's trial trip, or better still, try it a year.

... P. S. ...

Better Still!
BEAUTIFUL \$5 CHROMO,
AND
Half a Year's Subscription,
ALL
For a Single Dollar.

Considering the hardness of the times, and in order to meet the wishes of a great number who desire to have our beautiful chromo, "UP FOR REPAIRS," but who did not feel able to pay the \$1.75 required to get it, the Publishers have just decided to send the *American Agriculturist*, from July 1st to the end of the year, and to deliver, free of postage, a mounted copy of this beautiful **Chromo**, which has given so much pleasure, all for \$1, if promptly called for.

Please make this known to all your friends and neighbors.



containing a great variety of items, including many good hints and suggestions which we throw into smaller type and condensed form, for want of space elsewhere.

Remitting Money: — Checks on New York City Banks or Bankers are best for large sums; make payable to the order of **Orange Judd Company. Post-Office Money Orders** for \$50 or less, are cheap and safe also. When these are not obtainable, register letters, affixing stamps for postage and registry; put in the money and seal the letter in the presence of the postmaster, and take his receipt for it. Money sent in the above three methods is safe against loss.

Postage: On American Agriculturist, 12 cents a year in advance. Double rates if not paid in advance at the office where the papers are received. For subscribers in British America, the postage, as above, must be sent to this office, with the subscription, for prepayment here. Also 12 cents for delivery of *American Agriculturist* in New York City.

Bound Copies of Volume Thirty-two are now ready. Price, \$2, at our office; or \$2.50 each, if sent by mail. Any of the last seventeen volumes (16 to 32) will also be forwarded at same price. Sets of numbers sent to our office will be neatly bound in our regular style, at 75 cents per vol. (50 cents extra, if returned by mail.) Missing numbers supplied at 12 cents each.

Our Western Office.—Our friends in the West are reminded that we have an office at Lakeside Building, Chicago, Ill., in charge of Mr. W. H. Busbey. Subscriptions to *American Agriculturist* are taken there, and sample copies of the paper and chromo are delivered, and orders received for advertising on the same terms as in New York. All our books are on sale at the Western Office. Please call and examine, buy, subscribe, and advertise.

Sale of Hearth and Home.—During four years past, the Publishers of this Journal have also issued the weekly HEARTH AND HOME. Mr. Judd has been absent in Europe for a year, and experienced so great benefit in the improvement of his health, that he desires to be more at liberty in the future to devote himself to the *American Agriculturist*. The Publishers have therefore deemed it expedient to be relieved of the care and labor of a weekly journal, and HEARTH AND HOME has been sold to the Publishers of the Graphic Company, of 39 and 41 Park Place, who will hereafter issue it with illustrations by the new photographic process. And now, with the well-known and well-tried corps of Editors at their posts, and with the attention of all concentrated upon this Journal, the Publishers are confident that their old favorite, the *American Agriculturist*, will be more than ever worthy a place in every home.

Other Basket Items on page 273.

SUNDRY HUMBUGS.—It seems necessary to remind our friends, from time to time, that this column is not the place in which individual grievances can be set forth. We take quite as much care to avoid doing injustice to innocent parties, as to do justice to those fraudulent persons, who deserve the distinction of a place among humbugs. Men, on the average, are suspicious, and if mistakes occur in their dealings with persons at a distance, they at once conclude they have been defrauded. There is no business in which dissatisfaction is more likely to occur, than in that of seedsmen. Probably not one person in ten can sow seeds properly, yet all failures, from whatever cause, are set down to dishonesty on the part of the seedsmen. There is hardly one of our seedsmen, even those of the highest reputation, of whom we have not had complaints, accompanied with a request to put him among the humbugs. Upon investigating such cases, we have found that the fault was generally on the part of the complainant, and the dealer ready to make ample reparation, whenever the fault has been his own. In fact, no dealer in seeds, or other matters, in which a good reputation is all important, can afford to put it upon no higher ground—to be dishonest. A seedsman, florist, or nurseryman, who gets a reputation for inaccuracy or unfairness, might as well shut up shop. The same remark will apply to dealers in live-stock of all kinds, from bees to Shorthorns. That Pennsylvania live-stock concern, of whom we have had so many complaints, would have been shut up long

ago, had any of the swindled parties one particle of spunk. Each of the many persons who has come to us with complaints, appears to have a good case, but instead of bringing the rascals into court, they write to us, and ask us to expose the concern, and not give their names. We are not in the catspaw business; and while, when convinced that systematic fraud is being practised, we are willing to take the risk of exposing it, we can not take up cases for which there is a ready remedy. The clergyman in Missouri, who thinks he has been defrauded in a hee transaction, a correspondent in New York, whose ducks' eggs did not hatch, and the one in Massachusetts, who is in trouble about his pigs, will see that we can not show up certain dealers as humbugs, upon their simple accusation, and without having available witnesses and facts to justify us before a jury, if need be.

HORTICULTURAL HUMBUGS

have been so frequently exposed in our columns, that we supposed no reader of the *Agriculturist* could be taken in by those French scoundrels, who appear each spring in our principal cities, sometimes as Lafayette & Co., and in other years under other names. These chaps have catalogues so similar, and pictures of their wonderful products so alike, that they are probably all parts of one great swindling concern. "Greenhorn" sends us one of these French-English catalogues, with the things marked which he has purchased, and asks if he has been "sold." Now, friend "Greenhorn," you have marked on this catalogue, "Mezel Cherry, cleveu in one pound;" Pear, "Moastrous of Africa, heavy, four pounds;" "Prince's Plum, without stone," and other equally absurd things. If you do not know that "Tree Strawberries," with fruit weighing a pound; that apricots, weighing a pound each; that raspberries, with "large fruit as a egg of a fowl," are barefaced frauds, you have taken a very sure, but very expensive way of learning. Know, O "Greenhorn," that our nurserymen are as wide-awake as any other dealers; and if there were upon the face of the earth, any such trees or plants as are given in the catalogue you sent us, they would have them, if they had to send to the most remote countries. New York City is a great field for these impostors. Gentlemen who have country places, and who would, by no means, pay a skilled gardener bricklayer's wages, will spend their money freely upon these novelties, because they are "French," and their claims are set forth with blushing impudence and lying. We confess to feeling very little compassion for those who throw their money away in this manner. . . . A New Yorker, who does not give his name, offers "Two of the greatest medicinal and sweet-scented plants in the world," "presented for the first time to the American public." One is *Nigella sativa*, (intended for *sativa*), "makes one of the greatest tonic medicines in the world." If the friend who sent us the circular, knows of any old grandmother's garden, where the plants of fifty years ago are yet undisturbed, he will find this wonderful *Nigella*, grown under the name of "Nutmeg flower." Its only novelty consists in its antiquity; its seeds are aromatic, and were formerly used as a spice. The other plant is *Phyllanthium aquaticum*, which should be spelled *Thellandrium*, and is now known as *Eranthis*. This, it is said, "is used for bronchitis, consumption, and obstinate ulcers." Now, we advise all afflicted with either of these troubles, not to dose themselves at all, but especially not with this "*Phyllanthium*," as it is a dangerous narcotic poison, and like related plants needs to be used with great caution. While we have no reason to doubt that the advertiser will furnish the plants upon the terms he proposes, they are offered under incorrect, and no doubt, mistaken ideas of their value; and so far as this goes, they are horticultural humbugs.

THE NON-EXPLOSIVE POWDER MAN

has been in Troy, and one Trojan speaks his mind on the subject. If any ladies take offence at what is said, they must remember that the remarks are not ours, but those of our irate correspondent. He, in substance, says: "I take your paper, and am pretty well posted as to the leeches of humbugs, but my wife, confiding as women generally are, has been duped by one of them. An 'Agent' called at my house, with some powder to render kerosene oil non-explosive, and nothing would do but he must try some of it, to convince my wife of its qualities. He put some of it into a Perkins & House's safety lamp, and it has succeeded splendidly! It rendered both the oil and the lamp non-explosive, as it stopped up the tube which supplies oil to the wick, and of course rendered the lamp perfectly useless. I am not in the habit of using strong language, but if ever that agent comes within range of a 'Springfield' that I brought home from the war, I will try some powder that will not be 'non-explosive.'" Our advice to the Trojan friend is, to say nothing, buy a new lamp, and set the other aside, as a sort of beacon, to point out shoals and dangerous places. The wife has had her les-

son, and has not paid half so dearly for it, as she would had she bought some quack medicine. It might be worse.

CHEAP AND WORTHLESS SEWING-MACHINES

are still complained of by those who are victimized by the vendors. Some complain, that they saw advertisements of these things in a horticultural paper; such would do well to present their grievances to the paper, through whose agency they were induced to invest. We can not help those who have sent money, and receive nothing in return. It would require the whole time of one man to investigate all the various complaints, and amount to nothing. The best way is, to regard the amount lost, as so much paid for instruction, and if it teaches caution in future, it may not be a bad investment. . . . Cheap Carpets. "J. L. H.," Kansas. We know nothing of the concern you inquire about, but if you succeed in getting good carpets at 37½ cents a yard, we hope you will let us know, as we would like some too.

A GRAND "PRIZE CONCERT;"

this time it is in Texas, and it does not pretend to be for any State library, children's home, or use any other charitable cloak to cover its sin. It is a prize concert for the benefit of the manager, and so far is above-board, but the circular accompanying the tickets, which are sent out freely to people in the Western States, says: "Should your State laws prohibit the sale of 'Prize Concert tickets,' (remember that they are concert tickets, and not lottery tickets,) you can then advertise for applications for tickets." If any one thinks he can get around the law by following this advice, he would soon discover his mistake in any law-abiding community. . . . That Kentucky Library lottery advertises one more final distribution, but it will no doubt keep at it so long as a dollar is to be made.

MEDICAL HUMBUGS.

There is one thing, that we have repeated again and again, and yet it does not seem possible to make it generally understood. It is, that it is perfectly useless to send to us for our opinion of any "doctors," who advertise cures, or advertise their medicines—no matter in what papers they advertise, or where they live, or how many distinguished names they may have appended to their "certificates." We hold them all to be unsafe, and to be avoided. Notwithstanding we have given this notice so many times, scarcely a day passes, but the mails bring us letters, asking about these advertising doctors. We have no acquaintance with any of these chaps, and we advise every one to let them alone; we make no exceptions whatever. Some are out-and-out swindlers, others are ignorant pretenders, without any knowledge of medicine whatever, and if, by chance, there is one among them, who has a right to the title of M. D., the very fact of his advertising his claims, and vaunting the cures he has performed, shows that he could not make himself a position in the medical profession, and has gone into quackery to make money. . . . Clark Johnson, M. D., Jersey City, turns up again, in the form of a letter to an agent in Texas, in which he says of the exposures in the "*Agriculturist*," "particularly do we ignore them since we know the cause to be jealousy of our unprecedented success."—This is pretty good for a man who does not exist. If there only was such a person, as Clark Johnson, M. D., what a fellow he would be! . . . A most pernicious little pamphlet bears the title of "Medical Good Sense," and claims to be published by the "Manhattan Medical Institute." This sets forth a delicate disease, which no one would care to have, in an alarming light, and then gives "an infallible test," by which those who had their fears excited by the description, may themselves tell, whether they have the disease or not. The test is, to put some urine in a pint-bottle, and set it in a cool place, and if at the end of three days and nights there is cloudiness or sediment, there is "unmistakable evidence" of a serious derangement, and, of course, the only safe thing to do, is to send some of the sediment to the author of this pamphlet for microscopic examination. Now, every one who knows anything about such matters, is aware, that cloudiness in the urine, after standing in a cool place, is a very likely thing to happen, and it is not an "infallible test" for anything. It is just a dodge of this humbug, to frighten people into coming to him for treatment. . . . There is a rascally Dr. " & Co.," in Dalton, Ga., who is using the U. S. mails for a nefarious purpose. The proper officers down that way should put a stopper on him or them. . . . The medical humbugs are not a cheerful lot generally, but once in a while a bit of drollery turns up among them. A friend sends us an advertisement from a daily paper, which reads:

"TO CAPITALISTS.—DURING THE MEXICAN WAR of 1846 I was attached to the Army of the United States, and while there in 1847, obtained a very valuable medical recipe for purifying the blood, etc., of an aged Aztec Indian woman. I have not the means to bring it before the public. There is a fortune in it."

If any capitalist wishes to make a "fortune" by "purifying the blood, etc., of an aged Aztec Indian woman," we will give him the advertiser's address.

B. K. Bliss & Sons' Removal.—This seed establishment is on the move to 34 Barelay st. Cause, want of sufficient room in the old locality for the rapidly increasing business.

The Patrons of Husbandry have at last met with the only thing needed for their complete success—persecution. However swimmingly they have gone on upon their own merits, having now been thoroughly maligned, and held up as something to be avoided, they will prosper with unprecedented vigor. An Anti-Secret Society held a meeting a few weeks ago at Syracuse, N. Y., at which a new political party was proposed, and at which Mr. Chas. W. Green "went for" the Patrons and the Granges in the most absurd style. For the good he has done their cause, the Patrons should pension Chas. W. for life. In our view of the matter the officers and members of the order make a mistake in replying to him. Let him go on and advertise them.

Delaware Peaches.—Last month we gave a very favorable report of the prospects of the peach crop, since then an unfavorable change has taken place, much of the young fruit having fallen. If we accept the statements of the local papers, the estimate of 2,500,000 baskets, has dwindled down to about 100,000.

Hibberd's Horticultural Works.—Messrs. Groombridge & Sons, London, send copies of "The Amateurs' Flower Garden," "The Amateurs' Greenhouse and Conservatory," "The Fern Garden," "The Amateurs' Rose Book" and "Field Flowers," all by Shirley Hibberd, a horticultural author who is well known for his vigorous style and practical skill. These works are issued in a handsome form and finely illustrated, and are decidedly popular in England. They will be useful to such American amateurs as have sufficient horticultural knowledge to enable them to adapt their directions to the peculiarities of our climate. The same house publishes "The Floral World and Garden Guide," an illustrated monthly edited by Mr. Hibberd. The year's numbers of this make a fine volume.

Sale of Thorough Bred Horses.—The sale of horses from the studs of August Belmont, Esq., and Messrs. Hunter & Travis, took place at the Nursery, near Babylon, L. I., on June 11. There was a large attendance and the prices realized were fair on the whole. Several of the animals, however, were withdrawn for want of bids equal to their estimated value.

Valuable Reports.—Just as we go to press, there come to hand two reports too valuable to be disposed of in a hurried note: The Proceedings of the American Promological Society for 1873, and the Sixth Annual Report, by C. V. Riley, on the Noxious and Beneficial Insects of Missouri. These will receive attention another month.

Steam on the Canals.—The Baxter steam canal-boat has been awarded a premium of \$35,000 by the Legislature of New York, on condition that six of the boats be put into service forthwith. A company has been organized, with a capital of a million dollars, to build and run twenty of these boats this season. The reduction in the cost of transporting grain between Buffalo and New York, by these boats, is about three-fourths of the former rates. Now we need enlarged canals.

Shipping Dressed Meats.—The Texas and Atlantic Refrigerator Company have now one hundred cars engaged in transporting dressed beef from Texas to Eastern cities. One hundred beeves are slaughtered daily at Dennison, Texas, and the number will soon be increased to five hundred.

The English "Lock-out."—The "lock-out" of English farm laborers still continues. This is really a strike upon the part of the farmers, who are the employers of the laborers, the desired effect of which is to destroy the agricultural laborers' union. The need for laborers is pressing, and Belgian immigrants are being introduced, to take the place of the union laborers. The introduction of Chinese laborers into England has even been suggested. It is difficult to realize the altered condition of things in England, as evinced by these occurrences.

The Tobacco Leaf.—"J. W. H.," Hartford, Ct. The "Tobacco Leaf" is a weekly journal, devoted wholly to the tobacco interest, and will be found to contain a large amount of special information, of value to tobacco growers. It is published at 142 Fulton street, New York, for \$4 a year.

See Page 273 for other Basket Items.

"Songs of Grace and Glory," is the title of a new music and hymn-book for Sunday-schools, published by Horace Waters & Son, New York. Price 35 cents. We rarely see such good mechanical execution in so cheap a work, while the hymns and music are of a better class than are found in many of the music-books for Sunday-schools.

Farmers' Conventions.—The Farmers' Reform Convention of Indiana met at Indianapolis, and the State Farmers' Convention of Illinois was held at Springfield, both on the same date, June 10th. Both bodies set forth a "platform," and nominated a ticket for State officers. In neither State is the governor to be elected this year, and the contest will be over the other officers. As these are the first general elections in which a distinctly farmers' party has taken part, the results will be watched with interest by both the friends and the enemies of the movement. The platform or enunciation of principles in each State such as much commend itself to all who are not professional politicians. For ourselves, we rejoice at anything which awakens farmers to the fact that it is their duty to take a part in public affairs, and that it is a neglect of this duty which has allowed State matters to be mismanaged.

Holding On.—California farmers are now shipping their wheat direct to Liverpool, rather than sell at the current rate in San Francisco, which is about \$1.85 per 100 lbs. Some time ago, the same wheat could have been sold at \$2.35 per 100 lbs. An offer of 1,200 tons of choice wheat, to be delivered in July, at \$1.65 per 100 lbs., was recently made and refused.

Buckwheat for Cows.—"W. L. C.," Montgomery Co., Ohio. Our own experience with buckwheat for dairy cows is unfavorable, at least so far as regards the quality of the butter. It is true that it increases the flow of milk, but the butter yielded is white, and of poor, greasy flavor. As to the increased quantity, that has probably been shown as well, by some experiments made at the farm of the Eastern Pennsylvania Agricultural Society, in January last. In a week's feeding, when wheat bran was added to the feed, sixteen cows produced 1,252 lbs. of milk, yielding 117 lbs. of cream, and 57% lbs. of butter. The next week an equal quantity of buckwheat bran was substituted for the wheat bran, and the cows produced 1,262½ lbs. of milk, yielding 121 lbs. of cream and 59% lbs. of butter. During the last week the cold was much greater than the previous one, which would show a still greater value for the buckwheat. Nothing is said, however, as to the quality of the product.

Crop for Green Manure.—"A. W. H.," Clinton Co., Pa. It is too late now to sow any crop for green manures, except buckwheat. This may be sown up to the latter part of this month. We would sow at least a bushel of seed per acre.

Time to Market Hogs.—"M.," Warren Co., Iowa. The best time to market a hog is when he has made the largest growth upon the least feed. For early spring pigs this is generally in the next winter. At eight or nine months a good hog well kept from its birth, might weigh from 300 to 400 pounds, according to circumstances. If such a hog is kept over the winter, and well fed all the time for another year, its extra growth will hardly pay for the feed, and it will be too heavy for packers' use. In winter-time there is less growth for the same amount of feed than at any other season, therefore the objects should be to have the pigs come early, feed them well, and kill as soon as desirable in the early winter.

Poultry for Eggs.—H. B. Lasher, Ulster Co., N. Y., writes that he is now managing a henry for the production of eggs and fowls for market. He has 800 layers. We shall be glad to hear how our correspondent succeeds.

Corn Shelled or in the Ear.—"F.," Madora, Iowa. There is always more or less waste in feeding dry corn either in the ear or shelled. We have fed corn in the cob with the least waste, when it has been put into a barrel the day before it was to be fed, and scalded with boiling water, leaving it to soak until fed. This plan has been about as cheap as grinding the corn and feeding raw meal.

Sow-Bugs—Wood-Lice.—A gentleman from Westchester County, N. Y., came to us with specimens of a depredator, which makes serious trouble in his garden by attacking Asters, Amaranths, and other annuals, it being especially fond of Mignonette. The culprit proved to be what is, in this country, popularly known as "sow-bug." It is not an insect, but a crustacean, and more nearly related to the crab and lobster

than to a "bug" of any kind. It is a species of *Oniscus*, usually found under boards and stones, in damp places, and though we have heard of its being troublesome in greenhouses, we never knew it to be annoying in the open border. *Oniscus asellus*, the wood-louse of England, is a pest in greenhouses there, especially to orchids. The gardeners in that country rely mainly upon trapping: the animals have a desire to secrete themselves in crevices, and traps are made by stuffing flower-pots full of hay, placing two boards together with a small stick, to separate them, so as to leave a hiding-place, or by cutting a potato in half, scraping out a portion of the interior, and placing it cut-side down upon places they frequent. If any of our readers have had any experience with this crustacean, we hope they will give it for the general good.

Sal-Soda for Manure.—"J. M. A.," Huntingdon Co., Pa. Sal-soda, or crude carbonate of soda of the shops, is of no value as a fertilizer. Common salt, which is chloride of sodium (sodium in the metal, the oxide of which is soda), is a far better means of supplying soda to the soil, and is frequently of great value. We have greatly added to the yield of clover and wheat by the use of a bushel of salt per acre, but never knew or heard of any benefit accruing from the use of sal-soda.

Poland China Hogs.—"A. G. F.," Warren Co., Iowa. The Poland China, or Magic hogs, can hardly be called thoroughbred yet, but, notwithstanding this, they are an excellent race of hogs where large size is wanted, and probably as good as any for general use where corn is cheap and heavy pork is saleable. They can be procured of any of the breeders whose names are found in our advertising columns.

"Split Hoofs."—"A. G. F.," Warren Co., Iowa. Sand crack or "a split hoof" is very difficult of cure, without entire rest until new horn grows from the coronet or upper part of the hoof. But light work may be done if any blacksmith can be got who can put a bar-shoe upon the foot. When this shoe is put on, the crack should be cleaned of all dirt or sand, and the edges pared evenly. At the upper end of the crack a hot iron should be drawn across the horn in the shape of a Y, or a cut should be made with a sharp knife partly through the horn in that shape, so as to separate the entire horn from that which is cracked. The nail upon each side of the crack at the bottom of the foot should not be clenched until some strong, fine wire is wound in figure 8 form around them. They should then be clenched so as to retain the wire in place. When a new shoe is put on, the same should be repeated, bar-shoe as well, until the crack grows out altogether.

Sheep Nets.—"W. Y.," Wytheville, W. Va. The nets used in hurdling sheep are made in England. We have not the facilities here for making them cheaply enough. Mr. William Adamson, Gainesville, Pr. William Co., Va., writes us that he has imported some for his own use, and will furnish them to those who want them.

Manure for Clay Soil.—"E. W. C.," After barn-yard manure, the best fertilizer for a clay soil is probably lime, with clover plowed under after it.

Butter from Sweet Cream.—"H. B. O.," Whitinsville, Mass. The butter referred to in the extract sent, and also at page 238 of "Flint's Dairy Farming," would not be marketable butter by any means, nor will it retain its flavor long. It is in fact a sort of sweet cream cheese, white, of delicate but not true butter flavor, and is not really butter. When we speak of butter, we refer to the article known and sold as butter in the markets and in daily use, and we know of no method of making this without some mechanical process of agitation as in churning.

Thorough-Pin.—"J. B. D.," Union Co., Ohio. The weak points in the large, heavy Norman horses are the feet and legs. They are specially subject to thorough-pin and other like troubles, and if they are cured, the difficulty generally returns as soon as they go to work again. The proper treatment, however, is to let the horse rest, take off the shoes, and let the feet rest upon soft, level ground, if possible. Use no shoes with high heel-corks, which, throwing the leg out of line, strain the sinews and cause wind-galls, thorough-pin and spavins. Use a Goodenough shoe when the shoes are replaced, and bandage the part of the leg with a long narrow strip of cotton-cloth, and keep it wetted with cold water, with tincture of arnica added in the proportion of one ounce to each pint.

"Alfalfa," or Lucern.—"M. A. C.," North Topeka. It is in vain to try to raise lucern (or the so-called alfalfa), unless the ground is free from

weeds. Then it should be sown early in spring, in drills 9 inches apart, which might be cultivated with a walking sulky cultivator, by changing the teeth to snit the rows. In this way it would make a very rapid growth and soon cover the ground. It should be cultivated every spring in the same manner, if the ground is at all weedy.

Sowing Clover and Timothy.—"V. W. K.," Union Co., Ill. Clover and timothy may be sown in July. We once had an excellent stand, when they were sown with a crop of buckwheat on the 12th of July. On that occasion, 150 lbs. of Peruvian guano, sown with the seed, no doubt helped the grass and clover.

Feed for Early Spring.—"C. H.," Reno Co., Kan. The best feed for early spring is rye sown early in the fall. The ground may be prepared now or next month, and if low, it should be ridged in narrow lands, not over five paces wide. This will keep it dry during winter and spring. It may be pastured, and the ground afterwards plowed for corn.

Horn Ail.—"O. E. S.," Bath, Me. The disease known as horn ail, is not a disease of the horn at all, but a general constitutional disturbance, resulting from various causes, which shows itself by inflammation of and suppuration from the bronchial tubes, and the nasal lining and sinuses. It is very similar in effect to what is known as the epizootic in horses. It is probably better characterized as influenza, or catarrhal fever. There is much fever, dullness, and heaviness of the head, with heat around the base of the horns, and general distress and suffering. The best treatment is to give a purge, if the bowels are constipated, but if there is considerable looseness, an ounce of aromatic spirits of ammonia might be given, in a pint of water. The feet should be bathed copiously in hot water, and the body should be rubbed briskly with a coarse woolen cloth, and afterwards clothed with a blanket. If perspiration and discharge from the nostrils can be induced, a cure is begun. To effect this, a bag of scalded chaff should be hung around the muzzle, and wetted occasionally with hot water and vinegar. After the bowels are regulated, two ounces of sulphate of potash may be given night and morning, until the fever is removed. Good nursing, plenty of cold water, and soft bran mashes, will finally bring the animal round again. If the disease is neglected, pneumonia may follow it, and is generally fatal. It usually follows a hard winter and poor keep.

Soiling Crops.—"Subscriber," Kendallville, Ind. Without knowing the exact condition of the soil, it would be difficult to say what would be the best grasses for a permanent pasture. On a strong, clay loam, however, it would be safe to sow in August, or early in September, 6 quarts of timothy, 1½ bushels (21 lbs.) of orchard grass, and 1 bushel (14 lbs.) of Kentucky blue grass. The ground should be made very fine, and should be rolled after seeding, instead of being harrowed, which would cover the seed too deeply. In the spring, 6 quarts of red clover may be sown upon the last snow. These grasses may be sown with rye, which may be pastured in the fall, if sown early, and then be cut for fodder in the spring. The blue grass will not appear until the third year, when, if the soil and locality are congenial, it may in time occupy the ground. Tares or rape may be sown now for late fall cutting for fodder, or cabbage plants be set out; these can be purchased very cheaply by the thousand, or white, yellow or Cow-horn turnips may be sown, all of which will make valuable fodder crops.

White Leghorn Pullets.—Miss "M. A. C.," Chataqua Co., N. Y., writes, that her 12 white Leghorn pullets have laid, in 5 months and 10 days, since December last, 103 dozen of eggs.

Underground Milk Cellars.—"W. J. H.," Brady's Bend, Pa. In the *Agriculturist* of October, 1873, we gave descriptions, and engravings, of buildings suitable for milk cellars, to be built in a bank.

Double-Yolked Eggs.—"A. D.," Louisville, Ky. The large eggs which contain double yolks are rarely hatched. If properly fertilized and successfully hatched, they would doubtless produce twin chickens, or by reason of a mechanical annexation of the yolks or growing bodies, they could produce malformed or monstrous chicks. A recent case of this occurred in Illinois, and is reported in a trustworthy paper. A chicken was hatched which had but one head, one neck, one breast-bone, and then the chicken separated into two bodies with four legs and four wings. The curiously malformed bird, or birds, was accidentally killed, and was found to have one heart, liver, and gizzard, but the intestines split into two about one inch from the gizzard, and there were two sets of them, one for each body. This was probably produced from a double-yolked egg.

Yield of Corn in Nebraska.—The State Board of Agriculture, of Nebraska, offered a premium of \$50 for the best yield of corn in that State in 1873. The premium was awarded to M. M. Nelson, of Cass Co., whose crop was raised on thirty-five acres of ground, which was broken two years before. The statement sworn to by the grower was as follows:

Yield of corn upon the 35 acres.....	3,202½ bushels.
Average yield per acre.....	91½ "
Weight of corn, per bushel.....	63 pounds.
Total cost of the crop.....	\$166.25.
Cost per acre.....	4.75.
Cost of corn, per bushel.....	5½ ¹⁰ cts.

The variety grown was known by the local name of Mahogany. The cost is made up of the very reasonable, or we may say, very low charges of \$1.25 per acre for plowing, 45 cents for planting, \$1.80 for cultivating, and \$1.25 for harvesting. We suppose the ears were stripped from the stalks, which were not "cut up," as is the method in the Eastern States.

Some Dairy Items.—"Subscriber," Colorado Territory. The lactometer is not made expressly for testing milk; its purpose is simply to test the specific gravity of a liquid. Used alone, it is a very fallible instrument, and is calculated to mislead as much as to instruct. A cream gauge should be used along with it, and then, in the hands of a skillful and judicious person, who is able also to use other tests in corroboration of its disclosures, it may be of some service. Any dealer in or maker of scientific instruments, or dairy implements, could furnish a trustworthy lactometer and cream gauge. We could hardly advise you to purchase at present Short-horns of pure blood for dairy purposes, with a view to profit. The cost of cows of a good milking strain would be such as to preclude any profit, with milk at nine cents a gallon. At present, this class of stock is held and dealt in by breeders only, and is therefore scarce. It is in course of distribution, and by and by, as its numbers increase, it will become reduced in price. But it has a large field to extend over, and until that becomes fairly occupied, we may expect to see the best strains of Short-horns retain a value which places them beyond the reach of a dairyman. However, it is probable that by searching amongst some of the breeders in Colorado, a young bull of good character could be picked up which might be crossed upon Ayrshire or extra good native cows with benefit. The Ayrshire and Shorthorn cross has produced some excellent dairy cows. In selecting a bull for this purpose, one should be chosen from a heavy milking dam, and having fine bone, a fine neck, wide chest, a loose mellow skin, and fine hair; the heavier beef-producing qualities may be ignored in a bull for dairy purposes. Butter at 35 cents a pound is more profitable than milk at nine cents a gallon, in a dairy of good butter-yielding cows.

Recent Discovery of Guano.—A short time ago, some extensive beds of guano were discovered in Peru, to the south of the Province of Tarapaca. An examination of the beds has recently been made by two surveyors, which were sent out by the Central Board of Engineers of Lima, Peru. Their report is of very great interest, as it shows that several large beds of guano, of excellent quality, exist in that locality. Those which have been surveyed, are estimated to contain nearly eight million tons; one of them alone contains five million tons of fine quality. These fortunate discoveries not only remove all fear of a present failure in the supply of guano, but indicate that there are yet other undiscovered beds in existence, which will provide a practically inexhaustible supply.

Peach Borers.—"L. F. M.," Piedmont, Mo. We doubt if coal oil or any other application will destroy the borer, when once at work within the tree. The only sure treatment is to kill the grub by some mechanical means. In the peach districts of Delaware and Maryland, "worming" is done as soon as the crop is off, as then there is a plenty of labor at hand. Each person is provided with a hoe, to remove the earth from the base of the tree, a strong knife, to cut away the bark and wood, to find the channel of the borer, and a wire or whalebone, to pass into the hole, and kill the invader. As the borer often enters considerably above the base of the tree, we can not see how coal oil, applied to the roots, will reach it.

Clean Seed Wheat.—"H. K.," Green Bay, Wis. Our course to procure seed free from weeds, is to go through a portion of the field, and gather every head of cockle and other weed that could possibly be harvested along with the wheat. This portion of the grain should be kept separate from the rest, and thrashed by itself, and kept expressly for seed. The usual careless habit of throwing the screenings from the grain into

the barn-yard, is the source of a great part of the weeds upon farms. All such trash should be either burned, or, if mixed with light grain, ground, and fed to hogs or fowls.

Old Brood Mares.—"Horseman," Orange Co., N. Y. There have been many cases of mares breeding after the age of twenty years. The famous Lexington was foaled when his dam was twenty-three years old, and the dam of Dexter now has a foal at foot, and she is in her twenty-seventh or twenty-eighth year. The mare Katydid is recorded as having a foal at twenty-eight years.

Fine Mushrooms.—The finest exhibition of mushrooms we ever saw, was seen a few weeks ago at the seed-store of James Fleming, 67 Nassau street. For size, abundance, and excellent shape, they were truly remarkable. We learn that they were raised by Samuel Henshaw, gardener to J. C. Green, Esq., New Brighton, Staten Island, the same successful cultivator, whose improved Mignonettes was mentioned last month. Mr. H. has a cellar arranged for mushroom growing, and we hope he will give our readers an account of the method, which produces such fine results.

Grape Scissors.—There have been several contrivances for conveniently picking fruit, without

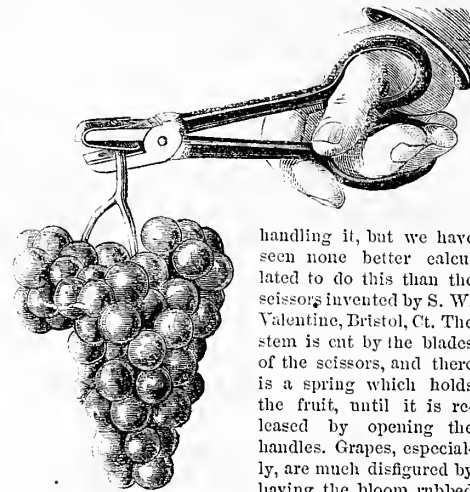

handling it, but we have seen none better calculated to do this than the scissors invented by S. W. Valentine, Bristol, Ct. The stem is cut by the blades of the scissors, and there is a spring which holds the fruit, until it is released by opening the handles. Grapes, especially, are much disfigured by having the bloom rubbed off by handling, and this will allow the picking to be done without touching a berry. The engraving shows the form of the scissors.

Rhubarb and Tomato Wine.—"N. M. L.," Iowa. Almost any fruit or vegetable juice, mixed with an equal measure of water, with about three pounds of sugar to the gallon, and allowed to ferment, will form an alcoholic liquid. That anything bearing the remotest resemblance to wine can be made from either tomatoes or rhubarb, we do not believe. We have seen many samples, which in the opinion of the makers were good, but in our opinion very poor stuff.

Breaking for Hedge Rows.—"C. C. R.," Barton Co., Kansas. The ground for a hedge row should be broken in August. The strip broken should be at least six feet wide, and should be plowed deeply, with an open furrow in the center. Just before frost, the ground should be plowed back again, filling the dead furrow, and turning one more furrow of sod upon each side. Early in spring, the ground should be plowed once more, throwing a ridge in the center of the row, upon which the hedge plants should be planted. The hedge will thus stand in the center of a ridge, not less than eight feet wide, and with a deep furrow upon each side, for drainage. If fire is feared, a fire guard, of six feet wide, had better be plowed around the fence. The fence row must be kept well cultivated.

How to Make a Root House.—"W. J.," Reed City, Mich. Full directions for making root cellars of logs, were given, with illustrations, in the *Agriculturist* for October, 1873, page 376.

As to Pickles.—"Gardener," Albany, Ind. The usual market value of cucumbers for pickles is about the same all over the country. We have known but little difference between the prices in New York and the Western cities; if any, the prices in the West are higher. In New York, pickles come to market packed either in brine or vinegar, in barrels of forty galls. and half barrels. The barrels hold 1,000, 2,000, or 3,500, according to size, and are now worth \$14 to \$16. The half barrels hold 500, 600, 800, or 1,000, and sell for \$4.75 to \$6.00. The favorite size are the smaller ones, of 600

to the half barrel; these bring \$5.50 at the present time. The fresh gathered "pickles" are generally sold to persons who pack them, at \$1.25 per 1,000. The packers put them down in brine, and sometimes keep them two years, when the demand is dull. The value in Chicago or St. Louis is about \$16 a barrel, generally. An article on pickles will be found on page 262.

Draining "Sticky" Land.—"J. N. Z.," West Charlotte, Ohio. Black sticky land, with a clay subsoil, would undoubtedly be improved by draining. Much of the sticky character would probably disappear after it is freed from water, and it would become looser and mellow. This effect has repeatedly been realized by draining, and it is one of its most marked improvements. At all events, it would be safe to experiment upon a strip at the lowest part of the land first.

Disease amongst Lambs.—"J. E. G.," West Falmouth, Mass. We know of no disease amongst lambs, attended by such symptoms as soreness of the eyes, and swelling of the eyelids, unless it be what is known as ophthalmia. This is accompanied with considerable general disturbance of the system, as shown by a dry, hot mouth, loss of appetite, and suspension of rumination. The wool feels harsh, and the lambs keep away from their companions. It is probably due to poor keep, and when on a bare pasture, the flock is exposed to the reflection of light and heat, from the bare ground. Cold, damp, and exposure to cold winds, will also produce it. Immediate care is needed, to avoid ulceration of the eye, which frequently follows the inflammation. The lambs should be kept up in a dark stable, and a few drops of a solution of one grain of chloride of zinc, in an ounce of water, should be syringed into the eye four times a day. Rags, dipped in a mixture of a pint of water, and two ounces of laudanum, should be hung, by means of a string, around the head, so as to cover the eyes. A tea-spoonful of Epsom salts, dissolved in water, should be given to each lamb, and a quarter of a pound of louse-meal daily, would be a help.

Bees.—Some one at Dennisport, Mass., sent his letter without signing it. Had he given his name, we should have sent him Mr. Quinby's circular, which would have answered his questions.

The Dairy in the North-west.—"W. S. S.," Chautauque Co., N. Y. There is no risk whatever as to the quality of the product in dairying, in either Kansas, Nebraska or Minnesota. The native grasses of the prairies are abundant, and produce excellent butter and cheese. We have never seen anywhere else, than on these prairies, such high-colored or sweeter flavored butter or richer milk. The very common grass, with narrow leaves, known as *Bouteloua*, and which is frequently mistaken for Buffalo-grass (*Buchloe dactyloides*), is productive of very rich milk, and the best of butter. This grass does not disappear, as the Buffalo-grass does, when the prairies come to be occupied by settlers, and it would doubtless furnish the most valuable, although rather thin, pasture for a number of years, if indeed it would not be permanent. The late prairie grass is also nutritious, and gives a heavy crop of hay. The chief drawbacks are want of water and shelter, but the first exists only in some localities, and the other will soon no longer exist. Already there are abundant openings for cheese factories and creameries, and in many cases tempting inducements are offered by the farmers for dairymen to go in and erect factories.

Summer-Fallowing Prairie.—"M. A. C.," North Topeka. We would not summer-fallow a prairie soil that is rich in vegetable or soluble mineral matter. The chief object of summer-fallowing is to kill weeds, but they may be killed without it. Another object is to work up and expose a hardly used soil to the air and weather, to mellow it and improve its condition. But on a soil that is already in good condition, yet full of weeds, it would be just as well to let the weeds grow, and plow them under before they blossom. If the greater part of the seeds can be destroyed, by one or two plowings in this way, a great good may be done, and the land may then be put in fine condition for a fall wheat crop. But we would encourage the weeds to grow, and keep the ground well covered until it is again plowed, rather than keep it bare by constant harrowing. A well-cultivated corn crop would answer the same purpose.

What is "Pi"?—"E. W. C." The word "pi" means a quantity of type scattered irregularly. In the puzzles on the last pages of the *Agriculturist* it means letters out of their proper place in the words, and thus meaning nothing; the puzzle is to so re-arrange the letters as to make the words read correctly. This gives amusement to both children and old folks, and helps to make boys and girls think quickly

Health of Farmers.—The Massachusetts State Board of Health, in their fourth annual report, have a paper upon the sanitary condition of farmers, based upon the reports of the country physicians throughout the State. Evidence collected for 23 years past shows that the average length of the life of a farmer, in that State, is 65½ years. This is much longer than that of any other class of citizens. The class most nearly approaching farmers, viz.: out-door mechanics live only 52½ years on an average. But the almost unanimous opinion is that farmers might live much longer than they now do by exercising more care in choosing, cooking, and eating their food, in avoiding overwork and exposure to change of weather, and the use of foul drinking water. Their food consists too much of pork, pies, and saleratus bread, and cakes. The cookery is bad, and meals are eaten too quickly for good digestion when work hurries. More vegetables and fruit should be eaten, and more rest taken. More cleanliness as regards out-houses, sinks, and back-yards, should be observed, and more care taken to avoid leaving cess-pools, sinks, etc., nearer a well than 30 feet at the least.

Sale of Shorthorns.

The sale of the Forest Hill herd, property of J. H. Spears & Sons, took place at Jacksonville, Ill., May 27th, the forty-three animals bringing \$33,000. The bull Cherub 2d (one year old) was sold to Gen. Charles L. Lippincott for \$5,800, the largest price ever paid for a yearling bull. The cow Duchess of Sutherland was sold to Gen. Lippincott for \$1,600, and her bull calf to S. K. Reigins, Petersburg, Ill., for \$1,050. These were the highest prices paid. The purchasers were all residents of Illinois, Indiana, and Iowa, the majority of the animals remaining in Illinois.

It is stated that Mr. Geo. Robbins, who bid \$14,000 for the Second Duke of Hillhurst at Col. King's sale, did not come to time in making satisfactory "arrangements," and the bull remains in Col. King's possession. We understand that he has refused all offers to purchase it since.

The joint sale of the shorthorn herds of Messrs. Taylor, Pickrell, and Elliott took place at Decatur, Ill., May 28th. The Lonans of the Taylor herd sold well, Lonan 6th (bought by E. W. Miller, Lullu, Ill.) bringing \$2,110; Lonan 4th \$1,760 (to J. Nichols of Bloomington, Ill.); Lonan 5th \$1,300, to Claude Matthews, Clinton, Ind.; Lonan 3d \$1,100, to Emery Cobb, Kankakee, Ill.; Lonan 8th \$1,200, to Edward F. Iils, Springfield, Ill.; Oxford Duchess, \$1,025, to J. Nichols, Bloomington, Ill. The imported bull, British Flag, three years old, sold for only \$530, (cause, bad temper). The cows in the Taylor herd brought an average of \$850. The Elliott and Pickrell herd sold at an average of about \$300.

Notes upon other sales will be found upon page 259.

Swindling by Mail.

The mail trade of seedsmen, florists, and the like is now very large, and though from the nature of the case there is more or less delay and loss, yet it is on the whole a great convenience to dealers, and a great saving to purchasers. Among its disadvantages to the dealers is the fact that it allows of a considerable amount of small swindling, and there has grown up a set of knaves who systematically swindle them. Their mode of operation is generally to send an order, stating that the money is inclosed. The dealer finds no money, but the writer claims that he sent it, and it must have been lost, that he can ill afford to lose the sum, and appeals to the sympathy of the dealer, who, rather than have his customer suffer, usually sends the goods. These cases have happened so frequently, that the dealers have compared notes, and discover that the same parties play the same trick upon the prominent seed and plant dealers all over the country. The following, from a highly respectable seed firm in Rochester, gives an account of the operations of one of these correspondents, which will serve as a sample of the rest:

"Our first experience with this class of 'unfortunates' was with a party who has befooled his misfortunes in losses of money by mail for several years, with the greatest steadiness and persistence, and is not yet disheartened; he has repeatedly been rewarded for his style, which is 'childlike and bland,' by confiding seedsmen and is not yet satisfied.—Mr. Ross A. Bagley, of Big Creek, Forsyth Co., Ga. His first letters to us claimed a loss of \$10.80, which, being a man far removed from money-order offices, and unused to mercantile pursuits, he had sent us in all confidence; this also contained a proposition that we share his loss, as he was not able to bear it. We supplied promptly the full amount we authorize to be sent by mail at our risk, without registra-

tion, suggesting that his letter might have been registered at the post-office, and we could do no more. Again he pleaded, and again was refused, he closed the correspondence with an appeal, from which we quote: 'Send the chromo any way, if you sympathize with a poor man, who wished and tried hard to be a customer. I should have remitted you the money at the start, if I could have done so, but it is my misfortune to possess but few of this world's goods, therefore I could not possibly afford it. . . . It is not my intention to ask for more than is right. I do not think the fault lies with you, and if you can not send the chromos willingly, we will drop the subject.' Our suspicion was increased by the studied air of modesty and confidence expressed in this note, and a gentleman connected with our house remembered the name as one that figured in a transaction where a neighbor of ours in the same trade had suffered considerably from an attack of Bagleyism. We found Mr. Jas. Vick possessing a file of papers in the familiar chirography of Bagley, and that he had an experience similar to our own. Seeking further to know the probable extent of the business as done by this particular individual, we requested information from other houses in the same line, and the responses came promptly, and of similar tenor. 'Mr. Ross A. Bagley,' say Messrs. B. K. Bliss & Sons, 'has favored us with his patronage,' and proceed to give in detail a repetition of the familiar story of a loss by mail and a request for remuneration. Peter Henderson & Co. say that 'in 1873 that accomplished rural rascal, Bagley, of Big Creek,' had found them out, and bitten them, but not deeply, for which they are deeply thankful. Jas. J. H. Gregory has a matter of a few dollars, for furnishing Bagley with seeds the last fall and the present month. We also learn from Reising & Hexamer that he attempted to victimize them. It seemed to us that such frequency of misfortune should not be permitted to remain in obscurity, or a success achieved by such effrontery and low cunning be allowed to continue, and we present this case as one fit for exposure by the *Agriculturist*, to which other specimens of this new pest may be added by ourselves and other dealers. We do this as a protection to the trade, by giving timely notice to those who might otherwise suffer, and also warn any who might hope to escape detection in the 'ways that are dark and tricks that are mean,' by the pitiful littleness of the act.

CHASE BROTHERS & WOODWARD.

"Rochester, N. Y."

Bee Notes.—Advice to Beginners.

BY M. QUINBY.

Cattle, while running wild, and receiving no attention from man, give him but very little towards his support. But after studying their nature, and cultivating it, he has from them, in addition to the hide and tallow, many of our choicest luxuries—milk, butter, and cheese. Bees, in their wild state, furnish wax, bee-bread, and a little honey mixed with it. With the same attention to their cultivation, that we give our cattle, we can improve their products equally as well. Cattle thrive and grow when running wild; so do bees, in their native state; but such thrift satisfies only those who are ignorant of what may be done. Such persons maintain that the nearer we follow nature, the more certain we are of success; but it must be admitted that this course is not always satisfactory. Fruit will grow without assistance from man. We prune, to allow light, heat, and circulation of air, our object is not to prolong the life of the tree, but to promote the production of fruit. So with

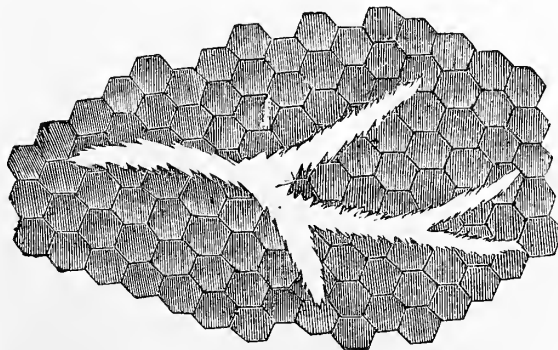

TRACK OF THE MOTH-WORM.

bees; for the greatest success, attention must be given to a thousand little details, that have been too much neglected; and the person that judiciously attends to the greatest number of these, will succeed the best.

Since the introduction of the Italian bees, it has been discovered that they drive off the moth worm, much more effectively than the black bee. Yet when these are

not very strong, considerable inroads are often made upon them, and much time is consumed in mending the mutilated comb, and replacing brood that has been destroyed, making all the difference between a handsome profit, and nothing at all. In such case, the person who knows nothing of bees, would complain that they did not pay, just as he would if he took no care of his cattle, and expected a first-rate yield of milk, butter, and cheese. We should understand that the moth, having a burthen of eggs to deposit, seeks a place for them, and finds it, usually in some weak hive, and that the young, when they hatch out, will take the sustenance near at hand. Wax-comb is their natural food. The moth is active in a temperature so cool, that bees exposed to it will move but little, but creep close together, for mutual warmth, leaving a part of the combs bare. There the eggs of the moth will be deposited. As soon as the weather is warm enough for a few days, or the air is warmed by the bees, these eggs hatch. No mature moth lives through the winter. The egg or the worm will live in a moderate temperature, and mature in warm weather. When the female has her eggs ready, they must be deposited somewhere. If every hive is strong enough with bees, to cover the combs, they will not be allowed inside. In such a case, the eggs are left near the entrance of the hive, in some crevice, or where the bees, in passing over them, will attach some of them to the little pellets of pollen on their legs, and being small, they are packed with it in the cells. When the hive is warm, there is where they hatch first. Some persons have imagined that the moth, when it can find no other place to deposit eggs, visits flowers covered with farina, and leaves them, trusting to the bees to convey them to the hive with the pollen. I have not room to give all the indications of this, but I hope closer observation will decide whether it be so or not. In the humid atmosphere of the cluster in the hive, the moths' eggs hatch. If there is brood enough to consume most of the pollen, as brought in, the worms, as they hatch, are carried out, and little harm is done. The worm, when not removed, commences eating the waxen comb that surrounds it, making a passage large enough for its body, and spinning a silken gallery, inside of which it travels. When the colony is moderately strong, and the brood of the bee has changed to chrysalis, and is sealed over, the head of the bee's chrysalis does not touch the sealing, by near an eighth of an inch. Over the heads of these bees the worm travels, consuming the sealing and ends of cells, and spinning the gallery, to defend itself from the bees. Now is the time to assist the bees, before the worm has matured. Without the movable comb-hive, nothing of the kind can be done. When the worm has its growth, and has destroyed perhaps a thousand cells, and maimed or killed as many bees, it leaves the combs, and spins a cocoon, in which to repose for a fortnight or so, to change from a crawling worm to a winged insect. They may be found in crevices around the bottom, or outside, which are often not large enough to admit their body, though they seem to have no difficulty in biting away any soft wood, till the dimensions suit them. Not one moth ought to be allowed to mature, to lay eggs for a future progeny. Take advantage of their helplessness now, and destroy them. When allowed to arrive at this state, we have neglected one of the advantages of the movable comb-hive, and of the new method of applying smoke to keep the bees quiet. Examination should have been made long before this. In the middle of some warm day, when most of the bees are at work, quietly take off the top of the hive; have the smoke ready, of course; the day may not be so very fine, and you will find necessity of using it more; take off boxes, if any are in the way.

set them down, to prevent crushing the bees; now take out the combs, until you find sealed brood. If necessary, put on glasses, to be able to look closely, and if worms are at work, you will see a mark much like that shown in the engraving. With the point of a sharp knife pick this off till you come to the worm, which is to be dispatched. Perhaps it is not half its full size yet, and half the mischief it would do is warded off. I expect ladies to do this more effectually than those of the other sex, who are in the habit of doing what they think nobler work. It is a small matter to kill a moth worm; so it is a small matter to save a kernel of wheat. An accumulation of small matters is important. When the hive has but a little honey, and the moth's eggs hatch near the bottom of the cell, the worm hitches its way through the center of the comb, crowding the young bees outward, which does not immediately destroy their life; but the worm, in spinning its gallery, attaches its web to legs, wings, etc., of the bee, holding it so that it can not leave the cell when it has matured. They may be seen with their heads protruding, unable to emerge. As such bees are worthless when helped out carefully, it is well to cut them out, and find and destroy the worm or worms.

Strong stocks only are safe. I will not repeat now all the directions for securing strong stocks, but only add that every worm, small or great, should be thoroughly crushed whenever found, and one point towards strong stocks is gained.

Cabbages as a Field Crop.

The value of the cabbage as food for stock is rarely considered. Yet as a fodder crop to be consumed in summer when the freshness of the pastures is past, or as green winter fodder for young stock, fattening stock, milk cows or sheep, we know of none better. The value of the cabbage as compared with other fodder, known to be of the greatest excellence, may be seen by the following statement of the composition of the various substances here mentioned: for instance, there is in 1,000 parts of

	Water.	Ash.	Pot. ash.	Lime.	Phos. phoric acid.	Soda.	Mag. nesia.
Green clover	800	13.4	4.6	4.6	1.3	0.2	1.6
Green peas	815	13.7	5.6	3.9	1.3	—	1.1
Sugar beet roots	816	8.0	4.0	0.5	1.1	0.8	0.7
“ leaves	840	6.5	1.9	0.6	0.3	1.6	0.7
Cabbage	885	13.4	6.0	1.9	2.0	0.5	0.4

Considering the excess of phosphoric acid, which is the most valuable of all the constituents of the ash, the cabbage is seen to be quite equal to sugar beets as a fodder, while this excess gives to it a special value for young and growing or milking animals.

Again if we compare the amount of valuable organic matter contained in clover and cabbage, we find the following, *viz.*, in 100 parts of

	Water.	Albuminoids or fresh forms.	Carbo-hydrates or fat formers.	Fat.	Crude fiber.
Clover	80	3.3	7.7	0.7	4.5
Cabbage	89	1.5	6.3	0.4	2.0
Turnips	92	1.1	5.1	0.1	1.0

Thus although cabbage is not so nutritious as clover, yet the large amount of water it contains makes it a valuable fodder for winter when given with dry food, and it contains a very small portion of crude indigestible matter. It is, however, considerably more nutritious than turnips. The carbo-hydrates consist mainly of starch and gum. These substances are largely consumed in the respiratory process and help greatly to maintain the natural heat of the animal. As a winter food, therefore, the cabbage is seen to possess a high value, being superior to turnips and only slightly inferior to clover. From our own experience with it we consider it the very best food for ewes previous to and after lambing, as it causes a large flow of milk; and also far better than turnips, because no cutting is necessary and there is no danger of choking. The same advantages apply to it as feed for milk cows. For its culture considerable previous preparation is necessary, and for a crop for next season it is not too early now to begin to prepare the seed-bed. One great advantage of this crop is that a succession may be grown and an early crop may be ready for use in August, at which time it will be found of the greatest value for cows that are in milk. For this early crop the plants must be grown in the fall and wintered over in cold frames. The bed for the plants should be chosen in a dry, warm, sheltered place, and the soil should be carefully dug over with the spade or the fork, and made fine and mellow, and rich with well-rotted manure. For each acre of crop a bed of two square rods will be sufficient, upon which space one pound of seed should be sown. Drill sowing will be found more convenient than broadcast, as it will be necessary to keep the bed clear from weeds and the hoe can be used

between the drills. The seed should not be sown until the end of August or early in September. We have found the large Drumhead the best for this early crop, as it is very hardy and upon rich ground comes forward quickly in the spring and grows to a large size. Heads weighing twenty pounds and over are not uncommon in a field of this variety. When the plants are about four weeks old it is best to transplant them to the spaces between the drills, by which they are checked in their upward growth and make more stocky plants with more spreading roots. The frames may be made by placing boards upon their edges between the rows about four feet apart, and nailing strips to hold each pair of boards together. The strips may be nailed about three or four feet apart, and loose boards laid between the strips to complete the covering. The loose boards may be removed during the days when the weather is not too severe, to give light and air to the plants. Upon very cold nights straw or coarse hay may be heaped upon the frames for protection.

The ground for this crop may be a corn or oat stubble plowed in the fall and manured well with ten to twelve two-horse loads of fine manure directly upon the plowed ground. The soil and manure should be mixed by a thorough harrowing or working with the cultivator, and then lightly cross plowed and left rough until spring. In spring, as early as possible, the ground should be harrowed level and marked out into rows three feet apart. A dressing of 200 pounds of fine bone-dust, superphosphate of lime, or guano spread in the rows will be found of great benefit. The plants should be set out two feet apart in the rows, and if troubled with the flea they should be dusted over with fine dry-slacked lime or soot. Clean cultivation is needed. A later crop may be made from plants sown in a hot-bed in March and planted out in May and June. For this crop we have found the Early Winningstadt an excellent variety, and growing to a good size. The late crop will be raised from seed sown in an open bed in May and planted out in July, and the Marblehead Mammoth or the Drumhead are probably the best varieties. If a piece of clover sod can be plowed and well manured early in this month, it will pay to purchase plants from the seedsmen if they have not been prepared at home. A good clover sod turned under has yielded us an excellent crop, and we have also raised a good crop by planting cabbages between the hills of corn and working them with the hoe. For these late crops and such a catch crop as that raised with corn we have found Peruvian guano or fish guano the best fertilizer. With a small handful of fish guano with every plant we have raised some good cabbages in a cornfield; but where a piece of ground can be specially devoted to them it will be found the best, although where it can not be had we would by all means raise what we could in every available spot, either with the corn or in vacant spaces amongst the potatoes. Over 7,000 plants may be raised upon an acre, and if by careful cultivation and liberal manuring heads of an average weight of six pounds only are grown, there will be twenty tons of most excellent and healthful fodder. Such a crop is by no means beyond the range of probability where the proper attention is given. We know of few crops which return a greater value for the labor expended, and it is one which stands heat and drouth better than turnips and equally well as mangels.

Ogden Farm Papers.—No. 53.

I have had an unusual amount of correspondence lately concerning land drainage, and there is evidently a decided revival of interest on the subject among farmers in various parts of the country—enough to justify a repetition of some points which are to be found in detail in the books on draining.

To begin with, there is no special charm in burned clay which will make wet land dry, and poor land rich, by the mere effect of its being buried a certain number of feet below the surface. In fact, the *material* in itself has nothing whatever to do with the effect of a drain, so long as it remains good. What is needed is an open channel, at the proper depth, through which water can find its way; having a continuous fall, so that it will be easier for the water at every point to run off through the opening than to soak away into the ground; and placed at a sufficient depth to leave enough dry soil above it for crops to grow to the best advantage. If such a channel exists it makes no difference what means have been used to obtain it. While it exists and is kept open from end to end, it will answer all the purposes of a good drain, whether it is made of tiles, of stonework, of gravel, of plank, of brush, or of any other material. A drain made by a mole-plow, so long as it remains a drain, is just as effective as though it were laid with the best tiles.

The considerations which should decide us in selecting the kind of drain to be used are *cost* and *durability*. The best, and in the end the cheapest, drain—where tiles are accessible at reasonable cost—is one properly laid with a good quality of small round tiles, having collars or sleeves to keep the pipes in line, and to increase the facility of entrance of the water. Such a drain is practically indestructible, and should last as long as the land itself. Where good gravel can be had on the farm, an excellent drain may be made by digging a narrow ditch and filling it to a depth of six or eight inches with gravel from which all stones over an inch in diameter and all fine dirt have been carefully screened. A drain made in this way will last almost indefinitely, and will be comparatively inexpensive. Brush laid in the bottom of a wider ditch, well tramped down, and covered with inverted sods before the earth is thrown in, will often last for many years and do good service. Poles and board trunks are also pretty good.

Stones are a favorite material, and it is possible to make a good and permanent drain with them—but they have the disadvantage of being very costly. It is a quite common opinion that tiles are more expensive than stones. I should say that wherever the smallest tiles can be laid down on the farm for \$50 per thousand feet it will be cheaper to use them than to use stones, although these may be immediately at hand. A ditch for a tile-drain requires certainly not more than three-fifths as much digging and back filling as one for a stone drain, and the cost of collecting, handling, and placing the stones will usually be nearly if not quite as great as the cost of tiles—it is often more. Because the stones are procured and put in place without the actual outlay of cash, the expense is not always felt; but if it does not cost money, it does cost money's worth, and it would often be an economy to work out by the day and use the wages to buy tiles rather than to spend so much labor in hauling, preparing, and handling stones.

Good gravel, prepared as above stated, is often

cheaper than tiles, and it is better than stones. In making stone drains there is a preference in favor of using broken or small stones rather than to lay what is called a "French" drain, or a drain with an eye, because the latter requires the water to flow over an earth-floor, which it washes more or less according to the character of the soil, often undermining and displacing the stones which form the eye, or washing earth away from one place to deposit it in another to form an obstruction. Furthermore, surface water often breaks through from the top of the drain, carries dirt and rubbish into the channel to choke it, and helps to disarrange the stones. In using any other material than tiles, it is better to have a drain through which the water will *trickle*, than one through which it will *run* in a copious stream. This is the reason why a drain made with gravel or small stones is better than one made with large stones. It is better because less liable to become disturbed and made useless. One obstruction makes all the drain above it useless—often worse than useless—from the water accumulated in the upper part of the drain breaking to the surface at the obstructed point, and making a considerable tract springy and unfit for the production of good crops.

Another point connected with the draining of land often receives less attention than it merits. So much is said and thought about under-draining that there is too much disregard of the less important surface draining. Some soils are so tenacious that, no matter how well they may be underdrained, they will not allow the water of heavy or long-continued rains to pass through them so rapidly as it should do. In all such cases there should be surface gutters—more or less wide—to allow surface waste to pass off at once. These gutters should be always kept in grass, in order that the ground may not be worn away by the current.

It may be accepted as a principle that all farming land should be freed from the presence of excessive moisture beneath, and of surface water at the top. This is absolutely necessary to the economical cultivation of anything but rice and cranberries. At the same time, the work may be done much more cheaply than is usually supposed, and the exercise of a little common-sense will show that the desired result may be obtained more directly, more simply, and more cheaply than by the course often adopted. Many think that they must skirmish with soil water, coax it to run where it is not inclined to, circumvent it, attack it with "hering-bone" drains or "gridiron" drains, or apply some other "scientific" means to get rid of it. In draining, as in everything else, the scientific way is the simple, straightforward, practical way. The end to be accomplished is to take water from where it does harm, and lead it to where it can do no harm, and the natural law on which the whole process is based is this: Water runs down hill, and straight down the steepest slope of the hill. Consequently, if we wish to remove the water from a certain tract, we should not carry it diagonally, nor indirectly across the slope of the ground, but straight down the steepest descent, just where it would run had it its own choice. It is often required to collect the water of a number of lateral drains and lead it toward a convenient outlet, and to do this by following a line diagonal to the slope of the land, but the laterals themselves—the real drains—should run in the direction in which the water itself would run were it flowing over the surface. The reason for this is that this is the natural way

for it to flow, and that if the drain is laid in this direction, the tendency of the water will be to follow it—while if another direction is taken, the tendency of the water will be to leave the drain and seek the more direct fall. If the land is made wet by a spring, the proper plan is, not to go around Robin Hood's barn to cut the spring off; but to "hit him straight in the eye." Take the spring where it is and as it is, and tap it at the point where it accumulates all its water—then its entire removal will be certain. Any other course will be more expensive and less effective. Springy hill-sides must be treated on the same principle: strike straight and deep into the water-bearing stratum, and give the water an easier and lower vent than it finds at the surface, then carry it by the most direct route to the bottom of the hill.

To drain a wet place of a few rods, it is not necessary to underlay it with a cobweb of drains; one drain cut quite across the whole width of the wet ground will often prove sufficient. It is one of the sources of expense in draining that too many drains are made. As a rule, if the complete and thorough drainage of the whole land is not needed (and often it is not), and if it is the chief object to bring the soil into good grass-bearing condition, the best course will be to drain the wet spots by as few drains as will do the work, to tap all springs which it is desired to get rid of, and to arrange for the complete removal of all surface water. Of course, the complete and thorough drainage of the whole land often is necessary. It was necessary at Ogden Farm, and the whole place is underlaid with tile drains, four feet deep, and forty feet apart; there are over thirteen miles of them. When work is to be done on this scale, the owner will take more comprehensive advice than could be given in a newspaper article; but it seemed probable that a few hints for men who do their own engineering, and much of their own work, would be as useful as anything that the past month and its letters have suggested.

The cost of tile draining—which for many reasons is the best wherever it is practicable—can not be exactly stated, for much, of course, depends on the character of the soil and on prices. In fair, solid clay, where not more than one-half the earth has to be loosened with the pick, a first-class tile-drainer, with proper tools, will dig, lay, and back-fill five rods per day, 4 ft. deep, 14 inches wide at the surface, and from 2 to 3 inches wide at the bottom. He takes out 45 cubic feet of earth for each rod of drain. An ordinary laborer would insist on a much greater width of ditch, (with ordinary tools he would need it), and if the drain were to be made with stones, a greater width would be necessary. Such a workman making a ditch for stones, say 4 feet deep, 24 inches wide at the surface, and 16 inches wide at the bottom, would throw out 110 cubic feet of earth for each rod of drain. The cost of twice handling the extra 65 feet of earth would be generally enough to pay for tiles, unless the location were very remote from a factory; it would often be much more than enough. The relative difference is equally great in making drains only 3 feet deep.

One other matter in which it is common to make a mistake, is in the size of tiles used. If of good form, and with well-fitting collars, 14-inch tiles, laid with a fall of six inches in 100 feet, are ample for the removal of the rain-fall on an acre of land, and—to skip intermediate details—6-inch tile is sufficient for 40 acres. Of course, spring water (which is the rain-fall on

other land brought underground to ours) will affect this rule, but less than is often supposed.

Now and then, by way of encouragement, I look back over the history of some of our Jersey cattle investments, and trace the directions in which particular strains of blood have been disseminated. Here is an instance: In the winter of 1867-8 we bought from Mr. Hartman Kuhu, of Philadelphia—together with some others—a young heifer to come in the next summer with her first calf. The price paid was \$350. She arrived here safely, and did well. Her first calf was a bull, and in those days we did not consider a bull calf worth raising. The next (1869) was a heifer, Nora; the next (1870) a bull, Nebuska, used here as a yearling, then sold for \$200, and went to Mississippi. In August of that year Nelly was sold for \$750, and went to Massachusetts. In 1871 Nora had a heifer calf, Noreina; in 1872 a bull, Norajah, sold for \$100, and went to Connecticut; in 1873 a heifer, Donora, sold for \$175, and went to Tennessee; in 1874 a heifer, Belnora. In 1873 Noreina had a bull calf, Belnor, sold for \$100, and went to Jefferson County, N. Y. She will be due to calve again in a few days. Nelly, Nora, and Noreina have always been very profitable from the time of first calving. The sales named above amount to \$1,325, and we have still on hand Nora, Noreina, and Belnora. This result, in a little more than six years, from an investment of \$350, is satisfactory. We have others whose report would be quite as favorable.

This number will reach its readers too late for the beginning of the haying—too late for the bulk of it, where farmers understand their best interests—but there will still be a great breadth to be cut, and it is not too late for the repetition of an oft-made suggestion—which I repeat, because my own experience has convinced me of its great value. There is but one *best* way of doing anything, and the *best* way to make hay is the following, or if it is not, pray let us have information as to a better one: 1. Start the mowing machine after five o'clock in the afternoon, and do no cutting after the dew is off of the grass in the morning. 2. On the first clear morning after the cutting, but not until the dew is well off, start the hay-tedding machines—as many of them as can be got hold of—and keep them going without unnecessary intermission until the last lock is hauled into the barn, or until the dew begins to fall in the evening. The more constantly the hay is stirred the better it will cure. 3. Begin hauling early enough on this same day to get all that has been cut safely into the barn or stack. By this process the crop will be put in in the best possible condition, and though it may *look* too green it will be quite safe to keep (if it has been well stirred), and will "spread" better than if made by any longer process. Should rain follow the evening cutting, no harm will be done, for the grass will not have its nutritious parts leached out until it has first been wilted.

Carriage and Pigeon House.

"A Subscriber" asks for a plan for a carriage-house with an apartment above for fancy pigeons. We give herewith a plan with elevation of a building adapted for these purposes. Fig. 1 shows the elevation of the building which has a carriage-house and stable for two horses below, a hay-loft above, and a pigeon-house above the loft. An lighting board runs

around the outside of the pigeon-house above the roof of the loft, and a ventilating cupola

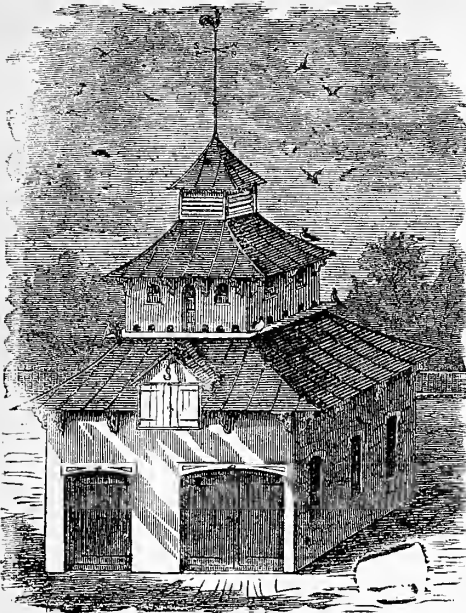

Fig. 1.—CARRIAGE AND PIGEON HOUSE.

is placed upon the top. The arrangement of the interior of the stable is shown in fig. 2, and that of the pigeon-house in fig. 3. The nest-

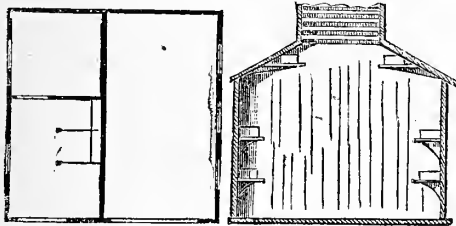

Fig. 2.—PLAN.

Fig. 3.—SECTION.

boxes are placed upon shelves around the walls, and a trap-door in the floor near the wall gives access from the hay loft.

Natural Pastures.

We recently had the pleasure of visiting a farm in Litchfield County, Ct., where a large portion of the pasture land had never been plowed. There was at least one hundred acres, containing a good variety of soil and exposure, that had received no care from the hand of man since the forest was cleared off a hundred or more years ago. Some of it was hilly and strewn with boulders, some quite smooth and available for the plow, and other portions moist and covered with coarse grasses and rushes. The present owner and manager is eighty-five years of age, and has been in possession for sixty years, and one of his hobbies is natural pasture. He has followed the raising of Devon cattle and Merino sheep nearly his whole life, and these have been the important crops sold from the farm. The pasture retains all the natural grasses that originally grew upon the soil. The surface mold formed by the decay of the leaves and stumps of the forest has never been disturbed or exhausted by tillage. The annual crops of grass have been consumed by sheep and cattle, and the most of the manure has been left upon the soil. The raising of cattle to sell for stock has this advantage over dairying. The cattle are left in the pasture through the summer, while the cows are brought up to the milking yard at night, and at least one half of the manure is left in the yard. Sheep are in the pastures

through the season, and their manure is quite evenly distributed. If there is any excess in any part it is upon the high ground and hill-tops, to which they generally resort at night, or when they are lying down. The portions of the pasture that are most exposed to washing and most likely to be poor receive the largest share of manure. The result of this treatment, in this case at least, is a complete vindication of the policy of keeping the plow out of land devoted to pasture. Everywhere there is a thick, heavy sod, and a good bite of grass, even upon the driest hill-top. There has been an increase in the capacity of the pasture to carry stock, and the feed is better now than it was sixty years ago. This man has attained a result by simple grazing with sheep and cattle, which others attain by expensive plowing, cultivating, and heavy manuring. May not the multitude of emigrants who are clearing away the forests in the new states and territories learn something from the experience of this old farmer? After the forest is cut away, and the trees and brush are burned, there is no need of raising wheat and corn several years to prepare the way for the grasses. If the grasses are not already there, the seed would catch readily upon the soft mold and ashes after the burning. The stumps would remain for a time, but they would not be in the way of sheep and cattle as they are in the way of the plow and the reaper. They would go to decay in a few years, and this decay might be hastened by burning after they were thoroughly dry. The ashes and mold would add to the riches of the soil and the luxuriance of the grasses. The thick, heavy sod, thus formed at little cost, would be a better investment than any bank or railroad stock. The cashier would not default. It could not be stolen. It could not be burned up. It would declare dividends while there were sheep and cattle to graze it, and a man to watch the herds and flocks. From what we have seen here and in other grazing districts of these natural pastures, we are convinced that a great deal of labor is worse than wasted in putting cleared forest lands into grass. CONNECTICUT.

Lolling of the Tongue.

We have had many inquiries as to a form of bit, best calculated to prevent lolling of the tongue in horses, and we now illustrate two kinds of bits, that are well designed to prevent this disagreeable habit. The principle upon which they are made, is to prevent the horse from getting his tongue over the bit. If this is prevented, the tongue is seldom thrust out at the side of the mouth. Figure 1 shows a bit, having an attachment at the upper side, and an extra ring, by which it is kept in its proper position. The tongue can not possibly be got over this bit. But we have occasionally seen a horse which would thrust the tongue out beneath the bit. For such a rare case, the bit shown at figure 2 is provided. The plate upon this bit swings readily, and whether the horse at-



Fig. 1.—BIT.

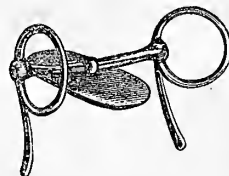

Fig. 2.—BIT.

tempt to carry the tongue out over or under it, it is turned, and prevents the movement. There can not possibly be any lolling of the tongue in this case. Both of these bits are made by Joseph Baldwin & Co., 254 Market street, Newark, N. J.

Binders for Sheaves.

The ordinary bands for binding sheaves are both wasteful of grain and time. A band that is ready-made, and which can be fastened in-

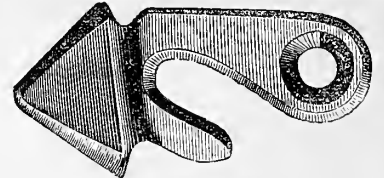

Fig. 1.—SHEAF-HOOK.

stantly and tightly, would be a great convenience. For binding corn it would be a great boon. We here illustrate two methods of making bands which are used by French farmers, and which would be found useful to us, inasmuch as they are easily made, quickly fastened, and hold the sheaves securely. Figure 1 shows the hook, which is best made of malleable cast

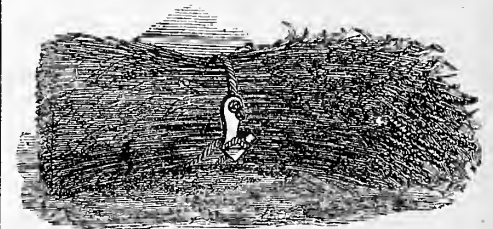

Fig. 2.—SHEAF BOUND.

iron. A cord is passed through the hole, and is knotted at each end. To bind a sheaf, the cord is passed around it and over the hook at the back, drawn tight, and then passed once around the tongue of the hook, and finally along the groove, and tucked in firmly between the straw and the hook, leaving the knotted end hanging loose. To unbind the sheaf, the



Fig. 3.—SHEAF-BINDER.

knotted end is pulled and the tie is loosened instantly. Figure 2 shows the sheaf bound with this tie. Figure 3 shows another and more simple tie, which is a long, narrow hook of stout wire, made with an eye at the end of the shank. This is attached to a cord knotted at both ends and at various places near that end which is distant from the hook. When



Fig. 4.—WIRE SHEAF-HOOK.

used, the cord is drawn tight round the sheaf and slipped into the hook, which holds the knot fast. Figure 4 shows another form of this tie, the catch for which may be made of strong wire, such as is used for fences.

Dutch (or Holstein) Cattle.

The engravings on this page are portraits of a Dutch bull and cow which took the first premium at the New York State Fair of 1873; they are the property of Gerrit S. Miller, Esq., of Highland Farm, Peterboro', N. Y. The bull, Rip Van Winkle, was imported in his dam in 1869, and is now four years old. The cow, Crown Princess, was imported from West Friesland in the same year, and is now eight years old. Her yield of milk in one day in 1871 was 74½ lbs., or about 34 quarts, and her average yield per day for six months was 50½ lbs., or about 23 quarts per day. Her feed was nothing but pasture during June, July, and August of this period. Mr. Miller

feeds his cows in spring six quarts of grain daily, and in fall and winter four quarts daily. We assume that this cow had the usual allowance during the other months than those mentioned, although we have not been informed as to that.

We are glad to have the opportunity of presenting the portraits of these two animals, because they are types of a breed of great intrinsic value and of great importance to our own dairy interest. The dairies of Holland have had a wide reputation for many years, and the Dutch butter and cheese have long been celebrated for their excellence. The Dutch cattle for generations back have been bred especially for their dairy qualities, but at the same time their large frames, well covered with flesh, have rendered them more than fair beef-producing stock. Some of the best qualities of the now fashionable Short-horns have been derived from the blood of the short-horn Dutch cows. The rich pastures of the alluvial fields of Holland have helped during all these years to build up a race of fine dairy cows prolific of milk, butter, and cheese, and which when they have be-

come no longer profitable for the dairy quickly take on flesh and fat, and yield an excellent quality of beef. The color of these cattle is white and black, their frames are large and well covered with flesh; their skin is fine, soft, and mellow, their constitutions are hardy and robust, they

possess the favorite points of dairy animals, are apt and hearty feeders, and arrive at an early maturity. Recently a bull of this breed was slaughtered in Philadelphia, and dressed over 1,600 pounds net weight of the choicest beef, portions of which sold in the market for fifty

butter of cows of various breeds, in which pats of butter were placed in a warm cupboard near a steam heater, and their behavior under these unfavorable circumstances noted, he says: "There was one sample of Dutch butter, one of Guernsey, seven of Jersey, and two of Ayrshire; a few days later another pat of Ayrshire butter was added. The Guernsey butter was very high colored; melting point 99°; had an oily rather than waxy look, but was very attractive; it molded in spots in about a month. The Jersey butters in about seven weeks were all slightly rancid; one sample lost its color in spots, the white spots left resembling tallow in color and taste; no butter flavor. The Ayrshire butters had lost all flavor, were poor, very poor, but scarcely rancid. The Dutch sample

the best preserved of the lot. This is another proof of the Dutch outranking the Ayrshire as a butter cow. The keeping quality of butter is certainly an important item in determining its value. As for the cheese qualities of the Dutch cow, if her cream and milk are so readily mixed, by stirring, it would give our cheesemakers but little trouble to secure the cream in the curd, as it is their custom to keep the night's milk in gentle motion to prevent the rising of cream. When comparing the Ayrshire and Dutch as dairy cows, it should be remembered that the Ayrshire has had a com-

paratively thorough trial in the best dairy districts of this country, and has been bred and improved here for many years; while with the Dutch improvement is just beginning. So far as my experience of four or five years goes, the Dutch have proved themselves equal to any, and are surpassed by no other dairy stock in the world. Not only is their yield of milk large, but the average proportion of cream it contains I have found to be at least 16 per cent." It would seem that Mr. Miller makes

out a strong case for his favorite breed, and the reputation of these cows in their native country will go far to support him in his claims. It can not be doubted that there is a large opening amongst our dairies for the introduction of cattle of such excellence as the Dutch cows.

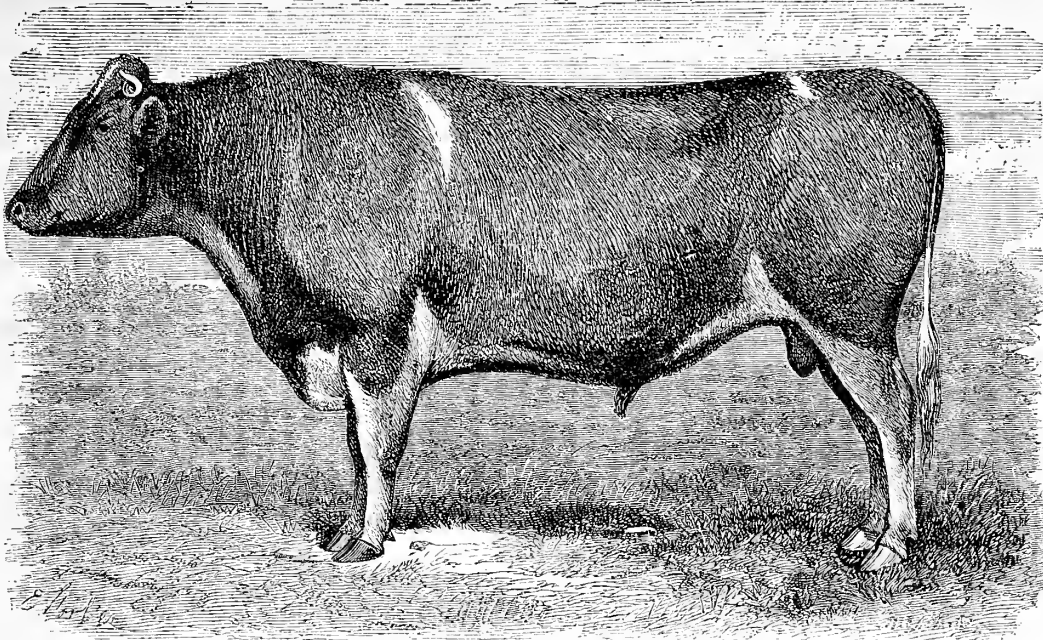

PRIZE DUTCH OR HOLSTEIN BULL.

cents a pound. The Dutch cattle, then, may claim to be considered as first-class dairy animals and as respectable beef stock.

But it is as dairy stock we propose to consider them, and here condense from a communication sent us by Mr. Miller the following remarks in reference to the comparative excellence of the Dutch and Ayrshire cows as set forth by Dr. E. L. Sturtevant in a recent lecture before the Vermont Dairymen's Association, already alluded to in a previous number of the *Agriculturist*. It is admitted by Dr. Sturtevant that the cream of the Dutch cow's

milk rises more quickly than that of the Ayrshire cow's milk. Mr. Miller therefore claims that, as a butter cow, the Dutch should stand before the Ayrshire of a butter family even. Further, referring to the experiments of Dr. Sturtevant as to the keeping qualities of the

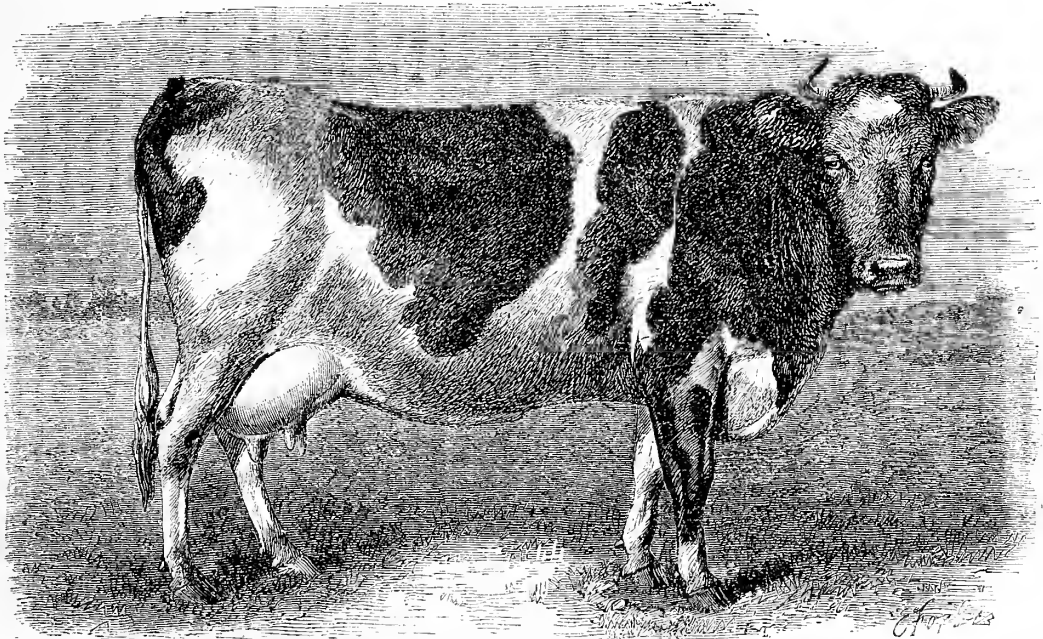

PRIZE DUTCH OR HOLSTEIN COW.

Walks and Talks on the Farm.—No. 127.

I had a visit the other day from four of the agricultural students at Cornell University. I enjoyed it very much. They were so genuinely enthusiastic and so anxious to learn. They got into the underdrains, examined the surface soil and subsoil, looked at the stones, the weeds, the crops, the fences, the implements, machines, horses, harness, whippetrees, pigs, sheep, grades, thorough-breds, lambs, and wool. It made me feel ten years younger to talk to such bright boys. One of them spent his last vacation on Dr. Hexamer's farm. Don't tell me that we have no young men who love farming, or that there is no call for agricultural colleges. There is a chance for Cornell to do something for agriculture yet. These young men speak highly of Mr. Roberts, the new professor of agriculture. I believe Mr. Cornell has always wished to give agriculture a leading position in the University. I hope he will yet do so.

"You have been predicting better times for farmers," said the Deacon, "but I don't seem to see them. Winter wheat looks miserable. Clover has been badly winter-killed. Old meadows are far from promising. The weather this spring has been cold and dry, and the crops have been put in late, and the prospects are that we shall have a light yield of oats and barley."

"This is a gloomy picture, Deacon," I replied, "but, admitting all that you say, I do not feel discouraged. When you say I have been predicting better times for farmers you do not quote me correctly. I have been predicting better times for good farmers."

The Deacon thought a moment, and then asked quietly, "What do you mean by a good farmer?"

This seemed a proper question to ask, but I knew the Deacon too well to suppose that he asked it with any other object than to get me into a corner. And so I thought I would touch the Deacon on some of his tender points.

"A good farmer is a man who feels that he was sent into this world to work and think. He has more faith in himself than he has in what some people call 'nature.' When the gooseberry saw-fly first made its appearance, he did not fold his hands and let the caterpillars strip every leaf from his bushes. He consulted the books, and found out that it was no new thing. He availed himself of the experience of those who had studied the subject. He set out some good varieties of currants in rows four or five feet apart, where he could keep the land clean and mellow with a horse hoe. He examined the bushes, and found hundreds of bead-like eggs glued to the underside of the leaves, and these he killed with his thumb and finger. He found, too, that the insect laid its eggs on the leaves of the young suckers. He cut off the suckers, and in this way not only killed thousands of eggs and young caterpillars, but strengthened the bushes by removing a large quantity of useless growth. He found that the lady-bugs came to his assistance, and he felt encouraged to persevere, and the result is that, while your old hedge-row currant bushes are used up, he gets a big crop of large currants that bring him \$5 per bushel. And so this insect, instead of being an injury, is in reality an advantage to him. He gets better prices and far greater profits than when he 'let nature take its course.' I use this only as an illustration of a general principle. The codling-moth

is destroying thousands and tens of thousands of barrels of apples in Western New York every year. A good farmer adopts means to hold them in check, and gets better prices for his apples than he would if there was no such insect. During the 'bearing year' he thins out his fruit, and the next year, when there is a light crop, he gets an average yield of fine fruit and big prices. It is the extra price and the extra yield that a farmer must look to for his profits. Take, for instance, an orchard of two hundred apple-trees, that produce 1,500 barrels of apples this year and 200 barrels next year. The crop this year is large and the fruit small, and it sells say for \$1.25 per barrel. Next year the fruit brings \$3.00 per barrel. It costs say 40 cents a barrel to pick, head up, and market the fruit, and 40 cents for the barrel. The returns are:

1874.—1,500 bbls. apples, @ \$1.25.....	\$1,875
Barrels, picking, and marketing, @ 80c.....	1,200
	\$675
1875.—200 bbls. apples, @ \$3.....	\$600
Barrels, picking, and marketing, @ 80c.....	160
	\$440

"On the other hand, suppose the orchard is in high condition, and instead of letting the trees overbear this year the owner thins out the apples and gets 1,200 barrels of choice fruit worth \$2.50 per barrel, and the next year 1,000 barrels worth \$3.25 per barrel. The returns are as follows:

1874.—1,200 bbls. apples, @ \$2.50.....	\$3,000
Barrels, picking, and marketing, @ 80c.....	960
	\$2,040
1875.—1,000 bbls. apples, @ \$3.25.....	\$3,250
Barrels, picking, and marketing, @ 80c.....	800
	\$2,450

"In the one case the returns in the two years from the orchard are \$1,115, and in the other \$4,490."

"But you do not know," said the Deacon, "that you will get \$3.25 per barrel for apples next year."

"Of course not, but I got it last year, and what has been will be. I am trying to give you my idea of a good farmer. What is true of apples and currants is equally true of other crops. I sold potatoes this spring at \$1.25 per bushel, hay at \$30 per ton, butter at 40 cents per pound, and good beef and mutton are so scarce that I judge, from what he brings us, our country butcher can pick up nothing but old Merino ewes and half-starved yearling heifers. A piece of good sirloin from a well-fattened three-year-old steer is a rarity."

"All this is true enough," said the Deacon, "but by the time we have anything to sell prices will be lower. I tell you, farming is a poor business, and if it was not for your fancy pigs you would not talk so cheerfully. If I could sell pigs at two months old for \$40 a pair I could make money by farming too."

"Now, Deacon," I replied, "that is what I call mean. Here you have been neighbor to me ever since I have had these pigs. And it was two or three years before I could persuade you to try the cross on common sows. Before this you had amused yourself and others by saying that they were too delicate for ordinary farm treatment, that they were too small for profit and too fat to breed, and, above all, that they were black, and that the butchers and packers would not buy black pork. My first litter of pigs were all killed but two. I felt discouraged, and all the consolation I got was, 'I told you so.' I took my pigs to the State

Fair. One of my neighbors was on the committee. 'I hate a black hog,' he said, and when the awards came out my sow was put last and a grade white sow first. The next time I exhibited I brought home half a dozen or more first-prize cards, but my best sow shortly after she came back from the fair was stricken down with paralysis and never recovered. 'Too fat, too high-bred, too delicate,' were the kind remarks I heard on every side. After this I had two sows due the same day. One had a litter of eleven pigs. It was a terribly cold night in March. I sat up with her myself until one o'clock, kept the sow and little ones warm by keeping them covered with a blanket. I raised nine of them. The next morning I found that the other sow had had ten pigs, and my men, not knowing how to keep them under the blanket, allowed them to get chilled, and finally carried them into the house in a bushel basket without any covering, and left them there squealing. When I got up, and took them back to the sow, they were too far gone, and every pig died. I have lost a good many animals in my time, but do not recollect ever feeling the loss so keenly as I did this—because it was sheer carelessness. Farmers all over the neighborhood lost a great many litters of pigs that spring from sows that were certainly not too fat or high-bred, but that did not matter. Mine died because they were too delicate. After this my luck turned. I had three sows that produced thirty pigs, and we raised every pig and sold them for \$25 apiece. They are scattered all over the United States, and have, so far as I have heard, given a good account of themselves. In that litter of nine that I saved during the cold night in March there were four sows. Two of them I sold, one to Mr. Weed of New York for \$100, and the other to Mr. Hardin of Kentucky for \$200. The other two I have yet. One we call Favorite and the other Rainbow. Neither of them bred until over two years old. Since then they have bred regularly, and have brought me in more money than any other two sows in the herd. I believe neither Mr. Weed nor Mr. Hardin had patience enough to wait for their sows to breed, and have abandoned the business. And you would do the same, Deacon. There is not one man in ten thousand who has the qualifications requisite for success as a breeder. My men who left the litter of pigs to die in the basket went into the woods to chop. It was what they were adapted for. It requires the patience and gentleness of a woman to take care of high-bred stock. Some time since a lady in Illinois wrote me that she was carrying on a farm for her fatherless children, and wanted some pigs. I sent her some, and if I mistake not we shall hear from her. We have all read of Lady Pigot's success as a Shorthorn breeder. I know a lady in Saratoga County who, without saying anything about it, is equally enthusiastic and skillful. Mark my words, Deacon, the coming farmer will be a woman."

Two years ago, J. A. W., of Center Co., Pa., wrote me that he wanted a pig to cross with his Chester-white sows. As he wanted a white breed, I recommended him to get a thorough-bred Suffolk. He did so, and now he sends me the weight of one of the pigs he killed when exactly one year old. He weighed the pig every week for the last six weeks. The smallest gain in any one week was 6 lbs., and the largest 20 lbs. His average gain during the six weeks was 11½ lbs. per week, or 1½ lb. per day.

His live weight was 386 lbs.; dressed weight, 354 lbs. This is a shrinkage of only about eight per cent.

L. R., of Tennessee, asks: "Why do you recommend wheat after oats? Why not wheat after clover? Is not the oat crop better to seed down with than wheat?"—Not in this section. Winter wheat is the best crop we have to seed with. Barley is our best spring crop to seed with; oats the worst. I was not aware that I had "recommended" sowing wheat after oats. I rarely, if ever, adopt the practice on my own farm. True, I sow wheat after oats and peas, but oats and peas together are a different crop from oats alone.

Mr. R. adds: "I hope you will excuse me if I say that I was sorry you remarked (in Walks and Talks for May) that wheat can be grown after wheat, corn after corn, etc. Not because I think that you are not right, but because a great many will make it an excuse to drop their established rotation."—I am not afraid to tell the readers of the *American Agriculturist* the truth.

"The rotation," continues Mr. R., "which I and others have practiced here with success is: Corn; oats; clover mowing; clover pasture; wheat. The wheat stubble plowed and subsoiled in the fall, hauling manure on it during the winter, and cross plowing in the spring. Then plant corn. We can not get a stand of corn on clover sod on account of worms."—If this suits the soil and climate and enables the farmer to clean the land to the best advantage it is not a bad rotation. It affords a capital opportunity to clean the land. You can plow immediately after the wheat is harvested, or perhaps, what is better, break up the surface with a heavy four-horse cultivator. You have three or four months to clean and mellow and aerate the soil. In Tennessee, too, I suppose land can be plowed more or less in winter. At any rate it can be plowed again in the spring and got into splendid condition for corn. This system has some of the features of my "fall-fallow." I would use it as a stepping-stone to something better. I would use it to thoroughly clean the land. But as soon as I got my farm clean I would sow clover with the wheat; mow it or pasture it one year and plow it up the next spring for corn. The worms would not be likely to give much trouble on a year-old clover sod, turned over immediately before planting. After corn, follow with oats or barley and seed down again. Mow the clover for hay and for seed the first year. Pasture the next spring; plow up in June or July; and sow wheat in the fall and seed down again.

I have a field I am going to serve in this way this year. It is a two-year-old clover sod. Was mown for hay and for seed last year and again for hay this year. As soon as the hay is off I propose to plow it carefully with three horses, and then roll and harrow, and afterwards keep the surface clean by the frequent use of the cultivator, harrows, and roller until the first week in September. Then sow on a barrel of refuse salt to the acre. Then drill in $1\frac{1}{2}$ to 2 bushels of Diehl wheat per acre, sowing at the same time in the drills with the seed 150 lbs. of superphosphate and 100 lbs. nitrate of soda. In the spring, seed down with a peck of clover seed per acre and 100 lbs. nitrate of soda and 100 lbs. plaster.

J. D. W., of St. Croix Co., Wis., wants to know how to use straw to the best advantage. "I purchased the farm last year," he writes,

"and there is in the stock-yard an accumulation of straw from the last ten years in all stages of decomposition, from pure muck to solid straw stacks. There is probably 500 loads. Which is the cheaper, to haul manure from town, $3\frac{1}{2}$ miles, where I can get it for nothing, or to attempt to make manure out of straw? I hate to burn the straw, as my neighbors do, but if I keep on as my predecessor did my farm will be all straw stacks."—I do not think I am capable of giving good advice on this subject. Thirty years ago or less, farmers in this section threshed their wheat in the field and afterwards burned their straw to get rid of it. This spring I saw the poorest kind of poor straw sold in the Rochester market for \$18 per ton.

"What of that," said the Deacon, "it would not have paid us to keep our straw until now."—Of course not, but it would have paid us to keep up the fertility of our land.

"But you are always saying that straw makes poor manure."—So it does when used alone. But in connection with clover hay, corn, bran, peas, and oats it can be used to great advantage. The most difficult thing I have to contend with in keeping so many pigs is to get straw enough for bedding. I could use four times as much as I grow. If J. D. W. will keep more stock, raise more clover, and sow less wheat he will find no difficulty in using all the straw he can grow. The straw and manure now on hand I would draw out at every leisure time and spread on the grass land. At the same time I would draw as much manure as possible from the stables in the city. It will certainly pay. J. D. W. gives a list of prices. Wheat, \$1.10; timothy hay, \$12 to \$14 per ton; potatoes, \$1.00 to \$1.25 per bushel; onions, \$1.50 to \$1.75; oats, 60c.; corn, 70c. With manure for the hauling, and straw burned to get rid of it, I would pile on the manure until the land was rich enough to grow 400 bushels of potatoes, 800 bushels of onions, and 100 bushels of shelled corn per acre.

W. F., Centre Co., Pa., wants to know which is best to cross with common ewes—a Cotswold or a Leicester. If he could get a pure-bred, old-fashioned, genuine Leicester, such as Mr. Sandy, of Nottingham, used to breed twenty years ago, I think he would be better than the Cotswold. But there are now no such Leicesters. The so-called Leicesters of the present day are as large or nearly as large as the Cotswolds, and I do not know that they are in any way superior. My own opinion is that the Cotswolds are good enough. I do not want any better sheep than well-fed grade Cotswold-Merinoes.

"This is true enough for the first cross," remarked the Judge, "but after that they degenerate."—I know this is the common idea, and it is true provided you breed from cross-bred rams and ewes. But if you continue to breed to a pure-bred ram you can continue to "grade up" with very decided advantage. I have now lambs with three crosses of Cotswold, and they are very strong and healthy. I do not think it will make much difference whether W. F. uses a Cotswold or a Leicester. The important point is to get the right sort of sheep, and to get one that is pure bred.

A. S. Tipton, of Howard, Pa., asks: "Do you know of a cheap and better steamer than the Prindle?"—While I think it would be easy to make a better, I continue to use my old Prindle steamer. It is safe, simple, and convenient. I have had it changed so as to burn

coal, and it is now far more effective, as we can keep up a hotter and steadier fire with less labor.

Steel Bars for Bells.

N. H. D., Fillmore Co., Minn., wishes a substitute for bells, which are very costly. He has read that steel bars have been used in place of a peal of church bells, at very little cost, and thinks, if this is true, that steel bars might be appropriately used for school-houses and farms. We believe the substitution of bars in place of bells for use in churches to any large extent has thus far only been proposed but has not yet been made. Yet as we have seen them frequently used in place of bells in mining districts to call the miners to work, there is no doubt of their fitness for farm and school-house uses. A bar such as is used for miners' drills, of octagonal steel, an inch in thickness and six or eight feet long, is bent into the shape of a triangle and



TRIANGLE AND STRIKER.

suspended at one corner by a string or wire. When this is struck with an iron rod the vibration produces a sound which may be easily heard at a distance of a mile. The weight of such a bar is about three pounds to a foot, and the cost of Pittsburgh steel, which is equally as sonorous as the more costly English, is about fifteen cents a pound. A bar six feet long, of three-quarter inch steel, would answer for farm use; for a school-house the steel should be $1\frac{1}{2}$ inch thick, and the bar should be nine feet long. In the engraving we have shown the shape into which the bar is bent and the proper shape of the striking rod. The rod should have a wooden handle, and when not in use may be hung upon the triangle. The bar should be heated in a blacksmith's fire and bent over the horn of the anvil to the required shape. The heated portion should be allowed to cool gradually, lest it might break off at the bend when rung in very cold weather.

Getting Out Swamp Muck.

At the request of several of our subscribers we describe a method of digging muck from a swamp which can not be entirely drained, and illustrate it with two engravings. Figure 1 represents a very common kind of swamp, one in a hollow with high ground all around it, from which it receives the drainage. Many swamps of this character have a layer of shell marl beneath the peat, which, as well as the peat, is of considerable value as a fertilizer. To procure either the peat or the marl is a work of difficulty, because the soft nature of the ground forbids the use of oxen or horses until it is drained and dried to some extent. To commence to dig the muck under such circumstances we would level off a portion of the hill-side on the edge of the swamp, making a road of as easy a grade as possible to the margin. Then a boat should be constructed such as is shown at figure 2. It is of pine boards, nailed very securely to side pieces of pine plank, and has a center board to strengthen it. The

seams are calked with tow and pitch so as to make it water-tight. If made nine feet long, four feet wide, and sixteen inches deep it will float with a ton of muck. It should have a pair of runners beneath it, so that it may be

now be deepened two feet more by commencing at the place of beginning and proceeding as before. The muck may be dug from the bank of the ditch with long-handled shovels if the bottom is not dry. By and by, as the ditch is

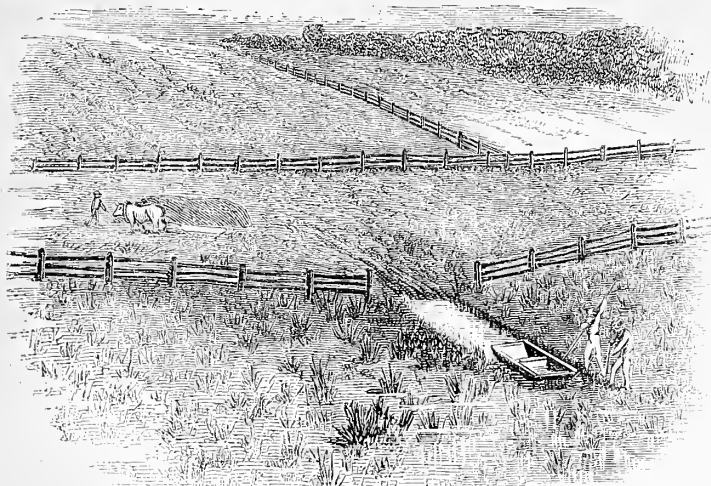

Fig. 1.—DITCHING A SWAMP.

readily drawn upon the ground when out of the water. At each side there should be a hook or eye to which a chain may be fastened. A strong eye should also be fastened on one side and at the bottom, into which the chain hook may be placed when wanted. All these are

and taking the supply of peat or marl from it, the water may be collected there and the swamp in a measure drained. When the boat is to be unloaded it may be drawn to the place where the muck is piled to dry; the hook of the draft chain is placed in the eye at the side,

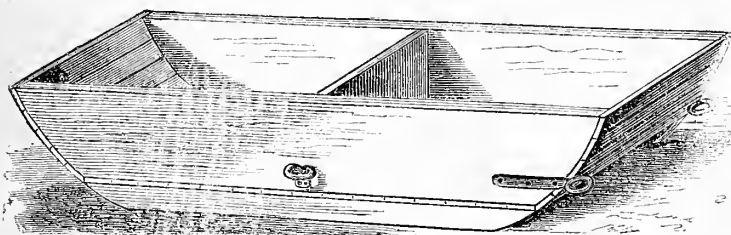

Fig. 2.—BOAT FOR GETTING OUT MUCK.

shown in the engraving. To commence the digging, the boat is hauled up to the edge of the swamp and loaded with muck, which is drawn to the place where it is to be piled. The heap should be as close to the swamp as possible, as, being so full of water, much labor is saved by hauling the muck home after it has dried for a few months. As the muck is dug

They are made, as shown in figure 3, of half-inch boards in strips 2½ or 3 inches broad for the bottom pieces and narrower ones for the two side pieces. A strap of leather passes across the toe of the boot and another buckles like the strap of a skate across the instep. With these one may stand or work upon very soft mud without sinking in it. In walking with these "pattens" it is necessary to carry the feet

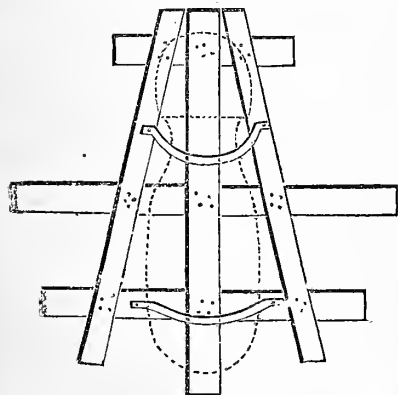

Fig. 3.—MUD PATTEN.

out, planks are laid down and pegged to the ground for a tramway, to enable the boat to be easily pushed into the swamp, which should be done by means of a hand-spike. By and by the muck will have been dug away sufficiently to allow the boat to float. Then the ditch is lengthened out until it is carried across the swamp. When the boat is loaded it is poled towards the landing-place with the hand-spike. If the ditch has been dug two feet deep it may

be deepened, the water will flow into the deep part and leave the shallow portion dry enough to work in. When one ditch is completed another may be dug, and in this manner a very wet swamp may be rendered dry enough for a meadow. The marl from the bottoms of the ditches will make an excellent dressing for the surface of the swamp as soon as it is drained. By excavating a pond in the lowest portion of the swamp

and the oxen or horses can easily upset it and dump the load. By reversing this method the boat is restored to its original position. A pair of mud "pattens" will be found very useful when working in the swamp.

They are made, as shown in figure 3, of half-inch boards in strips 2½ or 3 inches broad for the bottom pieces and narrower ones for the two side pieces. A strap of leather passes across the toe of the boot and another buckles like the strap of a skate across the instep. With these one may stand or work upon very soft mud without sinking in it. In walking with these "pattens" it is necessary to carry the feet wide apart, or a closer acquaintance with the mud may be made than would be agreeable. The value of muck alone as a fertilizer is apt to be overrated. We can not agree with Dana in his "Muck Manual," that a mixture of muck, salt, and lime is equal to barn-yard manure. This compost lacks some of the most valuable constituents of well-saved stable manure. But as a basis for a manure pile, or as an absorbent in place of straw, we have found it to be very valuable, and the ease with which it is spread in the field is one of its great advantages. With a plentiful supply of muck on hand one may use all his straw for feed, and thus greatly extend his resources.

An Improved Ox-Yoke.

J. S., Philippi, Jefferson Co., Pa., sends us two drawings of an ox-yoke, which we have

had engraved. He says this pattern, although very similar to that described in the *Agriculturist* of February, 1873, is better than that in some important points. The ends of the yoke are stronger, and less liable to split when made from this pattern than from the other, and

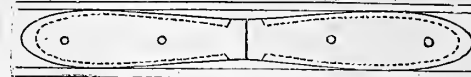

Fig. 1.—TOP VIEW OF YOKE.

neater in appearance. The bows are also better supported. This yoke is made from a block 8 x 10 inches thick, and preferably of basswood, cherry, or butternut, when used for light work, but where heavy work such as lumbering is done, soft maple should be used. The length of the yoke of which this is the pattern was five



Fig. 2.—SIDE VIEW OF YOKE.

feet two inches, but the length will vary according to circumstances. The distance between the bow-holes at the top is eight inches, but for light oxen the holes should be made to suit the bows, and the bows should be made to fit each ox just as a collar is made to fit a horse. When making a yoke, it is best to cut out a piece of board the exact shape of the pattern shown at figure 1 and lay it on the block to mark out by. The dotted lines show the amount of the chamfer upon the edges of the yoke. The portion between the bow-holes should be rounded off to very much the shape of the ball of the thumb, which is the most suitable to fit the neck of the ox.

A Prairie Stable.

A "New Subscriber" writes us from Platt Co., Nebraska, and although he does not live in a sod house, he compliments us upon our representation of one. He, however, has a sod barn, and wants to know how he may thatch it with long prairie grass. Very opportunely we have a communication from another of our friends upon the Nebraska prairies, describing his plan of building a sod barn, which



Fig. 1.—POSTS FOR PRAIRIE STABLE.

we here give with illustrations. His plan is as follows: Set four rows of heavy posts in the form shown at figure 1. For a stable 20 x 30 feet, five posts are set about 8 feet apart in each row. The first row, *a*, is 7½ feet from the next row, *b*; from *b* to *c* is 5 feet, and from *c* to *d* is 7½ feet. The outside rows should be 6 feet high in the clear, the inside rows 7½ feet. The posts are then joined at the top, lengthwise of the building, by strong plates. These may be laid in natural forked timbers or be firmly pinned to the posts. Rails are then laid about two inches apart upon the plates. Extra

posts are now placed at *e* and *f* for door-posts, and at *g* two posts are placed meeting together at the top like a letter V inverted, and as wide apart at the bottom as may be needed for the door of the cellar. The frame is now finished,

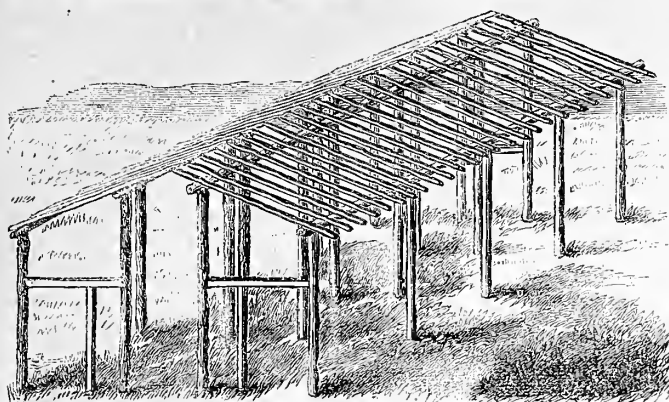

Fig. 2.—FRAME OF STABLE.

and is shown at figure 2. Then a piece of tough low prairie sod is broken, and the furrow slices are chopped with an ax into pieces twice as long as wide. The perfect sods only are laid up outside of the frame into a wall as thick as the length of the pieces of sod; the joints are broken carefully, and all spaces are filled with

appearance. To fit up the inside, rails or boards are fastened to the rows of posts, *b* and *c*, which make an alley-way or feed manger, and a space is left between them so that the animals can put their heads through into the alley to feed.

The cellar is then dug out, steps being dug in the earth for the entrance at *g*. The roof is supported by posts the same as that of the stable, and is covered with hay, then with earth, then again with hay and the earth that was thrown out of the cellar, until it is frost-proof. Shutes may be made at the sides of the cellar by which potatoes or roots may be unloaded directly from the wagon into bins. The entrance, *g*, should be covered with a trap-door. The stable should stand east and west if upon an open prairie without shelter, and hay should be stacked upon the north and south of the west door. The door opening into the feeding alley is at *h*. Sodds cut in the summer or fall are more durable than if cut at other seasons. Figure 3 shows the stable with cellar complete.

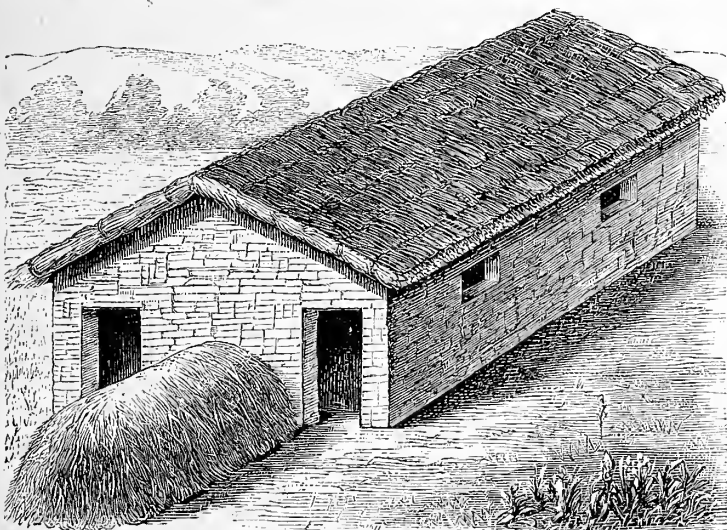

Fig. 3.—STABLE FINISHED.

small pieces of sod. Where windows are wanted, the frames are put in at five feet from the ground, as the wall is built up, and closely sodded around. The walls are built up closely to the roof of rails. A thick coating of prairie hay is laid upon the rails and covered with sods closely fitted together. This again is covered with several loads of coarse prairie hay fastened down with hay ropes or poles. The doors are hung upon wooden hinges, wooden latches are fitted, and all the crevices are tightly packed

over it, leaving a few inches of the first row only to the weather. As the second row is laid it should be beaten down with a wooden paddle to compact it closely. To make a good job there should be at least six inches or more in thickness of hay laid upon the roof.

Draft Irons for Plows.

One of the most important points in plowing is to have the draft exactly right. There are many things which may interfere with the draft of a plow to make it take too much or too little land, or cause it to run into the ground too much or not enough. A proficient plowman may be able to regulate this by altering the traces or otherwise adjusting the harness, but sometimes even this can not be done when the ordinary clevis is used. We give two illustrations of improved draft irons, by the use of which the draft may be regulated with great exactness. Fig. 1 shows one of these irons. It has a horizontal curved bar which is attached to the beam; this is pierced with holes about an inch apart. A vertical draw-plate is also fixed to the beam by means of a pair of straps

and a bolt, as shown in the figure. The draw-plate swings to one side or the other, as may be required to regulate the side draft, and is fixed in the place in which it is to be used by a bolt and nut or a pin and key. The vertical draft is regulated by a series of holes in the draw-plate. Fig. 2 shows a variation of the same principle, in which the position of the bar and draw-plate is reversed—the bar being vertical and the draw-plate horizontal. After having tested both of these we are not able to give a preference to one over the other, and it is a matter of taste or convenience as to which is the more desirable. Probably that shown in figure 1 will be the most frequently chosen.

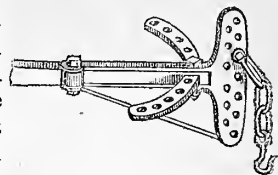

Fig. 1.—DRAFT IRON.

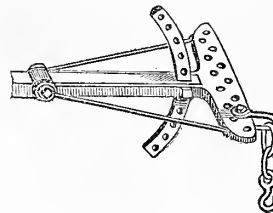

Fig. 2.—DRAFT IRON.

To Build a Chimney.

A correspondent writes us that his chimney "refuses to draw," and the smoke, instead of going up, curls downwards and pours out into the room for some time after a fire is built in the fire-place. The chimney is one of the old-fashioned ones, of large capacity, and that such a chimney should so behave is what surprises our correspondent. But this is just such a chimney as might be expected to do this. The fault is in having a throat of too great capacity. When a fire is made in the fire-place of such a chimney a current of heated air and smoke endeavors to pass upwards. But in its passage it encounters a current of cold air passing downwards to fill the space vacated by the upward current. These counter currents mingle to some extent, and where they mingle curls and eddies are formed. The smoke is entangled in some of these eddies of cold air, and falls with them to the bottom and pours out into the room. If a current of air could be directed towards the fire-place from some part of the room sufficient to overcome this downward current the fault would be cured; but it is seldom that this can be done, and to get relief a radical change needs to be made in the chimney. The back of the fire-place needs to be drawn in, instead of being carried up straight, until the passage for the smoke is contracted to a few inches in width, as shown in the accompanying figure. As soon as the contraction is made the chimney is again widened to its full width. Then the warm current escaping from the throat passes upwards, and the counter current reaching the throat is deflected into the heated stream (as shown by the arrows), which carries it upwards with it, and so prevents it from reaching the fire-place and causing it to "smoke." In building a chimney this should



CHIMNEY.

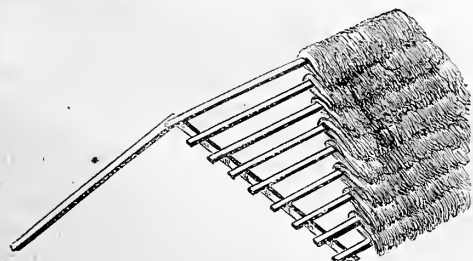

Fig. 4.—THATCHING ROOF.

with sod or hay. If wild cucumber-vines, hops, or other climbing plants are planted around the stable the building will be covered with a mass of verdure which will greatly add to its

be carefully attended to, and of several which we have built in this manner we never had one that smoked at the wrong place.

The Cure of Alkali Lands.

Upon the plains in our new territories on both sides of the Rocky Mountains, there are vast tracts of alkaline soils so much impregnated that they yield nothing but sage brush and grease wood, or are entirely barren. If cultivation is attempted, a white crust soon forms upon the surface, and all cultivated plants die. There are millions of acres of these lands rich in all the elements of plant food, but made worthless by the superabundance of alkali. It has been generally supposed that these lands could never be made productive. The settlers of Utah have been entirely successful in treating these lands, and have done a good work for the nation in demonstrating their great value. We some months ago visited the farm of A. P. Rockwood in the Jordan valley, and saw meadows with a thick heavy sod, yielding three tons of hay to the acre, that were once entirely barren. We also saw upon a neighboring farm wheat fields that would turn fifty bushels to the acre reclaimed by the same process. This matter has attracted the attention of the British Government, as they have large areas of similar lands in India, that they have never been able to make productive. The Desert Agricultural Society have given to the public the best methods of their farmers in reclaiming these alkaline soils. The secret of their success lies in a process of leaching the surface of the soil, more or less prolonged according to the quantity of alkali the soil contains. The field to be treated, of any convenient size, is first surrounded with a ditch about three feet deep, to carry off any water that may be run upon it at the upper edge. It is then laid off into strips about two rods wide by deep furrows running across the slope. The upper side of the furrow is ridged high enough to make a shallow pond covering the whole surface of the strip. The next breadth of the meadow is prepared in the same way, and so on until the whole is finished. Water is then taken from the irrigating ditch and turned into the upper basin, and this communicates with the lower basins until all are flooded. The water is allowed to stand for a few days in these shallow pools, when a frothy scum rises to the surface. It is then drawn off, carrying the scum with it into the outside ditch. As this large ditch is lower than the surface, the water charged with alkali is all the while draining off through the soil. The water is kept running over this land summer and winter, for one or more years, according to its character. In some obstinate cases it is kept in the leach four or five years, before it will bear good crops. In others a single season will subdue it. The best crops for the first season after treatment are found to be castor beans, cotton, summer squash, melons, onions, and lucern. A few inches of sand spread over the surface is thought to have a beneficial influence, facilitating the germination of seed, and preventing the formation of crust. It is agreed by all parties who have reclaimed these soils that they are the most productive lands in the territory, bearing successive years of cropping without any apparent diminution of yield. In some parts of the territory they have succeeded in reclaiming these lands without irrigation, but this is where there

is more rain-fall than in the Jordan valley, and probably where there is less alkali in the soil. A. K. Thurber, of Spanish Fork City, mentions a tract in his vicinity formerly worthless but now used as an inclosed pasture, and producing good feed. He attributes the great improvement in its character "to the increased rain-fall of late years, and partly to the mixing of the grass with the earth through the tramping of cattle, and its becoming thereby decomposed." There is no doubt a large increase in the rain-fall in Utah, and this alone in some cases, has made the land productive. To facilitate the action of the rain the land is plowed up and down the slope that the water may run off freely upon the surface. The land is flowed frequently, and the particles undergo a change as they come in contact with the atmosphere, sun, rain, and frost. There are large tracts of these reclaimed lands in the territory yielding magnificent crops, and fine gardens and orchards loaded with fruit.

Grading Grain in New York.

The past gradual growth of the export trade in grain and its probable continued development in even greater ratio in the future, has necessitated a change in the method of handling the immense quantities yearly arriving at the port of New York, so that it may be transferred to ships with greater economy. Various propositions have been discussed, and vast warehouses and elevators, in which grain may be stored and to which ships may be brought to receive cargoes, have been contemplated, and a bill known as the Gardiner Warehouse bill was introduced into the legislature of New York for the purpose of authorizing their construction. Many serious objections, however, existed to this gigantic plan, both on the score of expense and convenience, and a very simple and inexpensive mode of storage of grain while it is awaiting shipping, has been proposed in its place by the merchants of the Produce Exchange. By this plan the grain will be stored upon the boats in which it arrives, or into which it will be transferred from the cars. The grain will be graded upon its arrival, and receipts given for it which will guarantee to deliver not the identical grain but the same quantity and grade which has been received. The identity of the grain received will, of course, be lost, but by the method of grading proposed, it will be in the same position exactly as so many dollar bills paid into a bank; while the same bills can never be drawn out again, yet an equal number of similar value may be procured on presenting a check. The warehouse receipt will take the place of the check, and will be a negotiable paper which can be sold or bought or transferred by indorsement, calling for so many bushels of grain of such a grade. We can not see that this plan is different in any way from the warehousing system in Chicago or Milwaukee, excepting that the grain is stored in boats, and is therefore much more cheaply stored than in costly elevators, and will be much more cheaply transferred to the ships or steamers than in any other way. Every dollar thus saved, of course, comes finally to the farmer who raises the grain or to the consumer who eats it.

NEED FOR PROTECTION.—The old adage that "shelter is feed," is well exemplified by the following statement of what occurred in

southern Kansas during last winter. The quantity of Texan stock wintered in that district was greater than ever before. Feed was plentiful under ordinary circumstances; but the winter was open with frequent long-continued rains, and the cattle utterly without shelter and chilled to the bone refused to feed or trampled their fodder into the mud and wasted it. Strong three-year-old steers lay down in the mud and never rose again. Out of one herd of 127 head only one was left alive. Many large herds lost 20 per cent, one herd of 140 lost 80, and green Texan stock, less hardy than the acclimated cattle, suffered more than others. The rudest shelter would have saved these cattle. With dry coats they will stand even unusual cold, but a cold rain quickly subdues them. The losses of last winter would have paid for substantial shelters which would last many years, and prairie sods and coarse hay, with a few poles, would cheaply furnish such shelters. We have frequently spoken of the necessity for shelters for cattle on the plains, and the moral is so pointedly enforced in this case, that it is to be hoped it will be heeded even now, while there is ample time to make every preparation for the needs of the coming winter. We have heard of cattle being "in lifts" even in the Eastern states the past spring, and this means simply exposure and starvation. Humanity to our stock is a virtue, and a virtue which is its own reward in a pecuniary sense as well as every other way.

Sheep as a Cleansing Crop.

How to clear our pastures of brush and weeds is a very important question in all our grazing districts. As a matter of fact, upon most dairy farms it requires the utmost vigilance and considerable expense annually in cutting brush to keep them clean. The grazing of cows and young cattle alone will not clean the land from brush and weeds. Patches of briars, whortleberry, sweet fern, hazel-nuts, scrub-oak, or other brush spring up, and spread year by year until the grass is crowded out, and the land is covered with a young growth of forest-trees. In many of the older states there are large tracts of land now covered with timber, that forty years ago were in pasture. In the case of rough, hilly land that can never be plowed, this return to forest is often desirable. But a certain portion of every farm is needed for pasture, and if animals can be substituted for human labor in killing brush and weeds, it is exceedingly desirable to know it. We recently visited two farms lying side by side, with no perceptible difference in the quality or moisture of the soil. The pasture lands were only separated by a stone fence, but something much broader than a fence line had separated the management of the two farmers. The one pasture had been grazed by cattle for a long term of years, and the policy had gone to seed in a magnificent growth of alders, whortleberry brush, young maples, vervain, thistles and golden rod, briars and other brush and weeds. There were patches of grass in perhaps one quarter of the field, where the cows got a scanty living. The other pasture, in addition to its cattle, had the constant tread of a flock of one hundred and sixty sheep, and their hoofs in this case certainly had been gold. Besides all the wool, mutton, and lambs sold from the flock, they had paid for their keep every year in free-

ing the pasture of brush and coarse weeds, and in enriching it with their manure. There was no brush of any considerable size, and very few weeds. And we learned from the proprietor that sheep were the only agents employed in keeping the field clean. They had nibbled the young shoots every year as they started, and what they had not killed outright by this cropping they had kept even with the grass. There was good feed in every part of this pasture, even late in the fall, and the owner of this farm used this contrast between these adjoining pastures as a standing argument in favor of sheep husbandry. It was very much to the point. If it is true, as George Geddes asserts, that sheep in certain proportion to cattle pay their way in a pasture naturally clean, they must pay much better in pastures inclined to produce brush and weeds. We have had occasion to notice the beneficial effects of the grazing of sheep upon another farm that has been under observation several years. They have not only subdued sweet fern, briars, and thistles, but have greatly improved the grasses. The sod is much thicker and heavier, and the white clover has come in where once it made no show at all. In pastures where the brush is already strong, and higher than the sheep can reach, it can not be expected that they will conquer. But if the brush be cut for a season or two, and the sheep turned in sufficient numbers upon the young growth, they will keep it under and eventually destroy it. This is much cheaper than the use of the scythe and plow perpetually.

Sale of Shorthorns.

The popularity of Shorthorn stock is well sustained. Although we can not expect to see the excitement which attended the sale of Mr. Campbell's Duchesses repeated within a generation, yet the recent sale of Mr. Coffin's herd at Muirkirk, near Baltimore, shows that, as a matter of mere business, a sale of excellent stock will attract buyers from all parts of the country, and that good stock retains its full value. The herd consisted of forty-two cows and heifers and twelve bulls, which were descended from the best families of both the Booth and Bates' strains. The average of the sale was \$640 per head. \$1,425 was the highest price paid for a cow, Muirkirk Gwynne, a three-year old roan, which goes to Kentucky, as do also eleven others of the best animals. The sale of part of the Glen Flora herd at Waukegan, Ill., on May 20th, was also well attended. Seventy-eight head were disposed of for \$55,000. The highest price for a cow, \$2,500, was paid by Mrs. Dunlop, of Jacksonville, for Jubilee Gwynne. Eight cows of this favorite family of the Gwynnes brought \$3,300. The average price per cow at this sale was \$900. Mr. C. C. Parks, the owner of the Glen Flora herd, still retains sixty head of the choicest animals. At the sale of General Meredith's stock at Cambridge city, Indiana, on May 22d, fifty head brought \$25,000. The highest price paid for cows was \$2,000, by T. C. Jones, of Delaware, Ohio, for Royal Duchess, and Avery and Murphy, of Detroit, Mich., for Joan of Arc.

On May 21st, the Lyndale herd of Mr. W. S. King, of Minneapolis, Minn., was disposed of. There were fifty-eight cows and heifers and twenty-one bulls, sold for a total amount of \$101,615 for the cows and heifers, and

\$25,375 for the bulls. The average prices were thus \$1,752 and \$1,200 respectively. The highest prices were for a pair of twin heifers, Lady Mary 7th and 8th, \$11,000, and for a bull, 2d Duke of Hillhurst, \$14,000. This last price is the highest ever yet paid for a bull; and thus those who fancied that the prices paid at Mr. Campbell's sale would never again be reached, have proved to be mistaken. Indeed, considering the well-deserved popularity of the best families of Shorthorns, and the high excellence and intrinsic value of this class of stock generally, it is unsafe to predict that present prices may not be far outreached in the future.

HERD-BOOKS.—Of making many herd-books there is no end. For every breed of horned stock we have a herd-book, and the fact that this is necessary only goes to show that stock-breeders are very much like others, herd-books being neither more nor less than a method of guaranteeing the purchaser, to some extent, against imposition. But when herd-books for swine, for sheep, and now for poultry are proposed, it is time to ask for what good purpose are they needed. For cattle, which do not very rapidly increase, and whose identity is easily determined, it is desirable to have the safeguard of a herd-book, provided it be only thoroughly well and honestly managed. But for animals which reproduce so rapidly and the identity of which it is so impossible to preserve as that of pigs, sheep, or fowls, herd-books seem to us not only useless but impracticable and absurd.

Roads and Road-Making.

It has been said that the civilization of a people is measured by the condition of their roads. If we should judge ourselves by this test, at least so far as our wagon roads are concerned, we must admit that we are somewhat behind the general standard of civilization. But the prevalence of railroads has greatly diminished the importance of other roads, and made them but secondary means of communication instead of primary ones, as they formerly were. Nevertheless we can not ignore the fact that the usual bad condition of our country wagon roads is a serious tax upon the agricultural interest. A badly-made road is expensive to keep in repair, and one which costs only \$1,000 a mile to construct at the outset will have cost in the course of ten years a sum which would have paid for an excellent road upon which very few repairs would have been necessary. Again, a bad road, built for \$1,000 a mile, is more costly to use than one on which three or four times as much has been expended in making it, because a farmer who draws loads to market upon the one can only carry a third or a quarter as much as upon the other, and to move this reduced load requires double the time that the larger load would on a good road. There is hardly a question that any community can better afford to build a level, solid, smooth, stone road at a cost of \$6,000 or \$8,000 a mile, and maintain it in good order at a merely nominal annual cost for forty or fifty years, than to build an uneven, rough, soft, earth road at a cost of \$1,000 a mile, and keep it in barely passable condition for the same number of years at the necessary high annual cost. This leaves out of calculation the loss of time, team power, and wear of wagons,

horse-shoes, and harness which is inflicted upon every traveler who uses the road.

All this shows the importance of laying out roads of easy grades, and passing around hills instead of over them, and of making the surface hard, smooth, and durable. Probably one of the best county roads in the country is one now in course of building by the Telford Pavement Company of Orange, N. J. Some time ago we had an opportunity of inspecting this method of road-making, and here describe it, with the machinery used both in preparing the material and finishing the road-bed. The road-bed is first excavated, graded, and properly formed to a depth of fourteen inches from the level of the gutters; this cross section is made to conform in every respect to the cross section of the pavement when finished. It is then thoroughly and repeatedly rolled with the steam roller, all depressions which may appear being carefully filled and rolled before the stone is put on. On the road-bed thus formed and consolidated a bottom course or layer of stones of an average depth of eight inches is set by hand, in the form of a close, firm pavement, and thoroughly rammed or settled in place with sledge-hammers, all irregularities of surface being broken off and the interstices carefully wedged with pieces of stone. An intermediate layer of broken stone, of a size not exceeding three inches in diameter, is then evenly spread thereon, to the depth of four inches, and thoroughly rolled, after which a half an inch of sand is applied and rolled in. The surface layer of broken stone, of a size not exceeding two and a half inches in diameter, is then put on to a depth of four inches, thoroughly rolled, and a half an inch of sand applied and rolled in as before. Care is taken to so spread the stones that the total depth when finished shall be uniformly not less than fourteen inches, and that the grade and cross section of the pavement may be perfect when thoroughly consolidated. A binding composed of clean sharp sand, or of the screenings of the broken stone, is then applied, well saturated with water, and thoroughly and repeatedly rolled with the steam roller until the surface becomes firm, compact, and smooth, when all superfluous binding material is swept off and removed.

The steam roller weighs not less than fifteen gross tons, and is so constructed that its compressive force on the roadway being rolled shall not be less than 450 lbs. per inch run.

The cost of a road thus prepared is \$1.00 per square yard for nine inches in depth of stone, and \$1.50 per square yard for twelve inches in depth. A road five yards wide, of the former description, would thus cost \$8,800 per mile. A road like this would be of such a permanent character as to require very little repair for many years, and could be kept in good order at a very small annual expense. In some parts of the country the citizens have already found it a measure of economy to raise money by bonds to make roads of this character, the annual saving in cost of repairs being sufficient to pay the interest upon and provide a sinking fund for the final payment of the bonds, when the road will practically have cost the township nothing as compared with the former poor roads.

The road material is rock. The best rock is hard trap; the next best is crystalline limestone; but the ordinary "hard-heads" or boulders, so common in many places, when broken, furnish one of the best materials. The soft

limestone common in much of the western country will make an excellent road, but will need more frequent renewal, the cost of which, however, is but a small item compared with that of the foundation. Neither is it necessary

hardest rock to fragments of the required size. The broken rock is then hauled and spread upon the road to the proper depth, when the steam roller compresses it with great force into a solid mass which binds together with great

a grade of one foot in fifteen. An engine weighing eight tons has a compressive force upon the road of 270 lbs. to an inch of bearing surface, and uses 400 lbs. of coal per day. The total cost of working is about \$6 a day,



Fig. 1.—WARING'S ROCK-DRILL.

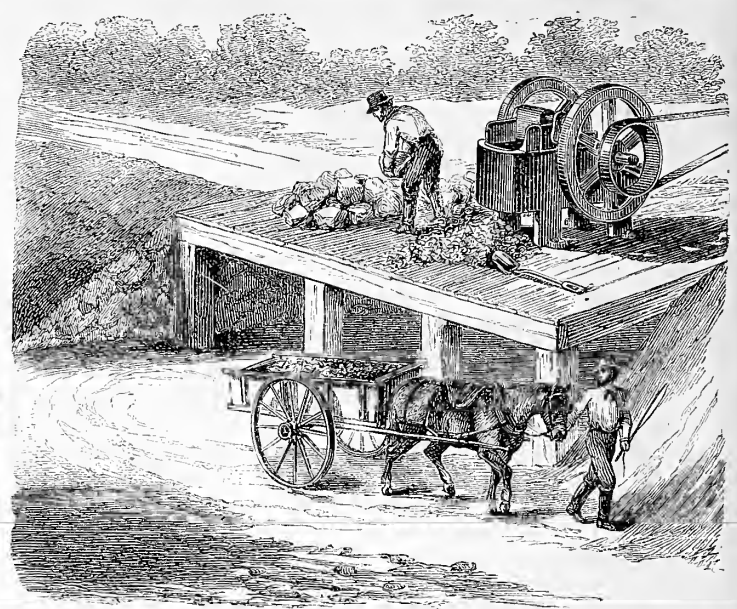

Fig. 2.—STONE-BREAKING MACHINE.

in all cases to be at so great a cost for the preparation of the bed. A very fair road may be made without excavating the foundation, and a large portion of the cost saved. If the rock is to be blasted from a ledge, the compressed air-drill or a percussion steam-drill is used. The drill shown in figure 1 is the Waring com-

compactness. A certain portion of sand or fine stone screenings adds greatly to the binding together of the stone.

The steam roller is shown in figure 3. It is a road locomotive which has a double set of wheels, one for ordinary draft purposes, and one of greater weight and width used only for

and the cost of the engine with a set of four furrow plows for preparing the foundation or for field plowing is about \$4,000. An engine of this weight is twelve-horse actual power, and may be used for threshing or any other purpose to which a locomotive engine is suitable. This general availability renders it of

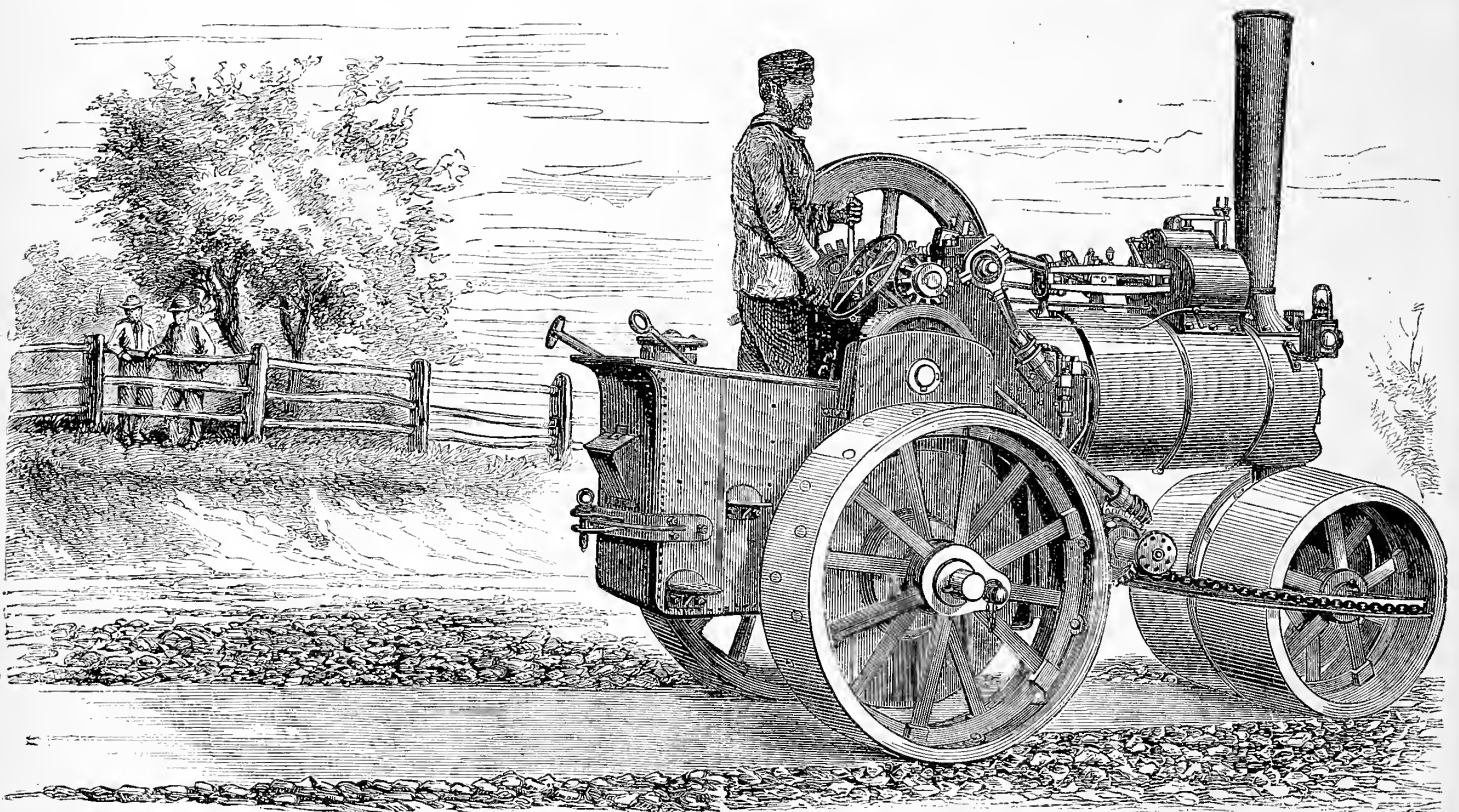

Fig. 3.—AVELING & PORTER'S ROAD LOCOMOTIVE.

pressed air-drill, which is capable of making 1,000 strokes per minute and of boring in any ordinary rock with great rapidity. In the employment of drills of this character a large amount of time and labor is saved. The rock is broken by a Blake stone-crusher, which powerful machine (shown in figure 2) reduces the

rolling and compressing the road. It is made by the Messrs. Aveling & Porter, of Rochester, England, but is imported and sold by their agent in this country, where it is already in somewhat extensive use. One of these engines has drawn eleven two-horse wagons loaded with stone upon an ordinary country road up

such service that its cost is within the means of almost any township in the country or of any agricultural association. Some of our agricultural societies could, by putting these machines in use, help to solve the question of the usefulness of steam cultivation, and also that of how we can have durable roads.

Long Moss—*Tillandsia*.

To the traveler in the Southern States no natural object is likely to be more striking than the Long Moss, which from North Carolina to Texas drapes the trees of all kinds, but is especially abundant upon those which grow in damp situations. This moss is sometimes found only here and there in small tufts, but frequently it is in such quantities upon a tree as to appear to fill all the spaces between its branches, and from the lower limbs it hangs in pendent tufts several feet in length, which as they are swayed by the wind wave with a certain grace. In localities where the moss is very abundant, its dull gray color and general drooping habit produce a very somber effect. As it grows most luxuriantly in situations which from being constantly moist are unhealthy, it is easy to associate it with disease and death, and in some localities it bears the not very cheerful name of "Coffin Fringe." Though popularly called moss, it does not belong to the proper mosses at all, but, strange as it may seem, to the Pineapple Family, the *Bromeliaceae*. Its botanical name is *Tillandsia usneoides*. The genus was named in honor of a Russian professor, Tillands, and its specific name means, resembling *Usnea*, a long drooping lichen which hangs from Northern trees in a similar manner. Including this there are eight species of *Tillandsia* in the United States, this being the only slender pendulous one; some of the others have broad, pineapple-like leaves, two feet or more long, with their bases dilated so as to hold water. All the *Tillandsias* are epiphytes—*i. e.*, they grow upon other plants, mostly upon the branches and trunks of trees, but they are not parasites, as they desire no nutriment from the plant to which they are attached; this merely serves them as a resting-place, and they are nourished entirely by what the air and the rains bring to them. Some of the South American and West Indian species are valued as ornamental hot-house plants, and are usually grown in pots of sphagnum, a condition which approaches nearly to their natural one. Indeed, our Southern species are some of them quite handsome, especially *T. bracteata*, the bright red stems of which bear small purple flowers. The species under consideration, *T. usneoides*, is, as just stated, of a very different habit from the others; its long, branching stems are so slender as to be almost thread-like.

Several years ago we wished, in answer to some questions, to give a figure of this plant. Having herbarium specimens, we supposed that with these and the aid of an engraving of the flower we could easily present an illustration of it; but much to our surprise we discovered that the only engraving of this very common and useful plant was to be found in a work published in Paris in 1823—and not accessible. We then attempted to procure living materials for an engraving, and wrote to several correspondents in the Southern States to send us the plant *in flower*. We received abundant specimens with the remains of seed-pods, which were no doubt mistaken for flowers, but only this spring have we been able to procure the flower. Our correspondent, Dr. H. G. Mangren, of Volusia Co., Fla., sent us flowering specimens, and though the flowers he packed all faded, an abundance of others opened when the plant was placed in the greenhouse, and we are thus enabled to give an engraving of the plant

in flower. We mention these matters to show the difficulties which sometimes attend the illustration of a very common plant.

The slender stems produce leaves at intervals of about three inches, which are narrow, recurved, and from two to three inches long; from the axil of each a branch is produced,

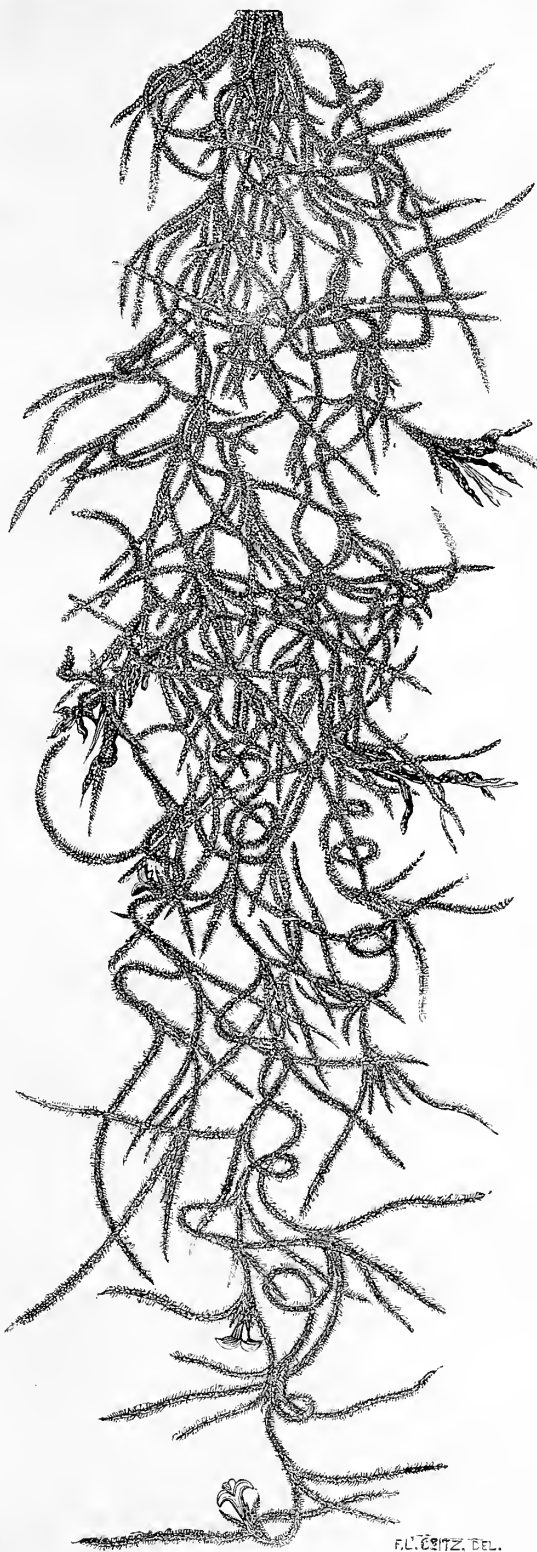

LONG MOSS.—(*Tillandsia usneoides*.)

which may be terminated by a flower or be much prolonged to form a part of the tangled mass of stems of which each plant consists. The plant presents one peculiarity of which we find no mention in any of the descriptions: each internode, or space of the stem between two leaves, in the young stems at least, forms an open graceful spiral of about two turns, which adds much to the beauty of the plant, when its stems are separated and allowed to

grow singly. Both stem and leaves present a uniform gray color, which while the plant is growing has a greenish tinge; an examination with a glass shows the stem and leaves to be of a light apple green, but completely covered with small, almost transparent, overlapping scales, which give the silvery gray appearance.

The epidermis is readily separated from the central portion of the stem, which is tough, and resembles horseshair in size and appearance. The solitary flowers are borne at the ends of the branches; they have a three-parted calyx and a corolla of three petals, which, though not more than a fourth of an inch across, is exceedingly interesting from being of a bright gamboge green color. The pod is about an inch long, and splits up in such a manner that it looks very much like a withered flower; this, together with the small size and unusual color of the proper flower, has no doubt troubled unbotanical observers who have endeavored to furnish us with flowering specimens.

Aside from forming a striking feature in the landscape, the Long Moss is of no little economical importance. The central portion, exceedingly tenacious and elastic, has long been employed as a substitute for hair. The plant is found in Central and South America and the West Indies, and has been put to so many uses by the Spanish Americans that in some localities it is known as "Spanish Moss." The primitive method of procuring the fiber is to place the moss in shallow ponds exposed to the sun to rot the somewhat fleshy outer covering; it is then taken out and allowed to dry, after which a moderate beating removes the outer portion, and the fiber is left in a black, tangled mass, which but for its branching character it would be difficult to distinguish from hair. We learn that since the war several establishments have been erected for the preparation of the moss in a more rapid manner. The moss is placed in large tanks, where it undergoes maceration by heat, and after drying is beaten by machinery; this is said to afford a superior product. By itself it forms an excellent stuffing for mattresses, chairs, and the like, and is probably largely used to mix with hair; it forms a considerable article of commerce, and its domestic uses are numerous. In Texas we have seen it twisted and woven into a coarse matting to serve as a saddle blanket, and have also seen horse-collars woven of the same material. It is said to be capable of forming excellent ropes and cables, and we have recently seen a newspaper announcement of the formation of a company to manufacture these articles from the tough fibres of the Long Moss.

APPLE-TREE BORER.—We have followed this insect with a sharp wire for over thirty years, and if there is any better remedy for the creature after he has begun to throw out his chips, we have not discovered it. With a sharp-pointed knife and a bit of wire a few inches long, it is not a very difficult task to dislodge the enemy. He should be attacked as soon as he makes his appearance. Young apple-trees should be examined at least twice a year. The sooner the borers are destroyed, the smaller the wounds that will be made around the collar of the tree. Generally the worm can be reached with the point of the knife. If this can not be done, follow him with wire. As a preventive, we have found oil-cloth, or

stiff, thick paper to answer a good purpose. Remove the earth an inch or two around the collar, then bind on the cloth or paper with a string. We have seen fine, thrifty young apple-trees, worth five dollars apiece, destroyed for the want of a half hour's attention in the spring.

The European Daisy.

The Daisy is a plant so commonly referred to in English poetry and literature that it seems a great pity that it should be of difficult cultivation in this country. There are many who suppose our common Ox-eye Daisy or White-weed to be the same as the plant so frequently referred to by European writers. Two plants of the same family can hardly be more unlike than the Ox-eye Daisy (*Leucanthemum vulgare*) of our meadows and the European or English Daisy (*Bellis perennis*), which while it often appears as a weed in English lawns, is nevertheless in its cultivated forms a charming flower. In its wild state the proper Daisy has a yellow disk or center surrounded with white or pinkish ray florets, but in cultivation the disk disappears, the florets are all like those of the ray. There are two obstacles to its general cultivation in this country: our summers are too hot and our winters are too cold for it, and it, like the Polyanthus, Auricula, and similar plants, can only be successfully grown by treating it as a frame plant and giving it protection from extremes of temperature. Considerable quantities are sold in our city markets every spring, in pots, and forced into early flower. These are especially attractive to English and other Europeans, who gladly purchase a plant that reminds them of home, but their purchases, if the plants are set in the open ground, can only result in disappointment. The Daisy is readily raised from seed, which will give a portion of double flowers. The seeds should be sown in a slight heat, and the young plants potted off and kept in a shaded frame in summer, and in winter be plunged in coal-ashes in the frame and kept from severe frosts. It is easily multiplied by division of the clumps. One form of the plant, known as the "Hen and Chickens," has the flower-head surrounded by a ring of smaller heads which are produced from just beneath it. Within a few years several choice varieties have been produced, which in England play an important part in the decoration of borders in spring; there is a great variety in the size of the flowers, as well as in their colors, which range from pure white to bright crimson; besides this there are some with the foliage handsomely marked with spots, like the leaves of Aucuba, and are called *Aucubæfolia*, there being both white and red flowered kinds with marked leaves. One of the finest daisies we have ever seen was left at our office in April last by Mr. J. T. Lovett, who is with A. Hance & Sons, nurserymen and florists, Red Bank, N. J. This was received from England as "Queen Victoria," and is truly a queen among daisies. It is a strong-growing plant, and a most abundant bloomer, producing flower-heads an inch and a half across. The florets are of a bright carmine on the outside and white within; a part are completely quilled, or tubular, and others are flat, and the contrast between the two surfaces produces a pleasing variegation. If we can not enjoy the daisies as hardy border plants, there are some, such as the one referred to, eminently worthy of being cultivated for greenhouse decoration.

How to Propagate Roses from Cuttings.

BY W. F. MASSEY, CHESTERTOWN, MD.

[There is no plant that the amateur more desires to propagate than the rose, and there is none with which he more frequently fails. The majority of roses offered for sale by florists are propagated in spring from cuttings taken from potted plants which are started into growth for the purpose. Another method is to take off cuttings of ripened wood in October and set them in a frame where they will be protected from severe cold weather; by spring the majority of the cuttings will be found to be callused, if not rooted. The method given in the following article is not generally known, and will be acceptable to many. The author is of the firm of Massey & Hudson, Chestertown, Md., who make a specialty of furnishing roses at cheap rates. They this spring sent us some specimens of the stock they grow in the manner here described, and we have seen no finer and more healthy young roses from any place.—Ed.]

The best time to commence the propagation of Roses, especially the everblooming sorts, is about the last of August. The best cuttings are taken from plants which have been grown in beds under shaded glass during the summer, but if the weather is moist, and the plants out of doors are in a vigorous state of growth, as good cuttings can be procured from the open border as from plants under glass.

Prepare a bed of clean, coarse sand, not less than four inches deep, either on the benches of a greenhouse or in a cold-frame out of doors. The cuttings will do as well in the one place as the other, but if a greenhouse is available the bed will be more convenient to work at. This sand bed is then to be soaked with water, and never afterward allowed to get dry. For cuttings, select shoots not more than a week or so old. The slender, wiry shoots of the monthly roses which just begin to show a blossom bud are the best. Avoid the rank, pithy young shoots which frequently sprout from the base of the bushes; these will root, but not so readily as the more slender shoots, nor do they make so good plants. Cut off the soft tip of the shoot, and divide the remainder into cuttings of not less than two eyes. The top of the cutting should be cut at least three fourths of an inch above an eye, and the leaf at this eye should remain on; the base of the cutting should be about a half inch below the second or third eye, the leaves from which should be stripped off. If the wood buds in the axils of the leaves on the lower part of the shoot are fully developed, it is an indication that the wood at that point is too ripe to take root easily, and should not be used unless cuttings are very scarce. In short, the cuttings must not be so soft as to present no woody fiber in cutting, neither must the wood be hard; a little experience will soon indicate to a close observer the exact state which is best.

Having your cuttings all prepared and your sand bed ready, take an old knife or a piece of hoop iron and, using a lath or other straight edge as a ruler, cut a line at the end of the bed across the sand, going completely to the bottom. In this line or groove set the cuttings nearly up to the leaf at the top and about half an inch from each other in the row. Turn the leaves of the cuttings all in one direction, so as to be out of the way in setting the next row, and also to present a neat appearance. When the first row is filled, press the sand tightly to-

ward the row, and about three inches from this first make a second row and fill it in with cuttings in the same manner, turning all the leaves toward the first row. Proceed in this way until the bed is filled or your cuttings exhausted, then sprinkle the bed thoroughly with clear water. The glass over the bed must be shaded with a thick coat of whitewash, and the house or frame kept quite close. If in a cold-frame, the sashes may be slipped down an inch or so at the top during the heat of the day. The frames should slope north, and not south as usual. If the bed is in a greenhouse there should not be any ventilation given overhead; a little air from the doors or side ventilators is sufficient. If the thermometer rises during the day to 100° or over, it will not hurt if the bed is kept watered and the house moist and shady. The cuttings will be rooted sufficiently to pot in about four weeks, and the process of propagation may be continued as late as good cuttings can be had from the open ground, provided some means is at hand for heating the bed when the weather grows colder. When rooted, pot off into 2½-inch pots, using decomposed sods and woods-mold in about equal parts with a very small portion of well-rotted manure. Water thoroughly and keep shaded until they start to grow. When well established in the pots, plunge them in a cold-frame or pit for the winter and protect from freezing. In spring plant out where they are intended to flower. If wanted for sale in spring, shift them into three-inch pots in January and place them in a greenhouse where the night temperature does not exceed 50°, and by the last of April most of the everblooming sorts will show flowers and make fine plants for the market.

This method of propagation is more especially applicable to the tender varieties such as Teas, Noisettes, Bengal, and Bourbon, as the wood of these sorts is usually in the proper condition in autumn, but any roses can be rooted in the same way if shoots can be had of the proper age. During the past fall the writer has propagated thousands of Moss roses in this way, which he was enabled to do by the favorable weather which kept the plants in vigorous growth. Moss-rose cuttings should be almost as tender as the green shoot of a scarlet geranium. In this condition we never have any difficulty in rooting them. The above method can be used by almost any one, while the propagation of roses during winter and spring can only be practiced by florists who have houses adapted to the purpose.

About Pickles.

A farmer sees that a jar of pickles sells at the village store for fifty cents; he knows that he can raise the quart of cucumbers it contains for a very few cents, and estimating the cost of vinegar, bottle, and putting up at a liberal figure, he finds that there must be to some one at least thirty cents profit upon each jar that is sold. He thinks here is a chance for a profitable undertaking; he has the land and knows he can raise the cucumbers, which in his eyes is the main thing, and he writes to his agricultural paper to know all about putting up such pickles as are sold in the stores. The fact is that the cucumbers, while they are the principal thing to the consumer, are but a small part of the investment of the pickle-maker. It is probable that if one of our farmer friends who have an idea of pickle-making could have bottles, vinegar, and all other necessary materials

placed on his farm free of cost, he would make a very poor business of it; he might sell a few at the stores where he traded, but he would meet with no general sale. The person who put up the pickles he saw at the store has been for years in building up a reputation, so that his name upon an article sells it at once; then he has his factory at a commercial center from which radiate the channels through which merchandise passes out to the consumer. He has sufficient capital to allow him to carry a whole year's stock, and buildings large enough to contain it, and the sum invested in cucumbers and other vegetables to be pickled is but a small share of the whole. In this as in many other cases, it is not easy for the producer of the raw material to manufacture it for market. While we would encourage every one to do that which will make his farm more productive, we do not think that pickle-making or fruit-canning can as a general thing be made profitable on ordinary farms, on account of the capital and skilled labor required. In fact the production of the raw material, and the preparing of it as a finished product for market, are two distinct kinds of business, either of which requires the whole energies of the person who engages in it. The growing of cucumbers forms a legitimate part of a farmer's or gardener's business, and when he is within easy reach of a factory where he can deliver his cucumbers fresh, or is able to put them up in salt for the market, it is often a profitable one. Any good land will produce a crop of pickles, but the hills must be enriched with fine manure. Mark out the land about five feet each way and at the intersections spade in a shovelful of manure to mix it well with the soil. The seed is usually put in the last week in June or the first week in July. Where small pickles are in demand the Early Cluster will give the best results; if large ones are wanted, the White Spine may be sown. The Long Green Prickly, while it produces a fruit long in proportion to its thickness, is such a poor bearer that growers generally discard it. Indeed those who make a specialty of this crop raise their own seeds and are very particular in the selection of the plants to furnish them. By careful selection for a few years each grower establishes a strain which he thinks better than any other and of which he is very choice. An abundance of seed is sown in each hill to guard against accidents; although insects do not so trouble the young to the extent that they do earlier, it is well to have air-slaked lime at hand to check them in case they are destructive. The ground is to be kept clean by the use of the cultivator and hoe, and when the plants show two or three rough leaves, thin them to leave three or four of the strongest to the hill. Some growers sow round turnips at the last hoeing and thus get a double crop from the land. In case the cucumbers are supplied to a factory there should be an understanding beforehand as to sizes; the usual size is four inches, but for certain purposes they are required smaller than this. Much of the success of the crop depends upon the picking; if a vine is allowed to ripen the first fruit it sets, it will produce but little after that. There should be force enough to go over the vines every other day, and the pickers should be taught to pick not only the fruit of the required size, but everything that has grown beyond that, in order to keep the plants up to their full productiveness. The cucumbers must always be cut and never pulled, not only for the safety of the vines, but because those with stems are more salable. Picking is usually

done by women and children, who are paid by the thousand a price which varies with the locality from twenty-five to forty cents. The pickers should be careful not to tread upon the vines. The delivery at the factory may be made at such times as may be agreed upon, as if not in such large masses as to heat the cucumbers will be in good condition for several days. Those who send their pickles to market salted follow different methods. One of our friends who was formerly largely engaged during the war in supplying the southwestern markets put up his cucumbers in the following manner. New barrels were used, and one head being removed, the barrel was filled as full as possible by shaking, about half a peck of salt added and the head put in place. The barrels were then filled quite full of water through the bung-hole, and then bunged up tightly. He stated that as they were sold by the barrel and not by count, it was a profitable business for him. It is probable that in tightly closed barrels the pickles would keep for some months in this weak brine; at that time the article met with a ready sale, and our friend never heard any complaint of their spoiling. Mr. Waldo F. Brown, a well-known Ohio seed-grower, in his "Farm Quarterly" for April gives his method of salting cucumbers as follows: "Cover the bottom of your barrel with salt, then pour in a bushel of pickles, then sprinkle three or four quarts of salt, and so on till the barrel is full. In twenty-four hours you will find the barrel only two thirds full, and the brine at the top of the pickles; then fill again, and perhaps a third time, and when full put on a loose-fitting cover and a weight to keep it under brine, and nothing more is necessary except to see that the brine does not settle so as to leave them bare, in which case make strong brine and refill. Many make brine and pour over them; but by my plan nearly one third more pickles can be put in the same space, and I think the pickles are better for drawing the juice out of them, and if salt enough is used they will keep indefinitely. I have kept them over the second summer in fine condition. A forty-gallon barrel will hold about three thousand pickles, if salted as I direct, and with a little experience a man can count and pack four thousand an hour."

Ferns and Fern Collecting.

Taken as a whole, few plants present a greater variety of graceful outlines than do our native ferns. Those who go from cities for their summer vacation are quite sure to be attracted by the ferns, and as they have seen other ferns cultivated in cases and in greenhouses, they set to work to gather the roots of these to take home for the decoration of their rooms during winter. Ladies, and sometimes gentlemen too, make excursions to the hills and valleys in search of these plants; the roots are carefully placed in boxes and watered and shaded until the time for the return, and on the journey home the parcels are taken by the collector's own hand, as something too precious to be risked with the baggage. At length the plants find their place in the fernery, and are watched with much interest. They perhaps do not look very well, but that may be on account of the journey. As cool weather comes on the ferns look worse, and are given more heat. A still worse condition suggests that they should be kept cooler, or have more air, or more or less light; but with all the changes they go

backward, and by Christmas the probabilities are that not a green frond is to be seen. This want of success is ascribed to improper soil, too much or too little water, or to any cause but the right one—a want of knowledge of the plants themselves. The fact is that the great majority of our ferns are deciduous, and when taken home at the end of summer no treatment whatever will make them flourish; they have completed their career, and must have rest until the next season. These deciduous ferns, graceful and delicate as they are, will not answer for house-culture; we have a few ever-green ones, readily distinguished by the firmness and persistence of their fronds, which will do admirably; but with the exception of these, if we would fill up a fernery, we must depend upon the exotic species furnished by the florists. Still we would not discourage the collecting of native ferns, for much enjoyment may be had from their cultivation, only it must be for the most part out-doors rather than in the house. There are but few city yards that do not furnish a shady corner which will allow of a small fernery, and some stones should be arranged to form a little rock-work on which many kinds will grow that would not flourish in the border. Some ferns seem to need the protection the stones afford to their roots. Upon such a small scale no very picturesque rock-work can be achieved; the best that can be done is to imitate some rocky hill-side with crevices between the rocks which are filled with earth, which extends down to and is in connection with the soil of the border. This precaution must be observed in making a rock-work of any kind, large or small, for ferns or any other plants, for if the earth is in mere pockets it will soon dry out, and as no supply of moisture can come up from below the plants will in a dry time be sure to perish. To those fond of ferns there is every encouragement for them to attempt their cultivation in the manner here stated, and we have seen several ferneries in city yards which possessed much interest, the plants having been accumulated during successive summer excursions. In collecting ferns, it would be better to remove them in early spring, just as they are starting into vegetation. But while this is practicable to those who live in the country, those who live in cities must take them just as they are in the height of their growth or not at all. In this case, the best thing to do, after having secured a good clump of roots, is to cut away all the fronds, provided the plant is one of the large kind. If considerable time must elapse between the time of gathering the plants and that of taking them home, it will be best to set them closely together in a box in which some woods-earth has been placed. Put the plants in a shady place, and sprinkle as often as may be needed to prevent them from drying out, yet they should not be too wet at the roots. In setting the ferns out, as near an approach as possible should be made to the natural localities of the plants. Those found upon rocks should have a place on the rock-work; those that were collected along the edges of thickets and by roadsides will make themselves at home in the border; and the "Ostrich Fern," which grows in rich, moist soils, and the "Flowering Ferns," which come from the margins of swamps, may have a place to which water can be conducted to keep up the proper moisture. The great trouble the town cultivator will encounter will be the soil. Very often that in the yard is of the poorest kind, and mixed with builder's rubbish. For some species it will be absolutely

necessary to have soil that is light, and which contains a large share of vegetable matter—such as is known as woods-earth or leaf-mold. It sometimes happens that a florist will furnish a supply of soil of this kind for a moderate sum, or arrangement can be made with some

of leaves besides. The stem is terminated by usually two umbels of flowers, which have the structure peculiar to the genus. But few plants present such a striking departure from the ordinary form of the flower as do those of the Milkweeds. Wonderfully curious is the ar-

are derived from Latin and Greek, could be perplexed as every druggist is almost daily by the indefiniteness of common names, they would gladly adopt the definite botanical ones. To distinguish the Yellow-root in question from the others Dr. Gray very properly gave it



G. J. S. dec.

FOUR-LEAVED MILKWEED.—(*Asclepias quadrifolia*.)



SHRUB YELLOW-ROOT.—(*Zanthorhiza apifolia*.)

market gardener to bring in a barrel of the desired material. One who is really in earnest can procure it without great difficulty. We would advise those who collect ferns by all means to learn their name. We have seen a large collection, the result of several years' labor by a lady, who did not know the name of a single one of her ferns, and we could not help thinking how much more she would have enjoyed her pets could she call them by name. In Gray's Manual the ferns of the Northern States are carefully described by Prof. D. C. Eaton, and as one specimen of each genus is so illustrated by engravings that its characteristic parts are distinctly shown, almost any intelligent person can with a little study make out the names of the species he finds.

The Four-leaved Milkweed. (*Asclepias quadrifolia*.)

One or more species of Milkweed is to be found in almost every locality, but the commoner ones which grow along roadsides and in fence-rows have generally a coarse, weedy look. Not so the little four-leaved species of the woods, which is as delicate as the others are coarse. This has a slender stem, one to two feet high, upon which are one or two whorls of four leaves together, and one or two pairs

of the stamens, from which the pollen can only be removed by the help of insects, and singularly beautiful is the crown of cups attached to the stamens, each cup or hood looking like a minute, tinted shell, within which is a slender curved horn; this crown is often the most conspicuous part of the flower. In the present species the hoods are nearly white, delicately tinted with purple at the base. The flower appears in June, and has a most pleasing fragrance. We do not remember to have seen the Four-leaved Milkweed in cultivation; but it is worthy of trial by growers of native plants.

The Shrub Yellow-root.

It is the misfortune of common names as applied to plants that they are very apt to be used loosely. Sometimes the same name is given to widely different plants, and again a plant will have several common names, and the greatest confusion prevails among the common names of our native plants. There are five kinds of "Rattlesnake Root," three things called Checkerberry, while the plants known as "Snake-root" number a dozen or more, hence it should not surprise us to find three or four distinct plants called in different localities "Yellow-root." If those persons who hold in contempt botanical names of plants simply because they

the name of Shrub Yellow-root, and as the others bearing this name are herbs this simplifies matters greatly. The botanical name, *Zanthorhiza*, is the rendering of Yellow-root into Greek, and its specific name, *apifolia*, means parsley-leaved, as the foliage is cut up something after the style of that of "single" parsley. It belongs to the Ranunculaceae Family, and is interesting as being one of the few members of that large and important family that are shrubs. The plant has long, deep, yellow roots, from which arise several stems, sometimes as high as three feet, but more commonly from one to two. The stems have large terminal buds, from which in spring appear the many-divided leaves and the drooping racemes of small, brownish purple flowers. The general habit of the plant is given in the engraving. The plant is found in Western New York, Pennsylvania, and southward along the mountains. Both root and stem have a very yellow and bitter bark, which was found in use by the aborigines as a dye, which takes readily upon wool and silk. Some years ago it attracted attention as a medicinal plant, but its properties are only those of a simple bitter, and it is not in this respect superior to other and more common tonics or vegetable bitters, which are much alike in their effects. The coloring matter is similar to that of the barberry.

THE HOUSEHOLD.

(For other Household Items, see "Basket" pages).

A Clothes-Line Reel.

An Illinois correspondent sends us a sketch of a contrivance for taking in a clothes-line, which he has made, and, finding it to work satisfactorily, he wishes to give it to the readers of the *Agriculturist*. He justly remarks that it is a great deal of trouble to put up and take down an ordinary clothes-line, and it is often left out and exposed to the weather and soon becomes rotten. We regret that his description is not quite so full as it might be, but, as we understand it, it affords a hint to those husbands who like to make things handy for the "women folks," and give his sketches and description. In the first place, he has an upright box, to serve as a post, built of boards; this is shown at *a* in both engravings, figure 1 being a front view

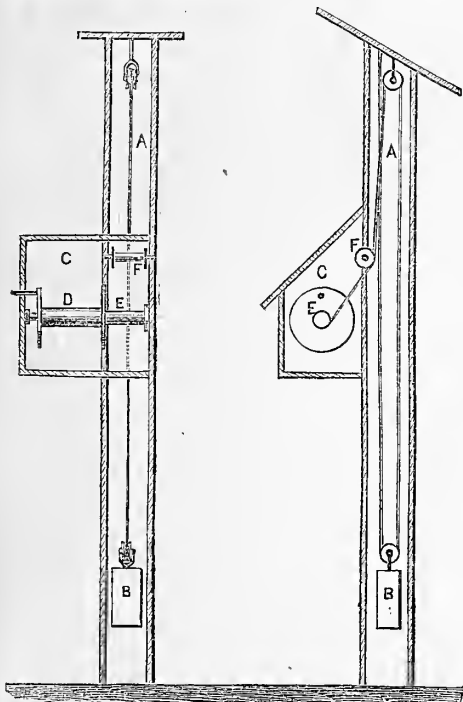

Fig. 1.—FRONT. REEL. Fig. 2.—SIDE.

and figure 2 a side view in section. This box, *a*, is made large enough for the weight, *b*, to move up and down freely inside of it. Attached to this upright box, at the proper height, is a box, *c*, to contain the reel for the line. The reel is double; it has a large shaft, *d*, upon which the line is wound, and a smaller shaft, *e*, for the cord of the weight. This box is so attached to the upright one that the small shaft, *e*, is opposite to it. The weight has a pulley attached to it; the cord from the weight is fastened to the top of the upright box, goes through the pulley on the weight, over a pulley at the top, and down to the shaft, *e*, of the wheel. When this cord enters the box there is a guide pulley or roller, *f*, to make it run smoothly. When the line is put upon the reel the weight is first wound up by revolving the reel, which will wind the weight cord up upon *e*. The line being made fast to the shaft, *d*, the weight is allowed to run down, which will reel up the line upon *d*. There must be an opening in the box, *c*, the length of the shaft, *d*, in order to allow the line to run freely. When the clothes-line is pulled out, of course the weight will be wound up, and when it is to be taken in the descent of the weight will cause the line to be reeled upon its shaft and be properly housed. We give this merely as a suggestion, regretting that our correspondent did not give exact measurement, size of weight, etc., all of which are necessary in explaining such a contrivance.

French Cream-Cake.—Mrs. E. G. B.—
Sugar, 1 tea-cupful; flour, 2 tea-cupfuls; milk,

$\frac{1}{2}$ tea-cupful; eggs, 3; baking-powder, 1 tea-spoonful. Bake like jelly-cake, but have the layers thicker. When done, split open with a sharp knife and place one above another, having the crust down, with mock-cream between each layer made thus: One pint boiling milk, beat well, and stir in 2 eggs, 1 cup of sugar, 2 table-spoonfuls of corn-starch, and lastly add $\frac{1}{2}$ tea-cupful of butter. This cake is better two or three days old. It makes a very nice dessert.

The Atrocity of Feather Beds.

BY A COUNTRY PARSON.

The cackling of the goose is said to have saved Rome. The feathers of the same bird are dealing death to America. We are reminded of this as the summer approaches and the hospitality of rural friends occasionally introduces us to the "feather bed" which has come down an heirloom in the family for five generations. It is a capacious bag, holding some thirty to forty pounds of good, honest goose feathers, plucked a hundred years ago, and held in high esteem by succeeding generations until it has come into the possession of the present incumbent of the old homestead. Underneath this feather bed is the straw bed, filled annually with clean, sweet oat straw. This relieves the pressure upon the bed cords, which are annually tightened at the spring house-cleaning with the old-fashioned winch and pin until the tense cord makes music to the stroke of the hand. This feather bed was a tolerable institution in the days of log houses, with the free ventilation of a big fireplace and rifts in the roof through which the wind whistled and the snow drifted in every winter storm. But now, with tight houses and stoves that heat everything from cellar to garret, the case is altered. No amount of airing and sunlight will permanently redeem the bed from the odor of old feathers, which is anything but agreeable, and the more atrocious effete animal matter that has escaped from the sleepers that have sought repose here for generations past. Think now of John Giles coming in from his day's work in the field where he has been following the plow or driving the mower or reaper, his body all day long in a vapor bath, to repeat the process in the night watches as he stretches his weary limbs upon this unpatented perspirator. Here he tries to sleep, but wakes often from fitful dreams, and tosses as if a fever were raging in his veins. Is it any wonder that he rises from unrefreshing sleep with the early dawn, that he grows lean and cadaverous, and becomes cross and dyspeptic? The poor wife who shares his couch has possibly, in addition to his discomfords, the care of a nursing child. Is it any wonder that she comes to the morning more dead than alive? Is it any wonder that so large a per cent of the inmates of our lunatic asylums come from our farms? The old proverb that "the rest of the laboring man is sweet" needs to be received with several grains of allowance. There is not much sweetness or refreshment on this pile of feathers in the sweltering summer nights. It is surprising to see how long it takes modern improvements to invade the agricultural districts, even with the help of railroads and newspapers. Hair mattresses and spring beds are unknown luxuries in many of these districts where the civilization is at least two hundred years old. "The age of home-spun," supposed by some of our brilliant writers to have departed fifty years ago, is still continued in almost unbroken force. Something cool and soft to sleep on and under, is still a desideratum in most farm-houses. The apology for feather beds and cotton-quilted comfortables is not poverty, but convenience of manufacture. The feathers are a home product, and a tea-drinking makes the quilts and comfortables. Yet John Giles owns his farm, is out of debt, has a good bank account, owns railroad stock, and could have mattresses, fine linen, and blankets if he understood their comfort and economy. Where are our advertisers of good beds and bedding?

Home Topics.

BY FAITH ROCHESTER.

THE CONTENTS OF CHILDREN'S DINNER BASKETS.—I think I will tell a little true story, to begin with—a bit of my own early experience.

I was rather a delicate child, subject to sick headaches and to frequent fits of childish sickness—in the summer fevers, and in winter inflammation of the lungs, cold in the head, *et al.* I got the idea when quite young that I was not expected to make a very healthy woman, and that it would not be strange if I should grow up to be a chronic invalid. It did not occur to me—nor to any one else, so far as I am aware—that this would depend chiefly upon my habits of living during my early years. Though I became a church member at thirteen, I had not the least awakening of conscience in regard to physical sins (or unhealthy habits of eating, dressing, exercise, etc.) until more than five years later, and since then I seem to have been learning only slowly, with pain and difficulty.

When I was twelve years old I was a pupil at a select school more than half a mile from home, and carried my dinner in a small tin pail. I was allowed to put this up for myself, without any supervision from others. A little white "milk emptyings," bread, well spread with butter, went in for decency's sake; all the rest was pie, cake, and pickles. The cake and pickles were my chief dependence.

I used to feel secretly sure that I should soon die of heart disease! My little five-year-old Dot knows more of physiology and hygiene to-day than I did then, though I was getting on well with my algebra and grammar and history, and had just taken a prize for the best composition. I thought it was my heart that pained me so under my ribs after I had eaten the cake and pickles. One afternoon I had to go out of school crying with the pain, and the teacher's wife allowed me to lie on her bed until school was over. Then, instead of walking home, I went to stay all night with my seat-mate, who lived nearer the school. Her mother said it was dyspepsia that troubled me, and that she had it herself. I had heard the name before, and felt rather flattered at having such a respectable disease, and drank the hot tea she prescribed and prepared with an unusual feeling of being in the fashion.

Not long after I took my dinner with me and went home with my seat-mate at noon. I sat nibbling my lunch in the kitchen, where Anna's eldest sister, a young married woman home on a visit, was ironing. I always liked her. She looked into my pail, saying merrily: "I wonder what you carry for your dinner."

"I don't wonder that you have a pain in your side so much!" she exclaimed. "Don't you know that it is the pickles?"

I explained that I had dyspepsia, but she laughed, and told me that I always would have, and worse and worse, as long as I ate such lunches. She counseled me kindly to make the bulk of my dinner of bread and butter or other plain fare. This advice was acted upon in some degree, and I soon found such a connection between pickles and sick headaches and dyspeptic pains, and later between mince-pie and rich cake and the same aches and pains that prudence led me to avoid them. It was not conscience yet.

This experience, like others of the same stripe, has enabled me to realize better the wisdom of the good God in giving us pain and sickness and death as results of disobedience to physical laws. It seems strange that individuals learn the wisdom of obedience so slowly; and very strange that the human race parts with its stupidity in this respect so tardily. Yet all this may not seem slow or strange to us millions of years hence, but only a beautiful part of our Maker's great plan for our full and perfect creation. He might have created us with only instinct, like the brutes, but he gave us reason and freedom to work out our own salvation, physical as well as spiritual.

The dinners of the school children tell steadily upon their growth and welfare and future useful-

ness in the world. Like grown-up people, they use up daily, or waste by excreise of all sorts, by mere bodily combustion too in keeping the body warm with blood, a large portion of the nourishment they get from food. This daily wastage must be made good. Children have not only to repair the daily waste, but to go on building up new bone, new muscle, new brain, as they grow from day to day. Their food should contain nourishment for all parts of the system, and they should have plenty, but they should be accustomed to such plain fare that they can readily stop eating when their hunger is satisfied, and not go on nibbling merely to gratify the palate, thus forming habits of gluttony.

Cake and pastry have but little, and pickles have scarcely a particle of nourishment in them, and they almost invariably do the system positive harm, in greater or less degree, when taken into the stomach. The harm may be so little and the overcoming influences so strong, in the way of out-door exercise and other healthy conditions, that no evil result may be apparent; but all our diseases are caused by violations of hygiene in some respect. We are not always personally responsible for these violations, since our sanitary conditions are not always within our own control, never indeed entirely so; but where we can help ourselves we ought clearly to do so.

LARGE AND SMALL WASHINGS.—There is more than one way to "save washing." There is a right way and a wrong way, and each of these ways includes many details. Of course, I am writing for people of moderate means. Some housekeeping is done "regardless of expense," and regardless of everything but the personal wishes or whims of its directors. "Household" articles on domestic economy are not read or desired in such establishments. But we who have to look after the small arts of living comfortably and healthfully, and at the same time with true economy, must give earnest thought to all departments of our housekeeping.

I know a woman who always used calico night-gowns for herself and children because they would not show dirt like white ones, and could be worn a longer time without washing. But the colored gowns were as much soiled as white ones would have been. White garments can be more thoroughly cleansed, by strong suds, washing fluid, boiling, and bright sunshine, than can colored ones; so I think it a mistake to use colored night-gowns with an idea of saving washing in that way.

This does not exactly apply to the use of gingham or hickory shirts by farmers. A man who works in his shirt sleeves is likely to soil the outside of the garment so very soon that he does well, if he wishes to keep a decent appearance during the days while he must wear the same shirt, to have it made of some material that does not show spots so easily as white cotton, but of fast colors that will bear boiling.

Nor do my remarks about night-gowns apply to children's dresses and aprons. The darlings look "sweet" in white frocks, but I know so much more than I once did about the cost of those dainty garments that my admiration is by no means unmingled with distrust. The first cost may be trifling—no more cents per yard than a good gingham or delaine perhaps. But when the little roly-poly is dressed in its spotless gown and turned loose to play—Oh! But you don't turn it loose to play with white dresses on! No, and that is just the pity of it. There is where you are paying altogether too dear for your whistle. You may spend money in vain for medicines in the effort to buy for a pale and puny child the rosy cheeks and bright spirits and cheerful voice and promise of long life which you have sacrificed to its white dresses in the effort to keep them clean.

A mother may resolve that she will eat her cake and have it too—that she will keep her child in clean white dresses and not restrict his healthy rough-and-tumble exercise out of doors and on the floor. Think it over well, loving mother. How many dozen little white garments can you afford to make on your sewing machine each season? How many can you wash and iron weekly? What hours

of reading will you give in exchange for these labors of love—the sewing and the laundry work? Can you keep your child in spotless robes and yourself in the cheerful spirits that go along with unstrained nerves and a body not overworked?

Our ideas of beauty have their foundation in some perception of spiritual truth, however dim or poorly conceived. Pure and spotless robes are beautiful, and no one dreams of a heaven without them. I too long for them, and gladly believe that when the kingdom comes on earth good gowns and white robes will belong to everybody's wardrobe. But at present I would not take as a gift the wonderful white gown which my neighbor regards as a great triumph of art. It is so fearfully and wonderfully made, with its ruffles and tucks and puffs and skirt over skirt that no one but its owner can be trusted to iron it. This task takes her just one whole day, she says; and the complicated garment can be worn only a few times before it has to have a fresh washing and ironing.

Neither do I envy the hired girls their ruffled white skirts. Annie would tell me at eleven o'clock that the ironing was all done but a few pieces, and in the middle of the afternoon the kitchen fire would still be raging, while Annie's red face was bowed over the ironing-board, where her own puffs and ruffles on her white skirts were being smoothed. Plain hems for me! And white skirts only with very light colored dresses! And very light dresses only for the leisure hours, and not then if they make me fear to have the children run in from play to hug and kiss me.

Give us plenty of undergarments—separate ones for the day and for the night, so that these may be changed and cleansed as often as once a week at least. But there is a great saving in the labors of the laundry if most outer garments be made of colors and materials which can be worn a long time without showing slight spots or stains, but which can be brushed and aired in the sunshine, and sponged in the places most exposed to soiling.

Colored table-cloths save a good deal of labor, and if large oil-cloth mats or japanned paper trays be slipped under the children's plates the cloths will look clean enough to use a long time, especially if carefully folded in the same creases each time. Folded paper under the children's plates will serve in an emergency. The use of table bibs will save the children's aprons a great deal, and if these are of rubber they need not go into the wash.

What Shall we Have for Breakfast?

BY MISS J. J. O., WOODBOURNE, SULLIVAN CO., N. Y.

Being a farmer's daughter, acquainted both by observation and experience with many needs of farmers and their families, I venture sending a few hints. I esteem no one thing more essential to the success of farmers than that of having breakfast well and promptly prepared, so that they may be able to avail themselves of the early, cool morning for their own work and that of their teams. By proper forethought in making allowance for the next breakfast when cooking the dinner, the accompanying lists can be prepared by any active housekeeper in half an hour. Of course, if potatoes and meats are to be cooked, they must be made ready over-night, coffee ground, etc., to spare the vexation of uncomfortable haste in arranging the breakfast. Coffee is supposed to be served at each meal, that being our usual breakfast beverage, although chocolate, tea, or water may be substituted if desired. The kinds of meat may be varied with the season, to include fowls, fresh fish, veal, mutton, or whatever is procurable or desirable; and similar variations may be made in the fruits. It is sometimes a grateful change in midsummer to leave out meats altogether, and add more fruit, either raw or cooked. Potatoes are mentioned in the lists because it is taken for granted that every farmer has them; but those who relish other vegetables, and give them place in the garden (as every farmer should do), will often exchange them for or supple-

ment them with some of the many other healthful vegetables. No breadstuffs appear in the lists, as it is assumed that bread, buckwheat, graham, or Indian meal cakes will be served each morning according to season or preference.

It has always seemed to me that none have better opportunities for an abundance of good food than farmers, providing their wives and daughters appreciate their position as they should, and will give to the preparation of the meals the amount of thought and care that good cooking requires. I fancy that I hear some hurried, overworked housekeeper saying: "Oh! do not speak of putting out any more work or thought on cooking than we now do." Far be it from me to add to the burdens of the already over-tasked American farmer's household; but permit me to whisper a doubt of our work being always just as well systematized as it might be, and just as much pruned of extra duties. I do not purpose to carry this subject out, as it could easily be, to the extent of an entire volume or more; but I must say that it does not appear to me necessary for even independent, middle-class farmers and their families to seek the adoption of furniture, equipage, and dress indulged in by people of more wealth though less independence than farmers; every mere luxury bringing with it added care. Ah, tired house-mother! Leave the ruffles off the children's clothing, put aside the extra stitches and the extra rubs; prepare a simple, healthful, early breakfast (for starting right in the morning is a good foundation for going through the day right), and let every member of the household have a pleasant memory of the dear old farm, its quiet reunions around the breakfast-table, and a thousand other possible reminiscences of peace and beauty to take with them not only through the toils of present days, but through other years, when they may too truly become only memories to its scattered flock.

BREAKFAST LISTS.—The articles in parentheses refer to different seasons:

SUNDAY.—Baked potatoes; roast beef from previous dinner, set in the oven until hot; stewed apples (pie-plant); rice pudding.

MONDAY.—Potatoes, from previous dinner, cut in slices and heated or warmed over by dropping in hot fat, like crullers; roast pork, cold; cucumber pickles (cut cabbage); raspberries, fresh or canned.

TUESDAY.—Boiled potatoes; salt mackerel; chopped tomato pickle (lettuce); pie, apple (pie-plant or cherry).

WEDNESDAY.—Baked potatoes; broiled beef; tomatoes, canned or fresh; stewed apples (strawberries, cherries, etc.).

THURSDAY.—Codfish, *Agriculturist's* mode of cooking; boiled potatoes; cucumber pickles (martynias, etc.); canned plums (baked pears).

FRIDAY.—Broiled ham and poached eggs; apples, stewed or baked; rice pudding.

SATURDAY.—Potatoes, warmed over by slicing in just water enough to keep from burning, to which add butter and seasoning; broiled steak; chopped tomato pickle; cherries, canned or fresh (blackberries, grapes, etc.).

Pudding Sauce.—Mrs. T. H. L. says: "For the benefit of those who do not have milk in plenty, the pudding sauce mentioned in March last can be made very nice by taking the same quantities of sugar and butter, adding water instead of milk, letting it all boil together, and when boiling pour slowly on a well-beaten egg, not putting on the stove again; when nicely thickened by stirring pour into a dish on wine and nutmeg. I use this recipe often."

Lemon Custard.—By Mississippi.—Take four eggs, beat them well; add six table-spoonfuls of sugar, three of butter, half a tea-cupful of rich cream, and juice of two lemons. Beat all the ingredients well together, and pour on crusts and bake. This quantity will make three ordinary-sized custards.

BOYS & GIRLS' COLUMNS.

The Key of the Bastile.

It is likely that every boy and girl old enough to read knows that Mount Vernon is the name of the estate where Washington formerly lived; it was here that he died and was buried. This place, which is upon the Potomac River, a few miles below Washington, is visited by many persons who wish to see the place where the great general and our first President lived, and the spot where he is buried. The house is kept in very much the same condition that it was in Washington's lifetime, and

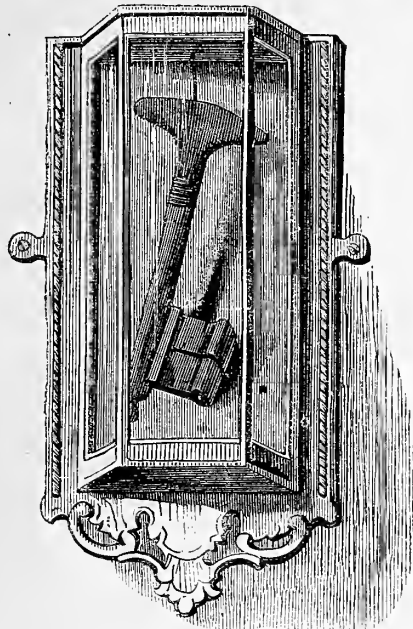

KEY OF THE BASTILE.

the rooms he occupied and the furniture he used are shown to visitors. Among the objects shown is a large key in a glass case, which was sent by Lafayette to Washington—the key of the Bastille. How many of you know what the Bastille is, or rather was? In French it is spelled with two l's, and is the general name for a fortress, but was especially applied to a large fortress in Paris, which was begun as long ago as 1639, and afterwards much enlarged. It was an immense stone building, with towers and a great ditch running all around it, and had numerous cells in the towers, as well as horrible dungeons below ground. This place was for a long time used for the keeping of state prisoners. Princes and others who were supposed to be dangerous to the government were put away here where they could do no mischief. After a while it became a common jail, and great numbers of persons suspected of being opposed to the rulers were confined here. When you read the history of France you will find that the Bastille plays an important part, and that many distinguished persons were imprisoned here, and went from it to be executed for their political belief. There is no sadder page in all history than that of which the Bastille is the center, and perhaps you will sometime read all about it, and learn how the passions and prejudices of people led them to do wicked deeds. For a long time the very name of the Bastille was a terror. During one of the French revolutions, in July, 1789, the people destroyed the famous prison; the guards made but a feeble defence, and the people rushed in, liberated the prisoners, some of whom had been there many years, and one had been confined there since he was eleven years old. The people toppled the towers down into the ditch and underground dungeons, and the whole fortress was completely destroyed. Upon the place where this famous prison formerly stood there is now a monument erected to the memory of the patriots who fell at that time, which is called the Column of July. Lafayette, who was as you know a great friend of Washington, and who was always a patriot, sent to him the key of the terrible prison, as a memento of the triumph of the people over their wicked rulers, and the key can be seen by all who visit Mount Vernon.

Mr. Crandall's Acrobats.

Mr. Crandall has probably done more to amuse young people than any other living man. Some of you who are old enough to read, and doubt whether you are to be still classed among the boys and girls, but think you are almost young men and women, can remember when his building-blocks first came. What a treasure those build-

ing-blocks were, for the things that can be made of them are numberless, and then, unlike all other blocks, the houses and other structures made of them hold together. These blocks have gone all over the country and to far-off countries; for children in Australia and South America are just like other children in wanting to be amused, and fathers and mothers everywhere wish to amuse the children, and it would surprise you to know how many far-off places have sent for the blocks. The loads upon loads that have been sent to different parts of this country, if you could see them altogether, would make a tremendous pile. But Mr. Crandall was not satisfied with his success with the blocks, and away up in his home in the mountains he has been contriving other things to amuse children; he has sent out blocks of various kinds, but at last he has hit upon something new—his Acrobats. Hurrah for the Acrobats! for they are just the funniest things ever made. But stop. What is an acrobat? That question would puzzle more than one old person, and the children might as well know that it comes from a long Greek word meaning to walk on tiptoe; it was first applied by the French to rope-dancers, and has since been used for persons who perform gymnastic feats of any kind. As Mr. Crandall's toys can be made to do almost any ridiculous thing, he has called them "Acrobats," and it is just as good a name as any other. There are four acrobats in a box, and each one consists of a body, a head, two arms, and two legs. All these parts are so grooved and notched that they can be put together to suit the child's fancy. They go together much as the blocks do, and, like them when put together, they hold. Then there are long and short grooved strips in each box, which allow the acrobats to be set up in all sorts of ways. When Mr. Crandall sent his first sample box, you ought to have seen how a lot of old "boys" amused themselves with it. Men who are grandfathers took the greatest delight in putting these figures together in strange shapes, and then laughing at them just as children would. Well, that is right; a man should never forget that he was a child once, and probably each one was laughing to think how his children would be pleased. Did not the figures illustrating these Acrobats take up so much room we would show them here, but the publishers, who have the sale of this, the best toy of the century, give the whole thing in the advertising pages, and we advise you to turn to them and learn more about these funny acrobats from the engravings than a long description could tell. We think the boys and girls should hold Mr. Crandall in their esteem as only next to St. Nicholas.

Sunrise.—Bas-relief.

In our mention of the picture called "Sunrise," given last month, we just had room at the bottom of the page to say that it was from a "beautiful bas-relief," and promise to tell more about it. Probably some were puzzled to know what a bas-relief was, and others must have wondered why the little girl had such strange eyes. Yet perhaps the eyes, if nothing else, led them to think that the picture was copied from a piece of sculpture in marble. This was really the case. One of our artists saw this marble work, and being pleased with it he made a copy of it. Besides the figures which stand by themselves, such as the statues and busts, sculptors make works in which the figures are attached to a background of marble or other material. These are called works in relief, or *relievo*, as the Italians call it. In high relief the figures are only attached to the background here and there, and are in places quite free from it; in half relief, the figures project half-way from the background; and in low relief the figures stand out but a little way—less than half. The word for this in French is *bas-relief* (pronounced ba-relief), and is perhaps more generally used than the English *bas-relief*.

Bad Writers.

A great many stories are told about the mistakes of printers, and there are some ridiculous ones that may happen by the use of a wrong letter, but the printers would not make so many blunders if those who wrote for them wrote more plainly. Many noted writers have been celebrated for their horrid hand. The bad writing of the eminent lawyer, Rufus Choate, has often been mentioned as the worst possible; some one said that the word "what" as he wrote it, "looked like a small grid-iron struck by lightning." One of the widely read English journals not long ago had an article on "Wretched Writers," which was mainly devoted to showing the mistakes made by Horace Greeley, as if there were not abundant examples of bad writing in England. It is true that Mr. Greeley would never have succeeded as a writing-master. We have several pieces of his writing which are not so difficult to make out when one gets the hang of it and knows that he made *s*, *a* and *r* all alike, as he did *b*, *p* and *h*. This English journal gives an instance of his bad writing that we had not seen be-

fore. Mr. Greeley was invited to attend a press meeting in a Western state, and sent a letter declining to come. Those who invited him studied over his answer, and this is what they made out of it: "I have hominy, earrots and railroad ties more than I could move with eight steers. If eels are blighted, dig them early. Any insinuation that brick ovens are dangerous to hams gives me the horrors." What he did write was: "I find so many cares and duties pressing on me, that, with the weight of years, I feel obliged to decline any invitation that takes me over a day's journey from home."

It does not seem possible for every one to learn to write an elegant hand, but it is possible for every boy and girl to write a plain hand that can be read without difficulty. The most troublesome letters that come to this office are those of persons who use flourishes, and though the written page as a whole presents a fine appearance, yet it is more difficult to read than the poorest cramped school-boy hand. It very often happens that we can read every part of a letter but the most important—the signature. While you are young, get in the way of writing your name so plainly that there can be no doubt of a single letter in it. It may save yourself and others much trouble in after life.

Aunt Sue's Puzzle-Box.

ANAGRAMS.

- 1. I undid vial.
- 2. Let M. and it.
- 3. O hem her rag.
- 4. She pops the corn.
- 5. Train my mole.
- 6. Pet eider.
- 7. Adored love.
- 8. Is Peter a Piet?
- 9. Crimp feet.
- 10. Clide Inu.

CONCEALED SQUARE-WORD.

I saw him stab and kill a buffalo, entirely for sport, and did "not enter his name on my list of friends;" indeed, I never wish to see him again. ELKCIK.

PI.

Noe tenleg drow hatt I amy kapes,
Neo dink dan volgin edde,
Amy—ought a riflet ropo adn keva—
Ovcrp ikle a nity edes ;
Dan how nae lelt thaw dogo yam gnirps
Morf ehus a revy tillet night? J. C. C.

NUMERICAL ENIGMA.

I am composed of eleven letters.
My 1, 4, 2, 5 is a planet.
My 6, 11, 10, 9 is pretty poor when it blows nobody any good!
My 8, 7, 1 is an article of food.
My 10, 11, 3, 9 is a sort of avenue.
My whole is an American river. H. S. B.

CROSS-WORD.

My first is in father but not in son.
My next is in bread but not in bun.
My third is in purchase but not in buy.
My fourth is in pudding but not in pie.
My fifth is in strike but not in pound.
My sixth is in oval but not in round.
My seventh is in vigor but not in health.
My eighth is in money but not in wealth.
Select the right letter from every word,
And you'll find a name you have often heard.
H. L. MORTON.

DIAMOND PUZZLE.

- 1. Part of a day.
- 2. A vehicle.
- 3. To mark.
- 4. A geometrical figure.
- 5. A disease.
- 6. A girl's name.
- 7. Part of the hand.

PATCHWORK.

Take 1/2 of a hand, 1/4 of a fragment, 1/5 of a third, 1/2 of a lamb, and make an amusing puzzle of the whole.

CHARADE.

My first, a kind of seed
That in my whole's contained;
My next is sharp indeed,
Its wound with blood's soon stained.
My whole is ripe in fall,
Its taste delicious quite,
In shape 'tis like a ball,
With pulp both soft and white. HENRY.

ANSWERS TO PUZZLES IN THE MAY NUMBER.

ANAGRAMS.—1. Furtherance. 2. Kalsomine. 3. Misogamist. 4. Conventional. 5. Centuries. 6. Vocabulary. 7. Implication. 8. Belegners. 9. Elucidation. 10. Throughout.

PI.—The snow-drifts, which have lain so long
Haunting the hidden rocks,
Like guilty ghosts have slipped away,
Unseen, into the brooks.

SYNCPATION.—Slate, late, ate, at, t (tea).

CROSS-WORDS.—1. Hannah. 2. Catalogue.

CONCEALED GEOGRAPHICAL NAMES.—1. Asia. 2. Alaska. 3. Parana. 4. San Francisco. 5. Ohio.

SQUARE-WORDS.—

LOVE	HATE
OVAL	AJAR
VATS	TAPS
ELSE	ERST

although many of them are popped into the scrap-basket as altogether too poor for use.

J. H. W.—It is scarcely worth while to "Pr" well-known proverbs or verses, as one or two words will often give a key to the whole, and "spoil the fun."

BESSIE BENNETT writes to me on the 9th of May, and says: "You just ought to be in the country now; everything is as pretty as can be."—I am just going, Bessie. If there be one thing I love above another it is to see the

Gulliver in Brobdnag.

Perhaps the first questions you will ask will be, "Where is Brobdnag, and who was Gulliver?"—You will not be likely to find Brobdnag on any map or in any gazetteer, for the place, as well as Gulliver, was the work of a gentleman who had a very lively fancy, who described both as if they were real. Over a hundred years ago there appeared a book called Gulliver's Travels, by one Jonathan Swift, better known as Deau Swift, and it was a most interesting story; fifty years ago or less it was printed with pictures as a children's book, as the story was so well told that children could get amusement from it as they do from Robinson Crusoe. But it was not intended as a child's book; the author wrote it to ridicule some of the people and the fashions of his time. The story says that Gulliver was shipwrecked on a strange land called Lilliput, where the people were only six inches high; and it gives a great many amusing adventures that happened to him among these little people. He was first taken prisoner by them, having laid down to sleep near one of their cities. He found upon waking that he could not rise; the little fellows had made him fast by the hairs of his head, as well as by many cords over his limbs. They thus took him captive, and he lived for a while among these little people, doing many strange things. Although Lilliput was a fanciful name, it has become fixed in our language, and we call anything that is small "lilliputian."

After a while Gulliver escaped from Lilliput and reached home, but soon after he went on another voyage and got left by his ship in the land of the Brobdnagians, who were a race of giants, as much larger than he was as he was larger than the Lilliputians, and his adventures here were quite as strange and as laughable as those among the pigmies. He was taken possession of by a farmer, who put Gulliver in the care of his daughter, a bonnie lass, who had the beautiful name of Glumdalclitch. You can imagine the size she was said to be by the story that she had a box made in which to carry Gulliver about, like a pet bird. Everything in Brobdnag, according to this history, was as large in proportion as the people, or, to be exact, trees, birds, hailstones, and all other natural objects were eighteen hundred times larger than in England. After a while he went to court and lived with the king and queen. One of the royal attendants had a spite against Gulliver, and as he was walking in an orchard shook the trees, and the apples, each nearly as large as a barrel, came near killing him. He had wondrous battles with the linnets and other small birds of the country, as well as with a frog. For exercise he used to row in a boat which the princess hung up in her closet to dry after he had used it. But perhaps some of you may some day come across this quaint old book, which though written to ridicule the court of England, and princes and public men now long dead, is very bright and amusing for the way in which the story is told. Some very beautiful editions of this famous book have been published, with fine illustrations. The picture here given is from one of these volumes, and is by Morten.



GULLIVER BEFORE THE CITIZENS OF BROBDNAG.

ALPHABETICAL ARITHMETIC.—

142)628397(4125 (Key: Wicked boys.)

ILLUSTRATED DOUBLE ACROSTIC.—Water-melon.

W- igwa -M
A- ntelop -E
T- owe -L
E- ighty-tw-O
R- ai -N

AUNT SUE'S NOTICES TO CORRESPONDENTS.

EFFIE M. G.—I am glad you "all enjoy the puzzles so much." I can not do less than thank the dear children when they take the trouble to write and send me puzzles,

baby leaves rocked in their bud cradles by the May zephyrs to the sweet music of happy birds. Bessie squares LOVE five times and HATE ten times; she seems to find it easier to "get square" with hate than with love.

MINNIE, HESTER, AND ETTIE.—Thanks. I have a superabundance of numerical enigmas, but, under the circumstances, yours shall be prepared for publication.

Thanks, for letters, puzzles, etc., to M. Cator, Isaiah S. R., M. C. Stear, Mattie J., W. J. K., D. H. L., Ruthie A. B., Frank L. H., and Nellie Van.

All contributions for the PUZZLE-BOX should be addressed to AUNT SUE, P. O. Box 111, Brooklyn, N. Y.

farmer who first had Gulliver used to take him about and exhibit him, just as Barnum in later years did with Tom Thumb. The picture shows one of these exhibitions before the wise people and dignitaries of Brobdnag. His mistress, Glumdalclitch, is showing off her pet, who is evidently astonishing the natives. A portion of the box in which the lady carried Gulliver around is seen at one side, and she holds in her hand one of the straws of that remarkable country, which, according to Gulliver, served him for a lance or spear. If the persons who are witnessing his exhibition are fair specimens of the citizens of Brobdnag, we do not wonder that he was glad to leave the country, notwithstanding that he was a favorite with the king and the royal family.

Life Insurance.

MODERN science and civilization have achieved no prouder triumph than in the discovery and practical application of the principle of life insurance. As a discovery, it ranks with the most wonderful inventions of the century; as a beneficent institution, it outranks and overshadows every other that has been devised by the wit of man. The unwritten record of its benefactions are one grand epic, telling of the triumphs of human love over sorrow and death. The visible creations and monuments of its power are the strongest, purest, and most enduring financial institutions of the age.

Among these, conspicuous alike for its age, its stability, and its liberality, stands the United States Life Insurance Company of this city. Organized in 1850, when life insurance was an experiment in America, and little more than an experiment anywhere, this company comes forth from the trials and vicissitudes of nearly a quarter of a century with \$4,253,866.48 of assets, a surplus as to policy-holders of \$915,443.46 and a record without spot or blemish.

Twenty-five years is a long time in the history of American life underwriting. In that time, what financial changes, what social progress, what political revolutions have transpired. Through what storms and perils has every great moneyed corporation of the country passed—either to oblivion, or to a secure place in the confidence of men.

The founders of the United States Life Insurance Company were among the pioneers of life insurance in this country. Time and space are wanting with us to tell the story of their early struggles, of their patience, and a faith—a patience that “worked” rich experience, and a faith gloriously illustrated by works.

They contended with difficulties that to less sturdy souls would have been insurmountable. They explored untried regions, and wrought with unknown material. They builded with the trowel in one hand and the sword in the other, but they builded better than they knew. They laid the foundations, and sprung the arches, and established the economy of a building that has outlasted their lives, and promises to outlast the memory of their names—a building beneath whose staunch roof-tree more than 19,000 families are sheltered and secured.

Avoid Lead and Zinc Poison and Iron rust, by using **TIN-LINED LEAD PIPE**. It is the best Pipe for water, and is highly recommended. Price 16½ cents a pound, for all sizes. Descriptive Pamphlets sent by mail free. Colwell Lead Co., 313 Centre St., New York.

(CIRCULAR.)

Consumers Importing Tea Co.,
No. 8 Church Street,
P. O. Box 5,509. New York City.

This is a combination of capitalists to supply the consumers of Teas throughout the United States on the mutual principle.

We have experienced agents in all the best districts of China and Japan to select Teas especially for our trade.

We expect every consumer of Teas to render us all the assistance they can in carrying out our enterprise, as we make a specialty of **SUPPLYING CONSUMERS ONLY** (and allow no middlemen to make any profit on our importations), which will enable us to supply them with Teas at prices lower than have ever been known, and of those fine qualities that seldom reach the interior, being sold only in the large cities and among the very wealthy.

Hoping the consumer will take an interest in our enterprise, and send at once for a circular with full explanations of how to proceed to obtain our goods, we remain,

Most respectfully yours,

Consumers Importing Tea Co.,
No. 8 Church Street,
P. O. Box 5,509. New York City.

Entered, according to Act of Congress, in January, 1874, by the Consumers Importing Tea Co., in the Office of the Librarian of Congress, Washington, D. C.

\$290 Piano. Circulars free. U. S. Piano Co. 810 Broadway, N. Y.

FAIRBANKS' STANDARD

HAY,
CATTLE,
COAL,

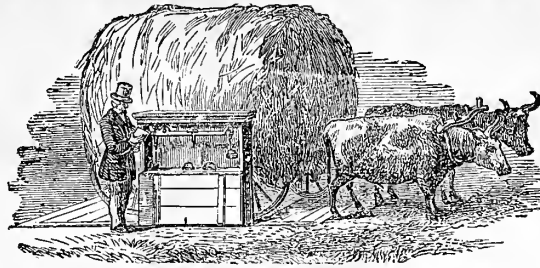

PLATFORM,
COUNTER,
FAMILY,

S C A L E S .

SEND FOR PAMPHLET TO

FAIRBANKS & CO., 311 Broadway, New York.

SUITS, \$10, \$15, \$20. SUITS, \$25, \$30, \$35, SUITS, \$40, \$50, \$60.
The stock for the present season is of unparalleled extent, and embraces all the most fashionable styles for all occasions and occupations.
ORDERS to measure promptly executed at Moderate Prices.

CLOTHING
OVERCOATS
for Spring in all New Fabrics, Colors, and Mixtures.
\$5, \$10, \$12, \$15, \$20, to \$30.

CLOTHING
Boys' Suits,
the Favorite Designs and Most Fashionable Materials for all Ages,
\$3, \$5, \$10, \$15, \$20 to \$25.

FREEMAN & BURR.

CLOTHING WAREHOUSES,
138 and 140 Fulton St., New York.

ORDERS BY MAIL.

FREEMAN & BURR'S NEW SYSTEM for Self-Measure, of which thousands avail themselves, enables parties in all parts of the country to order direct from them, with the certainty of receiving the most **Perfect Fit Attainable.**

RULES FOR SELF-MEASURE, Samples of Goods, Illustrated Book of Fashions, and Prices Sent Free on application.

Highest Premium (Medal) Awarded by AMERICAN INSTITUTE,



The **ASBESTOS ROOFING** is adapted for steep or flat roofs in all climates, and can be cheaply transported and easily applied. **ASBESTOS ROOF COATING**, for restoring and preserving roofs. **ASBESTOS PAINTS**, for Roofs, and all outside work. **ASBESTOS CEMENT**, for repairing leaks of all kinds on Roofs. **ASBESTOS BOILER FELTING**. **ASBESTOS BOARD** and **PAPER**, SHEATHING FELTS, etc. These materials are prepared ready for use, and are put up for shipment to all parts of the world. Send for descriptive Pamphlets, Price Lists, etc., etc. **LIBERAL INDUCEMENTS TO GENERAL MERCHANTS AND DEALERS.**
Patentee and Sole Manufacturer, H. W. JOHNS, 87 Maiden Lane, N. Y. ESTABLISHED 1858.

Parents, reduce your **SHOE** Bills two-thirds, by buying **SILVER-TIPPED SHOES.**



GREAT WESTERN GUN WORKS
PITTSBURGH PA
Rifles, Shot Guns, Revolvers, Pistols, Ammunition, Fishing Tackle, etc. For Price-list, see page 157, April No. Am. Agriculturist, or address, with stamp,
GREAT WESTERN GUN WORKS,
285 Liberty St., Pittsburgh, Pa.

HALF PRICE The Science of Health.
Illustrated and Independent. Not medical, but for the people. \$2.00 a year, 20 cts. a No. On Trial 3 mos., 25 cts. Address **S. R. WELLS, Publisher,** 389 BROADWAY, N. Y. Mention Am. Agriculturist.

SOMETHING NEW in relation to Boys' Boarding School. 8th year. No extras. All books furnished free to scholars. Catalogues free. Address **HIRAM H. POST, Prin.,** Sing Sing, N. Y.



If you have any Cherries, you certainly need a Family Cherry Stoner, made by **D. H. GOODELL,** 99 Chambers St., New York, for just one dollar.

GEO. A. PRINCE & CO.

ORGANS & MELODEONS.

The Oldest, Largest and Most Perfect Manufactory in the United States

53,000

Now in use.

No other Musical Instrument ever obtained the same popularity.

Send for Price-Lists. Address

BUFFALO, N. Y.

"The Verdict."

GOOD CABLE SCREW WIRE

Boots and Shoes

BETTER THAN PEGGED or SEWED.

\$600 A MONTH made honestly with Stencil and Key-Check outfits. Catalogue and samples free. **S. M. SPENCER,** 117 Hanover St., Boston, Mass

B. K. BLISS & SONS' REMOVAL.

In consequence of our rapidly increasing business, and in sufficient accommodations in our former locality, 23 Park Place and 20 Murray Street, we have been under the necessity of making another removal, and are happy to announce to our friends and patrons, that we have leased the large and beautiful IRON BUILDING,

No. 34 Barclay Street,

a few doors west of Broadway, opposite the new post-office, which has been fitted up in a most convenient manner, to accommodate the various branches of our business. The additional room acquired by our removal, will give us seven floors, each 25 by 100 feet, and will enable us to systematize our business that we hope to be able hereafter to execute all orders, with which we may be favored, immediately upon their receipt, and prevent the delay, which has sometimes been unavoidable during the busy season of the year, for want of room.

In connection with our trade in seeds and bulbs, we purpose to make large additions to our stock of horticultural requisites, useful as well as ornamental, consisting of garden implements and rustic work of every description, vases and flower pots in iron and terra cotta, ornamental iron work, for the lawn, conservatory, or the window garden, lawn mowers of all sizes, suitable for the city lot or the most extensive lawn, descriptive circulars of which will be mailed to all applicants. We take the present opportunity to thank our many friends for their many favors and liberal patronage, and hope to be favored with a continuance of the same.

B. K. BLISS & SONS, P. O. Box 5,712, N. Y.

Turnip Seed by Mail.



The following varieties, the quality of which can not be excelled, will be mailed post-paid to any address in the Union upon receipt of price enclosed. Early White Dutch, White Strap-leaf, Red-top Strap-leaf, Yellow Aberdeen, Long White or Cow-horn, Improved American Ruta-baga, Carter's improved Swede, Skirving's Improved Swede, Long White French, Sweet German, 10 cents per ounce, 25 cents 4 ounces, 75 cents per pound. Large Yellow Globe, 10 cts. per ounce, 30 cts. 4 ounces, \$1.00 per pound. Prices for larger quantities to dealers, either in bulk or packets for retailing, will be given upon application. Address

B. K. BLISS & SONS, P. O. Box, 5,712, No. 34 Barclay Street, New York.

RYDER'S AMERICAN

Family Fruit Drier.

Fruit prepared on THE AMERICAN FRUIT-DRIER has taken the FIRST PREMIUMS wherever exhibited. The apparatus has been thoroughly tested two years, has given entire satisfaction, and its use is rapidly extending wherever it is known.

With the American Fruit-Drier surplus fruit of every kind, and also that which from over ripeness or inferior size or quality is unfit for marketing in the unprepared state, can all be converted into a marketable commodity, which, from its excellence, will command the highest price. Such fruit as is prepared by this means sells readily at an average of fifty per cent. more than ordinary dried fruit. Illustrated circulars giving a full description of the above mailed free to all applicants. Address:

B. K. BLISS & SONS, Agents.

P. O. Box 5712. 34 Barclay St., New York.

Turnip Seeds by Mail.

Early White Flat Dutch, Purple Top, Yellow Aberdeen, White French, White Globe, Early White, Yellow Stone Turnip Seeds, Purple Top, Golden Globe, and White Ruta Baga Turnip Seed. Mailed to any address in the Union, on receipt of 75c. per lb., 10c. per oz. Address

HENRY A. DREER, Seedsman,

713 Chestnut St., Philadelphia, Pa.

Cabbage and Celery Plants.

Premium Flat Dutch and Drumhead Savoy Cabbage Plants, true to name, 50c. per 100, \$4 per 1,000. Incomparable Dwarf, White Solid Boston Market, and White Sandringham Celery, 75c. per 100, \$5 per 1,000; \$1 per 100 by mail. Address P. T. QUINN, Newark, N. J.

CABBAGE PLANTS.—Half a million super plants now ready. Eight best varieties, carefully packed, \$2.50 per 1,000, \$20 per 10,000. TILLINGHAST BROTHERS, Factoryville, Wyoming Co., Pa.

FRUIT AND ORNAMENTAL TREES!

LARGE STOCK. LOW RATES. STANDARD PEAR-TREES A SPECIALTY. AGENTS WANTED Address

E. MOODY & SONS, Lockport, N. Y

NIAGARA NURSERIES, established 1839.

GAWTHROP'S IMPROVED HYDRAULIC RAMS. Send for Illustrated Circular and Price-List. A. GAWTHROP & SON, Wilmington, Del.

PARTIES having for sale ANGORA GOATS, suitable for breeding purposes, address, with full particulars, JARVIS & CO., 29 Broadway, New York City.

Tongue-Lolling Bits.

We make Bits to prevent the above bad habit. \$2, \$3, or \$4, for cash with order, or C. O. D. Hand-forged Bits made in any style to order. Patentes of the **BALDWIN BIT**, for side pullers and hard mouths. \$2, \$3, and \$4. Also agents for the **MARTIN BIT**. See adv. in "Fur, Field, and Farm," and "Wilkes' Spirit of the Times." **JOS. BALDWIN & CO., Newark, N. J.**

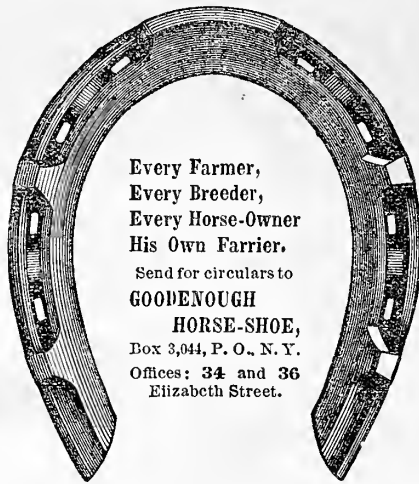

Every Farmer,
Every Breeder,
Every Horse-Owner
His Own Farrier.

Send for circulars to
GOONENOUGH
HORSE-SHOE,
Box 3,044, P. O., N. Y.
Offices: 34 and 36
Elizabeth Street.

Prizes for Essays on Jersey Cattle.

The American Jersey Cattle Club offers three Prizes, \$250, \$150, \$100, for best three Essays on Jersey Cattle. MSS. to belong to the Club, and to be submitted before December 1st, 1874, to Chairman of Committee.
J. MILTON MACKIE, Great Barrington, Mass.

Essex Pigs.

No other breed kept on the farm. I can furnish pairs or trios not akin. No poor pigs sent out. Prices reasonable. Orders respectfully solicited. Address

JOSEPH HARRIS,
Moreton Farm,
Rochester, N. Y.

Automatic PUMPS.

Water driven to any height and distance by compressed air. Country houses supplied cheaply and certainly for bath-rooms, water closets, hot and cold water faucets, etc. Plenty of fresh water for stock on farms. Address **HARTFORD PUMP CO., 41 Trumbull St., Hartford, Conn.** Agent for New York and vicinity, **MASON C. WELD,** at the Agricultural Warehouse of R. H. Allen & Co., 189, 191 Water St., where working apparatus may be examined.

Halladay's Improved Wind-Mill.

PERFECTLY Self-Regulating. The Best, Cheapest, most Durable and Popular Mill made. Manufactured under the immediate supervision of Inventor 18 years. Two million dollars' worth now in use. Send for Catalogue. **U. S. WIND ENGINE & PUMP CO. BATAVIA, ILL.**

LIVINGSTON & CO., Iron Founders, PITTSBURGH, PA.

Manufacturers of Light Grey Iron **CASTINGS,** For Agricultural Implements, Light Machinery, and Miscellaneous Articles generally. **Requiring a Soft and Strong Iron.** Our arrangements for Low Freight to all parts of the country enable us to furnish Good Castings as low as any works East or West.

FOUNTAIN PUMP. GARDEN ENGINE AND FIRE EXTINGUISHER.—For Washing Windows, Carriages, etc. Protects Buildings from Fire, and Trees, Vines, etc., from Insects. Throws water 50 ft. Easily carried. No Dwelling, Country Home, or Factory should be without the Fountain Pump. Send for large Illustrated Circular. **J. A. WHITMAN, Sole Proprietor and Manufacturer, Providence, R. I.**

Factory Churns.

At the urgent request of some of the prominent Dairymen of the country, we have designed and made two sizes of **FACTORY CHURNS** which we believe to be every way adapted to the wants of Butter Factories and large Dairies where power is used.

The new No. 8 is intended to churn from 50 to 75 gallons of cream, and the No. 9 from 75 to 150 gallons at a time.

They are just the article needed, and may be obtained through any of our Agents or directly from us.

Prices and details sent on application to the **Sole Manufacturers,** **PORTER BLANCHARD'S SONS,** Concord, N. H.

GENUINE Peruvian Guano.

FARMERS, AGRICULTURISTS, and DEALERS in Fertilizers have now an opportunity of obtaining this valuable manure in small or large lots, at importers' prices, by applying to the Special Agency just established for the purpose of delivering GENUINE Peruvian Guano to consumers at any accessible port or railway station in the country. Full particulars given in circular mailed free on application to

R. BALCAZAR,

No. 53 Beaver Street, New York.

REFERENCES BY PERMISSION:

Messrs. HOBSON, HURTADO & Co., Financial Agents of the Peruvian Government, 52 Wall Street, New York. **Moses TAYLOR,** Pres. National City Bank, 52 Wall St., N. Y. **J. C. TRACY,** Esq., Peruvian Consul, 26 1/2 Broadway, N. Y.

Farm Implements AND FERTILIZERS.

Buy the Best and at Lowest Prices.



Agricultural Almanac Sent Free.

H. B. GRIFFING,

58 & 60 COURTLANDT STREET, N. Y.

FOR SALE--MANURE

from 180 horses for a year. For particulars, apply to the **TROY & LANSINGBURGH R.R. CO.,** Lansingburgh, N. Y.

PENNSYLVANIA Agricultural Works.

A. B. FARQUHAR, Proprietor, Manufacturer of the celebrated Farquhar Threshing Machines, steel plows, cultivator teeth, and standard implements generally. Send for circular. Please address **A. B. FARQUHAR, York, Pa.** Or 56 Beekman St., New York.



For full particulars, address **ENGLE, KELLER & CO.,** Lancaster, Pa.

Sugar Cane and Sorgho Machinery,

Steam Engines, Horse Powers, Farm Mills, etc.

Manufactured by **GEO. L. SQUIER & BRO.,** Catalogues free **Buffalo, N. Y.**

QUINBY'S NEW STOKER.—Best method yet devised for quieting bees. Can be sent by mail in two parts, price \$1.75. By express \$1.50. Send for circular and price list. **M. Quinby, St. Johnsville, N. Y.**

THE CHAMPION
Hickok's Patent Portable
KEYSTONE CIDER and WINE MILL.

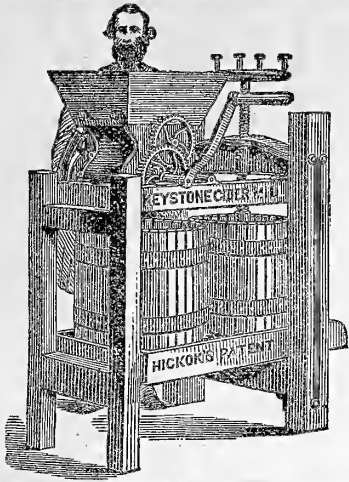

THE BEST MACHINE EVER INVENTED.

I make also two sizes of superior Presses for Berries, etc. If your merchant does not keep them, tell him to send for one for you, or write for one yourself. Don't buy any other until you see this. Send for a circular. **W. G. HICKOK,** Harrisburg, Pa.

CIDER MILLS.

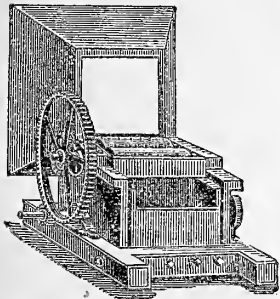

The most perfect Cider Apple Grinder in use, in grinding fast and fine, and giving the best satisfaction.

Price, \$40.

I have also the easiest, handiest, quickest working, and most powerful Press in use.

Send for Descriptive Circulars.

Address **MARCUS P. SCHENCK,** Fulton, N. Y.

The Superior Hay Spreader
(Improved and perfected for season of 1874.)

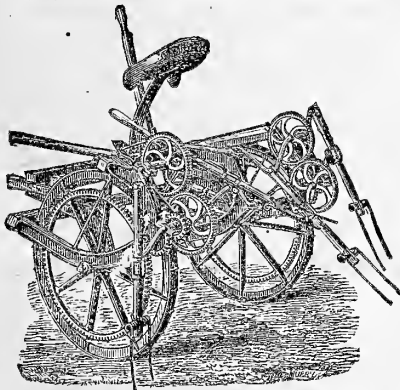

This machine will do the work of ten men. It is the lightest draft machine ever built, one horse working it easily. It has taken first premiums wherever exhibited. Send for a descriptive circular. The Superior Spreader is unsurpassed in beauty, workmanship, and durability. Manufactured by

THE HIGGANUM MANUFACTURING CO., Higganum, Conn.

Straw Preserving Thresher.



This Machine leaves the straw straight and unbroken, when it can gain be put into bundles, making it more valuable for market. **WHEELER & MELICK CO.,** Sole Manufacturers, Albany, N. Y. Send for circular.

BLAKE'S PATENT
STONE & ORE BREAKER.

New Pattern, with Important Improvements & Abundant Strength.

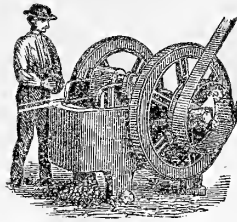

For reducing to fragments all kinds of hard and brittle substances, such as **STONE** for making the most perfect **McADAM ROADS**, and for making the best **CONCRETE**. It breaks stone at trifling cost for **BALLASTING RAILROADS**. It is extensively in use in **MINING** operations, for crushing

IRON, COPPER, ZINC, SILVER, GOLD, and other ORES. Also for crushing **Quartz, Flint, Emery, Corundum, Feldspar, Coal, Barytes, Manganese, Phosphate Rock, Plaster, Soapstone, etc.** For Illustrated Circulars and particulars, address

BLAKE CRUSHER CO., New Haven, Conn.

Persons visiting New York, can be shown a crusher in operation at 137 Elm Street.

No More Loose Bolts and Nuts.

THE CELEBRATED "CUMMING" LOCK-NUT, Patented June 16, 1868.

No More Rattling **CARRIAGES** and **WAGONS.**
No More Dropping Down of **SHAFTS.**
No More Lost Bolts from **REAPERS** and **MOWERS.**

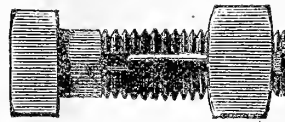

No More Flying Teeth from **THRESHERS.**
No More Bills for Repairs Continually. SEND FOR PRICE-LIST AND CIRCULARS TO

THE LOCK-NUT AND BOLT CO. OF N. Y., No. 17 Dey Street, New York.

Licenses granted to Manufacturers of Agricultural Machines, Carriages, etc.

TWO GOLD MEDALS

For a "Stone and easy movement of horses, its rods less than 1 1/2 inches per hour. Mechanical Construction of the very best kind, thorough and conscientious workmanship and material in every place, nothing shoddy, excellent work, etc." as shown by Official Report of Judges: Threshers, Separators, Raking Mills, Wood Saws, Seed Sowers and Planters, all of the best in the United States, and the only one in the world. **MINARD HARDER, Cobden, Ill., U.S.A.**

At Great National Trial, at Auburn, N. Y.

"BEST EVER MADE"

HARDER'S Premium Railway Horse Power, and Thresher and Cleaner, awarded THE FIRST PRIZE.

AWARDED THIS MACHINE

MEDAL MACHINES.
NEW YORK STATE AGRICULTURAL WORKS.

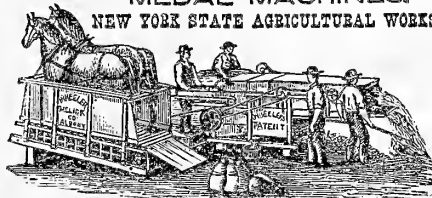

WHEELER & MELICK CO.,
Patentees and Manufacturers of

RAILWAY, CHAIN and LEVER HORSE POWERS, THRESHERS and CLEANERS, THRESHERS and SHAKERS, CLOVER HULLERS, FEED CUTTERS, ITHACA WHEEL HORSE RAKES, HORSE PITCHFORKS, SHINGLE MACHINES, STRAW PRESERVING RYE THRESHERS, &C., &C.

Send for Circular. **ALBANY, N. Y.**

THE UNION RAILWAY
HORSE POWER.

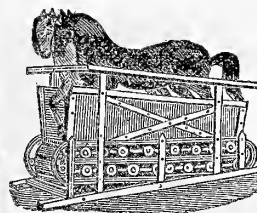

This superior Power produces much more power than other railway powers, and with very much less elevation. Also, Improved Threshers, Farm Grist Mills, etc., etc.

Send for Descriptive Circular. Address **WM. L. BOYER & BRO.,** Philadelphia, Pa.

AGENTS WANTED for the cheapest and best hay, straw, and stalk cutters. **Not to be paid for till tried on the farm** and found satisfactory. Circulars free. **Warren Gale,** Chicopee Falls, Mass.

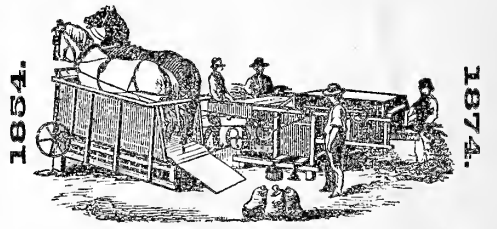

The Peerless Thresher and Cleaner. Price \$225 and \$245. The Peerless, Straw Preserving Rye Thresher, Overshot. Price \$160.

We make the above a specialty. Railway and Lever Powers. **E. GILL & SON,** Trenton Agricultural Works, Trenton, N. J.

SPRING STEEL TOOTH. **ITHACA HORSE RAKE.**

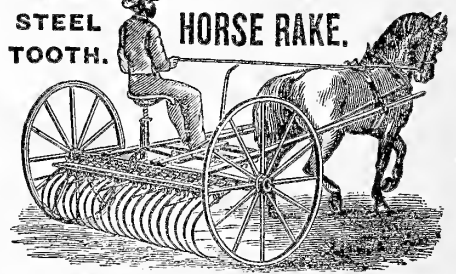

EXCELS ALL OTHERS. Thousands in use giving entire satisfaction. Manufactured by **WHEELER & MELICK CO.,** Albany, N. Y. **WILLIAMS BROS.,** Ithaca, N. Y. **YOUNGLOVE, MASSEY & CO.,** Cleveland, O. **GRAND RAPIDS MFG. CO.,** Grand Rapids, Mich.



FOUST'S PATENT HAY LOADER, manufactured at the **MEADVILLE AGRI. WORKS, Meadville, Pa.** Warranted to elevate a ton of hay from the winnow to the wagon in five minutes, and take it as clean as by the hand fork, and to be adapted to all ordinary meadow land. Send for Descriptive Circulars.

Sayre's Bale Tie Fastener.

For drawing iron ties and wire tight on bales of Cotton and Hay. *Simple and durable.* Made of wrought iron. Price of Machine, \$5. State and County Rights for sale. For circulars and terms, send stamp to **R. STOKES SAYRE,** Cartersville, Ga.

Reliable Turnip Seeds.

SHAMROCK SWEDE, Am. Improved Ruta-Baga, Carter's Imperial, Laing's Swede, Cow Horn, Yellow Aberdeen, Tankard, Red Top and White Top Strap Leaved—at 10c. per oz., 25c. per qr. lb., 75c. per lb.

YELLOW GLOBE and Yellow Stone—at 10c. per oz., 30c. per qr. lb., \$1 per lb., 8c. per lb. for postage if ordered by mail.

SEED CATALOGUES and circulars of Agricultural Implements, will be sent on receipt of Postage Stamp.

R. H. ALLEN & CO.,

P. O. Box 376. 189 & 191 Water St., NEW YORK.

Vegetable Plants.

NOW READY.

Cabbage, In variety... \$.50 per 100, \$ 1.00 per 1,000, \$30.00 per 10,000
Cauliflower, " ... 1.00 " 6.00 " 50.00 "
Celery, "50 " 4.00 " 30.00 "

10c. extra per 100, by mail.

JOHN WHITE, Communipaw Ave., Jersey City, and 67 Nassau St., New York City.

PATENT GRAPE PICKER

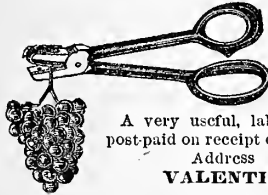

A very useful, labor-saving article. Sent post-paid on receipt of \$1.

Address VALENTINE & CO., Bristol, Conn.

TATEM & DAVENPORT, Produce Commission Merchants.

Office, No. 1 Delaware Ave. Market, PHILADELPHIA, PA.
Southern Produce a specialty. Correspondence solicited. Consignors advised daily.

Established 1862.

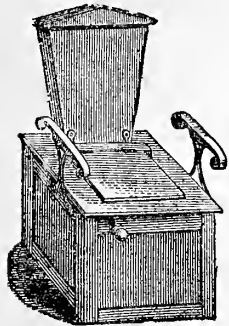

The Earth Closet.

Every home should have one. Can be used in any room, without inconvenience from bad odor. Invaluable in case of sickness.

PRICE:

- No. 2, Blackwalnut... \$11.00
- " 3, Pine..... 9.00
- " 5, Blackwalnut... 20.00
- " 6, Pine..... 15.00

Manufactured and sold by H. B. GRIFFING, 60 Cortland St., N. Y.

New York College of Veterinary Surgeons, INCORPORATED 1857.

Lectures for 1874 will commence about the middle of October and continue until the last of February, 1875.

Fees: Matriculation, \$5; Faculty, \$120; Graduation, \$35; Dissecting, \$5; Address for Circulars, A. F. LAUTARD, V.S., M.D., Sec'y., 205 Lexington Ave., New York.

THE PULSOMETER.



The simplest, most durable, and effective steam pump now in use. Will pump gritty or muddy water without wear or injury to its parts. It can not get out of order.

C. HENRY HALL & CO., 20 Cortlandt Street, New York City.

BRANCH DEPOTS:
104 Sudbury St., Boston, Mass.
1327 Market St., Philadelphia, Pa.
59 Wells St., Chicago, Ill.
South Western Exposition, New Orleans, La.
811 and 813 North Second St., St. Louis, Mo.

Lovejoy's New Style GLASS CUTTER AND PUTTY KNIFE

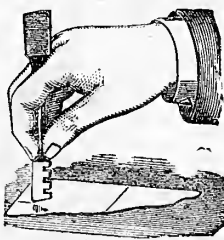

Cuts glass better than a diamond. Everybody should have one. Any child can use it. Sent to your address on receipt of 50 cents and stamp by ALVAN L. LOVEJOY, 229 Washington St., Boston, - - - Mass. Liberal discount made to dealers.

A GENTS WANTED to sell our justly celebrated Articles for Ladies' wear. Indispensable and absolutely necessary. **10,000 SOLD MONTHLY.** They give comfort and satisfaction. No female can well do without them. Sample sent, on receipt of \$2.00, FREE. Send for Illustrated Circular. LE PERLE RUBBER CO., 90 Chambers St., New York.

LIFE AND PUBLIC SERVICES OF Charles Sumner.

By C. EDWARDS LESTER.

The second edition ready. Book canvassers can still secure territory, and make money in spite of "hard times." Send for Press notices and Terms.

UNITED STATES PUBLISHING CO., 18 University Place, New York.

20th Thousand in Press.

AGENTS WANTED for the new book, LIFE AND ADVENTURES OF Kit Carson

by his comrade and friend, D. W. C. Peters, Brevet Lt. Col. and Surgeon, U. S. A., from facts dictated by himself. The only TRUE and AUTHENTIC life of America's greatest HUNTER, TRAPPER, SCOUT and GUIDE ever published. It contains full and complete descriptions of the Indian tribes of the FAR WEST, as seen by Kit Carson, who lived among them all his life. It gives a full, reliable account of the MODOCs, and the MODOC WAR. As a work of HISTORY, it is invaluable. A grand opportunity for agents to make money. Our illustrated circulars sent free to all applicants. Write and secure territory at once. DUSTIN, GILMAN & CO., Hartford, Conn.

BOOK AGENTS WANTED to sell the NEW BOOK TELL IT ALL

By Mrs. Stenhouse, of Salt Lake City,—for 25 years the wife of a Mormon High Priest. Introduction by MRS. STOWE. It tells of the "inner life," mysteries, ceremonies, secret doings, &c., of the Mormons. "As a wide-awake Woman sees them." It is actually overflowing with spicy revelations, humor, pathos, and good things for all. Ministers say "God speed it." Eminent women endorse it. Everybody wants it; and it is selling far and wide by thousands. Over 3,000 outfits were ordered in advance of publication, and Agents are selling 15 to 25 a day! We want 5,000 more Agents 1/0W—men or women. (Ladies say this book goes like hot cakes) and we will mail Convancing Book and whole outfit FREE, to any one who will canvass. Our large descriptive pamphlets with full particulars, terms, &c., sent free to any one. Reader! send for them. Address, A. D. WORTHINGTON & CO., Hartford, Conn.

AGENTS WANTED FOR THE CENTENNIAL GAZETTEER OF THE UNITED STATES.

No book has ever been published, of such universal interest to the American people. It appeals to no particular class alone, but to all classes; to men and women of all professions, creeds, occupations, and political opinions; to Farmers, Lawyers, Business Men, Mechanics, Physicians, Politicians, Teachers, Students, Manufacturers, Salesmen, men of learning, and men who can only read, to old and young. All want it as a book of constant reference, and to preserve for their children and children's children, as the only complete and reliable work, showing the gigantic results of THE FIRST ONE HUNDRED YEARS OF THE GREATEST REPELLED THE WORLD EVER SAW. It is not a luxury, but a necessity to every well-informed American citizen. Agents make \$100 to \$300 per month. Send for a circular. ZIEGLER & MCCURDY, Philadelphia, Pa., or Springfield, Mass.

AGENTS WANTED TO SELL "JOE JOHNSTON'S BOOK," NARRATIVE OF

Military Operations directed during the late War between the States by JOSEPH E. JOHNSTON, General, C. S. A.

ILLUSTRATED BY NUMEROUS STEEL PORTRAITS AND MAPS.

Octavo; price in Cloth, \$5; Sheep, \$6.

Gen. JOHNSTON'S book is highly recommended by Gen. SHERMAN, Gen. HOOKER, and other Union Generals. Sold by subscription. Apply for terms and territory to

D. APPLETON & CO., Publishers, 549 & 551 BROADWAY, NEW YORK.

No Man's Son; or, Bound to Win. Albert W. Aiken's great story in Munro's "Girls and Boys of America."

Send a postal card, with your address, for a sample copy, free. Address GEORGE MUNRO, Publisher, P. O. Box 5657, 84 Beckman Street, New York.

MAGIC PHOTOGRAPHS.

Wonderful! Curious! Amusing! 25 cents a package; 5 assorted packages \$1; one dozen assorted packages \$2. Sent to any address, postage paid, on receipt of price. Address PUZZLE COMPANY, 755 Broadway, New York.

FIRST Premiums awarded by Amer. Inst., 1870. MICROSCOPES.

Illustrated Price-List sent free on application. MAGIC LANTERNS. Catalogue, priced and illustrated, sent free.

T. H. McALLISTER, Optician, 49 Nassau-st., N. Y.

BAIRD'S BOOKS

For Practical Men.

My new revised and enlarged Catalogue of PRACTICAL AND SCIENTIFIC BOOKS, 96 pages, 8vo., will be sent, free of postage, to any one who will favor me with his address.

HENRY CAREY BAIRD, Industrial Publisher, 406 Walnut St., Philadelphia.

THE PATENT

ARION PIANO-FORTE

Excels all others in Tone and Durability, and in Elegance of Finish they are Unsurpassed.

These Pianos are used exclusively in the New York Conservatory of Music, and are recommended by the Profession and the Press throughout the United States.

Before purchasing, write for Illustrated Pamphlet, and mention the *Agriculturist*. ARION PIANO-FORTE CO., No. 5 East 14th Street, New York City.

THE SABBATH.

Greatest and Latest of Church Choir Books. For all denominations. \$13.50 a doz. Sample copy, \$1.25

CLARKE'S NEW METHOD FOR THE PIANO-FORTE. THE BEST OF INSTRUCTION BOOKS. Has the endorsement of all good teachers who have examined it. Sent by mail, \$3.75.

"THE AMATEUR."

THE GREAT MUSICAL MONTHLY! ELEVEN pages of new music—and NINE pages of musical matter in each number. Sample copy, 10 cts. Subscription, including beautiful CHROMO, \$1.00 per year.

LEE & WALKER'S MUSICAL ALMANAC. Sent free to any address.

GETZE'S SCHOOL FOR THE ORGAN. "THE UNRIVALLED INSTRUCTOR." The best work for teachers and pupils. Sent by Mail, price, \$2.50.

Lee & Walker, 922 Chestnut St. Philadelphia.

\$6.00 WORTH OF

MUSIC

FOR 50 CENTS.

BRANARD'S MUSICAL ALBUMS. The cheapest Musical Publications in the world. In Nine numbers. Price 50 cents each. No. 1, contains eighteen vocal and instrumental pieces. No. 2, Twenty choice Songs and Quartets. No. 3, Twenty-four New Comic Songs. No. 4, Twenty-three New Songs and Quartets. No. 5, Eighteen beautiful Piano pieces. No. 6, Twenty-five Sacred Quartets. No. 7, Nineteen Song and Piano pieces. No. 8, Nineteen Popular Comic and Sentimental Songs. No. 9, Eighteen Vocal and Instrumental pieces. Each number contains Forty-eight pages, six of music size, neatly bound. Mailed post-paid on receipt of 50 cents each.

S. BRANARD'S SONS, Publishers, CLEVELAND, OHIO.

SONGS of GRACE & GLORY

The very best Sunday-School Song Book. By W. F. SHERWIN and S. J. VAIL. 160 Pages Splendid Hymns, Choice Music, Tinted Paper, Superior Binding. Price in Boards, 35c.; \$30 per 100. A Specimen Copy in Paper Cover mailed for Twenty-five Cents. Publishers, HORACE WATERS & SON, 481 Broadway, New York. P. O. Box 3567.

"EDEOGRAPHY." A new book on the art of writing by Sound; a complete system of Phonetic Short Hand—the shortest, most simple, easy, and comprehensive, enabling any one, in a short time, to report trials, speeches, sermons, &c. The Lord's Prayer is written with forty-nine strokes of the pen, and 140 words per minute. The unemployed should learn this art. Price, by mail, 50 Cts. Agents wanted. Address T. W. EVANS & Co., 139 S. Seventh Street, Phila., Pa.

The Menmonites.—These people are now arriving at their new Western homes. A few weeks ago, a body of three hundred and fifty arrived in New York, bringing a common fund of \$60,000, and immediately started for their destination, in Nebraska. The industrious, frugal habits of these people, with their strong religious character, will make them as sturdy, persevering, and finally as successful a body of citizens as could be wished for.

Exportation of Live Cattle.—A recent experiment in shipping live cattle from New York to England failed, not for want of profit, but because of loss of the cattle by death on the voyage. This adverse result seems to have been due to bad management, for two successful voyages from the River Platte, in South America, have been made to England, with live cattle and horses. The trips occupied twenty-four days, and nearly one hundred head were taken at each trip, arriving in London in such fine condition, that they sold immediately to farmers, for feeders, at a profit of one hundred per cent above cost.

“Loss of Cud.”—“F. P.,” Anderson Co., Texas. This is an ambiguous term. It may mean dropping of the cud from the mouth, during rumination, or a suspension of rumination. Both may occur from the same cause, viz., indigestion, or eating injurious or poisonous plants. If this is the cause, the stomach and bowels should be cleared by a strong purgative, such as twelve ounces of Epsom salts, with one ounce of ground ginger along with it. But the latter may occur from the animal having swallowed something, which has injured the paunch, such as a thorn, a nail, piece of glass, or other rough, sharp substance. The symptoms which might be looked for in this case, would be a rapid wasting and weakness, a staring coat, and a dull-colored skin, with much loose scurf upon it, irregular appetite and bowels, with discharge of gas from the throat, and accumulations of it in the paunch. Nothing can be done in this case but to trust to chances, and a natural recovery, leaving the animal at rest, to facilitate a cure of the injured parts, or the expulsion of the intruding substance, if that is possible.

Packing Butter.—“S. J. T.,” Susquehanna Co., Pa. It would hardly be safe to pack butter in glass, for shipment to a distance. It is hopeless for those distant from the city markets, to compete for the fancy butter trade, in which appearance goes for a good deal. But if the butter is extra good, and is packed in new tubs or pails, it will always sell at the top of the market, wherever it may come from, as soon as it gets known.

Twins.—“C. R. D.,” Brookline, Mass. It is only occasionally that a twin heifer or bull fails to breed, and the fact that this happens, although very seldom, should not be considered as evidence of the infertility of these animals, until it is proved. We would not, therefore, turn a promising heifer calf into veal, because she was a twin with a bull calf. The term, “free marten,” sometimes used to designate such an animal, is a meaningless term, and the idea that it is necessarily a hermaphrodite, or sexless animal, is an absurdity. A pair of twin Shorthorn heifers recently sold for \$11,000, and from a pair of twin heifers a family of excellent Short-horns has been raised in England.

Sand for a Cranberry Marsh.—“T. P.,” Huron Co., Mich. The purpose for which sand is used to cover the surface of a cranberry marsh, is to prevent the growth of weeds until the cranberry-plants can get possession of the surface. Loam would not answer this purpose, and it would be worse than useless, because it would foster weeds. Only clean sand from a river bed or a bank should be used, and should be so free from clay as not to cohere when pressed in the hand.

Forest Fires.—“W. W. S.,” Green Co., Wis. The danger from fire to fences and farms, may be greatly avoided by keeping the fence rows free from weeds and in grass. The grass should be mown every year for hay. A strip outside of the fence, of at least six feet wide, should be also kept in grass, and when fires are running, and danger is apprehended, a few furrows should be run with a plow outside of this grass strip. The too common practice of building the fence in the midst of the rubbish of the clearing, or upon the very verge of the uncleared ground, is a dangerous one, and should be avoided.

Blood Diseases in Stock.—Years ago, deadly epidemics, which carried off thousands of the inhabitants of large cities, and which frequently penetrated into rural districts, with disastrous effects, were common. These were considered as mysterious visita-

tions of Providence, and calamities which were unavoidable. But their true nature came to be understood in time, and it was found that these fearful diseases were inevitable results of a transgression of natural laws, and a want of simple sanitary precautions. Exactly the same occurs now, every season, with our stock. Cholera, amongst hogs, is a typhoid disease, originating from a poisoned condition of the blood; and while it is incurable, it is entirely preventible, by the use of common precautions; so the Texan, or Spanish fever, in cattle, black-leg in young stock, rot in sheep, and all the various so-called murrains, which devastate the herd, as well as spinal meningitis, and the epizootic amongst horses, are preventible; and if the same care is taken amongst stock, as amongst ourselves, to feed well and judiciously, to use only pure water, to ventilate and keep clean the stables, and to watch the first approach of disease, little would be heard of these destructive diseases.

Bankrupt Farmers.—It rarely happens that a farmer, who minds his business, and refrains from speculations, can become a bankrupt, and then only through some unfortunate neglect, mistakes, or accidents, that in general are avoidable. But at the present time, some of those farmers who have gone into tobacco growing, and have stored their crops for higher prices, for two or three years past, and have borrowed money to carry over their stock of leaf, are in the disgraceful position of bankrupts. Their property will now be sacrificed by their creditors. This is surely a lesson to be heeded. We have taken pains to advise our readers to observe caution, with regard to this tempting crop, both early this season and last, and our caution has been widely copied by other papers. Farmers can not be too careful about growing special crops, or holding for a rise, which may never come.

Death among Horticulturists.—By some accident, we omitted at the proper time, to notice the decease of two persons well known to the horticultural public—Robert Morris Copeland and Mark Miller. Mr. Copeland was an occasional contributor to the *Agriculturist*, and was best known by his work, entitled “Country Life,” which is a very full compendium of rural affairs. He was, by profession, a landscape gardener, in which, especially in New England, he was highly appreciated. He died at Cambridge, Mass., April 10th last. . . . Mr. Miller, whom we met at the meeting of the American Pomological Society at Boston, in September last, in a very feeble condition, never recovered from the illness by which he was then nearly prostrated. He was highly esteemed at the West, as a sterling pomologist, and was for many years engaged in promoting the interests of fruit growers. He established the “Wiscousin Farmer,” and, after removing to Iowa, the “Western Pomologist,” which journal afterwards became the “Pomologist and Gardener,” and was ultimately united with the “Horticulturist” of New York. After the consolidation of the two journals, Mr. Miller remained editorially associated with the *Horticulturist*.

Curtailling Crops.—“Subscriber.” The idea that farmers can ever restrict production so as to control the prices of their crops, may as well be abandoned at once as impracticable. Farmers can not even raise exactly what they want each year, because the ground must be cultivated, or it is worse than useless, and the necessity for raising precisely such and such crops is absolute. A farm is different from a stone-quarry or a mill, which may lie idle without injury. A farm must go on, and it is only seldom that a farmer has a choice of what he may raise. But he may very readily so provide that his crops, instead of coming upon the market in a crude state, should be fed to stock, and thus be turned into a shape in which they might increase, as by compound interest, or may be made more salable.

Cheat or Chess Once More.—“Farmer,” Stamford, Ky., writes: “We want an expression from you in reference to the production of ‘cheat,’ (1) Is it a species of grass? (2) or what causes it to spring up in wheat fields or meadows? (3) If a stalk of wheat is bitten off below the point, cheat will branch out from the root. (4) In places in wheat fields where water stands any length of time after a rain, cheat is found in abundance. (5)”—(1) In former years, we have discussed this subject in full, but are ready to renew it when assertions are accompanied by proofs. (2) Yes. (3) We have no reason to believe that cheat, or chess, is produced in any manner different from other plants—i. e., from seeds. (4) This is a statement that has been frequently made; let us have the specimens. We will willingly pay the expenses on a box containing plants, known and proven to be wheat which bear cheat or chess. (5) In wet places, wheat or its seed is killed, while the cheat survives. Our correspondent should read the report of a committee of the New York State Agricultural

Society, published several years ago, and he will see that all the various methods to cause wheat to turn to chess were thoroughly tested. Ten or more years ago, Mr Judd offered a large premium for a specimen which should be pronounced by competent botanists to be part wheat and part chess. The offer remained open for several years, but no specimens were presented.

Diarrhoea in a Colt.—A “Subscriber,” Lancaster Co., Pa. In case a sucking colt suffers from diarrhoea, we would give the mare cold rice water for drink, made by boiling four ounces of rice in a gallon of water. This should be mixed, when cold, with her usual drink. One ounce of prepared chalk and one of salt should also be given in each feed for a few days, until the diarrhoea in the colt is stopped. It is probably due to acidity of the mother’s milk, which may be caused by overwork or indigestion, or from indigestion in the colt. Some chalk should also be placed where the colt can lick it. The above remedy is also effective when young calves are similarly troubled.

“Esquire.”—“E. N. N.” is in trouble, because we and others address him as “Esquire,” and thinks it no more proper than to call him “Rev.” “Doct.,” etc., and asks our views on it. We have no views on the subject whatever, but have found that the world runs much easier if we fall in with its harmless usages, than to try to reform them. It is very absurd to say to a man, “How do you do?” when we do not care a snap how he does. Yet it is a part of the grease that keeps our social machinery in order.

Foreign Imports and Native Exports.—The Bureau of Statistics furnish the following very gratifying figures, showing the exports and imports of merchandise for seven months, ending January, 1874, as compared with those for the same period in 1873, viz:

Periods.	Imports.	Dom’c exp’ts.	Foreign Specie val. exports.
7 months ended Jan. 31, 1873.	379,190,969	329,906,257	15,970,837
7 months ended Jan. 31, 1874.	329,496,105	360,837,772	12,857,469

This shows a remarkable change in the course of trade, being a balance in our favor of over \$44,000,000 the present year, in place of a balance against us of nearly \$24,000,000 last year, or a difference altogether of over \$78,000,000.

Rape and Vetches, or Tares.—“R. D. W.,” Washington, Pa. Rape (*Brassica napus*) is a plant nearly allied to the turnip, but has not an edible root. It is grown for its stalk and leaves, which make a fine fall, or winter, pasture for sheep. The crop may be sown in July, or August, upon an oat stubble, broadcast, at the rate of a peck of seed per acre, and may be pastured from November until covered too deeply with snow. Sheep will gather a good deal of it by pawing away the snow, if not too deep, through the winter, and the green feed and the exercise are excellent for them. The refuse of the crop may be plowed under in the spring. Tares (*Vicia sativa*) are a leguminous plant, not unlike peas. They may be sown in spring, or fall, (there being two varieties, as in wheat), and cut for green fodder, or for soiling during the summer. 2½ to 3 bushels of seed per acre are generally sown. Either of these requires rich soil for successful culture. Tares are excellent green fodder for horses.

Disease of the Lungs.—“J. McD.,” Perry Co., Ohio. Amongst highly bred animals a disease known as emphysema, or the presence of air in the cellular tissue of the lungs, is more frequent than in other stock. Hereditary taint and high feeding are generally the causes. Difficult respiration and discharge, mixed with blood from the nostrils, generally accompany the disease, as do also an irregular condition of the bowels, falling off in flesh, staring coat, and poor appetite. The presence of the air in the tissue of the lungs enlarges their bulk and destroys their elasticity, and thus interferes with respiration and the circulation of the blood. There is no remedy, and the only means of palliation is to feed sparingly, but frequently, with the most nutritious food, to keep the animal still and in the most comfortable condition, to card daily with the wire card, which will assist circulation, and to give tonics, such as half a dram of sulphate of copper, with a tea-spoonful of ginger daily, in the feed.

The Value of Chandler’s Scraps.—“J. H. B.,” Westchester, Pa. The refuse of tallow or lard renderers is worth more for feed than for manure. The fat it contains is valuable when fed, but useless as a fertilizer. It is better, therefore, to feed the scraps, because then nearly all the nitrogen they contain will be found in the manure. These scraps are worth about 1½ cent a pound.

CRANDALL'S GREAT SHOW.—THE ACROBATS.

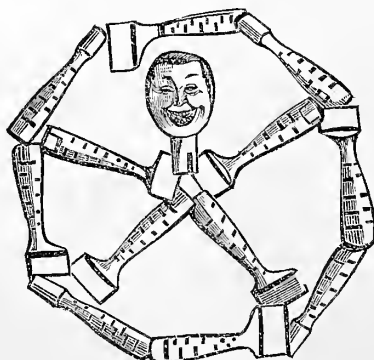
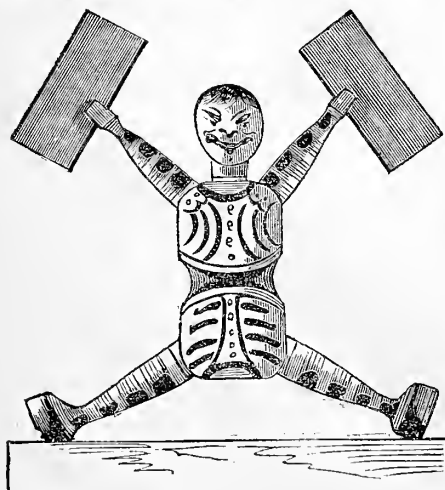
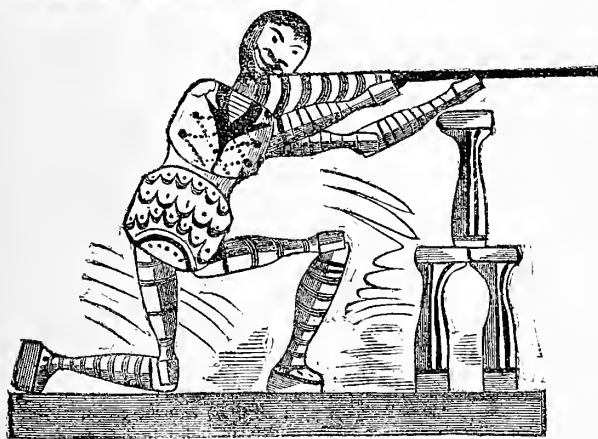
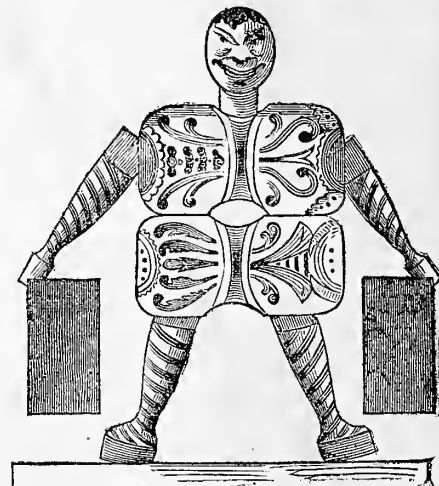
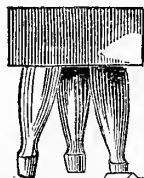
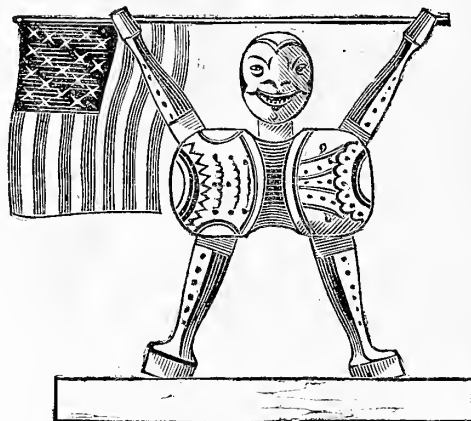
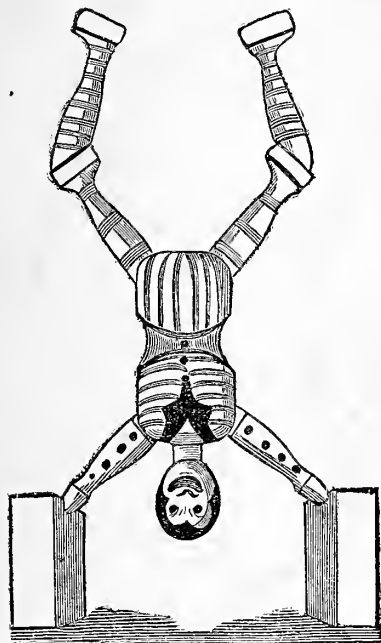

CRANDALL'S GREAT SHOW.—THE ACROBATS.

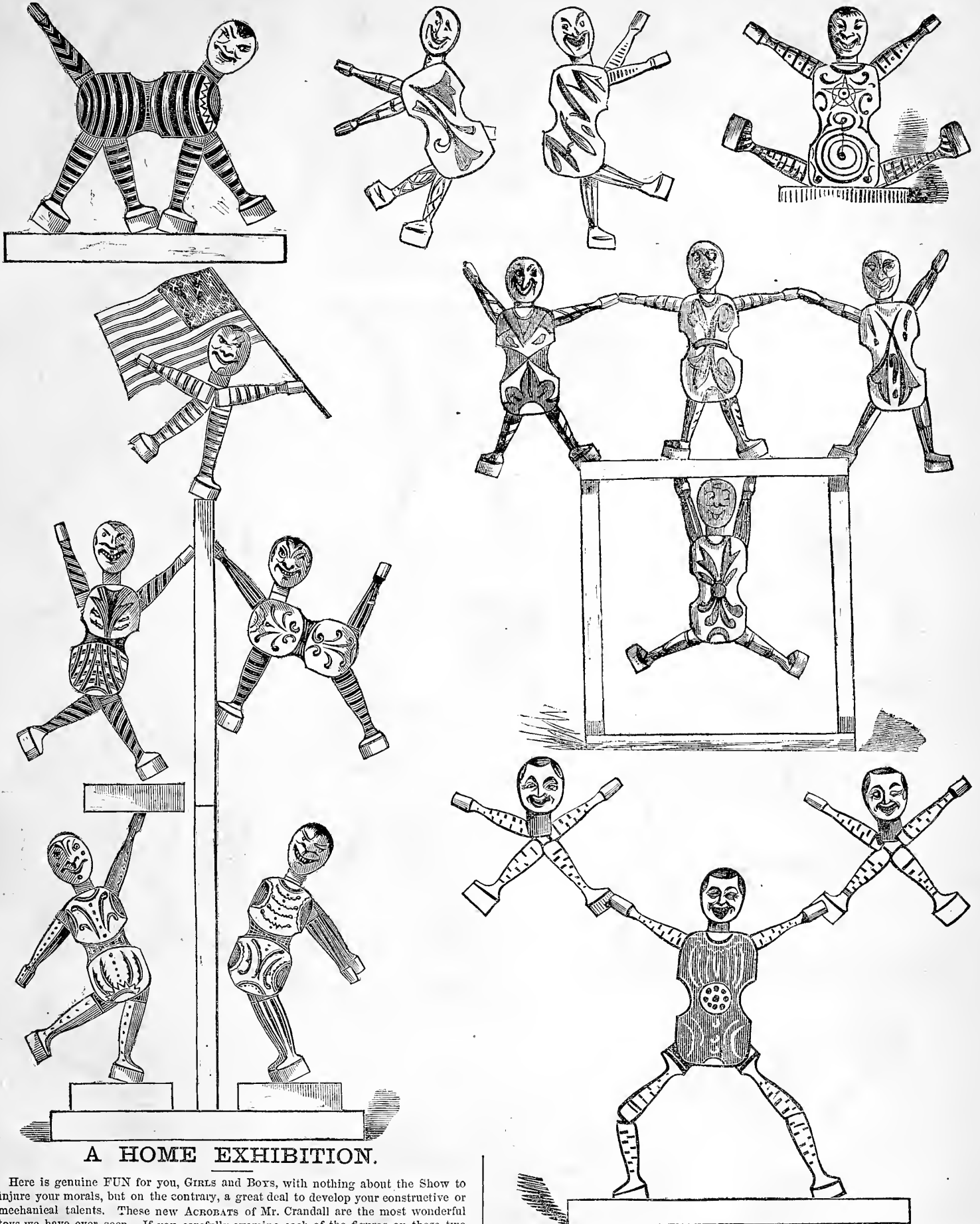

A HOME EXHIBITION.

Here is genuine FUN for you, GIRLS and BOYS, with nothing about the Show to injure your morals, but on the contrary, a great deal to develop your constructive or mechanical talents. These new ACROBATS of Mr. Crandall are the most wonderful toys we have ever seen. If you carefully examine each of the figures on these two pages, you will see that there are ONLY SEVEN different pieces. A box of these ACROBATS contains four bodies, four heads, eight arms, eight legs, one flag, and six pieces of wood, or thirty-one pieces in all, and yet from these few elements you can not only make pictures similar to those before you, but many thousands of others. The pieces are variously colored, which can not be shown in our ink engravings. They are so grooved and jointed and fitted, that they fasten strongly together in all conceivable positions. There is just one unpleasant thing about these ACROBATS, viz., everybody that has seen them wants them, and Mr. Crandall can not begin to make them as fast

as they are wanted, and it may be some time before all our boys and girls can have them. These amusing new toys are creating a furore among all the children (and old folks too) who have succeeded in getting hold of them. Every day's supply received at 245 Broadway, has "gone off like hot cakes," and correspondents are inquiring for them, their price, etc. When the market can be supplied they will be on sale by the toy dealers generally. The Orange Judd Company are selling them as fast as received at \$1 a box, delivered at 245 Broadway, New York, but if to be sent anywhere out of the city, the cost of carriage by express or otherwise must be added to the \$1 a box.



PRAIRIE, EIGHT MILES EAST FROM LINCOLN, NEB.

A representation of crops and cattle, without fences, under the Herd-law of Nebraska.

13

**IF YOU WANT A FARM OR HOME,
YOU SHOULD BUY OF THE
BURLINGTON AND MISSOURI RIVER RAILROAD CO.
IN IOWA OR NEBRASKA.**

- BECAUSE**—Their prices are low, ranging for the best land from Three to Ten Dollars per acre.
- BECAUSE**—No payments are required of the purchaser for four years, except interest at six per cent.
- BECAUSE**—After the fourth year only one seventh of the principal is payable annually till the whole is paid.
- BECAUSE**—You are not required to go into a wilderness, these being well-settled States, the population of which is rapidly increasing.
- BECAUSE**—The mildness of the climate and fertility of the soil is such that the settler can pay for his farm from the products raised upon it long before the time when the principal becomes due.

- BECAUSE**—Failure of crops from drouth is unknown.
- BECAUSE**—Large allowances are made upon fare and freight, thus giving low rates on both to purchasers of this Company's lands.

AND YOU SHOULD BUY THIS YEAR.

- BECAUSE**—Purchasers of our lands in Nebraska during 1874 who cultivate one-half their land within two years from their purchase are allowed a reduction of twenty per cent on its price.

Send for Circulars, with full information on all points, to

GEO. S. HARRIS, Land Commissioner,
At Lincoln, Nebraska, for land in Nebraska. At Burlington, Iowa for land in Iowa.
JAS. R. WOOD, General Agent, 59 Clark St., Chicago, Ill.

Or to **W. D. COWLES**, General Agent, 317 Broadway, New York.

Lake Superior and Mississippi R.R.
SAINT PAUL, June, 1874.

This Company has for sale large tracts of Land, in the vicinity of its Railroad, on which are extensive wild Cranberry Marshes, from which several Thousand Bushels were gathered in 1873. To any person acquainted with the culture of Cranberries, rare opportunities are offered. Address

JNO. P. ILSLEY,
PRESIDENT AND LAND COMMISSIONER.

CHEAP FARMS!—Fine salt water locations. Good bargains! Send for pamphlet. J. F. MANCHA, Easton, Md.

SAVE FIFTY DOLLARS!

THE NEW FLORENCE.

PRICE, \$20 below } any other first-class
VALUE, \$30 above } Sewing Machine.

SAVED, \$50 by buying the Florence.

Every machine warranted.
Special terms to clubs and dealers.
Send for circulars to the
Florence S. M. Co., Florence, Mass.,
or 39 Union Square, New York.

\$200 A MONTH TO AGENTS
to sell the IMPROVED "HOME SHUTTLE" SEWING MACHINE, a practical, low-priced "Lock Stitch" Sewing Machine. Address **JOHNSON, CLARK & CO.**, Boston, Mass.; New York City; Pittsburgh, Pa.; Chicago, Ill.; Louisville, Ky.; or St. Louis, Mo.

CLAVERRACK College and Hudson River Inst., at Claverack, N. Y. 20 instructors. **ALONZO FLACK**, Ph. D., Pres.

Samples from
B. E. Hale & Co.,
56 and 58 Park
Place, N. Y.
Sole Agents for
Eastern States.

BUILDING PAPER!
FOR SHEATHING, ROOFING, DEAFENING, CARPET LINING, AND PLASTERING!

Rock River Paper Company, Chicago, Ill.

EVERY LADY SHOULD HAVE A SET OF
GOODRICH'S "SPRING" TEMPERED HEMMERS
Consisting of Four Widths and a Dress Binder. Sent by Mail on Receipt of Price.
For Sale by all Sewing Machine Agents. } 205 State Street, CHICAGO, ILL.
Price, Only One Dollar. } **H. C. GOODRICH**, 103 N. 10th St., PHILADELPHIA, PA.
Inventor of The Goodrich Tuck Marker.

L. A. Gillett
STEEL PENS!
Sold by all Dealers.
No. 91 JOHN ST., NEW YORK.
HENRY HOE, Sole Agent. **JOSEPH GILLOTT & SONS.**

THE PENN MUTUAL LIFE INSURANCE COMPANY OF PHILADELPHIA.
ASSETS ACCUMULATED, \$4,427,996.96.
The Penn is a purely mutual Company. All of its surplus premiums are returned to the members every year. Dividends may be applied to reduce the premium or increase insurance as desired. **SAM'L C. HUEY**, Pres.
General and Local Agents wanted in the Middle and Western States. Apply to **H. S. STEPHENS**, Vice Pres., No. 921 Chestnut Street, Philadelphia, Pa.

NIAGARA FIRE INSURANCE COMPANY,
201 Broadway, N.Y.
Capital Stock.....\$500,000
Cash value of Assets.....\$1,908,224
Total Liabilities.....\$2,302

Net Assets.....\$1,225,922
Dwellings and Farm Risks a specialty at all our Agencies.
HENRY A. HOWE, President.
P. NOTMAN, V. P. and Sec'y.

\$100 to \$200 per month guaranteed to agents everywhere, to sell our **Indestructible White Wire Clothes Lines**. Sample free. Address the **Hudson Wire Mills**, 133 Maiden Lane, N. Y., or 18 Clark St., Chicago, Ill.

HOW TO MAKE MONEY AT HOME. 60 pp. Book free. **J. JAY GOULD**, Boston, Mass.

ADVERTISERS should send to **Geo. P. Rowell & Co.**, 41 Park Row, N. Y., for their **Eighty-page Pamphlet**, containing lists of 3,000 newspapers and estimates, showing the cost of advertising. Mailed free to all applicants.

STANDARD WORKS ON
HORSES.

Sent post-paid on receipt of price.

- Cole, S. W.** The American Veterinarian. 18mo. \$ 75
- Dadd, Geo. H.** The Modern Horse-Doctor; containing Practical Observations on the Causes, Nature, and Treatment of Disease and Lameness in Horses. 12mo. 1 50
- De Huys, Chas.** The Percheron Horse. 12mo. Illustrated. 1 00
- Dwyer, Francis.** On Seats and Saddles, Bits and Bitting, and the Prevention and Cure of Restiveness in Horses. 12mo. Illustrated. 2 00
- Frank Forester's Horse and Horsemanship** of the United States and British Provinces of North America. By Henry William Herbert. In two superb royal octavo volumes of 1,200 pages, with steel engraved original portraits of thirty celebrated representative Horses. This Standard Historical Work has been thoroughly revised, newly written, compiled, and perfected to the present time. By S. D. & B. G. Bruce, Editors of the *Turf, Field, and Farm*. Price, post-paid. 10 00
- Herbert, H. W. (Frank Forester).** Hints to Horse-Keepers. A Complete Manual for Horsemen; embracing how to Breed, Buy, Break, Use, Feed, Physic Horses, etc. Illustrated. 12mo. 1 75
- Jennings, R.** Horse-Training made Easy. Being a New and Practical System of Teaching and Educating the Horse. 16mo. 1 25
- Jennings, R.** The Horse and his Diseases; embracing his History and Varieties, Breeding, etc. Illustrated. 12mo. 1 75
- McClure, R.** The Gentleman's Stable Guide. Familiar Descriptions of the Am. Stable; most approved Method of Feeding, Grooming, and General Management of Horses. 12mo. 1 50
- Mayhew, E.** The Illustrated Horse Management. Descriptive Remarks on Anatomy, Medicine, Shoeing, Food, etc. Illustrated. 8vo 3 00
- Mayhew, E.** The Illustrated Horse Doctor. Being an Accurate and Detailed Account, accompanied by more than 400 Pictorial Representations, of the various Diseases to which the Horse is subject. 8vo. 3 00
- Miles on the Horse's Foot.** 75
- Murray, Rev. W. H. H.** The Perfect Horse. 4 00
- Rational Horse-Shoeing.** 1 00
- Riley, H.** The Mule. A Treatise on the Breeding, Training, and Uses to which he may be put. 12mo. Cloth. 1 50
- Simpson, J. C.** Horse Portraiture; embracing Breeding, Rearing, and Training Trotters, their Management on Track, Preparation for Races, etc., etc. With an Appendix containing the performances of Dexter, and a Portrait. 3 00
- Stewart, John.** The Stable Book. A Treatise on Management of Horses, in relation to Stabling, Feeding, Grooming, Watering, and Working; Construction of Stables, etc., etc. 12mo. Illustrated. 1 50
- Stonehenge on the Horse in the Stable and the Field.** By J. H. Walsh (Stonehenge). Illustrated. 170 engravings. 8vo. Cloth. 3 50
- Veterinary Homeopathic Practice.** 5 00
- Wallace, J. H.** American Stud-Book. Vol. I. Being a Compilation of the Pedigrees of American and Imported Blood-Horses to 1840. 10 00
- Wallace, J. H.** American Trotting Register. Containing Pedigrees of Trotting Horses, and a Record of all Performances, from the earliest dates to the close of 1870; being over 6,000 contests. With Essay on True Origin of the American Trotter, and Rules of Government for trials of speed. 10 00
- Walsh, J. H. (Stonehenge).** The Horse in the Stable and the Field, and Management in Health and Disease; with Essay on the American Trotting Horse; Suggestions on Breeding and Training of Trotters. Large 12mo. Illustrated. 2 50
- Warne's Handbook on the Horse; Varieties and Management.** 50
- Woodruff, Hiram.** The Trotting Horse of America. How to Train and Drive Him. 12mo. Cloth. 2 25
- Youatt, W.** On the Structure and Diseases of the Horse, with their Remedies. Brought down by W. C. Spooner. 12mo. 1 50

Address: ORANGE JUDD COMPANY, 245 BROADWAY, NEW YORK.

STANDARD WORKS ON
Cattle, Sheep, and the Dog.

Sent post-paid on receipt of price.

- Allen, R. L.** Domestic Animals. History and Description of the Horse, Mule, Cattle, Sheep, Swine, Poultry, and Farm Dogs. With Directions for their Management, Breeding, etc. 12mo. \$1 00
- Allen, L. F.** American Cattle. Their History, Breeding, and Management. Illustrated. 12mo. 2 50
- Dadd, J. H.** The American Cattle Doctor. Containing the Necessary Information for Curing the Diseases of Oxen, Cows, Sheep, etc. 12mo. 1 50
- Darwin, Charles.** The Variation of Animals and Plants under Domestication. Illustrated. 2 vols. 12mo. 6 60
- Flint, Chas. L.** Milch Cows and Dairy Farming. 2 50
- Guenon, M. F.** A Treatise on Milch Cows, whereby the Quality and Quantity of Milk any Cow will give may be accurately determined by observing natural marks and external indications alone, etc. 8vo. Cloth. 75
- Harris, Joseph.** A Treatise on the Pig. Breeding, Rearing, Management, and Improvement. Illustrated. 1 50
- Jacques.** The Barn-Yard. A Manual of Cattle, Horse, and Sheep Husbandry; or, How to Breed and Rear Domesticated Animals. 12mo. 1 00
- Jennings, R.** Sheep, Swine, and Poultry. The best Modes of Breeding, their Feeding, Management, etc. Illustrated. 12mo. Cloth. 1 75
- Jennings, R.** Cattle and their Diseases. Embracing their History and Breeds, Crossing and Breeding, Feeding and Management. 1 75
- Morrell, L. A.** The American Shepherd. Being a History of the Sheep; with their Breeds, Management, and Diseases. 12mo. 1 75
- Randall, H. S.** Fine Wool Sheep Husbandry. 12mo. 1 00
- Randall, H. S.** Sheep Husbandry. With an Account of the Different Breeds, and Directions in regard to Summer and Winter Management. 1 50
- Randall, H. S.** The Practical Shepherd. A Complete Treatise on the Breeding, Management, and Diseases of Sheep. 8vo. 2 00
- Youatt, W., and W. C. L. Martin.** Cattle. Being a Treatise on their Breeds, Management, and Diseases. Illustrated. 12mo. 1 50
- Youatt, W., and W. C. L. Martin.** The Dog. A Treatise on the Breeds, Management, Feeding, and Medical Treatment of Swine, etc. 1 00
- Youatt, W.** Sheep. Their Breeds, Management, and Diseases. To which are added Remarks on the Management of Sheep in the United States. 1 00
- Herbert, H. W. (Frank Forester).** The Dog. By Dinks, Mayhew, and Hutchinson. Compiled, Edited, and Illustrated by Frank Forester. 3 00
- Richardson, H. D.** Dogs. Their Origin and Varieties; Directions as to their Management, etc. 12mo. Cloth. 60
- Stonehenge on the Dog.** 3 75
- Warne's Handbook on Cattle; Varieties and Management.** 50
- Warne's Handbook on Sheep; Varieties and Management.** 50
- Willard, X. A.** Dairy Husbandry. 3 00
- Youatt, William.** The Dog. Illustrations. 8vo. Cloth. 4 00

*Address

ORANGE JUDD COMPANY, 245 BROADWAY, NEW YORK.

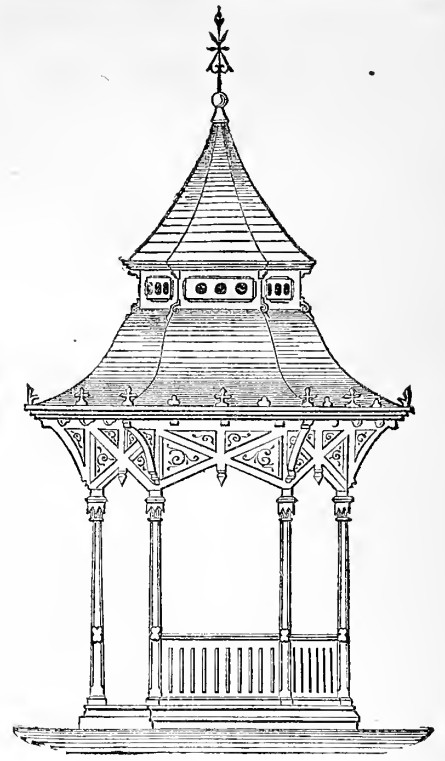

A Practical Book, one that Architects, Builders, and Carpenters can not afford to be without, entitled

DETAIL, COTTAGE, AND CONSTRUCTIVE
ARCHITECTURE,

Containing 76 FULL PLATES, 20 plates more than before offered in a similar work for Ten Dollars.

Published under the direction of A. J. BICKNELL.

Showing a great variety of Designs for Cornices, Brackets, Windows and Window Caps, Doors, Piazzas, Porches, Bay and Dormer Windows, Observatories, Towers, Chimney Tops, Balconies, Canopies, Scrolls, Gable and Sawed Ornaments, Fences, Stairs, Newels, Archedrives, Mantels, Plaster Finish, etc., etc., including Forty-five Perspectives, Elevations and Plans of Modern Designs for Cottages with Details, and Eighteen Elevations of Summer Houses, Villas, Seaside Cottages, and Country Houses, together with Fourteen Designs for Street and Store Fronts, with Inside Finish for Stores and Banks; also, Framing for Dwellings, Barns, Exhibition Buildings, Roofs, Bridges, etc., etc., making in all a Practical Book for Architects, Builders, Carpenters, and all who contemplate Building or Remodeling Wood, Stone, or Brick Buildings. One Large Quarto Volume, sent Free by Mail or Express, on receipt of Price. \$10.00.

CARPENTERS' and BUILDERS' ASSISTANT,

And Wood Workers' Guide,

By L. D. GOULD, Architect and Practical Builder.

Containing 23 Plates, fully described; also, tables of the strength of materials; technical terms used by carpenters, etc., etc. This work is intended to combine all the knowledge the workman requires to construct any design in carpentry, by a new and easy system of lines, reducing the science of construction to an agreeable and pleasant occupation, rather than an unpleasant task. One 8vo. volume, bound in cloth. Price. \$3.00.

ARCHITECTURE.

By CUMMINGS & MILLER.

A Practical Book on Architectural Details; containing over One Thousand Designs and Illustrations, showing the manner of constructing Cornices, Doorways, Porches, Windows, Verandas, Railings, French Roofs, Observatories, Piazzas, Bay-Windows, Cast-Stone Work, various styles of Modern Finish, and Street Fronts of Houses, Stores, etc., etc. One Large Quarto Volume. Price, post-paid. \$10.00.

Loth's Practical Stair-BUILDER.

A complete Treatise on the Art of Building Stairs and Hand-Rails. Designed for Carpenters, Builders, and Stair-Builders. Illustrated with Thirty Original Plates. By C. EDWARD LOTH, Professional Stair-BUILDER. One large Quarto Volume. Bound in Cloth. Price. \$10.00.

Address

ORANGE JUDD COMPANY, 245 BROADWAY, NEW YORK.

Standard Architectural Books for Carpenters and Builders.



Hussey's National Cottage Architecture; or, Homes for Every One.—With Designs, Plans, Details, Specifications, and Cost; with Working Scale, Drawings complete, so that Houses may be built direct from the book. Adapted to the popular demand for practical, handsome, and economical homes. Royal Quarto. Six Dollars, post-paid.

Atwood's Country and Suburban Houses.—Illustrated with about 150 engravings. Hints and Suggestions as to the General Principles of House-building, Style, Cost, Location, etc. Post-paid, \$1.50.

Monckton's National Stair-Builder.—Is a complete work on Stair-Building and Hand-Railing. Fully explained and illustrated by large scale diagrams, in two colors, with designs for Staircases, Newels, Balusters, and Hand-Rails. Royal Quarto. Post-paid, \$6.00.

Monckton's National Carpenter and Joiner.—A complete work, covering the whole science of Carpentry, Joinery, Roofing, Framing, etc., fully explained and illustrated by large scale diagrams in two colors. Royal Quarto. Postpaid, \$6.00.



Woodward's National Architect.—1,000 Designs, Plans, and Details for Country, Suburban, and Village Houses; with Perspective Views, Front and Side Elevations, Sections, Full Detail Drawings, Specifications, and Estimates. Also, Detail Drawings to Working Scale, of Brackets, Cornices, French Roofs, Sectional and Framing Plans of French Roofs, Dormer-Windows for French Roofs, Bay-Windows, Verandas, Porches, Plaster Finish, Cornices, Ceilings, Hard-wood Mantels, and all that is required by a Builder to design, specify, erect, and finish in the most approved style. One superb quarto volume. Post-paid, \$12.00

ORANGE JUDD COMPANY, Publishers, 245 Broadway, New York.

Woodward's Cottages and Farm Houses.—188 Designs and Plans of low-priced Cottages, Farm Houses, and Out-Buildings. Post-paid, \$1.50.

Woodward's Suburban and Country Houses.—70 Designs and Plans, and numerous examples of the French Roof. Post-paid, \$1.50.



Woodward's Country Homes.—150 Designs and Plans, with Description of the Method of Constructing Balloon Frames. Post-paid, \$1.50.

Woodward's Graperies and Horticultural Buildings.—Designs and Plans of Hot-Beds, Cold-Pits, Propagating Houses, Forcing Houses, Hot and Cold Graperies, Green Houses, Conservatories, Orchard Houses, etc., with the various modes of Ventilating and Heating. Post-paid, \$1.50.

Wheeler's Rural Homes.—Houses suited to Country Life. Post-paid, \$2.00.

Wheeler's Homes for the People.—100 Original Designs, with full Descriptions, and Constructive and Miscellaneous Details. Post-paid, \$3.00.

Harney's Barns, Out-Buildings, and Fences.—Containing Designs and Plans of Stables, Farm-Barns, Out-Buildings, Gates, Gateways, Fences, Stable Fittings and Furniture, with nearly 200 Illustrations. Royal quarto. Post-paid, \$6.00.

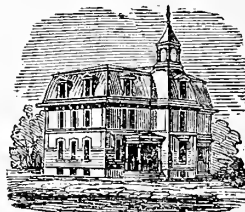

Eveleth's School-house Architecture.—A new and original work, containing Seventeen Designs for School-houses, Sixty-seven Plates with Perspectives, Elevations, Plans, Sections, Details, Specifications all drawn to working scale, with methods of Heating and Ventilation. Large quarto. Post-paid, \$6.00.

Copley's Plain and Ornamental Alphabets.—Giving examples in all styles, together with Maps, Titles, Borders, Meridians, Ciphers, Monograms, Flourishes, etc., adapted for the practical use of Surveyors, Civil Engineers, Draughtsmen, Architects, Sign Painters, Schools, etc. Post-paid, \$3.00.

CUMMINGS' Architectural Details.

CONTAINING

387 Designs and 967 Illustrations

Of the Various Parts Needed in the Construction of Buildings, Public and Private, both for the City and Country.

ALSO, PLANS AND ELEVATIONS OF Houses, Stores, Cottages, and Other Buildings.

BY M. F. CUMMINGS, A.M., Architect, Associate Author of "Architecture, by Cummings & Miller," and "Modern American Architecture, by Cummings & Miller."

Nearly eight years ago, the author of this work, in connection with Mr. C. C. Miller, architect, published a work on architectural details, which, as soon as it was presented to the architects, carpenters, and builders of the country, met with a rapid sale; and, judging from the number of editions through which it has passed, and the great circulation reached, it must have met the approval of those most interested in practical architectural works, and must have filled, in a measure, a want before unsupplied.

The success of that book has induced the author to publish a second one, which is now presented to the public, and in it will be found an extensive collection of designs illustrating the features which go to make up structures such as are needed to meet the wants of the American people.

What has been aimed at is this: To present a mass of architectural details, easy of construction, pleasing in form, and generally of an inexpensive character, and all so designed that a great variety of selections may be made from them, which, when combined in a building, will produce a harmonious whole; and it is believed by the author that this work will be found to be of value, and that its design is practicable, for there are hundreds of towns and villages, in all the States of the Union, in which the wants of the people continually demand the erection of buildings, largely of wood, and which in the hands of the builder and workman may be made elegant and pleasing in all their features, provided they have at hand a guide such as this book is intended to be.

Royal Quarto. Price, post-paid, \$10.

ORANGE JUDD COMPANY, 245 BROADWAY, NEW YORK.

PEAR CULTURE

FOR PROFIT.

By P. T. QUINN,

PRACTICAL HORTICULTURIST.

ILLUSTRATED.

Contents:

Chap. I. Varieties.	Chap. IX. Varieties to Plant.
" II. Aspect.	" X. Pruning.
" III. Preparation of the Soil.	" XI. Manuring and Mulehng.
" IV. Distance Apart in Planting.	" XII. Gathering Fruit.
" V. Dwarfs and Standards.	" XIII. Marketing Pears.
" VI. Planting-Time.	" XIV. Profits.
" VII. Planting.	" XV. Propagation, etc.
" VIII. Nursery Trees.	" XVI. Practical Suggestions.
	" XVII. Orchard Record.

PRICE, POST-PAID.....\$1.00

ORANGE JUDD COMPANY, 245 BROADWAY, NEW YORK.

Newly Revised and Enlarged Edition.

Practical Floriculture.

A Guide to the Successful Propagation and Cultivation of Florists' Plants.

By **PETER HENDERSON,**
Author of "Gardening for Profit."

Beautifully Illustrated. Price, Post-paid, \$1.50.

In this work, which has everywhere become so deservedly popular, not only is the whole "art and mystery" of propagation explained, but the reader is taught how to plant and grow the plants after they have been propagated. The work is not one for florists and gardeners only, but the amateur's wants are constantly kept in mind, and we have a very complete treatise on the cultivation of flowers under glass, or in the open air, suited to those who grow flowers for pleasure as well as those who make them a matter of trade. The work is characterized by the same radical common sense that marked the author's "Gardening for Profit," and it holds a high place in the estimation of lovers of floriculture. The new edition has been thoroughly revised by the author, and much enlarged by the addition of valuable matter.

The following are a few of the subjects embraced in the latest edition:

Laying out Flower Garden and Lawn; Designs for Grounds and for Greenhouses; Soils for Potting; Cold Frames; Hot-Beds; Greenhouses Attached to Dwellings; Modes of Heating; Propagation of Plants by Seeds and by Cuttings; Culture of the Rose and Tuberoses; Growing of Winter-flowering Plants; Construction of Bouquets, Baskets, etc.; Parlor and Window-Gardening; Wardian-Cases and Ferneries; Insects; What Flowers Grow in the Shade; Culture of Grape-Vines under Glass; The Profits of Floriculture; How to Become a Florist, etc., etc.

THE ILLUSTRATED Book of Poultry,

With Practical Schedules for Judging, Constructed from Actual Analysis of the Best Modern Decisions.

By **LEWIS WRIGHT,**

Author of "The Practical Poultry Keeper," "The Brahma Fowl," etc.

ILLUSTRATED WITH Fifty Colored Portraits of Prize Birds,

Painted from Life by J. W. Ludlow.

CONTENTS.

- | | |
|---|--|
| CHAP. 1.—Houses and Accommodation. | CHAP. 19.—Brahmas. |
| 2.—The Selection of Stock. | 20.—Malays. |
| 3.—Feeding and General Treatment of Poultry. | 21.—Game. |
| 4.—Eggs and Incubation. | 22.—Dorkings. |
| 5.—Artificial Hatching. | 23.—Spanish. |
| 6.—The Management of Chickens. | 24.—Hamburghs. |
| 7.—Fattening and Killing. | 25.—Polish Fowls. |
| 8.—Poultry as National Food. | 26.—French Breeds of Poultry. |
| 9.—The Utility of "Fancy Points." | 27.—American Breeds of Poultry. |
| 10.—Commencing a Strain. | 28.—Unclassed Varieties of Poultry. |
| 11.—Mating Stock for Breeding Prize Birds. | 29.—Bantams (Except Game). |
| 12.—Rearing, Care, and Exhibition of Prize Poultry. | 30.—Game Bantams. |
| 13.—Shows and Judging. | 31.—Wild Breeds of Poultry, Origin of the Domestic Fowl. |
| 14.—Buying, Selling, and Exporting. | 32.—The Guinea Fowl. |
| 15.—Enemies in the Yard. | 33.—The Turkey. |
| 16.—Diseases of Poultry. | 34.—The Pea Fowl. |
| 17.—Technical Terms. | 35.—Ducks. |
| 18.—Cochins. | 36.—Geese. |
| | 37.—Swans. |
| | 38.—Possible Additions to the Poultry Yard. |

Price, Postpaid - - - - \$15 00

Either of the above books sent post-paid on receipt of price by

ORANGE JUDD COMPANY,
245 BROADWAY, NEW YORK.

SUPERIOR STANDARD WORKS.

Published by **ORANGE JUDD COMPANY.**

THE HORSE.

FRANK FORESTER'S HORSE OF AMERICA.

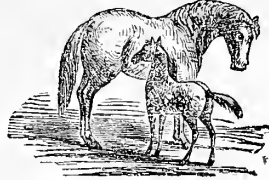

By **HENRY WM. HERBERT.**

Revised, corrected, enlarged, and continued to 1871,

By **S. D. and B. G. BRUCE.**

Always an **ACKNOWLEDGED STANDARD,** and now the most **COMPLETE and AUTHENTIC** Work on the **HORSE.** With steel-engraved portraits of Thirty of the most famous

REPRESENTATIVE HORSES,

including pedigrees, histories, and performances.

Two superb royal octavo volumes of upward of 1300 pages.

Post-Paid, Ten Dollars.



WALLACE'S

American Trotting Register.

CONTAINING ALL THAT IS KNOWN OF THE

PEDIGREES OF TROTTING HORSES,

their ancestors and descendants, with a record of

All published performances in which a mile was trotted or paced in 2.40 or less,

from the earliest dates until the close of 1868, and a full record of the performances of 1869 and 1870.

Giving complete Summaries of over 6,000 Contests.

With an **INTRODUCTORY ESSAY** on the true origin of the American Trotter. And a set of Rules for the government of all trials of speed. By **J. H. WALLACE,** compiler of Wallace's American Stud-Book. Royal octavo.

Post-paid, Ten Dollars.

WALLACE'S AMERICAN STUD-BOOK.

VOL. ONE. BEING A COMPILATION OF THE

PEDIGREES OF AMERICAN AND IMPORTED BLOOD HORSES,

from the earliest records, with an **APPENDIX** of all named animals without extended Pedigrees prior to the year 1840. And a **SUPPLEMENT,** containing a history of all Horses and Mares that have trotted in public from the earliest trotting races until the close of 1866. By **J. H. WALLACE.** Royal octavo of over 1000 pages elegantly bound in extra cloth, beveled boards, and splendidly illustrated.

Post-paid, Ten Dollars.

Horse Portraiture. — BREEDING,

REARING, AND TRAINING TROTTERS. Preparations for Races, Management in the Stable, on the Track, Horse Life, etc. By **JOSEPH CAIRN SIMPSON.** Post octavo. Post-paid, \$3.00.

FIELD SPORTS.



Frank Forester's Field Sports.

Embracing the Game of North America, Upland Shooting, Bay Shooting, Wild Sporting of the Wilderness, Forest, Prairie, and Mountain Sports, Bear Hunting, Turkey Shooting, etc. 13th edition, revised and illustrated. Two post octavo volumes. Post-paid, \$6.00.

Frank Forester's Fish and Fishing.

100 engravings. Embracing a full illustrated description of the Game Fish of North America; Trout and Salmon Fishing; Shoal Water and Deep Sea Fishing; Lake and River Fishing; Trolling. Fly Fishing, etc. 12th edition. One post octavo volume. Post-paid, \$3.50.

Frank Forester's Complete Manual.

For Young Sportsmen, of Fowling, Fishing, and Field Sports. With directions for handling the Gun, the Rifle, and the Rod. Art of Shooting on the Wing. The Breeding, Management, and Hunting of the Dog. The varieties and habits of Game. River, Lake, and Sea Fishing. Post octavo. Post-paid, \$3.00.

Frank Forester's American Game in its

SEASONS, Fully Illustrated and Described. New edition, post-paid, \$3.00.

The Dog.

By **Dinks, Mayhew & Hutchinson.** Compiled and edited by **Frank Forester.** Contains full instructions in all that relates to the Breeding, Rearing, Breaking, Kenneling, and Conditioning of Dogs, with valuable recipes for the treatment of all diseases. Illustrated. Post octavo. Post-paid, \$3.00.

The Dead Shot:

Or, Sportsman's Complete Guide; a Treatise on the use of the Gun, with Rudimentary and Finishing Lessons in the Art of Shooting Game of all kinds. By **Marksman.** Post-paid, \$1.75.

The Crack Shot:

Or, Young Rifleman's Complete Guide; being a Treatise on the use of the Rifle, with Lessons, including a full description of the latest improved breech-loading weapons; rules and regulations for Target Practice, and directions for Hunting Game. By **Edward C. Barber.** Post-paid, \$1.75.

Gun, Rod, and Saddle.

Nearly fifty practical articles on subjects connected with Fishing, Shooting, Racing, Trotting, etc. Post-paid, \$1.

Practical Trout Culture.

By **J. H. Slack, M. D.,** Commissioner of Fisheries, New Jersey. Fully illustrated and describing thoroughly all that is requisite to successful Trout Culture. Post-paid, \$1.50.

AGRICULTURE.

Woodward's Graperies and Horticultural

BUILDINGS. Designs and Plans of Hot-beds, Cold Pits, Propagating Houses, Forcing Houses, Hot and Cold Graperies, Greenhouses, Conservatories, Orchard Houses, etc., with the various modes of Ventilating and Heating. Post-paid, \$1.50.

Jacques' Manual of the Garden, Farm,

AND BARN-YARD. Embracing the Cultivation of Vegetables, Fruit, Flowers, all Field Crops, Details of Farm Work and Rearing Domestic Animals. New and Revised Edition. One volume. Post-paid, \$1.75.

Young Farmer's Manual.

Vol. I. The Farm and the Workshop, with Practical Directions for laying out a Farm, Erecting Buildings, Fences, Farm Gates, selecting good Farm and Shop Tools, and performing Farm Operations. Fully Illustrated. Post-paid, \$1.75.

Young Farmer's Manual.

Vol. II. How to Make Farming Pay, with full Details of Farm Management, Character of Soils, Plowing, Management of Grass Lands, Manures, Farm Implements, Stock, Drainage, Planting, Harvesting, etc. Illustrated. Post-paid, \$1.75.

Husmann's Grapes and Wine.

The Cultivation of the Native Grape and Manufacture of American Wine. By **Geo. Husmann,** of Missouri. Post-paid, \$1.50.

Elliott's Lawn and Shade Trees.

For Planting Parks, Gardens, Cemeteries, Private Grounds, and Avenues. Fully Illustrated and described. Post-paid, \$1.50.

Fuller's Forest Tree Culturist.

The Cultivation of Forest Trees for Shade, for Shelter, for Fuel, for Timber, and for Profit. Illustrated. Post-paid, \$1.50.

ORANGE JUDD COMPANY, 245 Broadway, N. Y.

GREAT DEDUCTION. TEAS and COFFEES

At Wholesale Prices.

Increased Facilities to Club Organizers. Send for New Price-List. THE GREAT AMERICAN TEA COMPANY, (P. O. Box 5643.) 31 and 33 Vesey St., New York.

WOOD, TABER & MORSE, Eaton, Madison Co., N. Y.

MANUFACTURERS OF

Steam-Engines, Portable, Stationary, and Agricultural.

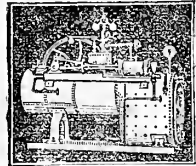

Hundreds in use in Shops, Printing Rooms, Mills, Mines, and on Farms and Plantations for Grain Threshing, Food Cooking for Stock, Cotton Ginning, Sawing, etc. Circulars sent on application.

Carbonized Enamel IS AS PURE AS GLASS.

The Bridgeport Mfg Co., OF BRIDGEPORT, CONN.

(Office, No. 88 Chambers St., New York). Have the exclusive control of this valuable enamel, and are using it to cover all of their celebrated

American Submerged Force Pumps.

They also enamel pipe inside and out, which delivers the water chemically pure. The Enamel is composed of vegetable matter, baked on so hard that a blow does not break it, and it resists acids that eat gold.

Gentlemen: I have examined the sections of Carbonized Enamel Pipe submitted to me by you. It is superior to any pipe I have ever seen for resisting acids and conducting water from springs or for use in connection with pumps, etc. The Enamel adheres with astonishing tenacity, withstanding even heavy blows; and the surface of the metal where the enamel is beaten off seems to be protected against the ordinary action of water.

M. C. WELD,

Late Associate Editor Am. Agriculturist.

MUDGE & WOODS, No. 88 Chambers St., N. Y., are the exclusive selling agents of the Bridgeport Mfg Co. for the Licenses of States, counties, and towns rights for the American Submerged Suction and Force Pumps.

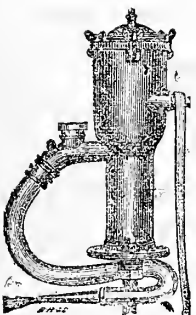

THE PEOPLE'S Force Pumps.

Awarded medal of American Institute over all competitors last fall. For the house and out of doors. Non-freezing, and adaptable to wells from 6 to 100 feet deep. Highly recommended for city houses on account of their great power. Parties about to supply themselves are invited to call and examine. Circulars sent on application. Numbers are particularly requested to call.

See "Notes from the Pines," on page 182, May number, of *American Agriculturist*.

W. S. BLUNT,

77 Beekman Street, New York.

Self-Propelled For Cripples. Can be easily in or out doors, using the use of State your weight for illustrated different styles and

Please mention this paper.



ing Chairs and Invalids propelled, either by any one hand, and send stamp catalogue of different styles and prices.

S. A. SMITH, No. 32 Platt St., N. Y. City.



LOVEJOY'S METALLIC WEATHER HOUSES

Indicate the changes in the weather, and are pretty mantle ornaments. The little lady appears in fair and the man in stormy weather, and they never make mistakes. Sent prepaid to any address, safely packed, upon receipt of \$2 (Two), by ALVAN L. LOVEJOY, Proprietor and Manufacturer, 229 Washington St. Boston.

Special price to dealers.



CLIMAX APPLE-CORER AND SLICER.

The only practical Corer and Slicer made.

A bushel of Apples can be cored and sliced with it in ten minutes, and the work done better than by any other means whatever. Send \$1.00 for sample.

D. H. GOODELL, Sole Manufacturer, 55 Chambers Street, New York.

Also, sole manufacturer of Improved Turn-Table Apple-Parer, Lightning Apple and Peach-Parer, Family Cherry-Stoner, etc.

JAS. T. ALLEN & CO.

Have manufactured a large stock of

RICH AND MEDIUM PRICED

FURNITURE

for the spring trade, which is now on exhibition and for sale, at wholesale and retail, at their extensive

WAREROOMS,

185 & 187 CANAL ST., NEW YORK.

Established 1858.



TRADE MARK PATENTED.

The best and cheapest Paint in the world for Iron, Tin or Wood. For sale by the Trade everywhere. PRINCE'S METALLIC PAINT CO., Manufacturers, 96 Cedar St., New York. CAUTION.—Purchasers and consumers are cautioned against imitations of our METALLIC PAINT. All genuine PRINCE'S METALLIC PAINT will bear our name and trade mark on each and every package. Send for a circular.



Improved Foot Lathes.

Small Engine Lathes, Small Gear Cutters, Hand Planers for Metal, Ball Turning Machines, Slide Rests, Foot Scroll Saws. The very best. Selling everywhere. Catalogues free.

N. H. BALDWIN, Laconia, N. H. Just the articles for Artisans or Amateurs.

CABLE FENCING.

Cheap, handsome, and durable. Proof against Cattle, Fire, and Rust. Hundreds of miles erected. Send for Circulars.

PHILIP S. JUSTICE, 14 North Fifth St., Philadelphia, 42 Cliff St., New York.

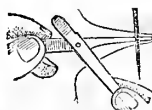

EVERY LADY that uses a Sewing Machine needs the

MAGIC THREADER

By mail, 25 cts.; with 1/2 doz. standard needles, 50 cts. Full description in *Am. Agriculturist* for April, page 133. In ordering, give name of Machine. Agents wanted everywhere. The ARGO Mfg Co., Box 312, Springfield, Mass. Please mention *Am. Agriculturist*.



BUILDING FELT.

This water-proof material, resembling fine leather, is for outside work (no tar substances used) and inside, instead of plaster. Felt carpetings, etc. Send two 3-cent stamps for circular and samples. C. J. FAY, Camden, N. J.

AMERICAN AGRICULTURIST.



PATENT DEPT.

IMPORTANT TO INVENTORS.

American Agriculturist PATENT DEPARTMENT

In compliance with the request of numerous inventors, we have organized a

PATENT DEPARTMENT

in connection with this office for the transaction of all business connected with

Securing Patents

in the United States and foreign countries.

The character for

Reliability

which has been maintained by the AMERICAN AGRICULTURIST for more than thirty years will be carefully guarded in this as in other departments.

All Inventors

desirous of procuring patents at moderate cost are invited to forward (express prepaid) a model of their invention, with a brief description of its working. The model should not exceed one cubic foot in dimension. Upon receipt of model an opinion as to patentability will be given free of charge.

Preliminary Examination

at the Patent Office, to determine patentability, will be promptly made for a fee of \$5.

Litigation of Patents.

The services of the best counsel have been secured to prosecute or protect before the U. S. Courts and the Patent Office the claims of those intrusting their business to this agency.

Specifications, drawings, engravings, models, and all other appliances furnished at moderate prices.

In all dealings with this Department inventors may depend upon promptness, fidelity to their interests, and the best services which can be rendered by thorough experts. For full particulars, address

AMERICAN AGRICULTURIST PATENT DEPARTMENT ORANGE JUDD COMPANY, 245 Broadway, New York.

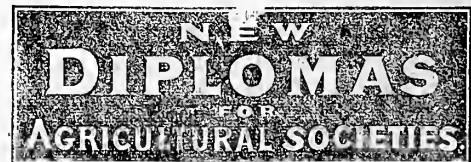

Specimens supplied by The Major & Knapp Engraving, Mfg. and Lithographing Co. 53 & 55 Park Place, N. Y.

WANTED.—The United States Life Insurance Company is now re-organizing its Agency Department, and is prepared to negotiate with gentlemen of business ability to act as Agents. Previous connection with the business is not considered necessary. Apply at the Home Office, 261 Broadway, New York. JOHN E. DEWITT, President.

BOOKS FOR FARMERS and OTHERS.

[Published and for sale by the Orange Judd Company, 245 Broadway, New York. Any of these books will be forwarded by mail, post-paid, on receipt of price.]

Table listing various books for farmers and others, including titles like 'Allen's (L. F.) American Cattle', 'Allen's (L. F.) Rural Architecture', and 'Allen's (R. L.) American Farm Book'.

Table listing books for stock and agriculture, including titles like 'Youatt and Martin on Cattle', 'Youatt on the Hog', and 'Youatt on Sheep'.

FRAMES FOR THE CHROMOS.

We have made arrangements to supply frames to our subscribers who may desire them for the Chromos which we have distributed.

Table listing frame options for Chromos, including 'For the Chromo, UP FOR REPAIRS', 'For the Chromo, LOOK OUT!', 'For the Chromo, MISCHIEF BREWING', and 'For the Chromo, THE STRAWBERRY GIRL'.

UP FOR REPAIRS, A Beautiful, New Picture for Every Subscriber to the American Agriculturist FOR 1874.

An exquisite Oil Painting by the celebrated American Painter, Mr. B. F. Reinhart, executed expressly for the American Agriculturist and entitled

UP FOR REPAIRS, has been most successfully reproduced in Chromo by the well-known firm of Bencke & Scott.

To Every Subscriber to this paper for the year 1874 received after this date, as detailed below. It is ready for immediate delivery at 245 Broadway, Free of Charge.

If to go by mail, 10 cents must be sent to cover cost of packing and postage. For 25 cents it will be Mounted, Varnished, Packed, and sent Post-paid.

N. B.—The Chromo will be delivered: At the Office, Unmounted, Free. Mounted, 15 cents extra.

The picture is designed for every subscriber upon the terms stated above, which please read carefully; and on these terms all are alike entitled to it.

BEAUTIFYING COUNTRY HOMES. AN ELEGANT QUARTO VOLUME.

By J. WEIDENMANN. PRICE, POST-PAID, \$15.00.

This magnificent work is illustrated not only with numerous fine wood-engravings, but also with seventeen full-page and seven double-page colored lithographs of places already improved.



Hussey's National Cottage Architecture. New and Original Designs, Working Scale Drawings, and Details for all Styles of low-priced Houses.

WOODWARD'S NATIONAL ARCHITECT. 1,000 WORKING DRAWINGS, Plans, Details, Specifications, and Estimates. TWELVE DOLLARS, post-paid. MONCKTON'S NATIONAL STAIR BUILDER. SIX DOLLARS, post-paid. MONCKTON'S NATIONAL CARPENTER and JOINER. SIX DOLLARS, post-paid.

Rich Farming Lands

For Sale VERY CHEAP by the
Union Pacific Railroad Co.

MILLIONS OF ACRES

IN THE

STATE OF NEBRASKA,

AT PRICES RANGING FROM

\$2.00 to \$10.00 per Acre.

Five and Ten Years' Credit Given,
with Interest at Six per Cent.

**Convenient to Markets East
and West.**

The Lands of the Union Pacific Railroad Company are the odd numbered Sections for twenty miles on each side of the road. They are located in the valley of the Platte and its tributaries—a region widely celebrated for its beautiful scenery, rich, productive soil, and mild and healthful climate. The winters are short, and the atmosphere dry and invigorating. Epidemic diseases are unknown. The surface is undulating, covered with nutritious grasses, and watered with numerous clear running streams. All the productions of the Eastern and Middle States are grown with success. Wheat and Corn are the staples, and it is well adapted to the cultivation of Fruit. For Stock-raising, in all its branches, these lands are unsurpassed. The Union Pacific and its branch railroads furnish Market Facilities unequalled. Education is free. One-eighteenth part of the entire area forms a permanent endowment of the Public Schools. Good Society, Schools, Churches, Post-Offices, Mills, Stores, and other advantages of civilization are enjoyed.

The liberal provisions made for Education, the freedom from State debt, the rapidity with which this section is settling, the numerous towns and villages springing up, offering inducements to the merchant and mechanic, render this tract a most desirable location for the industrious man of limited means to secure a comfortable home, and acquire competence, independence, and position.

These lands are granted directly to the Railroad Company. The title given to the purchaser is absolute, in fee simple, free from incumbrances. They are sold in tracts of forty acres and upwards, giving the man of small means an equal chance with the capitalist to make a safe and profitable investment, one which can not be destroyed by fire or flood, a provision for future support, not affected by *revulsions*, or liable to the fluctuations of stocks.

Full information in reference to particular localities will be furnished, good lands selected, and sales made, free of charge, for persons not desiring to incur the expense of coming to examine the lands in person.

ALSO,

THE PIONEER,

A handsome Illustrated paper, containing the HOMESTEAD LAW, mailed free to all parts of the world by addressing **O. F. DAVIS,**

Land Commissioner U. P. R. R. Co.,
OMAHA, NEB.



FOR SALE BY DRUGGISTS.

W. A. COVERT & CO., Produce
Commission Merchants, No. 68 Pearl Street,
New York. "Quick sales and prompt returns." Send
for our weekly Prices-current and Marking Plate.

AGENTS LOOK!—\$12 a day made selling
Scissors Sharpener and other wares. Sample 25 cts. Cat-
alogue free. T. J. HASTINGS & CO., Worcester, Mass.

\$25 Per Day guaranteed using our
Well Auger and Drills. Catalogue free.
W. W. GILES, St. Louis, Mo.

Tim Bunker Papers;

OR,

YANKEE FARMING.

By **TIMOTHY BUNKER, Esq.,**

OF HOOKERTOWN, CONN.

WITH ILLUSTRATIONS

By **HOPPIN.**

CONTENTS.

- | | |
|---------------------------------------|---|
| 1.—A Stroke of Economy. | 45.—The Farmers' Club. |
| 2.—Ornamental Trees. | 46.—On Bad Water. |
| 3.—Timothy-Bunker, Esq. | 47.—Cattle Disease. |
| 4.—View of the Bird Law. | 48.—On Seed. |
| 5.—Guano in the Hill. | 49.—On Breastworks in War. |
| 6.—On Moss Bunkers. | 50.—Lightning Rods. |
| 7.—On Subsoiling. | 51.—Buying a Farm. |
| 8.—Going to the Fair. | 52.—Top-dressing and Feeding |
| 9.—In Tall Clover. | Aftermath. |
| 10.—On Horse Racing. | 53.—Painting Buildings. |
| 11.—At the Farmers' Club. | 54.—The Value of Muck. |
| 12.—On an Old Saw. | 55.—On Family Horses. |
| 13.—Book Farming in Hook-
ertown. | 56.—The Horn-nail. |
| 14.—Pasturing Cattle in Roads. | 57.—A Commentary on Roots. |
| 15.—The Weaker Brethren. | 58.—Stealing Fruit and Flow-
ers. |
| 16.—Curing a Horse Pond. | 59.—The Cost of Pride. |
| 17.—Domesticities at Tim
Bunker's. | 60.—Swamps Furling Indian. |
| 18.—Takes a Journey. | 61.—Tim Bunker in his Garden. |
| 19.—On Farm Roads. | 62.—On Running Asteru. |
| 20.—A New Manure. | 63.—On Extravagance. |
| 21.—Losing the Premium. | 64.—The Farmer's Old Age. |
| 22.—A New Enterprise. | 65.—On Sheep Traps. |
| 23.—Making Tiles. | 66.—Old-Style Housekeeping. |
| 24.—The Clergy and Farming. | 67.—On Keeping a Wife Com-
fortable. |
| 25.—Women Horse Racing. | 68.—Starting a Sugar Mill. |
| 26.—Beginning Life. | 69.—Reasons against Tobacco. |
| 27.—An Apology for Tim Bun-
ker. | 70.—Trip to Washington. |
| 28.—On County Fairs. | 71.—The Sanitary Commission. |
| 29.—At Home again. | 72.—Raid among the Pickle
Patches. |
| 30.—On Raising Boys. | 73.—Raid among the Pickle
Patches. |
| 31.—On Raising Girls. | 74.—On Striking Ile. |
| 32.—A New Case of the Black
Art. | 75.—Visit to Titus Oaks, Esq. |
| 33.—A Letter from Neighbors. | 76.—The Pickle Fever in
Hookertown. |
| 34.—The Shadtown Parsonage. | 77.—On Curing Pickles and
Eating them. |
| 35.—Views of Dress. | 78.—The Cotton Fever and
Emigration. |
| 36.—A Rustic Wedding. | 79.—The Cotton Fever and
Emigration. |
| 37.—Saving a Sixpence. | 80.—The Food Question. |
| 38.—On Giving Land a Start. | 81.—On Jim Crow. |
| 39.—On Giving Boys a Start. | 82.—The Eight-hour Law. |
| 40.—A Tie in the Head. | 83.—Base Ball Clubs. |
| 41.—Jake Frink Sold. | 84.—The Rise of Real Estate. |
| 42.—The New York Central
Park. | |
| 43.—On Irrigation. | |
| 44.—Feeding with Oil-Meal. | |

SENT POST-PAID, PRICE \$1.50.

ORANGE JUDD COMPANY,
245 BROADWAY, NEW YORK.

CARPENTRY MADE EASY;

Or, The Science and Art of Framing, on a new and im-
proved system. With specific instructions for Building Bal-
loon Frames, Barn Frames, Mill Frames, Warehouses,
Church Spires, etc. Comprising also a system of Bridge-
building, with Bills, Estimates of Cost, and Valuable Tables.
Illustrated by Thirty-eight Plates and near Two Hundred
Figures.

By **WILLIAM E. BELL,**

ARCHITECT AND PRACTICAL BUILDER,

Price, Post-paid, - - - - \$5.00.

Address

ORANGE JUDD COMPANY,
245 BROADWAY, NEW YORK.

Beckwith Sewing Machines

\$12 and \$20.

We have offered as a Premium, and also for sale, for more than a year past, the **Beckwith Sewing Machine**, which has been fully described in previous numbers of this paper. We have already given and sold more than one thousand of these machines, and testimonials of satisfaction have come from every quarter.

We still offer the **Beckwith Sewing Machine, Improved**, price \$12. A new and very simple braiding-foot has been made, by which a child can sew on braid without the least trouble, following any desired pattern with ease; also a new arm, spiral spring and lever for raising the presser-foot, all of which are now set in a position that leaves the needle free to be threaded. The joint is much enlarged, and the machine is otherwise greatly strengthened and improved. The use of the braider-foot alone will be valued more than the cost of the machine.

Each of these machines is put in a neat, compact box, with *hemmer and guide, oil-can with oil, thread, different-sized needles, etc.*, with full Printed Directions for using. On receipt of \$12 we will send one of these machines to any address, expressage to be paid by the purchaser.

The Machine as a Premium.

We will give one of these \$12 machines to any one who will collect and forward sixteen subscribers to *American Agriculturist* for one year, at \$1.50 each, expressage on the machine to be paid by the recipient of it.

THE BECKWITH PORTABLE FAMILY SEWING MACHINE.

PRICE \$20.

Enlarged and Improved. Its Weight is 7 Pounds.

While we continue the offer of the Improved \$12 Machine as heretofore, we now offer the new

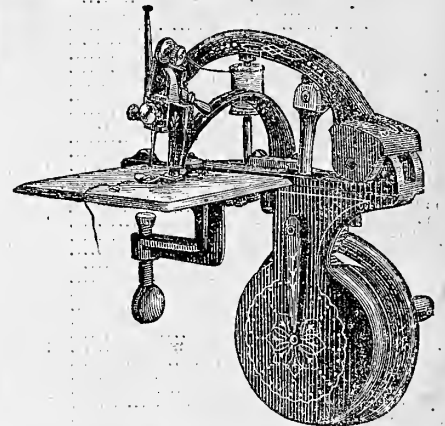

PORTABLE FAMILY MACHINE,

price \$20, which comprises all the excellencies of the former, with many valuable improvements. Its size and power are increased, and its capacity thus very much enlarged, without impairing its portability. There have been added cam and eccentric movement, a balance-wheel, and also an oscillating needle-clamp, by which the length of stitch can with the greatest ease be changed to the finest shade of variation without touching the needle.

To any one sending us \$20, we will send one of the Machines (packed in a neat, portable case, with handle to carry it easily), expressage to be paid by purchaser.

The Machine as a Premium.

We will give one of these \$20 Machines to any one who will collect and forward to us **Thirty Subscribers to American Agriculturist** for one year at \$1.50 each, or **One Hundred** at \$1 each, expressage on the Machine to be paid by the recipient of it.

Almost any lady can readily secure the small number of subscribers required to get either the \$12 or the \$20 Machine as described above; or some friend can thus obtain it for her as a present.

ORANGE JUDD COMPANY,

245 BROADWAY, NEW YORK.

AUGUST, 1874.

AMERICAN

AGRICULTURIST

FOR THE FARM, GARDEN & HOUSEHOLD

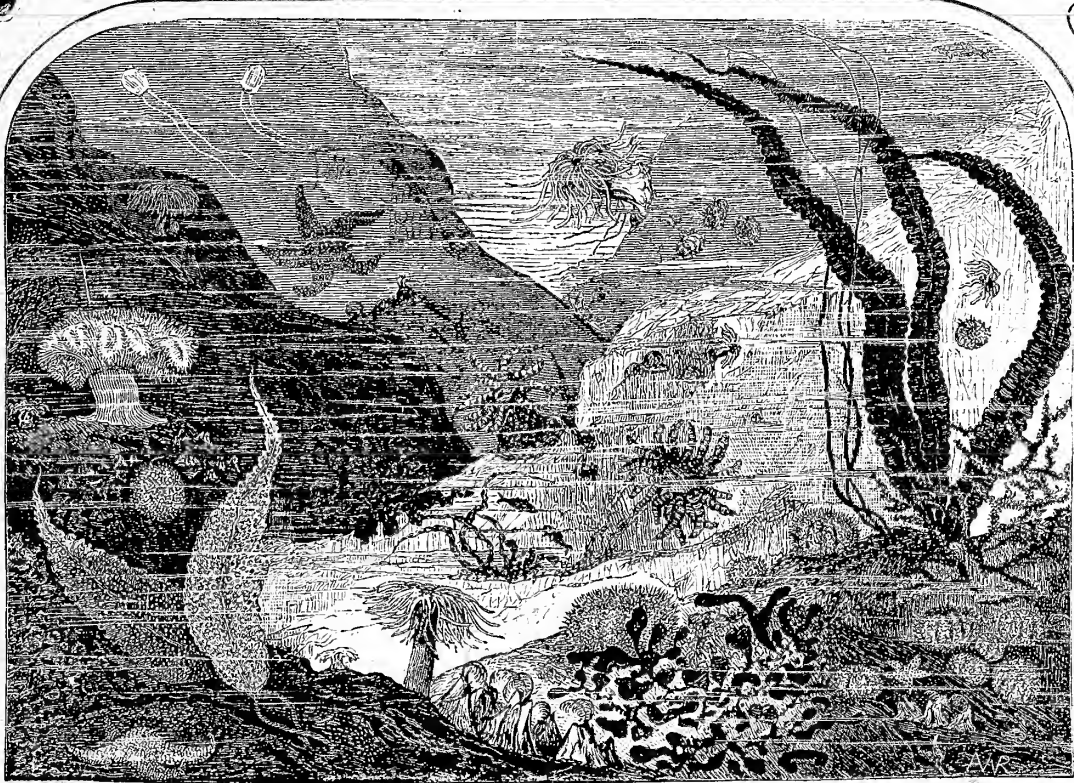

Vol. XXXIII

Number 8



PUBLISHED BY THE
ORANGE JUDD COMPANY,
245 BROADWAY,
NEW-YORK.



BOOKS for FARMERS and OTHERS.

[Published and for sale by the Orange Judd Company, 245 Broadway, New York. Any of these books will be forwarded by mail, post-paid, on receipt of price.]

Table listing various books for farmers and others, including titles like 'Allen's (L. F.) American Cattle', 'Bailey's Our Own Birds of the United States', and 'The Home Corn-Sheller'. Includes prices for each item.

Table listing books for stock and other agricultural topics, including titles like 'O. J. Co. keep in Stock the following Books', 'Architecture, by Cummings & Miller', and 'Art of Saw Filing'. Includes prices.

FRAMES FOR THE CHROMOS.

We have made arrangements to supply frames to our subscribers who may desire them for the Chromos which we have distributed. Many will no doubt avail themselves of this opportunity to place these beautiful pictures in handsome frames at moderate cost.

Table listing frame options for Chromos, including 'UP FOR REPAIRS', 'LOOK OUT!', 'MISCHIEF BREWING', and 'THE STRAWBERRY GIRL'. Includes prices for different frame styles and sizes.

ROCK'S NEW CRANGER HAY & COTTON PRESS, SIMPLEST AND BEST IN USE.

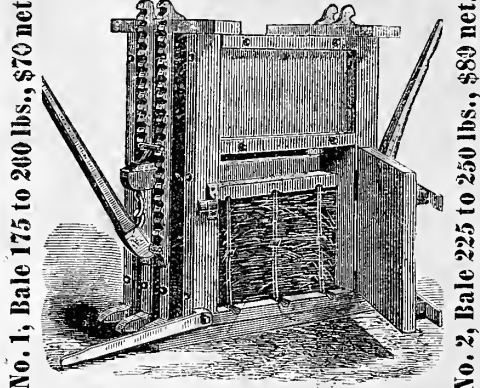

Has taken First Premium over all Presses wherever exhibited; also Prize Medal at American Institute Fair, 1872. To parties wishing to alter their old presses to this plan, the machinery will be furnished complete with cut and instructions for \$250.

\$25 A DAY GUARANTEED using our WELL AUGER & DRILL in good territory. Endorsed by Governors of IOWA, ARKANSAS & DAKOTA.

ENGLISH CHANNEL RAGGED SOLES are never seen in ENGLISH CHANNEL Shoes. These shoes are all the rage. Ladies, ask your dealer for them.

INVENTORS Who wish to secure PATENTS should write to MUNN & CO., 37 Park Row, New York, for Advice and Pamphlet, 103 pages, F.R. 10c.

The Home Corn-Sheller.

The best hand-sheller for family use in the market. EVERY MACHINE WARRANTED. Price, \$2.50. Live Agents wanted. Address, LIVINGSTON & CO., Pittsburgh, Pa.



In addition to the 20 Cast Steel Tools enclosed in this Handle, it will hold anything from an 8-inch Mill File to a Cambric Needle. It is by far the best Tool folder in use, and will also answer nearly all the purposes of a Hand Vise.

PAYSON'S INDELIBLE INK.

This Ink is almost indispensable in the family. Briggs's Marking-Pen has been before the public for fifteen years, and is justly celebrated for all kinds of marking, and particularly for writing upon coarse fabrics.

ADVERTISING RATES.

English Edition. Inside Pages, \$1.50 per line (agate), each insertion. Open Pages (open without cutting), \$2 per line. Last Page, and 2d and 3d Cover Pages—\$2.50 per line. Page next to Reading and Last Cover Page—\$3.00 per line. No advertisement inserted for less than \$5.00. German Edition. Inside Pages, 25 cents per line, each insertion. Business Notices and Last Page, 40 cents per line. No advertisement inserted for less than \$1.00.

AMERICAN AGRICULTURIST

FOR THE

Farm, Garden, and Household.

"AGRICULTURE IS THE MOST HEALTHFUL, MOST USEFUL, AND MOST NOBLE EMPLOYMENT OF MAN."—WASHINGTON.

ORANGE JUDD COMPANY,
PUBLISHERS AND PROPRIETORS.
Office, 245 BROADWAY.

ESTABLISHED IN 1842.

Published also in German at \$1.50 a Year.

{ \$1.50 PER ANNUM, IN ADVANCE.
SINGLE NUMBER, 15 CENTS.
{ 4 Copies for \$5; 10 for \$12; 20 or more, \$1 each.

Entered according to Act of Congress, in July, 1874, by the ORANGE JUDD COMPANY, at the Office of the Librarian of Congress, at Washington.

VOLUME XXXIII.—No. 8.

NEW YORK, AUGUST, 1874.

NEW SERIES—No. 331.



THE NEST OF THE OSPREY, OR FISH-HAWK.—(See page 291.)—Drawn and Engraved for the American Agriculturist.

Contents for August, 1874.

Barn for Sheep... 4 Illustrations... 297
Bee Notes... 290
Birds—Osprey or Fish-Hawk... Illustrated... 282, 291
Boys and Girls' Columns—Boys' Pigeon House—
Aunt Sue's Chats—What six pecks of Potatoes
did—Puzzle-Box, Answers to Puzzles—The New
Comers... 3 Illustrations... 307, 308
California Tobacco... 299
Cattle, Animals for Exhibition and for use... 2 Ill... 293
Clearing Stubble... 290
Edam Cheese... 5 Illustrations... 295, 296
Farm Work for August... 282
Flower Garden and Lawn in August... 283
Flowers, Preserving—Winter Bouquets... 303
Flowers, The Japanese Primrose... 304
Flowers, The Manihot Iibiscus... Illustrated... 304
Fruit Garden in August... 283
Greenhouse and Window Plants in August... 284
Household Department—Comfortable Country Chairs
—Padding—Sponge Cake—Catsup—Home Topics—
Berrying—That Frying Pan—Small Waists—Bread
Crackers—Apple Pies for Lunchees—A Mother on
Bathing... 2 Illustrations... 305, 306
Hurdles, How to Arrange... 2 Illustrations... 299
Kitchen Garden in August... 283
Machine-Made Ox Shoe... Illustrated... 296
Market Reports... 284
Notes from the Pines—American Wistaria—Base-
Burner water-heater—Robbery of Shrubs—Insects
and Horticulture—Flowering Shrubs—Straw-
berries... 302, 303
Ogden Farm Papers, No. 54—A Tasting Chemist—
Jersey Crosses—Mr. Hand's Herd—Water and Wind
Mills—Sales of Cattle... 291, 292
Orchard and Nursery in August... 283
Outlet to a Swamp... Illustrated... 298
Ox Bow, How to Bend... Illustrated... 297
Patents and Patent Departments... 290
Potato Bug in the West... 290
Poultry, Cramming... 299
Rat-trap, a Permanent... 2 Illustrations... 300
Shrub, The Tree-flowering Andromeda... Illustrated... 301
Siphons and Water Pipes... Illustrated... 298
Sour-Podder Making in Hungary... Illustrated... 297
Strawberries, Some new Varieties... 303
Succulents as Decorative Plants... 4 Illustrations... 301
Swindling by Mail... 290
Transportation Problem—Steam on Canals... Ill... 299, 300
Walks and Talks Correspondence... 289
Walks and Talks on the Farm, No. 128—Harrowing
Wheat—Red Root—Weight of Lambs—Mr. Croziers'
Farm and Farming... 294, 295
Wild Mustard, To Kill... 291

INDEX TO "BASKET," OR SHORTER ARTICLES.

Acrobats... 285
Ammonia in Peat... 289
Blight—Tiles... 287
Bloody Urine... 313
Bones, Use for... 287
Butter Convention... 287
Carpenter's & Bld'r's Guide... 288
Cattle Trade in N. Y... 289
Clay Pasture... 313
Clover, Effect... 288
Colorado Sheep Farm... 287
Colt, Lame... 288
Conn. Board of Agri... 287
Corn Cobs... 313
Cotton—Improvements... 289
Cribbing Horse... 288
Crop for Wet Soil... 313
Crop Reports... 287
Dairying Question... 312
Death of a Duchess... 287
Death of Mr. Olm... 286
Devon Herd Book... 288
Dick's Success... 313
Doubtful Case... 288
Draining Sandy Soil... 313
Drains, How they Act... 289
Eggs for Hatching... 287
Emigration to Va... 288
Epilepsy in Pigs... 313
Farm Students... 288
Flatulence in Horses... 287
Flax Crop... 287
Frois, Protrusion in... 313
Fruit and Vegetables... 288
Furnace for Wood... 288
Gas-lime, Value... 313
Grain Weevils... 287
Grasshoppers in Minn... 285
Ground Bones... 288
Gypsum in Va... 288
Hall and Horticulture... 287
Hair, Stimulating... 313
Harrowing Question... 313
Hawks, to Catch... 313
Hollyhock Disease... 287
Horse Books... 289
How Books Sow Seeds... 288
Indefinite... 287
Inflamed Hook... 313
Irish Farming... 288
Lands in E. Va... 288
Learning Farming... 288
Leaves, Value of... 313
Lock Nut & Bolt Co... 287
Losing the Hair... 313
Manuscripts... 285
Maps' Superphosphate... 287
Merino Ram... 288
Mule with Colt... 287
Nameless People... 285
Onion Grub... 288
Parrots... 288
Patrons of Husbandry... 287
Pea-Bug... 287
Practical Farmer... 286
Preserving Eggs... 287
Preserving Posts... 287
Propensity in Sheep... 313
Railway Horse-Powers... 287
Restoring Butter... 313
R. I. Society... 288
Bye for Pasture... 288
St. Joseph & Denver R.R... 287
Savdlust... 287
Sebastopol Geese... 288
Sheep, Best... 288
Sheep Books... 288
Sheep for Ohio... 313
Sheep in Nebraska... 284
Spasmodic Colic... 313
Stable Floors... 288
State Fairs... 289
Steamed Food... 313
Stone Drains... 288
Street Manure... 287
Sundry Humbugs... 285
Swiss Colony... 287
Tan for Stables... 287
Tile Drains... 289
Vitality of Eggs... 288
Warts on Horse... 313
West, What Part... 289
Wild Onion... 313
Wis. R. R. Decision... 286
Wool Waste Manure... 286
Yield of Roots... 287

Calendar for August.

Table with columns for Day of Month, Day of Week, and Moon phases for various locations: Boston, N. Eng., N. York, Philadelphia, N. Jersey, N. Ohio, Indiana, and Illinois, Washington, Maryland, Virginia, Kentucky, Missouri, and California.

PHASES OF THE MOON.

Table showing moon phases for Boston, N. York, Vasan, Ches'ton, and Chicago, with columns for Moon, Day, Hour, and Minute.

AMERICAN AGRICULTURIST.

NEW YORK, AUGUST, 1874.

The American Agriculturist is for the whole country. It is devoted, not to one section alone, but to East and West, South and North alike, and it aims to give such information as shall be useful and practical everywhere. In our wide country with a great diversity of climate, the ways and needs of farmers differ somewhat. The principles upon which they work, however, are the same everywhere; good cultivation, killing weeds, gathering manure, sowing good seed, making the most of the crops grown, treating the farm stock in the best manner, and practising economy, all bring about the same profitable results everywhere. We endeavor to teach principles, and to show our readers how they may adapt their practices to them. Just now is an excellent time to study a few of the first principles of good farming. There is as much leisure in this month as a farmer usually enjoys. He should use this to take a rest. Haying is over, and fall wheat is harvested. Corn is laid by, and by the middle of the month oats and spring wheat will be cut. There is plenty of work to be done, but it can lie over a few days without damage, or those who must stay at home to take care of things can attend to them. Every farmer who can, should go from home with his wife, and visit some other locality. The Western farmer should go East, and the Eastern one should go West, and both should exchange places for a few days with the Southern plauter. By doing this, much valuable knowledge will be gained, and new ideas gathered. When he comes back, he will probably think his own place the best he has seen, or will have found out how he can make it so. There will be less local jealousy, and each will learn that his brother farmers have all something to contend with. If there is the grasshopper or the chinch bug in one place, there is the Hessian fly or the army worm in another, and there is in each locality some drawback. The farmer who travels will soon learn that it is in ourselves and not in our fortune that we are thus or thus. He will come back more contented with his lot, more determined to make the most of the advantages he enjoys, and better able to do it than before.

Hints about Work.

Oats, although the season is backward, will soon be ready to harvest. They should be cut before they are dead ripe. When ripe they shell badly and many are lost. The straw is also better for feed when cut early. The use of damp rye straw for bands in binding, will save time as well as oats.

Buckwheat may be sown the first week in this month, and yet escape frost. It is a crop which costs little to put in, and pays well for the cost. If injured by an early frost it is worth all the expense for plowing under.

Corn should not be laid by while a horse can pass through the rows. A muzzle will prevent him from biting the stalks. The soil should be kept stirred, and not allowed to bake after a shower. Late weeds rob the crop as much as early ones. If they are allowed to ripen their seeds, they will do a vast amount of mischief. These should be removed by hand. No plow should be used to work corn at this late season. The roots now occupy the whole ground. Two inches of mellow soil on the surface, will keep the soil moist, and no deeper cultivation should be given. In rich prairie soils, and where fall pasture is scarce, rye may be sown in the rows at the last working. This will give valuable late pasture or early spring feed. But generally such stolen crops are better avoided. Pumpkins grown amongst corn are as bad as weeds. Better have a portion of the ground prepared for such crops.

Root crops must not be neglected. They must be kept clean, and thinned out severely. Strap-leaf turnips may be sown early this month. Use plenty of seed, two pounds per acre, sown in drills 24 to 28 inches apart, will not be too much for safety. 150 lbs. of superphosphate, fine bone flour, or Peruvian guano near the seed, will greatly help the crop. With roots the start is the great point. Thin out to 12 inches apart in the row, when the plants are well established, and keep the ground free from weeds. Home grown seed is better than imported.

Grass fields will be greatly benefitted by a top dressing of fine manure. If nothing better can be had, a few loads of rich soil from roadsides or scrapings of the barnyard may be spread. It is poor economy to pasture meadows or young clover, good care at this season will strengthen the roots, and give a heavy aftermath which may be pastured by and by.

Pastures need looking after. Bare and mossy spots should be harrowed, sowed with fresh seed, and a dressing of lime and ashes or plaster, may be given. A bushel of salt per acre is often very useful. Weeds should be cut with the mowing machine, and gathered and burned. Brush should be cut close to the ground, with a short stiff scythe or a brush hook.

Weeds should be kept down everywhere. Thistles, wild parsnips and carrots, mulleins and burdocks, in neglected corners and fence rows, should be cut up by the root, and the tops gathered and burned. Many weeds are now ripening their seeds, and if neglected will make work for many years to come.

Drainage may now be laid out for future completion. Springy places should be staked, and the course of a drain that will carry off the water, should also be staked out. Swamps are now dryer than usual, and ditches may be dug comfortably. Throw out the muck on one side of the ditch only. Put it in heaps, and not in a continuous row, which would prevent surface water flowing into the ditch by and by. The muck will be dry before winter, and so will the ground. The muck can then be easily hauled at any time to the barnyard. Read Ogden Farm papers for last month once more.

Saving Seed.—A large quantity of grass seed may be saved, by cutting the ripe bunches from clean fence rows, or patches which may have been left for this purpose in the meadows. Where any variety of grass grows unmixed with others, it should be left in this way. The grass may be cut with a grass hook, tied in bunches and thrashed or rubbed out, and the seed saved in grain bags. This is a little thing, but hundreds of such little things

may be done in a year upon a farm, and in the whole are worth looking after.

Manure, making is always in order. Everything that can add to the pile should be gathered. Coarse weeds that have no seed in them may be put into heaps, with a few bushels of lime and covered with earth. They will soon decay and make a good dressing for grass lands or pastures. Or they may be added to the barnyard manure. Early potato-tops, sods from the roadside, road dust, and all such matter should be added to the compost heap. It will ferment rapidly in the hot weather, and if turned over or wetted with liquid manure, it will be ready for use next month for the wheat or rye ground.

Thrashing should be done as soon as possible. Grain is safe from many enemies in the granary. Besides it is the same as so much cash, and is equally available. Markets should be closely watched this year. It is difficult to say how they may turn. An advance is just as likely as a decline, and with wheat in the granary it can be taken advantage of. Seed wheat should be carefully selected. The heaviest grain only should be taken, and there should be no cracked kernels in it. This should be looked to while thrashing. If the thrashing machine is hired, a farmer should do nothing but watch things. Watch the straw closely, and see that no grain is left in it. See that the hired teams do their share of the work. If a steam thrashing machine is used, see that it does not effect the insurance on the barn. For farms of less than 100 acres, a good two horse railroad power machine is probably the best. With a cleaner attached it is so much the better. The whole may be set in the barn, and grain may be thrashed any day at an hour's notice. There need be no waste of straw. As a mow is emptied of grain, the straw should be returned. This is better than stacking it out of doors. Before long there will be few places in the country, where it will pay to throw the straw away.

Plowing for Wheat upon oat-stubble should be done as soon as the oats are off. A light furrow, to cover the stubble, is sufficient. The oats left upon the ground that the pigs have not gathered, will soon sprout. When they are well started, a thorough cultivation will kill them. If a clover sod is to be plowed, it should be turned perfectly flat. If lime is to be used, it should be drawn now, and piled upon the plowed ground in small heaps. A bushel to every two rods each way will give 40 bushels to the acre. The heaps will slack in a few days, or with one shower. The lime may then be spread evenly, and the ground left until next month.

Horses should not be stinted in their feed. Work-horses should be put out to pasture at night, but they should have their usual allowance of other feed. They have some lost flesh to make up. Scrape off the eggs of the bot-fly from their fore-legs and shoulders with a sharp knife, or wash them off with warm water every evening. Three hour's rest at noon is not too much for the team while plowing. The time may be made up at morning and night. This arrangement is not a bad one for the driver as well. Give water often, and don't forget a handful of corn-meal stirred into it.

Colts may be taught to eat a little meal or bran, and to be handled freely. The gentlest possible treatment should be given to all young stock at this season, and careful attention.

Cows need extra feed, or they will fall off in milk. Corn, or other green fodder, should be given them daily in addition to their pasture. Carbolic soap-suds left to dry upon their legs, will keep flies at a distance. Three hours at noon in a cool, clean stable will be a grateful change for them from a hot, unshaded pasture.

Calves may be turned into a good clover aftermath, or a wheat-stubble, if the young clover is thrifty. Half an ounce of salt daily will prevent bloat. If they can get skimmed, or even sour milk, until six months old, they will be the better for it.

Sheep.—Lambs should now be weaned, the rams separated from the flock, and put in a field by themselves. A little extra feed may be given to the rams. The lambs should have a handful of

mixed bran and oil-cake daily. They will be more contented if put in a field out of sight of the ewes. The ewes should be looked after daily, and those with full bags should be eased of a portion of the milk. This should be done every night, until they are dried off. Ewes, which are the best nurses, may be put with the rams for early lambs in January. Look out for ticks and the fly maggot in spots accidentally bruised, or where filth gathers. Tar smeared upon the noses will keep away the gad-fly. Above all things, keep sheep out of wet, marshy pastures.

Swine.—This is a critical time for hogs where cholera is frequent. Furnish those at pasture with shade and plenty of clean water. Give them a little salt (about an ounce each) daily. Watch for the first sign of sleepiness and a desire to hide in quiet places by themselves. When this is seen, pen up the hog, and give 4 ounces of salt, and soft food with some linseed meal. Store hogs may be penned for fattening. One pound of corn now is worth two in November. Besides, every rod they run about uses up fat. Boars should be kept from the sows, unless pigs are wanted to come in Dec.

Poultry.—Vermin increase fast at this season. No fowls will thrive if kept in close, filthy quarters, where lice abound. A coat of hot lime-wash, with an ounce of carbolic acid dissolved in it, will free the roost from lice. Clear out all the droppings, and spread them evenly in the compost heap. As the old fowls get fat upon the stubbles and in the straw yard, they should be sold off or used in the kitchen. A stewed fowl is more wholesome food than fried pork at this season. To give fowls the run of the barn is a wasteful practice.

Sundry Matters.—If there is no insurance upon the barn, one should be procured without delay. The vapor from a barnful of new hay or grain is one of the best conductors of lightning. Bathe the whole body with cold water every night, and rub briskly with a dry towel. This brings refreshing sleep, and conduces to health. Give the men and boys a bucket with soap and towels, that they may do the same. They will work the better for it.

Work in the Horticultural Departments.

August brings a short breathing spell to the gardener, if he has been diligent in the killing of weeds. If there are in the garden or orchard, any corners and neglected spots, where the weeds are allowed to grow and ripen their seed, these spots will furnish a bountiful supply of weed seeds for perpetuating the crop, so that the quantity is not perceptibly diminished year by year, as it should be. These corners ought to have a thorough clearing out, and not a weed allowed to ripen its seed. This will be a great aid in keeping the place in order. If the work is well along now, a few days of rest and quiet, either in the mountains or at the seashore, will be appreciated by all hands, or even a day's picnic in a cool grove will give them a pleasant change.

Orchard and Nursery.

For trees that were planted in the spring, the present month will be a trying one, and unless they were properly mulched, many will not survive the hot, dry weather. No danger need be feared if a thick layer of hay or straw, corn-stalks, or other material, has been placed around each tree, as this will keep the ground constantly cool and moist, and also prevent the growth of weeds.

Marketing will engage the attention of most fruit growers this month, and everything ought to be in readiness for carrying it on rapidly. Baskets, crates, barrels, or whatever is used should be provided in sufficient quantity, so that no time need be lost for want of them. See that the packing is done carefully, so that the fruit will not be unnecessarily bruised in transportation. Try to gain a good name for quality, this will always sell the fruit, even during times of plenty, for most buyers will pay more for a first class article, than for a poor one.

Weeds.—There need be no trouble from weeds if they are not neglected; a horse and cultivator between the rows of the larger trees and shrubs, and a hand cultivator among the small plants and seedlings, will be found amply sufficient.

Insects will infest the fruit trees in many sections at this season of the year, and they ought not to be neglected. Much immature fruit will fall, and this on examination will be found to contain insects; this fruit should be given to the pigs, or if convenient allow the pigs the run of the orchard. Destroy the nests of the late web-worms as soon as they appear, else they will soon eat up the entire foliage; the best method is to take out the nest by hand, or if neglected so long that they spread, cut and burn the infested branches.

Budding may be performed whenever the bark will lift readily, and well-ripened buds can be had. The maturity of the buds may be hastened by pinching the ends of the shoots on which they are borne. When sticks of buds are taken, cut off the leaves, and leave the leaf-stalk attached to the twig; keep the twigs moist until used.

Fruit Garden.

The same directions as to picking and marketing fruit, apply as well here as in the orchard. All surplus fruit should be dried or canned.

Dwarf Trees.—Pick off all deformed fruit, and also thin out where too thick.

Grapes.—Use sulphur as soon as mildew appears. Tie the vines to trellises or stakes.

Blackberries.—Allow only three or four canes to grow, and pinch these off as soon as they reach a height of five or six feet, and stop the laterals when eighteen inches long. Allow the fruit to remain on until thoroughly ripe when for family use; for marketing pick before fully ripe.

Raspberries.—Cut out the old fruiting canes as soon as they have finished bearing, and apply a dressing of manure, forked in between the rows.

Strawberries.—The latter part of this month is a good time to plant new beds, if the plants can be watered and shaded. Remove the mulch from the old beds, and take out all weeds, and cut off all runners not needed for forming new plants. The best manure for newly planted beds is either wood-ashes, or ground bone raked in, if stable manure is used it should be well rotted, or else it will bring in an abundance of weeds.

Kitchen Garden.

Asparagus must not be neglected, as often happens, through the pressure of other work. If the bed is allowed to become weedy, the next year's crop will be injured. Hoe frequently to kill the weeds and keep the soil light.

Beans.—Although rather late for a crop, a few may be planted for late snaps or for salting. Keep the pole and bush sorts well hoed and weeded.

Cabbages and Cauliflowers.—Hoe frequently, and as often as possible, in the early morning when the dew is on. Apply liquid manure as often as convenient, it will help their growth wonderfully during this hot dry month.

Carrots.—Cultivate between the rows until the tops cover the ground; hand-weed the rows when the weeds appear. Thin out the late sowings.

Celery.—Prepare the land, and set out the plants the middle or last of this month, for winter use. The winter crop should be earthed up and the ground well cultivated.

Corn.—Keep the weeds down by cultivation and pull the large ones from the rows by hand. Cut off and burn all smutty ears. The stalks of earliest varieties, from which the ears have been picked, should be cut for fodder, and the ground sowed to late turnips.

Cucumbers.—Gather for pickles every day; the small ones, not over two or three inches long, make the best pickles. The over-grown ones may be made into cucumber catsup, for winter use.

Egg Plants.—The warm weather of this month is

best suited to the growth of these, and they will be benefited by a few applications of liquid manure. Place a handful of hay or straw around each plant, to keep the fruit from touching the ground.

Melons and Squashes.—Cultivate until the vines cover the ground, and pinch back the ends if disposed to run to vine.

Onions may be harvested as soon as a majority of the tops fall down. Pull and allow to dry for several days before storing; keep in a dry airy place, spreading in thin layers, so that they will not heat. Store sets in the same way.

Spinach.—Sow the last of the month, for fall use.

Sweet Potatoes ought to be growing rapidly at this season. Keep the ridges free from weeds, until the vines cover the ground; move occasionally to prevent them from taking root.

Tomatoes.—Keep tied up to trellises, or place brush or hay around them to keep the fruit from touching the ground. Kill the green worm.

Turnips may be sown in spots where potatoes, peas, and other early vegetables have been taken off.

Weeds.—The best and only rule in destroying weeds, here as well as everywhere, is to hoe or cultivate them up, just as they show their heads above ground. After a rain the cultivator should be started, as the moisture will bring up a plenty.

Flower Garden and Lawn.

The warm weather of the preceding month has started weeds into luxuriant growth, and if they are not pulled up, the beds will soon be overrun. A narrow iron rake makes the best implement to work with in a flower bed where the plants are set out at irregular distances.

Do.—Where this is used for edging, this month is the time for clipping.

Lawns should be mowed as often as necessary, just enough to keep the grass short and velvety.

Climbers.—Tie up neatly to stakes, trellises, or whatever else is used for supports.

Edgings need a good deal of care to keep them looking well. Cut the margins with a sharp turf knife, and keep the grass cut close.

Dahlia, Old'rose, and other plants requiring stakes, should have them at once, before they get so high that they are broken by the wind.

Planted Plants in tubs or pots set on the lawn for decoration, need to be watered often.

Perennials.—Prepare a bed of fine soil, where seeds can be sown as fast as they ripen; keep well watered and weeded.

Greenhouse and Window Plants.

Give hanging baskets and window boxes plenty of water and shade, the latter during the middle of the day. See that the greenhouse is kept clear of insects, the tendency being to neglect this during the heat of summer. Make all necessary repairs now, so that everything will be ready for use at a minute's notice. Provide plenty of pots, sand, moss, and potting soil, for use during the fall and winter.

Commercial Matters—Market Prices.

The following condensed, comprehensive tables, carefully prepared especially for the American Agriculturist, from our daily record during the year, show at a glance the transactions for the month ending July 11th, 1874, and for the corresponding month last year:

Table with 2 main sections: 1. TRANSACTIONS AT THE NEW YORK MARKETS. 2. Comparison with same period at this time last year. Columns include Receipts, Flour, Wheat, Corn, Rye, Barley, Oats, and Sales.

Stock of grain in store at New York. Table with columns for Wheat, Corn, Rye, Barley, Oats, and Malts. Includes sub-sections for Exports from New York and Receipts at head of tide-water at Albany.

CURRENT WHOLESALE PRICES. Table listing prices for various commodities like Flour, Wheat, Corn, Rye, Barley, Oats, Peas, Beans, etc., with columns for current prices and prices from June 12th and July 11th.

Gold has been up to 112 1/2 and down to 109 1/2—closing July 11th at 110 as against 111 on June 12th. Breadstuffs have been quite active since our last; but under the influence of very heavy receipts from the interior, and favorable crop reports, prices have been seriously depressed and unsettled.

ton has been quoted lower, on a lighter business, mostly speculative. Provisions have been in brisk request, especially hog products, which have been purchased freely on speculative account. Wool has been in much better demand, and generally firm as to values, with unexpectedly high prices ruling in the interior, partly through speculative operations. Hay, Hops and Seeds have been quiet, and somewhat irregular in price. Tobacco has been more sought after at rather higher quotations. Kentucky having been especially brisk, in view of the less favorable crop reports. Eggs have advanced materially, influenced by the lighter offerings, and the more active demand.

New York Live-Stock Markets.

Table showing Receipts and Week Ending for various live stock categories: Beef Cattle, Sheep, Swine, etc.

Beef Cattle.—The course of the market for the past month has been downwards. A large increased supply, chiefly of poor lots, weakened the market early in the month, and the light demand consequent upon the hot weather for two weeks finally broke down prices July 1 cent a pound. Large offerings have been the rule up to last Monday, when a reduction of 2,300 head from the previous week stiffened prices, and made an active market. Prices of ordinary stock advanced most, and a gain of a cent per pound was made. Extra stock advanced 1/4 to 1/2 cent per pound. At the close, common to prime native steers and oxen were sold at 10 1/2 to 12 1/2 c. to dress 56 to 58 lbs. to the gross cwt; extra and fancy do. at 12 1/2 to 13 c. to dress 58 lbs.; and poor through Texans to good Northern corn-fed do., from 7 1/2 c. to dress 54 lbs., up to 10 1/2 c., to dress 57 lbs.

Table showing prices for the past four weeks for various live stock categories: Beef Cattle, Sheep, Swine, etc.

The managers of the three main railroad lines that supply this market with live stock, viz: the New York Central, Erie, and Pennsylvania Central, have arranged to advance and pool live stock freights from the West, and the new schedule is as follows:

Table showing rates for various live stock categories: Beef Cattle, Sheep, Swine, etc., with columns for From Chicago to New York, From Chicago to Philadelphia, etc.

It is understood and agreed that the rates shall be uniform and equal to all parties over either and all of the roads; that there shall be no rebates or drawbacks, and no free passes for shippers or agents.

Milk Cows have been in light demand, and in moderate supply. All that were offered found buyers at \$40 to \$70 per head. Calves.—The market for calves has ruled steady throughout the month, and closes fair with prices a fraction lower than last week. Grass calves are now coming in, and bring 40 to 50 c. per lb. Ordinary to good veals are selling freely at 7c. to 9c. per lb. Sheep and Lambs.—There has been a quick sale for sheep at good prices, and 4 1/2 c. to 6 1/4 c. per lb. is readily paid for fair to good. Choice lots sold at the close at 6 1/2 c. to 6 3/4 c. per lb. The large number of Kentucky and Canada lambs offered, weakened the market for this stock, and sales were slow at the close at 6 1/2 c. to 9 1/4 c. per lb., with 10c. for a few extra lots. Swine.—There have been no live hogs offered the past four weeks. All arrivals have been consigned direct to slaughterers. Dressed hogs have been advancing, and were firm at the close of the market at 8 1/2 c. to 8 3/4 c. per lb.

Sheep Raising in Nebraska.—M. Meyers, Gage Co. Neb., sends us the following report of his business last year, the fourth in which he has been shepherding in that State. He had 1000 sheep worth \$3,500 at the commencement of the year. His expenses were \$300 for 100 tons of hay; \$100 for 500 bushels of oats in the shed; wages \$250; washing and shearing sheep \$200; salt \$35; cost of shed \$50; 20 sheep lost \$70; total \$1,035. Produce 4,500 lbs. of wool \$1,800; 400 lambs worth \$1,000; total \$2,800. He considers it safe to look for a profit of 50 per cent in sheep raising in Nebraska.

SPECIAL PREMIUMS STILL OFFERED.

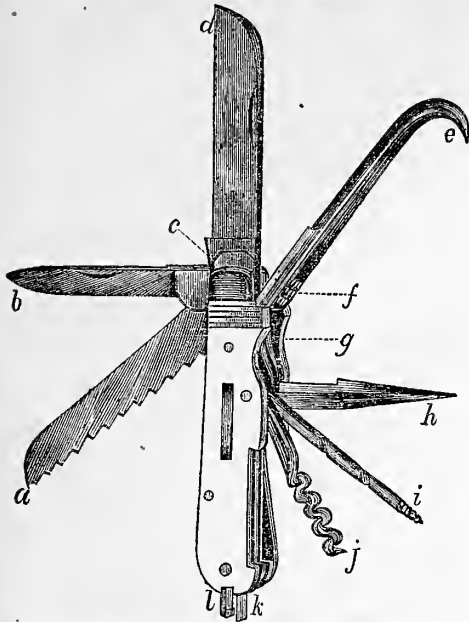

MULNUM IN PARVO KNIFE, OPEN—WEIGHT 2 OZ.

The General Premium List closed July 1st. The following Special Premiums are continued until further notice:

The Mulnum in Parvo Knife for 8 subscribers to *American Agriculturist* at \$1.50 each a year. (Knife sent post-paid.)

The Beckwith Improved \$12 Sewing-Machine for 10 subscribers to *American Agriculturist* at \$1.50 each a year.

The Beckwith Portable Family Sewing-Machine, price \$20, for 30 subscribers to *American Agriculturist* at \$1.50 each a year.

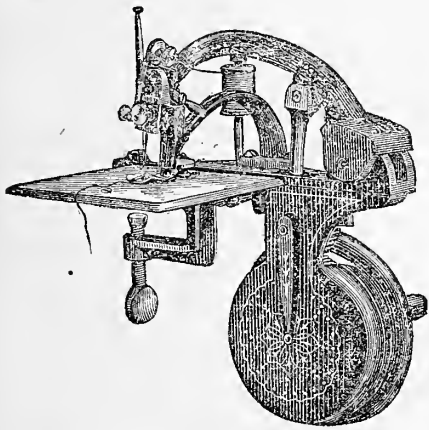

BECKWITH PORTABLE \$20 SEWING-MACHINE.

To secure the Chromo, mounted and prepaid, 25 cents must be remitted with each subscription for *American Agriculturist*.

N. B.—Two half-year subscribers in all the above cases may count for one full year in a Premium Club List.

Please tell your Friends
THAT THEY CAN SECURE THE
AMERICAN AGRICULTURIST
Six Months for only 75 Cts.

In order to enable many persons to become acquainted with this valuable Journal, who have not hitherto taken it, the Publishers will receive subscriptions for it for the

months commencing with July and ending with December, 1874, at seventy-five cents each. Will not each of our present subscribers speak "a good word" to friend or neighbor?—Please note: We will send the *American Agriculturist* for six months, beginning with July, 1874, for seventy-five cents. This offer, of course, does not include the beautiful chromo "Up for Repairs," which is offered to all yearly subscribers free, when taken at 245 Broadway, or twenty-five cents extra when sent prepaid. Give the paper a six month's trial trip, or better still, try it a year.

... P. S. ...

Better Still!
BEAUTIFUL \$5 CHROMO,
AND
Half a Year's Subscription,
ALL
For a Single Dollar.

Considering the hardness of the times, and in order to meet the wishes of a great number who desire to have our beautiful chromo, "**UP FOR REPAIRS**," but who did not feel able to pay the \$1.75 required to get it, the Publishers have decided to send the *American Agriculturist*, from July 1st to the end of the year, and to deliver, free of postage, a mounted copy of this beautiful **Chromo**, which has given so much pleasure, all for \$1, if promptly called for.

Please make this known to all your friends and neighbors.



containing a great variety of Items, including many good Hints and Suggestions which we throw into smaller type and condensed form, for want of space elsewhere.

Remitting Money: — Checks on New York City Banks or Bankers are best for large sums; make payable to the order of **Orange Judd Company. Post-Office Money Orders** for \$50 or less, are cheap and safe also. When these are not obtainable, register letters, affixing stamps for postage and registry; put in the money and seal the letter in the presence of the postmaster, and take his receipt for it. Money sent in the above three methods is safe against loss.

N. B.—The New Postage Law.—On account of the new postal law, which requires pre-payment of postage by the publishers, after January 1st, 1875, each subscriber, whose subscription runs over into the next year, must remit, in addition to the regular rates, one cent for each month over which his subscription extends in 1875, or ten cents for the whole year 1875. Every subscriber, whether coming singly, or in clubs at club rates, will be particular to send to this office postage as above, that is, at the rate of ten cents for the year, additional to the regular subscription. Subscribers in British America will continue to send postage as heretofore, for pre-payment here.

Bound Copies of Volume Thirty-two are now ready. Price, \$2, at our office; or \$2.50 each, if sent by mail. Any of the last seventeen volumes (16 to 32) will also be forwarded at same price. Sets of numbers sent to our office will be neatly bound in our regular style, at 75 cents per vol. (50 cents extra, if returned by mail.) Missi. numbers supplied at 12 cents each.

Our Western Office.—Our friends in the West are reminded that we have an office at Lakeside Building, Chicago, Ill., in charge of Mr. W. H.

Busbey. Subscriptions to *American Agriculturist* are taken there, and sample copies of the paper and chromo are delivered, and orders received for advertising on the same terms as in New York. All our books are on sale at the Western Office. Please call and examine, buy, subscribe, and advertise.

Catalogues and Reports.—Several of these must wait until another month, as our crowded columns will not allow us to do justice to them.

"The Acrobats."—Look at the figures of Crandall's Acrobats, on pages 316 and 317, the most amusing toys ever invented for children. A good laugh now and then, never hurts fathers and mothers any more than it hurts boys and girls.

About Manuscripts.—It has been decided in law that an editor or publisher is not responsible for a manuscript sent to him without solicitation. The English papers, and some of the New York dailies, give notice that no manuscripts will be returned. This rule is no doubt necessary in a daily, but as far as we are concerned, we endeavor to return unaccepted articles when stamps are sent for that purpose, but it is a little too much to expect us to pay 20 or 30 cts., for reading an article that we do not want—still some are so inconsiderate as to require this.

Nameless People.—We have said in almost every issue that anonymous letters would not be answered, and that matters of interest to the writer only, could not take up space in the paper. If "A Farmer's Boy that is fond of work and pleasure," had taken half the space required for that signature, to write his own, we should have sent him a catalogue of the machine he wants. As it is, his letter goes to the waste basket. The "boy" should learn while young that it is impolite to write any one an anonymous letter upon any subject whatever.... "Subscriber" in Suffolk Co., N. Y., can get our Onion pamphlet for 20c., but under our rules we can not answer his other matters. AGAIN we repeat, "sign your name." It will not be published if another signature is used with it, or a line is drawn across it.

Grasshoppers in Minnesota.—A serious calamity has befallen several of the newer counties of Minnesota; they have been visited by grasshoppers, in such quantities as to completely lay bare large districts, and by eating up every green thing, have brought much suffering, and even ruin in their train. Those who have never seen a district that has been devastated by this scourge, can form no idea of the completeness of the destruction. So sudden, severe, and wide spread has been this affliction that the Governor of the State has called for aid, both from the residents of Minnesota and from others. It is expected that the Patrons of Husbandry will extend some relief through their organization, but there will be plenty of opportunity for the exercise of benevolence by others. Food, or the money to purchase it, is the pressing want. Though the severity of the calamity will have been relieved, by the time this reaches our readers, there will still be a great need of food and seed for next season. Contributions may be sent to Gov. C. K. Davis, or Gen. H. H. Sibley, St. Paul.

Other Basket Items on page 315.

SUNDRY HUMBUGS.—The honesty of farmers as a class is proverbial, and being simple-hearted and honest themselves, they are slow to suspect others of dishonesty or wrong intent. Hence it is that humbugs and swindlers of all kinds find their most numerous dupes among agricultural communities, and a list of the names of the well-to-do farmers in every thriving section of the country is something that these sharpers are willing to pay well for. And circulars of all kinds, from those of counterfeit money vendors to the latest quack-medicine maker, find their way to the post-offices in every rural district. Besides these general humbugs, there is a class relating particularly to matters connected with farming, which we may class as

AGRICULTURAL HUMBUGS.

We have exposed from time to time the tricks of the rascally vendors, who sell farm-machinery, and take notes which are so ingeniously worded, that the buyer finds his name affixed to a very different document from that he supposed he had signed. One of the minor annoyances, not only to farmers, but to every one who lives in the country, are

THE LIGHTNING-ROD MEN.

These glib-tongued fellows delight to find only women at the house, for they think they can soon so work upon their fears, as to make them feel that their safety not only depends upon having a lightning-rod, but the par-

icular style offered by that vender. It is often difficult for a man to get rid of one of these fellows, and it is seldom that a woman is sufficiently resolute to clear him out. A lightning-rod, properly put up, is no doubt a protection, and the simpler this, the better. All these twisted and fanciful styles, insulations, and complicated points are useless, if not worse. Platinum points can be obtained in any large city, and if one chooses he can put up a rod himself, without the aid of others. Some of these lightning-rod fellows are not only nuisances, but swindlers, and make the job cost much more than the estimate. We have received numerous complaints of this kind. The following comes from Baltimore Co., Md.:

"I enclose a card representing a lightning-rod company; they have been operating in this county in the following manner: A salesman precedes the wagon, stating that they are selling on a different plan from other companies, that is, so much a set, (\$17.50 per set of 40 feet); the next day an agent with the wagon and a workman comes along, and after putting up about 100 feet of rods and two points, they modestly present their bill in the following form: 100 feet, @ 42¢ per foot, two points, @ \$3 a piece, two supports, @ \$1 a piece. One thing is certain, if they stay much longer about here, they will be 'rodded' themselves."

In all such cases agree upon the amount of work to be done, and the price beforehand, and don't be bullied into paying any more. . . . Every farmer and breeder of animals would be very glad if he were able to produce male or female progeny at will. A chap in Brooklyn has advertised that this could be done, and offered to send the secret for the moderate sum of \$1. One of our friends sent the dollar, and received, written on half a sheet of note paper, the following: "It has been discovered in Germany, that if you give the male at the first signs of heat, you will produce females, and if at the end of heat, males. This plan was tried by Prof. Thoy, and has always succeeded. Yours, J. L. Clark."—Now this was "discovered" we can not tell how long ago, but quite long enough for its fallacy to be proved, and as it was published in all the agricultural papers of the day, we consider the selling of this, which is no secret at all, as a first-class agricultural humbug. . . . While we are always ready to denounce any fraudulent attempts by persons pretending to have patented articles, that have been long in use, or otherwise not patentable, we do not see how we can help our correspondent in Buchanan Co., Iowa. If the claimant has a patent for the clevis, the law is on his side, and from what we at present know of the case, we should advise those who have infringed, to compromise the matter. . . . Letters continue to come in relation to the

CHEAP SEWING MACHINES.

We have in several previous numbers said all that is necessary about these. We need only add that we continue to receive complaints of a concern in Canal st., and advise extreme caution. Here is now the "Hope Manufacturing Co.," advertising a \$5 machine in the Western papers; the publishers send their little bills, and get no money for advertising. As the "Hope Manufacturing Co.," give neither street nor number, we think it a very good concern to be shy of. People engaged in a straight forward business, like to have their whereabouts known, and the withholding of it is sufficient ground for suspicion. . . . The non-explosive-anti-chimney-breaking-powder man, has been to Seneca Falls, N. Y., he tried his little game in a family where the *Agriculturist* is read, and all that he made was the privilege of paying for a broken chimney.

A DANGEROUS HOTEL.

We advise strangers not to go to the Arcade Hotel, even if they can find such a place. Another death has taken place there. This time it was one Michaux; Callinwater, landlord, wrote to surviving friends in N. C., and the whole story as given in these columns in June last, was repeated. Is it possible that so transparent a trick as this can catch anyone?

THE DEALERS IN "QUEER,"

Those who are called who offer counterfeit money, have presented so little novelty that we have not given them much attention of late. Their business must have diminished greatly, since they are by law deprived of the use of the mails; besides this, other papers have at last taken the matter up, and exposure has been so thorough, that only the foolishly wicked can be caught in the trap. We have at last two new circulars instead of the old form that became so monotonous. B. M. O'Neill, who is one of the hundred or more engravers, who were in the employ of the U. S. Government for ten years, and "superintended the engraving of all the plates for the United States money," prints from plates he has engraved since, but he is quite beaten by J. D. Falkman & Co., who offer "greenbacks struck off from the original plates, which were supposed to have been destroyed" . . . A good honest soul in one of the Southern States received one of these "confidential circulars," and being horrified at the iniquity of the thing, devised a plan by which he proposed that we could, with the aid of a detective, catch the man who sent the circular. In the innocence of his

heart he supposed that the sending of such a circular would be sufficient to lead to punishment if it could be proven. But nothing short of the possession of counterfeit money would lead to conviction, and that these chaps take good care not to have. As we have said before, in all this offering there is probably not a counterfeit bill at the bottom of it. The fellows offer to send the *queer* by express; they may send a box of old paper, saw dust, or some such stuff in return for the money, but no counterfeit bills. They are too shrewd to have anything to do with such dangerous stuff. They know that the fool who has sent \$25 in good money in the hope of getting \$200 of counterfeit, will not dare to "sneak," as he will then show that he was ready to become a partner in a felony. They must now and then come across a weak minded, or really dishonest, avaricious chap, who will bite at their bait, or the thing would not be kept up even at its present slow rate. We should judge that there are not five of these circulars sent out now, where there were a hundred before the passage of the law, excluding them from the mails.

MEDICAL MEDLEY.

A subscriber in Conn., seems surprised to see quack medicine advertised in a religious paper! We regret to say that religious papers as a class, are the most active agents in the spread of quackery, and we frequently see advertisements in them that even the city dailies, which are not at all careful in such matters, would hesitate to publish. These dealers in quack medicines are well aware that not one reader in a thousand, knows how little the editors of these papers have to do with their management. As a rule the publishers of these papers pay less regard to the character of their advertisements than any others, but the editors are not responsible for this. It is an unfortunate state of things, and the only remedy we can suggest, is for the readers of these papers to inform the publishers, that unless they reform their ways the paper will lose patronage. If the publishers can be shown that it is to their pecuniary interest to leave out this vile quackery, they will do it, but no appeal other than to their pockets, is likely to have any effect. . . . "Uncasville." It is very kind that "Preacher of the Gospel" to offer to send the prescription which cured his son of consumption. It is one of the oldest of tricks, and has been frequently exposed. The prescription will be found to contain ingredients, which can not be obtained in "a proper degree of purity" if at all, at the drug stores, and the advertiser, taking pity on suffering humanity, has at great trouble and expense procured the right stuff, which he will furnish "at cost," which is usually anywhere from \$2 to \$5. This is very old and stale, but must bring in some dollars or these "retired physicians" and "returned missionaries" would not keep at it. . . . The makers of "eye-cups" are industriously advertising them, and we are surprised to see that the horticultural magazines, which have usually kept very free from all doubtful advertisements, publish eye-cups, lotteries, and dubious sewing machines. These eye-cups are appliances, which pretend to change the convexity of the eye. Now admitting that they could do this, but very few troubles of the eye depend upon any mechanical defect, and the use of these cups may prove highly injurious. We repeat our caution, do not tamper with your eyes either by using these, or in any other manner. . . . In looking over the stock of humbug-literature that accumulates every month, we now and then come across an old customer, that has been disposed of years ago; we were quite amused to find this month an inquiry about E. P. Huyler and his "Wine of Apocynum." Our friend H. T. H. will find the question "What of him?" sufficiently answered in these columns in December last. He is the same as "Old Mother Noble," and is the "Electric Health Restorer" man, also the Dr. Clark of "Indian Blood Syrup" notoriety, and we know not what besides. . . . By the way, we notice that "C. Johnson, M.D." is sending out threatening letters by his lawyers. But then the man at the bottom of this Indian Blood business is E. P. H. . . . With all these things of greater or less antiquity, it is refreshing to have now and then a

"MEDICAL" NOVELTY.

Once in a while we can get a laugh, as out of Dr. Churchill's "Restorative Remedies," for which a Cincinnati house, calling themselves chemists, send out prescriptions, and say how they are prepared, but as "unprincipled druggists" "never prepare according to our method of preparing," all the patient can do is to send to the Cincinnati house, and get the genuine thing. As one of the directions is to "heat on a slow fire in a covered vessel to 100 degrees specific gravity," it is no wonder that "unprincipled druggists" fail. Yet these chaps call themselves "Pharmaceutical Chemists." . . . But the richest thing of late is the pamphlet, setting forth the virtue of Dr. J. R. B. McClintock's "Dandelion Anti-Bilious Pills and Bitters." We thought the narrative of our beloved Ned Eastman was some, but that is as much behind Mc's pamphlet, as a Comanche Indian is inferior

to a Philadelphia quack-doctor. This Dandelion stuff is nothing short of the very thing with which "the emperor, his family, and his poorest subjects" are physiced. Why was Alexis, when he visited us, so attractive to American ladies? Why was the Emperor's daughter so lovely that the Duke of Edinburgh chose her to be his duchess?—This pamphlet does not say so, but we haven't the least doubt, that it was all due to Dandelion. It happened in this way, Doctor Mac "had heard of the great reputation acquired by Dr. Micheleleski, the chief physician of the Emperor Nicholas, from his wonderful cures by the use of a preparation of Dandelion, the composition of which was only known to himself." Now while there is the best College of Pharmacy in the country, and one of the oldest and best medical schools in Philadelphia, there was no one there who could get the "virtues" out of a Dandelion root, so McClintock J. R. B. sent all the way to Russia, to find how to do it. The account of his friend, Dr. G.'s visit to Russia, and his interview with old Micheleleski, is just touching. The Dandelion cures people who have been knotted, and the accounts of the whipping of women, and "pictures to match," are justly styled thrilling. Indeed, the account of this medicine is one of the choicest specimens in its class of literature, and while the engravings of licking and hand-cuffing half-naked women do great credit to the Philadelphia artist who designed them, we think that the picture of Dr. Micheleleski, drinking "the health of Dr. McClintock in Dandelion Bitters," is a masterpiece. The whole thing is very funny, and as to the virtues of the stuff, if there is any disease that this won't cure, if we believe the pamphlet, it must be a something we shouldn't like to have. Take this pamphlet, and the lithographed appeal to agents together, and they form gems in our collection of humbug literature, with which we would not willingly part. And yet, sad to say, there are even in this day of free schools and general intelligence, persons who will believe this balderdash, and what is worse, spend their money for stuff thus ridiculously set forth. J. R. B. McClintock may go to the head.

The Practical Farmer, published in Philadelphia, by Paschal Morris & Son, is now the only agricultural paper in Pennsylvania, it having absorbed the *Journal of the Farm*, published by Daniel Baugh.

The Death of Mr. Olm.—M. Olm, of the senior of the firm of Olm Bros., florists, Newark, N. J., met with a very sad and sudden death on Sunday, June 28th, as he was about to take his family to church. His brother, who was at a distance, saw him upon the ground holding the reins and trying to check the horse, which had taken fright from some cause; by the time his brother could reach him, Mr. Olm was senseless, the foot of the horse having struck him a blow upon the head, which caused his death in a few minutes. The children, who were in the wagon, were injured, but not seriously. Mr. Olm was about 45 years old at the time of his death. He was born at Luxembourg, and came to this country about 1860, having abroad acquired a high reputation for the tasteful arrangement and management of grounds. For a few years after his arrival he was gardener for Mr. Judd; he was also with Messrs. Parsons & Co., of Flushing. He afterwards established himself with his brother at Springfield, Mass., and when land became too valuable for gardening purposes, they sold out and removed to Newark. His sudden death occurred just as the new establishment was fairly in working condition.

Wool Waste for Manure.—Our correspondent, "G. P. D.," Philadelphia, who kindly furnished the information as to the value of wool waste as manure, again writes that the waste was used upon about 18 acres of land, and that the present season the crops growing upon the 18 acres, including the grass, are looking "tip top," and that he is satisfied that wool waste is an excellent manure. (Being rich in potash and nitrogen, it is a fertilizer of too great a value to go to waste.)

The Wisconsin Rail-Road Decision.—The recent decision that the Legislatures which charter rail-roads, have the right to make laws to govern their charges for transportation, has occasioned much comment. While some look to it as a step toward abolishing exorbitant charges for the transportation of produce, others regard it as a death-blow to further rail-road development in the State, and that the people of Wisconsin must content themselves with the facilities they already have, as capitalists will not invest in rail-roads, while the present laws are in force. The case goes to a higher court for affirmation or otherwise, and the decision is not regarded as final. In the meantime if the managers of the roads, and those who make use of them, can be made to see that their interests are identical, and that the matter had better be settled at once, as it will ultimately be, with a regard to the rights of all parties.

The Patrons of Husbandry in Ohio have availed themselves of the general corporation laws of the State, and stand on the records as a regularly incorporated body, "The Ohio State Grange of the Patrons of Husbandry, for the promotion of agriculture and the mutual benefit of those engaged in the purchase and sale of stock, commodities and articles pertaining thereto, including household luxuries." This places the State Order on the business footing of other corporate bodies.

The Swiss Colony, which located in the Tennessee mountain region six years ago, has made a fair record as an agricultural community. There are in the colony 325 inhabitants, living in 78 houses. They have 7,600 fruit trees, 4,700 grape vines, and till about 1,000 acres of land. They have two schools, and have established an Agricultural Society. The growth is not like that of communities on Prairie railroads, but it is growth, nevertheless.

A Colorado Sheep Farm.—Mr. John Sheldon, of late a large sheep farmer of New York State, has commenced sheep farming in Larimer Co., Colorado. He has 500 acres of land, upon which he has made an artificial lake of 40 acres, which he has surrounded with planted shade-trees. He has already brought three carloads of pure Merino sheep to the farm. The celebrated ram "Dictator," which has yielded 26 lbs. of wool at a shearing, is at the head of his flock. Mr. Sheldon proposes to put 10,000 Mexican ewes upon the range.

Crop Prospects.—Advices from the great corn-growing States of the West represent that, although there were many interruptions to corn-planting in May, the seed went into the ground in good time, and under circumstances ordinarily favorable. Letters received as late as May 29th, report favorably as to winter and spring wheat prospects, and enthusiastically as to fruit prospects.

St. Joseph and Denver City R.R. Bonds.—Those of our readers, who hold any of the above bonds, are informed that the U. S. Court, held at Leavenworth, Kansas, has appointed a "special master" to report the amount of interest due and unpaid. In order that this may be done, the bonds and unpaid coupons should be deposited at once with The Farmers' Trust and Loan Co., the trustees under the mortgage, at 26 Exchange Place, New York. As soon as the deposit has been made, measures will be taken to purchase the property for the bond holders.

A Mule with a Colt.—A Pepper, Franklin Co., Ind., writes that a mare mule owned by a neighbor has recently had a horse colt, which it suckles and cares for the same as any other mare would. (Such an occurrence is rare, but happens, occasionally.)

Connecticut State Board of Agriculture.—We have received through Secretary T. S. Gold, the reports of the Connecticut Board of Agriculture for 1873. These reports increase in interest and value year by year. Undiluted by the useless tables of figures usual in such reports, this volume is filled with practical matter; papers and discussions upon matters of every day interest to the farmer, by men who gain their living in the field as well as by those who are eminent for their scientific attainments. It is one of the best of the few agricultural reports which it will pay to procure, to study and to keep for future reference.

The Butter Convention.—The National Convention of Buttermakers and Dealers, met at Indianapolis on the 17th of June. The principal address was made by Mr. D. W. Dake, of Beloit, Wis. We are unable to find space for this valuable address, but it will doubtless be published in full in the final report of the proceedings. It is worthy of careful study. A large number of essays were offered in competition for the premium of \$1,000 liberally offered by Mr. Dake.

How to Use Bones.—"P. A. D.," Lexington, Va. Powdered or crushed bones are useful for any crop. They add to the soil phosphate of lime chiefly, and this is a component part of nearly every vegetable valuable for food. They are of special value for turnips, potatoes and grass.

Tan-bark for Stables.—"P. A. D." Leached tan-bark makes a very clean and cool bedding for horses, but it should be dried before it is used. If used while wet it ferments and heats, and will cause the hair to fall from animals that are bedded with it. At least such has been our experience with it. Sawdust is the cleanest bedding for horses that we know of.

Artificial Ponds.—"F. L. T.," Winnebago Co., Wis. Gold-fish will live in an artificial pond,

if there is plenty of water kept in it, although there may not be a stream running through it. But trout will not. To make such a pond, it is only necessary to dig out the earth and raise a dam to preserve the supply of water. In digging the pond, it is well to make some deep holes in the bottom, and not to have it all the same depth.

Mapes' Superphosphate.—"H. M.," Bergen, N. J. One superphosphate, honestly made, is as good as another. The process is such, that the amount of soluble phosphoric acid is, or should be, about the same in all superphosphates. As regards the above-mentioned fertilizer, we can say that the manufacturer of it, Chas. V. Mapes, has an excellent reputation, and is trustworthy, and that is the main point to be considered in purchasing a fertilizer.

Railway Horse-Powers.—"V. W. K.," Shirland, Ill. There is not much choice as to railway horse-powers when made by reputable makers. The principle involved in their construction is nearly the same in all of them, and the chief point in selecting is strength and excellence of construction. There are several described in the advertising columns, either of which would be desirable machines.

Flatulence in a Horse.—"D. P. M.," Newark, N. J. Flatulence, or the discharge of wind, is a symptom of indigestion. It should be remedied by feeding easily digested food, such as hoiled oats, or scalded cut-feed, with ground oats and bran, and a pound or two of linseed meal. An ounce of salt should be given with each feed. A few carrots, or hoiled potatoes, would also make a useful addition to the feed.

City Street Manure.—"S. F. K.," The sweepings of the streets of towns and cities are mixed with so much earth and rubbish, that their value is much less than good stable manure. But they have the advantage of being free of weeds. The urine, which is so valuable a part of stable manure, is not contained in the street sweepings. At \$11 per cord for stable manure, as usually estimated, street sweepings should not be worth more than \$3. Peter Henderson, an excellent authority, and who has used them extensively, speaks very highly of them for garden purposes.

Hail and Horticulture.—Some of our friends, who live in the northern part of Bergeen Co., N. J., suffered severe loss from the hail-storm of July 4th. The hail-stones were so large as to break not only glass, but sash, and do other damage. Greenhouses were demolished, and fruit-trees not only stripped of their fruit, but their leaves. Unless one has witnessed the effects of such a storm, he can have little idea of the destruction it carries in its path. Several years ago we were at Rochester, just after the nurseries of Ellwanger & Barry had been crossed by one of these hail tornadoes. It was a sad sight. . . . Since making note of the above, we learn that the great Rose Show, announced for July 3rd, at Lyons, France, is postponed until September, on account of a great hail-storm, which injured not only roses, but other vegetation, and destroyed the grape and other crops of a wide region.

Packing Eggs for Hatching.—"L. M. A.," Toledo, Ohio. The best material for packing eggs is oats, and wheat chaff is nearly as good. Finely chopped straw is also a good material, but hay and sawdust are very poor material. The common idea that eggs are injured for hatching by transportation, we do not believe. We have raised a large number of fowls from eggs taken from barrels, in which they were packed with oats for market, and which had traveled over 1,000 miles with rough usage on the way. The losses were inconsiderable.

Death of a Duchess.—The two-year-old heifer, 7th Duchess of Oneida, which was purchased by Mr. A. J. Alexander, of Kentucky, for \$19,000, at the New York Mills sale, last fall, has recently died of pneumonia. This death, with that of the cow 8th Duchess of Oneida, which sold for \$40,000, shows what great risks breeders of this class of stock are willing to run, and that these great prices do not represent all profit.

The Lock Nut and Bolt Co.—"W. W." The address of the manufacturers of the lock nuts and bolts, described in the *Agriculturist* some time ago, is 17 Dey-st., New York. It was formerly 61 Broadway.

Is Flax an Exhaustive Crop?—"N. T. S.," Lincoln, Neb. Flax is considered as an exhausting crop, and justly so, when we know that the seed contains twice as much potash and phosphoric acid, and twice as much nitrogen as wheat, while the straw is still more exhaustive of these valuable constituents of the soil, than wheat straw. A soil that would produce six

successive crops of wheat, will bear only three of flax, even when the straw may be returned to the soil.

Blight—Tiles.—"J. Q. A. M." The blight in fruit trees is still an obscure matter, the sudden death of a tree, or a part of it, being usually the first intimation that there is any trouble. The evidence thus far obtained points to a fungus of some kind as the cause, but as yet very little light has been thrown upon its prevention. . . . Clay that makes good brick, will also serve for making tile.

Value of Sawdust.—"G. R. W.," Boonville, Ind. Fresh oak or green sawdust is worth nothing as manure, in fact, it is not manure at all. It is of the most value when made to absorb the liquids from stables, it then rots very readily, and not only makes a convenient vehicle for the liquid manure, but is of some service itself. If we had a large quantity, which cost nothing, and could be cheaply hauled, we would pile it in large heaps and burn it, and use the ashes. In this way it would be of immediate and considerable value for any crop, but especially for grass.

Pea Bug.—"W. G.," Ottaway, Ill. The beetle deposits its eggs on the very young pod, and the minute grub eats into the pea, feeds, grows, and changes into a beetle; the entrance is so small that the growth of the pod obliterates all marks. Unless all in a neighborhood will agree to plant no buggy seed, we do not know how you can be clear of them.

Indefinite.—"J. R.," Schley Co., Ga. Your question is too indefinite, and had you signed your name, as every one should in writing to any one, especially to editors, you would have had a letter asking explanations, and saved us the trouble of printing this. Will not our friends be kind enough to remember that no merchant, banker, or other person in business does his correspondence by initials, and that business with editors should be done in a business-like manner.

Preserving Eggs.—"J. O. B.," Newark, N. J. The most successful known method of preserving eggs is to smear them evenly with boiled linseed oil and pack them with the small end downwards in plaster of Paris or salt. It is doubtful if they can be kept fresh in large quantities for so long a period as 7 months, although they have been kept 6 months in small quantities.

Preserving Posts.—"R. F. S.," Yellowstone, Wis. It is sufficient if fence posts are soaked in lime water for twenty-four hours, if they have been well seasoned previously. If they are green, forty-eight hours soaking should be given. A convenient way is to have a large hogshhead half full of lime water and fill it with posts standing on their butt ends, and change the posts every day or two days until the whole are soaked.

Poultry or Stock Dealers.—"W. O.," St. Paul, Minn. We can not give the names of dealers in poultry, eggs, or stock for very obvious reasons. The names of parties dealing in these things are to be found in our columns appropriated to such matter, and no person's name is admitted there if we know or have any reason to suspect that he is not trustworthy. Persons who desire to purchase, perhaps could not do better than select those dealers who are most conveniently situated for the purpose.

Yield of Root Crops.—"J. C. P.," New Orleans. A fair crop of mangels would be 600 to 800 bushels, of ruta-bagas about 600 bushels, and of sugar beets 400 to 500 bushels. Much larger crops are frequently raised, and double the quantities mentioned sometimes, but only in rare instances. It is safe to discount reports of unusually large crops of anything.

Hollyhock Disease.—The Hollyhock fanciers in Europe are in trouble. A mould or fungus, *Puccinia malvacearum*, proves exceedingly destructive to the plants. It was first noticed in Bordeaux in April, 1873, since which time it has spread rapidly through France and Germany, and has already appeared in England. The only proposed remedy is to destroy all the plants of the mallow family, hollyhocks included, and give it nothing to feed upon.

Grain Weevils.—"J. C. B.," Allentown, Pa. Barns are not readily freed from weevils on account of the difficulty of reaching all their hiding-places. But granaries are more easily rid of them. The walls and floors should be washed with hoiling water or potash lye, and every crack thoroughly explored with a stiff broom dipped in it. Then the walls should be whitewashed with a thick coat put on while hot. The windows should be covered with fine wire gauze to keep out all insects.

A Lame Colt.—"M. T.," Parma, Mich. A sprain of the shoulder nearly always results in a contraction of the muscles. The depression thus caused, is called by some people "sweeny." It is, however, simply the result of the sprain. If it has been severe, and inflammation of the deeper muscles has occurred, the injury should be attended to at once, by a competent veterinary surgeon. If only superficial, a brisk application of some exciting liniment, with rest, and food of a cooling character, such as bran mash or carrots, might remove the lameness.

Vitality of Eggs.—"T. P. L.," Essex Co., N. J. The vitality of eggs is effected by evaporation, more than by moderate cold or heat. If kept in a dry, warm place, the moisture rapidly escapes through the porous shell, and the egg is spoiled. They may be kept for hatching for a month without injury in a cool cellar, if they are occasionally turned. It is always safer, however, to set only fresh eggs.

Learning to Farm.—"J. W. P.," Pittsburg, Pa. One cannot learn much about farming in less time than a year. The routine of the work on a farm is not complete in less than a year's time. Whether one year or more would be necessary, depends on the aptitude and industry of the student. It would be best for those who want an opportunity of learning the business, to seek a good farmer and pay him for his trouble. It is not of much use to study books until you know what you want to learn. A little experience on a farm will teach that, and then it is an easy matter to get the books which may be needed.

Emigration to Virginia.—"W. A. M.," Windsor, Nova Scotia. There are many favorable points in the Piedmont region of Virginia, for profitable farming. The neighborhood of Charlottesville, has the advantage of good soil and climate, and markets, and the vicinity of a University. It would be well to visit the country before making a determination to move.

Stable Floors.—"A Subscriber since 1845." A stable floor made of cobble stones, cement, and tar, is described in the *Agriculturist* of November, 1873. The size of the stones is immaterial, small ones will make as good a floor as large ones, if the foundation is solid, and they are well rammed down. The ditch behind the cows should not be so deep as 8 or 9 inches; 4 inches is enough and 6 should be the extreme depth. If no cement is used, and only coal tar, the spaces between the stones should be filled with sand, and as much hot tar poured in as the sand will absorb. Then sand should be thrown upon the floor, and rammed down or beaten until it is no longer soft or sticky.

Ground Bones.—"L. E. B.," Toledo, O. Ground bones retail in England, at \$30 to \$45 a ton in gold. The price in New York and other centers of the trade, is about the same in currency.

A Cribbing Horse.—"J. W. G.," South Middleboro, Mass. The only satisfactory method of preventing a horse from cribbing, is to make him wear a muzzle, or remove every thing from the stable that he can lay hold of with his teeth. A muzzle for a cribber was described in the *Agriculturist* for October, 1872, and a movable manger which turns outside of the stall, in November, 1872.

The best Breed of Sheep.—"A. N. T.," Norwalk, Ct. For a good, stony pasture in New England, the Cotswolds would probably be the best sheep for wool and mutton. The grades of this breed grow to a good size, make large early lambs, yield a good carcass of mutton, and have a heavy fleece of a fair quality of combing wool. We consider the grades more profitable to keep than the pure-bred sheep.

Books on Sheep and Horses.—"A. N. T.," Norwalk, Ct. The best book on sheep for general use, is "Morrell's American Shepherd," price \$1.75, although it is old and somewhat out of date. The best horse-book is probably "Stonehenge on the Horse," price \$2.50, (or \$3.50, English edition). Both may be had of the Orange Judd Company.

Value of a Merino Ram.—"J. T. F.," Lincoln, Neb. Whether or not it will pay you to expend \$25 for a pure Merino ram, depends on the quality of the ram and how it is used. If the ram is a good specimen of the breed and over two years old, and is well fed, he will be able to serve at least 50 ewes annually for 5 years. If the produce is such that the fleece is improved in value 10 cents a pound, and in weight but one pound by the first cross, which is probable, the cost of the ram

will be more than repaid by one year's service. The second cross will add more still to the value of the fleece. The value of any pure-bred animal should be calculated in a similar way, and it will be generally found that there is a large margin of profit in the first year's use, without counting the future returns.

A Furnace for Wood.—"W. W.," Clinton Co., Pa. For warming houses in country places, where wood is the only available fuel, the Gothic wood furnace, made by A. M. Lesley, 224 West st., New York, will probably be found the most convenient. It takes wood four feet long, and is of the simplest construction. It may be fixed in the cellar, and obviates the necessity of having stoves throughout the house.

Lands in Eastern Virginia.—"C. F. S.," Guernsey Co., Ohio. By writing to General Imboden, the State Commissioner of Immigration, Richmond, Va., you can get information as to lands for sale, or for colonizing purposes. Considering the large quantities of land for sale, and the number of persons always wanting to purchase, it would be well that those seeking purchasers should do so through our columns.

Devon Herd-Book.—Another volume of the Devon Herd-Book is in course of preparation. Pedigrees for inscription are now being received by the editor, H. M. Sessions, of Wilbraham, Mass.

Gypsum in Virginia.—"G. C.," Swoope's Depot, Va. It would not pay to procure gypsum from New York so well as from your own State. There are large beds of the purest varieties at Wytheville in Southern Virginia, owned and worked by a Mr. Matthews, of that place, from whom a supply could probably be procured at very low rates.

Stone Drains.—"G. W. W.," Bedford Co., Pa. In the *Ogden Farm Papers* for July the subject of stone drains is clearly treated. If stones are plentiful and handy, and tiles can not be procured, there are cases which may be exceptions to the general rule, laid down in the article referred to. A stone drain may be laid so as to be permanently useful, but it very rarely is.

Parrots.—A correspondent in Indiana wishes to know something about the treatment of parrots. If any one knows what to do with "Polly," except to give the often repeated "cracker," which she is supposed continually to "want," let him speak.

The R. I. Society for the Encouragement of Domestic Industry sends us its Transactions for the year 1873. We would especially call attention to a feature, which other societies may profitably adopt—its obituary notices of deceased members. These are remarkably full and accurate, and will in time be of historical value. The Society this year unites with the New England Agricultural Society in a Fair, which will be held at Narragansett Park, near Providence, on the 2d to 4th of Sept. next. This is one of the best fair grounds in the country, and the two societies should present an exhibition, which will draw as many visitors as the abundant means of communication with Providence can carry. The Rhode Island Society is a very old association, but the infusion of young blood has awakened it to renewed usefulness, and it has only to take pity on those who have occasion to write or print its title, and adopt a name that bears some relation to the size of the State to insure its prosperity. "The Rhode Island Industrial Society" would express everything that the present name does, and not exhaust the resources of the printing-office every time it was set up.

The Carpenter's and Builder's Guide, by Peter W. Plummer, is a hand-book for workmen, but is equally useful to any person who, desiring to build, would first sit down and count the cost. It contains forms of builders' contracts, a variety of tables of timber measure and other useful matter. Supplied by the Orange Judd Company, for \$1.00.

Irish Farming.—"An Introduction to Irish Farming," by Thomas Baldwin, Superintendent of the Agricultural Department of National Education in Ireland, has recently been published by Maemilian & Co., New York. It is a useful little hand-book of agriculture, which, although intended to relate more particularly to farming in the moist climate of Ireland, is yet full of information as to the management of soils, manures, crops, and stock, which may be useful to a young farmer anywhere. It is sold for 75 cts., and is worth more money.

Fruits and Vegetables.—"D. R. S. S.," Ohio, revives the question, "are tomatoes fruits or vegetables?" We have said our say on this in previous

years. Botanically speaking, they are fruit. In the seedsman and gardener's view they are vegetables. There is no satisfactory definition of the terms fruit and vegetable as popularly used.

How Books Sow Seeds.—We have frequent evidence of the wide-spread influence of good books on agricultural subjects. Often a single volume, going into a remote neighborhood, carries with it an idea that becomes of more value than would suffice to pay author, printer, and binder, for a whole edition. An instance of this has just come to our notice. A correspondent in Point Pleasant, Mason Co., West Virginia, says: "We have a tile-factory here, on this side of the river, owned by Mr. I. W. Smith, and as it may interest you, I will tell you that he got from you a copy of Waring's 'Draining for Profit and Draining for Health,' and tried a field that was very swampy and wet, to see what tile-draining would do for it. He followed the advice given in the book for laying out the drains, etc. It was such a great success, that he went into the business of making tiles for himself and for his neighbors. He has now more orders than he can fill."—Who shall estimate the benefit done to that neighborhood by this single book, costing a dollar and a half? It has increased the value of that region for all coming time.

Effect of Clover.—"G. R. W.," There is nothing in clover pasture that could prevent a mare from becoming in foal. If she fails to breed, there is some other reason than the nature of the pasture.

Onion Grub.—"O. C. H.," Conn. The small white grub you find at the 2d or 3d weeding is the larva of the onion fly—a serious pest when it is abundant, and one for which no satisfactory remedy has been found. The use of the manure you mention has probably nothing to do with the occurrence of the grub, as it results from an egg deposited by a fly, about half the size of the common house-fly, upon the stem of the plant above, though near the surface of the soil.

A Doubtful Case.—"Enquirer," Marlboro, Mass. We should hesitate to advise a man with a young family, and possessing but \$800, to buy a farm in the East, which is most likely badly run down, for \$3,000, in the expectation of making a living and paying for the farm out of the crops. There are some men who might succeed, but these are very few, and the probabilities are very much against a success. We should also hesitate very much to advise such a person to go West, if he can make a living where he is at a mechanical trade. Although a soldier's homestead can be procured for nothing, yet the care of a young family would be a serious burden in a new unsettled country to a man with such scanty capital. The far West is for enterprising young men without families, or older men with plenty of help, or for persons with money sufficient to carry them over the unproductive period. A worn-out farm in the East requires money and skill to restore it, and skill is a greater necessity and a rarer possession than money.

Sebastopol Geese.—"R. M. C.," Greenville, Tenn. We do not know the address of a breeder of Sebastopol geese. Probably inquiries addressed to some of the poultry breeders, whose names are found in our advertising columns, would elicit the information.

Rye for Winter Pasture.—An instance of the value of rye for early spring pasture comes to us from Kansas. Mr. W. B. Akers, of Douglass Co., needing some early feed for his large stock of mares and colts, sowed 120 acres of rye last fall. In the spring, feed was very scarce, and hay was worth the extreme price for Kansas of \$16 a ton, and corn 75 cents a bushel. The pasture thus fortunately provided saved an otherwise necessary outlay of \$2,500.

Farm Students.—"M. B. W.," Chautauqua Co., N. Y. A farmer who is competent to instruct pupils thoroughly in the art of farming, is not likely to take a young man who desires to learn the business, and pay him good wages. A farmer of our acquaintance, who has always one or two students, and who refuses many applications for more, receives \$300 a year, and the services of his pupils. The pupils are bound also to obey all his orders, and do any farm work, when and where he may require it, just the same as a hired man. This is absolutely necessary, for a farmer, before he can know how to command men, must know how to work himself. In return for the above payment, and their constant and industrious labor, the students receive their board and instruction. It is in fact an apprenticeship for whatever term may be desired, not less than a year.

See Page 313 for other Basket Items.

Improvement in Handling Cotton.

—By a new process, which has been sufficiently tested to show its practicability and value, the seed-cotton may be taken from the field and, without the use of the gin, brought directly to the card. Here a machine known as the Clement attachment, which occupies the position of the usual "licker-in," takes the cotton and cleans it from the seed, dust, trash, and notes, and delivers it in an tangled condition to the card, from which it emerges through the "doffer" in a continuous roll called a "sliver." This improvement in the manufacture of cotton will be of great benefit to the Southern planters, as it makes the use of the gin and the press unnecessary, so soon and so far as the manufacture of yarns direct from the seed-cotton can be established. Then the natural connection between the planter and the spinner will be effected, and instead of the raw material being exported, a partly finished product, the yarn, will be. Mr. F. E. Whitfield, sr., has several of these machines already in successful operation at Corinth, Miss.

State Fair Notes.—As the Ohio State Fair is to be held at Columbus for a number of years, the Board has taken possession of the County Fair Grounds east of the city, has extended them, and is making many permanent improvements. This subject of a place for the Fair has been a matter for heated discussion for ten years, and was settled in favor of location at the State Capitol, at the last winter meeting of the State Agricultural Society. The fair will be held the second week in September—Sept. 7th to 11th, and a special effort will be made by the dominant party, to have the fair all that the legitimate Agricultural Exhibition can be. The Northern Ohio Fair at Cleveland, will be held a week later, partaking more of the character of an Industrial Exposition. An effort is being made to organize a Southern Ohio Fair Association to hold a fair at Dayton.... The Indiana State Fair and Exposition, will open at Indianapolis Sept. 7th, and hold thirty days.... The Illinois State Fair will be held at Peoria, Sept. 14 to 19; Iowa at Keokuk, Sept. 21 to 26; Kansas at Leavenworth, Sept. 7 to 11; Wisconsin at Milwaukee, Sept. 7 to 12; Wisconsin Industrial Association at Mineral Point, Sept. 1 to 4; Minnesota at St. Paul, Sept. 8 to 12; Nebraska at Omaha, Sept. 29 to Oct. 2; Colorado at Denver, Sept. 22 to 26; California at Sacramento, Sept. 21 to 26; Michigan at East Saginaw, Sept. 14 to 19. The Industrial Exposition at Chicago, will open Sept. 9, and continue one month. This was a great success last year, and every effort will be made to have the exhibition excel, this year, in every department. Our Fair List will appear next month as usual, and we ask those Secretaries of State, County and other Societies, who have not sent us their official announcements, to do so as early as possible. It is a very difficult matter to make up an accurate list of fairs, as the papers published in the same county and town, often disagree as to dates. We ask the secretaries to help us make our list as correct as possible.

Ammonia in Peat.—"Lime" Passaic, N. J. The advice of your neighbors as to the best way to use swamp-muck is correct, and that of your city friend is incorrect. Peat contains nitrogen, but does not contain ammonia, either free or in combination with an acid, and it is only such ammonia that is drawn off by lime or potash. Peat-muck applied to a field as driven from the swamp, is of no immediate use, and we have had no visible benefit from a copious dressing of it. But if decomposed by lime, the nitrogen in the peat, which is inert of itself, is slowly changed into ammonia, which remains in the peat, in combination with acids, until absorbed by the soil or used up by the plants to which it is applied. Thus fresh blood, flesh, leather, and other animal substances are rich in nitrogen, but may be mixed with lime without any ammonia, or any smell being given off. But as soon as the nitrogen is changed into ammonia by decomposition, a strong smell is perceived on the admixture of lime or potash. Ammonia consists of one atom of nitrogen, with three of hydrogen, and this combination takes place during the decomposition of substances which contain nitrogen, and are therefore called nitrogenous substances. Peat decomposes slowly, and several months rest in the heap mixed in alternate layers of one load, with one bushel of lime, is necessary to render it fit for use. After that time it becomes fine and spreads easily. Peat thus treated contains ammonia in varying proportions of one per cent or less, up to three per cent.

The Cattle Business in New York.

—A change of great importance to feeders of cattle has gradually taken place in the method of conducting the trade in live stock in New York. The slaughtering business is now in the hands of a few men, and hardly more than a dozen of city retailers kill any beefs, sheep, or calves. The meat they sell is purchased at the large slaughter-houses, or the wholesale meat-market, by the

side, quarter or carcass. The few retail butchers who still purchase their live cattle are gradually changing their methods, and by and by doubtless they will fall into the regular channels of the business. The effect of this is to narrow the competition and prevent sudden fluctuations in prices. A few men can now make the market, and as it is to their interest to keep prices steady, it is to the interest of the country dealers and graziers that this state of things should continue. The prices quoted in the market reports now more nearly represent the actual value of the stock than at any former time, and shippers from the West may be more certain of realizing a fair market price than they could previously do. The concentration of business in a few hands cheapens the cost of handling the stock and the meat, and this saving in cost, of course, comes ultimately either to the producer, or the consumer, or partly to both of them. Fat cattle from the West are subjected, on their arrival here, to a shrinkage of 60 lbs. to the 1,000 lbs. of live weight. They are then sold on an estimate of 57 to 58 lbs. to the gross hundred weight. Beefes, which weigh 1,200 lbs. in Chicago, will thus weigh on their arrival here 1,128 lbs., and will be sold on an estimate of 640 lbs. nett weight.

As to Tile-Drains.—"Subscriber," Waterbury, Conn. The water enters the tiles in drains between the joints. In laying tiles, care should be taken to have the joints as close together as possible, and to cover them with compact soil. The largest portion of the water enters from beneath tiles and at the sides, scarcely any entering from immediately above them. As the flow is a gentle percolation through the joints, there is only a trifling amount of sediment carried in, and to get rid of this, "silt basins" are made in the drains. "Waring's Draining for Profit" explains all this very fully, and should be studied before any thing is done in the way of draining.

"Horse Books."—"M. E.," Walla Walla, W. T. The best book upon horses for general use is probably Stonehenge's "Horse in the Stable and in the Field." Its cost is \$3.50. It may be procured at the office of the Orange Judd Company, 245 Broadway, New York. If a mare does not become in foal after repeated visits to the horse, it is common to bleed her, and reduce her condition by physic and exercise. A run at pasture along with a horse for a few weeks, will frequently lead to the desired result. In such a case the shoes should be removed, to avoid injury.

The Potato-Rot.—"G. W. S.," Mifflin, O. The origin of the potato-rot is a somewhat disputed point, but we know in a great measure how it may be avoided. The crop should be grown only upon well drained, warm land, a light loam with some gravel in it, is the best soil; only well rotted barn-yard manure should be used, or some good superphosphate applied in the hill. Wet clay soils, fresh unfermented animal manures, and a wet season, are productive of rot, and if the first two are avoided, the crop often escapes the effect of the last.

What Part of the West?—"B. B. B.," Greene Co., Ohio. What part of the West is the best for farming or stock raising, depends upon many circumstances. If the emigrant has but little money and much patience and perseverance, he may choose the neighborhood of one of the great railroads, where homesteads are still vacant. Through the Arkansas Valley, along the Aitchison, Topeka, and Santa Fe railroad, the winters are somewhat shorter than in the Platte Valley, upon the Union Pacific and the Burlington and Missouri roads, and there are homesteads far out upon each of these roads. If he has more money, he would do better to purchase lands near towns from any of these roads, but before selecting his home, we would advise him to go and look for himself. The present month would be a favorable time to examine the Western country.

How Drains Act.—"Milo," Telmacana, Texas. The water which runs into drains dug in tough clay soil, enters from the sides and the bottom, and not from immediately above the drains. The toughest clay is sufficiently permeable to water to allow it to pass through readily, and after the drains have been in operation some time, regular and permanent water channels become established in the soil leading from above to the bottoms of the drains. In digging drains in tough, compact clay, numerous small veins of water are cut, which show very clearly how readily the water will pass through such soil as soon as outlets are provided. The advantage of the deeper drains is thus explained, and it is readily seen that their influence extends further in proportion to their depth.

See Page 313—Basket Page 313.

"Walks and Talks" Correspondence.

So many persons write to the author of "Walks and Talks," asking questions upon the topics therein treated, that to answer them in the articles would either extend them unduly, or crowd out other matter. To obviate these difficulties, we give Mr. Harris a place in the Basket columns, where his answers to correspondents will hereafter be found under the above heading.—Ed.

Pigs and Acorns.—"C. P.," of N. Y. city, writes: "I bought a farm of 320 acres in Virginia. Shall move on to it this fall. I am going into the milk dairy business, and want to raise pigs. Being near a city where I find a ready sale for fresh milk at 30c. per gallon wholesale, there will be little chance for skimmed milk, or butter-milk. The buildings are surrounded by a grove of 7 acres of large oak, with a few hickory trees. Adjoining this grove is a wood-lot of 27 acres, mostly oaks. Both are fenced in. Many bushels of acorns cover the ground in the fall and winter. But I want to save all the manure from the pigs for my fields, and what I want you to tell me is how to utilize the acorns and save the manure."

There is no way of saving all the manure, except by gathering the acorns, and this, of course, will not pay. The best plan I can think of would be to keep the pigs out of the grove and wood-lot until the acorns had commenced to fall freely, and there was a full feed for the herd on the ground. Then turn in the pigs for an hour at a time twice a day, and keep them in the yard or pens at night. After they have got a good meal of acorns, the pigs may be brought back to the yard, or turned into a field of stubble or grass that you wish to enrich by their droppings. By doing this regularly at a given time, and by giving them a few ears of corn in the yard or field, the pigs could soon be taught to come when they are called. If you can get 30c. per gallon for milk at wholesale, sell every quart of it. At such figures you can afford to buy guano and artificial manures to raise grass, corn-fodder, and mangles, to feed your cows. Do not go too largely into the pig business, until you have had more experience.

Hurdles for Pigs.—"C. P.," further says: "Having no fences in the fields, I intend hurdling my pigs on clover lots." All of us, at some period of our lives, intend to do a great many things that we never accomplish. I think in C. P.'s case hurdling pigs on clover will be one of them.

Value of Acorns.—"What is the comparative value of acorns as food for pigs?" asks "C. P." According to the tables given by Prof. S. W. Johnson in "How Crops Grow," 100 lbs. of corn contain five times as much nitrogen, and about twice as much available carbonaceous matter, as 100 lbs. of acorns. I should think 100 lbs. of corn worth at least as much as 300 lbs. of fresh acorns. The manure from pigs feeding on acorns would be worth comparatively little.

Varieties of Wheat.—"R. P. E.," Cumberland Co., N. J., asks if I think the Diehl wheat will do well in that section. I can not tell. Like all good varieties of white wheat, it requires better soil and better treatment than the hardier and coarser varieties of red wheat, such as the Mediterranean. Mr. E. says they have not raised any white wheat for a considerable time, but can grow 25 to 30 bushels per acre of red wheat. Soil, a sandy loam, with a red clay subsoil. The Fultz wheat, he says, is being tried to some extent, and promises well.

All I can say is that the Diehl wheat is the best variety of white wheat I have yet tried. The millers do not like it as well—or at least they say they don't—as the Boughton or Sonles. The latter has almost entirely disappeared in this section, and the Boughton was never raised here to any considerable extent, as it proved too tender for our winters. Last year the Diehl was badly winter-killed, and many of our farmers gave it up and went back to the Mediterranean. This year the Diehl gives a good crop on good land. It should be sown on no other. If land will not produce a good crop of red wheat, it is useless to sow the white varieties. But if your land will produce a large crop of Mediterranean—so large that it is frequently lodged—try the Diehl. If it does well, you will get a larger yield of grain, and it will command a better price. It has remarkably stiff straw, and yields much more grain in proportion to straw than any variety I am acquainted with. Some of our farmers object to it on the ground that the straw of the Diehl is so hard and stiff, that it is not as valuable for fodder as the softer straw of the Mediterranean wheat.

Rape for Sheep.—"R. P. E." also writes: "My experiment with rape for winter pasture for sheep I consider eminently successful. I sowed early in August, after early potatoes, and by November had a heavy, dense growth, almost equal to a heavy crop of clover. Winter was open, with little snow, and the sheep fed on it all winter, and with great profit in the saving of hay and condition of sheep. I sold the sheep and lambs at the same time for \$12 the pair, in April and May. I sowed some rape seed in my corn field. It did not do near so

well as the other, but well enough to warrant me in recommending the plan to those who have no other and more suitable ground. My land is in fair condition, having raised 600 bushels of ears of corn on the five acres where the rape was sown."—Several of my correspondents, who have tried rape and mustard, have not found the advantage they expected. They are comparatively new crops in this country, and we need more extended trials, before recommending for general introduction. Mr. J. S. E., of Darlington, Pa., writes me, that he sowed rape two years ago, and that "the frosts of November froze it to the ground, and he got no use from the crop."—If he had turned the sheep on to it, I am inclined to think he would have found that it was less injured by the frost than he supposed from its appearance.

Swindling by Mail.

MORE BIG CREEK BAGLEYISM.

Our attention has been called to the article in the *Agriculturist* for July, entitled "Swindling by Mail," as being specially interesting to seedsmen in general, and soft-hearted ones in particular; we perused it, as it seemed to carry the conviction that we too had been victimized. Examining our books we find that in April last year, the Big Creek fraud had free seeds for the season. Upon further investigation we find that last February we were favored with four pages of poverty from the pen of a female Bagley, a Mrs. M. C. Bagley, of Big Creek. A letter containing an order for seeds amounting to \$10.95, and enclosing cash for same had been lost, so the story opens. We took the course usually taken by other seedsmen, offering to fill the order upon receipt of half the amount said to be lost. This offer was followed by many thanks, and an enquiry on departed finances, with the proposition that it would be more satisfactory to share the loss by sending half the seeds without further remittance. We failed to appreciate that logic, but filled the order out of charity, little suspecting that such a combination of "soft sawder" and rural simplicity, was but a veneer for rustic rascality. We are of opinion that Bagleyism blooms luxuriantly in Western, as well as Southern sections of the country, for there are other names familiar to us of persons who periodically suffer the loss of money which was never sent.

WASHBURN & Co., Boston, Mass.

Something about Patents and our Patent Department.

More than one correspondent has written to express his surprise that we should frequently find fault with the Patent Laws, and at the same time have a department for the securing of patents, and a brief explanation will satisfy a number of readers. In the first place we unmercifully pitch into those who, under pretence of having a patent upon some article long in use, attempt to swindle farmers and others out of their money. These are treated just as any other humbugs. Our patent laws are on the whole for the general good, and for the most part they are wisely administered. Still, the laws have defects, and patent examiners being human, make mistakes. We shall continue to expose the laws where they seem to us to be wrong—and in this we know we have the sympathy of the officers of the Department, and if the office grants patents in cases in which we think they should be refused, we shall express our opinion, now that we have a patent department connected with our office, just as freely as we did when we had none. Hundreds of our readers have written that they had made some invention, and asked us how they could get it patented, and wished to know if we could recommend them to an agent of whose fair dealing they could feel assured. Some months ago it came in our way to make an arrangement with a gentleman, who not only stands well with his clients, but is on a most excellent footing with the officers of the Department at Washington, to undertake the many cases which came to us. We were very glad to be able to say to our friends that their applications could be attended to in our own office, and that they could rely upon being faithfully served, not only as to the character of the advice given, but at the most moderate charges for such service. That this arrangement has met a want on the part of the public is testified by numerous letters; long-time friends of the *Agriculturist* express their great satisfaction at the establishment of a patent department, and show their sincerity by giving it their business. The following extract from a letter, dated Kent Co., Md., will serve as an example of numerous others: "Your department I think highly useful and important, to the inventor, not only in assisting him in procuring patents, but in guarding him against patenting things of no value."—Another writes from Fairfield, Iowa: "Thanking you for the fidelity and promptness with which you have transacted my business,

I remain, etc."—A reputation for "fidelity and promptness" is what we shall endeavor to maintain, and we hope that our readers will make this department known to such of their mechanical friends as do not take the paper. While we shall do our best to give all who apply to us the benefit of the laws as they now exist, this will not prevent us from suggesting improvements in these laws, and in this as in other matters our editorial department will treat these topics as it considers best for the public good.

The Potato-Bug in the West.

The following is from a correspondent in Illinois: Eastern farmers, who have had this season their first experience with the Colorado potato-bug, may be interested in a few notes on the actual warfare against the bugs, as it has been carried on among those who are now veterans in the fight. In many localities the bugs gain a foothold the first year of their appearance, because there are comparatively few of them. Insignificant numbers do not provoke general offensive movements, and the bugs, increasing during the summer, begin work the second year in overwhelming numbers. When the bugs first appeared in Ohio, people held many theories in regard to their poisonous qualities, and in regard to the best methods to destroy them. There was a mystery about these potato enemies, and people disliked to come down to close quarters. The papers described how certain individuals had been poisoned by bite or sting, and timid people found in this an excuse for letting the bugs alone. Some one announced through the papers that his ducks ate the bugs, and another man that his turkeys ate them. Every one who had ducks and turkeys waited for them to do their duty as bug-destroyers, which they rarely did. Many tried to frighten or stun the bugs by firing shot-guns in such a way as to rattle the rows. This plan was popular with the boys. It was discovered that the soldier-bug, lady-bug, etc., warred upon the potato-bug, and forthwith boys and men suspended labor, as if to give the gallant soldier-bugs a fair chance. Paris green, mixed with flour and plaster, was used. But then this was poisonous, and the dust from it entered the nose and eyes. This objection was met by mixing Paris green with water—a large table-spoonful to ten quarts of water—and this sprinkled freely over the vines. But many who mixed the Paris green and water, neglected the important feature of stirring, and failed to accomplish what they expected. And then the application of this killed soldier-bugs and lady-bugs, as well as potato-bugs. This was an objection. Many men, who understood what the soldier-bug was doing against the common enemy, refused to use Paris green. These men picked the potato-bugs off by hand, and burned them, or brushed them off, and plowed them under, or brushed them off at noon-day, and saw them roast on the hot, sandy soil. Others invented wooden tongs, with a movement like the old-fashioned sheep-shears, and killed the bugs with these. In many localities the tongs were popular; in other localities people laughed at them. In one neighborhood it was firmly believed that mustard, growing among potatoes, was a defence against the bug, while in a neighboring township this was pronounced a humbug. People held tenaciously to certain methods. A, B, and C would work hard, and clear their grounds of the pest. D would let them go, and from his grounds A, B, and C received new instalments. This would never do. The farmers in the township organized, and all cleared their fields of the potato-bugs, and then they had potatoes. In this way only was effective work accomplished. Farmers must work together, and work in earnest. Where there were farmers' clubs, this kind of work was easily inaugurated, and carried to a successful issue.

The result of experience is: When there are comparatively few bugs, pick them off as soon as they appear, and destroy them. If the eggs have been deposited, destroy these. When the bugs are numerous, use Paris green with water. This is safer, and more economical, than when used dry with flour or plaster. When the bugs appear the first season, do not flatter yourself that you are to be more fortunate than your Western neighbors, because they are few. The advance guard once in position, you are at a disadvantage. Destroy the advance guard, and he ready the next season to continue the work of destruction.

Bee Notes for August.

BY M. QUINBY.

Bees in Kentucky.—O. Brumfield, Boyle Co., Ky., writes: "How can I best shade my bees in the absence of shade-trees? I am living at a newly built place, and have not a tree, except small ones just planted. How would a long arbor covered with grape or hop vines do? I have about 50 stands. How close should they be

placed? When bees are in a cool place, and will persist in hanging outside the hive instead of in boxes, what had better be done with them? Last year I had about eighty hives; lost thirty in winter. I suppose five-sixths of the bees in this section (Central Ky.) died. Mine died mostly in spring."—Bees protected from cold north wind and exposed to the sun during the early part of the season, are better off than if shaded. Many stocks were lost, even in the Southern States, last April, apparently on account of chilly winds and cool weather. If it could be arranged that they receive the sun's rays until some time in June, and then be shaded, it would be nearly right. Probably hop vines would do it best. A movable roof of some sort should protect each hive from the rain; if its dimensions are ample, and it is raised just a little above the hive, it will do very well in the absence of a leafy shade. It can be removed in fair days during spring. The distance apart for stands should be six feet, and as much more as space will allow, if it is fifty feet. If there is room enough in the hive, or boxes, bees will not hang outside the shaded hive idle, except perhaps occasionally an hour or two towards night.

Kinds of Honey.—In New York State, different localities, only a few miles apart, produce distinct qualities of honey. In different States and latitudes the quality of honey varies. Nearly all sections yield some from fruit blossoms and dandelions. It is not often that we obtain much surplus honey until clover yields it, and this is considered superior to most kinds. When bees can reach bass-wood, larger quantities are obtained in less time than from clover. The distance they will go for it, greatly depends on the serenity of the weather. The appearance of bass-wood honey is equal, if not superior to that from clover. It has an aroma greatly prized by many. It yields from July 1st to 20th usually in this locality. Buckwheat, in some sections, supplies the greatest yield. It is dark colored, and the flavor not so pleasant to most palates. When it is desired to keep the white honey separate, all the surplus should be removed now. In sections where buckwheat is grown plentifully, bees will often obtain enough, and often much more than is sufficient for their winter stores. In some places, as the prairies of the Western States, the asters, golden rods, and other late flowers furnish honey of medium quality; the bees will winter on this. If honey that is stored in boxes, or even that in the body of the hive, is taken with the extractor the beginning of this month, the bees will usually accumulate enough for winter. If they fail to do it,—which may be known by weighing—feed syrup of sugar, which is just as good as honey, until their stores are ample.

Cleaning Stubble Land.

The farmer who has a field which has grown wheat, or barley, or oats this year, and is not seeded down, and which is not to be sown with any other crop until next spring, has an opportunity of cleaning his land, that should on no account be neglected. The English farmers seldom seed down their land with wheat. After the wheat is harvested, they harrow the land, or tear it to pieces with a three or four-horse cultivator or "grubber." This pulls out the roots of quack-grass, and starts the seeds of other weeds. The field is afterward plowed, when, of course, all the young weed-plants are destroyed. The grubber is kept at work as often as necessary to clean and mellow the land. The next spring this land is sown to turnips or mangels, or, on heavy land, to beans or barley. It is said that this autumn cleaning of stubble land by the free use of the grubber, especially when operated by the all-powerful steam engine, is one of the greatest agricultural improvements of the age.

What is true of English farming, might be still more emphatically true of American agriculture. Our autumns are longer, and drier, and hotter than they are in England, and we have a better opportunity to clean our land, while there is certainly a greater necessity. Our fields are fearfully foul with all kinds of weeds, and in many instances they are annually gaining a stronger foothold. We must fight, if we would win. It will not do to go on in the old way. With our drying winds and hot sun we ought to have the cleanest farms in the world

—and sooner or later such will be the case. We must kill weeds by wholesale. It will not do to depend on the hoe and the fingers. Nature is never at rest. It will not do to let land lie idle. When it is not occupied with growing crops, we should be occupied in stirring the soil and killing weeds. It is the great secret of success in farming.

The Osprey, or Fish-Hawk.

Upon the first page is given an engraving of the American Fish-hawk, or Osprey (*Pandion Carolinensis*), and its nest. This bird is found in all the temperate parts of the United States, and is well known to those who live near the sea, or large bodies of water, for its skill and industry in fishing. Its length is about 25 inches, its wing 21 inches; the head and underparts are white; the top of the head, upper parts of body, wings, and tail, of a deep brown, and there is also a stripe of the same color through the eye. This bird arrives in the Northern States late in April, or early in May, and builds its nests in the vicinity of the sea, a lake, or large river, a number of pairs often locating within a short distance of one another. The nest is usually in the top of a large tree, and frequently a decayed one is selected; it is about four feet across, usually as high as broad, is composed of sticks and coarse grasses, and lined with sea-weeds and the finer grasses; the same nest, with annual repairs, lasts the same couple for several years. Three eggs are laid, and when the young are hatched, the parent birds are assiduous in supplying them with fish. The Osprey sails in mid-air until it spies a fish, and then, by a sudden dart downward, seizes it in its talons, often in its plunge going quite beneath the water, and as it rises, seldom fails to bring its prey, which it carries to its nest, provided it is not robbed by some Bald Eagle, which has been watching the movements of the more industrious bird. For a bird of prey, the Osprey is remarkably peaceable, living not only on good terms with its own species, but with other birds. Indeed, it allows various smaller birds to build among the outer sticks of its own nest, a peculiarity which the artist has recognized in the engraving.

How to Kill Wild Mustard.

A correspondent of the *American Agriculturist* has a farm well stocked with Wild Mustard, or Charlock, and he wants to know how to get rid of it. His rotation is corn on sod, barley, followed by winter wheat, and seeded with timothy in the fall, and clover in the spring. His barley crop is badly infested with wild mustard. He has pulled it out of the barley, but it is a good deal of work, and he thinks his labor is thrown away, as there are more "yellow-heads" now than formerly.

We would suggest the following plan. Plant corn as now. Cultivate thoroughly, and as late in the season as possible—say up to the first week in August. As soon as the corn is cut, and while the stooks are still in the field, cultivate between the stooks with a two or three-horse cultivator. After the corn is husked, and the stalks drawn in, cultivate the field again, and afterward plow it, and leave it for the winter. The next spring cultivate it as soon as the land is in good condition to work, and harrow, and roll. In a week or ten days, plow, cultivate, harrow, and roll, till the land

is as fine and mellow as a garden. Then instead of sowing barley, plant it again to corn, or potatoes, or root crops, or beans. The latter are perhaps best, as they need not be sown till the middle of June, and wheat may be sown after them in the fall, and thus you can seed down the land, at the same time as you would, had you sown barley.

The thorough cultivation, and the repeated plowings, will make the land so fine and mellow, that the mustard seed will start freely in the spring. If you plant corn, or potatoes, or roots, the mustard will be killed by the cultivator or hoc. If you plant beans, there will be time to give an extra plowing in June, and this will kill all the mustard plants, and if more plants spring up afterwards, they will be killed when you are cultivating and hocking the beans.

If you plant early potatoes instead of barley, they may be dug in time to allow of sowing winter wheat. But if you plant corn, or sow root crops, and wish to follow them with barley the next spring, we would drill in the barley early in the spring, put in two or two and a half bushels of seed per acre, and put it in deep, and roll immediately after the drill. Then when the barley is fairly out of the ground, and when the young mustard plants are just starting, go over the field with a fine-tooth harrow; lap enough to completely scratch over all the surface of the soil, and thus tear up and kill the young and delicate mustard seedlings. Do this work thoroughly at once, and then follow immediately with a roller. This will kill thousands of weeds, and will not injure the barley. If you wish to seed down the land, sow the clover and grass seed, after the harrowing and before the rolling. There is no better crop to seed with than barley.

Ogden Farm Papers.—No. 54.

What a country it is; and what a people! I have a letter from a farmer in this State, asking my advice concerning the recommendation of an "Agricultural Chemist," who comes to him with the endorsement of certain wealthy men of Providence. This chemist has found a short cut to agricultural wealth. "He can analyze the soil by putting it in his mouth, so that he can tell exactly what that soil wants to make it perfectly productive, and to continue to improve without manure, except some chemical preparation of ammonia or alkali, which he will give directions for making from soda-ash and other things, the application of which, at an expense of one, two, or three dollars an acre, will set in motion the latent powers of the soil, and produce fine crops, year after year, without other manure. He goes through each field, and tells what to apply to each one, and how to make it. His charge, he says, is quite moderate: says he was brought up a soap manufacturer, etc., etc. Now, we are all anxious to make some money at farming, and setting aside the heavy expense of manure, we can do it. My farm has been heavily manured for years with fish, and he says I am walking over thousands of dollars every day that are latent in my soil, and that he can set in motion at such a trifling expense, and so little trouble. Is he a humbug? The loss of one crop through him would be to me a serious matter; therefore I ask your advice."

Of course he is a humbug. He has gone from the substantial industry of making soap to the more promising one of making "soft-soap," with which he will smear light-headed farmers,

until he makes them believe that they can get something out of nothing, and I have no doubt, as the fools are said to be not all dead yet, that he will make a good thing of it. The temptation to travel on a royal road, and to win success by a short cut, is strong with us all, and a glib-tongued traveling-agent generally finds us good plucking. Certainly there is much latent fertility in the soil, and there is no doubt that it may be more rationally developed by the use of ammonia and other stimulants, but unless this is done with judgement, and unless the product is so used, as to return manure to the soil, all excessive production will result in greater ultimate impoverishment. It will be the wisest plan to develop the "latent fertility" by growing good crops of clover, and by other judicious processes of good farming, and to stick closely to an intelligent application of "the good old way." It is pretty well determined, that the best laboratory analysis of the soil is of very little value as a guide in manuring, and we should hesitate to advise our readers to put more confidence in an analysis made by "putting the soil in the mouth!"

A correspondent in Wisconsin asks: "Would it do to cross a Jersey bull on a grade Ayrshire heifer? My Jersey bull is getting very fine calves from native cows. The first one of these calves that has bred, is a fine milker, with very rich milk. She calved at 17½ months, and is now giving about 12 quarts (calf three weeks old). The bull is fawn and white in color, darker about the head, fine horns, and the yellowest skin I ever saw. He is 3½ years old, and weighs about 1000 lbs.; is very quiet and orderly. Out of about 100 cows that he has had, there have been but 15 or 20 bulls. His calves from deep red or brindled cows, are of a light liver color, with the white ring around the muzzle, and the deer-like limbs of the Jersey. By the way, I notice that the milk of my native cows, which have been served by this bull two or three times, is richer in butter than ever before—so that some of the qualities of the sire must impregnate the dam."—There is no reason why a Jersey bull should not be bred to a grade Ayrshire. The better the cow, the better the calf, and there is no better cow to be found for ordinary family use, than a cross between the Jersey and the Ayrshire (pure), therefore, the Ayrshire blood in the cow in question can be only an advantage. How much the bull has to do with determining the sex of the calf, is not known. It is perhaps a question of his relative vigor, as compared with that of the cow, some breeders claiming that if the bull is the more vigorous, the calf will be a female, and vice versa. The fact that the bull is a Jersey, can have nothing to do with the question; the fact that he is a choice animal, and is kept in unusually good condition, may have very much to do with it. The increasing richness of the milk of the native cows, which have been served by this bull, would be sufficiently accounted for by the fact of their increasing age. It is hardly necessary to go so far as to ascribe it to the effect of their having been served by a bull of a richer milk, which would be very far indeed.

Dr. McClure, veterinary surgeon, of Philadelphia, writes to say, that the tonic-recipe, communicated to me by Mr. Sam. J. Sharpless, and given in the May number of this series, was given by him to Mr. S., and that it is published in his work on the "Stable, Field,

and Farm-Yard." He claims that this tonic has been found quite as effective in staying abortion in the afflicted dairy-regions in New York State, as in the instances I cite. I cheerfully give him due credit.

I am always glad to have another herd than my own to use as an illustration of the value of Jersey blood in the butter dairies, and I have before me a statement of one year's product of the little herd of Mr. T. J. Hand, of Sing Sing, N. Y., who is now president of the American Jersey Cattle Club. The herd consisted of eight cows, viz.: one 7-yr. old, two 5-yr. olds, three 3-yr. olds, and two 2-yr. olds. There were two Ayrshires in the herd, one for four months, and one for three months. The time covered by experiment was one year. Four of the elder Jerseys were in the herd the whole year; one 5-year old only for the last three months of her milking period; one 3-year old for the last eight months; one 2-year old for the first four-and-a-half months; and another 2-year old for the first five months. Three of the older cows calved twice within the year. The milk of one cow was furnished to a neighbor for June, July, and August. Deducting these three months, the herd foots up 7 $\frac{1}{2}$ months, including the dry period of three cows. Deducting (as is usual) one-half of the time of the two 2-year olds, or 4 $\frac{1}{2}$ months, we have 68 months in all, which is equal to *five and two-thirds* cows for one year. The calves were fed with fresh milk until one month old. The milk and cream used in the family were estimated to equal a product of more than 350 lbs. of butter, but as this is only an estimate, though I do not doubt its correctness, I propose to reduce it to one-half the amount, and call it 175 lbs.

There were actually churned 1,617 lbs. of butter. Adding the 175 lbs. above, we have 1,792, which, divided by 5 $\frac{1}{2}$, gives over 316 lbs. per cow per year, besides the feeding of the calves. 1,404 lbs. of butter were sold for \$965. If what was consumed by the family had been sold for the same price (69c. average), the whole product would have brought \$1,206, or \$21. per cow. Sold at a low average price for butter shipped to the general market in New York, say 30c. net, the product would have been \$537.00, or \$95 per cow, which is fully \$45 per cow more than the average of good dairies in New York State, where "native" cows are kept. This \$45 represents the value which would directly accrue to a dairy farmer of the better class, if he used Jersey cows instead of native cows. Indirectly he would have the further advantage of a better quality of product, which would add at least 5c. per lb. to its value, and \$15 per cow to the net income.

Practically, any farmer, in order to realize the same result, would have to follow Mr. Hand's better method of feeding, or he would fall short of his large result, but the result is due quite as much to the breed as to the feed, and the whole example (except in the matter of price) is a perfectly easy one for any farmer to follow. Now, who can supply himself with Jersey cows. Of course the large majority of farmers can not do this, but \$100 will buy a first-rate Jersey bull calf, of the best butter strains, and one such in a dairy neighborhood will, in a few generations, give such an infusion of improved blood, as will add thousands of dollars to the permanent wealth of the community.

One of our experiences, which have been before referred to in these papers, it may be worth while to report upon again.—That is the

manner in which we are supplied with water. About 1,000 feet from the milk-house, and 800 feet from the barn, there is a well in which the water usually stands at a level 48 feet below the top of the tank in the barn, and about 35 feet below the point at which the pipe enters the milk-house. The communication for the whole distance is by means of a wooden pipe (4 inches square, with a 1 $\frac{1}{2}$ inch bore). Under the barn a branch rises to the tank, and by turning a stop-cock, the water is stopped from its flow to the dairy, rising to the tank. When this is filled, the cock is opened, and the water passes on to the dairy, where it always flows when the pump is at work, which is whenever the wind blows (fully three-quarters of the time), keeping the water always fresh and cool in the vat in which the milk-cans are immersed. Occasionally, in very dry weather, the well furnishes a scant supply, and we then have to use ice, but practically we are rarely without an abundant supply of water.

For some years we found the wooden pipe troublesome, as it will occasionally spring a leak. When this happened, it cost nearly ten dollars to insert a section of lead and iron pipe. We finally hit upon a plan, which removed this objection: As the leak in a wooden pipe is always a split, it is only necessary to squeeze the pipe firmly together, and this is cheaply and quickly done with an iron clamp put around the pipe and screwed tight. This removes the only practical objection to this tubing, and enables us to use, at a cheap rate, a conduit of large bore. This is a great advantage, for the resistance by friction is considerable in a small pipe. In a larger one, as a given amount of water is delivered by a slower current, the friction is less, in proportion to the squares of the diameters, being four times less in a two-inch pipe than in a one-inch pipe. Consequently, the saving of power in a large pipe is very considerable.

The motive power of the pump is a self-regulating windmill, and in the use of these we have had a varied experience. The first mill put up (six years ago) was an old-style Empire Mill. This worked very well for two years, then it became worn and shaky in many of its parts, and had frequently to be repaired during the following year, and was finally wrecked beyond the possibility of repair. This was followed by a new and improved style of the same make, but, from want of strength in some of its parts, this was partly wrecked in less than a year, and had to be repaired at considerable cost. Finally, in March last, it met with another accident, and had to be abandoned. Then I cast about for a mill of more simple construction, and concluded that the most perfect machine of the sort now offered is the United States Mill. As the former mills had obviously had more power than was worked, being 12 feet in diameter, I decided on a U. S. Mill 8 feet in diameter. This has now been running sufficiently long to prove its capacity to give us all the water we need, and more, and from my previous experience with self-regulating mills, and with machinery generally, I am satisfied that the chance for permanent usefulness is very good. This new mill cost only \$100 (the previous ones cost \$175 each), and we are fairly started on our seventh year, with an outlay of say \$500 for power. This is considerable, of course, but the benefit derived has been very great. Aside from having ample water for a large stock, winter and summer, we have fresh, cool water for the milk vat, without which we should be unable to

make the uniformly good quality of butter, on which much of our income depends.

We are having a capital season for grass, and thus far the frequent rains have been kind enough to come at a time when they did more good to what was standing, than injury to what was cut.

In detailing the operations of the farm, it seems proper to follow the commendable example of many other breeders of thoroughbred stock, and give an account of our sales of Jerseys. During the first half of the current year we have sold as follows—partly from the home herd, and partly from the branch in Southern Illinois (where, if we get only one-third of our Eastern price for butter, we pay less than one-third the Eastern price for hay and pasture). Bull calves sold (less than 1 year old):

M. D. Ralph, Rodman, N. Y., Belnor, No. 1,018.
Edgar Doolittle, Onaquaga, N. Y., Callidan, No. 1,039.
Andrew Thompson, Brushland, N. Y., Rhode Island, No. 1,333.
Andrew Thompson, Brushland, N. Y., Jesse Burnett, No. 1,370.
Chas. J. Reed, Fairfield, Iowa, Sapper, No. 1,026.
Jos. Y. Heckler, Harleysville, Pa., Julius, No. 1,383.

Yearling bulls:

Dr. J. C. Gunnell, Alexandria, Va., Merry Andrew, No. 719.

J. M. Brown, Portland, Me., Tug, No. 1,126.

Heifer calves:

Dr. N. R. Boutelle, Waterville, Me., Fantibel, No. 2,679.
Campbell Brown, Spring Hill, Tenn., Roxabel, No. 2,743.
" " " " " Renebel, No. 2,772.
" " " " " Donora, No. 2,680.
" " " " " Beleva, No. 2,677.
Chas. J. Reed, Fairfield, Iowa, Kyridonna, No. 2,681.
" " " " " Beloona, No. 2,676.
Geo. W. Palmer, Saltville, Va., Belvira, No. 2,771.

Yearling and 2-year olds:

Campbell Brown, Spring Hill, Tenn., Duchie, No. 2,500.
" " " " " Anna Roxbury, No. 1,803.
G. J. Shaw, Detroit, Me., Madagascar Queen, No. 1,806.
J. M. Cobb, Beloit, Wisconsin, Moonah, No. 2,688.

(The numbers refer to the entries in the Herd Register of the Am. Jersey Cattle Club.)

The 20 animals sold for \$2,740, being an average of \$137. 8 males sold for an average of \$83.12. and 12 females for an average of \$172.92.

Just as I am finishing this I have a second letter from my correspondent, whom I had advised to spend no money on the testing "chemist." He says: "A neighbor of mine paid him \$35 to go over his farm. If he had offered to go through any kind of regular analysis, I should have invested in him too, but the mouth analysis made me hesitate. He says he came down this way for sea air, that his system is full of 'pizen' from the dirt in his mouth so much. He said he could not only tell by the taste, but he could see the different constituents of the soil run different ways, separated in the saliva when he spit it out. His certificates were genuine, and from some of the best people in Providence. He has spent two days with a wealthy neighbor, and bagged \$50 or \$75 from him. What do you think will come next? A man was along to get subscribers for a book, to tell farmers how to make any quantity of manure at almost no cost at all—price \$10. He got about 50 subscribers in this town. When the book came, it advised saving the sweepings of the house, the soot from the chimneys, and all the dead things to be found round about."

The last fact stated, makes it seem worth while to recount this nonsense.

Animals for Exhibition and for Use.

It must be confessed that there is a wide gap between the breeders of our most highly valued stock, and the farmers, for whose interest, it is the fashion to say, that these costly animals are bred and exhibited. If a Shorthorn bull

or cow has any intrinsic value at all, it is only so far as it promises to affect the value of our general farm stock in the near or distant future, and in so far as at some time to come the milk pail may be filled, or the butcher's stall may be weighed down with its produce. Certainly no one supposes that a show-animal is valued for its product of milk, or the weight of beef in its carcass.

The ordinary farmer, viewing the mammoth proportions of a prize animal at one of our fairs, may possibly have some faint dream of a time when he may lead his cow to be served by such a bull at some cost within his slender means, but generally he views the animal in a state of bewilderment at the evident impossibility of that time ever coming.

Consequently there is a want of interest upon the part of the majority of visitors at State fairs, where our best stock is exhibited, while at less noted exhibitions, such as local or county fairs, this lack of interest is not so conspicuous. It has become a serious question, if the present eager disposition to run up the prices of Shorthorn stock to unprecedented figures, even at the risk of giving rise to suspicions of bolstering up prices by fictitious purchases, is not injurious to the general agricultural interest, and greatly retarding the day when we might hope to see the final fruition of the long continued labors of breeders.

Each sale and dispersion of herds only seems to remove farther than ever from the farmer of moderate means his hope of some benefit from this stock, and the possession of a "Duke" or a "Duchess" for himself. It has also become a question, if the high feeding resorted to, to get show animals into condition, is not injuring, if not destroying, the usefulness of these favored families of stock. These remarks are intended to be general, but they apply with the greatest force to a few families of Shorthorns, which are never seen in public, but in

that state of uselessness, known as show-condition. We desire to propound the question at this seasonable period, if it would not greatly extend the usefulness of the Shorthorn, as well as every other high-bred class of stock, to exhibit at least occasionally some choice breeding animals in working condition? If agricul-

St. Ruth was awarded the first prize as a breeding animal in 1873, as a two-year-old, and certainly gave promise of success the present year. But the bull King Richard II. took the honors from him this year, among twenty-nine competitors, one of which was the bull Breakspear, an animal of American birth, which was found

worthy to be taken across the Atlantic. At first sight the judgment might be considered at fault, but when these bulls are considered as animals designed, not for show, but for service as breeders, the judgment is a proper one. A comparison of the merits of the two animals decides this point. Although both portraits are somewhat distorted in the process of photographing, one can sufficiently appreciate the finer head and fore-quarters of King Richard II., and his capacity for laying on flesh, to admit

his superiority, notwithstanding that he is thin and out of condition, and is light in the hind-quarters. The better condition of the St. Ruth bull would give him a great advantage, but not enough to overpower the greater possibilities of his rival. It is just the education to be given by the exhibition of such animals as these, and the opportunity for study furnished thereby, that are needed to remove the prejudice against what is known as fancy stock, on the part of a majority of our farmers, who visit the state and county agricultural fairs.

It is a fact that occasions mournful comment upon the part of Shorthorn breeders and live stock journals, that there is no demand for bulls, wherewith to improve the common stock of the country, and that only "fancy" bulls are in demand, and that by fancy breeders; also that "good, useful bulls are now selling at lower prices, comparatively, than they were twenty-five or thirty years ago." How much of this is due to the present system of exhibiting cattle at fairs, and to the absurd and impossible engravings, called portraits of

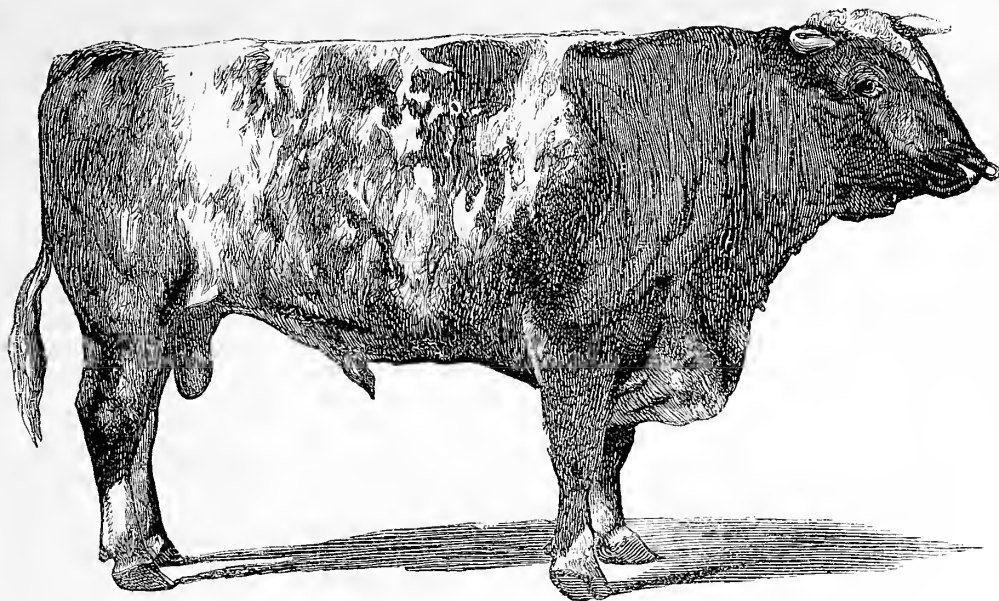

IRISH BULL "KING RICHARD II."

tural associations are what they ought to be—educational institutions for the benefit of the agricultural class—it would seem proper that such lessons should be given as could be understood and appreciated, and from which something should be learned by the largest class of visitors, the farmers. How little is learned by the great mass of farmers from the show-ring or stalls, filled with high-fed show-animals, we know very well from mixing with the crowd upon many such occasions.

We think they manage these matters better elsewhere, and notably so in Ireland, if we may



IRISH BULL "ST. RUTH."

judge from the report of the exhibition of breeding stock of Shorthorns, recently held at Dublin. As an example of how they do these things there, we have carefully engraved the two accompanying portraits of prize animals at the Dublin shows of 1873 and 1874, which appeared recently in the Agricultural Gazette. The bull

Shorthorn stock, so widely published by agricultural journals, for the wonderment of their readers, is a question which is inviting the attention of breeders. It is now fully time that the long talked of improvement of our common stock should begin, and this can not be done with \$14,000 bulls, nor \$40,000 cows.

Walks and Talks on the Farm.—No. 128.

Last fall, a week or ten days after the wheat was up, I went over the field with a Thomas' smoothing harrow. I did this for the purpose of killing the weeds, more especially red-root. This weed is a great pest. The seed germinates in September and October. The young plants make their appearance in the wheat in October and November, looking as innocent and harmless as red clover. During the winter they send out their tap-roots, and take firm hold of the soil. After this there is no way of killing them, except by hoeing and pulling. In the spring, especially where the wheat is thin on the ground, the red-root plants grow rapidly, and throw out numerous branches, each of which produce a bunch of flowers, and in a few days, or say by the middle of June, the seed is formed, and before clover is fit to cut for hay, the seed is mature enough to grow. It has a hard husk, and contains a good deal of oil. It will lie in the soil for years without rotting, and will start into growth in the autumn, whenever the condition of the soil is favorable. The rotation of crops, adopted in this section, is admirably adapted for the spread of red-root. For instance, we sow clover with our wheat. The next year we mow the clover for hay, and afterward for seed. The next year the field is either mown again, or pastured. The next spring it is plowed up for corn, cultivated until July, and the next spring it is plowed, and sown to barley, and after the barley is harvested, the land is plowed, harrowed, cultivated, and plowed again, and made very fine and mellow, and is then sown to wheat in September, and is sowed down with clover and timothy in the spring.

Now let us see what the result will be, so far as the spread of red-root is concerned. There is red-root in the wheat. It goes to seed, and a considerable proportion of the seed falls on the ground. In September such of the red-root seeds as find a good seed-bed, start up in the clover. The plants grow during the fall and winter months, and especially if the crop is light, the red-root plants flower and produce seed, and when the clover is made into hay, the red-root, with its seeds, is carefully stowed away in the barn or stack, and during the winter is fed out to stock, and the seeds find their way to the manure. This manure is drawn out, spread on the land, and plowed under, seeds and all, for corn. The seeds lie dormant under the furrow. The next spring the corn stubble is plowed for barley, and the red-root seeds are mixed with the soil. After the barley is off, the land is plowed once or twice, and well harrowed, and cultivated, and rolled, and then sown to wheat. And then up comes your red-root. It goes to seed in the wheat, and afterward in the clover, and in a few years our wheat farms are overrun with this pest.

Now, if we could discover some cheap method of killing the young red-root plants in the wheat, it would be a great boon. I had found, by repeated trials, that harrowing in the spring will not kill the red-root plants. They have then got too firm a hold on the soil, and so I thought I would try it in the fall. Three years ago I harrowed part of a field in November. The wheat, I thought, was better when it was harrowed, but it did not kill the red-root. I did not harrow early enough. Last fall I commenced to harrow the wheat as soon as it was fairly up, going the first time lengthwise of the drills. It did not pull up the wheat,

but where the soil was very mellow, it covered some of the plants. I found, that by going over the field with a roller before harrowing, this difficulty was to a considerable extent overcome. And if any are disposed to try harrowing their wheat this fall, I would strongly advise them to roll it first. I have always been opposed to rolling wheat in the fall. But in this case it certainly was a benefit.

I found that the first harrowing killed thousands of young red-root plants and other weeds, and I was willing to kill a little wheat for the sake of killing a good deal of red-root. But I soon found a new crop of red-root springing up from more seed. And so we harrowed the wheat again, going crosswise of the drills, in hopes that the harrow would uncover the wheat plants buried by the previous harrowing. It had this effect to some extent, and it also killed the young red-root plants. After this, say the last of October, we harrowed it again for the last time.

We certainly killed millions of red-root plants on this field of 13 acres, but, I am sorry to say, there were thousands left.

"Well," says the Deacon, "you ought not to grumble. You would have had a tough job hand-picking on that field, if you had not harrowed it. But we all think that you hurt your wheat by harrowing it."

"Of course you do," I replied, "you said the same thing when I first harrowed my wheat in the spring. Now, all the young farmers, and some of the old fogies, are in favor of spring-harrowing. I shall harrow my wheat again this fall, taking care, however, to roll it thoroughly, to press down the little ridges left by the drill-tubes, and leave a smooth surface for the harrow. I think, too, I shall sow my wheat earlier. I have usually sown about the 15th of September. If the land is in good condition, this is probably the best time. But on poorer land a week or ten days earlier may lessen the chances of a failure."

Several gentlemen have written me in regard to the sheep and lambs, which the Deacon and I weighed, asking me to weigh them again and report. If we were not so busy hoeing mangels, I would do so. The Cotswold rams are out in the lot back of the Deacon's, and we have not had them up to the barn for some time. But at the next opportunity I shall weigh them. As I said before, I do not go in for heavy weights. My rams are in rather a poor pasture, and do not have any grain. I believe in feeding them all they can eat and digest, when young, but after they are ten or twelve months old, they should be fed only enough to keep them in vigorous health. This stuffing thorough-bred rams with grain, and loading them with fat, for the purpose of showing at the fairs, is almost certain to result in weak, puny lambs. I think it is time that we stopped importing sheep and swine. At any rate, we ought to know enough by this time, not to import the "prize animals."

But I was going to say, that this morning (June 17) we had the flock of ewes and lambs at the barn, and put a few of the lambs on the scales. The following are the weights of some pure-bred Cotswolds. Ram lamb, born March 16, weight at birth, 14 lbs., April 18, 33 lbs., May 22, 60 lbs., June 17, 76 lbs. This is not bad for a three months old lamb. He would dress, according to my rule, 43 lbs. This is the largest, but not the best pure-bred lamb in the flock. A pair of twins, a ewe and a ram, born March 23, weighed at birth, ewe 9½, ram 10 lbs.

April 24, ewe 20, ram 24 lbs. June 17, ewe 45 lbs., ram 52 lbs. It will be seen that the single lamb gained 19 lbs. the first month, and the pair of twins 24½ lbs. During the three months the single lamb has gained 62 lbs., and the pair of twins, together, have gained 77½ lbs. A ram lamb, born April 18, weighed 12 lbs. at birth, and 53 lbs. June 17. Another, born April 30, weighed 14 lbs. at birth, and June 17, 60 lbs. This is a gain of 46 lbs. in 48 days.

The following are the weights of some *grade* Cotswold lambs. One ewe lamb, born March 14, weighed at birth 10½ lbs., April 14, 29 lbs., June 17, 71 lbs. Mr. Lawes' "fat lamb," killed for analysis, August 16, when about six months old, weighed alive 84½ lbs., and dressed 50½ lbs. This was a well-bred Hampshire Down lamb. I think my little *grade* ewe lamb, with only two crosses of Cotswold blood in her, and descended from a common Merino ewe, that cost me \$2.40, need not be ashamed of this comparison. If I do not forget it, I will kill one of these *grade* lambs, when of the same age as Mr. Lawes' lamb, and weigh all the different parts of the animal, as he did. I think I can beat him. I never liked Cotswold mutton, and I am not going to change my opinion on this point, simply because I happen to keep a flock of pure-bred Cotswolds. They are too fat for my eating. I killed one last winter with four or five inches of pure fat on the ribs. It is capital food to steam up, with a barrel of sliced mangels and corn-meal, for pigs that you want to push ahead rapidly. If a butcher wants a fat sheep that will dress 200 lbs, to hang up in his shop for show, let him have it. Don't kill it for your own use. When you want good mutton, get a well-bred *grade* Cotswold-Merino, and call it South Down.

In saying Cotswold-Merino, I do not wish to be understood as implying that Leicester-Merino, or Shropshire Down-Merino, or Lincoln-Merino, or South Down-Merino is not just as good. All I am contending for is that, with thirty million of sheep in the United States, and with flocks of pure-bred Cotswolds, Leicesters, Lincolns, Oxford, Hampshire, Shropshire, and Sussex Downs, where good rams can be had at low figures, there is no reason, why we should not have all the good lamb, and mutton, and wool, that the country needs—and that without importing another sheep from England. But all this time Fred is waiting to weigh another *grade* ewe lamb, born March 16, weight at birth, 12 lbs., April 14, 30½ lbs., June 17, 70 lbs. A ram lamb, born March 25, weighed at birth 11½ lbs., April 24, 31 lbs, and June 17, 66 lbs. A pair of twin-lambs, born March 22, weighed at birth, ram, 10½, April 18, 27 lbs., June 17, 65 lbs.; ewe lamb, 9½ lbs. at birth, April 18, 24 lbs., June 17, 51 lbs. They are not three months old, and the pair already weigh more than their mother.

After weighing the lambs, starting the men to cultivate and hoe mangels, corn, and potatoes, and Walking and Talking a little on the Farm, as above, I went to Rochester in the afternoon, got on the express-train at 5.25 P. M., and the next morning at 7 o'clock I was in New York. At 8.15 A.M. the steamer "Virginia Seymour," which had been engaged for the trip, left the pier at 33rd-st., East River, with a company of ladies and gentlemen on a visit to Beacon Stock Farm, on Long Island. Mr. Delamater, the owner of the farm, was on board, and gave us all a hearty welcome. We steamed up the river some forty or fifty miles, and reached the farm about noon. All this

time I was congratulating myself that I had left so quietly, that the men, who were hoeing mangels in the field at home, would be expecting to see my old hat coming round the corner, while I was between four and five hundred miles away, inhaling the invigorating air of the Atlantic ocean, and having a good time generally. Great is the age of steam! The readers of the *American Agriculturist* have frequently heard of Mr. Crozier's farming. Mr. Delamater owns the farm, and his long purse has furnished the required capital without limit. The land is naturally poor, but it proves amenable to good cultivation and manure. Mr. Delamater was fortunate in securing such an energetic and skillful Scotch farmer, as William Crozier, to undertake the labor of renovating this charmingly situated farm. He told him to do just what he pleased, to "go ahead and not bother me"—except with the bills! Mr. Crozier has gone ahead. Delamater and Crozier are such a team as we seldom see in this country. They pull well together, and are as strong as their favorite Clydesdales. I wish there were more such men. But I doubt if this is the style of farming that will ever become general in this country. Most of us are poor, and have to dig our money out of the land before we can spend it. We could farm much better if we had more capital—or, at any rate, we think we could. Perhaps if the Deacon and I had a couple of farms of 800 acres each, all paid for, and \$200 an acre working capital, we should not get up quite so early in the morning, or look so sharp after the men, or attend so closely to the details of the farm, or look to the state of the flocks and herds, as we are compelled to do now.

After lunch on the lawn, carriages and wagons, provided with seats, and drawn by Clydesdale horses, drove to the house. Mr. Crozier mounted his horse, Mr. Delamater drove one of the wagons, and we started to see the farm. Here is a thirty-acre field of clover and timothy, that had been cut a day or two before with three mowing machines. A two-horse tedding machine had been used to shake up the hay. It was then raked into windrows. Rain had fallen in the meantime, and now the tedding machine was going up and down the windrows at a sharp walk, and shaking up the hay, which dried so rapidly, that half a dozen men were following it, putting the hay in cocks for the night. The crop was a remarkably heavy one, I should think 2½ tons per acre, notwithstanding the fact that it was cut a week earlier than most of us here are in the habit of cutting our clover. It was capital hay. There was about two acres of the field, where the cocks stood far apart—so far, that I thought they might be rakings. I asked the Scotchman, who drove us, why this difference? "It was not manured," he replied, and this tells the whole story. Some 135 head of cattle are kept on the farm, 100 sheep, 50 to 100 pigs, and 35 horses. Sea-weed is gathered in large quantities, muck is thrown up in the winter, and when dry, is drawn to the yards to absorb the liquid and to be composted with manure. Large quantities of leaves are gathered for bedding, and I take it, though nothing was said on this point, that the bills for corn-meal, oil-cake, and bran, are not small. But all this time the procession is moving on. There is a bluff commanding a fine view of the Sound, and the distant shores of Connecticut. The field is in orchard grass and clover, ready for the machine, but we marched straight through it. The Deacon would have thought we were a set

of vandals, and he would have been greatly shocked when we came to a large field of rye, to see Mr. Crozier ride right into it, followed by the whole cavalcade, wagons with four-inch tires, carriages and all, sometimes two or three abreast, and wheeling round on the top of the hill, and marching back again. I hope Beacon Stock Farm does not often have such a set of visitors, or that the man who cuts that rye is not given to the use of strong language.

We passed a field of about 25 acres of mangel wurzel. They were as good, but no better, than my own—which was a consolation. They are sown on ridges, 2½ feet apart, and thinned out to 15 inches in the rows. The seed is drilled in with a Scotch, English, or Canadian drill (I did not ask which), four to six lbs. to the acre, the drill sowing two rows at a time. Some one remarked that the mangels were thin. "Did you ever see a thin crop of mangels," replied Mr. Crozier, "that was not a good crop?" It would not have been polite to have told him that I had. We want to have the plants come thick, and then thin them out to the desired distance—12 to 18 inches, according to the variety. Undoubtedly a great many crops are injured by leaving the plants too thick, and this was what Mr. Crozier meant.

There was also a magnificent field of sown corn for fodder. It was sown in rows, about 3 feet apart, and kept clean by the free use of the cultivator. The rows were as straight as an arrow. Mr. Crozier sets us all a good example in regard to straight furrows. I wish I could get my plowing done in this fashion. Mr. Crozier thinks we should have Scotch plows. I think it is due to Scotch or English plowmen, and not to the plows. I have got a Scotch plow on my farm, and it has lain under the shed for eight years. We like a Collins, or a Remington steel-plow much better. Still, I have no doubt that where the land is free from stumps and stones, there is an advantage in having long-handled plows. If so, our manufacturers can furnish them. There ought to be no need of sending to Scotland for plows.

The secret of Mr. Crozier's success can be told in two words: Capital and manure. It is not Scotch plows, or Scotch harrows, or even the Scotch "grubber," (which, however, struck me as the best implement on the farm, and one which I wish some of our manufacturers would introduce). It is manure. I would like to spend a week with Mr. Crozier, and study the details of his management. We know the value of manure, but few of us know how to make enough of it.

Edam Cheese.

Holland has been noted for the excellence of its dairy products for centuries. Its rich pastures, formed from lands which have been reclaimed from the bed of the sea, and which are in many cases far below its level, being preserved from overflow by broad high embankments, called dykes, support herds of the finest dairy cows. Dutch butter has a reputation second to none in the world, but it is for its cheese manufacture that Holland is most noted, and for which it enjoys an extensive demand.

Edam is a town of Holland, near the well-known Zuyder Zee, and about 12 miles north-east of Amsterdam. This town is the center of the manufacture of those nearly globular reddish colored cheeses, which are largely imported into this country, and sold in all the large cities

at from 30 to 40 cents a pound. Edam cheese, designed specially for exportation to foreign countries, is carefully made and will keep several years. It is, therefore, a favorite cheese for use upon ships making long voyages, and is almost the only cheese which is exported to India, China, and Australia. The fact that the American dairy factory system is being introduced into Holland, as well as into other European countries, and is thus made a means for more active competition with our own dairy products, would naturally make it desirable for us to learn everything possible as to their methods of manufacture, that we may, as far as may be, repay ourselves in kind for what we have bestowed, and not allow ourselves to be beaten with our own weapons in the dairy markets of the world. We have already taken the first place as makers of standard cheese, and favorably compete in the English market with English dairies. What is now necessary to enlarge our dairy business, is to succeed in the manufacture of fancy cheese, and secure the market for those kinds which cost but little more than common cheese to make, and sell for double and treble its price. There is a demand for small cheeses of high flavor, and the Edam cheese to some extent fills this demand. It is a cheese of three or four pounds weight, with a sharp, almost pungent, yet agreeable flavor, and, as we have already said, will keep for years. The process of manufacture, as described by M. Le Senechal, director of the dairy of St. Angeau, in Holland, is as follows: As the peculiar purposes for which this cheese is destined forbid the use of too rich a milk, and the presence of too much cream or butter in the curd, it is usual at the height of the season—that is from the middle of August to the middle of October—to skim from one-third to a half of the milk; at other times the whole milk is used. The milk brought to a proper condition as to richness, is placed in the vat, and raised to a temperature of about 90 to 92 degrees in summer, and 92 to 95 degrees in winter, when the rennet is added in the proportion of a quarter of a pint to 100 quarts of milk, or somewhat less, according to circumstances. The desired color, a light yellow, is produced by the admixture of a portion of annatto, the quantity depending upon the season, the richness of the milk, the quality of the pasture, and other incidental circumstances, which the skilled dairyman so well understands. The usual quantity is a tea-spoonful of a liquid preparation of annatto to a quarter of a pint of rennet. The liquid annatto used in Holland is about the same as that used in the New York factories. The rennet and coloring matter having been added to the milk, it is stirred for one minute and left to rest.

As soon as the curd is thoroughly set, it is cut into small fragments with a curd-knife, made of a number of fine wires fixed in a frame. This is done very carefully, lest the cream in the curd might escape into the whey and be lost. The curd is then gathered into a mass and freed from the whey, after which it is pressed by the hands into the molds, as shown in figure 1. In this process the workman fills each hand with curd and presses it together, reducing it to a soft cake, which he throws with force into the bottom of the mold. He repeats this process until the mold is filled, when the mass of curd is pressed together and taken out, and reversed three or four times until it is compact. The small holes seen at the bottom of the mold, in fig. 1, are kept clean to permit the whey to drain off. As soon as

the cheese is sufficiently pressed with the hands, it is taken from the mold and plunged into a bath of whey heated up to 122 degrees, for a space of two minutes. It is then again pressed into the mold, and shaped, wrapped in a fine cloth, replaced in the mold, and put in the press, the form of which is shown at figure 2. There is a great variety of presses used in Holland, the one here illustrated is that which is used at this dairy. The cheese remains in the press one or two hours in the winter, six or seven hours in spring, and about twelve hours in the summer. After coming from the press,



Fig. 1.—PRESSING INTO MOLDS.

the cheese is taken from the mold, freed from the cloth, and placed in the salting mold, seen at figure 3. This is intended to give the cheeses their final shape, which is nearly globular. The first day the upper surface of the cheese is sprinkled with salt, and the molds are placed in long, covered boxes, shown at figure 4, which are slightly inclined, so as to allow the whey, which drains from the cheese, to pass off through spaces in the bottom. These boxes are placed upon a stage. The second day the cheeses are taken from the molds, and rolled in a bowl filled with damp salt, and re-



Fig. 3.

turned to the mold, but in a reversed position. This process is continued until the salt has penetrated the cheese thoroughly; this happens in nine or ten days. The cheese, which has now become solid, is taken from the mold,

dipped once more in moist salt, wiped dry, and placed upon the drying shelves to cure. The shelves are arranged as seen in figure 5, and the cheeses are placed upon them in regular order,



Fig. 4.—BOX FOR EDAM CHEESE.

according to their age. Here they remain three months, being turned every day the first month, every second day the second month, and once a week during the third month. At the end of 24 to 30 days, they are dipped in a bath of tepid water (about 66 to 70 degrees), washed, brushed, and set to dry in an open place. When perfectly dry, they are replaced upon the shelves. Fifteen days afterwards they are again washed, dried, and greased with linseed oil, when they are returned to the shelves where they remain until sold for home consumption. When prepared for exportation, they undergo some further processes, to give them a lighter color upon the outside, and also to preserve them for a longer period. They are first scraped smoothly with a sharp knife, then, for the English and Spanish markets, they are rubbed with a mixture of linseed oil and annatto, which gives them a deep orange color. For the French market, or for shipment by sea, they are dipped in a bath of 6 parts of tincture of tournesol (*crozophora tinctoria*), one half part of Berlin rouge, and 10 parts of water. 36 lbs. of this preparation, costing \$2.50, is sufficient to color 1,000 cheeses. When the surface of the cheeses is dry, they are rubbed again with

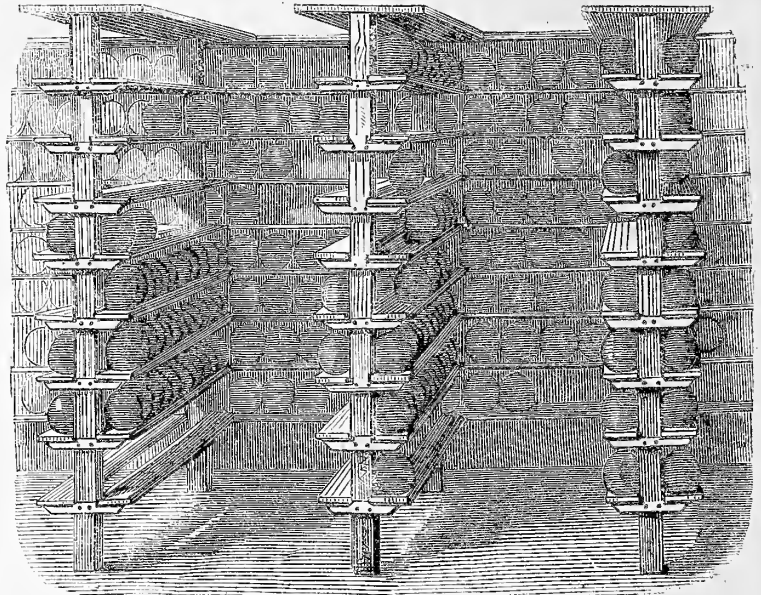

Fig. 5.—CURING-ROOM FOR EDAM CHEESE.

the hot climates of the tropics. The chief necessities in curing these cheeses are dry air, a regular temperature of about 72 at every season, a current of pure air through the curing rooms, careful avoidance of damp air, on which account the north, north-east and east winds, which in Holland blow from the sea, are considered eminently injurious. The colstrum, or the first milk of a fresh cow, is unfit for use, and if the cows have been heated previous to milking, it is considered preferable to lose the milk than to use it for cheese. The Edam cheese manufacture is the most profitable of any in Holland, yielding about one-

fourth more than any other. 100 pounds of milk produce 10 to 11 pounds of cheese, which sells at the dairy for 16 cents a pound (160 francs the 100 kilogrames).

A Machine-made Ox-Shoe.

By reason of the excessive cost of a hand-made shoe, it is frequently the case that shoes remain on an ox, when they should be taken off and replaced, or the ox goes unshod, in either case to the discomfort or injury of the animal. Many an ox is tortured throughout the summer season, and compelled to work with tender feet upon stony roads, doing only half work in the meantime, simply because it will cost \$8 to \$12, and the loss of a day's time, to get him shod. Besides, the making of a good ox-shoe is a specialty, in which few blacksmiths are perfect, and one is often obliged, as we have been, to go ten miles from home to get an ox shod. Now we are glad to know this difficulty and cost may be avoided by the use of an improved machine-made, forged shoe, which is manufactured by the Greenfield Tool Company, of Greenfield, Mass., for the reasonable price of 15 cents per pound. The illustration shows the character of this shoe. It is an engraving of one half of the



MACHINE OX-SHOE.

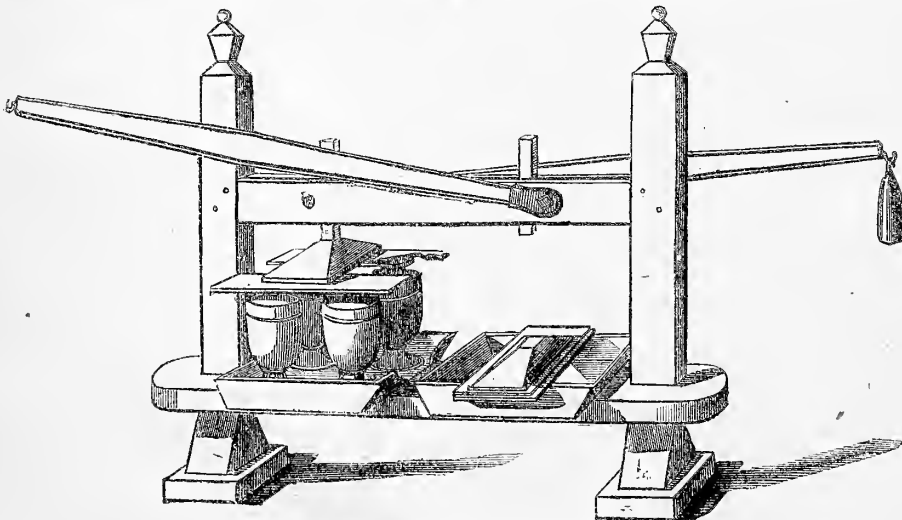

Fig. 2.—PRESS FOR EDAM CHEESE.

butter mixed with rouge, and packed in boxes of eight compartments, each one of which holds a cheese. They are now ready for shipment, and in this condition may be preserved for several years without deterioration, even in

turned to the mold, but in a reversed position. This process is continued until the salt has penetrated the cheese thoroughly; this happens in nine or ten days. The cheese, which has now become solid, is taken from the mold,

turned to the mold, but in a reversed position. This process is continued until the salt has penetrated the cheese thoroughly; this happens in nine or ten days. The cheese, which has now become solid, is taken from the mold,

shoe, and is a little more than one-third the full size of the number 3-shoe, which weighs eight pounds the set of eight pair, a full set thus costing only \$1.20. These shoes are made of four sizes, six, seven, eight, and ten pounds the set, and are made wholly by machinery, the dies giving the necessary concavity to the shoe, to make it fit perfectly, and cover the ball of the foot without pressure. This is a very difficult thing to do with the hammer, and is a special feature of this shoe, the dies being patented. These shoes, fitting the foot perfectly, cling thereto much longer than a hand-made shoe, which rarely fits the foot, and besides they are so readily fitted, if the proper size is procured, that it is an easy matter for a careful hand, who can drive a nail in the place he wants to put it, to shoe an ox.

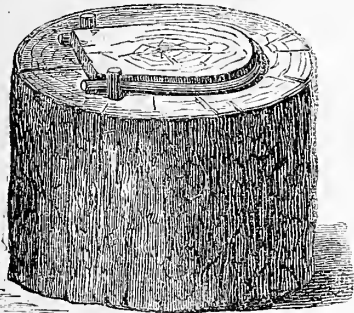

MOLD FOR OX-BOW

How to Bend an Ox-Bow.

Ox-bows may be given their permanent shape by such a mold as we here illustrate. It may be made of a piece of two-inch plank, cut to the shape desired to give to the bows, and pinned upon another piece of plank, or the end of a block, as here shown. A hole is bored on each side of the mold, into which pins are placed, to hold the bow firmly while it is receiving the set. The wood for the bow, after having been dressed to a proper shape, is soaked in water, and heated before a fire, by which it is rendered flexible; or it may be steamed in a steam-box, or soaked in a trough in boiling water. When the bow has remained in the mold until it is dry, it is removed, and the ends are tied together with a cord, to keep it in shape. It should be hung up in a dry place until used.

Sour-Fodder-making in Hungary.

The chief necessity of every dairy farm, or cheese and butter factory, is to feed a juicy

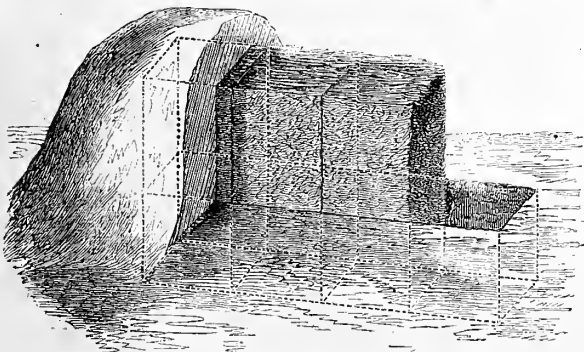

FIT OF SOUR-FODDER.

food to the cows at every season of the year; this is easily provided for in the spring, summer, and autumn, by feeding green rye, wheat, clover, a mixture of oats and peas, corn, etc., but in the winter we have no other milk-producing fod-

der than beets and corn-sour-hay. It is known to every farmer, how difficult is the preserving of roots in the winter, and that large quantities of them are injured and therefore spoil. To avoid this, we cure the beets and other roots with chaff into sour-fodder. This method of using root-fodder has been in use on large farms in Hungary for some years, and has always been successful. The method of making this so-called sour-fodder is as follows: at first we have a ditch made in a dry place; the ditch may be of the same dimensions, as was described for making sour-hay in the *Agriculturist* for October, 1873. When the beets are taken up in the usual manner, they are hauled in, washed, and cut with a machine. Then the pit may be divided into sections, for instance, for a length of ten rods into five sections, and by this division the labor is very much facilitated, because the first section can be covered with earth, while the second section is being filled. When a certain quantity of beets are cut, we place at first a layer of chaff upon the ground of the first section, upon this chaff is placed a layer of cut beets, in the proportion of one pound of chaff to ten pounds of cut beets; these two layers are then solidly mixed with a fork after having done so, a layer of chaff and beets is again laid down, and again well mixed. This is repeated until the mixture reaches the top of the ditch; then it must be built upward from six to nine feet above the level of the ground. On the top of the stack are laid a few sheaves of rye-straw, to prevent the fodder being mixed with earth; then the first section is covered with earth, commencing the covering at first on the top of the stack. When the first section is finished, the second and all following sections are managed in the same manner, as above described; when the whole ditch is filled, we take care that the stack is covered on every side with 1½ to 2 feet of earth. This sour-fodder, mixed with corn-meal or other feed, will be relished by the daintiest beast. The engraving shows the whole arrangement. The first and second section of the ditch is filled, the first one is also covered with earth.

Albrechtsfeld, Hungary. G. C.

[Although the fodder above described is called sour-fodder, yet it is not on that account objectionable; the fermentation, which the feed undergoes, produces some ammonia, so that really the mixture is to some extent alkaline, and this corrects any ill effects which might be supposed liable to arise from the acidity of the food. By the same process brewers' grains may be preserved for use during the winter, alone or with cut straw.]

A Convenient Barn for Sheep.

Unless sheep are carefully provided for, there is sure to be trouble and loss in the flock. It is probably for the reason that a single sheep is not worth much, and that they are ignorantly supposed to exist without water, or any fodder, but the waste of the feeding yard, and to thrive the better the more they are exposed to the weather, and to pine away the faster the more they are coddled, that so many of them are lost every year, and that so few farmers

succeed with them. But if we figure up how much money may be made, by good care, yearly out of \$100 invested in sheep, as compared with the profit from \$100 invested in cows, or a mare, the balance will be greatly in favor of the sheep. As an illustration of what may easily be done by any farmer, who will take the trouble, we give an account of the cost of,

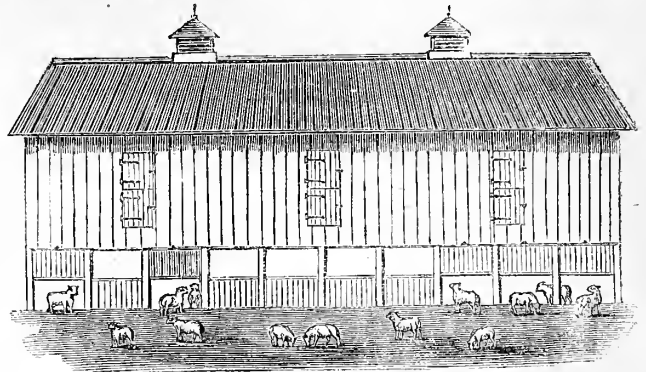

Fig. 1.—FRONT ELEVATION OF SHEEP-BARN.

and receipts from, a flock of 55 common ewes, picked out of a drove, which was passing the writer's farm on its way to market, in the summer of 1868. The sheep were purchased at \$3 per head, and until winter were pastured in a rough field at the rear of the farm, where they more than earned their keep and care, by the service they performed. The account for one year, opened and kept expressly for this flock, is as follows:

Dr.	
Cost of 55 sheep	\$165.00
Value of hay, straw, stalks, turnips, bran, meal, and oil-cake, fed	205.84
Freight and charges on 24 lambs	7.92
Balance of profit and loss	145.64
\$524.40	
CR.	
24 early lambs sold at from \$7 @ \$10 each	\$192.00
8 lambs, @ \$4.50	36.00
12 lambs, @ \$3.50	42.00
8 lambs kept, @ 4.00	32.00
9 lbs. pulled wool, @ 30c	2.70
182 lbs. wool, @ 35c	63.70
52 sheep on hand (3 killed by dogs)	156.00
\$524.40	

This leaves a profit of nearly 100 per cent on the original cost of the sheep, and in addition a large pile of valuable manure, of which no account was kept; besides, some of

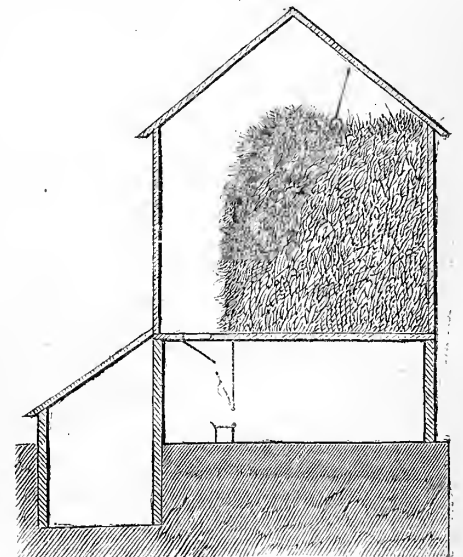

Fig. 2.—SIDE-SECTION OF BARN.

the ewes could have been sold in the spring at \$5 or \$6 each, to the butcher, but we had use for them for another year. The next year's account would have been more favorable still,

as all the lambs would have come in to sell early at the highest prices, but for a disastrous raid by the village dogs at an unguarded moment which all but destroyed the whole flock. But this disaster only exemplifies more clearly the point we desire to show, which is, that the greatest care (even against such a contingency as an attack by dogs), gives the greatest profit. It is during the winter season, that the most care and skill are needed, and but little success can be had without a good sheep barn. Such a barn, having many conveniences both for the flock and their owner, is here illustrated. It consists of a barn, shown at figure 1, about 20 feet wide, 16 feet high from basement to eaves, and as long as is desirable. This is intended to store the hay or fodder. The posts, sills, and plates are all 8 inches square, the girts and braces are 4 inches square, the beams 2 x 10, are placed 16 inches apart, and are cross-bridged with strips, 3 inches wide. The hay is piled inside, so that a passage-way is left over the feed-passage below, in which there are trap-doors. The hay is thrown down through these doors, and falls upon a sloping shelf, which carries it into the feed-racks below, (see fig. 2). The basement under the barn is 8 feet high, and is of stone on three sides; the front is supported by posts, 8 inches square, and 8 feet apart. Between each pair of posts a door is hung upon pins, (fig. 3,) which fits into grooves in the posts, so that the door may be raised and fastened, so as to close the upper half of the space between the posts, or held suspended half way, leaving the whole open, or be shut down and close the lower half, or be removed altogether. By this contrivance at least half the front of the basement must be

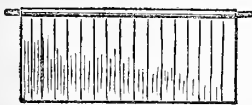

Fig. 3.—Door.

left open, whether the sheep be shut in or out. The floor of the basement should be slightly sloping from rear to front, so that it will always be dry. Fig. 4 shows the plan of the basement. The feed-passage is shown at *c*; the stairway to the root-cellar at *b*, and the root-cellar at *a*. Fig. 2 gives a section of the whole barn. The hay-loft is above, and the passage-way and the doors are seen, by which the hay is thrown down to the feed-racks below. The sloping shelf, by which the hay is carried into the feed-racks, is shown. Below the feed-rack is the feed-trough for roots or meal. A door shuts off this trough from the sheep at the front, while the feed is being prepared, and when it is ready, the door is raised, and held up by a strap or a hook to the feed-rack. The feed-rack is closely boarded behind, and this back part, which is in the feed-passage, slopes forward to the front, so as to carry the hay forward to the bottom. The front of the rack is of upright slats, smoothly dressed, two inches wide, and placed three inches apart.

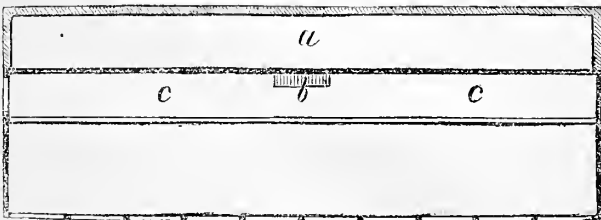

Fig. 4.—PLAN OF BASEMENT TO SHEEP-BARN.

The boards of the feed-trough are smoothly dressed and sand-papered, and all the edges are rounded, so that there is nothing by which the wool may be torn or rubbed off from the sheep's necks. It will be seen by this

arrangement, that there is no dangerous thing by which a sheep or a lamb might be hurt, or place where it can get into mischief. The root-cellar is at the rear of the basement, and is reached by the stairs already mentioned. After having tried several different plans for sheep barns, we think this combines more conveniences than any other we know of. A barn, large enough to accommodate 100 sheep, may be built for \$500 to \$600, and the yearly interest on this sum would alone be paid several times over in the saving of lambs, that would be lost without such shelter and conveniences.

On Siphons and Water-Pipes.

The failures of siphons when used to carry water long distances over a rise of ground, are mainly due to two causes, viz., the admission of air into the pipe and an excessive friction,

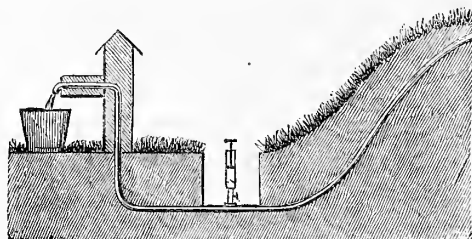

PUMP ATTACHED TO A SIPHON.

which greatly retards the current. The readiness with which a very small imperfection in the inner surface of a pipe will retard the flow, may be estimated when we learn that a mere scratch in the discharge nozzle of a steam fire-engine pipe, so small indeed as to be overlooked by the workmen who finished it, was sufficient to reduce the throwing power of the engine from 200 to 150 feet. This surprising effect of so small a cause could hardly be believed, were it not vouched for by so accurate a man as Professor Tyndall, at a recent lecture on "Liquids" at the Royal Institution of London. We can not wonder, then, that in the passage of water through 1,500 feet of half-inch pipe, the flow should be altogether arrested by the friction, and not even a drop be discharged at the lower end, except at intervals. It is, therefore, necessary, when small sizes are used, to exercise great care in selecting pipe for the conveyance of water, and in place of the common lead-pipe to use the tin-lined pipe, the inner surface of which is very smooth. This retardation of the flow in a siphon may cause air to enter the pipe, but a considerable quantity of air is always dissolved in water, or mixed with it, and in flowing through the pipe some of this air separates from the water, and gathers at the highest part of the curve, and as soon as the quantity collected is sufficient to fill the pipe for even an inch of its length, and the continuity of the stream of water is broken,

the current is disturbed, a constant gurgling of the air in the pipe is heard, and very soon the stream stops running. This is the chief difficulty complained of by several correspondents, who have asked for a remedy for the trouble. The remedies are, first, in procuring pipe for a siphon, that kind should be chosen which has the smoothest surface inside. Second, in laying the pipe it should be carefully straightened, and no sudden curves be made in it; nor should any parts of it, that may have been accidentally damaged or squeezed out of shape, be allowed

to remain, but they should either be brought to their proper form, or be cut out and the pipe joined again. It must be remembered that if the sides of a pipe are squeezed together, the capacity of the pipe is reduced less or more, according to the amount of flattening, and if one part an inch long is thus reduced in size, the capacity of the whole pipe is reduced. Third, in making the short bends at either end of the pipe, which may be necessary for any purpose, the greatest care should be exercised to avoid flattening the pipe. A perfect bend may be made by pouring fine sand, made dry by heating it in an oven, into the pipe, until the part to be bent is completely filled. Then a perfect bend may be made without reducing the diameter of the pipe in the least. The dry sand may be very easily run out of the pipe afterwards. Fourth, after all these preventive measures have been carefully applied, and the pipe is laid, a method of removing the air may be used as follows: a piece of the pipe should be soldered near the lower end, and a common brass-tap fitted to it. A chamber is to be made in the ground, to contain this upright piece of pipe and tap. A screw is also soldered to the end of the piece of pipe, by which a small double-valved syringe or pump, with a discharge for the water, may be attached. When the presence of air is suspected or known in the pipe, this small pump is screwed on to the end of the upright piece, the tap is opened, a plug is fitted into the end of the water-pipe, and the small pump rapidly worked. The greatly increased flow brings down with it all the air that may have collected in the upper part of the pipe, the plug is removed, the tap shut, the pump unscrewed, and all goes well again. The proceeding occupies less time that is needed to describe it. The method is here illustrated. The engraving shows the chamber, with the arrangement of the pipe, tap, etc., and also the part of pump that is needed, which may be a very cheap one.

The Outlet to a Swamp.

BY GEORGE E. WARING, JR., OF OGDEN FARM.

I have recently been employed to do the engineering of a piece of swamp draining in East-

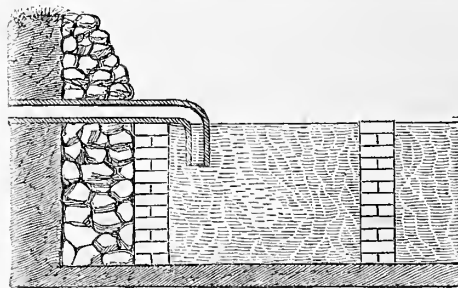

OUTLET TO A SWAMP-DRAIN.

ern Massachusetts, and as the case presents difficulties, which are very common, it will perhaps interest others to know how the work is being done. The swamp is in a "pocket," and was originally a pond. It was drained by a stone trunk-drain, about 900 feet long, much of which was twenty feet deep. To make such a drain at the present price of labor, would cost \$1,500, as the digging was very difficult. The cost of making the huge stone-drain, which was many times larger than necessary, was so great, that distance was very important, and the straightest practicable line was followed. True to the nature of all stone-drains, this one, after twenty years use, has gone to the

bad. It has caved in, and become choked with surface rubbish, until it is nearly useless, and the swamp is returning to its condition of a stagnant pond.

The area to be drained is only about ten acres, but it lies directly in front of a fine residence, and must be made dry without regard to the agricultural value of the improvement. I find that by following a devious line, and increasing the length to about 1,100 feet, the drain can be made with very much less cutting, and through less difficult ground. The average cut will be about 8 feet, a small tunnel being made under a road where before it was necessary to cut 21 feet deep and 5 feet wide on the average.

The drain will be laid with 6-inch drain tiles, and the whole cost will not exceed \$450. This will secure an absolutely permanent drain, costing, with interest at present rates, say \$35 per annum. The \$1,500 stone-drain has become worthless in about twenty years. It has cost—interest and depreciation—about \$150 per annum.

The outlet of this drain will be protected by cheap masonry, and a grate to exclude vermin. The great point of danger is the *inlet*. Mud and floating rubbish must be kept out, or the whole drain may become worthless. This will be prevented by the arrangement shown in the illustration. At the side of the swamp toward the outlet, there will be a stout retaining wall of rough stone-work, to support the earth needed to protect the tile. Adjoining this will be a round well of brick or stone, 4 feet in diameter and 3 feet deep. The top of the wall of this well will be level with the bottom of the tile where it passes over it, so that it will be the thickness of the tile, say $\frac{1}{2}$ inch, below the surface of the water. The upper end of the drain will be furnished with a curved joint of pipe, turning down about one foot into the water. Thus the inlet will be below the reach of floating rubbish, and well above the sediment which accumulates in the well, and which can be removed from time to time.

To secure the free admission of as much water as the tile is capable of carrying, the inlet will be 10 inches in diameter, narrowing to 6 inches within a few feet.

Arrangement for Hurdles.

As the season is at hand for hurdling sheep, we give the accompanying illustration and description of a method of placing the hurdles or nets, by which the least labor or length of hurdles or nets need to be used. We suppose a square field of 10 acres is to be fed off. The distance across the field is 220 yards. This is the least length of hurdles that can be used. But if the field is divided off into strips across, the whole of the hurdles must be moved each time, and if the field is divided into eight strips, there will be seven removals of every hurdle, or the whole length of netting. In the plan here shown, only half this work is necessary, and a field may be divided into eight sections by moving half the hurdles seven times. For instance, plot 1 is fed by placing the hurdles from *a* to *b*, and from *c* to *d*. Plot number 2 is

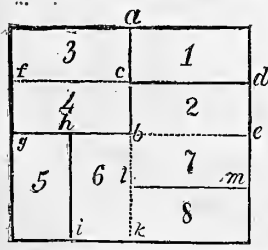

ARRANGEMENT OF HURDLES.

fed by moving the hurdles from *b* to *e*. The next setting of the hurdles is from *e* to *f*, the next from *b* to *g*, the next from *h* to *i*, the next from *b* to *h*, the next, and last, from *l* to *m*. There will be eight settings of 110 yards each, instead of seven of 220 yards each, which would be necessary, should the field be fed off in the usual manner of strips across it.

California Tobacco.

It would seem as though tobacco planting in California is destined to have a great influence upon the profit of the crop in the East. The planting is rapidly increasing in California, year by year, and the product is enormous. There are two or three cuttings in a season, and some planters speak of 4,000 pounds per acre, or more, as the yield of their plantings. One planter in Lake County, has nearly 300,000 plants set out this season, an incorporated company have a million plants set out in Los Angeles County, and nearly as many in Santa Cruz County. Besides these there are many other large planters, and more smaller ones. In addition to the large plantings and prolific yield, a process of curing is there practiced, by which the tobacco is quickly prepared for market, and its value increased. This is known as the Culp process, and is patented. The tobacco yet green is piled up and allowed to ferment and heat. The moisture is thus rapidly expelled, and the character and texture of the leaf is improved. If the anticipations in which the California tobacco growers freely indulge, are only partly verified, it will give rise to a serious competition, which Eastern growers may find too formidable to resist. If this should be the result, however, we do not think there is any reason for regret, as we believe Eastern farmers will find, in the long run, wheat, corn, and grass, to be more profitable to themselves and their land than tobacco.

Cramming Poultry.

It is altogether a vitiated taste that creates a demand for over-fattened meat. There is no nutriment in fat, and with the large consumption of sugar, syrup, and starchy food, that is common among us, the necessities of the system for carbonaceous food are fully, if not over supplied. The use of excessively fat food then is a waste of material, and it probably induces some of the bilious disorders which are so common. With regard to poultry these remarks are especially applicable. The markets of the cities are filled with fowls that are lined with fat, a useless addition that is a loss to the consumer, and its production has been at the expense of a waste of food to the feeder. Besides, housekeepers complain of these over fat fowls, that they are deficient in delicacy of flavor, and are coarse and greasy, thus losing in quality as well as in weight. This matter is in the hands of farmers themselves to remedy. They alone decide as to what degree of fatness their fowls shall be brought, or rather, not knowing exactly how fat they are, they continue to feed them much too long for their own profit. A very thin fowl can be brought into good condition for the table by three weeks' feeding. Generally a fowl from a grain-stubble or a barn-yard at a time when waste grain is scattered about liberally, as well as at other times, when the housewife undertakes the feeding of the poultry, is sufficiently fat for the

market, without extra feed. If poultry is marketed at the age of two years, and none older than that kept, the quality of the flesh will be all that can be desired, without any cramming or extra feed, and the extra fat that is laid upon an old fowl, is no addition to its goodness, but rather adds to its bad qualities. A good judge of poultry looks to the age of a fowl, and passes by the old birds that have been crammed to fit them for market.

The Transportation Problem—Steam on Canals.

Transportation by water has ever been, and probably ever will be, the cheapest method of moving heavy freight. Natural water-ways, such as oceans, lakes, and rivers, are obviously the cheapest of all, as they cost nothing to construct, and next to these come canals, which are simply artificial rivers. It remains then only to provide the most economical mode of carrying freight upon these natural or artificial water-ways, to secure the cheapest system of transportation. But while this general proposition is simple enough, there are other considerations which affect the question and give rise to difficulties, which give to this seemingly simple business the character of a problem. For instance, there is the storage and transfer of grain and other produce in the west, the transfer of freight from lake vessels to railroad cars, and canal boats, the intermediate and temporary storage when that is necessary, the conveyance, heretofore necessarily slow, upon the canals, and the final disposition of the freight when it has reached tide water, and is awaiting shipment. All these matters involve delay and cost, and it is upon the perfect management of each, and the economical working of the whole together, that the final successful solution of the transportation problem depends. That system which will use the means we have in such a manner as shall cost the least money to the shipper of the freight, will be the best possible one. The time occupied in the transit of produce is a large element of cost, because time is money, and every hour's unnecessary delay adds to the expense. In the water-route from the lake-ports to those of the Atlantic, there has been hitherto a link, or rather a break, consisting of the Erie and other canals, which has added greatly to the cost of transporting grain, as compared with what that cost would have been could this break have been avoided. This weak link, or break, in the continuity of the routes, of comparatively insignificant length, caused the greater part of the expense of shipping a cargo of grain from the west to the east, by reason of the slow transit of freight upon it. It has, therefore, been a matter of great interest to have the canal system so improved, that it should be made equally economical with the lakes and the Hudson river. The use of steam in place of horse-power has long been viewed as the chief improvement to be made, and the State of New York, the owner of the canals, offered a premium of \$100,000 to the inventor of the steam canal-boat, which should succeed in transporting freight at the minimum of cost. In the competition for this prize last season, several boats of different construction were presented. The most successful of these, and that which made the most rapid trips at the least cost, was a boat designed and built by Mr. William Baxter, of Newark, N. J., the inventor also of one of the most compact, safe, elegant,

and economical, portable steam-engines as yet constructed, known as the Baxter steam-engine. The New York Legislature, at its last session, completed its share of an arrangement by

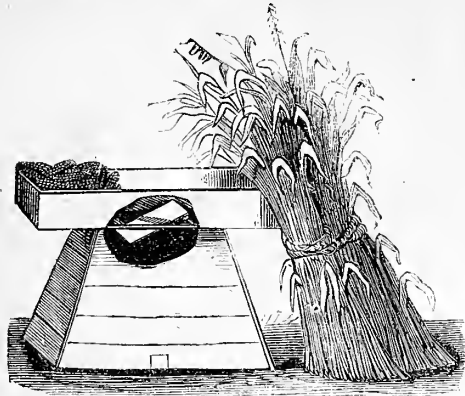

Fig. 1.—SIDE-VIEW OF TRAP.

which \$35,000 of the premium money is awarded to Mr. Baxter, on condition that 20 of his boats are placed upon the canal immediately. This will be done, and the present season will see steam navigation inaugurated, and the use of horses and mules dispensed with, or at least a beginning made towards this desired result.

The economy of this new system is great, and will largely reduce the total cost of grain transportation. The official report of the trials of the Baxter canal-boat credits it with a speed of 31 miles in 10 hours, or 74 miles in 24 hours, with the almost incredibly small consumption of less than 15 pounds of coal per mile, when carrying 200 tons of freight. The speed is doubled, and the cost of carriage is reduced one-half, which makes the cost of freight by these boats only about one-fourth that of the boats drawn by horses. The Commissioners who superintended the trials, estimate the saving on the business of the Erie canal alone at four millions of dollars, and on all the canals of the country at ten millions of dollars. Besides, as two tons can be carried over the canals where one was carried before, without extra expense, the value of the canals, just as soon as the new boats can be made to replace the old ones, will be doubled. It is difficult to estimate the advantage which the agricultural interest will gain from this improvement, but it is well worth while to consider, especially at the present moment, how this interest is dependent upon the ingenuity of inventors, the skillful labors of mechanics, and the beneficent uses of capital. Without either of these, or all of them combined, the agricultural interest would depend solely upon itself, and in that sole self-dependence would be reduced to insignificance and helplessness. How closely every industrial interest is bound up with the thoughtful brain of the inventor, and both

with capital, which is only another term for accumulated work or industry, is here very clearly shown. The Baxter canal-boat, as may be seen in our illustration, is not very different from an ordinary boat in its capacity or construction, except that it carries its own motive power in the hold. With the contemplated enlargement of the canals, increased efficiency will be given to steam transportation.

A Permanent Rat-Trap.

It is hardly safe to venture an estimate of the amount of grain yearly destroyed by rats, because we might be so far under the mark. We know a case in which the corn crop of a field of 13 acres was put away into a mow with the cars on, so that it might be cut up together and steamed for the stock, and three-fourths of it was destroyed by the rats, and rendered useless. This is an extreme case, but the damage to corn in eribs and unthreshed grain in barns is vastly greater than farmers generally suspect. It is true that these pests are hard to get rid of, that they are sagacious and cunning, and that their perseverance is remarkable. But a man should know more than a rat, and he has but to exercise equal perseverance with these enemies to vanquish them. Where it is possible, the best thing to do, is to remove every hiding place by elevating the buildings upon posts or pillars of brick or stone, and letting daylight beneath them.

outhouse, or a quiet part of a barn or stable. It consists of a long narrow box, three or four feet long, and six or eight inches wide and deep. This is set upon another box about 30

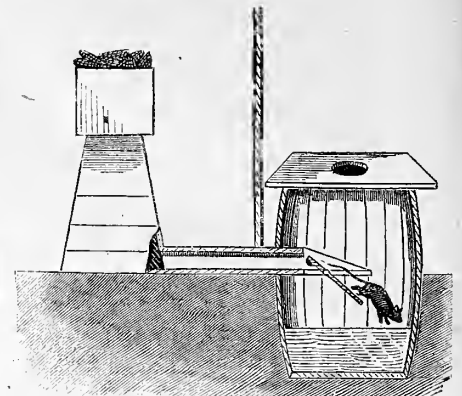
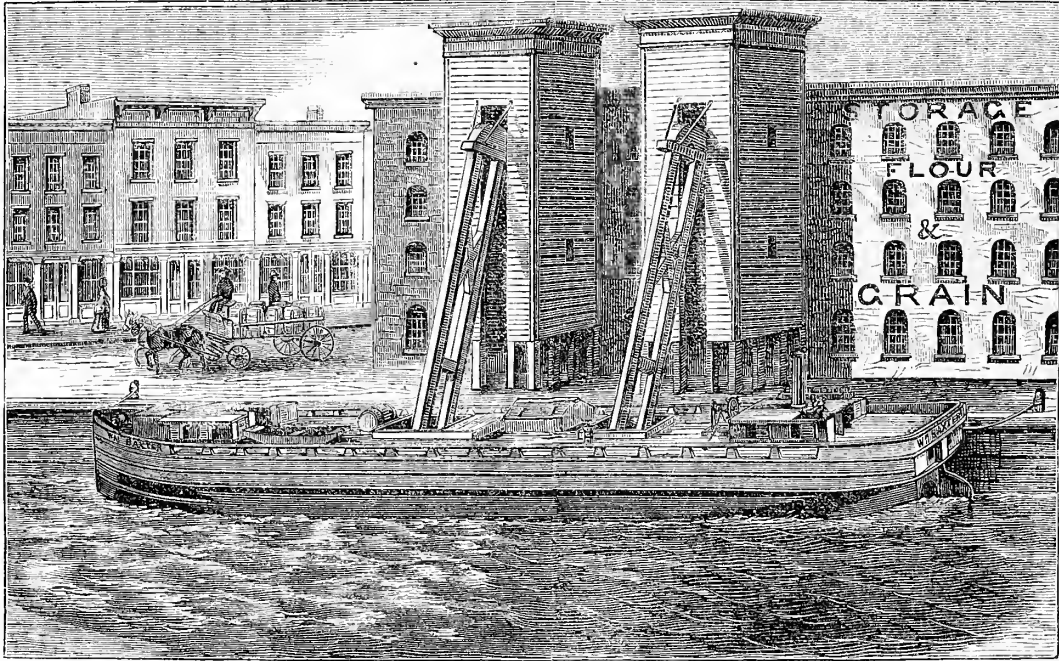

Fig. 2.—SECTION OF TRAP.

inches high, with sloping sides, so that the first box forms the top part of the second box; the first box is open at the top for about a foot at the rear end; all this is seen at fig. 1. This open part is partly filled with corn or corn ears. Immediately in front of this part there is a loose bottom neatly fitted upon pins, so that it will open downwards with the weight of a rat. A piece of lead is fastened to it to keep it in position, or restore it to its place after it has been disturbed. The front of the box is partly hidden with a couple of sheaves of corn stalks or rye straw which furnish a ready means of access for the rats. At the bottom of the second box there is a narrow box or tube fitted, which leads through the wall of the building into a barrel half sunk into the ground outside, as shown in fig. 2. A loose trap is also fitted at the end of the tube. The barrel is covered with a wide board with a hole in the center to admit the light. A few pails full of water are put into the barrel. At first the loose bottom is pegged fast and the rats



BAXTER'S PRIZE STEAM CANAL-BOAT.

Rats love darkness, and will not harbor or breed in places where they are exposed to view. The pig-pens, which are favorite resorts for them, should be raised well up above the ground, and the pigs will be all the better for it. The stables should have paved floors, and the sills should be placed on a brick underpinning. The barn, if there is no basement, should be raised upon pillars or short walls two feet high, so that dogs or cats can get under them. If this can be done, and every rat that is seen is hunted down perseveringly until it is caught, the pests will desert the place as being unwholesome for them. Where thorough work is not possible, they may be induced to desert their quarters by one or two effectual raids made upon them by means of the contrivance which we here illustrate. It should be set up in an

quickly finding out the way to the corn, are allowed to gather there for a week or two, and are fed liberally. When they have taken full possession, the pegs are taken away, and the pivots are greased, and the rats are caught one after the other. As they find their way to the barrel, attracted there by the light, which they can see through the tube, they are drowned and their bodies may be scooped out daily. The number caught in this way is astonishing, and for a time afterwards few, if any, rats will be seen about the place. Then the pegs may be replaced, and the rats encouraged to gather again. The contrivance is a permanent one, and will pay for the attention it requires. It is not a new thing, and has been used with great success for many years, but is probably new to most of our readers.

Succulents as Decorative Plants.

BY CHARLES H. HOVEY, CAMBRIDGEPORT, MASS.

SECOND ARTICLE.

Among the succulents, the *Sempervivums*, next to the *Echeverias*, demand our attention as being the most useful—the hardy varieties for the garden, and the tender ones for both greenhouse and garden decoration. As indicated by the name *sempervivum*—"always liv-

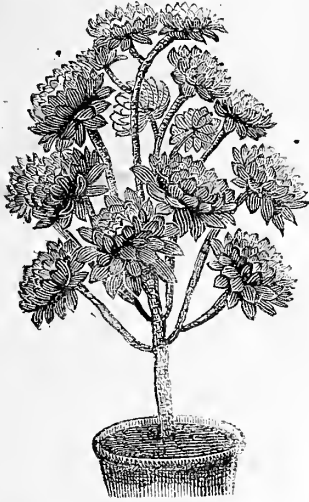

Fig. 1.—TREE HOUSE-LEEK.

ing"—they are extremely tenacious of life, appearing to stand equally well the hot and the cold, the wet and the dry weather, and increasing very rapidly. This genus is well known in the old House-leek, which, in Europe, was formerly grown by royal edict on the thatched roofs of houses, on account of its supposed power to avert lightning. The succulent leaves of this common species were formerly supposed to possess curative properties. There are very many species and varieties, hardy and tender; the hardy ones are all stemless, and present a great contrast in habit of growth, as well as in the color of their leaves and flowers. Many are worthy of cultivation from the effectiveness of their flowers alone.

For the edging of flower-beds, or figures, for lettering, or rock-work, and for edgings, the *Sempervivums* are in every way desirable.

The tender species differ greatly from each other in shape and style of growth, and are exceedingly ornamental for the greenhouse, as well as indispensable for the garden in making a bed of succulents, or if scattered among a group of miscellaneous plants, they give a certain novel and striking effect, which we find in no other class of plants. Most of them are



Fig. 2.—TABLE-FORMED HOUSE-LEEK.

very symmetrical in their growth, and form fine single specimens for the greenhouse; they vary in height from six inches to six feet.

Of the tender kinds the following are enumerated as a few of the most desirable: *Sempervivum arboreum*.—This (figure 1) is one of the best known; it has a regular tree-like growth, attaining the height of five or six feet. The leaves, of a light green, grow in rosettes upon the extremities of the branches.

S. arboreum rubrum is similar to the above in general appearance, except in the color of its leaves, which are deeply tinged with red.

S. arboreum variegatum.—Similar to the two preceding, the leaves being broadly margined with bright yellow, and green in the center. One of the finest variegated-leaved plants.

S. arboreum medio-luteum.—Another variegated form of *S. arboreum*, having the yellow variegation in the center of the leaf, upon each side of which is a margin of green.

S. tabulaforme.—This is the most distinct of the *Sempervivums*; it is called the Table-shaped *Sempervivum*, on account of its manner of growth. It is of dwarf habit, with its top perfectly flat, the leaves being as close together as if pressed. We have a specimen six inches high and ten inches in diameter, and as flat as a board, as in figure 2. A very desirable kind.

S. Canariense.—Somewhat similar to *S. tabulaforme* in growth, but with larger leaves than in that species, and the cluster is slightly concave.

S. Heworthii.—A dwarf, free branching species, producing small clusters of leaves at the extremities of the branches, the plant forming one large round cluster of small tufts.

S. Youngianum.—A tree-shaped variety, with very wide, flat leaves, somewhat after the style of *S. tabulaforme*. Very distinct.

S. decorum, *S. ciliare*, *S. glutinosum*, *S. rubicum*, and *S. cholochrysum*, are all very good kinds, and worthy a place in any collection.

Of the hardy *Sempervivums*, those which are

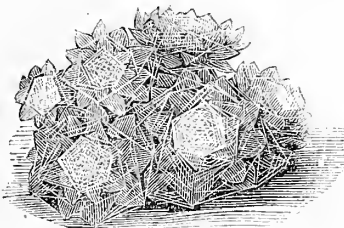

Fig. 3.—COBWEB HOUSE-LEEK.

most distinct and desirable, are the following:

S. arachnoideum.—This, called the Cobweb *Sempervivum*, is one of the most curious species; it has the peculiarity of being completely covered and interwoven from tip to tip of the leaves with filaments like a spider's web. It grows in very compact clumps, as shown in figure 3, and gives a very striking effect.

S. tomentosum, and *S. Lagerrii*, present the same peculiarity as *S. arachnoideum*, though in a less marked degree. The leaves of both are green, but in *S. tomentosum* they change to a dull red in the spring; both are desirable.

S. calcaratum, improperly known in collections as *S. Californicum*, is one of the best of all the hardy species; its leaves are bright-green, deeply tipped with red. Fine for bedding.

S. soboliferum is called the "hen and chickens," for the reason that the young plants which it produces, are as regularly placed around the old rosette as if planted by hand. *S. hirtum*, shown in figure 4, as also *S. tomentosum*, present the same peculiar growth.

S. tectorum.—This is the regular roof House-leek before alluded to. A large and remarkably robust grower and a distinct species.

S. umbilicum chrysanthum.—This is very dwarf and branching, producing a number of

small, round heads, with the leaves incurved.

Very distinct. We may here mention

S. acuminatum, *S. Braunii*, *S. globiferum*, *S.*



FREE-FLOWERING ANDROMEDA.

heterotrichum, *S. montanum*, *S. Pittoni*, *S. pilosella*, *S. Reginae Amalie*, and *S. violaceum*, as all distinct and good. There are some fifty more, all different and perfectly hardy, which present their peculiarities of growth and color more fully in the spring. The *Sempervivums*, as a whole, are very desirable. They are easily taken care of, requiring very little attention, especially the hardy ones, which, when once planted, are quite able to take care of themselves.

The Free-flowering Andromeda.

Andromeda is a beautiful name, which Linnaeus gave to a genus of charming plants. Later botanists, for reasons which seemed satisfactory to themselves, split up the genus into several new genera, and while some place the beautiful Free-flowering Andromeda, *A. floribunda*, in one of these newer genera, *Leucothoe*,

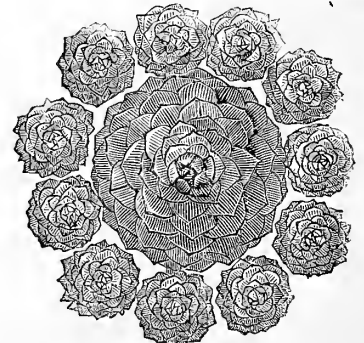

Fig. 4.—HAIRY HOUSE-LEEK.

and others in another, *Zenobia*, we are glad that our best American botanists, like Gray and Chapman, retain this as an *Andromeda*. Some of the *Andromedas* are deciduous, but this is an evergreen shrub, found from the mountains

of Virginia southward; it grows from two to ten feet high, and flowers even when only a foot high; it is very densely clothed with leaves, and on that account would be a desirable plant, did it not flower at all. The lance-oblong, acute leaves are about two inches long, with bristly teeth on their margins; the flowers are in large, dense, pyramidal clusters at the ends of the branches; the individual flowers are about the size of those of the huckleberry, contracted at the throat, five-angled, and of a pure white, which shows finely against the dark-green foliage. The racemes, or flower-clusters, are formed during the summer, and by winter appear almost ready to bloom; being so far perfected, a few warm days in spring cause them to open. Although the buds are so well advanced, the shrub is hardy in the climate of New York, and on account of its beauty of foliage and flower, would be a popular plant, could it be readily obtained. This *Andromeda* is a favorite in England, and failing to obtain it from our own nurserymen, we had to send to England for it.

Indeed, as strange as it may seem, the easiest way to get many of our native plants is to order them from abroad. Our nurserymen are not to be blamed for not keeping those things for which there is no demand; and with many buyers there is no surer way to condemn a plant, than to tell them it is a native. As to this plant, one may search a long while among the exotics before he finds a prettier early spring-blooming shrub. It can be propagated but slowly by layers, but more readily from young wood. Its slow growth may account for its not being in favor with our nurserymen, as buyers are unwilling to pay more for slow-growing things than for those that can be rapidly produced. In England this is a favorite plant for forcing; its well developed buds readily opening when the plant is brought into heat during the winter months. Much attention is given abroad to the decoration of dinner tables, and a well-shaped *Andromeda* in full bloom is a choice plant for this use. The plant seems to be about as patient of disturbance as a *Rhododendron*; of the half dozen received from England, a part had bloomed in the box on the passage. The others flowered as soon as set out, and all grew away as if nothing had happened to them. The engraving is from one of these specimens, and about half the real size.

Notes from the Pines.

Several have asked what has become of my "notes." There has been a plenty to say, but I do not think it fair to occupy the floor every month, when there are others who wish to be heard. One trouble about these notes is, that your arrangements for printing require them to be written so far in advance of their publication, that matters of present interest become quite old by the time they reach the reader. For instance, I am obliged to write the notes that will appear in August, soon after the middle of June, as you say your "inside," whatever that may be, goes to press on the first of July. Now I would like to say a word about the

AMERICAN WISTARIA, but it will be quite out of date next August. As I look from the window of my "den" this warm June afternoon, I see a perfect horticultural exhibition on the gable-end of my barn: the doors to the

carriage-house and to the tool-room are both grandly wreathed, and the vine gracefully disports itself elsewhere. The Chinese *Wistaria* is deservedly popular, on account of the earliness of the large clusters of its purple flowers. I have it, and its varieties, but were I restricted to a choice, I would take the American, *Wistaria frutescens*, and its white variety, in preference to the foreigners. The Chinese *Wistaria* flowers as the leaves are just opening, there is an abundance of flowers, with a poverty of foliage, and the bloom is not of long duration. The American, on the other hand, bides until it has made a dense mass of well-developed foliage, and over this it hangs its clusters of flowers, which are much smaller in bunch and individual flower than the other; the clusters are more compact, the flowers of a firmer texture, of the most delicate lilac color, and charmingly fragrant. In addition to all these it is American, and while I think none the less of a plant, because it is exotic, I am trying, in my quiet way, to have other plants thought none the less of, because they are native. The genus, wherever it may come from, commemorates Doct. Caspar Wistar, an eminent surgeon and anatomist, of Philadelphia. . . . Now is the time for building and repairing greenhouses. I am sure there would be a hundred greenhouses, where there is now one, if the matter of heating were simplified. In the old way of heating by a flue, one must be constantly on the lookout, and be ready, if need be, to get up in the middle of the night, and attend to the fire. Hot-water apparatus is much more easily cared for, but for small houses has been too expensive for those of moderate means—and these are usually the most enthusiastic flower growers. When I built my greenhouse (24 x 11) last fall, I put in one of the

BASE-BURNER WATER-HEATERS, made by Hitchings & Co., 163 Crosby-st., New York. Although we had but little extreme weather last winter, I am sure the apparatus would have heated a house one-half larger, if not one twice as large; indeed, the great trouble with it was to keep the heat moderate enough for the greater part of the winter. It is no more trouble than an ordinary base-burner stove; in mild weather it needs attention only night and morning, but when it was quite cold, it was looked after at noon. In this heater Hitchings & Co. have done much toward solving the problem of heating small greenhouses, and it is not easy to conceive of an apparatus that will work more satisfactorily, with a less consumption of fuel. [This heater was described and figured in September, 1873.] . . . In laying out my place, I consulted the public so far, as to put a low fence along the road, and to line that with low-growing shrubs, some of which are in flower all through the season, and present a cheerful appearance to those who pass by. I know that this gratifies many people, for they often slacken their pace, and if any one is in sight, stop to ask the names of the plants. The pleasure from this is, however, quite neutralized by a set of pedestrian vandals, who reach over the fence, and break off my shrubs in the rudest manner. What shall I do? I can prosecute these heathens, for I know who they are, and thus make enemies who will annoy me in other ways; shall I put up a board fence, and hide my shrubs, or shall I move them all to the rear, and leave a naked front? I'm in a quandary. Another quandary of mine is: shall the coming man be a horticulturist? As it stands now, the insects are a little ahead, but what

will it be fifty years from now, if matters go on as at present. The saying that

"HORTICULTURE IS A WAR WITH INSECTS" is no figure of speech. Go into the vegetable garden: would you asparagus?—beetles; would you radish?—maggots; early cabbages and cauliflowers?—green worms and lice above ground, and club-root below. Would you cucumber?—the "flea" and striped-bug have something to say on that. If you like peas, you must also like *Bruchus pisi*. If you would—as all reasonable people should—make your pumpkin-pie out of squash, your chance for the delicious Marrow, Hubbard, or Marblehead is small, if you do not pick off that solemn and odorous bug, *Corvus tristis*, so as to leave the vines in good condition for the borer, which goes near the root of the matter, and the 6 or 8 feet of vigorous vine that your care has preserved, goes in a night. Tomatoes and egg-plants you grow to feed a fat fellow, as big as your finger, and so all through the catalogue, from the time the first asparagus-shoot comes through the ground, until the last parsnip is dug. Nor is it any better in the fruit garden. You have grown your strawberries in hills for two years, and now look for a grand crop; they were white with flowers, the fruit set finely, but you find that here and there a vine has collapsed; the next day more vines give out; you dig down, and find a fat, white grub, which likes what the strawberry produces below ground quite as well as you do that which it bears above. The majority of the strawberries may fail, but there are the currants, which set so full and are already ripening. Look at your early ripened currants, and they will be found to be still small, and have only turned red, because the borer has taken the life out of the stem. Rose-bugs will eat up the grape-blossoms, curculios sting the cherries and plums, and if there are any pears and apples this year, it will be because there were not enough of the codling-moth and its allies to go round. Take the ornamental parts of the grounds. Upon about one-half of the shrubs there will be some kind of an aphid to curl up and partly kill the leaves. You are fond of roses, and precious few do you get. You fight the early green fly with tobacco water; the later slug is dosed with whale-oil or carbolic soap, and when these are in a measure vanquished, and buds of promise come, you go out one morning, and find six or eight rose-bugs at every opening rose, and those which can not get a chance at the opening ones, are discounting the matter by gnawing the buds. If you believe any thing will trouble these fellows, just try it. As I do not expect to live anything like half a century longer, I can worry along, and take the few vegetables, fruits, and flowers, these winged scourges and their larvæ leave me, but my trouble is, as this destruction increases yearly, to guess what will be the state of affairs in years to come, unless something is done to arrest this devastation. Unless united action can be had, individual effort is useless. The Apaches, who make their raids upon the borders of northern Mexico, steal judiciously, a few horses here, and a few cattle there, but never break up the settlement, as that would be, so to speak, destroying the nest-egg. Our insects seem to have some such instinct, and they do not, as the grasshoppers of the West, make a clean sweep, but leave us just enough to encourage us to go on and provide food for their progeny of next year. One person can do nothing; my neighbor on one side says: "My man tells me

that the worms are eating up his cabbages." My neighbor on the other side says: "Well, I never *did* see anything like it." But neither do the first thing to kill the pest. What good does it do for me to dust, and powder, and squirt all the remedies I can hear of—and I do kill some—while on each side of me there is ample provision for next year's insects. If a State has a right to legislate against Canada thistles, have they not the same right to make laws to prevent the increase of the squash-bug, the rose-bug, the codling moth, or any other controllable insect, that now takes the larger share of our vegetables and fruits, to say nothing of our flowers. I did not intend to make so long a "preach" about insects, but I am well persuaded that it is the duty of every State to look to this matter, as one affecting its material interests, as much as vile weeds, stray animals, or horse-thieves. Missouri has set a grand example to the older States. She has as State Entomologist, a competent man, to tell the people which insects are injurious, and how they may be fought. I hope that after a proper time for this knowledge to be disseminated, she will set a still better example, and make it a penal offence for any one to harbor and allow to multiply any preventible insect.

This spring I have had a great show of

FLOWERING SHRUBS, and am more than ever convinced that not half enough attention has been given to these. The most of my shrubs have now been out for four years, and being well established, they flower with wonderful profusion. A good selection of shrubs can be had at 25 to 50 cents each, just about the price of some bedding plants, which last only a season, while shrubs are practically for a life time. If asked to name twelve of the best, I should be puzzled, as the number is not large enough to comprise all the really desirable things. If my list were twelve, six, or even three, I know three that I could not leave out: *Weigela Deboisiana*; *Deutzia crenata*, the double; and *Hydrangea paniculata grandiflora*. Of all the Weigelas, and I think I have them all, Debois' is by far the finest; it is so floriferous that each stem is a dense mass of dark rose-purple flowers, and neither stem nor leaf to be seen. A bush which stands up well above the fence, was, when in flower, a bright landmark, that could be seen a long way off. The double Deutzia is not so showy, but is one of those charming shrubs, that one is never tired of. Its flower-buds are purple-tinted, and the contrast of the unopened buds at the top of a cluster, with the pure white of the fully opened ones below, is very pleasing. As to the Great-flowered Panicle Hydrangea, I have praised that so often, that I am afraid it will be thought that I have plants to sell. As I have but one plant, and that the largest I have seen, and never sold a plant of any kind in my life, I may be allowed to say that if restricted to just one shrub, it would be this. It only comes in August when most shrubs have got through. As I write we are in the midst of the

STRAWBERRIES.—If any one wishes to know how many worthless strawberries there are, let him set out every kind he can get. I did so for my own instruction, but while this kind of planting is very edifying, it makes a poor show on the table. I at first thought that I would keep up a collection of all, good and bad, but needing the land for other purposes, and considering that Dr. Hexamer was keeping up a standard collection—many thanks be to him—this spring a large lot of my fancy sorts went

under. I thought we should be nearly without strawberries this year, as a bed for fruit, put out in another place, could yield nothing until another year; but much to my surprise, we have had all the berries we could eat. The main reliance had been upon four rows of Chas. Downing, each 35 feet long. A row of the Black Defiance—most excellent berry—has helped, but the rest, a dozen or more sorts, count for nothing. Two rows of Kentucky are coming on, to prolong the picking, and instead of scarcity, we have had abundance. If there is any better berry, upon light soil, for family use, than Charles Downing, I am desirous of knowing what it is. It is good to know that a name so highly esteemed, is in this case properly bestowed, and the fruit is a precious legacy, left us by that excellent man, the lamented J. S. Downer, of Kentucky. Upon my soil, varieties in high favor elsewhere, are quite useless. In this class, I am sorry to be obliged to place a berry that bears so high a name as President Wilder, but we can console him by saying that Napoleon III is no better. Kissena, a prize-berry of a few years ago, is on my bed as small, sour, and worthless, as a fruit can be; and so I might go on enumerating a long list of the kinds, that are not worth growing upon my light sandy soil, no matter how well they are fertilized.

Some New Varieties of Strawberries.

New varieties of Strawberries are not so numerous as they were a few years ago, yet each season brings out some novelties. There are several enthusiastic amateurs, who are quietly at work in the hope of producing a better berry than we yet have. Prominent among these is Mr. E. W. Durand, of Irvington, N. J., to whom we are indebted for Black Defiance, and some others. Mr. D. each year raises some thousands of seedlings, and also tests several thousands of previous years, and thus performs an amount of labor that few would be willing to undertake. Mr. Durand is very careful not to send out any seedlings, until they have been tested for several years. A few weeks ago he exhibited at our office a half dozen new varieties, either of which would have made a sensation a few years ago. One of these novelties in particular will doubtless be heard of hereafter. This berry, in size and quality combined, has probably not been equalled, and Mr. Durand gives an excellent account of the plant. The variety has not yet received a name, but fruit-growers will be glad to know that Mr. Durand still continues his labors, and that there are some fine results in store for them.

THE DUCHESS.—Last year Dr. Hexamer, of New Castle, Westchester Co., N. Y., sent us specimens of the fruit of this variety, which seemed to be of excellent quality and early. Our own plants being too small to allow of a fair judgment, we requested Dr. H. to state how the Duchess had done with him. He replies:

"It has for three years ripened earlier than any other of over one hundred kinds. Its berries are larger than those of other very early varieties, hold out well in size, and are of uniform globular shape, without neck; color, light crimson; flavor, good and sprightly, without being acid like the Wilson; texture, firm. Berries sent to Virginia, arrived there in good condition, three days after being picked. Foliage hardy and vigorous, withstanding the severe drouth of last year exceedingly well.

This variety has not yet been disseminated, but will, if it succeeds in other localities as well as in the vicinity of New York, form a most valuable addition to the list of early strawberries."

As Dr. H. has a soil quite different from ours, we requested he would state how some of the newer sorts have done with him, and he adds the following notes:

MONARCH OF THE WEST.—A large, irregular globular berry, of dark crimson color, fair flavor, and moderate firmness. On our soil, a light clay, it is not productive enough to be profitable.

CHAMPION.—Reports from many localities show that this variety is not excelled in size and productiveness. Its quality is rather indifferent, and it lacks the firmness necessary to withstand long carriage, but for local markets it will, no doubt, be much sought for. [Quite worthless on our light soil.—ED.]

BLACK DEFIANCE.—Continues to gain many friends. It seems well adapted for many varying localities and soils, and its large size, excellent flavor, and great productiveness, make it one of the most valuable varieties for the family garden.

DR. WARDER did not bring to the East its good qualities, which gained for it at the West the silver cup of the Cincinnati Hort. Society.

Our experience with these two last named varieties is the same as that of Dr. Hexamer.

Preserving Flowers—Winter Bouquets.

Those flowers known as "everlasting," of which the Helichrysums and Rhodanthes are examples, have petals of a papery texture, and when these are cut early and dried properly, they form pleasing winter bouquets. So grasses, both cultivated and wild, if dried in the shade and made up in a tasteful manner, form acceptable room decorations, as do dried ferns and skeletonized leaves. Within a few years baskets, bouquets, and floral designs, have been imported in considerable quantities, and though these are largely made up of everlasting flowers, yet they contain other flowers of their natural colors. So also large bunches and bouquets of grasses, dyed of all sorts of unnatural colors, even to black, are offered by the dealers. There is no subject upon which we have had more frequent inquiries, than upon the preservation of flowers, and especially the coloring and crystallizing of grasses. While some of these winter ornaments are pretty and tasteful enough, to our notion there is nothing more unnatural than grasses colored of all the hues in the rainbow, and some that are not there, or loaded down with alum crystals—but as many do like these things, we propose to tell them how they are done. Of course those who, in this country or abroad, make a business of preparing dried flowers, grasses, and the like, for the market, are disposed to keep the processes as secret as possible, and but little has heretofore been published about it. Within the past year there have been articles in the European journals, especially in the Garden, giving useful information; we were about to experiment upon the methods given in the foreign journals, when Mr. J. Peterson, of Chicago, Ill., sent us a manuscript upon the subject, which he wished us to publish in a book-form. As we did not think there was sufficient material to warrant making a book, we purchased the manu-

script of the author, to use in the *Agriculturist*, or in such manner as we chose. What we may publish upon these matters are with Mr. Peterson's articles as a basis, to which will be added such information as can be gathered from other sources, as well as the results of our own experiments. The two leading methods of treating flowers (excepting the so called everlasting), to dry them in their natural form and colors, is by the use of sulphurous acid, and by drying in sand. As the last named method is a very old one, and is likely to be more generally known than the other, we give the sulphur process first. When sulphur is burned, the well known suffocating fumes of sulphurous acid (SO_2) are produced; the bleaching properties of this are well known, it being used for whitening straw, and other materials; it also has the property of preventing the decay of vegetable substances, and it has been found that certain flowers, after they have been thoroughly exposed to the sulphur fumes, will dry and preserve their proper forms, and though the action of the sulphur destroys their colors, these will be after awhile for the most part regained. The apparatus required for this operation is very simple—a tight box, with an arrangement for suspending the flowers, and a vessel to hold a few coals upon which the sulphur is burned. Any box, if sufficiently large and tight, will answer. One about three feet each way is best for large operations, but one only two feet square will answer. If not tight, the box must be made so by pasting paper over every crack and opening, as the success of the operation depends upon confining the sulphur fumes as closely as possible. The whole top of the box may open, in which case it may be necessary to place a damp cloth

between the edges of the box and the lid, and weight the lid down with stones to make a close joint. Cleats are nailed to the inside of the box, an inch or two below the edge, upon which rest the ends of light sticks, upon which to hang the flowers. The flowers are tied together in bunches of two to four, according to their size; then each two bunches are tied together in such a manner that they can be hung upon the cross-sticks. Having prepared the flowers, and placed them on the sticks, they are ready for the sulphur. Any old iron vessel will answer for a fire-pan, or a flower-pot, with its hole plugged up, and half or more filled with ashes, will answer as well as anything. Put some live charcoal in the fire-pan, set it in the box, and drop upon it some lumps of roll-sulphur. An ounce, or a little more, is suf-

ficient. As soon as the sulphur is on fire, the box must be closed. If the box is perfectly tight, the oxygen of the air will be all consumed, and combustion checked, before a sufficient quantity of sulphur-fumes have been formed; to guard against this, an inch-hole is to be bored in the box near the bottom, and another in the top; these are to have corks fitted into them, by which they can be closed at will. After the box is shut, these holes are left open eight or ten minutes, by which time the box will be well filled, and the corks may be put in place. The box, thus closed, is allowed to stand for twenty-four hours. When opened, the flowers will be found to be bleached and white; they are then taken out, and hung up in a dry, shaded, well ventilated room. The flowers thus prepared are said to keep for any

We may state here, with reference to everlasting flowers, that they should be cut before they fully expand, and tied in bunches not large enough to crowd one another out of shape, and be hung, head downward, in an airy room to dry. The methods of coloring these will be given later.

The grasses can be dried as they come into perfection during the season, as they are always dried preparatory to coloring and crystallizing. Many of our native grasses are well worth looking after.

The Manihot Hibiscus.

There is found along the banks of the Mississippi, and other Southern localities, a fine

large flowered Hibiscus, which was at one time supposed to be a native, but is now regarded as an introduced plant, the *Hibiscus Manihot*. The plant is a native of the East Indies, and has long been cultivated in Europe as a greenhouse perennial. The stems are four feet or more high; the leaves five to seven-parted with long and narrow divisions, which are sometimes nearly a foot in length. The flower is similar in structure to that of the Hollyhock and others of the Mallow Family, and is six inches or more across; the petals are of a fine canary-yellow color, each with a dark brownish purple spot at the base, which forms a fine contrast with the yellow, and makes the flower quite showy. Like many other perennials, this will, if the seeds are sown early, bloom the first year, and it may be treated like an annual, or the roots may be taken up in the fall, and kept over winter in the cellar, if not wanted to bloom in the greenhouse. Of course it is hardy in the

warmer States. We had long known this plant from herbarium specimens, and were much pleased to receive last year some seeds from Peter Henderson & Co., from which we raised plants which flowered abundantly the same season. The engraving shows the flower and leaf, much reduced in size.

THE JAPANESE PRIMROSE.—Some of our florist friends think that in our article in June, we did not give the Japanese Primrose, *Primula Japonica*, all the credit to which it is entitled, while others have called to say that they were glad to see the article, as it was entirely just. We have nothing against the Primrose, but we have a strong objection to the European custom of over praising every new plant.



THE MANIHOT HIBISCUS.—(*Hibiscus Manihot*.)

length of time, provided the air is dry; hence in damp weather the room where they are hung must be closed. When the flowers are removed from the box, they resume their proper colors, some in a few hours, and others require several days. The treatment to make up flowers preserved by the sulphur-process, will be given at another time. The following flowers have been found suited to this process: China Asters; Larkspurs, especially the dark-blue ones; Fuchsias, the well-developed buds making better specimens than the open flowers; Roses, the double, well-filled sorts, except white; Goldenrods, all the yellow ones; Spiraeas, all the red flowering ones; the white *Xeranthemum annuum*, which, though an everlasting, does not dry pure white, unless treated with sulphur. This list will, no doubt, be considerably enlarged.

THE HOUSEHOLD.

(For other Household Items, see "Basket" pages).

Comfortable Country Chairs.

How rarely does one find really comfortable chairs anywhere? People seem to buy the style of furniture in fashion at the time, and this is usually made with a greater regard to show, than to comfort. In the country, where hard working men and women need easy and restful seats, there seems to be a great lack of them. The best room may have some hair-covered or rep-covered rocking or

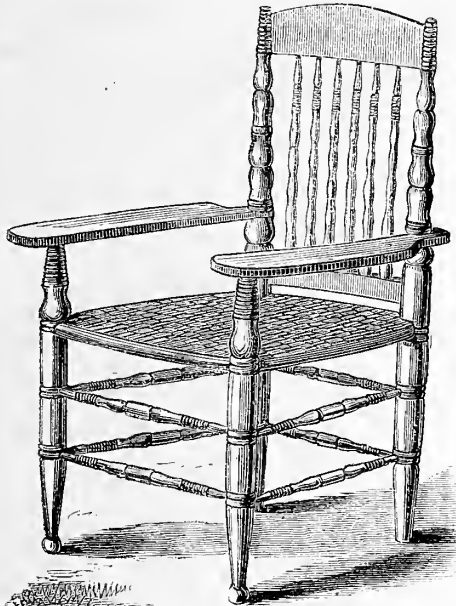

EASY-CHAIR.

lounging chairs, but these are too good for daily use, by tired people in their working clothes, and as for taking the best furniture out of doors, that is not to be thought of. We Americans, especially those of us who live in the country, make but very little use of our spacious summer parlor—"all out doors"—A wide spreading tree, a vine covered arbor, a broad veranda or porch, an awning like a huge umbrella, or a tent with no sides or even an open shed is a much more com-

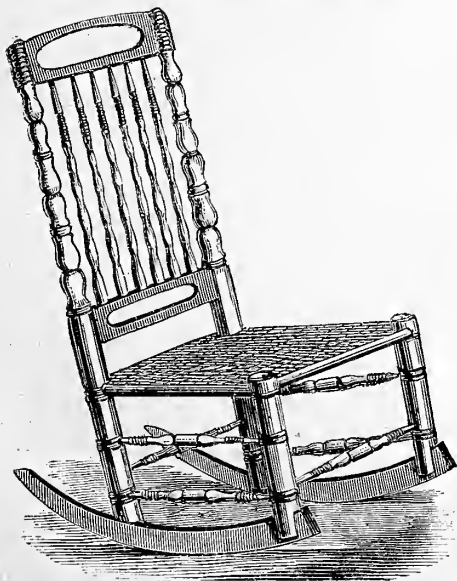

ROCKING-CHAIR.

fortable place for sewing, reading, and resting, than any place in-doors, and often comes handy for ironing and other work. For the enjoyment of the open air in any case, seats and chairs that are not too good for rough usage or too rough for ease are needed. The good old-fashioned framed chairs, with split-wood or flaggged seats, have long been

discarded for the glued work of the modern cabinet maker, but we are glad to see them coming into use again; they were formerly the regular furniture of the farm house; now they are offered as luxuries at the fashionable furnishing stores, and are purchased by those city persons who go into the country for the summer, and wish to take some strong comfortable chairs with them, as they are quite sure to find no such thing at a country hotel or farm boarding house. We give drawings of two of these, which will, no doubt, be new to young housekeepers, but there are, we are sure, many old ones who can remember when such chairs as these were good enough for the best. Within the half century there has been wonderful improvement in household conveniences, but it does not lie in the direction of furniture for daily use.

Some of the "rustic" furniture on sale is very pretty to look at, but one would find it anything but pleasant to sit in for long at a time.

pudding—Sponge Cake—Catsup.

The housekeepers of our circle are certainly very ready to assist one another; we do not know that we have asked for aid in any case, that the replies were not abundant and prompt. In June last, we published a request evidently from a young housekeeper, whose statement that she had tried "and failed to suit George" seemed to be so wifely, that her note was given just as she wrote it. The appeal has brought out so many replies, that we despair of ever publishing all. The one now given is from Mrs. "M. A. D." St. Paul, Minn., and we may print others; she says:

First, the lady wishes a nice, light, boiled pudding, that will please "George." My husband, who is not very fond of puddings in general, likes both of the following:

POOR MAN'S PUDDING.—One cup of syrup; and if desired, one or two spoonfuls of sugar; half cup of butter; one cup of sweet milk; one cup of raisins; one pt. of flour; one or two eggs; one tea-spoonful of cream-of-tartar; half tea-spoon of soda; a little salt. Put in a pudding dish and bake or steam. To be eaten with liquid sauce.

STET PUDDING.—One cup of suet; one cup of molasses; one cup of raisins; one cup of milk; three cups of flour, or one and a half cup of cornmeal, and one cup of flour; one tea-spoonful of soda. Stir molasses and milk together, put in soda, then suet, then flour slowly, then raisins. Steam three hours in pudding dish. Eat with sauce.

SPONGE CAKE.—The following recipe for sponge cake, I know to be excellent. Ten eggs; the same weight of sugar, and one half the weight of flour. The grated rind and juice of one lemon. Beat yolks and sugar to a cream; then stir in gradually and very gently the flour, and the whites of the eggs well beaten; add lemon. Watch while baking.

TOMATO CATSUP.—To one peck of ripe tomatoes, add one tea-cup of salt; three table-spoonfuls of black pepper; two do. cloves; two do. allspice; one large red pepper, fresh from the garden; four large onions, chopped fine; one tea-cup of brown sugar; one quart of good vinegar. Pour boiling water on the tomatoes to remove the skins, then cut up in pieces or mash in your fingers, add the above ingredients, and boil two hours in a large porcelain kettle. Add a tea-cup of celery seed, if liked, and then mash it through a common colander. Put on the fire again, and let it come to a boil, then bottle while hot, and seal the bottles, although it will keep a long while only corked, without being sealed. Dry all that will not pass through the colander for soup in the winter; but mash all through that will go, as it makes the catsup richer and thicker. The above catsup I know will keep a year, and I have no doubt, would keep two or three years, as mine is just as good now as it was when I put it up last summer, and many of the bottles were merely corked. I boiled it longer than two hours, making it very dark, and when put through the colander, so thick and almost jelly-like that it has to be shaken out of the bottles.

Home Topics.

BY FAITH ROCHESTER.

BERRYING.—Have you noticed the difference in children, with respect to their berry-picking ability? Some never have any "luck," you know; while other children, who go in the same party, bring home a fine lot of berries. I could not understand it when I was a child, but I am now able to explain the case to my little berry-pickers, and their "luck" is better than mine used to be.

Children should be taught to regard berry-picking as a business, while they are engaged in it, and nothing should divert them from it till the business is done. If they go into the woods and fields, a thousand beautiful and wonderful things may attract their attention, and I can not say that these wonderful things are of less importance to them than berries. One thing at a time, however.

Teach them that it is not best to wait until they find the berries "thick," before they begin to gather them. They should pick every good berry they find in their way, though there may not be more than a dozen on a bush, or even less. While the "lucky" berry-pickers are slowly, but surely filling up their baskets, the luckless ones go sauntering on, looking for some place where they can find the berries "as thick as spatters," stopping to gather winter-greens, or mosses, to put in their pails, because they begin to fancy that they can not find any berries, and they think they may as well carry home something. In the meantime, perhaps, they eat the straggling berries on the bushes they pass, thinking there are not enough to pay for putting them in the pail, and hoping to make it all up when they find the loaded bushes. A lesson here is very important, as it will apply to all the business of life.

If they have set out to pick berries, with a knowledge that the folks at home desire and need the fruit, their honor should hold them to the berry-gathering till the duty is done. In all these matters the conscience should be cultivated.

They ought to be taught, too, that it is *wrong* to eat between meals, that even a few berries taken when the stomach has the last meal only partially disposed of, or if taken when the stomach needs its regular rest, interferes with the health. If children begin to feed themselves when in the berry-field, it usually interferes seriously with the filling of their berry-baskets, and the best fruit is what they eat. They should set out with the determination not to eat a single berry till the regular eating time comes. I know that this can be done, for I have seen it. It is a good exercise in self-control, and all children could more easily accomplish it, if grown people were not so ignorant and so careless of all these laws of health in their own habits and consequent examples. Not long ago I saw one of the best of fathers, who had lately been sincerely rejoicing that his little children had learned not to eat between meals, come into their presence and eat an apple in the middle of the forenoon. It had not been easy for the mother to change her children's habits for the better, and they were evidently perplexed by their father's example, after all that had been said to them. This is one way of causing the "little ones to offend." This father had not learned to regard fruit as food.

What shall be done with the berries brought home? Could any but a heathen mother say to the children, who had conscientiously gathered the berries, "No, no! I want all of these berries for pies and for canning?" It is fair to give the children a generous share, and to give them while they are fresh. They will never be so delicious or so wholesome again. Ah! if the children could each have all they want of sweet new milk, with good bread and plenty of ripe berries in it! That is far better than sauce-dishes of heavily sugared berries.

Can all the berries you like, *after* you have supplied your family with fresh berries. It is not necessary to wait until the berry season is about over before canning, only do not rob the table of fresh berries in the berry season, in order to treat company with canned or preserved berries in the win-

ter. Fresh berries are very wholesome food, if eaten simply dressed, with nice sugar, or cream, or in milk, at the regular meals.

THAT FRYING-PAN.—And now the doctors are after us—us farmers' wives. The doctors of Massachusetts say, by way of the State Board of Health Report for 1874, that one of the most crying sins against hygiene in farmers' families is *too much frying of food*. Food which would be good and wholesome boiled or baked, is often made as indigestible by its contact and admixture with melted fat, or butter, as to be almost ruined for all purposes of nutrition. Those who take a good deal of out-door exercise, can stand this abuse of their stomachs much longer than others can, whose work is in the house, or who work chiefly with their brains. "The most indigestible of all kinds of food are fatty and oily substances, if heated. It is on this account that pie-crust and articles boiled or fried in fat, or butter, are deemed not as healthful as other food."

Really, I can not think of a single article of food that must be fried. I know of nothing which can not be made quite as palatable, or more so, when cooked by some other method. All kinds of meats are better broiled, or boiled, or baked, or roasted. It is so with every kind of fish that I know of. Vegetables of all kinds may be boiled, or baked, or steamed; and, certainly, the poorest way to deal with fruit is to fry it. [It may be new to some of our readers that apples, fried in pork fat, are quite a favorite dish with many.—Ed.] No kind of grain can be made up so nicely, or healthfully, by means of the frying-pan, as by use of the oven, or steamer.

To warm over cold potatoes, make them into potato balls, seasoned with cream, and brown them on a baking tin in the oven; or wash them with a fork or potato-masher with cream or milk and salt, in a spider, and warm them on the top of the stove.

If you have cold mush on hand, the easiest thing is to eat it cold, with milk or with cream. Or you can heat it thoroughly in the oven. Or you can make it into nice mush-balls—oat-meal, corn-meal, graham, rye—by mixing the mush stiff with white flour, and baking in balls. It is not necessary to fry cold food in order to warm it over; but if it seems most convenient or desirable, it may be heated upon a griddle, or even in a flat-bottomed frying-pan, with only enough butter to keep the food from sticking when it is laid cold upon the hot iron. This can hardly be called frying, and does not fill the room with the odor of scorched grease.

Aside from the unhealthfulness of fried food, we should banish the frying-pan, if possible, on account of the contamination from this source of the air of our rooms. [Of course we allow Mrs. Rochester to express her views on this matter, and we agree with her that it is better to abolish the frying-pan altogether, than to have so much good food spoiled. But there is proper and improper frying, and when certain things are properly fried, they are quite free from grease. Smelts, properly fried, may be served on a napkin without soiling it; the celebrated Saratoga fried potatoes are put up like bonbons without a hint of greasing the paper, and a veal cutlet, or lamb chop, properly covered with eggs and crumbs, may be fried in an unobjectionable manner. The trouble is that many sizzle things in fat, and think they are fried.—Ed.]

SMALL WAISTS.—We are all finding out, gradually, that deformity and beauty never coincide. As we learn more about nature and her laws, our childish self-conceit in respect to our superior taste, gives way before a growing admiration of the beauty of use and fitness in all that God has made. Who that knows how wonderfully the heart and lungs perform their work—yes, and the stomach and liver too!—when these organs have the necessary room and building materials, can even look upon a wasp-shaped female figure without horror. I can not possibly admire such evidence of a slow murder taking place before my eyes. I can not help thinking of the cramped organs, and of the blood which can not speed upon its life-giving errands through a body so pinched and pressed, blood which has

little life to give, so badly is it fed by food which never is well digested in a stomach cramped for room, and so poorly is it supplied with oxygen in the oppressed, poorly-working lungs.

Do study physiology, my silly friend, and pray to the Lord to convert you to some religion, which will make you mindful of His laws written upon His works, and reverent in your treatment of the "living temple" for His spirit, which is the human form.

You think I do not mean you? I do mean you! I mean, at least, nine women out of every ten. For, though tight-lacing is said to be out of fashion, I am convinced that very few women wear their clothing loose enough about the waist. Sometimes it is only the belt that is drawn too tight, but that can never be done with impunity.

"But my girls have naturally small waists," says a fond mamma, whose ignorance leads her to admire the round, tapering waists of her daughters. I have heard often of "naturally small" waists, even from girls who were in torture while they spoke. Nature never makes such waists. The pinching may have begun so early—even in babyhood—that no one has ever seen any particular change. The bands were pinned so tight that the floating ribs have never had a fair chance to spread as the body grew, and the young girl, liking the smooth fit of her dresses as she grew older, has always worn her garments snugly fitting, though she may not have worn corsets at all. These are your "naturally small waists"; and these are your girls who die early of consumption, or live lives of debility and dependence upon a doctor's care.

It is so very uncommon to find a woman who will confess that her corset is drawn too tight, that many believe no such person exists. There are girls, however, who acknowledge that their clothing is tight; but they "like to feel it snug." They can't bear to feel as though they are "all dropping to pieces," as they say. They have learned to depend upon the support given by the bones and springs of the corset, and their own muscles have little strength and elasticity. It sometimes happens that a woman who asserts that her corsets are not worn tight, has to go without that part of her clothing for a little time, while mending or cleaning the corset. Then, if she undertakes any very active exercise with her arms, you are almost sure to see her dress-waist bursting at the seams or hooks, or button-holes—proof positive that the corset was tight.

BREAD CRACKERS.—I have asked "grandma" to tell me just how she makes the nice little bread crackers, which my children and their mother like so much. She says she has no particular recipe for them, but as near as she can tell they are made as follows: Take about a quart of the light bread dough, when you make it into loaves (it having been previously kneaded and allowed to rise again), work into this a piece of butter about the size of a butternut, or a small hen's egg, in the same way that you would work butter into bread dough to make biscuit. Roll the dough to the thickness of about three-quarters of an inch, or less than an inch in thickness. Cut it into shapes with a small biscuit cutter (or empty spec-box!). Let these biscuits rise till very light, but never until they begin to sour, and then put them in your hot oven, and bake them. When they have partially cooled, break them apart (or separate them from each other), stand them upon their edges in a baking tin, and set them back in the warm oven, or in a tin warming-closet, to dry thoroughly.

These are better for the children than bread and butter, though not suitable alone for a whole meal. They are nice to eat with juicy fruits, or with soups, and are good in milk. They are more wholesome than the sale crackers, which have more or less lard in their composition, whatever be their name or shape.

APPLE PIES FOR LUNCHES.—Try this. I have tried it with success, and I have found no hungry person who did not praise the little pies. You can see for yourself when you read the recipe, that they can not come under the censure which intelligent people bestow upon ordinary pie. They seem

ridiculously simple, but if well mixed and thoroughly baked, they are delicious. Take good juicy dried apple-sauce—but first about the cooking of that sauce. Either soak the dried apples over night, and then cook them slowly in the same water next morning, or let them heat up slowly upon the back of the stove, with plenty of water to soak them out fully, and keep them from burning while cooking, and add the necessary sugar while the fruit is still boiling. Let the sauce be thoroughly soft, or well done. Then stir into a pint, or any quantity of it, enough graham flour to make a rather stiff batter. Dip a spoonful of this into dry graham flour, and, taking it into your floury hands, mold it into a round flattish biscuit. Fill your baking tins with these, and put them into a hot oven. Bake them thoroughly—upon the clean oven grate, if you prefer it to the tins. The process of molding the pies suggests the proper stiffness of the dough, but do not get it too stiff—that would make the pies (or apple-cakes?) too hard.

Any other sauce can be used in the same way—fresh apples stewed, stewed peaches, stewed prunes, huckleberries,—anything that is simple and juicy. Let the baking be done in a hot oven, and thoroughly done without burning. Let the children have these to carry to school for the noon lunch. The graham flour gives the proper nourishment for their bodies, and the apple makes it more palatable, and is in the most convenient shape for their use, unless they can have raw apples and graham crackers.

A Mother on Bathing

BY MRS. J. C. B.

It seems strange and unaccountable that so many of the really intelligent class act as if in ignorance of the necessity and benefit of bathing. It seems almost incredible, but there are many ladies most particular as to dress and fashion, who almost wholly neglect this matter. Some mothers think when their children get beyond two or three years of age, the frequent entire bath can be dispensed with. If some of the main facts of physiology were well known and understood, every one would perceive that cleanliness of the skin, is one of the conditions of good health.

We learn that the skin has innumerable minute perspiration tubes, opening upon the cuticle, and these openings are called pores. These tubes are hollow, like a pipe-stem, lined with wonderfully minute capillaries, which are constantly exhaling the noxious and decayed particles of the body, just as the lungs pour them out through the mouth and nose. It seems clear that injury, more or less, must ensue if this drainage from the body becomes obstructed. It happens when bathing is disregarded, that the lungs, kidneys or bowels, have more than their own apportionment of work. If these are strong and healthy, they may bear the tax with little apparent injury, but in most cases a lowering of the vitality and tone of the system ensues.

Large bath-tubs are pleasant and convenient, but not indispensable to the proper cleansing of the skin. A speedy sponging of the body in pure water, followed by friction in pure air is all that is necessary. When disinclined to use water, I find a thorough application of the flesh-brush to the whole person, an admirable substitute; especially on retiring, it relieves nervousness, equalizes the circulation, and induces quiet sleep. Mothers, above all, should see that their children are well bathed. If their skins are kept active and healthy, there will not be half the danger, from fever, colds, and eruptive diseases. If your little one is cross or troublesome, and finds no occupation that pleases him, try the effect of a bath, sometimes it is magical, and if tired, he will go to sleep and awaken bright, cheerful, and happy.

Do not though, as I have seen some parents do, plunge a child into cold water when he screams and shrinks from it, thinking you are doing a good deed. Nature must be the guide, if your child has a nervous constitution, a shock of this kind is only exhausting and injurious.

BOYS & GIRLS' COLUMNS.

A Pigeon-House for Boys.

Boys who wish to keep pigeons where there is no barn or other building in the loft of which they can make a pigeon-house, often put up boxes and coops in the yard and along the fences. These are generally unsightly, and are moreover exposed to the attacks of cats, which are fond of fat squabs. A friend who had to put up an independent pigeon-house sends us drawings of it. This house stands upon a very firm post, which should be high enough to place it out of the reach of meddlers. The manner in which it is arranged will be understood from the drawings and his description, which is as follows:

A pigeon house that may be made safe from the depredations of cats, or owls, and all other enemies, is shown in figure 1. It is elevated upon a post set firmly in the ground, and not less than 10 feet high. Cross-bars are fastened to the post, as shown at fig. 2, for the frame of the house. The frame is made of light half-inch clap-boards. The bottom is boarded in, and the nest-boxes are placed upon it. In the figure the alighting-board is seen at *a*, the nests at *b*, and that portion of the bottom,

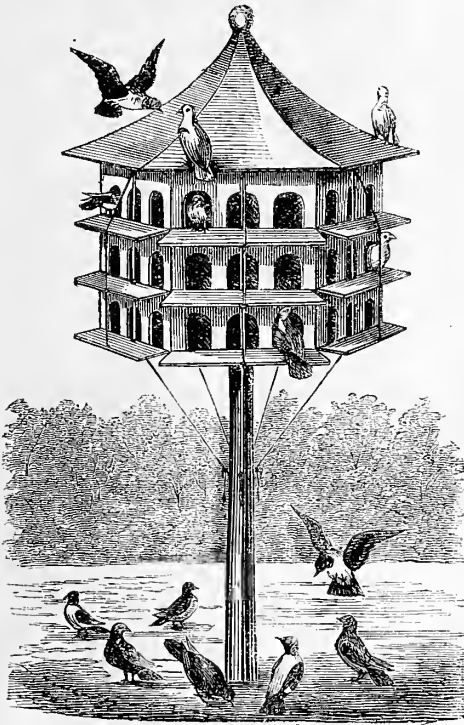

Fig. 1.—ELEVATED PIGEON-HOUSE.

at *c*, is fastened with hinges, or strips of leather, so that the separate pieces will fall down, when not held in place by buttons. Above the nests a sloping roof is made, and above that, on a level with the upper row of holes, the upper cross-bars of the frame, of which three form the roosts. The droppings fall upon the sloping roof of the nests, and slide into the central part, and gather upon the bottom boards, *c, c*. These are cleared by turning the button which holds them, when they drop down and discharge themselves of the manure. This is very valuable, and should be preserved for use. The size of the house may be 6 feet wide and 4½ feet high, from the floor to the eaves. Each of the three cross-bars is thus 6 feet long, and each face of the house is three feet wide. There are three nests in each face, or eighteen in all, but this number may be

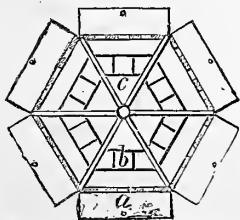

Fig. 2. SECTION OF HOUSE.

doubled by making two tiers of nests. The alighting-boards are raised up by cords, which pass over pulleys at the eaves, and may thus be closed at night to keep out owls. The post should be planted firmly enough to permit a ladder to be rested against the house, to enable the nests to be cleaned out occasionally.

A Child's Pun.—Do you know what a pun is? It is rather difficult to describe, but perhaps the shortest way is to say that it is a play upon words, in which a word with the same sound is used in place of another of a different meaning. Thus, when the young lady said to Douglas Jerrold, "I am very sad, you see,"

and he replied, "No, you are very fair, I see," he not only made a pun himself on *Pharisee*, but turned her remark into one on *Sadducee*. This is a very complete pun. We heard the other day of nearly as good a pun from a little girl. She said to her mother, "I wish my doll was realized." "What do you mean, my child?" asked the astonished mother. "She's got glass eyes now, and I wish her to have real eyes." That little thing made a better pun than some do who try to be funny.

Aunt Sue's Chats.

Mrs. S. G. M. thanks me for furnishing the children with so much amusement, but she has to "help them" with the puzzles, etc., etc., and adds, "they are restless children, and sometimes when I am busy sewing, I don't know how to keep them quiet."

Under such circumstances I have amused children for a long time with the rhyming game. I will illustrate it, although, I dare say, it is familiar to many of you.

I.—Jimmy, I have a bright thought, and it rhymes with "lip."

Jim.—Is it what you do from a cup?

I.—'Tis not to "sip."

Mary.—Is it what you do on the ice?

I.—'Tis not to "slip."

Jim.—Is it what you do with the scissors?

I.—'Tis not to "rip."

Jim.—Oh! Aunt Sue missed it; I didn't mean "rip."

I.—'Tis not to "snip."

Mary.—Is it what little lambs do?

I.—It is to "skip." Now it's Mary's turn, as she guessed it.

Then Mary has a "bright thought," which rhymes with "sky." After trying fly, shy, ery, my, pie, sly, rye, etc., Jimmy says, "Is it what a pig lives in?" "Yes, it's a sty."

This, you see, sets both parties guessing, and is a pretty good amusement for a rainy day. Try it, Mrs. M., and let me know how it works.

NELLIE A. W. says, she has read lately that there never was such a person as William Tell, and the story about shooting the apple from his son's head is all a fable. Nellie feels sorry to have to give up her hero. Well Nellie, *don't* give him up: his story is often told in very old German songs, and two chapels were erected centuries ago in memory of his exploits. If they believed in him, I don't know what right any one in the nineteenth century has to doubt his existence. I always liked Tell, but I consider the lad the "hero."

MINNIE F. G.—Yes indeed, Barnum's Hippodrome is well "worth seeing;" another month I may "tell" you "all about it."

CHARLEY EAMES.—Gold-fish were originally natives of China; silver-fish, though somewhat different in color, are the same species. They were introduced into France in the time of Madame Pompadour, some of them being sent to her for a present. In Portugal they are so abundant, that they are fried and eaten quite commonly. I don't know who imported them to Brooklyn, but the boys catch them here in the ponds. Do not fill your globe more than three-fourths full of water; do not place it in the sun, nor near the fire. Change the water every day. Some never give the fish any food, thinking that they get enough nutriment from the animalculæ contained in the water, while others feed them occasionally with little pellets of bread. A niece of mine had half a dozen gold-fish in a globe, which she tended very assiduously, occasionally dropping a bread-crumm into the globe, or a fly, and—it may be as a consequence—the fish died one by one, until only one little fish was left. Then said Lottie to me: "Auntie, this fish looks lonesome, shan't I take it over to Mrs. Prince's, and put it into her aquarium?" "Yes, dear, suppose you do." She did; and when she returned, I asked her, if the other fish gave him a hospitable reception. "Oh! very," she replied, they took him in, and did for him; one big fellow opened his mouth, and swallowed my little fish whole." "Why, Lottie!" "He did, Auntie! I was sorry for my poor little fellow, but I couldn't help laughing to see him so thoroughly taken in."

Moral.—Better be lonely than swallowed.

M. L. E.—I don't know much about the stings of bees, but if I should be stung by one out in the field or garden, I should immediately pull out the sting, if the insect had left it in my keeping, and apply a little poultice of mud. A few days ago I placed my hand on a wooden railing, but thinking I had set my finger on a red-hot needle, I took it up a great deal quicker than I had put it down, and, lo! there was a hornet walking sulkily away. Then I knew I had been stung, and went down stairs to bewail my fate among my friends, (it is so disagreeable to not have plenty of people about to witness one's sufferings!) One good Samaritan immediately went for some cooking soda, put a little of it on a strip of rag, moistened it, and applied it to my injured digit; it relieved the pain immediately. Alkalies, such as Soda or Ammonia (Hart-

shorn), if quickly applied, appear to have the power to neutralize the poison of these stings.

Now I must express my thanks for puzzles, letters, etc., to Giles F., P. A. McI., Tot, Mary J., H. Beuson, Miles S. W., and Jerry.

What Six Pecks of Potatoes Did.

It is not every farmer who reads an agricultural paper at all, fewer still read more than one, and it is very rare, indeed, that one of our farmers wishes to know what his brethren in other countries are doing. Some time ago a farmer in Pennsylvania wrote us to know about the best paper in England, as he thought he could learn something useful from it; at the same time he gave a brief story of his life, which he did not intend for publication, but thinking it would be of interest to farmers' boys, we asked permission to publish it. He replied: "You are at perfect liberty to use my letter as you see fit; if it encourages but one boy, it will be so much good accomplished." So we let him tell his own story:

"When I was a boy of about fourteen, the hogs broke into our garden when the ground was wet, and rooted up one corner to such an extent, that the soil, being naturally clayey, baked as hard as a brick-bat. The next spring, when my father came to spade the garden, he found this clay corner so hard and full of clods, that he abandoned it, and told me I might take it and do with it as I pleased. As I had often longed for a plot of ground of my own, I jumped at the chance. I set to work at once with a grubbing hoe (for it was too hard to spade), and brought it to as fine a condition as I could. Then I applied some manure and ashes, and planted it with potatoes. The plot was a small one, not more than about 6x12 feet, but I raised a bushel and a half of potatoes, which I sold for fifty cents per bushel, making 75 cents. This sum, with five cents obtained in some other way, was paid to a neighbor, who was raising a club for the *American Agriculturist*; the subscription was \$1 a year, and 80 cents in clubs of ten at that time, when the paper was much smaller than at present. I had a great thirst for agricultural knowledge, and have yet. I have taken the paper ever since, subscribing last New Year's for the eleventh time. The money for the paper was obtained the first three years from the plot of ground above alluded to, which, by the teachings of the paper, I brought to a very high state of cultivation. I afterwards got to farming my father's farm on shares, and this I followed up, until in my twenty-fourth year I married, and afterwards bought the farm. I think the paper has been getting better every year since. I commenced to take it so young, and have taken it so long, that I have learned to love it and its editors. I am putting its teachings into practice as fast as my means will admit. They enabled us last summer to get forty cents per pound for all the butter we made, while the general market price was, through June and July, but fifteen cents, but ours was good butter, and no mistake."

As the rest of the letter is about his plan for improving his stock, it will hardly interest boys. Now let every boy, who thinks there is no chance for him to ever be anything on the farm, but he must go off to the cities, which he mistakenly thinks are full of opportunities, just read this story of Miles Wall and take courage. He began with six pecks of potatoes, and a determination not only to be a farmer, but a good farmer. He found out how good farmers managed by reading the papers, and now by using his brains as well as his hands, he is in a position to talk about improved cattle and other improvements. We thank him on behalf of the boys for telling them this lesson.

Aunt Sue's Puzzle-Box.

ALPHABETICAL ARITHMETIC.

U B Y F T O R I Y (Y E R R F Y M

B R R I

B O E I

B R E Y

B O E I

M M

SQUARE WORDS.

- 1.—1. A house. 2. Place of contest. 3. At no time.
- 4. Active. 5. Soon.

- 2.—1. Smallest. 2. Older. 3. Farewell. 4. Appears.
- 5. Confidence.

THE LITTLE FOLKS.

TRANSPOSITIONS.

1. Transpose a heavenly messenger, and leave a place where two points meet; again, to collect things thinly scattered.

2. Transpose a descendent of the fallen angels, and leave the support of an arch; again, meaning fully mature.

3. Transpose a fiery heavenly body, and leave far off.

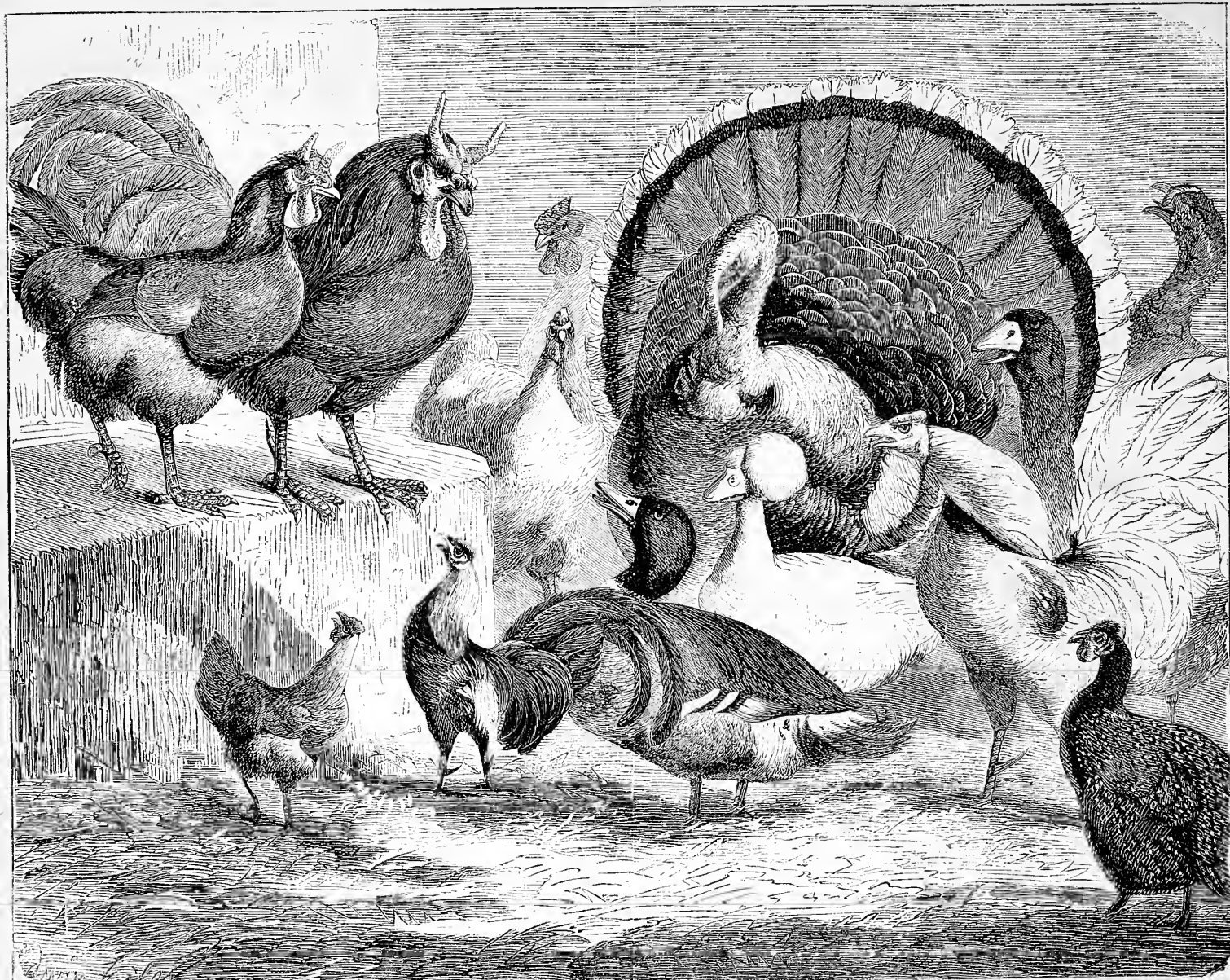

THE NEW COMERS IN THE POULTRY-YARD. — Drawn and Engraved for the American Agriculturist.

- 4. A country in Palestine, and leave a cupola; again, the prevailing fashion.
- 5. Transpose to gaze earnestly, into weeds; again, to prices paid; again, to drops of moisture.
- 6. Transpose a luminous heavenly body into animals; again, into sailors; again, into the plural of cunning dexterity.

M. P.

CHANGED HEADS.

Should we the whole world travel o'er,
From China's wall to England's shore,
Among them all no place we'd find,
To equal this that's in my mind.

Cut off my head, and in its place,
Another plainly shows its face;
Raising me high on stately walls,
Within whose sides lie sacred halls.

Another change—cut off my head
Again, and in its stead
A caput strange securely hold:
A foreign city I unfold.

HENRY.

CROSS-WORD.

My first is in rafter but not in beam,
My next is in slumber but not in dream,
My third is in flower but not in pink,
My fourth is in paper but not in ink,
My fifth is in wisdom but not in sense,
My sixth is in dollar but not in pence,
My seventh is in dahlia but not in rose,
My whole is a place where the orange-tree grows.

ANAGRAMS.

- 1. O buru dim.
- 2. Hurt a leg.
- 3. Clam dies.
- 4. Sappy dies.
- 5. So let him be.
- 6. Sand places.
- 7. Man near lot.
- 8. Race in, Bill.
- 9. Upset crops.
- 10. Seem molded.

DOUBLE ACROSTIC.

The initials and finals form two cities.

- 1. A fish. 2. A river. 3. Back. 4. Hindmost. 5. Royal. 6. A kind of bean. 7. A bird. 8. A boy's name.

NIP.

POSITIVES AND COMPARATIVES.

(Example: *Man, manner.*)

- 1. A kind of fog—a title.
- 2. Something much used in the kitchen—in the church.
- 3. Something made by the cook—what it is sometimes eaten out of.
- 4. A toy—a coin.
- 5. An article of wearing apparel—certain.
- 6. Part of a vessel—the captain.

A. AND B.

ANSWERS TO PUZZLES IN THE JUNE NUMBER.

HIDDEN NAMES OF ANCIENT GRECIAN DEITIES.—1. Thea. 2. Ceto. 3. Iris. 4. Sol. 5. Pan. 6. Ops.
PUZZLE.—Samuel.

NUMERICAL ENIGMAS.—1. Wisdom, justice, and moderation, (motto of Georgia). 2. A rolling stone gathers no moss.

SQUARE-WORDS.—

C O R D	D I S H
O D O R	I D E A
R O S A	S E A L
D R A Y	H A L T

PI.—Constant dropping will wear away stones.

CONOEALD SQUARE WORD.—H A S H

A S I A
S I T S
H A S H

TRANSPOSITIONS.—1. Master, stream. 2. Steam, mates. 3. Veto, vote. 4. Rogue, rouge. 5. Lucre, cruel. 6. Tasted, stated. 7. Wives, views.

ALPHABETICAL ARITHMETIC.—

395701)8439609290(21274 (Key: Hypocrites.)

Cross-Word.—Florence.

The New Comers.

When new scholars enter a school, the first day is a very awkward one for them, as the old scholars often behave in a very rude manner. The new comers feel ill enough at ease, from being in a strange place, and it hardly makes them feel more comfortable, to have all the old scholars stare at them and exchange looks, if not whispers, that evidently concern them. In the picture the new comers evidently feel in a quite different mood from the new scholars, and they show no signs whatever of being bashful, or of being annoyed at the staring. The strangers are some newly imported French fowls, which are distinguished by a very curious comb, this, instead of being like that of common fowls, is in two parts, which stand up, one upon each side of the head, like two horns, and presents such an odd appearance, that we do not wonder that the rest of the inhabitants in the barn-yard stare at the strangers. The old gobbler evidently does not mean to be astonished by any new fashions, but spreads his tail, swells up his wattles, and gets very red in the face; the other birds are not to be behind, and one and all put on their best looks: nor are the new comers afraid to be looked at, they stand out in full view, and look back again with a hearty good stare. We suppose this is the way these birds have of making an acquaintance, they do not have any one to formally introduce them, but they stare at one another until all hands are tired. It may be that the old rooster, who has been at the head of the barn-yard for a long time, will not be satisfied until he has a tussel with the new comer, to see who shall be master, but after a few days they will all get along without any trouble, and peck away at their corn in the quietest manner

Life Insurance.

It is good policy to have a good policy. To assure oneself that the assurance effected is effective, and will eventually be a pillar of strength and comfort to those in whose favor it is originated, is very nearly, if not quite, all the modern duty of men. And yet many a man jogs along through life vainly dreaming that it will last forever—forever being an indefinite idea of robust health. His glass shall discover to him the approaching wrinkle, and the inevitable thread of silver among the well-oiled curls. But with the vanity of self-appreciation, he flies to the cosmological mysteries to hide the advances of time; the inexorable apathy will overcome him, and he shall neither have policy nor prudence. "By-and-by," says he, "I will insure." By-and-by comes, and the sum which would otherwise have secured his family a competency, has been spent in the adornment of his favorite moustache, and the quiet little suppers after the theatres. In the course of the year, this will come to a total, double and treble his premium, and the physicians shall absorb the rest. "By-and-by" has made him uninsurable. "To-morrow," and "to-morrow" arrives, until there is no to-morrow, and the greatest inconvenience of all arrives, the inconvenience which settles all claims, policies and premiums, proving there are people who think less of their lives than other men do of their property.

We can pull down barns and build greater; the household gods can be replaced again and again; nothing that is of the earth or the waters under the earth but what can be fished up if lost. But life we can neither build nor make; we can pull it down, annihilate it, or gradually dissipate it; but to replace it is beyond the power of man. The sting of non-existence, while existing, is robbed of half its misery; the mind relieved of a dull, heavy weight, a man lives longer and easier, when his life is assured. This is the best policy of assurance to assure.

The United States Life Insurance Company of this city secures its policies by an exceptional integrity and carefulness of management; by its quarter-of-a-century record without blemish; by its vast accumulations; its moderate expenditures and its wholesome growth. Insure in it.

WIND-UP WATCH And Not Wear Out.
For sale by Watchmakers. By mail, 50 cents.
J. S. BIRCH, 87 Maiden Lane, New York.

GEO. A. PRINCE & CO.

ORGANS & MELODEONS.

The Oldest, Largest and Most Perfect Manufactory in the United States.

53,000

Now in use.

No other Musical Instrument ever obtained the same popularity.

Send for Price-Lists. Address **BUFFALO, N. Y.**

IT IS NOT ECONOMY

To buy a poor Shoe. Try Good

Cable Screw Wire FOR ECONOMY.

SOMETHING NEW in relation to Boys' Loading School. 8th year. No extras. All books furnished free to scholars. Catalogues free. Address **HIRSHAM H. POST, Prin., Sing Sing, N. Y.**

\$600 A MONTH made honestly with Stencil and Key-Check outfits. Catalogue and samples free. **S. M. SPENCER, 117 Hanover St., Boston, Mass.**

The Agricultural College of Cornell University.

This Institution is now fully organized with the following Professors and Instructors:

- J. P. Roberts, Practical and Experimental Agriculture.**
- John Stanton Gould, Lecturer on Mechanics applied to Agriculture.**
- A. N. Prentiss, Botany and Horticulture.**
- James Law, Veterinary Science and Practice.**
- G. C. Caldwell, Agricultural Chemistry.**
- J. H. Comstock, Agricultural Entomology.**
- C. Fred. Hart, General and Agricultural Geology.**
- E. H. Fuertes, Surveying.**
- C. Babcock, Architecture.**
- J. L. Morris, Mechanical Engineering.**
- J. E. Sweet, Practical Mechanic and Superintendent of Machine Shops.**
- E. C. Cleaves, Free-Hand Drawing and Mechanical Draughting.**

Besides these, other University Professors give full instruction in this Department in Mathematics, Modern Languages, Natural Philosophy, Human Physiology, History, and Political Economy.

The University Farm is now in condition to give useful illustration both as to processes and experiments. The University Library and Laboratories, and extensive illustrative collections of machinery, implements, models, apparatus, drawings, and specimens, are freely opened to students.

By a recent resolution of the Board of Trustees, all students in the Department of Agriculture are to be caucated **Free of any Charge for Tuition.**

And ample opportunity will be afforded to such students to pay for their room-rent in the University building by labor on the Farm, if they desire to do so.

The next entrance examinations will begin Sept. 8th. For Catalogue, giving full particulars, apply to **Prof. G. C. CALDWELL, Secretary of the Faculty.**

Asbestos Materials.

ASBESTOS ROOFING, PAINTS, CEMENTS, ROOF COATING, SHEATING, &c.

H. W. JOHNS, 87 MAIDEN LANE, N. Y., Established 1838. Patentee and Sole Manufacturer.

(CIRCULAR.)

Consumers' Importing Tea Co.,
No. 8 Church Street,
P. O. Box 5,509. New York City.

This is a combination of capitalists to supply the consumers of Teas throughout the United States on the mutual principle.

We have experienced agents in all the best districts of China and Japan to select Teas especially for our trade.

We expect every consumer of Teas to render us all the assistance they can in carrying out our enterprise, as we make a specialty of **SUPPLYING CONSUMERS ONLY** (and allow no middlemen to make any profit on our importations), which will enable us to supply them with Teas at prices lower than have ever been known, and of those fine qualities that seldom reach the interior, being sold only in the large cities and among the very wealthy.

Hoping the consumer will take an interest in our enterprise, and send at once for a circular with full explanations of how to proceed to obtain our goods, we remain,

Most respectfully yours,

Consumers' Importing Tea Co.,
No. 8 Church Street,
P. O. Box 5,509. New York City.

Entered, according to Act of Congress, in January, 1874, by the Consumers' Importing Tea Co., in the Office of the Librarian of Congress, Washington, D. C.

New York College of Veterinary Surgeons,
INCORPORATED 1857.

Lectures for 1874 will commence about the middle of October and continue until the last of February, 1875.
Fees: Matriculation, \$5; Faculty, \$120; Graduation, \$25; Dissecting, \$5; Address for Circulars,
A. F. LAUTARD, V.S., M.D., Sec'y.
205 Lexington Ave., New York.

Tongue-Lolling Bits.

We make Bits to prevent the above bad habit. \$2, \$3, or \$4, for cash with order, or C. O. D. Hand-forged Bits made in any style to order. Patentees of the **BALDWIN BIT**, for slide pullers and hard mouths. \$2, \$3, and \$4. Also agents for the **MARTIN BIT**. See adv. in "Trnf, Field, and Farm," and "Wilkes' Spirit of the Times."
JOS. BALDWIN & CO., Newark, N. J.

W. A. COVERT & CO., Produce Commission Merchants, 261 & 263 Pearl Street, New York. "Quick sales and prompt returns." Send for our weekly Prices-current and Marking Plate.

DIEHL WHEAT FOR SEED.
New crop now ready. Orders promptly filled.
JOSEPH HARRIS, Moreton Farm, Rochester, N. Y.

To Nurserymen,

TREE DEALERS AND PLANTERS.

Our Wholesale Catalogue for Autumn 1874, now ready, and sent FREE to all applicants.

Aug. 1, 1874.

EILWANGER & BARRY,
Mt. Hope Nurseries, ROCHESTER, N. Y.

HOME INSURANCE COMPANY OF NEW YORK,

OFFICE, 135 BROADWAY.

CASH CAPITAL, - - - - - \$2,500,000 00

Reserve for Re-insurance, July 1, 1874, - - - - - 1,919,971 53

Reserve for Unpaid Losses and Dividends, - - - - - 243,238 83

Net Surplus, - - - - - 549,171 04

TOTAL ASSETS, - - - - - \$5,212,381 40

A DIVIDEND OF FIVE PER CENT HAS BEEN DECLARED, PAYABLE ON AND AFTER THE 17th DAY OF JULY.

CHARLES J. MARTIN, President.
J. H. WASHBURN, Secretary.



Rifles, Shot Guns, Revolvers, Pistols, Ammunition, Fishing Tackle, etc. For Price-list, see page 137, April No. *Am. Agriculturist*, or address, with stamp,

GREAT WESTERN GUN WORKS,
285 Liberty St., Pittsburgh, Pa.

THE PEOPLE'S Force Pumps.

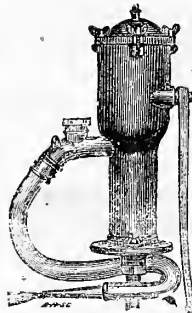

Awarded medal of American Institute over all competitors last fall. For the house and out of doors. Non-freezing and adaptable to wells from 6 to 100 feet deep. Highly recommended for city houses on account of their great power. Parties about to supply themselves are invited to call and examine. Circulars sent on application. Plumbers are particularly requested to call. See "Notes from the Pines," on page 182, May number, of *American Agriculturist*.

W. S. BLUNT,
77 Beekman Street, New York.

Geneva Nursery. Established 1846.

400 Acres of Fruit and Ornamental Trees. **LARGE STOCK OF**

Pear Trees—extra size, Standard and Dwarf.
Pear Trees—first class, five to seven feet.
Apple Trees—first class, Standard and Dwarf.
Cherry Trees—Feach, Plum, Orange, Quince.
Grape Vines—New varieties and old approved sorts.
Large Stock of Tree Roses, grown by us especially for the Trade. Fine forced hybrids. Our Trees and Plants are grown on heavy clay soil, which makes them very hardy. All at lowest prices. Catalogues free.
W. & T. SMITH, Geneva, N. Y.

A SILVER TIP

Adds Five Cents

TO THE COST OF A SHOE, and \$1 to its value.

TO SOUTHERN NURSERYMEN!

Our long experience in supplying the wants of Southern Nurserymen, enables us to offer for this fall a stock of trees unsurpassed for the Southern market. Standard and Dwarf Pears, Apples, Cherries, Plums, &c., in almost endless quantity. Send for Price List.
NICHOLAS & NEWSON, Geneva, N. Y.

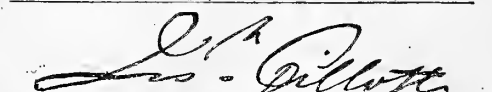

STEEL PENS!

Sold by all Dealers.

No. 91 JOHN ST., NEW YORK.
HENRY HOE, Sole Agent, JOSEPH GILLOTT & SONS.

VEGETABLE SEEDS,

FOR SOWING IN AUGUST AND SEPTEMBER.

Table listing vegetable seeds with columns for 'Per oz.', 'Per lb.', and seed names like 'RADISH, New California White Winter', 'Lettuce, Boston Market extra fine', etc.

FLORAL SEEDS FOR FALL SOWING.—20 varieties Hardy Annuals and Perennials, \$1.00. Address B. K. BLISS & SONS, P. O. Box 5712, No. 34 Barclay St., New York.

Turnip Seed by Mail.



The following varieties, the quality of which can not be excelled, will be mailed post-paid to any address in the Union upon receipt of price advised: Early White Dutch, White Strap-leaf, Red-top Strap-leaf, Yellow Aderdeen, Long White or Cow-horn, Improved American Ruta-baga, Carter's Improved Swede, Skirling's Improved Swede, Long White French, Sweet German, 10 cents per ounce, 25 cents 4 ounces, 75 cents per pound. Large Yellow Globe, 60 cents per ounce, 30 cts. 4 ounces, \$1.00 per pound. Prices for larger quantities to dealers, either in bulk or packets for retailing, will be given upon application. Address B. K. BLISS & SONS, P. O. Box, 5,712, No. 34 Barclay Street, New York.

B. K. BLISS & SONS, P. O. Box, 5,712, No. 34 Barclay Street, New York.

DUTCH BULBOUS ROOTS

AND

SMALL FRUITS.

Our Autumn Catalogue of the above, beautifully illustrated with many engravings and a splendidly colored lithograph of a Group of Double and Single Hyacinths, will be ready for distribution Sept. 1. A copy will be mailed to all applicants enclosing Ten Cents; regular customers supplied gratis. Address B. K. BLISS & SONS, SEED, PLANT, & BULB WAREHOUSE, 34 Barclay St., New York. P. O. Box No. 5712.

B. K. BLISS & SONS, SEED, PLANT, & BULB WAREHOUSE, 34 Barclay St., New York. P. O. Box No. 5712.

DWARF PEARS.

A large stock of two-year old trees, very fine. Also Standard Pears, Apples, Plums, Cherries, &c., &c. Inspection invited. Correspondence solicited. NICHOLAS & NEWSON, Geneva, N. Y.

THE BEST STRAWBERRY Yet Out. Somers's Ruby is the most perfect combination of extras in size, beauty, flavor, solidity, and productiveness, ever produced. A few plants for sale in Sept. Price, 2 plants, \$1; 13 plants, \$5. Address WM. SOMERS, Bridgeport, Conn.

STRAWBERRY PLANTS.—One Dozen each of Champion Black Defiance, monarch of the West, Dr. Warder, Matilda, a d. Jucunda, for \$4, post-paid. Boyden's No. 30, @ \$1 per doz. R. H. HAINES, Malden-on-the-Hudson, N. Y.

Strawberry Plants—Charles Downing, Boyden's No. 30, Wilson, Triomphe de Gand, #1 100, #6 1,000. 25 new kinds, by dozen or 100. Send for Catalogue. W. S. CARPENTER & SON, Rye, Westchester Co., N. Y.

New Strawberries—Cumberland, Triumph, and Springdale. For size, flavor, vigor, and productiveness, have no rival. Send stamp for Descriptive Circular. A. MILLET, Box 318, Carlisle, Pa.

Early Beatrice, Louise, and Rivers' Peach Buds, IN LARGE QUANTITIES AND MODERATE RATES. FRANKLIN DAVIS & CO., Nurserymen, Richmond, Va.

Surplus Stock.

PEACH—1 year, fine, \$30 to \$60 per M. CHERRY—2 year, fine, \$30 to \$150 per M. An immense Stock for Nurserymen and Dealers—at lowest rates. See our Surplus Stock List.

THE DINGEE & CONARD CO., Wholesale Nurserymen, West Grove, Chester Co., Pa.

CLAVELACK College and Hudson River Nat. at Clavelack, N. Y. 20 instructors. ALONZO FLAON, Ed. D. Pres.

T U R N I P S E E D

BY MAIL ON RECEIPT OF AMOUNT.

Table listing turnip seeds with columns for 'Per Pound' and seed names like 'EARLY DUTCH', 'GERMAN TELLOW', 'COW HORN', 'RED TOP STRAP-LEAF', 'WHITE NORFOLK', etc.

With all other reasonable Seeds. Catalogues upon application. J. M. THORBURN & CO., 15 John St., New York.

Trees, Vines, Shrubs, Plants, Etc.

500,000 Apple, Pear, etc. 100,000 Peach Trees. 100,000 Grape Vines. 50,000 Currant Bushes. 500,000 Sweet Chestnut Trees. 10,000 Spanish "A. CHESTNUT CIRCULAR FREE. 1,000,000 Evergreens, best in market. 200,000 Deciduous Trees and Shrubs. 50,000 Magnolia Accuminati, one year, fine. 10,000 Tulip Trees, 6 to 12 feet. 2,000 Weeping Mountain Ash. 50,000 Rose Bushes. A new Descriptive Catalogue and Wholesale List free. 21st Year. 40 Acres. 11 Greenhouses. Address, STORRS, HARRISON & CO., Painesville, Lake Co., Ohio.

Plants for Winter Flowering!

Plants for Florists' Stock.

We offer Winter-blooming Carnations (fine) for 20 cts. each; \$15.00 per 100—ready in Sept. Tuberoses, started in pots for winter-bloom, now ready at same price. Chinese Primroses, dbl. white, \$5.00 per doz.; Sluice, \$3.00 per doz. Smilax, large roots, 20 cts. each; \$2.00 per doz. Seedlings ready in Oct. and Nov., at \$1.00 per 100. Violets, Dbl. Blue and Marie Louise, \$8.00 per 100. Begonias, Winter-blooming, extra large, 25 cts. each; \$2.00 per doz.; small plants, \$5.00 per 100. Callas, extra large, \$3.00 per doz.; young plants in Dec., \$3.00 per 100. Bouvardia Davidsoni, fine, 4 in. pots, 25 cts. each; \$2.00 per doz. Cyclamen Persicum, a few 5-year bulbs, at \$1.00 each; general stock, 25 to 50 cts. each; \$15.00 per 100. Dwarf Pomegranates, 15 cts. each; \$1.00 per 100. Roses, tender sorts, grown in pots for winter-blooming, extras, 50 cts. each; 3 to 4 inches, 25 cts. each; \$2.50 per doz. Also our usual supply of young plants for mailing, at 8 for \$1.00. Early White Roman Hyacinths, the earliest and best for forcing, 25 cts. each; \$1.50 per doz.; \$14.00 per 100. Also a large stock of extra size plants of Zonal Geraniums, Fuchsias, &c., for Florists' stock. Our stock is large, and we are bound to sell. General Price List out in Sept. Good judges say we grow the finest Tuberoses bulbs in America. MASSEY & HUDSON, Chestertown, Kent Co., Maryland.

P.S.—Being about to abandon the vegetable seed-growing department, and devote our entire attention to Flowers, we offer for sale about 400 hot-bed sashes, 3 1/2 x 7 feet, at \$2.50 each, delivered in Baltimore.

SUMMER FALLOW.

CARHART'S PATENT TWO-HORSE Pulverizing Cultivator.

As a Pulverizer, Weed, Quack, and Thistle Exterminator, it has no equal.

The extremely low Price of \$22.00 places it within the reach of all.

From the hundreds of testimonials received in its favor we submit the following:

{ Secretary's Office, Patrons of Husbandry, New York State Grange, Elmira, N. Y., June 4, 1874.

BRADLEY MFG Co., Syracuse, N. Y.

Gentlemen:—Three years ago I procured a Carhart Cultivator to use on a summer fallow, infested with Canada thistles—the soil a heavy clay. My original design was to kill the thistles by the slow process of repeated plowings, but I found the work of the cultivator so easy, rapid, and thorough, that I could dispense with the plow and secure the object in view. My success was complete, and the expense of the process was more than one-fourth of the estimated cost, if performed by the plow. Ever since that experiment I have used my cultivator in the various operations for which it is designed, and I am not less pleased with it to-day than I was by its first success. Every season it is kept busy spring and fall by my neighbors, who show thus a proper appreciation of a good implement—for I have plenty of poor ones, which they refuse to borrow. My observation of their work warrants me in saying the Carhart works just as well or porous, gravelly soil, as on my clay. Very Respectfully, W. A. ARMSTRONG, Sec'y N. Y. S. Grange. BELFAST, N. Y., May 2, 1874.

BRADLEY MFG Co.—The Carhart Patent Cultivator came all right, and after trying it I prefer it to the Wheel Cultivator I have formerly used, which cost \$10.00. I. B. FORD.

Send in your address, and we will mail you free one copy of the illustrated Agricultural Economist, giving a complete description of this popular implement, and what Farmers say about it in 1874.

BRADLEY MANUFACTURING CO., Syracuse, N. Y.

Established 1858. Three circular logos for 'PRINCE'S METALLIC PAINT' with '72 lbs Metal in the 100 lbs' and 'WARRANTED FIRE PROOF'.

The best and cheapest Paint in the world for Iron, Tin or Wood. For sale by the Trade everywhere. PRINCE'S METALLIC PAINT CO., Manufacturers, 96 Cedar St., New York. CAUTION.—Purchasers and consumers are cautioned against imitations of our METALLIC PAINT. All genuine PRINCE'S METALLIC PAINT will bear our name and trade mark on each and every package. Send for a circular.

TWO GOLD MEDALS. Illustration of a horse-drawn machine. Text: 'BEST EVER MADE', 'HARDER'S Premium Railway Horse Power, and Thresher and Cleaner, awarded THE FIRST PRIZE, At Great National Trial, at Auburn, N. Y.' 'AWARDED THIS MACHINE'.

Sugar Cane and Sorgo Machinery,

Steam Engines, Horse Powers, Farm Mills, etc. Manufactured by GEO. L. SQUIR & BRO., Buffalo, N. Y. Catalogues free.

Halladay's Improved Wind-Mill. PERFECTLY Self-Regulating. The Best, Cheapest, most Durable and Popular Mill made. Manufactured under the immediate supervision of Inventor 18 years. Two million dollars' worth now in use. Send for Catalogue. U. S. WIND ENGINE & PUMP CO., BATAVIA, ILL.

BUCKEYE DRIER, PAKEE, FEED STEAMER. Illustration of a steam engine.

For full particulars, address ENGLE, KELLER & CO., Lancaster, Pa.

GAWTHROP'S IMPROVED HYDRAULIC RAMS.

Send for Illustrated Circular and Price-List. A. GAWTHROP & SON, Wilmington, Del.

Cheap Farms—on the Ocean. Price \$10 to \$20 per acre. Healthy fish, oysters, &c., abundant; labor cheap and plenty. The best fish and truck region in the States. Several weeks earlier than Delaware, and more certain. Markets—New York, Philadelphia, and Baltimore. By rail, steamer, and vessel. A. P. BURNS, Snow Hill, Md.

THE NATIONAL FAMILY CIDER AND WINE MILL.

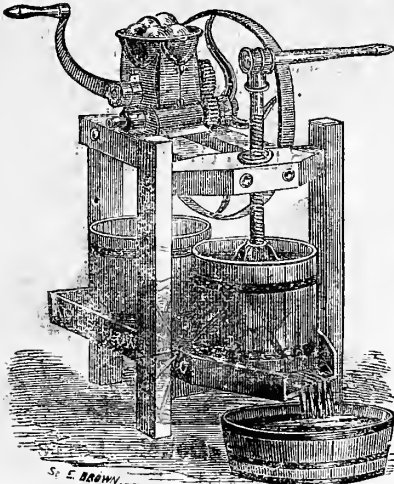

Light, convenient, easily operated, and of low price. Unequaled, and recommended the best in use for Apples, Grapes, Berries, etc. Constructed on entirely new principles, combining both features of grinding and crushing, by which a larger percentage of juice is obtained. Send for illustrated descriptive Circular. Made only by

AMES PLOW COMPANY,
53 Beekman-st, New York,
and Quincy Hall, Boston.

Cider Making Machinery.
HICKOK'S KEYSTONE CIDER MILL.

EXCELSIOR CIDER MILL.
HUTCHINSON'S FAMILY CIDER MILL.
SCREWS, PRESSES, GRINDERS, Etc.
Depot for the sale of the above Mills, in New York City,
60 Courtlandt-st.
Send for Circular. **H. B. GRIFFING.**

THE CHAMPION
Hickok's Patent Portable
KEYSTONE CIDER and WINE MILL.

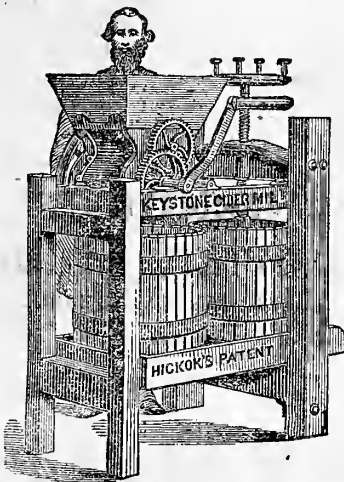

THE BEST MACHINE EVER INVENTED.

I make also two sizes of superior Presses for Berries, etc. If your merchant does not keep them, tell him to send for one for you, or write for one yourself. Don't buy any other until you see this. Send for a circular. **W. O. HICKOK,**
Harrisburg, Pa.

THE HUTCHINSON FAMILY CIDER AND WINE MILL.
(Over 25,000 sold.)

EXCELSIOR CIDER MILL, sr. and jr. Grinds easy and rapid. **Power Apple Grinder.** Pleasant Valley Grape Mill, Presses for Cider and Wine, Press-Screws, &c.
Send for Illustrated Circular.
The New York Plow Co.,
55 Beekman St., New York.

DUGDALE'S Universal Clothes-Washer has been greatly improved, and is sold at the old price, \$3.50. Best in the world for general purposes. In time, power, quality, and amount of work. Agents wanted. Circulars free. Weight 4 lbs.
J. K. DUGDALE, Whitewater, Wayne Co., Ind.

ADVERTISERS should send to **Geo. P. ROWELL & Co.,** 41 Park Row, N. Y., for their *Eighty-page Pamphlet*, containing lists of 3,000 newspapers and estimates, showing the cost of advertising. Mailed free to all applicants.

BLAKE'S PATENT STONE & ORE BREAKER.

New Pattern, with Important Improvements & Abundant Strength.

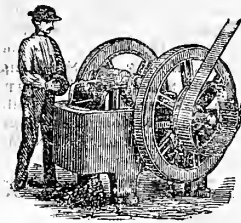

For reducing to fragments all kinds of hard and brittle substances, such as **STONE** for making the most perfect **MACADAM ROADS**, and for making the best **CONCRETE**. It breaks stone at trifling cost for **BALLASTING RAILROADS**. It is extensively in use in **MINING** operations, for crushing

IRON, COPPER, ZINC, SILVER, GOLD, and other ORES. Also for crushing **Quartz, Flint, Emery, Corundum, Feldspar, Coal, Barytes, Manganese, Phosphate Rock, Plaster, Soapstone, etc.** For Illustrated Circulars and particulars, address

BLAKE CRUSHER CO., New Haven, Conn.
Persons visiting New York, can be shown a crusher in operation at 137 Elm Street.

CIDER MILLS.

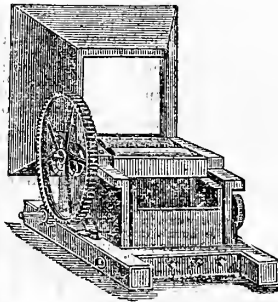

The most perfect Cider Apple Grinder in use, in grinding fast and fine, and giving the best satisfaction.

Price, \$40.

I have also the easiest, handiest, quickest working, and most powerful Press in use.

Send for Descriptive Circulars.

Address **MARCUS P. SCHENCK,**
Fulton, N. Y.

THE FARMER'S Favorite Cider Mill.

Buy no Cider Mill until you have examined the **Farmer's Favorite**. It is the best built, cheapest, and most durable Mill in market.

It will produce 25 per cent more juice from the same amount of cheese, than any other mill manufactured. Send for Descriptive Circular. **HIGGANUM MANUFACTURING COMPANY,**
Higganum, Conn.

MAGIC PHOTOGRAPHS.

Wonderful! Curious! Amusing!

25 cents a package; 5 assorted packages \$1; one dozen assorted packages \$2. Sent to any address, postage paid, on receipt of price. Address **PUZZLE COMPANY,** 733 Broadway, New York.

FIRST Premiums awarded by Amer. Inst., 1870.

MICROSCOPES.

Illustrated Price-List sent free on application.

MAGIC LANTERNS.

Catalogue, priced and illustrated, sent free.

T. H. McALLISTER, Optician, 49 Nassau-st., N. Y.

\$200 A MONTH TO AGENTS

to sell the IMPROVED "HOME SHUTTLE" SEWING MACHINE, a practical, low-priced "Lock Stitch" Sewing Machine. Address **JOHNSON, CLARK & CO.,** Boston, Mass.; New York City; Pittsburgh, Pa.; Chicago, Ill.; Louisville, Ky.; or St. Louis, Mo.

The Hutchinson Burner.

(Price, 35 Cents, by Mail.)

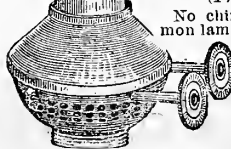

No chimney needed. Fits the common lamps, and burns kerosene with a clear, steady flame two inches high, or any less light desired. For safety, convenience, and economy, unequalled. Sent by mail for 35 cents; two for 60c., with wicks. Write to **HUTCHINSON & CO.,** Cayuga, N. Y.

QUINBY'S NEW SMOKER.—Best method yet devised for quieting bees. Can be sent by mail in two parts, price \$1.75. By express \$1.50. Send for circular and price list. **M. Quinby,** St. Johnsville, N. Y.



Improved Foot Lathes.

Small Engine Lathes, Small Gear Cutters, Hand Planes for Metal, Ball Turning Machines, Slide Becks, Foot-Scroll Saws. The very best. Selling everywhere. Catalogues free. **N. H. BALDWIN,** Laconia, N. H.
Just the articles for Artisans or Amateurs.

MEDAL MACHINES.
NEW YORK STATE AGRICULTURAL WORKS.

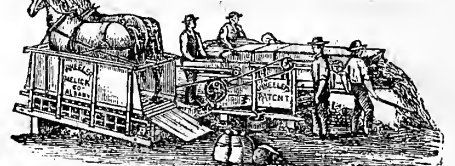

WHEELER & MELICK CO.,

Patentees and Manufacturers of **RAILWAY, CHAIN AND LEVER HORSE POWERS, THRESHERS AND CLEANERS, THRESHERS AND SHAKERS, CLOVER HULLERS, FRED CUTTERS, ITHACA WHEEL HORSE RAKES, HORSE PITCHFORKS, SHINGLE MACHINES, STRAW PRESERVING RYE THRESHERS, &c., &c.**

Send for Circular. **ALBANY, N. Y.**

Straw Preserving Thresher.



This Machine leaves the straw straight and unbroken, when it can again be put into bundles, making it more valuable for market. **WHEELER & MELICK CO.,** Sole Manufacturers, Albany, N. Y. Send for circular.

The Lightning Peach-Parer.

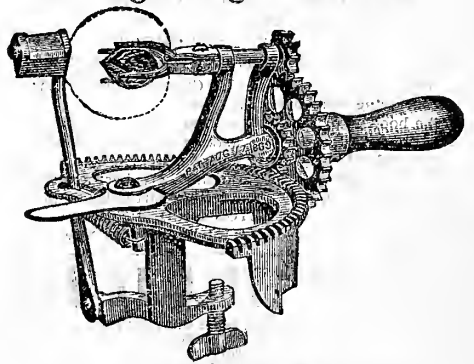

The only practical Peach-Parer made.

It pares Apples as well as the best Apple-Parers. Sold in all large markets.

D. H. GOODELL, Sole Manufacturer, Antrim, N. H., and 99 Chambers-st., New York. Also manufacturer of Improved Turn-Table Apple-Parers, Lightning Apple-Parers, Climax Cores and Slicers, Cahoon's Broadcast Seed-Sowers, etc.

Lovejoy's New Style GLASS CUTTER AND PUTTY KNIFE

Cuts glass better than a diamond. Everybody should have one. Any child can use it. Sent to your address on receipt of 50 cents and stamp by **ALVAN L. LOVEJOY,** 229 Washington St., Boston, - - - Mass.

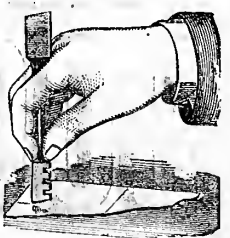

Liberal discount made to dealers.



BUILDING FELT.

This water-proof material, resembling fine leather, is for outside work (no tar substances used) and inside, instead of plaster. Felt carpets, etc. Send two 3-cent stamps for circular and samples. **C. J. FAY,** Camden, N. J.

New Church Music Book, For 1874,—1875.

THE LEADER!!

By H. R. PALMER and L. O. EMERSON,
the most successful Church Music Book makers of the day.
Will be ready in August, and will contain the usual Sing-
ing School Course, and a large amount of new and choice
music for Choirs, Conventions and Singing Classes. Spec-
imen Pages now ready, and will be mailed, post-free, on
application.

Price, \$1.38, or \$12.00 per dozen.

The Emerson New Method FOR REED ORGANS.

By L. O. EMERSON and W. S. R. MATTHEWS. \$2.50. One
of the Newest and very best of the New Methods.

GUIDE IN THE ART OF SINGING.

By Geo. L. Osgood, \$4.00.
New and very superior book for Voice Training.

Richter's Manual of Harmony.

Translated from the eighth German edition, by
J. C. D. PARKER. Price \$2.00.
Prepared expressly for the Leipzig Conservatory, and is a
complete and reliable Grammar of Composition.
OLIVER DITSON & CO., CHAS. H. DITSON & CO.,
Boston, 711 B'dway, New York.

OUR FIRST 100 YEARS!

The Life of the Republic Illustrated.

BY C. EDWARDS LESTER.
Published in 12 monthly parts, 64 pages, at 50c. each. Sent
by mail, prepaid, in territory where no agent is working.
Do not wait for the agent, but send 50c. for Part One, now
ready; the balance will be delivered by the agent. Agents
wanted in every School District. Address
UNITED STATES PUBLISHING CO.,
18 University Place, N. Y.

A Timely Book for Agents.

THE LIFE AND PUBLIC SERVICES OF SALMON PORTLAND CHASE,

LATE CHIEF-JUSTICE OF THE UNITED STATES;
Formerly United States Senator, Governor of Ohio, and
Secretary of the Treasury.

By J. W. SCHUCKERS,
For many years Private Secretary to Mr. Chase.

This is the only Life of the late Chief-Justice authorized by
the surviving members of his family.

The book is printed on good paper, in clear, large type,
and illustrated, the whole making a volume of about 650
pages, and sold only by Subscription.

Price, in elegant Cloth Binding, \$5; Leather, \$6; Half
Turkey Morocco, \$7.50. For further particulars apply to
D. APPLETON & CO., Publishers,
549 & 551 BROADWAY, NEW YORK.

AGENTS WANTED FOR 'TELL IT ALL.'

By Mrs. Stenhouse of Salt Lake City, 25 years the Wife of a
Mormon High Priest. With Introduction by Mrs. Stowe.
Over 3000 *Outfits* of this new work were ordered by *old Agents*,
in advance, who are now selling 25 to 40 a day! Its sale is
without parallel. One lady sold 280 in one week. Terms big;
sales positively immense. We send *Outfit free* to any one
who will canvass. *Agents wanted everywhere.* Circulars free.
Address, A. D. WORTHINGTON & Co., Hartford, Conn.

BAIRD'S BOOKS

For Practical Men.

My new revised and enlarged Catalogue of PRACTICAL
AND SCIENTIFIC BOOKS, 96 pages, 8vo., will be sent,
free of postage, to any one who will favor me with his ad-
dress. HENRY CAREY BAIRD,

Industrial Publisher,
406 Walnut St., Philadelphia.

WEBSTER'S POCKET DICTIONARY OF THE ENGLISH LANGUAGE.

Abridged from Webster's Quarto, illustrated with nearly
TWO HUNDRED Engravings on Wood. This volume em-
braces a careful selection of more than 18,000 of the most im-
portant words of the language. The introduction contains,
besides the Pictorial Illustrations, **Tables of Money,
Weight and Measure, Abbreviations, Words,
Phrases, Proverbs, Etc.**, from the Greek, Latin, and
the Modern Foreign Languages, **Rules for Spelling,**
etc., etc.; making all together the **most complete and
useful pocket companion extant.** It is beautifully
printed on tinted paper, and bound in Morocco, Tucks, gilt
edges, \$1. *For sale everywhere.* Sent by mail on receipt
of the price.

IVISON, BLAKEMAN, TAYLOR, & CO.
PUBLISHERS,
138 & 140 Grand Street, New York.

Herald of Health.

This monthly is devoted to the culture of the body and
mind; to rearing healthy and beautiful children; to the re-
covery of health without drugs; to the improvement of the
physique; and to showing people how to live so as to be
healthy, happy, and make the most of life. The Scientific
American says: "It contains more sensible articles than
any monthly that comes to our sanctum." \$3.00 a year, with
a premium of the complete works of Shakspeare, in one
volume of over 1,600 pages and 36 illustrations.
WOOD & HOLBROOK, 13 and 15 Laight St., New York.

"EDEOGRAPHY." A new book on the art of
Writing by Sound; a com-
plete system of Phonetic Short Hand—the shortest, most simple,
easy, and comprehensive, enabling any one, in a short time, to report
trials, speeches, sermons, &c. The Lord's Prayer is written with
forty-nine strokes of the pen, and 140 words per minute. The unem-
ployed should learn this art. Price, by mail, 50 Cts. Agents wanted.
Address T. W. EVANS & CO., 139 S. Seventh Street, Phila., Pa.

PIANOS for Rent. with *Privilege of Purchase.* We Rent
elegant *first-class* Pianos at very mod-
erate rates, and allow the rent to pay
for the instrument. By our new
rental system a person can have from
Two to Seven Years to pay for a
Piano. Any responsible person wish-
ing a *first-class* Piano on *Easy Pay-
ments* should send stamp for our new Illustrated Catalogue
with full particulars. Address
S. BRAINARD'S SONS, Cleveland, Ohio.

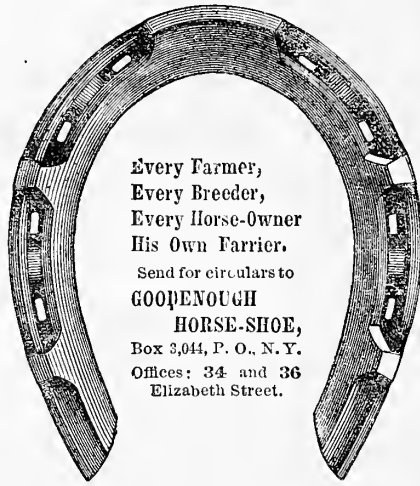

Every Farmer,
Every Breeder,
Every Horse-Owner
His Own Farrier.

Send for circulars to
GOOPENOUGH
HORSE-SHOE,
Box 3,044, P. O., N. Y.
Offices: 34 and 36
Elizabeth Street.

MY NEW
HAY, STRAW, AND STALK CUTTER.
Not to be paid for until tried on your farm, and found
satisfactory. Splendid chance for agents. Circulars free.
WARREN GALE, Chicopee Falls, Mass.

AGENTS WANTED. No Humbug.
The Stone Knife, Scissor, and Tool Sharpener,
the best selling article in the market, 100 per cent. profit.
Samples mailed for 25c.
Italian Stone Co., Binghamton, N. Y.



PATENT
GRAPE
Picker.

A very useful, labor-saving article. Sent post-
paid on receipt of \$1. AGENTS WANTED.
Address VALENTINE & CO.,
Bristol, Conn.

GRAPE-VINES.

LARGEST STOCK IN AMERICA. Extra quality.
Reduced prices. T. S. SUBBANS, Freeonia, N. Y.

PENNSYLVANIA AGRICULTURAL WORKS.

Manufacture the celebrated Farquhar Threshing Ma-
chines, Railway and Sweep Horse-Powers, Cultivators. Cul-
ticator Teeth, Plow Handles, and Agricultural Implements
generally. Send for circulars. Please address

A. B. FARQUHAR, Proprietor.
WORKS, YORK, PA. 56 Beckman St., New York.

THE DRILL OF THE PERIOD.



The Superior Double Force-Feed GRAIN DRILL

Has met with unparalleled success during the past two
years, and now stands without a rival in the Grain Drill
family. It is the only Double Force-Feed Drill in
the world. Thousands of farmers who have bought and used
the "Superior," pronounce it *entirely unequalled* for per-
fection of work, ease of operating, grain saving, time sav-
ing, and money making. Don't fail to examine it and com-
pare it with other Drills before purchasing.

THOMAS, LUDLOW & RODGERS,
Manufacturers, Springfield, Ohio.
Also exclusive manufacturers of the celebrated Im-
proved Buckeye and Champion Cider Mills.
Send for Circulars.

PLUM TREES.

50,000 splendid two-year trees—cannot be surpassed, if
equaled, by anything in this country.

CHERRIES AND PEACHES.

A large stock, including all the new varieties.
Also, a general Nursery Stock, very fine. Send for Price
List. NICHOLAS & NEWSON, Geneva, N. Y.

THE PULSOMETER.



The simplest, most durable, and effective
steam pump now in use. Will pump gritty or
muddy water without wear or injury to
its parts. It can not get out of order.

C. HENRY HALL & CO.,
20 Cortlandt Street, New York City.
BRANCH DEPOSITS:

104 Sudbury St., Boston, Mass.
1,327 Market St., Philadelphia, Pa.
59 Wells St., Chicago, Ill.
South Western Exposition, New Orleans, La
811 and 813 North Second St., St. Louis, Mo

GENUINE Peruvian Guano.

In Large or Small Quantities.

Circular, containing testimonials, references, and full par-
ticulars, mailed free on application to

R. BALCAZAR,
P. O. Box 129. No. 53 Beaver Street, New York.



Buy the Best Fertilizers.

H. B. GRIFFING,
58 and 60 Cortlandt Street, New York.

FOR SALE--MANURE

from 180 horses for a year. For particulars, apply to the
TROY & LANSINGBURGH R.R. CO., Lansingburgh, N. Y.



Patent Concave Ox-Shoes.

The only forged ox-shoe made
with *concavity* to fit hoof, and the
best and cheapest.
GREENFIELD TOOL CO., Greenfield, Mass.

ALL FARMERS should know what min-
erals are on their lauds. For particulars address
WM. L. BILLIN,
P. O. Box 2,844. Philadelphia, Pa.

AGENTS LOOK!--\$12 a day made selling
A Seissors Sharpener and other wares. Sample 25 cts. Cat-
alogue free. T. J. HASTINGS & CO., Worcester, Mass.

Steamed Food and Ruminations.—"T. W. C.," Melrose, Mass. If any person has hazarded the statement that cows do not chew the cud when they are fed upon steamed food, he is certainly much mistaken. There is nothing unnatural about the practice of feeding this food any more than in grinding the corn or oats instead of feeding it whole. It is simply making the food more easily eaten, more palatable, and more digestible. Each of these effects is an economy, and the only question to be considered by the farmer is the matter of convenience. The economy and propriety of cooked food is well settled.

A Question in Dairying.—"Inquirer," St. Charles Co., Mo. We should say that there is no question as to the profit of keeping cows for the dairy upon purchased feed when hay may be bought for \$5 to \$8 per ton, corn at 30 to 50 cents per bushel, and oats 20 to 25 cents, with milk at 2½ cents per quart at a creamery near by. Under such circumstances, with a run-down farm we should keep all the cows we could procure and find room for, selecting, of course, good milkers. A good milker should yield 1,800 to 2,000 quarts in the year and raise a calf. If there were only the manure pile and the calf for profit it would pay. Every possible arrangement should be made to save the manure, both liquid and solid, and if the funds are to be had it would be an economy to steam the food. Dairymen in both Eastern and Western States, where feed is worth much more than the above prices, are making money with milk at 2½ cents a quart.

A Harrowing Question.—"Inquirer," It is difficult to say when a perfect harrow will be invented, or when we shall have one that will meet every expectation. The uses of the harrow are constantly extending, and every new use to which we apply it brings to light some new improvement. We can not, therefore, expect to have any one harrow that will meet every requirement of the farmer; on the contrary the more exacting he is as to the quality of his work the greater variety of harrows he will find useful to him.

Value of Leaves.—"J. H. B.," Chester Co., Pa. There is not much difference between the value of a ton of leaves, or that of a ton of straw, as manure. The percentage of ash is slightly greater in leaves than in straw, but the valuable constituents of the ash, as lime, potash, and phosphoric acid, are about the same.

Losing the Hair.—"T. J. S.," Tippicanoe, Ohio. When cows are fed with steamed food and kept in a warm stable during the winter, the usual period of shedding the hair is anticipated and considerable irritation of the skin is frequently noticed before the hair loosens. The cows are uneasy and rub themselves continually. The use of too much corn-meal produces the same effect, it being what is called "too heating." Some wheat bran or linseed cake meal should be fed with the corn, and salt should be given sparingly. A small quantity of sulphur should be given in the feed twice a week from January until the irritation of the skin disappears. There is not a book on "cattle," and probably never will be one, which can meet every circumstance which will arise in the care of stock. Much must of necessity be left to the judgment and experience of the owner.

Protrusion of the Rectum in Fowls.—"George," Wellesly, Mass. It is not unusual for the egg passage in fowls to become relaxed and protrude in a reverted position. In this case the parts should be bathed in some gentle, cooling, astringent lotion, as cold tea, alum water, or a weak solution of copperas. It should be immediately returned, and a piece of sponge moistened with the liquid or with tincture of opium should be bound upon the part by means of a suitable bandage. A pill of bread soaked in the tincture should be given to the fowl, and it should be confined in a dark, quiet place for a day or two. If the protrusion is repeated the fowl may be considered as incurable.

Use of Corn-Cobs.—"G. E. H.," Schuylerville, N. Y. We would rather burn corn-cobs if they can be procured in large quantities and spread the ashes than use them in any other way.

Price and Value of Plaster.—"E. H. M.," Danbury, Ct. Gypsum, or plaster, is a salt of lime containing a large proportion of water. It consists of 32.5 per cent of lime, 46.5 per cent of sulphuric acid, and 21 per cent of water, when pure. There is a bed of gypsum of excellent quality at Manlius, N. Y., and it also occurs abundantly from Syracuse westward to Genesee County. All through this district it can be mined and sold profitably at \$3 per ton, as it is brought to this country from Nova Scotia and sold for \$4 a ton. Our native gypsum is equally as good as the foreign. The man-

ner in which plaster acts as a fertilizer has been the subject of much discussion; it is soluble in water and can supply both sulphur and lime to the plant; it also has the property of fixing free ammonia, and some claim that this is its principal office.

Crop for Wet Soil.—"G. W. F.," E. Brookfield, Mass. The best crop for a rather wet soil would probably be oats. If the land is plowed in narrow ridges of ten to sixteen feet with deep, open furrows between them, the crop would suffer less from the wet. But before laying down to grass such land should be drained. Potatoes should never be planted on wet soil; they succeed best upon dry, warm land.

Improving a Cold Clay Pasture.—"Old Subscriber," Taunton, Mass. The first thing to be done to improve a cold clay pasture is to drain it. It should then be well harrowed to tear up the moss and loosen the soil upon the bare spots, and dressed with fifty bushels of lime per acre. Clover and timothy seed should then be sown and the surface rolled or again harrowed. If a fair dressing of fine manure could be given in the fall so much the better.

Draining Sandy Soil.—"W. T. L.," Marshall, Texas. There may very easily be a draining mania as any other kind; and the idea that every soil needs draining, whatever may be its character, savors much of such a mania. A sandy soil with a clay subsoil does not necessarily need draining. It is more than probable that the "clay" subsoil itself contains a large proportion of sand, and is not really a clay. If it should be broken up by subsoiling it would probably be all that is needed. We would advise an experiment of this kind before expending money upon drains.

Spasmodic Colic.—"G. F. J.," Mason Co., Texas. The readiest remedy for spasmodic colic in horses is to give an injection of warm water (not hot) with plenty of soap and a handful of salt dissolved in it. The horse should be walked about to excite the bowels to action. The injection may be given by means of a bladder with a pipe of elder, or other wood, made smooth and greased before using.

Wild Onion—Bermuda Grass.—"H. B. R.," Greenville, S. C. There is no thoroughly effective means of getting rid of these weeds but by summer fallowing, with several plowings and frequent harrowing. The roots of the grass must be picked off after each plowing or harrowing.

To Stimulate the Growth of Hair.—"G. W. E.," Walden, N. Y. The growth of hair upon the mane and tail of a horse may frequently be stimulated by rubbing the skin with a mixture of common whi-key and tincture of cantharides. If the follicles of the skin from which the hair grows have been destroyed by disease or other causes, it is not probable that any application will be effective.

Value of Gas Lime.—"Old Subscriber," Philadelphia. We have not a high opinion of the value of gas lime. We would rather pay twenty cents a bushel for ordinary lime than have gas lime brought to our place and delivered free. As an absorbent in place of plaster it is worse than useless. When gas lime is fresh it contains much sulphuretted hydrogen which it has absorbed from the gas in the process of its purification. This is poisonous to vegetation, and until it has passed off on long exposure to the air the gas lime should not be used for any agricultural purpose. By the action of the air some gypsum or sulphate of lime is produced, and the rest is mainly carbonate of lime, or what is known as mild lime, and of little use for any purposes.

How to Catch Hawks.—"A. K.," Lunenburg, Mass., sends us his plan of trapping chicken hawks, as follows: "Take a wire bird-cage, put a live chicken in it, and set it on the ground near the buildings in an exposed place. Then take a steel trap, tie a small dead chick on the pan. Then place a small stick about an inch and a half long under the chick's throat, so as to bring the head in the natural position. Open the chick's eyes, and he will look as if alive. Place the trap on the ground about three feet from the live chicken in the cage and set it. Shut up all the young chickens. When the hawk comes, he will hear the live chicken calling for its mother, and will go for it. But as he can not take it, he will quickly see the chicken on the trap and clutch it in a moment. Then you have him."

Epilepsy in Pigs.—"W. E. M.," Ash-tabula Co., Ohio. Pigs are very subject to epilepsy, probably because no animals are so subject to internal parasites, to the presence of which this affection is often attri-

buted. The attack occurs without any previous symptom. The pig suddenly staggers, drops upon his haunches, foams at the mouth, becomes rigid, and falls; the eyes protrude and are turned upwards, the muscles are violently convulsed, and the animal struggles involuntarily and unconsciously. Recovery is often very speedy, and the animal regains consciousness and goes about its business again. It is supposed that worms in the stomach and intestines, or minute eggs and larvae of parasites in the blood or the muscles, are the chief causes, although sometimes defective nutrition by reason of indigestion may doubtless produce it. An ounce of turpentine given daily twice, and followed by an ounce of castor oil, or two ounces of linseed oil, or an injection of soap and water in the rectum, has been recommended as proper treatment; but these are of doubtful benefit.

Inflammation of the "Hook."—"E.," Madison, O. When the covering membrane of the eye of an ox is seriously inflamed after the loss of the eye, it may be removed without injury either with a sharp knife by a surgeon or by the application of nitrate of silver in solution. The fungoid growth which occurs under such circumstances must be removed before there can be any cure. It would be best to have some professional advice about it.

Restoring Butter.—"J. O. B.," We know of no method of restoring rancid butter to a good condition. The ill smell and flavor is caused by a chemical decomposition of some of the constituents and the formation of some peculiar acids which can not be got rid of nor effectually disguised after they are once formed.

A Sheep with a "Propensity."—"B. S. H.," Tarrytown, N. Y. Sheep have a natural propensity for eating bark, which is incurable. They should not be allowed in a young orchard, and it is not safe to keep them in an old one for many days at a time. When they have become at home there they will be on the lookout for mischief.

Wart on a Horse's Breast.—"E. D.," Labette Co., Kansas. If the wart is small it may be removed by tying a stout fine cord or a fine iron wire tightly around the base. It will in time drop off. Otherwise it may be removed by touching it daily with a strong solution of nitrate of silver (lunar caustic). Be careful in using this solution, as it is poisonous.

The Best Sheep for Ohio.—"S. C.," Pomeroy, Ohio. If we should judge by the practice and success of sheep farmers in Ohio we should say that the Merino and its grades are the most profitable sheep in that State. What is the best sheep depends greatly upon the locality. It is certain that there are comparatively few places in which the large long-wool sheep can profitably supersede the full blood and the three-quarter or half-bred Merino. Those few places are where a large carcass of mutton is desirable, and where abundant pasture and roots are attainable. It must be remembered that by far the largest demand is for fine and three-quarter clothing wools, or, in other words, Merino wools, and that the demand for combing wools is far from general. Few common country woolen factories are able to card the long wools, and such factories use up the great bulk of the wool produced here.

Dick's Success.—"J. S.," Union Grove, Ill., relates the following story about Dick. He was called the Elephant from his immense size. He weighed alive 768 pounds at the age of two years. By that time he had eaten 40 bushels of corn, three liters of young pigs, three calves, and two dozen hens and chickens, all of which charged against him amounted to \$34. Dick required the services of four men and a span of horses to dress him, when he made 614 lbs. of pork, and sold for \$24.56. The balance against him is made up of little items which are not usually charged; otherwise he would have been a profitable pig. He was a Poland-China, and an ornament to his race. In one of his frisky moments he injured his back, and was therefore killed before he was fattened. "J. S." thinks if he could only raise a lot of hogs like Dick he would do well.

Bloody Urine.—"C. A. N.," Morristown, N. J. The cause of bloody urine in a cow after calving is a congested state of the blood-vessels of the kidneys consequent upon the recent condition of the cow. It is always accompanied by some fever, and a cooling aperient draft frequently relieves it at once. We would give 12 to 16 ounces of Epsom salts with an ounce of ground ginger, and apply cold, wet cloths to the loins. No corn-meal should be given, and linseed cake-meal should be substituted. Scalded crushed oats, given cold, may be alternated with the linseed. It is also advisable to keep the cow quiet for a few days and feed lightly.

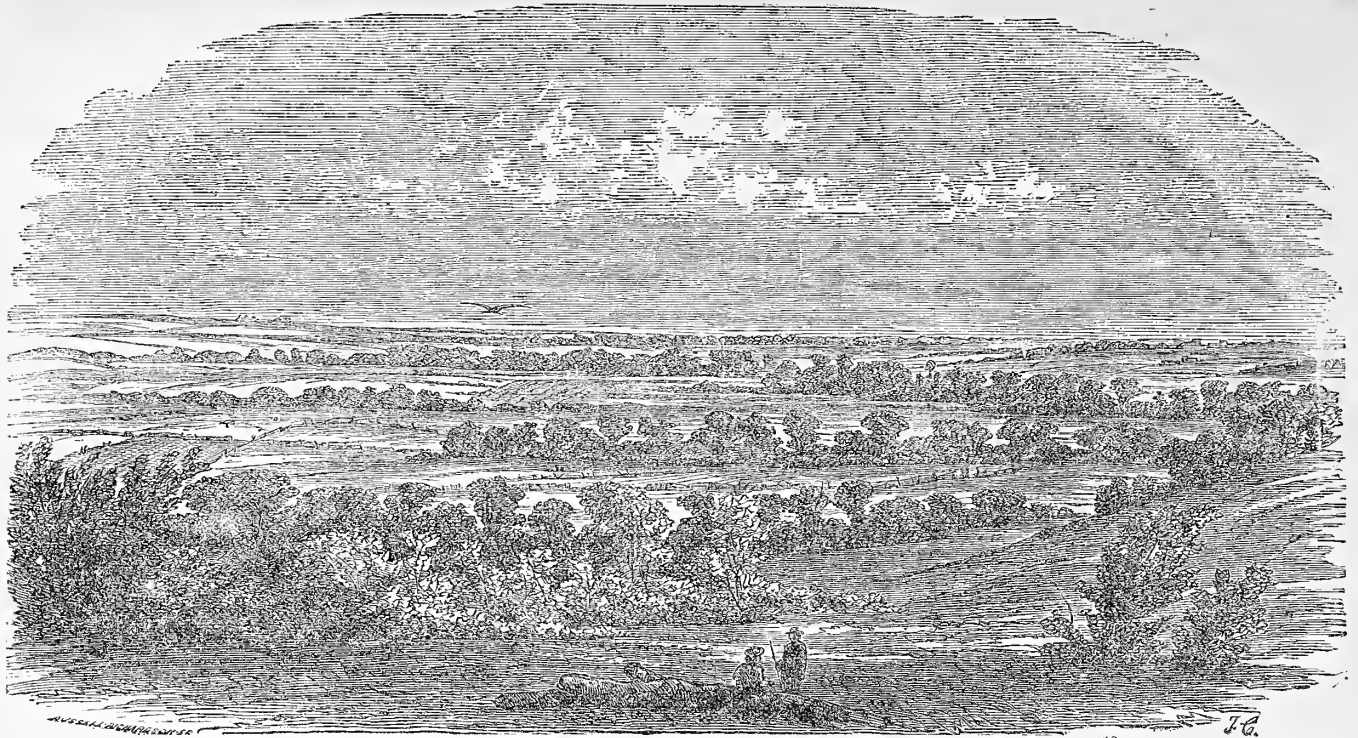

LOOKING UP THE WEST BLUE, FROM THE FORKS OF BIQ AND WEST BLUE, NEB. 13

IF YOU WANT A FARM OR HOME, YOU SHOULD BUY OF THE BURLINGTON AND MISSOURI RIVER RAILROAD CO. IN IOWA OR NEBRASKA.

BECAUSE—Their prices are low, ranging for the best land from Three to Ten Dollars per acre.
BECAUSE—No payments are required of the purchaser for four years, except interest at six per cent.
BECAUSE—After the fourth year only one seventh of the principal is payable annually till the whole is paid.
BECAUSE—You are not required to go into a wilderness, these being well-settled States, the population of which is rapidly increasing.
BECAUSE—The mildness of the climate and fertility of the soil is such that the settler can pay for his farm from the products raised upon it long before the time when the principal becomes due.
BECAUSE—Failure of crops from drouth is unknown.
BECAUSE—Large allowances are made upon fare and freight, thus giving low rates on both to purchasers of this Company's lands.
AND YOU SHOULD BUY THIS YEAR.
BECAUSE—Purchasers of our lands in Nebraska during 1874 who cultivate one-half their land within two years from their purchase are allowed a reduction of twenty per cent on its price. **LARGE DISCOUNTS** also, FOR CASH, within One, Two, or Five Years.
 Send for Circulars, with full information on all points, to

GEO. S. HARRIS, Land Commissioner,
At Lincoln, Nebraska, for land in Nebraska. At Burlington, Iowa for land in Iowa.
JAS. R. WOOD, General Agent, 59 Clark St., Chicago, Ill.

Or to **W. D. COWLES**, General Agent, 317 Broadway, New York.

**EVERY LADY SHOULD HAVE A SET OF
GOODRICH'S "SPRING" HEMMERS**
 Consisting of Four Widths and a Dress Binder. Sent by Mail on Receipt of Price.
 For Sale by all Sewing Machine Agents. } **H. C. GOODRICH**, {205 State Street, CHICAGO, ILL.
 Price, Only One Dollar. } 103 N. 10th St., PHILADELPHIA, PA.
 Inventor of The Goodrich Tuck Marker.

Lake Superior and Mississippi R.R.
 SAINT PAUL, June, 1874.
 This Company has for sale large tracts of Land, in the vicinity of its Railroad, on which are extensive wild **Cranberry Marshes**, from which several **Thousand Bushels** were gathered in 1873. To any person acquainted with the culture of Cranberries, rare opportunities are offered. Address
JNO. P. ILSLEY,
 PRESIDENT AND LAND COMMISSIONER.

Samples from
B. E. Hale & Co.,
 56 and 58 Park
 Place, N. Y.
 Sole Agents for
 Eastern States.

BUILDING PAPER!
 FOR SHEATHING, ROOFING, DEAFENING, CARPET LINING AND PLASTERING.
 Company,
 Chicago, Ill.

Self-Propel-For Cripples
 Can be easily in or out doors, using the use of State your weight for illustrated ferent styles and
 Please mention this paper.



ling Chairs and Invalids propelled, either by any one hand, and send stamp catalogue of dil-pices.
S. A. SMITH,
 No. 32 Platt St.,
 N. Y. City.

THE BREECH-LOADER. By "GLOAN." FULLY ILLUSTRATED.

CONTENTS.
 How to Load the Breech-Loader.
 Powder for the Breech-Loader.
 The New Explosives.
 Shot for the Breech-Loader.
 Wadding for the Breech-Loader.
 Concentrators for Breech-Loaders.
 The Breech-Loading Gun Case.
 A Model Gun Chest.
 How to Clean a Breech-Loader.
 The Dead Shot.
 How to Aim.
 The Value of Field Sports.
 Game Laws.
 Field Philosophy.
 Price, post-paid, Two DOLLARS.

ORANGE JUDD COMPANY, 245 Broadway, N. Y.

Carbonized Enamel IS AS PURE AS GLASS. The Bridgeport Mfg Co., OF BRIDGEPORT, CONN.

(Office, No. 88 Chambers St., New York),
Have the exclusive control of this valuable enamel, and are using it to cover all of their celebrated

American Submerged Force Pumps.

They also enamel pipe inside and out, which delivers the water chemically pure. The Enamel is composed of vegetable matter, baked on so hard that a blow does not break it, and it resists acids that eat gold.

Gentlemen: I have examined the sections of Carbonized Enamel Pipe submitted to me by you. It is superior to any pipe I have ever seen for resisting acids and conducting water from springs or for use in connection with pumps, etc. The Enamel adheres with astonishing tenacity, withstanding even heavy blows; and the surface of the metal where the enamel is beaten off seems to be protected against the ordinary action of water.

M. C. WELD,
Late Associate Editor *Am. Agriculturist*.

MUDGE & WOODS, No. 88 Chambers St., N. Y., are the exclusive selling agents of the Bridgeport Mfg Co. for the Licenses of States, counties, and towns rights for the American Submerged Suction and Force Pumps.

\$290 Piano. Circulars free. U.S. Piano Co. 810 B'dway, N.Y.

LOVEJOY'S METALLIC WEATHER HOUSES
 Indicate the changes in the weather, and are pretty mantel ornaments. The little lady appears in fair and the man in stormy weather, and they never make mistakes. Sent prepaid to any address, safely packed, upon receipt of \$2 (Two), by **ALVAN L. LOVEJOY**, Proprietor and Manufacturer, 229 Washington St. Boston.
 Special price to dealers.

Newly Revised and Enlarged Edition.

Practical Floriculture.

A Guide to the Successful Propagation and Cultivation of Florists' Plants.

By PETER HENDERSON,

Author of "Gardening for Profit."

Beautifully Illustrated. Price, Post-paid, \$1.50.

In this work, which has everywhere become so deservedly popular, not only is the whole "art and mystery" of propagation explained, but the reader is taught how to plant and grow the plants after they have been propagated. The work is not one for florists and gardeners only, but the amateur's wants are constantly kept in mind, and we have a very complete treatise on the cultivation of flowers under glass, or in the open air, suited to those who grow flowers for pleasure as well as those who make them a matter of trade. The work is characterized by the same radical common sense that marked the author's "Gardening for Profit," and it holds a high place in the estimation of lovers of floriculture. The new edition has been thoroughly revised by the author, and much enlarged by the addition of valuable matter.

The following are a few of the subjects embraced in the latest edition:

Laying out Flower Garden and Lawn; Designs for Grounds and for Greenhouses; Soils for Potting; Cold Frames; Hot-Beds; Greenhouses Attached to Dwellings; Modes of Heating; Propagation of Plants by Seeds and by Cuttings; Culture of the Rose and Tuberoses; Growing of Winter-flowering Plants; Construction of Bouquets, Baskets, etc.; Parlor and Window-Gardening; Wardian-Cases and Ferneries; Insects; What Flowers Grow in the Shade; Culture of Grape-Vines under Glass; The Profits of Floriculture; How to Become a Florist, etc., etc.

THE ILLUSTRATED Book of Poultry,

With Practical Schedules for Judging, Constructed from Actual Analysis of the Best Modern Decisions.

By LEWIS WRIGHT,

Author of "The Practical Poultry Keeper," "The Brahma Fowl," etc.

ILLUSTRATED WITH Fifty Colored Portraits of Prize Birds,

Painted from Life by J. W. Ludlow.

CONTENTS.

CHAP. 1.—Houses and Accommodation.	CHAP. 19.—Brahmas.
2.—The Selection of Stock.	20.—Malays.
3.—Feeding and General Treatment of Fowls.	21.—Game.
4.—Eggs and Incubation.	22.—Dorkings.
5.—Artificial Hatching.	23.—Spanish.
6.—The Management of Chickens.	24.—Hamburghs.
7.—Fattening and Killing.	25.—Polish Fowls.
8.—Poultry as National Food.	26.—French Breeds of Poultry.
9.—The Utility of "Fancy Points."	27.—American Breeds of Poultry.
10.—Commencing a Strain.	28.—Unclassed Varieties of Poultry.
11.—Mating Stock for Breeding Prize Birds.	29.—Bantams (Except Game).
12.—Rearing, Care, and Exhibition of Prize Poultry.	30.—Game Bantams.
13.—Shows and Judging.	31.—Wild Breeds of Poultry, Origin of the Domestic Fowl.
14.—Buying, Selling, and Exporting.	32.—The Guinea Fowl.
15.—Enemies in the Yard.	33.—The Turkey.
16.—Diseases of Poultry.	34.—The Pea Fowl.
17.—Technical Terms.	35.—Ducks.
18.—Cochins.	36.—Geese.
	37.—Swans.
	38.—Possible Additions to the Poultry Yard.

Price, Postpaid - - - - \$15 00

Either of the above books sent post-paid on receipt of price by

ORANGE JUDD COMPANY, 245 BROADWAY, NEW YORK.

SUPERIOR STANDARD WORKS.

Published by ORANGE JUDD COMPANY.

THE HORSE.

FRANK FORESTER'S HORSE OF AMERICA.

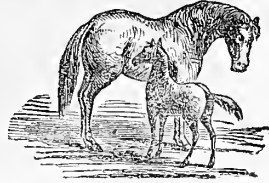

By HENRY WM. HERBERT.

Revised, corrected, enlarged, and continued to 1871,

By S. D. and B. G. BRUCE.

Always an ACKNOWLEDGED STANDARD, and now the most COMPLETE and AUTHENTIC Work on the HORSE. With steel-engraved portraits of Thirty of the most famous

REPRESENTATIVE HORSES, including pedigrees, histories, and performances.

Two superb royal octavo volumes of upward of 1300 pages.

Post-Paid, Ten Dollars.



WALLACE'S

American Trotting Register.

CONTAINING ALL THAT IS KNOWN OF THE

PEDIGREES OF TROTTING HORSES,

their ancestors and descendants, with a record of

All published performances in which a mile was trotted or paced in 2.40 or less,

from the earliest dates until the close of 1868, and a full record of the performances of 1869 and 1870.

Giving complete Summaries of over 6,000 Contests.

With an INTRODUCTORY ESSAY on the true origin of the American Trotter. And a set of Rules for the government of all trials of speed. By J. H. WALLACE, compiler of Wallace's American Stud-Book. Royal octavo.

Post-paid, Ten Dollars.

WALLACE'S AMERICAN STUD-BOOK.

VOL. ONE. BEING A COMPILATION OF THE PEDIGREES OF AMERICAN AND IMPORTED BLOOD HORSES,

from the earliest records, with an APPENDIX of all named animals without extended Pedigrees prior to the year 1840. And a SUPPLEMENT, containing a history of all Horses and Mares that have trotted in public from the earliest trotting races until the close of 1866. By J. H. WALLACE. Royal octavo of over 1000 pages, elegantly bound in extra cloth, beveled boards, and splendidly illustrated.

Post-paid, Ten Dollars.

Horse Portraiture. — BREEDING,

REARING, AND TRAINING TROTTERS. Preparations for Races, Management in the Stable, on the Track, Horse Life, etc. By JOSEPH CAIRN SIMPSON. Pos. octavo. Post-paid, \$3.00.

FIELD SPORTS.



Frank Forester's Field Sports.

Embracing the Game of North America, Upland Shooting, Bay Shooting, Wild Sporting of the Wilderness, Forest, Prairie, and Mountain Sports, Bear Hunting, Turkey Shooting, etc. 13th edition, revised and illustrated. Two post octavo volumes. Post-paid, \$6.00.

Frank Forester's Fish and Fishing.

100 engravings. Embracing a full illustrated description of the Game Fish of North America; Trout and Salmon Fishing; Shoal Water and Deep Sea Fishing; Lake and River Fishing; Trolling, Fly Fishing, etc. 12th edition. One post octavo volume. Post-paid, \$3.50.

Frank Forester's Complete Manual.

For Young Sportsmen, of Fowling, Fishing, and Field Sports. With directions for handling the Gun, the Rifle, and the Rod. Art of Shooting on the Wing. The Breaking, Management, and Hunting of the Dog. The varieties and habits of Game. River, Lake, and Sea Fishing. Post octavo. Post-paid, \$3.00.

Frank Forester's American Game in its SEASONS, Fully Illustrated and Described. New edition, post-paid, \$3.00.

The Dog.

By Dinks, Mayhew & Hutchinson. Compiled and edited by Frank Forester. Containing full instructions in all that relates to the Breeding, Rearing, Breaking, Kenneling, and Conditioning of Dogs, with valuable recipes for the treatment of all diseases. Illustrated. Post octavo. Post-paid, \$3.00.

The Dead Shot:

Or, Sportsman's Complete Guide; a Treatise on the use of the Gun, with Rudimentary and Finishing Lessons in the Art of Shooting Game of all kinds. By Marksman. Post-paid, \$1.75.

The Crack Shot:

Or, Young Rifleman's Complete Guide; being a Treatise on the use of the Rifle, with Lessons, including a full description of the latest improved breech-loading weapons; rules and regulations for Target Practice, and directions for Hunting Game. By Edward C. Barber. Post-paid, \$1.75.

Gun, Rod, and Saddle.

Nearly fifty practical articles on subjects connected with Fishing, Shooting, Racing, Trotting, etc. Post-paid, \$1.

Practical Trout Culture.

By J. H. Slaek, M. D., Commissioner of Fisheries, New Jersey. Fully illustrated and describing thoroughly all that is requisite to successful Trout Culture. Post-paid, \$1.50.

AGRICULTURE.

Woodward's Graperies and Horticultural

BUILDINGS. Designs and Plans of Hot-beds, Cold Pits, Propagating Houses, Forcing Houses, Hot and Cold Graperies, Greenhouses, Conservatories, Orchard Houses, etc., with the various modes of Ventilating and Heating. Post-paid, \$1.50.

Jacques' Manual of the Garden, Farm,

AND BARN-YARD. Embracing the Cultivation of Vegetables, Fruit, Flowers, all Field Crops, Details of Farm Work and Rearing Domestic Animals. New and Revised Edition. One volume. Post-paid, \$1.75.

Young Farmer's Manual.

Vol. I. The Farm and the Workshop, with Practical Directions for laying out a Farm, Erecting Buildings, Fences, Farm Gates, Selecting good Farm and Shop Tools, and performing Farm Operations. Fully illustrated. Post-paid, \$1.75.

Young Farmer's Manual.

Vol. II. How to Make Farming Pay, with full Details of Farm Management, Character of Soils, Plowing, Management of Grass Lands, Manures, Farm Implements, Stock, Drainage, Planting, Harvesting, etc. Illustrated. Post-paid, \$1.75.

Husmann's Grapes and Wine.

The Cultivation of the Native Grape and Manufacture of American Wine. By Geo. Husmann, of Missouri. Post-paid, \$1.50.

Elliott's Lawn and Shade Trees.

For Planting Parks, Gardens, Cemeteries, Private Grounds, and Avenues. Fully illustrated and described. Post-paid, \$1.50.

Fuller's Forest Tree Culturist.

The Cultivation of Forest Trees for Shade, for Shelter, for Fuel, for Timber, and for Profit. Illustrated. Post-paid, \$1.50.

ORANGE JUDD COMPANY, 245 Broadway, N. Y.

CRANDALL'S GREAT SHOW.—THE ACROBATS.

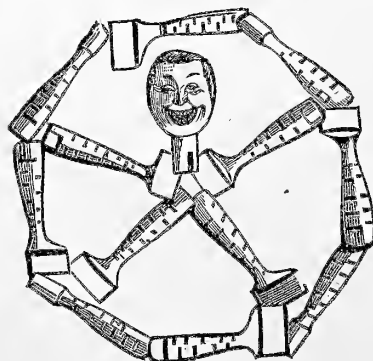
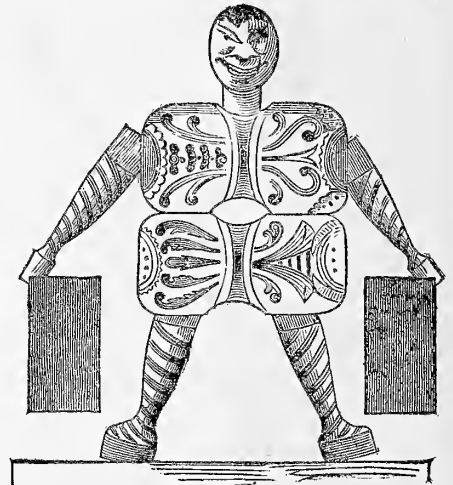
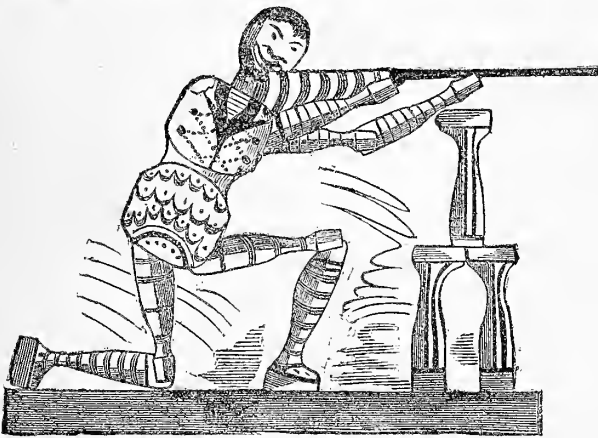
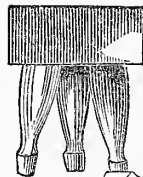
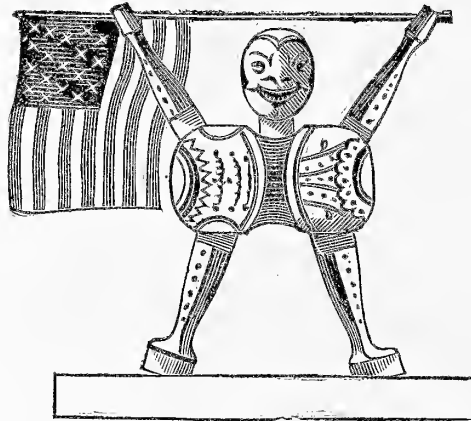
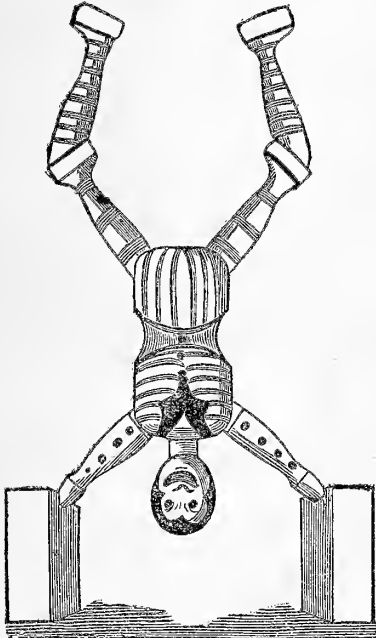
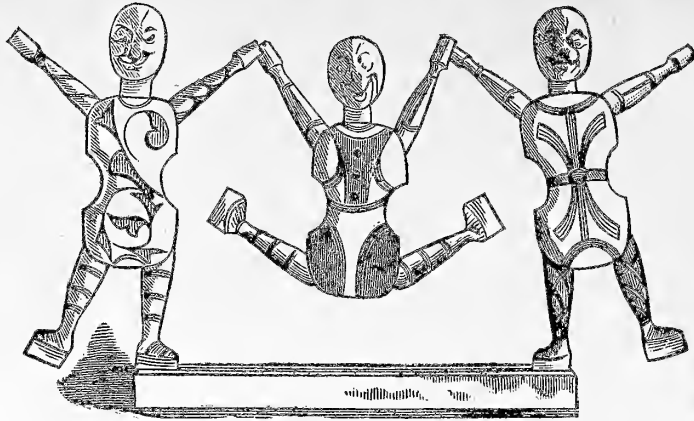

CRANDALL'S GREAT SHOW.—THE ACROBATS.

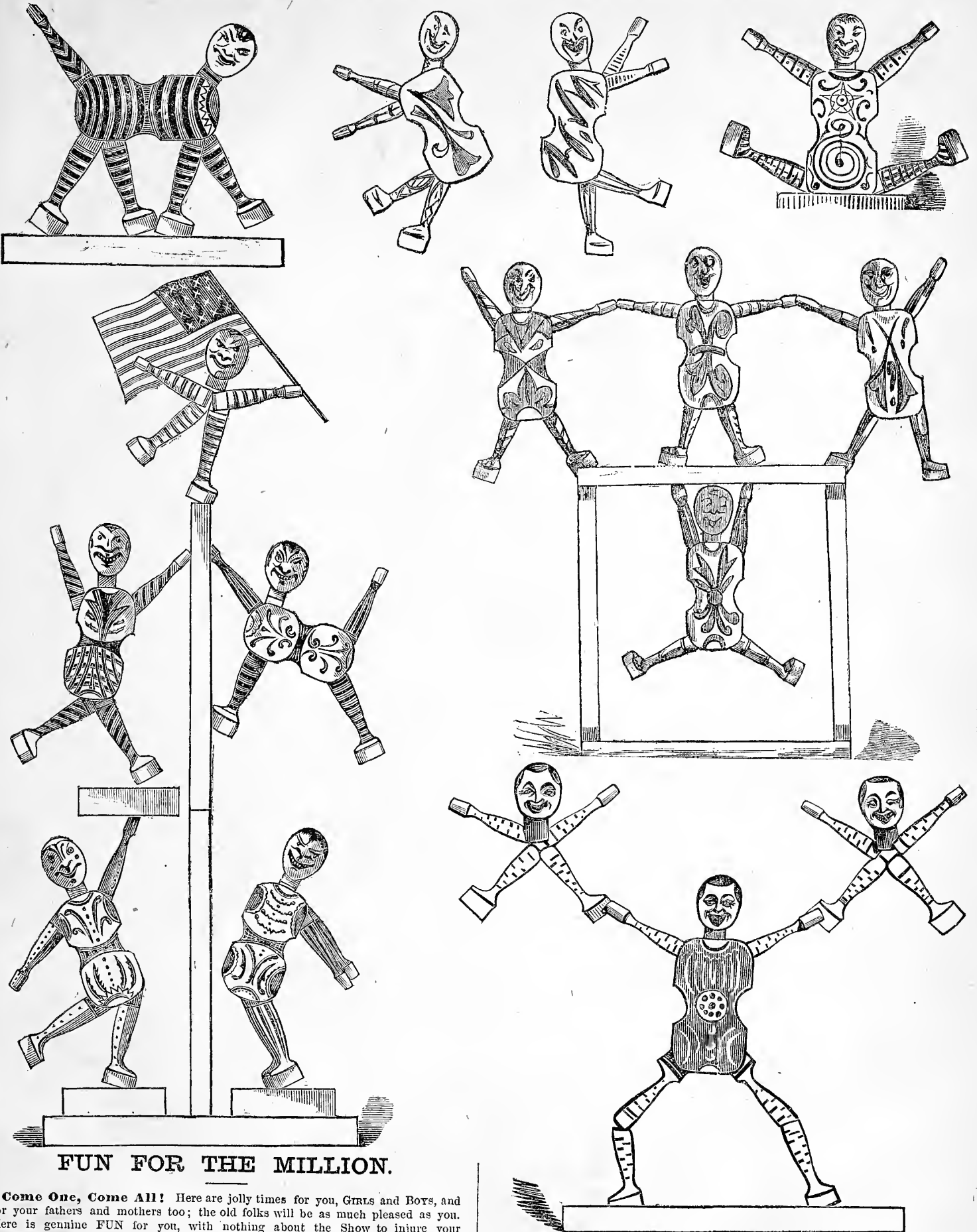

FUN FOR THE MILLION.

Come One, Come All! Here are jolly times for you, Girls and Boys, and for your fathers and mothers too; the old folks will be as much pleased as you. Here is genuine FUN for you, with nothing about the Show to injure your morals, but on the contrary, a great deal to develop your constructive or mechanical talents. These new ACROBATS of Mr. Crandall are the most wonderful toys we have ever seen. If you carefully examine each of the figures on these two pages, you will see that there are only SEVEN different pieces. A box of these ACROBATS contains four bodies, four heads, eight arms, eight legs, one flag, and six pieces of wood, or thirty-one pieces in all, and yet from these few elements you can not only make pictures similar to those before you, but many thousands of others. The pieces are variously colored, which can not be shown in our ink engravings. They are

so grooved and jointed and fitted, that they fasten strongly together in all conceivable positions. These amusing new toys are creating a furore among all the children (and old folks too) who have succeeded in getting hold of them. Every day's supply received at 245 Broadway, has "gone off like hot cakes," and correspondents are inquiring for them, their price, etc. They will soon be on sale by the toy dealers generally. The Orange Judd Company are selling them as fast as received at \$1 a box, delivered at 245 Broadway, New York, but if to be sent anywhere out of the city, the cost of carriage by express or otherwise must be added to the \$1 a box.

DON'T FAIL TO HAVE A LIBRARY. GOOD BOOKS For Farmers' Libraries.

In response to a request made of one whose thorough and practical knowledge on all matters pertaining to the Farm, Garden, and Household is so fully conceded that his opinions could not fail to secure attention and command respect were we permitted to give his name, we have received the following as his judgment concerning some of the works on our Catalogue of Books for Farmers.

Any of these Books will be forwarded, post-paid, to any address in the United States or Territories, on receipt of the price, by Orange Judd Company, 245 Broadway, New York.

For a Farmer's Library.

How Crops Grow,

(price \$2.00), and

How Crops Feed,

(price \$2.00.)

By PROF. SAM'L W. JOHNSON.

If I could have but two books in such a library it would be these, as I consider them the most important contributions to agricultural literature of modern times. They contain all of vegetable physiology and agricultural chemistry that any except special students need, and nowhere is there so much of agriculture condensed in so small a space. As works of reference they are indispensable.

Most farming operations are accomplished by force, applied through implements and machines, and a farmer should understand mechanics, at least sufficiently to apply force most economically. In this work the fundamental principles are clearly taught, and their application illustrated.

Farm Implements and Machinery.

By JOHN J. THOMAS.

Price \$1.50.

The New American Farm Book.

By R. L. and L. F. ALLEN.

Price \$2.50.

This is the best American work upon general farm management. It treats of the leading crops, buildings, draining, etc., and includes sufficient about animals of different kinds to meet the wants of most farmers.

American Weeds and Useful Plants.

By DR. WM. DARLINGTON.

Price \$1.75.

For the farmer who wishes to know something about the weeds upon his farm, as well as useful cultivated and wild plants, this will answer better than a general treatise on botany.

Country and Suburban Homes.

By D. T. ATWOOD.

Price \$1.50.

Such a library should have some work on domestic architecture. Most works upon the subject are costly on account of the designs. This is one of the best works, at a moderate price, and contains, with other matter, the method of building with concrete.

The Fruit Garden.

By P. BARRY. Price \$2.50.

After the farm crops, fruit is of the most importance. No work covers the whole subject so completely as this.

Gardening for Profit.

By PETER HENDERSON.

Price \$1.50.

Farms near cities often make more from garden crops than from farm crops. This is the best work on market gardening, and will serve for the family garden also.

Gardening for the South.

By WM. N. WHITE.

Price \$2.00.

An excellent garden book, and in the libraries for Southern farmers might be substituted for Henderson's, but it would be well to have both.

The New Book of Flowers.

By JOSEPH BRECK.

Price \$1.75.

I do not know of any book upon out-door flower gardening that on the whole is so good as this. Its teachings are sound, and style pleasing.

Mysteries of Bee-Keeping.

By M. QUINBY. Price \$1.50.

Practical Poultry-Keeper.

By L. WRIGHT. Price \$2.00.

The Pig.

By JOSEPH HARRIS.

Price \$1.50.

Draining for Profit.

By GEO. E. WARING, JR.

Price \$1.50.

Dairy Husbandry.

By X. A. WILLARD.

Price \$3.00.

Bees, Poultry, and Pigs are often made subjects of especial care by small farmers, and separate treatises on these are more likely to be asked for in a library like this than those upon the larger animals. Each of these is the best in its line.

So in farm operations, those of Draining and Dairying, especially the factory system, are not likely to be treated sufficiently in detail in general works.

As all the other works are matters of fact, it may be well to have a little pleasantries. This conveys much sound teaching on rural economy in a quaint style, and it is sometimes policy to sugar-coat your pill.

Tim Bunker Papers.

Price \$1.50.

Books for a Larger Library.

Besides all the works in the foregoing list, I would add the following:

- American Cattle.** L. F. ALLEN. \$2.50.
- Randall's Sheep Husbandry.** \$1.50.
- Hints to Horse Keepers.** H. W. HERBERT. \$1.75.
- American Cattle Doctor.** G. H. DADD. \$1.50.
- Insects Injurious to Vegetation.** DR. HARRIS. \$4.00.
- Fruits and Fruit Trees of America.** DOWNING. \$5.00.
- Cranberry Culture.** J. J. WHITE. \$1.25.
- Grape Culturist.** A. S. FULLER. \$1.50. (For the West would substitute Husmann's Grapes and Wine. \$1.50.)
- Grasses and Forage Plants.** C. L. FLINT. \$2.50.
- Forest Trees.** ARTHUR BRYANT. \$1.50.
- Landscape Gardening.** KEMP. \$2.50.
- Hops.** 40 cts. **Flax.** 50 cts. **Tobacco.** 25 cts. **Onion.** 20 cts. Essays.
- Bousingault's Rural Economy.** \$1.60.
- Play and Profit in My Garden.** ROE. \$1.50.
- Window Gardening.** WILLIAMS. \$1.50.

Books for a Still Larger Library.

In addition to those mentioned in the other two lists, I would name the following.

- Animals and Plants under Domestication.** 2 vols. CHAS. DARWIN. \$6. (This not suggested for its doctrine, but as a useful work of reference.)
- Hussey's National Cottage Architecture.** \$6.
- Landscape Gardening.** DOWNING. \$6.50.
- The Vegetables of America.** F. BURR. \$5.
- The Book of Evergreens.** J. HOOPES. \$3.
- Trout Culture.** DR. SLACK. \$1.50.
- Farm Gardening & Seed Growing.** BRILL. \$1.
- The Dog.** DINKS, MAYHEW & HUTCHINSON. \$3.
- Young Sportsman's Manual.** FORRESTER. \$3.
- Hunter and Trapper.** H. THRASHER. \$1.
- The Market Assistant.** DEVOE. \$2.50.
- Hedges and Evergreens.** WARDER. \$1.50.
- Pear Culture.** P. T. QUINN. \$1.
- Money in the Garden.** QUINN. \$1.50.
- How Plants Grow.** GRAY. \$1.25.
- How Plants Behave.** GRAY. 75 cts.
- Illustrated Horse Doctor.** MAYHEW. \$3.
- Peach Culture.** FULTON. \$1.50.
- Barns, Out-Buildings & Fences.** HARNEY. \$6.
- Cottages and Farm Houses.** WOODWARD. \$1.50.
- Country Homes.** WOODWARD. \$1.50.

A Man of Honor.

By GEORGE CARY EGGLESTON.

Finely Illustrated.

The publishers take pleasure in commending this as one of the most charming stories that has been presented to the American people. Mr. Eggleston has given to it, with rare fidelity, the local coloring of the part of the country where its scenes are laid. It is a realistic story of life in the Old Dominion. Its people are ladies and gentlemen. Robert Pagebrook, the "Man of Honor," is every inch a man, and his sayings and doings at once attract and hold the reader's attentive interest. It is a love-story, too, and has the merit, which is not as common as it might be nowadays, of ending to the reader's entire satisfaction.

NOTICES BY THE PRESS.

A capital picture of Life in Old Virginia before the war is to be found in Mr. George Cary Eggleston's "A Man of Honor." Virginian hospitality, Virginian consenship, Virginian housekeeping, are portrayed in accurate and attractive colors. It is a life which the author has himself known and loved, and he writes of it with a warmth that comes from the heart.—*N. Y. Evening Post.*

Really readable in the most refreshing sense of the term—a story of the most amusing and attractive interest.—*St. Louis Times.*

It is written in an off-hand manner, and is bright and amusing.—*Worcester, (Mass.) Spy.*

With Virginian life as a specialty, Mr. Eggleston has drawn a simple, straightforward, truthful, and withal, artistic picture of Southern society. It is sketchy, perhaps too much so, but the sketches are all vigorous and show the hand of a practiced artist. In forming the characters of his book it is evident that Mr. Eggleston has drawn oftener on his memory than on his imagination; that he has lived among the people whom he describes, has heard them talk, and seen them under all the moods of ordinary life.—*Boston Daily Advertiser.*

CONTENTS.

- Chapter 1. Mr. Pagebrook gets up and calls an Ancient Lawgiver.—2. Mr. Pagebrook is Invited to Breakfast.—3. Mr. Pagebrook Eats his Breakfast.—4. Mr. Pagebrook Learns Something about the Customs of the Country.—5. Mr. Pagebrook Makes some Acquaintances.—6. Mr. Pagebrook Makes a Good Impression.—7. Mr. Pagebrook Learns Several Things.—8. Miss Sudic Makes an Apt Quotation.—9. Mr. Pagebrook Meets an Acquaintance.—10. Chiefly Concerning "Foggy."—11. Mr. Pagebrook Rides.—12. Mr. Pagebrook Dines with his Cousin Sarah Ann.—13. Concerning the Rivulets of Blue Blood.—14. Mr. Pagebrook Manages to be in at the Death.—15. Some very Unreasonable Conduct.—16. What Occurred Next Morning.—17. In which Mr. Pagebrook Bids his Friends Good-by.—18. Mr. Pagebrook Goes to Work.—19. A Short Chapter, not very Interesting, perhaps, but of some Importance in the Story, as the Reader will probably Discover after awhile.—20. Cousin Sarah Ann Takes Robert's Part.—21. Miss Barksdale Expresses some Opinions.—22. Mr. Sharp Does his Duty.—23. Mr. Pagebrook Takes a Lesson in the Law.—24. Mr. Pagebrook Cnts Himself Loose from the Past and Plans a Future.—25. In which Miss Sudic Acts very Unreasonably.—26. In which Miss Sudic adopts the Socratic Method.—27. Mr. Pagebrook Accepts an Invitation to Lunch and Another Invitation.—28. Major Pagebrook Asserts Himself.—29. Mr. Barksdale the Younger goes upon a Journey.—30. The Younger Mr. Barksdale Asks to be Put upon his Oath.—31. Mr. William Barksdale Explains.—32. Which is also the Last.

ILLUSTRATIONS.—By M. WOOLF.

"Now I've Got You" (Frontispiece).—Mr. Robert Pagebrook was "Blue."—"I Fall at Once into a Chronic State of Washing up Things."—"Foggy."—Cousin Sarah Ann.—The Rivulets of Blue Blood.—Miss Sudic Declares Herself "so Glad."—"Let Him Serve it at Once, Then."—"Very Well, Then."—"I'm as Proud and as Glad as a Boy with Red Morocco Tops to his Boots."

PRICE, POST-PAID \$1.25

ORANGE JUDD COMPANY,
245 BROADWAY, NEW YORK.

ORANGE JUDD COMPANY,
245 BROADWAY NEW YORK.

THE HOOSIER SCHOOL-MASTER.

By EDWARD EGGLESTON.

Finely Illustrated, with 12 Full-Page Engravings, and Numerous Other Cuts.

NOTICES BY THE PRESS.

It is full of quaint humor, a tender pathos, and vivid descriptions.—*New York Standard*.

The "events" are stirring and dramatic, and the style is quiet, impersonal, and almost epigrammatic in its ability to lay bare an entire situation or character in a sentence or phrase.—*Brooklyn Daily Eagle*.

It is at once quaint and truthful, and illustrated as it is by masterly cuts, it should be one of the most popular books.—*Christian Standard* (Cincinnati).

For realistic conception and life-like delineation of character, it is not excelled by any American story.—*Methodist*.

Some passages in it, for life-like delineation and the simple, artless beauty which constitute the highest perfection of story-writing, are equal to some of the very best passages in Dickens.—*Religious Telescope*.

PRICE, POST-PAID.....\$1.25.

The End of the World.

A LOVE STORY.

By EDWARD EGGLESTON,
Author of "The Hoosier School-Master."

WITH

Thirty-two Fine Illustrations.

NOTICES BY THE PRESS.

The personages who figure in this story are, with one exception, country people—such men and women as Wordsworth loved to study. It is not every man, whatever may be his talents, that can safely enter this sphere of literary labor. To be successful in it, he must possess exceptional qualities; but for those who know how to find it, here there is gold of the purest, richest kind. In such a work, however, there is no convenient place where mediocrity can rest; there is nothing but absolute failure or absolute success. And Mr. Eggleston has succeeded. His power lies in the delineation of character. The plot is ingenious and natural, the incidents are managed with great skill, and there are many descriptive passages of singular force and beauty. But the strongest impression left on the reader's mind as he closes the volume is that he has been in the company of very interesting men and women, and has made a number of new and valuable acquaintances.—*The Albion*, New York.

Price, Post-paid, \$1.50.

The Mystery

OF

Metropolisville,

By EDWARD EGGLESTON,

Author of "The Hoosier School-Master," "The End of the World," etc.

FINELY ILLUSTRATED.

CONTENTS.

Preface.—Words Beforehand. Chapter 1. The Autocrat of the Stage-Coach.—2. The Sod Tavern.—3. Land and Love.—4. Albert and Katy.—5. Corner-Lots.—6. Little Katy's Lover.—7. Catching and Getting Caught.—8. Isabel Marlay.—9. Lovers and Lovers.—10. Plausaby, Esq., takes a Fatherly Interest.—11. About Several Things.—12. An Adventure.—13. A Shelter.—14. The Inhabitant.—15. An Episode.—16. The Return.—17. Sawney and his Old Love.—18. A Collision.—19. Standing Guard in Vain.—20. Sawney and Westcott.—21. Rowing.—22. Sailing.—23. Sinking.—24. Dragging.—25. Afterwards.—26. The Mystery.—27. The Arrest.—28. The Tempter.—29. The Trial.—30. The Penitentiary.—31. Mr. Lurton.—32. A Confession.—33. Death.—34. Mr. Lurton's Courtship.—35. Unbarred.—36. Isabel.—37. The Last.—Words Afterwards.

ILLUSTRATIONS.—By FRANK BEARD.

His Unselfish Love found a Melancholy Recompense.—The Superior Being.—Mr. Minorkey and the Fat Gentleman.—Plausaby sells Lots.—"By George! He! he! he!"—Mrs. Plausaby.—The Inhabitant.—A Finch of Snuff.—Mrs. Ferret.—One Savage Blow full in the Face.—"What on Airth's the Matter?"—The Editor of "The Windmill."—"Git up and Foller!"

Price Postpaid - - - - \$1 50

Either of the above books sent post-paid on receipt of price, by the

ORANGE JUDD COMPANY,
245 BROADWAY, NEW YORK.

WHOLESALE PRICE-LIST. CRANDALL'S IMPROVED BUILDING - BLOCKS FOR CHILDREN.



BEAUTIFUL,
AMUSING,
INSTRUCTIVE.

CRANDALL'S Building - Blocks.

PRICE PER DOZEN BOXES.

- No. 1, \$12.00 (3 Dozen Boxes in a Case).
- No. 3, \$ 6.00 (6 Dozen Boxes in a Case).
- No. 4, \$ 6.00 (6 Dozen Boxes in a Case).

CRANDALL'S Masquerade - Blocks.

Price per Dozen Boxes \$6.00 (6 Dozen Boxes in a Case).

CRANDALL'S Expression - Blocks.

Price per Dozen Boxes, \$3.00 (12 Dozen Boxes in a Case).

Crandall's Acrobats.

Price per Dozen Boxes, \$8.00 (6 Dozen Boxes in a Case).

CRANDALL'S Alphabet-Blocks,

Red, White, and Blue.

Price per Dozen Boxes, \$6.00 (6 Dozen Boxes in a Case).

Orders from the trade will be supplied on liberal terms.

MANUFACTURED BY
C. M. CRANDALL & CO.

ORANGE JUDD COMPANY,
Sole Agents,
245 BROADWAY, NEW YORK.

"UP FOR REPAIRS,"

A Beautiful, New Picture for Every Subscriber to the

American Agriculturist

FOR 1874.

An exquisite Oil Painting by the celebrated American Painter, Mr. B. F. Reinhart, executed expressly for the *American Agriculturist* and entitled

"UP FOR REPAIRS,"

has been most successfully reproduced in Chromo by the well-known firm of Bencke & Scott. It is a picture of a scene in childhood, which many will recognize as what they have themselves witnessed or been actors in, and can not fail to please both old and young.

The Publishers will give this beautiful Chromo

To Every Subscriber

to this paper for the year 1874 received after this date, as detailed below. It is ready for immediate delivery at 245 Broadway, Free of Charge.

If to go by mail, 10 cents must be sent to cover cost of packing and postage. For 25 cents it will be Mounted, Varnished, Packed, and sent Post-paid.

N. B.—The Chromo will be delivered:

- At the Office, Unmounted, Free.
- " " Mounted, 15 cents extra.
- Sent by Mail, Unmounted, 10 cents extra.
- " " Mounted, 25 cents extra.

We advise all to have them mounted before leaving the office, as in the large quantities we put up we are able to mount them for a quarter of the cost or doing it singly, and better than it can usually be done elsewhere.

The picture is designed for every subscriber upon the terms stated above, which please read carefully; and on these terms all are alike entitled to it, whether their names come singly at \$1.50 each, or in Clubs of Four for \$5, or Clubs of Ten at \$1.20 each, or in Clubs of Twenty or more at \$1 each. Subscribers in Premium Clubs will also thus be entitled to it.

N. B.—A few of the beautiful pictures entitled "MISCHIEF BREWING," which have been given to so large a number of subscribers, are still in stock, and, while any remain, subscribers to the *American Agriculturist* can have their choice between this and the new Chromo "UP FOR REPAIRS"; but the choice must be named at time of subscribing. ORANGE JUDD COMPANY,
245 BROADWAY, NEW YORK.

Window Gardening.

By HENRY T. WILLIAMS,

EDITOR OF THE HORTICULTURIST, AND HORTICULTURAL EDITOR OF THE NEW YORK INDEPENDENT.

FINELY ILLUSTRATED.

There can be no more attractive ornaments about the house than beautiful flowers, and Mr. Williams's book tells exactly how they may be arranged, and what flowers to plant. It is seldom that a book is published on such subjects containing so much practical information.

—The World (New York).

CONTENTS:

- Chap. 1.—Window Gardening—Its Pleasures—Increase in Popular Taste—Refraining Influences.
- Chap. 2.—Location and Designs for Window Gardens.
- Chap. 3.—General Management of Window Gardens.
- Chap. 4.—Special Care of Window Gardens.
- Chap. 5.—Insects, and how to Kill them.
- Chap. 6.—Propagation from Seeds, Cuttings, etc.
- Chap. 7.—Propagating Boxes, Heating Cases, etc.
- Chap. 8.—Window Pots, Boxes, Plant Stands.
- Chap. 9.—Conservatories and Greenhouses.
- Chap. 10.—Hanging Baskets.
- Chap. 11.—The Ivy for Decorative Purposes.
- Chap. 12.—Climbing Vines, Balcony Gardening.
- Chap. 13.—Fibbs.
- Chap. 14.—Ferneries, Warden Cases, Fern Decorations.
- Chap. 15.—The Camellia.
- Chap. 16.—The Rose.
- Chap. 17.—The Fuchsia, Myrtle.
- Chap. 18.—The Heliotrope.
- Chap. 19.—The Geranium.
- Chap. 20.—The Oleander, Bouvardia.
- Chap. 21.—Verbenas, Petunias, etc.
- Chap. 22.—The Mignonette, Cinerarias.
- Chap. 23.—Carnations.
- Chap. 24.—Alpine Plants.
- Chap. 25.—Miscellaneous Plants.
- Chap. 26.—Parlor Decorations.

Price, post-paid, \$1.50

ORANGE JUDD COMPANY,
245 BROADWAY, NEW YORK.

GREAT DEDUCTION.
TEAS and COFFEES
 At Wholesale Prices.
 Increased Facilities to Club Organizers.
 Send for New Price-List.
THE GREAT AMERICAN TEA COMPANY,
 (P. O. Box 5643.) 31 and 33 Vesey St., New York.

WOOD, TABER & MORSE,
 Eaton, Madison Co., N. Y.
 MANUFACTURERS OF
Steam-Engines,
 Portable, Stationary, and
 Agricultural.
 Hundreds in use in Shops, Print-
 ing Rooms, Mills, Mines, and on
 Farms and Plantations for Grain
 Threshing, Food Cooking for
 Stock, Cotton Ginning, Sawing, etc.
 Circulars sent on application.

STANDARD PEARS.
 An immense number of splendid trees. Several blocks of
 different ages. All ready for Fall trade. An unbroken
 block of 300,000, unequalled in this country.
 Also, a general Nursery Stock, very fine. Come and see.
 Send for Price List.
 NICHOLAS & NEWSON, Geneva, N. Y.

FRUIT AND TREES!
ORNAMENTAL TREES!
 LARGE STOCK. LOW RATES.
 STANDARD PEAR-TREES A SPECIALTY.
 AGENTS WANTED. Address
E. MOODY & SONS, Lockport, N. Y.
 NIAGARA NURSERIES, established 1839.

THE PATENT
ARION
PIANO-FORTE
*Excels all others in Tone and Durability,
 and in Elegance of Finish they
 are Unsurpassed.*
 These Pianos are used exclusively in the New York Con-
 servatory of Music, and are recommended by the Profession
 and the Press throughout the United States.
 Before purchasing, write for Illustrated Pamphlet, and
 mention the *Agriculturist*.
ARION PIANO-FORTE CO.,
 No. 5 East 14th Street, New York City.

NEW
DIPLOMAS
 FOR
AGRICULTURAL SOCIETIES
 Specimens supplied by
 The Major & Knapp Engraving, Mfg. and Lithographing Co.
 56 & 58 Park Place, N. Y.

NIAGARA FIRE INSURANCE
COMPANY,
 201 Broadway, N. Y.
 Capital Stock.....\$500,000
 Cash value of Assets.....\$1,308,324
 Total Liabilities.....\$2,302,324
 Net Assets.....\$1,235,923
 Dwellings and Farm Risks a specialty at all our Agencies.
 HENRY A. HOWE, President.
 P. NOTMAN, V. P. and Sec'y.

The Patron's Hand-Book.—Pro-
 nounced by Masters and Secretaries of State Granges to
 be invaluable. Circular, giving contents, free. Mailed to
 any address, for 25 cents. Address, J. K. HUDSON,
 Editor and Proprietor Kansas Farmer, Topeka, Kansas.

PHILADELPHIA, June 11, 1874.
 N. GUILBERT, Gwynedd, Pa.—Enclosed is sample of wool
 of a yearling ewe, bred from the ewe Cotswold that I ordered
 from you for Mr. Keller, at Akron, Pa.; the wool of the
 yearling weighed 16½ lbs., and speaks very well for your
 stock. He intends having it advertised in the Lancaster
 newspapers. He sold all his other sheep.
 Yours, etc., A. H. FRASER, No. 415 S. Second St.
 Always on hand and for sale, Cotswold Sheep, Southdowns,
 Blooded Live Stock, Horses, Cows, Calves, Swine, Geese,
 Ducks, Turkeys, Fancy Fowls, Peacocks, Doves, Maltese
 Cats, Rabbits, Guinea Pigs, White Mice, Deer, Swan, Pigeons,
 etc. A noble pair of thoroughbred Mastiffs, and an elegant
 English Greyhound Dog. Wanted—Deer, Swan, and Wild
 Geese. N. GUILBERT, Evergreen Farm, Gwynedd, Pa.

A M A G R I . **P A T . D E P T .**

TO ALL TO WHOM THESE PRESENTS SHALL COME
 Wherein Only the Name of the Invention is
 mentioned, the Office of the
 Commissioner of Patents, Washington, D. C.

IMPORTANT TO INVENTORS.
American Agriculturist
PATENT DEPARTMENT

In compliance with the request of numerous inven-
 tors, we have organized a
PATENT DEPARTMENT
 in connection with this office for the transaction of all
 business connected with
Securing Patents
 in the United States and foreign countries.
 The character for

Reliability
 which has been maintained by the AMERICAN AGRICUL-
 TURIST for more than thirty years will be carefully
 guarded in this as in other departments.

All Inventors
 desirous of procuring patents at moderate cost are in-
 vited to forward (express prepaid) a model of their in-
 vention, with a brief description of its working. The
 model should not exceed one cubic foot in dimension.
 Upon receipt of model an opinion as to patentability
 will be given free of charge.

Preliminary Examination
 at the Patent Office, to determine patentability,
 will be promptly made for a fee of \$5.
Litigation of Patents.

The services of the best counsel have been
 secured to prosecute or protect before the
 U. S. Courts and the Patent Office the claims
 of those intrusting their business to this
 agency.
 Specifications, drawings, engravings, models,
 and all other appliances furnished at
 moderate prices.

In all dealings with this Department in-
 ventors may depend upon promptness, fidelity
 to their interests, and the best services
 which can be rendered by thorough experts.
 For full particulars, address
AMERICAN AGRICULTURIST
PATENT DEPARTMENT
ORANGE JUDD COMPANY,
 245 Broadway, New York.

Hope Seat Springs.
 For Farm Wagons, Trucks, Carts, Hay Tedders, Wheel Horse-Rakes, etc. The best and Easiest Riding Spring ever invented. The seat can be moved to any part of the wagon, or can be removed at will. The spring is entirely under the seat, and out of the way. Every spring fully warranted. After using them six months, if not found as represented, can be returned, and money will be refunded. Every Farmer should have a pair. Price \$4.50. Send for circular.
BENJ. F. WELLS, Sole Agent,
 47 Dey St., New York.

JOHN ANDROSS.
 BY
REBECCA HARDING DAVIS,
 Author of "Life in the Iron Mills," "Dallas Galbraith," etc., etc.
ILLUSTRATED.
NOTICES BY THE PRESS.

The story is of intense interest, and holds the reader from its commencement to its close, and gives much food for thought regarding the workings of political rings and government frauds in our large cities.—*Post*, Salem, Mass.
 The characters and their work are strongly but no doubt truthfully drawn. Aside from its literary merit, the book deserves credit for calling attention to a crying shame of our time.—*Christian Advocate*, Pittsburgh, Pa.
 It will at once enchain the attention of the reader, and prove vigorously and skillfully written, by this among the foremost novel writers of America.—*Commonwealth*, Boston, Mass.

Of a story of Mrs. Davis it is hardly necessary to say that it holds the reader's absorbed attention from beginning to end. Though the interest of the plot is very considerable, it is subordinate to the higher interest of the description and development of character. There is a great deal of very life-like painting of people and manners.—*Christian Union*, New York.
 The characters are well drawn, the incidents are full of interest, and the plot sustained with consistency and power.—*Daily Spy*, Worcester; Mass.

We are constantly struck with the out-cropping of the one golden thread that holds all her writings together, and never fails to shine through the web of whatever plot she weaves about it—that singleness of point and moral more characteristic of her writings than of any other we know of, and which is, broadly stated, a self-sacrificing devotion to duty.—*Daily Standard*, Bridgeport, Ct.
 Her hero is a man entangled by the great Ring of Pennsylvania, who is sent by this corporation to the State Senate with a hold of criminality to keep him in hand, who even then attempts to break loose and join the party of honesty, but is at the crisis brought in check again by the Ring, with the still more potent motive of love. . . . The plot is very well wrought, and the denouement is powerfully conceived and managed.—*New York Evening Mail*.

Price, Post-paid, \$1.50.
ORANGE JUDD COMPANY,
 245 BROADWAY, NEW YORK.

Agricultural Chemical Analysis.
 After E. Wolff, Fresenius, Krooker, and Others.
 Edited by **G. C. CALDWELL,**
 OF CORNELL UNIVERSITY.
PRICE, POST-PAID, \$2.00.

In this work Professor Caldwell has brought together the processes of analysis which apply especially to soils, fertilizers, animals and plants, and their products. He has tested the methods of the best foreign authorities, and presented them in a compact hand-book. Such a work has long been needed by all who teach agricultural chemistry, and by analytical chemists generally. Professor Caldwell modestly calls himself the editor, but his book shows that he has not contented himself with editing the works of others, but has given much of his own experience.
ORANGE JUDD COMPANY,
 245 BROADWAY, NEW YORK.

WANTED.—The United States Life Insurance Company is now re-organizing its Agency Department, and is prepared to negotiate with gentlemen of business ability to act as Agents. Previous connection with the business is not considered necessary.
 Apply at the Home Office, 261 Broadway, New York. **JOHN E. DEWITT, President.**

Standard Architectural Books for Carpenters and Builders.



Hussey's National Cottage Architecture; or, Homes for Every One.—With Designs, Plans, Details, Specifications, and Cost; with Working Scale. Drawings complete, so that Houses may be built direct from the book. Adapted to the popular demand for practical, handsome, and economical homes. Royal Quarto. Six Dollars, post-paid.

Atwood's Country and Suburban Houses.—Illustrated with about 150 engravings. Hints and Suggestions as to the General Principles of House-building, Style, Cost, Location, etc. Post-paid, \$1.50.

Monckton's National Stair-Builder.—Is a complete work on Stair-Building and Hand-Railing. Fully explained and illustrated by large scale diagrams, in two colors, with designs for Staircases, Newels, Balusters, and Hand-Rails. Royal Quarto. Post-paid, \$6.00

Monckton's National Carpenter and Joiner.—A complete work, covering the whole science of Carpentry, Joinery, Roofing, Framing, etc., fully explained and illustrated by large scale diagrams in two colors. Royal Quarto. Post-paid, \$6.00.



Woodward's National Architect.—1,000 Designs, Plans, and Details for Country, Suburban, and Village Houses; with Perspective Views, Front and Side Elevations, Sections, Full Detail Drawings, Specifications, and Estimates. Also, Detail Drawings to Working Scale, of Brackets, Cornices, French Roofs, Sectional and Framing Plans of French Roofs, Dormer-Windows for French Roofs, Bay-Windows, Verandas, Porches, Plaster Finish, Cornices, Ceilings, Hard-wood Mantels, and all that is required by a Builder to design, specify, erect, and finish in the most approved style. One superb quarto volume. Post-paid, \$12.00

ORANGE JUDD COMPANY,

Woodward's Cottages and Farm Houses.—188 Designs and Plans of low-priced Cottages, Farm Houses, and Out-Buildings. Post-paid, \$1.50.

Woodward's Suburban and Country Houses.—70 Designs and Plans, and numerous examples of the French Roof. Post-paid, \$1.50.



Woodward's Country Homes.—150 Designs and Plans, with Description of the Manner of Constructing Balloon Frames. Post-paid, \$1.50.

Woodward's Graperies and Horticultural Buildings.—Designs and Plans of Hot-Beds, Cold-Pits, Propagating Houses, Forcing Houses, Hot and Cold Graperies, Green Houses, Conservatories, Orchard Houses, etc., with the various modes of Ventilating and Heating. Post-paid, \$1.50.

Wheeler's Rural Homes.—Houses suited to Country Life. Post-paid, \$2.00.

Wheeler's Homes for the People.—100 Original Designs, with full Descriptions, and Constructive and Miscellaneous Details. Post-paid, \$3.00.

Harney's Barns, Out-Buildings, and Fences.—Containing Designs and Plans of Stables, Farm-Barns, Out-Buildings, Gates, Gateways, Fences, Stable Fittings and Furniture, with nearly 200 Illustrations. Royal quarto. Post-paid, \$6.00.

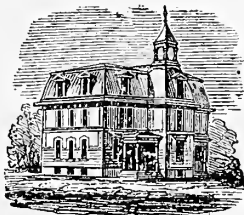

Eveleth's School-house Architecture.—A new and original work, containing Seventeen Designs for School-houses, Sixty-seven Plates with Perspectives, Elevations, Plans, Sections, Details, Specifications all drawn to working scale, with methods of Heating and Ventilation. Large quarto. Post-paid, \$6.00.

Copley's Plain and Ornamental Alphabets.—Giving examples in all styles, together with Maps, Titles, Borders, Meridians, Ciphers, Monograms, Flourishes, etc., adapted for the practical use of Surveyors, Civil Engineers, Draughtsmen, Architects, Sign Painters, Schools, etc. Post-paid, \$3.00.

Publishers, 245 Broadway, New York.

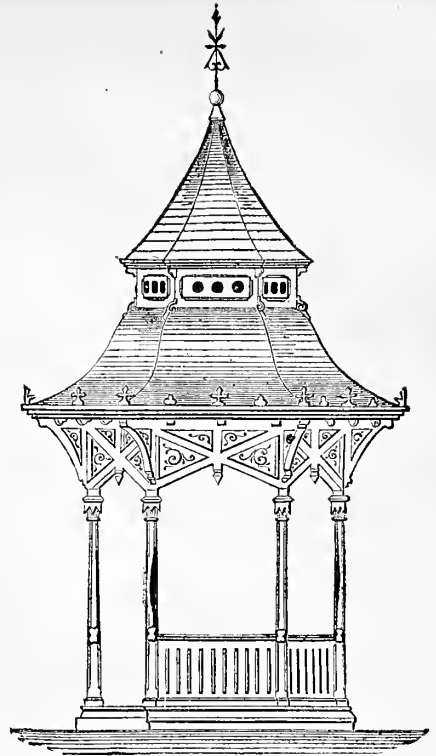

A Practical Book, one that Architects, Builders, and Carpenters can not afford to be without, entitled

DETAIL, COTTAGE, AND CONSTRUCTIVE ARCHITECTURE,

Containing 76 FULL PLATES, 20 plates more than before offered in a similar work for Ten Dollars.

Published under the direction of A. J. BICKNELL.

Showing a great variety of Designs for Cornices, Brackets, Windows and Window Caps, Doors, Plazas, Porches, Bay and Dormer Windows, Observatories, Towers, Chimney Tops, Balconies, Canopies, Scrolls, Gable and Sawed Ornaments, Fences, Stairs, Newels, Architraves, Mantels, Plaster Finish, etc., etc.; including Forty-five Perspectives, Elevations and Plans of Modern Designs for Cottages with Details, and Eighteen Elevations of Summer Houses, Villas, Seaside Cottages, and Country Houses, together with Fourteen Designs for Street and Store Fronts, with Inside Finish for Stores and Banks; also, Framing for Dwellings, Barns, Exhibition Buildings, Roofs, Bridges, etc., etc., making in all a Practical Book for Architects, Builders, Carpenters, and all who contemplate Building or Remodeling Wood, Stone, or Brick Buildings. One Large Quarto Volume, sent Free by Mail or Express, on receipt of Price.....\$10.00.

CARPENTERS' and BUILDERS' ASSISTANT,

And Wood Workers' Guide,

By L. D. GOULD, Architect and Practical Builder.

Containing 23 Plates, fully described; also, tables of the strength of materials; technical terms used by carpenters, etc., etc. This work is intended to combine all the knowledge the workman requires to construct any design in carpentry, by a new and easy system of lines, reducing the science of construction to an agreeable and pleasant occupation, rather than an unpleasant task. One 8vo. volume, bound in cloth. Price.....\$3.00.

ARCHITECTURE.

By CUMMINGS & MILLER.

A Practical Book on Architectural Details; containing over One Thousand Designs and Illustrations, showing the manner of constructing Cornices, Doorways, Porches, Windows, Verandas, Railings, French Roofs, Observatories, Plazas, Bay-Windows, Cut-Stone Work, various styles of Modern Finish, and Street Fronts of Houses, Stores, etc., etc. One Large Quarto Volume. Price, post-paid....\$10.00.

Loth's Practical Stair-Builder.

A complete Treatise on the Art of Building Stairs and Hand-Rails. Designed for Carpenters, Builders, and Stair-Builders. Illustrated with Thirty Original Plates. By C. EDWARD LOTH, Professional Stair-Builder. One large Quarto Volume. Bound in Cloth. Price.....\$10.00.

Address

ORANGE JUDD COMPANY,

245 BROADWAY, NEW YORK.

CHEAP FARMS AND FREE HOMES

IN THE

Great Platte Valley, THE GARDEN OF THE WEST.

A LAND GRANT OF

12,000,000 Acres

OF THE

**Best Farming, Grazing, and
Mineral Lands in America.**

THE

Union Pacific Railroad Co.

OFFER FOR SALE

3,000,000 Acres

OF CHOICE

**Farming and Grazing
Lands**

ON THE LINE OF THE ROAD IN THE

STATE OF NEBRASKA.

**ON TEN YEARS CREDIT, IN-
TEREST ONLY 6 PER CENT.**

Cheaper in Price,

**More favorable Terms given,
Than can be found Elsewhere.**

**Convenient to Markets
East and West.**

**NOW IS THE TIME
TO SECURE A HOME!!**

JUST OUT!

The Second Number of

THE PIONEER,

A handsome ILLUSTRATED PAPER, with Maps, etc., and containing the Homestead Law, also the new TIMBER LAW. Mailed free to all applicants, by addressing

O. F. DAVIS,

Land Commissioner, U. P. R. R. Co.,
OMAHA, NEB.



FOR SALE BY DRUGGISTS.

THE PENN MUTUAL LIFE INSURANCE COMPANY OF PHILADELPHIA.

ASSETS ACCUMULATED, \$1,427,996.96.
The Penn is a purely mutual Company. All of its surplus premiums are returned to the members every year. Dividends may be applied to reduce the premium or increase insurance as desired. **SAM'L C. HUEY, Pres.**
General and Local Agents wanted in the Middle and Western States. Apply to H. S. STEPHENS, Vice Pres., No. 92 Chestnut Street, Philadelphia, Pa.

\$25 Per Day guaranteed using our **Well Auger** and Drills. Catalogue free. **W.W. GILES, St. Louis, Mo.**



Hussey's National Cottage Architecture.

New and Original Designs, Working Scale Drawings, and Details for all Styles of low-priced Houses, with Specifications and Cost. *Just published.* Royal quarto. Post-paid, \$6.

WOODWARD'S 1,000 WORKING DRAWINGS, **NATIONAL ARCHITECT.** Plans, Details, Specifications, and Estimates. TWELVE DOLLARS, post-paid.
MONCKTON'S NATIONAL STAIR BUILDER. SIX DOLLARS, post-paid.
MONCKTON'S NATIONAL CARPENTER and JOINER. SIX DOLLARS, post-paid.

A New and Revised Edition of Peter Henderson's well-known Work, Gardening for Profit.

A Guide to the Successful Cultivation of the Market and Family Garden.
By **PETER HENDERSON.**
Finely Illustrated. Price, Post-paid, \$1.50.

The success of this book has probably not been equaled by that of any horticultural work of the present day. Its popularity is due to the fact that it tells just what people wish to know—the way in which the author made money by gardening—and puts in a plain, striking light all the requisites to success. The writer was not afraid to have people know that he cultivated his land for profit, and, more than that, he was quite willing that all should know and practice, if they chose, the very processes which he had found most conducive to the desired end. The late Horace Greeley said of this book: "There are marvels of transformation and rapid reproduction recorded therein, which might well shame the dull fancy of the author of Aladdin or of Kaloolah. There is no theory about it; a man who has made himself rich by market-gardening plainly tells our young men how they can get rich as easily as he did, and without wandering to California or Montana for it either." And tens of thousands who have read and profited by the work could give similar testimony. It is unquestionably the most thorough and the best book of its kind that has yet come from the hand of an American author. In the revised edition several new chapters will be found, and in the selection of varieties much has been changed, though the plan of the work is the same as before.

The following is a specimen of hundreds of letters that have been received concerning this work.

I was an early purchaser of "Gardening for Profit," a reading of which made the possession of "Practical Floriculture" a necessity. I sincerely thank the writer for giving us non-professionals what we have so long needed—some plain common-sense directions for our assistance—and for having exploded some outrageous humbugs which have been perpetuated in all previous works on gardening and floriculture from time immemorial, tending to produce the conviction that nothing but professional skill could raise a vegetable or flower. **LUTHER NEWCOMB,**
May 4, 1873. Montpelier, Vt.

The following voluntary notice of this book comes from a Western market gardener and shipper of vegetables, and is a specimen of similar testimony from very many quarters.
"March 23d, 1874.

"If this should go to Mr. Henderson, I would say that I believe the gardeners of this country would gladly hail another edition of 'Gardening for Profit'; at least, I thank him for that little work. Through its influence I left a paying manufacturing business and began to follow its teachings. This was three years ago. Now I have a market garden of thirty acres and 400 four-foot sash, and enjoy myself as I never did before. Again I thank him."

Either of the above books sent post-paid on receipt of price by

ORANGE JUDD COMPANY, 245 Broadway, N. Y.

Beckwith Sewing Machines

\$12 and \$20.

We have offered as a Premium, and also for sale, for more than a year past, the **Beckwith Sewing Machine**, which has been fully described in previous numbers of this paper. We have already given and sold more than one thousand of these machines, and testimonials of satisfaction have come from every quarter.

We still offer the **Beckwith Sewing Machine, Improved**, price \$12. A new and very simple braiding-foot has been made, by which a child can sew on braid without the least trouble, following any desired pattern with ease; also a new arm, spiral spring and lever for raising the presser-foot, all of which are now set in a position that leaves the needle free to be threaded. The joint is much enlarged, and the machine is otherwise greatly strengthened and improved. The use of the braider-foot alone will be valued more than the cost of the machine.

Each of these machines is put in a neat, compact box, with *hemmer and guide; oil-can with oil; thread; different-sized needles, etc.*, with full Printed Directions for using. On receipt of \$12 we will send one of these machines to any address, expressage to be paid by the purchaser.

The Machine as a Premium.

We will give one of these \$12 machines to any one who will collect and forward sixteen subscribers to *American Agriculturist* for one year, at \$1.50 each, expressage on the machine to be paid by the recipient of it.

THE BECKWITH PORTABLE FAMILY SEWING MACHINE.

PRICE \$20.

Enlarged and Improved. Its Weight is 7 Pounds.

While we continue the offer of the Improved \$12 Machine as heretofore, we now offer the new

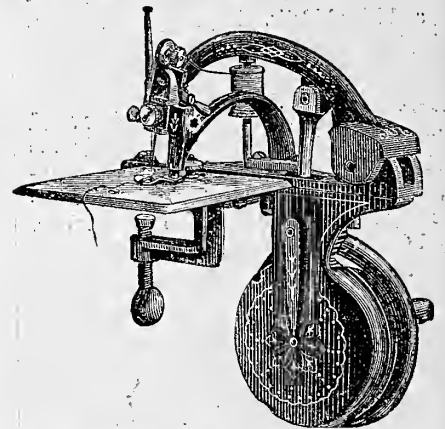

PORTABLE FAMILY MACHINE,

price \$20, which comprises all the excellencies of the former, with many valuable improvements. Its size and power are increased, and its capacity thus very much enlarged, without impairing its portability. There have been added cam and eccentric movement, a balance-wheel, and also an oscillating needle-clamp, by which the length of stitch can with the greatest ease be changed to the finest shade of variation without touching the needle.

To any one sending us \$20, we will send one of the Machines (packed in a neat, portable case, with handle to carry it easily), expressage to be paid by purchaser.

The Machine as a Premium.

We will give one of these \$20 Machines to any one who will collect and forward to us **Thirty Subscribers to American Agriculturist for one year at \$1.50 each, or One Hundred at \$1 each, expressage on the Machine to be paid by the recipient of it.**

Almost any lady can readily secure the small number of subscribers required to get either the \$12 or the \$20 Machine as described above; or some friend can thus obtain it for her as a present.

**ORANGE JUDD COMPANY,
245 BROADWAY, NEW YORK.**

SEPTEMBER, 1874.



AMERICAN AGRICULTURIST

FOR THE FARM, GARDEN & HOUSEHOLD.

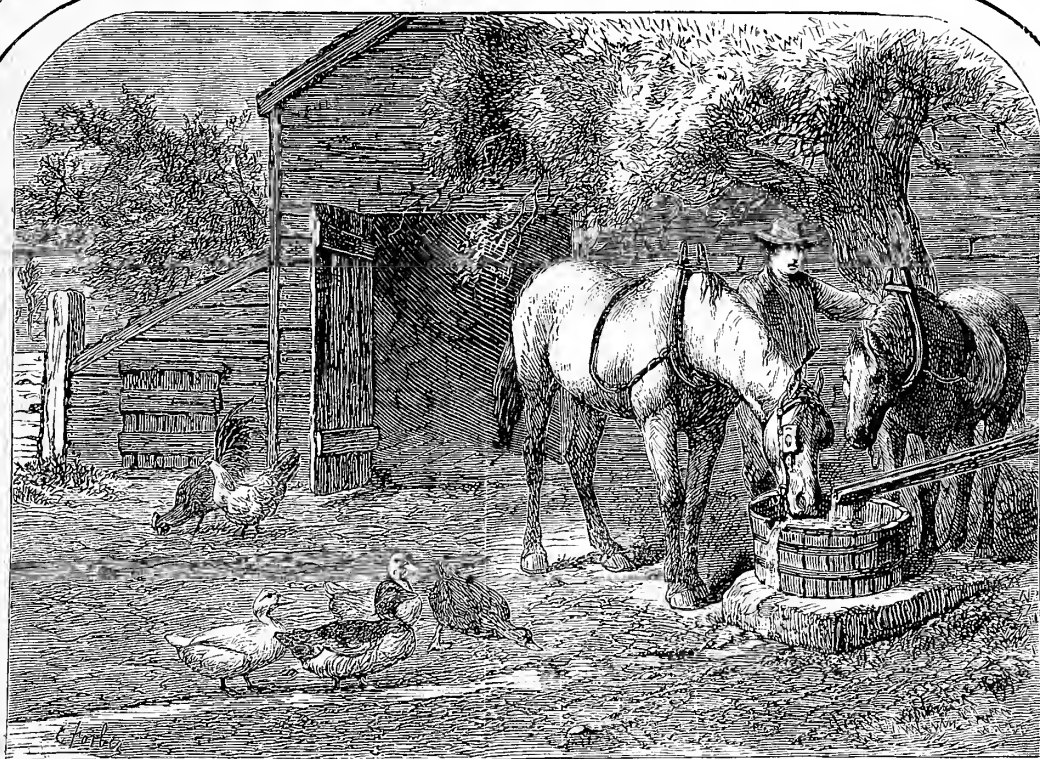

Vol. XXXIII

Number 9

PUBLISHED BY THE
ORANGE JUDD COMPANY,
245 BROADWAY,
NEW-YORK.

SUPERIOR STANDARD WORKS.

Published by **ORANGE JUDD COMPANY.**

THE HORSE.

FRANK FORESTER'S HORSE OF AMERICA.

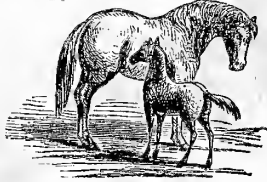

By **HENRY WM. HERBERT.**

Revised, corrected, enlarged, and continued to 1871,

By **S. D. and B. G. BRUCE.**

Always an **ACKNOWLEDGED STANDARD**, and now the most **COMPLETE and AUTHENTIC** Work on the **HORSE**. With steel-engraved portraits of **Thirty of the most famous**

REPRESENTATIVE HORSES,

including pedigrees, histories, and performances.

Two superb royal octavo volumes of upward of 1300 pages.

Post-Paid, Ten Dollars.



WALLACE'S

American Trotting Register.

CONTAINING ALL THAT IS KNOWN OF THE

PEDIGREES OF TROTTING HORSES,

their ancestors and descendants, with a record of

All published performances in which a mile was trotted or paced in 2.40 or less,

from the earliest dates until the close of 1868, and a full record of the performances of 1869 and 1870.

Giving complete Summaries of over 6,000 Contests.

With an **INTRODUCTORY ESSAY** on the true origin of the American Trotter. And a set of **Rules** for the government of all trials of speed. By **J. H. WALLACE**, compiler of Wallace's American Stud-Book. Royal octavo.

Post-paid, Ten Dollars.

WALLACE'S AMERICAN STUD-BOOK.

VOL. ONE. BEING A COMPILATION OF THE

PEDIGREES OF AMERICAN AND IMPORTED BLOOD HORSES,

from the earliest records, with an **APPENDIX** of all named animals without extended Pedigrees prior to the year 1840. And a **SUPPLEMENT**, containing a history of all Horses and Mares that have trotted in public from the earliest trotting races until the close of 1866. By **J. H. WALLACE**. Royal octavo of over 1,000 pages elegantly bound in extra cloth, beveled boards, and splendidly illustrated.

Post-paid, Ten Dollars.

Horse Portraiture. — BREEDING,

REARING, AND TRAINING TROTTERS. Preparations for Races, Management in the Stable, on the Track, Horse Life, etc. By **JOSEPH CAIRN SIMPSON**. Post octavo. Post-paid, \$3.00.

FIELD SPORTS.



Frank Forester's Field Sports.

Embracing the Game of North America, Upland Shooting, Bay Shooting, Wild Sporting of the Wilderness, Forest, Prairie, and Mountain Sports; Bear Hunting, Turkey Shooting, etc. 13th edition, revised and illustrated. Two post octavo volumes. Post-paid, \$5.00.

Frank Forester's Fish and Fishing.

100 engravings. Embracing a full illustrated description of the Game Fish of North America; Trout and Salmon Fishing; Shoal Water and Deep Sea Fishing; Lake and River Fishing; Trolling, Fly Fishing, etc. 12th edition. One post octavo volume. Post-paid, \$3.50.

Frank Forester's Complete Manual.

For Young Sportsmen, of Fowling, Fishing, and Field Sports. With directions for handling the Gun, the Rifle, and the Rod. Art of Shooting on the Wing. The Breaking, Management, and Hunting of the Dog. The varieties and habits of Game, River, Lake, and Sea Fishing. Post octavo. Post-paid, \$3.00.

Frank Forester's American Game in its SEASONS. Fully Illustrated and Described. New edition, post-paid, \$3.00.

The Dog.

By Dinks, Mayhew & Hutchinson. Compiled and edited by Frank Forester. Containing full instructions in all that relates to the Breeding, Rearing, Breaking, Kenneling, and Conditioning of Dogs, with valuable recipes for the treatment of all diseases. Illustrated. Post octavo. Post-paid, \$3.00.

The Dead Shot:

Or, Sportsman's Complete Guide; a Treatise on the use of the Gun, with Rudimentary and Finishing Lessons in the Art of Shooting Game of all kinds. By Marksman. Post-paid, \$1.75.

The Crack Shot:

Or, Young Rifleman's Complete Guide; being a Treatise on the use of the Rifle, with Lessons, including a full description of the latest improved breech-loading weapons; rules and regulations for Target Practice, and directions for Hunting Game. By Edward C. Barber. Post-paid, \$1.75.

Gun, Rod, and Saddle.

Nearly fifty practical articles on subjects connected with Fishing, Shooting, Racing, Trotting, etc. Post-paid, \$1.

Practical Trout Culture.

By J. H. Slack, M. D., Commissioner of Fisheries, New Jersey. Fully illustrated and describing thoroughly all that is requisite to successful Trout Culture. Post-paid, \$1.50.

AGRICULTURE.

Woodward's Graperies and Horticultural

BUILDINGS. Designs and Plans of Hotbeds, Cold Pits, Propagating Houses, Forcing Houses, Hot and Cold Graperies, Greenhouses, Conservatories, Orchard Houses, etc., with the various modes of Ventilating and Heating. Post-paid, \$1.50.

Jacques' Manual of the Garden, Farm,

AND BARN-YARD. Embracing the Cultivation of Vegetables, Fruit, Flowers, all Field Crops, Details of Farm Work and Rearing Domestic Animals. New and Revised Edition. One volume. Post-paid, \$1.75.

Young Farmer's Manual.

Vol. I. The Farm and the Workshop, with Practical Directions for laying out a Farm, Erecting Buildings, Fences, Farm Gates, Selecting good Farm and Shop Tools, and performing Farm Operations. Fully illustrated. Post-paid, \$1.75.

Young Farmer's Manual.

Vol. II. How to Make Farming Pay, with full Details of Farm Management, Character of Soils, Plowing, Management of Grass Lands, Manures, Farm Implements, Stock, Drainage, Planting, Harvesting, etc. Illustrated. Post-paid, \$1.75.

Husmann's Grapes and Wine.

The Cultivation of the Native Grape and Manufacture of American Wine. By Geo. Husmann, of Missouri. Post-paid, \$1.50.

Elliott's Lawn and Shade Trees.

For Planting Parks, Gardens, Cemeteries, Private Grounds, and Avenues. Fully illustrated and described. Post-paid, \$1.50.

Fuller's Forest Tree Culturist.

The Cultivation of Forest Trees for Shade, for Shelter, for Fuel, for Timber, and for Profit. Illustrated. Post-paid, \$1.50.

ORANGE JUDD COMPANY, 245 Broadway, N. Y.

JUCUNDA, OUR NO. 700,

STRAWBERRY PLANTS, grown in pots for Fall planting, will bear a full crop next season. We offer

\$20 PREMIUM

to the person who will produce the most fruit from 100 plants next season. Price Six dollars.

GRAPE VINES,

large stock 1 and 2 year old, fine quality—cheap. Catalogue of Vines, Plants, Trees, &c., now ready—sent free. Wholesale List free.

GRIMES & MEYER,

Knox Fruit Farm, Box 115, Pittsburgh, Pa.

The Home Corn-Sheller.

The best hand-sheller for family use in the market.

EVERY MACHINE WARRANTED.

Price, \$2.50. Agents and Canvassers wanted. Address **LIVINGSTON & CO.,** Iron Founders, Pittsburgh, Pa.

THE MISFORTUNE OF A RUP-

TURE can be easily remedied by wearing the new Elastic Truss, without metal springs. It retains the rupture under all circumstances, is worn night and day with perfect comfort, and soon effects a permanent cure. Sold at a moderate price. It is sent by mail to all parts of the country, by the Elastic Truss Co., No. 683 Broadway, New York City. Suitable Agents would be appointed on very favorable terms where none now are.

ENGLISH CHANNEL

PRETTY FEET should be shod in **ENGLISH CHANNEL** Shoes. All ladies insist on having them. They show a dark line around the sole near the edge. They never wear ragged. They wear longer, and cost no more.

INVENTORS

Who wish to secure **PATENTS** should write to **MUNN & CO., 37 Park Row, New York, for Advice and Pamphlet, 108 pages, FREE.**

BEAUTIFYING COUNTRY HOMES.

AN ELEGANT QUARTO VOLUME.

By **J. WEIDENMANN.**

PRICE, POST-PAID, \$15.00.

This magnificent work is illustrated not only with numerous fine wood-engravings, but also with seventeen full-page and seven double-page colored lithographs of places already improved. It embodies the results of a long practice in landscape architecture and rural adornment, and while its teachings are in accordance with the received rules of art, they are thoroughly practical in their character. It is one of the most elegant, and ought to prove one of the most useful works ever issued in the country. The work, both in its letter-press and colored lithographs, is beautifully printed, and it is elegantly bound in beveled boards.



Hussey's National Cottage Architecture.

New and Original Designs, Working Scale Drawings, and Details for all Styles of low-priced Houses, with Specifications and Cost. *Just published.* Royal quarto. Post-paid, \$6.

WOODWARD'S 1,000 WORKING DRAWINGS, **NATIONAL ARCHITECT.** Plans, Details, Specifications, and Estimates. TWELVE DOLLARS, post-paid.

MONCKTON'S NATIONAL STAIR BUILDER. SIX DOLLARS, post-paid.

MONCKTON'S NATIONAL CARPENTER AND JOINER. SIX DOLLARS, post-paid.

Either of the above books sent post-paid on receipt of price by

ORANGE JUDD COMPANY, 245 Broadway, N. Y.

ADVERTISING RATES.

American Agriculturist.

ENGLISH EDITION.

Inside Pages, \$1.50 per line (agate), each insertion. Open Pages (open without cutting), \$2 per line. Last Page, and 2d and 3d Cover Pages—\$2.50 per line. Page next to Reading and Last Cover Page—\$3.00 per line. No advertisement inserted for less than \$5.00.

GERMAN EDITION.

Inside Pages, 25 cents per line, each insertion. Business Notices and Last Page, 40 cents per line. No advertisement inserted for less than \$1.00.

No Advertisement of Medicines or Humbugs received. Address all orders to

ORANGE JUDD COMPANY,
245 BROADWAY, NEW YORK.

AMERICAN AGRICULTURIST

FOR THE

Farm, Garden, and Household.

"AGRICULTURE IS THE MOST HEALTHFUL, MOST USEFUL, AND MOST NOBLE EMPLOYMENT OF MAN."—WASHINGTON.

ORANGE JUDD COMPANY,
PUBLISHERS AND PROPRIETORS.
Office, 245 BROADWAY.

ESTABLISHED IN 1842.

Published also in German at \$1.50 a Year.

\$1.50 PER ANNUM, IN ADVANCE.
SINGLE NUMBER, 15 CENTS.
4 Copies for \$5; 10 for \$12; 20 or more, \$1 each.

Entered according to Act of Congress, in August, 1874, by the ORANGE JUDD COMPANY, at the Office of the Librarian of Congress, at Washington.

VOLUME XXXIII.—No. 9.

NEW YORK, SEPTEMBER, 1874.

NEW SERIES—No. 332.

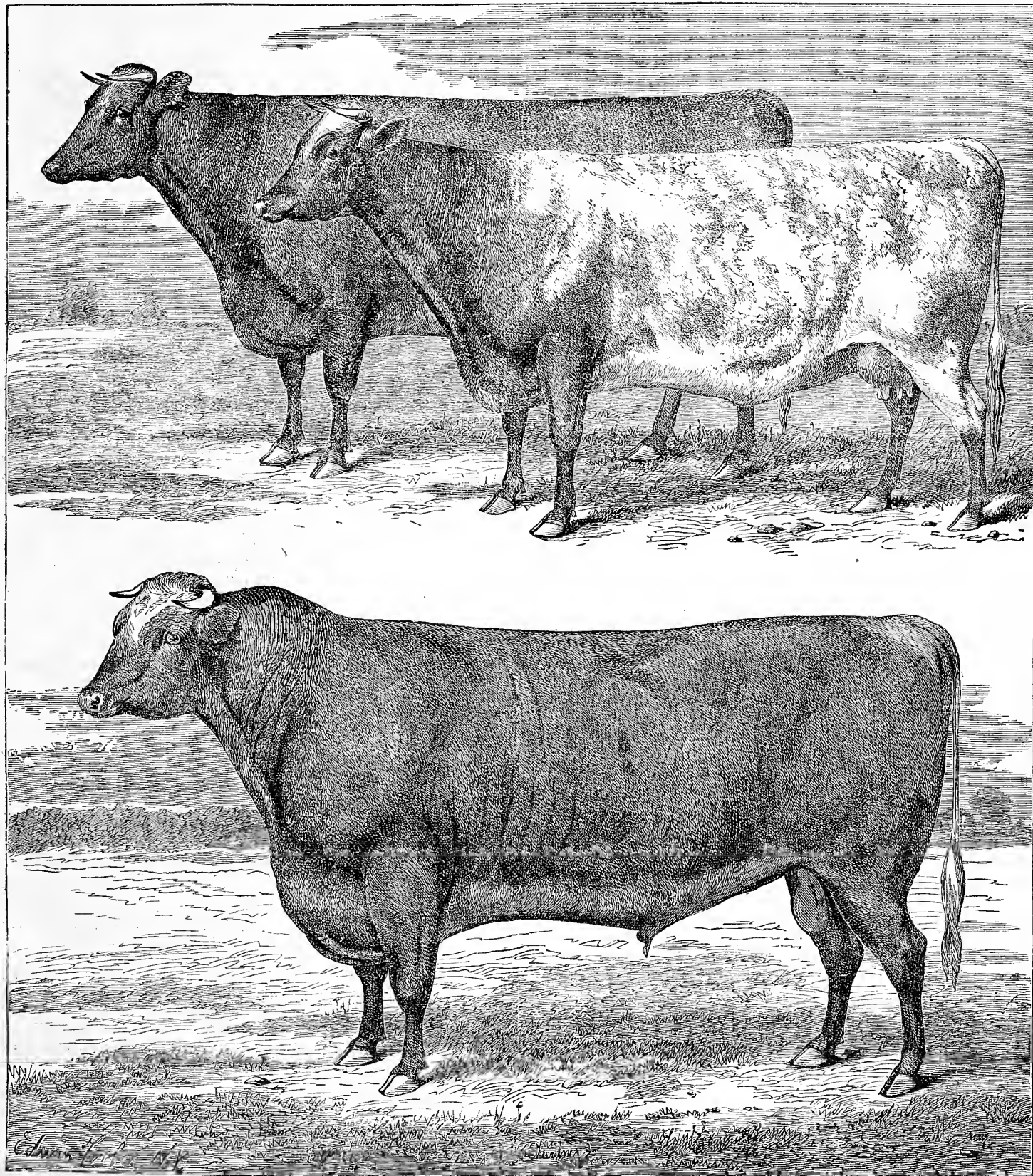

MOUNT FORDHAM SHORTHORNS.—(See page 332.)—Drawn and Engraved for the American Agriculturist.

Contents for September, 1874.

Barn Doors, Wooden Hangings for... 2 Illustrations... 330
Bee Notes... 330
Boys and Girls' Columns—Water Melon-choly Accident—Aunt Sue's Puzzle-Box—Little Garden—Aunt Sue Goes to the Hippodrome—Dogs—Little Cleaners... 2 Illustrations. 347, 348
Butter, Inspection of... 339
Canning Tomatoes, etc... 331
Cattle Barn, Western... 2 Illustrations... 336
Cattle, Mount Fordham Herd... Illustrated. 321, 332
Cider and Cider Vinegar... 5 Illustrations... 339
Clod Crusher, Simple... Illustrated... 336
Ducks, Imperial Pekin... Illustrated... 333
Fairs to be held... 353, 354
Farm Work for September... 332
Fish, Grayling... Illustrated... 333
Flower Garden and Lawn in September... 324
Flowers, Preserving—Winter Bouquets... 343
Fruit Garden in September... 324
Game Fowls and Poultry Societies... 330
Greenhouse and Window Plants in September... 324
Hollyhock Fungus—Cotton in danger... Illustrated... 342
Household Department—Corn Knife—Home Topics—Farmers' Tables... 3 Illustrations... 345, 346
Kitchen Garden in September... 324
Market Reports... 324
Mink or Rat Traps... 3 Illustrations... 337
Oak, Enemies of... 5 Ill... 344
Ogden Farm Papers, No. 53—Jersey Cattle Club—Color of Skin—Yield of Butter—Guernsey and Jersey—Hay Making... 331, 332
Onions Sown in the Fall... 341
Orchard and Nursery in September... 323
Plants, Broad-leaved Acanthus... Illustrated... 341
Plants, Florida Air... Illustrated... 343
Plants, Palmate Spiraea... Illustrated... 341
Road-dust... 335
Roller, Cement... 3 Ill... 337
Rose Growing in Winter... 342
Seeding, Thick or Thin... 335
Tiles, Kiln for Burning... 3 Illustrations... 338
Tobacco in the Connecticut Valley... 338
Walks and Talks on the Farm, No. 129—Wheat—Manure—Hessian Fly—Hay—Corn—Petroleum—Thrashing Wheat—Stacks... 334, 335
Wagon-Jack, Handy... 2 Illustrations... 336
Water for Stock... Illustrated... 336
Wire Fence Tightener... Illustrated... 337

INDEX TO "BASKET," OR SHORTER ARTICLES.

Blackberries... 327 Irrigating Corn or Cotton... 328
Butchers' Offal... 326 Leaks in a Roof... 328
Car Load, A... 329 Liliun auratum, Mons-Carrots, Wild... 327 trous... 327
Cattle, Herford... 329 Lime on Wheat... 326
Cattle in the South... 329 Lime Spreading... 327
Chairs, Comfortable Coun- Loans, Procuring... 329
try... 326 Lump upon a Mare... 326
Cheese Factory... 328 Muck, About... 330
Cider Mills... 326 Milk, Bloody... 328
Cisterns, Leaky... 328 Onion Grub... 327
Cobs, Small or Large... 329 Paris Green... 326
Colorado Potato Beetle in Parrots, Treatment of... 329
New Jersey... 327 Phloxes, Perennial... 326
Cornell University... 325 Plows, To Keep free of
Corn for Fodder, Cutting... 328 Rust... 329
Corn Raising... 328 Poultry, Pedigree Book... 326
Cow, A gorged... 328 Pump, Submerged... 326
Cow's Does, Clipping a... 328 Rabbits... 326
Crops in Kansas... 326 Railway Gazetteer... 325
Death of H. Stephens... 326 Raspberries, New... 327
Death of J. S. Gould... 325 Rather Mixed... 329
Ditching... 329 Rye, Seed... 326
Draining... 328 Spaying Heifers or Cows... 328
Draining a Pond... 330 Spring, To Raise a... 328
Eastman's Business Col- Straw, Etc., Dispose of... 328
lege... 327 Sugar from Beets... 328
Eggs for Pullets... 328 Sunflowers... 326
Elliott, F. R... 326 Superphosphate, Appli-Emasculation, Safe... 329 cation of... 326
Fair List... 325 Superphosphate, Charles-Farm, Selling the... 329 ton... 328
Fodder Crops in the So'th... 328 Sweet Potatoes... 328
Garden Questions... 328 Sweet Potatoes for Feed... 328
Goose, to Recognize a... 329 Tree Planting in Neb... 329
Grain Binders... 329 Virginia State Ag'l. Soc... 326
Grain, Low Freights on... 329 Weed, Named... 326
Grass, Permanent... 328 Weigh and Measure
Guano or Plaster Sowing... 326 everything... 326
Harvest Home Celebration... 329 Wheat and Guano Drill... 327
Hedge Rows, Breaking... 328 Wheat, Bone Dust for... 328
Humbugs, Sundry... 326 Wheat on Corn Stubble... 328
Hurdles, Iron... 326 Wheat, Seed... 328
Hydrangea... 326 Willow, White... 327
Ice-Houses—Milk-Rooms... 326 Wistaria... 326

Calendar for September.

Table with columns for Day of Month, Day of Week, Sun rises, Sun sets, Mo'n rises, Mo'n sets for Boston, N. York, N. Y. City, Wash'g, and Chicago. Includes sunrise and sunset times for each city.

PHASES OF THE MOON.

Table showing moon phases for Boston, N. York, Wash'g, and Chicago. Columns include Moon, Day, H. M., and ev. times.

AMERICAN AGRICULTURIST.

NEW YORK, SEPTEMBER, 1874.

In September the farmer begins to receive returns for months of care and labor. He has hitherto been easting bread upon the waters, and now it returns after many days. His reward is now in proportion to his faith. If he has believed in what he has read in these pages, in the fruits of his own and other's experiences, and in the teachings of intelligence and common sense, he has not been chary of hard work, constant attention, and generous treatment of his land and crops; he has fed his land, and now his fields will feed him in return. Now the farmer learns that out of nothing, nothing comes. If he has put nothing upon his fields, his crop is poor. If, on the other hand, he has well and intelligently fertilized and worked, he finds in spite of seasons, that he has barns full, and the promise of harvest is surely fulfilled to those who carefully meet the requirements of seed time. The better the farmer the better the crops, and the risks of seasons and unfavorable weather, bring disaster only to the farmer who neglects the precautions by which he may avoid them. Generally the fall wheat crop has yielded well, and has been harvested cheaply and in good condition. There is a good market for it. Crops in Europe are not over an average, and there are vast deficiencies in stocks to be made up. Besides our spring crops will be deficient. Spring wheat is a comparative failure in many places, and the surplus of the fall crop will be partly needed to meet this deficiency. Oats and corn will be below the average, and hay is short in the West, although plentiful in the East. Prices therefore will be satisfactory on the whole, if grain is not sacrificed, and there is no good reason why farmers should hasten to put their grain into the hands of speculators, that they may hold it for a rise. The outlook is favorable to steady prices if not to some advance. The Agricultural Fairs are now in season. To attend the State and County Fairs, should be made a duty as it should be a pleasure. Every farmer should strive to be a competitor at his local fair. We wish there could be premiums offered for the best managed farms here, as there are in England, and plowing matches for farmers' boys. Competition induces study as well as work, and it is thought and study that we want. No farmer in the world works harder or more

steadily, than an American farmer, or has fewer idle days. But with the increase of machinery, and the need of better farming, more study and knowledge are needed. To give the best matter for study, and the most trustworthy knowledge, is the whole purpose of the American Agriculturist. And it is our desire to reach every farmer in the country, for we work for the whole country, and for no one section or locality alone.

Hints about Work.

Plowing for winter wheat, should be finished by the first week of September in this latitude, and in the West as far South as Kansas. Further South, a month later will be time enough. Two plowings of an oat or barley stubble should be given, that the scattered grain which has sprouted may be killed. It is a mistake to suppose that oats are a protection to the young wheat. On the contrary they are weeds, and rob the young wheat plants of their nourishment, to their injury. We do not care to have the surface too fine and mellow. A cloddy surface will do no harm if there is a mellow bed below for the seed. In good time these clods will crumble down, and until then they are a protection to the plants.

Manuring.—A few loads of good well-rotted manure harrowed into the surface, or covered with a very light furrow at the second plowing, is better than twice as many loads spread in the winter as a top dressing. Strong plants at the start are what we want. If there is food at hand, the roots from the sprouting seed find it and make a rapid growth, when growth is safety. Strong fibrous roots spreading far into the soil, are not so easily thrown out by frost, as weak puny short roots which have no hold. Thousands of young plants die for want of food in poor soil, long before any frost touches them. The manure and seed should go into the ground together. Top dressing in winter is an after expedient, useful when nothing better can be done. But it is better for the crop that it should not need it. Where no manure is at hand, 200 lbs. of Peruvian guano per acre, will give the wheat or rye a fine start. It may be followed later by a top dressing.

The selection of seed is important. Changes of seed should be made with caution, and the whole crop should not be risked at once. Experiment wisely, that is, cautiously. The fine white wheats require rich soil, and strong limestone land. The hardier red or amber wheats, are safer on gravelly land, or where the soil is not so rich. A great improvement may be made, by choosing the best and heaviest seed each year from local sources. Above all things avoid weeds. Sow clean seed, if it is picked over by hand, upon a portion of the field at least. A stock of clean seed may be raised from this for another season.

The Quantity of Seed.—This depends much upon its quality. Six pecks of plump seed that has not been broken in thrashing, and that is free from weeds, is better than two bushels taken at random from the bin. On rich clean ground wheat will lodge, that is too thickly sown. On poorer soils two bushels per acre is little enough.

Pickling the Seed.—Smut may be prevented by soaking the seed in strong brine. Pour the seed slowly into the brine in a large tub. All light imperfect grains will float and should be removed. Stir the seed, and then scoop it out on to the barn floor, and leave it for an hour to dry, or a few handfuls of finely slacked lime will dry it at once. Pickling the seed is so great an advantage, and so little trouble, that it should never be neglected, even where smut is not prevalent.

Sowing.—Experiments made in England, showed that three-inches was the best depth at which to sow wheat. Before the sprouts appeared above ground, there was abundant growth of roots, and a larger proportion of plants escaped winter killing. Even sowing can only be done by the drill. All the seed is then covered. This is not the case in broadcast sowing. If the ground is too rough or stony for the drill, it is a lesson for another year, to be remembered and acted upon in time.

A Ditching Machine.—"N. D.," New Iberia, La. We have seen a ditching machine in operation upon the prairie soils of the West, which performed excellent work. It is the Carter ditching machine, is drawn by two or four horses, cuts a deep, narrow, smooth trench, and leaves the earth upon one side of the ditch. We do not know the manufacturer's address, but from the numerous inquiries for such a machine, it is a thing that ought to be made known in the usual way.

Rye.—This crop is worth growing, both for the straw and for the grain. A few acres will furnish bands for a large field of corn, and the chopped grain with corn is excellent feed for horses. Two bushels of seed per acre is sufficient. If kept separate at harvest it may be sown at the end of a wheat field. Upon poor, light, or gravelly soils, it should be sown in preference to wheat, as a more profitable crop.

Grass Seed.—Few farmers are able to get their soil in sufficiently good tilth, or rich enough to sow grass seed alone with profit. Where it can be done conveniently, a crop of hay may be mown the next season. In this case half a bushel of timothy is a proper quantity of seed. Generally, however, it is best sown with fall grain. If clover is to be sown in the spring, six or eight quarts of timothy per acre, should be sown immediately after the grain is drilled or harrowed in. It will find sufficient covering by the gradual mellowing of the soil. A quarter of an inch of covering is all that is needed. Sow only clean fresh seed. If the seed is old, one half more will be needed.

Fall Fallowing.—This should not be neglected. The corn stubble should be thoroughly cultivated between the shoeks, as soon as the corn is cut. Potato ground that is unoccupied should be harrowed, and every opportunity offered for the weeds to grow. A harrowing will then destroy them, and start others to grow which may be killed in the spring. Every way in which weeds may be killed should be studied and put in practice.

Clover Seed.—It is useless to try to get a crop of seed and fodder at the same time, from a late cutting of clover. It is best to devote all the attention to saving the seed. If it is exposed to rain it is easier thrashed, and the labor saved is of more value than the poor fodder which could be secured. It should be thoroughly dry when put into the barn. If taken from home to be hulled it is worth while to save the chaff for the manure pile. We have hulled clover in the ordinary thrashing machine, by lowering the concave and fastening a strong board in front. The seed and chaff will work out below the cylinder if one side is opened.

Buckwheat.—This crop upon low ground is easily injured by frost. Rather than allow the crop to be injured, it is better to cut it early, although some of the grain be green. In the stook it is safe, and the unripe grain will mature by a few days exposure. In drawing home the crop, spread a barn sheet in the wagon to catch the loosened grain. Thrash, as it is drawn from the field. Clean up the seed at once to prevent heating, and put it into shallow bins. If the grain heats it should be turned. The first grain in the market always brings the best price.

Beans.—Harvest beans carefully to preserve the color. Rain or mildew will reduce the value 50 per cent. Stack in tall narrow heaps around single stakes set in the ground, and cap the stacks with straw to shed rain. Thrash as soon as dry, and store in barrels in a dry place.

Cutting Corn.—This is the great work of the month. As soon as the corn is glazed to the tips of the ears, it is ready to cut. If struck with frost the fodder is seriously injured. Topping corn is excusable only where fodder is worth nothing. We have not found that place yet. The heaviest Western corn may be profitably cut up to the butts for fodder. The practice of leaving a hill uncut to hold up the shock, is more troublesome in the end than setting up the shoeks securely at first. Spread the butts well, and tie the tops of the shoeks with rye straw bands. There will be no more shocks blown over, than if a hill is left uncut in the center of each. Our plan is to cut five hills each way, or if in rows 20 feet of each row for five rows. This makes a shock that will dry thoroughly in two weeks. Corn cut before the 10th should be husked before the end of the month. Cold fingers and benumbed hands make slow husking. A good husking machine is made, but strangely no one seems to want it. There are a great many farmers who could profitably invest \$100 in a good corn husker.

Potatoes.—As this crop ripens it should be dug. Tender early sorts such as Early Rose, are often damaged greatly by wire worms or white grubs. We never made anything, but often lost, by storing potatoes instead of selling them. 75c. a bushel is worth more now than a dollar in spring. A good way to dig potatoes in drills, is to plow a furrow close to the row going up, then do the same down the next row; then plow beneath the first row turning it upon the first furrow, and so on through the field. The potatoes are all exposed and can be raked out with the hoe or barrow. To sort them in the field is a saving of time and labor. Gather up the tops with the horse rake, and cart them to the barn-yard.

Vermin are now gathering their harvest, and making nests for the winter. Get rid of the dogs, and encourage cats around the buildings. Feed them regularly, and they will hunt with double vigor. Open up all hiding places to the light, and have passages around and under the bins in the granary, where cats can get in and out. Place tin caps on the posts of the corn cribs. Rats, although sagacious, may be vanquished by perseverance.

Feeding Animals.—Flesh and fat are now made at half the cost of feeding in November. Much food may now be gathered up, which costs little, and would otherwise be wasted. Boil the screenings from the thrashing machine with small potatoes for the hogs, and feed sound old corn, or what is better, corn meal. Pork made with soft corn is not cheaply made. Keep the soft corn and nubbins for the store hogs. Now is the season to buy stock for feeding during the winter, to make manure. Farmers who are economical with their feed, and have some to spare, had better buy a few head of stock, than sell hay or straw. But buy with judgment; an animal well bought is half sold.

Sheep.—If sheep are not marked, this should be done forthwith. For valuable breeding sheep, metallic ear-marks should be used. Common sheep should be marked with red chalk, or Venetian red and oil. Ewes may be marked across the shoulders; wethers across the rump; and those that are to be sold off, with a stripe down their backs. If the flock has not been separated, no time should be lost in doing this. Ewes and wethers, selected for fattening, should be put by themselves into a good pasture, and fed a little grain. Lambs should be put, along with a dry ewe for company, into a field away from the rest of the flock. As the ewes come into season, the danger from dogs is greatly increased, and watchfulness should be redoubled. It is in vain to depend upon bells, except as a means for giving alarm.

Milk Cows should receive the best attention. September packed butter is equal to June butter in quality, and will keep as well. Fresh cows at this season are very profitable, and pay well for the extra care and attention needed.

Young Stock.—Young growing animals should go into winter quarters in good condition. Their future value greatly depends upon their care during their first winter. They must be kept growing. Food must not be stinted, and shelter from early cold rains should be provided for them.

Horses.—When frost has arrived, pasture is no longer sufficient for horses. Frosted grass has but little nourishment. Fresh corn stalks cut and mixed with meal, or chopped oats and corn will make excellent fodder, and be greatly relished.

Old Stock.—There is no profit in feeding stock that is past its prime. It is waste of feed and money. As soon as any animal begins to fail it should be disposed of. Old cows, old oxen, old sows, and old hens, form the bulk of the stock upon many farms. The young animals are sold off. This is the reverse of what is wise and profitable.

Meadows and Clover Fields.—It is an unprofitable practice to pasture young clover, or the aftermath of meadows. If there is a heavy growth, moderate stocking may be allowed, but the droppings should be spread evenly.

Sundry Matters.—Harvesting machines should be oiled and put away without delay. Ditches should

be cleaned out, and the soil taken at once to the manure pile. Weeds should be cut everywhere, and if the seeds are ripe, they should be burned. Many loads of rubbish may be gathered from the roadsides and fences, for the compost heap. Fire wood should be cut and piled. Wood-lots should be cleaned up, and all work should be kept well ahead. It is no time now to be driven by work.

Work in the Horticultural Departments.

If the crops have been kept clean during the summer, the growth of weeds will now be very slight, and but little labor will be needed to destroy the few which now appear. September brings with its harvest time a season of planting, as there are numerous crops to be put in for next spring. The fall fairs should be visited, and if there are any held at accessible points, the farmer should exhibit his finest productions, both of fruit and vegetables; it will tend to keep up the interest of the society, and besides will be of great use to himself in bringing his products to notice. The local Farmers' Club or Grange ought not to be neglected, one evening a week can easily be spared for the discussion of varieties and modes of culture, manures, and gardening questions in general. A merchant studies the markets, and the different ways of putting up his wares, and a gardener should do the same, as his business will show at once the benefit or careful thought and good judgment bestowed upon it. A select library of good books, upon the different branches of horticulture, ought to be found in every gardener's house, as well as the most reliable journals.

Orchard and Nursery.

Drying Fruit.—Commence as soon as fully mature. If large quantities are to be preserved in this way, it will pay to get a fruit-drier of some kind, but as most private families only dry enough for home use, the common method is to employ the heat of the sun. Where there are hot-bed sashes, these may be used to great advantage. A frame raised a foot or so from the ground upon legs, and covered with sashes, will dry fruit and vegetables rapidly and cheaply. Make ventilating holes and cover with gauze.

Trees which were set in the spring, and now show signs of drying out, should have the soil around them removed to the depth of three or four inches, and then be thoroughly watered; afterwards replace the earth and apply a heavy mulch; this will often save them.

Seed-beds.—Shade the young plants, and keep weeded, as directed last month.

Marketing.—Carefully pick and assort all fruit sent to market. Never on any consideration shake or knock fruit from trees. Fall fruit should be marketed while firm and still fully developed.

Evergreens may be removed now as well as in the spring, if care is taken to preserve plenty of the earth around the roots. Never allow the roots to be exposed to the sun or air, and if a damp, cloudy day is selected, all the better, otherwise, water at planting.

Labels.—See that all trees and shrubs are provided with new labels where necessary. Do not, however, depend on labels entirely; a plan is easily made, and the position and name of each marked.

Seeds of peach and plum, from healthy trees, may be saved and preserved in boxes of sand for planting.

Plowing should be done as early as possible, and if new orchards are to be set, the plowing and manuring may be done at once. It is best to keep all young orchards plowed.

Nursery rows should be kept clear of weeds, with the hoe and cultivator.

Fruit Garden.

Blackberries.—Remove the fruiting canes after they have done bearing, and cut out all but three or four new canes, shortening these to five or six feet, and the side shoots to eighteen inches.

Raspberries.—Remove the old canes at once, if not already done, and tie up the new ones to stakes or wires. Fork in a good dressing of stable manure between the rows.

Currants.—Remove all suckers, and keep the ground clear of weeds.

Grapes promise to be an abundant crop this season, and plenty of boxes should be provided for marketing the fruit.

Pears.—Gather the early varieties as soon as fully matured, and when intended for home use, allow them to ripen upon shelves in the fruit-room; this will greatly increase their flavor and juiciness.

Strawberries started in pots may be set out during this month, but for general planting it is better to wait until spring. Cut off all runners where the plants are grown in hills.

Kitchen Garden.

Beans.—If there is a surplus of Limas, shell and dry for use next winter. The late string beans may be prepared as for cooking, and then packed in jars with alternate layers of salt.

Cabbages and Cauliflowers.—In order to have these early in the spring, sow the seeds in open ground about the middle of this month; the plants, as soon as large enough, are to be pricked out into cold-frames. Hoe the late crops often, and if the slug appears, dust with lime.

Corn.—As fast as the ears are gathered from the stalks, cut and feed to the cows. Do not feed the smutty ones. Dry a supply for winter use. A few ears of the earliest and best should be saved for seed. If care was taken to plant in succession, corn may be had until frost, or even later, if just before a frost comes, the stalks are cut up and set in a cool place; treated in this way, the ears will remain good for a week or ten days.

Cucumbers.—Go over the vines every day, and pick all that are of proper size for pickling. Sweet pickles and cucumber catsup, may be made of those too large for pickles.

Celery.—As soon as the nights begin to be cool, commence to earth up; this should be done only when the plant is dry, for if the leaves are wet, the probability is that the stalks will rust. Take care in earthing up, not to allow any particles of earth to enter the center of the plants.

Endive.—Blanch by covering with a board or mat, when the plants are a foot across; this will partially destroy the bitter taste which it otherwise has.

Kale.—The variety known as German Greens, is best for standing our winters; sow this month.

Manure.—Manure is both the beginning and ending of everything in the garden, and without it nothing can be accomplished, hence everything must be saved with great care, which will increase the quantity of this indispensable adjunct. Young weeds, sods, and many other little things which accumulate around the garden, will help swell the pile. Turn it over now and then, in order that it may be well rotted, and thus give a quicker return than when applied coarse.

Melons.—Turn the fruit so that it will ripen evenly; when fully ripe the stem parts readily. The fruit should be placed on ice an hour or two before eating; or else gather in the morning before the sun has heated the fruit.

Onions.—Harvest as soon as the tops fall down, dry a few days in the sun, and then store in a dry cool place.

Radi h.—Sow the Chinese Rose-colored and California White this month for winter use.

Spinach.—Sow the latter part of this month, in 15 inch drills, and keep clear of weeds.

Sweet Potatoes.—Move the vines occasionally to prevent their rooting at the joints; the larger tubers may be removed for use, and the small ones left to grow.

Squashes.—Remove the old vines of the summer sorts. Allow those of the winter varieties to root freely at the joints.

Tomatoes.—Tie up, and cut out all superfluous

branches. If the large green "worm" appears, destroy it at once, as a few will soon strip a vine.

Turnips.—Hoe Ruta-bagas, and sow the round early sorts at once, where there are any vacant spots.

Underdrains.—The present month is a good one in which to dig and lay drains, and any one who can afford it, will find by a few years' experience that it will pay.

Peat.—On many places there will be found low swampy lands, where there is plenty of peat, and where this can be had for composting with manure, it will pay to procure a lot for this purpose. This month is a good one for this work. It should be left to freeze for one winter, so that it will be fine and sweet.

Brush.—If there are any brush or large weeds in or around the garden, they should be cut and burned now, and the ashes applied to the land.

Flower Garden and Lawn.

If a good variety of annuals were planted, they will be making a fine show now. Asters, Balsams, double Zinnias, etc., make fine autumn bloomers.

Bulbs.—Set early next month all spring and early summer flowering bulbs. Order early, so that the dealer's stock will not be exhausted.

Chrysanthemums.—Pot a few plants for house flowering; set in the shade for a few days, thin out the weak shoots, and give a little manure water. The out-door plants will need tying up to stakes.

Dahlias.—Keep tied to stakes, and as soon as the flowers commence to fade, cut them off. Gladioluses require the same treatment.

Lawns.—Mow often to keep the annual weeds from flowering and seeding. Sow grass seed in any bare spots, so that it may have the benefit of the autumn rains.

Perennials and Biennials.—Sow seeds this month in well prepared beds, and keep well weeded.

Potted Plants.—Remove to the greenhouse or house, as soon as the nights begin to get cold. Wash the pots and remove all weeds, and see that no insects are taken in.

Seeds.—Gather as fast as they ripen, and before the wind has scattered them.

Greenhouse and Window Plants.

All repairs and alterations, both in the greenhouse and heating apparatus, ought to be completed this month, as a sudden frost is liable to require that many ornamental plants, which have been set out for the summer, should be taken in at once. Have ready a supply of coal, potting earth, and other articles needed during the winter.

Annuals.—Sow a few for winter flowering, especially Alyssum and Mignonette.

Bulbs.—Pot tender bulbs such as Oxalis, Cyclamen, and the like, the latter part of the month.

Callas.—Divide and re-pot in a rich turfy soil, which they particularly like.

Potting.—Commence potting tender plants which were bedded out during the summer, and also those which are to be used to propagate from.

Cuttings.—Put in cuttings of such plants as it is desirable to save.

Insects.—See that every plant is entirely cleared of insects, before putting into the greenhouse.

Pots.—Provide plenty of these for winter use of the sizes most needed.

Commercial Matters—Market Prices.

The following condensed, comprehensive tables, carefully prepared specially for the American Agriculturist, from our daily record during the year, show at a glance the transactions for the month ending Aug. 12th, 1874, and for the corresponding month last year:

Table with 5 columns: RECEIPTS, Flour, Wheat, Corn, Rye, Barley, Oats. Includes sub-headers for SALES and a final row for 25 d's last month.

Table 2: Comparison with same period at this time last year. Columns: RECEIPTS, Flour, Wheat, Corn, Rye, Barley, Oats. Rows for 28 days 1874 and 27 days 1873.

Table 3: Stock of grain in store at New York. Columns: Wheat, Corn, Rye, Barley, Oats, Malt. Rows for Aug 10, 1874, July 6, 1874, June 8, 1874, May 11, 1874, April 6, 1874, March 9, 1874, Feb. 9, 1874, Jan. 12, 1874, Dec. 10, 1873.

Table 4: Exports from New York, Jan. 1 to Aug. 10. Columns: Flour, Wheat, Corn, Rye, Barley, Oats, Peas. Rows for 1874, 1873, 1872, 1871, 1870, 1869, 1868.

Table 5: Receipts at head of tide-water at Albany each season to July 31st. Columns: Flour, Wheat, Corn, Rye, Barley, Oats. Rows for 1874, 1873, 1872, 1871, 1870.

CURRENT WHOLESALE PRICES.

Table of current wholesale prices for various commodities like Gold, Flour, Wheat, Corn, Rye, Barley, Oats, Beans, Peas, etc., with columns for July 11 and Aug. 12.

Gold has been up to 110 1/2 and down to 109—closing Aug. 12th at 109 1/2 as against 110 on July 11th. The Breadstuff trade has been quite active, but prices have been very much unsettled, largely by the unusually extensive speculative dealings in Corn and Oats, which carried values on these products up to high figures. The later transactions, however, were on a lower basis for Corn, Oats, and Rye, while Wheat and Wheat Flour closed more firmly. Oats have been very scarce, particularly old. The export inquiry for Wheat, Corn, and shipping grades of Flour, has been brisk at the current quotations. Provisions have been more sought after at generally higher prices. Pork and Lard have been pur-

chased freely on speculative account, at advanced figures, closing, however, quite depressed. ... Cotton has been in good request, but unsettled in price. ... A fairly active inquiry prevailed for Wool, at full rates, and a lively demand for Tobacco, the latter largely on speculation, at improved prices. ... Hops closed up more firmly, on a somewhat better trade and speculative call for supplies. ... Hay, Straw, and Seeds quiet.

New York Live-Stock Markets.

WEEK ENDING	RECEIPTS.					
	Beeves.	Cows.	Calves.	Sheep.	Swine.	To'l.
July 20.....	11,193	98	3,055	27,233	23,061	64,675
July 27.....	7,054	117	2,996	24,902	22,213	57,272
Aug. 3.....	8,781	85	2,264	25,059	22,672	58,861
Aug. 10.....	10,010	83	2,201	26,917	26,375	65,616
Total for 4 Weeks.	37,068	383	10,516	104,116	91,311	246,424
do. for prev. 4 Weeks.	36,599	231	12,960	88,225	115,103	251,118
	Beeves.	Cows.	Calves.	Sheep.	Swine.	
Average per Week.....	9,267	96	2,634	26,029	23,577	
do. do. last Month....	9,149	58	3,240	21,556	28,775	
do. do. prev's Month....	8,137	60	3,986	15,710	37,835	

Beef Cattle.—The heavy receipts during the first week of the month were more than the market could bear, and at once reduced prices to the lowest rates of the previous month. As usual, the poorest grades of stock suffered most, and dealers were glad to realize without losing more than \$100 a carload. It was not that prices were too low here, but too high in the West; the expectation of a scarcity, which had led buyers to give high prices for their stock, proved illusive, and a surplus was met instead. A sudden falling off of over 4000 head in the next week, helped matters, and brought about a temporary recovery of ½ a cent, but this was soon lost, and the poverty of the stock brought in was a dead weight on the market, too great to be carried. To ship stock which sells here at \$25 to \$30 a head, is a waste of time and money, and the effect is to lower the tone of the whole market. Thus the market closed dull and irregular, with a wide range. Poor Texans sold for 6½@7c., and the best, which were not good, for 9½c. *q* *h*. Ordinary cattle sold from 11@12½c. *q* *h*., to dress 56 to 58 lbs. *q* *h*. Extra brought 12½@13c., to dress 58 lbs.

The prices for the past four weeks were as follows:

WEEK ENDING	Range.	Large Sales.	Aver.
July 20.....	7 @12½c.	10½@11c.	10½c.
July 27.....	8 @13c.	10½@11½c.	11c.
Aug. 3.....	8½@13c.	11 @11½c.	11½c.
Aug. 10.....	7 @13c.	10½@11½c.	11c.

Milk Cows.—There has been a moderate demand for cows, and only a fair supply. The market has been dull, and dealers have held off for full prices. At the close common to choice cows, and calf, were held at \$40@57½ a head. **Calves.**—The market for calves of all sorts has been steady and without change. At the close the demand is fair. 6½@9½c. *q* *h*. was paid for poor to prime milk-fed veals; 4@6c. *q* *h*. for buttermilk calves, and \$7@10 per head for grassers. **Sheep and Lambs.**—There is nothing to note in regard to sheep or lambs. The market closes with fair demand for good stock, but easy as to poor. Sheep were selling at 4½@6½c. *q* *h*. for poor to prime, and lambs at 6@8½c. *q* *h*. **Swine.**—There have been no live hogs offered for sale the past month. All have been consigned direct to slaughterers. Dressed hogs have been firm up to the close of the month, when they became weak and fell off a fraction, selling at 8½@9½c. *q* *h*., for rough grass-fed, and 8½@9c. for corn-fed. The arrivals for July were 98,616, with an average price of 9@9½c.; for the same month of the previous year the arrivals were 132,497, with an average price of 6½@7½c.

Recent Sales of Shorthorn Stock.

—The sale of the stock of Messrs. Hughes & Richardson, of Lexington, Ky., on July 22d, realized \$51,265 for 86 head, an average of \$730 each for 63 cows and heifers, and of \$228.26 for 23 bulls and 6 calves. The highest price was \$2,150 for a cow, "Lady Bates. Several yearling and younger hulls of good blood, were sold for \$75 to \$150. The joint sale of E. L. Davison, Wm. Warfield, J. G. Kinnard, and some other breeders, of 111 animals, held at the farm of Mr. Warfield, realized \$31,560, an average of \$306 for cows and heifers, and of \$170 for bulls of all ages. At the sale of Messrs. Leney's herd, at Wateringbury, England, 41 head were sold at an average of \$1,143 for cows and heifers, and \$336 for bulls. The highest price paid at the sale was for a calf, "4th Grand Duchess of Geneva" a grand daughter of the "7th Duchess of Geneva," which was bred by Mr. Sheldon, of Geneva, and was imported into England from the United States in 1867. The calf brought 2,000 guineas or \$10,400. At Messrs. Abram & Van Meter's sale, in Clark Co., Ky., 69 head were sold for \$36,830, an average of \$618.25 for females, and \$132.50 for bulls. At Warnock & McGibben's sale, July 28, 78 head brought \$35,690, average for females \$519.40, for bulls \$148.46. It is worthy of notice, that on the whole those animals sold, that were purchased at the New York Mills sale last year, brought prices in advance of their cost. It is safe to conclude from this fact that prices are still advancing.



containing a great variety of items, including many good hints and suggestions which we throw into smaller type and condensed form, for want of space elsewhere.

Remitting Money: — Checks on New York City Banks or Bankers are best for large sums: make payable to the order of Orange Judd Company. Post-Office Money Orders for \$50 or less, are cheap and safe also. When these are not obtainable, register letters, affixing stamps for postage and registry; put in the money and seal the letter in the presence of the postmaster, and take his receipt for it. Money sent in the above three methods is safe against loss.

N.B.—The New Postage Law.—On account of the new postal law, which requires pre-payment of postage by the publishers, after January 1st, 1875, each subscriber, whose subscription runs over into the next year, must remit, in addition to the regular rates, one cent for each month over which his subscription extends in 1875, or ten cents for the whole year 1875. Every subscriber, whether coming singly, or in clubs at club rates, will be particular to send to this office postage as above, that is, at the rate of ten cents for the year, additional to the regular subscription. Subscribers in British America will continue to send postage as heretofore, for pre-payment here.

Bound Copies of Volume Thirty-two are now ready. Price, \$2, at our office; or \$2.50 each, if sent by mail. Any of the last seventeen volumes (16 to 32) will also be forwarded at same price. Sets of numbers sent to our office will be neatly bound in our regular style, at 75 cents per vol. (50 cents extra, if returned by mail.) Missing numbers supplied at 12 cents each.

Our Western Office.—Our friends in the West are reminded that we have an office at Lakeside Building, Chicago, Ill., in charge of Mr. W. H. Busbey. Subscriptions to *American Agriculturist* are taken there, and sample copies of the paper and chromo are delivered, and orders received for advertising on the same terms as in New York. All our books are on sale at the Western Office. Please call and examine, buy, subscribe, and advertise.

Our Fair List.—We publish according to usage a list of the forthcoming fairs, which will be found upon pages 353 and 354. The Secretaries of the various societies have favored us with official announcements to a greater extent than usual, and in addition to the data thus given, others are taken from the numerous exchanges that come to our office. Every possible pains is taken to make the list as correct as possible. It sometimes happens that the date first fixed upon for holding a fair will be changed, either on account of the season, for the sake of not conflicting with some other fair, or for other reason. Several cases of this kind happened last year in which we were not informed of the change. Discrepancies produced by such causes it is impossible to avoid. We give the most reliable data we can find, and have no doubt that the present list will be found the most complete that has yet been published.

Cornell University has at length fully organized its College of Agriculture, as will be seen by our advertising columns. Several of the professors in this department are personally known to us, as men eminently proficient in their specialties. The University is located at Ithaca, a flourishing town in Central New York, in the midst of the most delightful scenery.

A Railway Gazetteer.—While a Railway Guide is useful for some purposes, it is very unsatisfactory if one wishes to know upon what line any particular town or village is situated. The "Gazetteer of Railway Stations," published by the National Railway Publication Co., Philadelphia, is a most useful little work, as it gives an alphabetical list of all the stations in the United States and Canada, showing what line they are upon, their population, and stating if they have telegraph and express offices. Besides this, there is Wells, Fargo & Co.'s Express Directory, showing how to reach all points in the Pacific and far Western States, together with much other useful information. Price, \$4.

The Death of John Staunton Gould occurred at his residence in Hudson, N. Y., on August 8th. He died of congestion of the lungs, and was



15
MONTHS
FOR A YEAR.
SUBSCRIBE
NOW
FOR THE
AMERICAN
AGRICULTURIST.
READ THIS
AND TELL
EVERYBODY
ABOUT OUR
SPECIAL OFFER
For 1875.

TO WIT:

Every Subscriber in September, 1874, to the *American Agriculturist* for 1875, (that is for Vol. XXXIV complete,) will be entered on our books at once, and receive the paper the rest of this year (3 months) without extra charge.

N. B.—This applies to all new Subscribers, whether singly at \$1.50 a year, or in clubs of four at \$1.25 each, or in clubs of ten at \$1.20 each, or in clubs of twenty or more at \$1 each. Ten cents extra must be sent with each subscription for pre-payment of postage for the year 1875.

Every Subscriber who remits an additional 25 cts., to pay for mounting, packing, and postage, will receive, pre-paid, the beautiful Chromo

"UP FOR REPAIRS."

The above offer will expire on September 30th. Let us hear from thousands who will take this Journal fifteen months for a year's price.

63 years of age. In early life Mr. Gould took an active part in politics, but for many years he has devoted himself to improved agriculture. As President of the N. Y. State Agricultural Society, and as lecturer on Mechanics as Applied to Agriculture, in Cornell University, he was thoroughly identified with agricultural pursuits. His genial manner made a favorable impression upon all who came in contact with him, and his cautiousness and careful judgment gave his opinions great weight. The State Society and Cornell University have lost a working member, and agriculture a most zealous promoter.

The Death of Henry Stephens, the author of the "Book of the Farm," took place at his residence, near Edinburgh, early in July last. He was in the 80th year of his age, and only three years before his death he completely revised and largely re-wrote his Book of the Farm, which is on all hands admitted to be the best practical work on British Agriculture, and which has furnished the materials for not a few English and some American writers on agriculture.

Perennial Phloxes.—These plants are gradually working their way into popular favor. There are now fine varieties from white to scarlet and crimson, but we have not seen so pure a white as is shown in the flowers of a seedling raised by Mr. White, of Jersey Heights, (Jersey City), N. J. The plant is very dwarf, truss large, and the flowers without any tinge of green. Mr. W. said he had no name for it, and we suggested White's White, which if it were pronounced "whitest white," would not be a misnomer.

Mr. F. R. Elliott has removed from Cleveland, O., to New York, office 53 Duane st., where he offers his services as landscape gardener and consulting horticulturist. While we have had occasion to differ from Mr. Elliott in some matters, we have never had any doubt as to his ability, and feel quite sure that from his long experience, he is capable of giving satisfaction to those who may wish his services.

Comfortable Country Chairs.—The chairs illustrated last month, page 305, were noticed on their own merits; we have since learned that they were made by A. E. Cooper, of Cooper's Plains, N. Y., whose catalogue shows that he makes a great variety of such wares.

The Submerged Pump.—Having occasion to put a pump into a well this spring, and finding that several neighbors, who were using the Submerged, gave a good account, we fixed upon this style of pump. It is very simple in construction, works easily, and answers admirably as a force-pump. The pump itself being under water it cannot possibly freeze, nor is there ever any annoyance from its getting dry. Thus far we are quite satisfied with its operation.

Weigh and Measure Everything.—Now that the season for selling has arrived, we would impress upon our readers the necessity for accurately weighing and measuring everything they sell. There is too much guess-work done. Buyers are handling produce every day of the year, and they weigh and measure all they handle. They are well posted. Farmers are not. When it comes to estimate the farmers are beat. "It is naught, it is naught, saith the buyer." And farmers are too easily persuaded by his pertinacity. Besides, farmers want the money and do not like to lose a sale. So they give way. There is no settler of disputes so stubborn as a good platform scale. A Fairbanks' scale will save many words, and much time and loss. Every barn should be provided with one, and nothing should be taken out for sale until it is weighed and plainly marked with its weight.

Butchers' Offal.—"D. B.," Champaign, Ill. Butchers' offal should be composted with earth in layers of a foot of each, and the pile well covered with earth. In this condition it should remain for a few weeks, when the pile may be turned over or mixed and spread at once, to be plowed lightly under the surface.

Crops in Kansas.—We have received from Alfred Gray, Topeka, Secretary of the State Board of Agriculture, a copy of the reports made by County Agricultural Societies, to the State Board of Agriculture of Kansas, of the acreage and condition of crops up to the first of July last. From these it appears that the acreage of almost every crop is considerably larger than last year, while the average condition is generally better than last year, wheat being the most remarkable exception. The value of these reports is greatly enhanced by their promptness, and if the State and local societies elsewhere, would emulate the example of the Kansas associations, and take pains to make correct reports, the

service to the farmers of the whole country would be of great value. Reports now of last year's crop, are about as useful as a last year's almanac. They are as plentiful as they are useless. These reports from Kansas are the first we have seen of the present crop, except general estimates not pretending to accuracy.

"Lump upon a Mare."—"J. G.," Preston Co., W. Va. A swelling upon the abdomen, near the udder, of a mare, which has recently foaled, may be due to several causes. It may be the result of inflammation of the udder, or what is known as "mammitis," or it may be caused by an injury in getting over a fence. In either case it would be safe to bathe it with cold water.

Lime upon Wheat.—"J. T. G.," Lafayette, Va. Lime is rarely used in less quantities than 15 to 40 bushels per acre. Any quantity that could be sown with a guano attachment to a drill would be too small an application to have any effect. One of the useful effects of lime is its mechanical operation upon the soil, and another is its chemical action upon the vegetable matter contained in the soil, and for either of these effects to be made apparent, at least 15 bushels per acre should be used.

Ice-Houses and Milk-Rooms.—The numerous inquiries for a connected ice-chamber and milk-room are not unnoticed. Press of other matter so far has forced their postponement.

Sowing Guano or Plaster.—"D. B.," Champaign, Ill. Guano or plaster may be sown broadcast by a Seymour's broadcast sower, which sows evenly from 25 pounds to 1,000 pounds per acre. It is disagreeable to sow either of these fertilizers by hand.

Application of Superphosphate.—"C. F. W.," Shufordville, N. Y. We have found the best method of applying superphosphate to the wheat crop to be to sow half the quantity, or 150 lbs. with the seed in the fall, and the other half in spring, as soon as growth commences. For spring crops it should be sown with the seed, and as near to it as possible.

Wistaria.—"A. M. P.," Norwich, N. Y. In localities too severe for the Wistaria, it should be laid upon the ground and covered with a few inches of earth. If it is necessary to do this, care should be taken in summer that the stems do not get so entangled with the trellis as to make removal difficult. If the Chinese is not hardy, why not grow the American?

Sunflowers.—"Alabama," we have not the slightest faith in the story that sunflowers will prevent "chills and fever." The leaves of this plant can do no more than any other foliage in purifying the air, and where this disease prevails, there is usually foliage in plenty. This sunflower matter is an old story. The latest thing is the Eucalyptus, or blue gum, which is said to be a sure cure. We have no more faith in this than in the sunflower, and singularly enough, its anti-malarious properties are not known in its native Australia.

Paris Green.—"J. H. F.," Monroe Co., Pa. Paris Green is not soluble in water, it is only suspended. It may be applied by a watering pot, stirring it as often as it settles, or by means of a whisk broom.

Seed Rye.—"H. C. M.," Roekland Co., N. Y. You can procure excellent seed rye of R. H. Allen & Co., 189 Water St., N. Y. It is grown by William Crozier, of Northport, Long Island.

Weed Named.—"Farmer," Westford, Vt. The specimens sent is the Rough Corn-flower, *Rudbeckia hirta*, a plant which a few years ago was rare in the Eastern States, but which is now unfortunately becoming too common. We know of no specific treatment for this or any other weeds, except good cultivation. One thing should be done at once—cut the tops and prevent its spreading by seed.

Rabbits.—"E. A. T.," Pa. We have not much faith in the profitableness of rabbits—that is, to sell as food. The wild rabbits, or hares, are offered in the markets at a very low price, and meet with but slow sale. We are not a rabbit-eating people.

Hydrangea.—"D. T. Ness. The flower of *Hydrangea Hortensia* frequently comes blue, like the specimen you send. Gardeners endeavor to produce this color by the use of peat, iron, and other applications, but it often appears without any special treatment.

Cider Mills.—"H. T. E.," Belleville, N. J. The price of a good portable cider mill, such as the "Keystone," or the "Buckeye," or some others, which

are to be found described in our advertising columns, is from \$10 up to \$40 or \$50, according to size. The cheapest is a size suitable for small orchards.

Iron Hurdles.—"T. G.," Kittrels, N. C. We do not know of any maker of iron hurdles. If there are any such, possibly your inquiry may attract the notice of the parties.

Virginia State Agricultural Society.—This association offers premiums of various values, from \$50 downward, for essays upon such practical subjects as the following: on the best management of a farm of 150 acres, devoted to mixed farming; separate essays for different districts requiring different treatment, being called for; on the best management of various crops; on grasses adapted to Virginia; on swine; on cattle, etc.; for the best experiments in the cultivation of various crops, and in the use of fertilizers. We could suggest only one addition to such an excellent list, which is a premium for the best managed and cultivated farm. To see and examine the best managed farm in any district, would be worth a world of written description.

SUNDRY HUMBUGS.—In former months we have had occasion to notice the fluctuating character of the "humbug business." At some seasons we are overrun with complaints of old and new schemes, and at loss to which to give prominence; then again there seems to be very little activity among the swindlers. The present is one of those seasons of quiet. These fellows find the greater number of their victims among the rural population, and they no doubt are aware that in hay and harvest time the farmer and his family are too busy to read their persuasive documents. So these schemers of all kinds during the summer keep very quiet. The successful ones, and some of them are very successful in money-making—especially the quack doctors—may be found at the watering places, cutting a dash with their splendid horses and costlier carriages, and vieing with the gamblers in making a vulgar display of diamonds.

WALL STREET.

Some chaps advertise that money invested by them in stocks and gold, pays 200 per cent a month, and strange to say, apparently sensible people believe this, and ask us if it will be safe to invest in the hands of the advertisers. Safe! bless your heart, yes, so safe that mortal eye will never see it again. One of these inquirers writes that he wishes to invest \$10—let him do so by all means, it will not be paying very dearly for a lesson. If this correspondent really thinks that any business which pays 200 per cent. monthly, needs to advertise for customers, he can afford to pay \$10 to be taught better. He says, "tell us all you know about the Bankers and Brokers of New-York city." We have had some funny requests in our day, but this is the funniest. Still we can reply briefly. There are bankers and brokers even in Wall street, who are men of the highest honor, and who would lose their right hand, before they would do a mean thing. This class do not hold out ridiculous inducements to their patrons. Then there are those who call themselves bankers and brokers, who will do anything to make a dollar, and we be to the man who gets into their hands. We do not claim to have an acquaintance with this style of brokers, but it comes in our way now and then, to know something of their operations. About a year ago a gentleman, who had in successful business in a Western city accumulated what he thought was a handsome competence, came to New York to live at his ease; he became interested in Wall-st., and thinking that he might as well increase his moderate fortune, placed his available means in the hands of one of these brokers. He was kept along with reports of enough successes, to encourage him, and the speculations continued all winter. When he came to square accounts with his broker, \$5 was all that he had left. Our friend turned his face westward, quite convinced that he had seen enough of Wall street. Now, if a man of fair business talent, and who, being upon the spot, could watch matters daily, fared so poorly, what sort of chance has one who lives at a distance, and knows nothing of the tricks of the street, if he puts his money in the hands of a curbstone-shyster? If one has money, be it only \$10, he is quite right in trying to invest that sum in such a manner as will increase it, but he may be quite sure that the way not to do it, is to trust it to the tender mercies of sharpers calling themselves brokers.... Complaints still come with regard to dealers in

CHEAP SEWING MACHINES.

We have said all that need be upon this subject. We repeat that there is no help, so far as we are aware, for those who have sent money, and received no returns. It is impossible for us to comply with the request of those who ask us to investigate their cases. We could not possibly give the time to the matter, even if it would do any good. The chaps need only say that no money had been received from the complaining party, and that would be

the end of it. The only machine of this make now most advertised, that we have seen, is a very funny affair, a very burlesque on machinery; the parties advertising are, or were a short time ago, in a very obscure upper room, without any sign to indicate their whereabouts. The look of the affair is suspicious, and the complaints that we have had are so numerous, that we feel it a duty to warn our readers against sending money to any unknown parties, who offer cheap sewing machines.

THE C. O. D. SUPPLY CO.

is still operating, apparently devoting itself especially to the Southern States. Let them alone, there is altogether too much machinery about it, and there is great danger that you will get your fingers pinched. . . . Our correspondent C. T. S., in West Va., can not have long been a reader of the *Agriculturist*, or he would not have asked us to get his prize from the

METROPOLITAN PRIZE ASSOCIATION.

We could not think of it. What these people want, is your \$7.50, and then you may get your \$250 melodeon—and then again you may not—probably not. Our correspondent evidently fears that he may run some risk in sending his money, so he writes to ask us to get his prize. No, we thank you. . . . Here is a correspondent in Tennessee, who asks us if our laws can not stop these Prize Associations. Certainly. We have laws enough, and upright judges, but laws do not put themselves in operation; there must be complaint and proof of wrong doing, in order to convict. On account of the fact that the victims of city swindlers reside at a distance, these evil-doers stand in little fear of the law. If one who lives in a distant State, merely asserts that he has been swindled by some one in New York, the law can do nothing. The only thing that has any effect upon these fraudulent schemes, is the exposure that the *Agriculturist* has given them these many years, and in which it has had but scant assistance from other papers. Were every paper, agricultural or otherwise, to refuse all doubtful advertisements, and to keep their readers warned against all suspicious schemes, the occupation of the whole horde of these swindlers would be at an end.

IN THE "MEDICAL" LINE.

The advertising dodges of these quack-medicine fellows are numerous, and some of them ingenious; thus there is one in Buffalo, who advertises that he will send a "prize-picture" free. "An ingenious gem, 50 objects to find." Many a hoy or girl will invest a stamp for the sake of getting a puzzle-picture—or a picture of any kind. In return they get a card with a very poor puzzle-picture upon one side, and upon the other side an advertisement of a book on sexual matters, which will be "sent secure, post-paid, for 10 cents." The hook is like all of its class, intended to work upon the imagination, and excite the fears of the young—and then it follows as a matter of course, that the only safety of the reader lies in placing himself in the hands of this wonderful Abbey, at \$10 per month. He is a high old fellow, this Abbey—as he says, "none living know my present remedy." What would become of the world, if this Abbey should die?—His precious pamphlet goes into our collection of curiosities. Don't take the road leading to that "Toll-Gate." . . . They get the news slowly out in Wisconsin, for here is one at this late day, who asks about

OLD MOTHER NOBLE.

It is so long since that we heard of the dear old "critter," that she had quite gone out of mind. Our correspondent can find "what we think of" Old Mother N. by consulting these columns for two years back, but a particularly touching account of *him* is given in December last. He was last known as Dr. Clark Johnson, Edwin Eastman, and the rest of her. . . . Then here is another from a Kentucky friend, who thinks we ought to expose

UNCLE BEN JO'S BELL-TONGUE SYRUP.

This is also an old affair. It seems a waste of good space to devote it to such shallow nonsense. We have already given all needed attention to this particular humbug. If there is any live mortal who can read, who will believe the statements put forth in this pamphlet, nothing that we can say will prevent him from being a victim. We are sorry for the "poor, susceptible farmers," hut what can we do other than to caution them against all such things. If a "subscriber to the *Agriculturist*" is, as you state, an agent for this quackery, we are sorry, but there is no knowing how much worse he might have done, had he not taken the *Agriculturist*.

INSTITUTES AND UNIVERSITIES.

We must again repeat what we have said so often, that there is no such thing, properly speaking, as the "N. Y. Medical University." One or more quacks choose to adopt this title, to aid the sale of their preposterous medicines. We suppose that the Attorney General of the State could prevent them from using this title, but he has not seen fit to do so. No proper medical college—there can be no such thing as "medical university"—ever makes or sells medicines, nor does any such institution

ever advertise cures. Colleges and universities are educational institutions, and not medicine shops. So with these so-called medical "Institutes," they are generally run by quacks of the most dangerous kind. The recent death of a young lady in one of these "Institutes" in New York, may lead to an overhauling of the whole crew.

THE OLD, OLD DODGE,

is now being played by one Daniel Adee. It is the "Preacher of the Gospel," or "retired missionary" dodge. D. A.'s oldest son gets dead-sick with consumption—something wonderful cured him, and the prescription can be had by addressing Dan—as aforesaid. It is so kind of Dan, to offer the prescription, and to generously pay for advertising that he will do so! One of our friends sent for the prescription, just to see if it was as we predicted. Dan Adee had a son restored by the "Indian Cough Plant," the same thing that cured the son of Dr. Brant, who was missionary to the Blackfoot Indians, and he learned all about it from a squaw! All you have to do is to get the stuff known to the "native Indians" (who ever saw any other?) as "Indian Cough Plant," steep it in water, and take it. But those poor, "miserable unfortunates," what don't have no correspondents among the Injuns with dark colored pedal extremities, can get the extract, for \$2 a bottle, from this dear benevolent "Minister of the Gospel"—or what is the same thing, Mr. D. Adee. Daniel, this is old unto staleness—it is malodorons. Step aside, and let

"DOCT." WHITE AND HIS CURATIVE SYRUP

come to the front. Now here is something worthy of the genius of Huyler, even the narrative of dear Eddie Eastman, thrilling as it is, is hardly so ingenious as the story of how White came by his Curative Syrup. We wish we had room for the whole, but can make only an abstract. The old man White having "educated" his son, sent him out with "large sums of money," to discover "hidden secrets relating to medicine." We shouldn't like to be a medical secret with White, Jr., after us, not much. He "did" the Indian tribes of this country, but nary a secret could he find. Then he went for the "wise men of the East," whoever they may be, and there he learned that the Jesuits received regularly from South America a medicine possessing wonderful properties, and that it came from Rio Janeiro. Nothing easier than for young White to "up and dust" and "git" for Rio. Here he learned that an "aged monk from the mountains" made regular shipments to "the Jesuits in the East." What was easier than for White to lay low for this monk, to follow him to his cave in the mountains. And then—ah White, it was a little mean—to get up into a tree and watch how the old fellow did it. And then he gives a picture of the monk's laboratory, which should convince the most sceptical. The monk was so indiscreet as to have his formula upon "a paper pasted on a board," and when he had stopped work for the night, what was easier than for White to copy off this paper "by the light of the moon"—in Latin at that—and to "git" once more. Rather hard on the monk, but the end justified the means. When he reached home, the senior White was just breathing his last, hut junior White, who had driven up in a "beautiful coach," with a "fine span of horses"—how touching all these little particulars are—soon put a stop to the old man's troubles, and cured him at once. If you don't believe it, there is a picture of the old man White reading the Bible; old mother W. sitting as straight as if she had swallowed a ram-rod; then young Doctor White—the chap who choused the monk out of his secret, and his wife—and, oh! the children—well the chap ought to make something out of his syrup, to find bread and shoes for all these little Whites—and so near of a size, too. Take this White's Curative Syrup thing altogether, it is a little the steepest piece of quackery we have seen in a long time. Somehow we can't help thinking that the hand which did Ned Eastman's narrative, had to do with this. Is it possible that this country can boast of two such?

THE COUNTERFEIT MONEY OR "QUEER"

business is duller than we have ever before known it. One P. A. Schneider, at Allentown, Pa., who claims to be agent for "the New York Co.," sends out about the richest specimen of a circular, that we have seen. Either this Schneider is an ignorant ass, or he assumes to be simple and stupid, with the hope that some who think themselves smart, will catch at the bait. We incline to the last view of the case. Here is a specimen of his circular: "I have no counterfeit money. I have rail jimine goods money I was 10. years in the United State printing Office in that tim I did slib a few blades, and now I make my own goods in my own printing office—if you dond trust me then Come in Town & C ME."—That, Mr. Schneider, is just "a little too thin."

A Monstrous *Lilium auratum*.—The "monstrous" forms of the common Japan lily (*L. speciosum*) are well known, as the habit has become so fixed, that bulbs producing monstrous stems are offered

for sale. We never saw a monstrous Gold-handed Lily (*L. auratum*) until Messrs. J. M. Thorburn & Co., recently sent us a specimen. In this, as in the others, the stem is several inches broad, and flattened as if what should be several stems, were soldered together, and the upper portion of it is clothed with flowers as closely as can be packed. By counting a portion, we estimate that this stem produced considerably over a hundred medium sized blooms, and is altogether one of the most wonderful specimens of floral abundance that we have seen.

The Colorado Potato Beetle in

New Jersey.—Just as we go to press, there comes the startling announcement that the dreadful "potato bug," has at last made its way to the coast. It has been found near Elizabeth, and in the Saddle River township, N. J. Coming so late in the season, it can do but little damage to the present crop, but next year farmers will have work to do. Let New Jersey look out!

Eastman's Business College.

—This establishment, which not many years ago began in a ridiculously small way, now has some 1600 students, 60 instructors, and occupies several large buildings in the beautiful city of Poughkeepsie, N. Y. A directory, giving the present residence and occupation of the graduates of this college, shows that the young men are making their way in the world. Circulars can be had by addressing the President, H. G. Eastman, Poughkeepsie, N. Y.

New Raspberries.

—Several new raspberries have been brought this season for our inspection. The only one of these of any promise, was a variety brought by Mr. Saunderson, of Staten Island, which had excellent qualities for a market berry, it being of good size, bright color, and, what is of most importance, great firmness.

Wild Carrots.

—"J. L. W.," Thomasville, N. C. It is true that the Wild Carrot does not spread by the root, but it produces an abundance of seed to continue the crop. The plant should not be allowed to perfect its seed.

Spreading Lime.

—"H. H. F.," Lavansville, Pa. Lime can not be spread as it comes from the kiln, it must first be slacked. Then the easiest and cheapest method is to spread it with long handled shovels either direct from the heaps, or from the box of a low sled.

Blackberries.

—"J. B. D." says: "On p. 283, speaking of the cultivation of blackberries, you direct the new canes to be pinched off at the height of five or six feet. Having tried various heights, I have found that my berries are largest and most abundant when the canes are cut back to within three or four feet of the ground."—Our correspondent does not say what varieties he has kept at this height. In restricting the plants in this manner, we should fear that they might be forced into flower unseasonably.

The White Willow.

—"L. L.," Hutchinson, Kansas. The white willow is almost universally well spoken of through the West, as a rapid grower, and a useful tree, both for shelter and for hedges. A great many persons are planting it, and we have seen trees from cuttings, planted three years ago, which were three inches thick, and fifteen feet high. Those trees may be cut this year, or next, for fence-poles. There are also many willow hedges planted, and if they are not all that may be desired, yet they grow quickly, and make a good wind-break; when three or four inches thick they may be lopped off at four feet from the ground, to furnish poles for rails. The cuttings should be thicker and larger than usually planted. An inch in diameter at least and four feet long, is a good size. They should be set a foot apart, and eighteen inches deep.

Onion Grub.

—J. B. Duffey, N. J., writes: "Three times in my somewhat limited experience I have been visited by the onion grub, the ravages of which, on each occasion, threatened the entire destruction of my beds. It was suggested to me to use soot, sprinkling it along the rows. I did so, and the effect was almost magical. My onions immediately ceased wilting, and an examination of the plants a day or two after the application showed no trace of the grub. The remedy never failed me, and besides, it acted as a vigorous fertilizer to the crop."

Wheat and Guano Drill.

—"P. N.," Clinton Co., Ill. All the drills made for sowing grain have attachments for sowing fine fertilizers along with the seed. But there is no drill made that sows lime in such a manner. Lime always contains hard lumps, which render such a method of sowing impracticable.

Stopping Leaks in a Roof.—Montclair. When a shingle roof becomes worn and leaky, the cheapest plan in the end is to have a new roof. There are a variety of roof paints which will make a temporary repair, but the contraction and expansion by heat and moisture, will soon open the cracks again, and the roof will be as leaky as before it was painted.

Spaying Heifers or Cows.—"R. M." Both heifers and cows are sometimes spayed. The former are thus made to grow to a larger size for beef, and the latter are made to give milk for several years without intermission. Spaying cows is useful, when milk is desired regularly, in places where bulls are not kept, as in cities. The operation should be performed by a veterinary surgeon. It can not be done safely by a person who knows it only from books.

Leaky Cisterns.—"S. H. H.," Tioga Co., N. Y. There is no help for a cistern, at the bottom of which there is a spring of water. The water will break through in spite of all one can do, in most cases if not in all. We would abandon such a cistern rather than be bothered with it, and try another place.

Fodder Crops for the South.—Alabama. Cat-tail millet is one of the many varieties of what is known as Hungarian grass (*Setaria Germanica*, botanically). It is an excellent fodder crop for the South. The Southern pea is a good fodder crop. Oats and rye may be sown for winter feed. Barley and vetches sown together are also an excellent fodder crop. With these and corn, beets, cabbage, and rape, a succession of fodder crops might be had throughout the season.

Irrigating Corn or Cotton.—Alabama. It would undoubtedly pay to water both corn and cotton during drouths, if the water can be procured without expense. But it is useless to water crops during the day time, and under a hot sun. The water should be applied during the evening or in the night. The cheapest method would be to turn the water from a stream directly into furrows between the rows if this is possible. Watering by means of sprinklers upon wheels, might be used while the crop is small, but it would be slow and costly. If a width of 6 feet is watered at one passage through the rows, every mile travelled would water three quarters of an acre. It is a question altogether of the cost of procuring the water.

A Gorged Cow.—"J. H. F.," Canadensis, Pa. When a cow has been carelessly allowed to gorge herself with dry meal, the safest remedy is to withhold water, except in small quantities, to give a pint of linseed oil, by the mouth, and injections of soap and water, until the bowels are evacuated. No food should be given until the stomach and bowels are freed.

The American Poultry Pedigree Book.—We have a sample sheet of the forthcoming "American Pedigree Poultry Book." We have already expressed our opinion of this book. The "American Swine Herd-book," failed to become a fact, from its obvious impossibility. But a poultry pedigree book is more impossible still, if we may use such a term; it is an absurdity that we could hardly suppose would be entertained. To what vast proportions it must arrive in two or three years, if it is generally used; and if it is not generally used, it becomes worthless. The impossibility of identifying any bird, and the confusion which exists from the beginning, will certainly lead to frauds which cannot be detected, and there will be no confidence in it. And then there will be complaining and trouble.

Clipping the Toes of a Cow.—"R. M.," Salt Lake City. When the hoof of a cow, ox, or sheep, grows too long at the toe, it may be shortened by taking a pair of strong pincers, such as are used by blacksmiths for horse-shoeing, grinding the edges sharp, and cutting away the toes, until they are reduced to a proper shape. Or a strong paring knife may be used if handled with care, but it is not nearly so safe as the pincers. Animals with feet too long at the toe, should be attended to at once, or lameness may result.

To Raise a Spring.—"T. L.," Gadsden, Ala. It would not answer to build a wall around a spring, in the hope to raise it 12 feet. The water would break out somewhere else. The best plan perhaps would be to put in a hydraulic ram.

Selecting Eggs for Pullets.—A correspondent sends us a slip, containing an article from an English paper upon this subject. It is stated that the position of the air-bubble in the egg will determine the sex of the chicken. There are four illustrations of the forus of the eggs, and the positions of the air-bubble.

Two of them we have studied and compared together. One of these is said to show the kind of egg that "will hatch a lively cockerel," and the other "will hatch a pullet." This is definite; but unfortunately, on comparing the engravings, the shapes of the eggs, and the positions of the air-bubble are exactly the same in both. A similar result has occurred in every case, in which we have closely investigated the statements of those who have pretended to know more of this thing than any other man. The fact is, as yet this question of sex is undetermined, and a long series of observations, scientifically conducted, are needed, instead of vague surmises, and haphazard conclusions, before we can safely determine anything about it.

Permanent Grass.—"J. W. C.," Rockford, Ill. There is no more unanswerable proof that permanent meadows may be established in our climate, than the prairies which have been broken up and changed into corn-fields. For ages these prairies have produced grass, and have supported millions of animals which have grazed upon them, and yet they have increased in fertility during all those years, so that since those ancient pastures have been plowed, they have borne repeated crops of grain year after year. What has been may again be. It is a great benefit to a farm to have a portion of it in permanent grass, and every new prairie farm opened, should have at least one-third of the area reserved from the plow, for pasture only.

Bone-Dust for Wheat.—"A. P.," Peppertown, Ind. We would rather use Peruvian guano for a wheat crop than bone-dust. The bone-dust is only very slowly soluble, and there would be very little effect. 150 to 200 lbs. guano per acre, on the contrary, would have a very good effect upon the wheat. It should be sown with the wheat in the drill, or broadcast, and harrowed in along with the wheat.

Sweet Potatoes for Feed.—"J. M. D.," Pierce Co., Ga. We have never fed sweet potatoes to stock, but should expect them to be more valuable than round potatoes, turnips, or beets.

To Dispose of Straw, Shucks, and Cobs.—"B. F. B.," Uvaldy Co., Texas. We can suggest no way of making up these matters into manure, but by penning cattle upon them; unless it be by scattering them upon the ground, and plowing them under the surface. The latter will probably be the easiest and cheapest method. It is better than not using them at all or burning them.

Bloody Milk.—"Subscriber," Orlando, Ind. Bloody milk is generally caused by a congested state of the lacteal vessels, through which the red coloring matter of the blood, which is called *hematin*, escapes into the milk. Cooling food should be given, and a strong dose of epsom salts, (12 to 16 ounces). The udder should be bathed in cold water freely several times a day.

As to Draining.—"G. G.," Greenville, Ill. Before so costly a work as underdraining a farm is undertaken, it would be well to count the cost. It is well worth the small sum of \$1.50, to have the means of doing this. "Waring's Draining for Profit and Health," can be had for this price, and will give all necessary information as to cost and mode of doing the work.

Top-dressing Meadows.—"W. W. S.," Dutchess Co., N. Y. There is no better season for top-dressing meadows than the present month. Anything in the shape of manure or fertilizers is better than nothing. Well rotted fine manure is the best application that can be made. Next to that is coarse fresh manure, decomposed woods' earth, rotten chip dirt, tanner's waste, or sweepings of village streets. Where refuse from woolen factories, slaughter houses, or city waste of all kinds can be procured, these should be composted with earth from the roadsides, or bottoms of ditches, and lime or wood ashes, and after remaining a month in the heap, they may be spread upon the grass. It is well to harrow up bare spots, and sow some more grass seed upon them. The earlier this can be done the better for the meadow, as the heavier coating of fall growth that can be procured, the safer it will be from injury by frost. Meadows should not be closely pastured at this season.

Charleston Superphosphate.—"J. M. D.," Blackshaw, Ga. The prepared Charleston phosphates will be valuable for cabbages and turnips. These crops are specially improved by manures containing phosphoric acid.

Cutting Corn for Fodder.—"C. T. S.," Nissequogue, L. I. It is possible to cut up corn-

stalks with the ears for fodder. We have done so with a large-sized "Telegraph Fodder-Cutter," run by a two-horse tread-power, as fast as one man could feed the corn. Such fodder, however, should either be steamed or ground in a "Little Giant" mill—an ordinary bark mill would answer the purpose very well—to prevent much of the corn passing away whole and undigested.

Sugar from Beets.—"A Reader." The manufacture of sugar from beets needs some delicate chemical processes to get rid of the salts, which interfere with the extraction of the sugar. It is this difficulty which has hitherto caused many failures in beet sugar making, and in a small way it would prohibit the domestic manufacture altogether. For sweets for home use, that can be produced upon the farm, there is nothing better than syrup from sorghum. This can be made in a small way as easily as maple sugar.

Breaking Hedge Rows.—"H. E. Van D.," Geneva, Kansas, recommends hedge rows to be broken in June if possible, but not later than July 15th. The rows he broke in August, 1873, were so tough the past spring that the hedge could not be planted. The rows should also be 12 feet wide in place of 6 feet.

Sweet Potatoes.—"W. H. L.," Moberly, Mo. In all Northern localities sweet potatoes require artificial heat to carry them safely through the winter. They should not be exposed to a temperature below 60°, and those who grow them in large quantities have a house for the purpose, in which a fire may be built whenever necessary. Small lots can be kept in a box or barrel in the kitchen, or other warm room; we have known them to keep in an unusually warm and dry cellar.

Garden Questions.—"H. S.," Brandon, Wis. It will not do good, but hurt, to take away the leaves of cabbages and cauliflowers while they are growing. It is not essential for the forming of cauliflower heads to draw the leaves over the head, but it is well to break down a few leaves when the head is forming, to keep the sun from it. Do not understand your question about "top seed" onions; the other is answered in an article on p. 341. Salsify, or vegetable oyster, will sometimes bloom, as will other root crops, the first year from seed, but the seed from such plants should never be saved.

Seed Wheat.—"B. L.," Clinton Co., Ohio. It is questionable if it would pay to purchase seed wheat from a distance, at double the ordinary market price or even less than that, unless in a very small quantity and for an experiment. It is not safe to risk one's whole crop, by changing the seed without knowing exactly what you are doing. The finer white wheats require richer soil than the hardier red wheats, and the difference in the market price will not warrant paying much higher for the seed. It is not so much to the seed as to the land, that we are to look for better crops, and by selecting a good sample of ordinary wheat free from weeds, at a few cents above the market price, one may do better than by paying a double or treble price for other seed, the only merit of which may be that it comes from a distance and costs so much. Clean selected seed is worth 25 cents a bushel above the usual market price of the same variety.

Wheat on Corn Stubble.—"W. W.," Millin, Ohio. There are times and places in which sowing winter wheat upon an unplowed corn stubble may be not only permissible, but proper, as the best thing that can be done. The solid bed thus gained for the seed is often an advantage, as is also the time saved. But where the chinch-bug prevails, all the loose corn stubs should be gathered up and burned, as it is in these and other rubbish that this pest harbors and is sheltered through the winter. The clearing up of such rubbish every fall should be done for the purpose of destroying injurious insects, which would prey upon the coming crop.

Cheese Factory at South Bend, Ind.—"W. R.," South Bend, Ind. Factory men are averse to investing their capital in new places, unless under such guarantees that they will be independent of any adverse action by their patrons at any time in the future. Cases have happened in which, after a factory has been built, those supplying milk have professed to be disappointed, and have withheld the milk, leaving the owner of the factory "in a fix." The best plan is for the owners of the cows to subscribe the money and build the factory, and lease it to the factory man. For 400 cows a sum of about \$7 per cow would put up the factory and furnish it. But before it is built, it would be wise to have a competent person to examine the locality, and advise as to the propriety of building the factory. L. B. Arnold, of Rochester, or Gardiner B. Weeks, of Utica, N. Y., would give trustworthy advice upon this point.

Hereford Cattle.—"J. C. E.," Milton, Ohio. The Herefords are the next best beef cattle to the Shorthorns. They are probably superior to these in some districts. They are, however, at present unfashionable, but the time may not be far distant when these or some other race may overshadow the now favorite Shorthorns, just as the Shorthorns displaced the once favorite Longhorns. The Herefords are a pure breed of large bodied white-faced cattle, reddish-brown in color otherwise, which are excellent feeders, with good constitutions, and fine beef producers. They will doubtless be exhibited at your State Fair, and will be found worthy of examination.

Safe Emasculation.—"A. T. J.," South Bend, Ind. If the cut in the scrotum is made low down, so that any pus that is formed can escape, the operation of castrating is made much safer than if the cut is made higher up. The great danger is from inflammation, the closing of the wound and the formation of pus, which can not escape and is absorbed into the system, poisoning the blood. If the wound is kept open until healed within, the only serious danger is prevented.

How to Recognize a Goose.—"W. N.," Lexington, Ky. It is difficult to distinguish a goose from a gander by external marks without close study. After long acquaintance with the flock, the recognition is very easy. The voice of the gander is harsher and more discordant than that of the goose, the head is coarser, and the bill stouter and heavier, the neck is longer and thicker, and the breast less prominent. Generally the gander is the first aggressor in those demonstrations which a flock of geese delight to make upon strangers. The gander is always on the lookout, and if one in a flock is on the alert, while the rest are feeding, it is almost certain to be a gander.

Harvest Home Celebration.—The Rantoul (Ill.) Association of Patrons of Husbandry held its first harvest home picnic on August 1st in a grove near that town. It was largely attended, and many members of other Granges and industrial associations joined the celebration. There were bands of music, a collation, and speeches, and the experiment was very successful.

Tree Planting in Nebraska.—The Burlington and Missouri Railroad Company has planted along its line of road in Nebraska, for a distance of 120 miles, 500,000 trees. The smallest loss of trees was amongst the ash, of which 98½ per cent lived; of box elder and honey locust, 92 per cent lived; of soft maple 83 per cent; European larch, 82½ per cent; Scotch and Norway pines, 80 per cent; and of several species of willows, 75 to 72 per cent lived.

Small or Large Cobs.—"J. W. J.," Lewis Co., Ky. It is working the wrong way to attempt to reduce the size of the cob in field corn. If the cob could be reduced in size to one inch in diameter by selection of seed for a series of years, the product of the crop must certainly be greatly reduced at the same time. A cob two inches in diameter has double the space to be filled with grain that one half that size has. The effort should be to enlarge the size of the cob in thickness and length, and to increase the length and number of the grains at the same time. There is no doubt that much may be done in this way by selecting for seed those ears which have the largest number of rows and the greatest length, and planting the seed remote from other corn.

Grain Binders.—An automatic binding attachment to a reaper is a very desirable thing to possess. Hitherto the attempts that have been made to effect the binding of the sheaves by machinery attached to the reaper have not been successful. Final success, however, will be attained before long, if it has not already been secured. A binder made by W. A. Woods, of Hoosic Falls, N. Y., was tried recently with success. The sheaves were well bound, without any failures. Another binder, made by N. B. Fassett, has been tried in Iowa. This machine also worked satisfactorily.

Rather Mixed.—A semi-weekly newspaper, with an agricultural department, published in a Western city, states that "land-plaster or guano is the production of a number of rocky islands in the south sea." Also that "a species of land-plaster, which is a deposit of bone-phosphate, is found in South Carolina and Georgia." Then a "Rural" paper, in correcting this statement in describing "plaster," says "that it is not a fertilizer in itself, but absorbs fertilizing properties from the atmosphere;" and further, that "years ago it used to be the practice to roast the rocks, in order to reduce them to powder more easily, and such may yet be the practice where facilities for grinding are not at hand; or where the

rock is impure from hard strata contained in it." How little then must he know about this simple substance, the uses of which for fertilizing purposes and for plastering walls of houses are so mixed together. Burned gypsum is plaster, which, when mixed with water, sets as hard as a stone, and could not in any case be used as a fertilizer. And now a paper, which has "Farmer" for part of its title, recommends grass and turnips to be grown together, and thus raise a double crop.

To Keep Plows Free from Rust.

—"A boy of fourteen," or any other person, does wrong to allow his plows to become so rusty that great labor is required to scour them. There is no help for it in that case, but to scour with a piece of brick and sand and water, until the mould-board is bright. But if, when the plow is done with, the mould-board is covered with thick lime-wash, or a good coating of tallow, and put away in a dry place under cover, there will be no need to spend a whole day in scouring it when it is wanted for use again.

What is a Car Load.

—"R. A.," Ripon, Wis. Generally a car load is ten tons. Specified articles are taken on most railroads in the following quantities as "car loads" viz: salt or lime, 70 bbls; flour, 90 bbls, or 200 sacks; soft wood, 6 cords; cattle, 18 to 20 head; hogs, 50 to 60; sheep, 80 to 100; lumber, 9,000 ft. dry, or 7,000 ft. of green; 17,000 feet of dry siding; 13,000 feet of dry flooring, dressed; 40,000 shingles; wheat 340, corn 300, oats 680, and of barley 400 bushels. Potatoes, bran, feed, and other produce is taken by weight.

Procuring Loans.

—"R. Van D.," Peoria, Ill. Evils always remedy themselves in course of time. The facility of getting loans upon mortgage of Western farms from Eastern capitalists at 10 or 12 per cent. per annum, has been an evil by which the Western farmer has suffered. It has led to loose expenditures and extravagance, and has fastened a load of debt upon the West, which is a dead weight upon its real prosperity. Now Eastern men fear that their debtors might strive to free themselves, by adverse legislation, making foreclosure of their farms difficult or impossible, from their encumbrances, and they have stopped loaning money. We do not know where you could borrow money in any Eastern city, nor would we advise you to try to do it. Borrowing is a bad practice, and only puts off the evil day. The best plank in the Granges' platform is "pay as you go," and your best plan is to become a Patron and hang on to this plank.

Cattle in the South.

—"J. W. J.," Atlanta, Ga. The safest plan to procure hardy improved cattle in the South, would probably be to introduce thoroughbred bulls, a year old, in October or November, from the North, and use them upon the best native cows. If the bull can not stand the change of climate, he will leave some half-bred calves, which might be bred to another young bull. In time a greatly improved stock of thoroughly acclimated cattle would be secured. But there is no reason why cattle from the North should not be acclimated gradually, if care is used. The hot sun in the day-time is not more hurtful than the heavy dews at night, and stock should be protected from both of these. The fall is the proper season for bringing in stock, which then have a whole winter in which to get acclimated. Shelter, fresh feed, and good water, are the requisites for safety.

Treatment of Parrots.

—"An old Subscriber," informs the "Indiana Correspondent," that the proper treatment of parrots consists mainly in giving fresh water every day, proper food with regularity, and keeping the cage clean. Brass wire cages should be avoided. The floor of the cage should be cleaned out every day, and covered with fresh coarse sand and gravel. The perch should be cleaned at the same time. This should be thicker in the middle than at the ends, that the feet may be eased and rested at every change of position. This prevents diseased feet. A deep dish of tepid water should be given each day, to bathe in. Bread and milk should be staple food; the bread should be stale and be soaked in warm water first, and then drained on a cloth, dipped into scalding milk and fed when cold; the bread should not be mashed or soaked until soppy. It should never be given when sour, nor should the feed pan be allowed to become sour. Beech nuts, hickory nuts, walnuts, sweet almonds, crackers without caraway seed, boiled sweet corn, and pieces of sweet apple freed from the skin, are all good if given in moderate quantities. Flesh should never be given, as it engenders a vicious appetite, and causes them to pull and eat their own feathers. Parrots are natives of tropical climates, and need warmth. But they should not be hung up in the foul heated air of a close room—warmed by a hot stove in the winter season—during the day, nor

be left to freeze without fire during cold nights. It is better to place the cage upon a low stand, where the air is pure and moderately warm, in the day, and wrap a blanket around the cage at night. When sick a teaspoonful of hemp seed with a pepper corn or two, should be given every day. Water cress when it can be procured is a good alternative; but these birds are rarely sick, except when they are fed with sugar and other improper food, or when they are neglected.

Low Freights on Grain.

—The current freight on wheat from Chicago to New York is now only 11½ cents per bushel, made up as follows: from Chicago to Buffalo, by steamer 2½c., elevating at Buffalo, ½c., rail from Buffalo to New York, 8c. The tolls on the Erie canal are now 3¼c. a bushel more than the whole freight from Chicago to Buffalo. The cost of handling grain in New York is 3 cents, and the freight to Liverpool is about 14 cents. The cost of carriage from Chicago to Liverpool is therefore less than 28½ cents a bushel. That this is solely due to natural causes, and not in the least to the influence of any combination of farmers, shippers, or carriers, is one of those facts that prove what we have frequently stated, viz., that the prices of all commodities or services are regulated not by laws or combinations of any parties interested, but are the natural effects of supply and demand. Just now there are many unemployed ships upon the lakes, and business generally is dull, hence these unexampled low freights. It is, however, not a healthy condition of things, nor a desirable or profitable one for farmers themselves, when important industrial interests work without profit. And just now the farmer gains no benefit from these low rates, but it goes to those who consume the wheat and flour which he raises. It is fortunate that it does this, for at present there is no laborer so undervalued, or who finds work with such difficulty, as the artisan in the workshops, or the laborer about the streets of towns and cities.

"Walks and Talks" Correspondence.

SELLING THE FARM.—A widow, with three children, who has a farm of 120 acres in Illinois, worth \$75 per acre, writes me that she has carried on the farm for three years, since her husband's death, and has made a fair living, but she and her children have to work very hard. Her friends advise her to sell and put the money on interest. I can give no opinion. It depends somewhat how old the children are, and whether she wishes to keep the farm for them. She gets many things from the farm that she would have to buy if she goes to a village or city. And she now pays no house rent. It is not always easy to sell a farm when you wish. I would go on farming as though I intended to keep the farm, and yet, if an opportunity occurred to sell at its full value, sell, and perhaps buy a smaller farm near a village, where manure and labor can be obtained. Then go into the raising of such crops as require more careful supervision and less hard labor. A woman probably can not compete with the men in raising corn. But she may beat them in raising thoroughbred stock, or in small fruits, or garden stuff. Much will depend on the boys. Every year they will be better able to help.

RAISING CORN.—F. K. Adams, Delafield, Wis., writes me that he breaks up his sod land for corn 4 inches deep. After corn, oats. Then beans, and then spring wheat. The wheat being, I suppose, seeded down. For wheat he plows 8 inches deep. Four inch plowing for corn, and eight inches for wheat, he says, is "not orthodox, but gives me the best results." He cultivates his corn twice, going twice in a row, using a two-horse walking cultivator, and stirring the land six inches deep. As I understand the matter, he cultivates deeper than he plows. Prof. Roberts, of Cornell University, was on my farm a short time ago. He thought I ought to get a two-horse Western corn cultivator, and plow up the land between the rows of corn five or six inches deep. I think one or two such plowings between the rows of corn, early in the season, before the roots have full possession of the soil, would be beneficial, but afterwards I should want to keep down the weeds, and mellow the surface with a shallower cultivator, and one which could be run close to the corn. I am willing to admit, however, that Western farmers can teach us how to raise corn. Mr. Adams says he finds that sod plowed in the fall, and manured in the spring with well rotted manure, and worked in with the cultivator, is best for corn.

DITCHING.—"E. J.," Iowa, asks me in regard to a ditching machine for draining sloughs. I think he will find a sharp spade and a man who knows how to handle it the cheapest and best machine. The tough sod on top may be removed by throwing out a couple of wide, deep furrows. The black mucky soil underneath ought to be easy digging. Get some narrow underdraining spades and a long handled scoop. Keep them ground sharp

and bright. Cut the drain no wider than is necessary for the tiles. In such land, a drain two and a half to three feet deep, 14 inches wide at top and 3 inches at bottom, ought to be cut for from 15 to 20 cents a rod.

ABOUT MUCK.—"W. M." asks if "muck, in conjunction with commercial manures, such as superphosphate, nitrate of soda, etc., would come anywhere near the standard of stable manure as a fertilizer for exhausted land."—I do not think there would be anything gained by mixing superphosphate or nitrate of soda with muck. If you have muck on the farm, or near by, throw it up in the summer to dry. When dry, it can be used in a variety of ways as most convenient—1st, it can be made into a compost with lime or unleached ashes; or (2nd) it can be composted with stable manure; or (3d) it can be drawn at once directly to the field, and spread as top-dressing on grass land. A good superphosphate is a capital manure for turnips. I do not think it will pay on wheat. For barley nitrate of soda and superphosphate, at the rate of 200 lbs. each per acre, will probably pay. The muck will be a slow and lasting manure. The commercial manures we should aim to use only on crops that will pay for their use the first year.

DRAINING A POND.—"W. H.," Kansas, says there is a pond of about three acres on the farm that he proposes to drain. It receives the surface water of about 100 acres. He will dig a drain to the river, about 50 yards long. The bottom of the drain will be loose black soil. He can not get tiles, and asks how he had better make a stone drain. I think I would make a board drain, by nailing, say 6x7 inch boards together A shape. This would be cheaper than a stone drain, and not so likely to sink in the loose earth. But would it not be better to simply make an open ditch for a year or two, until you see how it is going to work, and how large a drain will be required to carry off the water?

Bee Notes.

BY M. QUINBY.

If we compare the amount of honey delivered in New York market 15 years ago with what it is now, we shall find that the present quantity exceeds the former by one half. In the counties in Central New York—perhaps all the counties in this and other States—there are now probably not more than one-fifth the number of bees there were at the time mentioned. We can not explain all the causes that led to these results, but some of them are evident. The bees that are left in the country must be managed differently from what they then were, or the honey would decrease proportionally. Most of the bees left are in the hands of the improved culturists, who supply the market. Consumers are indebted to improvement for their supply. As there is one thousand times as much honey produced in the flowers as is collected, and which must be wasted, of course it is evident that we ought to do all we can to encourage the cultivation of bees by observation and experiment, and by adopting the management of the most successful bee-keepers.

I visited such an one about July 1st; arrived at 4 P. M., and as he was absent, I had an opportunity of inspecting the premises. The house between the bees and street, was on the west side; that and the trees protected them from prevailing winds. The grounds were smooth, and descending just enough to drain off the surface water. On the north side was a close ordinary board fence, two feet from which stood a row of hives, twenty-five in number, six feet apart. Fifteen feet in front was another row, and the same distance apart. There were three rows, all perfectly straight, each hive like every other; each of all—boxes, frames, and combs—was like every other part. The hives were painted four different colors, none of them very dark. Different colors alternated, so that three different colors were between every two of one color. The first time a bee leaves a hive—like a sensible person—it marks its locality to guide its return, and thus avoid entering the wrong hive. When hives are all nearly alike and of one color, they should be set irregularly, and face in different directions.

Five of his hives had swarmed out the day I arrived; all of the swarms had returned after flying a few minutes. Had the hives been close together, and of one color, they might easily have gone into a wrong hive. The queen, unable to fly, moved only a few feet from the hive, and crept back with the bees—the stand being arranged so that she could do this. Knowing pretty well that the old queen would issue with the first swarm, the owner had found and clipped off one wing, to prevent her flying with the bees. They were left without any one to care for them particularly, and there was no fear of their going to the woods. The first move of the bee-keeper, when he got home, was to break up the swarming fever, in order to secure the strongest colonies. He said he was satisfied long since that a strong colony divided into two moderately so, will not secure half the quantity of

surplus they would if they remained together. Hence the motive to prevent swarming. Up to this time he had operated to make all equally strong. I never saw a lot of 70 hives that were so nearly equal in strength as this one. His weakest were re-inforced by help from the strongest in this way: A comb full of brood near maturity, and sealed up, was taken from the strongest hive, divested of mature bees, and given to a weak one. This brood required no attention from those it was given to further than to be kept warm. It would all mature and hatch out in a few days, and remain where matured, adding greatly to the strength of the stock. Two or three combs, even if taken from different hives, make a weak hive as strong as the best. The hives from which the brood was taken were supplied with clean, empty combs, which were soon filled. The yield of honey up to this time had been only moderate. Hence there was more brood than honey in every comb. He had boxes on every hive; extracting, in which they were just commencing, seemed unnecessary so far. His hives are described in the *American Agriculturist*, June, 1873. Without them, he says, he could not afford to manage bees. On his arrival he commenced operations at once. Took off the roof and top of the hive. Raised the latches of the corners, and took away the four sides, and left the combs and the 24 boxes at the sides and top as yet standing on the bottom board, not disturbing a bee. The boxes could be picked up from any side, and set off with the bees in them, which left the first outside combs and bees on them exposed, but they seemed so demoralized by the sudden exposure to the light, that they showed but little disposition to sting. If any anger was manifested, the smoke was at hand to quiet them. A person stood on each side, unhooked and picked up a comb, and looked it over for the queen, when, if not seen, it was hooked on a bottom board placed at the side, just large enough for six. Another was looked over in the same way, until the queen was found and put in a cage. Two combs were left on the old stand with six empty frames put on with them; the boxes were then put on the same as before, and the hive shut up. The queen was then put in. The combs on the new bottom board had most of the bees shaken from them in front of the old hive, and were then covered with a box just large enough to do it—entrance very small. Enough young bees would remain to nurse and keep warm the immature brood, and it was all that they were expected to do for three or four days. The time taken to do this did not exceed ten minutes. The bees in the old hive would continue to work in the boxes, and put new white comb in the empty frames. At the end of three or four days, the frames with the new combs were to be removed, and the old ones returned to the original hive, after removing all queen cells from them. The new white comb that was built in the empty frames was to be taken out and put in boxes, before any brood had advanced to mar it—it is made faster in the hive than in the boxes. It seems to be pretty well understood that when a surplus box is put on empty, it is longer before the bees even begin to make comb, than it takes to fill the box with honey when they have combs to hold it, ready made and put in. A piece, an inch square, is a great encouragement to begin in the boxes, but a piece of new white comb, the full size of the box, is still greater, because they have nothing to do but fill it, and lengthen the cells a little and seal over. Experience has proved this correct in the past, and more particularly the present season. Secretion of wax has been more tardy this season than usual. And I have no doubt that this artifice to get combs ready made to put in his boxes—instead of having it made there as they want to fill it—will add thousands of pounds of honey to the amount he will get—counting all his stands—I came near putting it 10,000.

It has not been a good season in this section for extraction, it having been so very wet, without a whole week of pleasant weather—several weeks can be counted up to this time, July 1st, without a pleasant day. So little honey was obtained early, that there was plenty of room in the comb for brood. The bees seemed to get plenty of pollen to nourish it with, and nearly every square inch was filled, when a half dozen pounds would exceed the whole amount of the honey in the live—one hive contained even less than a half pound, and yet had commenced to store in the boxes. This state of things being general, led to the prediction that it was going to be a swarming season. I ventured the suggestion. It has been verified. Every fair day through July has sent out swarms. I doubt whether my friend succeeded in breaking up the swarming fever; I have not heard. But this is quite certain, that he succeeded in getting a good supply of pure white comb for his boxes. When a good quantity of empty old comb is on hand, and given to the bees as they begin to accumulate honey, and if extracted thoroughly, it has a tendency to discourage swarming more than anything else that we have discovered. I know a man who had a strong early colony, and did not deprive it of any brood to help weak ones, but added empty combs in between full ones, until they had over thirty, 10x18 inches square. Nearly all were pretty well

filled with brood, and when the flowers began to yield plentifully, there was a force of three or four strong swarms to gather it. Basswood, in connection with clover, yielded at once for a few days. At this time he extracted and weighed what was collected in two days, which amounted to 57¼ pounds. This is the greatest amount I ever knew of. Time was when I thought 3½ lbs. a day was extraordinary. I once weighed some box-hives, when they had to make combs to hold the honey as collected. One hive gathered 12 lbs., another 16 lbs. in a week. The yield of honey probably was as bounteous as it was during the two days mentioned. I mention these things, to show that some of us have learned to obtain more from the same number of bees, in less time than we did only a few years since. What is there to discourage us? If dairymen are to be commended for obtaining more and better cheese from a given number of cows, or the farmer more wheat from the same number of acres, are we not entitled to some credit for the effort to obtain the larger amount and better quality of honey?

It is important that every hive—in most localities—be now thoroughly examined. See if there is a prolific queen and a strong colony for winter, if there is any foul brood, and if the stores are sufficient for winter. If the queen is absent, give them one. If right, and bees are wanting, feed moderately every day steadily during this month. If queen and bees are right, and stores are scarce, from extracting it all out, or other cause, feed a little more, not over two pounds a day. I will say further next month. Syrup made of white sugar, is good for winter stores. The difference in price per pound between honey and sugar is from 5 to 25 cents, and when the price for pounds enough is reckoned, it will pay for some trouble.

Care must be exercised in taking off boxes—which should be done as soon as honey falls—to prevent the honey from being carried out. It is taken from unsealed combs first, and sealed ones next. Bees that are in the boxes, when off, will each take its load, and immediately return for more; if they can have access to the boxes, they will do it at any season when honey is scarce. To get rid of these with little trouble, take an empty barrel—one head out—put in the boxes, so that the bees can creep out, and cover the barrel with thin muslin; they will collect on the under side in the endeavor to escape. Turn it over quickly a few times, they will all leave, and if unable to get to the boxes again, will soon be quiet.

Game Fowls and our Poultry Societies.

It is a noticeable fact that the department of Games in our poultry exhibitions is the great center of attraction. Game fowls command higher prices than any of the old varieties, the eggs sell higher, and they are more extensively advertised in the poultry journals. The secret of this popularity lies mainly in the use to which these birds are put. The game is unquestionably a good bird for eating, but is no better than some of the less quarrelsome varieties. They are prolific, but are surpassed by other varieties. They are quite handsome, but this is not what they are bred for. The only thing in which they excel all other domestic fowls, is their capacity to fight until the last gasp. No doubt, many breed them for their flesh and eggs. They are frequently crossed with other fowls, but their quarrelsome disposition does not make them favorites with the poultry-men who only want flesh and eggs. They are mostly bred for the pit, and there is unquestionably an increasing love of this cruel sport, principally among a certain class in our cities and villages. Cock fights are common, held in some places on the sly, in other places quite openly, and attended by the same rabble that run after prize fights in the ring, and for the same reason. They show courage, and draw blood, and offer opportunities for betting and gambling. Frequently a main is fought, and several cocks are pitted against a similar number upon the other side. It is expected in these contests that all the cocks upon one side will be killed. The worst passions are stirred by these brute contests, and there is the same objection to them that there is to other forms of gambling. The bull fights of Spain are no more bloody and cruel. They tend to harden

the sensibilities, and so corrupt the morals. All the associations are low and degrading. There may be laws against these contests in some of the States, but they are seldom enforced, and do not remedy the evil. Our poultry societies have some responsibility in fostering the breeding of these birds. As a matter of fact, we think most of them would be found obnoxious to the charge of discriminating in their favor, instead of encouraging the more useful and ornamental varieties. In looking over the special premiums of the fifth exhibition of the Connecticut Poultry Society, where we should hardly look for such discrimination, we find the highest premium in the list, valued at \$50, offered for the best collection of game fowls. With the single exception of the Asiatic fowls, the largest amount of premiums is offered for games. The premiums for turkeys, the most valuable of all our domestic birds, amount to \$34. For geese, \$8. For Hamburgs, \$28. For the games, \$225. Now, if the object of these societies is the promotion of the common weal, the highest premiums should be offered for the birds that are most useful, or for those that promise to be such. The managers should so arrange the list of premiums, as to draw out the birds that will be most profitable upon the farm, and in the poultry yard. No special inducements are needed for the breeding of game fowls. That business would take care of itself, if the premiums were altogether diverted to the more useful classes.

Canning Tomatoes, Fruits, etc.

A number of inquiries have reached us in regard to the canning business, especially with reference to tomatoes. One who has a few acres of tomatoes that promise a heavy crop, naturally wishes to make the most of them, and he thinks that his crop would be more profitable if he could can it, than if it were sold at the ordinary prices, and he writes to us to tell him how to do it. Persons who make these inquiries have but little idea of the extent of the canning business, or they would see the impracticability of carrying it on upon a small scale. In the large establishments, such is the division of labor and the employment of machinery, that the products are turned out at an exceedingly low rate. Three pound cans of tomatoes, are sold by dealers in New York at a handsome profit, at \$2.25 a dozen. There is no establishment, so far as we are aware, that puts up tomatoes exclusively, the operations include peaches and other fruits, and in Maryland, where are the largest factories, the working season is made continuous, by putting up oysters for the inland markets. We visited one of these large establishments in the peach season, and found over 100 women, black and white, engaged in peeling and cutting up peaches; all the cans used were made by machinery on the place, and the establishment was a small village in itself. We mention these matters, to show what one who undertakes the business in a small way has to compete with, and how difficult it will be for one, single-handed, to undertake a business that can only be profitably carried on upon a large scale, with every facility for rapid work. In the canning factory referred to, the peaches were peeled on the upper floor, and thrown into hoppers which extended to tables on the lower floor, the cans were filled by placing them under the lower end of the hoppers, and pressing the fruit in with the fingers.

The cans were then passed to another table, where syrup—about one pound of sugar to the gallon of water—was filled in, time being allowed for all the air between the peaches to escape. The cans then passed to hands who washed away whatever syrup was spilled upon them, and then they went to the tin-men; these put on the small circular cover, soldering it very rapidly; each cover had a small hole pricked in the center, to allow the escape of air, and after the soldering was complete, this hole was closed by a drop of solder. The soldered cans were then placed in an iron grating, and lowered into a tank of water which could be heated by steam. As the temperature of the water increased any imperfect cans could be discovered and taken out. The water was then raised to boiling, and the cans cooked half an hour, more or less, according to the size and the kind of the peaches. The cans were then placed in a store room, which had the capacity of a million, and was already well filled. The labels are not put upon the cans until they are ready to be packed in boxes. The factory was not running upon tomatoes at the time of our visit, and to answer inquiries as to canning these, we give an extract from the Oneida Circular. The canned goods put up by the Oneida community have an excellent reputation, and this is due to the great care with which their processes are conducted. We do not know what is the custom with the Oneida Community, but others engaged in the business, early in the season make contracts with farmers for their whole crop, early and late, at a given price, and they also make their contracts with dealers to take their product, long before a single can is put up.

The method of preserving tomatoes is simple. They are first slightly scalded, sufficiently to peel nicely, and when peeled, are thrown into pans in order to let some of the watery part drain off. They are then packed into 2½ pound cans, leaving just room enough for a large spoonful of syrup. This syrup is made by dissolving 2½ pounds of salt, and the same amount of sugar, in one gallon of water. The cans are then sealed and placed on sheet-iron pans, holding thirty-five cans each, and lowered into a vat containing boiling water of sufficient depth to cover them. If a can is not tight, it may be readily discovered by the air which will escape through the hole, causing bubbles to rise to the surface of the water. The leaky can should be immediately taken out and the hole stopped. All kinds of vegetables and fruits put up in cans, should be first tested in this way before they are bathed. When a vat full of tomatoes has thus been tested and prepared, the pans are lowered into the vat, one top of the other, and the steam let on, allowing the tomatoes to boil thirty minutes. In case cans larger in diameter are used, longer cooking will be necessary. When the tomatoes are done, the pans and their contents are hoisted out, and the cans, after they have cooled a little, are vented by opening the prick-hole in the cap with the soldering iron, allowing the steam to escape, and then immediately closing the aperture. When the cans have cooled, if all right, the heads will snap in by a slight pressure, showing that there is a good vacuum.

Ogden Farm Papers.—No. 55.

I have several letters from parties interested in the record of pedigrees in the Herd Register of the American Jersey Cattle Club, of which I am Secretary. One asks: "Is it really a fact that the fee for registration has been increased to \$5? In talking of the matter, I have heard expression given to intentions, by breeders in this section, that if carried out, will not tend to

increase the number of herd registered animals. Who are eligible, and what are the requirements for admission to the club?—I should like your opinion as to whether it is advisable to breed from a Jersey with a pink skin. I have known several animals exhibiting this peculiarity, that made yellow butter, and have also seen cows with a yellow hide, whose product of butter was very light colored. I can account for these facts only by the following supposition. Every animal has the power of secreting a given amount of the yellow coloring matter. An equal development in one may be sufficient to furnish an abundant supply for both skin and mammary glands; in another the production in its escape from the body, may be excreted almost wholly by the skin, or, on the other hand, be secreted in connection with the milk. Now, is this theory correct, or are the animals that I have noticed exceptions to the law, that the color of the skin is an index of the color of the butter?"

As many are interested in the question of registration, I think it may be worth while to say, that it was proposed at the last meeting, and approved by the club at large, to raise the charge for animals not belonging to members of the club to \$5 each, the reasons for the change being that the club has done much to extend a knowledge of the value of Jersey cattle, and to secure a reliable record of pedigrees for the benefit of all who are interested in the breed, and that its present plans contemplate the expenditure of considerable sums in ways which will benefit equally those who are, and those who are not, members. The members have contributed, by their initiation fees, to the fund for the accomplishment of these objects, and it was considered only just that those who have taken no part in the movement should be asked to contribute in the way of increased registration fees.

The club is not a money making institution, and whatever income it may receive will be expended for public benefit. At the same time it has not yet been decided that the fee shall be increased, and it remains at present at the old amount—\$2. The membership of the club is open to all who, after being recommended by a member as a "careful and reliable breeder," shall not be voted down when their names are submitted for election. Since the organization of the club there have been, I think, but two instances of rejection, and both of these were for sufficient cause.

The question of the formation of the yellow pigment of the Channel Islands cow, is understood only in a very empirical way, and, as far as I know, it is impossible to answer the question propounded. I know no reason for refuting the theory advanced by my correspondent, neither do I think that his position, in the present state of our knowledge, can be scientifically substantiated. I have known very good cows with pink hides to produce quite yellow butter. I have also known those with a much more yellow hide, who gave butter of a lighter shade, but I believe that I never knew one, the yellow secretion of whose *ears* was not a pretty fair index to the color of the butter. In Guernseys especially, where the butter is often yellower than in Jerseys, it is by no means unusual to see pink-skinned cows, but the yellow ear is almost universal.

Mr. Mackie, to whose excellent herd I have previously alluded, wrote me in June: "I have tested my 3-year old heifer Mulberry 2nd.

In 7 days on grass alone she made 13 lbs. 4 oz. of butter, in the last half of the week making fully 2 lbs. per day." This has occasionally been exceeded, but it is not often equaled, and the statement is the more valuable from the entirely reliable source from which it emanates.

I have received the following from Mr. J. M. Codman, Brookline, Mass., who has made an importation of Guernsey cattle, having been induced to do so by the deep color of the Guernsey butter, exhibited at the Channel Islands Agricultural Fair in Jersey a few years ago. He says: "I must differ with you in your theory that Guernseys are more apt to take on flesh while milking. I do not see that it is more characteristic of this breed than of Jerseys, individuals do, and do not. I think it possible that, for ability and service for dairy farmers, the Guernseys would be more desirable; in regard to color of butter, I think your position about coloring is not quite tenable. Artificial color is virtually a deception—you do not know what you buy. Why should a yellow skin be a 'point' of such value in judging cattle? Why color at all, unless to imitate something worth imitating, to make butter sell? If you say with me that 'there is no question as to the superiority of color with the Guernseys,' and if you state in the *Agriculturist* that if 'you would go in for butter alone, you would have a herd of selected Guernseys'? How do you reconcile the two statements, without implying that the Guernseys have other points of superiority besides color of product? Then as to the main question, which breed will get the most butter from a given amount of food: A large Guernsey would naturally eat more than a small Jersey, but I think it would be accounted for in the pail. I have not many data for submission, or comparative tests, but will give you two that I have, to compare with others that you may have, and as an addition to your statistics, from which to draw a sound opinion.

"'Sapphire,' Guernsey cow, calved first calf Oct. 15th, 1872. Jan. 13th, 1872—11 quarts milk made 2 quarts cream— $1\frac{1}{2}$ lbs. butter. $6\frac{2}{7}$ quarts milk to 1 lb. butter.

"Jan. 9th, 1872—mixed milk of 4 Guernseys at different distances from calving time—13 quarts milk made 3 quarts cream— $2\frac{1}{2}$ lbs. butter— $5\frac{3}{4}$ quarts milk to 1 lb. butter."

I am glad of the opportunity to publish this or anything else I may learn in favor of the Guernseys, and I am quite ready to concede all that their admirers seem to claim, save that I do not believe them as a race to be materially more productive than Jerseys, nor is the deeper color of their butter of special importance, for Jersey butter is quite yellow enough. No farmer, who has a taste for fine stock, would, I think, put the larger size and deeper coloring of the Guernseys into the scale against the more stylish, thoroughbred, and attractive look of the Jerseys. If two animals are of equal practical excellence, personal beauty will always bear the palm: and this alone I believe to be the secret of the greater popularity of the Jersey breed. After a pretty thorough investigation of the whole subject here and on the Islands, I believe that the evidence of practical productiveness and value is about equally balanced between the two races.

W. C. Blackfan, of Penn., finds fault with my recommendation for making hay, as given in the July number of this series. He says: "I do not object to starting the mower, as he

says, at 5 o'clock, but prefer running it after the dew is off, for this reason: the dew will dry off the grass better standing than cut, and cutting without the dew it will not lay so compact, therefore it will dry faster. My plan is, to start the mower in the morning, and if a good day, the hay will be ready to start the rake by one o'clock, hauling by two. And this I would state constitutes agricultural economy."—If grass is to be left as it falls from the machine, until the rake is started, of course the dew should be off before it is cut, but my plan contemplated the constant active use of the tedding machine, from the time the mower stops, say at 8 o'clock in the morning, until the grass is ready for raking. Probably the radical difference between Mr. Blackfan and myself is, that I propose to cut grass when very young and tender, "just in blossom," while he leaves it to stand until so ripe that its needs but little further drying. I still think that practical "agricultural economy" will be much better advanced by the pursuit of my system, especially when we consider the greater nutritive value of early cut hay.

The deep can system is slowly making its way throughout the country. I have a letter from a correspondent in Southwestern Virginia, who says: "From reading your papers, I was induced to try the deep can system at my butter factory, and I am so well pleased with the result, that I write to thank you for giving the public such information. Up to this time I have used common tin cans; will you please give me the name of a house in New York, where I can get the kind that you use?" (Iron-clad Can Co., N. Y.)

Last April I received from a correspondent in Iowa, a marvellous statement about the production of a young Jersey cow, which was to calve in about six weeks, but was still giving from 3 to 4 quarts a day, and showing over 40 per cent. of cream. I requested him to write again after she had had her next calf. He now writes, July 28th: "My heifer did not come in until a month later than I supposed she would, some three weeks ago. For the last three weeks I have kept account of her milk. She is running in pasture, wild marsh grass, about a mile from my house. I take her there mornings, and bring her home nights. There is some irregularity about it, which I suppose accounts for the fact that her yield is not regular. I feed her well at home, night and morning. During the last week she has not given less than 17 quarts a day, and has given $19\frac{1}{2}$ quarts, probably 18 quarts on the average. I think this is a large amount for a three year-old heifer, especially when she is not on extra pasture, and a long drive at that. As to quality I have made but one test, having been away most of the time. That was about five days ago. The milk showed 23 per cent. of cream. We have made some butter, but not in a way to give accurate figures. My wife says it takes 8 quarts to make a pound of butter. How is this as a showing for a three year-old Jersey, taking quality, quantity, and circumstances into consideration?"—I give this statement partly because it is a remarkable one, and comes from one whom I believe to be entirely reliable; partly however as an answer to a suggestion which has been made frequently, that a record of the production of a dairy cow should be taken as a test at exhibitions, rather than the pedigree and general character of the animal. If we make production the test, we

are bound to accept every apparently authentic statement that is received. And especially in a country like ours, it would be impossible to investigate the reliability of those making the reports, and the accuracy of the methods which had been adopted. The statement made above is not an improbable one. There is no question that the writer fully believes it to be true. At the same time, I should hesitate to award a premium on such a statement, without knowing absolutely that there had been no possibility of error, that the quarts had been measured by the same careful person, that they had been regularly recorded, that the week's product of milk had been carefully set and skimmed by itself, and that the product showed an average of one pound of butter for each 8 quarts of milk. While it would be practicable to secure evidence to this effect in a few individual cases, no such test can be established without the danger of excluding equally meritorious animals, simply because of the lack of authenticity concerning the evidence. The owner of this heifer is certainly to be congratulated upon the great prize he has drawn, and congratulations are equally due to the agricultural neighborhood in which he lives, that they have the opportunity of securing bulls from such an animal.

The Mount Fordham Herd.

The Mount Fordham herd of Shorthorns consists of between 30 and 40 head of choice animals of the most popular strains. They are the property of Col. L. G. Morris, of Fordham, N. Y., and have been selected and imported by himself in 1872, or purchased at the New York Mills sale in 1873. The bull "Beau of Oxford," which leads the herd, was purchased of Hon. E. Cornell. It is doubtful if there is another herd in America that represents more fully the best strains of what is known as the Bates blood. On a recent visit to Mount Fordham we were favored with an opportunity of procuring portraits from life of three animals of this herd, which are presented upon the first page of our present number. These fine specimens of this breed of cattle very fairly represent the herd, which is remarkably even in character and excellence. The bull "Earl of Clarence" is roan in color, was calved September 12th, 1871, and is now about three years old. He was bred by the Earl of Cawdor, his sire was "3d Duke of Clarence," and his dam "Henrietta the 9th," which was by "Duke of Wharfedale," out of "Henricetta." He is a fine young bull. The foremost cow is "Tacita 3d," a light roan, five years old, of the White Rose family, and counts in her pedigree the bulls "Duke of Claro," "May Duke," "Duke of Gloster," "Earl of Derby," which was bred by Mr. Bates, and also two other Bates' bulls. This is a very smooth cow, with a fine coat, and is a good milker. The cow in the rear of "Tacita 3d" is "Lady Worcester 8th," a red roan, 4 years old, of the Wild Eyes family, and very finely bred. Her pedigree includes "Mar-ton Duke," "Red Duke 3d," "Duke of York," "2d Cleveland Lad," and the "Duke of Northumberland," the last three all bred by Mr. Bates. Col. Morris is a breeder of long experience, he having been engaged in enriching the Shorthorn stock of America since 1850. The catalogue of his herd recently issued contains the pedigrees of all the animals except the present year's calves. None of the herd are for sale, but bull calves and yearling bulls

The Grayling.

The fish culturists have during the present season been much excited over the Grayling and its artificial propagation. That most excellent authority upon all that relates to hunting and fishing, *Forest and Stream*, has devoted much space to making this fish known to anglers and fish culturists. The fish is quite abundant in some of the Western waters, and there is probably more than one species. The one especially talked about is called the Michigan Grayling, *Thymallus tricolor*, but an English correspondent of the paper just alluded to, declares from the engraving that the fish is the same as the species found in European waters,

Salmo Thymallus, or, as called by other authorities, *Thymallus vulgaris*. At all events, whether ours be the same or not, there is a strong probability that a valuable fish will soon be introduced into our Eastern streams, and thus not only add to our food supplies, but furnish another important fish to our anglers, for it is emphatically a game fish, taking the fly readily. The credit of first bringing the grayling into domestication, is due to Mr. Fred. Mather, of Honeye Falls, N. Y., a gentleman who has heretofore given us interesting notes on fish culture. Upon his arrival home in April, after his expedition to Michigan, (of which an interesting account was given in *Forest and Stream*),

he sent us word of his success; he started from Crawford, Mich., with 180 fish, and reached home with the loss of only 12. Mr. Mather sent one of his fish to *Forest and Stream*, from which Mr. Forbes made a drawing, which appeared in that journal, and also the one which is here presented. It will be seen that it is longer in proportion to its thickness, than the trout, and is thought by many to be equally beautiful. Mr. Mather is very enthusiastic over this matter, and we can

not do better than give the description he gave in the above named journal, where he says, April 23: "The grayling has all the fins of a trout; his pectorals are olive brown, with a bluish cast at the end (I am describing him in the water as

I saw him in the ponds an hour ago), the ventrals are large and beautifully striped with alternate streaks of brown and pink, the anal is plain brown, the caudal is very forked and plain, while the crowning glory is its immense dorsal;

relationships we should expect to find the Grayling excellent upon the table. It is held in high esteem in Europe, and we have heard Europeans regret its absence in this country. It is very local in its habits in England, but

that peculiarity may be overcome by artificial propagation. We look forward to the time, and that not a far distant one, when every farmer who has a permanent stream or pond upon his place, can be able to go to it with as much certainty of obtaining the desired quantity of fish, as he can now go to his barn-yard for poultry, and we regard every improvement in fish culture as of importance. Especially then is the introduction of a hitherto almost unknown fish, a matter of general interest, and

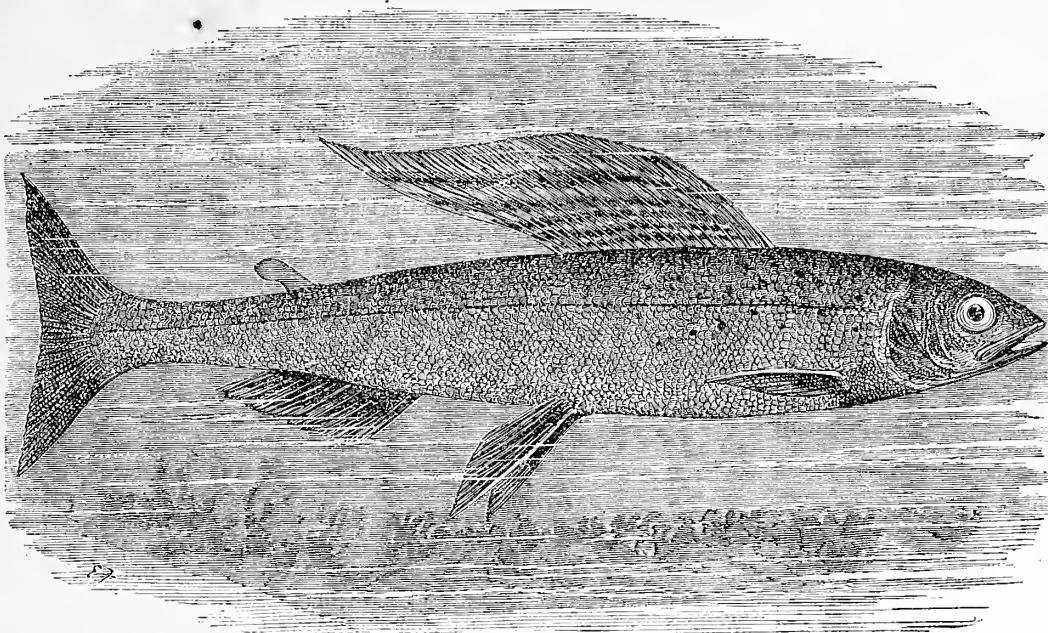

THE GRAYLING.

this fin rises forward of the middle of its back, and in a fish a foot long, it will be nearly three inches in length by two high, having a graceful curved outline, and from 18 to 20 rays dotted with large red or bluish purple spots, which in life are brilliant, and are surrounded with an emerald green, which fades after death; it does not seem as if this green could be represented by the painter's art; it is the changeable shade seen in the tail of the peacock."

The grayling spawns in the spring, and Mr. Mather writes us, that he thinks that it will probably replace the trout, in streams where there are numerous enemies that devour the

we desire to give full credit to Mr. Mather for his active agency, and to our cotemporary for the enterprise it has manifested in the matter.

Imperial Pekin Ducks.

BY GEO. P. ANTHONY, WESTERLY, R. I.

[In February last we gave the first account, (so far as we are aware), of these new ducks. Recently Mr. George P. Anthony, of Westerly, R. I., who has been successful in raising them, sent us a photograph of a pair of his birds, from which the engraving is made; with the accompanying notes. Ed.]

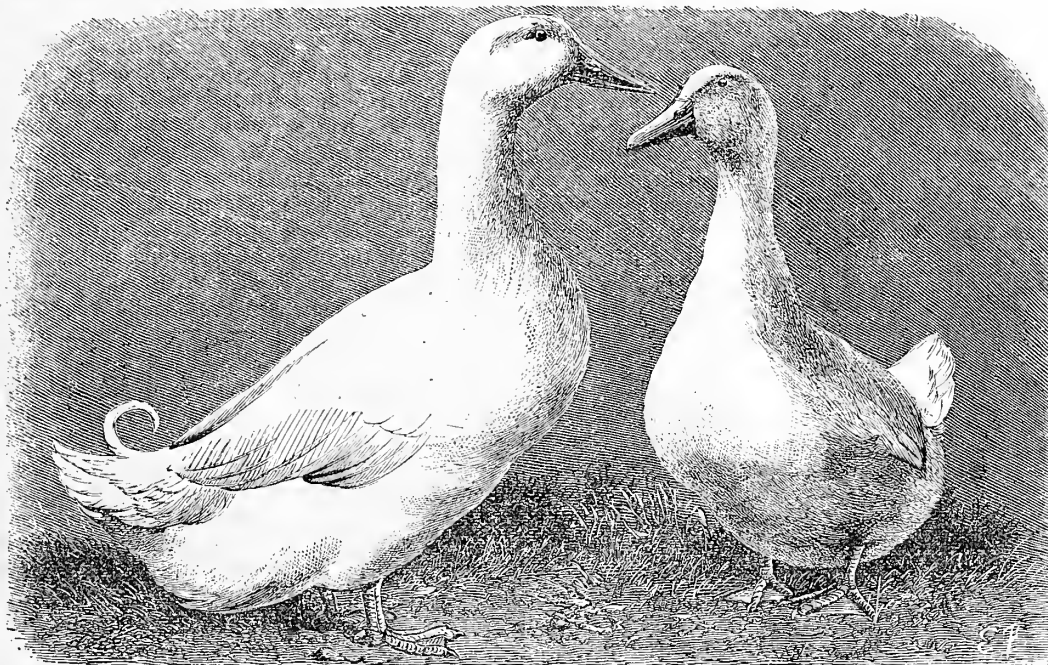

IMPERIAL PEKIN DUCKS.

The Imperial Pekin Duck was unknown in this country or Europe, previous to the spring of 1873; the following is a brief account of their importation. Mr. McGrath, of the firm of Fogg & Co., engaged in the Japan and China trade, in one of his excursions in China, first saw these ducks at the city of Pekin, and from their large size, thought them a small breed of geese. He succeeded in purchasing a number of eggs, and carried them to Shanghai, where, placing them under hens, he in due time

obtained fifteen ducklings sufficiently mature to ship in charge of Mr. James E. Palmer, who was about returning to America. He offered Mr. P. one-half the birds that he should bring to port alive, and the latter, accepting the offer, took

trout spawn in the long period required to hatch it. The Grayling belongs to the *Salmonidae*, or Salmon Family, of which the Salmon is the type, and our lake and brook trout still more familiar representatives, and from its

charge of them. Six ducks and three drakes survived the voyage of 124 days, and were landed in New-York on the 13th of March, 1873. Leaving three ducks and two drakes, consigned to parties in New-York, to be sent to Mr. McGrath's family, (who never received them, as they were killed and eaten in the city). Mr. P. took the three remaining ducks and drake to his home at Wequetequoc, in Stonington, Conn. They soon recovered from the effects of their long voyage, and commenced laying the latter part of March, and continued to lay until the last of July. They are very prolific, the three ducks laying about 325 eggs.

The ducks are white, with a yellowish tinge to the under part of the feathers; their wings are a little less than medium length, as compared with other varieties; they make as little effort to fly as the large Asiatic fowls, and they can be as easily kept in enclosures. Their beaks are yellow; necks long; legs short and red. When the eggs are hatched under hens, the ducklings come out of the shell much stronger, if the eggs are dampened every day, (after the first 15 days), in water a little above blood heat, and replaced under the hen.

The ducks are very large, and uniform in size, weighing at four months old about twelve pounds to the pair. They appear to be very hardy, not minding severe weather. Water to drink seems to be all they require to bring them to perfect development.

I was more successful in rearing them with only a dish filled to the depth of one inch with water, than were those who had the advantages of a pond and running stream.

Walks and Talks on the Farm.—No. 129.

Newton Reed writes: "In preparing my ground for wheat, I haul the manure in June on to the corn stubble, and plow it immediately under; and the land is plowed again two or three times, before sowing the wheat. I have practiced this method several years, with good satisfaction, except a slight suspicion, that there may be some loss to the manure."

I should have no fear on that score. I do not think there is likely to be any loss of manure from evaporation, and I do not see that there is much danger of the manure leaching out of the soil during the summer months. I do not recollect an instance on my farm of our ever having rain enough during the summer to start an underdrain, after it had once stopped. In the spring, and perhaps late in the fall, a small portion of the manure may leach out of the soil, but I think not in the summer, even if the land is in bare fallow. I think Mr. Reed's plan a very good one. "My object," he says, "is to clean the land of weeds, thistles, and quack-grass. The oat crop, which used to come in between corn and wheat, has become here so poor, and allows such a growth of weeds, that I am willing to omit it, and cultivate the land as a fallow. We expect enough better crop of wheat and grass, to pay for loss of the oats."

Mr. R. adds: "I sell milk to Borden's Condensing Milk Factory, and keep as many cows as my grass will feed, and besides I feed all my corn, and as much bran purchased for the purpose."

Mr. R. says that bran makes rich manure. There is no doubt on this point. I think if I was a dairy farmer, and could dispose of the milk at a paying price, I should aim to feed at

least a ton of bran a year to each cow, and half a ton of corn meal. I am not sure that it would pay for the first year or two, but it would be profitable in the end, provided the manure was carefully saved and applied. The great objection to such a system is the fluctuations in the price of bran. Sometimes we can buy it here for \$15 per ton, and sometimes we must pay \$35 per ton.

"Yes," said the Deacon, "I take it the dairy farmers understand their own business. They will adopt the system which long experience has taught them is the best and safest."

That is all true, and I would be the last man to assume that I understand how to manage a dairy farm as well as a dairy farmer. I was only saying that it seemed to me, that a farmer, who had a ready market for all the milk he could produce, at a fair price, could easily manage to enrich his land. With us here in the wheat-growing section, the great trouble is to make a profit on our live stock. If we could do this, it would be an easy matter to make our farms rich.

Last year I manured the east side of my wheat field. The manure was rich and well rotted. We put on only a slight dressing, but the effect was very decided. When we were cutting the wheat, one of the men who were binding after the machine, and who did not know that only a part of the field was manured, remarked, "if it was all as heavy, as it is on the east-side, we should have something to do. The straw is perhaps no longer, but the heads are larger, and every one of them is full of grain." I think the thrashing machine will show this to be true. I have frequently heard farmers say, when discussing the question as to why we can not raise as good wheat now as formerly, "it is not because our land is poor. We can grow straw enough, but the grain is not there." So far as my observation goes, we seldom get too much straw. But whether this is true or not, I feel sure that a little rich manure is precisely what many of our wheat fields need, to enable them to yield a good crop of grain.

Last year my wheat was seriously injured by the Hessian fly. This year the crop is almost entirely free from it. I have been thinking whether the harrowing, which I gave the wheat last fall, has any connection with this fact. As I understand the matter, the Hessian fly lays its eggs on the leaves of the young wheat plant early in the fall, and it is just possible that the repeated harrowings interfered in some way with the process of hatching. I do not know that there is anything in this idea.

We have had a grand crop of hay this year, and it is of excellent quality. Hay and straw will be cheap with us the coming winter, and store cattle and sheep are consequently likely to be wanted at better prices. An old farmer of my acquaintance who lives near the city, has a big barn, and he says he has found from experience, that if he puts hay into the barn, and lets it stay there until he can get \$20 per ton for it, he has never had to keep it over three years. It is seldom that he has to keep it two years. It is with hay as with wool, wheat, corn, and barley; when the price is low everybody seems willing to sell, but when prices are high, everybody is desirous of holding.

"Old corn is scarce," writes a farmer in Missouri, "and is worth 75c. to 80c. per bushel."

I do not know the fact, but I presume a year or eighteen month's ago, farmers were selling their corn there for 25 cents, or using it for fuel. "Well," replied the Deacon, "what are you going to do about it?" Nothing. It has always been so, and what has been, will be. What we want is more faith. We should not go with the stream. You, Deacon, and many others, thought the bottom had fallen out of farming. You thought we should never see good prices, good crops, and good times anymore. "I don't see them yet," replied the Deacon. They are coming, nevertheless. Stick to the farm; farm well, and your chances of success are certainly as good as in any other business. "The railroads are ruining us," said the Squire, "they have just advanced their rates on cattle." I am not going to defend the railroads. But this advance in rates will not hurt the good farmer as much as the farmer who keeps nothing but inferior stock, and half starves it. A choice well-bred and well fed steer, weighing 1500 lbs., is worth \$100 in Chicago. The freight on him to New York is \$8.25. A common, inferior steer, weighing 750 lbs., is worth in Chicago \$20, and the freight on him to New York, is \$4.12. The freight on two thousand dollars worth of the good steers is \$175; and on two thousand dollars worth of the inferior animals \$412.50. Let us make the railroads do the fair thing, if we can, but in the meantime, let us not neglect to improve our herds of cattle, sheep, and hogs.

I have always said that winter wheat was our best crop to seed down with. This I believe is also the general opinion of our farmers. But this year I have wheat on one half of a field, and barley on the other half. I seeded the whole field this spring with clover, sowing a peck per acre. The young clover on the wheat is only fair, while on the barley it is superb! "Yes," said the Deacon, "I never saw a handsomer field of barley, or a handsomer patch of clover." It is worth something to get such a confession from the Deacon. I have not thrashed yet, but I expect 45 or 50 bushels of barley per acre.

Geo. M. Lyons, of Titusville, Pa., writes me that he shall be glad to furnish crude petroleum by the barrel, to any readers of the *American Agriculturist*. Where petroleum can be obtained at a cheap rate, I have no hesitation in recommending its frequent use for preserving wood. The longer I use it the better I like it. I have an old Walter A. Wood's Reaper that I have used and abused for ten years, and the platform and other wood work of the machine is as sound and good as when it was new. Every year I wash it over with petroleum, wood work, iron, and all. Fork, hoe and rake handles are greatly benefited by a washing of petroleum every few months. It makes them hard and smooth. We had occasion a few days since to bore a hole in an old cultivator that has had frequent applications of petroleum, and we found it no easy matter to get the auger into it. It was almost as hard as iron. But there is one thing about petroleum that ought to be understood. A slight dressing seems to do very little good. You must get rid of the idea that you are painting. You want to get the petroleum into the wood. The drier the wood, and the hotter the weather, the better. The end of a board, or of a stick of timber, will absorb far more petroleum than the sides. The pores will absorb the oil, and as fast as it is taken in, put on more. To a

careful farmer, who houses his implements and machines, petroleum is not necessary. He would be likely to think it a nuisance, as the implements will for some time afterwards soil his hands and his clothes. But to a careless farmer, like myself, who leaves his implements and machines more or less exposed to the weather, petroleum will be of great benefit.

"Better learn to put things up," says the Deacon. I admit that. But even the Deacon sometimes leaves a wagon cracking in the sun, or a hay-rack rotting in the rain, and his stone-boat is not always turned up on its side.

We are now, (July 23,) thrashing our wheat—drawing it in from the field as we thrash. I am the only man in this neighborhood who adopts this practice. Come and see how it works. After the wheat is cut, and the sheaves put into stooks, we rake the ground carefully between the rows of stooks, going over the ground twice in opposite directions. Before commencing to thrash, we load up all the rakings. When these are thrashed, all is plain sailing. We have three wagons and two teams; as soon as a wagon is unloaded, it is pushed out of the way by hand, and the next load is driven up. The man who has just unloaded the previous wagon, takes off the team and puts it on to the empty wagon, and goes to the field for another load. He reaches the pitcher just as he has finished the third load, and the work is fairly commenced. There is one wagon at the machine, another going back or forth, and another being loaded in the field. Where this kind of work is new to the men, it will be likely to dissipate some of their old traditions. They will find that a machine does not thrash as fast as they have hitherto supposed. Two of my best men jumped on to the wagon to throw the sheaves to the machine. I had a man to spare for half an hour, so I said nothing. It is one of the old notions that it takes two, three, or four men to "get the grain to the machine" from the stack or bay. "One man can't give it us as fast as we want it," said the thrashers. "Perhaps not," I replied, "but at any rate one man can throw the sheaves off the wagon, as fast as the man in the field can pitch them on to the wagon."—"We want three good men on the straw stack."—This is another traditional notion. "One man is pitching on to a wagon all the grain and straw that is going through that machine."

"But wait. They have just finished a load, and the thrashers see we are talking about them, and are doing their best. Let us see how long it takes to thrash the next load.—How long? Fourteen minutes, and there was 15 bushels in the load. That will do. Now then, about stacking the straw. With a fair crop of wheat like this, that will go say 30 bushels per acre, there is about 100 lbs. of straw to each bushel of grain. That load we have just thrashed, therefore, weighed 2,400 lbs. The machine takes out 900 lbs. of grain, and 1,500 lbs. of straw is elevated by the straw-carrier on to the stack. Now, if one man can pitch 2,400 lbs. on to a wagon, at an average height of 9 feet, why are three stout men required, to handle 1,500 lbs. in the same time on the level?" "You get on to the stack and try it," says the Deacon, "and you will find out."—I have been there a great many times. The labor consists, not in moving the straw, but in moving yourself about the stack. And the way to lessen the labor is to make large forkfuls. An aver-

age forkful of straw, say as large as a two-bushel basket, does not weigh more than 8 lbs. As men usually build a stack, they walk around the outside more than in the center, while the center ought to be kept full and trodden solid, so that, as the stack settles, the inside or roof shall not settle as much as the outside. To do this, as well as to lessen the labor, you should, in building the outside layers of the stack, take pains to get the largest forkfuls of straw, and not waste your strength in placing a thin layer of straw around the outside of the stack. It is like carrying water in a two-quart pail. You move 150 lbs. of your own weight to move 4 lbs. of water.

Every year before commencing to thrash, the question arises "how long and how wide shall we make the stack bottom?"—This year we made it 36 feet long, and 20 feet wide. The machine stands about 3 feet higher than the bottom of the stack. After we had thrashed 402 bushels of wheat, the stack was 24 feet high, with an average width of 25 feet, and an average length of 38 feet. The stack therefore contains 22,800 cubic feet. And if we calculate that each bushel of wheat gives us 100 lbs. of straw, there is 20 tons of straw in the stack. This is not far from my old rule of calculating, that each ton of straw requires about 1,000 cubic feet of space. "But you won't leave your stack without topping it off," remarks the Deacon. No, I have got about 8 tons more straw to put on top. And it has got to go up there whether it will or not. By Monday morning the stack will have settled at least four feet, and I propose to carry the walls up four feet higher than they are now. Then by making a good steep roof, it will hold it all, and we shall have 28 tons of straw in a stack, the bottom of which is 36 feet long, and 20 feet wide. It is of course more labor to top off a high stack, but there is a great advantage in getting as much straw as possible under one roof.

Thick and Thin Seeding.

The fact that plants yield more largely when they are furnished with abundant room, and that the thin seeding of a crop, up to certain limits, yields a better harvest than any thicker seeding, is no new thing. We read of it in the works of the most ancient writers upon agriculture, and early historians record facts illustrative of the advantages of sowing thinly, and of the extraordinary yields of grain from single seeds. Nevertheless the subject is as fresh as ever, and we see every year good farmers wasting large amounts of seed, and sacrificing large portions of their crops. We have recently seen a piece of oats sown with one bushel per acre, which yielded a better crop than a neighboring field sown with four bushels per acre. A few years ago we divided a ten-acre field into five portions, and sowed them with wheat at the rate of one bushel, five pecks, six pecks, seven pecks, and two bushels of seed per acre. There was no perceptible difference in the soil of the field, nor any in the manuring, preparation, or sowing. At harvest time there was a very perceptible difference in the yield, the thinnest sowed portion being by far the best of the field, and the thickest portion the worst. Near the edge of the field, upon the thinnest sown part, where the seed had been thinned out by some pigeons, there were some stools of wheat with 30 stalks, each

bearing an ear; and in this part of the field the difference was mostly shown in this way, and in the length of the ears. The other side of the field, where two bushels had been sown, produced much shorter ears than this portion.

At a meeting of the Midland Farmer's Club, held at Birmingham, England, in June last, Major Hallet read a paper upon thin sowing and selection of seeds. It was illustrative of his experiments in raising what he calls "pedigree wheat." He exhibited a single plant of wheat from a single seed planted alone, which bore 94 stems, one of barley of the same character bearing 110 stems, and one of oats with 87 stems. He stated that a crop of wheat he had sown with single seed 9 inches apart each way produced 108 bushels per acre. He suggested the experiment be tried of drilling 8 quarts of wheat per acre early in September, and one quart additional for each week to the end of the month. Also that seed be selected from the produce of these plots for future sowing, with reference to its hardiness, its trueness to type, its quality of the grain, its productiveness, its power of tillering or casting up numerous stems, its stiffness of straw, and its earliness of ripening. His plan of selecting seed was to take the most perfect grains from the largest ear of the plant with most stalks, and plant them so that the grain from each ear occupied a row by itself, each grain occupied a hole in the row, and the holes 12 inches apart. This plan was repeated yearly, taking each year the best grain produced. By this course in several years he had succeeded in doubling the length of the ears, in trebling their contents, and in increasing the tillering power five-fold. Five pints of wheat planted 12 inches apart each way, upon an acre of ground in September, gave 1,001,880 ears, or 67,760 ears in excess of the crop from 6 pecks per acre sown upon the adjoining field. Later plantings reduced the crop somewhat. Two plants with 24 ears each gave 1,911 and 1,878 grains. 20 ears per foot, with 48 grains to an ear, will produce 88 bushels per acre. A bushel of wheat produced by this thin sowing contained 460,000 grains, while a bushel of ordinary wheat contains 700,000 grains. Here is interesting matter for consideration, and if, as seems scarcely to be doubted, thin seeding is more productive than thick, it might be very profitable to experiment in this direction. It is necessary to remember that for such seeding, to be successful, the soil must be rich and free from weeds, and that the crop also must be kept free from weeds by thorough cultivation. Although with better farming than we now have we can raise large crops, yet it is certain that the possibilities of better farming are not nearly realized as yet.

ROAD-DUST.—Road-dust should be gathered before the season closes. This is often the most convenient absorbent the farmer can command, and a few barrels of it will save a large amount of ammonia in the hennery, the privy, and the stable. Hens should have a large open box full of it under cover, where they may dust themselves at their pleasure. It is an excellent thing to have in the stable, and when saturated with urine makes a valuable fertilizer. The fineness of the dust, continually ground by the iron tires and horse-shoes, is one cause of its favorable action upon crops. That gathered from a clay soil is best—indeed sand, whether from the road or elsewhere, is of but little use as a deodorizer or absorbent.

A Simple Clod Crusher.

A very cheap and effectual clod crusher can be made by connecting a number of round poles together, as shown in the accompanying illustration. Staples are driven into the ends of each pole, by which the pole is fastened to the links of a chain which connect them all to-

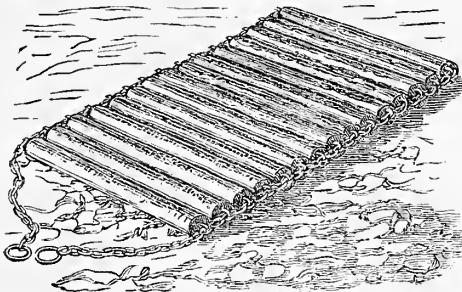

A CLOD CRUSHER OF POLES.

gether. The ends of the chain are furnished with rings, to which the clevis of the double-tree is attached. Being flexible, the drag conforms itself to uneven surfaces. We have found such an implement useful for leveling corn stubble, and smoothing potato ground previous to plowing, also for spreading manure evenly, or for breaking clods in heavy soil.

Water for Stock.

One of the most difficult problems which has of late been proposed to us comes from Colorado. It is "how shall we best procure a supply of water for our stock; wells 50 to 100 feet deep, wind-power precarious?" Here is a difficulty which presents but one solution, and that is, storage of the water to tide over the temporary failure of the power. Steam-power is of course out of the question; animal-power is too costly, and needs supervision, and noth-

West, and many districts in the East suffer for want of water, and yet an inexhaustible supply exists everywhere beneath the surface. We would suggest the least costly wells; the Jilz auger well, for instance, which can be bored from three inches to twenty inches in diameter, can be tubed cheaply with wooden curbs or galvanized iron pipes, and which cost about one dollar a foot to sink. These wells, where water lies over 25 feet from the surface, must become the mainstay of the western farmer. Where water is near the surface, either this well or the common drive-pipe well may be cheaply used. The power used must be the wind, and a self-regulating wind-engine, which will run day or night, should be used to raise the water into tanks or cisterns upon elevated ground, where it may be stored, and from which it may be carried wherever it is required. The accompanying illustration represents the method used upon Beacon Stock Farm, Northport, N. Y., for providing a permanent supply of water for the stock. It is placed where the water can be used upon the road through which the cattle pass, or in fields upon either side of the road. A "United States Wind-Engine" raises the water from a well into a tank of cypress wood. The tank holds about 10,000 gallons, and the overflow only is used, except when the supply is short. Then there is the stock on hand to draw from. It is rarely that 24 hours pass without sufficient wind to replenish the tank, when it is once full. Another instance is known to us, in which a farmer in a Southern State, at a cost of only \$400, erected a wind-mill, dug a well, built a tank in an elevated part of the farm, to hold 60,000 gallons of water, and laid pipes to convey the water to his garden and stables. The wind-mill pumped 10,000 gallons in 24 hours. This seems a large quantity of water, but it is only seven gallons, about two pailfuls, per minute. This quantity of

A Handy Wagon-Jack.

On a recent visit to Beacon Farm, we noticed a wagon-jack of very simple construction,

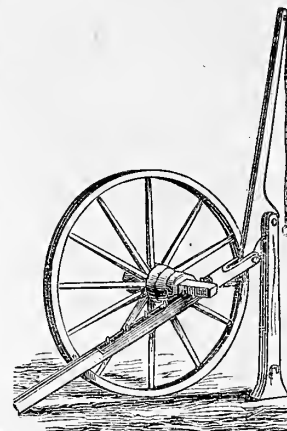

Fig. 1.—JACK CLOSED.

which we here illustrate for the benefit of our readers. It consists of an upright support, to which is jointed in a peculiar manner an arm or lever. To the shorter end of the lever is jointed an arm, considerably longer than the upright support, to which is bolted an iron plate, furnished with short spikes.

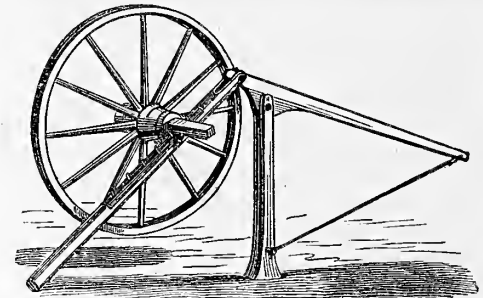
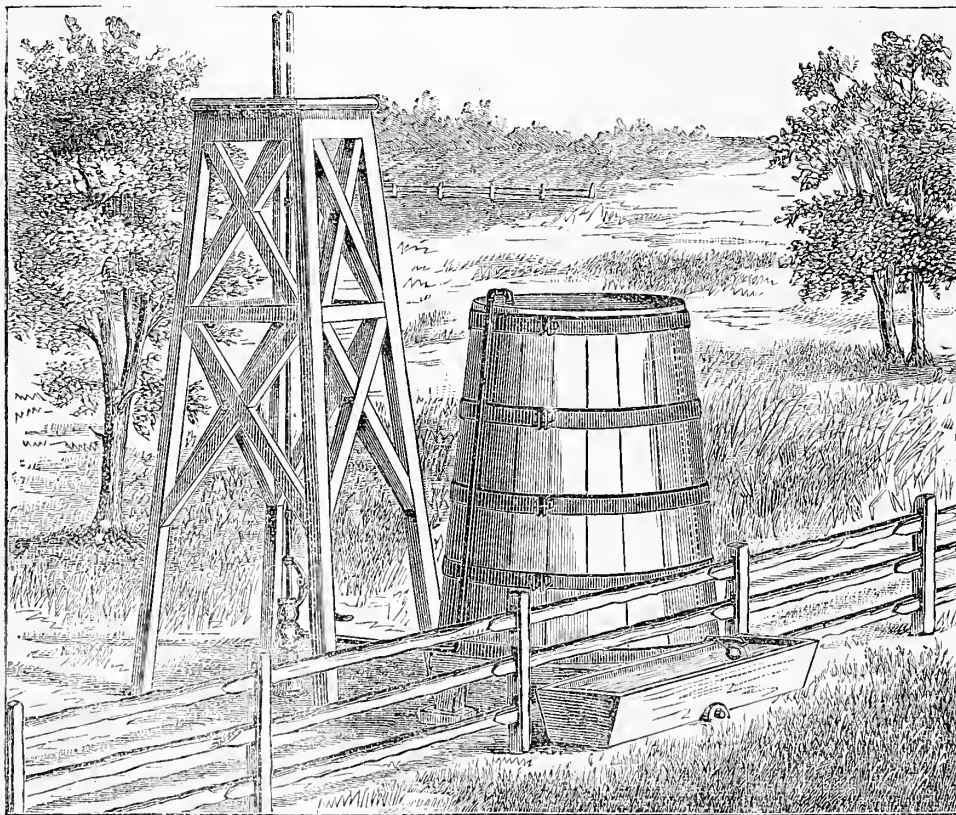

Fig. 2.—JACK OPEN.

When in use, the spiked arm is placed beneath the axle of a carriage or wagon, the axle resting upon the spike that may be most convenient for the purpose. In this position the lever is raised upward, as seen in fig. 1. When the lever is brought downward, as in fig. 2, the axle is raised. By attaching a cord or chain to the lever, and hooking it to the upright leg, the wheel remains elevated. There is no patent-right attaching to this useful contrivance.

A Western Cattle Barn.

"Subscriber," asks for a plan for a stock barn, costing from \$1,500 to \$2,000, in which he may feed young cattle, until they are ready for market. From our own experience in feeding young stock, we suggest the accompanying plan of arrangement. To feed cattle profitably, they need to be comfortably placed, kept quiet, with every facility for getting in and out of their stalls, and to have no annoyance or excitement. For the convenience of their keeper, the barn or stable in which they are kept, needs to be arranged so that there is the least possible labor, in storing and distributing their feed, in feeding, watering, and cleaning them, and in removing the manure. As has been before stated, we prefer the method of accumulating the litter and droppings of the cattle, and feeding them in stalls, in which they can remain loose; or if they are tied up, to keep them in such a manner, that they can have plenty of straw under them to keep them clean, and to remove the bedding only when they are turned out in the spring. In this plan there is a vast saving of work of a disagreeable character through the winter, and when the manure is moved in the spring, it is in far better condition than if it had been exposed to the snow and frost for several months. In laying



PUMP AND CISTERN FOR WATERING STOCK.

ing remains but the wind, which works night or day without attention, and which must be utilized when it is available, to store up a lasting supply. The difficulty exists all over the

water will provide for a large number of stock, and several days supply are on hand to meet an emergency. We believe these instances meet the cases of our Colorado and other enquirers.

out a cattle shed, we should always do it with this object in view, even in the West, for although a Western farmer may scorn to think manure of any value, there will be no shed built this year which will be worn out before the time comes in which manure will be as highly thought of by the Western farmer, as it is now by the Eastern one.

Figure 1 shows the ground plan of the

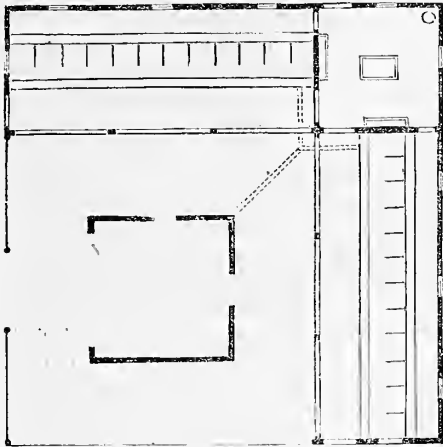

Fig. 1.—PLAN OF CATTLE BARN.

proposed stable. It is made in two wings, facing the Northeast and Northwest. At the North corner is a square room which may be used as a store room, feed room, or for any other purpose. From this room passages run right and left, from which the cattle are fed. These passages may be 6 feet wide. There should be as many windows in these passages, as shall give needful light and ventilation through the stable. The stalls with racks or feed troughs opening into the passages, are in the rear, and the doors from the stalls open into the yard. These doors should hang upon rollers, and when rolled back, at least one half of the front of the sheds should be open. The yard will face the South and East, and should have a manure vault in the center, into which drains (shown by the dotted lines) should carry off the liquids from the stable. The yard may be fenced in, and feeding racks may be placed around it, in which in fine weather fodder may be given to the stock. Fig. 2 shows the elevation of the sheds, and the arrangement of the yard. The upper story is for storing hay, and at the center of the building, a windmill should be erected, to pump water for the stock from a cistern or well beneath it, or it could furnish power to cut feed if necessary. The extra cost of these conveniences, will pay for themselves

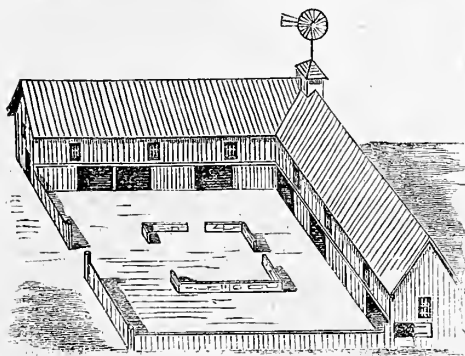

Fig. 2.—ELEVATION OF BARN.

in the course of one season, in saving of labor and in growth of the stock. A trough of water should run through every stall, so that the cattle may be watered when required, without being removed or unfastened. The cost of a shed, such as is here described, 200 feet long,

20 feet wide, and 18 feet high, with all the conveniences mentioned, and substantially built and painted, should not be more than \$1,500, and it may be built for much less.

Tightener for Wire Fence.

As fences made of wire are more used, it becomes all the more necessary to have a suitable method of tightening the wire. The usual manner of straining the wire in one direction only, tends to draw the straining post out of its position. But if the roller upon which the wire is wound, strains from both directions, the force is equalized so far as the straining post is concerned, and it is necessary only to have the end posts well stayed. In the method shown in the engraving, there are two posts fastened together with a cap piece, and set firmly in the same hole. Each post is well stayed with a brace, which supports it in the direction in which the wire is drawn. The posts are bored to receive rollers upon which the wires are wound. One end of each roller is made square, and somewhat larger than the round part. The holes in one of the posts are made square to fit the square ends of the rollers. A winch is also made to fit the rollers, and the wires are tightened by turning the rollers with the winch. One wire is wrapped from above, and the other from beneath the roller, so that both are tightened

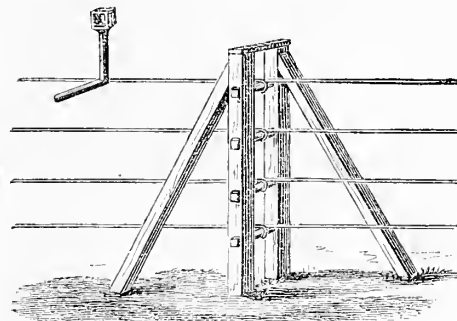

TIGHTENER FOR WIRE FENCE.

at the same time. When the wires are drawn tight, the square end of the roller is driven into the square hole in the post, and the rollers are firmly held.

A Cement Roller.

Now that the sowing of fall grain is at hand, the attention of farmers is turned towards rollers. The use of the roller is too much neglected. A considerable portion of the fall wheat crop is sacrificed every season by broadcast sowing, imperfect harrowing, and the want of a compact, firm seed-bed. The wheat plant needs a solid stratum of soil wherein to push its roots, and a somewhat rough surface is an advantage to it. There are cases in which the use of a drill is not possible, and where broadcast sowing is unavoidable. In such cases especially, and in all others, the use of a corrugated roller, such as is here illustrated, will be found profitable. It will be found more useful than the smooth roller, even when the drill has been used. A smooth surface favors heaving by frost, and winter-killing. If such a roller, as is here described, is drawn across the field in an east and west direction, leaving small ridges, a great protection will be afforded to the wheat when the ground is bare of snow in the winter, and frosty nights are followed by sunny days. The ridges will be exposed only upon one side to the sun, and the

low elevation of the sun will prevent all but the tops of the ridges from being thawed. The north side of the ridges will remain frozen, as also will every hollow, and in these the plants will be safe. When the usual north wind blows, these ridges will intercept the drifting snow, and each hollow will remain filled with a protecting covering. We have found this plan of drilling wheat in the direction of East and West to be a great advantage in this way, and if the ground had been rolled with such a roller as is shown in fig. 1, the advantage would

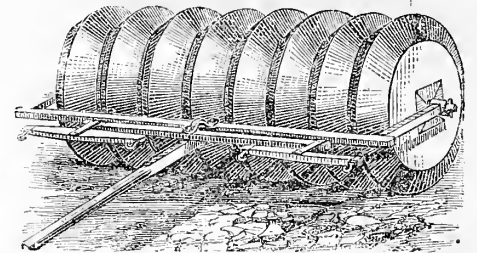
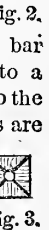

Fig. 1.—CEMENT ROLLER COMPLETE.

have been greatly increased. The roller consists of segments eight inches thick, made of concrete, or a mixture of one part of cement and four parts of sand. The diameter of the segments is 30 inches. They are molded in the shape represented at figure 2. The center, in which the axle works, is made of four pieces of hard wood, cut so that the wear is upon the ends of the fibers, and which are channeled upon their outer edges. The centers are fastened in the mold and the cement is cast around them, where it sets and hardens, holding them firmly. Figure 3 shows the form of the centers. The segments are strung together upon an axle, consisting of an iron bar one inch in diameter, which is fitted into a frame. A tongue is fastened and braced to the frame in the usual manner, and two horses are required to draw it. Each segment will weigh over 300 pounds, and the eight, with the frame, will weigh nearly 3,000 pounds, which will give a compressive force of about 375 pounds for every square foot of bearing surface. This pressure, with the peculiar form of the segments, will render this roller a most effective clod-crusher



A Mink or Rat-Trap.

Although vermin may be kept out of a poultry-house by constant watchfulness, yet in

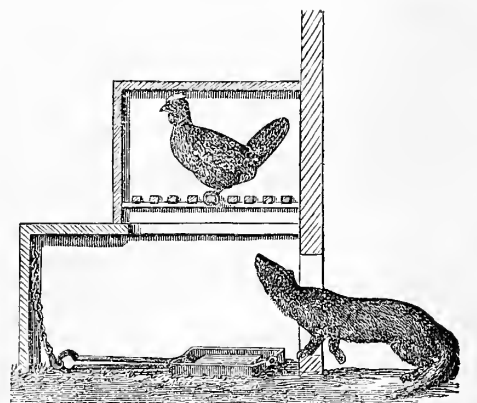

Fig. 1.—SECTION OF MINK-TRAP.

an unguarded moment their greater perseverance will frequently get the better of our care, and accidents will happen. It is therefore well to use traps occasionally, to kill off vermin, notwithstanding we may believe our

poultry-houses effectually guarded. A successful method of trapping marauding animals is here shown. Against the usual entrance to

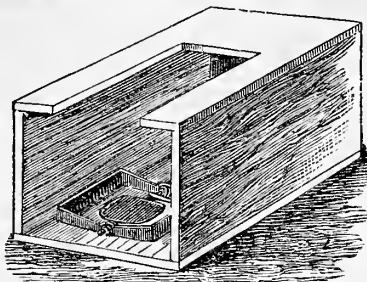

Fig. 2.—LOWER PART OF THE TRAP.

the house, which is left open for the purpose, there is placed and fixed inside a box, from which the end has been removed, and from the top of which a piece has been cut, as represented in fig. 2. A steel-trap is set in this box without any attempt at concealment. Boldness in this case is the most successful plan.

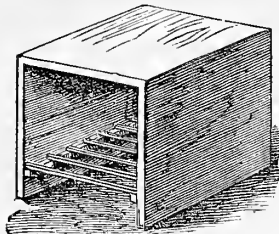

Fig. 3.—BOX FOR THE BAIT.

Above the hole in this box is placed a smaller box provided with a false bottom of laths, an inch apart, shown at fig. 3. A chicken is put into this box. The consequence of an attempt to take the chicken, by a nightly prowler, whether cat, dog, mink, rat, or skunk, is readily foreseen.

Kilns for Burning Tiles.

After tiles have been molded by means of any of the machines, designed for that purpose,

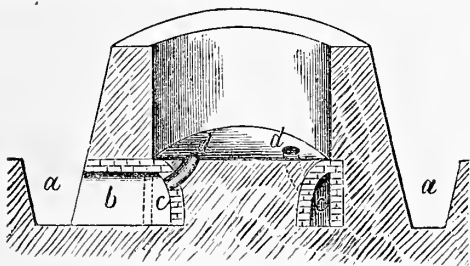

Fig. 1.—KILN FOR TILE-BURNING.

and partly dried, it is necessary to roll and straighten them. This should be done, because in drying many of them will become warped and crooked, and a secure drain cannot be made with ill-shaped tiles. A thick slab of stone or hard wood, should be procured, and a smooth hard wood stiek, a little smaller than the inside diameter of the tiles. The stick is put through the tile, which is then gently rolled back and forth upon the slab, until it is straightened. If the edges of the tile need trimming, this should then be done, so that a close joint may be made. After a little more drying, the tiles may be baked, or if the fire is carefully started in the kiln, they may now be baked at once.

There are various styles of kilns or ovens for burning tile, but for the purposes of the small manufacturer, who needs to burn not more than 100,000 in a season, the forms of kiln and oven here shown, will be suitable and very cheap. That of which a section is shown in fig. 1, may be built for \$40 or less. It consists of a circular wall of beaten clay, 7 feet high, 4 feet thick at the bottom, and sloping outside only, to 2 feet in thickness at the top.

This wall forms a round structure 11 feet in diameter. Outside of it is dug a trench, from which the clay may be taken to make part of the wall, 4 feet wide at the top, narrowing to 18 inches wide at the bottom, and 3 feet deep. This is seen at *a*. From this trench there are three fire holes dug, one of which is seen at *b*, communicating with another trench inside the walls, seen at *c, c*. This trench is bricked over, and has three flues passing from it into the floor of the kiln. These flues are shown at *d, d*. Brick-work fire places are built in the fire holes, with fire bars or grates in them for the fuel, and doors or dampers of burnt clay or cast iron, should be provided for them. Either coal or wood may be used to heat the kiln. A doorway is made through the wall, through which to carry the tiles. This door may be bricked up when the kiln is filled. A rough shed should be built over the kiln, high enough to be secure from the fire, for protection against the weather.

The tiles are placed in the kiln upon their ends, lest the weight of the upper tiers should crush the lower ones. The small tiles are put inside of the larger ones, to save space as much as possible. In placing the tiles, narrow lanes are left between them, radiating from the flues from the fire places, and these are broken in each tier, so that the flame and heat from the fire, shall be made to strike every tile. With proper care in filling the kiln, a more even burning will be made, and there will be but few imperfect tiles. There are two dangers to avoid, one is under baking, and the other is over baking. It is well to have two or three test holes made in the walls, and to lay a tile opposite each hole, so that it can be lifted out on the end of an iron rod and examined, and the fire regulated accordingly. There should be one test hole for each fire hole, or for that part of the kiln subject to each fire hole. These holes are closed with a piece of soft clay. When not sufficiently burned the tiles are soft, of a pale color, and will not ring clearly when struck together. Such tiles should never be put into a drain, or if used should be put by themselves at the head of a drain, and never where their failure would stop a current of water. In a year or two, or perhaps less, they will crumble down, or flake off until they are destroyed. Perfectly burnt tiles are bright red in color, and ring clearly when struck. When over burned they are glassy, brown or black in color, deformed in shape, cracked, and run together in masses. For profitable results, therefore, the important business of burning should be cautiously and carefully done. The

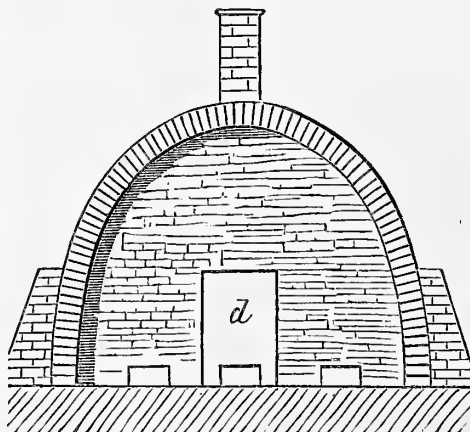

Fig. 2.—PERMANENT TILE-KILN.

fire should be started gradually. If the tiles are damp, they should be warmed up slowly, and the fire should not be given headway for

two days. It should then be kept steady until the burn is complete, when the fire holes should be luted up with clay, and the kiln allowed to cool gradually. Fifteen days are sufficient to fill a kiln, burn the tiles, cool off, and empty it.

Figure 2 shows an oven which is more economical of fuel, than the one just described, and which may be kept more under control. It is also a more permanent structure. It is an arch of brick-work, 14 feet long, 8 feet high, and 11 feet wide in the clear. The wall may be built one brick-length, or 9 inches thick, and should be supported by buttresses, as shown in the illustration. It may be built half this thickness, if supported by 4 inch iron bands, 3 feet apart. The bands should be secured to stones in the foundation of the wall. Fig. 3 shows



Fig. 3. GROUND PLAN.

the ground plan of the oven. The chimney is placed at one end of the arch, at *a*; *b* is the body of the oven, *c, c, c*, are three fire places, 18 inches wide, 12 inches high, 30 inches long, and made 9 inches below the surface of the floor of the oven. From these fire places, flues 9 inches deep are made in the floor of the oven, converging toward the chimney. The chimney space is about 16 inches square, and vents are made in the wall, to communicate with the chimney space. A door, *d*, fig. 2, is made in the front of the oven, through which the tiles are put in, and when filled, an open wall of loose bricks is built up in front of them, and over the ends of the fire holes, to protect the first courses of tiles from the full force of the fire, and to spread the heat regularly through the whole mass. This wall is shown at the dotted line, *e, e*, fig. 3. A quantity of bricks set upon end are placed upon the floor of the oven, and the tiles are ranged upon their ends upon the bricks, the small ones inside of the large ones, as previously described. It is necessary to place the tiles so that the fire may reach every one, and yet that space may be economized. The success of the burn greatly depends upon this.

Tobacco in the Connecticut Valley—Special Crops.

In a recent trip up the Valley of the Connecticut, from its mouth to St. Johnsbury, we noticed the diminished size of the tobacco fields in Connecticut and Massachusetts. This is attributed to the low price of the weed, the lateness of the season, and the difficulty of getting plants to set. It is estimated that less than half the usual area is planted with tobacco the present season. There has been an over-production in past years. Tobacco in former years paid so largely that the area devoted to it on each farm has gradually increased, and new competitors have each year crowded into the business. We saw the evidences of the extent of the business in the new and large tobacco sheds and drying barns, and in the boxes and bales at the depots. The tendency of this and other special crops, we think, is not favorable to good farming. The tobacco grower concentrates all his energies upon this one crop. The few acres devoted to it of course are enriched, but as a rule all the rest of the farm is robbed to sustain the tobacco field. No brute will eat tobacco, and no manure from the crop, but the stems, goes back to the field. The

dairy dwindles, and the meadows yield diminished hay crops. Less and less manure is made, grain is not cultivated, no beef or pork, sheep or lambs, are reared or sold, and nothing of importance is sold but tobacco. Fertilizers are purchased—stable manure from the cities, and fish-scrap from the oil factories upon the coast, but nothing receives the benefit of the manure but the tobacco field. There may be exceptions to this rule, but there can be no doubt that this is the general tendency. This appropriation of capital and labor to a crop that has no alimentary value, of course affects the household markets in all the cities and towns in the region. Food is unreasonably dear. The acres that ought to be growing fruit and vegetables for human sustenance, are grazing the tobacco worm, and farmers are laboring to check its depredations. The meadows where cows should graze, are growing barren for want of manure, and those who live in the villages of this valley are paying an average of about eight cents a quart for milk. The pastures that might be kept in good heart perpetually with sheep, run up to brush and briars, and the dwellers there pay twenty-five cents a pound for lamb, and go without mutton six months of the year. The orchards are running out, and they import apples by the carload every year into a region entirely congenial to this fruit. With every facility for market gardening and truck farming, they empty long trains from New York, burdened with the products of Delaware and New Jersey soil, and pay big prices for the privilege. This may be economy, but we are not able to see it. We want well cultivated farms, as a means of giving the towns and villages cheap and wholesome food in great variety, and any special crop that defeats these ends is to be deprecated.

Wooden Hangings for Barn-Doors.

M. O. Barton sends us drawings and a description of the wooden hangings of his barn-doors, which have been in use for three years, and which, he thinks, are greatly preferable to iron ones. The rollers are turned out of a piece of seasoned hard maple, 4 inches thick; they are 4 inches in diameter, $\frac{3}{4}$ of an inch thick, and the axles are an inch thick, and $\frac{3}{4}$ of an inch long. They are shown at *a* in fig. 1. The track *b* upon which they run, is of hard timber, dressed perfectly smooth and straight, $2\frac{1}{2}$ inches wide and 2 inches thick, and is bolted to the girt, *c*; *d* is the edge of the boarding of the barn, upon which the track is made to rest. Ribs, *e, e*, are nailed firmly to the track, making a groove, in which the wheels run. These

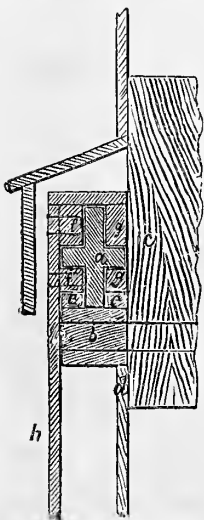

Fig. 1.—SECTION.

ribs are $\frac{3}{4}$ of an inch wide and $\frac{3}{4}$ of an inch thick. The top cleat of the door is $1\frac{1}{2}$ inch thick and 3 inches wide, with grooves cut the thickness of the wheels, or half the thickness of the cleat, and inch-holes are bored through the rest of the thickness of the cleat, to receive the axles of the wheels. This cleat, in which the holes and grooves are cut, is shown at *f, f*.

A strip, $\frac{3}{4}$ of an inch thick, is then bored with one-inch holes, to receive the other ends of the axles, and is nailed firmly to the cleat of the door. This is seen at *g, g*. The door itself is shown at *h*. Thus the wheels or rollers are inclosed in the upper cleat of the door,



Fig. 2.—CLEAT AND WHEEL.

and when well soaked in oil, and covered with tallow, as well as the grooves and holes, in which they run, they travel back and forth smoothly and noiselessly. Fig. 2 shows the section of the wheel from above; *a* the cleat of the door, in which the groove and hole are seen, and, *b*, the strip nailed to it; *c* the wheel. The door is covered with a cap to protect the hangings from the weather, as in fig. 1.

Inspection of Butter.

Beef, flour, and pork are inspected, and the inspector's brand gives each a standing and character in the market, that is a guarantee of value to the purchaser, and a surety to the packer that he is getting whatever price the grade of his product deserves. But the dairyman labors under a disadvantage. If he makes a most excellent article, it is classed in the market according to its locality, and if the reputation of the locality is not equal to the intrinsic worth of the article, he gains nothing for his extra care and skill, and gets only the current price for the class of butter to which his shipment belongs. Thus if Western butter—as an unsavory reputation in the Eastern market, a shipment from a Western dairyman, unless he has already made a reputation for himself, is sold as Western butter at the regular quotations, which, as we write, are 10c. a pound below those for the product of New York State. Yet the best butter we ever tasted was from a Western dairy. Indeed we ourselves have had the mortification of having butter sold in the New York market, at several cents a pound less than we could readily get at home for it, because it was not from the State of New York, although when afterward put up in "Orange County pails," it could be as easily sold, when its quality became known, as Orange County, at the highest rates going for that class of butter. A large dealer once told us, that he would touch nothing that was not from Orange County, N. Y. Now all this is an injustice to other dairymen, and really amounts to a premium upon carelessness and poor quality. Why should not butter be inspected and sold upon its merits, as first, second, or third quality, and why should not a Western dairyman, who may have equal facilities and skill with an Eastern dairyman, be as well paid for his product? In short, why should not the dealers in the New York market, sell all good butter for the same price, irrespective of the locality in which it is made? It is well known that they do not, and that an unwarrantable and unjust discrimination is made against Western butter, simply because it is Western. There is now a Produce Exchange in New York, in whose power it is to remove this ban upon butter that is foreign to Orange County, or those chosen places, which it is the custom to include in that elastic appellation, and to put it squarely upon its merits. We bring this matter to the notice of the Granges, that through them such a pressure may be brought to bear upon the dealers, as shall force them to do equal justice to all their clients, whether

they happen to live in New York, Ohio, Indiana or Michigan. As good butter may be made in any one of these States, as in another, and while we point out this fact, we would impress upon our Western readers the necessity of bringing up the quality of their product, so that when it comes to be graded upon its merits, by competent and disinterested inspectors, it shall rise far above its present low estate.

Cider and Cider-Vinegar.

To procure either cider or cider vinegar of the best quality, care and skill are required in the manufacture. Some too economical persons, thinking that nothing should be wasted, are now engaged in gathering all the wormy and defective apples that fall from the trees, and consigning them to the cider-press. As new cider this questionable liquid is sold to the unsuspecting consumer for fifty cents a gallon. It however bears no comparison with cider that is carefully made from sound apples, and can not be made to produce a well-flavored vinegar. It would be better economy to feed all such apples to the pigs, for the first requisite for good cider or vinegar is sound fruit. All bruised, wormy, or defective apples must be discarded, if perfection is desired in the product. The next consideration is the mill and press, and the method of using them. In districts where timber is plentiful, and the necessary mechanical skill can be had, an improvement upon the old-fashioned mill and press is probably the best machine that can be procured. It is made wholly of wood, and no iron comes into contact with the crushed fruit. The timber should be sugar-maple or birch. These are free from the tannic acid, which renders oak objectionable, and stand wear and tear sufficiently well. The crushers are made of solid blocks, carefully seasoned under cover, so that they are free from cracks. They should be about 18 inches in diameter, and about two feet long. They should be turned perfectly cylindrical in a lathe, and deep, broad grooves cut lengthwise in them, so that the teeth of each, which are left projecting, fit accurately into the grooves of the opposite one. Four inches wide and three deep is a proper size for the grooves. This work should be done by a millwright, or a carpenter used to doing mill-work, as it is a somewhat difficult job. Upon the perfection of the rollers or crushers, the yield of cider greatly depends, as the apples must be reduced to a pulp, before all the juice can be pressed from them. The rollers are furnished with axles, also accurately turned, and are fitted into a frame, which is shown in fig. 1. This frame consists of a strong bottom of plank, four inches thick, preferably of maple, closely jointed and matched together. This is raised about 20 inches from the ground, upon a stout frame, and is pinned fast to heavy posts, set a few inches in the ground, so as to be immovable. A raised border is placed around the bottom planks. A cross-frame is built across the center of the bottom, into which the axles of the rollers are fitted, and to which they are secured by short blocks, pinned or bolted to the frame-work. The lower axles of the rollers fit into holes made in the bottom planks. The axle of one roller is lengthened, and attached to a horizontal arm, to which the horse may be hitched. A hopper is built at the rear of the crushers, to receive the apples, and feed them to the crushers. Fig. 1 sufficiently explains all other details. The press is shown in fig. 2.

It is an improvement upon the old-fashioned heavy press, which is made from the trunk of a large tree, and frequently required the trunk of another large tree as a support for it, and which

channel, two inches wide, and one inch deep, is made to the front, to carry off the juice as it flows. A piece of board is laid over this channel, and the floor of the press is covered with

several excellent cider-mills manufactured by different parties East and West, which are convenient for those who have but few apples, or who have enough to keep one hand-machine going. One of these, known as the Keystone Cider Mill, is an excellent one. We have made cider and vinegar of a very light color in one of these mills, as the pomace is exposed to the air only for a moment, as it falls from the grinders, and it is passed immediately under the press. No straw is needed in using a press of this kind. When the juice is safely in the barrels, it needs close watching during the fermentation. It is best to keep the bung-hole covered, to exclude insects and the air. For this purpose a perforated bung is useful, in which a glass tube, an inch in diameter, (fig. 5,) may be inserted. The tube, 12 inches long, may be kept filled, which will prevent any access of air into the barrel. When the cider is to be kept for a length of time, this course is advisable. After fermentation has stopped, which may be seen by observing that gas no longer bubbles up and escapes through the glass tube, the cider should be carefully drawn off into fresh, sweet casks. The barrels should then be stored away in a place where the

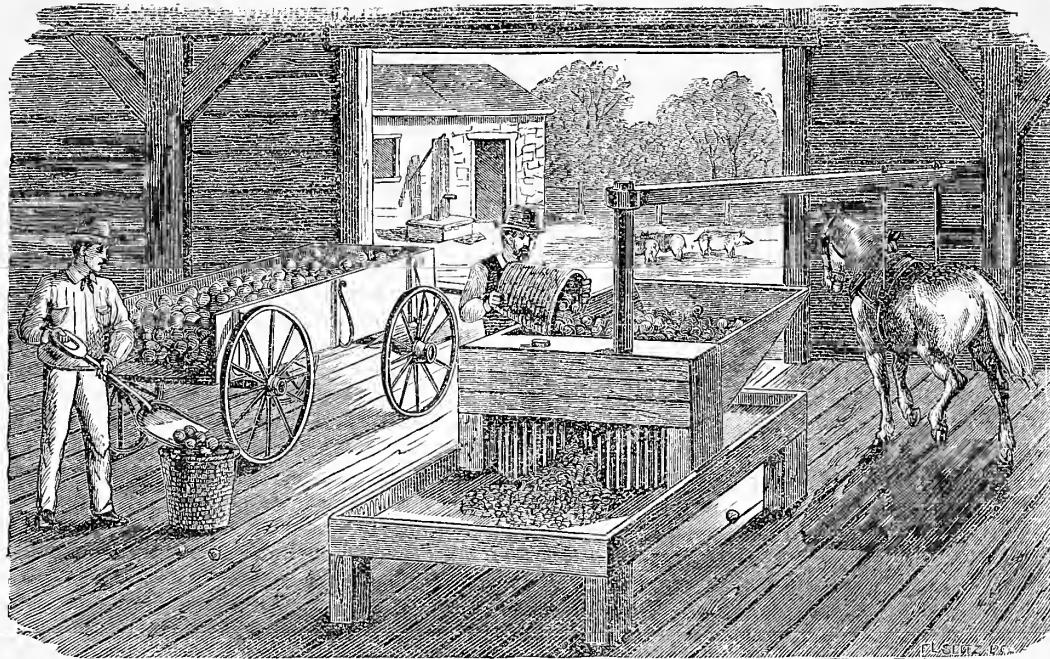

Fig. 1.—CIDER MAKING—CRUSHING THE APPLES.

is weighted at the end with a clumsy screw, a foot in diameter, and a ton of stones in a huge box. If any person supposed all this huge weight saved labor, he was greatly mistaken, because before a pound of pressure could be exerted upon the pomace, the whole weight of beam, screw, and stone

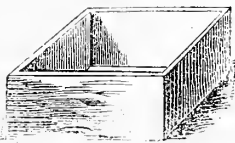

Fig. 3.—BOX.

must be raised. In this ancient machine the weight, which causes the pressure, is raised, while in the one here illustrated the pressure is brought to bear directly. The immense weight of the old press is, therefore, not only useless, but a hindrance. It is needless to give any description of what is so clearly shown in the engraving, further than to state that the material of the press is similar to that of the mill, and that the screw may be of wood, preferably of beech, but is better, and in most cases cheaper, of iron. The screw should be lubricated with hard tallow, ground up smoothly with black lead. As the apples are ground, the pomace should be put into the press immediately, if light colored cider or vinegar is desired. If a deeper color is wished for, it can be procured by exposing the pomace in the mill to the air, while one batch is pressing. A wooden scoop should be used to lift the pomace. No iron should touch the crushed fruit or juice during the process, if excellence is wished for. In building up the "cheese" in the press, it is better to use a small square frame of boards in the center, by which an interior space is left in the mass of pomace, through which the juice is expressed more readily, than if the mass were solid. The use of this small frame will obviate the necessity of a second pressing. The frame, fig. 3, is placed in the center of the press. From this center a

clean, straight rye-straw, leaving the ends projecting at each side, which have to be turned over the first layer of the pomace. This prevents the pomace from being squeezed out when it is pressed. When the first layer is finished, and the straw is turned upon it, it appears as in fig. 4. This process is repeated, until the press is full, when the pressure is applied gradually, so as not to burst the cheese. The juice runs through a filter of cut straw into a vat, from which it may be dipped or pumped into the barrels. It is well to have a strainer of hair-cloth in the funnel, or across the mouth of the pail, as the barrels are filled. In all these processes the utmost cleanliness should be

temperature is even, and the bung-holes tightly closed. If it is intended for vinegar, empty vinegar-casks may be used. The bung-holes should be left open, and kept covered with a piece of fine wire gauze, so as to admit the air. After a time the vinegar will make, and should be again drawn off into clean casks, without disturbing the sediment. If the sediment should become disturbed, the

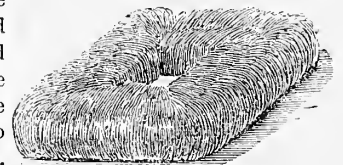

Fig. 4.—THE CHEESE.

observed, if a good product is wished for. For those who find it more convenient to use a manufactured mill, that known as Schenck's Apple and Grape Grinder, which is able to grind 200 bushels per hour, may be desirable. There are

vinegar is never perfectly clear afterward. To make vinegar from cider in the most rapid manner, the building must be heated to about 70°, and the liquid frequently exposed to the air, by drawing it from one cask to another.

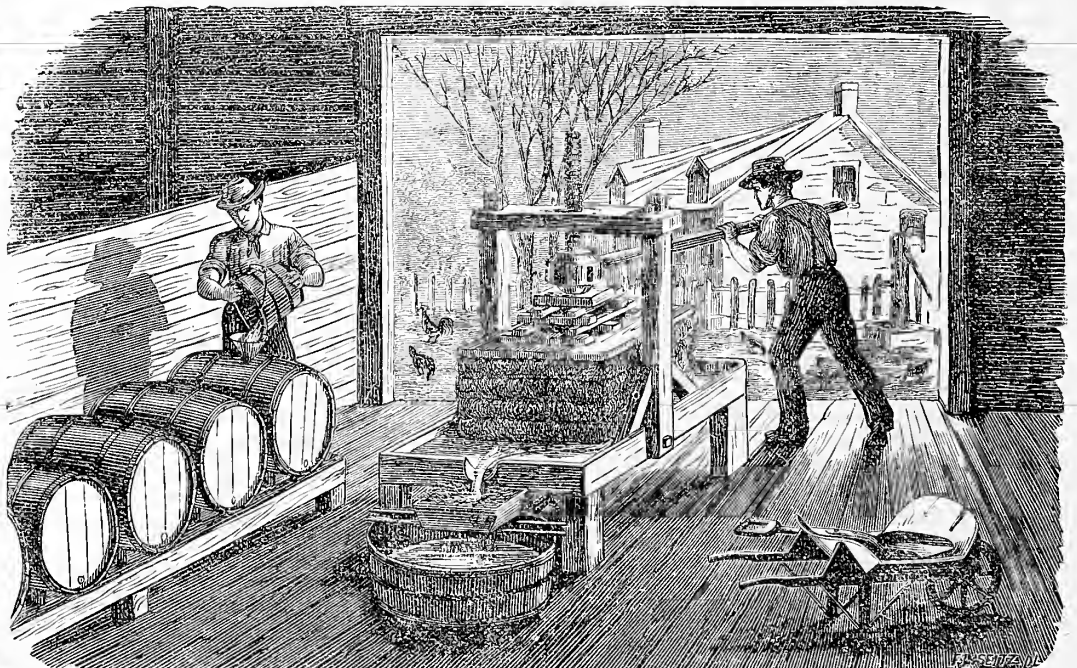

Fig. 2.—CIDER MAKING—THE PRESS.



Fig. 5.

The Broad-leaved Acanthus.

Within a few years the taste for plants with handsomely formed and stately leaves has much increased. We do not now refer to leaves attractive for their color, but to those of

high, are white or lilac, each in the axil of a large leafy bract. The only plant of this we have seen is one which Messrs. Olm Bros. received with other things, and treated as a greenhouse plant. As far as can be judged from a specimen grown in a pot, the European ac-

The stem is one to two feet high, and bears at the top a large, much divided, panicle of small rich crimson flowers. The plant is as yet little known in this country, but at the Exhibitions in England, this summer, it has attracted much attention, and received high commendations.



THE BROAD-LEAVED ACANTHUS.

marked outline and habit. Plants of this class are for convenience called sub-tropical, though many of them are not natives of warm climates—sub-tropical being a convenient term for that style of gardening, which depends upon beauty of form rather than color for its effects. Among the plants that have come into prominence for this use are several species of *Acanthus*. This name is the Greek word for thorn slightly modified, some of the species being very thorny; and we are quite sure that the greatest stickler for common names will prefer it to "Bearsbrech," the name given to one species in England. The Spiny Acanthus (*A. spinosus*) is the plant that is said to have suggested the idea of the ornamentation of the Corinthian capital; the story goes, that Callimachus, the architect, was in great trouble how to finish off the capitals to his columns, and as he was pondering upon the matter in the garden, his eye fell upon a jar, around which Acanthus leaves had grown in the most graceful manner. The largest and finest of all the species used in European gardens, is called *A. latifolius* and *A. Lusitanicus*, but it is probably a variety of *A. mollis*. It is a fine, bold plant, with dark green leaves of pleasing outline, as shown in the engraving. It is said that well established clumps of this form a dense mass of fine foliage three feet high, and five feet across. The flowers, which are upon a long spike about five feet

counts are not overdrawn. It is perfectly hardy in England, and we hope it may prove so here, as it is a fine plant for the decoration of large gardens. Only two or three days before his sudden death, the elder Mr. Olm came to see us in reference to the specimen, which he had sent us for the purpose of engraving.

The Palmate Spiræa.

There are certain genera of flowering plants so large already, that we always dread to see a new species added to the list. This is the case with *Spiræa*, of which there are more than one cares to keep the run of, and with the shrubby ones at least, half or more of the list might be dropped out of cultivation without detriment. Therefore, when we saw the *Spiræa palmata* announced in the foreign journals as a new acquisition from Japan, we did not feel very enthusiastic over the matter, notwithstanding all the praise bestowed upon it. Last year we received a plant from Mr. Chitty, of the Bellevue Nursery, Paterson, N. J., and are forced to admit that it is a valuable addition to our garden. This is not a shrubby species, but a herbaceous one, that reminds us, as to its foliage, of the old "Queen of the Prairie," *S. venusta*. The leaves, as its specific name indicates, are palmately-lobed, and the lobes are sharply serrate.



THE PALMATE SPIRÆA.

With the Queen of the Prairie *Spiræa*, and others related to it, the trouble is that the flowers in the cluster open unevenly, so that by the time the outer ones in the panicle are well opened, the central ones have already dropped their petals, and taken on a seedy look. Whether this will happen with the Palmate *Spiræa* we cannot say, as our only flower-cluster was sacrificed for the sake of an engraving. We have no doubt that it will prove hardy here, as our plant stood out all last winter without protection, and came up strong this spring.

Onions Sown in Fall for a Spring Crop.

BY PETER HENDERSON.

It has long been a practice with market gardeners in the vicinity of New York, Philadelphia, and other large cities, to plant onion sets in spring for an early summer crop. These are sold in bunches in the markets in the green state; the sales are usually begun in this neighborhood about the first week in June, when they are only half grown, and continue to the middle of July. Onion "sets" have of late years been advancing so in price, owing to the increase in price of labor, that our market gardeners find that it hardly pays them to any longer buy their sets, and they are beginning to resort to another expedient to procure an

early crop, which is to sow the seed in the fall, winter over the young onions, or sets, in the ground, and allow them to continue their growth the next spring. This plan is not a new one, it being frequently followed in England, but in consequence of the severity of our northern winters, causing occasional failure, it has almost been abandoned.

But now, in view of the high price of "sets," it is again being resorted to, more care being observed to protect the young bulbs in winter. It is not easy to say, without some experiment, at what is the best time for sowing the seed, and the safest method will be to dry different dates, until it is seen which answers best. For this section, near New York, I would recommend the first, fifteenth and thirtieth of September. The ground should be prepared in the usual way, as if for sowing in spring, giving it thorough pulverization and manuring. The seed should be sown with a seed-drill, at distances of one foot between rows; this would take about 3 to 4 lbs. of seed to the acre. The kinds that prove hardiest are the red and yellow varieties. The soil must be thoroughly drained, either naturally or artificially, to prevent "heaving out" in winter. A Long Island market gardener informed me that even at the very low rates that green onions have brought the past summer, his fall sown crop netted him over \$1,000 per acre, the product in number of bunches being more than double that usually obtained from the planting of sets in spring. He sowed in a warm sheltered situation on rather light soil about the middle of September, thoroughly hoeing and weeding, so that he had a fine growth by the end of October. In December, before severe frosts had come, he covered the whole space between the rows two or three inches deep with leaves from the woods, choosing a day when snow was falling, so that the leaves were pressed down by the snow and prevented from blowing off. If the services of the snow could not be made available, branches thrown over the leaves would answer the purpose. When leaves are not at hand, salt or marsh hay, straw, or corn-stalks, would answer nearly as good a purpose, the object being to protect the crop from the severity of winter, as it is not sufficiently hardy to stand in our latitude without such protection. In all sections where the thermometer does not fall lower than 15 degrees above zero, such protection would be unnecessary. I would advise those residing in very cold localities, to experiment first with a small lot, until it can be ascertained whether they will winter over even with the protection of leaves or straw.

The Hollyhock Fungus—Cotton in Danger.

This disease among hollyhocks, which has spread in Europe with fatal activity, has already been briefly noticed. But little is known about it, save that it came from South America, and that it appears suddenly in widely separated districts, and causes the death not only of hollyhocks, but other plants of the Mallow Family. The disease shows itself in small spots upon the leaf, which, when magnified, are seen to be groups of minute fungi. The engraving here given, reduced from one published in a recent number of Gardener's Chronicle, shows the spots as they appear upon the leaf (A) of the common Round Mallow (*Malva rotundifolia*), and the fungus largely magnified. The long horn-like projections (B) are the hairs upon the mallow leaf. The spread of this pest seems to

be mysterious, it appearing at once in all parts of a large plantation; and yet Prof. W. G. Smith has entirely failed to propagate it, although he has wrapped the diseased leaves around the stems of healthy hollyhocks, and buried others in the soil at the root of the plant; this failure may be accounted for by the fact that the spores were not yet ripe and ready to germinate. Thus far no application of sulphur, or other fungus destroyers, have been of use, and the only known remedy is to root up every affected plant.

The venerable Mr. Chater, a distinguished florist, who has devoted half a century to the improvement of the hollyhock, and to whom we are indebted for the present perfection of the flower, may well be despondent at the loss of the favorites he has so long cherished. While this disease prevails, no malvaceous plants should be imported to this country from England or the Continent. Our importing florists should bear this in mind, and let all the new varieties of Abutilon, Hibiscus, and everything else of the Mallow Family, remain with the ocean between them and us. This warning should be heeded, for if the fungus is once introduced, it will no doubt prove a greater enemy to the cotton crop than all of its insect enemies together. As it, so far as known, attacks all of the Mallow Family indiscriminately, there is every reason to believe that cotton will prove no exception. Its introduction would be a national calamity, and one that can not be too zealously guarded against.



HOLLYHOCK FUNGUS.

Rose-Growing in Winter—Conflict of Opinion.

BY PETER HENDERSON.

The matter of growing Roses for winter-flowering is now engrossing much attention, and I have more than once written upon it in the columns of the *Agriculturist*; but the subject is now getting to be of such general interest in every section of the country where there are greenhouses, that anything that will tend to a further knowledge of the subject will, I know, be read with interest by many hundreds of your readers. There are three different systems in use; first, that of growing the plants in large pots, or tubs; second, planting out on prepared solid borders of soil, from 1 to 2 feet in depth, and another by planting out on raised benches or tables, in 6 or 7 inches of soil. Each of these systems has its advocates, who claim that one or the other is the best, and the novice in rose-growing (and it must be remembered that we have hundreds beginning every year) is puzzled to decide which system to adopt. I have tried them all with fair success in each, and have come to the conclusion that, taking

all points into consideration, particularly where Roses are not grown exclusively, but only form a part of the general stock, that the plan of planting out on raised wooden benches, in 6 or 7 inches of soil, is the most profitable. I am now preparing the center benches in two of my largest greenhouses, making a space of 600 feet long by 8 feet wide, or nearly 5,000 square feet, whereon to plant Roses. The plants used will be those struck from cuttings last February, and grown on in pots, so that by September they will be plants from 12 to 18 inches in height. The soil in which they will be planted is now being prepared, and consists of 6 parts thinly cut sod, from a rather heavy soil, to this is added 1 part rotted cow-stable manure, and 1 part sandy lime rubbish and oyster shells, all thoroughly chopped up and mixed together. The grassy fiber may hardly be decomposed before we use it, but that will matter but little, only it will be necessary to cover this compost when placed on the bench with an inch or two of soil, so that any of the sod roots that may be alive will be unable to grow through it. This soil will not be put on the benches before the middle of September, when the Roses, already prepared, will be planted about 12 or 15 inches apart. We shall use about 4,000 plants, which will be apportioned in number, as far as our knowledge goes of their merits, thus:

1,250 *Bon Silene* (deep carmine); requires the warmest part of the house.

1,250 *Safrano* (saffron yellow).

750 *Isabella Sprunt* (canary yellow).

250 *Douglas* (purplish crimson); requires the coolest part of the house.

250 *Duchess de Brabant* (salmon and rose color).

100 *Bella* (pure white).

100 *La Nankin*, new, (lower part of bud orange yellow, upper part pure white).

50 *La Jonquil*, new, (clear golden yellow).

Should no accident occur, we anticipate that this number of Roses so planted will average us 3,000 rose-buds per week from October 1st to June 1st. I need not detail here the after-treatment, that having already been fully done in my previous articles, other than to briefly say that a night temperature of from 55° to 65° must be steadily maintained, with a day temperature of 15° or 20° higher. The plants must be freely syringed at least once a day, but watered at the roots only when dry, and then freely.

This method of planting roses on raised benches necessitates their renewal at least once in every two years, as the soil in which they are grown becomes "washed out" by the frequent waterings; we ourselves intend to renew the soil every season. The roses planted in September will be flowered to their fullest extent during winter, until the first of June. Each plant will have then formed a mass of fibrous roots, so matted that the soil is held by them, and which can be lifted by passing a spade under them; when these are potted in pots or tubs suited to the size of the plant, no check to the growth is given. We lifted in this way from benches the past season roses which were four feet high by as much in diameter, planted them in pots 15 inches wide, with hardly the loss of a leaf. By lifting every season in June, the plants can be set out-doors, and the whole care of watering and syringing the greenhouse can be dispensed with for the three hot summer months; this is a matter of very great importance, for in most locations there is never water enough, and even if there is, unless it is unremittingly applied, the roses are certain to

be seriously injured during summer. To be sure, the labor of taking up the plants and potting them, and removing the old soil in June, and again replacing with the fresh soil in September, is a good deal of labor, but not half that of caring for the roses if they are kept under glass three months in summer, to say nothing of the unquestionable advantage of their having fresh soil to root in when again planted in September.

I have said that I consider this plan most profitable, particularly where roses are not grown as the exclusive stock. One reason for this is that the space under the benches can be utilized for many purposes. If the main angle of the greenhouse faces south, as ours does, we find that a bench placed on the south side under the main bench (which is 3 feet above the path and 7 feet from the glass at its highest point), about half way between the bench and the ground, can be made as available for many purposes as the benches or tables exposed to full light. Our lower benches are 18 inches wide, with a board behind wide enough to prevent the dry air from the pipes injuring the plants. On these underneath benches we have grown during the past season Ferns, Lycopodiums, Cape Jessamines, Irises, and all plants which naturally grow in the shade, and in spring, when these were disposed of, have again used this under space to sprout Sweet Potatoes, Dahlias, and Tuberoses. The space under the benches is usually only used by placing the plants on the ground floor, without any protection from the heat radiated from the pipes, and in consequence they soon present a wretched appearance; but when regular benches are constructed, as above described, the plants of the kinds suited to such treatment can be grown nearly as well as those exposed to direct light. It will be seen that this economy of space is of great importance, as it gives just so much more bench room, with no more cost in the labor of firing, of fuel, or of construction of the building. The under bench room used by us now is upwards of 10,000 square feet. If we used all solid benches on which to grow our roses, or other plants, this room would not be available. These wooden benches require to be replaced every 6 or 7 years, but their cost is nothing when compared to the saving made by using the space underneath.

Preserving Flowers—Winter Bouquets.

SECOND ARTICLE.

Last month, in giving an account of the method of preserving flowers by the use of sulphur fumes, a much older process was alluded to—that of preserving them by sand. This method has long been in use, although those who have practiced it have made a secret of it. At the Exhibition at the New York Crystal Palace, over 20 years ago, there was a case of flowers preserved in the greatest perfection, which attracted much attention. The writer at once guessed how the flowers were dried, and experimented sufficiently to show that his conjecture, that they were treated with sand, was correct. In drying flowers in this manner, they must be carefully surrounded by perfectly dry fine sand, in such a manner that they will hold their form, the pressure of the sand upon both surfaces being alike. Any fine clean sand will answer; it should be sifted to remove all coarse particles, and then washed in successive waters, until dust and all earthy and clayey matters are washed away, and the

last waters when poured off are perfectly clear. The sand is then to be dried, and then placed over a fire in a proper vessel, until quite hot, hotter than the hand can bear; and when cool it will be fit to use. After heating it should be used at once, before it can absorb moisture from the air. The vessel in which the flowers are to be dried, is of little importance where there are but few. We have had good success by taking a clean, thoroughly dry flower-pot, the hole in the bottom of which was stopped by a cork. This was filled a third full of the dry sand; the flowers set carefully in the sand, and then more sand slowly added, so as to surround and cover the flowers inside and out, and set in a warm place. At the end of 24 hours the cork was removed from the hole in the flower-pot, and the sand allowed to run out in a small and gentle stream. The flowers were left in the pot, perfectly dry. For operating upon a large scale, a box should be made or fitted for the purpose. A box with a sliding cover answers a good purpose, the bottom being taken off, and the sliding cover turned down to form the bottom. An inch or so from the sliding bottom there is placed a frame, upon which is tacked wire gauze of sufficiently large mesh to allow the flower-stems to be placed in it. If wire gauze is not at hand, a net-work of twine, or whatever else will answer the purpose, may be substituted. The box is to be filled with sand up to the level of this wire-gauze or other partition. Then flowers are to be placed in natural position, but not touching one another, and carefully surrounded by sand within and without. We have found a paper-funnel with a fine point, which lets the sand flow in a small stream, very convenient in this part of the work, as upon the care with which this is performed, will depend the shape of the flowers when dried. Often more than one layer of flowers may be placed in the box, the object being to have each one surrounded by a sufficient quantity of dry sand, to rapidly absorb all the moisture the flowers contain. All bell-shaped, funnel-shaped, and double flowers should be placed upright, and the sand so filled in, that they will not be crushed by pressure from without, or distorted by the sand within them. Flat or wheel-shaped flowers, like those of the Phlox, for instance, should be placed face downward. A little practice will enable one to find the proper position, it being borne in mind, that the object is to have the parts of the flower completely surrounded by sand, and still retain their proper form. It should be remembered that the flowers must be perfectly dry when gathered, as any dew or other moisture will cause them to become spotted and spoil. The flowers having been placed in the sand, and a layer of sand put on top, the box or other vessel is then to be set in a warm and dry place, such as back of or under a stove, or wherever there is a gentle heat. Those who have a greenhouse, will find the upper shelf, just below the glass, a suitable place. After the flowers have been in the sand for 18 or 24 hours, they may be taken out. The sliding bottom of the box is opened to let the sand run off gradually, and the flowers will be found dry and in their natural shapes and colors upon the partition of wire or other material. The flowers are now exceedingly fragile, and need the most careful handling. They must be taken up carefully, one by one, and if any sand remains, which does not fall off by gentle shaking, it is to be removed by brushing with a soft camel's-hair pencil; they are then put away in a box or drawer, where they will be free from

dust and dampness. Some prepare the sand after it has been washed and dried, by melting stearine with it. To three quarts of sand is added half an ounce of stearine (such as the hard or "star" candles are made of); the sand is placed on a stove in a glazed earthenware vessel, and when hot enough to melt it the stearine is added in small pieces, and the sand thoroughly stirred, the object being to coat each grain with a minute film of stearine. The use of stearine is to prevent the sand from adhering to the flowers, but if it has been properly washed, sifted, and dried, there is but little trouble. Almost all flowers may be dried in sand, but white ones have a yellowish tinge.

Florida Air-Plants—Epidendrums.

One who for the first time visits a fine collection of stove, or hot-house plants, is struck by the Epiphytal orchids, which appear to one who sees them for the first time in his life, as something quite wonderful in plant life. These Epiphytes, which in the moist woods of their native tropics, cling to the branches of trees, have in cultivation their natural habit imitated, and in the collections are grown upon billets of wood, pieces of cork, and the like, to which their roots affectionately cling. It is indeed strange to see plants not only growing without any connection with the ground, but flowering and producing a profusion of always curiously shaped, and often beautifully colored flowers. All orchids are not Epiphytes, *i. e.*, do not grow upon trees, but those which do are popularly called "air plants," as their nourishment must come from the air and the rains. These beautiful plants of the finer collections, are generally from tropical countries, and from the difficulty of obtaining them, and their slow growth, they are among the most expensive of all plants. All Epiphytes or air plants, are not orchids, as there are ferns and other plants, which grow in the same manner, one illustration of which was given in the "Long Moss," described and figured in July last. The vegetation of Southern Florida approaches a tropical character, and there are found there a number of air plants, including two orchids. These orchids both belong to the genus *Epidendrum*, (meaning—upon a tree), and form large clumps, which are attached to the tree by means of their clinging roots. Through the kindness of our friend Dr. Lungren, we received living specimens of both these species this spring; the small leaved one (*E. conopseum*), has not bloomed with us yet, but the long leaved one, (*E. venosum*) has flowered abundantly. The clump was fastened by means of fine wire to a block of wood, first putting a little moss around the roots, and suspended from a rafter of the greenhouse. It has had a daily sprinkling, and has flourished as well as if it had been at home. The engraving, reduced in size, gives an idea of the manner of growth. The stem is swollen at the base to form a kind of bulb, above which are two leaves, 4 or 5 inches long; the flower stem, 12 to 18 inches long, appears from between the leaves. After flowering, one to several offshoots are formed at the base of the old bulb, each of which develop two leaves, and during the season the stem below them forms a bulb, in which is stored sufficient nutriment to produce a flower-stem another year. Numerous flowers are distributed along the flower-stem, which, though not very brilliant, are exceedingly neat and interesting. The flower, the shape

of which is shown in the engraving, is about an inch and a quarter across; its three sepals, and two of its petals are alike in color, being a greenish buff with darker veins; the third and lower petal, called the lip, is in this as in other orchids, quite different from the other two; it is three-lobed, the side lobes embracing the stamen and pistil, and the middle lobe much larger than the others, spreading and fan-shaped; this lip is pure white, with a broad carmine blotch upon its expanded portion, and a smaller one on the narrower part. Like many other orchids, the flowers of this endure for a long time. This native plant is one which can be easily cultivated in an ordinary greenhouse, and while not so brilliant as many of its relatives, it cannot fail to be of great interest on account of its manner of growth. So far as we are aware, our native species of *Epidendrum*s have not been offered by florists,



A FLORIDA AIR-PLANT.—(*Epidendrum venosum*.)

on land that has been held by actual settlers for a hundred years or more past.

During more than a century, the coal-burners have every few years swept down the forests, from one end of the State to the other, so were

have to contend against, is the larva of *Dryocampa senatoria*. The moth deposits her eggs in large patches, on the under side of the leaf, which soon hatch, and the young larvæ move along in a vast colony, devouring the leaves as

they go. Toward the latter part of summer, trees are often entirely denuded of leaves, and the disgusting larvæ seem to be everywhere present, on the lawn, in the garden, on the sidewalk, until one shudders at the very thought of even a walk, to say nothing of a seat under the oaks.

Another enemy is the Oak-pruner. This fellow would not be so very objectionable if he did not prune too closely, and had sense enough to know where the pruning was needed, but like some senseless

horticulturist, he slashes right and left, without any regard to beauty or symmetry, and down come the twigs, and sometimes quite large branches. The workman always falls with the

it not for these exceptional trees, we should not know, except by tradition, how large the white oak and some other species would grow. But now, alas! when we just begin to appreciate and realize, how truly beautiful these various species of oaks are, when we are laying out parks, and leaving groups here and there to beautify our village, we find they are preyed upon by at least four enemies—two vital ones, the Gigantic Borer (*Prionus laticollis*),

and the locust borer (*Hylctus robinie*). The former is the larva of the largest beetle in the Northern States. Fig. 1 shows the larva, and fig. 2 the beetle, both of the natural size. This borer attacks all the oaks, but seems to prefer the white oak, making its winding paths through the wood of the trunks of the trees, weaken-

ing them to such an extent that large trees are frequently prostrated by a strong wind. The locust borer at present threatens to become even more destructive than *Prionus*; it is the larva of a large moth, (*Hylctus robinie*) and has proven very destructive to the locust groves in the Western States; but with us its preference is decidedly for the oak—the black oak (*Quercus folcata*), and the allied species are its favorite haunts. Fig. 3 gives the larva, and fig. 4 the female and fig. 5 the male moth. This morning, June 30th, I found seventeen empty chrysalid cases protruding from the trunk of one small tree. They seem to be much more numerous this season than in any previous year. But the most disagreeable of all the pests we

perfect insect comes out to lay eggs for another crop, which it deposits in the axils of the leaves.—ED.]

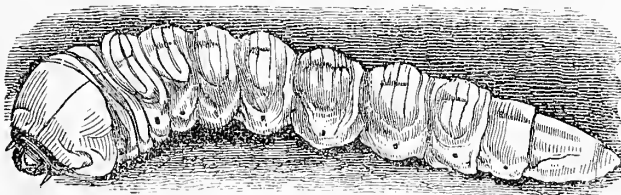

Fig. 1.—LARVA OF OAK-BORER.

but those who have friends who visit Florida in the winter, can readily procure them.

The Enemies of the Oak.

BY MRS. MARY TREAT.

The oaks of New Jersey seem to be doomed. "Small matter as to that," is the sneering retort. "Did New Jersey ever produce a sizable oak anyway?"—Well that depends upon what you call a sizable oak; it probably has never produced an oak quite equal in size to the gigantic Sequoias of California; but I have seen respectable oaks growing in New Jersey. In Atlantic County I have found larger

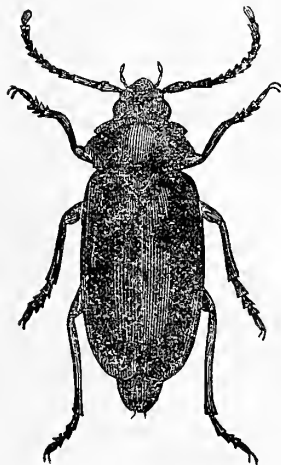

Fig. 2.—OAK-BORER BEETLE.

white oaks (*Quercus alba*), than in any Northern or Western State that I have visited. True, this is exceptional, and such oaks occur only

Fig. 3.—LARVA OF LOCUST MOTH.

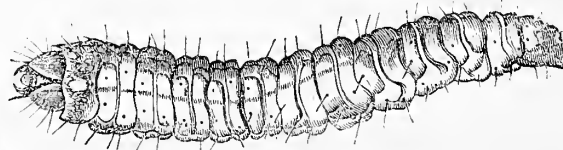

Fig. 3.—LARVA OF LOCUST MOTH.

Fig. 4.—FEMALE MOTH.

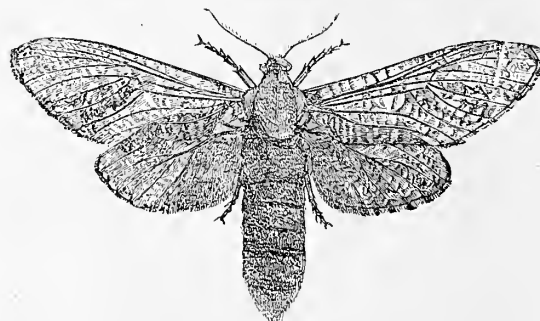

Fig. 4.—FEMALE MOTH.

seems he has sense enough to look out for himself and fall with the twig. Out of many hundred freshly fallen specimens, I have never failed to find the culprit safely ensconced in the twig. It is the larva of some beetle, but I have failed as yet, to rear it to the perfect insect. [This is probably the insect, a small slender beetle, described in Harris' Insects as *Stenocorus (Elaphidion) putator*; the means of preventing its increase is to gather and burn the prunings before the

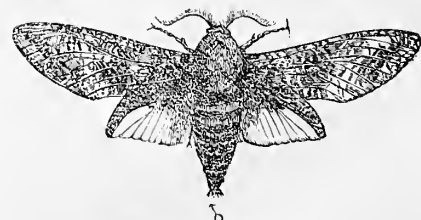

Fig. 5.—MALE MOTH.

perfect insect comes out to lay eggs for another crop, which it deposits in the axils of the leaves.—ED.]

Vineland, N. J.

THE HOUSEHOLD.

(For other Household Items, see "Basket" pages).

A Corn Knife.

In October 1872, we published a description with engravings, of a corn cutter sold at the furnishing stores, which was indented for cutting the kernels of green corn, and pressing out their contents at one operation. This cutter worked very well, but being made to sell at a very small price, was a cheaply made affair. "O. H. A." of Winchester, Va., sends us a drawing of a corn knife, which we have had engraved. Mr. A., says:

"It is used to cut green corn from the cob, the same as the corn cutter, figured in October

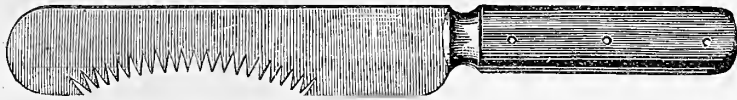

HOMÉ-MADE CORN-KNIFE.

Number, 1872, and can be made by any person having a handsaw-file, and an old table knife. Take an old table knife, or a new one will do equally well, and cut out circularly with a cold chisel $2\frac{1}{2}$ inches of the edge: then file sharp teeth altogether from one side, so that the points will present a long cutting surface. Pass this edge a few times down the ear, then scrape it with the back of the knife, and you have all the kernels of corn out, with the hull left on the cob. Corn prepared in this way is very much more digestible, then when cut or eaten from the cob.

Home Topics.

BY FAITH ROCHESTER.

"MAMMA, COME AND SEE."—I had just written "Home Topics" at the top of my page, when I heard the familiar call, "mamma, come and see my house! Mamma, come and see my house!"

"Mamma has gone up-stairs, and she can not come now," said Auntie. And so the call was hushed for a few minutes, Auntie having given a few words of praise to the little house-builder three years old.

How much of my time is spent in going "to see"—flowers, wild and "tame," toads, frogs, snakes, beetles, worms, insects' eggs and larvae, pictures, maps of imaginary lands, block-houses and churches, and barns and pig-stys, and monuments, supposed to belong to the inhabitants of those imaginary lands, and other things "too numerous to mention"?

Does it pay?—It interferes with the order and promptness of housework, it hinders the sewing, it interrupts my reading and writing—the very little that I undertake to do in these busy days. Often I am so tired that I dread to hear the call, "come and see," and it is a real self-denial (as far as "the flesh" is concerned) to give up a moment's rest for a child's gratification.

But "the spirit"—the enlightened mother-spirit—is always willing to sympathize with a child's pleasure, and to encourage its happy activity and investigation. There is so much occasion for reproof and disapprobation in our intercourse with growing children in whom nature has a chance to assert itself and cut up capers, that we ought to seize every opportunity to gratify their innocent desires, and to listen to their fresh experiences, though they may seem trivial to a superficial observer. Children's experiences and observations are not unimportant, and parents who judge of them by the usual standard of grown-up experience, make a very great blunder. They "snub" the artless inquirers again and again, and wonder at last that their older children do not confide in them more. Is it any wonder?

It seems very necessary that the children should have their little garments kept clean and whole, and that the rooms should be swept and garnished

with regularity, and it hurts a housekeeper's feelings to have anything interfere with good house-keeping. But a true woman, who is blessed with children, lives more in her mother nature than in the disposition of a housekeeper; and in looking back over a season, she considers with more pleasure the progress her children have made in their general education toward a useful manhood, or womanhood, than any feats in the line of soap-making, fruit-preserving, or sewing. But it is like the tithe-paying and deeds of love—"These ought ye to have done and not to have left the other undone."

PARENTAL INFALLIBILITY.—I suppose there is nothing more silly than the attempt to appear knowing upon subjects where we are really ignorant. We are, all so extremely ignorant; or we have, each of us, even the best informed, so little

knowledge compared with the great sum of attainable knowledge, that any pretension of "knowing everything" is very absurd. If children are encouraged to ask questions about what they observe, they will puzzle the mother of average education very frequently. She need not be at all afraid or ashamed to answer, "I don't know"; but she ought not to let the matter rest there. She ought to show an interest in the matter, and to find an answer to the question if she can. I have not found that children lose respect for their parents on account of their ignorance. I have to confess ignorance every day, and it is all taken to be natural enough. The thing which interested children wonder at most in grown-up people is their lack of interest in natural phenomena. Nothing hurts them more than the contempt of older people for their investigations—and it is very cruel. No doubt Agassiz was considered a lazy boy by some industrious people while he was floating about in his boat on lake Neuchatel, looking down into the water to observe the habits of the fishes. No doubt he was thought a cruel boy when he was seen dissecting insects and other animals. No doubt he was called a "girl-boy" when he came from the woods with his hands full of wild flowers for analysis. Yet the whole world knows him now as a kind-hearted man, and his life is remembered as one of great industry and usefulness. It is fortunate for us all that his natural bent was not interfered with. Our little inquirers may never become "great"—I don't care a fig for that—but they have a right to the use and development of such faculties as they have.

THE CORNER-CHAIR.—In one of the early numbers of HEARTH AND HOME there was an illustrated description of a large corner-chair, such as any

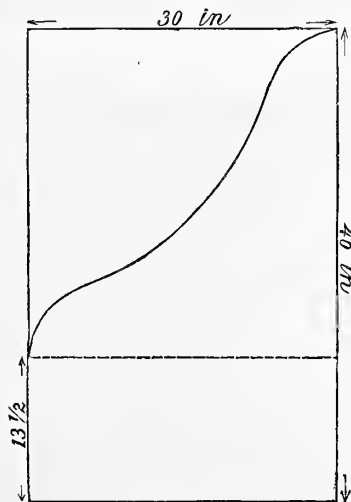

Fig. 1.—SIDE OF CORNER-CHAIR.

carpenter could make, and any woman of "faculty" might upholster. By the aid of the description and illustration we made ourselves such a chair, but found it too large to move out of the room. So it went with the house when the house was sold. I

write now from the corner where that chair stands, and the youngest member of our family, aged two months, lies sleeping in the chair, his favorite daytime couch. I like to use it for baby's bed (or one of his beds), because the high back affords a good chance to throw a mosquito-net over him, out of the reach of his hands.

The chair is on castors, and may be moved to any part of the room, but its appropriate place is a corner—either a light and sunny corner, or one near the fire in winter. Its ample dimensions and cushioned sides make it a cozy place for an after-dinner nap. Two or three small cushions piled up in the back would often be useful with the chair, as they could be arranged to suit different postures. The covering of the chair may be of any suitable material—calico, if you choose, or velvet, if that suits your taste and purse better. The bottom, or seat, of our chair pulls off and reveals a box of two compartments beneath, where things not often needed can be packed away. These compartments are papered neatly inside, and a short groove under the seat-board on one side enables one to get hold and pull off the cover.

I forgot whether our chair was made exactly according to the measurements given in HEARTH AND HOME, but its size and shape suits us very well. Two broad boards, 30 x 46 inches, are cut in the shape shown in figure 1. The seat of the chair is shaped as though a square board, 30 x 30, had

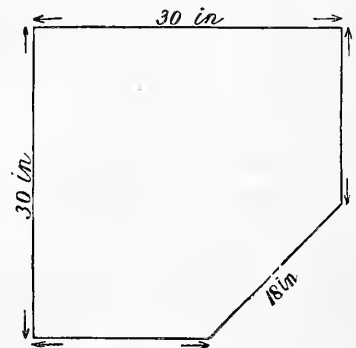

Fig. 2.—BOTTOM OF CHAIR.

one corner, or triangle with a hypothenuse of 13 inches, cut off. A frame is made in the same shape for this seat to rest upon, at a distance from the bottom of 13 inches. The seat-board raises the seat an inch higher, the castors another inch, and the cushion two or three inches more. Another board, 30 x 30, with one corner cut off, like the seat, forms the whole bottom of the chair. Cleats are nailed on at the place indicated by the dotted line in figure 1, and the three sides of the front of the chair are boarded up.

HOUSEHOLD EXERCISE.—To many women the labors of housekeeping are quite attractive, especially if the houses they keep are their own. There is some dirty drudgery about the business, necessarily, though I think this will be lessened as machinery and neighborly co-operation come more and more into use. Work is a lessening as well as a necessity to the human family, but affairs are so mixed up at present that some people have too much of it, and some have too little, for the good health of either class.

Miss Alcott cannot afford to let a hired girl do the ironing, it is such rest to her own arms and hands when weary with writing. I found, not long ago, when living in another home than my own, that I was much healthier for having a part of the housework to do, though my own housework—the care as well as the labor—had been too much for my health at the time. As strength came back, its moderate use was the best way to increase it. Women, who have brain-work to do, will find it a good plan to perform some light household exercise before entering upon the writing or study. An easy walk out of doors may be better, but if there is housework to be done, that had better come in the morning, and the out-door work later in the day.

Dish-washing is good for dyspeptics. It is light exercise of the arms and chest soon after a meal.

and it may be done sitting as well as standing. A high office-stool is very useful in the kitchen. Feeble women, who do their "own work," often stand upon their feet more than is necessary. You can sit down to dress vegetables, to wash and wipe dishes, to knead bread, to iron, and to do many other things. You may be a little more slow about the work, but you will get through it in better condition. Housekeepers would often like to take an out door walk, only their "feet are so tired!"

Dish-washing would not be half so disagreeable as it often is, if the dishes were lightly scraped free from crumbs, and neatly piled up for washing. There should be a large dish-pan and plenty of hot water, with which to fill up the pan gradually as its contents cool. I seldom use soap for washing dishes, but to the unskilled, or to those who use much butter and fat in their cooking, it seems a necessity.

Sweeping is good exercise, if the floors and carpets are not dusty. Ah! that "if"! Bed-making will serve as gymnastics, if the beds are kept clean and well aired.

And what of washing? I do not think highly of the old-fashioned wash-board exercise. It is hard for both lungs and back. With good washers and wringers, and strong arms for the lifting, it may be made passable as exercise, and it is always a pleasure to see soiled things growing clean once more.

A moderate amount of ironing is good for women in health, in cool weather. On hot days the ironing should be done in a cool room, if possible. The ironing-table may be on a shady porch, or in the dining-room.

I really wish that every fashionable woman had to iron all her own washed garments for one month. She would then understand better the full meaning of the word "achy," as used by Mrs. Whitney to describe the puffs and ruffles on summer suits, putting together in her estimate of the cost of her garments the labor on the sewing-machine, and the hard laundry work. There are few women who have not wished, when doing up fine linen plaited shirt bosoms, that men could know by experience how difficult and trying the work is, until one has become skilled by practice. But cooking is perhaps the most important department of housework, and its exercise is not heavy in quality, though to some it may be heavy in quantity. It seems to me more and more like a high art, or dignified occupation, worthy to be called a profession—far more useful and honorable than—the legal profession, for instance. I should not wonder if really good and scientific cooks could do more to preserve and to restore our health, than the doctors of medicine can. As with ironing—the hardest kind of cookery is the least necessary, or the ornamental part. We should study to make our cooking work as little heating as possible. For instance, bread may be baked in the oven instead of cooking it upon the griddle in the form of "pan-cakes," and in hot weather we can avoid those forms of food that require constant stirring while boiling. A Warrener or a Rumford apparatus for cooking by steam diminishes the unhealthfulness of the cook's business, by confining the odors of the articles in course of preparation for the table. I hear, too, that there are ovens with glass doors.

If the family cooking seems laborious, study how you can simplify it without making the food less nourishing, or less attractive.

There is a great deal of necessary work to be done in the world, in order that we may all be comfortably clothed, and fed and lodged. I should like to see what would be the result if the labor and strength spent upon unnecessary work, usually considered ornamental, should be given cheerfully to doing the necessary work of the world, as a preparation for the advent of real beauty and genuine adornment in all departments of our daily life.

Farmers' Tables.

BY WM. H. MAHER.

Of the thousand and one illusions of my childhood there was none so long-lived, or that I was so sorry to part with, as my ideal farmer. I owe the

poets a grudge to this day for my disappointment. Why should he always have been pictured as "the jolly old farmer," "the most independent man in the world," "living on the fat of the land," and so on? I supposed that being a farmer, and being happy, were synonymous terms. And, as I have struggled with boarding-house beef, half wilted vegetables, strong butter, and watery-milk, I have sighed that my lot was not cast with those blessed sons of the soil—the farmers.

Day after day, poring over journal, cash-book, and ledger, I have drawn pictures of what my life might be when I could lay business aside and be a farmer myself. I was interested in the price of crops, although the only crop I raised was my monthly balance-sheet; and I took an interest in stock, although I was but the owner of a very scrawny-looking dray-horse.

But there came a time when my business could be laid aside, and I at once started out among the people I had envied so many years. Of course you all know how soon the charm was dispelled. The farmer might be independent, but he was very slovenly; he might be exceedingly "jolly," but his wife was dying of overwork; the only part of my early impressions that I found to be true, was that one which told of his living on the fat of the land. He did; on the fat and on but little else.

I had pictured the pleasantness of being among the soft-eyed cows; the graceful, innocent-looking sheep and lambs; the gobblers and other poultry; and there was even a pleasant note—in the distance and in imagination—to be found in the porcine-grunt. But I found the farmer pounding his cows with his milking-stool, kicking his sheep as they passed through the bars, beating his pigs with the most convenient stake, and throwing rocks at the hens and turkeys, as he cursed them in language as coarse as uncalled for.

But if there was aught of the charm still left in my mind, it was dispelled when I sat down to the family meal. Shades of departed dreams, what an awakening! Where were the juicy roast, the tender steak, the fine potatoes, with feelings too big for their jackets, the crimson beet, the sugary parsnip, the golden butter, and the "Adam's ale?" Even echoes fail to answer the question. They were probably on the table of the city boarding-house; they were not here.

The etiquette of the dining-room—of their dining-room—was an etiquette peculiarly their own. Preparation for dinner consisted of a hasty wash in the tin basin, and an equally hasty brush of the hair. The men in shirt sleeves, the "women-folks" with faces red from the stove, sat down at the table, which, to make less work, was placed in the warm kitchen where the dinner had been cooked. The "hearty hospitality" of which I had so often read, consisted in an order from the head of the house, to help myself, as they didn't stand on ceremony there.

But the bill of fare! Forgive them, Professor Blot, they knew no better! It consisted of fried ham, fried potatoes, and fried turnips; bread without butter, and very strong coffee. These were put away without much ado, and then, what was evidently the crowning pride of the house-wife, an immense pie was attacked, and demolished.

There was but very little conversation during the meal, and each one helped himself, if he could stretch far enough, and reach what he wanted.

Supper should be the daintiest meal of the day, and a farmer's supper more tempting than any other man's; but my friend's table was decidedly prosaic and plain; the ham had been warmed up so that it could swim in fat; the bread, cold potatoes, and pie and cake with tea completed the bill.

After supper the family was too tired to sit up long, and I was shown at a very early hour to the "spare" chamber, where I might repose on an immense feather-bed. If I tossed and tossed about that bed all night, the fault must have been in me. Was it not their best bed? and did they not use things all the plainer on their own, that this one might be as good as their neighbors' best?

An early call to breakfast, found me with a

splendid appetite. I could have appreciated a broiled steak, but I probably was over particular, and it served me right, to have to sit down to "the plain food of the farmer." Again the everlasting frying-pan had been brought into use, and instead of a juicy steak, it was fried hard and white. The potatoes almost floated in the grease they had been fried in, and those who wanted butter on their bread might dip in the gravy, as some of my companions did. There was thick black coffee, and the perpetual pie.

Such was the bill of fare for the three meals, and they were fair samples of our board during the month that followed. What was most noticeable to me was the entire, or almost entire, lack of vegetables on the table at every meal. Of course I did not mention the subject so that they would connect it with their own table, but I was curious to learn why it was they ate no vegetables but potatoes and turnips. The answer was they didn't like vegetables; they would as soon eat a pill as a pea; would rather have chopped leather than string-beans; and thought carrots and parsnips were only fit for cattle! When the subject of cooking came up, I noticed they prided themselves first, last, and always, on their cakes and pies.

Where, O, where were my visions now! Dead, dead beyond hope of resurrection. And now I find that these farmers whom I have mentioned are really typical of their calling. The great State of Massachusetts, through her Board of Health, has been looking a little after the farmers of that State, and publishes the result in the last Annual Report of the Board. Among the many questions of the Board to their correspondents, were questions as to the farmer's diet. The result of the questions prove:—

1. Good bread is scarce.
2. There is too little variety in food.
3. Meat is too apt to be fried.
4. Baked beans and salt pork too generally used.
5. Pastry and cakes are used to an injurious extent.
6. Too little time is allotted for meals.
7. Coffee and tea are too freely used.
8. Water is used to excess.

After quoting from the replies of correspondents, the author of the article in question says: "The suggestions of our correspondents are admirable and worthy of heed. The general opinion is: more fresh and less salt meat; less frying and more boiling, broiling and roasting; a greater variety of vegetables and fruits; less pies and cakes; more well-kneaded bread, raised with yeast; less tea.

"It is a somewhat singular fact that farmers live so little upon their own productions. They send their fresh vegetables, fruits, eggs, and poultry, to market, and live themselves upon salt-pork, pies, and saleratus.

"The poor cooking which prevails among our farmers, as well as all other classes, doubtless results from hurry; frying takes but little time and trouble, saleratus bread can be made in a 'jiffy,' and bread and pastry are heavy and sodden, because kneading requires time. The overwork of farmers' wives is therefore, in great part, responsible for inferiority of farmers' diet."

Alas! and again alas! that my fancies should have been thus rudely killed; and yet—it may be that the dream dies slowly—I can't help thinking that the fault is with the men and women who do not improve their opportunities, and not in the calling itself. I can not help thinking that their life ought to be just what it is not. Perhaps, after all, the poets wrote of *what might be*, hoping their prophecies would become realities. Would that the time was here.

[That the above is a truthful account of the way in which some farmers live no one can deny, but in justice to the many excellent housekeepers who are farmers' wives, and not only read, but contribute to these columns, we must say that the strictures of our correspondent are too general. Still, we let him "say his say," in the hope that it may contribute to a reform, for which, we regret to admit, there is still abundant room.—ED.]

BOYS & GIRLS' COLUMNS.

Water Melon-choly Accident.—

Yes, we repeat it, what a melancholy accident is represented in this engraving! Jack and Gill went up the hill, to get a watermelon, Gill brought her's back, but Jack's alack, his little toes it fell on. It is a proverb that "you can not carry two pumpkins under one arm." We never saw any one try it, hut can imagine it a hard task, and it is nearly as difficult to carry one watermelon in two arms, particularly if, as in the picture, those arms happen to be those of a little boy. Indeed, was there ever a more awkward thing to carry than a watermelon? Nature has furnished it with a handle, or stem, all out of proportion to its size, and if the stem chances to be strong enough to hold it, the weight of the melon makes it cut one's



BRINGING HOME THE WATER-MELONS.

fingers. But we must not find fault with the way melons are made, for they are made just right, and the fault is in our not knowing how to handle them. Besides, do we not recollect the fable in which the man found fault that the strong oak here only little acorns, while the heavy pumpkin had a little weak vine, and don't we recollect how an acorn, coming plump upon his bald pate, convinced him that the arrangement was just right, or, as the last line of the fable reads: "For had this tree but pumpkins borne, where would have been thy head?" Very likely Miss Gill will share her melon with her brother, and the next time they go to the melon-patch, they will take a basket along. A great many water-melons from the Southern States are sold in New York streets long before those grown near the city have ripened. These dealers fix a sort of sling of strong twine, so as to make a handle, by which the buyers can carry the unbandy things. There is a hint for boys.

Aunt Sue's Puzzle-Box.

CHARADE.

My first will designate a branch,
Seldom in civil parlance named,
Which, if composed of fibers staunch,
In troublous times will ne'er be shamed.

My next a village in the West,
And 'tis—but no, I can not feign,
Either that this one is the best,
Or yet the "loveliest of the plain."

Long years ago my whole was formed,
For foreign depredation meant,
But when by Nature's powers stormed,
Soon was it into fragments rent. HENRY.

SQUARE WORD.

1. A distinguished general, who, in a council of war, wrote on a card for each of his under-generals: "Advance in solid column, early in the morning." 2. One of Shakespeare's characters. 3. A boy's name. 4. Homes without hearths. 5. To scorch. LITTLE FOLKS.

CROSS-WORD.

My first is in paper but not in ink,
My next is in flower but not in pink,
My third is in whisper but not in talk,
My fourth is in ride but not in walk,
My fifth is in east but not in south,
My sixth is in ears but not in mouth,
My whole is an article dangerous quite,
And when touched with fire it will take its flight
In a column of smoke that is nearly white.

CAPTAIN FUNNYMAN.

DIAMOND PUZZLE.

1. Part of the face.
 2. An article of furniture.
 3. A division.
 4. Sad.
 5. A desirable trait in well-doing.
 6. Seen on the sea-shore.
 7. An article of furniture.
 8. A unit.
 9. Part of the eye.
- The center letters perpendicular and horizontal name a quality. GILES FARNIM.

PI.

Fi ony dowlu eb tenpung eb fiber; sword ear kilc samebuns, het rome hety rea cennosed eth peered tyeh nrrb.

GEOGRAPHICAL ANAGRAMS.

- | | |
|-----------------------|-----------------|
| 1. Mr. got money. | 5. Recent sham. |
| 2. L. dig level mile. | 6. Plover oil. |
| 3. Boil 'm. | 7. Mabel Earl. |
| 4. In stew pot. | 8. Shuu Dora. |

CONCEALED SQUARE WORD.

1. Which are the best arms, swords, guns, or pistols?
2. I asked him to read it, but he would not.
3. The sooner we are out of harm's way, the better.
4. Get as many more stones as you can carry, Jack. NIP.

NUMERICAL ENIGMA.

I am composed of 26 letters:
My 12, 15, 24, 19, 5, is a peak in the Rocky Mountains.
My 22, 14, 2, 19, 20, is a river west of the Mississippi.
My 25, 8, 22, 9, is a city in New York.
My 10, 22, 24, 25, 19, 22, 10, 20, 16, 26, is a capital.
My 2, 23, 5, 25, 4, 18, is a capital.
My 10, 2, 21, 15, 18, is a city in Georgia.
My 10, 2, 4, 18, 20, is the name of a State.
My 2, 25, 3, 17, 18, 25, 17, is the name of a capital.
My 17, 3, 6, 17, 18, 9, is the name of a capital.
My 1, 25, 13, 15, 7, 11, 14, is the name of a large West-ern city.
My whole tells where this enigma was made.
MINNIE, HESTER, AND ETTIE.

ANSWERS TO PUZZLES IN THE JULY NUMBER.

ANAGRAMS.—1. Individual. 2. Mutilated. 3. Hemorrhage. 4. Phosphorescent. 5. Momentarily. 6. Deceitful. 7. Overloaded. 8. Precipitates. 9. Imperfect. 10. Inclined.

CONCEALED SQUARE WORD.—B A N D

A L O E
N O T E
D E E D

PI.—One gentle word that I may speak,
One kind and loving deed,
May—though a trifle poor and weak—
Prove like a tiny seed;
And who can tell what good may spring
From such a very little thing.

NUMERICAL ENIGMA.—Monongahela.

CROSS-WORD.—Franklin.

DIAMOND PUZZLE.—

D
G I G
B R A N D
D I A M O N D
C R O U P
A N N
D

PATCHWORK.—An-ag-r-am—anagram.

CHARADE.—Pippin.

AUNT SUE'S NOTICES TO CORRESPONDENTS.

Mrs. LIZZIE M.—Your riddles are very acceptable. Thanks.

TILLIE S. D.—Don't scold: the "Sphinx" of the Graphic Hearst and Home is not at present under my charge, so I am not "responsible."

Thanks for puzzles, letters, etc., to Chas. A. Sproach, F. Vondersmith, Billy Button, E. L. K., N. R. F., jr., Muggins, and Ellie Van B.

The Little Garden.

Last May, I think it was, I had something to say about sowing seeds in your little gardens. There are many plants, which grow much better by dividing the old ones, and planting the pieces of root. And now is the time to be looking out for these, so that when fall comes, and the leaves die down, you will know where to get these roots. It is a good thing, that those who love flowers, also like to have others enjoy them, and they will rarely refuse a bit of a root to another, especially to a child. But all of you who live in the country can easily get plants for your little gardens without troubling others.

The woods and the meadows have many beautiful flowers quite as handsome and interesting as those from other countries, only we don't think so because they are wild and "so common." That is just the way people think of our choice garden flowers in the countries they come from. Sunlight is "very common," but not the less glorious, and so it is with our wild flowers. If you get our wild Columbine from the rocky hill-sides and plant it in good garden soil, it will grow much finer and bloom longer than you ever saw it when growing wild, and if there are any of the garden Columbines near by it will excel them by its grace and beauty. So with the Bluets, the Anemones, the Violets, and a long list of wildlings; if you take them up with a good bit of earth about their roots, and shade them for a few days, the most of them will grow right on as if nothing had happened, even if taken up while in bloom. I say "the most of them," as there are some plants that don't like to be moved, no matter how carefully you do it, but you will only find out which these are by trying. The flowers just mentioned come in spring, and are small. The large late ones had better be marked with a stick, so that you can find the roots when they have done blooming. Many of the Asters, the Cardinal flower, the wild Lilies, the Butterfly-weed, and a long list of late wild flowers, will make a fine show in the bed. This growing of wild flowers in the garden is very interesting; I know, for I have done it for several years, and am quite as fond of my little natives as I am of the more costly ones that come from far-off countries, and have very grand but not very pretty names. Now I hope you all will see that there is no difficulty in the way of any boy or girl who is old enough who wishes to have a garden. Then how fine it will be if the boys and girls of the same family will only work together in it. As I go about the country there is nothing that I see that interests me more than here and there a little corner where some boy or girl has a few flowers. Bless their little hearts, they will get them so full of the love of the most beautiful of God's works that wicked thoughts will find no room.

THE DOCTOR.

Aunt Sue Goes to the Hippodrome.

I promised in last month's Chats to tell you more about Barnum's Hippodrome. Many of my friends went there, and the question was often asked me, "Aunt Sue, have you been to the Hippodrome yet?" "No, I have not." "Oh, you must, it's splendid!" At the risk of falling in the esteem of many of my friends, I must admit that I always did like to go to the circus, and it was not at all unpleasant to be urged to go. I sent in advance and procured two reserved seats, (those who are curious about my personal appearance, need not form an estimate of my dimensions from the foregoing statement, as I intended to go with a lady friend.) It was a very warm day when we found ourselves at Madison Avenue, going into Barnum's, and Oh! how cool and pleasant it was inside. The animals, glass-blowers, candy counters, soda water, lightning calculator, curiosities, portraits of distinguished individuals, etc., etc., are at the back, and under the steps or seats, that surround the arena walked in. I tried to see everything at once, but having only one pair of eyes, I was not successful, so I concluded to go to work systematically. First stall to the right, two giraffes, looking just as they do in the picture-books, only more so, light fawn color, two of them, one eating out of a rack as high as your ceiling, the other sticking his funny little nose through the bars at me; I wished I had a bit of pie for him; "don't eat pie?" Well then an apple or a banana, or something he did like, he had such large beautiful soft eyes. But I mustn't stop here, making love to this giraffe, or I shall not get my money's worth of sight seeing. Next, a funny little black bear, kangaroos, leopards, tigers, four-horned goat, zebra, llamas, guu, guanaco, rhinoceros; I did not stop long to look at these, for a little further on I saw between ten and twenty ponies, from the size of a dog up to a calf, in a stall, with their dear little heads close to the passers by; such saucy little fellows; of course I had to speak to each one, when they stretched their necks so far over the dash-board (?) to greet me. I do love horses, and these were so get-at-able that one couldn't help petting them. One little chap laid his ears back, so I skipped him. Then the elephants. I have always thought I should like to cultivate the affections of an elephant; they are so sensible, so faithful, I should no more insult an elephant, by offering him a stone instead of a peanut, than I would hurt a baby. One of the largest was leaning too far over the stall, trying to reach friendship's offering, when the keeper, going by, said, "go in, Betsey!" and passed on. Betsey turned her trunk towards him, and investigated the back of his vest, until he had got beyond her reach, in a sort of "who are you! and what do you know about it? I shall do as I've a mind to" manner that was very funny. Old Carlo was walking about, in among their feet. Betsey is very

fond of this celebrated dog, and frets after him if he goes away. Carlo is fifteen years old, and can't live much longer, and the elephants' keepers are dreading the effect upon Betsey, when poor old Carlo dies. The polar bears looked a little over done with the heat in their fur robes, but they were refreshed occasionally with ice water. The two immense sea-lions had a grand tank to

Then came France, next Rome, then Turkey, Italy, Egypt, Russia, (the band playing the national air of each, when they first entered), Ireland, Spain, China, India, (camels and elephants had their place in the procession), America, and last and least "Lilliput," lots of little children dressed as knights and soldiers, on my little pets, the ponies, with any number of infantry. It was a

ungracefully, that it looked for all the world like a great goose on four legs.

The exhibition wound up with "20 minutes of fun, or the Lancashire Races." In one minute they had raised booths around the arena. Crowds came to the Fair, four funny fellows danced on a platform; the band played; bells rang; the hand-organ man was there; boys raced in sacks, (tumbled down and couldn't get up); with wheelbarrows; on donkeys; climbed a greased pole: and had just the jolliest time that ever was. One grand race of all the Lancashire lasses on horseback, closed the performance. I need not say that we enjoyed our visit to the Hippodrome.

Something About Dogs.

Who likes a dog? "I," "and I."—Oh yes, of course, you all do. It seems to be a part of boy nature to like dogs. Yes and girl nature too, for the girls are quite as fond of them as the boys, though perhaps they like rather quieter dogs than the boys do. Notwithstanding there are some unpleasant things about dogs, we suppose they will always be kept as domestic animals, and that as long as there are boys and girls, each will like his or her own pet, and think it the best dog that ever lived. A stupid dog is a very uninteresting thing, but there are many dogs that are very far from stupid. They show so much intelligence, that we do not wonder that boys and girls become fond of them. Many and many are the stories that have been told of the intelligence of dogs, and some of them do things, which almost make us think that they know more than some stupid people. Reading in an English journal, the "Science Gossip," not long ago, we came across the following, which was given as something very wonderful for a dog to do. A clergyman says:

"A gentleman residing in my parish possesses a fine animal, which he is accustomed to send daily to the railway station for his newspapers, the distance being about a quarter of a mile. As soon as the train has arrived, the dog takes the shortest cut across the field to the station, and looks at the station-master in a knowing manner, clearly announcing the object of his errand. The railway official duly delivers the paper to the canine messenger, who forthwith takes it in his mouth, and trots back again to his master's house, with a degree of importance which shows that he is fully alive to the trust committed to his charge."

Now this did not seem to us as anything so very strange, and we have no doubt that many of our boys girls have seen dogs do quite as smart a thing as this. And we thought we would ask if it were not so. If any of you can tell us any good dog stories, that is those which show intelligence in the animals, we would like to have them, and if we think they are good enough, we shall be glad to print them.—Who speaks?

The Little Gleaners.

In this country we know little about gleaners and gleanings. In olden times the scattered ears of grain were considered the right of the poor, who went after the reapers and harvesters, and gathered them up for their own use. A very old custom indeed, for in the Mosaic law it was forbidden to reap the corners of the field, and to gather the gleanings of the harvest, as these were for the poor and the stranger. This Scripture custom was kept up within recent times, and the poor laborers in Europe regarded it as their right that their wives and children should pick up the scattered grain. The privilege was often abused, the gleaners not only taking the fallen grain, but often pulling out that which was in the sheaves, and the custom is now but little observed. Indeed, with the reaping by machinery, there is but little left for the gleaners, and they would not find much to gather upon the modern wheat-field. The little ones in the picture have no doubt heard of gleaners, and may have read in the Bible about Ruth, who "came and gleaned in the field after the reapers," and they are following the old custom just for fun. It may be that they are gleaning for their pet chickens, or for their rabbits, but whatever they are doing it for, they, with their bright faces and pleasant laughter, make the field much pleasanter than it would be without them. It is not well to forget about these customs almost as old as the race, even if we have found out other and quicker ways.



THE LITTLE GLEANERS.—Drawn and Engraved for the American Agriculturist.

swim in; what extraordinary things they are to look at. The Bengal tiger was a magnificent animal. The young men who had the animals in charge, were all kind and polite, ready to answer any question to the best of their ability. I asked the keeper of the tiger, if the animal knew him, if it ever showed any affection; he didn't think it cared for him more than any one else, although it always purred like a cat when he fed it. Can you fancy a tiger purring? We would fain to have looked longer at the funny monkeys, at the pretty birds, at the camels, at the glass-blowers making such graceful pretty things, etc. But it was nearly time for the performances, so we went up the stairs leading to the main building, and were shown to our seats. A very fine band, in gorgeous regimentals, furnished sweet music. The signal was given, the drums were beaten and the grand procession, "The Great Congress of Nations," began its march. First Great Britain was represented; "Queen Victoria," clad in purple and gold, on a splendid car drawn by four horses. Earls, heralds, horse guards, yeomen, dukes, marquises, and princes, mounted, and on foot, with their appropriate flags, in attendance. The band played "Rule Britannia," as the royal cortège passed.

gorgeous procession, filling the entire circle and two rows down the centre. That alone was worth the price of admission. But after that came the athlete who walked through rings, (catching his feet in one ring after another), with his head hanging down! A net was stretched under him to catch him if he fell, but I always look at such exhibitions with my eyes shut. The same with Miss "Victoria," when she rode her velocipede, from one end of the Hippodrome to the other, on the "lofty wire." Then came races on horses, races in chariots, monkey races on ponies, "twenty-one horses at liberty," (no riders); they were led up to the judge's stand, and at a signal they were allowed to start. Oh! how they went, like the wind! "Now the black is ahead! The sorrel has passed him, black shoots ahead, neck and neck with grey, wonder if they look like that, when racing wild over the plains! Black is ahead again! How will they ever stop these creatures? The judge taps his bell, black has won the race; the attendants raise a canvas across the track, and the wild arab steeds dart under the curtain out of sight. The camel race was very comical. I had never seen a camel run before, and the creature stuck out its long neck, and tumbled along so

Life Insurance.

All governments have specially recognized the usefulness of life insurance by making laws for its wise direction, watching over it, encouraging and fostering it, because of the benefits it bestows upon all communities. In fact it is the duty of all public authorities, among whom the press is one of the most powerful, to see to it that the system of life insurance shall be made as nearly perfect as possible, and that so long as it affords to the most helpless members of a community absolute security against those terrors of poverty which succeed the death of their natural protectors, it shall be rigidly upheld in public estimation.

Since their organization seventy-one of the leading life insurance companies of the United States have had 47,253 claims presented to them, covering \$139,376,577.08 of insurance, of which 46,935, equaling \$137,625,376.76 insurance, or over ninety-eight and three-fourths per cent. of all claims made, have been paid on demand without litigation or contest of any kind; that 83 claims, covering \$380,677.17 in amount, have been paid after litigation upon the verdict of a jury or by compromise, and 110 claims, covering \$513,232.15 of insurance, successfully resisted, leaving 190 claims, covering \$857,292 yet unsettled.

The history of these seventy-one companies—and they embrace nearly the whole of the life insurance companies in the country—is the history of life underwriting in the United States, and it proves that over ninety-eight per cent. of every claim made has been promptly paid on demand, and less than two per cent. contested in any way. Among these companies is the United States Life Insurance Company. It is one of the strongest as well as most honorable of our life companies. It has never contested an honest claim, and has made thousands of widows' hearts sing for joy because of its timely benefactions. It is a company whose foundations are as solid and whose record is as clear as its renown is wide.

YOUNG MEN.

BOYS & MIDDLE-AGED MEN
Trained for a Successful Start in Business Life, taught how to get a Living, Make Money, and become Enterprising, Useful Citizens. EASTMAN BUSINESS COLLEGE, FOUHKEEPSIE, N. Y. On the Hudson, the only institution devoted to this specialty. The oldest and only practical Commercial School, and only one providing situations for Graduates. Refers to Patrons and Graduates in nearly every city and town. Applicants enter any day. Address for particulars and Catalogue of 3,000 graduates in business.
H. G. EASTMAN, LL.D., Foughkeepsie, N. Y.

WILL WIND ANY WATCH And Not Wear Out.
For sale by Watchmakers. By mail, 50 cents.
J. S. BIRCH, 37 Maiden Lane, New York.

Money — Brains — Knowledge.
Learn how to make money and gain knowledge near home, by selling "GOOD BOOKS FOR ALL." Send stamp for particulars to S. R. WELLS, 389 Broadway, New York.

"The Verdict."
GOOD CABLE SCREW WIRE
Boots and Shoes
BETTER THAN PEGGED or SEWED.

MONEY MADE RAPIDLY with Stencil and Key Check Outfits. Catalogues and full particulars free: S. M. Spencer, 117 Hanover St., Boston, Mass.

(CIRCULAR.)

Consumers' Importing Tea Co.,
No. 8 Church Street,
P. O. Box 5,509. New York City.

This is a combination of capitalists to supply the consumers of Teas throughout the United States on the mutual principle.

We have experienced agents in all the best districts of China and Japan to select Teas especially for our trade.

We expect every consumer of Teas to render us all the assistance they can in carrying out our enterprise, as we make a specialty of SUPPLYING CONSUMERS ONLY (and allow no middlemen to make any profit on our importations), which will enable us to supply them with Teas at prices lower than have ever been known, and of those fine qualities that seldom reach the interior, being sold only in the large cities and among the very wealthy.

Hoping the consumer will take an interest in our enterprise, and send at once for a circular with full explanations of how to proceed to obtain our goods, we remain,

Most respectfully yours,

Consumers' Importing Tea Co.,
No. 8 Church Street,
P. O. Box 5,509. New York City.

Entered, according to Act of Congress, in January, 1874, by the Consumers' Importing Tea Co., in the Office of the Librarian of Congress, Washington, D. C.

GEO. A. PRINCE & CO.
ORGANS & MELODEONS.

The Oldest, Largest and Most Perfect Manufactory in the United States.

54,000

Now in use.

No other Musical Instrument ever obtained the same popularity.

Send for Price-Lists.
Address **BUFFALO, N. Y.**

Parents, reduce your SHOE Bills two-thirds, by buying **SILVER-TIPPED SHOES.**

S. B. Parsons & Sons offer at Flushing, N. Y., Camellias, Azaleas, Roses, and Rhododendrons, and other Trees and Plants.



Rifles, Shot Guns, Revolvers, Pistols, Ammunition, Fishing Tackle, etc. For Price-list, see page 157, April No. Am. Agriculturist, or address, with stamp, **GREAT WESTERN GUN WORKS,** 285 Liberty St., Pittsburgh, Pa.

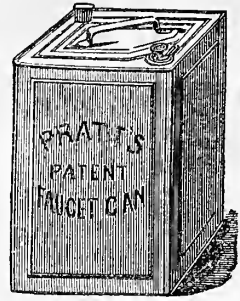

PRATT'S ASTRAL OIL
ABSOLUTELY SAFE PERFECTLY ODORLESS.
ALWAYS UNIFORM, ILLUMINATING QUALITIES
SUPERIOR TO GAS
BURNS IN ANY LAMP WITHOUT DANGER
OF EXPLODING OR TAKING FIRE
MANUFACTURED EXPRESSLY TO DISPLACE THE USE OF
HIGHLY VOLATILE AND DANGEROUS OILS.

ITS SAFETY UNDER EVERY POSSIBLE TEST
AND ITS PERFECT BURNING QUALITIES
ARE PROVED BY ITS CONTINUED USE IN OVER
500,000 FAMILIES,
WHILE NO ACCIDENT DIRECTLY OR INDIRECTLY
HAS EVER OCCURED FROM BURNING,
STORING OR HANDLING IT.

THE MANY IMITATIONS & COUNTERFEITS
OF THE
ASTRAL OIL THAT HAVE BEEN THROWN
UNSUCCESSFULLY ON THE MARKET IS FURTHER PROOF
OF ITS SUPERIOR MERIT
THE ASTRAL HAS NOW
A WORLD WIDE REPUTATION
AS THE SAFEST AND BEST.

THE
INSURANCE COMPANIES AND FIRE COMMISSIONERS
THROUGHOUT THE COUNTRY
RECOMMEND PRATT'S ASTRAL OIL
AS THE BEST SAFEGUARD WHEN LAMPS ARE USED
CHS. PRATT & CO.
ESTABLISHED 1770.
108 FULTON ST. NEW YORK.

Self-Propel-For Cripples

Can be easily in or out doors, ing the use of State your weight for illustrated ferent styles and

Please mention this paper.



ling Chairs and Invalids propelled, either by any one hand- and send stamp catalogue of dif- prices.
S. A. SMITH,
No. 32 Platt St., N. Y. City.

PLUM TREES.

50,000 splendid two-year trees — cannot be surpassed, if equaled, by anything in this country.

CHERRIES AND PEACHES.

A large stock, including all the new varieties. Also, a general Nursery Stock, very fine. Send for Price List. **NICHOLAS & NEWSON,** Geneva, N. Y.

Highest Premium (Medal) Awarded by AMERICAN INSTITUTE.



ASBESTOS PAINTS, ROOF COATING, CEMENTS, BOILER FELTING, SHEATHING, and GENERAL MATERIALS FOR ROOFING, STRUCTURAL AND OTHER PURPOSES. These materials are prepared ready for use, can be easily applied by any one, and are put up for shipment to all parts of the world. LIBERAL INDUCEMENTS TO GENERAL MERCHANTS AND DEALERS. Send for descriptive Pamphlets, Price Lists, etc.

Patentee and Sole Manufacturer, } **H. W. JOHNS, 87 Maiden Lane, N. Y.**
ESTABLISHED 1859.

DUTCH BULBOUS ROOTS AND SMALL FRUITS.

Our Autumn Catalogue of the above, beautifully illustrated with many engravings and a splendidly colored lithograph of a Group of Double and Single Hyacinths, will be ready for distribution Sept. 1st. A copy will be mailed to all applicants inclosing Ten Cents; regular customers supplied gratis. Address

B. K. BLISS & SONS,
SEED, PLANT, & BULB WAREHOUSE,
34 Barclay St., New York.
P. O. Box No. 5712.

VICK'S CATALOGUE of Hyacinths, Tulips, Lilies, and all



Now published for Autumn of 1874, and will be sent free to all who apply. 32 pages—50 illustrations. Address, **JAMES VICK, Rochester, N. Y.**

HYACINTHS, TULIPS, CROCUS, LILIES,

and all other Bulbs for planting in the Autumn; also Bulb-Glasses, Fancy Flower-Pots, Fern-Cases, Winter-Flowering Plants. The largest and finest assortment in the country. Prices moderate. Descriptive Catalogue mailed to all applicants free.

HENRY A. DREER,
714 Chestnut St. Philadelphia, Pa.

New Early Peaches, Dutch Bulbs, New and Rare Plants.

Rivers' New Early Peaches, Early Beatrice, Early Louise, and Early Rivers'. The earliest Peaches known, with a collection of other new varieties of Peach raised by Mr. T. Rivers—a fine Stock.

Beurre d'Assumption, Souvenirs du Congress, and other new Pears.

Dutch Bulbs—Hyacinths, Tulips, Lilies, Narcissus, &c. New and Rare Plants—Plants for Winter-flowering, &c. Catalogues mailed on application.

JOHN SAUL, Washington City, D. C.

Plants for Winter Flowering! Plants for Florists' Stock.

We offer **Winter-blooming Carnations** (fine) for 20 cts. each; \$15.00 per 100—ready in Sept. **Tuberose**s, started in pots for winter-bloom, now ready at same price. **Chinese Primroses**, (dbl. white, \$5.00 per doz.; Single, \$3.00 per doz. **Smilax**, large roots, 20 cts. each; \$2.00 per doz. Seedlings ready in Oct. and Nov., at \$1.00 per 100. **Violets**, Dbl. Blue and Marie Louise, \$8.00 per 100. **Begonias**, Winter-blooming, extra large, 25 cts. each; \$2.00 per doz.; small plants, \$5.00 per 100. **Callas**, extra large, \$3.00 per doz.; young plants in Dec., \$3.00 per 100. **Bonvardia Davidsonii**, fine, 4 in. pots, 25 cts. each; \$2.00 per doz. **Cyclamen Persicum**, a few 5-year bulbs, at \$1.00 each; general stock, 25 to 30 cts. each; \$15.00 per 100. **Dwarf Pomegranates**, 15 cts. each; \$10.00 per 100. **Roses**, tender sorts, grown in pots for winter-blooming, extras, 50 cts. each; 3 to 4 inches, 25 cts. each; \$2.50 per doz. Also our usual supply of young plants for mailing, at \$ for \$1.00. **Early White Roman Hyacinths**, the earliest and best for forcing, 20 cts. each; \$1.50 per doz.; \$14.00 per 100. Also a large stock of extra size plants of **Zonal Geraniums**, **Fuchsias**, &c., for Florists' stock. Our stock is large, and we are bound to sell. General Price List out in Sept. Good judges say we grow the finest Tuberose bulbs in America.

MASSEY & HUDSON,
Chestertown, Kent Co., Maryland.
P.S.—Being about to abandon the vegetable seed-growing department, and devote our entire attention to Flowers, we offer for sale about 400 hot-bed sashes, 3½x7 feet, at \$2.50 each, delivered in Baltimore.

GRAPE-VINES.

LARGEST STOCK IN AMERICA. Extra quality. Reduced Prices. **T. S. HUBBARD,** Fredonia, N. Y.

Currants, Gooseberries, Herstine Raspberries, Grape Vines, and Shrubbery, very low. **WM. H. MOON,** Morrisville, Pa.

DUTCH BULBOUS ROOTS.

J. M. THORBURN & CO.,
15 John St., New York, announce the largest and most varied Importation of Dutch Bulbs ever received in this market. Catalogues on application.

Surplus Stock.

PEACH—1 year, fine, \$20 to \$60 per M.
CHERRY—2 year, fine, \$80 to \$150 per M.

An immense Stock for Nurserymen and Dealers—at lowest rates. See our

Surplus Stock List.
THE DINGEE & CONARD CO.,
Wholesale Nurserymen,
West Grove, Chester Co., Pa.

- Trees,** 500,000 Apple, Pear, etc.
- 100,000 Peach Trees.
- 100,000 Grape Vines.
- 50,000 Currant Bushes.
- 500,000 Sweet Chestnut Trees.
- 10,000 Spanish " " " " " "
- A CHESTNUT CIRCULAR FREE.
- 1,000,000 Evergreens, best in market.
- 200,000 Deciduous Trees and Shrubs.
- 50,000 Magnolia Acuminati, one year, fine.
- 10,000 Tulip Trees, 6 to 12 feet.
- 2,000 Weeping Mountain Ash.
- 50,000 Rose Bushes.
- A new Descriptive Catalogue and Wholesale List free.
- 21st Year. 403 Acres. 11 Greenhouses.
- Address, **STORRS, HARRISON & CO.,** Painesville, Lake Co., Ohio.

ROCHESTER COMMERCIAL NURSERIES. {Established, 1830.} ETC. If you wish to plant, send for our New Price List per doz., 100, 1,000, Autumn 1874—and save all commissions. Try it. Address, **W. S. LITTLE,** Rochester, N. Y.

FRUIT AND TREES! ORNAMENTAL TREES!

LARGE STOCK. LOW RATES. STANDARD PEAR-TREES A SPECIALTY. AGENTS WANTED. Address **E. MOODY & SONS, Lockport, N. Y.** NIAGARA NURSERIES, established 1839.

PEACH TREES!

A LARGE STOCK of old and new varieties; also of **CHERRY, APPLE, APRICOT, NECTARINES, and SEEDLINGS** for Nursery Planting. Wholesale List free. **HOOPES, BRO. & THOMAS,** Cherry Hill Nurseries, West Chester, Pa.

PEAR-TREES FOR THE MILLION.

Largest stock in the West; fine assortment; extra quality; packed to go safely any distance. Satisfaction guaranteed. Prices low by hundred or thousand. A full assortment of other trees, shrubs, plants, etc. Illustrated Catalogue mailed free to applicants. **R. G. HANFORD,** Columbus Nursery, Columbus, Ohio.

60,000 Fruit Trees.

APPLE, 2 to 5 years—\$10 to \$50 per M.
PEAR, Standard, 1 year—\$30 per M.
Price-List free. **HARVEY CURTIS,** Owego Nursery, Tioga Co., N. Y.

EARLY BEATRICE PEACH.

Ripe here July 23. Buds for sale. Send for Catalogue of Trees and Plants. **WILLIAM PARRY,** Cinnamonson, N. J.

APPLE SEEDLINGS.

Wild Goose and other Plum Trees, Peaches, Apples, and other nursery stock in large quantities. Address **THE TEBB NURSERIES CO.,** Clinton, Mo.

SENECA WHEAT,

Also called the **Clawson, Eureka, & Slauson.** This is the **BEST WHITE WHEAT** grown. We have also a good stock of **Treadwell, Fultz, Diehl, Red Mediterranean,** and other varieties. Also **PRIME WHITE RYE, GRASS SEEDS** of all kinds, etc., etc. For prices in large or small quantities address

R. H. ALLEN & CO.,
189 and 191 Water St.,
P. O. Box 376. New York City.

PRICES REDUCED.

Large stock of all the new and popular **PEACHES, EARLY BEATRICE, EARLY LOUISE, EARLY RIVERS, EARLY ALEXANDER,** also ten other new and well tested varieties of peaches, offered by no other nursery this season, among which is a large valuable well tested late peach, ripening two weeks after all other peaches are gone. Two shipments of this peach were made to Europe in 1874, via steamer from Baltimore. Both lots arrived out in fine order. A forty page catalogue, with descriptions, testimonials, and much valuable information of what and how to plant, mailed free on application. All kinds of nursery stock furnished at low rates. Address, **RANDOLPH PETERS,** Great Northern and Southern Nursery, Wilmington, Delaware.

Geneva Nursery. Established 1846.

400 Acres of Fruit and Ornamental Trees. **LARGE STOCK OF**
Pear Trees—extra size, Standard and Dwarf.
Apple Trees—first class, Standard and Dwarf.
Cherry Trees, Peach, Plum, Orange, Quince.
Grape Vines—New varieties and old approved sorts.
Large Stock of **Tree Roses**, grown by us especially for the Trade. Fine foraged trees, with Plants are grown on heavy clay soil, which makes them very hardy. All at lowest prices. Catalogues free. **W. & T. SMITH, Geneva, N. Y.**

FOR THE FALL TRADE.

We offer **Brandywine, Philadelphia, and Herstine Raspberries, American Seedling Gooseberries, 2 years, Conover's Asparagus, 1 to 3 years, Norway Spruce, and Deciduous Shrubbery** in variety, including the new **Hydrangea Paniculata.** Also **Concord and Ives Grape Vines.** **MASSEY & HUDSON,** Chestertown, Md.

WE offer for the fall of 1874 a complete stock of Trees and Plants. Our stock of Peaches, Plums and Cherries is the largest in the United States, and our list of new and rare fruits is always full. We are in a condition to offer advantages, and respectfully solicit correspondence. **THE HEIKES NURSERIES CO.,** Dayton, Ohio.

TO SOUTHERN NURSERYMEN!

Our long experience in supplying the wants of Southern Nurserymen, enables us to offer for this fall a stock of trees unsurpassed for the Southern market. Standard and Dwarf Pears, Apples, Cherries, Plums, &c., &c., in almost endless quantity. Send for Price List. **NICHOLAS & NEWSON, Geneva, N. Y.**

STRAWBERRY PLANTS

of the famous **Seth Boyden** (No. 30) variety, mailed, prepaid, at \$1.25 per 100. Other kinds also. Send stamp for Circular. Address **E. P. ROE** (author "Play and Profit in My Garden"), Highland Falls, Orange Co., N. Y.

Dutchess Nurseries. (Established 1863.)

Full price-lists now ready. All kinds of nursery and greenhouse stock. **Walter and Croton Grape Vines, Downing Gooseberries, La Versailles Currants, and Am. Arbor Vite specialties.** Prices very low. Send for Price-List. **W. L. FERRIS, JR., & CO., Poughkeepsie, N. Y.**

STANDARD PEARS.

An immense number of splendid trees. Several Blocks of different ages. All ready for Fall trade. An unbroken Block of 300,000, unequalled in this country. Also, a general Nursery Stock, very fine. Come and see. Send for Price List. **NICHOLAS & NEWSON, Geneva, N. Y.**

Early Beatrice, Louise, and Rivers' Peach Buds,

IN LARGE QUANTITIES AND MODERATE RATES. **FRANKLIN DAVIS & CO.,** Nurserymen, Richmond, Va.

STRAWBERRY PLANTS

of the choicest varieties for sale. Send stamp for Circular. Address **E. P. ROE** (author Play and Profit in My Garden), Highland Falls, near West Point, N. Y.

ROSES AND SMALL FRUITS BY MAIL. FREE

A catalogue of **Fruit and Shade Trees, Roses, Small Fruits, Vines and Bulbs.** Low rates, and special inducements. **WM. H. MOON,** Morrisville, Pa.

AGENTS LOOK!

—\$12 a day made selling Scissors Sharpener and other wares. Sample 25 cts. Catalogue free. **T. J. HASTINGS & CO.,** Worcester, Mass.

IMPORTANT TO FARMERS,

PLANTERS, PRINTERS, BREWERS, AND ALL USING STEAM POWERS.

ANDERSON'S PATENT STEAM BOILER AND KIPP'S NEW ENGINE.

Best and Cheapest in the World! HIGHEST AWARD.

Large Silver Medal at American Institute Fair, fall of 1873, for the best Portable Steam Boiler, 2 to 12 Horse Powers. Also, 1st and Highest Premiums at seven State Fairs and Expositions.

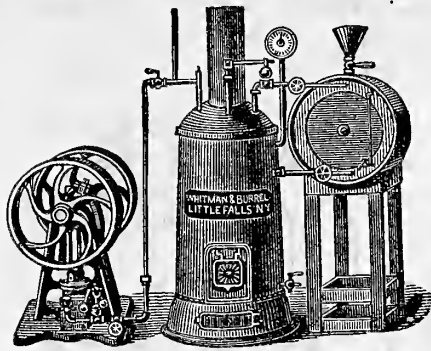

THIS IS NOT A FLUE BOILER.—It is a boiler within a boiler, the two connected together, and presenting an immense amount of heating surface to the fire, and also securing the Greatest Strength, Durability, and Effectiveness of any Steam Boiler yet introduced. Over 150 put in on trial, and never lost a sale.

25 to 30 per Cent Saved in Fuel—Five Sizes—2 to 10 Horse Power.—Will raise steam from cold water to 60 pounds pressure in 10 to 12 minutes. The Most Economical Combination Extant. Feeds itself from a Tank, and requires no more attention than an ordinary stove, and is just as safe. The engine is of the simplest possible form; the cylinder, bed, frame, guides, and bearings, being all cast in one piece, can not get out of line. Cheese and Butter Factory Apparatus and Fixtures.

WHITMAN & BURRELL, Manufacturers and Dealers, Little Falls, N. Y.

BLAKE'S PATENT STONE & ORE BREAKER.

New Pattern, with Important Improvements & Abundant Strength.

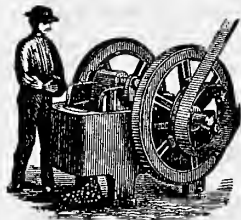

For reducing to fragments all kinds of hard and brittle substances, such as STONE for making the most perfect McADAM ROADS, and for making the best CONCRETE. It breaks stone at trifling cost for BALLASTING RAILROADS. It is extensively in use in MINING operations, for crushing

IRON, COPPER, ZINC, SILVER, GOLD, and other ORES.

Also for crushing Quartz, Flint, Emery, Corundum, Feldspar, Coal, Barytes, Manganese, Phosphate Rock, Plaster, Soapstone, etc. For Illustrated Circulars and particulars, address

BLAKE CRUSHER CO., New Haven, Conn.

Persons visiting New York, can be shown a crusher in operation at 137 Elm Street.

Samples from B. E. Hale & Co., 56 and 58 Park Place, N. Y. Sole Agents for Eastern States.

BUILDING PAPER!

FOR SHEATHING, ROOFING, DEAFENING, CARPET LINING AND PLASTERING.

Samples from Rock River Paper Company, Chicago, Ill.

The Lightning Peach-Parer.

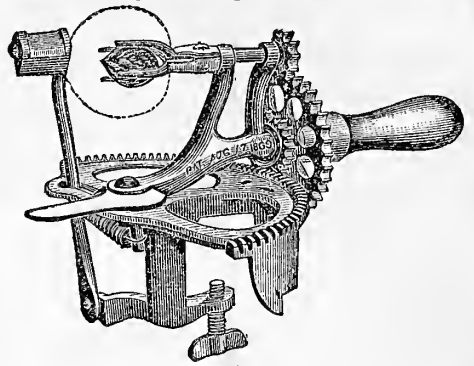

The only practical Peach-Parer made. It pares Apples as well as the best Apple-Parers. Sold in all large markets.

D. H. GOODELL, Sole Manufacturer, Antrim, N. H., and 99 Chambers-st., New York.

Also manufacturer of Improved Turn-Table Apple-Parers, Lightning Apple-Parers, Climax Corers and Slicers, Cahoon's Broadcast Seed-Sowers, etc.

CIDER MILLS.

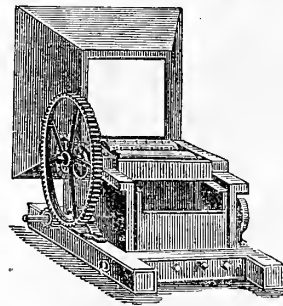

The most perfect Cider Apple Grinder in use, in grinding fast and fine, and giving the best satisfaction.

Price, \$40.

I have also the easiest, handiest, quickest working, and most powerful Press in use.

Send for Descriptive Circulars.

Address MARCUS P. SCHENCK, Fulton, N. Y.

THE FARMER'S Favorite Cider Mill.

Buy no Cider Mill until you have examined the Farmer's Favorite.

It is the best built, cheapest, and most durable Mill in market.

It will produce 25 per cent more juice from the same amount of cheese, than any other mill manufactured.

Send for Descriptive Circular. HIGGANUM MANUFACTURING COMPANY, Higganum, Conn.

Straw Preserving Thresher.



This Machine leaves the straw straight and unbroken, when it can again be put into bundles, making it more valuable for market. WHEELER & MELICK CO., Sole Manufacturers, Albany, N. Y. Send for circular.

Carbonized Enamel

IS AS PURE AS GLASS.

The Bridgeport M'f'g Co., OF BRIDGEPORT, CONN.

(Office, No. 88 Chambers St., New York). Have the exclusive control of this valuable enamel, and are using it to cover all of their celebrated

American Submerged Force Pumps.

They also enamel pipe inside and out, which delivers the water chemically pure. The Enamel is composed of vegetable matter, baked on so hard that a blow does not break it, and it resists acids that eat gold.

Gentlemen: I have examined the sections of Carbonized Enamel Pipe submitted to me by you. It is superior to any pipe I have ever seen for resisting acids and conducting water from springs or for use in connection with pumps, etc. The Enamel adheres with astonishing tenacity, withstanding even heavy blows; and the surface of the metal where the enamel is beaten off seems to be protected against the ordinary action of water.

M. C. WELD,

Late Associate Editor Am. Agriculturist.

MUDGE & WOODS, No. 88 Chambers St., N. Y., are the exclusive selling agents of the Bridgeport M'f'g Co. for the Licenses of States, counties, and towns rights for the American Submerged Suction and Force Pumps.

EVERY LADY SHOULD HAVE A SET OF GOODRICH'S "SPRING" TEMPERED HEMMERS

Consisting of Four Widths and a Dress Binder. Sent by Mail on Receipt of Price.

For Sale by all Sewing Machine Agents. H. C. GOODRICH, 205 State Street, CHICAGO, ILL. Price, Only One Dollar. H. C. GOODRICH, 103 N. 10th St., PHILADELPHIA, PA. Inventor of The Goodrich Tuck Marker.

MEDAL MACHINES.

NEW YORK STATE AGRICULTURAL WORKS.

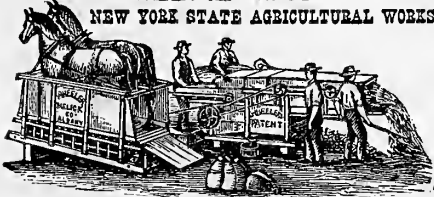

WHEELER & MELICK CO.,

Patentees and Manufacturers of RAILWAY, CHAIN AND LEVER HORSE POWERS, THRESHERS AND CLEANERS, THRESHERS AND SHAKERS, CLOVER HULLERS, FEED CUTTERS, ITHACA WHEEL HORSE RAKES, HORSE PITCHFORKS, SHINGLE MACHINES, STRAW PRESERVING RYE THRESHERS, &C., &C.

Send for Circular. ALBANY, N. Y.

HALL'S PATENT HUSKING GLOVES.

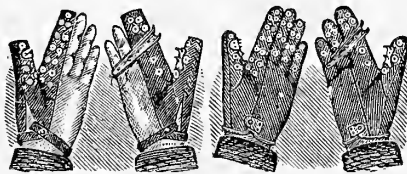

HALF GLOVES.

FULL GLOVES.

VERY GREATLY improved in form of the elaws and the more complete shielding of the parts subject to wear, (See cuts,) making them wear five times as long, and doing the work much faster and easier, than can be done with any other husker. Made of the very best calf leather, (tanned expressly,) in four sizes; right and left handed. Samples sent pre-paid on receipt of price. Half Gloves, \$1.25; Full Gloves, \$2.50 per pair. We also manufacture extra quality plain calf working Gloves and Mittens. Price, pre-paid, Mittens, \$1.40; Gloves, \$1.75 per pair. Liberal discount on all our goods in quantities. Ask your merchant, or address HALL HUSKING GLOVE CO., 145 So. Clinton-st., Chicago, Ill.

BUCKEYE DRIER BAKER AND FEED STEAMER

For full particulars, address ENGLE, KELLER & CO., Lancaster, Pa. CLAVELACK College and Hudson River Inst., at Clavelack, N. Y. Opens Sept. 7. ALONZO FLAOK, Ph. D., Pres.



Halladay's Improved Wind-Mill.

PERFECTLY Self-Regulating. The Best, Cheapest, most Durable and Popular Mill made. Manufactured under the immediate supervision of Inventor 18 years. Two million dollars' worth now in use. Send for Catalogue.

U. S. WIND ENGINE & PUMP CO. BATAVIA, ILL.

Four New Books!

(FOR AGENTS.)

OUR FIRST HUNDRED YEARS—12 monthly parts, 50 cts. each—2 parts now published.

Life and Public Services of Charles Sumner. 5th Edition. Revised and Enlarged.

Spirit of the Holy Bible.—Illustrated by the Old Masters. 600 Illustrations. Text in English, French, and German.

Maria Monk's Daughter. An Autobiography. Send for terms, specimen pages, and inducements.

UNITED STATES PUBLISHING COMPANY, 13 University Place, New York.

LIVINGSTONE IS DEAD.

For 30 years millions have INTENTLY watched the PERILOUS struggles and GRAND achievements of this world-renowned Hero, and now EAGERLY desire the Complete Life History which unfolds also the WEALTH and CURIOSITIES of a WILD and WONDERFUL country. It is NOW READY and SELLING to beat everything. MORE AGENTS WANTED AT ONCE. For Particulars of this, our superb NEW illustrated BIBLES, and OCEAN'S STORY, address HUBBARD BROS., Publishers, Philadelphia, Boston, or Cincinnati.

AGENTS WANTED FOR THE CENTENNIAL GAZETTEER OF THE UNITED STATES.

Showing the gigantic results of the "First 100 Years of the Republic." Agents make \$100 to \$300 per month. Send for circular. ZIEGLER & MURPHY, Philadelphia, Pa.; Springfield, Mass.

AGENTS WANTED FOR 'TELL IT ALL'

By Mrs. Stenhouse of Salt Lake City, 25 years the Wife of a Mormon High Priest. With Introduction by Mrs. Stowe. Over 300 Outfits of this new work were ordered by old Agents, in advance, who are now selling 25 to 40 a day! Its sale is without parallel. One lady sold 280 in one week. Terms big; sales positively immense. We send Outfit free to any one who will canvass. Agents wanted everywhere. Circulars free. Address, A. D. WORTHINGTON & Co., Hartford, Conn.

GOOD AGENT WANTED in every town or County, to receive orders from Banks, Business firms, Clergymen, Lawyers, schools, societies, and families. For writing paper of every description, printed note and letter heads, Envelopes, etc., all prices fully one-third below store rates. Large commission paid and orders (at the prices) are easily obtained. Persons (both Ladies and Gentlemen) who have received samples, are doing a fine business, and absolutely control the trade of their neighborhood. A complete and extensive outfit of samples, (worth \$1), with price list, and full instructions, will be sent, postage-paid, on receipt of 50 cents. \$50 to \$100 can be realized from them within ten days. Address THE EMPIRE CITY PAPER COMPANY, 51 Liberty street, New York, N.Y.—Persons who do not care to accept a regular AGENCY, can obtain their own supplies free, by getting up a club among their immediate friends.

The best Work Ever Issued for Farmers is

BELL'S Carpentry Made Easy.

It is useful to all who have barns, bridges, and out-houses to build, as it treats on the science and art of Framing on a new and improved system, with specific instructions for building Balloon Frames, Barn Frames, Mill Frames, Warehouses, etc.

Nicholson says of "Carpentry": "With an experience of more than twenty-four years at carpentering, I may say it is the best work of the kind I have ever had the good fortune to meet with."

JOHN J. NICHOLSON.

Another Carpenter says: "It is just the book for a young beginner."

PRICE, \$5.00, Prepaid.

HOWARD CHALLEN, Publisher, Philadelphia, Pa.

Schuckers' Life of

CHIEF-JUSTICE CHASE.

New York, July 10, 1874.

Messrs. D. APPLETON & Co., Publishers.

Gentlemen: We are gratified to learn that the "Life and Public Services of S. M. CHASE, Late Chief Justice of the United States," by Mr. J. W. Schuckers, and lately announced by you, is on the eve of publication. We hope it may find a large sale.

Mr. Schuckers' long and close association with Mr. Chase, in a confidential capacity, having been for many years and at his death his private secretary, peculiarly fits him, in our judgment, for writing a history of Mr. Chase's Life.

We know that this book is approved by all the members of Mr. Chase's family, and those of his friends who have examined advance sheets.

Very truly yours,

HIRAM BARNEY, Late Collector of Port of N. Y.
JOHN J. CISCO, Late Assistant Treasurer U. S.
CHAS. G. FRANKLYN, Agent of Cunard Line.
WILLIAM ORTON, Pres't Western Union Tel.

Sold by Subscription only. Applicants for Agencies should address the publishers.

How to Sell Good Books for All. New Instructions to Agents, now ready. Send stamp to S. R. WELLS, 389 Broadway, New York.

WEBSTER'S POCKET DICTIONARY

OF THE ENGLISH LANGUAGE.

Abridged from Webster's Quarto, illustrated with nearly TWO HUNDRED Engravings on Wood. This volume embraces a careful selection of more than 18,000 of the most important words of the language. The introduction contains, besides the Pictorial Illustrations, Tables of Money, Weight and Measure, Abbreviations, Words, Phrases, Proverbs, Etc., from the Greek, Latin, and the Modern Foreign Languages, Rules for Spelling, etc., etc.; making all together the most complete and useful pocket companion extant. It is beautifully printed on tinted paper, and bound in Morocco, Tucks, gilt edges, \$1. For sale everywhere. Sent by mail on receipt of the price.

IVISON, BLAKEMAN, TAYLOR, & CO. PUBLISHERS, 138 & 140 Grand Street, New York.

AGENTS wishing steady employment should canvass for **WONDERS OF THE GREAT DEEP.** A book of absorbing interest, filled with valuable information. Contains full accounts of Submarine Diving, Ocean Telegraphy, Arctic Discoveries, Whale Fisheries, &c., &c. Selling rapidly; price low. Elegantly illustrated; handsomely bound. Quaker City Pub. Co., Philadelphia.

"AROUND THE TEA-TABLE"

By REV. T. DEWITT TALMAGE, Author of "Crumbs Swept Up," &c.

"A string of pearls."
"Not a dry line in it—all gems."
"Every page aglow."
"Will have a Million Readers."

SOLD ONLY BY SUBSCRIPTION. Cowperthwait & Co., Philadelphia.

New Church Music Book, For 1874,—1875.

THE LEADER!!

By H. R. PALMER and L. O. EMERSON,

the most successful Church Music Book makers of the day. Will be ready in August, and will contain the usual Singing School Course, and a large amount of new and choice music for Choirs, Conventions and Singing Classes. Specimen Pages now ready, and will be mailed, post-free, on application.

Price, \$1.38, or \$12.00 per dozen.

The Emerson New Method FOR REED ORGANS.

By L. O. EMERSON and W. S. B. MATTHEWS. \$2.50. One of the Newest and very best of the New Methods.

GUIDE IN THE ART OF SINGING.

By Geo. L. Osgood, \$4.00.

New and very superior book for Voice Training.

Richter's Manual of Harmony.

Translated from the EIGHTH German edition, by J. C. D. PARKER. Price \$2.00.

Prepared expressly for the Leipzig Conservatory, and is a complete and reliable Grammar of Composition.

OLIVER DITSON & CO., CHAS. H. DITSON & CO., Boston. 711 B'dway, New York.

PIANOS for Rent.

with Privilege of Purchase. We Rent elegant first-class Pianos at very moderate rates, and allow the rent to pay for the instrument. By our new rental system a person can have from Two to Seven Years to pay for a Piano. Any responsible person wishing a first-class Piano on Easy Payments should send stamp for our new Illustrated Catalogue with full particulars. Address S. BRAINARD'S SONS, Cleveland, Ohio.

\$2500 A YEAR COMBINATION PROSPECTUS.

made with our grand. Represents 50 different books. Agents say this is the BEST THING EVER TRIED. The Books sell themselves in every family, and good men can make a business for life in one county. Agents Wanted on these and our magnificent Editions of Family Bibles. Full particulars free on application. Address JOHN E. POTTER & CO., Publishers, Philadelphia.

BAIRD'S BOOKS

For Practical Men.

- Duncan's Practical Surveyor's Guide.....\$1.25
- Bullock's American Cottage Builder..... 3.50
- A Treatise on the Manufacture of Vinegar..... 5.00
- Ville's School of Chemical Manures..... 1.25
- Miss Leslie's Complete Cookery..... 1.50
- Hughes' American Miller and Millwrights' Assistant..... 1.50
- Painter, Glider and Varinisher's Companion..... 1.50
- The Turner Companion..... 1.50
- Orton's Underground Treasures..... 1.50
- Smith's Practical Instructions in the Art of Dying..... 3.00
- Sloan's Homestead Architecture..... 4.50
- Wohler's Hand-Book of Mineral Analysis..... 3.00
- Smeaton's Builders' Pocket Companion..... 1.50
- Mechanics' (Amateur) Workshop..... 3.00
- Grant's Beet-root Sugar and Cultivation of the Beet.... 1.25
- Bryn's Complete Practical Distiller..... 1.50

And an Extensive Assortment of other Practical and Scientific Books.

My new revised and enlarged Catalogue, 96 pages, 8vo., will be sent, free of postage, to any one who will favor me with his address. HENRY CAREY BAIRD, Industrial Publisher, 406 Walnut-st., Philadelphia.

(When you write mention the American Agriculturist.)

Painter's Manual.—House and sign painting, graining, varnishing, polishing, kalsomining, papering, lettering, staining, gilding, glazing, silvering, glass staining, analysis of colors, harmony, contrast, etc. 50 cts. Book of Alphabets, 50. Book of Scrolls and Ornaments, 51. Watchmaker and Jeweler's Manual, 25. Taxidermist's Manual, 50. Soap-maker's Manual, 25. Guide to Antiquity, 30. Lightning Calculator, 25. Employment Seeker's Guide, 25. Of booksellers, or by mail. JESSE HANEY & CO., 119 Nassau st., New York.

ALL FARMERS and land owners should know what minerals are on their lands. For particulars address WM. L. BILLIN, Philadelphia, Pa. P. O. Box 2844.

FANCIER'S JOURNAL A Weekly devoted to Fowls, Pigeons, Rabbits, Dogs, Song Birds, etc. Send stamp for Specimen Copy. J. S. M. WADE, Philadelphia, Pa.

Trees and Shrubs, Camellias, Azaleas, Roses, Rhododendrons, &c., grown and offered in large quantity by R. B. PARSONS & Co., Flushing, L. I. Catalogues free.

BELLEVUE HOSPITAL MEDICAL COLLEGE.

CITY OF NEW YORK.

SESSIONS OF 1874-'75.

THE COLLEGIATE YEAR in this Institution embraces a preliminary Autumnal Term, the Regular Winter Session, and a Summer Session.

THE PRELIMINARY AUTUMNAL TERM for 1874-1875 will commence on Wednesday, September 16, 1874, and continue until the opening of the Regular Session. During this term, instruction, consisting of didactic lectures on special subjects and daily clinical lectures, will be given, as heretofore, by the entire Faculty. Students designing to attend the Regular Session are strongly recommended to attend the Preliminary Term, but attendance during the latter is not required. During the Preliminary Term, clinical and didactic lectures will be given in precisely the same number and order as in the Regular Session.

THE REGULAR SESSION will commence on Wednesday, September 30, 1874, and end about the 1st of March, 1875.

For the Annual Circular and Catalogue, giving regulations for graduation, and other information, address the Secretary of the College, Prof. AUSTIN FLINT, Jr., Bellevue Hospital Medical College.

Every package guaranteed above standard.

The Fertilizer for Fall Crops.

COMPOSED OF

Bones, Flesh, Blood, Calcined Bones, Phosphatic Guano, Potash, and Sulphuric Acid.

Ammonia, 3.57. Analysis on dry basis, April 9th, 1874; cargo, 319 tons; Sch. W. J. Parks; by Dr. I. Walz, New York.

Ammonia, 3.24. Analysis on dry basis, January 10th, 1864, by G. A. Liebig, Baltimore, Md.

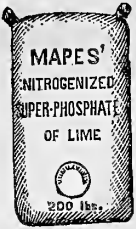

Barrels 250 lbs. net.

Liberal Inducements to Dealers.

Price reduced to \$50 per Ton. Packed in Barrels (250 pounds,) No Charge for Packages or Cartage.



BULBS FOR Present Planting! PLANTS FOR Parlor Culture!

Our Illustrated Catalogues of Dutch Bulbs, and Flower Roots, and Plants for House Culture, now ready and mailed free to all applicants.

Peter Henderson & Co. Seedsmen, 35 Cortlandt St., New York.

THE PULSOMETER.



The simplest, most durable, and efficient steam pump now in use. Will pump gritty or muddy water without wear or injury to its parts. It can not get out of order.

C. HENRY HALL & CO., 20 Cortlandt Street, New York City.

BRANCH DEPOTS: 104 Sudbury St., Boston, Mass. 1,327 Market St., Philadelphia, Pa. 59 Wells St., Chicago, Ill. South Western Exposition, New Orleans, La. 811 and 813 North Second St., St. Louis, Mo.

THE DRILL OF THE PERIOD.



The Superior Double Force-Feed GRAIN DRILL

Has met with unparalleled success during the past two years, and now stands without a rival in the Grain Drill family. It is the only Double Force-Feed Drill in the world. Thousands of farmers who have bought and used the "SUPERIOR," pronounce it entirely unequalled for perfection of work, ease of operating, grain saving, time saving, and money making. Don't fail to examine it and compare it with other Drills before purchasing.

THOMAS, LUDLOW & RODGERS, Manufacturers, Springfield, Ohio.

Also exclusive manufacturers of the celebrated Improved Buckeye and Champion Cider Mills. Send for Circulars.

TO PURCHASERS OF VEGETABLE SEEDS FOR FALL SOWING!

Our circular of instructions, with List of best varieties for above purpose, now ready, and mailed free on application.

Peter Henderson & Co. SEEDSMEN & GROWERS. 35 Cortlandt Street, New York.

ARE YOU GOING TO PAINT? OVER 200,000 HOUSES

PAINTED WITH THE Averill Chemical Paint.

White and all the fashionable shades mixed ready for use and sold by the gallon.

EXTRACTS FROM OUR LETTERS. HON. JAS. NEGLEY, Pittsburgh, Pa.: "Altogether I find the 'Averill' the cheapest and best." PETER HENDERSON, Esq.: "The 'Averill' has proved superior to lead and oil." C. W. SPOONER, Treas., Gordage Co., Plymouth, Mass.: "The 'Averill Chemical' has proved good." C. A. ALLYN, Esq., Palmyra, N. Y.: "The 'Averill Paint' is as bright to-day as when applied three years ago."

Hundreds of testimonials from owners of the finest residences in the country, with Sample Card of Colors, furnished free by dealers generally, and by the

AVERILL CHEMICAL PAINT CO., 32 Burling Slip, New York; or 132 East River St., Cleveland, Ohio.



Branch Office and Factory: 506 West Street, NEW YORK. Any Shade from Pure White to Jet Black.

A combination of the purest paint with India Rubber, forming a SMOOTH, GLOSSY, FIRM, DURABLE, ELASTIC, and BEAUTIFUL Paint, unaffected by change of temperature; is perfectly water-proof, and adapted to all classes of work; and is in every way a better paint for either inside or outside painting than any other paint in the world. Being from one-fourth to one-third cheaper, and lasting at least three times as long as the best lead and oil paints.

Be sure that our TRADE-MARK (a fac-simile of which is given above) is on every Package.

Prepared ready for use, and sold by the gallon only. There has never been a paint offered the public that has become so popular (in the same time) and given as perfect satisfaction as the Rubber Paint. Send for sample card and testimonials.

W. A. COVERT & CO., Produce Commission Merchants, No. 68 Pearl Street, New York. Quick sales and prompt returns. Send for our weekly Prices-current and Marking Plate.

State, County, and other Fairs for 1874.

State Fairs.

Table listing State Fairs for 1874, including California, Colorado, Connecticut, Georgia, Illinois, Indiana, Iowa, Kansas, Maine, Maryland, Minnesota, Mississippi, Montana, Nebraska, New England, New Hampshire, New Jersey, New York, North Carolina, Ohio, Oregon, Pennsylvania, Vermont, Virginia, West Virginia, and Wisconsin.

District and Union Fairs,

Table listing District and Union Fairs for 1874, including Antwerp Union, Blanford Union, Cambridge City, Ct. River Valley, Ct. Stock Breeder's Ass., Deerfield Valley, De Kalb Union, District Fair Associat'n, Dog River Valley, Dubuque District, Edinburgh Union, Ford Union, Fountain & Warren, Fountain, Warren, & Vermillion, Fulton District, Gosport District, Hartford Central, Hoosac Valley, Indiana, North East'n, Indiana, South East'n, Iroquois District, Jo Davies Union, Lamoille Valley, Logan Union, Mad River Valley, Marshall District, Marshall Union, Michigan Eastern, Mitchell District, Montgomery District, Mooresville District, Nebraska Southern, New York Central, Ohio Central, Ohio Central, Ohio Central, Ohio Northern, Ohio Southern, Oneonta Union, Palmyra Union, Pennsylvania, East., Perry Union, Phenix Union, Prairie Farmer District, Racket & St. Regis Valley, St. Lawrence Valley, Schenueus Valley, Susquehanna Valley, Switzerland & Ohio Dist., Trenton Union, Thornton District, Union City District, Vermillion District, Wellington Union, White River Valley, Whiteside District, Winfield Union, Wisconsin Northern, Wisconsin Southern.

Industrial Fairs.

Table listing Industrial Fairs for 1874, including American Institute, Annsville and Lee, Cincinnati, Franklin Institute, Kansas City, Louisville, Richmond, St. Joseph, Wis. Industrial Ass'n, and Worthington.

Provincial Fairs.

Table listing Provincial Fairs for 1874, including Guelph Central, Ontario Provincial, Ontario Western, N. S. Fruit Growers' Ass'n, and N. S. Yarmouth.

Horticultural Fairs.

Table listing Horticultural Fairs for 1874, including Horticultural, Maine Pomological, Massachusetts Horticult', Michigan Pomological, Newburgh Bay, Pennsylvania, and Worcester Hort.

Poultry Shows.

Table listing Poultry Shows for 1874, including Bucks Co., Pa., and Central New York.

Table listing county fairs for Connecticut, Eastern Pennsylvania, Illinois, Iowa, Lehigh Valley, Pa., Maine, Maryland, Massachusetts, New England, and Western New York.

County and Town Fairs.

MAINE.

Table listing county fairs for Maine including Aroostook, Cumberland, Franklin, Franklin North, Knox, Knox North, Lincoln, Oxford South, Oxford East, Oxford West, Penobscot West, Piscataquis West, Sagadahoc, Somerset West, and Washington.

NEW HAMPSHIRE.

Table listing county fairs for New Hampshire including Canterbury Town, Cheshire, Cotoocook, Coos, Grafton, Hillsboro', Merrimack, and Strafford.

VERMONT.

Table listing county fairs for Vermont including Addison, Caledonia, Franklin, and Washington.

MASSACHUSETTS.

Table listing county fairs for Massachusetts including Barnstable, Berlin, Berkshire, Bristol, Bristol Center, Essex, Franklin, Grafton, Hampden, Hampden East, Hampshire, Hampshire Franklin, and Hampden.

RHODE ISLAND.

Table listing county fairs for Rhode Island including Woonsocket.

CONNECTICUT.

Table listing county fairs for Connecticut including Fairfield, Guilford, Milford and Orange, New Haven, New London, Ridgefield, Tolland, Union, Wallingford, Watertown, and Woodbridge & Bethany.

NEW YORK.

Table listing county fairs for New York including Albany, Alleghany, Broome, Cattaraugus, Cayuga, Chautauqua, Chemung, Chenango, Chenango, Clyde, Columbia, Cortland, Delaware, Dutchess, Dutchess, Edmeston & Burlington, Erie, Essex, Excelsior, Franklin, Genesee, Greene, Hampton, Hudson, Iroquois, Lewis, Madison, Madison, and Montgomery.

Table listing county fairs for New Jersey including Burlington, Monmouth, Somerset, Berks, Centre, Chester, Chesier, Columbia, Fayette, Greene, Greenc, Lehigh, Luzerne, Lycoming, Northampton, Northumberland, Oxford, Schuylkill, Susquehanna, Washington, Westmoreland, and Wyoming.

NEW JERSEY.

Table listing county fairs for New Jersey including Burlington, Monmouth, and Somerset.

PENNSYLVANIA.

Table listing county fairs for Pennsylvania including Berks, Centre, Chester, Chesier, Columbia, Fayette, Greene, Greenc, Lehigh, Luzerne, Lycoming, Northampton, Northumberland, Oxford, Schuylkill, Susquehanna, Washington, Westmoreland, and Wyoming.

OHIO.

Table listing county fairs for Ohio including Allen, Ashtabula, Ashtabula, Athens, Belmont, Brown, Butler, Carroll, Champaign, Clermont, Clinton, Clyde, Columbiana, Coshocton, Crawford, Cuyahoga, Darke, Defiance, Delaware, Erie, Fayette, Franklin, Fulton, Gallia, Geauga, Greene, Guernsey, Hamilton, Hancock, Hardin, Harrison, Highland, Holmes, Huron, Jefferson, Knox, Licking, Logan, Lorain, Lucas, Mahoning, Marion, Medina, Mercer, Montgomery, Morgan, Morrow, Muskingum, Ottawa, Paulding, Perry, Preble, Ross, Sandusky, Seneca, Shelby, Stark, Summit, Trumbull, Tuscarawas, and Union.

Table listing county fairs for Van Wert, Warren, Washington, Wayne, Williams, and Wyandot.

INDIANA.

Table listing county fairs for Indiana including Allen, Boone, Boone, Cass, Clinton, Coles, Davies, Delaware, Dubois, Fayette, Fall Creek, Franklin, Fulton, Grant, Greene, Gibson, Hamilton, Harrison, Howard, Huntington, Jackson, Jasper, Jay, Jefferson, Johnson, Knox, Lagrange, Lake, Laporte, Lawrence, Madison, Marion, Marshall, Monroe, Morgan, Parke, Perry, Pike, Porter, Posey, Putnam, Randolph, Rush, Starke, Tippecanoe, Vanderburgh, Vermillion, Vigo, Wabash, Warrick, and Wells.

ILLINOIS.

Table listing county fairs for Illinois including Brown, Bureau, Carroll, Cass, Champaign, Clay, Coles, Crawford, Cumberland, De Kalb, De Witt, Douglass, Du Page, Edgar, Edwards, Effingham, Effingham, Ford, Franklin, Fulton, Gallia, Greene, Henderson, Iroquois, Jasper, Jefferson, Jersey, Jo Daviess, Kendall, La Salle, Lawrence, Lee, Livingston, Logan, Macon, McDonough, McHenry, McLean, Macoupin, Madison, Marion, Mason, Menard, Mercer, Montgomery, Morgan, Monttrie, Ogle, Pike, Pope, Putnam, Rock Island, Sangamon, St. Clair, Schuyler, Shelby, Stephenson, Union, Vermillion, Wabash, and Warren.

Wayne.....	Fairfield.....	Sept 15-18
Will.....	Joliet.....	Sept. 8-11
Williamson.....	Marion.....	Oct. 6-9
Winnebago.....	Rockford.....	Sept. 1-4
Woodford.....	Metamora.....	Sept. 2-4

MICHIGAN.

Branch.....	Sept. 23-26
Eaton.....	Charlotte.....	Sept. 23-24
Ottawa.....	Berlin.....	Sept. 22-24
Sanilac.....	Lexington.....	Oct. 7-8
Van Buren.....	Paw Paw.....	Sept. 23-25

WISCONSIN.

Adams.....	Friendship.....	Sept. 29-30
Buffalo.....	Alma.....	Sept. 23-24
Clark.....	Neillsville.....	Sept. 15-17
Columbia.....	Portage.....	Sept. 29-Oct. 1
Dane.....	Madison.....	Sept. 23-24
Fond du Lac.....	Fond du Lac.....	Sept. 23-24
Grant.....	Lancaster.....	Sept. 2-4
Green.....	Monroe.....	Sept. 23-26
Jefferson.....	Jefferson.....	Sept. 23-25
Kewaunee.....	Kewaunee.....	Sept. 24-26
Lafayette.....	Darlington.....	Sept. 17-19
Lodi.....	Lodi.....	Sept. 15-18
Marathon.....	Wausau.....	Sept. 24-26
Monroe.....	Monroe.....	Sept. 23-24
Outagamie.....	Appleton.....	Sept. 23-24
Portage.....	Amherst.....	Sept. 22-24
Richland.....	Richland Center.....	Sept. 16-18
Ripon.....	Ripon.....	Sept. 15-17
Rock.....	Beloit.....	Sept. 15-17
Sank.....	Baraboo.....	Sept. 14-16
Sheboygan.....	Sheboygan Falls.....	Sept. 16-18
Shullsburg.....	Shullsburg.....	Sept. 10-12
Walworth.....	Elkhorn.....	Sept. 29-Oct. 2
Waukesha.....	Waukesha.....	Oct. 7-9
Waupun.....	Waupun.....	Oct. 1-3

MINNESOTA.

Blue Earth.....	Garden City.....	Sept. 17-19
Meeker.....	Litchfield.....	Oct. 7-9
Scott.....	Jordan.....	Sept. 2-3
Wabashaw.....	Wabashaw.....	Sept. 28-29

IOWA.

Allamakee.....	Waukon.....	Sept. 22-24
Guthrie.....	Guthrie Centre.....	Sept. 2-4
Jones.....	Monticello.....	Sept. 2-4
Kossuth.....	Algona.....	Oct. 7-8
Lyon.....	Rock Rapids.....	Sept. 16-18
Polk.....	Des Moines.....	Sept. 4-17
Tama.....	Toledo.....

MISSOURI.

Adair.....	Kirksville.....	Sept. 15-18
Boone.....	Columbia.....	Sept. 9-13
Boone.....	Sturgeon.....	Sept. 1-5
Cape Girardeau.....	Cape Girardeau.....	Sept. 1-6
Clark.....	Waterloo.....	Oct. 7-10
Holt.....	Oregon.....	Sept. 1-5
Louisiana.....	Louisiana.....	Oct. 12-18
Macon.....	Macon.....	Sept. 18-19
Nodaway.....	Maryville.....	Sept. 15-19
Platte.....	Platte.....	Aug. 31-Sept. 4
Putnam.....	Unionville.....	Oct. 1-3
St. Francois.....	Farmington.....	Sept. 15-20
St. Louis.....	St. Louis.....	Oct. 5-11
Washington.....	Potosi.....	Sept. 1-5

KANSAS.

Allen.....	Iola.....	Oct. 7-10
Anderson.....	Garnett.....	Sept. 16-18
Atchison.....	Atchison.....	Sept. 4-7
Brown.....	Hiawatha.....	Sept. 24-26
Butler.....	Sept. 23-25
Coffey.....	Burlington.....	Sept. 23-25
Cowley.....	Winfield.....	Sept. 1-3
Cherokee.....	Baxter Springs.....	Sept. 23-25
Crawford.....	Girard.....	Oct. 7-9
Dickinson.....	Enterprise.....	Sept. 23
Franklin.....	Ottawa.....	Sept. 23-26
Greenwood.....	Eureka.....	Sept. 23-24
Harvey.....	Newton.....	Sept. 3-4
Jackson.....	Holtton.....	Sept. 2-4
Lyon.....	Emporia.....	Sept. 23-25
Miami.....	Paola.....	Sept. 23-26
Mitchell.....	Beloit.....	Sept. 23-26
Montgomery.....	Independence.....	Sept. 29-Oct. 1
Ottawa.....	Minneapolis.....	Sept. 23-25
Pottawatomie.....	Louisville.....	Sept. 28-30
Riley.....	Mauhattan.....	Sept. 29-Oct. 2
Republic.....	Sept. 16-18
Shawnee.....	Topeka.....	Sept. 23
Smith.....	Smith Centre.....	Sept. 24-25
Wabunsee.....	Alma.....	Sept. 30-Oct. 1
Washington.....	Washington.....	Sept. 15-17

NEBRASKA.

Cass.....	Plattsmouth.....	Sept. 15-17
Cuming.....	West Point.....	Sept. 10-12
Dodge.....	Centralia.....	Sept. 1-3
Douglas.....	Omaha.....	Sept. 23-26
Gage.....	Beatrice.....	Sept. 16-18
Johnson.....	Tecumseh.....	Sept. 23-25
Madison.....	Norfolk.....	Sept. 23-25
Nemaha.....	Brownville.....	Sept. 23-25
Otoe.....	Syracuse.....	Sept. 16-19
Sarpy.....	Papillion.....	Sept. 15-17
Seward.....	Seward.....	Oct. 7-9
Washington.....	Blair.....	Sept. 16-18

KENTUCKY.

Bourhon.....	Paris.....	Sept. 1-5
Fleming.....	Mt. Carmel.....	Sept. 15-23
Henderson.....	Henderson.....	Oct. 12-16
Jefferson.....	Louisville.....	Sept. 1-5
Mason and Bracken.....	Oct. 6-10
Marion.....	Lebanon.....	Sept. 8-12
Mason.....	Germanatown.....	Oct. 6-12
Owen.....	New Liberty.....	Oct. 12-17

TENNESSEE.

Greene.....	Greeneville.....	Sept. 23-25
Washington.....	Johneshorough.....	Sept. 30-Oct. 2

"UP FOR REPAIRS,"

A Beautiful, New Picture for Every Subscriber to the

American Agriculturist

FOR 1874.

An exquisite Oil Painting by the celebrated American Painter, Mr. B. F. Reinhart, executed expressly for the American Agriculturist and entitled

"UP FOR REPAIRS,"

has been most successfully reproduced in Chromo by the well-known firm of Bencke & Scott. It is a picture of a scene in childhood, which many will recognize as what they have themselves witnessed or been actors in, and can not fail to please both old and young.

The Publishers will give this beautiful Chromo

To Every Subscriber

to this paper for the year 1874 received after this date, as detailed below. It is ready for immediate delivery at 245 Broadway, Free of Charge.

If to go by mail, 10 cents must be sent to cover cost of packing and postage. For 25 cents it will be Mounted, Varnished, Packed, and sent Post-paid.

N. B.—The Chromo will be delivered: At the Office, Unmounted, Free. " " Mounted, 15 cents extra. Sent by Mail, Unmounted, 10 cents extra. " " Mounted, 25 cents extra.

We advise all to have them mounted before leaving the office, as in the large quantities we put up we are able to mount them for a quarter of the cost of doing it singly, and better than it can usually be done elsewhere.

The picture is designed for every subscriber upon the terms stated above, which please read carefully; and on these terms all are alike entitled to it, whether their names come singly at \$1.50 each, or in Clubs of Four for \$5, or Clubs of Ten at \$1.20 each, or in Clubs of Twenty or more at \$1 each. Subscribers in Premium Clubs will also thus be entitled to it.

N. B.—A few of the beautiful pictures entitled "MISCHIEF BREWING," which have been given to so large a number of subscribers, are still in stock, and, while any remain, subscribers to the American Agriculturist can have their choice between this and the new Chromo "UP FOR REPAIRS"; but the choice must be named at time of subscribing. ORANGE JUDD COMPANY, 245 BROADWAY, NEW YORK.

Money IN THE GARDEN.

A VEGETABLE MANUAL,

PREPARED WITH A VIEW TO

ECONOMY AND PROFIT,

BY P. T. QUINN,

PRACTICAL HORTICULTURIST.

In this work the author aims to give, in a plain, practical style, instructions on three distinct although closely connected branches of gardening—the kitchen-garden, market-garden, and field culture; the only and sufficient credentials for the fitness of his undertaking being a successful practical experience for a term of years.

CONTENTS.

Chapter I. Money in the Garden.	Chapter VIII. Melons.
" II. Hot-beds.	IX. Onions.
" III. Artichoke.	X. Parsley.
" IV. Beans.	XI. Radishes.
" V. Cabbages.	XII. Salsify.
" VI. Egg-Plants.	XIII. Tomatoes.
" VII. Lettuce.	XIV. Forcing Houses.
Chapter XV. List of Seeds.	

PRICE, POST-PAID - - - - - \$1.50

ORANGE JUDD COMPANY,

245 BROADWAY, NEW YORK.

Beckwith Sewing Machine

ONLY \$20.

We have offered as a Premium, and also for sale, for more than a year past, the Beckwith Sewing Machine, which has been fully described in previous numbers of this paper. We have already given and sold more than one thousand of these machines, and testimonials of satisfaction have come from every quarter.

The Beckwith Sewing Machine Company has from time to time added improvements to their original Machines, which have been sold for \$12. They now manufacture only

THE BECKWITH PORTABLE FAMILY SEWING MACHINE.

PRICE \$20.

Enlarged and Improved. Its Weight is 7 Pounds.

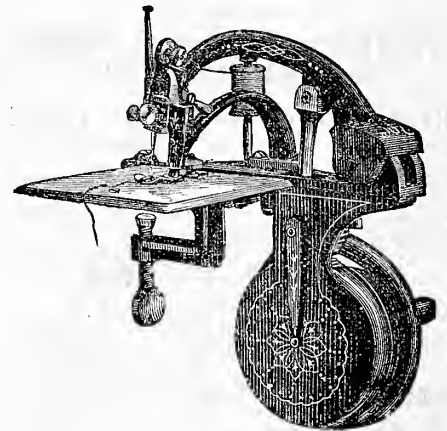

PORTABLE FAMILY MACHINE.

A new and very simple braiding-foot has been made, by which a child can sew on braid without the least trouble, following any desired pattern with ease; also a new arm, spiral spring and lever for raising the presser-foot, all of which are now set in a position that leaves the needle free to be threaded. The joint is much enlarged, and the machine is otherwise greatly strengthened and improved. The use of the braider-foot alone will be valued more than the cost of the machine.

The \$20 Portable Family Machine

Comprises all the excellences of the former machines, with many valuable improvements. Its size and power are increased, and its capacity thus very much enlarged, without impairing its portability. There have been added cam and eccentric movement, a balance-wheel, and also an oscillating needle-clamp, by which the length of stitch can with the greatest ease be changed to the finest shade of variation without touching the needle.

Each of these machines is put in a neat, compact box, with hemmer and guide, oil-can with oil, thread, different-sized needles, etc., with full Printed Directions for using.

To any one sending us \$20, we will send one of the Machines (packed in a neat, portable case, with handle to carry it easily), expressage to be paid by purchaser.

The Machine as a Premium.

We will give one of these \$20 Machines to any one who will collect and forward to us Thirty Subscribers to American Agriculturist for one year at \$1.50 each, or One Hundred at \$1 each, expressage on the Machine to be paid by the recipient of it.

Almost any lady can readily secure the small number of subscribers required to get this Machine as described above; or some friend can thus obtain it for her as a present.

ORANGE JUDD COMPANY,

245 BROADWAY, NEW YORK.

TREES, Etc.

AUTUMN OF 1874.

We invite the attention of Planters and Dealers to our large and complete stock of

- Standard and Dwarf Fruit Trees.
 - Grape Vines, Small Fruits.
 - Ornamental Trees, Shrubs, Roses.
 - New & Rare Fruit & Ornamental Trees.
 - Evergreens and Bulbous Roots.
 - New & Rare Green & Hot House Plants.
- Small parcels forwarded by mail when desired.

Prompt attention given to all inquiries.

Descriptive and Illustrated Priced Catalogues sent prepaid on receipt of stamps, as follows:

- No. 1—Fruits, 10c.
 - No. 2—Ornamental Trees, 10c.
 - No. 3—Greenhouse, 10c.
 - No. 4—Wholesale, Free.
- Address
Establish'd 1840.

ELLWANGER & BARRY,

Mount Hope Nurseries, ROCHESTER, N. Y.

PHILADELPHIA, June 11, 1874.

N. GUILBERT, Gwynedd, Pa.—Enclosed is sample of wool of a yearling ewe, bred from the ewe Cotswold that I ordered from you for Mr. Keller, at Akron, Pa.; the wool of the yearling weighed 16½ lbs., and speaks very well for your stock. He intends having it advertised in the Lancaster newspapers. He sold all his other sheep.

Yours, etc., A. R. FRASER, No. 415 S. Second St. Always on hand and for sale, Cotswold Sheep, Southdowns, Blooded Live Stock, Horses, Cows, Calves, Swine, Geese, Ducks, Turkeys, Fancy Fowls, Peacocks, Dogs, Maltese Cats, Rabbits, Guinea Pigs, White Mice, Deer, Swan, Pigeons, etc. A noble pair of thoroughbred Mastiffs, and an elegant English Greyhound Dog. Wanted—Deer, Swan, and Wild Geese. N. GUILBERT, Evergreen Farm, Gwynedd, Pa.

Stephen Hoyt & Sons, NEW CANAAN, CONN.,

Offer for sale a very large and superior stock of FRUIT AND ORNAMENTAL TREES, consisting largely of Apple and Peach Trees. Also, Cherry, Pear, and Plum Trees.

A splendid lot of Concord, and other Vines, one and two years old. 75,000 La Versailles, Cherry, and White Grape Currants. 200,000 Apple Seedlings, two years old, etc., etc.

DWARF PEARS.

A large stock of two-year old trees, very fine. Also, Standard Pears, Apples, Plums, Cherries, &c., &c. Inspection invited. Correspondence solicited. NICHOLAS & NEWSON, Geneva, N. Y.

Climbing Fern, or Lygodium Palmatum.

Pressed or unpressed, sent in perfect order to any part of the country. Enclose stamp. REED WATSON, East Windsor Hill, Ct.

THE PEOPLE'S Force Pumps.



Awarded medal of American Institute over all competitors last fall. For the house and out of doors. Non-freezing, and adaptable to wells from 6 to 100 feet deep. Highly recommended for city houses on account of their great power. Parties about to supply themselves are invited to call and examine. Circulars sent on application. Plumbers are particularly requested to call. See Ogden Farm Papers, Dec., 1871. See "Notes from the Pines," on page 182, May number, of American Agriculturist, 1874.

Certain parties, with the intent to profit by the well earned reputation of these pumps, the result of faithful manufacture, having imitated them, the public are cautioned to look for the name, "People's Pump," Patented Aug. 31, 1859, cast on the lid, to insure obtaining the genuine article, and to avoid litigation.

W. S. BLUNT, 77 Beekman Street, New York.

The Hutchinson Burner.

(Price, 35 Cents, by Mail.) No chimney needed. Fits the common lamps, and burns kerosene with a clear, steady flame two inches high, or any less light desired. For safety, convenience, and economy, unequalled. Sent by mail for 35 cents; two for 60c., with wicks. Write to HUTCHINSON & CO., Cayuga, N. Y.



WANTED, by an American boy, a situation in one of the Western States, where he can learn to be a practical Farmer. He is 16 years of age, is willing to work, and make himself useful. Any Farmer (in Illinois, Iowa, or Indiana, preferred) wishing such a boy, will please address THOMAS C. PATTERSON, 1,157 Mary Street, Elizabeth, New Jersey.

Improved Foot Lathes.

Small Engine Lathes, Small Gear Cutters, Hand Planers for Metal, Bull Turning Machines, Slide Rests, Foot Scroil Saws. The very best. Selling everywhere. Catalogues free. N. H. BALDWIN, Laconia, N. H. Just the articles for Artisans or Amateurs.



Auction Sale of Jersey Cattle.

Will be sold at Auction, without reserve, on Thursday Morning, September 24th, 1874, at 11 o'clock, at

HERKNESSES' BAZAAR, Philadelphia, Pa.,

The entire herd of pure bred Jersey cattle, the property of J. Howard McHenry, Esq., Sudbrook Farm, Pikesville P. O., Baltimore County, Maryland. The herd consists of 25 head, cows, heifers, and bulls, all registered, and for purity of breeding and fashionable colors, it is believed can not be excelled in this country.

Catalogues on application. Stock on view the day previous to day of sale. ALFRED M. HERKNESSES & CO., Auctioneers, 9th and Sansom Sts., Philadelphia, Pa.

P-E-T-R-O-L-E-U-M.

CRUDE AND REFINED.

CRUDE PETROLEUM is unexcelled as a wash to preserve Fences, Shingle Roofs, Agricultural Implements, and wood of any kind, from decay, and Metal from rusting.

REFINED PETROLEUM for light is safe, pure, of standard legal test, and cheap.

Save two or three commissions by ordering one barrel or fifty direct from the Oil Regions of Pennsylvania.

Address a reader of the Agriculturist. GEO. M. LYONS, Titusville, Pa.

GAWTHROP'S IMPROVED HYDRAULIC RAMS. Send for Illustrated Circular and Price-List. A. GAWTHROP & SON, Wilmington, Del.

SILVER & SCHILLING, Cleveland, O. Pure unburnt Bone-dust is declared to be the best for wheat. Send for Price-List.

THE PATENT

ARION

PIANO-FORTE

Excels all others in Tone and Durability, and in Elegance of Finish they are Unsurpassed.

These Pianos are used exclusively in the New York Conservatory of Music, and are recommended by the Profession and the Press throughout the United States.

Before purchasing, write for Illustrated Pamphlet, and mention the Agriculturist.

ARION PIANO-FORTE CO., No. 5 East 14th Street, New York City.

NEW DIPLOMAS FOR AGRICULTURAL SOCIETIES.

Specimens supplied by The Major & Knapp Engraving, Mfg. and Lithographing Co. 56 & 58 Park Place, N. Y.



LOVEJOY'S METALLIC WEATHER HOUSES

Indicate the changes in the weather, and are pretty mantel ornaments. The little lady appears in fair and the man in stormy weather, and they never make mistakes. Sent prepaid to any address, safely packed, upon receipt of \$2 (Two), by ALVAN L. LOVEJOY, Proprietor and Manufacturer, 229 Washington St., Boston.

Special price to dealers.

FANCIER'S JOURNAL A Weekly devoted to Fowls, Pigeons, Rabbits, Dogs, Song Birds, etc. Send stamp for Specimen Copy. JOS. M. WADE, Philadelphia, Pa.

Lovejoy's New Style GLASS CUTTER And Putty Knife

Cuts glass better than a diamond. Everybody should have one. Any child can use it. Sent to your address on receipt of 50c. and stamp by ALVAN L. LOVEJOY, 229 Washington St., Boston, - - - Mass.

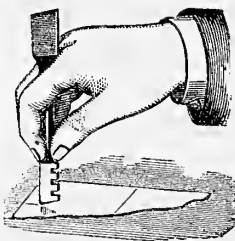

Liberal Discount to Wholesale and Retail Dealers.

Farm for Sale. Rare Chance

to buy a farm under good cultivation, 100 acres; well watered; suitable for stock-breeding, dairy, or tobacco. Good buildings. 15 miles from Hartford; 2 miles from R. R. Station; 1½ miles from six churches, good schools, and markets. Fine herd of Jerseys can go with farm, if desired, (or sold separately). Address EDWARD PAYSON, Bristol, Conn.

GOTHIC FURNACE.

For Warming Houses, Schools, Churches.

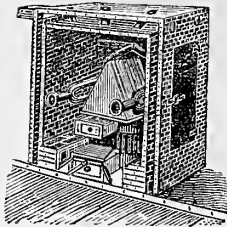

The best Heating Apparatus in use.

Grand Award American Institute, 1863.

Send for Catalogue.

ALEX. M. LESLEY, Manufacturer, 224 & 226 West Twenty-third St., New York.

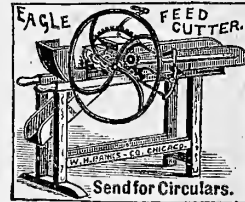

Effective! Durable! Every Machine Arranged to Cut 5 Lengths.

(The Farmer, The Dealer, Everybody) WANTING A

FEED CUTTER.

W. H. BANKS & CO., General Agents, 34 & 36 S. Canal St., Cor. Wash'ton, CHICAGO.

A Man of Honor.

By GEORGE CARY EGGLESTON. Finely Illustrated.

NOTICES BY THE PRESS.

A capital picture of Life in Old Virginia before the war is to be found in Mr. George Cary Eggleston's "A Man of Honor." Virginian hospitality, Virginian cousinship, Virginian housekeeping, are portrayed in accurate and attractive colors. It is a life which the author has himself known and loved, and he writes of it with a warmth that comes from the heart.—N. Y. Evening Post.

Really readable in the most refreshing sense of the term—a story of the most amusing and attractive interest.—St. Louis Times.

It is written in an off-hand manner, and is bright and amusing.—Worcester, (Mass.) Spy.

With Virginian life as a specialty, Mr. Eggleston has drawn a simple, straightforward, truthful, and withal, artistic picture of Southern society. It is sketchy, perhaps too much so, but the sketches are all vigorous and show the hand of a practiced artist. In forming the characters of his book it is evident that Mr. Eggleston has drawn oftener on his memory than on his imagination; that he has lived among the people whom he describes, has heard them talk, and seen them under all the moods of ordinary life.—Boston Daily Advertiser.

CONTENTS.

Chapter 1. Mr. Pagebrook gets up and calls an Ancient Lawgiver.—2. Mr. Pagebrook is Invited to Breakfast.—3. Mr. Pagebrook Eats his Breakfast.—4. Mr. Pagebrook Learns Something about the Customs of the Country.—5. Mr. Pagebrook Makes some Acquaintances.—6. Mr. Pagebrook Makes a Good Impression.—7. Mr. Pagebrook Learns Several Things.—8. Miss Sudie Makes an Apt Quotation.—9. Mr. Pagebrook Meets an Acquaintance.—10. Chiefly Concerning "Foggy."—11. Mr. Pagebrook Rides.—12. Mr. Pagebrook Dines with his Cousin Sarah Ann.—13. Concerning the Rivulets of Blue Blood.—14. Mr. Pagebrook Manages to be in at the Death.—15. Some very Unreasonable Conduct.—16. What Occurred Next Morning.—17. In which Mr. Pagebrook Bids his Friends Good-by.—18. Mr. Pagebrook Goes to Work.—19. A Short Chapter, not very Interesting, perhaps, but of some Importance in the Story, as the Reader will probably Discover after awhile.—20. Cousin Sarah Ann Takes Robert's Part.—21. Miss Barksdale Expresses some Opinions.—22. Mr. Sharp Does his Duty.—23. Mr. Pagebrook Takes a Lesson in the Law.—24. Mr. Pagebrook Cuts Himself Loose from the Past and Plans a Future.—25. In which Miss Sudie Acts very Unreasonably.—26. In which Miss Sudie adopts the Socratic Method.—27. Mr. Pagebrook Accepts an Invitation to Lunch and Another Invitation.—28. Major Pagebrook Asserts Himself.—29. Mr. Barksdale the Younger goes upon a Journey.—30. The Younger Mr. Barksdale Asks to be Put upon his Oath.—31. Mr. William Barksdale Explains.—32. Which is also the Last.

ILLUSTRATIONS.—By M. WOLF.

"Now I've Got You" (Frontispiece).—Mr. Robert Pagebrook was "Blue."—"I Fall at Once into a Chronic State of Washing up Things."—"Foggy."—Cousin Sarah Ann.—The Rivulets of Blue Blood.—Miss Sudie Declares Herself "so Glad."—"Let Him Serve it at Once, Then."—"Very Well, Then."—"I'm as Proud and as Glad as a Boy with Red Morocco Tops to his Boots."

PRICE, POST-PAID\$1.25

ORANGE JUDD COMPANY, 245 BROADWAY NEW YORK.

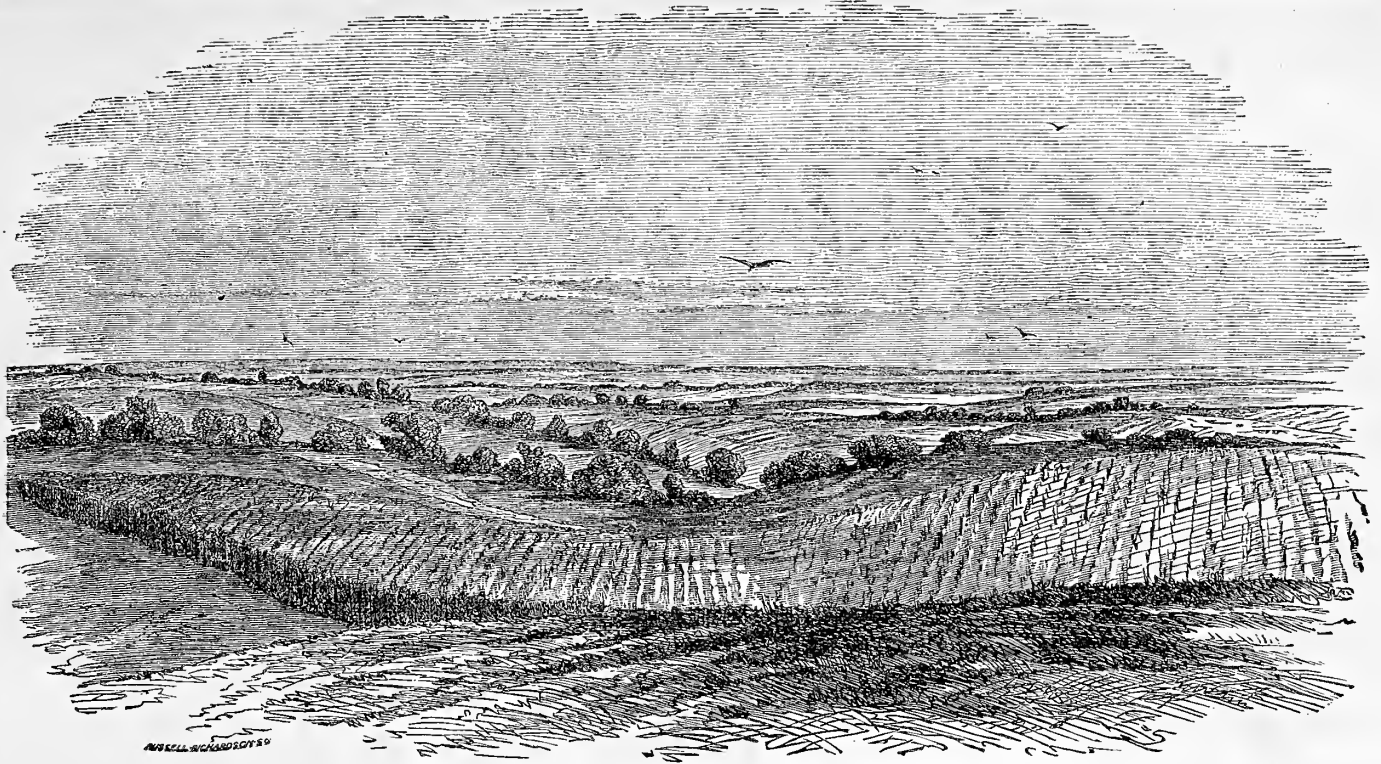

AT CRETE, NEB., LOOKING UP THE BIG BLUE VALLEY.

IF YOU WANT A FARM OR HOME,
 YOU SHOULD BUY OF THE
BURLINGTON AND MISSOURI RIVER RAILROAD CO.
 IN IOWA OR NEBRASKA.

BECAUSE—Their prices are low, ranging for the best land from Three to Ten Dollars per acre.
BECAUSE—No payments are required of the purchaser for four years, except interest at six per cent.
BECAUSE—After the fourth year only one seventh of the principal is payable annually till the whole is paid.
BECAUSE—You are not required to go into a wilderness, these being well-settled States, the population of which is rapidly increasing.
BECAUSE—The mildness of the climate and fertility of the soil is such that the settler can pay for his farm from the products raised upon it long before the time when the principal becomes due.
BECAUSE—Failure of crops from drouth is unknown.
BECAUSE—Large allowances are made upon fare and freight, thus giving low rates on both to purchasers of this Company's lands.

AND YOU SHOULD BUY THIS YEAR.

BECAUSE—Purchasers of our lands in Nebraska during 1874 who cultivate one-half their land within two years from their purchase are allowed a reduction of twenty per cent on its price. **LARGE DISCOUNTS** also, FOR CASH, within One, Two, or Five Years.

Send for Circulars, with full information on all points, to

GEO. S. HARRIS, Land Commissioner,
 At Lincoln, Nebraska, for land in Nebraska. At Burlington, Iowa, for land in Iowa
JAS. R. WOOD, General Agent, 59 Clark St., Chicago, Ill.

Or to **W. D. COWLES**, General Agent, 317 Broadway, New York.



Established 1858.

TRADE MARK PATENTED.

The best and cheapest Paint in the world for Iron, Tin or Wood. For sale by the Trade everywhere. PRINCE'S METALLIC PAINT CO., Manufacturers, 96 Cedar St., New York. **CAUTION**—Purchasers and consumers are cautioned against imitations of our METALLIC PAINT. All genuine PRINCE'S METALLIC PAINT will bear our name and trade mark on each and every package. Send for a circular.

PAINT

YOUR HOUSE WITH THE NEW YORK ENAMEL PAINT AND SAVE 50 PER CENT.

White, Black, and all the other Shades, mixed ready for use. Send for Sample Cards and Price-List. **N. Y. Enamel Paint Co., 43 Chambers St., N. Y.**



BUILDING FELT.

This water-proof material, resembling fine leather, is for outside work (no tar substances used) and inside, instead of plaster. Felt carpetings, etc. Send two 3-cent stamps for circular and samples.

C. J. FAY, Camden, N. J.

ADVERTISERS should send to **GEO. P. ROWELL & Co.**, 41 Park Row, N. Y., for their *Eighty-page Pamphlet*, containing lists of 3,000 newspapers and estimates, showing the cost of advertising. Mailed free to all applicants.

Lake Superior and Mississippi R.R.

SAINT PAUL, June, 1874.

This Company has for sale large tracts of Land, in the vicinity of its Railroad, on which are extensive wild Cranberry Marshes, from which several Thousand Bushels were gathered in 1873. To any person acquainted with the culture of Cranberries, rare opportunities are offered. Address

JNO. P. ILSLEY,
 PRESIDENT AND LAND COMMISSIONER.

THE PENN MUTUAL LIFE INSURANCE COMPANY OF PHILADELPHIA.

ASSETS ACCUMULATED, \$1,127,996.96.

The Penn is a purely mutual Company. All of its surplus premiums are returned to the members every year. Dividends may be applied to reduce the premium or increase insurance as desired. **SAML. C. HUEY**, Pres.—General and Local Agents wanted in the Middle and Western States. Apply to **H. S. STEPHENS**, Vice Pres., No. 921 Chestnut Street, Philadelphia, Pa.

NIAGARA FIRE INSURANCE COMPANY,
 201 Broadway, N. Y.

Capital Stock.....\$500,000
 Cash value of Assets.....\$1,308,224
 Total Liabilities.....82,302

Net Assets.....\$1,225,922
 Dwellings and Farm Risks a specialty at all our Agencies.
HENRY A. HOWE, President.
P. NOTMAN, V. P. and Sec'y.

"EDEOGRAPHY." A new book on the art of Writing by Sound; a complete system of Phonetic Short Hand—the shortest, most simple, easy, and comprehensive, enabling any one, in a short time, to report trials, speeches, sermons, &c. The Lord's Prayer is written with forty-nine strokes of the pen, and 140 words per minute. The unemployed should learn this art. Price, by mail, 50 Cts. Agents wanted. Address **T. W. EVANS & CO.**, 139 S. Seventh Street, Phila., Pa.

How to Make a Dollar or Two. Mornings and Evening—near home—with "GOOD BOOKS FOR ALL." Send stamp for facts to **S. R. WELLS**, 389 Broadway, New York.



Every Farmer,
 Every Breeder,
 Every Horse-Owner
 His Own Farrier.
 Send for circulars to
GOODENOUGH HORSE-SHOE,
 Box 3,044, P. O., N. Y.
 Offices: 34 and 36
 Elizabeth Street.

Tongue-Lolling Bits.

We make Bits to prevent the above bad habit. \$2, \$3, or \$4, for cash with order, or C. O. D. Hand-forged Bits made in any style to order. Patentes of the **BALDWIN BIT**, for side pullers and hard mouths. \$2, \$3, and \$4. Also agents for the **MARTIN BIT**. See adv. in "Turf, Field, and Farm," and "Wilkes' Spirit of the Times."
JOS. BALDWIN & CO., Newark, N. J.

New York College of Veterinary Surgeons, INCORPORATED 1857.

Lectures for 1874 will commence about the middle of October and continue until the last of February, 1875. Fees: Matriculation, \$5; Faculty, \$120; Graduation, \$25; Dissecting, \$5; Address for Circulars, **A. F. LIAUTARD, V.S., M.D.**, Sec'y, 205 Lexington Ave., New York.

\$290 Piano. Circulars free. U. S. Piano Co. 810 B'dway, N. Y.

**HAKES' IMPROVED
SWIVEL PLOWS,
For Level Land and Side Hill,**

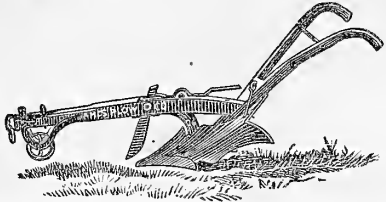

Overcome all objections in Swivel Plows heretofore made for plowing level land, and the same results are obtained as with hand-side plows.

Possess a combination of advantages which recommend them to universal use, effecting the complete inversion and pulverization of the soil on level as well as uneven surfaces, avoiding dead furrows and side ridges, giving an even surface to the fields.

The merits of these Plows are fully stated in our illustrated and descriptive circular, which will be sent by mail, free, to any address. Made only by

AMES PLOW COMPANY,
53 Beekman St., New York,
and Quincy Hall, Boston, Mass.

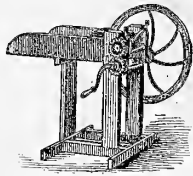

**The Copper-Strip
FEED CUTTER,**
As made by us, is the BEST.
Agents Wanted. Send for Circular.
Cider Mills and Presses
in great variety.
Improved Corn Shellers.
THE NEW YORK PLOW CO.,
53 Beekman-st., New York.

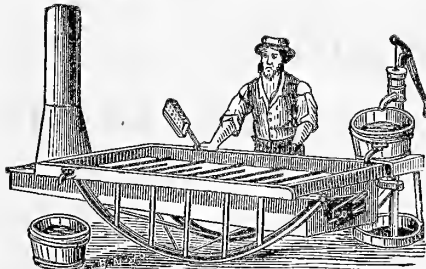

THE ONLY RECOGNIZED STANDARDS in CANE MACHINERY are the

Cook Evaporator and
the **Victor Cane Mill.**

18,000 COOK EVAPORATORS are in use, and 13,000 VICTOR CANE MILLS, all warranted. They have taken the FIRST PREMIUM AT 117 STATE FAIRS. All attempts, thus far, to equal these unrivaled machines by other contrivances, have signally failed on trial. Planters can't afford to risk crops of Cane on light, weak, unfinished Mills that break or choke, or on common pans or kettles that do second-class work, and only half enough at that. The *Savory Hand-Book and Price-List Sent Free.* BLYMYER MANUFACTURING CO., 661 to 694 West Eighth St., Cincinnati, O., Manufacturers of Cane Machinery, Steam-Engines, Shaker Thresher, Wood-Sawing Machines, Corn and Cob Crushers, Farm, School, and Church Bells.

**EUREKA
CORN
HUSKER.**

SELLS 'AT SIGHT.
Does Two Men's Work.
No sore or cold fingers.—Best Cast-steel.—Last a Lifetime.—Taken 6 Premiums.—Every Farmer wants them.—Will send 2 Samples, post-paid, for 60 cents—or 4 Styles for \$1.00. Agents wanted.
PLUMB & CO.,
108 South 8th St., Philadelphia, Pa.

ADDRESS FOR PRICE-LIST, AND DESCRIPTION, SEND FOR CIRCULAR, TO
PK. DEERICK & CO
SALES HAY WITHOUT TRAMPING OR STOPPING.
THE P.K. DEERICK PERPETUAL BALING PRESS

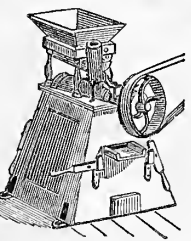
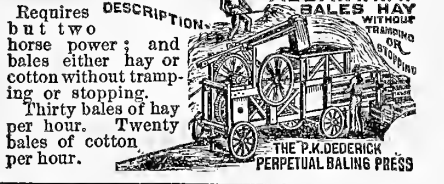

**PREMIUM FARM
GRIST MILL.**
Is simple, cheap and durable, and grinds all kinds of grain rapidly. It is adapted to all kinds of horse powers.
Also Union Railway Horse Powers, requiring a very low elevation and yet giving more power than others. Also every variety of approved implements. SEND FOR DESCRIPTIVE CIRCULAR.
W. L. BOYER & BRO.,
Philadelphia, Pa.

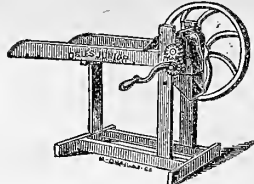

I have invented the cheapest and best hay, straw, and stalk cutters in America. Do not pay until you have tried it on your farm and like it. Local Agents wanted. Splendid chance for farmers. Circulars free.
WARREN GALE,
Chicopee Falls, Mass.

**CADY'S PATENT
IRON SLEIGH KNEES**

Have been tested thoroughly the past five years, and are in use in almost every Northern State; we have yet to hear of the first instance wherein they have failed to give entire satisfaction. The increasing demand wherever they have been introduced, has demonstrated beyond question that they are no longer an experiment, but must and are superseding Wooden Knees for the following reasons:



ARE CHEAPER, MORE DURABLE,
NO JOINTS TO DECAY.

WILL CARRY DOUBLE THE
LOAD OF A WOODEN KNEE.

The Wooden runners and beam relieve the Iron Knee from all concussion or strain that would be liable to break it. The braces underneath are dispensed with, which lessens the draft in Heavy Snows and Crusts. They can be constructed with less mechanical skill, and at one-third less expense than by the old method. In fact, these Knees place Bob Sleds within the reach of all.

See illustration and description in *American Agriculturist* January, 1874, page 16.
WARRANTED AS REPRESENTED.
Send for Descriptive Circular and Price-List.
BRADLEY MANUFACTURING CO.,
Syracuse, N. Y.

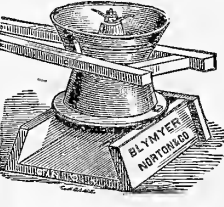

"Every Farmer and Stock-Feeder should have one."
**LITTLE GIANT
CORN AND COB MILL.**
Hedge's Improved
CORN AND COB MILLS.
Horse or Steam Power.

**CIRCULAR AND CROSS-CUT WOOD
SAWING MACHINES.**

Circulars and Price-List sent free.
BLYMYER MANUFACTURING CO.,
661 to 694 West Eighth St., Cincinnati, O.,
Manufacturers of Cane Machinery, Steam-Engines, Shaker Thresher, Farm, School, and Church Bells.

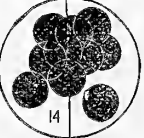

**MAYNARD'S BREECH-LOADING
Combination Rifles and
Shot-Guns.**
CENTRAL FIRE
Reloading-Capped Cartridges. Send for Price-List with *Target Illustrations.*
Mass. Arms Co., Chicopee Falls.

\$100 to \$200 per month guaranteed to agents everywhere, to sell our **Indestructible White Wire Clothes Lines.** Sample free. Address the **Hudson Wire Mills,** 128 Malden Lane, N. Y., or 18 Clark St., Chicago, Ill.

FIRST Premiums awarded by Amer. Inst., 1870.
MICROSCOPES.
Illustrated Price-List sent free on application.
MAGIC LANTERNS.
Catalogue, priced and illustrated, sent free.
T. H. McALLISTER, Optician, 49 Nassau-st., N. Y.

Wm. Gillott
STEEL PENS!
Sold by all Dealers.
No. 91 JOHN ST., NEW YORK.
HENRY HOE, Sole Agent. JOSEPH GILLOTT & SONS.

**Hope
Seat
Springs.**

For Farm Wagons, Trucks, and Carriage. The best and Easiest Riding Spring ever invented. The seat can be moved to any part of the wagon, or can be removed at will. The spring is entirely under the seat, and out of the way. Every spring fully warranted. After using them six months, if not found as represented, can be returned, and money will be refunded. Every Farmer should have a pair. Agents wanted. Send for circular.
B. F. WELLS, Sole Agent, 47 Dey St., New York.



**A
M
A
C
R
I.**



**P
A
T
E
N
T
D
E
P
T.**

IMPORTANT TO INVENTORS.
**American Agriculturist
PATENT DEPARTMENT**

In compliance with the request of numerous inventors, we have organized a

PATENT DEPARTMENT

in connection with this office for the transaction of all business connected with

Securing Patents

in the United States and foreign countries.

Reliability

which has been maintained by the AMERICAN AGRICULTURIST for more than thirty years will be carefully guarded in this as in other departments.

All Inventors

desirous of procuring patents at moderate cost are invited to forward (express prepaid) a model of their invention, with a brief description of its working. The model should not exceed one cubic foot in dimension. Upon receipt of model an opinion as to patentability will be given free of charge.

Preliminary Examination

at the Patent Office, to determine patentability, will be promptly made for a fee of \$5.

Litigation of Patents.

The services of the best counsel have been secured to prosecute or protect before the U. S. Courts and the Patent Office the claims of those intrusting their business to this agency. Specifications, drawings, engravings, models, and all other appliances furnished at moderate prices.

In all dealings with this Department inventors may depend upon promptness, fidelity to their interests, and the best services which can be rendered by thorough experts. For full particulars, address

**AMERICAN AGRICULTURIST
PATENT DEPARTMENT
ORANGE JUDD COMPANY,
245 Broadway, New York.**

STANDARD WORKS ON HORSES.

Sent post-paid on receipt of price.

- Cole, S. W.** The American Veterinarian. 12mo.....\$ 75
 - Dadd, Geo. H.** The Modern Horse-Doctor; containing Practical Observations on the Causes, Nature, and Treatment of Disease and Lameness in Horses. 12mo..... 1 50
 - De Huys, Chas.** The Percheron Horse. 12mo. Illustrated..... 1 00
 - Dwyer, Francis.** On Seats and Saddles, Bits and Bitting, and the Prevention and Cure of Restiveness in Horses. 12mo. Illustrated..... 2 00
 - Frank Forester's Horse and Horsemanship** of the United States and British Provinces of North America. By Henry William Herbert. In two superb royal octavo volumes of 1,200 pages, with steel engraved original portraits of thirty celebrated representative Horses. This Standard Historical Work has been thoroughly revised, newly written, compiled, and perfected to the present time. By S. D. & B. G. Bruce, Editors of the *Turf, Field, and Farm*. Price, post-paid..... 10 00
 - Herbert, H. W. (Frank Forester).** Hints to Horse-Keepers. A Complete Manual for Horsemen; embracing how to Breed, Buy, Break, Use, Feed, Physic Horses, etc. Illustrated. 12mo..... 1 75
 - Jennings, R.** Horse-Training made Easy. Being a New and Practical System of Teaching and Educating the Horse. 16mo..... 1 25
 - Jennings, R.** The Horse and his Diseases; embracing his History and Varieties, Breeding, etc. Illustrated. 12mo..... 1 75
 - McClure, R.** The Gentleman's Stable Guide. Familiar Descriptions of the Am. Stable; most approved Method of Feeding, Grooming, and General Management of Horses. 12mo..... 1 50
 - Mayhew, E.** The Illustrated Horse Management. Descriptive Remarks on Anatomy, Medicine, Shoeing, Food, etc. Illustrated. 8vo 3 00
 - Mayhew, E.** The Illustrated Horse Doctor. Being an Accurate and Detailed Account, accompanied by more than 400 Pictorial Representations, of the various Diseases to which the Horse is subject. 8vo..... 3 00
 - Miles on the Horse's Foot**..... 75
 - Murray, Rev. W. H. H.** The Perfect Horse..... 4 00
 - Rational Horse-Shoeing**..... 1 00
 - Riley, H.** The Mule. A Treatise on the Breeding, Training, and Uses to which he may be put. 12mo. Cloth..... 1 50
 - Simpson, J. C.** Horse Portraiture; embracing Breeding, Rearing, and Training Trotters, their Management on Track, Preparation for Races, etc., etc. With an Appendix containing the performances of Dexter, and a Portrait... 3 00
 - Stewart, John.** The Stable Book. A Treatise on Management of Horses, in relation to Stabling, Feeding, Grooming, Watering, and Working; Construction of Stables, etc., etc. 12mo. Illustrated..... 1 50
 - Stonehenge on the Horse in the Stable and the Field.** By J. H. Walsh (Stonehenge). Illustrated. 170 engravings. 8vo. Cloth..... 3 50
 - Veterinary Homeopathic Practice**..... 5 00
 - Wallace, J. H.** American Stud-Book. Vol. 1. Being a Compilation of the Pedigrees of American and Imported Blood-Horses to 1840.... 10 00
 - Wallace, J. H.** American Trotting Register. Containing Pedigrees of Trotting Horses, and a Record of all Performances, from the earliest dates to the close of 1870; being over 6,000 contests. With Essay on True Origin of the American Trotter, and Rules of Government for trials of speed..... 10 00
 - Walsh, J. H. (Stonehenge).** The Horse in the Stable and the Field, and Management in Health and Disease; with Essay on the American Trotting Horse; Suggestions on Breeding and Training of Trotters. Large 12mo. Illustrated.. 2 50
 - Warne's Handbook on the Horse; Varieties and Management**..... 50
 - Woodruff, Hiram.** The Trotting Horse of America. How to Train and Drive Him. 12mo. Cloth..... 2 25
 - Youatt, W.** On the Structure and Diseases of the Horse, with their Remedies. Brought down by W. C. Spooner. 12mo..... 1 50
- Address **ORANGE JUDD COMPANY,**
245 BROADWAY, NEW YORK.

STANDARD WORKS ON Cattle, Sheep, and the Dog.

Sent post-paid on receipt of price.

- Allen, R. L.** Domestic Animals. History and Description of the Horse, Mule, Cattle, Sheep, Swine, Poultry, and Farm Dogs. With Directions for their Management, Breeding, etc. 12mo.....\$ 1 00
 - Allen, L. F.** American Cattle. Their History, Breeding, and Management. Illustrated. 12mo..... 2 50
 - Dadd, J. H.** The American Cattle Doctor. Containing the Necessary Information for Curing the Diseases of Oxen, Cows, Sheep, etc. 12mo..... 1 50
 - Darwin, Charles.** The Variation of Animals and Plants under Domestication. Illustrated. 2 vols. 12mo..... 6 00
 - Flint, Chas. L.** Milch Cows and Dairy Farming..... 2 50
 - Guenon, M. F.** A Treatise on Milch Cows, whereby the Quality and Quantity of Milk any Cow will give may be accurately determined by observing natural marks and external indications alone, etc. 8vo. Cloth..... 75
 - Harris, Joseph.** A Treatise on the Pig. Breeding, Rearing, Management, and Improvement. Illustrated..... 1 50
 - Jacques.** The Barn-Yard. A Manual of Cattle, Horse, and Sheep Husbandry; or, How to Breed and Rear Domesticated Animals. 12mo... 1 00
 - Jennings, R.** Sheep, Swine, and Poultry. The Best Modes of Breeding, their Feeding, Management, etc. Illustrated. 12mo. Cloth.... 1 75
 - Jennings, R.** Cattle and their Diseases. Embracing their History and Breeds, Crossing and Breeding, Feeding and Management..... 1 75
 - Morrell, L. A.** The American Shepherd. Being a History of the Sheep; with their Breeds, Management, and Diseases. 12mo..... 1 75
 - Randall, H. S.** Fine Wool Sheep Husbandry. 12mo..... 1 00
 - Randall, H. S.** Sheep Husbandry. With an Account of the Different Breeds, and Directions in regard to Summer and Winter Management..... 1 50
 - Randall, H. S.** The Practical Shepherd. A Complete Treatise on the Breeding, Management, and Diseases of Sheep. 8vo..... 2 00
 - Youatt, W., and W. C. L. Martin.** Cattle. Being a Treatise on their Breeds, Management, and Diseases. Illustrated. 12mo..... 1 50
 - Youatt, W., and W. C. L. Martin.** The Hog. A Treatise on the Breeds, Management, Feeding, and Medical Treatment of Swine, etc..... 1 00
 - Youatt, W.** Sheep. Their Breeds, Management, and Diseases. To which are added Remarks on the Management of Sheep in the United States..... 1 00
- Address **ORANGE JUDD COMPANY,**
245 BROADWAY, NEW YORK.

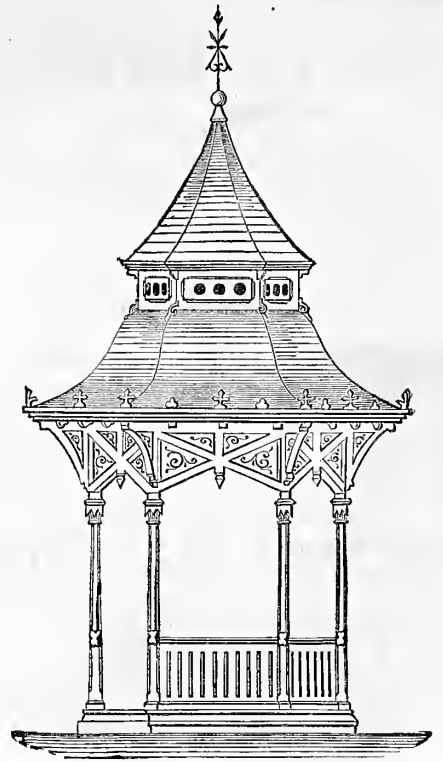

A Practical Book, one that Architects, Builders, and Carpenters can not afford to be without, entitled

DETAIL, COTTAGE, AND CONSTRUCTIVE ARCHITECTURE,

Containing 76 FULL PLATES, 20 plates more than before offered in a similar work for Ten Dollars.

Published under the direction of A. J. BICKNELL. Showing a great variety of Designs for Cornices, Brackets, Windows and Window Caps, Doors, Piazzas, Porches, Bay and Dormer Windows, Observatories, Towers, Chimney Tops, Balconies, Canopies, Scrolls, Gable and Sawed Ornaments, Fences, Stairs, Newels, Architraves, Mantels, Plaster Finish, etc., etc.; including Forty-five Perspectives, Elevations and Plans of Modern Designs for Cottages with Details, and Eighteen Elevations of Summer Houses, Villas, Seaside Cottages, and Country Houses, together with Fourteen Designs for Street and Store Fronts, with Inside Finish for Stores and Banks; also, Framing for Dwellings, Barns, Exhibition Buildings, Roofs, Bridges, etc., etc., making in all a Practical Book for Architects, Builders, Carpenters, and all who contemplate Building or Remodeling Wood, Stone, or Brick Buildings. One Large Quarto Volume, sent Free by Mail or Express, on receipt of Price.....\$10.00.

CARPENTERS' and BUILDERS' ASSISTANT,

And Wood Workers' Guide,

By L. D. GOULD, Architect and Practical Builder.

Containing 23 Plates, fully described; also, tables of the strength of materials; technical terms used by carpenters, etc., etc. This work is intended to combine all the knowledge the workman requires to construct any design in carpentry, by a new and easy system of lines, reducing the science of construction to an agreeable and pleasant occupation, rather than an unpleasant task. One 8vo. volume, bound in cloth. Price.....\$3.00.

ARCHITECTURE.

By CUMMINGS & MILLER.

A Practical Book on Architectural Details; containing over One Thousand Designs and Illustrations, showing the manner of constructing Cornices, Doorways, Porches, Windows, Verandas, Railings, French Roofs, Observatories, Piazzas, Bay-Windows, Cut-Stone Work, various styles of Modern Finish, and Street Fronts of Houses, Stores, etc., etc. One Large Quarto Volume. Price, post-paid....\$10.00.

Loth's Practical Stair-BUILDER.

A complete Treatise on the Art of Building Stairs and Hand-Rails. Designed for Carpenters, Builders, and Stair-Builders. Illustrated with Thirty Original Plates. By C. EDWARD LOTH, Professional Stair-Builders. One Large Quarto Volume. Bound in Cloth. Price.....\$10.00.

Address

ORANGE JUDD COMPANY,

245 BROADWAY, NEW YORK.

GREAT DEDUCTION. TEAS and COFFEES

At Wholesale Prices.
Increased Facilities to Club Organizers.
Send for New Price-List.
THE GREAT AMERICAN TEA COMPANY,
(P. O. Box 5643.) 31 and 33 Vesey St., New York.

WOOD, TABER & MORSE,
Eaton, Madison Co., N. Y.

MANUFACTURERS OF

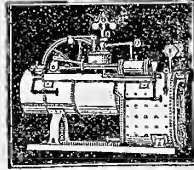

Steam-Engines,
Portable, Stationary, and
Agricultural.
Hundreds in use in Shops, Print-
ing Rooms, Mills, Mines, and on
Farms and Plantations for Grain
Threshing, Food Cooking for
Stock, Cotton Ginning, Sawing, etc.
Circulars sent on application.

HARNESS, BLANKETS,



**HORSE CLOTHING, and HORSE FURNISH-
ING GOODS** of every description.
Style and grade at prices that please everybody.
**ELEGANT NEW STYLES FOR THIS
FALL AND WINTER.**
C. M. MOSEMAN & BRO.,
Manufacturers, 114 Chambers St., N. Y.
Send for Illustrated Price-List.

THE FRUIT RECORDER AND COTTAGE GARDENER

**3 MONTHS
FREE.**

will be sent FREE for 3 months to
all who will pay postage at office
of delivery. We do not ask any
one to subscribe for our paper un-
til they know what they are to get.
It speaks for itself. Price only \$1
per year. Our **Small Fruit
Instructor** is a work of 64 pp.
that tells in simple language just
how to grow fruits in abundance
for home use or market. Price 25 cts., post-paid.
A. M. PURDY, Palmyra, N. Y.

Herald of Health.

This monthly is devoted to the culture of the body and
mind; to rearing healthy and beautiful children; to the re-
covery of health without drugs; to the improvement of the
physique; and to showing people how to live so as to be
healthy, happy, and make the most of life. The Scientific
American says: "It contains more sensible articles than
any monthly that comes to our sanctum." \$2.00 a year, with
a premium of the complete works of Shakespeare, in one
volume of over 1,000 pages and 36 illustrations.
WOOD & HOLBROOK, 13 and 15 Light St., New York.

Patent Chemical Metallic Paints,
GROUND IN OIL and MIXED, ready for use, in
cans, kegs, and barrels.
50 cts., \$1, and \$1.50 per gallon.
Also Liquid Slate and English Roof Paints,
ground in oil, 50 cts. to \$1.00 per gallon.
N. Y. CITY OIL CO., Sole Agents, 116 Maiden Lane, N. Y.
Send for Cards of Colors and Testimonials.

GENUINE Peruvian Guano.

In Large or Small Quantities.
Circular, containing testimonials, references, and full par-
ticulars, mailed free on application to
R. BALCAZAR,
P. O. Box 120. No. 53 Beaver Street, New York.

SOMETHING NEW in relation to Boys'
Boarding School. 8th year. *No extras.* All books fur-
nished free to scholars. Catalogues free. Address
HIRAM H. POST, Prin., Sing Sing, N. Y.

Waltham Watches.

HOWARD & CO., No. 222 Fifth Avenue, New York,
continue to send single Waltham Watches by Express or
Mail to any part of the Country, no matter how remote,
without any risk to the purchaser. Having sold Waltham
Watches on this plan for the last six years, their customers
are numbered by thousands, and from almost every county
in the Union. In every case the purchaser gets a good, re-
liable Watch, and full value for the money. Great improve-
ments have been made during the present year; all grades
and sizes are now made both as key-winders and stem-
winders. Our new price-list which is sent free, describes all
the new Watches with prices of each. Write for it, and
mention that advertisement was seen in the American
Agriculturist. Address,
HOWARD & CO., 222 Fifth Avenue, New York.

THE HOOSIER SCHOOL-MASTER.

By **EDWARD EGGLESTON.**
Finely Illustrated, with 12 Full-Page
Engravings, and Numerous Other
Cuts.

NOTICES BY THE PRESS.

It is full of quaint humor, a tender pathos, and vivid de-
scriptions.—*New York Standard.*
The "events" are stirring and dramatic, and the style is
quiet, impersonal, and almost epigrammatic in its ability to
lay bare an entire situation or character in a sentence or
phrase.—*Brooklyn Daily Eagle.*
It is at once quaint and truthful, and illustrated as it is by
masterly cuts, it should be one of the most popular
books.—*Christian Standard (Cincinnati).*
For realistic conception and life-like delineation of char-
acter, it is not excelled by any American story.—*Methodist.*
Some passages in it, for life-like delineation and the sim-
ple, artless beauty which constitute the highest perfection
of story-writing, are equal to some of the very best passages
in Dickens.—*Belmonte Telescope.*
PRICE, POST-PAID, \$1.25.

The End of the World. A LOVE STORY.

By **EDWARD EGGLESTON,**
Author of "The Hoosier School-Master."

WITH

Thirty-two Fine Illustrations.

NOTICES BY THE PRESS.

The personages who figure in this story are, with one
exception, country people—such men and women as
Wordsworth loved to study. It is not every man, what-
ever may be his talents, that can safely enter this sphere
of literary labor. To be successful in it, he must possess
exceptional qualities; but for those who know how to
find it, here there is gold of the purest, richest kind. In
such a work, however, there is no convenient place
where mediocrity can rest; there is nothing but absolute
failure or absolute success. And Mr. Eggleston has suc-
ceeded. His power lies in the delineation of character.
The plot is ingenious and natural, the incidents are man-
aged with great skill, and there are many descriptive
passages of singular force and beauty. But the strongest
impression left on the reader's mind as he closes the
volume is that he has been in the company of very inter-
esting men and women, and has made a number of new
and valuable acquaintances.—*The Albion, New York.*
Price, Post-paid, \$1.50.

Agricultural Chemical Analysis.

After E. Wolf, Fresenius, Krocker, and Others.

Edited by **G. C. CALDWELL,**
OF CORNELL UNIVERSITY.

PRICE, POST-PAID, \$2.00.

In this work Professor Caldwell has brought together the
processes of analysis which apply especially to soils, fertil-
izers, animals and plants, and their products. He has tested
the methods of the best foreign authorities, and presented
them in a compact hand-book. Such a work has long been
needed by all who teach agricultural chemistry, and by
analytical chemists generally. Professor Caldwell modestly
calls himself the editor, but his book shows that he has not
contented himself with editing the works of others, but has
given much of his own experience.

Either of the above books sent post-paid on receipt of
price, by

ORANGE JUDD COMPANY,
245 BROADWAY, NEW YORK.

JOHN ANDROSS.

BY
REBECCA HARDING DAVIS,
Author of "Life in the Iron Mills," "Dallas Gal-
braith," etc., etc.

ILLUSTRATED.

NOTICES BY THE PRESS.

The story is of intense interest, and holds the reader from
its commencement to its close, and gives much food for
thought regarding the workings of political rings and gov-
ernment frauds in our large cities.—*Post, Salem, Mass.*
The characters and their work are strongly but no doubt
truthfully drawn. Aside from its literary merit, the book
deserves credit for calling attention to a crying shame of
our time.—*Christian Advocate, Pittsburgh, Pa.*
It will at once enchain the attention of the reader, and
prove vigorously and skillfully written, by this among
the foremost novel writers of America.—*Commonwealth,*
Boston, Mass.
Of a story of Mrs. Davis it is hardly necessary to say that
it holds the reader's absorbed attention from beginning to
end. Though the interest of the plot is very considerable,
it is subordinate to the higher interest of the description
and development of character. There is a great deal of
very life-like painting of people and manners.—*Christian
Union, New York.*
The characters are well drawn, the incidents are full of
interest, and the plot sustained with consistency and power.
—*Daily Spy, Worcester, Mass.*
We are constantly struck with the out-cropping of the
one golden thread that holds all her writings together, and
never fails to shine through the web of whatever plot she
weaves about it—that singleness of point and moral more
characteristic of her writings than of any other we know of,
and which is, broadly stated, a self-sacrificing devotion to
duty.—*Daily Standard, Bridgeport, Ct.*
Her hero is a man entangled by the great Ring of Penn-
sylvania, who is sent by this corporation to the State Senate
with a hold of criminality to keep him in hand, who even
then attempts to break loose and join the party of honesty,
but is at the crisis brought in check again by the Ring, with
the still more potent motive of love. . . . The plot is very
well wrought, and the denouement is powerfully couched
and managed.—*New York Evening Mail.*
Price, Post-paid, \$1.50.

PRETTY MRS. GASTON, AND OTHER STORIES.

BY
J. ESTEN COOKE,
Author of "The Virginia Comedians," "Dr. Van Dyke,"
"Surry of Eagle's Nest," etc.

NOTICES BY THE PRESS.

The narrative is ever animated, and here and there touch-
ed with warm, tender, yet natural emotion.—*College
Courant, New Haven, Conn.*
The principal figure of the story, the pretty widow Mrs.
Gaston, is well drawn and attractive, and the author has
displayed in the treatment of this character much care and
ingenuity.—*Boston Traveller.*
The style of Mr. Cooke's writings is smooth and fascinat-
ing, and whoever commences the perusal of them will never
regret the undertaking.—*Westfield News Letter.*
A romance with a most delightful complication of matri-
monial purposes, as well as having a villain, forger, gambler
and detective to assist in the action.—*Boston Post.*
The plot of the principal story is finely wrought out, full
of incident, and there is a sort of fascination about the style,
which claims the attention of the reader until the close.—
Salem Gazette.
A very lively and amusing book.—*Country Gentleman.*
The story is written in popular style—a little plot, a little
mystery, a little love—and is sure to attract a large number
of readers.—*Reading (Pa.) Eagle.*
Price, Post-paid, \$1.50.
Either of the above books sent post-paid on receipt of
price by
ORANGE JUDD COMPANY,
245 BROADWAY, NEW YORK.

WANTED.—The United States Life Insurance Company is now re-organizing its Agency
Department, and is prepared to negotiate with gentlemen of business ability to act as
Agents. Previous connection with the business is not considered necessary.
Apply at the Home Office, 261 Broadway, New York. **JOHN E. DEWITT, President.**

BOOKS for FARMERS and OTHERS.

[Published and for sale by the Orange Judd Company, 245 Broadway, New York. Any of these books will be forwarded by mail, postpaid, on receipt of price.]

Table listing various books for farmers and others, including titles like 'Allen's (L. F.) American Cattle', 'Bailey's Our Own Birds of the United States', and 'Woodward's Cottages and Farm-Houses'.

Table listing books for stock, including titles like 'Youatt and Martin on Cattle', 'O. J. Co. keep in Stock the following Books: Architecture, By Cummings & Miter', and 'Art of Saw Filing, (Holly)'.

FRAMES

FOR THE CHROMOS.

We have made arrangements to supply frames to our subscribers who may desire them for the Chromos which we have distributed. Many will no doubt avail themselves of this opportunity to place these beautiful pictures in handsome frames at moderate cost.

For the Chromo, "UP FOR REPAIRS," Or for the Chromo, "LOOK OUT!"

Table listing prices for frames, including 'Letter A. Neat Black-Walnut Frame, Gilt Band... \$1.15' and 'Letter D. Full Gilt Frame, 2 inches wide... \$1.50'.

For the Chromo, "MISCHIEF BREWING."

Table listing prices for 'Mischief Brewing' frames, including 'No. 1. Neat Black-Walnut Frame, Gilt Band... \$1.15'.

For the Chromo, "THE STRAWBERRY GIRL."

Table listing prices for 'The Strawberry Girl' frames, including 'No. 8. Neat Black-Walnut Frame, Gilt Band... \$1.40'.

Address orders, specifying by its letter or number the frame desired, and inclosing price, as above, to the ORANGE JUDD COMPANY, 245 BROADWAY, NEW YORK.

WHOLESALE PRICE-LIST.

CRANDALL'S IMPROVED BUILDING - BLOCKS FOR CHILDREN



BEAUTIFUL, AMUSING, INSTRUCTIVE. CRANDALL'S Building - Blocks.

PRICE PER DOZEN BOXES. No. 1, \$12.60 (3 Dozen Boxes in a Case). No. 3, \$ 6.00 (6 Dozen Boxes in a Case). No. 4, \$ 6.00 (6 Dozen Boxes in a Case).

CRANDALL'S Masquerade - Blocks.

Price per Dozen Boxes \$6.00 (6 Dozen Boxes in a Case).

CRANDALL'S Expression - Blocks.

Price per Dozen Boxes, \$3.00 (12 Dozen Boxes in a Case).

Crandall's Acrobats.

Price per Dozen Boxes, \$8.00 (6 Dozen Boxes in a Case).

CRANDALL'S Alphabet-Blocks, Red, White, and Blue.

Price per Dozen Boxes, \$6.00 (6 Dozen Boxes in a Case).

Orders from the trade will be supplied on liberal terms.

MANUFACTURED BY C. M. CRANDALL & CO. ORANGE JUDD COMPANY, Sole Agents, 245 BROADWAY, NEW YORK.

CHEAP FARMS AND FREE HOMES

IN THE

Great Platte Valley,

THE GARDEN OF THE WEST.

A LAND GRANT OF

12,000,000 Acres

OF THE

Best Farming, Grazing, and Mineral Lands in America.

THE

Union Pacific Railroad Co.

OFFER FOR SALE

3,000,000 Acres

OF CHOICE

Farming and Grazing Lands

ON THE LINE OF THE ROAD IN THE

STATE OF NEBRASKA.

ON TEN YEARS CREDIT, INTEREST ONLY 6 PER CENT.

Cheaper in Price,

More favorable Terms given, Than can be found Elsewhere.

Convenient to Markets East and West.

NOW IS THE TIME TO SECURE A HOME!!

JUST OUT!

The Second Number of

THE PIONEER,

A handsome ILLUSTRATED PAPER, with Maps, etc., and containing the Homestead Law, also the new TIMBER LAW. Mailed free to all applicants, by addressing

O. F. DAVIS,
Land Commissioner, U. P. R. R. Co.,
OMAHA, NEB.



\$25 A DAY GUARANTEED using our **WELL AUGER AND DRILL** in good territory. HIGHEST TESTIMONIALS FROM GOVERNORS OF IOWA, ARKANSAS AND DAKOTA. Catalogues free. W. GILES, St. Louis, Mo.

Newly Revised and Enlarged Edition.

Practical Floriculture.

A Guide to the Successful Propagation and Cultivation of Florists' Plants.

By **PETER HENDERSON,**
Author of "Gardening for Profit."

Beautifully Illustrated. Price, Post-paid, \$1.50.

In this work, which has everywhere become so deservedly popular, not only is the whole "art and mystery" of propagation explained, but the reader is taught how to plant and grow the plants after they have been propagated. The work is not one for florists and gardeners only, but the amateur's wants are constantly kept in mind, and we have a very complete treatise on the cultivation of flowers under glass, or in the open air, suited to those who grow flowers for pleasure as well as those who make them a matter of trade. The work is characterized by the same radical common sense that marked the author's "Gardening for Profit," and it holds a high place in the estimation of lovers of floriculture. The new edition has been thoroughly revised by the author, and much enlarged by the addition of valuable matter

The following are a few of the subjects embraced in the latest edition:

Laying out Flower Garden and Lawn; Designs for Grounds and for Greenhouses; Soils for Potting; Cold Frames; Hot-Beds; Greenhouses Attached to Dwellings; Modes of Heating; Propagation of Plants by Seeds and by Cuttings; Culture of the Rose and Tuberosé; Growing of Winter-flowering Plants; Construction of Bouquets, Baskets, etc.; Parlor and Window-Gardening; Wardian-Cases and Ferneries; Insects; What Flowers Grow in the Shade; Culture of Grape-Vines under Glass; The Profits of Floriculture; How to Become a Florist, etc., etc.

Window Gardening.

By **HENRY T. WILLIAMS,**

EDITOR OF THE HORTICULTURIST, AND HORTICULTURAL EDITOR OF THE NEW YORK INDEPENDENT.

FINELY ILLUSTRATED.

There can be no more attractive ornaments about the house than beautiful flowers, and Mr. Williams's book tells exactly how they may be arranged, and what flowers to plant. It is seldom that a book is published on such subjects containing so much practical information.

—The World (New York).

CONTENTS:

- | | |
|--|---|
| Chap. 1.—Window Gardening—Its Pleasures—Increase in Popular Taste—Refining Influences. | Chap. 12.—Climbing Vines, Balcony Gardening. |
| Chap. 2.—Location and Design for Window Gardens. | Chap. 13.—Bulbs. |
| Chap. 3.—General Management of Window Gardens. | Chap. 14.—Ferneries, Wardian Cases, Fern Decorations. |
| Chap. 4.—Special Care of Window Gardens. | Chap. 15.—The Caneelia. |
| Chap. 5.—Insects, and how to Kill them. | Chap. 16.—The Rose. |
| Chap. 6.—Propagation from Seeds, Cuttings, etc. | Chap. 17.—The Fuchsia, Myrtle. |
| Chap. 7.—Propagating Boxes, Heating Cases, etc. | Chap. 18.—The Heliotrope. |
| Chap. 8.—Window Pots, Boxes, Plant Stands. | Chap. 19.—The Geranium. |
| Chap. 9.—Conservatories and Greenhouses. | Chap. 20.—The Oleander, Bonvardia. |
| Chap. 10.—Hanging Baskets. | Chap. 21.—Verbenas, Petunias, etc. |
| Chap. 11.—The Ivy for Decorative Purposes. | Chap. 22.—The Mignonette, Cinerarias. |
| | Chap. 23.—Carnations. |
| | Chap. 24.—Alpine Plants. |
| | Chap. 25.—Miscellaneous Plants. |
| | Chap. 26.—Parlor Decorations. |

Price, post-paid, \$1.50

Either of the above books sent post-paid on receipt of price by

ORANGE JUDD COMPANY,
245 BROADWAY, NEW YORK.

CRANDALL'S IMPROVED BUILDING-BLOCKS FOR CHILDREN.

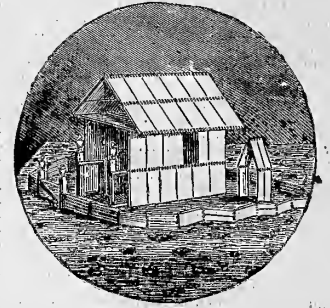

BEAUTIFUL, AMUSING, INSTRUCTIVE.

CRANDALL'S Building-Blocks

Can be made into forms of almost endless variety. The blocks are put up in neat, strong boxes, and a large sheet giving various designs of buildings, etc., accompanies each box.

Price—No. 1, \$2.00; by mail, prepaid, \$2.25.
No. 3, \$1.00; by mail, prepaid, \$1.10.
No. 4, \$1.00; by mail, prepaid, \$1.10.

CRANDALL'S Masquerade-Blocks,

Making 300 different and beautiful Combinations of Pictures, which are in very brilliant colors. They are not injured by washing, do not wear out, and afford endless amusement.

Price \$1.00; by mail, prepaid, \$1.10.

CRANDALL'S Expression-Blocks,

With Letters on one side, Picture on the other. The Alphabet is the key to the picture which, when complete, represents the inventor in Dream Land. These Blocks are water-proof, and can be washed if soiled.

Price 50 Cts.; by mail, prepaid, 60 Cts.

CRANDALL'S Alphabet-Blocks.

Red, White, and Blue.

Tasteless, odorless, and water-proof. The letters are on red, white, and blue ground. All children are pleased with them.

Price 75 Cts.; by mail, prepaid, 85 Cts.

Crandall's Acrobats.

Full of fun and frolic, and most brilliant in costume. These are among the most fascinating and ingenious toys ever invented. The number of figures which can be made with the pieces in a single box is limited only by the ingenuity of the operator.

Price \$1.00; by mail, prepaid, \$1.15.

N.B.—If postage is not remitted with the prices, as above, the blocks will be sent by express at purchaser's expense.

Orders from the trade will be supplied on liberal terms
ORANGE JUDD COMPANY,
245 BROADWAY, NEW YORK.

OCTOBER, 1874.

AMERICAN AGRICULTURIST

FOR THE FARM, GARDEN & HOUSEHOLD.

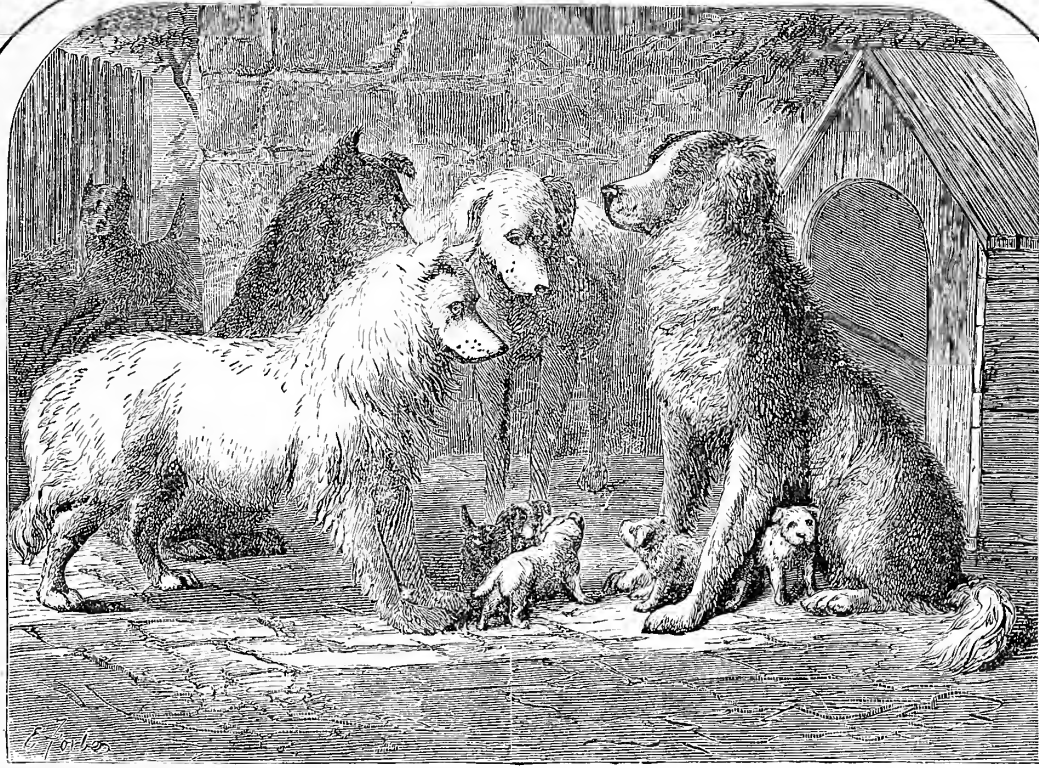

Vol. XXXIII

Number 10

PUBLISHED BY THE
ORANGE JUDD COMPANY,
245 BROADWAY,
NEW-YORK.



REMINGTON

SEWING MACHINES --- FIRE - ARMS --- AGRICULTURAL IMPLEMENTS.



The REMINGTON SEWING MACHINE has sprung rapidly into favor, as possessing the BEST COMBINATION of good qualities, namely: *Light running—smooth—noiseless—rapid—durable—with PERFECT LOCK STITCH.* It is a *Shuttle Machine* with *automatic DROP FEED.* DESIGN BEAUTIFUL, and *construction the very best.*

The Remington Sewing Machine has received premiums at many Fairs throughout the United States, and without effort took the grand MEDAL OF PROGRESS—the highest order of Medal that was awarded at the late VIENNA EXPOSITION.



The REMINGTON WORKS also manufacture the new **Double-Barrelled Breech-Loading Shot-**

E. REMINGTON

Gun, snap and positive action, with *patent joint check*, a marvel of beauty, finish, and cheapness—and the **Celebrated Remington Rifles**—ADOPTED BY NINE DIFFERENT GOVERNMENTS—and renowned throughout the world for Military, Hunting, and Target purposes—ALL KINDS OF PISTOLS; Rifle Canes, METALLIC CARTRIDGES, ETC.

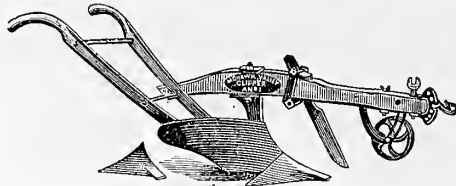

AGRICULTURAL IMPLEMENTS.—Improved MOWING MACHINES, STEEL PLOWS, STEEL HOES, CULTIVATORS, ROAD SCRAPERS, PATENT EXCAVATORS, HAY TEDDERS, COTTON GINS, IRON BRIDGES, ETC.

GOOD AGENTS WANTED.

SEND FOR CIRCULARS.

General Agencies and Depositories Established for the **Remington Family and Manufacturing Sewing Machine.**

- Madison Square, 23d St. New York.
- Western Office of the Company, 237 State St. Chicago, Ill.
- 258 West Jefferson St. Louisville, Ky.
- 332 Washington St. Boston, Mass.
- 181 West 4th Street. Cincinnati, O.
- DeGives Opera House, Marietta St. Atlanta, Ga.
- 406 Main St. Buffalo, N. Y.
- 810 Chestnut St. Philadelphia.
- 617 North Fourth St. St. Louis, Mo.
- Corner North Pearl and Steuben Sts. Albany, N. Y.
- 10 Sixth St. Pittsburgh, Pa.
- New York Office for Arms, 281 & 283 Broadway, New York.

APPLICATIONS FOR AGENCIES constantly received, and should be addressed to our *Principal Office.*

& SONS, Ilion, N. Y.

Oldest, Largest, Best.



EVERY FARMER OR BUSINESS MAN

SHOULD HAVE A

Life or Accident Policy,

Apply to any agent, or write to the Company, at Hartford, Conn.

THE PENN MUTUAL LIFE INSURANCE COMPANY OF PHILADELPHIA.

ASSETS ACCUMULATED, \$4,427,996.96.
The Penn is a purely mutual Company. All of its surplus premiums are returned to the members every year. Dividends may be applied to reduce the premium or increase insurance as desired. **SAM'L C. HUEY, Pres.** General and Local Agents wanted in the Middle and Western States. Apply to H. S. STEPHENS, Vice Pres., No. 921 Chestnut Street, Philadelphia, Pa.

\$3 to \$5 per Day can be made by Farmers' Sons selling our Window Sash Locks. Put our window in one minute. Retails at 10 cts. Address for Descriptive Circular **LIVINGSTON & CO.,** Iron Founders, Pittsburgh, Pa.

ENGLISH CHANNEL

TATTERDEMAILIONS. Only neglect to buy ENGLISH CHANNEL Shoes. If you want a shoe that won't wear ragged on your pretty feet, ladies, insist on buying only these. You can see the channel on the sole.

The Government of Ontario, Canada, having lately established a School of Agriculture, and an Experimental Farm, will receive applications from persons competent to be in charge of the Institution as Principal. The Principal must be thoroughly versed in the practice and science of Agriculture, and possess large personal experience in managing rural affairs. His special charge will be the field department, which he is personally to direct. He is also to devote a daily average of two hours during the year in the class room, to the oral instruction of the pupils in the principles of husbandry, and in such branches of agricultural science, and to such an extent of these branches, as may enable them to understand the scientific facts and principles on which the several field operations are based. It will also be his duty to exercise surveillance over all the operations and transactions of the Institution. Salary, \$2,000, with apartments, fuel and light. Applications, with testimonials, to be addressed to the undersigned, before the 17th October, from whom further particulars may be obtained.

ARCHIBALD McKELLAR,
Commissioner of Agriculture, Ontario.
Toronto, August 24, 1874.

Joseph Gillott
STEEL PENS!
Sold by all Dealers.
No. 91 JOHN ST., NEW YORK.
HENRY HOE, Sole Agent. JOSEPH GILLOTT & SONS,

\$25 A DAY GUARANTEED using our **WELL AUGER & DRILL** in good territory. Endorsed by Governors of IOWA, ARKANSAS & DAKOTA Catalogue free. **W. GILES, St. Louis, Mo.**

INVENTORS Who wish to secure PATENTS should write to **MUNN & CO., 37 Park Row, New York,** for Advice and Pamphlet, 103 pages, FREE.

ADVERTISING RATES.

American Agriculturist.

ENGLISH EDITION.
Inside Pages, \$1.50 per line (agate), each insertion.
Open Pages (open without cutting), \$2 per line.
Last Page, and 2d and 3d Cover Pages—\$2.50 per line.
Page next to Reading and Last Cover Page—\$3.00 per line.
No advertisement inserted for less than \$5.00.

GERMAN EDITION.
Inside Pages, 25 cents per line, each insertion.
Business Notices and Last Page, 40 cents per line.
No advertisement inserted for less than \$1.00.

No Advertisement of Medicines or Humbugs received. Address all orders to **ORANGE JUDD COMPANY,** 245 BROADWAY, NEW YORK.

Gardening for Profit.

A Guide to the Successful Cultivation of the Market and Family Garden.

By **PETER HENDERSON.**

Finely Illustrated. Price, Post-paid, \$1.50.

The following voluntary notice of this book comes from a Western market gardener and shipper of vegetables, and is a specimen of similar testimony from very many quarters. "March 23d, 1874.

"If this should go to Mr. Henderson, I would say that I believe the gardeners of this country would gladly hail another edition of 'Gardening for Profit;' at least, I thank him for that little work. Through its influence I left a paying manufacturing business and began to follow its teachings. This was three years ago. Now I have a market garden of thirty acres and 400 four-foot sash, and enjoy myself as I never did before. Again I thank him."

Money in the Garden.

A VEGETABLE MANUAL,

PREPARED WITH A VIEW TO

ECONOMY AND PROFIT,

By **P. T. QUINN,**

PRACTICAL HORTICULTURIST

In this work the author aims to give, in a plain, practical style, instructions on three distinct although closely connected branches of gardening—the kitchen-garden, market-garden, and field culture; the only and sufficient credentials for the fitness of his undertaking being a successful practical experience for a term of years.

CONTENTS.

- Chapter I. Money in the Garden.
- " II. Hot-beds.
- " III. Artichoke.
- " IV. Beans.
- " V. Cabbages.
- " VI. Egg-Plants.
- " VII. Lettuce.
- Chapter VIII. Melons.
- " IX. Onions.
- " X. Parsley.
- " XI. Radishes.
- " XII. Salsify.
- " XIII. Tomatoes.
- " XIV. Foreign Houses.
- Chapter XV. List of Seeds.

PRICE, POST-PAID - - - - - \$1.50

Either of the above books sent post-paid on receipt of price by

ORANGE JUDD COMPANY,
245 BROADWAY, NEW YORK.

Play and Profit

IN MY GARDEN.

By **E. P. ROE,**

Author of "Barriers Burned Away," etc.

NOTICES BY THE PRESS.

The author takes us to his garden on the rocky hill-sides in the vicinity of West Point and shows us how out of it, after four years' experience, he evoked a profit of \$1,000, and this while carrying on pastoral and literary labors. . . . It is very rare that so much literary taste and skill are mated to so much agricultural experience and practical good sense.—*Harper's Magazine.*

This book is as poetical as it is practical. Still he is no dreamer. He goes into every essential detail with as much minuteness and precision as if he were writing a manual for the practical farmer. Indeed few works professedly devoted to agriculture give more sound and valuable information on the secret of winning golden harvests from the soil than this brief idyllic sketch.—*N. Y. Tribune.*

A very charming book, not only by reason of its pleasant style, but for its quiet refined humor and fund of really useful information on the subject of gardening.—*Boston Gazette.*

It deserves to stand side by side with "My Summer in a Garden."—*Christian Register.*

A fresh, lively work.—*N. Y. Observer.*

One reads without weariness and learns much of practical value.—*Chicago Evening Journal.*

Full of information. Explains just what the reader wishes to know. We most heartily commend it.—*Providence Evening Press.*

A chatty, sensible, profitable book.—*Cleveland Herald.*

The book gives much valuable information, and gives it in the pleasantest manner imaginable.—*Detroit Daily Union.*

Price, Post-paid - - - - - \$1.50

ORANGE JUDD COMPANY,
245 BROADWAY, NEW YORK.

AMERICAN AGRICULTURIST

FOR THE

Farm, Garden, and Household.

"AGRICULTURE IS THE MOST HEALTHFUL, MOST USEFUL, AND MOST NOBLE EMPLOYMENT OF MAN."—WASHINGTON.

ORANGE JUDD COMPANY,
PUBLISHERS AND PROPRIETORS.
Office, 245 BROADWAY.

ESTABLISHED IN 1842.

Published also in German at \$1.50 a Year.

{ \$1.50 PER ANNUM, IN ADVANCE
SINGLE NUMBER, 15 CENTS.
{ 4 Copies for \$5; 10 for \$12; 20 or more, \$1 each

Entered according to Act of Congress, in September, 1874, by the ORANGE JUDD COMPANY, at the Office of the Librarian of Congress, at Washington.

VOLUME XXXIII.—No. 10.

NEW YORK, OCTOBER, 1874.

NEW SERIES—No. 333.

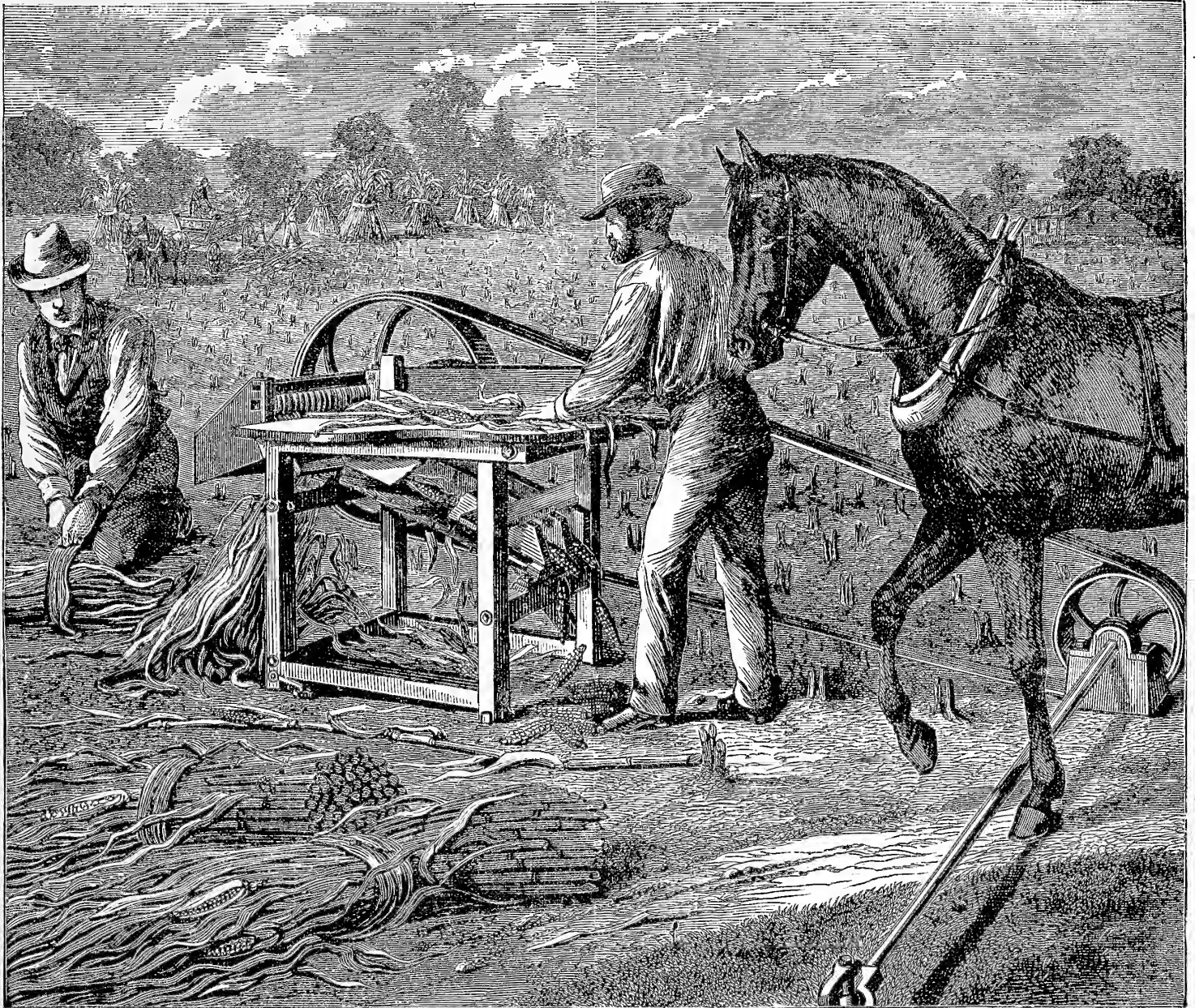

HUSKING CORN BY MACHINERY. — Drawn and Engraved for the American Agriculturist

When we try to realize the enormous bulk of our corn crop, the figures commonly used fail to give us any clear idea of it. In round numbers, a large crop will now reach a thousand million of bushels. This quantity of corn in the ear, would fill a crib of ordinary height and width long enough to reach from New York to San Francisco. Shelled, all this corn would make up 3,000,000 car loads, which would make a train of box-freight cars 17,000 miles in length, or which would extend nearly three-quarters of the distance round the earth at the equator. The idea that all this vast quantity of corn has to be handled ear by ear in the single process of husking alone, presents to our minds a waste of human labor that is surpris-

ing; to say the least, and opens up a field for the exercise of mechanical ingenuity large enough to occupy scores of inventive minds. The general average saving of labor by the use of machinery upon the farm is in a ratio of 10 to 1. That is, with the assistance of machinery, the labor of ten men is done by one man. The mower or reaper, driven by one man, does the work of ten mowers. The thrashing machine, worked by four to eight men, saves labor in about the same proportion. And in almost all the work of the farm we have the help of machinery, except in the harvesting of corn. The greatest need of the time is a corn harvester. A corn-husker we have, but unfortunately it is far too little known and used. From

three or four years' knowledge and study of this machine, we believe it to be at least as valuable a help to the farmer, and as great a labor-saver as the mower or reaper, and were corn-huskers in as general use as the reapers, we should consider them equally indispensable. The usual amount of corn that can be husked by a fair farm hand in a day is from 30 to 40 bushels. We have found few men to husk more than this, although we have heard of those who profess to be able to husk 100 bushels a day. If we take this extreme quantity as the limit of a man's work, then the husking machine that will husk 100 bushels in an hour, will do as much more than hand labor as may reasonably be expected of any farm machinery.

Contents for October, 1874.

Calendar for October.

Antelope, Beisa... 373
Bag Holders... 377
Barn Sheet... 376
Bee Notes for October... 369
Beet, Egyptian... 383
Black Bass, How to Stock Ponds with... 373
Boys and Girls' Columns—Doctor's Talks on Garden Seeds—Aunt Sue's Puzzle-Box—Aunt Sue's Chats—Cruelty to Animals... 388
Brush, Home-Made... 378
California Farm... 378
Catalogues Received... 367
Cistern, Underground... 376
Corn Husker, Philip's Spiral... 370
Corn-Husking by Machinery... 361
Cows, Pasturing in Orchards... 377
Dog-Laws, Enforce the... 375
Egg Inspection... 377
Fairs, Industrial... 368
Fair List... 368
Fair, New England... 368
Farm Work for October... 362
Farming in Ireland, Prize... 379
Fastenings for Barnes... 377
Fertilizers in Gardening, Concentrated... 382
Flower Garden and Lawn in October... 363
Flowers, American Star Thistle... 381
Flowers, Pearly Everlasting... 381
Fruit Garden in October... 363
Greenhouse and Window Plants in October... 363
Hen Lice, Remedies for... 377
Household Department—How to use Corn Husks—Home Topics—Recipes... 386
Ice-House and Cool Chamber... 376
Kitchen Garden in October... 363
Market Reports for October... 363
Notes from the Pines—Here is trouble—Carpeting Beneath Shrubs—Sedum spectabile—Fancy Beds—Ornamental Grasses—Perennial Phloxes—Heath—Glaadioluses... 382, 383
Ogden Farm Papers, No. 56—Butter Making in Ill.—Farming—Education of Farmers—Sheep—Breeding—Milk Churning at the South... 370, 371
Orchard and Nursery in October... 363
Patent Department... 369
Plant, Fine Basket... 384
Plants for Winter, Preparing... 383
Poultry House, Portable... 379
Salt Marshes, Reclaiming... 378
Spring-Houses... 380
Tether, A Safe... 376
Walks and Talks Correspondence... 369
Walks and Talks on the Farm, No. 130—Plowing—Clover Hay—Manure—Pigs... 374, 375
Water in house and Barn... 371
Water Trough for Barn-Yard... 377
Wheat, Drill Sowing... 378
Wheat without Manure... 375
Windows in Horse Stables... 378
Winter Bouquets... 383
Winter Forcing of Lily of the Valley... 384

Calendar for October table with columns for Day of Month, Day of Week, and Moon phases for Boston, N.Y., and Washington.

PHASES OF THE MOON table with columns for Moon, Boston, N.Y., Wash'n, Cha'ston, Chicago.

AMERICAN AGRICULTURIST.

NEW YORK, OCTOBER, 1874.

If there is one admonition that is more timely than another just now, it is to push the fall work ahead. Some kinds of work must be done whatever the weather may be.

Hints about Work.

Winter Wheat.—This crop should be in the ground by this time in the Northern States. In the Middle and Southern States, it may be sown this month.

Corn Husking should be done without delay. Twice as much work may be done on a fine October day, as on a cold blustering day a month later.

should be done by the bushel, and care taken to see that clean work is done, and that the stalks are well bound and shoeked.

Potatoes.—In digging potatoes let them be exposed as little to the sun and air as possible. Dig as soon as tops are dying or dead.

Live Stock generally should now receive more than usual care. Separate unthrifty animals from the rest, and nurse them up before the cold weather comes on.

Weeds.—There is no month in the year while weeds are growing, in which they may not be fought with advantage. Burn everything in the shape of a weed that can be gathered at this season.

Keeping Accounts.—If no accounts have been kept upon the farm, it is a good time now to begin. Make a map of the farm, no matter how rough it may be.

Sundry Matters.—A list should be made of all work that must be done, and that which may be done. Fix a time for doing that which must be done, and stick to it.

Work in the Horticultural Departments.

By the middle of this month, nearly all the harvesting will be finished in the Northern States. There will, however, be plenty of work after harvesting.

INDEX TO "BASKET," OR SHORTER ARTICLES. Ashes, Value of Wood... 366
Baskets, Balloon hanging... 365
Bone Crusher... 366
Boat, How to Build... 367
Brick Machine... 364
Bulls for Breeders... 3
Burlington Co., N. J... 365
Calf, Dysentery in a... 365
Cheese Factories... 365
Chemical Fertilizers... 367
Clover in the South... 367
College of Vet'y Surgeons... 365
Cook Book, Home... 365
Cotswold-Merino Sheep... 365
Crops, Rotation of... 364
Dairy Farm, Situation of... 365
Death of Dr. J. H. Slack... 365
Draining Plow... 364
Eggs, Lining... 367
Farms, Prize... 365
Fruit Samples, Sending... 364
Gold-mina Maid... 365
Grayling... 365
Hedge for New Jersey... 364
Hedgers, Professional... 367
Humbugs, Sundry... 365
Leaf-mold for Wheat... 367
Leaves, Gathering... 365
Limestone Water for Boilers... 367
Liagnolia or not?... 364
Manual of Geology... 364
Manures, Composting... 366
Meadow, Improving... 366
Merino Rams, Value of... 366
Nest Egg, How to make a... 367
Ohio State Fair... 365
Petroleum... 365
Plow Beams, Wrought Iron... 367
Potatoes, Yield of Two... 366
Premium List... 368
Preserving Wood... 367
Sparrows... 365
Stich's Catalogue... 367
Tomatoes for... 367
Western Farmer and Loc. Grower... 364
Wistaria... 364

Rye or Wheat.—"J. N. J." Middletown, Ohio. Upon an inferior soil, rye would be a better crop to sow than wheat.

as they did during the long warm days of August and September.

Orchard and Nursery.

Fruit.—All late sorts should be harvested before sharp frosts. Never shake good fruit from the trees, but pick carefully by hand, to avoid bruises and consequent decay.

Packing.—In packing take care not to injure the fruit, and let it be well assorted; the difference in price between properly assorted fruit, and that packed as it comes from the tree, will repay a good deal of care in this respect. When good prices can be had, it is better to sell at once. Keep the temperature of the fruit cellar as low as possible without freezing.

Cider.—Do not mix that made from the summer apples, with that from the late fruit, unless for making vinegar. Cider made from the late fall and winter apples, is best for home use. The more care used in sorting the fruit, and the more gradual the fermentation, the better the quality will be.

Planting.—Where fall planting is done, set the trees at once, so that they will become well established before cold weather. Land for planting trees next spring should be plowed in the fall.

Labels.—Replace old and defaced labels with new, and at the same time see that a plan is made with the name and place of each tree.

Nursery Trees should be looked after, and if they need cutting back or trimming, do it at once.

Budded Trees will need looking after, and the tyings loosened if too tight.

Pomace.—If it is desirable to separate seeds for raising stocks, small quantities may be washed out by means of a sieve, but where much is needed, a stream of water and a kind of cradle are required.

Peach Stones should be buried in boxes and left over winter. If considerable quantities are planted, the best way is to sow thickly on the ground, and cover with earth, they will crack during winter and are to be sifted out in the spring and planted.

Fruit Garden.

Grapes.—Allow them to become thoroughly ripe before gathering, whether for table use or for wine; when ripe the stems to the bunches lose their stiffness, and hang directly down.

Strawberries may be set out early this month from rooted runners. Muleh old beds with leaves, cut straw, or hay.

Blackberries and Raspberries.—If the fruiting canes were not cut last month, do it at once, and tie up the new wood to stakes or trellises. If new plants are set this fall, cut back to within 3 or 4 inches of the ground. Set raspberries 4 to 6 feet apart, and blackberries 6 to 8 feet.

Currants and Gooseberries.—As soon as the leaves have fallen, prune thoroughly; cut out such old wood as is not needed, and make an open bush. The cuttings may be planted in rows 18 inches to 2 feet apart, and the cuttings 6 inches in the rows. Press the soil firmly around the lower ends of the cuttings. In two years these plants will fruit.

Kitchen Garden.

Cabbages.—Prepare cold-frames for wintering the young plants grown from seed the last month. The frames should be a foot high at the back, and 8 inches in the front, and the width of the length of a common sash, viz., 6 feet. Set out the plants 2 to 3 inches apart each way, putting them down to the leaves; cover in freezing weather, but not before, as the object is to keep them dormant.

Cauliflowers.—Treat in the same way as cabbages.

Celery.—Finish earthing up, banking the earth well up to the stalks, nearly to the top of the leaves. In cold localities it may be stored in trenches the latter part of the month.

Lettuce.—Some of the hardy varieties will winter over in the open ground, if covered with leaves or litter. For early spring use the plants should be set in the cold-frame the same as cabbages.

Rhubarb.—Divide now if new beds are wanted, as the plants start so early in the spring, that they can not then be handled so easily. Give a heavy dressing of good stable manure to old or new beds.

Spinach.—Sow for spring crop early this month. Thin out the late fall crop, and on the approach of freezing weather, give a thin covering of marsh hay.

Squashes.—Cut on the approach of frost, and allow them to lay two or three days in the sun, covering with the vines at night. In handling take care not to bruise or break off the stems, as this will often produce decay. Store in a dry place, where there is no danger of frost.

Sweet Potatoes.—After the first frost has wilted the vines, dig and allow to remain in the sun until dry. Those wanted for winter should be packed in barrels with cut straw, or dry leaves, and stored in a place where the temperature is not below 60°.

Root Crops.—Have the root cellars, bins, barrels, etc., ready for storing as soon as the weather makes it necessary to hurry up the work. Pits in the open ground answer for storing large quantities; the pits should be 2 1/2 to 3 feet deep, 3 feet wide, and as long as needed. Between every two feet of roots, a space of six inches of earth should be left, as this will allow the section to be taken out easily without exposing the rest. Fill the sections with roots to the top of the ground, cover with litter, and on the approach of cold weather, cover with earth, giving slant enough to allow the rain to run off. Of course such pits can only be made in dry ground where water will not settle during the winter.

Plowing and Draining may be done now, as ground thus treated in the fall, will be ready to work some days earlier in the spring.

Manure.—Save everything that can be converted into manure, and collect leaves, leaf-mold, and whatever other absorbents can be had easily. Cart to the field when the teams can be spared, and place in piles where needed.

Flower Garden and Lawn.

If any improvements are designed in the grounds around the house, new walks or drives to be laid out, now is a favorable time to make them, and much better than in spring when the rush and hurry of work is on. If the ground does not lie so that there is a natural drainage, lay underdrains.

House Plants.—Remove to the house at once such plants as it is desirable to save for another season. Cut back both root and branch, and keep in the shade for a few days, until well established. Make cuttings of all such as it is desirable to propagate.

Cannas.—Take up before the frost has killed the foliage, otherwise the roots are apt to rot.

Chrysanthemums.—After the plants have formed good buds, pot for fall and winter blooming. Those left out ought to have stakes to support them.

Perennials.—Where they have been left for three or four years in the same bed, they should be taken up, divided, and reset; they produce enough better flowers to pay for this extra trouble.

Bulbs.—All hardy bulbs, such as tulips, hyacinths, jonquils, crocuses, etc., ought to be put into the ground by the middle of the month if possible. Tender bulbs, like gladioluses, tiger-flowers, etc., should be taken up after frost, dried off, and stored in a cool, dry place, where they will not freeze.

Dahlias.—After the frost has killed the foliage, dig the roots on a warm sunny day, taking care not to break them. As soon as dry, label, and store in a dry cellar.

Protection.—Collect all materials needed for covering half-hardy shrubs and plants. Red cedar, or other evergreen boughs, marsh hay, and leaves, are all useful. Do not cover too early, as the plants may start if protected too soon. Not only are tender plants, but hardy sorts, benefitted by covering.

Greenhouse and Window Plants.

Even though frost has not made its appearance, it is better to have all tender plants under cover, than to expose them to the cool nights. Plants set

out during the summer in pots or tubs, should be taken in, and either repotted, or the top soil removed, and replaced by rich compost.

Repairs should all be finished by this time, and everything put in proper order to receive the plants. See that all insects are destroyed within the house, and all the plants taken into the house, first carefully examined and freed from all vermin.

Commercial Matters—Market Prices.

The following condensed, comprehensive tables, carefully prepared specially for the American Agriculturist, from our daily record during the year, show at a glance the transactions for the month ending Sept. 14th, 1874, and for the corresponding month last year:

Table with 3 main sections: 1. TRANSACTIONS AT THE NEW YORK MARKETS (Receipts and Sales for Flour, Wheat, Corn, Rye, Barley, Oats); 2. Comparison with same period at this time last year; 3. Stock of grain in store at New York (Sept. 8, 1874, and previous months).

Table with 4 main sections: 4. Exports from New York, Jan. 1 to Sept. 10 (Flour, Wheat, Corn, Rye, Barley, Oats, Peas); 5. Receipts at head of tide-water at Albany each season to Aug. 31st (Flour, Wheat, Corn, Rye, Barley, Oats).

Gold has been up to 110 1/4 and down to 109 1/2—closing Sept. 12th at 109 1/2 as against 109 1/2 on August 12th. The movement in domestic produce, of nearly all kinds, has been on an extensive scale. The receipts of Flour and Wheat have been liberal; and, in view of the very favorable results of the harvest in most countries, holders have been very urgent in offering supplies for sale at much lower prices, leading an active trade, in good part for export, the low rates on ocean freights favoring shippers. Corn and Oats, on the contrary, have been offered quite moderately, and have been in very good demand toward the close at much stronger rates. The dealings in Corn have been largely on speculative account, and the market here, as well as in the interior, and at Liverpool, has been measurably under speculative control. Hence, the advance has been somewhat arbitrary. The old crop of Oats had been almost exhausted before the new crop began to reach the market, and as the wants of the jobbing trade were quite pressing, sellers of the new crop were enabled to realize better prices. The transactions in grain, especially in Corn and Oats, have been largely in stock for forward delivery. Rye has been in limited request at our quotations. Barley has been quite nominal in price, no business having been reported thus far this season. Barley Malt has been in moderate request, but at easier figures. Provisions have been fairly active, but quoted lower and unsettled, closing more steadily. Wool has been in brisk demand, mainly on manufacturing account, closing strong and buoyant in price. Cotton has been freely dealt in, mostly for forward delivery, but at easier prices. The later crop reports, having been less favorable, tended to strengthen the views of holders. Tobacco has been unusually quiet, and much firmer; the demand having been largely speculative. Hay and Straw have been quoted lower on a moderate business. Seeds have been in moderate request, but closed weaker in price. Hops have been held with more firmness, on, however, a restricted business. We now quote this year's growth in our comparative table of prices. The crop of domestic now saved is said to be the finest in quality since that of '67. Brewers, it is thought, will not be long adding out that the hops are much richer and heavier than usual, and that a much less quantity will be required to produce the same result. As to the extent of the yield, the prevailing opinion is that we have grown about the same quantity as last year. In the interior, some 3,000 bales have been bought by dealers on speculation, at an average price of 40c. per lb.

CURRENT WHOLESALE PRICES.

Table of current wholesale prices for various commodities including gold, flour, wheat, corn, and other agricultural products, with columns for item names and prices.

unless fat. With many poor on hand, the market has drooped, and prices are off. For fat stock the prices are 6@6 1/2 c.; common to prime, 4 1/2 @ 5 1/2 c. Choice lambs sell for 6 @ 7 1/2 c. Swine.—With increased receipts, the quotations for dressed hogs have given way slightly. Corn-fed hogs have touched 9 1/2 c. during the month. As we close, we note quotations for live at \$7.18 @ 7.31 @ 100 lbs.; dressed hogs at 8 1/2 @ 9 c., and slow of sale for grassers, and 9 1/2 @ 9 1/2 c. for corn-fed.

Don't Fail To Read about the New Campaign On Pages 393 to 396.



containing a great variety of items, including many good hints and suggestions which we throw into smaller type and condensed form, for want of space elsewhere.

Remitting Money: — Checks on New York City Banks or Bankers are best for large sums: make payable to the order of Orange Judd Company. Post-Office Money Orders for \$50 or less, are cheap and safe also. When these are not obtainable, register letters, affixing stamps for postage and registry; put in the money and seal the letter in the presence of the postmaster, and take his receipt for it. Money sent in the above three methods is safe against loss.

N.B.—The New Postage Law.—On account of the new postal law, which requires pre-payment of postage by the publishers, after January 1st, 1875, each subscriber, whose subscription runs over into the next year, must remit, in addition to the regular rates, one cent for each month over which his subscription extends in 1875, or ten cents for the whole year 1875. Every subscriber, whether coming singly, or in clubs at club rates, will be particular to send to this office postage as above, that is, at the rate of ten cents for the year, additional to the regular subscription. Subscribers in British America will continue to send postage as heretofore, for pre-payment here.

Subscribe this month, and get November and December Numbers FREE. Read "Better Yet" on p. 396.

Our Western Office.—Our friends in the West are reminded that we have an office at Lakeside Building, Chicago, Ill., in charge of Mr. W. H. Busbey. Subscriptions to American Agriculturist are taken there, and sample copies of the paper and chromo are delivered, and orders received for advertising on the same terms as in New York. All our books are on sale at the Western Office. Please call and examine, buy, subscribe, and advertise.

What the Publishers Say.—Very interesting reading will be found on pages 393 to 396 of this number. We specially ask all our friends and patrons who have learned by experience the value to themselves and to their homes of this Journal, to kindly call the attention of their friends and neighbors, who are not subscribers, to the column on page 396, headed "Now Save Money." We say, "kindly call attention," because we are sure that any who may be led by such a call to subscribe for this Journal, will be ready to return thanks for the kindness many times before the year 1875 is over, in consequence of the benefit and enjoyment they and their families, from the oldest to the youngest member, will receive from the American Agriculturist.

Magnolia or Not?—"R. E. F.," Pa. The leaves sent are apparently those of some kind of magnolia, but it is not safe to determine a plant from leaves only. That they drop in autumn, is no proof that

the tree is not a magnolia, as all species that are hardy at the North do so. None of the evergreen magnolias would be hardy with you.

Manual of Geology, by James D. Dana, 2nd edition, New York: Ivison, Blakeman, Taylor & Co. In noticing a work by Prof. Dana, the reviewer has only to name the author, and all who know about such matters, will at once understand that the work is as well high perfect as it is possible for one of its kind to be. We rejoice that one of Dana's eminence, can find time and inclination to write text books for popular instruction. A large share of the school-books treating of the natural sciences are made to sell, and when one like Dana or Gray steps into the field, it should be a matter of congratulation. We need only to say in reference to the present work, that it has special reference to American geology, and that the abundant illustrations are mostly from American sources. While it is admirable as a text book, it is also of great value as a work of reference to the farmer and general reader, a matter in which its very full and complete index will prove of great help. It only remains to add that the publishers have worthily done their part, and that type, paper, and engravings, all tend to make a handsome volume.

Sending Fruit Samples.—The same thing has happened this year that has given us trouble in previous years. Persons send us samples of fruit, with no mark on the parcel to show where it came from. After some days a letter will come saying that a pear, a bunch of grapes, or other specimen was sent several days ago, and asking us to give our opinion of it. In the mean time a dozen samples will have accumulated, and we are without the slightest clue to whom they belong. This has happened a number of times this season, and those who have received no reply concerning their pear, grapes, or other fruit, will know that it is because we are entirely unable to identify their specimens. The law does not allow any writing to be sent with the fruit, unless full letter postage is paid, and our friends must take some other method to designate their parcels. We are always ready to name specimens as far as we are able, and hope that friends who send us packages by mail, will send a letter concerning the fruit by the same mail, or before, never after, and request the postmaster to mark the post office upon the bundle or box, in such a manner that it can be read. When boxes are sent by express, the charges should be paid. It is not fair to ask us to pay all the way from 50 cts. to \$2 for the privilege of looking at a fruit, whether good or bad. A few years ago we paid over \$2 on a box, which, when opened, contained only a decayed watermelon. Always prepay.

Brick Machine.—"J. P.," and others. We are unable, at present, to give the address of the maker of the best brick machine. We know of one, at least, that is working steadily making brick, but have not yet been able to ascertain the address of the maker. We believe there is no machine made that will make both brick or tile by changing the dies.

A Draining Plow.—"W. L.," Oberlin, Ohio. There are many varieties of draining or mole plows made, and their use is certainly to be recommended as beneficial. They operate by breaking up the subsoil and leaving a number of more or less effective channels, by which the surface water finds an outlet to the lowest portion of the farm. This, as it goes, is a sort of draining, which is to be practised, rather than none. The mole plow known as the blind ditching plow, made by H. Chamberlin & Son, of Olean, N. Y., will do the work required.

Wistaria.—"H.," Somers' Center, N. Y. You do not say when the leaves of your Wistaria turn yellow. If before their time it may be mildew, or the plant may be in a very wet place, and unhealthy.

Hedge for N. J.—"R.," Pittsgrove, N. J. The best general hedge plant for you, is the Honey Locust. Sow seeds in spring, and when plants are a year old set them in the hedge row.

Rotation of Crops.—"A. B.," Westmoreland Co., Pa. Our present rotation of crops is susceptible of improvement. We have now corn, oats, wheat, and clover, almost universally. There are three grain crops successively, and but one green crop. This helps the land to become foul and weedy, and is too exhaustive. A better rotation in some places, would be to substitute barley for the oats, and to sow clover with the barley, following the clover with wheat. The corn would come between the two small grain crops. This would help to clean the land, as the cleaning crop, corn, would not come next to the green crop, clover. Or

New York Live-Stock Markets.

Table of receipts for live stock markets, including columns for week ending, beefs, cows, calves, sheep, and swine, with total figures.

Beef Cattle.—At the outset the market opened with an improvement of 1/2 c. a lb. upon prime to extra cattle, while poor stock dragged heavily. It was apparent that the influx of poor cattle would result in a lower average, and while extra beefs sold at fully 1/2 c. a lb. higher than at the same time last year, the low range of 5 cents for the poorest weakened the market all round, and prices drooped throughout the month. At the close the market was dull, with a losing business to shippers. To get \$3 a head above first cost in Chicago, was thought to be doing well, and many were sold at prices which paid nothing for freight. At the close extra sold for 13 1/2 c., to dress 58 lbs.; good native steers brought 9 @ 13 c. @ lb., to dress 56 to 57 lbs., and poor Texans and natives sold for 7 @ 9 c., to dress 55 lbs.

The prices for the past five weeks were as follows: Table with columns for week ending, range, large sales, and average.

Milk Cows.—The business in fresh cows has been fair throughout the month. Good average cows would fetch \$55 to \$60, and choice cows, with the calf, sell for \$75. Fancy cows, for family use, sell occasionally for \$80 to \$100. Only choice cows are wanted at this season. Calves.—The market for veals has been firm throughout, grass and buttermilk calves have eased off. Quotations are for good veals, 7 @ 10 c. @ lb.; grassers, \$4.75 @ 10.50 per head, and buttermilk calves at 3 1/2 @ 5 c. @ lb. Sheep and Lambs have been hard to sell,

where it is possible, the wheat might be followed with grass, mixed or not with clover, or the corn might be followed with a crop of roots. Any of these would be better than our present rotation.

Our Premium List.—Do not fail to read the Descriptive List of Premiums to canvassers for the *American Agriculturist*, which will be found on pages 393 to 396. Everybody wants something that will be found there. Look it over carefully, select the thing you want from the useful and valuable articles named, and then go to work and secure it by collecting the necessary number of subscribers, which you can do with but little effort, as thousands have done in past seasons.

Cotswold-Merino Sheep.—"L. R. D.," Washington Co., Pa. The cross-bred sheep produced from Merino ewes and a Cotswold ram, are probably the most useful class of farm-sheep that can be kept, both for early lambs, wool, or mutton. They are becoming a favorite class of sheep in Europe, and we notice that at the Vienna Exhibition of last year, they attracted a great deal of attention, and were considered "fine examples of sheep" by the judges. Specimens from a flock of 340 of these, bred in Moravia, are described as having wool $4\frac{1}{2}$ inches long, 10 months after shearing, much finer than the Cotswold wool, very bright, having good curl, and thickly set upon the skin. The flesh was firmer than that of the Cotswolds, and lambs, 12 to 14 months old weighed 139 to 148 pounds per head. The half-bred animals bred well together without deteriorating.

Balloon Hanging Baskets, Pot-Holders, Etc.—Peter Hendersou & Co. send us an entirely new floricultural appliance, which can be better understood from engravings, than from description. Instead of making a hanging "basket," with a wooden bowl and rattan supports, the harness of the bowl, so to speak,

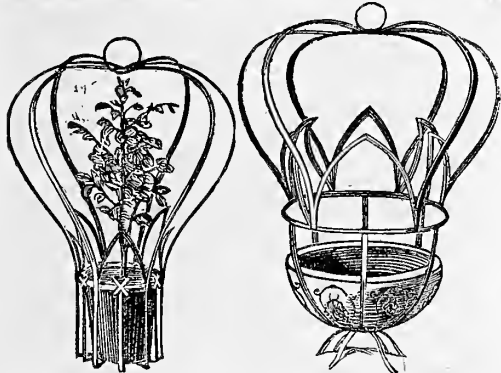

is of narrow steel strips, strong, flexible, and elastic. Some of these are contrived as pot-holders, by which a pot can be suspended in the quickest possible manner. Many plants show much better when seen from below, and this contrivance allows any such specimens to be suspended at the window or elsewhere.

Information as to Cheese Factories.—In an item under this head last month, we inadvertently gave the address of Gardiner B. Weeks, as Utica, N. Y., instead of Syracuse, N. Y. Persons desiring trustworthy information respecting cheese or butter factories, can procure it from Mr. Weeks.

Burlington Co., N. J., is one of the great fruit-producing districts between New York and Philadelphia, and its Annual fair should be in some respects one of the best in the country. We notice that the time of holding the fair at Mt. Holly has been changed from September to October 6 and 7.

Goldsmith Maid.—"Pioneer." Through the kindness of Col. Skinner, of the Turf, Field, and Farm, we are enabled to give you the desired information respecting "Goldsmith Maid." Owner's name, H. N. Smith; age, 17 years; on the course, 9 years; best recorded time, at Rochester, N. Y., August, 1874, 2 min. 14 $\frac{1}{2}$ sec. She did not beat Dexter's time in California last year. Goldsmith Maid has since beaten her own time, as above given, at Mystic Park, Mass., Sept. 3, the mile being made in 2.14.

Gathering Leaves.—"W. C.," Kalamazoo, Mich. We have gathered forest leaves with a steel tooth hay rake, after clearing out all the brush, and cutting off the stumps and snags level with the ground. The rake gathers the leaves up as easily as it does hay into windrows, from which they may be piled into heaps and left until there is leisure time to draw them home. They should be drawn in a hay rack upon which are spread some blankets or barn sheets. The easiest

method of loading them is with barley forks, or large barn baskets made very wide and shallow. Such baskets are made purposely for gathering leaves, for the use of charcoal burners, and are sold in large quantities in Detroit and other lake ports, for shipment to the Northern iron regions. They would be very useful for farmers.

Petroleum.—"G. T. C.," Ancora, N. J. Crude Petroleum is not kerosene. The oil, as it comes from the wells, is what is meant by crude or unrefined petroleum. It is a thick black semi-liquid substance, similar in appearance to the coarsest molasses. This oil has the property of penetrating into the pores of wood rapidly, and hardening and smoothing the surface. When handled, it does not stick to the skin as does linseed oil. For this reason it is preferred for preserving shovel handles, rakes, and all the implements about a farm.

Situation of a Dairy Farm.—"J. A. O.," Grantville, Mass. The richest grass lands are the most suitable for a dairy farm. As these are generally found in what are called bottoms, or level alluvial tracts, such a location should be chosen in preference to less fertile uplands. But where rolling lands productive of excellent grass can be secured, we would prefer such to a river bottom for healthfulness of the stock. A limestone soil is preferable to any other.

College of Veterinary Surgeons.—The session of the College of Veterinary Surgeons of New York, commences on Thursday, the first of October. Information as to fees, etc., can be had from Dr. A. F. Liantard, Secretary, 205 Lexington Ave., New York.

The Home Cook Book is the title of a work made up from the contributions of the ladies of Chicago and other places, published by J. Fred Wagener, and sold for the benefit of "The Home for the Friendless." We have often stated that no one can give a proper opinion of a cook-book, until after thoroughly testing it. A book made up in the manner in which this is, will present a greater variety, than if it were the work of one person, and for the same reason we should expect to find various discrepancies in it, as the views of one contributor differ from those of another as to the method of doing the same thing. We can only say of the present work, that it impresses us favorably, and the lady who presides over our household affairs is of the same opinion. It has the merit of freshness and originality, and we have no doubt will prove itself a favorite household guide. Its mechanical appearance is excellent, and its utility is increased by the binding in of numerous blank leaves, which allows the addition of other recipes under their proper heads. We must, however, ask the editor to leave out in another edition, the medical recipes, some of which, especially for hydrophobia and small pox, are too absurd to be published anywhere.

The Ohio State Fair.—Just as we are closing up these pages, there came to hand copious notes from an associate, who attended the Ohio State Fair, at Columbus. We at this late hour can only record its general success, financially and otherwise. The entries exceeded those of any previous year by over 1000, and thus made a very full and varied exhibition. Live stock, especially cattle and horses, were in large numbers. Cattle from Kentucky and Illinois, as well as from the best herds in Ohio, made a fine show. Sheep, swine, and poultry were much as last year. "Fruit Hall" was well filled, and the fruit of great excellence. The new grounds are regarded as admirable, and the management in general is spoken of in the highest terms.

Death of Doct. J. H. Slack.—This gentleman at the time of his death (Aug. 27) was one of the Fish Commissioners of New Jersey. He was well known by his writings on fish culture, and by his successful fish-breeding establishment at Bloomsburg, N. J. His last public service was to hatch a quantity of the eggs of the California salmon, and distribute the young fry in the waters of the Southern and Middle States. He was a remarkably versatile, and at the same time a very modest man, and his death at the early age of 38 is a public loss.

"English" Sparrows.—"S. F.," Rock Grove, Ill. These sparrows are not exclusive English, as they abound on the continent. They are to be had of the bird dealers in early spring at \$2, more or less, the pair, according to the demand. They have done good service in cities in freeing trees and gardens of insects, but we should hesitate about introducing them into a grain-growing neighborhood. Better protect and encourage the native insect-eating birds. The sparrows do not migrate, hence they must be provided with food in winter when snow is on the ground.

See Pages 393 to 396.

Prize Farms.—It is a part of the regular business of the English Agricultural Associations to offer premiums, frequently of \$500 in amount, for the best cultivated farms. Generally there are three premiums offered for the first, second, and third best of the farms entered for competition. In some parts of Germany, in addition to the award of prizes to the best managed farms, the worst cultivated farms are sought out, and the students of the agricultural schools are given the opportunity of comparing the worst and best managed farms together. This is a most valuable aid in their education. We commend the idea of awarding premiums to the best cultivated farms of certain districts, to the State Agricultural Societies, believing this would result in great good. The prize farms might not be visited by a large number of farmers from a distance, but the agricultural journals would take pains to make known in the widest manner, everything of interest connected with them.

The Grayling.—A correspondent at Adrian, Mich., writes: "I notice your article upon the Grayling in the *Agriculturist* for this month. This fish is found on the west side of this State, (that is the lower peninsula,) from the Manistee river northward to the Straits of Mackinaw, and thence in several of the streams on the northeast coast. My son, who lives near the Boardman river, which flows into Grand Traverse Bay, and in which both trout and grayling are abundant, has this season sent me both kinds of fish. Being a native of western Massachusetts, where in my neighborhood trout were plenty, my prepossessions were strongly in their favor, but after trial we consider the grayling fully equal to the trout for the table. They are decidedly a game fish. I have not learned whether they are found in the streams of our upper peninsula, but it is well known that they abound with trout.

SUNDRY HUMBUGS.—Friends often write us about some swindling operation, and ask us to show it up in our Humbug Columns, if it comes within

"OUR SCOPE."

We have never in this matter stopped to consider what were the limits or extent of our "scope." We regard every attempt to get money without rendering a fair equivalent in return, as belonging to the genus *humbug*, whether the operation is in railroad bonds or postage stamps. We do not give much space to swindles involving large sums of money, as those are only practised among bankers, brokers, and other men, who are usually supposed "to have their eye teeth cut." It is these numerous minor swindles, where the sum concerned is a few dollars at most, that need exposure, for it is this class that find their field of operations among rural communities. When we say that farmers are more apt to be taken in by these swindlers, it is not spoken to their discredit. Persons who are perfectly honest and upright themselves, are slow to suspect others of wrong doing, and the man who has never defrauded another of a cent, can not conceive of the meanness which will stoop to wrong him.... We are tempted by some recent occurrences that came under our notice, to repeat some advice which we perhaps have already given in substance in former years. Almost every one, no matter where he may live, expects at some time in his life to visit New York city. While there are many other fine cities, there is but one New York, and every farmer's boy, every village clerk, and even every young miss, has an undefined notion that some day they shall see the sights of the wonderful city, of which their reading has told them so much. So it happens that thousands of strangers, from near at hand and from the far West and South, come to the metropolis solely for the purpose of sight seeing. At all times of the year there are numerous visitors of this kind in the city, but of all other seasons

OCTOBER BRINGS ITS CROWDS.

This month is the most favorable for seeing the city, the days are fine and cool, wanderers have returned from their vacations, the streets are full, the stores are at their best, and there is no other time at which the city is so attractive as in these golden autumn days. Where there are grapes there will be the foxes, and the rascals who make their living by prowling around, increase in proportion with the visiting strangers. Then swindlers, gamblers, and confidence men of all kinds, who have been plying their games at the watering places, the race courses, and the country fairs, or wherever people gather in crowds, are on hand in full force, to meet the crowd that this month assembles in the city, and a few words of

CAUTION TO STRANGERS IN NEW YORK

may save our visiting friends much annoyance and loss. Some of these swindlers, not content to await the arrival of their victims, go out to meet them, and many a man who has met an agreeable traveling companion on his journey to the city, has learned a lesson in regard to this kind of swindling that he will not soon forget. To those

unnsed to traveling we would say, be careful of showing your money. Only take out enough at stations to pay for tickets, keep sufficient loose change for incidental expenses in a handy pocket, and have the rest securely placed in some inside pocket. Having disposed of your money, don't fuss about it and every now and then feel to ascertain if it is safe, as there is no surer way of directing a pick-pocket than this. It is a safe rule to treat traveling companions with politeness, and nothing more; allow no sudden intimacies; if one persists in taking you into his confidence, the chances are that he has some end to serve. Don't change any large bills for any one, and do not tell any stranger what your business is, or where you are going to "stop." Those who have traveled much, and are good judges of characters, have no need of these cautions, but those who have had little or no experience, should be careful how they make chance acquaintances. Whatever you may do at home, by all means avoid

CARD PLAYING WHILE TRAVELING.

When wearied with a long journey, the temptation with some is very strong, to accept the invitation to make the fourth hand at a game of cards. It is safe always to decline, and often highly dangerous to accept. The "social" game is readily turned into a gambling one. "Only 25 cents a side to make it interesting," this point passed the end is not far. It is well known that certain lines leading from the city, are infested by well dressed "gentlemanly" gamblers, who "travel on the make," and we have seen persons stripped by them of every dollar, the conductor apparently knowing all about the little game. Within the city the traps that await the stranger are numerous. One of the common tricks of the street "bummers," is to run up to a stranger with open hand, pretending to be very glad to meet him, asking when he came to town, how he left the folks, where he is stopping, and all that; if the stranger does not know the chap, he says, "Oh! here comes Charlie," and Charlie is sure to know the stranger twice as well as the first one. It often happens that a good natured person, feeling the loneliness of a large city, thinks he might have known these persons at some time or somewhere. If he hesitates or stops to explain, he is quite likely to be taken possession of by his newly found friends, who will not leave him so long as he has a dollar. This thing happens almost every day directly in front of our office, and our young men, when they see it going on, do not hesitate to step out and inform the stranger of the character of his "friends." Another game is for these chaps to get names from the hotel register, and then call upon the guest with some story of being related, or other appeal to his sympathy. The only safe way for an entire stranger in New York, is to absolutely repel all advances of whatever kind from unknown persons. Let him make up his mind what points he wishes to visit during the day, and learn from the hotel clerk how to reach them. If he wishes information while on the streets, ask it of a policeman, and of no one else. Avoid auctions, "great sacrifices," "dollar," and other cheap stores of all kinds. If he wishes to make purchases, and has no friend to advise with, ask the hotel people for the names of respectable dealers, or consult the advertisements of the daily papers. Much more might be said in the way of advice to strangers in New York, and the same applies to other large cities, but we have touched upon those which our observation shows are most needed. Remember that money is the first requisite in traveling, and that next in importance is "common sense," which, among other things, will lead to the proper care and expenditure of it. So much space has been given to those swindlers to whom the victims come, that we have but little left for those who spread themselves over the country through the agency of the mail, but though our budget for the month is a "sizable" one, it is mainly a repetition of the old stories. We have frequently advised our readers to exercise caution in regard to the

CHEAP SEWING MACHINES

advertised so freely everywhere, except in New York. We have before shown that some of the machines were absolutely worthless, and a late complaint has come that money had been sent and no returns made. While we could not declare these sewing machine chaps swindlers, upon the unsupported assertion of persons not personally known to us, there was evidently abundant reason why we should put our readers on their guard. On the day we go to press, the morning papers announce the arrest of R. J. Mulligan, one of the parties against whom frequent complaints have been made. We are unable to give the result of the matter in the present issue. Probably those agricultural and horticultural journals, which advertised this concern so extensively, will be looking around for their advertising bills. Here is a circular of a grand gift concert, of the

MONTPELIER FEMALE HUMANE ASSOCIATION,

which claims to be a home for old, infirm, and destitute ladies, at Alexandria, Va. We have also letters asking

whether it is a humbug or not. Here is a most worthy purpose, that of providing needy women with a home, and it is endorsed and supported by gentlemen of the highest respectability, several of whom occupy distinguished positions in the State and National Government. Yet, notwithstanding all this, we place the scheme among the humbugs. That the lottery, for it is that and nothing more, will be fairly drawn, and that the funds received will be properly appropriated, we have not the least doubt. Indeed we have never seen a scheme of the kind, that was more thoroughly respectable, and on that account we regard it as one of the very worst. When we set this down among the humbugs, we do not imply that there will be any humbug in carrying out the programme, but our objection reaches back of that—to the character of the scheme itself. If we analyze it, we find that it is proposed to give "cash gifts," the modern name for lottery prizes, to the amount of \$1,000,000; (one million). There are 22,178 "gifts" offered, ranging from \$20 to \$100,000 each. To raise the money there are 100,000 tickets offered at \$20 each, wholes, halves, etc., in proportion. Suppose all the tickets to be sold, and all the prizes to be drawn, a thing by no means likely to happen, the tickets will bring in \$2,000,000. Of this \$1,000,000 must go for prizes, and that will leave \$1,000,000, out of which must come cost of advertising and circulars, discount to agents, pay of officers, and every other expense, and we think it not unfair to estimate, that under the most favorable circumstances can more than half a million finally go to the Association. Here, supposing each purchaser to invest in one whole ticket, one hundred thousand people will have engaged in this kind of gambling, in order that they may put five dollars each into the hands of the charity. The circular does not appeal to the benevolence of the community, but holds out the hope of gain as the motive for investment; governors, senators, and other dignitaries, give their names to a scheme which encourages the hope that by investing a little one may, *by chance*, get much. Now, we have no doubt that these very gentlemen are trying their best to shut up the policy shops in Richmond, Alexandria, and other Virginia cities, where the negroes squander their dimes upon just such a game of chance. Gentlemen, you have made a mistake! With your object we are in full sympathy, but your *scheme* is actually not better than "policy" gambling, and however distasteful it may seem, we must record you as responsible for a dangerous and immoral humbug. We notice that postmasters are solicited to act as agents for this and similar lotteries. Perhaps Postmaster-General Jewell will have a word to say on this.

WALL STREET GAMBLING.

Some parties who have no reputation at the Stock-board, but are known as "curb-stone brokers," send out very "promising" circulars, with a view to tempt persons at a distance to put money into their hands. If our Connecticut correspondent, who sends one of these circulars, knows so little about "put and call," "straddles," and other gambling farrago, that he must send to us to find out about them, his very safest way is to keep out of "the street," both in person or by proxy. Still, if he wishes to "know how it is himself," we can suggest no quicker way of finding out than to send a few hundreds to one of the chaps who issue these very taking circulars.

MEDICAL HUMBUGS

may be reported as rather quiet, the "fall styles" have not, at the early time at which we write, made their appearance. They will no doubt come next month almost as thick as the leaves which then fall—and not half so valuable. Our humbug correspondence brings us some strange confidences, but we have had nothing more touching than a letter from a gentleman in Pennsylvania in relation to the doings of an "oxygenated air" quack. This is a case, in which all feelings of delicacy should be put aside, and our correspondent owes it to the community that he should publish the whole affair over his own name. We have before stated that a proper regard for decency prevents us from publishing some of the worst quacks, who profess to be medical men. There are some things which we can not even mention in our pages, where the whole family must see them, but which ought to be exposed. The richest thing in the way of a circular, when we consider its English, which has a strong Eddie Eastman flavor, and the nastiest in respect to its object, professes to come from Trowland & Co., of London, who also have a branch-office in New York; we are sorry to deprive our readers of much fun, but decency demands. Rhode Island is not a very large State, but we think she can show more quacks to the acre than any other. The newspapers of Providence have a wide reputation for ability, yet their advertising pages are filled with quackery, and in a recent visit to that prosperous city, we noticed that quacks of all kinds had established themselves in respectable quarters: the number of "Chinese Doctors," "Catarrh Curers," "Readers of Mind and Soul," and all that sort of thing, were in most

appalling array. Providence presents an unusually intelligent community, its school system is almost perfect; that ancient seat of learning, Brown University, overlooks the city, and yet quackery flourishes there, as it rarely can elsewhere. We do not understand it.

Crusher for Bone or Plaster.—

"J. A. B.," Utica, N. Y. The Blake stone crusher is well adapted for crushing bones or plaster. This powerful machine reduces the hardest substances to small fragments, and bones and plaster can easily be made fit for the mill stones by it. It is made by the Blake Crusher Co., New Haven, Ct.

Yield from Two Potatoes.—

Charles Schultz, Canajoharie, N. Y. writes us that he planted two Early Rose potatoes on the 5th of May, and dug the produce, which was 4½ pecks, on the 25th of July.

Composting Manure.—

"H. C.," Bradford Co., Pa. Manure may be composted with muck, in proportion of 1 load of manure to 5 or 6 of muck. No lime is needed in the compost, nor is water necessary to keep it moist. This mixture will not heat injuriously. If it is evenly made it will not need turning. The muck alone is of very little use. Compost so made is a good dressing for meadows upon all sorts of soils.

To Improve a Rough Meadow.—

"A Reader," Ramsey Co., Minn. There is no machine that will cut off the tussocks or round bunches of sedge or grass roots, which grow upon wet meadows. They must be cut off level with the surface, with a broad sharp adze-shaped tool, or with a prairie-breaking plow, having a broad sharp share. They should then be gathered and burned. But the removal of these tussocks will be only a temporary expedient, unless the meadow is drained in some manner, as they will gradually grow in again and displace the cultivated grasses. Redtop is the only grass that will thrive upon such a wet meadow.

Value of Wood Ashes.—

"M. F. Van G. B.," Rondout, N. Y. Wood ashes are worth about 75 cents a barrel. There are 20 blocks to the mile in the avenues of New York City.

Garget.—

"M. F. Van G. B.," Rondout, N. Y. When cows have once been attacked with garget or inflammation of the udder, they are very apt to become permanently subject to it, and at every calving or change of health, the trouble will return. Much may be done by watchful care, in the way of prevention. When the udder is hard and swollen, and the milk is clotted and drawn with difficulty, a pound of Epsom salts should be administered to the cow, the udder should be bathed with cold water and greased with lard, and the milk should be drawn frequently.

Dysentery in a Calf.—

"C. A. N.," Morristown, N. J. Dysentery is a difficult disease to cure in a young animal. It is generally due to some irritating cause, which needs to be removed by a cathartic. For a three months' old calf two ounces of Epsom salts might be given, with half an ounce of ground ginger. If the discharges continue to be watery, cold rice water should be mixed with the milk, and a tea-spoonful of laudanum may be given daily. The greatest danger in cases of dysentery, arises from the want of prompt treatment of the previously occurring diarrhea. Diarrhea is readily cured by the above treatment, but when dysentery occurs the animal is generally much weakened, and the difficulty is complicated greatly in consequence.

Value of Merino Rams.—

"J. C. deW.," Albany Co., N. Y. We can not give the name of any particular breeder of sheep, who could supply Merino rams for \$25 each. No doubt by reference to the advertising columns the names of parties will be found, to whom you could write. The fancy prices for Merinos, which were current some years ago, have passed away, and by looking out for chances, fair sheep may be purchased very reasonably. We were offered a small flock of the best Vermont blood not long since, for \$10 per head. This was a somewhat exceptional case, but such cases are always happening.

See Pages 393 to 396.

George Such's Catalogue.—

Last year we published some account of Mr. Such's collection of plants at South Amboy, and we now have his catalogue—a very model of neatness and good taste, which he modestly styles a "Catalogue of some Stove and Greenhouse Plants, including Orchids, Palms, Ferns, etc."—"Some!" We should say so!—Here is this catalogue, over which we have pored and powdered, have read by day, and

dreamed over by night—waking only to find that all these treasures were not ours, but were away among the desert sand-hills of South Amboy—and he merely calls it a catalogue of "some" plants! Mr. George Such, you are dis-tressing in your modesty. If you had said "Catalogue of the finest collection of plants in America, and second to but few in the world," you would have told the truth. Here are plants, a single one of some of them equal in value to the whole stock of some florists, put down in as mat-ter of course way, as if they were ten cent verbenas or petunias. If you can quietly say that the price of such a plant is \$50, and upwards, if you can tantalize us with palms at \$150—\$250—\$350, and so on up to \$500—with others so choice, that we can only have "prices on application," why don't you blow?—Seriously, we give this catalogue of Mr. Such's an especial notice, because of its importance. It marks an era in American horticulture. Here is one who makes a business of selling plants, and he is too shrewd a man to offer that which he does not think can be sold; he has confidence in the increase of the love for fine plants, and foresees that our men of means and refined tastes will be willing to pay for the best, and he has brought together a collection that is simply wonderful, not only in the rarity of the species, but in the perfection of the individual specimens. Whether the investment in these choice plants shall prove profitable, or not, Mr. Such is a public benefactor, in placing them within reach of those who can afford to buy them, and the future of our horticulture will be largely influenced by his quiet exertions. Americans are known abroad as always wanting the best, but here Mr. Such places the best at their own door, and we are much in error, if the increasing taste for fine plants does not ultimately repay him for his enterprise.

Effects of Chemical Fertilizers.—

"A Reader." The common idea that artificial fertilizers help to exhaust land would seem to be supported by recent experiments by Professor Voelker of London. In some analyses of drainage water from soils that had been manured with chemical fertilizers he found that lime was rapidly carried off when ammonia-salts had been applied. He concluded that the ammonia soon became changed into nitric acid, which combined readily with the lime, and the combination being easily soluble, was quickly removed and lost to the soil. The ammonia of guano or other powerful manures would of course act in the same manner. For this reason we can not hope to keep our farms fertilized with guano or chemical manures alone. There must be barnyard manure, clover and lime, and the more of them the more ammoniacal manures are used.

The Boucherie Process of Preserving Wood.—

"C. G. M. B.," Detroit. The process known as above, was patented by Dr. Boucherie in 1833. It consisted originally of displacing the sap of a living or newly felled tree with saline solutions; those used by Boucherie were sulphate of copper, pyrolignite of iron, and chloride of calcium. The vital forces of the tree were utilized, and the saline solution was made to flow through the pores of the wood from a circular saw cut at the base of the tree, to the ends of the branches. Three years afterwards another plan was proposed; to force the solution into the wood by hydrostatic pressure. A water tight cap was fitted to one end of the piece to be operated on, and connected by a tube with an elevated reservoir of the solution, 50 feet above the timber. This process is largely employed in France and Germany, for preserving telegraph poles and railway ties.

Wrought Iron Plow Beams.—

"C. S. W.," Conrad, Minnesota. Plows with wrought iron or steel beams are made in Chicago. They are patented, and known as Kimplen's Malleable Iron Beams. They weigh about 30 pounds, and are stronger than any other kind of beam. We do not know the manufacturer's name, but any large implement dealer can procure them.

Clover in the South.—

"Subscriber," Spring Hill, Tenn. In many parts of the South clover has been successfully sown in the fall. Early in September is the time to sow the seed along with wheat or rye; if the soil is well prepared the clover may be sown alone, and will make a strong growth before winter, which will enable it to stand frost without injury.

Leaf Mold for Wheat.—

"J. B.," Oakland Co., Mich. Leaf mold would be of but little service for wheat unless applied in such large quantities, as materially to change the character of the soil. If applied largely, say 200 loads per acre or more, it would probably have some good effect. It would be better still, if 20 or 30 bushels of lime per acre could be mixed with it.

How to Make a Nest Egg.—

"M. S. A.," Dutchess Co., N. Y. A nest egg that can not be broken by frost or accident, and that can not be mistaken

for a fresh egg, may be made by breaking a small hole in each end of a hen's egg, and blowing out the contents. The shell is then filled with plaster of Paris, mixed with water to the consistency of cream. The plaster soon sets solid, and the egg can not be distinguished by the hen from other eggs, but its weight easily prevents it from being mistaken for a sound one. The plaster is such as is used for hard-finishing, and may be had of any mason or marble worker.

Shorthorn Bulls for Breeders.—

Farmers and writers for agricultural journals, have heretofore bewailed the impossibility of procuring bulls of good blood for breeding purposes, at reasonable prices. Notwithstanding, bulls are every day bought by breeders of stock for market, and are scattered through every State from Maine to Texas, making a great improvement in the quality of market cattle. Recently, at some stock sales in Kentucky, thoroughbred bulls of various ages from 5 months to a year, were sold from \$35 to \$100. It would seem that there is no reason now for a farmer to complain of inability to procure a good bull. If he does not get one, it is because he does not want one.

Professional Hedgers.—

"W. W. M.," Springfield, Iowa. Considering the want of knowledge as to the proper planting and the care of hedges, it is not strange that there should be so many failures. Scarcely one hedge in a hundred is a success, and it is probable that before long farmers will find it the best plan to contract with some one who understands his business, to plant and keep their hedges in order, paying a yearly sum for the purpose or hiring the work done by the day. In England where hedges are common, there are "hedgers," who do nothing but make and keep hedges in order. The well known Joseph Arch is a "hedger." It would be much the cheapest plan, and would be nothing more than a division of labor, which is so common a resort in regard to other matters. In the West the planting of hedges can not be abandoned, on account of the difficulties attaching to it. On the contrary it should be greatly increased.

The Western Farmer and Stock

Grower, by Milton Briggs, Davenport, Iowa; Day, Egbert & Fiddler. The appearance of this volume is pre-possessing, and when we came to read in the preface, that the larger portion of the farm literature was "not applicable to the Western prairie," and that agricultural writers, "such as never scented the new mown hay under a July sun" had been writing all sorts of errors, we felt, well here at last is the real thing. We read on, and on, and found such blunders as are only proper to ascribe to too much "July sun," and wondered what it was all about. After reading through 194 dreary pages, we learn on page 195 that the whole thing is an advertisement of Mr. Briggs's stock farm, which is in Jasper Co., Iowa, and we have no doubt a very good one, but if our readers wish to know any more about it, they can buy the book, in which besides this they will find recorded the views of the author on matters and things in general, including the nebular hypothesis, fungi, electricity, and not least the "mad-stone." If this is the kind of farm literature demanded by the Western prairies, we quite agree with the author, that the "older States" can not furnish it.

How to Build Boats.—

"M. K. F.," Griggsville, Ill. Full directions with illustrations for building light row-boats and skiffs were given in the *Agriculturist* for August, 1871, and October, 1872. Each number can be had for 15 cents.

First Lessons in the Principles of

Cookery, by Lady Barker; London: Macmillan & Co. This might more properly be called a plea for the National School of Cookery, at South Kensington. Its 100 small pages are mainly devoted to showing the need for instruction in cookery; its "first principles" are well enough what there are of them, but we can not see the least use for the book in this country, whatever there may be in England. 50 cts.

Liming Eggs.—

"Montclair." The "lime water," in which eggs are preserved, is properly the "milk of lime," that is, a mixture like a very thin white-wash. The eggs are placed in this, and kept in a tank or barrels in a cool dry place.

Limestone Water for Boilers.—

"J. W. J." When used for the Anderson or any other boiler, water that contains lime should be purified previously by some of the "anti-incrustation" preparations.

See Pages 393 to 396.

Effect of Tomatoes upon Cows.—

"A. K.," Chetopa, Kansas. We can not tell what effect ripe tomatoes would have upon cows. It is a question which may easily be determined by observation.

Catalogues, etc., Received.

While some dealers issue but one catalogue for the year, others put out one in the spring and another for the fall trade. The majority of those enumerated below, are fall lists made as supplementary to the main catalogues. In the early numbers of the *Agriculturist* for the present year, from February to June, will be found notices of the catalogues of a large number of dealers. We repeat here what was said in enumerating the catalogues last spring; we do not notice or allow to advertise, any party or firm that we do not consider as fair dealing men, and the fact that we make mention of their trade lists, is sufficient evidence that we consider them safe to order from; this is mentioned to save our friends the trouble of writing to us for our opinion of this or that dealer. Moreover, we cannot advise our friends at what particular establishment to make their purchases. Unless such inquiries are made in regard to some article not generally kept, we always decline to indicate a preference for one dealer over another.

NURSERIES.

OTTO & ACHELIS, Morris Nurseries, Westchester, Pa. Wholesale list of general stock and young evergreens.

A. HANCE & SON, Rumson Nurseries, Red Bank, N. J. Buds of peach and other trees, and grape vines.

BUSH & SON & MEISSNER, Bushberg, Mo.—Our esteemed friend, Geo. E. Meissner, has united himself with the celebrated house of Isidor Bush & Son, and what they do not have in the way of grape vines, will be difficult to find elsewhere.

BRONSON, HOPKINS & Co., Geneva, N. Y.—A full wholesale list of fruit and ornamental trees.

DOWNER & BROTHER, Fairview, Ky., succeed J. S. Downer & Son, by reason of the death of the senior Mr. Downer—and propose to sustain the well deserved reputation of the Forest Nurseries.

NICHOLAS & HEVSON, Geneva, N. Y., issue a very full wholesale list. This stock is grown upon the land formerly celebrated as the farm where Jas. O. Sheldon raised his Shorthorns.

C. P. LINES, New Haven, Ct., makes grape vines and small fruits his specialties.

THOMAS MEEHAN, Germantown, Pa., has a list remarkably full in the department of ornamental trees, including kinds rarely offered. He offers hedge plants in large quantities.

A. BRYANT, JR., Princeton, Ill., has a catalogue full in all departments, but especially in forest trees.

S. B. PARSONS & SONS, Flushing, N. Y.—A fine list of ornamental trees, etc., with evergreens, rhododendron, camellias and azaleas as specialties.

CALKINS & BROOKS, Bricksburg, Ocean Co., N. J., with a general stock, give special attention to peaches, apples, grapes and strawberries.

L. B. CASE, Richmond, Ind., with the general nursery trade, unite a large florists' establishment.

JONES & PALMER, Rochester, N. Y., offer large quantities of stock at wholesale rates.

J. DE SAINT-ANGE, Rochester, N. Y., is general agent for several French nurseries and seed-growers.

RANDOLPH PETERS, Wilmington, Del., has a very full catalogue; he is one of the largest growers of peach trees in the country, and we have personal knowledge that he sends out well-grown stock.

HOOPES BRO. & THOMAS, Cherry Hill Nurseries, Westchester, Pa., send two catalogues, wholesale and retail, which show that this old establishment is quite up with the times.

ELLWANGER & BARRY, Mount Hope Nurseries, Rochester, N. Y., have such a large and varied stock, that their different catalogues make a handsome volume. Besides general nursery and florists' stock, their fall catalogue announces a full assortment of bulbs.

FLORISTS.

Several of those whose main business is that of nurserymen, also deal in florists' stock.

ROBERT J. HALLIDAY, Baltimore, Md., offer camellias, azaleas, roses, etc., at wholesale as well as at retail.

GEORGE SUCH, South Amboy, N. J.—This remarkable catalogue has a special notice elsewhere.

LONG BROS., Buffalo, N. Y., publish their catalogue of winter-blooming plants in the form of a supplement to their "Home Florist." It contains very full and useful cultural directions, and is well illustrated. The "Home Florist" itself is one of the best things of its kind.

W. J. HESSER, Plattsmouth, Nebraska.—There is no more striking illustration of progress in the Western States than this price list, offering a general assortment of green-house plants, and at wholesale too! Alaska will be doing the same thing next.

SEEDS AND BULBS.

J. M. THORBURN & Co., 15 John-st., New York, are first in the field with their catalogue of bulbs and flowering roots: a very full list.

PETER HENDERSON & Co., 35 Cortlandt-st., New York, have also a full catalogue, in which, besides bulbs, they include grapes and small fruits, and a full list of garden requisites.

B. K. BLISS & Sons, at 34 Barclay-st., New York, have their new store well filled with bulbs and other stock, all of which their catalogue describes.

JAMES FLEMING, 37 Nassau-st., New York, whose place is by the removal of other dealers now an "old stand," also imports fine bulbs.

FRANCIS BRILL, Mattituck, (L. I.), N. Y., not only writes a book on seed-growing, but grows seeds for sale, and offers several choice varieties.

YOUNG & ELLIOTT, at their new store, No. 12 Cortlandt-st., which is the great auction flower-mart of the country, also have all the bulbs of the season.

JAMES VICK, who, it is hardly necessary to say, is in Rochester, N. Y., offers his usual stock of bulbs, which he sends very safely by mail.

HENRY A. DREER, Philadelphia, is also in the field with a general assortment of bulbs, and green-house plants of the season. That this house sends out well-grown plants, we can testify from personal experience.

BROOKS BROTHERS, Rochester, N. Y., make a specialty of bulbs, and also offer a choice assortment of winter-blooming house-plants.

BULBS IN BOSTON.—After this list was closed, the fall announcements of our Boston friends came in. We can not, at the last moment, give each a separate item, and it is sufficient to say that the well-known houses of Hovey & Co., Washburn & Co., W. H. Spooner, and T. D. Curtis & Co., have everything in the way of bulbs and seeds that can be found anywhere.

LIVE STOCK, ETC.

M. QUINBY, St. Johnsville, N. Y., offers bees, and all the requisites of the apiary.

HERBERT MEAD, Waccabuc Farm, Golden's Bridge, N. Y., catalogues Jersey cattle, swine, and dogs.

F. J. KINNEY, Worcester, Mass., believes in Brown Leghorn fowls, and tells about them in his circular.

IMPLEMENTS AND MISCELLANEOUS.

HARTFORD PUMP Co., M. C. Weld, Agent, 189 Water-st., New York. The remarkably ingenious machinery made by this Company, is described on another page.

G. T. PECKHAM, Providence, R. I., makes the fountain pump, and sends illustrated circular.

LORD'S HORTICULTURAL WORKS, Irvington, N. Y., turn out greenhouses and other glass structures, which are illustrated in a neat pamphlet.

EUROPEAN CATALOGUES.

E. G. HENDERSON & SON, London, N. W., Eng., send a catalogue of new plants, including all the novelties in soft-wooded stock.

WILLIAM BULL, King's Road Chelsea, London, S. W., Eng. Mr. Bull styles himself "New Plant Merchant," a name to which he is justly entitled, as the number of novelties he has brought into cultivation is something wonderful. Two monstrous catalogues, one of seeds, and the other of plants, the last named finely illustrated, are evidence of the extent of his collection.

CH. HUBER & Co., Heyeres, France, send a list of choice Primula and other seeds.

VILMORIN, ANDRIEUX & Co., Paris, France, present a list of seeds of all kinds, illustrated by the charming little engravings, that make their "Atlas of Flowers" so valuable. Their agents in this city are Pabst & Esch, 11 Murray-st.

JOSEPH SCHWARTZ, Lyons, France, sends a catalogue of roses, which are so great a specialty with him, that he calls his place "Terre des Roses," or Rose-land.

J. LINDEN, Ghent, Belgium. After the purchase of the renowned collection of A. Verschaffelt, Mr. Linden removed from Brussels to Ghent, where he maintains one of the finest establishments in the world.

J. C. SCHMIDT, Erfurt, Germany, besides a large collection of living plants, does a great business in flowers, grasses, and moss, dried, dyed, and otherwise, prepared for bouquets and other decorations.

L. VAN WAYEREN & Co., Hillegom, Holland, sends his wholesale catalogue of Dutch Bulbs, and informs us that he is represented in New York by Richard Lauer.

Industrial Fairs.

Besides the various State, County, and other Fairs, which are, or should be, mainly agricultural, of late years there have been held in various parts of the country, fairs, or "expositions," as it is now fashionable to call them, in which agriculture, if represented at all, is subordinated to other forms of industry; at these fairs mechanical arts and manufactured products, as well as the fine arts, are the main features. For a long time the American Institute of New York was the only exhibition of this kind, but recently the principal cities of the Union have held similar fairs, and found them not only interesting, but profitable. They are certainly deserving of every encouragement, as they bring together under one roof a view of the leading industries of the cities in which they are held, and also often show in comparison the productions of other localities. As not only products are shown, but frequently the processes by which they are produced are to be seen, these exhibitions are highly instructive, and they should be encouraged as important educational agencies. We are glad to notice that in Rhode Island all the manufacturing establishments in the vicinity suspended work for one day, in order to allow the employes to attend the recent N. E. Fair, and we would suggest to manufacturers in and near the cities where these industrial fairs are held, that the example of the Rhode Islanders is worthy of imitation. Indeed, those establishments which employ skilled, and in a degree permanent laborers, would find it a good investment to provide their workmen and their families with free tickets to these fairs. The return would come in increased intelligence as applied to their business. As the pioneer exhibition of this kind we mention first

THE AMERICAN INSTITUTE,

which opened the doors of its *forty-third* exhibition early in September, and will keep them open until the middle of November. October is the month in which New York is most thronged with strangers, to many of whom the Am. Institute Fair is one of the chief attractions; nor are the city people unmindful of the fair, and its spacious halls, especially in the evening, are filled with admiring crowds. This fair is some years better than at others, but we have never seen one of its exhibitions which did not amply repay attendance, or from which an intelligent person could not gain new and useful ideas. We go to press before we are able to visit the present fair, but learn that it is unusually attractive, especially in machinery and the processes of manufacture. The fair is held in the readily accessible and spacious hall, formerly the "Rink," which extends from the 3d to the 2d Avenue on 63d St.

THE CHICAGO INTER-STATE EXPOSITION

opened on the same day with that of the Am. Institute. Our representative there sends us a full account, but we have only room for the following extracts:

"The building is one-third larger than it was last year, the greater part of the added space being devoted to agricultural implements and machinery, and to floral products. The floral display is an extraordinary one, both as to character and extent. Eastern as well as Western professionals are represented, and amateurs have contributed. In the machine department nearly all leading manufacturers of the country are represented, those of the West assuming scarcely more prominence than others. In farm products the principal display is made by the land grant railroads, interested in calling attention to the productiveness of the sections along their roads. While these displays are very fine, they are chiefly remarkable as showing what a well organized effort can do in bringing prominently before the public the productiveness and peculiar excellence of a particular locality. Outside of this department, the display of farm products is not specially noticeable.

"The fine art department contains the largest collection of fine paintings ever exhibited in this country, contributions coming from New York and other Eastern cities, to be added to the collection from the West. This has the character of a National exhibition.

"Other departments show the business of Chicago in miniature. All that is curious or worthy in manufacturing is represented.

"The Exposition Building is at the foot of Adams St., four blocks east of the Western office of the *American Agriculturist* in the Lakeside Building. Our friends in the West, while visiting the great representative exhibition of the North-west, will have a hearty welcome extended to them at our Chicago office."

THE CINCINNATI INDUSTRIAL,

which was such a marked success last year, is advertised to close on the 3d of this month. From the extended report of last year's show we feel warranted in advising our Western friends, who get this notice in time, to make the most of the last few days.

THE LOUISVILLE (KY.) EXHIBITION

keeps open until Oct. 7th. This fair proved a great success last year, and presented several novel features.

THE FRANKLIN INSTITUTE

celebrates its semi-centennial by an exhibition at Philadelphia, which holds from Oct. 8th to 31st. An unusually favorable location has been secured, and this will probably be the greatest mechanical display ever seen in the country.

THE NEWARK (N. J.) INDUSTRIAL FAIR

is open as we write, but we are not informed how long it will continue. It is an interesting epitome of the wonderfully varied industries of Newark.

Supplementary List of Fairs.

The following list gives the later fairs not in the one published last month. Some changes of date are given here. See list of last month (September) for other fairs to be held in October or later.

MAINE.

Kennebec East.....South China.....Oct. 6-8
Kennebec North.....Waterville.....Oct. 6-8
Knox.....Thomaston.....Oct. 6-8
Jay.....Jay.....Oct. 7-8
Somerset Central.....Skowhegan.....Sept. 29-Oct. 1

VERMONT.

Barton.....Barton.....Sept. 29-Oct. 1
Rutland.....Rutland.....Oct. 6-7

MASSACHUSETTS.

Norfolk Club.....Norfolk.....Oct. 7-8
Stow.....Stow.....Oct. 2

CONNECTICUT.

Hartford.....Bloomfield.....Oct. 1
Milford and Orange.....Orange.....Sept. 30-Oct. 1

NEW YORK.

Catskill.....Catskill.....Oct. 1-2
Columbia.....Hudson.....Sept. 29-Oct. 1
Hudson River.....Poughkeepsie.....Oct. 20-23
Skaneateles.....Skaneateles.....Oct. 7-8
Westchester.....Yorktown.....Sept. 29-Oct. 1
Yates.....Dundee.....Oct. 14-16

NEW JERSEY.

Burlington.....Mount Holly.....Oct. 6-7

PENNSYLVANIA.

Carbon.....Leighton.....Oct. 6-9
Chartiers Valley.....Canonsburg.....Oct. 13-15
Cumberland.....Carlisle.....Oct. 6-9
Greene.....Waynesburgh.....Oct. 14-16
York.....York.....Oct. 6-9

MARYLAND.

Alleghany Valley, W. Va. & Penn. Cumberland. Oct. 20-23

VIRGINIA.

Baldwin-Augusta.....Staunton.....Oct. 13-15

OHIO.

Fairfield.....Lancaster.....Oct. 14-17

WISCONSIN.

Dodge.....Beaver Dam.....Oct. 5-7

IOWA.

Delaware.....Manchester.....Sept. 30-Oct. 1
Jasper.....Prairie City.....Sept. 29-Oct. 2

MINNESOTA.

Martin.....Fairmount.....Oct. 8-9

CALIFORNIA.

Santa Clara Valley.....San Jose.....Oct. 5-11
San Joaquin.....Stockton.....Sept. 29-Oct. 3
Southern.....Los Angeles.....Oct. 25-Nov. 1

PROVINCIAL.

Nova Scotia.....Halifax.....Oct. 5-10

The New England Fair.

The fair of the N. E. Agricultural Society was this year held in conjunction with that of the R. I. Society, at Narragansett Park, near Providence. Those who have visited this race-course, which was built by Col. Amasa Sprague, in the days of the great prosperity of the Spragues, know that it is unequalled in the country; everything about it, even to the smallest accessory, is of the most thorough character. No society ever had a finer place for a show, and in some respects the show was worthy of the place. In cattle the exhibition of this year has not been excelled by that of any former one held by the Society, indeed, the strength of the exhibition, to all but horse people, lay in the cattle, which included bulls, cows, and calves of all the leading breeds, as well as grades, fat cattle, and working oxen, and these came from every New England State, though Rhode Island was most largely represented in proportion. We have not space to enumerate the fine animals, or even the premium herds. The show of different breeds by Mr. George F. Wilson, of Providence, was remarkable for size and excellence, and the rare Swiss cattle of Messrs. Aldrich & Hall, with their picturesque collars and sweet-sounding bells, attracted much attention. The commodious stalls of the park al-

lowed a better inspection of the horses, than one can usually make at a fair. Swine and sheep were not in large numbers, but good animals of their kinds were shown, and while the poultry was not so numerous, as all New England ought to show, there were some excellent coops. In the poultry-tent we observed an instance of great cruelty to animals; right in the midst of the fowls was a coop containing a pair of foxes, the mental distress of these animals thus surrounded, must have equalled that of Tantalus, and is recommended to the attention of Mr. Bergh. The halls attached to the grand stand afforded room for the display of manufactured articles, sewing machines, and the like, while other machinery and agricultural implements were shown in an enormous tent near by. The display in all departments in this tent was very full, and was largely enhanced by the contributions of Messrs. W. E. Barrett & Co., of Providence, one of the heaviest houses in this line in New England. The horticultural portion of the exhibition was held in the city, at Howard Hall, a spacious room, which was well filled, though largely by Rhode Island growers; Hovey & Co., of Boston, had a large show of pears, and Vick, of Rochester, was represented by a good display of annuals. The time was rather too early for the best display of fruit, and the R. I. Horticultural Society, at their exhibition some weeks later, propose to excel this in excellence. The vegetables were remarkably good, though not so numerous as they should have been.

We have not yet heard the pecuniary results of the fair, but if it did not pay expenses, it should have done so, for the arrangements for exhibitors, spectators, and the press, were in all respects admirable, and if we mistake not, credit for these is largely due to the labors of Col. Pitman, Secretary of the R. I. Society. While we record high praise to the fair as a whole, we are obliged to point out some faults. The exhibitions of the N. E. Society have more than any others been of the horse, horsey, and the present was no exception; we believe strongly in the utility of "that noble animal, the horse," but can not see what agricultural bearing there is in the fact, that a certain gray mare went round the track in two seconds less time than a certain brown gelding. There is no getting over the fact that this was an agricultural horse-trot, with other matters as appendages. The N. E. Society is an important one, and its influence in degrading fairs into horse races has not been for good; we have, however, reason to hope for better things, as Col. Needham, the secretary, stated at one of the evening meetings, that he hoped the time was not far distant, when the Society could hold a fair without depending upon horse-racing—or words to that effect. Another glaring fault at this fair was the admission of all sorts of side-shows within the grounds. If armless, under-lean, and over-fat humanities must exhibit their deformities, pray keep the disgusting things outside of the fair-grounds. Quackery of all kinds, that should have been kicked outside of the gate, was rampant within the enclosure. The President of the N. E. Society hears, and we doubt not rightfully, the title of *Doctor*, yet within hearing of his tent there stood a mountebank, all decked with gold-lace and other finery, in his gaudy baronche, with a servant in showy livery, and this arrant quack was allowed to cry out the virtues of his vie compounds without hindrance. Gentlemen, who manage the N. E. Society, we have a right to expect better things of you. We do not like to find fault where there was so much to praise, and we trust that the toleration of these nuisances was an accident that may not again occur.

Our Patent Department.

In so large a circle as the readers of the *Agriculturist*, there will, of course, be many inventors, and probably many times more among our readers than in the same number of persons who do not take the paper. In years past a considerable share of our correspondence has been in relation to inventions, and we have been frequently consulted as to the advisability of patenting this or that invention, and often asked to put the inventor in the way of procuring a patent. In all this correspondence, complaints were not wanting of enormous fees charged by patent-agents—fees, which seemed to us out of all proportion to the service rendered. As the Patent Office is a department of the government, and is presumably for the benefit of the people, we could not see why persons wishing a patent should not deal directly with headquarters and dispense with patent-agents altogether. With our then knowledge of the subject, it seemed that the people should have direct access to, and deal directly with, the officers placed in the Department for the express purpose of attending to the very business, which inventors pay the agents for doing. Having excellent friends in the Patent Office, we consulted with these, as well as the Commissioner himself, as to the propriety of advising inventors to have nothing to do with agents, but to deal directly with the office. The result of these interviews

quite changed our notions. In an ordinary court of law a man may manage his own case, and may possibly succeed; the probabilities, however, are that he will fail, and his failure is likely to be due to a want of knowledge of the law. While those who wish to manage their own cases at the Patent Office, will find the officers ready to offer them every facility, they must take the risk of the mistakes into which they must fall from not knowing the laws. The patent laws are so many, and have been so modified and variously complicated—by the law-makers and not by the officers of the Department—that it is hardly possible for one not versed in patent laws to manage his own case to the best advantage. So, while here and there an inventor may be able to get along without the aid of an attorney or agent, we were quite convinced that it is, as the laws now are, better for the inventors, as a class, to engage competent advice and aid. We are well aware—and we are quite sure that the officers of the Department agree with us—that there is much about the existing laws that is absurd and useless, and that they should be greatly simplified, but as long as the laws exist, they must be complied with, and until the whole code is revised, it becomes a necessity for inventors to seek the advice of those who have given special study to the laws as they now stand. In order to offer inventors intelligent aid in this respect, we some months ago associated with ourselves a gentleman, who has made a speciality of patent matters, and one who stands very high in the esteem of the officers in the Department at Washington, and are thus able to offer the best possible services at reasonable rates. Though we have not announced this department of our business otherwise than through these columns, the number of patents it has secured has been very encouraging, and the letters of those who have obtained patents through its aid, express the greatest satisfaction with the manner in which it is conducted. It is hardly necessary to ask our subscribers to send their patent business to this office, but we do ask them to do us the favor to mention our patent department among their inventing friends, and assure them that their patent business will be attended to promptly, and that they will be dealt with fairly.—Circulars may be had on application.

"Walks and Talks" Correspondence.

AGE OF BREEDING SOWS.—"D. F. C." Scott Co., Iowa, writes that the general custom there is to breed from young sows. They aim to have the sows farrow in April and May; they are then fattened for market the next fall. This plan is very convenient, but it will not do to breed the sows too young. I seldom let my sows breed until they are 15 or 18 months old. Breeding continuously from such young sows only, the breed would degenerate. It would be better to wait 6 months longer. The pigs intended for breeders should be fed liberally until 5 or 6 months old, after that they should have plenty exercise, and less nutritious food. During the following summer and autumn they will need nothing but pasture, and the run of the stubbles after harvest. The sows will be strong and fully matured, and will probably prove good sucklers, and will soon recuperate after the young pigs are weaned, and can easily be fattened early the next fall.

ESSEX OR BERKSHIRE.—"D. F. C." further says: "I have a cross of Berkshire on Poland-China sows. The pigs are fine enough in the bone; but the Berkshires are a little too wild to suit me. Would the Essex be better than the Berkshire in this respect?"—The Essex are distinguished for being remarkably quiet. But much depends on how they have been bred and managed. A well-bred Essex hoar, with a good grade Poland-China sow, would make a capital cross. I can think of nothing more likely to give perfect pigs, unless it is one or two more crosses of Essex blood. If white pigs are preferred, I would select good grade Chester White sows, and cross them with a well-bred Suffolk. I think the handsome litter of pigs I ever raised, was from a large grade Yorkshire sow and a pure-bred Prince Albert Suffolk boar.

ABOUT FERTILIZERS.—"A. J. C." Fairfield Co., Ohio, writes: "Much is said in the papers about superphosphate of lime, salt, plaster, etc., but I do not know of any being applied in this neighborhood, and I would like to make some experiments with them."—That is right. Try them on a small scale. I have never seen any decided benefit from the use of superphosphate on wheat. I have always seen it applied broadcast to wheat. For turnips, it is a well ascertained fact, that it is best to sow it in the drills with the seed. It has an almost magical effect on the young plants, causing a great development of roots, and a rapid growth of leaves. When superphosphate is sown broadcast on turnips, it has ultimately a beneficial effect, but you do not perceive such a marked result in the growth of the young plants, as when it is drilled in with the seed.

SUPERPHOSPHATE ON WHEAT.—I have always said that it would not pay us to use superphosphate on wheat. But some, in this section, have been using it for a year or two past. One of my neighbors used it last year on part of his wheat field, and I could see little or no difference in the crop. Another states that he also used it, and could see no benefit. Both applied it broadcast. On the other hand, several farmers who have drilled it in with the seed, report a very decided benefit from its use. In this section very few of our drills have a fertilizer attachment, and I am not sure but that these reports of the great advantages of drilling the superphosphate with the seed are made in the interest of the makers and agents of the drills with fertilizer attachments. Drilling in the superphosphate with the seed is worth trying. But it will require more evidence than I have yet seen to convince me that superphosphate is a profitable manure for wheat at present prices.

PLASTER ON WHEAT.—"A. J. C." further asks: "Will it benefit the wheat crop to sow gypsum or plaster in the drills with the seed? Will it be better alone, or will it add something to sow salt with it?"—I would drill in the plaster with the seed—say two bushels per acre, more or less. More will do no harm, and it is said that one bushel is enough. Here, when plaster is cheap, I frequently sow four bushels per acre on clover. I would not mix the salt with the plaster. There is nothing to be gained by it, and the salt, when drilled in with the seed, might be injurious. Sow from three to five bushels per acre broadcast on the land before or immediately after sowing the seed.

SALT AS A FERTILIZER.—Occasionally great benefit is derived from an application of salt to wheat, and still more frequently to barley and mangel-wurzel. The Onondago Salt Co. sell an impure salt for manure at a mere nominal price.

USING LIME.—"Will the wheat crop be benefited," asks the same correspondent, "by sowing lime on the plowed land, and if so, how much per acre?"—Lime almost invariably proves beneficial on drained land, but not on land that is wet. Whether it will pay or not depends somewhat on the price. If I could get it for 15 cents per bushel, I would use it freely. In regard to the quantity per acre there is much difference of opinion. I would put on 80 bushels per acre, or half a bushel to a square rod. The land will show the effect of the lime for many years.

WHEAT FROM OREGON.—James Aitkens, Marion Co., Oregon, sends me several heads of Chili Club Wheat. His crop was sown in the fall. Usually this wheat is there sown in the spring. I think I never saw larger or handsomer heads of wheat. I counted 126 kernels in one head. I suppose it would be claimed as an "amber" wheat, or from that to white. Mr. A. thinks it would be too tender for our climate. He says, parts of his field this year would yield 45 bushels per acre, and the only reason why the other parts do not yield so well is "simply owing to poor cultivation." "This field," he says, "and it is only a type of hundreds of others, has been in cultivation, wheat and oats, about 20 years without anything being returned to the soil. Last year it was poorly summer-fallowed, and some manure hauled on to it in places. There was a larger growth of straw where the manure was applied, but I think there was no more grain."—Probably another twenty years will change all this. I presume even now the average yield of wheat in Marion County falls very far below these figures. I do not mean by this that the land is becoming "exhausted." I think it is quite probable that the crops are as good as they were 20 years ago. But I presume that then, as now, there were a good many poor spots that pulled down the general average. Is it not so?

Bee Notes.

BY M. QUINBY.

If you failed to notice the condition of your bees last month, do not put it off another day. If the suggestions then given were carried out, the main thing now is to ascertain the amount of winter stores. It is best to weigh them. Old combs are often well supplied with bee bread, and are heavier than new combs that have more honey; 25 lbs. of clover honey is the least that is safe, 30 lbs. is safer, 60 lbs. is more than is necessary, and unless properly stored, would make wintering very hazardous. If you have no means of weighing, without more trouble than the bees are worth, let me try and give a rule for guessing at the quantity of honey. If you purchase bees before winter, you may want to feel sure that they have honey enough. Say the hive has eight combs, each containing 160 square inches, these eight combs will average half full of sealed stores, not far from 4 lbs. each. If everything has been cared for in the regular course, the outside ones will be nearly full, while those

in the middle may be a quarter or third full of sealed honey, some unsealed, and some empty cells, which the young brood has just vacated. Such a state of things is most favorable. In *guessing* at the quantity, by surface of sealed honey, another thing should be observed. If combs are straight, and just one inch and a half apart, they are more uniform in thickness and weight, than if irregular in distance apart. I have seen hives fitted up with so little care, that six frames occupied the place of eight. In a space of 12 inches, some of them might be 2 or 3 inches thick, while an inch and a quarter would be just right for sealed honey. It is more difficult to judge in such a case. . . . A visitor just related what he thought a curious fact. A new swarm of his had built two combs on one frame the whole length, true and nice. I could not help telling him that he had not frames enough for the width of his hive, or that some of them were too close. I could not quite see how he would manage to extract, or how he would find the queen, if she should happen to be between the two combs. . . . Here is another point, frames should be just so far apart, all of one size, and all alike. After all, a little too much honey is better than none at all towards the spring, but a good deal too much is fatal. Unusually thick combs when filled, are more unsafe than those of proper thickness. When the bees build their own combs, and happen to make them straight, as without frames, they are near the right distance apart. But when made crooked, the crook of each comb does not always match with the crook of the next one to it, and spaces will be left if there are no long cells to fill out with. Sometimes there will be a space rather larger than they like to fill with long cells, and not quite large enough for another comb, resulting in a thin comb with cells too short for any purpose. Hence the economy of straight combs, and having them the right distance apart. The earlier bees can be put in condition for winter the better, and the more likely they are to get through.

The early part of this month, will be the time to expect some of the neighbors to complain of bees destroying fruit. I wish that every truthful bee-keeper and orchardist, might scrutinize a little more closely than they ever before did. Whenever complaint of the bees is made, see if the bees make the attack in the beginning. If you have fruit of your own, you will have all the better chance. Watch patiently, not to shield the bees from judgment if guilty, but to get at facts. If it can not be determined in any way by watching them attentively, you can make one further effort that might prove more satisfactory. Bees are out of the way in many places, or nearly so. In most sections of the Eastern States, no more honey is accumulated after this time, and bees may as well be kept at rest as roaming about. If they were housed in a cool, dark cellar, the whole of this month, they would be better off, and the trouble would be more than balanced, by the good feeling promoted between neighbors. Carrying them in, is much better than shutting them up, which is often ruinous. Have every hive numbered, likewise the stands to correspond, and after fruit is all secured, return them for a few days, if thought necessary before winter. We may yet find there is nothing lost by housing for winter, as soon as all the brood is hatched. When the bees are set out of the way, and the pears and apples are found rotting as badly as before, the grapes punctured and spoiled for market, without the bees, I hope we shall trace the trouble to where it belongs.

The profits of bees when rightly managed, ought to repay even this trouble. I hope to be able to give some of the results of improved management next month. These results do not come from those who think that procuring a dish to catch porridge is all sufficient. The farmer's cattle must be cared for two or three times daily, for half the year. Daily care for the bees may be needed, when we learn how to apply it. We have learned this much, that whenever care of the proper kind has been given, it has always paid.

Phillip's Spiral Corn-Husker.

The machine which is illustrated upon our first page, is known as the "Phillip's Spiral Corn-Husker," from the peculiar form of the rollers, which strip the ears from the stalk, and the husks from the ears. It is run by two or more horses, and is able to husk from 500 to 1000 bushels of ears per day. Hand-machines, to be operated by two men, can husk 200 bushels per day. The corn-stalks are fed into the machine from a table, upon which they are spread out, butts foremost. They are seized by the spirally grooved rollers, and crushed, as they are drawn through; when the ear reaches the rollers, as it can not find room to pass between them, it is torn from the stalk, drops into the sloping groove, and is immediately seized by the spiked rollers, seen beneath the machine. A portion of the casing is shown in the engraving as being cut away, so that these rollers may be seen. The stalks pass to the front of the machine, from whence they are taken occasionally, and bound into

sheaves. The crushing they receive helps greatly toward their rapid curing, and makes them more easily cut in the fodder-cutter. The husks are stripped cleanly from the ears, taken by the rollers, and deposited in a box or basket beneath the machine, where they are ready to be removed for final disposal. The ears are dropped separately from the nibbins at the rear of the machine, where they may be caught in boxes or baskets, and carried to the crib. It makes very little difference in time or labor, whether the husking is done in the field, in the barn, or in the barn-yard. It depends greatly upon the condition of the fodder, if that is dry, the husking may be done in the barn, or where the corn is to be stacked. Some economy of labor, of course, depends upon the arrangement of the work. We do not say that this machine is a perfect corn-husker, by any means. That is not to be expected of any machine so recently introduced as this is. But that it is able to facilitate greatly the slow and costly labor of husking corn, we are assured, and as it is not only the best husker we have, but the only one that can be operated by horse-power, its use is one of the absolute necessities of the corn-grower.

Ogden Farm Papers.—No. 56.

I have recently had a visit from the younger member of the firm of J. I. Boies & Son, Marengo, Ill., to whose dairy allusion has several times been made in these articles. I wish I could give to every reader of the *Agriculturist* the exact impression that his statements made upon me. They contain a wealth of suggestion for enterprising farmers at the West.

Mr. Boies is young, energetic, frank, and outspoken. He and his father have had ups and downs in life, and have had some rough business experience. They have taken to their new enterprise, good natural abilities, some commercial training, and the discipline of some misfortune. Their farm contains 300 acres of land, which was bought a few years ago, as "worn out." It lies 60 or 70 miles northwest of Chicago. As already stated, they keep from 100 to 130 cows, buying all the ground feed they use—which is a great deal—and buying milk in addition to that which they make themselves, supplementing their operations with the making of much pork, and incidentally of an enormous amount of rich manure.

The first year their corn crop was 35 bushels per acre, the next 45, the next 75, and the next 96 bushels—not by an estimate or guess, but by actual weighing over their hay scales. Their dairy operations are simply stupendous; at the height of their season they make 600 lbs. per day, and will probably average 400 lbs. They last winter shipped 25,000 lbs. to one dealer in Providence, R. I., and he expects to want more this winter. They supply several large hotels in Chicago, and have a shipping custom to other points. They receive from 35 to 45 cents per lb. I did not ask especially, but conclude that their average would be rather over than under 40 cents per lb., *at the farm.*

The milk as soon as drawn, is strained into deep pans, similar to the Orange County Milk Pans, standing in an underground room, which is kept at a temperature of 60° in summer, by the circulation of air under the adjoining ice-house. The milk is skimmed at the end of 36 hours. The churning is done in a revolving four-sided box churn. The butter is washed in the churn only, thoroughly worked, and receives $\frac{1}{4}$ oz. of salt per lb. Mr. Boies is his own butter maker, and attends to every detail with great care. He has found no difficulty in making sale for his product at the prices stated above—which I consider more remarkable in view of his location, and of the quantity to be sold, than \$1 per pound near Eastern cities. Pork, of course, constitutes a very large source of income.

On my way to the St. Louis Fair in October, I hope to visit this dairy, and may write further about it. In the meantime, I am very much impressed with the fact, that there is a suggestion here for the relief of agricultural distress in the West. Butter is by no means the only product that can be made there, and be shipped cheaply to Eastern cities, for sale; cheese-making would probably be nearly as successful. The great point is so to regulate the business of the farm, that none of its crops shall be sold away. Turn everything into butter, cheese, pork, beef, mutton—something that can be transported without the enormous cost of sending grain; and the production of which will supply the farm with ample manure. It is a number of years since I have been at the West, but I assume that I no longer run the risk of criticism, if I say that even on "the exhaustless prairies of Illinois," the manure question is *the* question, and that neither railroads nor middlemen can have a tittle of the influence in dragging down Western agriculture, and making poor men of Western farmers, than can the sale of hay and grain, and the neglect to collect and provide ample manure. Naturally nine-tenths of the farmers at the West will be guilty of this neglect, and will suffer for it, blindly refusing to see the source of their misfortunes, but the few enterprising men, among whom I hope we number our readers, can not fail to be stimulated by such examples as the one set forth, to adopt and faithfully pursue a course of radical reform, looking for their money income to articles of little bulk and good price, and retaining on their farms everything that can add to the fertility of the soil.

At the West as well as at the East, it seems to me that the happiness and prosperity of farmers would be increased, by the return—if such a return were possible—to the "good old ways." I do not mean, nor do I believe, that it is desirable to produce everything consumed so far as possible upon the farm itself, for cloth can be woven in mills cheaper than in private houses, and there are better advantages for selling home produce, than existed before the era of railroads. At the same time money is too important a factor in the life of modern farmers—we have all of us been more or less corrupted by the high prices and flush money of the war times, and of the plentiful paper dollars prevailing since then, so that we have made our comfort depend too much on the ability to spend money. A farmer's income to be sure, substantial, and satisfactory, must be very largely in other things than money. An improved home, richer land, more convenient buildings, and more carefully bred and reared stock—these are within his reach without the outlay of much ready money. Home labor and the capabilities of the farm, will supply them if properly directed, and if patiently waited for, without the hiring or buying of outside helps. The tendency to measure prosperity by the amount of money that a farmer has in outside investments, or that he is able to spend for his pleasure, is giving a wrong tendency to our whole system. Farmers can not hope to compete in this respect with merchants and manufacturers, whose business is much more speculative and full of risks, and who too often give a fictitious evidence of wealth, by spending the money which they *hope* to earn, and which is not seldom lost by farmers and other producers who have trusted them.

Taking the whole merchant class of America, including their clerks and porters, they would probably show at the end of 25 years, less actual honest earning than the same number of farmers and farm-laborers. The growing tendency to spend money, and to count their wealth in dollars and cents, rather than in more substantial possessions, is assimilating them more and more to the speculative classes, whom they are so apt to decry. Let us get all the real advantage that we can out of modern civilization, but let us at the same time avoid so far as we comfortably can all that takes cash money, and gives a fleeting pleasure as our only return.

The English Agricultural Gazette has, for a number of weeks, been publishing the early education and training of successful farmers, in different parts of the Kingdom. It is almost discouraging, in view of what is so generally hoped as the outcome of our agricultural college system, to see how very few of these men had anything approaching a liberal education, and how often the 3 R's alone appear as the representatives of the schooling received. Those of our people who are longing to get out of their occupations, and to become farmers, would probably also be somewhat discouraged to see in how very few instances among those cited, the successful farmers have adopted the business late in life. Farmer's sons and farm-laborers have furnished the stock from which nearly the whole list has been drawn, and especial importance is attached in nearly every case, to very early training to hard work, and to the manifold cares of the stable and field. All this does not by any means indicate that success can not be attained, by men who have not sprung from the families of farmers and farm-laborers, nor by well educated sons of farmers, but it does suggest the importance of sound rudimentary training, and a strong inclination toward the farm rather than away from it. It makes it clear too, that farming is a business which requires no small share of energy, attention, and acquired skill; that it can not be gone into hap-hazard with only the knowledge that comes from schooling, and one or two years of experience with a good farmer. It requires thorough ingrained training in every detail of farm work, a real love for it, and a determination to succeed in it. Any young man starting life with these qualifications, may be considered safe to stay on the farm; not because of a sentimental liking for it, but for the much better reason that he knows that there he can make more money, and earn more substantial success in life, than in any other occupation that is open to him.

A friend writes me of a visit to the farm of S. J. Sharpless, in Chester Co., Penn. He says: "Sharpless has been doing well. 14 cows made last week (Aug. 6) 105 lbs., equal to 7½ lbs. each. They averaged 4½ months from calving." In a subsequent letter he says: "In mentioning the production of Sharpless' cows I forgot to say that they are running in clover half way to their knees night and day." So we may ascribe a part of the success to the Jerseys, and a part to the feed—a combination that is hard to beat.

I have long wished to identify myself with the sheep interest, which seems to me one of the most important to American agriculture, but have been prevented by the lack of suitable accommodations at home. Several attempts

made in this direction have turned out decided failures, mainly owing to the lack of sufficient fences and the inuriousness of too many dogs in the neighborhood. I have recently bought a half interest in the Cotswold flock of Mr. D. F. Appleton, of Ipswich, Mass. I hope in future to be able to report good success with them. The flock numbers about 75; it was begun with a lot of good ewes selected in Canada; and a fine imported ram, "Young America," bought from J. D. Wing, of Maple Shade. Mr. Appleton subsequently imported a lot of ewes from Howell, and 2 rams from William Lane, in the Cotswold hills in England. The rams cost \$300 each, and the flock has taken first prizes whenever exhibited at the New England Fair.

A correspondent in Iowa, who has a remarkably good Jersey cow, concerning which he has frequently written me, and whose product of butter I am satisfied is over 2 lbs. per day, asks what he shall do for a bull, as there is none available in his neighborhood, except a calf of this same cow. I reply: "If the bull-calf is sound, and was got by a fairly good bull, I should use him upon his dam, his sisters, his daughters, and his grand-daughters, as long as he lasts, unless the experiment showed some defect in its early stages. When you get such a cow as that, you had better take the chances of in-breeding and try to secure her perpetuation. I should do it myself."

In-breeding, as a rule, is of course not to be recommended, but in-breeding as an exception is often very successful, and it is always worth while in the case of a remarkable animal to run the risk, and resort to what is of course much the best means for perpetuating good qualities and establish valuable strains of blood. The experience of Shorthorn breeding is of itself a sufficient indication of the wisdom of taking such risks.

"A. M. E.," of Providence, writes: "In your Ogden Farm Paper No. 54, you say the increasing richness of the milk of native cows served by a Jersey bull may be sufficiently accounted for by the fact of their increasing age. This greater age is doubtless one reason for increased richness, but is not the latter also a proof of the influence of the male on the whole organism of the female? Darwin cites the case of a chestnut mare, which was served by a male quagga, and subsequently her foal by a black Arabian stallion, was barred like a quagga." The effect on the character of subsequent progeny by the character of cross-bred progeny is tolerably well known to most breeders. A bitch that has thrown mongrel pups can not be trusted to bring a whole litter of thoroughbreds thereafter. The same peculiarity has been noticed in other animals, and there is undoubtedly some influence exerted by progeny crossed with another breed, upon whatever it is that determines peculiarities of all subsequent progeny of the same mother. It would, however, be carrying the analogy too far to suppose that this influence on future descendants is accompanied by a transforming influence on the mother herself, at least to such an extent as to alter the character of her milk secretion. Being a champion of the Jersey race, I should be glad to claim for them any such mysterious quality as the one referred to, but I do not believe that it can honestly be done.

I have the following from Alabama: "You are not perhaps aware that it is well-nigh a universal practice in the South, with those who

make butter, to wait until the milk or cream is "turned" (as it is termed) before churning. I have seen in my neighbors' houses wooden churns charred until black by roasting them before the fire, to make the milk "turn," to "clabber" in cold weather. Here is the *modus operandi*: the milk is skimmed, and the cream placed by itself, until the last milking just before churning is brought in. Into this the accumulated cream is poured, and that is left to stand or placed near the fire until *clabbered*, and then churned.

"I think your practice quite different from the above, and would be obliged to you for a statement of your practice, together with your objections to the foregoing (if any), believing it will prove beneficial, as well as interesting, to many other of your southern readers. The southern man believes that the butter can not be gotten out of sweet milk until it makes that seemingly inevitable *evolution*. (?)

"Can you tell me why butter is always *white*, and light in weight, after the churn has sat too long by the fire?"

The practice described seems to be a cross between that of churning cream and that of churning whole milk. What it is hoped to gain by adding fresh milk to the cream, I do not exactly see, unless it is to increase the quantity of the buttermilk, retard the churning, and give the butter more firmness and more thorough washing in buttermilk, to free it from particles of curd. It would hardly be fair to the many old readers of these papers to repeat the details of our process of making butter. They are quite fully described in earlier numbers of this series. It is not exactly gracious work to find fault with the prevailing systems of any region, but it seems to me that it would be much easier to bring cream to the proper temperature by standing a metallic vessel containing it in warm water, than to heat it through the non-conducting substance of a churn; that the only beneficial effect of adding milk as described, would be equally well gained by adding sour milk, or skimmed milk of previous days—probably, in the case described, the churning of the cream of the fresh milk added is less complete than that of the older cream, a different length of time being required for its development; many persons claim a great advantage from the souring of the cream, others are equally strenuous for churning it fresh. So far as I have been able to see, the evidence is about equally divided, the opinion being generally in favor of more delicacy of taste in the sweet churning. I have never tried churning sweet milk; Col. Weld stated recently in the *Country Gentleman* that he had tested the milk of a certain cow by churning it immediately after it was drawn, and obtained a very large product of butter. It is our own practice to churn our cream sweet, and we are satisfied with the result in all respects.

The whiteness and frothiness of butter made from overheated cream, is probably due to some change effected in the casein of the milk by overheating, which prevents it being properly separated from the butter, the product being really a mixture of butter and cheese.

Flowing Water in House and Barn.

The economy of a full supply of water flowing fresh from the spring, without the labor of pumping, is only equalled by its luxury. No man ever knows how to estimate either the luxury or the economy of the thing, until it is

with him a matter of experience, after this, it becomes well nigh one of the *necessities* of life. Among the various contrivances for raising water to elevated positions, whence it may be conducted about the house, and to the barns and stock-yards, the Automatic Windmill Pump of the Hartford Pump Co., is notable for its simplicity and convenience, as well as for the ingenuity evinced in its construction, and the application of well-known principles. The reverse of the principle by which we suck cider through a straw, may be said to be shown, when by blowing air into a tight vessel filled with liquid, having an open tube descending to near the bottom, we force the liquid to spout out through the tube. This is illustrated in figure 1. A barrel, containing water, has a tube passing through the top, and going below the water. Now if we pump air in by means of an air-pump, we shall pump water out. If the barrel be submerged in a well, and has a valve in the bottom, when it is emptied of water, turning a cock in the air-pipe, to let the air escape, it will be filled with water again. Thus we might, by pumping air into a well, obtain a regular supply of water. The pump which we describe, works precisely upon this simple principle. Chambers are placed in the well or spring—anywhere under water—a windmill works an air-pump, and the water

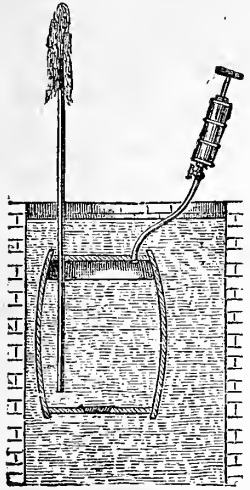

Fig. 1.

there is no perceptible break in the flow. To accomplish this, the chambers are balanced upon a frame having a motion of two or three inches, and the buoyancy of the one filled with air is sufficient to turn a cock, which both conducts the air to the opposite chamber, and lets that which itself contains, blow off, as the water from without rushes in.

When we come to examine this interesting contrivance, we see that after all it differs less than one might suppose, from some common forms of pumps. For instance, in the old-fashioned fire-engines, see figure 2, we have two cylinders, working alternately. These are filled from below, and the water passes out from below, in the same manner, as it does in the Automatic Pump. The pressure, which forces the water out, is however, as in nearly all other pumps, applied by means of a tight-fitting piston, with its piston-rod, joints, diagonal pressure, etc., all of which involves of necessity a great degree of friction. In this pump, the air pressing upon the surface of the water, is piston, piston-rod, and all, working without a perceptible amount of friction—one may say, none at all, and with a force which has only its *economical* limits. Practically 100 to 125 feet is as high as it is desirable to force the water *at one lift*, but with a succession of pumps, this lifting may be indefinitely repeated.

The friction, or loss of power, in the slow passage of air through tubes, is exceedingly small, unless indeed the pressure be very great, and the tube small, in which case, however, the air will move very rapidly. Practically it is found that there is no perceptible loss of power, when quarter and three-eighths inch lead or iron pipes are used to conduct the air. This makes it practicable to place the wind-wheel at any desired distance from the well or spring, even a quarter or half a mile away, if a suitable position for it can not be found nearer. This

flowing water wherever needed. A fine spring is near, but below the house. The windmill, condensing the air, is upon the barn in the middle background. The air is conducted underground to the spring in which the pump is set. The apparatus by which the air-cock is regulated, is seen level with the top of the ground. The water-pipe goes from the spring directly to a tank in the attic of the dwelling, where, by means of a floating ball, the flow of water is

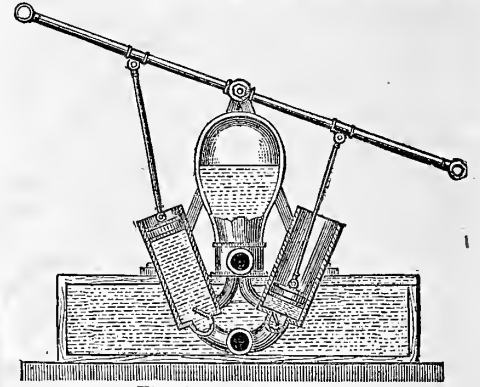

Fig. 2.—FIRE ENGINE.

shut off as soon as the tank is full. From the tank the water is distributed to the bath and wash-room on the second floor, to wash basins in the main part of the house, to the kitchen, and to the laundry. Thence a pipe is carried to the barn, within which a penstock and trough for the horses are set, and to the cattle yard, where another trough is placed; then either the waste water, or an independent pipe, is carried to the garden, where tubs for watering are located, or a constant flow for irrigation is maintained.

This may seem at first a great deal for one little windmill, six or seven feet in diameter, to accomplish, but from the statements made to us, we do not think it beyond credence. Besides, it should be said that whenever the tank is full, and water can be spared, a fountain may be kept playing, if the wind blows; the water coming either directly from the spring, or the waste water from the overflow of the tank being employed.

In addition to the regular daily needs for which water is used, the security against fire is very great, and a hose and nozzle should always be provided for this purpose, as well as for convenience in washing windows at the house, and carriages at the barn.

Whenever water-tanks are set for any purpose, they should be large enough to contain several days' supply of water. No ordinary family uses over 300 to 500 gallons a day. This the smallest sized apparatus is claimed to furnish, and is an abundance for all the purposes indicated in the picture, unless the stock of cattle and horses be large, or wasteful extravagance prevail. The absolutely silent working of the apparatus is a great point in its favor, as well as the fact that, though the windmill is not "self-regulating" in the ordinary acceptance of that term, it nevertheless is so strongly made that the most violent storms, except such perhaps as might unroof the barn upon

which it stands, have no other effect upon it than to make it pump the more. No rapidity of pumping can cause it to suck up gravel and so derange the pump, as windmill pumps so often do. It is necessary to oil it once a month, and this is literally all the attention it requires.

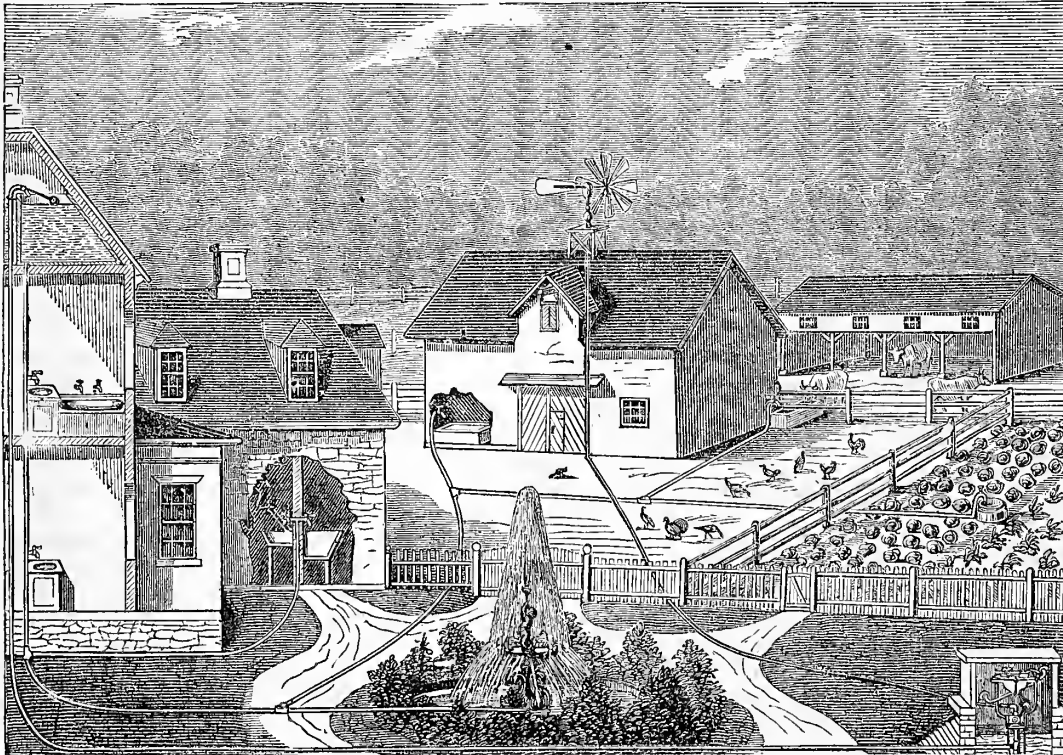

Fig. 3.—THE HARTFORD PUMP CO.'S WINDMILL AND PUMP SUPPLYING HOUSE, BARN, ETC.

may be raised to any desired height. In order to maintain a constant stream, two chambers are employed, and thus, when one is exhausted, that, is filled with air; by a simple contrivance the air is conducted to the full chamber, and the first quickly refills itself with water, so that

is a decided advantage, as springs are usually situated in valleys, where a windmill could hardly be placed to work with power and regularity, unless perhaps upon a lofty tower.

The large engraving, figure 3, represents a country place, which has all the benefits of

How to Stock Ponds with Black Bass.

Great progress has been made in the last five years in the distribution of the Black Bass, especially in New York and in the New England States. Two hundred or more ponds and lakes have been stocked, and yet we are continually receiving letters of inquiry, which show that people have very imperfect information in regard to the habits of the fish, and the best method of introducing them. Some inquire for the spawn, supposing that they are propagated like the Salmonidae. But all attempts to take spawn from this fish have been failures, so far as we are informed. Some ponds have been stocked with the fry, but it remains to be seen whether this will prove successful. The fry are very small, and remain but a few days over the beds where they are hatched, so that it requires very close watching to capture them. They are removed just at the time when they are said to have the protection of the parent fish, and they are all liable to perish in new water among other species of fish. The common and the most reliable method of introducing the bass, is to transport adult fish from well-stocked ponds to new localities. This, when properly done, has never been known to fail. In most of the States there is legal protection to the fish for three years, generally granted by special act of the legislature. But this is not long enough to secure the object. It should be in all cases five years. The fish do not bite freely until after the spawning is over in May and June, and they do not usually reach their new home until July or later, so that there is no fry from them until the second year. The fish generally selected for transfer are from one to three years old, measuring from 3 to 12 inches in length. Fish of this size are not only more numerous, but they bear transportation better, and are more readily acclimated, than when larger. They are moved with a good deal of difficulty in hot weather, especially when the journey requires more than twelve or fifteen hours. With the most skillful management, there will be a considerable loss. In the fall months there is much less loss.

There is a great want of information in regard to the character of the water suitable to this fish. We have many letters from the owners of horse-ponds, a half acre or less in extent, having neither springs nor water running through them for a portion of the year. The bass wants clear lively water with rocky or gravelly bottom, and the more of it the bet-

ter. It wants room for itself and for the poorer kinds of fish upon which it feeds voraciously. It does well in the mill-ponds upon manufacturing streams, and if the head waters and reservoirs are stocked, they will in a few years be found in all the waters below. They flourish also in natural ponds of twenty acres or more. Some decline to stock these ponds or lakes because they are generally free to the public. But this is short sighted policy. A large pond or lake stocked at a cost of one or

such progress in the Eastern States, that an order for trout, or bass, is about as readily filled as an order for Jerseys or Cotswolds.

The Beisa Antelope.

The Antelopes are a numerous family. Their principal characteristic is the cylindrical and annulated form of their horns, which in the antelopes are never angular or ridged longitudinally. The various species comprise animals which greatly differ in size; one species, which is the smallest of all horned creatures, being no larger than a hare; others stand from 3½ to 4 feet in height at the shoulders, and weigh some 800 to 900 pounds. One species inhabits our Western plains, the Prong-horn Antelope, which is perhaps the most elegant and graceful of all our wild animals. Our illustration represents one of the many species which are peculiar to Africa, and is known to naturalists as the *Oryx Beisa*. It is only since the English invasion of Abyssinia, that the animal has been observed by naturalists, and until recently no living individual had been captured. A specimen has within a short time been added to the magnificent collection of the Zoological Gardens of Regents Park, London, of which our illustration—is a portrait from life.

The Beisa Antelope differs from a well known, closely allied species, the *Leucoryx* of Northern Africa, in having straight horns, and by its peculiar markings. It is of a cream color, with black bands upon the face and legs. Its length of face is 17 inches, from its ears to the root of the tail it measures 4 feet



THE BEISA ANTELOPE.—(*Oryx Beisa*.)

two hundred dollars, and protected by law for five years, will furnish better sport to the gentlemen or company who undertake the enterprise than they could find in any small pond of their own. In suitable water black bass multiply very fast, and after they once gain possession, their numbers can never be very seriously reduced by hook fishing. The annual spawning will more than keep up the supply. There are thousands of ponds and lakes in the Northern and Middle States of from one hundred to a thousand acres, producing only the poorer kinds of fish, that might easily be stocked with bass, and add largely to the food supply of the people. It only needs the effort of a few individuals in any neighborhood or township to accomplish this good work. When the funds are raised, there is little difficulty in procuring the fish. Fish culture has made

7 inches, the tail is 26 inches in length, including the brush, which measures 11 inches. The height at the shoulders is 3 feet 7 inches, and the length of the horns is 2 feet 6 inches. The courage and strength of this graceful beast is such, that it readily attacks, and frequently vanquishes and kills the lion, and, when wounded, it charges the hunter with great fierceness. These animals feed upon coarse grasses, and occasionally browse upon the shoots of acacias and other trees. They feed in the morning and evening only, and drink at mid-day. They run in herds of ten and less in number, although single animals are occasionally met with. They are exceedingly cautious and wary, and can only be approached with difficulty. By the capture of this rare animal the natural history of Africa, of which we have so much yet to learn, has been enriched in a notable degree.

Walks and Talks on the Farm.—No. 130.

It is hard work for the horses to break up sod land during the dry weather of August and September. But with a good three-horse plow and a good point, the work can be done. And I have an idea that one good plowing in August will pulverize the soil more than two plowings in spring. When I was a boy, my father was summer-fallowing a field of rather heavy clay soil. He had plowed it three times, and cultivated and harrowed it until it was quite loose and mellow. One day he set me to roll it with a heavy three-horse roller. This puzzled me. We had been spending the whole summer in trying to lift up and loosen the soil, and now to be told to go and roll it! "Why, father," said I, "wont the roller press it down again and make it hard?" "Never again make such a remark as that," he said. "A farmer would think you knew nothing about farming. If you roll or trample land when it is wet, it will become hard and bake. But no amount of rolling will make *dry land hard*." I have never forgotten the remark. If you can break up and thoroughly pulverize clayey land seven, eight or nine inches deep during our dry hot summer months, it will not forget it for years. I think there can be no doubt on this point. The only question is how to do the work.

The field that I "fall-fallowed" in 1868, I sowed to barley in 1869, sowing it to wheat after the barley was off in the fall, and seeding it down to clover in the spring. The clover failed, and I manured the field in the fall and winter, and plowed it up in the spring, and sowed it to oats and peas, and afterwards to wheat, seeding it down with clover in the spring (1872). In 1873 I mowed the clover for hay, and the second crop for seed. This summer I mowed it again for hay. I had a grand crop. After haying, the clover grew rapidly, and I turned in all my sheep and hogs, and ate it down as close as possible. The middle of August I put in the plow. The soil is a strong loam, approaching to clay, and I expected a tough job. We put three strong horses abreast to a good plow, and I went with the man. We staked out the headlands fifteen feet from the fence, and struck out a furrow, going all round the field. I do not know how it is with others, but I find that my plowmen have a natural inclination to leave the headlands to the last, and they like always to turn the furrow towards the fence. The true way, when the land is dry, is to plow the headlands first, and plow all round the field, and turn the furrows from the fence. But to do this, it is necessary to set poles to strike out by. The way we did this is shown in the annexed diagram. We

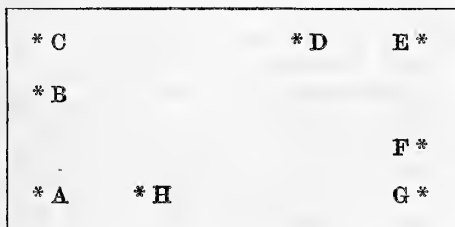

measured fifteen feet from the fence to the pole A, and here we put in the plow, and I went ahead and stuck another stake at B, and another at C, both fifteen feet from the fence. The plowman keeps the stakes B and C in line, and is thus able to strike out a straight furrow. When he got to C, he turned "gee," and struck out a furrow to D and E, and so on to F and G, and then to H and A. We then, of course,

kept on plowing round and round until the whole headland was finished, using only two horses and short whiffletrees to turn the land two or three furrows from the fence.

"There is nothing new in all this," says the Deacon. "I never said there was," I replied. "What we want is not so much new ideas as energy enough to put in practice what we know to be right." I have a set of short whiffletrees that I use for plowing in the garden and for turning the land two or three furrows from the fences. The double tree is only 2½ feet long, and the single trees 14 inches long. I find them very useful. I have also a plow with a movable beam, that can be set so as to turn a good furrow with the near horse walking in the old furrow. In this way we can plow close up to a fence, and turn the soil away from it. Now I do not think there is anything "new" in this. But there are a good many of us who leave two or three feet of land all along the fences to produce nothing but weeds. And if this was all, it would not be so bad. But the roots of these weeds run into the adjoining land, and many a field has become infested with thistles and couch grass from our neglect in the first place to plow close to the fences, and keep our headlands clean. I often see a row of corn planted so close to the unplowed land along a fence, that the cultivator can not be used between the row and the fence. The result is that the row of corn is yellow and sickly, and not worth half the labor that is sometimes spent on it in trying to keep it clean with the hoe, and the land becomes foul. I believe this is the principal reason why my farm was in such a miserably weedy condition. The knolls on the farm are sandy and full of stones. The land could not be half plowed and cultivated on account of these stones. Thistles and other weeds took possession of these stony knolls, and the scratching of the land with the plow, instead of killing the weeds, merely served to scatter the seeds and spread the roots to the land adjacent. The headlands were treated in the same way. The fence corners were a convenient place to put stones, stumps, and rubbish of all kinds. Brambles, elder bushes, burdocks, thistles, and a long catalogue of weeds soon got possession, and not a little of the land on each side was abandoned to them. "I expected to find your farm without a weed on it," said a recent visitor, "but I find you have not succeeded yet in killing all the weeds." I asked for no explanation. I knew very well what he meant. I have contended that weeds *can* be killed. But I never said that I had succeeded in making my farm clean. I have said a great deal on the subject, for the simple reason that the destruction of weeds has occupied much of my time and thoughts. I sometimes get discouraged. It is an unceasing fight. It has to be renewed every year. But I am gaining on them.

Looking at the trouble I have had in killing weeds and in restoring the condition of a run-down farm, it seems strange to me that so many intelligent and well-to-do farmers spend so much time and money in building fine houses and ornamental barns and fences, and so little in draining and in improving the condition of the land. Solomon says: "Prepare thy work without, and make it fit for thyself in the field, and afterwards build thine house." It seems to me that there are a good many farmers who would do well to heed this proverb.

While the Deacon and I were talking and looking at the sheep and pigs, William has been

plowing. Perhaps two of Crozier's Clydesdale horses might plow this land, and turn a furrow 7 inches deep and 10 inches wide. Here we put on three horses, and turn a furrow 15 inches wide. Such a furrow, one mile long, turns over 6,600 square feet, or over one-seventh of an acre. If the horses travel a mile and a half an hour for eight hours, exclusive of turning, they would plow (1.8), say 1¾ acres; if two miles an hour, they would plow in eight hours (2.4), nearly 2½ acres. With a 10-inch furrow, the same distance of travel would plow less than 1½ acre, and a little over 1½ acre respectively. In England an acre is considered a good day's plowing, and three-quarters of an acre is a fair average. When an American talks about plowing two or three acres a day, an English farmer shakes his head. He cannot understand it. And yet if the English horses walk one-third slower, and the plowman works one-third less time, and the plow turns one-third less furrow—if the Englishman plows one acre in the day, the American would plow 3¾ acres!

"I should not think it would make all that difference," said the Deacon. "Figure it out yourself," I replied, "perhaps I have made a mistake, though I think not. At any rate, it is certain that we usually plow much more land in a day, than they do in England and Scotland—probably on an average not far from double. "You are now plowing nearer 18 inches than 15 inches wide, I think I never saw you plow so wide before. You have always advocated narrow furrows." We will not discuss that question now. What I want you to observe, is the splendid condition of this land. It turns up beautifully. It has a rich look about it. It crumbles all to pieces. It has not forgotten that fall-fallowing we gave it six years ago, nor the top-dressing of manure in the fall and winter of 1870.

The Deacon and some other farmers thought I should lose half the value of the manure, by spreading it on the surface. They thought it should be plowed in. They have great faith in the mechanical action of manure. They think it lightens the soil. There is some truth in this, but I have more faith in underdraining, good and repeated plowings, and thorough cultivation, in connection with rich, well decomposed manure.

"Yesterday," said the Deacon, "a farmer took a load of clover hay to Rochester, and all he could get for it was \$10 per ton. Another farmer took a load of wheat straw, and sold it readily for \$12 per ton. This does not look as though farmers had much faith in your chemical notion, that the manure from a ton of clover hay is worth three times as much as from a ton of straw. The facts seem to be against you." "So much the worse for the facts," I replied. "But I am not going to argue that matter with you. There are some things so well established, that it is no use listening to the objections of those who do not understand what they are talking about. A farmer who sells clover hay at the above prices, and keeps his straw, is not a wise man. When he can exchange a ton of straw for half a ton of bran, he had better do it."

"You pretend to be able to tell," said the Deacon, "what a ton of manure is worth, but I notice that the chemists differ very much among themselves, as to the value of the same identical manure, and I do not see how you can tell with any certainty how much good a ton of manure will do." No one pretends to do so.

What we say is this: Here are two samples of baru-yard manure in about the same condition. One contains twice as much nitrogen, phosphoric acid, and potash, as the other, and we say, if the one is worth \$1 per ton, the other is worth \$2 per ton. We do not say that if you put 20 tons of the former, or 10 tons of the latter upon an acre of land, the difference of the crops will be worth \$20. This may or may not be the case. The chemist's estimate of the value of different manures is based on their chemical composition, and on the condition of the ingredients. The chemist does not undertake to tell a farmer, whether he can afford to buy sulphate of ammonia, or nitrate of soda, to sow on his wheat or barley crop. But if you are going to sow these manures, the chemist can tell you to a certainty which of two samples is the cheapest for you to buy. For instance, he finds one sample contains 22 per cent of ammonia, and the other 18 per cent. If he tells you the latter is worth \$72 per ton, and the former \$88 per ton, he merely uses these figures in a comparative sense. If he should say the one was worth \$36, and the other \$44, he would be equally correct. He has nothing to do with the commercial value on the one hand, or the fertilizing value on the other. The latter must be determined by the experience of farmers themselves, and on repeated experiments. Where wheat is worth only 75 cents per bushel, and other crops on the same scale, ammonia is only worth half as much to a farmer, as in a section where wheat is worth \$1.50 per bushel. When an agent for some artificial fertilizer shows me a whole string of testimonials, as to the value of his fertilizer, I tell him that a good analysis would be more satisfactory to me, than an actual trial on my own land and under my own eye. A man need not swallow a lot of Glauber salts to tell if they are pure. The chemist can not tell him whether he needs a dose of the salts, but he can tell him whether the salts are genuine or not. Chemistry can not tell us whether our land needs this or that manure, but it can tell us whether the manure is genuine or spurious. If farmers had clearer views on this subject, the sale of inferior or worthless fertilizers would soon cease.

At the present price of corn, fine middlings, and pork, there is more profit in feeding pigs in this section, than we have enjoyed for some years. Furthermore, lard is in good demand, and packers discriminate in favor of fine boned well-fed hogs. In Chicago, "grassers" are quoted at 5 cents per pound, and dull of sale, while an extra, choice, well bred and well fattened pig, would bring 8 cents live weight. This is as it should be. The latter, even at this greater difference in the price, is far cheaper to the consumer than the former. And it makes quite a difference to a farmer, whether he has fifty "grassers" weighing 175 lbs. each to sell at 5c. per lb., or fifty choice, well bred and well fed pigs, at the same age, that will average 300 lbs. at 8c. The former lot will bring \$437.50, and the latter \$1,200.00. We ought to produce the best pork, lard, and hams in the world, and secure the highest prices in the English market. Instead of this, Irish hams are quoted in London, at 22 to 24 cents per lb., and American hams at 13 to 15 cents. And there is a corresponding difference in the price of pork. I asked Mr. DeVoe, our largest pork packer, what was the reason American pork sold so low in Europe. "Vot is the reason," he exclaimed, "I will tell you why. Ve

think they are vools over there. Ve think anything is good enough for them. Pork that ve would not eat here ve ship to Europe. I sent several barrels of pork as a present to my friends in Germany, and they said it vas most excellent, but that most of the American pork they got vas vile stuff. The Captain of a steamer running from Hamburg to New York, vonce gave his crew American pork on their return voyage. Great vas the grumbling. And ven they got to Hamburg they refused to continue on the ship until the captain had given them a written agreement, to never again give them American pork!"

A large grocer and provision dealer in Staffordshire, once told me that he bought a quantity of Ohio bacon, and retailed it out at a good profit, and with much satisfaction to his customers. The next lot he bought was so poor that he could not dispose of it. "Since then," he said, "I have been afraid to deal in the article. If it was always as good as that first lot, I could sell large quantities." For many years we had the same state of things in regard to American cheese. Our cheese factories, however, are now making so good an article, and there is so much greater uniformity in the quality, that American cheese, I believe, commands as high a price as the best Cheshire. It will in time be so with American pork, bacon, hams and lard.

As a rule, the price of agricultural products in Europe determines the price in America. Hitherto the cost of labor here has been double and treble what it was in Europe. Our products had to compete with the products of this cheap labor, and pay freights over long distances into the bargain. We have been able to compete, because we lived economically and worked hard, and because our land was cheap and comparatively rich in what I have called "natural manure." We have grown cheap wheat and corn on our new land, because we have to pay no "rent," and because every bushel of wheat we have grown has found an amount of manure in the soil, which would have cost the English farmer at least 50 cents. We are now getting less and less of this natural manure. We find an increasing necessity for furnishing manure to our land. We should now find it a hard matter to compete with the English and European farmers, if they could get labor at the old rates. But fortunately for us, and fortunately, as I think, for them and all concerned, labor is now nearly or quite as high there as here. This places American farmers on a far better footing than ever before. Owning instead of renting our land, with a favorable climate, a rapidly increasing population, improved implements, and comparatively intelligent and skilled labor, we have good reason to take courage and push ahead with our improvements.

ENFORCE THE DOG-LAWS.—Sheep raising is undoubtedly looking up. Wool brings satisfactory prices. Early lambs are in brisk demand, and the market would take a great many more. We can have mutton, at least in winter, and farmers look cheerful in view of the profits of the flock at the close of the year. The pastures, where the sheep have been, are blooming with white clover, and the increase of grass and the reduction of brush are strong points in favor of sheep husbandry. But the dogs still worry the flocks, and kill sheep, notwithstanding the legislation against them. Some of the States have good laws for the pro-

tection of sheep. The owners of dogs have to pay a license for every cur they keep, and the money goes into a fund to pay for the losses of sheep owners made by dogs. This is a great security. It not only reduces the number of dogs, but pays for the damage they do. What is now most wanted is the strict enforcement of the law where one exists. Make every man pay for his dog, and kill the unlicensed.

Wheat without Manure.

Our readers have been frequently advised of what has been done by Mr. Lawes of England, in the way of raising repeated crops of grain upon the same land year after year, both without and with manure. But Mr. Lawes' labors have been experimental. We have now before us a report of the sales of the standing crops of wheat, oats, and clover upon two farms in England, upon which these crops have been raised successfully for a dozen years, and sold standing, to be cut and carted away by the purchasers, both straw and grain together. No stock is kept upon these farms. No manure is used upon them. Deep plowing by steam, and draining to further deepen the soil, are the only means by which these crops are produced year after year. One of these farms is owned and cultivated by Mr. Prout, of Sawbridge-worth, and consists of 450 acres. The present season's crop was chiefly wheat, which, sold by the acre as it stood, realized from \$45 to \$89 per acre, for grain and straw. The purchaser in all cases does the harvesting. The average prices were, for wheat, \$54.40 per acre; oats, \$49 per acre; and clover, \$52 per acre. The whole proceeds of the 450 acres were \$23,141, an average of \$53.30 per acre. The average result of the past seven years' crops has been \$51.25 per acre. The farm was purchased twelve years ago, and was then in poor condition. It was drained, and \$4,000 worth of chemical fertilizers were used, to bring it into a producing state. Since then it has been cultivated deeply by steam each year, but no fertilizer has been used, nor has the straw even been retained upon the farm. The other farm is owned by Mr. Middleditch, of Wiltshire. It has been managed upon the same plan. The crops upon this farm brought from \$18 to \$36 per acre, or an average of \$55. The aftermath of some fields of sanfoin, which were to be pastured by sheep, sold for \$10 to \$18 per acre. There are 500 acres in this farm. Both farms have a clay soil, and are fairly good wheat lands, but at the commencement of this cropping were much run down. The farmers who purchased the crops, and some who had taken them for several years, said that those of the present year were the best crops for several years, and Mr. Prout expressed the opinion that he could thus farm "as long as he lived, and his son after him." We do not pretend to make any application of this anomalous kind of farming, but merely give the facts. At the same time we can not refrain from comparing it with some farms we have seen, in the rich valleys of Ohio and westward, where for twenty years the merest scratching of the deep, rich soil, and the raising of wheat upon the unplowed corn-stubble, year after year, has made farmers comfortable, if not rich, and thinking at the same time, that it is possible, if those rich lands were better treated, and farmed more with the plow, and less with the harrow, that they might produce better crops than they now do, and remain profitable to their owners for an indefinite number of years to come.

Ice-House and Cool-Chamber.

The principal requisites for an ice-house with a cool chamber below it for milk or fruit are, a locality where the ice can be conveniently placed in the upper part, and where there is drainage to carry off the waste from the ice. A hill-side is the most convenient position for such a house.

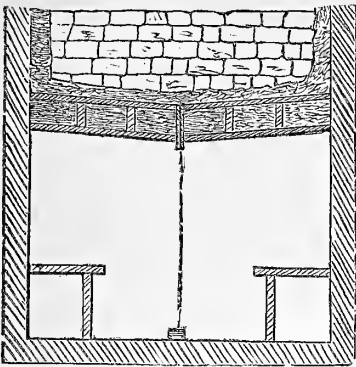

Fig. 1.—INTERIOR OF COOL-CHAMBER.

The method of construction is the same as for any other ice-house, excepting in the floor. The walls are double, and are filled in between them with sawdust or other non-conducting material. The roof should be wide in the eaves so as to shade the walls as much as possible, and it will be found convenient to have a porch around the building, on a level with the floor of the ice-house.

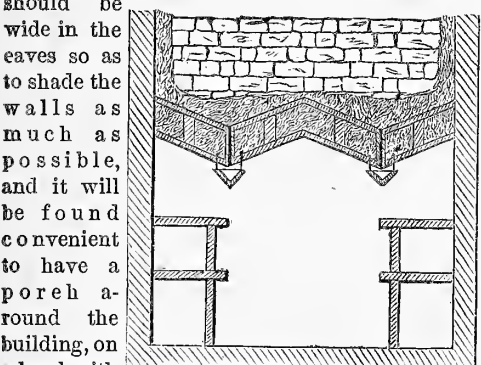

Fig. 2.—MR. RANKIN'S COOL-ROOM.

The floor of the ice-house must be made not only water-tight, but airtight. If a current of air can by any means be established through the floor of the house, the ice will melt away in a very short time. A double floor of matched boards tarred at the joints, and between the floors, should be laid. The joists are placed so that the floor

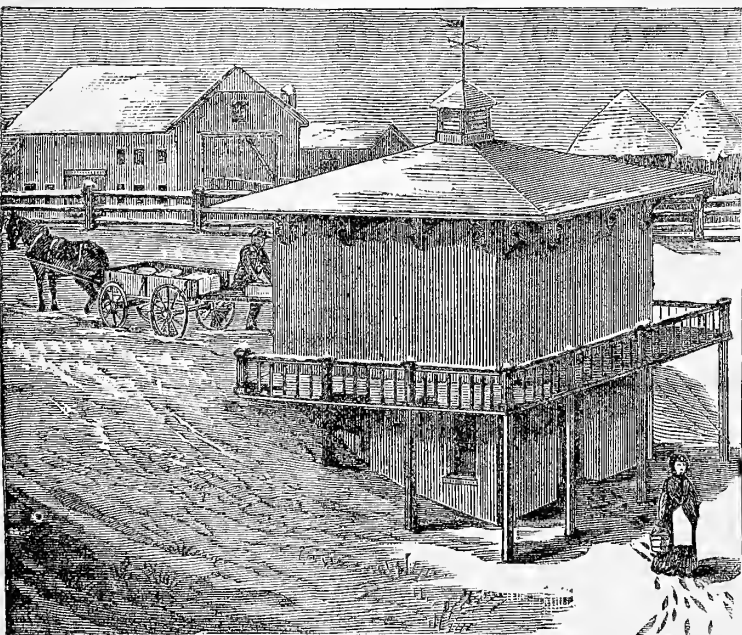

Fig. 3.—ELEVATION OF ICE-HOUSE.

slopes from both sides to the center, to collect the waste water from the ice; a channel is made along the center to carry it to the side of the building, where it is made to pass off by means

of a pipe with an S curve in it, to prevent access of air. Or the pipe may be brought down through the lower chamber, and made to discharge into a cistern, in which the water is kept always a few inches above the level at which it is discharged from the pipe. The method of this arrangement of the floor is shown at fig. 1, which represents a section through the floor and lower chamber, in which the shelves are seen. Fig. 2 shows the patented arrangement of Mr. Rankin, of Denison, Texas, and Emporia, Kansas, which he has adapted to the refrigerator cars, in which fresh beef is brought from Texas to the Eastern markets. Although this is patented, Mr. Rankin makes no charge for the use of it, except the nominal one of one dollar for each ice-house, and it is therefore practically public property. The ceiling of the lower chamber is made to slope, as shown in fig. 2, and may be covered with sheet zinc. Above the ceiling there is the usual non-conducting layer, and a floor sustained by the usual joists upon which the ice is packed. The coldness of the ceiling causes the moisture of the lower room to condense upon it. This moisture runs down the slope, and drops into troughs or gutters of zinc, which are suspended beneath it. From these it is carried off into the cistern, which collects the waste water from the ice above.

Such cool chambers as either of these may be used to preserve fruit, meat, vegetables, or other perishable matters. Some ventilation and circulation of air in them is necessary to prevent mould or mildew, and it would be preferable to build the lower story of brick or stone rather than of wood. The upper part of the building could be built of wood as well as of any other material. A temperature of 40 degrees has been maintained in such a chamber throughout the summer, but this can only be done where the soil is very dry and gravelly. The elevation of the building is shown in fig. 3.

A Large Underground Cistern.

The supply of water needed for a stock farm is very large. One large cistern may be built for much less than several small ones of no greater total capacity.

A correspondent sends us a description of his cistern, which holds nearly 30,000 gallons, or over 700 barrels of water. This cistern, which we here illustrate, is 20 feet in diameter, and 12 feet deep. It is lined with brick set in cement, and is arched with brick, and covered with earth to keep the water cool. That the spread in the arch may be reduced, there is a brick column in the center from which the arch is made to spring all around. The engraving shows

a section through the middle of the cistern, with the pillar in the center of it. The central pillar needs to be well and substantially built, as it supports half the weight of the arch and

covering. It should be at least two and a half bricks thick, and square. The cistern here represented, is situated upon the highest ground of the farm, and is supplied from a well by means of a windmill and force pump. The

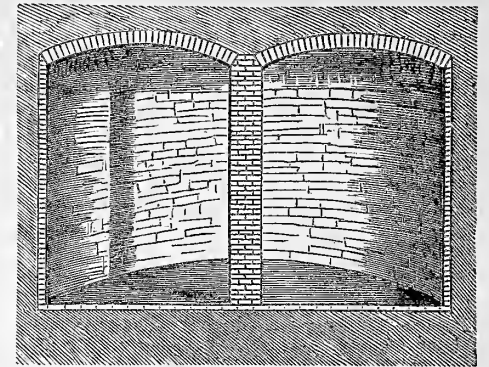

SECTION OF CISTERN.

water is brought in pipes by its own gravity, to the house, stables, and garden, and in seasons of drouth is used to irrigate the garden. There are many conveniences in all this, which make it a very desirable cistern, and its real value on a farm is much greater than its cost.

A Safe Tether, or Picket Pin.

The disuse of fences either in whole or in part, renders a secure method of tethering an animal of great use. Stakes are easily loosened or battered to pieces by driving them, and the tethering rope is frequently wound around them. If a strong iron rod be bent into the shape of a corkscrew, with a loop at the upper end, it may be screwed into the ground, and will then hold the strongest animal safely, while the rope cannot be wound around it. This implement will also answer the purpose of a post to hold guy ropes for shears, or any other similar purpose, or to fasten the lower block of hay hoisting tackle, when working with the hay fork. Indeed there are many uses for this little contrivance, which will suggest themselves. The illustration represents it as fixed in the ground. One of its advantages, and not the least of them, is that it is readily set in place, and as readily removed, without the

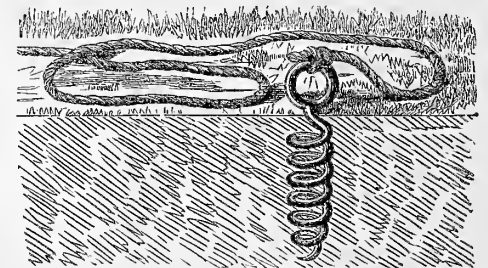

A SPIRAL TETHER-PIN.

use of a hammer to drive it or knock it loose. A short stout stick like an auger handle put through the loop, is all that is needed.

The Barn Sheet.

The Barn Sheet is a very useful thing to have in every barn. Every harvest it will save more than its cost in grain, that would otherwise be scattered upon the field or the barn floor, and go to waste. When loading oats or buckwheat especially, the saving of shelled grain, by having the sheet in the bottom of the wagon, is often equal to the amount of the seed. It is also useful to spread over a load of hay or grain that may be caught in a sudden shower, or over

a half finished stack. It will serve to cover up a carriage and preserve it from dust. Many other uses will suggest themselves to the careful farmer who has provided himself with one. It may be made of four widths of yard wide stout sheeting, four yards long, strongly sown together with linen thread, and with a strong cord bound into the outside hem. It would be better to have a coat of linseed oil, which would make it nearly water-proof, but without this, if placed over a stack, the top of which is well rounded up, it will turn a steady rain of 24 hours' duration. The cost of a sheet like this being so insignificant, and its uses so obvious, it should find a place in every barn.

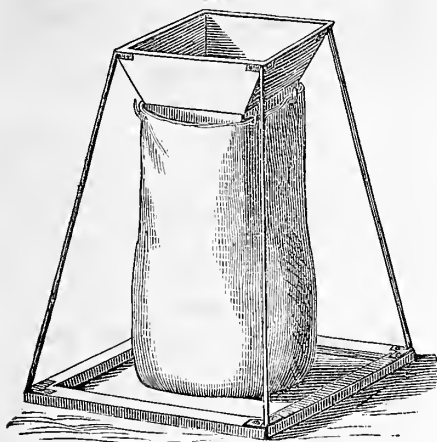

Fig. 1.—STATIONARY BAG HOLDER.

Bag Holders.

Two of these useful contrivances called bag holders are shown in the accompanying engravings. That shown in figure 1 consists of a box with flaring sides, which is made to operate as a spout to receive the grain or whatever is to be poured into the bag. At the bottom of the box a few small hooks are fastened, by which the bag is held. The box is supported by four light iron or wooden rods upon a bottom board. This board may be mounted upon wheels if desirable. Figure 2 shows another style, which may be folded in a small space when not in use. It consists of a bottom board with an upright at one side; a pair of arms are pivoted to the top of the upright. These arms are fastened together by a cross piece, to which a brace is hung by a hinge. This brace is made to sup-

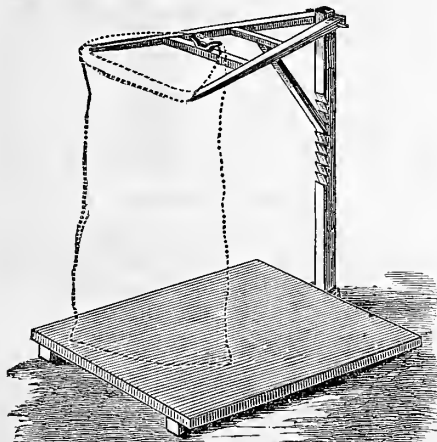

Fig. 2.—ADJUSTABLE BAG HOLDER.

port the arms in a horizontal position, by means of the notches upon the upright post, into which the end is made to fit. A button is also fitted upon the upper side of the cross piece by which the bag is held. To place the bag in the holder the edge is passed over the button and turned

down; it is then turned over the projecting points of the arms, by which it is held securely while being filled. The dotted lines in the engraving show the manner of turning the edge of the bag over these parts of the holder.

Pasturing Cows in Apple Orchards.

In riding through Normandy last autumn—a country filled with orchards—from the apples of which, cider, the universal beverage of the district, is made, the writer saw a great number of cows pasturing on the rich grass under the trees, and eating the fallen apples. Every cow was rigged with a sort of rope harness, to the girth of which was attached a short halter that prevented her raising her head to take apples from the trees. The contrivance was exceedingly simple and cheap, and

there is no reason why it might not be adopted by the farmers in this country who would gladly pasture their orchards except for the damage done to fruit and branches by cows whose heads are free. The halter should be as short as will allow the head to be raised to its natural level; there will then be no danger of its being caught by the foot. This is not only more effective, but much less objectionable than the

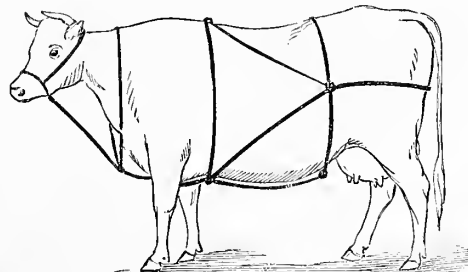

HARNES FOR A COW.

method sometimes practiced with us of tying the halter to one of the forelegs. The cow when harnessed in this manner, walks about, lies down, and rises up, with perfect freedom.

Remedies for Hen Lice.

As the summer heats increase hen lice multiply and the broods need constant looking after. It is a safeguard to put tobacco in the nests of sitting hens. Refuse tobacco or old stems will answer the purpose. If lice are already in the hennery make a strong decoction of tobacco and apply it with a syringe all over the inner surface. Sulphur sprinkled in the nests and about the roosts is also a good remedy. Insects do not like the smell of brimstone. Another remedy much used recently and very easily applied is kerosene oil. Strips of larding from the tailor's shop are tacked upon the roosting poles, and these are saturated with the oil. The hens upon the poles get some of this oil upon their feathers, and wherever it touches it drives off the insects or kills them. Carbolic acid is another cheap destroyer of insect life. It is largely diluted with water and applied to all parts of the house. If, in very old houses, one application is not sufficient, repeat it.

Water Trough for Barn Yard.

In the barn yard at Mount Fordham, we recently saw a water trough for cattle, which we here illustrate. It is calculated to prevent cows from indulging their favorite pastime of hooking or punching their companions, or keeping the weaker members of the herd from the water. The trough which contains the water is enclosed in a circular box, and there

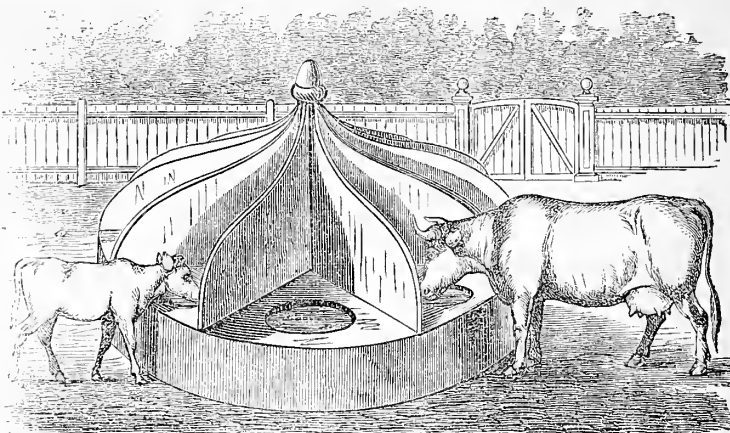

WATER TROUGH FOR BARN YARD.

are several partitions which separate the drinking places from each other. Holes are cut in the upper part of the box through which the cows can drink, and by this contrivance the water is kept clean. Something similar to this has long been in use in our own yard for watering sheep; the great advantage is that the sheep can not crowd each other from the water, or wet their wool, which in winter time is injurious to them.

Fastenings for Barns and Out-Buildings.

"Safe bind, safe find" has reference to barns and stables, as well as houses. It is frequently the case too, that suspicions unjustly aroused would be prevented, if barn, stable, and granary doors were kept securely fastened. A simple, cheap fastening, that is more secure than padlocks, and harder to be picked than locks, is here illustrated. It is one that we have ourselves used upon farm buildings, including pig pens, chicken houses, and corn cribs, and it has the advantage, which is not inconsiderable, that one key opens every door. The key, too, is of such a character, that it is not easily lost, and if it should be lost, it can be readily replaced. The key-hole



Fig. 1.

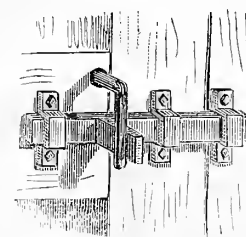

Fig. 2.—BOLT.

is a plain round hole, half an inch in diameter, in the door. The key is a bar of round iron, hinged in the middle, and furnished with a handle, as shown in figure 1. The lock is a simple sliding-bolt, upon which a projecting piece is fastened, as shown in fig. 2. The bolt is shot back and forth by the jointed key, the end of which, when it is inserted into the key-hole, drops down, and catches against the projecting part

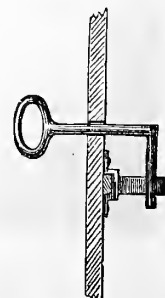

Fig. 3.

of the bolt, as in figure 3. To make the bolt perfectly secure against a dishonest attempt, any secret device or arrangement, to fasten it in its place, may be adopted, such as a wedge or a pin, moved by a string, or every door in a barn, but one, may be fastened inside, and only one left to be fastened from the outside, which will greatly add to the difficulty of entering to any unauthorized person.

For an in-door fastening, to be used in passages where cattle or horses pass and repass, the bolt shown in figure 4 will be found safe and convenient. The sharp projecting part of the bolts in common use, is dangerous to passing animals, but if a round bolt is used, and the projecting part, by which it is slipped back and forth, is made heavy, or long enough, to cause the bolt to turn, and let it drop downward, there is nothing to interfere with the animals or harness in passing. It is one of these little conveniences, which are so small as to be overlooked, but which nevertheless often prevent less or more serious trouble.

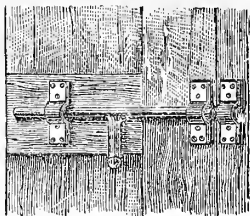

Fig. 4.—BOLT.

Progress in reclaiming Salt Marshes.

We hardly know how to account for the very slow progress made in reclaiming the fertile salt meadows along the sea coast. It was demonstrated nearly twenty years ago, that these marshes can be reclaimed and made to yield large crops of clover, timothy, and red-top, and indeed all farm and garden crops. For the upland grasses they need only to have the sea-water shut off by dikes and tide-gates, and very little surface drainage. Yet, with millions of acres of these meadows along the sea-coast, not one in a thousand has been improved. These lands are generally owned in small parcels by farmers, who oftentimes live at a distance, and value the salt hay for the change of food it gives their cattle in winter. A marsh frequently embraces a thousand or more acres, owned in a hundred or more parcels, and to drain it requires concerted action. This is quite difficult to secure, especially when capital is to be raised to secure the improvement. Farmers are averse to change—slow to believe any thing they do not see with their own eyes. Yet there are some readers and thinkers among them, who are wide awake to improvements, and have faith enough to travel and see what the rest of the world is doing. Numerous small patches on Long Island, and New Jersey, and in New England, have come under our observation, and there are several large tracts in Massachusetts, so completely successful, that capitalists can no longer hesitate to put their money into such enterprises. Among the earliest of these improvements was a marsh of nine acres at Stonington, Conn., diked by the railroad embankment, and furnished with a tide-gate in 1855, with which the old readers of the *Agriculturist* are familiar. Though that reclaimed land has passed into other hands, and the tide-gate is not properly guarded, it still furnishes good pasturage and hay, and is much more productive than the adjacent upland. The marsh of James A. Bill, in Lyme, on the banks of the Connecticut River, yielded luxuriant crops of hay for many years, and was finally changed to a cranberry bog. No case of

failure, when the tide-gate has been kept in repair, has come under our observation. A new interest is awakened in Massachusetts by the great success in reclaiming the large Marshfield marsh of 1,400 acres. The sea-water was first shut out in November, 1872—after years of talk, labor, and persecution, such as the pioneers in such a work alone can appreciate. The barrenness, ruin, and disaster that were predicted have not taken place. Instead, there has been an increased growth of the grasses that have sprung up among the waning salt-grasses. The yield of hay surpasses all expectation, and it is of excellent quality, far superior to salt-hay. As yet there is no well digested plan for introducing the upland grasses. In an experimental way, small patches of timothy, red-top, and clover have been sown on the surface without any preparation. The marsh has not been plowed, and this will not be necessary to stock it with these grasses. The salt-marsh sod is like a sponge, and grass seed catches upon it quite as readily as upon prepared upland. There are isolated patches of red-top that will probably cut three tons to the acre this season. Red-top seems to be admirably adapted to these reclaimed lands. Other grasses do well so far as they have been experimented with. The coarse salt-grasses near the creek are nearly all dead, and will soon disappear entirely. The experiment is a complete success, and the mouths of the gainsayers are effectually stopped. Grass four feet long, and timothy plumes five and six inches in length are arguments not easily answered. The estimates of the value of these lands made in the *Agriculturist* twenty years ago are fully realized. In many of the older States there is no more promising field of investment in agricultural improvement than in these salt marshes.

A Home-Made Brush.

By and by the time for slaughtering hogs will arrive, and a great many bristles will be thrown

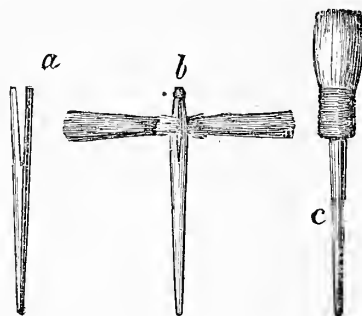

MAKING A BRUSH.

away and wasted. The following plan of utilizing them is sent to us by a correspondent. Take a piece of strong wood, and shape it like a brush handle, and split it at the thick end with a fine saw, as at *a* in the engraving. Place the bristles with their butt ends in the split on both sides. Tie the end of the split stick with waxed twine, and fasten it, (see *b*). Then turn down the bristles, and wrap them with waxed twine firmly and smoothly, making a brush, (see *c*) that will answer all the uses of a purchased paint brush upon the farm or around the house.

A CALIFORNIA FARM.—A farm in California has lately been rented for \$40,000 per annum. It consists of 20,000 acres, and is stocked with 1,900 head of cattle, 100 horses, 50 mules, and 1,500 hogs. The lessee purchased

the stock and the standing crops for the sum of \$74,250. This farm is all arable land. The possession of large tracts of land under old Mexican grants, makes this extensive farming possible in California. How long it will last under the system of agriculture prevalent in that State, is a question. Such a farm is an anomaly in American farming, and we believe the like can be met with in no other State.

Drill Sowing Wheat.

Every year's experience is in favor of drilling wheat. It shows more and more that, as against sowing the seed broadcast, it is economical in labor and in seed, and gives a better crop. The difference in labor is at least \$1.00 an acre, or the cost of two harrowings after sowing, or one cultivating. The difference in seed is at least half a bushel, or 50 cts., to \$1.00 an acre, and the difference in the crop is fully one-fourth, or upon fairly good soil, six bushels or nine dollars per acre. Eleven dollars per acre upon ten acres, will more than pay for the best drill made, which will sow ten acres a day. But if the means of purchasing a drill are not available, and there are less than ten acres of wheat to be sown, it will yet pay to hire a drill, which may be done from some neighbor, fortunate enough to possess one, for 50 cents per acre. We have not yet seen a part of the country, where a drill could not be purchased or hired, and very few fields upon which a drill could not be used, if the ground was properly prepared. It is one of the greatest advantages resulting from the use of machinery upon farms, that it to a great extent necessitates good farming. At least that it compels improvements, and the farmer who once enters upon the march of improvement, rarely stops and never turns back. Thus when a drill is used for the first time, the farmer finds his crooked fence in the way; his narrow gates, or his awkward bars are inconvenient, the brush and weeds around his fence interfere, his poor plowing is troublesome, the banks and hard spots that have been left, a nuisance to him, and the weeds, trash, rough clods, and stones upon the surface, are a severe tax upon his patience. The next season all these faults will be remedied, because discovering the profit of the machine, he is obliged to prepare for its use. This is like the entrance of light into dark places, and a number of things that were never noticed or suspected before, are now so conspicuously apparent, that they cannot be any longer left undone. The same is true as to the use of the mower or the reaper, and thus the money spent for any of these needful machines, is repaid in more ways than one.

The Position of Windows in Horse Stables.

We find in a German exchange some curious observations on the manner in which the position of the windows in the stable affects the eyes of a horse. In one instance the horses of a farmer,—fine animals, celebrated for their excellent condition, were kept in a stable lighted only by a small window at one side. When light was needed for work, the door was temporarily left open; the result was that nearly all of these animals had eyes of unequal strength, and in time a number of them became blind on the side toward the window. A strong light directly in the horses' faces has been found to weaken the sight. The worst position of all

for a stable window is in front of the horses and much higher than their heads. An officer had bought a perfectly sound mare from a gentleman whose stable was lighted by windows at the rear of the stalls. The animal was sound and perfectly satisfactory. After three months she became suddenly "ground-shy"; on examining her eyes they were found directed upward, and this was explained by the fact that the windows of the officer's stable were situated above the head of the stalls, the eyes being generally drawn in that direction. She was removed to another stable, where the light was admitted from all sides, and in three months time the difficulty had disappeared.

Another officer reports that during the campaign of 1870, in France, he rode a horse that was a capital jumper. On his return from the war, he placed this animal in his stable, the windows of which were above the front of the stalls, and in a short time the horse became so shy of the ground that he had to sell it. He had had a similar experience with other saddle-horses, all of which became ground-shy in his stall. One animal in particular, a thoroughbred mare, renowned for her jumping qualities, refused in a short time to cross the smallest obstacle, and when forced to cross a foot wide gully, made a leap that would have cleared a ditch fourteen feet wide. Owners of horses who find that their animals shy at objects on the ground, or at their side, would do well to look to the windows of their stables for an explanation of the evil.

A Portable Poultry House

A correspondent sends us a plan for a portable poultry house, which can be readily

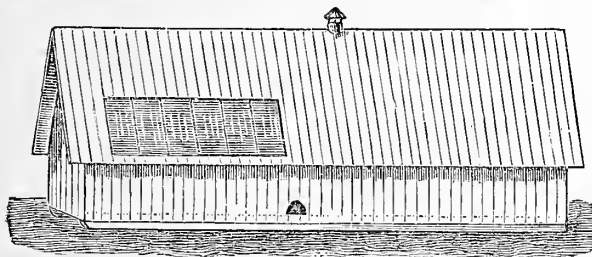

Fig. 1.—ELEVATION OF HOUSE.

moved from place to place. It is shown in figure 1. The size of the building is immaterial, so that it is not made too heavy to be moved by one or two horses. The building is raised upon sills, which are

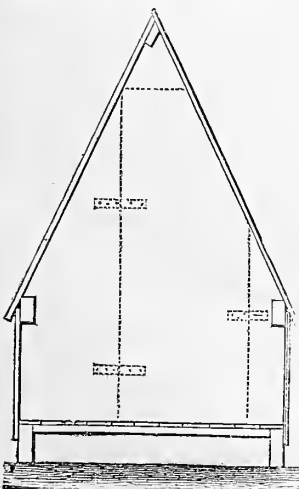

Fig. 2.—END OF HOUSE.

also the method of putting the building together. Figure 3 gives the ground plan. The

nests are seen at *a, a*, the water-fountain is shown at *b*, and the roosts at *c*. Similar portable houses have been found very useful in

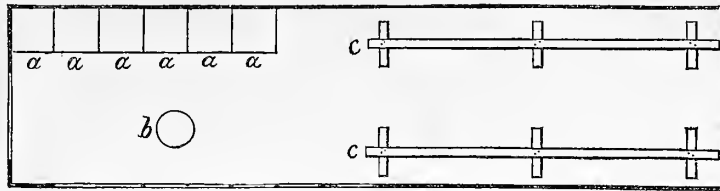

Fig. 3.—PLAN OF INTERIOR OF HOUSE.

many places, where a removal to fresh ground is necessary for the comfort of the fowls.

Prize Farming in Ireland.

The offer of prizes of small pecuniary value for excellency in the management of farms, has been found to have a remarkably good effect in Ireland. Whether or not something of the same kind might have a similar result with us, were our agricultural societies to offer premiums for the best cultivated and improved farms within their jurisdiction, it is of course difficult to say. Doubtless, as a means of greatly benefiting agriculture proper, a portion of the funds of State or County Associations might well be diverted from the fostering of the fast horse interest, and appropriated to this purpose. But whatever might be the result, if it be attempted in this country, it will be instructive to note what has been done in this way to improve the condition of agriculture in Ireland. It is only since the year 1870 that the principles of agriculture have been taught in the public schools of Ireland, and school-farms or gardens have been cultivated in connection with these schools, as practical illustrations of the lessons taught. These have been very successful, and have greatly aided in improving the condition of the small Irish farmers, most of whom, or 317,457 out of 608,864, occupy farms of less annual rental than \$40. As an additional encouragement to improved cultivation and homestead arrangements, the Irish government has given, through the Commissioner of National Education, twenty-four prizes, three for each of eight districts, in which there are school-farms, of the value of \$17.50, \$12.50, and \$7.50 respectively, to be distributed annually, for the next five years. The conditions are simply that the farms shall be of not more than \$40 annual rent, and that the successful competing farms shall be adjudged to excel in neatness and cleanliness of the house; in the amount and quality of the produce of the land; in the character and condition of the stock, which includes all live stock kept for profit, from horses down to bees; and in any other circumstances that may attract favorable notice. A successful competitor can take no more than three prizes in five years, and prizes are not given, unless the farms are sufficiently meritorious, and deserve them. The examinations for the award for the present year have recently been made, and the judges' reports published. From them sufficient can be gathered, to show that the expenditure has been productive of a vast public benefit. On all the farms which competed, the improvements were very remarkable. The educational results were conspicuously shown by the greater money profit derived from the farms, in consequence of their improved management; so that, should

the prizes be withdrawn at once, the benefit would be a permanent one. The homesteads have been fenced in from the public road, and

surrounded with gardens; gates have been hung; calves and pigs of improved blood have been raised; manure has been collected, and composting has increased its quantity and quality, and in the process cleanliness of yards and stables has been inaugurated. In several cases the increased income of the farms in two years has enabled their owners to make deposits in the savings banks, and thrift and economy have generally superseded carelessness and poverty. In one case a woman, who farms 15 acres of land, has won a prize; she was the daughter of a farmer who had died, leaving a dependent family, and had been a pupil at one of the schools where agriculture is taught. Another successful competitor had never before had a field of clover or turrips, but now has adopted a rotation, in which these ameliorating crops occur, and exhibited fields of each in excellent condition. His farm is said to be a model of clean cultivation and productive crops. He has made money by these improvements, and will never abandon them. Another competitor's farm, which last year was very foul with weeds, was found entirely free from them this year. The competition has brought many of these small farmers into popular distinction, and made them men of mark. Some of the farms are visited by other farmers from far and near, much enthusiasm has been awakened, and the spirit of improvement is active and general. While appreciating the difference which exists between farming and farmers in Ireland and in the United States, there is yet ample opportunity here for improvement, similar to that here related, which might be started by a similar agency.

EGG INSPECTION.—The Butter and Cheese Exchange of New York, recently adopted a system of inspecting eggs sent to that market. It has been in operation a sufficient length of time for the results to be ascertained, although it has not yet reached a point where it works with perfection. The chief inspector reports that the system has so far met with the approval of both shippers and dealers. The system adopted is as follows. Each shipment of eggs is sampled on its arrival, by taking five or ten barrels and examining the contents; the average condition is held to represent that of the entire lot. When an unusually bad barrel is discovered it is thrown out, so that it may not unduly reduce the average of the shipment. The discarded barrels are received on their exact merits. The cost of inspection is 75 cts. a barrel, and the advantages are so obvious, that shippers have so far willingly submitted to the cost. One good result is that shippers have already taken greater care in preparing their packages for market, and it will be much to their profit, if every one would judiciously select and carefully pack all the eggs they may ship for sale. Now that one innovation is tolerated in the egg trade, we may hope that the long needed improvement of selling eggs by weight may be considered. Nothing is more absurd than selling eggs by count, as some are twice as heavy and are worth twice as much as others. Weighing the eggs would be more just.

Spring-Houses.

There is no better method of preserving that equable temperature, which is necessary for the best management of a dairy, than the use of a permanent spring of water. In winter and summer the temperature of water, which

The points necessary to look at most particularly in constructing a spring-house are, the coolness of the water, the purity of the air, the preservation of an even temperature during all seasons, and perfect drainage. The first is secured by locating the house near the spring, or by conducting the water through pipes, placed

be covered with wire-gauze, to prevent insects or vermin from entering the house. The house should be smoothly plastered, and frequently whitewashed with lime, and a large ventilator should be made in the ceiling. There should be no wood used in the walls or floors, or water-channels. An even temperature can best

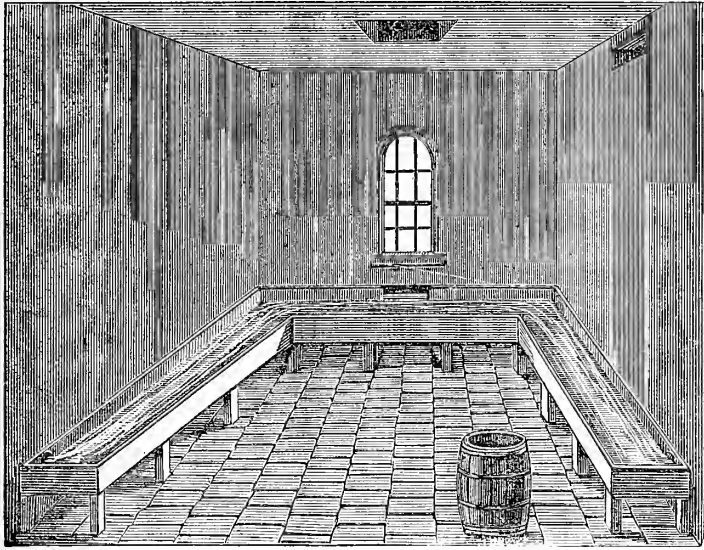

Fig. 1.—INTERIOR OF SPRING-HOUSE, WITH ELEVATED TROUGH.

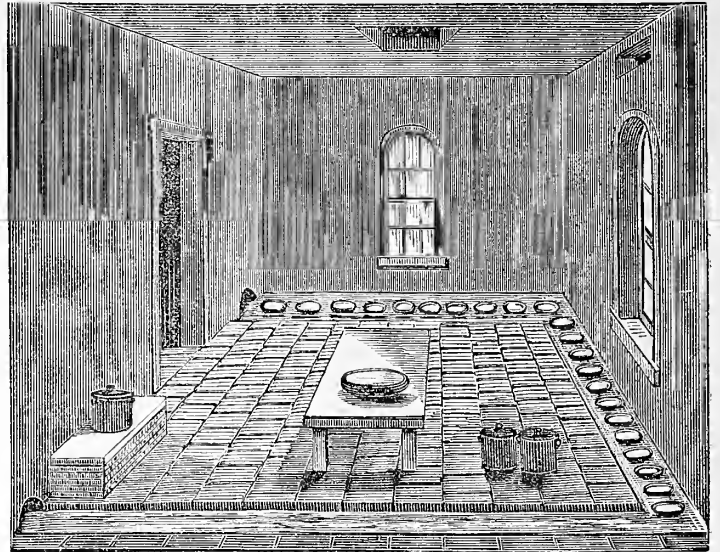

Fig. 2.—INTERIOR OF SPRING-HOUSE, WITH LOW TROUGH.

issues from springs, is constant, or nearly so. The temperature, too, is as nearly as possible that which causes the cream to rise most rapidly and most completely. This is a very important point in butter making, and the excellence of the quality depends upon this probably more than upon any one other circumstance connected with the operation. Besides evenness of temperature, pure air surrounding the milk and cream, is a necessary thing to secure. A stream of pure flowing water insures this in two ways. There is no better absorbent of disagreeable scents than pure water, and the odor of milk, fresh from the cow, is very disagreeable; if it is not got rid of, it remains in the butter and cheese, and may be readily detected in them. This animal odor, as it is called, is volatile, and is easily driven off as the milk cools, if there is a current of fresh air or pure water brought into contact with it. A current of spring water, flowing around the pans of milk, will carry off this odor completely, and in addition to its own absorbent property, it sets in motion, through its lower temperature, the air of the spring-house, and causes currents to pass continually in and out of the house, and over the milk. These currents of air are also full of moisture, and this moisture helps to absorb the odors. At the same time there is no evaporation from the milk or cream, and in a well constructed and well managed spring-house, we never find the cream become dry and leathery, as it may do in dry, airy cellars or milk-rooms. Then there is the perfect cleanliness, which may be secured, where there is an ample supply of pure water, that may be added to the credit of a good spring-house.

at least four feet under ground. The spring should be dug out and cleaned, and the sides evenly built up with rough stone-work. The top should be arched over, or shaded from the sun. A spout from the spring should carry the water into the house. If the spring is sufficiently high, it would be most convenient to have the water-trough in the house elevated upon a bench, as shown in fig. 1. There is then no necessity for stooping, to place the pans in the water, or to take them out. Where the spring is too low for this, the trough may

be secured by building of stone or brick, with walls 12 inches thick, double windows, and a ceiled roof. In such a house there will be no danger of freezing in the winter time. The drainage will be secured by choosing the site, so that there is ample fall for the waste water. The waste water should be discharged into a basin, from which a covered drain should be constructed. The character of the whole building is shown in fig. 3. The size will depend altogether upon the number of cows in the dairy. For a dairy of 20 cows there should be at least 100 square feet of water-surface in the troughs. The troughs should be made at least 18 inches in width, which would admit a pan that would hold 8 to 10 quarts at three inches in depth. A house, 24 feet long by 12 wide, would give 60 feet of trough, 18 inches wide, or 90 square feet. The furniture of the house should consist of a stone or cement bench, and an oak table in the center, upon which the cream-jars and butter-bowls may be kept. It is well to remember, that it is the universal experience of all dairymen, who have tested the matter, that cream or butter should never be placed upon the floor of a dairy. The impure air always descends to the

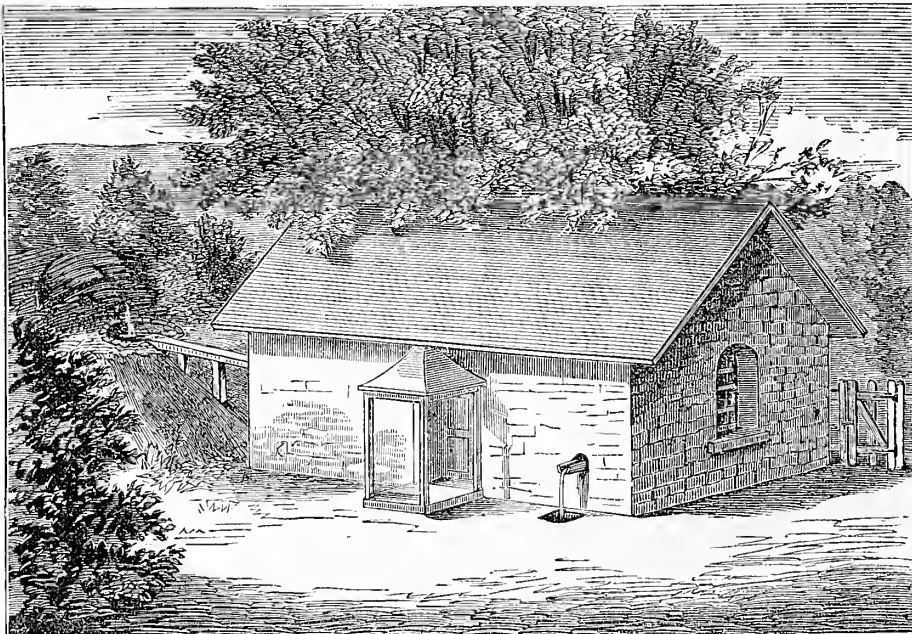

Fig. 3.—EXTERIOR OF SPRING-HOUSE.

be made on a level with the floor, as in fig. 2. The purity of the air is to be secured by removing all stagnant water or filth from around the spring, all decaying roots and muck that may have collected, should be removed, and the ground around the house be either paved roughly with stone or sodded. The openings which admit and discharge the water, should be large enough to allow a free current of air to pass in or out. These openings should

floor, and nothing is more easily injured in flavor by any impurity, than cream or butter. Two or three feet above the floor is the best place to keep either the cream or butter. For this reason we would rather have the water-trough in a spring-house raised at least 30 inches above the floor. In that case a grated opening should be made near the floor, for the purposes of ventilation. Where the deep-can system is used, a much smaller house will answer, with deep troughs.

The Pearly Everlasting.

There are many of our wild flowers which we admire as we see them in the woods and fields, but with which we do not think of associating the idea of cultivation. Yet many of our very common plants are prized abroad, and if one consults foreign garden books and catalogues, he will find both high praise and high

large corymb of flowers, or rather heads of flowers; for these heads, though not much larger than a pea, are made up of very minute florets, surrounded by many pearly-white scales, to which the beauty of the flower-heads is due. The engraving shows the summit of a stem, with the flower-heads of the natural size. In England this plant has been tried, among others, in bedding, on account of

some experiments in coloring it, after the European methods, and duly report the results.

The American Star-Thistle.

One of the showy plants of Arkansas, Texas, and other parts of the far West, is *Centaurea Americana*, the American Star-Thistle. It is



PEARLY EVERLASTING.—(*Antennaria margaritacea*.)



AMERICAN STAR-THISTLE.—(*Centaurea Americana*.)

prices given to things that he has known all his life after a fashion—but being wild flowers he has been on mere speaking terms, but has not, as it were, cultivated any friendship with them. Among the plants which are common, at least all through the Northern States, is the Pearly Everlasting—its botanical name is *Antennaria* for the genus—the derivation of this term is rather too obscure to describe here, but its full name is *A. margaritacea*, and nearly every one knows that this last means pearly.

The closely related "Life-Everlasting," or "Balsam," (the very strong and pleasant-smelling plant of which every good grandmother keeps a bunch in the garret to be handy "in case of sickness,") though it much resembles this, must not be confounded with it. That is botanically *Gnaphalium polycephalum*, and though a very good plant in its way, it is only an annual, and its less globular and more dingy heads, together with its strong odor, will at once distinguish it. Our pearly everlasting is a perennial, throwing up a number of stems a foot or two high from one root; these stems are very downy, indeed we may say woolly, and the numerous long, narrow leaves, are very woolly too, underneath, but green above; the stems branch very much at the top to form a

the light color of its stems and foliage, but there are many better plants for such uses than this. Our reason for calling attention to it is because its flowers have all the character of those known as "Everlasting flowers," and for persons who are fond of making up winter, or dried bouquets, wreaths, and the like, this is one of the very best things they can have. Indeed, wild though it is, it comes nearer the real "immortelle" of the French, than any of our cultivated flowers. We find that in the European catalogues of dried flowers, those of our native Pearly Everlasting are offered at a higher price than some of those we cultivate. It may be too late this year for those who wish to collect these flowers to find them—as we can not always time such things exactly right, but we are quite sure that lovers of everlasting flowers will be glad to have their attention called to this one. The flowers for drying should be collected before they have expanded too far; the flower-heads of some plants will show more of a yellowish center than those of others, and these should be avoided as far as possible. Of course only the most pearly should be chosen, and these, after tying in bunches, be dried away from dust and flies. To find out what our pearly everlasting is capable of, we shall try

an annual, growing two feet or more high, with a grooved stem; the upper leaves are entire, but the lower ones have broad teeth on the margins. The stem is branched above, each branch bearing a very large head of lilac-colored flowers, which is two or three inches across, and has much the appearance of an enormous thistle head. The outer flowers of the head are much larger than the others, and sterile, in which respect the genus differs from that to which our common thistles belong, as they have the flowers in the head all alike. The engraving gives a head of the natural size, and shows the greater size of the outer flowers. The bud or unopened head, given below the full one, shows a marked peculiarity of the plant; the scales to the involucre which surrounds the head, are most beautifully fringed upon the edges, with a row of straw-colored teeth or points. This showy plant has been in cultivation for the last half century, and though the seeds are kept by all the principal seedsmen, we see it in cultivation much more rarely now than we did a dozen or twenty years ago. It is a capital plant for producing a bold effect, especially if planted in a large clump, against a background of shrubs. It is usually sown like ordinary annuals in the open ground, but the

French gardeners think so much of the plant, that they sow the seeds early under glass, in order to get the flowers much sooner than they would if they sowed in the open border.

Using Concentrated Fertilizers in Gardening.

BY PETER HENDERSON.

Whatever kind of concentrated fertilizer may be used, I find it well repays the labor to prepare it in the following manner: to every bushel of fertilizer add three bushels of either leaf-mold (from the woods), well pulverized muck, sweepings from a paved street, or—in the absence of either of the above—common garden soil. In every case the material employed must be as dry as it is possible to procure it. When guano is used, be careful to have it thoroughly pulverized and broken up before mixing with the other ingredients. The fertilizer must be well mixed with the soil or mold used by turning it at least twice. This mixing should be done in winter, or early spring, and the material be packed away in barrels in a dry place for at least a month before using it. The main object of this operation is for the better separation and division of the fertilizer, so that when applied, it can be more regularly distributed over the land; besides this, no doubt the fertilizing qualities of the leaf-mold or other substance are developed by this treatment. Experiment has shown that this method of using concentrated fertilizers of nearly all kinds, materially increases their value. One of the most successful market gardeners in our neighborhood, has adopted this method for years, and in extensive experiments with different kinds of fertilizers, with and without being mixed, finds a saving of quite one-third in quantity in thus treating them. He finds that 1,200 lbs. of guano, mixed with two tons of garden soil, and sown over the surface after plowing, and then harrowed in, is equal to 2,000 lbs. of guano used without mixing.

We have ourselves experimented with guano, blood and bone, and bone flour, with nearly like results, and as a top dressing for grass, we think the advantage of mixing is even more marked. When fertilizers are applied to corn, potatoes, tomatoes, etc., in hills or drills, it is not only more economical to mix in this manner, but much safer in inexperienced hands; for when any strong fertilizer is used pure, injury is often done to the roots by their coming in contact with it in too great quantity in the raw state, owing to imperfect mixing in the hill or drill, while, if composted as advised above, the danger is much less. We are often asked as to the quantity to be applied to different garden crops. Taking guano as a basis, we would recommend for all vegetable crops, if earliness and good quality are desired, the use of not less than 1,200 lbs. per acre, mixed with two tons of either of the materials recommended. This quantity is used broadcast by sowing on the ground after plowing, and deeply and thoroughly harrowing in. When applied in hills or drills, from 100 to 300 lbs. should be used to the acre, according to the distance of these apart, mixing with soil, etc., as already directed.

In regard to which of the fertilizers is most desirable, we find but little difference, provided each is pure. Guano at \$80 per ton, is relatively as cheap as blood and bone fertilizer at \$65; bone flour at \$50, or superphosphate at \$40; for in the lower priced articles we find we are obliged to increase the quantity to obtain

the same results, so that the cost is nearly alike which ever be used. The all important point is the purity of the article, a matter that few working farmers or gardeners ever attempt to decide except by the results in culture, hence we advise each one who has been using a fertilizer that has proved satisfactory, to experiment lightly with another until the new article has proved its merits. The competition in the manufacture of articles so much in use as fertilizers, has in many instances forced down prices below the point at which they can be produced in a pure state, hence the wide spread adulteration with "salt cake," "plaster," and other articles utterly worthless but to make weight. Next in meanness to the quack that extracts money from a poor consumptive for his vile nostrums, is the man who compels the poor farmer or gardener, may be a thousand miles away struggling for an existence, to pay freight on the sand mixed with his guano, or the plaster in his bone dust. In this relation I am reminded of a retribution that fell on the "Sands of Life man," who figured so conspicuously a few years ago in New York. The advertisement of this philanthropic gentleman it will be remembered, was that "A retired clergyman whose Sands of Life had nearly run out," would for a consideration tell how the "running out" could be stopped in others. A kind hearted fellow in Illinois, deeply sympathizing with the old gentleman on account of his loss of "sand," sent him by express—but forgot to prepay—a thousand pounds of the article! It is reported that the "retired clergyman" on opening the box, expressed himself in a manner not only ungrateful, but utterly unclerical. We counsel no vengeance, but if some of these sand-mixing guano men could have the sand sifted out by their victims with compound interest added, and returned to them under the fostering care of an express company, it would be but even handed justice.

Notes from the Pines.

HERE IS TROUBLE! and I am the cause thereof. Moreover it is a lady who is in trouble, all through following my advice. Still I suppose this is what those who try to enlighten the world by appearing in print must expect. Every now and then I have received, through the courtesy of the editor, a letter of thanks, from some reader who has been helped by my "notes," but here is—well, if it were not from a lady, I should call it a "blowing up." It is, however, more in sorrow than in anger, and the case is not past remedy. The lady, who writes from Otsego Co., N. Y., says:

"I consider you the proper person upon whom to bestow my wrath, for did you not by your enticing representations, induce me to procure *Aquilegia carulea*, from the Rocky Mountains! the queen of the Columbines, verily the queen of all herbaceous plants! I received mine from—last fall, and early in the spring it was the first to show itself. Patiently and longingly I waited and watched its growth, as it developed its green bud, as it opened fully its green flower—as finally it changed its green for a dingy purple-pink. No spurs at all. People exclaimed, 'what a vile weed!' In mercy tell me is my plant the true *carulea*, or what is the matter? It is a dire disappointment to me."

If I were to recommend the little Brittany cow as a nice pet animal for a small family, and some one should order one and get a tall, lank, Texan instead, with horns so spreading that the barn-door must be widened, would it be right to blame me rather than the cattle dealer? The Rocky Mountain Columbine is all

right, my description of it was not over-drawn, and the only trouble seems to be with the dealer, who sent something else. Now if I am to be held responsible for the mistakes of seedsmen's and florist's clerks all over the country, I may as well give up horticulture, and not write another "note." The disappointment she expresses shows her to be a true lover of flowers, and if she will be patient for a while, I will try at the proper season to send her a plant of the true thing. . . . Some time ago I wrote that I was experimenting in

CARPETING BENEATH SHRUBS, with the double object of improving the appearance, and by occupying the soil, to avoid the necessity for weeding. There are several low greenhouse plants which will spread rapidly, and answer well for beds of greenhouse shrubs that are set out temporarily, but in the regular shrubbery we require something permanent. *Cerastium Biebersteinii* and *C. tomentosum* were not very successful, but they were planted where the shrubbery was the densest, and I have hopes of them if used where they can get more light. My most thorough success is with the moneywort, *Lysimachia nummularia*, the little trailer so much used for hanging baskets. Where this was set in sufficient quantities in the spring of last year, it now covers the soil with the densest possible mat of foliage; it covers so closely that not an inch of soil is to be seen, and no weed dares dispute possession. This answers the purpose so completely in one part of my shrubbery, that I shall extend it to others. There is as much difference between the appearance of a shrub-border with the earth so carpeted, and one with it bare, save for weeds, as there is between a carpeted and an uncarpeted room. I have also tried the so-called variegated moneywort, this is of a bright greenish yellow when grown under glass, but in the open ground it only shows its variegation in a dull sickly look, and the plant has nothing like the vigor of the ordinary kind. I am so much pleased with my experiments that I shall continue them with other plants, and report in due time. . . . There are some plants of no especial merit, that become very popular, and others which are really good, that fail of appreciation. In this latter class I regard

SEDUM SPECTABILE, which you figured when it came out, several years ago, as *S. Fabaria*, under which incorrect name it is still to be found in collections. It makes a dense clump of stems, some 16 or 18 inches high, each one of which produces a broad cluster of purplish-rosy flowers, and as their clusters are numerous and close together, they make a broad sheet of bloom over the whole top of the clump. One of its best qualities is the lateness of its flowering; it comes along in September, a time when flowers are none too numerous, especially those with delicate tints. I suppose the reason why this plant has not been better appreciated, is that its habit and foliage are much like those of the old *Orpine* or *Live-for-ever*, (*S. Telephium*) which has escaped from gardens, and has become a weed in many places. The showy sedum is propagated with the utmost ease by division of the clump, or by cuttings of the stems, and I know of nothing that is more pleasing in its season than a clump of this. . . . In our

FANCY BEDS, sometimes a plant will fail; I made a bed with *Colous Verschaffeltii*, *Achyranthes aureo-reticulata*, *A. Lindenii*, and *Gnaphalium lanatum variegatum*. For some reason the *Gnaphalium* did not grow well; it remained

stationary for weeks, until the other plants had quite outstripped it. As it was too late to get a bedding plant to replace the *Gnaphalium*, I remembered something I had seen in an European journal, so the *Gnaphalium* was pulled up, and its place filled by a row of tops cut from the *Sedum spectabile*; the flower clusters, still in very young bud, were cut with stems six or more inches long, and set out as if they were plants. They have gone on just as if they had not been separated from the parent plant, and are now in full bloom. . . . I wonder upon what principle the so-called

ORNAMENTAL GRASSES are selected. Seeing in the catalogue of a seedsman the names of several "ornamental" grasses, which I did not know, I procured a lot of seeds. The result is the greatest lot of trash I ever saw outside of a weed-heap. Some of the grasses, of which the seeds are offered for sale, are very pretty. The *Brizas*, *Stipa pennata*, *Brizopyrum siculum*, *Agrostis nebulosa*, and some others, are worth growing, but these "novelties" are enough to disgust any one with ornamental grasses. I could make a circuit of half a mile around the place, and load up a hay-rack with wild grasses more ornamental than any I have grown this year. . . . When I look out upon my bed of

PERENNIAL PHLOXES, I wish every reader could see them, and know how much brilliancy and beauty can be had at a very small expense. A few of the older kinds are common in gardens all over the country, where they are called French Lilac—probably for the sufficient reason that they are neither French nor lilacs. The garden varieties are from our native *Phlox paniculata* and *P. maculata*, which in their wild state vary so much, that the different forms have been described as distinct species. The European florists have by hybridizing, crossing, and selection, made wonderful improvements, and we now have them from the purest white to fine crimson, and often with two colors in the same flower, beautifully shaded, or in distinct markings; some are only 18 inches high, and others 4 feet or more. They are perfectly hardy, and require no care whatever—and with them the most magnificent display can be made. How the butterflies and the bees like them! In a warm day it is an interesting sight to watch the great number of butterflies that hover over them, as if by the brilliancy of their colors they had a right to claim companionship with the gay flowers of the phloxes. Fifty or more named varieties are offered by the florists—the newest always the dearest, and not always the best. . . . I have before mentioned my success with the true

HEATH, HEATHER, OR LING, *Erica (Calluna) vulgaris*.—(Now if any Scotchman is disposed to pick me up, and write a long letter, saying this plant is not the heath, I hope he will save himself the trouble, for I have been all through that discussion once.) Every European who comes to my place, is surprised and delighted to see large clumps of this plant; I have had it now these six years, and with its relative, *E. carnea*, it is hardy and satisfactory in all respects. The common form of the heath has behaved so well that I this spring sent to the celebrated Knap Hill Nursery, of Anthony Waterer, near Woking, Eng., for a set of all the varieties in cultivation. I received about a dozen, some remarkable for the beauty of their foliage, others for the size or color of their flowers, including a double one; these have stood the summer well, and have made a good growth. I shall protect them the first

winter, and if they fulfil their present promise, the bed will be a great satisfaction. . . . I last year learned a very useful wrinkle about

GLADIOLUSES which I have put into practice; however fine the flowers of a *Gladiolus* may be, the plant itself is not of elegant habit, and a bed of them is just a concentration of floral gawkiness. This year I set the *Gladiolus* bulbs among *Rhododendron* and other low growing shrubs. The spikes show brilliantly above the dark foliage of the *Rhododendron*, and the flag-like leaves are not noticeable.

Preserving Flowers—Winter Bouquets.

THIRD ARTICLE.

In the natural sequence of these articles, we should publish the methods of coloring the everlasting flowers, grasses, etc., but as the seeds we sowed with the view of obtaining flowers for this purpose, were put in late, we have not yet had sufficient material for experimenting. In all such matters we prefer to make a trial, before publishing the process, that we may see the difficulties which a novice will be likely to meet with. In the matter of coloring flowers and grasses, it is well to make one job of it, therefore the delay in publishing the method this month is of little consequence. The flowers and grasses should be collected as long as the season lasts, and dried in small bunches, as heretofore directed. Some of the most useful wild and cultivated grasses for bouquets will be found this month; they should be collected before they are so far advanced as to drop their seeds, or the parts of their flowers. Those collected while in blossom, will of course let fall their anthers, which is of no consequence. We have had some inquiries in regard to preserving ferns for decorative purposes, as well as to bleaching them. Some of the ferns are of exceedingly graceful outline, and are used in various ways; in making up flower-pictures, they are indispensable. They are sometimes grouped and placed between two panes of glass, to decorate the side-lights to a front or vestibule door. Some of the more delicate ones are used to place around the broad white margin of an engraving, and there are various ways in which they may be made useful. For all these purposes the ferns require to be simply dried between papers. As a general thing they contain but little moisture, and dry quickly; old newspapers will answer for drying, and there should be sufficient weight upon top, to keep them perfectly flat. When dry they must be kept under pressure, until wanted for use, otherwise they will curl out of shape. An old book, such as the bound volume of some newspaper, that is good for nothing else, may be used for pressing and preserving them in. Those who are fortunate enough to be able to procure the delicate and graceful Climbing Fern (*Lygodium*), will find it necessary to coil it carefully while pressing. As to bleaching ferns, they are to our notion more pleasing in their natural state; but they may be bleached, after they are dry, by the same solution used for bleaching grasses, which will be given later. Some fruits, or seed-vessels, are used in large winter-bouquets with good effect, and they are useful for decorating frames, small brackets, and other ornamental work; the seed-vessels of the sweet-gum tree, acorns with their cups, the pods of the bladder-tree, the keys of the ash, the winged fruit of the hop-tree, and numerous others that one will meet with in an autumn ramble, should be col-

lected, dried, and put away in a place free from dust and mice for future use.

Preparing Plants for Winter.

Those who have flowers in the open ground, which they wish to keep in the house during the winter, are very apt to delay taking them up until the first frosty nights show that they are in danger. For ourselves, we do not think it pays to take up geraniums and such soft-wooded things that are apt to grow out of shape during the summer, but we make cuttings and start with nice vigorous young plants, but those who have not made this provision, will take up the old plants. The first part of October is quite late enough to pot the plants that are intended for window culture. Any good garden soil will do for potting, and if it is likely to be too stiff and bake after watering, mix some sand with it; it is better to use liquid manure after the plant is well established, than to add manure to the soil. Use clean pots, and those without cracks, put crocks for drainage in the bottom, and then pot the plant, removing any straggling roots, and carefully press the soil firm around the plant. At the same time trim the plant into shape; do not be afraid to use the knife freely; the chances are that too much will be left rather than too much cut away. Shade for a few days, water as needed, and when the foliage shows that it has recovered from the shock of removal, more sun can be given. It is important to inure the plants to confinement gradually; set them on a veranda, or where they will be well exposed to the air and light, and yet be protected from frosts at night; if an unusually cold night occurs, take them in-doors. When finally taken in, place them in a room where the windows can be opened every pleasant day, and do not bring them where there is fire-heat, until the temperature makes it necessary. More house-plants are injured by too high a temperature, and too dry an atmosphere, than by cold. Preparations should be made for preserving half-hardy plants in a pit or in the cellar. If plants are to remain dormant until spring, several may be put into one box, with plenty of earth around the roots. See that the earth is not wet; plants when dormant are more likely to suffer from too much moisture, than from too little. They should be looked to now and then during the winter, and be watered if they absolutely need it. Geraniums cut back, winter well in the cellar, but if too much foliage and too many succulent stems are left on, they will decay. Those who have never tried it, will be surprised to find what a valuable adjunct a good dry cellar is to the garden in preserving tender plants.

THE EGYPTIAN BEET is among beets what the Trophy is among tomatoes. Last year the seed was scarce abroad, and some unprincipled dealers sent over a spurious article. This year we received seeds from both B. K. Bliss & Sons, and Peter Henderson & Co., of the real thing. These are so fine as early beets, and they are among the earliest, that we have kept up a succession of them. To have them in perfection they should grow rapidly, and be taken when about half grown. They then cook perfectly tender—in fact, are balls of crimson jelly—and whoever has not eaten them, dressed with a plenty of the sweetest butter, does not know of what a beet is capable. We always sow thickly, that there may be an abundance of the thinnings to cook as spinach.

A Fine Basket-Plant.—Tradescantia.

Hanging baskets, vases, window-boxes, and the like, are now among the most popular of household decorations, and the taste for these is likely to increase rather than to diminish. Almost any plant will grow in these, but those of a pendant or trailing habit are the most desirable, as in a basket, or other receptacle of this kind, the pleasing effect is much enhanced, if the plants hang gracefully over the sides. In most florists' catalogues we now find a distinct set of plants offered as "basket-plants"; these are generally of kinds which depend more upon the beauty of their foliage, than upon the abundance of their flowers. We have heretofore figured a number of these plants, and now give another, which is among the less common of these. We had the plant several years ago, but were glad to receive it again recently from Messrs. Long Brothers, of Buffalo, N. Y., who in their regular business as florists, make a specialty of hanging baskets. The plant in question is known in the catalogues of florists, both here and abroad, as *Tradescantia repens vittata*. It has much the habit of the well known *T. zebrina*, and *T. discolor*, also useful basket-plants, but as it has not yet flowered with us, we have not been able to satisfy ourselves as to the accuracy of the above name. The plant grows rapidly, and produces leaves that are strikingly marked with green and creamy white, in longitudinal stripes. The variegation presents the utmost diversity, and it is almost impossible to find two leaves marked precisely alike. The same plant will present leaves all green, some with a single line of white, and all white, with a single line of green, and between the two every imaginable diversity. Like the other Tradescantias, to which we have referred, this plant is especially adapted to house culture, as it will endure a dry atmosphere, and almost any amount of bad treatment, except freezing. Another peculiari-

ed in the soil, and it will grow as if nothing had happened. We have found that when grown in a cool atmosphere, the plant has a tendency to lose its variegation, but when this occurs, so readily is it propagated, that one

than an inch in diameter, are not certain to flower. The crown, or "pip," as florists sometimes call it, of the Lily of the Valley, when sufficiently developed to flower, should be of the size and shape shown in fig. 1. Those too



THE STRIPED TRADESCANTIA.

has only to start anew, by breaking off a branch with variegated leaves, and planting it. In filling a basket or vase, this Tradescantia will be found a very pleasing and useful plant.

Winter Forcing the Lily of the Valley.

BY PETER HENDERSON.

Within the past three years the demand for the flowers of Lily of the Valley has increased to such an extent, that though the importation of roots has probably trebled each year, the price of the flower is still quite as high as when the forcing first begun. The price last season, from December to May, averaged \$10 per 100 sprays at wholesale; a price which, when the bulk or weight of the flower is considered, is something wonderful, and probably higher in proportion to the bulk than that of any other flowers, unless it may be those of some species of Orchids. The high price of the flowers is due to the fact that the success of the crop is not always certain. The failures which attend it are mainly owing to the use of improperly developed roots. As with other similar plants, a certain size or development of the crown, or underground bud, is essential to produce the flower. What that size should be, is not, even with the most experienced, always easy to determine. In the Tuberose, the Japan and some other Lilies, we find that bulbs that are less

small to flower are like that shown in fig. 2. But these rules as to size and shape are not given as certain, for hardly any of us have had experience enough to say with accuracy at what size the crown of the Lily of the Valley, or the bulb of a Tuberose or Lily will not flower, although we may say with considerable certainty, if the crown is large, that it will do so. It is the want of this knowledge that, in my opinion, has made the forcing of the Lily of the Valley so uncertain; thousands of roots have been imported that have not given flowers sufficient to pay the first cost of the roots. The cost is about \$25 per 1000 for single crowns, and as each produces but one flower-cluster, it will be seen that nearly all should flower, to make the business of forcing fairly profitable, even at \$10 per 100. We last year imported what seemed a very fine lot, which, on coming into flower, showed that one-third were "blind," or flowerless. As in forcing the Hyacinth, and other similar bulbs, crowns of the Lily of the Valley should be covered up outside for a few weeks, before being brought into the greenhouse to force. Those we flowered last year were imported about the middle of November, and were then packed closely together in light, rich soil, in boxes three inches deep. These were covered up outside with hay until the first of January; they were then brought into a greenhouse, facing north, where there is no direct sunlight at that season. The temperature was kept at about 70°, with a moist atmosphere, and by the first of February they were in full flower. The Lily of the Valley could be grown finely in a Wardian case, as it would there get the proper light, with the necessary damp atmosphere. When grown in greenhouses, exposed to sunlight, it is necessary

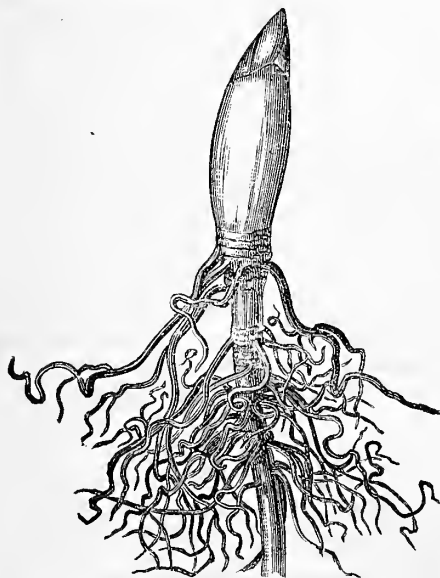

Fig. 1.—FLOWERING CROWN.

ty, which adapts it for basket culture, is the great ease with which it may be propagated; a piece of any size may be broken off and insert-

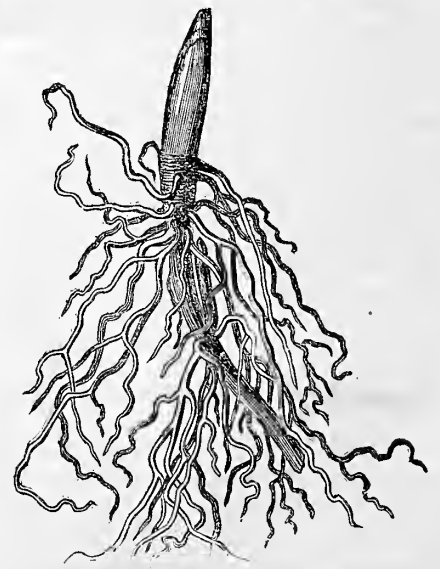

Fig. 2.—CROWN TOO SMALL TO FLOWER.

to shade the glass very heavily. When the flowers are about to open, they should then have light to give the leaves a healthy green color.

THE HOUSEHOLD.

(For other Household Items, see "Basket" pages).

How to Use Corn Husks.

Large quantities of corn husks are wasted every year, which might be made useful in many ways. When simply stripped into shreds and dried, they make soft wholesome beds and excellent cushions. We have seen the husks shredded upon an old-fashioned hatchel, but it would be much better to arrange a single row of teeth or blades, in a heavy board or block for a base, so that the husks could be drawn across them in small handfuls, and slit



Fig. 1.—TABLE MAT.

into shreds from a quarter to half an inch in width. The farmer who uneasily changes his seat every moment as he rides to market, upon the rough board placed across his wagon, would find ease and comfort upon a bag filled with corn husk strippings. Many other uses may be found for husks, but one of the most important, is the manufacture of mats, both for the table and for the door. Very elegant table mats have been made from the finer husks, and if care is taken to select the softest and best colored husks, the mats will not disgrace the most carefully furnished table. Fig. 1 represents a mat made of husks, which has done service upon our

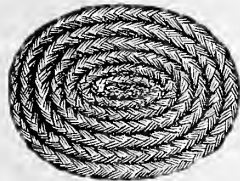

Fig. 2.—IN-DOOR MAT.

table for several years, and which is yet equal to new. It was made from the fine inner husks, which, when the corn is ripe, are of a delicate straw color. These are dampened with clean water, and plaited in a three cord plait made close, firm, and even. When one of the husks is nearly used up, the end of the other is placed beneath it, and the plaiting goes on; fresh ones are worked in, in this manner, as needed; the loose ends being always left projecting at the under side of the braid, to be cut off neatly afterwards. As the braid is plaited it is wound into a ball, until several yards are made. It is then trimmed of the loose ends, dampened again, and then sewed together by the edges with straw colored silk, into mats of any shape desired. If oval mats are to be made, the braid is to be folded side by side of such a length, as the length of the mat is to exceed its width. If the mat is to be round, or square, or six or eight sided, it is begun in the same shape, and

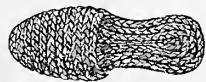

Fig. 3.—SLIPPER.

each round very carefully sewed to the one preceding it, in such a manner as to retain the shape. When it is finished it should be dampened once more and ironed with a hot flat-iron, and placed to dry beneath a folded sheet and a heavy weight. Very pretty mats are made by dyeing the husks of light neutral tints, such as drab, lilac, or French grey. The brighter colors of red, green, blue, or purple, are too glaring to look well upon a table,



Fig. 4.—BRAID.

and are not to be recommended. For heavier use the coarser husks may be selected, and very tasteful floor mats may be made of them. For these mats the brighter colors may be used with advantage, and a tasteful combination will have a good effect. Fig. 2 shows a mat of this character. At fig. 3 is seen another useful domestic article, a slipper, which is of far too infrequent use in farmer's houses. The braid is sewn together with double silk, or strong drab linen thread, and very serviceable, and even handsome slippers may be thus

made. Finally the kitchen door may be furnished with mats made of husks. For this rough use the thickest husks should be chosen, and they should be plaited together thickly, but tightly. The tighter and closer the braid, the more durable will be the mat. There are several kinds of kitchen mats that may be made. The plain braid may be sewn together with stout twine and a coarse needle, in the shape shown at fig. 2, or it may be made of any other desirable shape. Another method is to weave a double husk into the plait at each turn-over. These are put in as thickly as possible, as shown at fig. 4. When enough has been plaited, the braid is sewn together as before described, leaving the double husks which have been interwoven, projecting at the upper side, in the manner of a brush. These are clipped off evenly with a pair of shears, and the result is a mat like the one shown at fig. 5. This by no means exhausts the list or variety of mats. Ingenious boys and girls, may devise many other ways of using corn husks, and these will occur to them as soon as they commence to make one mat. For very rough use such as

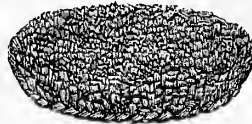

Fig. 5.—OUT-DOOR MAT.

out door purposes, and for barns, husk mats may be made by taking the head of a flour barrel or board, and nailing two cleats across to keep them together firmly; then boring holes close together with an inch auger, and inserting into each hole a bunch of husks tightly rolled together. A wooden peg is driven into the centre of each bunch, at the under side of the mat to secure it firmly, and when every hole is filled, the top of the mat is clipped evenly. When a mat of this kind becomes worn, it is easily renewed by replacing the old and broken husks with new ones.

Home Topics.

BY FAITH ROCHESTER.

DOES SICKNESS PAY?—Any sane person would, of course, say "no." Then a large proportion of our neighbors must be insane, if we may judge by their actions; for they do the very things that induce disease day after day, and year after year, groaning over various aches and pains, giving a week or a month now and then to the tedious necessities of sickness, and paying heavy doctor's bills every year. All this, as a matter of course—is mainly the result of ignorance. I mean ignorance in respect to the bodies we inhabit, and the laws of our Maker with regard to their growth and health. Many persons, who are learned enough in ancient languages and in general information about all sorts of things outside themselves, have no sort of knowledge as to living so as to be comfortable from day to day, getting the best use of their powers, and escaping disease and premature decay and death. Whole families of "cultivated" people live daily in such a way as to ruin their health, and so destroy the power of using and enjoying the culture they have acquired. Then they employ a doctor to cure them, but go on tearing down what they are paying him heavily for trying to build up. Does it pay?

My late neighbor, for instance: she is a woman of uncommon ability as a housekeeper. She scorns the idea of stopping to rest, and is proud of her ability to do more and harder work than any of her neighbors. She ridicules those who refuse to eat anything that tastes good, for the reason that it is injurious to their health. Nothing ever hurts her, according to her own story. But this woman has severe fits of sickness every year, and the list of her ailments is truly astonishing. Last year she paid over one hundred dollars to her doctors—money that she worked hard to earn when well enough to do so. Last month she still laughed at the idea of taking care of her health, but she was then under the doctor's care, and was sending away to procure expensive medicines.

It was a little five-year-old girl who set me upon

this train of thought to-day. She said of a former playmate:

"Huldah used to be always eating candy or sugar and bread. How much candy she used to eat!"

"And she is a poor sick child," I answered.

"Yes, she always had the tooth-ache, or the stomach-ache, or something."

We all remembered how much and how helplessly she used to cry sometimes, how pale she usually looked, how small she remained, while some of her playmates, more wisely fed and clothed and lodged, went on out-growing her. Little five-year-old declared she thought it didn't pay to eat candy, which only tasted good in the mouth for a few minutes, and then suffer so much to pay for it. Yet she is not such an unchildish child as to refuse the next stick of candy offered her. However, she will bring it to mamma, if she does as always heretofore, and accept it in half-inch lengths at her meals, dividing with others when it is dealt out to her. And, though you may laugh, I really believe that a child fed so moderately upon such concentrated sweets, gets more enjoyment out of them than one who eats twenty times as much in quantity.

It pays a good deal better to take a little rest, and to try a little fasting perhaps, when the body begins to complain of weariness and discomfort, (did you ever notice that the word disease is simply dis-ease, or *not-ease*?), than to stagger on with foolish bravado, and have to lie by in pain and weakness for weeks and months when these follies have piled up high enough to bring about the crash. It pays in dollars and cents to avoid doctor's bills by avoiding sickness. Our little family can not boast of robust constitutions, or of the most healthy habits in all respects—if we should wish to do such foolish boasting—but we do often rejoice that we are able to escape severe illnesses and that we have found no necessity for a doctor's care or doctor's bills for several years past, and that no medicines, beyond ease in the adjustment of our diet, exercise, rest, clothing, and cleanliness, ever seem needed or get used by us. Some sickness we must expect until sanitary conditions are allowed to each—until we are all wise enough to see the inter-dependence of each and all. Then we can work together and clear up this present "vale of tears," so that it may be a very pleasant and comfortable home for us while we wear our robes of flesh—and for such glorious consumption I hope I work no less cheerfully because "it may be," as you say, "millions and millions of years hence."

POTATO DIET.—Not long ago I remarked in the course of conversation with a lady that my children ate a good deal of bread and milk. "My Willie seldom eats it," she said. "He seems to need something more nourishing—eats a good deal of potato." Here our conversation was interrupted. If Willie eats milk, or eggs, or lean meat, with his potato, very well. But if he is kept upon potato and butter, or fat gravy, with white bread and butter, and cake and pastry at meals when potato is absent, he is very poorly nourished in my opinion. He may look fat, as children do when food is mainly of the fattening or heat-producing kind; but he will be likely to lack in bone and muscle. Potatoes alone cannot supply the system with enough of the mineral elements required for a healthy growth. So says Dr. Edward Smith, the author of an excellent book on "Foods." This book agrees in the main with one to which I have before referred, "The Philosophy of Eating," though less given to theorizing and more to the simple description of various kinds of food. In the Philosophy of Eating we are taught that potatoes are finely adapted to be eaten with lean meat—the starchy potatoes furnishing the fattening and heating elements which lean meat lacks, while the lean meat supplies the bone and muscle-making elements not afforded by potato or fine flour bread. Fat meat affords heating and fattening elements, like potato, but in a form less easily digested by most persons.

FAT CHILDREN AND CONDENSED MILK.—I have seen condensed milk recommended for infants deprived of their mother's milk, but the author of "Foods," says that it should never be used as a

substitute for new milk, whenever that can be obtained. He quotes another authority which states that such milk caused an undue development of fat, leads infants to refuse food of more simple flavor, and renders them less able to resist disease. Children like the condensed milk, on account of its sweetness. In the process of condensing the milk, good granulated sugar is added in the proportion of a pound and a quarter to each gallon of milk. The writer says "I have observed in a number of cases, carefully watched during the past eighteen months, that while condensed milk fattens, and while children apparently thrive upon it, the vitality of the child is below par to a very dangerous degree. Indeed so far as my experience goes, it has been invariably the case, that children fed on condensed milk, and are attacked with diarrhea at all severely, almost immediately got into a semi-collapsed state, and if brandy be not at once given, they die. I have observed the same with other diseases, as for instance measles, whooping cough, and bronchitis. The resisting power of the child has been bad, and those children brought up on the impure London fed cows' milk, will resist an attack of acute disease, better than children fed on condensed milk."

It is a very common error to suppose that fat is a sign of health, yet we all know that fat people are not in near so good condition for active usefulness, as are persons who have only a moderate amount of flesh. Children who have fat bodies and ruddy countenances, are sometimes badly diseased with decaying teeth, frequently have worms, and great tendency to croup and diphtheria.

HOW GOVERN THE BABY?—The questions of an old play-mate of mine, which came to me yesterday in a letter, is much like questions other mothers sometimes ask me. She says: "I do so wish I could see you with your little flock, and see how you manage with them, and with house-work, and sewing, and reading, and writing day after day, week in and week out. Wonder if you ever get nervous or worried, or in other words, lose patience, and feel like shaking the children. Or do you take to it kindly, and by natural or acquired grace, bear with all their whims, and teasing, and naughtiness, without feeling like slapping them. O! I wish I *did* know how you manage them! For instance, when they are about two years old, like G—, and you tell them not to go outside the gate, and they know all that you mean, but every chance they get run off, what do you do with them? Do you ever whip? It is my belief that a child can not be made to mind without feeling a hurt. But I have some friends, in whom I feel great confidence, who never inflict punishment for disobedience, and who think it a great shame to whip a child, and who insist that children shall be governed by love. But the truth is, the child of those parents, I have in mind, does not behave half so well as G—. Now I am sure I do not know what is the right way, and I wish I *did*. I would like to see my boy mind the first time he is spoken to, and I always wondered to hear people tell a child half a dozen times to do a certain thing, but baby hardly ever minds the first time we speak to him. I don't want to go around with a whip in my hand all of the time, and if you, with longer experience, have learned the way, I would like to be led."

I can not say that I have learned "the way" to make children of any age mind always, the first time they are spoken to. I have daily trials in that respect, and I suspect that it is because my children have so little fear of me. I do suppose that the frequent use of a whip or stick might make "better-behaved" children, than any who live at our house, but whenever I think over the matter, (and that is daily, or rather nightly,) I feel sure that a whip for family use would cost more than it would come to, and my prayer is still for more patience. I can see that the delay of the little ones is not real disobedience—that is, it is not intentional. They are "just going" to do what they are told, but their own business seems very important to them. I hate to speak sternly, or in a tone of command, but fretful entreaty is no better. A pleasant suggestion ought to suffice for children, who stand to

us in the relation of little friends. In all small matters of a personal nature, I think it pays well to say "please" and "thank you" to a child, and I have always habitually and rather unconsciously done this. "Please shut the door, dear," "Please hand me my thimble," and then "thank you" for the favor; for it does seem too bad, to call children from their play, to just wait upon us, and we must remember that our example is likely to be followed in their intercourse with each other.

Such a case, as my friend mentions, is different. I have had little trouble with runaways, but I think I should tie up the little truant feet every time they transgress prescribed bounds, until they learn to obey. Five minutes is "an age" for such a punishment to a small child. The object is to impress the mind, so that the little one will not forget to mind, or so that it will see that disobedience does not pay. It ought to be done good-naturedly, with tender pity expressed for the naughty little feet. Yesterday I tied up a pair of hands for striking brother. I hugged the little sinner, while I tied them up, and talked as though the owner of the hands of course wished to correct such a naughty habit, or to refrain from establishing such a habit; and she evidently rather took my side as against the hands. They were to stay tied together, until the clock struck, or about five minutes. When I untied them, I kissed each one, because I "was sure they would try to behave better now."

O dear! It takes line upon line, and precept upon precept, and I often feel discouraged—chiefly on account of my own mistakes, which almost all arise from a deficiency of patience. We are not good enough to carry out our own theories. Our little ones are chips of the old blocks, and inherit from us and from the sources whence we derived our tempers and temperaments, many of the evils which we deplore in them.

It may be best to "rule by love" alone, never appealing to a child's fears, but most of us feel that we have not time. We have to deal with our culprits too hastily. When two get into a quarrel, it seems impossible to do exact justice, because we have not time and are pressed with other cares. I can see clearly that it is best to take time, and that we ought to remember, that no other duties can exceed in importance, the moral culture of our children, but when it comes to the actual case, alas!

There is an excellent book, by Jacob Abbott, the author of the Rollo Books, called "Gentle Measures in the Treatment of the Young." I like this book better than the "Mother at Home," written by another Abbott. It is probably what most inquiring mothers are in search of, and it is more easy of comprehension, and what most persons would consider more practical than Mrs. Mann's, or Spencer's, or H. H.'s writings upon the same subject.

pudding—Sponge Cake—Catsup.

In July we gave some of the replies to the lady, who wished recipes for the above-named articles. We now add others:

PUDDING.—A Farmer's Wife, Masonville, N. Y., sends: Two eggs; one cup of sweet milk; one pint of flour; two tea-spoonfuls of cream-of-tartar; one do. of soda; two table-spoonfuls of butter; one of sugar. This is to be steamed from 20 to 25 minutes. My husband prefers sweetened cream on this kind of pudding, but maple-syrup is excellent.

For the benefit of those who have no steamer, I will tell how I make one: into a common dish-kettle place a small basin, turned upside down, put in water enough to about cover it, than set the dish that contains your pudding on that, and cover the kettle tight; if the water should happen to boil out, before the pudding is done, have some boiling water in the tea-kettle, which you may pour quickly and carefully down the side of the kettle, and all will be well.

PUDDING.—Aunt Esther, Windham Co., Ct., writes, that she sends directions for making one, that suits her George to a "T." To one quart of sifted flour add a measure each of acid and soda, of Horsford's bread preparation; mix it thorough-

ly with the flour, then wet it with cold, sweet milk, to which a tea-spoonful of salt has been added. Use milk enough to have the batter only just a little stiffer than that for wheat griddle-cakes; some flour requires more wetting than other. In the time of berries, add a cup of ripe berries, or cherries, or currants. In the winter a cupful of dried berries will do nicely, if they are moistened with a little water half an hour before using, and then rolled in flour, before putting into the pudding; dried currants are nice to put in at any time of year. Avoid much stirring, using only enough to mix the ingredients together, and cook immediately. You can put it into a covered pail, and place it in a kettle of boiling water, or in a basin in a steamer; cook it over boiling water; but I find so good market for it, that I cook mine in a four-quart pan, set over a kettle with boiling water. The water being boiling hot, when the pan is put over it, it must be kept so until the pudding is done. The time required to cook it depends on the quantity of flour used. For one quart of flour, one hour; for two quarts, two hours. The shape of the dish it is cooked in, makes some difference; it is better to cook a little too long, than not long enough. The pudding must be kept closely covered until time to take it off. For sauce, good thick sweet cream, and white sugar. This pudding is very easily and quickly made, and, if properly steamed or boiled, is very light and nice.

SPONGE CAKE.—Two cupfuls of sugar; four eggs; one-half cupful of water; two cupfuls of flour; one tea-spoonful cream-of-tartar; one-half do. of soda. Beat the sugar and yolks and half the water, until very light, then add the remainder of water, flour, and soda, etc.; when well beaten, add the whites of the eggs, and put immediately into the oven; bake one hour in not too hot an oven.

CATSUP that will keep one or five years, if it is not eaten before that time. Take of perfectly ripe tomatoes one-half bushel; wash them clean and break them to pieces, put over the fire and let them come to a boil, and then remove from the fire; when cool enough, rub them through a wire sieve; and to what goes through, add salt; two tea-cupfuls ground allspice and cloves, of each one tea-cupful; best vinegar one quart. Put over the fire again, and cook one hour, stirring with great care to avoid burning. Bottle and seal for use.

CATSUP, by "Mrs. D. B.," Long Island. Take a basket of tomatoes and pour boiling-hot water over them, so that the skins will come off easily, cut them up in a tin boiler, and cook them until they are soft enough to press through a coarse sieve, then put that which passes through the sieve, into the boiler again, and add four table-spoonfuls each of mustard, allspice, and cloves; two do. of black pepper, and one do. of red; two tea-cupfuls of salt; and three pints of vinegar. Cook over a slow fire until thick enough. I cannot state the time, as some tomatoes cook thick faster than others. I have just opened a bottle that is two years old in September, and just as good as when first made.

Cream Cakes.—Every one who has been in New England cities knows the Boston Cream Cakes. "Rel" sends the following recipes for making them:

CREAM CAKES.—One pint of water, one cup and a half of butter, four cups of sifted flour, eight eggs. Boil the water and butter. Stir in the flour slowly while boiling. Boil one minute, and when the dough is cool, add the eggs, which have previously been well beaten. Drop in shapely table-spoonfuls upon a buttered tin; bake in a quick oven.

CREAM FOR FILLING.—One cup of flour, two cups of sugar, one quart of milk, four eggs. Heat the milk, and when scalding hot, add the eggs, sugar, and flour, well beaten together, stirring as the mixture is slowly poured in. Flavor to suit yourself when the custard is cool. Make an opening in one side of each cake, and put in the cream with a spoon, taking care to put in enough. Be sure that the cakes are thoroughly baked, yet not scorched. This will make about fifty cakes. A quarter of the recipe given makes ten or a dozen cakes.

BOYS & GIRLS' COLUMNS.

The Doctor's Talks—The Garden and Seeds.

Some time last Spring I had something to say about your little gardens, I recollect that it was at the time of seed sowing, and I then expected to say more as the season ran along. Here it is now the time when most plants are ripening their seeds, and I find that I have said but little about the garden during the summer. Of course you have all had gardens of some kind, even if only a plant or two, or at any rate you have watched the plants in mother's garden, which is almost as well as having one yourself. Well, there have been the flowers,

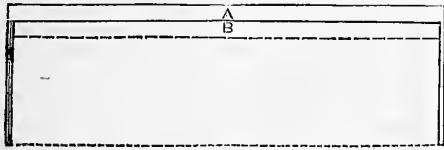

Fig. 1.—FOLDING THE BAG.

growing and blooming all summer. Everybody has said "how beautiful," and "how sweet."—Now what do you suppose the flowers have been at work about, and what have they made all this brightness and sweetness for? Perhaps you think that the flowers have all these months been huddling and blooming, spreading their beautifully colored petals, and sending out their charming odors, just to please you and others. No doubt that when you collected a little nosegay of the best and sweetest, and carried it to mother or sister, you thought that these plants grew only for your enjoyment and their's. If the plants could speak, they would tell a very different story; they would tell you that all along they have thought but little of you and your pleasure, indeed, that they thought but little about the present time, for they were too busy in caring for the future—for next year, and the years to come, and that so far as you have cut away the flowers, you have only been a trouble to them; that their whole time and care has been given to the ripening of those little dark colored seeds, which are to make plants another year, and if they did put on fine colors, and keep honey and sweet odors down in their little hearts, it was only to tell their friends the insects, that they had lots to do in the seed-making way, and that they wanted the help of the butterflies, the moths, the bees, and all sorts of winged insects. How the insects can help the flowers, is a long story, which can not be given here, but may be told another time, still the fact is well known, that many of the plants in the flower and vegetable garden, would not get along nearly so well in the seed business, without insect aid as they do with it. Yes, all this growth of stem and leaf, all this display of bud and flower, all the bright colors, and honey drops, and sweet odors have been to produce just such little dry dark-colored seeds as were planted last spring. Seed, plant, flower, then seed again, is the way with most plants, over and over, year after year. Do you recollect that last spring I asked you to



Fig. 2.—FOLDING THE ENDS.

think what a wonderful thing a seed is; what a mystery is wrapped up in the tiny grain, which will remain quiet for years, until the proper heat and moisture awaken the sleeping little plant within it? But now it is not the proper time to talk about growing the plant from the seed, we must consider the seed as the end of the season's work of the plant. If we left the seeds to take their own course, they would be scattered upon the ground near where the plant grew, or they would be carried to greater distances as they were taken by the winds, or thrown by the bursting of the seed pods. The ways provided for the scattering of the seed, are many and most interesting, but we do not wish to talk just now about seed scattering but of seed saving. If we allow seeds to go just as they please, those of plants from warm countries will be killed by the cold of winter; others will come up after laying on the ground until spring, but at the same time the seeds of weeds will come up too, and our flowering plants will be likely, while very young, to be crowded and killed by the more rough and strong young weeds. So in gardening we help nature, by gathering the seeds and keeping them until next spring, or the proper time, and then sow them where we can take care of the little plants, and give them the ground all to themselves, where they will not have to struggle and crowd against any others. If you look around among the plants, you will see that the seeds are in little cases or

Pods of very different forms. Some of these pods go open with a pop! and scatter the seeds all about; these you must gather just as they begin to ripen; others just break open, and need a little shaking or rubbing, to make the seeds come out, and there will be still other kinds of seed-vessels. So you must exercise a little care in the matter. The best way is to have some paper-boxes, and put the seed-pods in these for a few days, until they dry; then rub the seeds out, pick out the remains of the pods, stems, and other coarse things, and then put the seeds on a paper, and carefully blow away the light dust that is among them. Mind, that when you gather the seeds, you put their name with them; write this on a piece of card, or on a bit of stick, to keep with the seeds while they are drying. Never have seeds of any kind anywhere, unless there is a name with them; this will avoid much trouble and guessing. Having the seeds all dried and cleaned, they are to be put away for winter; some make little paper-bags, by pasting them just like the grocer's bags, only much smaller, and these are very good. But I want to tell you how to make a bag without any paste, which can be larger or smaller, as you have few or many seeds, and which can be made anywhere in a "giffy;" if you are in a garden and wish to give a friend a few seeds, or if you are in the fields or woods, and find a plant the seeds of which you would like to save, if you have only a bit of paper, you can make a bag as good as the best.

How to make it.—You need a piece of paper, letter paper or smooth brown paper are as good as any, somewhat longer than wide; this you fold over, but not quite equally. See figure 1, the edge of the part of the paper you fold over, should come to the line between A and B in the figure. Then fold A over on to B, and both together over to the dotted line below B. This is twice as easy as it seems in explaining it. Then turn the paper over, and fold one end as shown at the right hand of

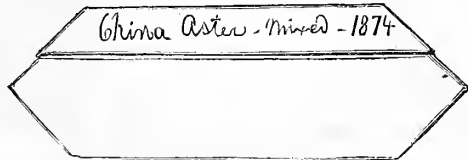

Fig. 3.—THE BAG COMPLETE.

fig. 2. Next fold the point b over in the same manner, and tuck the point b under the fold a, and it will appear as seen on the left-hand end of the diagram. You can prepare your bags by folding one end beforehand; when ready to put in the seeds, you can open the bag by blowing at the unfolded end, and when the seeds are in, that end is closed, by folding it just as you did the first end. This makes a bag, from which the finest seeds will not escape, and which for all but very large parcels, such as vegetable seeds, is as handy as need be. There is no paste required, no string to tie, and a very neat parcel can be made with common paper. But before you put the parcel away, do not forget to label it. Figure 3 shows how this is done. Like all such things, these bags are much easier to make, than to describe, but if you take a piece of paper, and follow the directions, I think you will succeed the first time. Seeds should not be put away until dry, and then they should be kept in a cool, dry place, where mice will not find them. I can not end this seed story, without asking you to put away many more seeds than you will be likely to want for yourself. Always have enough to give away, for you do not know how much pleasure may be inclosed in the little packet with the seeds. To care for and give away flower seeds, is one of the ways in which even boys and girls can help to make the world better.

THE DOCTOR.

Aunt Sue's Puzzle-Box.

DOUBLE ACROSTIC.

The initials and finals give the names of two rivers.

- 1. An island in Africa.
2. An exclamation.
3. A heverage.
4. A bird.
5. A girl's name.
6. To deplore.
7. A precious stone.
8. A river in Kansas.
9. A girl's name.
10. An exclamation.

HERBER J. K.

NUMERICAL ENIGMA.

I am composed of 13 letters:
My 3, 11, 13, is a city in France.
My 4, 10, is to perform.
My 12, 2, is to perform.
My 8, 1, 5, 9, 11, is a coat.
My 13, 7, 8, 11, is a city in France.
My whole is to be found between two continents.

GEO. H. FULLER.

METAGRAM.

In the name of a certain animal may be found: 1. Two large bodies of water; 2. Two very important pronouns; 2. Part of the face; 4. A measure; 5. A Hebrew measure; 6. A disgusting insect; 7. A country; 8. Invalid; 9. An eminence; 10. A musical note; 11. An unpleasant sensation; 12. Ice; and 13. A preposition. M. P.

PL.

Het hapt hatt daies of ourten oto entof sapes hoghurt eth wornar fedlies fo mansense, chivh a nam fo deeltax tisrip actonn ostop of trade.

CROSS-WORD.

My first is in Fannie hut not in Will,
My next is in quart, but not in gill,
My third is in short but not in long,
My fourth is in smile hut not in song,
My fifth is in rind but not in peel,
My sixth is in iron hut not in steel,
My seventh is in grandeur hut not in station,
My whole is a virtuous occupation.

ARTHUR AND RANNIE.

CONCEALED CAPES.

- 1. I can never be sufficiently grateful to that man.
2. It was a horribly dismal morning.
3. The sign was over a cellar door.
4. Is the Roc a fabulous bird?
5. Do it better? O! Ma, I never can.
6. Here, Ma, you do it for me.
7. Otto rang over so many times before the door was opened.

T. SCHWARMAN.

TRANSPOSITIONS.

- 1. One who in danger's always found
Becomes a tiller of the ground.
2. A female name, by sudden change,
Brings forth a fruit to us quite strange.
3. One who is made by debt a slave,
Becomes a dish I do not crave.
4. Transform one skilled in sacred lore,
Into a dweller by the shore.
5. A place where fire is used to burn,
Becomes a torch by skillful turn.

ENRICO.

CHARADE.

Two plants—the first one very bitter,
The other often known as "sweet,"
Will form a coin whose golden glitter
The eyes of Eastern travellers meet. HENRY.

DIAMOND PUZZLE.

The center letters, perpendicular and horizontal, form a well-known city.

- 1. Part of a cage.
2. A pronoun.
3. Malice.
4. A city.
5. Income.
6. The latter part of life.
7. Part of a book.

C. E. A.

WORD SQUARE.

- 1. A flag by several countries used,
'Tis not with flag of truce confused.
2. A kind of juice, unpleasant taste,
That's rather thick—a kind of paste.
3. By Indians used as food; by them
Long raised, from grain to glossy stem.
4. A game that men of pleasure play,
When into gilded dens they stray.

HENRIQUES.

ANSWERS TO PUZZLES IN THE AUGUST NUMBER.

ALPHABETICAL ARITHMETIC.—(Key: Buy it for me.)
213)657843(3088.

SQUARE WORDS.—1. M A N S E 2. L E A S T
A R E N A E L D E R
N E V E R A D I E U
S N E L L S E E M S
E A R L Y T R U S T

TRANSPOSITIONS.—1. Angel, angle, glean. 2. Peri, pier, ripe. 3. Meteor, remote. 4. Edom, dome, mode. 5. Stare, rates, rates, tears.

CHANGED HEADS.—Home, dome, Rome.

CROSS WORD.—Florida.

ANAGRAMS.—1. Moribund. 2. Laughter. 3. Decimals. 4. Dyspepsia. 5. Blithesome. 6. Landscapes. 7. Ornamental. 8. Brilliance. 9. Prospectus. 10. Meddlesome.

DOUBLE ACROSTIC.—Carlisle, Portland.

C- ar -P
A- mo -O
R- ca -R
L- as -T
I- mperia -L
S- ab -A
L- oo -N
E- dwar -D



CRUELTY TO ANIMALS.—WHO DID IT?—*Drawn and Engraved for the American Agriculturist*

POSITIVES AND COMPARATIVES.—1. Mist, mister. 2. Salt, psalter. 3. Sauce, saucer. 4. Doll, dollar. 5. Shoe, sure. 6. Mast, master.

Send communications for the *Puzzle Box to Aunt Sue*, Box 111, P. O., Brooklyn, N. Y., and not to 245 Broadway.

Aunt Sue's Chats.

BESSIE BENNETT wants to know "when capital p's and m's, should be used in writing 'mamma' and 'papa.'"—Capital letters when you use their names as proper nouns;—small letters when you write them as common nouns. Thus: "I am going out with Father," or "I am going out with my father."—She also says "won't you please explain how the Alphabetical Arithmetic puzzles are done?"—Won't some of you clever arithmeticians tell me how to "explain" it to her? Bessie has a few words to say on the fish question too.—"Perhaps the reason your niece Lottie's fish died, was because of the salt in the bread she gave them, for some say that salt kills them, (are you not thinking of birds, Bessie?) We used to have an aquarium; it was tolerably large, and we got some pretty small stones to cover the bottom, and several large ones with holes in them for a pyramid in the centre. The fish seemed to play 'hide and seek' among the stones. The aquarium was stocked with gold fish from Cincinnati, (Bessie writes from Clark Co., Ohio) and quite a number of common fresh water fish of different kinds from a creek. We had one fish, a pike, whose head looked like an alligator's; he ate smaller fish up, or at least they disappeared and we suspected him of eating them. We fed them with worms, macaroni, and occasionally little pellets of flour and water," and here Bessie's history ends. What became of the aquarium or of the voracious pike, she doesn't say. I wonder if I couldn't finish the story thus: "the pike died after all the rest of the fish disappeared; we had ceased to take

any interest in the aquarium; it stood around empty for some time, and now I believe it is in the barn somewhere, with one of its sides broken." How nearly am I right, Bessie?

A. D. (Annie Dominy?) wants to know if I ever saw the characteristics for a woman alphabetically arranged, and if I will please write them out for her. Yes, dear, here they are: Amiable, Benevolent, Charitable, Domestic, Economical, Forgiving, Generous, Honest, Industrious, Judicious, Kind, Loving, Modest, Neat, Orderly, Pleasant, Quiet, Reliable, Sincere, Tender, Useful, Virtuous, Wise, Exemplary, Yielding, Zealous. I quote from memory, and may not have them in the original form, but perhaps they are near enough for your use.

Thanks for puzzles, letters, etc., to Alf., Robt. W. Moor, Italian Boy, Capt. John W. W., and X. Answers should always accompany the puzzles sent.

Cruelty to Animals.

There are cases in which we must kill animals to keep them from hurting us, or because we need to use their flesh or skins. Also it is right that we deprive other animals of their liberty, and make them work for us. All these things can be done without cruelty; if we must kill, it can be done quickly and without much pain, and if we make them work for us, we can treat them so kindly, that they will love us and look upon us as their friends. No right thinking, really good person, will ever needlessly pain an animal. There are many, we are sorry to say, who will needlessly beat, brutally kick, and otherwise hurt a helpless animal. Think of a man kicking a gentle, useful cow! Let us hope that such people are not as cruel as they seem, and that they do not know or think how wrong it is. Young people are sometimes cruel as well as old ones. We do not like to think of a boy or girl as cruel, and had much rather hope that in

their desire for sport, they forget that they are giving pain to a poor helpless creature. What made us think of this was the picture given above. It is a very good picture so far as the art goes, but in the story it tells, it is a sad one. Some youngsters have been ill-treating a kitten; some tin vessel was tied to the poor creature's tail, and the frightened thing stoned and worried to death. The old lady came too late, the poor kitten is past saving; one guilty fellow has run away, and the other, all the while he is hiding a stone behind him, tries to make grandmother believe that it was not himself, but that other boy. No wonder he is ashamed, and now that the excitement of the hunt is over, he does not like to own that he has had a hand in such meanness, and coward-like, wishes to put all the blame upon some one else. You know that cruelty is not confined to young persons, but there is so much of it among men, old enough to know better, that there are now in most cities and towns, societies for preventing cruelty to animals, and laws have been passed which make unnecessary cruelty punishable by fine and imprisonment. If a man drives a horse which is too lame to travel, or if he beats his horse cruelly, he can be sent to jail where he can think over the matter. These societies do not often exist in the country, but there is need of them there. Let us have some. Let the boys and girls in each neighborhood, or each family, be a society to prevent cruelty to animals. If the other boys and girls do not agree in this, then be yourself a society of one. It is not the constitution, the by-laws, and the officers of a society, which make it useful, but it is the spirit with which its members work, and if one of you youngsters—a society of one—by quietly taking the part of those who can not speak, can prevent a horse from being beaten, or a kitten from the fate of the unfortunate in the picture, you will do quite as much good in your own little circle as if you had all the machinery of a society to help you. Here is prosperity to the noble societies of one!

Life Insurance.

Among the many useful applications of life insurance, not the least is that by which it may be made to enhance the financial credit and business prospects of individuals and associations. A young merchant or manufacturer of good standing, reliable character, industrious and energetic, makes application to a moneyed institution for a loan, wherewith to enlarge his business, or to a wholesale dealer for increased credit line for the same purpose. In either case, with the aid of good backing, sufficient endorsements on his paper, he will no doubt be cheerfully accommodated. Or it is possible that, on his own honest face and good reputation, both banker and merchant would gladly aid him. Both would feel perfectly well satisfied that nothing but death could possibly intervene, to prevent him from fulfilling to the utmost any contract in which he might engage. They know that his business is prudently managed; that he is energetic and industrious; that his record in the past is sufficient guarantee for the performance of all promises he may make for the future. But has either the banker or the merchant, in giving this credit, discounted the possibility of the death of the debtor? This is something that ought to be, if it is not, taken into consideration. In the happening of such an event, who will repay the money loaned; or take up the paper given for the wares purchased on time? Should death happen at a critical period, on the eve of the performance of an important business operation, who, then, could carry on the negotiations to a successful issue? In less familiar and less competent hands than those of the deceased, it would be impossible to carry on the business with any great prospects of success. In fact, experience has taught us that almost all experiments of this kind prove failures. Creditors would promptly bring in their bills; the executors, finding these claims pressing on them, would order a sacrificial sale of the assets, and the property would be sacrificed in order to realize ready money. Outstanding accounts in favor of deceased persons are notoriously slow of collection, and this would naturally do much to increasing the embarrassment. In this way many a prosperous undertaking is brought to grief; the capital invested is sunk beyond recovery, and the creditors, disappointed at receiving only a moderate percentage of their claims, indulge in a few anathemas and resolve to do no more business "on space" hereafter, unless on the basis of good security.

A policy of life insurance in a good company, furnishes complete protection against this loss, disaster, and ruin. Such a Company is the United States Life Insurance Co., of this city.

Devoe's Brilliant Oil.

Insure your life and your property against accident, by using Devoe's Brilliant Oil. No accident is possible in its use. Recommended by The Fire Insurance Co's., and Fire Commissioners.

Common kerosene is not safe. Devoe's Brilliant Oil has an established reputation as an oil safe beyond all chance. IS THE FINEST ILLUMINATOR IN THE WORLD. Ask your dealer for it.



For sale by Watchmakers. By mail, 50 cents. J. S. BIRCH, 37 Maiden Lane, New York.

IT IS NOT ECONOMY

To buy a poor Shee. Try Good

Cable Screw Wire FOR ECONOMY.

FOR FALL AND WINTER Agricultural Implements and Machines

P. O. Box 376. R. H. ALLEN & CO., 189 & 191 Water St. New York City.

MONEY MADE RAPIDLY with Stencil and Key Check Ourfits. Catalogues and full particulars free. S. M. Spencer, 117 Hanover st., Boston, Mass.

READ THIS TWICE.

Waltham Watches.

These celebrated Watches have been greatly improved during the present year, and several new sizes added to the list. The stem-winding and setting attachment can now be had with any grade or size, and all the old established grades of key-winders are also made as before. Any one who contemplates buying a watch, either now or in the future, should send for our new Descriptive Price List, which is now ready **AND SENT FREE.** This describes all the Watches, large and small, Ladies' and Gentlemen's, Gold and Silver, with prices of each, and contains besides information in relation to watches useful to every one. It also explains in full our plan of sending single Waltham Watches at low prices to any place in the Union by mail or express, with the bill to collect on delivery—with privilege to the purchaser to open the package and examine the watch before paying, and with no obligation to take it unless entirely satisfactory. Thousands have obtained genuine Waltham Watches from us in this way, and all have received full value for their money. A large assortment of extra heavy cases for the Pacific trade always on hand. Every one should send for a Price List, as the farther you live from New York the more advantage it is to deal with us. When you write please mention that advertisement was seen in the *American Agriculturist*. Address **HOWARD & CO., No. 222 Fifth Avenue, New York.**



Rifles, Shot Guns, Revolvers, Pistols, Ammunition, Fishing Tackle, etc. For Price-list, see page 157, April No. *Am. Agriculturist*, or address, with stamp, **GREAT WESTERN GUN WORKS, 285 Liberty St., Pittsburgh, Pa.**

(CIRCULAR.)

Consumers' Importing Tea Co., No. 8 Church Street, P. O. Box 5,509. New York City.

This is a combination of capitalists to supply the consumers of Teas throughout the United States on the mutual principle.

We have experienced agents in all the best districts of China and Japan to select Teas especially for our trade.

We expect every consumer of Teas to render us all the assistance they can in carrying out our enterprise, as we make a specialty of **SUPPLYING CONSUMERS ONLY** (and allow no middlemen to make any profit on our importations), which will enable us to supply them with Teas at prices lower than have ever been known, and of those fine qualities that seldom reach the interior, being sold only in the large cities and among the very wealthy.

Hoping the consumer will take an interest in our enterprise, and send at once for a circular with full explanations of how to proceed to obtain our goods, we remain,

Most respectfully yours,

Consumers' Importing Tea Co., No. 8 Church Street, P. O. Box 5,509. New York City.

Entered, according to Act of Congress, in January, 1874, by the Consumers' Importing Tea Co., in the Office of the Librarian of Congress, Washington, D. C.

W. A. COVERT & CO., Produce Commission Merchants, No. 68 Pearl Street, New York. "Quick sales and prompt returns." Send for our weekly Prices-current and Marking Plate.



EXTRACTS FROM AMERICAN INSTITUTE REPORTS.

The **ASBESTOS ROOFING** is adapted for steep or flat roofs in all climates, and can be cheaply transported and easily applied. Is furnished in rolls containing 200 square feet each, packed in strong skeleton cases. **ASBESTOS ROOF COATING** for restoring and preserving roofs. In 5, 10, and 20 gallon kegs and barrels. **ASBESTOS PAINTS** in colors, for Shingle and Tin roofs, and all outside work. In 1, 2, and 3 gal. cans, kegs, and bbls. **ASBESTOS CEMENT**, for repairing leaks of all kinds on Roofs. In 10 lb. palls, 5 and 50 lb. kegs. **ASBESTOS BOILER FELTING, ASBESTOS BOARD and PAPER, SHEATHING FELTS, ASBESTOS, &c.** These materials are prepared ready for use, and are put up for shipment to all parts of the world. Send for descriptive Pamphlets, Price Lists, &c., &c. **EXCLUSIVE SALE AND LIBERAL INDUCEMENTS TO GENERAL MERCHANTS AND DEALERS. Patentee and Sole Manufacturer, H. W. JOHNS, 87 Maiden Lane, N. Y. ESTABLISHED 1853.**

VICK'S CATALOGUE of Hyacinths, Tulips, Lilies, and all



Now published for Autumn of 1874, and will be sent free to all who apply. 32 pages—50 illustrations. Address, **JAMES VICK, Rochester, N. Y.**

GEO. A. PRINCE & CO. ORGANS & MELODEONS.

The Oldest, Largest and Most Perfect Manufactory in the United States.

54,000

[Now in use.]

No other Musical Instrument ever obtained the same popularity.

Send for Price-Lists. Address **BUFFALO, N. Y.**

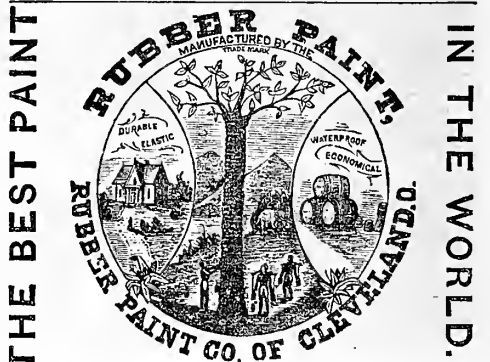

Branch Office and Factory: 506 West Street, NEW YORK. **Any Shade from Pure White to Jet Black.** A combination of the purest paint with India Rubber, forming a **SMOOTH, GLOSSY, FIRM, DURABLE, ELASTIC, and BEAUTIFUL** Paint, unaffected by change of temperature; is perfectly water-proof, and adapted to all classes of work, and is in every way a better paint for either inside or outside painting than any other paint in the world. Being from one-fourth to one-third cheaper, and lasting at least three times as long as the best lead and oil paints. **Be sure that our TRADE-MARK** (a fac-simile of which is given above) **is on every Package.**

Prepared ready for use, and sold by the gallon only. There has never been a paint offered the public that has become so popular (in the same time) and given as perfect satisfaction as the Rubber Paint. Send for sample card and testimonials.

A SILVER TIP Adds Five Cents TO THE COST OF A SHOE, and \$1 to its value.

DUTCH BULBS & SMALL FRUITS.

Our New Autumn Catalogue of BULBS AND SMALL FRUITS,

Beautifully illustrated with many engravings, and a splendidly-colored two-paged Lithograph of

A GROUP OF HYACINTHS,

Is now ready, and will be mailed to all applicants enclosing ten cents. Regular customers supplied gratis. Our list of

SMALL FRUITS

Comprises every desirable variety of

Strawberries, Raspberries, Grapes, etc.

Bulbs and Plants mailed to any address at Catalogue prices. Address

B. K. BLISS & SONS,
SEED, PLANT, & BULB WAREHOUSE,

34 Barclay St., New York
P. O. Box No. 5712.



BULBS! BULBS! BULBS!

50 HARDY FLOWERING BULBS. (Our No. 4 collection,) mailed to applicants enclosing \$3.00. Illustrated catalogue of Bulbs free.
W. H. SPOONER, Boston, Mass.



HYACINTHS, TULIPS, CROCUS, LILIES,

and all other Bulbs for planting in the Autumn; also Bulb-Glases, Fancy Flower-Pots, Fern-Cases, Winter-Flowering Plants.

The largest and finest assortment in the country. *Prices moderate.* Descriptive Catalogue mailed to all applicants *free.*

HENRY A. DREER,
714 Chestnut St.
Philadelphia, Pa.

BEFORE BUYING BULBS

send stamp for the latest and best catalogue.

WASHBURN & CO.,
100 Tremont Street,
Boston, Mass.

DUTCH BULBOUS ROOTS.

J. M. THORBURN & CO.,

15 John St., New York, announce the largest and most varied Importation of Dutch Bulbs ever received in this market. Catalogues on application.

DUTCH BULBS.—Our Annual Importation of selected Hyacinths, Tulips, etc., etc., just received in prime order; for Catalogues address **D. T. CURTIS & CO.,** Seedsman and Florist, 161 Tremont-st., Boston, Mass.

Our New Descriptive Catalogue of Green and Hot-House Plants, ROSES, FLOWER SEEDS, AND SMALL FRUITS,

Including all the novelties for 1875, will be ready for distribution in October, and will be sent to any address on receipt of 25 cts., which amount will be refunded in Flower Seeds from our list with first order for plants amounting to \$1.00 or more. Our Retail and Wholesale Price-Lists are both ready for free distribution.

MASSEY & HUDSON,
Chestertown, Kent Co., Md.

Stephen Hoyt & Sons, NEW CANAAN, CONN.,

Offer for sale a very large and superior stock of **FRUIT AND ORNAMENTAL TREES,** consisting largely of **Apple and Peach Trees.** Also, **Cherry, Pear, and Plum Trees.**

A splendid lot of **Concord,** and other Vines, one and two years old.

75,000 La Versailles, Cherry, and White Grape Currants. **200,000 Apple Seedlings,** two years old, etc., etc.

GRAPE-VINES.

LARGEST STOCK IN AMERICA. Extra quality. Reduced Prices. **T. S. HUBBARD,** Fredonia, N. Y.

FRENCH PEAR SEED—FRENCH NURSERY STOCK—

of all sorts furnished in large quantities. Also **ROSES.** Send for Price List. Order early.
E. T. DICKINSON, Chateau (par Antony) Seine, France.

THE EARLIEST PEACH—ALEXANDER EARLY—

Three weeks earlier than Hale's. Large, Very handsome. **FIRM.** Excellent. A fortune for Peach-growers. In dormant bud, by mail, two for \$1. Less per hundred, by express. Send for circular. Address,
G. H. MILLER, Norwich, Muskingum Co., Ohio.

Amsden's June Peach—The earliest Peach known. Endorsed by the **Jasper Co. (Mo.) Horticultural Society.** Send for circular. Buds by mail, 50 cts. per dozen. **L. C. AMSDEN,** Carthage, Jasper Co., Mo.

New Strawberries and Raspberries, Currants, Vines, Fruit Trees, &c. See p. 310 in Aug. No. Berry Baskets & Crates. **R. H. Haines,** Malden-on-the-Hudson, N. Y.

50,000 Wilson's Early Black-berry, and plants of all the best small fruits for sale. **SILAS WALTON,** Moorestown, N. J.

GARDEN & FLOWER SEEDS, every description. Bulbs, New and Rare Plants, and all Garden Requisites. Catalogues free, **HOVEY & CO.,** 53 N. Market St., Boston, Mass.

Trees, Vines, Shrubs, Plants, Etc.

- 500,000 Apple, Pear, etc.
- 100,000 Peach Trees.
- 100,000 Grape Vines.
- 50,000 Currant Bushes.
- 500,000 Sweet Chestnut Trees.
- 10,000 Spanish " A CHESTNUT CIRCULAR FREE.
- 1,000,000 Evergreens, best in market.
- 200,000 Deciduous Trees and Shrubs.
- 50,000 Magnolia Acuminati, one year, fine.
- 10,000 Tulip Trees, 6 to 12 feet.
- 2,000 Weeping Mountain Ash.
- 50,000 Rose Bushes.
- A new Descriptive Catalogue and Wholesale List free.
- 21st Year. 40 Acres. 11 Greenhouses.
- Address, **STORRS, HARRISON & CO.,** Painesville, Lake Co., Ohio.

New Early Peaches, Dutch Bulbs, New and Rare Plants.

Rivers' New Early Peaches, Early Beatrice, Early Louise, and Early Rivers'. The earliest Peaches known, with a collection of other new varieties of Peach raised by Mr. T. Rivers—a fine Stock.

Beurre d'Assumption, Souvenirs du Congress, and other new Peaches.

Dutch Bulbs—Hyacinths, Tulips, Lilies, Narcissus, &c. New and Rare Plants—Plants for Winter-flowering, &c. Catalogues mailed on application.

JOHN SAUL, Washington City, D. C.

PEACH TREES!

A LARGE STOCK of old and new varieties; also of **CHERRY, APPLE, APRICOT, NECTARINES, and SEEDLINGS** for Nursery Planting. Wholesale List free.

HOOPES, BRO. & THOMAS, Cherry Hill Nurseries, West Chester, Pa.

PEAR-TREES FOR THE MILLION.

Largest stock in the West; fine assortment; extra quality; packed to go safely any distance. Satisfaction guaranteed. Prices low by hundred or thousand. A full assortment of other trees, shrubs, plants, etc. Illustrated Catalogue mailed free to applicants.
R. G. HANFORD, Columbus Nursery, Columbus, Ohio.

ROSE BUDS IN WINTER.

Now is the time to get Roses for Winter Bloom. We send strong Pot Roses safely by mail pos-paid. Purchasers' choice of splendid ever-blooming varieties.
5 for \$1.00, 12 for \$2.00.

See our elegant descriptive catalogue containing full directions for culture, &c. Sent free to all who apply, address **THE DINGEE & CONARD CO.,** Rose Growers, West Grove, Chester Co., Pa.

- APPLE,** first-class, 5 to 7 ft.; 100, \$7.00; 1000, \$57.00.
- Early Beatrice Peach, first-class; 100, \$21.00; 1000, \$150.
- Plum or Plum and Peach, 1 yr. 2 to 3 ft.; 100, \$12.50; 1000, \$100.
- Asparagus, Conover's Colossal, 2 yrs. 100, \$1.50; 1000, \$1.
- Rhubarb, choice seedlings; 100, \$1; 1000, \$6.
- free by mail; 100, \$1.50; 1000, \$12.50.
- Maple—Silver—12 to 14 feet; 100, \$10; 1000, \$60.
- Mt. Ash, 8 to 10 feet; 100, \$8; 1000, \$60.
- (Weeping), first-class; 10, \$1.50; 100, \$15.
- Mixed Tulips, flowering bulbs; 100, \$1.50; 1000, \$12.
- Evergreens—immense stock. Five Colored Fruit Plates, post-free, \$1; four Catalogues, 30 cents. Address **F. K. HENIX,** Bloomington, Ill.

CLAVERRACK College and Hudson River Inst., at Claverack, N. Y. Opens Sept. 7. **ALONZO FLOAK,** Ph. D., Pres.

TREES, Etc.

AUTUMN OF 1874.

We invite the attention of Planters and Dealers to our large and complete stock of

- Standard and Dwarf Fruit Trees.
 - Grape Vines, Small Fruits.
 - Ornamental Trees, Shrubs, Roses.
 - New and Rare Fruit and Ornamental Trees.
 - Evergreens and Bulbous Roots.
 - New and Rare Green and Hot House Plants.
- Small parcels forwarded by mail when desired.

Prompt attention given to all inquiries.

Descriptive and Illustrated Priced Catalogues sent prepaid on receipt of stamps, as follows:

- No. 1—Fruits, 10c. No. 2—Ornamental Trees, 10c.
 - No. 3—Greenhouse, 10c. No. 4—Wholesale, Free.
- Address **Establ'd 1840.**

ELLWANGER & BARRY,

Mount Hope Nurseries, ROCHESTER, N. Y.

ROCHESTER COMMERCIAL NURSERIES.

Trees ETC. If you wish to plant, send for our New Price List per doz., 100, 1000, Autumn 1874—and save all commissions. Try it. Address **W. S. LITTLE,** Rochester, N. Y.

Surplus Stock.

- PEACH**—1 year, fine, \$20 to \$60 per M.
- CHERRY**—2 year, fine, \$30 to \$150 per M.

An immense Stock for Nurserymen and Dealers—at lowest rates. See our

Surplus Stock List.

THE DINGEE & CONARD CO., Wholesale Nurserymen, West Grove, Chester Co., Pa.



WE offer for the fall of 1874 a complete stock of Trees and Plants. Our stock of Peaches, Plums and Cherries is the largest in the United States, and our list of new and rare fruits is always full. We are in a condition to offer advantages, and respectfully solicit correspondence. **THE HEIKES NURSERIES CO.,** Dayton, Ohio.

FREE

A Price List of **Trees, Shrubs, Small Fruits, Vines, Bulbs, and Winter Blooming Plants.**

10 Standard Pears, 1st class, for \$5.—100 Currants, Red or White, for \$5.—10 Concord Vines, bearing age, for \$5.—14 Winter Blooming Roses, for \$2.
A Premium Plant in every order. Send for Price List.
W. H. MOON, Morrisville, Pa.

ROSES.

The undersigned offers a quantity of Roses, unequalled in quality, best market varieties, from open ground.

Hardy Perpetuals, at \$15 per 100. Monthly and Teas, at \$12 per 100. Trade-list free on application.
J. M. KELLER Florist, 56th St. and 3d Ave. Brooklyn, N. Y.

PRICES REDUCED.

Large stock of all the new and popular PEACHES, EARLY BEATRICE, EARLY LOUISE, EARLY RIVERS, EARLY ALEXANDER, etc.

RANDOLPH PETERS,

Great Northern and Southern Nursery, Wilmington, Delaware.

CARNATION PINK PLANTS, For Winter Flowering;

Four best varieties, first quality, \$15 per hundred; \$125 per thousand.

CHAS. T. STARR, Avondale, Chester Co., Pa.

Calla Lilies, specially treated for winter blooming. 50 ets. each by mail; five for \$2.00.

Dutchess Nurseries. (Established 1863.)

Fall price-lists now ready. All kinds of nursery and greenhouse stock, Water and Croton Grape Vines, Downing Gooseberries, La Versailles Currants, and Am. Arbor Vite specialties.

APPLE SEEDLINGS.

Wild Goose and other Plum Trees, Peaches, Apples, and other nursery stock in large quantities.

PHILIP'S SPIRAL CORN HUSKING MACHINE

does its work thoroughly—stripping every ear and nubbing, large or small, completely of husks and silk.

EUREKA SELLS AT SIGHT. Does Two Men's Work. CORN HUSKER.

THOMAS T. TASKER, JR., STEPHEN P. M. TASKER.

MORRIS, TASKER & CO.

PASCAL IRON WORKS, Philadelphia. TASKER IRON WORKS, New Castle, Delaware.

THE PEOPLE'S Force Pumps.

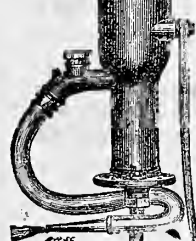

Awarded medal of American Institute over all competitors last fall. For the house and out of doors.

Certain parties, with the intent to profit by the well earned reputation of these pumps, the result of faithful manufacture, having imitated them, the Public are cautioned to look for the name "People's Pump."

W. S. BLUNT, 77 Beekman Street, New York.

Hope Seat Springs.

For Farm Wagons, Trucks, and Carts. The best and Easiest Riding Spring ever invented.

B. F. WELLS, Sole Agent, 47 Dey St., New York.

Table Knives and Forks of ALL KINDS,



And the "Patent Ivory" or Celluloid Knife. These Handles never get loose, are not affected by hot water, and are the most durable Knives known.

BLAKE'S PATENT STONE AND ORE BREAKER.

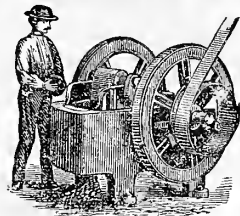

New Patterns, with Important Improvements and Abundant Strength.

For reducing to fragments all kinds of hard and brittle substances, such as STONE for making the most perfect McADAM ROADS, and for making the best CONCRETE.

Also for crushing Quartz, Flint, Emery, Corundum, Feldspar, Coal, Barytes, Manganese, Phosphate Rock, Plaster, Soapstone, etc.

BLAKE CRUSHER CO., NEW HAVEN, CONN.

Self-Propel-For Cripples

Can be easily in or out doors, using the use of State your weight for illustrated ferent styles and



Please mention this paper.

ling Chairs and Invalids

propelled, either by any one hand, and send stamp catalogue of different styles and

S. A. SMITH, No. 32 Platt St., N. Y. City.

NIAGARA FIRE INSURANCE COMPANY,

Capital Stock \$500,000. Cash value of Assets \$1,319,933. Total Liabilities 60,871.

BUILDING FELT.



This water-proof material, resembling fine leather, is for outside work (no tar substances used) and inside, instead of plaster.

C. J. FAY, Camden, N. J.

New York College of Veterinary Surgeons, INCORPORATED 1857.

Lectures for 1874 will commence about the middle of October and continue until the last of February, 1875.

GLASS CARDS Red, Blue, White, Plain & Transparent.

on 1 doz. for 50c. post pd. 3 doz. \$1. Must have agents every where. Outfits 25c. Samples 8c. F. K. SMITH, Bangor, Maine.

JERSEY CATTLE. ESSEX PIGS.

Dekin Ducks, illustrated in Sep. Agriculturist. Bronze Turkeys, descended from a pair weighing 62 lbs. Jersey Cattle, A. I. C. B. and Cotswolds, at low prices.

PURE BRED POULTRY for sale, all the leading varieties. For Price List &c., address W. E. STILL, Columbus, Wis.

Light Brahma Fowls for sale. From Felch, Tees, and other Strain. B. F. HOLBROOK, Natick, Mass.

Patent Chemical Metallic Paints,

GROUND IN OIL and MIXED, ready for use, in cans, kegs, and barrels. 50 cts., \$1, and \$1.50 per gallon. Also Liquid Slate and English Roof Paints.

MONEY. -Grangers and others, having money to loan, can obtain 12 per cent on good real estate security. Address H. L. WADSWORTH, Real Estate Agent, Litchfield, Minn.

AGENTS LOOK! - \$12 a day made selling Sellers Sharpener and other wares. Sample 25 cts. Catalogue free. T. J. HASTINGS & CO., Worcester, Mass.

WATERS' NEW SCALE PIANOS, SQUARE and UPRIGHT, are the best made.

WATERS' Concerto ORGANS cannot be excelled in tone or beauty; they defy competition. The Concerto Stop is a fine imitation of the Human Voice.

All are warranted for 6 years. PRICES EXTREMELY LOW for cash or part cash, and balance in monthly or quarterly payments.

THE PATENT ARION

PIANO-FORTE

Excels all others in Tone and Durability, and in Elegance of Finish they are unsurpassed.

These Pianos are used exclusively in the New York Conservatory of Music, and are recommended by the Profession and the Press throughout the United States.

Easy Payments for Best Organs.

THE MASON & HAMLIN ORGAN CO., winners of TWO HIGHEST MEDALS and DIPLOMA OF HONOR at PARIS, 1867, VIENNA, 1873, respectfully announce that they now offer their celebrated Cabinet Organs not only exclusively for cash, as formerly, but also on different plans of easy payments which, it is believed, afford purchasers unprecedented inducements.

BOOK AGENTS WANTED
 To sell the **NEW BOOK TELL IT ALL**
 By Mrs. Stenhouse, of Salt Lake City,—for 25 years the wife of a Mormon High-Priest. Introduction by MRS. STOWE. It tells of the "inner life," mysteries, ceremonies, secret doings, &c., of the Mormons. "As a wide-awake Woman sees them." It is actually overflowing with spicy revelations, humor, pathos, and good things for all. Ministers say "God speed it!" Enslaved women endorse it. *Everybody* wants it; and it is selling far and wide by thousands. Over 3,000 outfits were ordered in advance of publication, and Agents are selling 15 to 25 a day! We want 5,000 more Agents NOW—men or women. *(Ladies say this book goes like hot cakes)*—and we will mail **Canvassing Book and whole Outfit Free**, to anyone who will canvass. Our large descriptive pamphlets with full particulars, terms, &c., sent free to any one. Reader! send for them. Address, A. D. WORTHINGTON & Co., Hartford, Conn.

TO BOOK AGENTS.

We offer special and extra commissions to agents this fall. Our new books are just ready, and will stir up the reading public. We shall announce them soon. Full information sent on application, and exclusive territory given. No agent, old or new, should make arrangement for books without first negotiating with us. We can and will give agents better books, better terms, and enable them to make more money than any other house.

Wanted—5,000 men and women as local agents, and 1 experienced men and 2 women to act as General and Traveling Agents in the North and South.
 For information of books and agencies address
AMERICAN PUBLISHING CO.,
 Hartford, Conn.

GOOD NEWS

for book agents, and others desiring employment. New books by popular authors. **LITTLE FOLKS IN FEATHERS AND FUR** by OLIVE THORNE, and **THE WAYS OF WOMEN**, by Dr. J. V. C. SMITH. Splendidly gotten up. Beautifully illustrated. Nothing equal to them now offered to agents. **THE LIFE AND ADVENTURES OF KIT CARSON** is still selling rapidly. Over 20,000 already sold. \$30 a week easily made. **STOWE'S SELF-INTERPRETING FAMILY BIBLE**, the finest in the world. Circulars giving full and complete information sent free. Mention the books wanted.
 Address, **DUSTIN, GILMAN & CO.,**
 Hartford, Conn.

Four New Books!

(FOR AGENTS.)

OUR FIRST HUNDRED YEARS—12 monthly parts, 50 cts. each—2 parts now published.
Life and Public Services of Charles Sumner. 5th Edition. Revised and Enlarged.
Spirit of the Holy Bible.—Illustrated by the Old Masters. 600 Illustrations. Text in English, French, and German.
Maria Monk's Daughter.—An Autobiography. Send for terms, specimen pages, and inducements.
UNITED STATES PUBLISHING COMPANY,
 13 University Place, New York.

AGENTS wishing steady employment should canvass for **WONDERS OF THE GREAT DEEP.**
 A book of absorbing interest, filled with valuable information. Contains full accounts of Submarine Diving, Ocean Telegraphy, Arctic Discoveries, Whale Fisheries, &c., &c. Selling rapidly; price low. Elegantly illustrated; handsomely bound.
 Quaker City Pub. Co., Philadelphia.

New Subscription Books.

CANVASSING AGENTS WANTED FOR THE FOLLOWING IMPORTANT WORKS.
 1.
 A New Work of Intrinsic Value.
THE LIFE OF
SAMUEL F. B. MORSE, LL. D.
 INVENTOR OF THE
Electro-Magnetic Recording Telegraph.
 By SAMUEL IRENEUS PRIME, S. T. D.
 President of the N. Y. Association for the Advancement of Science and Art.
 One Octavo Volume, 783 Pages. Price in Cloth, \$5; Sheep, \$6; Half Turkey, \$7.50.

2.
Personal Reminiscences, Anecdotes, and Letters of
GEN. ROBERT E. LEE.
 By REV. J. WM. JONES, D. D.,
 Formerly Chaplain Army Northern Virginia, and of Washington College, Virginia.
 With twenty fine illustrations on Steel and Wood.
 (Published by authority of the Lee Family and of the Faculty of Washington and Lee University.)
 Price, in Cloth, \$3.50; Sheep, \$4.50; Half Turkey, \$5.50; Full Turkey, \$7.50.

Order Books for the above two works, with specimen pages—showing type, illustrations and binding—are now ready, and will be supplied, post-paid, on receipt of \$1.50 for each—the amount to be refunded as soon as an order for not less than ten copies is received. Applications for exclusive agencies for counties should be made at once, naming first, second, and third choice of Territory. For further particulars, apply to
D. APPLETON & CO., Publishers,
 549 and 551 Broadway, N. Y.

LIVINGSTONE IS DEAD.
 For 30 years millions have INTENTLY watched the PERILOUS struggles and GRAND achievements of this WORLD RENOWNED Hero, and now EAGERLY desire the Complete **Life History** which unfolds also the WEALTH and CURIOSITIES of a WILD and WONDERFUL country. It is NOW READY and SELLING to beat everything. More AGENTS WANTED AT ONCE. For Particulars of this, our super NEW illustrated BIBLES, and OCEAN'S STORY, address
HUBBARD BROS., Publishers,
 Philadelphia, Boston, or Cincinnati.

Livingstone Still Lives
 In his works. **AGENTS WANTED** for the only complete book—over 800 pages; over 100 full page engravings. Also for **THE FROZEN ZONE AND ITS EXPLORERS.** A full record of all Arctic Expeditions, including that of the Polaris. Both books are most valuable and popular, and very salable. For Agency address
COLUMBIAN BOOK CO.,
 Hartford, Conn., or Chicago, Ill.

AGENTS WANTED FOR THE CENTENNIAL GAZETTEER OF THE UNITED STATES.
 Showing the gigantic results of the "First 100 Years of the Republic." Agents make \$100 to \$500 per month. Send for circular.
ZIEGLER & M'CURDY,
 Philadelphia, Pa.; Springfield, Mass.

WANTED AGENTS.—Worthy the special notice of old and experienced canvassers. "COLE'S VOYAGE OF LIFE,"—line engraving—childhood, youth, manhood, old age. Sold by subscription only. Price reduced to suit the times. Nothing like it ever offered to the American public. Rare chance and inducements.
 Address **B. B. RUSSELL, Publisher, Boston.**

The Young Housekeeper's Friend,
 by Mrs. Cornelius. The best Cook Book and guide for the various duties of the household published. Price \$1.50. Interleaved \$2.25. Sent by mail on receipt of price.
THOMPSON BROWN & CO.,
 Boston, Mass., Publishers.

FANCIER'S JOURNAL A Weekly devoted to Fowls, Pigeons, Rabbits, Dogs, Song Birds, etc. Send stamp for Specimen Copy.
JOS. M. WADE, Philadelphia, Pa.

Kimball's New Method for Reed Organ.
 The latest, largest, and by far the best and most complete instruction book for Reed Organs. Used exclusively by the best teachers. Contains complete instructions and a large amount of beautiful Reed organ music. **Kimball's New Method** contains 163 large quarto pages, and is sold by all music dealers, or a copy will be mailed, post-paid, on receipt of \$2.50, by the publishers.
S. BRAINARD'S SONS, Cleveland, Ohio.

ALL FOR ONE DOLLAR.
 Wine, Wife and Song..... by Strass.
 A happy Circle Gallop..... do, do, do.
 La Filie de Madam..... Angot-Waltz.
 With Steam, Polka..... Ed. Strass.
 Let's be Gay, Waltzes..... J. Strass.
 Regatta Veneziana..... F. Liszt.
 La Bella Louise, Quickstep..... Rublee.
 Where the Cherry Blossom..... Strass.
 Who is at my Window..... Osborne.
 Annie Dear..... Abt.
 Why throw away money on high-priced Music when you can select from our Catalogue of 700 pieces? Any 20 Half-Dime, or 10 of Dime Series, mailed on receipt of One Dollar. Sold by all booksellers, and can be ordered through any newsdealer. Send stamp for Catalogue.
BENJ. W. HITCHCOCK, Publisher,
 439 Third Avenue, New York.

New Church Music Book,
For 1874—1875.
THE LEADER!
 By H. R. PALMER, assisted by L. O. EMERSON.
 Just issued and ready for sale. Its success already assured. Its price is a return to ante-war Church Book rates, and its contents new, fresh, and cannot fail of winning a hearty endorsement from choir masters—the musical profession and the musical public. Specimen pages free on application.
PRICE \$1.38. \$12.00 PER DOZ.

RIVER OF LIFE.

FOR SABBATH SCHOOLS.
 A sale of over 30,000 in less than one year attests the merit of this Book. The Publishers are confident that no better Sabbath School Book has been published in years, and none given such entire satisfaction.
Price 35 cts. B'ds; \$3.60 per doz.; \$30 per 100.

THOMAS' SACRED QUARTETS and ANTHEMS.
 This day published.—Has been many years in preparation and will be welcomed by all the lovers of Mr. Thomas' Sacred Music—and who is not one? As a Quartet Book for Choirs, it will be found indispensable.
Price in Boards, \$2.50. Cloth, \$3.00.
OLIVER DITSON & CO., Boston, CHAS. H. DITSON & CO., 711 B'way, New York.

\$2500 A YEAR
 made with our **GRAND COMBINATION PROSPECTUS.**
 Represents 50 different books. Agents say this is the **BEST THING EVER TRIED.**
 The Books sell themselves in every family, and good men can make a business for life in one county. Agents Wanted on these and our magnificent Editions of **Family Bibles.** Full particulars free on application. Address
JOHN E. POTTER & CO., Publishers, Philadelphia.

FANCIER'S JOURNAL A Weekly devoted to Fowls, Pigeons, Rabbits, Dogs, Song Birds, etc. Send stamp for Specimen Copy.
JOS. M. WADE, Philadelphia, Pa.

THE FRUIT RECORDER AND COTTAGE GARDENER

3 MONTHS FREE.

will be sent FREE for 3 months to all who will pay postage at office of delivery. We do not ask any one to subscribe for our paper until they know what they are to get. *It speaks for itself.* Price only \$1 per year. Our **Small Fruit Instructor** is a work of 64 pp. that tells in simple language just how to grow fruits in abundance for home use or market. Price 25 cts., post-paid.

A. M. PURDY, Palmyra, N. Y.

Every FARMER and STOCK RAISER, and EVERYBODY that keeps a HORSE, a COW, POULTRY, SHEEP or SWINE—whether he lives in CITY, TOWN, or COUNTRY, wants the

Live Stock Journal.

Monthly. \$1.50 per year. In its 5th Volume. Beautifully illustrated. The best instructor upon every class of Live Stock. National—giving equal attention to the Stock Interest of every State. Treats, by practical writers, upon the Farm, the Dairy, Horses, Cattle, Sheep, Swine, Poultry, Bees, Fish and their diseases. Specimen copy, 10 cents.
 Address **LIVE STOCK JOURNAL CO., Buffalo, N. Y.**
 Good pay to agents. Agents wanted at every post-office.

Herald of Health.

This monthly is devoted to the culture of the body and mind; to rearing healthy and beautiful children; to the recovery of health without drugs; to the improvement of the physique; and to showing people how to live so as to be healthy, happy, and make the most of life. The Scientific American says: "It contains more sensible articles than any monthly that comes to our notice." \$2.00 a year, with a premium of the complete works of Shakspeare, in one volume of over 1,000 pages and 36 illustrations.
WOOD & HOLBROOK, 13 and 15 Light St., New York.



FOUNTAIN PUMP.
GARDEN ENGINE and FIRE EXTINGUISHER.—For Washing Windows, Carriages, etc. Protects Buildings from Fire, and Trees, Vines, etc., from Insects. Throws water 50 ft. Easily carried. No Dwelling, Country Home, or Factory should be without the Fountain Pump. Send for large Illustrated Circular. **J. A. WHITMAN, Sole Proprietor and Manufacturer, Providence, R. I.**

THE PULSOMETER.



The simplest, most durable, and effective steam pump now in use. Will pump gritty or muddy water without wear or injury to its parts. It can not get out of order.
C. HENRY HALL & CO.,
 20 Cortlandt Street, New York City.
 BRANCH DEPOSITS:
 104 Sudbury St., Boston, Mass.
 1327 Market St., Philadelphia, Pa.
 59 Wells St., Chicago, Ill.
 South Western Exposition, New Orleans, La.
 811 and 813 North Second St., St. Louis, Mo.

ARE YOU GOING TO PAINT?

OVER 200,000 HOUSES

PAINTED WITH THE
Averill Chemical Paint.

White and all the fashionable shades mixed ready for use and sold by the gallon.

EXTRACTS FROM OUR LETTERS.
 Hon. JAS. NEGRLEY, Pittsburg, Pa.: "Altogether I find the 'Averill' the cheapest and best."
 PETER HENDERSON, Esq.: "The 'Averill' has proved superior to lead and oil."
 C. W. SPOONER, Treas., Cordage Co., Plymouth, Mass.: "The 'Averill Chemical' has proved good."
 C. A. ALLYN, Esq., Palmyra, N. Y.: "The 'Averill Paint' is as bright to-day as when applied three years ago."

Hundreds of testimonials from owners of the finest residences in the country, with Sample Card of Colors, furnished free by dealers generally, and by the

AYERILL CHEMICAL PAINT CO.,
 32 Burling Slip, New York; or 132 East River St., Cleveland, Ohio.

AMERICAN AGRICULTURIST.
 ORANGE JUDD COMPANY, Publishers, 245 Broadway, N. Y.
 ANNUAL SUBSCRIPTION Terms (always in advance):
 \$1.50 each for less than four copies: Four to nine copies, \$1.25
 each: Ten to nineteen copies, \$1.20 each: Twenty copies
 and upward, \$1 each. 10 cents extra must be forwarded
 with each subscription, for payment of postage for 1875.
 Papers are addressed to each name.
 ☞ Either English or German Edition, at these prices.

NOW
For 1875,
Beginning TO-DAY.
 OUR
Premium List.
New Things,
Good Things,
Useful Things,

That can be obtained **without**
money and with a little effort by

ANYBODY.

Once more the Publishers of the *American Agriculturist* present their friends and readers with a new Premium List full of good things. The experience of many years has taught them that such offers as are here made, of **very large returns for a very little labor**, never fail to be highly appreciated.

Now, reader, here is something for You. Look over the attractive List of Premiums, and especially the descriptions of them. There are many things among these that you would like to possess without having to pay the money for them. Here are *Pocket Microscopes, Gold Pens, Revolving Pencils, Silver-Plated Ware, Knives and Forks, Pocket Knives, Beautiful Toys for the Children, Melodeons, Pianos, Sewing Machines, Knitting Machines, Books, etc., etc., etc.* You have only to make your choice, and then take hold of this pleasant work of getting a club of subscribers sufficient to obtain it. More than **Fifteen Thousand Men, Women, and Children**, in almost all stations and pursuits, have successfully done this, and at least fifteen thousand

may do it **now**. You may as well be one of the fortunate ones, as anybody else. It only needs a little enterprise and the will—with the *will* there will be a *way*. And **now** is the **best time** to begin. As elsewhere announced, every subscriber coming in this month gets this Journal from November to the end of 1875, at the cost of one year's subscription, and that will help our premium collectors very much. There is room in every neighborhood for several premium clubs. Everybody ought to have the paper; its plain, practical information will put money in most people's pockets, and save multitudes from swindlers, and from unprofitable investments of funds and time. So while you are aiding to push the paper into the people's hands, you are engaged in "*doing Good as well as in Making Money.*"

The *American Agriculturist* is one of the best papers to canvass for in the world. Its many beautiful illustrations, its interesting and instructive reading matter, its Household and Boys and Girls' Departments, its intrinsic value in every way, secure hosts of friends wherever it is seen and known. Read three extracts as specimens from many hundreds of persons who have received our Premiums.

"June 1, 1874.

"I am very much pleased with the premiums, [Dictionary and Gun], and could sell them now at a fair price, but can't think of parting with either, although I am not much of a hunter. My watch that I received over two years ago, is an excellent time-keeper. I feel encouraged to do more than ever for the *Agriculturist*, if I should live next year."

"June 26, 1874.

"Premium [Pocket Rifle] received. Thanks. It is beautiful."

"June 24, 1874.

"Please accept thanks for Carver and Fork, which you sent me as Premium for getting a club to *American Agriculturist*. I find them as represented—genuine articles."

Now, what has been done by thousands to their great profit and delight, **You too may do. TRY IT.**

Explanatory Notes.

N. B.

Read and carefully Note the following Items: (a) All subscribers sent by one person count, though from one or a dozen different Post-offices. But....(b) Tell us with each name or list of names sent, that it is for a Premium....(c) *Send the names as fast as obtained*, that the subscribers may begin to receive the paper at once. You can have any time you wish up to July 1st, to complete your list....(d) Send the exact money with each list of names, so that there may be no confusion of money accounts....(e) Old and new subscribers all count in premium clubs, but a portion, at least, should be new names; it is partly to get these that we offer premiums to canvassers....(f) Specimen Numbers, etc., will be supplied free, as needed by

canvassers, but they should be used carefully and economically, and where they will *tel...* (g) Remit money in Checks on New York Banks or Bankers, payable to order of Orange Judd Company, or send Post-office Money Orders. If neither of these is obtainable, Register Money Letters, affixing stamps both for the postage and registry; put in the money and seal the letter in the presence of the Post-master, and take his receipt for it. Money sent in any of the above ways is at our risk; otherwise it is not.

[In the following table is given the price of each article, and the number of subscribers required to get it *free*, at the regular rates, \$1.50 a year and also at the club rates of \$1 a year.] **Description of Premiums on next page.**

Table of Premiums and Terms
For Volume 34—(1875).
BEGINNING NOW.
Open to all—No Competition.

No.	Names of Premium Articles.	Price of Premiums	Number of Subscribers required	at or at \$1.50 \$1.
1	Tea Set (Lucius Hart Man'fact'g Co.)	\$50 00	66	225
2	Ice Pitcher.....(do. do. do.)	\$16 00	24	80
3	Casters.....(do. do. do.)	\$9 00	17	54
4	Tea Tray.....(do. do. do.)	\$12 00	19	65
5	Revolving Butter Cooler (do. do.)	\$3 00	16	52
6	One Dozen Teaspoons (do. do.)	\$6 00	19	65
7	One Dozen Tablespoons (do. do.)	\$12 00	19	65
8	One Dozen Table Forks (do. do.)	\$12 00	19	65
9	Child's Cup.....(do. do.)	\$2 75	7	27
10	Child's Knife, Fork & Spoon (do.)	\$5 00	12	37
11	Moore's Floral Set (Moore Man'g Co)	\$1 00	3	...
12	Gold Pen, Sil. Case (Geo. F. Hawkes)	\$3 25	8	30
13	Gold Pen and Silver Case (do. do.)	\$5 00	12	37
14	Gold Pen, Handle gold-tipped (do. do.)	\$6 00	15	45
15	Ladies' Gold Pen & Rubber Case (do.)	\$6 00	15	45
16	Paragon Pat. Revolving Pencil (do.)	\$1 50	4	...
17	Paragon Pat. Revolving Pencil (do.)	\$3 00	8	30
18	Payson's Indelible Ink.....	75	3	...
19	Child's Carriage..... (C.W. F. Dare)	\$20 00	30	102
20	Child's Self-operating Swing (do. do.)	\$4 00	9	32
21	Doll's Cottage Chamber Set (do. do.)	\$5 00	12	37
22	Crandall's Building Blocks.....	\$2 00	5	20
23	Crandall's Masquerade Blocks.....	\$1 00	3	...
24	Crandall's Acrobats.....	1 00	3	...
25	Pocket Tool Holder (Miller's Falls Co.)	\$1 00	3	...
26	Bracket Saw.....(do. do.)	\$1 25	4	...
27	"Peoples' Pump" (W. S. Blunt).....	\$12 00	19	65
28	Non-freezing Out-door Pump (do.)	\$21 00	32	110
29	Excelsior Pocket Microscope (Vulcan- ite Optical Instrument Co.)	\$2 75	7	27
30	Two. "Pocket Soap-Bubble Toy" (Bissell)	\$1 00	3	...
31	Turn-table Apple Parer (D. H. Goodell)	\$1 00	3	...
32	China Apple Corer & Slicer (do.)	\$1 00	3	...
33	Family Cherry Stoner.....(do.)	\$1 00	3	...
34	Knives and Forks (Patterson Bros.)	\$15 25	22	75
35	Knives and Forks (do. do.)	\$19 00	28	97
36	Carver and Fork (do. do.)	\$4 00	10	34
37	French Cook's Knife, Fork, and Steel	\$4 00	10	34
38	Pocket Knife (Meriden Cutlery Co.)	\$1 50	4	...
39	Pocket Knife (do. do.)	\$2 00	6	22
40	Pocket Knife (do. do.)	\$2 75	7	27
41	Ladies' Pocket Knife (do. do.)	\$2 00	6	22
42	Mutton or Parvo Knife (do. do.)	\$3 50	8	30
43	Garden Seeds & Flower Tub (select'n)	\$2 00	6	22
44	Automatic Family Knitting Machine (N. Y. Knitting Machine Co.)	\$35 00	50	162
45	Sewing Machine (Secor).....	\$62 00	70	270
46	Beckwith Portable Family Sew'g Mach	\$20 00	30	100
47	Washing Machine (Dobbs).....	\$14 00	21	70
48	Clothes Wringer (Best—Universal)	\$7 00	15	47
49	Melodeon. 4-occe. (G. A. Prince & Co.)	\$30 00	105	320
50	Piano. Stein and Co. (Steinway & Co.)	\$650 00	625	1650
51	Watch (American Watch Co.)	\$40 00	50	185
52	Breech-loading Pocket Rifle.....	\$16 00	24	80
53	Double-bl. Gun (Edwin S. Harris)	\$90 00	46	150
54	Charles Pratt's Astral Oil (1 can, 5 gal.)	\$2 85	7	27
55	Cahoon's Broadcast Seed-sower.....	\$10 00	18	58
56	Hand Cultivator & Weeder (Comstock)	\$9 25	17	54
57	Family Scales (Fairbanks & Co.)	\$14 00	21	70
58	Worcester's Great Illustrated Dictionary	\$10 00	18	58
59	Any back Volume Agriculturist	\$1 75
60	Any Two Back Volumes do.	\$3 50
61	Any Three do. do. do.	\$5 25
62	Any Four do. do. do.	\$7 00
63	Any Five do. do. do.	\$8 75
64	Any Six do. do. do.	\$10 50
65	Any Seven do. do. do.	\$12 25
66	Any Eight do. do. do.	\$14 00
—(Each add'l Vol. at same rate.)				
67	Eighteen Vols. XVI to XXXIII.	\$31 50	42	145
68	Any Back Vol. Agriculturist	\$2 50
69	Any Two Back Volumes do.	\$5 00
70	Any Three do. do. do.	\$7 50
71	Any Four do. do. do.	\$10 00
72	Any Five do. do. do.	\$12 50
73	Any Six do. do. do.	\$15 00
74	Any Seven do. do. do.	\$17 50
75	Any Eight do. do. do.	\$20 00
76	Any Nine do. do. do.	\$22 50
—(Each add'l volume at same rate)				
77	Eighteen Vols. XVI to XXXIII.	\$35 00	42	192
78	A \$10 Library (Four Choice.)	\$10 00	18	58
79	A \$15 Library do.	\$15 00	24	85
80	A \$20 Library do.	\$20 00	31	106
81	A \$25 Library do.	\$25 00	38	125
82	A \$30 Library do.	\$30 00	44	144
83	A \$35 Library do.	\$35 00	50	162
84	A \$40 Library do.	\$40 00	56	177
85	A \$45 Library do.	\$45 00	62	192
86	A \$50 Library do.	\$50 00	68	207
87	A \$60 Library do.	\$60 00	80	237
88	A \$75 Library do.	\$75 00	100	282
89	A \$100 Library do.	\$100 00	125	360
90	A Choice of Good Books. (See Description.)	100 00	125	360

☞ Every Premium article is **new** and of the very **best** manufacture. No charge is made for packing or boxing any article in our Premium List. The Premiums, **Nos. 12 to 18, 22 to 26, 29 and 30, 38 to 43, and 59 to 90, inclusive**, will each be delivered **FREE** of all charges, by mail or express (at the Post-office or express office nearest the recipient) to any place in the United States or Territories.—The other articles cost the recipient only the freight after leaving the manufactory of each, by any conveyance desired. See **Description of Premiums on next Page.** [OVER.]

Descriptions of Premiums.

(For number of Subscribers required, see Table, page 393.)

No. 1.—A splendid Tea Set.—This Premium is one of the most elegant ever offered. There are six pieces, viz.: *A Coffee-Pot, Teapot, Sugar Bowl, Creamer, Slop Bowl, and Spoon-Holder*—all of beautiful, uniform pattern, new style, with raised and embossed figure work. They are not the common silver-washed articles, but the best *triple plate*, the foundation being white metal, so as not to show, even when the heavy silver coating may chance to be worn off in any spot by long, hard usage.—These sets are made by the **Lucius Hart Manufacturing Co.**, of Nos. 4 & 6 Burling Slip, New York City, and are warranted by them to be of the *best triple plate*; and each piece bears their stamp. The late Mr. Hart, "the veteran Sunday-School man," was engaged in the same place and business for nearly a quarter of a century. We knew him and his work many years, and took pleasure then in commending and guaranteeing its value to be as represented. We believe the Company which bears his name is fully sustaining his reputation. The amount of silver upon plated ware depends wholly upon the will and integrity of the manufacturer. We could give nearly as good-looking plated ware for less than half the money, but it would not be worth a quarter as much for real use.

No. 2.—Ice or Water Pitcher.—A large, highly ornamental article. It is of the same metal, plating, etc., and by the same makers as No. 1. For 32 subscribers at \$1.50 each, we will include a round Salver of pattern to correspond (value \$5); we add, for 44 subscribers, a large 16-inch oval Salver (value \$14), large enough for two goblets with the pitcher; or for 51 subscribers, the Pitcher, large Salver, and a pair of beautiful Goblets, silver-plated without, and gilded within (value \$37). This complete set is exceedingly desirable, though the Pitcher alone, or that and the small Tray, or Salver, will answer a good purpose, both for *use and ornament*.

No. 3.—Casters.—A handsome pattern, richly chased, of this useful and necessary article for every dining table. By the same makers as No. 1.

No. 4.—Cake Basket.—An elegant pattern, oval-shaped, nicely chased—a very taking, useful, and beautiful table ornament. From same makers as No. 1.

No. 5.—Revolving Butter-Cooler.—This is a really good and useful article. It is so arranged that a very little ice in the holder under the plate will keep butter cool and fresh for a long time on the table, even in the hottest weather. The cover revolves underneath the plate for use, and over for protection. The whole is in four pieces, which can all be taken apart for washing. From same house as No. 1.

No. 6.—One Dozen Tea-Spoons.—**No. 7.—One Dozen Table-Spoons.**—These are "figured tips," Olive-leaf Pattern, all of the same metal, plating, etc., and from the same makers as No. 1. They are far *cheaper* than anything we have found at half the price, and are well worth working for.

No. 8.—One Dozen Table-Forks.—The same description and remarks apply to these as to No. 1. We select as premiums only such articles as we can warrant in quality and price. All these articles come from the **Lucius Hart Manufacturing Co.**

No. 9.—Child's Cup.—A beautiful gift for the little *one-year-old*. It is made by the **Lucius Hart Manufacturing Co.** Triple-plated on the outside and *gilded* on the inside. It never breaks, and will last for many years—indeed, be a life-keepsake.

No. 10.—Child's Knife, Fork, and Spoon.—This also is a beautiful gift for a child. The articles are triple-plated, finely figured with ivy-leaf pattern, and put up in a handsome silk-lined morocco case. From the same house as No. 9.

No. 11.—Moore's Floral Set.—This is a beautiful Premium—a complete set of **Ladies' or Children's Garden Tools** for the cultivation of flowers, consisting of a Floral Hoe, Spade, Fork, and Rake. They are made of the best steel and iron, with finely polished hard-wood handles, light, durable, and highly finished, and each set inclosed in a box. They will be found very convenient in the garden and greenhouse—*useful* pleasing toys for the little folks. Made by the **Moore Manufacturing Company**, Kensington, Ct.

Nos. 12, 13, 14.—Gold Pens: *with ever-pointed Pencils, in extension, coin-silver cases.*—Premium No. 12 contains the best No. 4 Gold Pen; and No. 13 the best No. 6 Gold Pen, which is the same style, but larger. No. 14 contains No. 7 Gold Pen, in Gold-tipped Ebony Holder. Each pen will be sent in a neat leather case by

mail, post-paid. These pens are made by **Geo. F. Hawkes**, No. 66 Nassau St., and have obtained an excellent reputation. We have known the maker and his goods for many years, and can recommend them.

No. 15.—Ladies' Fine Gold Pen, in Rubber Case, Gold Mounted, with Screw Extension, and Gold Ever-pointed Pencil. A beautiful present for a lady teacher or friend. Same maker as No. 12.

Nos. 16, 17.—Paragon Patent Revolving Pencil.—This is a beautiful Pocket Pencil, which is extended or closed by pulling or pressing the head. They are made with great care, and every Pencil warranted to work perfectly. They are gold-plated, and will last for years. We offer two patterns, one for ladies, with ring for chain, at \$1.50 each, and one of heavier and firmer plate, at \$3. Same maker as No. 12.

No. 18.—Payson's Indelible Ink, and Briggs's Marking-Pen Combination.—Payson's Indelible Ink is too well known to need further commendation. It is almost indispensable in the family. Briggs's Marking-Pen has been before the public for fifteen years, and is justly celebrated for all kinds of marking, and particularly for writing upon coarse fabrics. The Pen and Ink are put up in a neat case, being thus portable, always ready for use, and protected from loss or injury by evaporation or breakage.

No. 19.—Child's Carriage, or Perambulator.—An elegant carriage, handsomely finished, upholstered with reps, has full plate tinned joints, handle tips, side lights, dash rail, panel body, and carpet on the bottom. These carriages are from the well-known manufacturer **C. W. F. Dare**, 47 Cortlandt St., N. Y.

No. 20.—Child's Patent Propeller or Self-Operating Swing.—A pleasing thing for a little boy or girl. The seat of the swing is upholstered with enameled cloth, showily painted, and hooks and all complete accompany it. When it is hung up, the hooks overhead to which the lever ropes are attached, must be set about one foot in front of the hooks to which the main ropes are attached. A child is delighted with being able to swing himself. From **C. W. F. Dare**, 47 Cortlandt St., New York.

No. 21.—Doll's Cottage Chamber Set.—A most attractive gift for a little girl. Eight pieces of furniture prettily painted: Bedstead (size 11½ × 18 inches), bureau, table, commode, towel-rack, two chairs, one rocking-chair. From **C. W. F. Dare**, 47 Cortlandt St., New York.

No. 22.—Crandall's Improved Building Blocks furnish a most attractive amusement for children. Churches, Dwellings, Barns, Mills, Fences, Furniture, etc., in almost endless variety, can be built with them, and the structures remain so firm as to be carried about. For developing the ingenuity and taste of children they are unequalled. The Blocks are put up in neat boxes, accompanied by a large illustrated sheet giving various designs of buildings, etc. This is one of the most successful toys ever invented.

No. 23.—Crandall's Masquerade Blocks.—These are put up in boxes; the blocks in each box will make, by various combinations, **300 different pictures** in brilliant colors. They are not injured by washing, and afford endless amusement for children. They are beautiful gifts for the little ones.

No. 24.—Crandall's Acrobats.—The most attractive, amusing and wonderful toy of the age. Children everywhere, who have seen the Acrobats, are delighted with them. Thousands of figures can be made from the pieces in a single box. The pieces are variously colored, and there is no end of fun in a box of them.

No. 25.—Pocket Tool Holder.—Every boy will be glad to get hold of this Premium. In a maple handle, which is hollow, with a lignum-vitæ head, are packed twenty miniature cast steel tools, either of which may be adjusted to the handle. It will also hold anything from an 8 inch mill file to a cambric needle. Made by the **Miller's Falls Manufacturing Co.**, 78 Beekman St., New York.

No. 26.—Bracket Saw.—Although this is a little thing, size of frame being about 6 × 12 inches, it is sufficient for the manufacture of very many ornamental and useful articles, as Book Rests, Brackets, Boxes, etc., which the ingenuity of any person, young or old, may devise. The frame is rosewood highly polished, and the saws of tempered steel, four of which, with Designs and Directions, are sent with the frame. Made by the **Miller's Falls Manufacturing Co.**, 78 Beekman St., New York.

No. 27.—"People's Pump."—What every country family needs. An in-door Force Pump for

1½ inch Suction Pipe; capacity 15 to 18 gallons per minute. These pumps are tested to 150 pounds pressure, and will throw water from a hose pipe 50 feet high, and 80 feet horizontally. Being operated by a side shaft entering through the air chamber, there is no piston rod to wear out brass stuffing box as in other pumps. They are among the most powerful, simple, and durable pumps to be had. The case with which any part can be renewed in case of accident, or access had to the interior for repairs, commends them for greenhouses, farmers, and stockmen, as well as for city use. Awarded Medal of American Institute, as the Best Force Pump of all exhibited, Nov. 15th, 1873. None genuine without "People's Pump, Patented Aug. 31st, 1869," cast on the lid. Send for circular to **W. S. Blunt, Manufacturer**, 77 Beekman St., New York, and secure a *free* one for your own use, (or for sale at \$12.) by simply sending us 19 subscribers.

No. 28.—Non-Freezing Outdoor Force Pump.—This is another style of the popular "People's Pumps," and by the same manufacturer. The description of Premium No. 27, is also applicable to this, and while that is designed for in-door, this is for outdoor service. For seven additional subscribers at \$1.50 each, we will send, with either of the above pumps, 4 feet of *hose, couplings, and brass hose-pipe*, price \$3.

No. 29.—Excelsior Pocket and Dissecting Microscope.—This is a beautiful little instrument, the application of which to the examination of numberless objects, makes it most interesting to child or man, whether in the country or city, on the farm, in the workshop or warehouse. The microscope here offered is supplied with *Three Lenses*, and is packed in a neat case for the pocket. The microscope was patented by J. J. Bausch of Rochester, N. Y. It is manufactured by the **Vulcanite Optical Instrument Co.**, and is for sale by dealers in optical instruments generally. One of these, which reveals many interesting things unseen by the unaided eye, ought to be in *every* family, and here is a chance to obtain one *free*, by simply sending us seven subscribers, every one of whom will get his money's worth in the paper, and, should you choose to be accommodating, may also enjoy the loan of your microscope.

No. 30.—Pocket Soap Bubble Toy.—Two of these Toys, which greatly please all the boys and girls, will be given for this Premium, and almost any child can readily get 3 subscribers at \$1.50 each, and thus secure one of these for himself and another to give away. It may be carried in the pocket, and can be used for blowing bubbles in-doors or out. Directions accompany each one. Manufactured by **S. B. Bliss**, 34 Barclay St., New York.

No. 31.—Turn-table Apple Parer, Improved.—**No. 32.—Climate Apple Corer and Slicer.**—**No. 33.—Family Cherry Stoner.**—All the above little machines, which are most useful in every household where apples and cherries are to be cared for, are manufactured by **D. H. Goodell**, Antrim, N. H., and 99 Chambers St., New York. We have never seen the work, for which these machines were contrived, more rapidly or better done than they will do it. The Apples are pared, cored, and sliced with the greatest facility, and the Cherries are readily relieved of their stones, leaving the fruit in good shape. Only three subscribers each are required to get one or more of these.

Nos. 34, 35, 36.—American Table Cutlery.—We are glad to be able to offer really good articles of American manufacture, such as are competing successfully with the best foreign make. **Messrs. Patterson Bros.**, 27 Park Row, who supply us with these articles, are also importers of English goods. They recommend these Knives, manufactured by the **Meriden Cutlery Co.**, as equal to any Cutlery in the market, and their recommendation is a guarantee wherever they are known. We offer two kinds of Knives, and three sizes on each kind. No. 34 have Rubber Handles, which are actually boiling-water proof, so that, if they were accidentally to remain in it for several minutes, or even hours, they would not be injured. The Blades are of the best steel, and warranted. Dessert size, with Forks, sold at \$15.25. . . . For 27 subscribers at \$1.50, or 90 at \$1, we will give either the medium size or the table size, sold at \$16.75. No. 35 have Ivory Handles, are selected with great care, have Steel Blades, and are beautiful goods. Dessert size, with Forks, sold at \$19.00. . . . For 33 subscribers, at \$1.50, or 110 at \$1, we will send the medium size, sold at \$22.00. . . . For 35 at \$1.50, or 116 at \$1, we will send the Table size, sold at \$23.00. The Forks, which accompany these Premiums, Nos. 34 and 35, are made of genuine Albata, and warranted *double-plated with coin-silver*. These Forks are furnished to us by Messrs. Patterson Bros. . . . The Carving-Knife and Fork are made by **The Meriden Cutlery Co.**, with the best Ivory, balanced Handles.

No. 37. — French Cook's Knife, Fork, and Steel.—This is a long (10 in.) thin Knife, with Pat. Rubber Handle, made of the best steel, and for use rather than ornament; and it is really pleasing to see how easily it slips through a joint of beef. The fork and steel are made to match. It would save many wry faces, and perhaps hard words, were it in general use. Made by the **Meriden Cutlery Co.**

Nos. 38, 39, 40, 41. — Pocket Knives.—HERE'S FOR THE BOYS AND GIRLS!—These Premiums are among the most pleasing and useful that we have ever offered. Every boy, and girl too, wants a pocket knife. We give them an opportunity to obtain a most valuable one for merely a little effort. These knives are furnished by the **Meriden Cutlery Co.**, 49 Chambers Street, New York, whose work is equal to any done in this country or Europe. No. 38 is a neat, substantial Knife, with three blades and buck-horn handle. No. 39 is a still finer article, with four blades and pearl handle. No. 40 is an elegant Knife, with five blades and shell handle. No. 41 is a Lady's Pocket Knife, a beautiful article, with four blades and shell handle.

No. 42. — Multum in Parvo Pocket Knife.—**Boys, Read this.**—This is a most attractive as well as useful Premium, from the **Meriden Cutlery Co.**, 49 Chambers Street, New York. It comprises, in one knife-handle, a large and a small blade, a screw-driver, a saw, a strong hook, a nut-cracker, a brad-awl, a gimlet, a corkscrew, a pointer, a slim punch, tweezers, and, in addition to this, it can be used for various other purposes which will at once suggest themselves to any smart boy or man. It is a pocketful of tools weighing but two ounces. The knives will be sent anywhere in our country, post-paid.

No. 43. — Very Choice Garden Seeds and Flower Bulbs.—We have taken special pains to have prepared by **Messrs. B. K. Bliss & Sons**, 34 Barclay Street, New York, (whose seed establishment is well known as one of the best in the country,) a list of Seeds and Bulbs of the *very choicest kinds*, and the most useful varieties. Though some are rare (and costly), all have been tested and found excellent. Here is an opportunity to obtain a valuable assortment of seeds, as this premium allows you to select from the list below any that may be desired, to the amount of **two dollars**. If more seeds are wanted, it is only needful to secure two or more of the premiums, and select seeds accordingly. *All delivered free:* 1 pint New Dwarf Wax Beans, 50c.; 1 pkt. Beet, New Egyptian Blood Turnip, 15c.; ½ ounce of Perpetual Spinach, 25c.; 2 oz. of Lane's Improved Imperial Sugar, 25c.; 1 pkt. Early Wyman Cabbage, 25c.; ½ oz. of Marblehead Mammoth, 50c.; ½ oz. of Improved American Savoy, 25c.; ¼ oz. of Improved Brunswick, 25c.; ½ oz. of Premium Flat Dutch, 20c.; ½ oz. of Improved Red Dutch, for pickling, 25c.; ¼ lb. Carrot, Bliss's Improved Long Orange, 50c.; 1 pkt. Cauliflower, either the Early White Erfurt, or the Early Paris, 25c.; ½ oz. Celery, Boston Market, 25c.; 1 oz. Cucumber, finest for pickling, 25c.; 1 pkt. New Black Pekin Egg-Plant, 25c.; 1 pkt. Kale, New Garnishing, 25c.; ½ oz. Lettuce, Early Simpson, 25c.; 1 pkt. Muskmelon, either the Hackensack, or Sill's Hybrid, 15c.; 1 pkt. Onion, either the New Queen, or New Giant Rocca, 15c.; 1 pint Peas, Laxton's Alpha, 25c.; 1 pint Peas, McLean's Little Gem 30c.; 2 oz. True Boston Marrow Squash, 50c.; 2 oz. of Turban do., 50c.; 2 oz. of Genuine Hubbard do., 50c.; ½ oz. of Marblehead do., 25c.; 2 oz. Tobacco, Conn. Seed Leaf, 50c.; 1 oz. Arlington Tomato, 50c.; 1 pkt. Grapeshot do., 15c.; 1 Lilium auratum, or New Gold-banded Lily, from Japan, 50c.; 1 Lilium lancifolium rubrum, Japan Lily, red, 40c.; 1 Lilium lancifolium album, Japan Lily, white, 40c.; 1 doz. Gladioluses, fine mixed varieties, \$1.50; 1 doz. Mexican Tiger Flowers, \$1.25; 1 doz. Tuberoses, Double Italian, best, \$1.50; 1 doz. Hyacinths, double and single, in three colors, red, blue, and white (for fall planting), \$1.50; 4 doz. Tulips, double and single, early and late (for fall planting), \$2.00; 100 Crocuses, fine varieties (for fall), \$1.00.

No. 44. — Automatic Family Knitting Machine.—Here is a Premium which many families will be glad to obtain. These Knitting Machines are very easily managed, not liable to get out of order; they can be attached to an ordinary table and worked by a child. They are adapted to the production of a great variety of work, both of plain homespun for wearing apparel and elaborate crochet stitching of the most varied character, limited only by the skill and taste of the operator. Indeed, the ingenuity and taste of ladies may be constantly stimulated by inventing and successfully producing new forms and styles, making it a source of pleasure as well as of profit. The following articles may readily be knit on these machines, in any design, form, color, or stitch: *Socks, Stockings, Mittens, Leggings, Wristslets, Gloves, Scarfs, Sashes, Capes, Drawers, Undershirts, Skirts, Ties, Trimmings, Tuffings, Toilet Mats*, etc., etc. The machine offered is the No. 1 style, price \$35. For 62 subscribers at \$1.50 each, or 192 at \$1 each, we will give one of the No. 3 style, price \$45. Manufactured by the **New York Knitting Machine**

Co., 689 Broadway, New York, who will supply descriptive circulars upon application to them.

No. 45. — Secor Sewing Machine.—“A good Sewing Machine lightens the labor and promotes the health and happiness of those at home.” We offer one of the best of the leading machines, and it is one which has been thoroughly tested and gives entire satisfaction. While all of the high-cost machines are valuable, each has some excellence peculiar to itself. The **Secor** machine is claimed to be as absolutely near perfect as human genius has yet devised, and to comprise the *fewest number of pieces* of any lock-stitch machine. Its tension is very simple, and no change is required in passing over seams. It will sew *from tissue paper to leather*. The tension-plates are close to the needle, and if the thread is cut from the spool, will work until the thread is exhausted. The needle is *self-setting*, short and straight, and as it can only be put in one way, can not be set wrong. All the works being above the table, they are easily oiled and cleaned.—These machines have constantly increasing sales, showing the public estimate of their value. One of them will prove a great treasure in any household—worth more than \$500. The \$500, at 7 per cent interest, would yield (less taxes) about \$32. Most families require at least four months of steady hand-sewing a year, costing, if all hired, not less than \$24 a month, board included, or \$96 a year. With a Sewing Machine, a woman can sew more in one month than in four months by hand. Here is a clear saving of \$72. But far above this—the everlasting “Stitch, stitch, stitch,” the bending over the work, and the loss of sleep, have brought tens of thousands to early graves. We say to *every man*, Get your wife a Sewing Machine, even if you have to sell a favorite horse or an acre or two of land—get the Sewing Machine any way. If you can get one through our premium-list—well; but get the machine.—No charge for boxing the machines. They go safely as freight. Send for circulars, giving full instructions, to **Secor Sewing Machine Co.**, 900 Broadway, N. Y.

No. 46. — Beckwith Portable Family Sewing Machine.—This Machine is well and strongly made, is simple, its use being quickly learned, is applicable to almost all kinds of family sewing, and has already been tested so thoroughly that hundreds of testimonials, from all quarters, have been given by the who are delighted with its work. The new Portable Machine, price \$20, which we now offer, comprises all the excellencies of the lower priced machine first sold by the Beckwith Co., with many valuable improvements. Its size and power are increased, and its capacity thus very much enlarged, without impairing its portability. There have been added cam and eccentric movement, a balance-wheel, and also an oscillating needle-clamp, by which the length of stitch can with the greatest ease be changed to the finest shade of variation without touching the needle. Each machine is put in a neat, compact box, with *hemmer and guide, oil-can with oil, thread, different-sized needles, etc.*, with full printed directions for using. We will sell these machines (packed in a neat, portable case, with handle to carry it easily) to any one who may wish to buy, for \$20 each, delivering to any express office in *this city*, or give them as in Premium List.

No. 47. — Doty's Improved Clothes Washer, with the Metropolitan Balance Weight. Over seventy-five thousand families in the United States are using the Doty Washing Machine, and we believe the improved machine has no superior. The “help” use it and like it. Send for descriptive circulars to **R. C. Browning**, 32 Cortlandt St., New York, or to **Metropolitan Washing Machine Co.**, Middlefield, Ct. It goes cheaply by freight or Express.

No. 48. — Universal Clothes Wringing Machine.—A very useful, time-saving, strength-saving, clothes-saving implement, that should be in *every family*. The wringing of clothes by hand is hard upon the hands, arms, and chest, and the twisting stretches and breaks the fibers with lever power. With the Wringing Machine, the garments are passed rapidly between elastic rollers, which press the water out better than hand wringing, and as fast as one can pick up the articles. We have given thousands of these premiums, with almost universal satisfaction. They are made by the **Metropolitan Washing Machine Co.**, Middlefield, Ct. **R. C. Browning**, 32 Cortlandt St., New York.

No. 49. — Melodeons.—These are excellent and desirable instruments, for the *Home Circle*, for small Churches, for Sunday-schools, for Day Schools, Academies, etc. Instrumental and Vocal Music in a school has a beneficial influence upon the pupils. We have seen the whole tone and character of a school improved by introducing a Melodeon.—Set the pupils to work and they will raise a club of subscribers for this premium. We offer the Melodeons made by **Messrs. Geo. A. Prince & Co.**, Buffalo, N. Y., for we know them to be good.—Several clergymen have obtained this premium for themselves, their Churches, or Sunday-school rooms. The clubs of subscribers were quickly raised among the members of their parishes.—Many others can get a

Melodeon for their *home use*. Send a postage-stamp to the makers and get their illustrated descriptive circular. These Melodeons will be shipped direct from the manufactory at Buffalo. They can go safely as freight or by express. If an Organ should be wanted instead of a Melodeon, we can supply it for an increased number of subscribers in proportion to the value.

No. 50. — Steinway Piano.—SEVEN OCTAVE ROSEWOOD CASE, SOLID ROSEWOOD DESK, LARGE FRONT, ROUND CORNERS; OVERSTRUNG BASE, FULL IRON FRAME, PATENT AGRAPPE TREBLE, CARVED LEGS, AND CARVED LYRE.—This is one of the most elegant Premiums ever offered; regular and only price \$650. That this magnificent instrument comes from the celebrated establishment of **Messrs. Steinway & Sons**, Nos. 109 & 111 East 14th St., N. Y., is enough to say; but it is due to these enterprising manufacturers to state that while their pianos have repeatedly received the **FIRST PREMIUMS**, by the award of the most competent judges the world can produce, at the Universal Exposition, in Paris they received the **FIRST GRAND GOLD MEDAL**. The following official certificate was signed by the President and the five members of the International Jury: “Paris, July 20th, 1867. I certify that the First Gold Medal for American Pianos has been unanimously awarded to Messrs. Steinway by the Jury of the International Exhibition. First on the List in Class X.” The Jury on Musical Instruments at the World's Fair, 1873, (where Steinway & Sons did not exhibit their pianos), passed the following unanimous resolution: “It is much to be deplored that the celebrated inaugurators of the new system in Piano-making, Messrs. Steinway & Sons, of New York, to whom the entire art of Piano-making is so greatly indebted, have not exhibited.” The world renowned Artists and Composers, Dr. Franz Liszt and Anton Rubinstein, use the Steinway pianos exclusively, and pronounce them the standard pianos of the world. Many of the best judges in America say the same. We also speak from personal knowledge, as two of our officers have for years each had one at home. This splendid premium may be secured by many persons. *Many Ladies* have secured this premium, and some have obtained two or more, and sold the extra ones, thus securing large salaries. Classes of young ladies at school can unite in canvassing, and obtain a present for a Teacher, or a Piano for their school-room. We shall be glad to give this premium to a large number. Send to **Messrs. Steinway & Sons, N. Y. City**, for a free circular describing it.

No. 51. — A Good Watch.—The Watches made by the **American Watch Co., Waltham, Mass.**, have peculiarities of excellence which place them above all foreign rivalry. The substitution of machinery for hand labor has been followed not only by greater simplicity, but by a precision in detail, and accuracy and uniformity in their time-keeping qualities, which by the old method of manufacture are unattainable. A smoothness and certainty of movement are secured which proceed from the perfect adaptation of every piece to its place. The extent of the Waltham establishment, the combination of skilled labor with machinery perfect and ample, enable them to offer watches at the lowest rates. Their annual manufacture is said to be double that of all other makers in this country combined, and much larger than the entire manufacture of England. The mechanical improvements and valuable inventions of the last fifteen years, whether home or foreign in their origin, have been brought to their aid, and the presence of nearly 800,000 Waltham Watches in the pockets of the people is the best proof of the public approval. We offer a Silver watch, jeweled, with chronometer balance, warranted by this Company as made of the best materials in the best manner, and in pure coin-silver “hunting” case; weight 3 oz. This watch we offer as one of our Premiums, with the fullest confidence. Upon the movement of each of these watches will be engraved, “**AMERICAN AGRICULTURIST. MADE BY THE AMERICAN WATCH CO., WALTHAM, MASS.**”

No. 52. — Breech-loading Pocket Rifle.—This remarkable little fire-arm weighs only eleven ounces, yet shoots with great accuracy and power from 30 to 100 yards, or more, and can be loaded and fired five times a minute. It can be carried in a side pocket, and is accompanied by an extension breech, so that it may be used either as a pistol or rifle. It is put up in a neat mahogany case, with 250 rounds of ammunition. The manufacturers are **Messrs. J. Stevens & Co.**, Chicopee Falls, Mass., and the rifles are sold at retail by **Mr. Edwin S. Harris**, No. 177 Broadway. Without the mahogany case, we will give the weapon, all complete, with 100 cartridges, packed in a pasteboard box, on receipt of 18 subscribers, at \$1.50 each.

No. 53. — Double-Barrel Gun; OR FOWLING PIECE.—These guns are the genuine London “Twist” barrel, Patent Breech, Bar Lock, ebony ramrod, and in all respects desirable. Their caliber and length of barrel vary, and may be ordered to suit the kind of shooting to be done. They are furnished for this Premium by **Mr. Edwin S. Harris**, 177 Broad-

way, well known as one of the most reliable and best dealers in his line of business, and he highly recommends this particular gun, and guarantees it in every respect. It is from one of the oldest and most favorably known English manufacturers. The price is not put on in fancy carving and plating for show, but in the gun itself. This Premium includes the Gun, Powder-Flask, Shot-Pouch, and Wad-Cutter.

No. 54.—Chas. Pratt & Co's Astral Oil supplies a great Public Want for a *Safe, Reliable Illuminating Oil*. It is manufactured by them and packed only in the Guarantee Patent Cans, expressly for FAMILY USE. It has more body, and an equal quantity will burn longer and give more light than other oils. The constant recurrence of explosions, fires, devastation, and death resulting from the use of what is called Kerosene Oil—but really a mixture of Benzine, Naphtha, and other highly inflammable substances, the use or sale of which is an infringement of United States Law—has induced us to place this article on our premium-list as a humanitarian as well as a useful act. The Board of Health of the city of New York have examined scores of samples of Oil obtained from as many different dealers in this city, and nearly all have been found far below the Government standard and entirely unfit for use. This "Astral Oil" is from the House of **Chas. Pratt & Co.**, 108 Fulton St., N. Y., merchants of high reputation, who will keep up the article to its present standard. It has been tested, and fully indorsed by the highest scientific authorities in the land. The Guarantee Cans are made of tin, and sealed so that none of the oil can be removed without breaking the seal, thus securing safety in transportation. The can is inclosed in a strong wooden case, and may be returned for refilling cheaply. For 17 subscribers at \$1.50, we will send a case containing 12 one-gallon Guarantee Cans of Oil, which may be distributed among a club.

No. 55.—Cahoon's Broadcast Seed-Sower.—The Hand Seed-Sower is the one offered as our Premium. It sows from four to eight acres per hour, at a common walking gait, throwing wheat and rye from 30 to 36 feet wide; barley, 30 feet; hemp, 28 feet; oats, 23 feet; clover, Millet and Hungarian seed, 22 feet; and Timothy, 18 feet. Manufactured by **D. H. Goodell**, Antrim, N. H.

No. 56.—Comstock's Horticultural Implements Combined or Separate.—These hand implements comprise, in simple combinations, a *Wheel Seed Sower, Wheel Cultivator and Onion Weeder, Wheel Rake, Wheel Scuffle Hoe, Wheel Shovel Plow, Wheel Strawberry Runner Cutter, Wheel Mole Plow, and Wheel Verge or Turf Cutter.*—The changes for each kind of work can be made in a few minutes, and every implement of the combined machine works as well as if made specially for the purpose. The same frame, wheel, and handles answer for all the combinations. The price of the Hand Cultivator and Weeder is \$9.25 (see our Premium in the Table); with Seed-Sower combined \$15.35, which we will give for 23 subscribers at \$1.50 or 78 at \$1. The following are extra attachments for the Cultivator and Weeder, which may be secured by sending us, in addition to the above, the same number of subscriptions required for any other Premium of same cost: *Strawberry Cutter, \$3.00; pair of Half-share Teeth, \$1.00; set of Shovel Plows, \$2.00; Mole Plow, \$1.00; a Verge-Cutter for cutting and cleaning the turf edges of walks and borders, an exceedingly valuable invention, \$1.50; Scuffle Hoe, for scraping walks and alleys, \$1.50.* They have given so much satisfaction the five years we have furnished them as Premiums that we continue them on our Premium List. Manufactured by **Comstock Brothers**, East Hartford, Ct., who furnish descriptive circulars to all applicants.

No. 57.—Family Scales.—These scales, combining the advantages of counter and platform scales, are peculiarly adapted to household purposes. They weigh from ½ ounce to 240 lbs. They have a scoop, or pan, for weighing flour, sugar, or other house stores, and a platform for heavier articles, and are just such an apparatus as is needed for in-door or out-door use, occupying less than 2 feet square. These scales are manufactured by the well-known **Fairbanks & Co.**, No. 311 Broadway, New York, whose weighing apparatus has long ranked as the standard in all parts of the country. Send to them for circulars, if desired.

No. 58.—The Great Dictionary.—WORCESTER'S LARGE PICTORIAL UNABRIDGED EDITION, containing 1854 three-column pages, with a multitude of illustrative engravings. (The work is a large quarto volume.) Most of the thoroughly educated men of the country consider this as by far the best Dictionary in the English Language. It gives the spelling and pronunciation of every word in the language with full explanations, and as a source of general information stands next to a Cyclopaedia. The Dictionary can be called for at our office, or be sent by express or otherwise to any part of the country. It should be in every family. It is published by **Brewer & Tileston**, Boston.

Nos. 59 to 67.—Volumes of the American Agriculturist (Unbound).—These amount to a *large and valuable Library* on all matters pertaining to the Farm, Garden, and Household, and contain more varied information on these subjects than can be obtained in books costing three times as much. The price of the volumes is \$1.50 each, at the Office, or \$1.75 if sent by mail, as they must be post-paid.—They are profusely illustrated, the engravings used in them having alone cost at least \$100,000. Those obtaining premiums for less than eighteen volumes can select any volumes desired, from XVI to XXXIII inclusive. For ordinary use, the sets of numbers unbound will answer.

Nos. 68 to 77.—Bound Volumes of the Agriculturist.—These are the same as Nos. 59 to 67 above, but are neatly bound in uniform style, and cost us more for binding and postage. Sent post-paid.

Nos. 78 to 89.—Good Libraries.—In these premiums, we offer a choice of **Books** for the **Farm, Garden, and Household.** The person entitled to any one of the premiums 78 to 89 may select any books desired from the list of our books published monthly in the *American Agriculturist*, to the amount of the premiums, and the books will be forwarded, *paid* by Post or Express. Let the farmers of a neighborhood unite their efforts, and through these premiums get an agricultural library for general use. See Table List of Books in advertising columns, or send for Catalogue.

No. 90.—General Book Premium.—Any one sending 25 or more names, may select books from our list to the amount of 10 cents for each subscriber sent at \$1; or 30 cents for each name sent at \$1.20; or 60 cents for each name at \$1.50. *This offer is only for clubs of 25 or more. The books will be sent by mail or express, prepaid through, by us.* See List as in No. 89.

Now
IS THE TIME TO MAKE AND TO
Save Money.
— READ HERE
How To Do It.

The Publishers of this Journal have received verbal and written testimonials from thousands of subscribers, in substance as follows:

"I have taken the *American Agriculturist* for many years. It has paid for itself a hundred times in the information it has given me."

"Your paper, with its beautiful pictures and valuable articles, is always a welcome visitor to our household."

"My son says that what he has learned about farming from the *Agriculturist*, will make him a better farmer than his father. I wish I could have seen it when I first began farming."

"Our young folks are always in a hurry to get at the 'Boys' and Girls' Columns.' Who is 'The Doctor?'"

"My wife says no farmer's wife ought to be without the *American Agriculturist*. She values highly the Household Department."

"The *Agriculturist* was taken by my good father for twelve years, and I shall never fail to have it, so long as I can raise \$1.50 a year for such a paper."

"I made more than five hundred dollars from practicing upon the hints in one single article in the *American Agriculturist*."

"How can you possibly afford so valuable a paper at so small a price?"

Now, WHAT is the
American
Agriculturist?

It is a beautifully illustrated Journal, established in 1842, for the **Farm, Garden, and Household**, including a special in-

teresting and instructive Department for **Children and Youth.**

It is a large periodical of 44 pages, well printed, and filled with *plain, practical, reliable original matter*, including hundreds of **beautiful Engravings** in every annual volume.

It contains each month a Calendar of Operations to be performed on the **Farm, in the Orchard, Garden, and Dwelling**, etc.

It comprises thousands of hints and suggestions, in every volume, prepared by practical, intelligent, **working men**, who know what they write about.

It has a **Household Department**, valuable to every Housekeeper, affording very many useful hints and directions calculated to lighten and facilitate in-door work.

It has a **Department for Children and Youth**, prepared with special care, to furnish not only amusement, but also to inculcate knowledge and sound moral principles.

When the large expense involved in providing its interesting and varied reading matter, and its great number of superb illustrations, is considered, it is the

Cheapest Paper in the World.

Its subscription price is only **\$1.50 a year**; four copies for \$5; ten copies for \$12; twenty, or more, \$1 each; to which ten cents must be added and sent with *each subscription*, whether singly in clubs, to pre-pay postage for the year 1875, which must be done here, by the Publishers.

BETTER YET.

To every Subscriber for 1875, (received in October,) that is, for the whole of Vol. 34, the Publishers will present an exquisite Chromo, *as detailed below*, and in addition to this, each subscriber, whose subscription is received during October, will get the remaining two numbers of the current year, *i. e.*, November and December, **without extra charge.**

As long as any of both Chromos are in stock, a choice will be given to new subscribers of either one of the two beautiful pictures

"Up for Repairs,"
"Mischief Brewing,"

but the choice must be named at the time of subscribing.

The chromo selected will be delivered at 245 Broadway *free of charge*. If to go by mail, 10 cents extra must be sent to cover cost of packing and postage. **For 25 cents it will be Mounted, Varnished, Packed, and sent Post-paid.**

N. B.—The Chromo will be delivered:

At the office, **Unmounted, Free.**

" " " **Mounted, 15 cents extra.**

Sent by Mail, **Unmounted, 10 cents extra.**

" " " **Mounted, 25 cents extra.**

NOW SAVE MONEY.

Read the Premium List on the previous pages, get your friends to join you, and

➔ **SUBSCRIBE TO-DAY.**

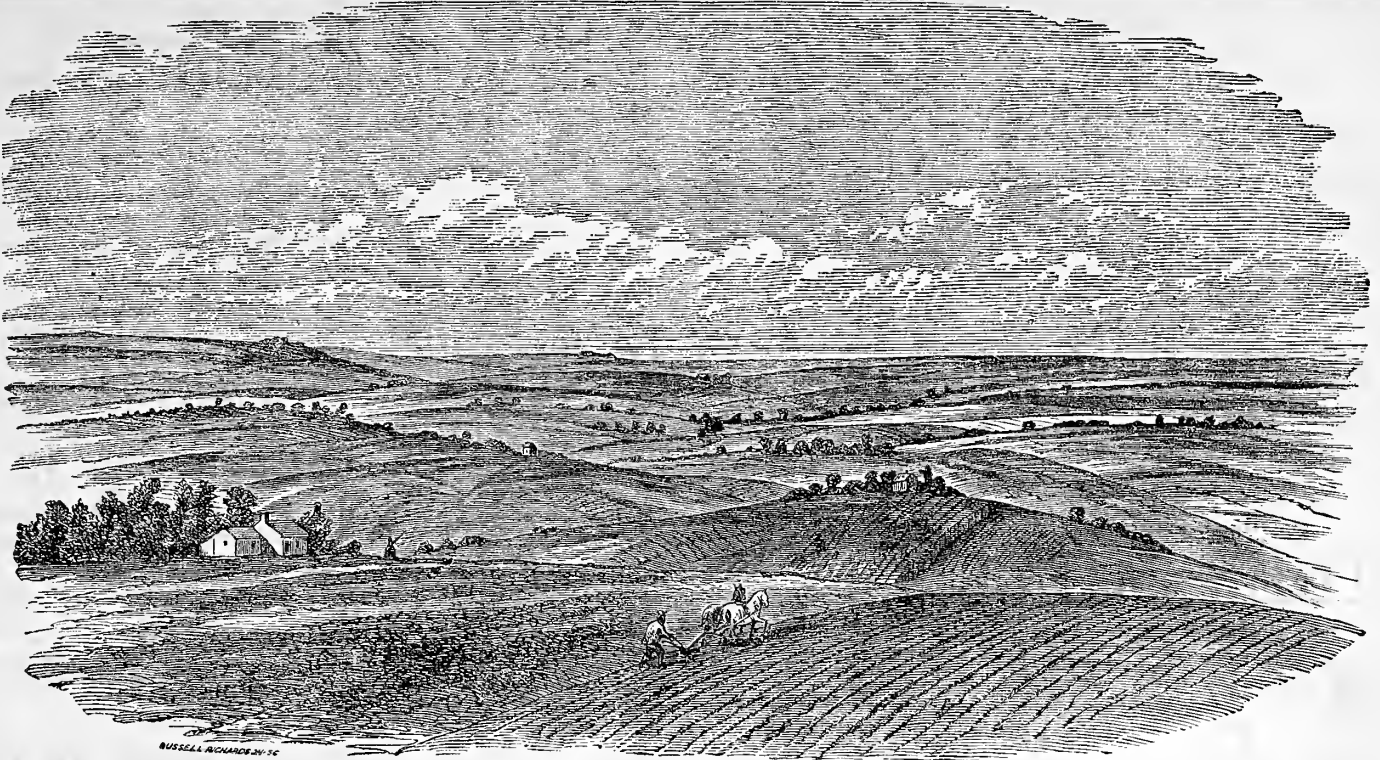

PRAIRIE, TEN MILES EAST FROM LINCOLN, NEB.

8

IF YOU WANT A FARM OR HOME,

YOU SHOULD BUY OF THE

BURLINGTON AND MISSOURI RIVER RAILROAD CO.

IN IOWA OR NEBRASKA.

- BECAUSE**—Their prices are low, ranging for the best land from Three to Ten Dollars per acre.
- BECAUSE**—No payments are required of the purchaser for four years, except interest at six per cent.
- BECAUSE**—After the fourth year only one seventh of the principal is payable annually till the whole is paid.
- BECAUSE**—You are not required to go into a wilderness, these being well-settled States, the population of which is rapidly increasing.
- BECAUSE**—The mildness of the climate and fertility of the soil is such that the settler can pay for his farm from the products raised upon it long before the time when the principal becomes due.
- BECAUSE**—Failure of crops from drouth is unknown.
- BECAUSE**—Large allowances are made upon fare and freight, thus giving low rates on both to purchasers of this Company's lands.

AND YOU SHOULD BUY THIS YEAR.

BECAUSE—Purchasers of our lands in Nebraska during 1874 who cultivate one-half their land within two years from their purchase are allowed a reduction of twenty per cent on its price. **LARGE DISCOUNTS** also, FOR CASH, within One, Two, or Five Years.

Send for Circulars, with full information on all points, to

GEO. S. HARRIS, Land Commissioner,

At Lincoln, Nebraska, for land in Nebraska. At Burlington, Iowa, for land in Iowa.

Or to **W. D. COWLES**, General Agent, 317 Broadway, New York.

JAS. R. WOOD, General Agent, 59 Clark St., Chicago, Ill.

Established 1858.

TRADE MARK PATENTED.

The best and cheapest Paint in the world for Iron, Tin or Wood. For sale by the Trade everywhere. **PRINCE'S METALLIC PAINT CO.**, Manufacturers, 96 Cedar St., New York.

CAUTION.—Purchasers and consumers are cautioned against imitations of our METALLIC PAINT. All genuine **PRINCE'S METALLIC PAINT** will bear our name and trade mark on each and every package. Send for a circular.

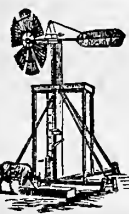

Halladay's Improved Wind-Mill.

PERFECTLY Self-Regulating. The Best, Cheapest, most Durable and Popular Mill made. Manufactured under the immediate supervision of Inventor 18 years. Two million dollars' worth now in use. Send for Catalogue.

U. S. WIND ENGINE & PUMP CO.,
BATAVIA, ILL.

PHILADELPHIA, June 11, 1874.
N. GUILBERT, Gwynedd, Pa.—Enclosed is sample of wool of a yearling ewe, bred from the ewe Cotswold that I ordered from you for Mr. Keller, at Akron, Pa.; the wool of the yearling weighed 15 1/2 lbs., and speaks very well for your stock. He intends having it advertised in the Lancaster newspapers. He sold all his other sheep, Yours, etc., A. R. FRASER, No. 415 S. Second St. Always on hand and for sale, Cotswold Sheep, Southdowns, Blooded Live Stock, Horses, Cows, Calves, Swine, Geese, Ducks, Turkeys, Fancy Fowls, Peacocks, Dogs, Maltese Cats, Rabbits, Guinea Pigs, White Mice, Deer, Swan, Pigeons, etc. A noble pair of thoroughbred Mastiffs, and an elegant English Greyhound Dog. Wanted—Deer, Swan, and Wild Geese. N. GUILBERT, Evergreen Farm, Gwynedd, Pa.

Samples from B. E. Hale & Co., 56 and 58 Park Place, N. Y. Sole Agents for Eastern States.

BUILDING PAPER!

FOR SHEATHING, ROOFING, DEAFENING, CARPET LINING AND PLASTERING.

Samples from Rock River Paper Company, Chicago, Ill.

EVERY LADY SHOULD HAVE A SET OF GOODRICH'S "SPRING" HEMMERS

Consisting of Four Widths and a Dress Binder. Sent by Mail on Receipt of Price.

For Sale by all Sewing Machine Agents. } **H. C. GOODRICH**, {205 State Street, CHICAGO, ILL. }
Price, Only One Dollar. } {103 N. 10th St., PHILADELPHIA, PA. }

Inventor of The Goodrich Tuck Marker.

P-E-T-R-O-L-E-U-M. CRUDE AND REFINED.

CRUDE PETROLEUM is unexcelled as a wash to preserve Fences, Shingle Roofs, Agricultural Implements, and wood of any kind, from decay, and Metal from rusting.

REFINED PETROLEUM for light is safe, pure, of standard legal test, and cheap.

Save two or three commissions by ordering one barrel or fifty direct from the Oil Regions of Pennsylvania. Address a reader of the *Agriculturist*, **GEO. M. LYONS**, Titusville, Pa.

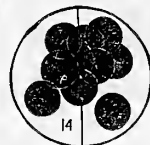

MAYNARD'S BREECH-LOADING Combination Rifles and Shot-Guns.

CENTRAL FIRE Reloading-Capped Cartridges. Send for Price-list with Target Illustrations.

Mass. Arms Co., Chicopee Falls.

ADVERTISERS should send to **GEO. P. ROWELL & Co.**, 41 Park Row, N. Y., for their *Eighty-page Pamphlet*, containing lists of 3,000 newspapers and estimates, showing the cost of advertising. Mailed free to all applicants.



Improved Foot Lathes.

Small Engine Lathes, Small Gear Cutters, Hand Planers for Metal, Ball Turning Machines, Slide Rests, Foot Scroll Saws. The very best. Selling everywhere. Catalogues free.

N. H. BALDWIN, Laconia, N. H.

Just the articles for Artisans or Amateurs.

Lovejoy's New Style GLASS CUTTER

And Putty Knife Cuts glass better than a diamond. Everybody should have one. Any child can use it. Sent to your address on receipt of 50c, and stamp by

ALVAN L. LOVEJOY,
229 Washington St., Boston, - - - Mass.
Liberal Discount to Wholesale and Retail Dealers.

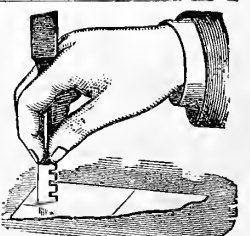

\$290 Piano. Circulars free. U. S. Piano Co. - 810 B'dway, N. Y.

THE MITCHELL WAGON.

THE
Best Proportioned,
Best Ironed,
AND
Lightest Running
Wagon in the Market.
The original, well known
RACINE WAGON.

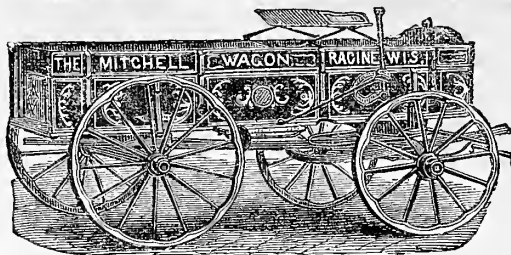

In use and for sale in
nearly every
STATE & TERRITORY
IN THE UNION.
All work fully warranted.
SEND FOR PRICE LIST.
Mitchell, Lewis
& Co.,
RACINE, WIS.

THE FARMER'S Favorite Cider Mill.

Buy no Cider Mill until you have examined the **Farm-er's Favorite**.
It is the best built, cheapest, and most durable Mill in market.
It will produce 25 per cent more juice from the same amount of cheese, than any other mill manufactured.
Send for Descriptive Circular.
HIGGANUM MANUFACTURING COMPANY,
Higganum, Conn.

CIDER MILLS.

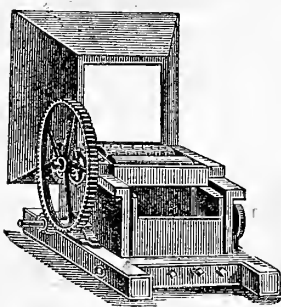

The most perfect
Cider Apple Grinder
in use, in grinding fast
and fine, and giving
the best satisfaction.

Price, \$40.

I have also the eas-
est, handiest, quickest
working, and most
powerful Press in use.
Send for Descrip-
tive Circulars.

Address **MARCUS P. SCHENCK,**
Fulton, N. Y.

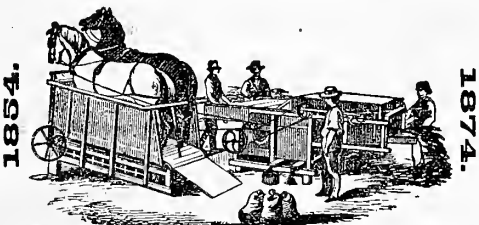

The Peerless Thresher and Cleaner—Peerless
Thresher and Patent Shaker.
The Peerless Straw Preserving Rye Thresher.
The Peerless Clover Huller and Cleaner.
Horse, Tread and Lever Powers—all sizes.
The best material used, and by first-class mechanics.
B. GILL & SON,
Trenton Agricultural Works, Trenton, N. J.

HALL'S PATENT HUSKING GLOVES.

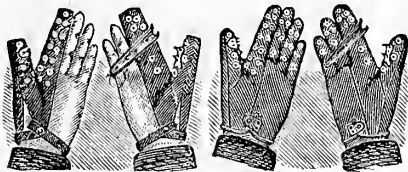

VERY GREATLY improved in form of the claws and
the more complete shielding of the parts subject to wear.
(See cuts.) making them wear *five times as long*, and doing
the work much faster and easier, than can be done with any
other husker. Made of the *very best* calf leather, (tanned
expressly,) in four sizes; right and left handed. Samples
sent pre-paid on receipt of price. Half Gloves, \$1.25; Full
Gloves, \$2.50 per pair. We also manufacture *extra quality*
plain calf working Gloves and Mittens. Price, pre-paid,
Mittens, \$1.10; Gloves, \$1.75 per pair. Liberal discount on
all our goods in quantities. Ask your merchant, or address
HALL HUSKING GLOVE CO.
145 So. Clinton-st., Chicago, Ill.

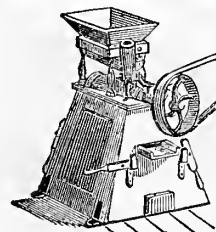

PREMIUM FARM GRIST MILL.

Is simple, cheap and durable,
and grinds all kinds of grain
rapidly. It is adapted to all
kinds of horse powers.
Also Union Railway Horse
Powers, requiring a very low
elevation and yet giving more
power than others. Also every
variety of approved Imple-
ments. SEND FOR DESCRIPTIVE
CIRCULAR.
WM. L. BOYER & BRO.,
Philadelphia, Pa.

CADY'S PATENT IRON SLEIGH KNEES

Have been tested thoroughly the past five years, and are in
use in almost every Northern State; we have yet to hear of
the first instance wherein they have failed to give entire
satisfaction. We can not express the approval with which
these Knees are received by the public, better than to refer
you to the following, which express the sentiments of hun-
dreds of letters in our possession.

ARE CHEAPER, MORE DURABLE,
NO JOINTS TO DECAY.

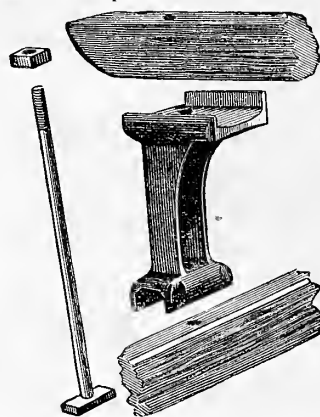

WILL CARRY DOUBLE THE
LOAD OF A WOODEN KNEE.

"The Sleighs I built with your Knees are the cheapest and
most durable I ever built. When they are put together,
they are half ironed. A man with half a head and but few
tools can build his own Sleighs."
H. W. HUBBARD, East Springport, Michigan.

"We have used your Knees in the manufacture of our
sleighs for the past 3 years, and have found them to be a
decided success in every particular."
SAUNDEISS & BARETT, Oneida, N. Y.

"Your Iron Sleigh Knees are an excellent thing. We have
used them on our rough roads with very heavy loads, and
they have stood the test. They are a Godsend to Farmers
living away from opportunities, and compelled to build their
own sleighs."
F. G. FINCKE, Bellasylva, Pa.

"I warrant my Bob-sleighs made with your Knees to carry
any Saw-log, or a load that a Team of Horses can draw."
ALANSON SHERMAN,
Palmyra, N. Y., Carriage Manufactory. Established 1828.

See illustration and description in *American Agriculturist*
for January, 1874, page 16.
WARRANTED AS REPRESENTED.
Send for Descriptive Circular and Price-List.
BRADLEY MANUFACTURING CO.,
Syracuse, N. Y.

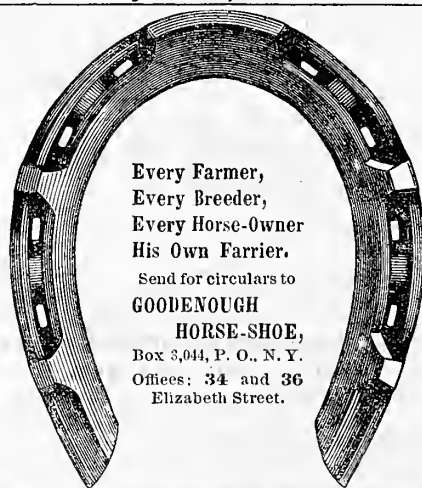

Every Farmer,
Every Breeder,
Every Horse-Owner
His Own Farrier.

Send for circulars to
**GOODENOUGH
HORSE-SHOE,**
Box 3,044, P. O., N. Y.
Offices: 34 and 36
Elizabeth Street.

BUCKEYE DRIER BAKER AND FEED STEAMER

For full particulars, address
ENGLE, KELLER & CO., Lancaster, Pa.

POMONA NURSERY.—Trees and
Plants, 100 Acres. Small Fruits.—For Illustrated
Catalogue, 32 pages, telling What and How to Plant, with 36
years' experience, send 10 cents. Price List Free.
WM. PARRY, Cinnaminson, N. J.

THE Hartford Pump

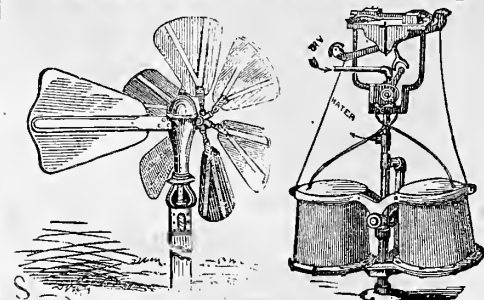

Water Driven to any Hight and Distance by
COMPRESSED AIR.

Country Houses supplied cheaply
and certainly for Bath Rooms, Wa-
ter Closets, Hot and Cold Water
Faucets, etc.
Plenty of fresh water for stock on
farms.

Address, **Hartford Pump Co.,**
41 Trumbull Street, HARTFORD, CT.
NEW YORK, Mason C. Weld, 189 & 191
Water Street. (P. O. Box 376.)
BOSTON, Ames Plow Co., Quincy Hall.

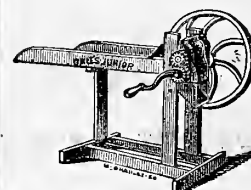

I have invented the cheap-
est and best hay, straw, and
stalk cutters in America.
\$9 size cuts 20 to 60 bushels
per hour. Set to cut any
length. I have also invent-
ed the cheapest and best
turnip cutter. Do not pay
until you have tried them
on your farm and like
them. Local Agents want-
ed. Splendid chance for
farmers. Circulars free.

WARREN GALE, Chicopee Falls, Mass.



Patent Concave Ox-Shoes.

The only forged ox-shoe made
with concavity to fit hoof, and the
best and cheapest.

GREENFIELD TOOL CO., Greenfield, Mass.

THE ILLUSTRATED Book of Poultry,

With Practical Schedules for Judg-
ing, Constructed from Actual
Analysis of the Best Mod-
ern Decisions.

By **LEWIS WRIGHT,**

Author of "The Practical Poultry Keeper," "The
Brahma Fowl," etc.

ILLUSTRATED WITH
Fifty Colored Portraits of Prize Birds,
Painted from Life by J. W. Ludlow.

CONTENTS.

- | | |
|---|--|
| CHAP.
1.—Houses and Accommo-
dation.
2.—The Selection of Stock.
3.—Feeding and General
Treatment of Poultry.
4.—Eggs and Incubation.
5.—Artificial Hatching.
6.—The Management of
Chickens.
7.—Fattening and Killing.
8.—Poultry as National
Food.
9.—The Utility of "Fancy
Points."
10.—Commencing a Strain.
11.—Mating Stock for Breed-
ing Prize Birds.
12.—Rearing, Care, and Exhi-
bition of Prize Poultry.
13.—Shows and Judging.
14.—Buying, Selling, and
Exporting.
15.—Enemies in the Yard.
16.—Diseases of Poultry.
17.—Technical Terms.
18.—Cochins. | CHAP.
19.—Brahmas.
20.—Malays.
21.—Game.
22.—Dorkings.
23.—Spanish.
24.—Hamburghs.
25.—Polish Fowls.
26.—French Breeds of Poul-
try.
27.—American Breeds of
Poultry.
28.—Unclassed Varieties of
Poultry.
29.—Bantams (Except Game).
30.—Game Bantams.
31.—Wild Breeds of Poultry,
Origin of the Domestic
Fowl.
32.—The Guinea Fowl.
33.—The Turkey.
34.—The Pea Fowl.
35.—Ducks.
36.—Geese.
37.—Swans.
38.—Possible Additions to
the Poultry Yard. |
|---|--|

Price, Postpaid - - - \$15 00
ORANGE JUDD COMPANY,
245 BROADWAY, NEW YORK.

BOOKS for FARMERS and OTHERS.

[Published and for sale by the Orange Judd Company, 245 Broadway, New York. Any of these books will be forwarded by mail, post-paid, on receipt of price.]

Table listing various books for farmers and others, including titles like 'Allen's (L. F.) American Cattle', 'Allen's (L. F.) Rural Architecture', and 'Allen's (R. L. and L. F.) New American Farm Book'.

Table listing books for stock-keepers, including titles like 'O. J. Co. keep in Stock the following Books: Architecture, By Cummings & Miller', 'Bicknell's Village Builder', and 'Bridgman's Young Gardener's Assistant'.

THE CULTIVATION OF THE WILLOW OR OSIER.

BY WILLIAM SCALING, Ten Years Basket Maker to Her Majesty and the Royal Family.

This little pamphlet, though written by an Englishman, and of course designed specially for cultivators among his countrymen, contains just those practical instructions for the planting and culture of the willow, which many among us will be glad to receive. It was designed to enable any one unacquainted with the cultivation of willows, for basket purposes, to grow them successfully.

Price, Post-paid, 25 Cents. ORANGE JUDD COMPANY, 245 BROADWAY, NEW YORK.

Newly Revised and Enlarged Edition. Practical Floriculture.

A Guide to the Successful Propagation and Cultivation of Florists' Plants.

By PETER HENDERSON, Author of "Gardening for Profit."

Beautifully Illustrated. Price, Post-paid, \$1.50.

In this work, which has everywhere become so deservedly popular, not only is the whole "art and mystery" of propagation explained, but the reader is taught how to plant and grow the plants after they have been propagated. The work is not one for florists and gardeners only, but the amateur's wants are constantly kept in mind, and we have a very complete treatise on the cultivation of flowers under glass, or in the open air, suited to those who grow flowers for pleasure as well as those who make them a matter of trade. The work is characterized by the same radical common sense that marked the author's "Gardening for Profit," and it holds a high place in the estimation of lovers of floriculture. The new edition has been thoroughly revised by the author, and much enlarged by the addition of valuable matter.

The following are a few of the subjects embraced in the latest edition:

- Laying out Flower Garden and Lawn; Designs for Grounds and for Greenhouses; Soils for Potting; Cold Frames; Hot-Beds; Greenhouses Attached to Dwellings; Modes of Heating; Propagation of Plants by Seeds and by Cuttings; Culture of the Rose and Tuberoses; Growing of Winter-flowering Plants; Construction of Bouquets, Baskets, etc.; Parlor and Window-Gardening; Wardian-Cases and Ferneries; Insects; What Flowers Grow in the Shade; Culture of Grape-Vines under Glass; The Profits of Floriculture; How to Become a Florist, etc., etc.

Window Gardening.

By HENRY T. WILLIAMS, EDITOR OF THE HORTICULTURIST, AND HORTICULTURAL EDITOR OF THE NEW YORK INDEPENDENT. FINELY ILLUSTRATED.

There can be no more attractive ornaments about the house than beautiful flowers, and Mr. Williams's book tells exactly how they may be arranged, and what flowers to plant. It is seldom that a book is published on such subjects containing so much practical information.

-The World (New York).

Table listing contents of 'Window Gardening' book, including chapters like 'Window Gardening - Its Pleasures - Increase in Popular Taste - Refining Influences', 'Location and Designs for Window Gardens', etc.

Price, post-paid, \$1.50. Either of the above books sent post-paid on receipt of price by

ORANGE JUDD COMPANY, 245 BROADWAY, NEW YORK.

FRAMES FOR THE CHROMOS.

We have made arrangements to supply frames to our subscribers who may desire them for the Chromos which we have distributed. Many will no doubt avail themselves of this opportunity to place these beautiful pictures in handsome frames at moderate cost. In all cases where sent by express, the purchaser will pay express charges. The prices of the frames are as follows:

For the Chromo, "UP FOR REPAIRS," Or for the Chromo, "LOOK OUT!"

Table listing prices for 'UP FOR REPAIRS' and 'LOOK OUT!' frames, including 'Letter A. Neat Black-Walnut Frame, Gilt Band... \$1.15'.

For the Chromo, "MISCHIEF BREWING."

Table listing prices for 'MISCHIEF BREWING' frames, including 'No. 1. Neat Black-Walnut Frame, Gilt Band... \$1.15'.

For the Chromo, "THE STRAWBERRY GIRL."

Table listing prices for 'THE STRAWBERRY GIRL' frames, including 'No. 8. Neat Black-Walnut Frame, Gilt Band... \$1.40'.

Address orders, specifying by its letter or number the frame desired, and inclosing price, as above, to the ORANGE JUDD COMPANY, 245 BROADWAY, NEW YORK.

GREAT DEDUCTION. TEAS and COFFEES

At Wholesale Prices.

Increased Facilities to Club Organizers.

Send for New Price-List.

THE GREAT AMERICAN TEA COMPANY,
(P. O. Box 5643.) 31 and 33 Vesey St., New York.

WOOD, TABER & MORSE, Eaton, Madison Co., N. Y.

MANUFACTURERS OF

Steam-Engines,

Portable, Stationary, and
Agricultural.

Hundreds in use in Shops, Printing Rooms, Mills, Mines, and on Farms and Plantations for Grain Threshing, Food Cooking for Stock, Cotton Ginning, Sawing, etc. Circulars sent on application.

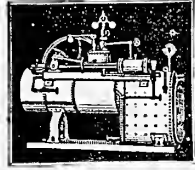

BOGARDUS' PATENT UNIVERSAL ECCENTRIC MILLS,

For Grinding Bones, Ores, Fire Clay, Guanos, Oil-Cake, Feed, Corn, Corn and Cob, Tobacco, Roots, Salts, Spices, Flax-Seed, Tomatoes, &c., and whatever can not be ground by other Mills. Also, for Paints, Inks, Blacking, &c.

JOHN W. THOMSON, Successor to James Bogardus,
Corner of White and Elm Streets, New York.

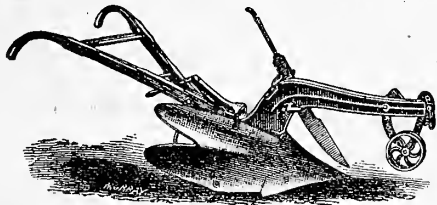

AVOID DEAD FURROWS.

For either Side-Hill or Level-Land work this plow has no equal, having, during its four years' existence, always won the first premiums in competition with the best **FLAT LAND**, as well as with other Swivel Plows. See June number, page 212, of *Agriculturist* for editorial comments, and for particulars address

CARR & HOBSON, 56 Beekman St., New York.

LAMB'S KNITTING MACHINE

IS the only Machine that can knit all sizes of work, and narrow and widen it; that can shape and complete, without hand finishing, seamless Hosiery, Gloves, and Mittens, or knit them in all sizes; or Knit Ribbed, Double, and Fancy stitches for Underwear, Jackets, Shawls, Scarfs, etc. It knits over 25 different Garments. Over 100 per cent Profit in Manufacturing Knit Goods. The Farmer trebles the value of his Wool by converting it into Knit Goods. Women make \$5.00 a day with it. Agents wanted. Send stamp for Samples of work, and reduced Price-List. Address, LAMB KNITTING MACHINE CO., at Chicopee Falls, Mass.; Cincinnati, O., or Chicago, Ill.

HARNESS, BLANKETS,



HORSE CLOTHING, and HORSE FURNISHING GOODS of every description, Style and grade at prices that please everybody.
ELEGANT NEW STYLES FOR THIS FALL AND WINTER.

C. M. MOSEMAN & BRO.,
Manufacturers, 114 Chambers St., N. Y.
Send for Illustrated Price-List.

GENUINE Peruvian Guano.

NEW YORK, SEPTEMBER 1ST, 1874.

I have the pleasure to inform the agricultural community, that the Special Agency established for the sale of Genuine Peruvian Guano, in small or large lots, at the same price at which it may be sold by Messrs. Hobson, Hurtado & Co., the sole Agents of the Peruvian Government in this country, has met with great success so far.

Verbal reports and numerous letters, received daily at this Agency, subject to the perusal of those interested, express entire satisfaction with the Guano sold by me last Spring. Farmers and country dealers are finding out that the Guano imported now, is as good as it was until adulterated by unscrupulous jobbers, in such a manner that many consumers were obliged to abandon its use. As, however, the knowledge of this Agency has spread, they are availing themselves of this opportunity to obtain again the genuine article.

By instructions of the Peruvian Government, their Agents here have advanced the price of Guanape Guano from this date to sixty-two dollars and fifty cents, (\$62.50) gold, per ton of 2240 lbs., gross, establishing at the same time a new scale of discounts, the lowest being of 50c. on parcels from 50 to 100 tons, and the highest \$4.00 on 500 tons and over. As usual, they will not sell in lots of less than ten tons.

Under this new arrangement I am enabled to fill orders for lots of ten tons and upwards, at less price than the Agents of the Peruvian Government. I will, as heretofore, supply quantities under ten tons at the same rate as charged by them.

Full particulars given in circular mailed free on application.

R. BALCAZAR,

P. O. Box 129. No. 53 Beaver Street, New York.

REFERENCES BY PERMISSION:

Messrs. HORTON, HURTADO & Co., Financial Agents of the

Peruvian Government, 52 Wall Street, New York.

MOSES TAYLOR, Pres. National City Bank, 52 Wall St., N. Y.

J. C. TRACY, Esq., Peruvian Consul, 26 1/2 Broadway, N. Y.

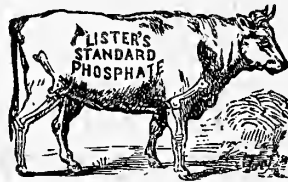

CELEBRATED FERTILIZERS.

Pure Bone Superphosphate of Lime.

GROUND BONE, BONE MEAL, BONE FLOUR.

The large annual increase of the sales of these Standard Fertilizers is the best proof of their merits. Their freedom from adulteration, with every particle available for fertilizing, and the low price at which they are sold make it for the interest of every practical farmer to give them a fair trial.

LISTER BROTHERS,

New York Office, 159 Front St. Factory, Newark, N. J.

Farmer and Dealers are invited to send for Circular.

PAINT

PURE WHITE LEAD, ZINC, and LINSEED OIL,

MIXED READY FOR USE.

White, Black, and all the other Shades, and sold by the gallon.

Send for Sample Cards and Price-List.

N. Y. Enamel Paint Co., 43 Chambers St., N. Y.

GRAPE-VINES.

We invite the attention of Planters and Dealers to our very large and superior stock of all the leading Varieties, and many new and rare sorts.

Price Lists for Fall 1874 gratis. Address

BUSH & SON & MEISSNER, Bushberg, Mo.



LOVEJOY'S METALLIC WEATHER HOUSES

Indicate the changes in the weather, and are pretty mantel ornaments. The little lady appears in fair and the man in stormy weather, and they never make mistakes. Sent prepaid to any address, safely packed, upon receipt of \$2 (Two), by **ALVAN L. LOVEJOY,** Proprietor and Manufacturer, 229 Washington St. Boston.

Special price to dealers.

F. G. MOELLER,
Landscape Gardener and Engineer
of Rural Improvements. Best of reference given. Address
F. G. MOELLER, 176 Broadway (Room 58), N. Y.

A M A G R I . **P A T . D E P T .**

IMPORTANT TO INVENTORS.
American Agriculturist
PATENT DEPARTMENT

In compliance with the request of numerous inventors, we have organized a

PATENT DEPARTMENT
in connection with this office for the transaction of all business connected with

Securing Patents
in the United States and foreign countries.
The character for

Reliability
which has been maintained by the AMERICAN AGRICULTURIST for more than thirty years will be carefully guarded in this as in other departments.

All Inventors
desirous of procuring patents at moderate cost are invited to forward (express prepaid) a model of their invention, with a brief description of its working. The model should not exceed one cubic foot in dimension. Upon receipt of model an opinion as to patentability will be given free of charge.

Preliminary Examination
at the Patent Office, to determine patentability, will be promptly made for a fee of \$5.

Litigation of Patents.
The services of the best counsel have been secured to prosecute or protect before the U. S. Courts and the Patent Office the claims of those intrusting their business to this agency.
Specifications, drawings, engravings, models, and all other appliances furnished at moderate prices.

In all dealings with this Department inventors may depend upon promptness, fidelity to their interests, and the best services which can be rendered by thorough experts.
For full particulars, address

**AMERICAN AGRICULTURIST
PATENT DEPARTMENT
ORANGE JUDD COMPANY,**
245 Broadway, New York.

WRITES IN HOURS THE HOLDER CONTAINS THE INK 3.50 & 4.00

LANE'S PATENT HOLDER SAVES 1-3 TIME, FITS ANY PEN. \$2 TO \$6 BY MAIL. SEND STAMP FOR CIRCULAR. 66 NASSAU ST. N. Y.

WANTED.—The United States Life Insurance Company is now re-organizing its Agency Department, and is prepared to negotiate with gentlemen of business ability to act as Agents. Previous connection with the business is not considered necessary.
Apply at the Home Office, 261 Broadway, New York. **JOHN E. DEWITT, President.**



FUN FOR THE MILLION.

For little folks and great folks ; for boys and girls, for young men and young women, for fathers and mothers, for grandfathers and grandmothers ; here it is, fun for all ! CRANDALL'S GREAT SHOW—THE ACROBATS. Have you had a box of them ? For a Toy it is one of the greatest inventions of the age. The central figure on this sheet gives the exact size of one of these Acrobats, when put together. The small figures, all about it, are simply suggestions of the almost numberless forms, that an ingenious boy or girl may make up with a single box of the Acrobats. It will be seen that the

central figure is in *seven different pieces*. A box of these Acrobats contains four bodies, four heads, eight arms, eight legs, one flag, and six pieces of wood, or thirty-one pieces in all, and yet from these few elements you can not only make pictures similar to those before you, but *many thousands* of others. The pieces are variously colored, which can not be shown in our ink engravings. They are so grooved and jointed and fitted, that they fasten strongly together in all conceivable positions. These amusing new toys are for sale by the toy dealers generally. They have delighted everybody, young or old, who has seen them. The ORANGE JUDD COMPANY are selling them at \$1 a box, at 245 Broadway, New York, or \$1.15, if sent by mail, pre-paid.

RICH FARMING LANDS

For Sale VERY CHEAP by the

UNION PACIFIC RAILROAD COMPANY

MILLIONS OF ACRES

IN THE

STATE OF NEBRASKA

AT PRICES RANGING FROM

\$2 to \$10 per Acre.

**FIVE AND TEN YEARS CREDIT GIVEN,
With Interest at Six per Cent.**

Convenient to Markets East and West.

The Lands of the Union Pacific Railroad Company are the odd numbered Sections for twenty miles on each side of the road. They are located in the valley of the Platte and its tributaries—a region widely celebrated for its beautiful scenery, rich productive soil, and mild and healthful climate. The winters are short, and the atmosphere dry and invigorating. Epidemic diseases are unknown. The surface is undulating, covered with nutritious grasses, and watered with numerous clear running streams. All the productions of the Eastern and Middle States are grown with success. Wheat and Corn are the staples, and it is well adapted to the cultivation of Fruit. For Stock-raising, in all its branches, these lands are unsurpassed. The Union Pacific and its branch railroads furnish market facilities unequalled. Education is free. One-eighteenth part of the entire area forms a permanent endowment of the Public Schools. Good Society, Schools, Churches, Post-Offices, Mills, Stores, and other advantages of civilization are enjoyed.

The liberal provisions made for Education, the freedom from State debt, the rapidity with which this section is settling, the numerous towns' and villages springing up, offering inducements to the merchant, farmer, and mechanic, render this tract a most desirable location for the industrious man of limited means to secure a comfortable home, and acquire competence, independence, and position.

These lands are granted directly to the Railroad Company. The title given to the purchaser is absolute, in fee simple, free from incumbrances.

They are sold in tracts of forty acres and upwards, giving the man of small means an equal chance with the capitalist to make a safe and profitable investment, one which can not be destroyed by fire or flood, a provision for future support, not affected by *revulsions*, or liable to the fluctuations of stocks.

Full information in reference to particular localities will be furnished, good lands selected, and sales made, free of charge, for persons not desiring to incur the expense of coming to examine the lands in person.

ALSO

THE PIONEER,

A handsome ILLUSTRATED PAPER, with Maps, etc., and containing the HOMESTEAD LAW, mailed free to all applicants, by addressing

O. F. DAVIS,

Land Commissioner U. P. R. R. Co.,

Omaha, Neb.

S. B. Parsons & Sons offer at Flushing, N. Y., Camellias, Azaleas, Roses, and Rhododendrons, and other Trees and Plants.



BABCOCK

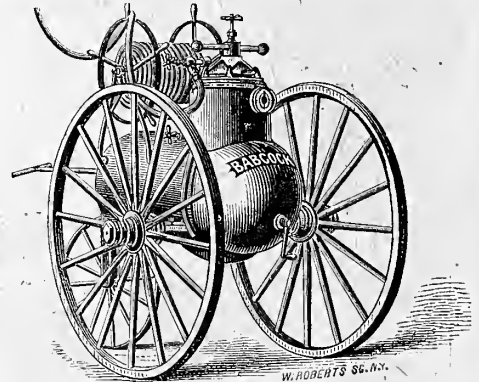

Warehouse Engine,

For Railway Depots, Car Works, Machine Shops, Lumber Yards, Warehouses, Docks, &c. Send for "Record." Engines for Cities and Towns. THE IMPROVED BABCOCK EXTINGUISHERS, for Hotels, Private Residences, Factories, &c. All kinds of Fire Department Supplies.

The Babcock Manufacturing Co.,

407 Broadway, New York; Corner Desplaines and Mather Streets, Chicago.

\$25 A DAY GUARANTEED
using our **WELL AUGER AND DRILL** in good territory. HIGHEST TESTIMONIALS FROM GOVERNORS OF IOWA, ARKANSAS AND DAKOTA. Catalogues free. W. GILES, St. Louis, Mo.

CHICAGO & NORTH-WESTERN RY. THE TRANS-CONTINENTAL ROUTE.

This is the Pioneer line between Chicago and the Pacific Coast, and was the first to connect with the great Pacific roads, and form the OVERLAND ROUTE. This line is the shortest rail line between Chicago and Omaha; the track is of the best steel rail, and is well ballasted, and as free from dust as a road can be made; the bridges are strong and durable; and all the appointments are first-class in every respect. The trains that run over this line are made up of elegant new Pullman Palace Drawing Room and Sleeping Coaches built expressly for this line, luxurious, well lighted and well ventilated Day Coaches, and pleasant lounging and smoking cars; all built by this Company in their own shops. The cars are all equipped with the celebrated Miller Safety Platform, and patent Buffers and Couplings, Westinghouse Safety Air Brakes, and every other appliance that has been devised for the safety of passenger trains. All trains are run by telegraph. In a word, this GREAT CALIFORNIA LINE has the best and smoothest track, and the most elegant and comfortable equipment of any road in the West; and has no superior in the country. It is eminently the favorite route with Chicagoans travelling west, and is acknowledged by the traveling public to be the popular line for all points in Western Iowa, Nebraska, Wyoming, Colorado, Utah, Montana, Idaho, Nevada, California, and the Pacific Slope.

All Coupon Ticket Agents sell tickets by this route. If you are going West, you should try this route.

NEW YORK OFFICE: No. 229 Broadway.
BOSTON OFFICE: No. 5 State Street.

CHICAGO TICKET OFFICES

62 Clark Street, under Sherman House.
Corner Canal and Madison Streets.
Kinzie Street Depot, cor. West Kinzie and Canal Streets.
Wells Street Depot, corner Wells and Kinzie Streets.

MARVIN HUGHITT, W. H. STENNETT,
General Superintendent, General Passenger Agent.

Herbert's Hints to Horse-Keepers.

By the late HENRY WILLIAM HERBERT,
(FRANK FORESTER.)

PRICE, POST-PAID, \$1.75.

A complete manual for Horsemen, embracing: How to Breed a Horse; How to Buy a Horse; How to Break a Horse; How to Use a Horse; How to Feed a Horse; How to Physic a Horse; How to Drive a Horse; Ponies—Different Breeds; Farriers; How to Shoe a Horse; Baucher's Method of Training; How to Ride a Horse; Ladies Riding; Bary's System of Horse-Raising; etc.; and a chapter on Mules and Ponies, etc. Beautifully illustrated.

ORANGE JUDD COMPANY, 245 Broadway, N. Y.

NOVEMBER, 1874.

AMERICAN

AGRICULTURIST

FOR THE FARM, GARDEN & HOUSEHOLD.

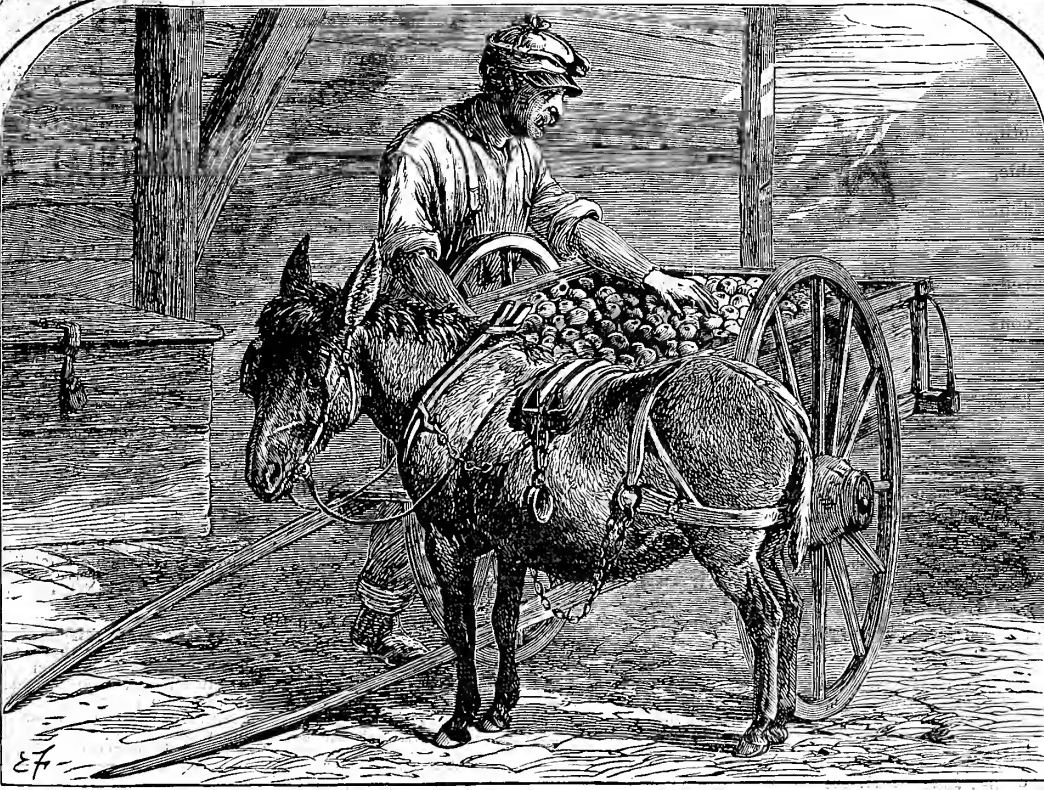

Vol. XXXIII

Number 11

PUBLISHED BY THE
ORANGE JUDD COMPANY,
 245 BROADWAY,
 NEW-YORK.

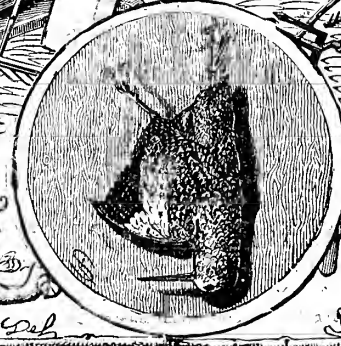

THE REMINGTON WORKS, ILION, N. Y.

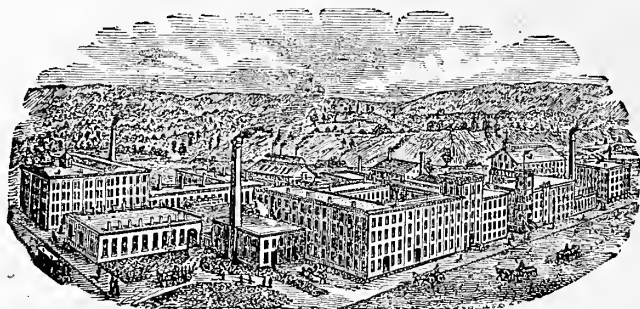

REMINGTON

Sewing Machines, Fire Arms, Agricultural Implements.

The REMINGTON SEWING MACHINE has sprung rapidly into favor, as possessing the best COMBINATION of good qualities, namely: Light running, smooth, noiseless, rapid, durable, with perfect Lock Stitch. It is a Shuttle Machine, with Automatic Drop Feed. Design beautiful and construction the very best.



REMINGTON No. 1 Machine for family use, in the third year of its existence, has met with a more rapid increase of ratio of sales than any machine on the market. REMINGTON No. 2 Machine for manufacturing and family use, (ready for delivery only since June, 1874), for range, perfection, and variety of work, is without a rival in family or workshop.



The REMINGTON WORKS also manufacture the new Double-Barrelled Breech-Loading Shotgun, snap and positive action, with patent joint check, a marvel of beauty, finish, and cheapness—and the Celebrated Remington Rifles—ADOPTED BY NINE DIFFERENT GOVERNMENTS—and renowned throughout the world for Military, Hunting, and Target purposes—ALL KINDS OF PISTOLS, Rifle Canes, METALLIC CARTRIDGES, ETC.



AGRICULTURAL IMPLEMENTS.—Improved MOWING MACHINES, STEEL PLOWS, STEEL HOES, CULTIVATORS, ROAD SCRAPERS, PATENT EXCAVATORS, HAY TEDDERS, COTTON GINS, IRON BRIDGES, ETC.

Good Agents Wanted. Send for Circulars.

BRANCH OFFICES OF REMINGTON COMPANIES.

- Madison Square, 23d St. New York.
- Western Office of the Company, 237 State St. ... Chicago, Ill.
- 258 West Jefferson St. Louisville, Ky.
- 332 Washington St. Boston, Mass.
- 181 West 4th Street. Cincinnati, O.
- DeGives Opera House, Marietta St. Atlanta, Ga.
- 43 Niagara St. Buffalo, N. Y.
- 310 Chestnut St. Philadelphia.
- 617 North Fourth St. St. Louis, Mo.
- Corner North Pearl and Steuben Sts. Albany, N. Y.
- 10 Sixth St. Pittsburgh, Pa.
- New York Office for Arms, 281 & 283 Broadway, New York.

E. Remington & Sons,
Remington Sewing M. Co.,
Remington Ag'l Co. } Ilion, N. Y.

ANDERSON'S STEAM BOILER, AND KIPP'S NEW ENGINE ARE STANDARD, BEST, and CHEAPEST.

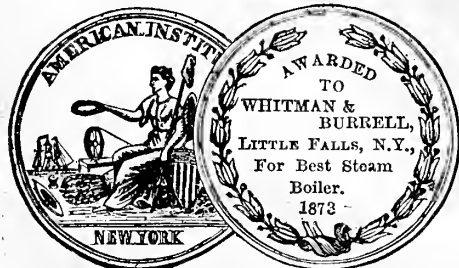

HIGHEST AWARDS, LARGE SILVER MEDAL, at American Institute Fair, 1873, also at Seven State Fairs and Expositions. Simpler, will last longer, safer, and more economical, than any others. Satisfactory Trial given to any responsible parties. SEND FOR CIRCULAR.

French Burr Stone Grist Mills, warranted best in use, for Flour or Coarse Feed.

CHEESE-BOX MATERIAL.—HOOPS FOR TOBACCO DRUMS, 12 to 18 inches wide, 1/4 inch thick. CHEESE AND BUTTER FACTORY APPARATUS and FIXTURES. FACTORIES BUILT AND FURNISHED ON CONTRACT, and best Herkimer Co. Cheese Makers furnished. Correspondence solicited. WHITMAN & BURRELL, Manufacturers and Dealers, Little Falls, N. Y.

Oldest, Largest, Best.



EVERY FARMER OR BUSINESS MAN SHOULD HAVE A Life or Accident Policy. Apply to any agent, or write to the Company, at Hartford, Conn.

1776 1876

INTERNATIONAL EXHIBITION.

OFFICE OF THE U. S. CENTENNIAL COMMISSION, PHILADELPHIA, PA.

In accordance with the several Acts of the Congress of the United States, providing for the celebration of the

CENTENNIAL ANNIVERSARY

of American Independence, there will be held in FAIRMOUNT PARK, Philadelphia, in the year 1876, an

INTERNATIONAL EXHIBITION

of Arts, Manufactures, and Products of the Soil and Mine. The Exhibition will be opened on the 19th of April and closed on the 19th of October.

APPLICATIONS FOR SPACE.

To secure space for exhibits in the Buildings or the Park, early application should be made. The necessary forms for application, together with the Regulations for Exhibitors and needed information, will be forwarded on application to the Office of the Centennial Commission.

A. T. GOSHORN, Director-General.

J. L. CAMPBELL, Secretary.

\$3 to \$5 per Day can be made by Farmers' Sons selling our Window Sash Locks. Put on window in one minute. Retails at 10 cents. Address for Descriptive Circular, LIVINGSTON & CO., Iron Founders, Pittsburgh, Pa.

What are English Channel Shoes?

Sewed shoes have the seam that unites the sole and upper snuck into a channel cut in the sole. Americans cut this channel from the edge of the sole and the thin lip turns up in wearing. The English channel, which never turns up, is cut from the surface, leaving a dark line when closed. As it cannot be cut in thin, poor leather, it indicates a good article.



Readily attached to any Stove. Introduced 8 Years. Thousands in Use. Once used, never dispensed with. Agents Wanted at once in valuable Territory. Circulars on application. American Manufacturing Co., 102 Orange St., NEW HAVEN, Conn.

INVENTORS Who wish to secure PATENTS should write to MUNN & CO., 37 Park Row, New York, for Advice and Pamphlet, 103 pages, FREE.

ADVERTISING RATES.

American Agriculturist.

ENGLISH EDITION.

Inside Pages, \$1.50 per line (agate), each insertion. Open Pages (open without cutting), \$2 per line. Last Page, and 2d and 3d Cover Pages—\$2.50 per line. Page next to Reading and Last Cover Page—\$3.00 per line. No advertisement inserted for less than \$4.50 each insertion.

GERMAN EDITION.

Inside Pages, 25 cents per line, each insertion. Business Notices and Last Page, 40 cents per line. No advertisement inserted for less than \$1.00.

No Advertisement of Medicines or Humbugs received. Address all orders to

ORANGE JUDD COMPANY, 245 BROADWAY, NEW YORK.

AMERICAN AGRICULTURIST

FOR THE

Farm, Garden, and Household.

"AGRICULTURE IS THE MOST HEALTHFUL, MOST USEFUL, AND MOST NOBLE EMPLOYMENT OF MAN."—WASHINGTON.

ORANGE JUDD COMPANY,
PUBLISHERS AND PROPRIETORS.
Office, 245 BROADWAY.

ESTABLISHED IN 1842.
Published also in German at \$1.50 a Year.

\$1.50 PER ANNUM, IN ADVANCE.
SINGLE NUMBER, 15 CENTS.
4 Copies for \$5; 10 for \$12; 20 or more, \$1 each.

Entered according to Act of Congress, in October, 1874, by the ORANGE JUDD COMPANY, at the Office of the Librarian of Congress, at Washington.

VOLUME XXXIII.—No. 11.

NEW YORK, NOVEMBER, 1874.

NEW SERIES—No. 334.

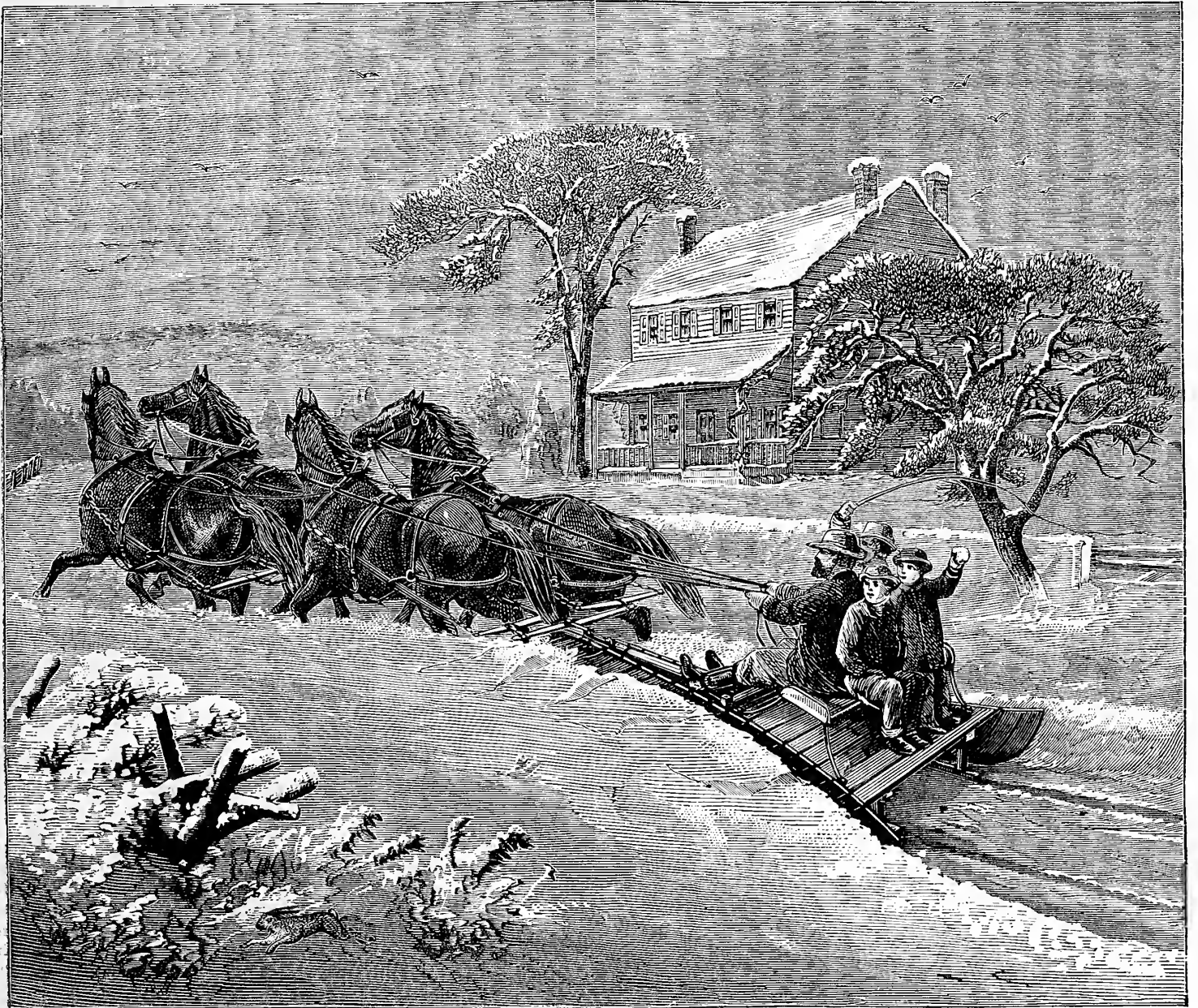

THE ROADS IN WINTER. — USE OF THE SNOW PLOW. — Drawn and Engraved for the American Agriculturist

We could never understand why it is, that in those parts of the country where deep snows prevail, some efforts are not made by the town authorities to keep good roads during the winter. In the spring and summer the roads are repaired, and some efforts are made to keep them passable. But when the first heavy snow of the season falls, and on every similar occasion afterwards, it is the business of those who are compelled to go out first to break the roads, and those who can wait, do so until others have made the roads passable. Then a narrow single track is made, along which only one

team at a time can pass, and if two meet, one must turn out into the deep snow, at the risk of upsetting on the piled-up bank, or in a convenient ditch. Such, at least, has been our experience, and to remedy this inconvenience, we have often turned out with a snow-plow, to do individually, what ought to have been the road-master's work, or at least that of the associated neighbors. At such times we have improved on the usual plan, by making double tracks, thus rendering turning out in the snow for passing teams unnecessary. The snow-plow used for this purpose is shown in the illustra-

tion given in this article. It should be loaded as heavily as possible, and two pairs of horses should be used with it, so that the snow will be packed down firmly, and a well-beaten track made. Breaking roads in the snow is always a favorite job with the boys, and volunteers are never wanting. The chief thing is to procure the plow. As we have suggested, this should be provided by the road-master of each district, whose business it should be to turn out with it after each heavy fall of snow, and clear the roads. A description of the manner of making the plow will be found on page 412.

Contents for November, 1874.

Beans, Dreer's Improved Lima... Illustrated... 430
Bee Notes for November... 410
Boys and Girls' Columns—Horse Trees—Hornets'
Hoop—Aunt Sue's Chats—Aunt Sue's Puzzle-Box—
Marmots, Tame and Wild—Popping Corn—About
Secrets—Puzzle Picture... 6 Illustrations... 427, 428
Bulbs, Buying and Planting... 423
Catalogues Noticed... 409
Cauliflower, How to Grow... 423
Cows Compared, Ayrshire and Native... 2 Illustrations... 413
Ducks as Layers, Pekin... 418
Erasour, The... Illustrated... 417
Farm Signal... Illustrated... 417
Fence, Rat Proof... 2 Illustrations... 419
Flowers, Abutilon—Boule de Neige... Illustrated... 421
Flower Auctions, New York... 409
Flower Garden and Lawn in November... 403
Flowers, Lindley's Ruddleya... Illustrated... 424
Flowers, Preserving... 424
Fruit Garden in November... 403
Greenhouse and Window Plants in November... 403
Greenhouses, Heating by a Flue... Illustrated... 422
Halter, How to Make... Illustrated... 418
Horses, Various Breeds of... Illustrated... 420
Household Department—Useful Piece of Furniture—
Household Carpentry—Home Topics—Soups
... 5 Illustrations... 425, 426
Ice Ponds, Temporary Dam for... Illustrated... 416
Kitchen Garden in November... 403
Leaves, Gathering... Illustrated... 416
Market Reports for November... 404
Notes from the Pines—Grapes... 422
Ogden Farm Papers, No. 57—Farming on Paper—
Clover—Soil Analyses—Deep Can System—Criticism
—Sheep... 410, 412
Orchard and Nursery in November... 403
Plants, Coral Roots... Illustrated... 424
Plants, Rose Mallows... Illustrated... 421
Poultry, Preparing for Market in France... 419
Rhubarb, Great Yield... 423
Roads in Winter... Illustrated... 401
Sheep, Native Breeds of... 419
Sheep Raising in Virginia... 418
Shrubs, Hydrangea paniculata grandiflora... 423
Slaughtering Time, Aids at... 6 Illustrations... 418
Snow Plow, How to Build... Illustrated... 412
Stables, Ceiled... 417
Stack Bottom, How to Make a... Illustrated... 415
State Fairs... 409
Steamer, Portable Food... Illustrated... 416
Trees, Method of Climbing... 2 Illustrations... 409
Walks and Talks Correspondence... 409
Walks and Talks on the Farm, No. 131—Pigs—Corn
Fodder—Fat Cattle Show—Silesian Merino Lambs
—Holstein Cattle—Sheep—Pigs—Wheat... 414
Water Stored for Irrigation, Emptying... Illustrated... 412
Work, Hints About... 402

INDEX TO "BASKET," OR SHORTER ARTICLES.

Advertisers and Readers, Harrow, A Perfect... 407
To... 405 Horse, Noise in Abdomen... 405
American Garden... 406 of a... 408
Barley, Cultivation of... 408 Jersey Herd, Sale of... 408
Beef Clubs... 407 Lands in Eastern Va... 408
Bone and Blood Spavin... 408 Lands in Iowa... 408
Bone-Dust, Shipment of... 407 Lands in Nebraska... 408
Book on Diseases of the Land, Reclamation of... 408
Horse... 406 Lily, Choice Species and
Breed, Failure to... 408 Varieties of... 407
Briek Machine... 407 Manure, Preservation of... 407
Carbolic Acid in the Orange Culture, Florida... 405
Dairy... 407 Phosphates, S. C... 408
Castings for Implements... 406 Pigeons... 408
Cattle, Aphtha in... 407 Pigs, Sore Eyes... 407
Cheese Press... 408 Plaster, Preparation of... 408
Colts, Half-bred... 408 Plow, Swivel... 408
Compost Heaps... 407 Potash in Compost... 403
Curd, Floating... 407 Power, Sweep or Tread... 407
Dairy in Colorado... 408 Pump, What is a Good... 405
Death of an Editor... 405 Receipts, Choice... 407
Death of Mr. Bloomer... 405 Replies, Delayed... 405
Ditching Machine... 408 Roofing, Asbestos... 405
Exports and Imports... 406 Roofing, Canvas... 407
Farmer's Book, A... 405 Salsify... 407
Farms in the East, Salt as a Fertilizer... 408
Abandoned... 408 Salt, Pure... 406
Feed, Scalding... 408 Salt Upon Wheat... 407
Field, Cover, and Trap... 405 Schoolmaster's Trunk... 405
Shooting... 407 Sheep, Deterioration of... 406
Fodder, Preserving Green... 400 Sheep, Fencing... 407
Food for Store Hogs... 407 Sheep, Pasturing... 407
Cheap... 407 Stable for a Colt... 408
Fowls, Roup in... 408 Sundry Humbugs... 405
Gardener, A Competent... 405 Texas Cattle Trade... 408
Grain, New Market for... 408 Toes, Eight on one Foot... 407
Guano for Grass... 408 Trout in Hard Water... 407

Calendar for November.

Table with columns for Day of Month, Day of Week, and sunrise/sunset times for Boston, N. York, Philadelphia, N. Jersey, Penn., Ohio, Indiana, and Illinois, and Washington, Maryland, Virginia, Kentucky, Missouri, and California.

PHASES OF THE MOON.

Table showing moon phases (New, 1st, Full, 3d) for Boston, N. York, Wash., Phila., St. Louis, and Chicago.

AMERICAN AGRICULTURIST.

NEW YORK, NOVEMBER, 1874.

At the present time the course of the markets is closely studied. When to sell, is a serious question with farmers. Hitherto they have frequently had the mortification to see their grain pass from their hands at low prices, which have been brought about by combinations of speculators and dealers. These persons, as soon as they had secured the grain, have put up prices and cleared millions of dollars, which by right ought to have gone to the farmers' pockets. At the present time the market has been influenced by false reports of enormous crops in Europe, and grain has been sold for delivery several months ahead, at prices which will not pay the cost of raising it. The London Mark Lane Express, speaks of "low stocks at present with no room for decline, and that every exporting country complains bitterly of English rates." This means higher prices, and if grain is not forced on the markets, we do not see how they can be prevented. Fortunately farmers are becoming better able to act in their own defence, and having learned to combine for this purpose, may set their own price on their products, and demand the fair value for their labor. Some commercial papers pretend that this is an improper thing to do; that it is next to criminal for farmers to set a price upon the world's food. That they should sell at the earliest moment their grain is ready for market, and take the current price for it. But what other producers do this? None. All other producers fix their prices, and hold their produce for them as long as they are able. And this the farmer has a right to do. No other man may fix the price for the farmer's labor. To do that is his own personal privilege. But to be able to watch his own interests closely, and protect his privileges, the farmer must keep "posted." He must be a reading man. It is by reading, more than by practical experience, that men become educated; and a man's education is not finished while he lives. One's own experience is narrow. When one reads, he gathers the accumulated experience of hundreds or thousands. The farmer therefore must read papers. His local paper, as a matter of course, should be read, because every farmer should interest himself in his own local affairs, and make his weight felt socially and politically. This is his duty to himself and to his neighbors. But in addition, he should read

some paper in which he may get a general view of affairs in which he has an interest. The American Agriculturist located in a central point, with editors and contributors who are engaged in agriculture in widely distant parts of the country, has the best facilities for giving a general view of agricultural matters of the greatest value to farmers everywhere. It enters into no competition with local papers, but acts with and for them. And it is only as far as farmers read and study the best papers more and more, that they will be enabled to act in concert with each other, understandingly and effectively. In union is strength, but that strength is useful only as it is wisely used.

Hints about Work.

The first work to be done, is to attend to the comfort of the farm stock, neglecting none. Probably these have been neglected in the hurry of harvesting and storing crops. They should now be looked to. Every loose board upon the stables and sheds should be tightly nailed, the open cracks should be battened, openings in the caves should be closed, windows and roofs repaired, broken floors made sound, and some extra feed provided. If fodder is short, it is economy to keep the stock warm and dry, and feed liberally before severe weather comes. Animals in good condition, will be able to stand some hardship in the spring, and come out better than those that are stunted now, and given extra care then. It is a difficult matter to bring up poor stock when spring is coming on.

Horses.—Provide blankets for the horses. A warm blanket will save feed and loss of time by sickness. Avoid exposure to cold rains, and if caught in a storm, let the horses be rubbed dry before the blankets are put over them. Keep the stalls clean, and on no account allow manure to gather beneath the horses' feet. This injures the hoofs, and often produces cracked heels. Besides, it renders the air foul, and is very injurious to the animals' eyes. In the effort to keep the stable warm, proper ventilation should not be neglected. The curry comb and brush should not lie idle; their use invigorates the skin, and promotes healthful secretions.

Cows.—Milking cows will now need extra feed. On the whole, more value in milk will be returned from bran than from any other feed—not the light husks, but what is known as bran at country mills. A winter dairy well managed, may be made more profitable than a summer one. Dry cows should be kept in good condition. They are now storing up material for future profit. The future value of the calf too, depends upon how the dam is fed before its birth. Bran is excellent feed for in-calf cows, and it is cheap now. It is well not to waste time in milking cows that give only a quart a day, but it will be better to dry them off.

Young Stock.—All young animals need liberal and kindly treatment, and watchful care. The farmer's eye should ever be on the alert to discover the first sign of disorder, and when found, it should be remedied at once.

Sheep.—No stock suffer more from damp close quarters, than sheep. They will winter better in the open field, than in a low damp filthy yard. But they should be spared either of these afflictions. An open shed that may be closed in driving storms ought to be provided, with a roomy yard in which they may lie in fair weather. Oats and corn are both dear this season, and bran, rye, or buckwheat, may be given with equal profit. A little variation of feed is good for sheep, but the changes should not be made frequently, or they will learn to look for it and become dissatisfied. Frozen grass or any cold watery feed is bad for ewes that are to lamb early.

Breeding Ewes, to lamb in April, should be put with the ram this month. From this time their feed should be gradually increased.

Lambs, and yearling ewes that are not to be bred from, may be put together and kept separate from the other sheep. If any of the flocks have the scours, a table-spoonful of a mixture of prepared

To Purify a Cistern.—"D. L. B." Morrisania, N. Y. The best plan, probably, to purify the water in a cistern is to put into it a basket, net, or sack, containing a bushel of fresh charcoal. If there is a filter in the cistern, it should be taken out and cleansed.

chalk and peppermint in water, should be given once a day. Costiveness is quickly remedied by a little linseed oil-cake meal.

Swine.—Fat hogs should be finished up as fast as possible. Those intended for home use, should be finished upon dry shelled corn, with pure water only for drink. This will produce firm hard pork. Store hogs will do best upon cooked food, and in place of corn, boiled potatoes and bran will make excellent feed. Buckwheat is too heating food for pigs, and should be avoided. Brood sows may have the company of the boar, if pigs are wanted in March. The increased value of the first litter of pigs, will pay for a pure bred boar. Nothing is more certain than that it pays to breed only from pure blooded males, of whatever kind or breed they may be. But blood will not stand in place of feed. Blooded pigs are most profitable and thrive best where there is a full corn crib.

Storing Roots.—Root crops and potatoes should be stored in dry pits, in preference to cellars beneath the house. Ventilation should not be neglected; wisps of straw should be placed in the tops of the pits every six feet apart, for this purpose. If any are still in the ground, they should be harvested without delay. A good substantial and permanent root house in a convenient place, will be found valuable.

Roads.—Repairing roads should not be put off any later. Every farm should have a permanent road through the center, which should be kept in good repair. Roadmasters should see that mud-holes and bad spots in the roads are filled with broken stone. Mending roads with earth at any season, is waste labor. There should be a Blake's Stone Crusher at every country mill where road material can be procured. One year's use would pay for it. In nothing are we so behind the times as in the condition of our country roads.

Sundry Matters.—Upon stormy days there will be found plenty of occupation in repairing harness, cleaning and putting away tools, working in the carpenter's shop, repairing grain bags, etc. Such work is recreation. As this is the season for selling poultry, let there be a good supply kept for home use, and those which are kept for breeding, should be well cared for, so that they may lay early. The poultry house should be kept clean and well white-washed, if it has not been already done. Keep the plow running in the corn stubbles until the ground is frozen. The long winter evenings should be devoted to study and domestic entertainments; in which the younger should be joined by the older ones. There are few things which will more readily make farm life agreeable to children, than the pleasant evenings which may be spent in a farm house, with books, papers, toys, and games, in which the old folks renew their youth again. It is the want of this companionship, which makes country life so generally dull and uninviting to young people.

Work in the Horticultural Departments.

If advantage was taken of the pleasant October, gardening operations will be pretty well advanced by the first of this month. Do not delay any work which must be done before hard frosts set in, because November weather is very deceptive, and a change from mild to freezing temperature, is often only a matter of a few hours. The gardener should have learned something new about his business if he has had his eyes open, as all intelligent men should have, and another year ought to find him advanced both in the science and art of gardening. No horticulturist should be content to plod on in the same path year after year, raising the same crops, and pursuing the same hum-drum sort of life; on the contrary, he should strike out into new paths, try new varieties of seeds and plants as far as his means will allow, and so put the energy and talent into his work that business men do into their's. We should then hear less of boys leaving their homes for the city, where 95 out of every 100 fail in business. Papers and books should be provided for the long winter evenings.

Orchard and Nursery.

Planting may often be done this month where the weather is mild, but on no account set the trees in partially frozen soil; it is much better to heel-in the trees in a dry sandy spot until spring, when they can be set out properly.

Stocks for root grafting should be taken up, assorted, and tied in bundles of convenient size, and stored in boxes of damp sawdust in the cellar, where they can be easily reached during the winter.

Cions may be cut at any time when the wood is not frozen; store in saw-dust, and take care that they do not dry out during the winter.

Seedlings.—Give protection, but not until the weather is quite cold; if applied too early, growth sometimes occurs.

Leaves.—Collect and store as large a supply of these as possible, for covering and bedding; see article on gathering them, on page 416.

Fruit should be kept in rooms or cellars where the temperature is as even as possible, the nearer it is to 35° or 40° the better will the fruit keep.

Plowing.—All plowing should be done early this month; ground for new orchards will be in much better condition for planting, if plowed in the fall.

Fruit Garden.

Pears of choice varieties well preserved, will now bring good prices in the markets. If packed in shallow boxes, containing one or two layers, and each pear wrapped in soft tissue paper, the extra price will more than repay the trouble.

Covering.—Try to cover strawberries, etc., just as freezing weather sets in; this is easily done if the covering material is at hand. Young grape vines are best covered with a few inches of earth.

Root Cuttings.—Blackberries and raspberries are most readily propagated from root cuttings. The roots are cut into pieces two or three inches long, and packed closely in a box with earth; there should be holes in the bottom of the box to allow of drainage, then bury the box and contents in a dry spot, and leave until spring.

Cuttings of currants and gooseberries may be planted. The one thing necessary to insure success, is that the earth be packed firmly around the base of the cuttings.

Grape Vines.—Prune at once before cold weather sets in, many persons do not prune until spring; if left until then, the vines are liable to bleed. The various methods of pruning have been described, and it makes but little difference which is adopted.

Grape Cuttings.—The wood from the pruning of the grape vines, may be used for propagation. Cut into pieces containing two buds, and tie into convenient bundles, and bury in sand in the cellar. Varieties hard to start, like the Delaware, should be rooted in the greenhouse or hot-bed from one-eye cuttings, while others, like Norton's Virginia, can only be profitably multiplied by layers.

Kitchen Garden.

In the more Northern localities, but little can be done in the garden this month, except plowing and hauling out manure. All land not planted, should be plowed or spaded in the fall if possible, as it can be much sooner worked in the spring.

Asparagus.—Cover the beds with a good dressing of coarse manure, straw or litter. Burn the seeds if they are not wanted for new plantings.

Roots.—Place in pits as recommended for last month, but do not cover with earth until the weather renders it necessary. The hardier roots, such as parsnips, salsify, horseradish, etc., may be dug as long as the ground remains unfrozen.

Manure is the basis of good crops in the garden, and most farmers would be surprised at the quantity applied to an acre by our market gardeners. Every method should be used to increase the supply. Gather leaves, woods' earth, swamp muck, to be used as absorbents for the liquid manure of the stables or the house slops; sods and loam should be carted to the barn-yard, for use in the stables.

Rhubarb.—Transplant now, rather than in the spring. Give an abundance of manure.

Cold Frames should be ready for cabbages and other plants wintered over. Do not cover until freezing weather comes, and then only put on the sashes at night.

Celery.—Store in trenches a foot wide, and as deep as necessary to contain the plants. Put the roots close together and cover with straw, gradually increasing the thickness as the cold increases.

Cabbages.—The best way to preserve these, is to invert the heads and cover with four to six inches of earth; this should be left as late as the earth can be worked.

Spinach.—Give a slight covering of leaves or hay, just as the ground begins to freeze.

Soil.—Prepare a quantity of this for use in the hot-beds next spring. It is usually difficult to get soil at that time, and it is much better to have a supply ready for use, stored under a shed or in the cellar. A light sandy loam is best, and if too heavy, mix a third part of sand with it, and add a little well rotted manure. The whole pile should be thoroughly mixed, and placed in a heap under cover.

Flower Garden and Lawn.

There is but little to add to our notes of last month, in this department. Everything should be done to help along the work of the coming spring.

Planting of many things can be done this month as well as in the spring, as long as the ground remains open. Trees and shrubs may be moved readily now, and many kinds which start early, are better transplanted now than in the spring.

Bulbs.—If not planted last month, do not delay doing it at once. Take up Gladioluses and other tender bulbs. Cover all bulb beds with a coating of straw or leaves.

Protection.—Give some protection to all half-hardy plants, and even herbaceous plants that are quite hardy, are greatly benefitted by a slight protection.

Lawns.—If the grass shows signs of failing, apply a dressing of fine, well rotted manure. Where the grass has died out, sow fresh seed, and rake it in smoothly and evenly.

Perennials.—It is not yet too late to divide and replant old plants.

Greenhouse and Window Plants.

Insects.—Look out that no plants are put into the greenhouse which are covered with insects; the only way to keep the house free, is never to let them get in.

Bulbs potted and placed in the cellar, may be brought out from time to time, if they have made good roots.

Camellias.—Keep the plants in a cool room, where they can develop their buds properly. Syringe often to keep the foliage healthy.

Propagate such plants as it is desirable to have for winter blooming, or for setting out, or for sale in the spring.

Climbers are necessary in a greenhouse to provide shade for the other plants. Passifloras, Roses, Tropæolums, etc., are all valuable for this purpose.

Annuals.—Sow seeds of a few free flowering ones for winter flowers. Sweet Alyssum and Mignonette are good bouquet plants.

Lobelias.—If the low growing sorts were planted in the flower-garden during the summer, a portion should be taken up for planting in pots or pans for winter flowering.

Ferns are liable to become infested with red-spider and scale, and if they are not watched closely they will soon perish, at least the more tender sorts. This month is a good time to divide such plants as are capable of division.

Forcing.—Provide plants of Dicentra, Candytuft, Deutzia, and other plants desired for winter flowering, and store in the cellar.

Commercial Matters—Market Prices.

The following condensed, comprehensive tables, carefully prepared specially for the American Agriculturist, from our daily record during the year, show at a glance the transactions for the month ending Oct. 13th, 1874, and for the corresponding month last year:

TRANSACTIONS AT THE NEW YORK MARKETS. RECEIPTS. Flour, Wheat, Corn, Rye, Barley, Oats. 25 d's this m'th 3,331,000 3,214,000 1,711,000 103,000 117,000 802,000 25 d's last m'th 3,619,000 3,571,000 1,977,000 54,000 28,700 738,000 SALES. Flour, Wheat, Corn, Rye, Barley, Oats. 25 d's this m'th 3,037,000 4,807,000 4,218,000 48,000 129,000 1,911,000 25 d's last m'th 3,818,000 5,143,000 4,716,000 26,000 86,000 2,304,000

CURRENT WHOLESALE PRICES.

Table of current wholesale prices for various commodities including Flour, Wheat, Corn, Rye, Barley, Oats, and other agricultural products. Columns include item names and prices for different months (Sept. 12, Oct. 13).

considerable speculative inquiry, closing buoyantly. An unusually free movement has been recently in progress in Oats, in good part for forward delivery, at advancing figures... The Provision trade closes up rather tamely and heavily, the speculative demand having fallen off materially... Cotton has been more freely dealt in, but at reduced quotations, closing, however, more steadily... Wool has been in less confident demand, and at the close somewhat less firm in price... Tobacco has been in lively request at higher rates... Hops have been active and firm, the main inquiry having been on export account... Seeds have been rather more sought after on the basis of our quotations... Hay and Straw have been attracting more attention, closing more firmly.

New York Live-Stock Markets.

Table showing receipts for live stock markets including Beef Cows, Calves, Sheep, and Swine. Columns include week ending, receipts, and average prices.

Beef Cattle.—At the opening of the month's business the inferior quality of the offerings made a dull market, although no appreciable falling off in prices could be marked. A repetition of this the next week tended to lower the market, and a fall of fully 1/2 c. per lb. had to be submitted to. The market continued to be overburdened with poor cattle, and sales were made at 6 cents against 7 cents for the poorest at this time last year. To do a losing business did not suit the views of dealers, and 20 cars of Texans were held back at Harrisburg. This helped to raise the average greatly, and with some of the best extra cattle of the season the market was lively, but prices were not notably better. At the close native steers ranged from 8 1/2 c. @ 12 lb., to dress 55 lbs., up to 13c., to dress 58 lbs. A few of the finest sold up to 13 1/2 c., to dress 58 lbs. Texans and Cherokees brought 6 1/2 @ 8 c. @ 12 lb., to dress 54 @ 55 lbs., and 9 1/2 c., to dress 55 @ 56 lbs. to the gross cwt. A year ago we had the largest receipts of the season, and prices fell off 1 c. @ 12 lb., the best steers selling at 12 to 12 1/2 c. @ 12 lb.

The prices for the past four weeks were as follows:

Table showing prices for the past four weeks for Milk Cows, Large Sales, and Average prices.

Milk Cows.—There has been a good demand for cows all through the past month, which, with light receipts, put up prices at least \$5 per head. Fancy cows have been in demand, and a car-load from Ontario Co., N. Y., brought from \$75 to \$129.50 per head. Sales have been at \$50 @ \$80 for fair cows, calf included, and \$100 and \$129.50 for two extra fancy cows... Calves.—The market for calves has gradually dulled through the month, and closes duller than before, without much change in prices however. Milk-fed veals are selling at 7 to 10 c. @ 12 lb., and grassers at \$5 to \$10 per head....

Sheep and Lambs.—Sheep have been steady and lambs active through the past month. Prices have been firm, with an advance for lambs. At the close sheep ranged from 4 1/2 @ 6 1/2 c. @ 12 lb., and lambs sold at 6 1/2 c. to 8 1/2 c. @ 12 lb.... Swine.—A large business has been done in hogs, with a weekly average of 10,000 head over last month. Prices have fallen off, and at the close sales were made at 5 1/2 @ 6 1/2 c. @ 12 lb., and 8 1/4 @ 8 1/2 c. for dressed.

The Texas Cattle Disease.—In Several parts of Connecticut and in Lewistown, Pennsylvania, many cattle have died of late of what is known as the Texas cattle disease. Not that Texas cattle die of this disease, but that those native cattle, which are pastured along with or after Texas or Cherokee cattle, are seized and die with it. The disease is very similar to that well known as "splenic apoplexy," and consists in a general disorganization of the blood, and congestion of the spleen and kidneys. The bladder is also filled with a dark, blood-like fluid. The infected cattle are covered with cattle ticks, which is sufficient to show that they had been brought into contact with Texas cattle. In the case which occurred in Pennsylvania, which was described to us by one of the persons interested, it was wrongly supposed that the presence of the ticks in the stomach and intestines (and as was also stated in the kidneys) was the cause of death. That the ticks were found in the intestines simply shows that the animals, in licking themselves to get rid of these tormentors, had swallowed many of them. But they have no serious effect, if any at all, upon the animal when swallowed. In the kidney, which was sent to us and which we examined, there was nothing more than the usual dark-colored congested patches, the small hard nodules supposed to be ticks, or caused by ticks, were merely small calculi or stones,

which are so frequently found in the kidneys of cattle. There is nothing new in these cases. Thousands of similar ones have occurred in the West, and the precaution of avoiding contact with Texas or Cherokee cattle is sufficient to prevent the disease. Neither is there so great an anomaly as is supposed in the fact that other cattle die of this disease, which is not fatal to a Texas steer. That animal is acclimated, and is therefore exempt from the fatal effects of the disorder to which others at once fall victims. The disease is probably communicated by means of the urine, dung, or saliva, of the Texans upon the pasture, which is picked up by the animals which feed with them or after them. There is no readier means of conveying infection than these. If this disease is to be shut out from the Eastern States, the precautions observed in the West must be adopted, viz.: prohibiting the driving of Texas cattle upon the public roads, or pasturing them in fields except in those months when frost is frequent. The infection is destroyed by a freezing temperature. As prevention is so perfectly safe, it is useless to prescribe any doubtful remedies, the more so, as the first intimation that the disease is present, is the death of the infected animals in almost every case. We learn that Prof. Crossy, of the Massachusetts Agricultural College, along with the Hon. T. S. Gold and E. H. Hyde, the State Commissioners of Diseases of Domestic Animals of Connecticut, have made some investigations, but these have resulted in no new developments, and no fresh light has been thrown upon the question of the causes or treatment of the disease.

Something Worth Looking Into By Every One. See Page 433.



containing a great variety of items, including many good hints and suggestions which we throw into smaller type and condensed form, for want of space elsewhere.

Remitting Money: — Checks on New York City Banks or Bankers are best for large sums; make payable to the order of Orange Judd Company. Post-Office Money Orders for \$50 or less, are cheap and safe also. When these are not obtainable, register letters, affixing stamps for postage and registry; put in the money and seal the letter in the presence of the postmaster, and take his receipt for it. Money sent in the above three methods is safe against loss.

N.B.—The New Postage Law.

—On account of the new postal law, which requires pre-payment of postage by the publishers, after January 1st, 1875, each subscriber, whose subscription runs over into the next year, must remit, in addition to the regular rates, one cent for each month over which his subscription extends in 1875, or ten cents for the whole year 1875. Every subscriber, whether coming singly, or in clubs at club rates, will be particular to send to this office postage as above, that is, at the rate of ten cents for the year, additional to the regular subscription. Subscribers in British America will continue to send postage as heretofore, for pre-payment here.

Bound Copies of Volume Thirty-two are now ready. Price, \$2, at our office; or \$2.50 each, if sent by mail. Any of the last seventeen volumes (16 to 32) will also be forwarded at same price. Sets of numbers sent to our office will be neatly bound in our regular style, at 75 cents per vol. (50 cents extra, if returned by mail.) Missing numbers supplied at 12 cents each.

Subscribe this month, and get the December Number FREE. Read "A Bit of History," and "The Result" on p. 433 and following pp.

Gold has been up to 110%, and down to 109 1/2, closing October 12th at 110 1/2, as against 109 1/2 on September 12th... Business in most kinds of domestic produce, has been comparatively brisk, but at irregular and quite generally lower prices. The Breadstuff trade has been on an extensive scale, with the purchases of Wheat, Corn, and Flour, largely on export account, at, however, unsettled rates, closing generally rather in favor of buyers, notwithstanding the lighter arrivals, or the lower range of ocean freights. Rye has been more sought after toward the close, partly for shipment, and has been quoted firmer. Barley has also been more active, with

Our Western Office.—Our friends in the West are reminded that we have an office at Lakeside Building, Chicago, Ill., in charge of Mr. W. H. Busbey. Subscriptions to *American Agriculturist* are taken there, and sample copies of the paper and chromo are delivered, and orders received for advertising on the same terms as in New York. All our books are on sale at the Western Office. Please call and examine, buy, subscribe, and advertise.

The American Agriculturist in German.—We ask the kind attention of our readers to the fact that this paper is also printed in *German*. Many of them may have friends, or neighbors, or working men of that nationality, who would be glad to secure such a Journal as this. The more important articles and the same illustrations are contained in the German edition, with a Special German Department by Hon. Frederick Münch, of Missouri, and the rates, single and club, are the same as for the English edition.

Delayed Replies.—"C. G. M. B.," Detroit, Mich. Letters of inquiry that may be received after the 10th of any month can not be replied to in the next month's *Agriculturist*, and have to lie over until the second month. This is one of the necessities in the publication of a monthly paper, and we request our friends to remember that there are other unavoidable exigencies that will prevent immediate replies to their queries. Important matters, *as far as possible*, will be answered by mail; the most important have the preference.

To Advertisers and Readers.—There is no doubt that the columns of the *American Agriculturist* furnish by far the best general medium for advertising anywhere to be found, and for several reasons: It is universally conceded by advertising agents that no other Journal is so absolutely strict in shutting out any and all advertisements and advertisers of an unreliable character, and those in any way objectionable, such as medical, etc. If the rules in this respect were let down for a single year, it would bring a hundred thousand dollars to the publishers, as the class shut out—those who give the least, or nothing, or worse than nothing, for the money they receive, can and do pay the best prices and largest sums for advertising. . . . Many advertisers ask for an editorial "notice" or reference. It should be understood that the advertising pages are *edited*, and the admission of an advertisement at all, is as good as an editorial endorsement in other papers. . . . The immense bona-fide circulation, the permanent character of the paper, each number of which is before the reader for a whole month, and very often for years, is another valuable feature. The fact that this paper is largely loaned or exchanged among neighbors, so that very often 20 to 30 adult persons read a single copy, is another element. If a loose card of 20 lines were to be sent with each copy of the paper, it would cost many times as much to barely print it, as it now costs to electotype such a card permanently in the pages where it will not fall out, and where it will be seen by every reader.—OUR READERS will always be profited by looking through our business pages to learn what is for sale, by whom, etc. Many good suggestions are thus received by those who do not want to buy anything.—We respectfully suggest that when our readers write to any of our advertisers for circulars, or to order of them, or make inquiries, they will let them know that the advertisements were seen in this Journal. It will be of triple advantage—to themselves, to advertisers, and to the publishers.

A Competent Gardener, will change his situation next spring. We refer to Mr. Louis Guerinneau, who has for several years been the gardener at the Botanic Garden, Cambridge, Mass., during which time, as well as before, we have had frequent occasion to know of his ability in his profession. Besides being proficient in gardening in all its departments, Mr. G. has a knowledge of botany rarely to be found associated with ability as a practical gardener, and would be most valuable to an Agricultural College, where there is a botanic garden, or in any similar situation. Mr. G. may be addressed as above, and has permission to refer to the Editor of the *Agriculturist*.

What is a Good Pump?—G. Timson. Our own experience in the matter of pumps for an ordinary well is very limited, but such as it we give it. Having concluded to put in a pump early this spring, the next point was to decide upon the kind. Knowing that our next neighbor had a pump in use for some two years, and that another about a mile off had upon his place two pumps of the same kind, which he had used much to his satisfaction for some four years, we concluded it would be well to profit by their experience, and get a similar pump, which was the American Submerged. This was put in early this spring, and has been in daily use ever

since, and certainly for ease of working, and for power, it is not easy to conceive of a more satisfactory well pump. By attaching a hose, a good stream of water can be thrown upon the house, but we hope not to be obliged to test its utility as a force-pump for any other work than washing carriages. The pump itself being below the surface of the water, cannot freeze up, and the pipes used are enamelled upon the inside and outside with a coating upon which, it is claimed—and we think with good reason, that neither water, or any other liquid, has any action. So, combining our own experience with that of our neighbors, we have no hesitation in saying that the American Submerged is a "good pump."

Don't fail to Read the Premium List, see pages 433 to 437.

A Farmer's Book.—"W. A. G.," Highlands, N. J. Allen's new American Farm Book, price \$2.50, would be a very suitable book for a young man to study, who wants to learn farming. It may be procured at this office by remitting the price.

Death of an Editor.—Mr. John S. Wright, the founder of the *Prairie Farmer*, and one of the early settlers of Chicago, died recently at the age of 59. The Chicago papers speak in high terms of his personal qualities, as well as of his great influence in making that city what it now is. He ceased his active editorial duties in 1857 or '58.

Orange Culture in Florida.—A series of letters that were written by J. H. Fowler, of Port Orange, and printed in the *Florida Agriculturist*, has been published by C. H. Walton & Co., in a pamphlet form. We read the letters as they appeared, and have no doubt that this will prove a useful as it is the only work on Orange Culture yet published in the country. Price 25 cents.

Death of Mr. Bloomer.—A private letter from one of his associates informs us that Mr. H. G. Bloomer died at San Francisco late in September last. Mr. B. did much to develop the botany of California, and is commemorated in a genus, as well as several species, among which is *Lilium Bloomerianum*. At the time of his death Mr. B. was Curator of the California Academy of Natural Sciences.

Asbestos Roofing.—"G. T." We have Johns' Roofing in use, it has been on about two years, but not long enough for us to say how many years it will last. Thus far we are quite satisfied with it, and though we have advertised it from the beginning, we have not yet received a single complaint.

The Schoolmaster's Trunk.—This is a reproduction of a series of articles written a year or more ago for *Heath and Home*, by Mrs. A. B. Diaz, published by J. R. Osgood & Co. Every one who lives in a village, as well as every one who does not, will find amusement here, and more than that, abundant food for thought. It is rare that the relations of neighbors, and the "rights" of women are touched by so clever a hand. We read the papers as they appeared, and again in the volume, which is as high a compliment as we can pay to any work. Read it, and see if *Tweentit* is the only place where the rolling pin is making slaves.

SUNDRY HUMBUGS.—The changes, which the times and seasons bring to our humbug budget, have been before alluded to, and it is very often the case that we will receive from widely separated parts of the country, a number of reports of a similar character, all written within a few days of one another. This month the prevailing trouble comes from the doings of

TREE PEDDLERS OR NURSERY AGENTS,

and though we have often warned our readers against these fellows, it is necessary in this, as in other cases, to reiterate. One of the most astonishing things that falls under our observation, is the shortness of memory which prevails. In the budget now before us, we have a letter complaining of a "puzzle-picture, called the Toll-gate," and others asking about Mulligan and his sewing machines. The "Toll-gate" was shown up in September, and the sewing machines any time the past four months. So with nursery agents, and horticultural quacks of all kinds, we have had so much to say about these, that one would suppose that every reader would be on his guard. The nursery agent matter is a difficult one to handle, from the fact that the nurserymen do not pursue a uniform course. While some do not send out any traveling agents whatever, others, and equally respectable ones, do employ agents. On some accounts a traveling agent, provided he really be an agent, is of use, as there are many who will purchase fruit trees upon ner-

sonal application, who would not otherwise do so, and no doubt there is much more fruit grown through their influence, than there would otherwise have been. Could the matter stop here, no one would complain; but agents of this kind are the exception, while those of quite another kind are the rule—and this other kind are a set of liars and swindlers. The outfit required by one of these "agents," is principally an unbounded supply of brass, a glib tongue, an impossibility to understand what the word "no" means, and a power of holding on until the customer is thoroughly tired out, and orders something, to get rid of the chap. In addition to these personal qualifications, he needs a book of colored plates, in which fruits are caricatured as to size and color, and perhaps some bottles containing large currants and other fruits in spirits. This agent goes around in summer for orders to be delivered in fall, and in winter for those to be delivered in spring. When it is near time to deliver his goods, he goes to the large nursery centers, and buys up the refuse stock, such as no respectable establishment would send to its regular customers; all the poorly grown, badly shaped, and "hospital stock" is bought up, and either labeled and assorted there, or sent in a lump to some point central to his customers, there to be used in filling his orders. Of course, the labels on the trees will agree with the names on the order, but that they shall have any reference to the kind of the tree, is of but little consequence. The fraud can not be found out for several years, and the dealer will then be far enough away. All this is bad enough, but these swindlers offer, with vivid descriptions, things which really have no existence, or represent old and worthless varieties as something rare. Of late we have heard much of the selling of the Bush Alpine Strawberry, a new kind, in which the strawberries grow on bushes, and the plants have no runners. The Bush Alpines are among the oldest of strawberries, and there is no bush about them, but their flower-stalks stand erect, while the fruit is to most persons very indifferent. This plant, over two centuries in cultivation, has been sold all over the country the past season as a novelty, and at high prices. One chap has been in Missouri, and other Western States, taking orders for "self-pruning" grape vines; another has gooseberries that are "never sour"—and ornamental peaches "in clusters," giving the purchaser to think it is the fruit that is in clusters, and not informing him, that if an ornamental peach tree should produce fruit at all, it would be worthless. If people would take the trouble to inform themselves about such matters, they could not be imposed upon. It is beyond our comprehension, that any one can be found to believe in such absurdities, as "self-pruning" grape vines—why not self-planting as well? Our advice is, as it always has been, not to buy of agents at all. Send to some respectable nursery (see our advertising columns) for a catalogue, select mainly such fruits as you know, or can learn, to have succeeded in your locality, add such kinds as you would like to try, and send the order direct to the nursery. The freight on a single lot will be a little more in proportion, than on the agent's larger lot, but the certainty of having the kinds that were ordered, more than offsets this. But if one from circumstances must buy from agents, have nothing to do with any one who can not show a recent certificate from a well-known nursery. It is a dodge that agents guarantee to deliver trees from such or such a nursery—but that is no certificate. If any agent or tree peddler offers any unusual novelty—something out of the ordinary way that no one else has, or that has only just been introduced—have nothing to do with him. Such things do not get into the hands of peddlers. Every novelty in fruits and flowers worth having, gets talked of and described in the papers long before it becomes common enough to be sold by these fellows.

SUSPICIOUS SMALL FRUIT DOINGS.

Complaints come to us in regard to one Ohio Small Fruit dealer, whose name is Norris, and these, together with what we can learn from those who know the man and his operations, lead us to advise our readers to be cautious in their dealings with Ohio small fruit farmers of the above name who make a tremendous show with highly ornamental letter heads.

A NICE LITTLE DODGE FOR GETTING NAMES.

Many good people who receive circulars of quack medicines and other things, wonder how the senders could have obtained their names. We have in former numbers explained some of the means resorted to, and stated that lists of addresses were bought and sold like other merchandise. A circular is being forwarded to the officers of various temperance lodges and other associations; it is printed on the back of two specimen pages of a *Temperance Almanac*, which the signers say they are getting up; it asks for statistics about the lodge, its officers, etc., etc., and then adds: "also please send us the names and address of all the members of your lodge, if you have them in print, and if not in print, please give us the names of one or more officers or

members, who would arrange with us to get them up and send them to us." Now this may all be legitimate, and there may be a temperance almanac on foot, but the funny thing about it is, that one of the "specimen pages" is the exact reproduction of a page in a Bitters' man's pamphlet, and the circular is signed with name and number in New York, while the Bitters' thing is signed with another name but at the same number! It all looks very much like a dodge to get names for the Bitters' establishment.

WAR CLAIM SWINDLE.

One of our correspondents in Louisiana, writes that one Capt. Hawk, is going about representing that the Government had made an appropriation to pay the Southerners for property lost during the war, and that he would collect the claims on shares; but as a "condition precedent," he asks each planter for a fee of \$2. "In the vicinity of our town he collected over \$500." Poor chickens of planters, you will know a Hawk the next time you see him!

ANOTHER HARD CASE

is brought to our notice by a lady who sent money to a dealer in Chambersburg, Pa., for eggs, which among other things he advertises. The lady received no eggs, and can neither get her money back nor any reply to her letters. That the man received the money, is shown by the return of the check endorsed by him. It is just one of those cases in which there may be an explanation possible, and all we can do under the circumstances, is to advise the lady to enter a suit for obtaining money under false pretenses.

AND NOW IT IS TOPEKA, KANSAS,

that has a lottery. She does not go for a library like Kentucky, nor yet for a school house, like Nebraska, but for what we always have with us—the poor. It is a grand scheme, \$65,000 of tickets are to be sold, \$55,000 of "gifts" are to be distributed, and if all goes lovely, the poor of Topeka will get \$10,000, and the disinterested Mr. Haywood, who goes through all the trouble, gets nothing—Stop though, \$20,000 of the prizes are in furniture, and it looks very much as if here was a dodge for closing out a slow stock of bedsteads, rocking-chairs, washstands, and the like. Here is an out and out lottery sanctioned by the mayor, all for the chance of getting at the most \$10,000 for the poor! Isn't this selling the moral status of Topeka at a rather cheap rate? . . . It has long passed into a proverb, that there is no

ROYAL ROAD TO LEARNING,

but there is, or very soon will be, for a man in Philadelphia is grading and fixing it up generally, and it is all to be in a book of 100 pages. It is to be called the "Royal Road to Learning, or The Finger-Post to Knowledge." Now how a thing can be both a "road" and a "finger-post" at the same time, seems to us as a little mixed, and would, we believe, puzzle a Philadelphia lawyer. About this road we learn that its size is to be "8x10 inches," but for the rest it is all a muddle. We learn that "disavowing the present brain dulling memorizing of words and lessons, together with ideas, thoughts, and other knowledge, where, in the attempt to grasp the perplexing shadows, the substance is too often lost," yes, "jess so."

COUNTERFEIT MONEY.

After a dreary repetition of the old circulars that were sent out under scores of different names, it is a change to turn to the spick span new one, all in handsome script in the blackest of lithographic ink. And there is no nonsense about it. It offers counterfeit money right out, in lots to suit customers. The circular is not signed, but Mr. Henry C. Bolds encloses his little card—Parties must not call at the address given, as business is only done by appointment. Of course these fellows catch some victims, or the game could not be kept up so long. It is within the power of the police to break the whole thing up in a short time. Only a few days ago Davis & Rowland were arrested, but the detective who personated the stranger from Toronto, was suspected before the rogues had fairly committed themselves. Still it is something to know that they were "locked up for examination." . . . That some

REAL ESTATE AGENTS

are perfectly square business men, we have no doubt, but there are others with whom we should not like to do business. Some letters before us have a very suspicious look. One G. H., of New York, advertised in Maryland and Illinois papers, that he wished to buy a farm. One person in each of the above States, who replied to these advertisements, received each a letter, not from G. H., but from a New York concern calling themselves "real estate agents," informing that G. H. had suited himself to a farm, and turned the letters over to them, the agents. These two letters, one to a man in Maryland, and the other to one in Illinois, are before us, and are, taken together, very interesting reading. The agents write

to the Marylander: "There are two Englishmen, (brothers), *** near Whitestone, Long Island, who desire just such a farm as you describe."—and to the Illinoisian they write: "There are two men, father and son, near Whitestone, Long Island, *** who desire just such a farm as you describe." A remarkable coincidence truly! and Whitestone must be in danger of being depopulated, but the coincidence is not so strange as the correspondence between the two letters, which for four pages of commercial note, are precisely the same, except such trivial verbal differences that one would make in copying. Both pairs of intended purchasers are "willing to pay half cash;" in the Maryland case, the parties are going to view a farm near Lynchburg, Va., and in the Illinois case, they are going to view a farm in Madison, Wis., and (by another coincidence) both pairs of Whitestoners are to start on the 9th of October. In both cases the pairs of Whitestoners are to be persuaded to stop over and see the farms in Maryland and Illinois, and in each case those having the farms to sell, are informed that "these parties mean business," and moreover in both cases "They are of the liberal class, and easily influenced by good treatment." Each man with the farm to sell, is given to understand that these Whitestoners are quite sure to buy. But, for the trouble of getting the Whitestoners "the proper tickets for them, and to see that they go through, and stop at no place this side of yours," these "agents" want \$5 in a registered letter. Of course, if a sale is made, the agents expect a commission, but the \$5 must come anyhow. It is just possible that such a transaction as this is all square, but to our notion, the chance of such a coincidence is about equal to that of these "agents" being struck by lightning. Moral.—Don't invest your \$5 unless you are sure you will get something for it.

Sometimes the literature of quackery is simply disgusting, and one feels ashamed, when he reads the transparent lies, which are told about the discovery of these wonderful nostrums, and the absurd claims made for them, to think there can be found persons so simple and gullible, as to place any confidence in such trash. But there is a still worse feature very common in the quack pamphlets and circulars, their

IMPIETY AND NEAR APPROACH TO BLASPHEMY.

We do not now refer so much to those fellows, who assume the garb of religion as a help to sell their stuff, but to the light and impious ways, in which the name of the Supreme is used, and the manner in which those things, which the better part of mankind hold as sacred, are made to advertise a nostrum. One before us has for its head-line in large letters: "Behold what hath God wrought"—to call attention to a ridiculous yarn about some woman's adventures in Chili in discovering the wonderful herb—which of course grows "only upon a single ridge of mountains." Then she, or he, or whoever it may be, wickedly and uselessly says, "I will stake my existence," that for certain named troubles the stuff is the best remedy known. While these things are vulgarly impious, the circular from which they are taken is not so bad, as that of one who calls himself Dr. Blood. Last month we mentioned the great prevalence of quacks in the generally estimable city of Providence, and a friend there has taken the trouble to send us specimens of the literature that circulates in that place. This Blood sends out a large, four-page sheet, with the cheerful title in large black letters of "Life or Death;" beneath this there are two American flags, which he has had the impudence to besmirch by printing his sanguineous name upon them. At one corner is a picture of what is apparently the Virgin, as *Mater Dolorosa*, with over it the legend "Why will you die?"—and at the opposite corner the head of Christ, crowned with thorns, with a face expressive of great agony. Now we claim that it is absolutely impious to use sacred emblems to advertise one's business of any kind. It would be just as proper for an apple-woman to put up a cross to call attention to her wares, as it is for this Blood to use the image of the Saviour in his suffering to embellish his quack-sheet. With such gross impropriety at the heading, we are not surprised to read beneath, that "where oxygenized air has failed to relieve a patient, nothing but the interposition of Heaven could save him." In another column we learn that Louis Napoleon, Wm. H. Seward, and Horace Greeley might all have been living, but for the doctors, and of Greeley, it is said: "May his soul rest in heaven, where allopathic doctors and hot irons are unknown." It is the duty of every parent to see that such wickedly repulsive literature as this is kept out of the family—not only upon sanitary grounds, but upon moral ones. Children hear an abundance of wickedness, but they should not be allowed to see the names of God and Christ in print, unless mentioned with reverence and affection.

Pure Salt.—"A Dairyman." The Ashton Salt, as imported, is not to be trusted implicitly, as there are said to be four or five different manufacturers who

send salt of this brand to this country. The Onondaga (N. Y.) "factory filled" Salt, is the purest article now made anywhere, and may be relied upon for dairy purposes. Chemical analyses prove it to have less salts of lime, magnesia, or water, than the best Ashton salt, and to have 98.28 per cent of pure salt (chloride of sodium) in its composition, while Ashton salt has but 97.65. At the Central New York Fair, butter packed two years ago with Onondaga salt, was exhibited in good order. Thus the prejudice against American salt, and in favor of the foreign article, is seen to be groundless.

Potash in Compost.—"P. D. H.," Gansvoort, N. H. It would not pay to purchase carbonate of potash for mixing in compost heaps, at \$8 per 100 pounds, which is the market price. It would also require to be ground or dissolved, as it comes in the barrels in large masses, and could not be conveniently used otherwise. The German potash salts (Kainit), which are sold by Geo. E. White, 160 Front St., New York, at about \$30 per ton, would be more economical, and they can be sown by a machine. These salts contain 30 per cent of sulphate of potash, and 16 per cent of sulphate of magnesia. Sulphate of potash yielding 90 per cent, is sold by the same party for 4½ cents per pound.

Castings for Implements.—"Dealer," Rockford, Ill. Castings for agricultural implements, or for light machinery of all kinds, may be procured of Livingstone & Co., Pittsburg, who make a specialty of this business. It would be as well for you to communicate with them.

The American Garden is the title of a new horticultural paper, or rather of a journal that has been essentially changed. Messrs. Beach, Son & Co., seedsmen of Brooklyn, N. Y., for the past two or three years issued a quarterly, which was partly journal and partly catalogue. In September last this was placed in the editorial charge of Mr. James Hogg, and it is now a handsome monthly of 24 pages, somewhat smaller than our own. In its first number of its present form, the Garden saw fit to express itself in regard to the agricultural press in a manner quite uncalled for, and not at all calculated to insure it a favorable reception among agricultural journals, and it chose the Country Gentleman especially, to illustrate the fact, that the agricultural press is given to blundering in floricultural matters. The Country Gentleman of course makes a sharp reply, and an exceedingly neat rebuke was administered to the Garden by the Gardeners' Monthly, which, in its October number, without comment, quotes from the Country Gentleman over half a dozen columns of useful horticultural items. However, we are not disposed to quarrel with the Garden for having made a blunder, and need only say in regard to it, that its editor is abundantly able to make an interesting and useful paper, as he has had a long horticultural experience, and is an easy and pleasant writer. So we give the new journal a welcome, with the remark, that if it chooses to place itself in antagonism with its neighbors, it will find that the agricultural journals will accept the situation.

Book on Diseases of the Horse.—E. H. M., Delaware Co., N. Y. Youatt & Spooner on the Horse, is a useful hook to consult in the absence of a veterinary surgeon. Price, \$1.50.

Deterioration of Sheep.—"L. M. O.," Woodstock, N. H. It is a matter of difficulty, if not of impossibility, to preserve a breed or class of sheep up to its original standard, if the conditions under which it is kept are not suitable. Heavy bodied sheep will persist in becoming leggy and light when bred for a time upon hilly pastures, and if the flock is reinforced by new blood the improvement is only temporary. No breed of sheep can remain in successful or profitable possession of any district, unless the peculiar local conditions as to pasture, climate, and nature of the ground, are found to be exactly fitted for it. It is the inevitable results of such conditions that have produced the wide differences which exist between the various breeds of sheep.

Exports and Imports.—By the latest monthly report from the Bureau of Statistics, we find that the total value of the exports during the fiscal year 1874, exceeded that of the imports by over 39 million dollars; in 1873 the imports exceeded the exports by over 101 million dollars. The balance in favor of the present year, is therefore over 140 million of dollars, and is made up of an increase of exports over 1873, of over 64 million dollars, and a decrease of imports of over 76 millions.

Sweep or Tread-Power.—"R. J. H.," Bedford, Ohio. With a well made tread-power the whole useful effect of the horses is secured. This is not done with the best of the sweep-powers. When heavy horses are used in the tread-power, their weight is usefully applied, but in the sweep there is often no advantage in using heavy horses as against light ones. There is a great economy of space also in using tread-powers. There need be little fear of danger from their use; we have used a tread-power for many years without any accident or approach to one, and have not yet heard of any accident with one.

Field, Cover, and Trap Shooting. by Adam H. Bogardus, and published by J. B. Ford & Co. The author of this work is known as the "champion wing shot of America." This work shows great experience, close observation, and a happy manner of relating adventure and imparting instruction. It is a most interesting book, and one likely to be welcomed by sportsmen. Sent from this office, post-paid, for \$2.

Choice Receipts, by M. S. W., is the title of a work just from the press of J. R. Osgood & Co., Boston. It is a perfect gem in the way of book making, being neat and tasteful to the degree that makes one feel sure that the dishes for which it gives directions must be as good as the manner of presenting them is elegant. This is not a cook-book, but a collection of choice recipes in the different culinary departments, accompanied by concise directions for compounding them. While all else is so complete, it is a wonder that "receipts" should be chosen for the title, instead of *recipes*. There is but one way to test the value of works of this kind, which is to put them to frequent use, and just what we propose to do with this one. Price \$1.50.

Some Species and Varieties of the Lily, is the title of a pamphlet in French, of 35 pages and several illustrations, by J. H. Krelage, Haarlem. A second part is to appear. This work shows that the author, besides being one of the great bulb growers of the world, may claim a high rank as a horticultural writer.

Sore Eyes in Pigs.—"Reader." Inflammation of the eyes, from which pigs are seriously suffering in some parts of the West, is only a symptom of a disease which is known as apoplexy. It is a blood disease, closely related to cholera, and causes an excessive congestion of all the membranes of the head, which is shown in their inflamed condition. There are some other symptoms, very similar to those of "black quarter" in cattle, viz.: black soft patches in various parts of the body, just beneath the skin. The best treatment is to give a strong dose of salts at the first appearance of restlessness and redness of the eyes, and put the animals upon low cooling diet. The cause is want of pure water and too sudden over-feeding, or feeding with unripe corn.

Eight Toes upon one Foot.—"G. H.," Clinton Co., Ohio, sends us a foot of a chicken, which has eight toes upon it. It was very nearly a case of a three-footed chicken, as the line of juncture of two legs is very apparent, and there are two distinct leg-bones.

Sheep Fence.—"G. B.," Coos Co., Oregon. To have a secure fence for sheep it ought to be at least four feet high. If made of boards, the lowest one should be 6 inches from the ground, the second 6 inches from the first board, the third 9 inches from the second, and the fourth 10 inches from the third. This will give 31 inches of space and 24 inches of boards, in all 55 inches, which would be safe for any but very breachy sheep.

Canvass Roofing.—"F. G.," Herkimer Co., N. Y. The chief fault of canvass roofing is its cost. It makes a tight, durable roof, if kept well painted. The roofing felt made by Fay & Co., Camden, N. J., is much cheaper and is as tight and durable as canvass.

Aphtha in Cattle.—"S. A.," Moosup, Conn. This disease, much more serious than that known as foot-rot, is often taken for it, because the foot is first affected. It is an eruptive fever, which occurs but once in the life of an animal. It affects first the feet, and generally the off or right hind foot is first attacked. Small blisters form between the claws and around the coronet of the hoof, causing great pain, and the animal holds the affected foot backwards and shakes it, or lies down, and is disinclined to rise. If the mouth is now examined, the tongue, lips, and inside of the jaws, are found inflamed in patches, and small blisters as large as a pea appear. By and by these, as well as those on the feet, burst and run together, forming raw surfaces, which are very sensitive and painful. The hoofs often slough entirely away. In a few days the raw surfaces are covered with scabs, the fever is lessened, and from the tenth to

the fifteenth day the disease abates. It is highly contagious, and fresh animals introduced into the farm or stables where it has prevailed, are taken down rapidly. The treatment recommended is a purgative of 8 ounces of Epsom salts mixed with 2 ounces of gentian root powdered, and $\frac{1}{2}$ a pint of molasses. This is placed upon the tongue in portions, until it is all swallowed. The feet are poulticed with linseed meal, or fomented with hot water, until the blisters are broken and suppuration occurs. They are then dressed with a pint of water, in which 2 drams of chloride of zinc and 1 ounce tincture of myrrh has been dissolved. The food of the animal should be mashes of barley malt, with some linseed meal, or boiled oats, green clover, or chopped carrots, and generally cooling laxative feed and demulcent drinks, as linseed or oat meal gruel. It is well to procure professional assistance if possible. The stables should also be thoroughly cleaned, disinfected, and whitewashed.

Pasturing Sheep.—"G. B.," Coos Co., Oregon. A newly seeded pasture should not be used until the grass has become well rooted. It may be mown once before sheep are turned upon it. A year's growth at least should be allowed before the grass is pastured. Sheep will not eat ferns.

Brick Machine.—"E. O. M.," Tracy City, Tenn. An excellent brick machine that can be worked with two horses and three men, is made by R. H. Allen & Co., of 189 Water-st., New York. It costs \$450, and will mix clay, and make 25,000 bricks per day. A machine to make tiles can be procured for \$325.

Cheap Food for Store Hogs.—"D. L. Z.," Rolla, Mo. Corn is neither economical nor wholesome food for store hogs. A small portion of corn ought to be fed; but the greater bulk of the food may be made up of boiled potatoes, cut clover, hay and corn fodder, scalded and sprinkled over with wheat or rye bran, and slightly salted, mixed together and fed cold. We have fed store hogs upon this food throughout the winter, and kept them in growing thrifty condition at very little expense. The clover and corn fodder is eaten readily along with the potatoes and bran. For drink we gave a thin slop of corn meal and bran, which was allowed to ferment and sour slightly.

Floating Curds.—"A Dairyman," Utica, N. Y. The cause of floating curds is much disputed. Probably few dairymen, who profess to have studied the matter, agree upon any one thing as the true cause, and many allege widely different reasons for it. The cause has been variously said to be in the cow, in her food, in the water she drinks, in the air she breathes, in the fullness of the stables, in the care of the milk, in the condition of the dairy utensils, in the condition of the air; electricity has been blamed for it, as has that very handy and useful, but indefinite cause called "germs in the air." It is easier to say what is not the cause than what is. It is still a matter for close investigation.

Shipment of Bone-Dust.—A 500 ton vessel has recently cleared from Chicago for Liverpool, loaded with bone-dust. The sending off of this indispensable fertilizer from our own fields is to be regretted, the more so when we consider that the Illinois prairies are already falling off in their produce of grain, and can hardly spare the loss of the bone which represents their past fertility.

Preservation of Manure.—Investigations have been made by Professor Way, of England, by which the increased value of manure kept under shelter is accurately determined as against that exposed in open yards. The following are the relative values as determined by analyses of the dry manures, the water being nearly equal in each, and about 71 per cent:

	Covered Manure.	Yard Manure.
Nitrogen, equal to ammonia, per cent.	2.37	1.7
Organic matter, soluble in water.	6.42	1.82
Phosphoric acid.	.30	.26
Alkalies.	2.00	.50

The other constituents, not being of importance, were not determined. The value of the covered manure is seen to be more than double that of the other.

Beef Clubs.—"A Beef-eater," Akron, Ohio. The difficulty in the way of farmers procuring a regular supply of fresh beef or mutton might easily be removed by forming beef clubs, as is done in Tennessee. One of these clubs has been in operation 20 years. There are 16 members. Each member provides a three-year-old steer, or a cow, and feeds the animal so that it shall be ready for the butcher at a stated time. Each member's time is fixed at a meeting for that purpose. Each animal is to be of such a quality that there shall be 12 $\frac{1}{2}$ per cent of

tallow to the meat, or a fine of \$5 is levied. The best beef draws a premium of \$10. A butcher is selected in some central locality, who slaughters an animal every Saturday and divides it into sixteen portions of equal value. He keeps a correct account of each animal, credits the owner with the proceeds, and charges each member with his share. At the end of the term a settlement is made, and those who are in debt pay the amounts, which are then paid over to those who have a credit. Of course the debts exactly balance the credits on the whole. Each member gets about 25 pounds of beef every week. If it is desirable, the club might consist of 26 members, and each one might provide a beef twice a year. This would give a constant supply. Then, if the dogs were looked after and a dozen sheep kept on every farm, there would be plenty of lamb and mutton.

A Perfect Harrow.—"L. D. N.," Annapolis, Md. We know of no perfect harrow, that is one that will do all the various kinds of work that harrows are expected to do. There are some implements that are better than others for certain uses. Thus the Thomas' Harrow is unique for light work, such as grass seeding, or for destroying weeds, while the Nishwitz or the Shares' Harrow will cover sod or mellow the soil better than any others we know of, unless perhaps it be one recently brought to our notice, known as the "Wheel Harrow," which, in addition to the excellent form of the teeth, can be raised or depressed, and which has some other advantages. A farmer that has various kinds of work to do, needs more than one harrow, and if he has a good roller, there are many uses for which it may be usefully made to supersede the harrow. By and by we believe the ordinary harrow, as we know it, will be displaced by much more acceptable implements, such as the grubber and the various surface cultivators. The day of the old-fashioned square-toothed harrow is about over.

Salsify, When and How to Use.—"G. P." Salsify, or, as it is often called, Oyster Plant, may be used whenever the root is large enough, but as it is never much over an inch in diameter, those who sell it usually let it grow as large as possible. Whichever way it is cooked, the first step is to scrape it to remove the skin, and throw each root into water as soon as scraped, to prevent it from turning a dark color. It may be cut into inch pieces and stewed tender, adding milk, butter, and a little flour, to make a sauce. It may also be fried; one way is to cut the root into convenient pieces, boil until tender; dip in batter and fry like fritters; another, boil tender, mash, and make into balls, which are floured and then fried brown. The writer, who has it two or three times a week during the winter, has it cooked by stewing almost exclusively.

Trout in Hard Water.—"Badger," Berlin, Wisconsin. Trout will thrive excellently in hard water, if the hardness is due only to carbonate of lime. Some of the best trout streams run through a limestone country. Clear cold rapid running water, free from any other mineral impurity than lime, is well adapted for these fish. Washings from lead or copper mines, the refuse from dye works, or woolen mills, or sawdust from saw mills, in excessive quantities, will kill or drive away trout. The drawing of wagon-jack is received.

Carbolic Acid in the Dairy.—"A. E. R.," Jefferson Co., W. Va. There is nothing that absorbs strong odors more readily than cream. If so strong a smelling substance as carbolic acid is used in a milk cellar, it would certainly spoil the cream, and the churn would absorb some of the odor if the cream was churned in it. Probably the best way to purify the churn in such a case, would be to put it in a running stream for a few days, or until the scent disappears.

Salt upon Wheat.—"Reader," Clyde, Ohio. Salt being very soluble should only be applied to wheat in the spring, when it can be appropriated by the plant. It is generally used in quantities of two to four bushels per acre, to stiffen the straw.

Compost Heaps.—"A. J. M.," Hollansburgh, Ohio. Compost heaps are made by mixing a portion of fresh stable manure with vegetable or animal matter, which by itself would not readily decompose. The substances used are placed in layers in a close compact pile, made flat on the top so as to catch enough rain to keep it moist. The manure sets the whole in a fermenting condition, and it quickly decomposes. It frequently occurs that the pile must be taken down, turned over, and piled up again for a second fermentation, before it becomes well rotted. "Dommer's art of making manure," describes an excellent method of making composts. It costs 25 cents. Patent expired.

See Page 433.

Noise in a Horse's Abdomen.—"F. A. G.," Stirling, Ill. The unpleasant noise referred to is frequently caused by an accumulation of wind or gas in the bowels. Some horses are subject to chronic flatulence on account of indigestion. A remedy might be sought in feeding moist food with bran mashes, or some linseed meal, so as to keep the bowels somewhat loose, adding half an ounce of salt to each feed, and giving a dram of copperas with one ounce of ginger at night, for a week or two. It is often incurable.

Lands in Eastern Virginia.—"C. F. S.," Guernsey Co., Ohio, may communicate with Chaffin, Staples & Co., of Richmond, Va.

The Preparation of Plaster.—"W. W. S.," Hallock, Ill. It is very probable that plaster would act favorably upon clover in your soil. We have known it to be used with success in most of the Western and Northern States. The rock plaster can be purchased cheaply at Saginaw or Grand Rapids, Mich., and in Syracuse, N. Y. The freight from either place in bulk would not make it too costly for use. It should not be hurried before being ground, nor should any plaster be purchased that contains any impurity whatever. It can be ground, after having been broken into small pieces, between common burr-stones, such as are used in a grist-mill. There is a great deal of ignorance as to the use and nature of plaster where it is not much known. It is not lime, nor does it possess any of the caustic or other qualities of ordinary lime, but is a perfectly distinct compound of lime, sulphuric acid, and water.

Ditching Machine.—"E. M.," Santee, S. C. The Carter Ditching Machine, to which we have referred, would not answer the purpose of clearing out the ditches of rice plantations. It would not be difficult, however, to construct a machine to be drawn by mules, which would clear out the growth of weeds and the accumulated mud, and deposit them upon the bank, if it should be found cheaper to do the work in that manner than by hand labor. It is a question of cost altogether.

As to Pigeons.—"E. M.," Santee, S. C. The common domestic pigeon would probably be as profitable to raise as any. A loft over a poultry house would answer very well for the roost and nests, but it should be kept perfectly clean. Peas are favorite food for these birds, as many a gardener knows to his cost, barley or oats may also be fed to them.

Cultivation of Barley.—"C. J.," Roanoke Co., Va. It is better to make barley a spring crop. If fall wheat happens to be a failure, the ground may be replowed and sown to barley very conveniently and profitably. There is no better crop than this with which to seed down to clover or timothy. Barley is imported from Europe to supply our markets, and this fact would imply that its culture ought to be profitable. As feed a good crop of barley is more profitable than oats, and there is no grain better for horses, pigs, and poultry. It thrives better under heat than oats, but must have a good soil and clean tillage. If you have these, we know of no reason why you may not grow this crop with profit. If you can raise 20 bushels of wheat per acre, you ought to produce 40 bushels of barley.

Guano for Grass.—"H. C. C.," Gardiner, Me. A usual dressing of guano for grass is 250 pounds per acre. It depends, however, upon the nature of the soil whether two tons of hay per acre can be grown yearly. We have known the above quantity of guano to double the crop of grass, but in a dry season we have known it to fail of effect entirely.

Stable for a Colt.—"J. H. B.," Watertown, Ct. We would prefer to keep a colt or a horse in what is called a loose box, rather than in a narrow stall, and tied up. There is always some danger when a horse is tied in a stall, but none in a properly constructed loose box. The box should be 12 feet square, with walls 6 feet high; the feed trough should be made to swing outside of the box into the feed passage, so that there is nothing inside that could cause any accident whatever. A valuable horse is thus safe from accident, and the extra cost of such a stable is repaid in many ways.

Cheese Press.—"E. F. P.," Anderson Co., Texas. In the *Agriculturist* of April, 1874, will be found an engraving of a cheese press, which any mechanic can make, and metallic hoops. The power may be applied by means of a lever, or the screw may be procured of Millar & Co., Utica, N. Y.

South Carolina Phosphates.—There are 18 companies engaged in mining phosphate rock in South Carolina. The produce last year was 112,515 tons,

of which 18,000 were used in manufacturing fertilizers in Charleston, 41,975 tons were shipped to Northern ports, and 52,730 tons were shipped to Europe.

Scalding Feed.—"A. B.," Hancock, N. H. —It would be very advisable during the winter months to cut the hay or fodder fed to cows, and after mixing the meal, or shorts, to be fed with it, to scald the whole with boiling water in a feed box or barrel. It should be covered closely with a lid or thick cloth, and allowed to cool down to a moderate warmth before feeding it. If the feed for 10 or 12 head is thus prepared, a 10-hushel box or chest would be large enough to scald the feed in, and that quantity of feed, closely covered, would take 12 hours to cool down sufficiently to be fed. More feed thus prepared would be eaten than of dry feed, and it would be more digestible. Each cow should have at each feed a bushel of cut hay with one quart of meal, and half an ounce of salt.

The Dairy in Colorado.—"W. W. L.," Rockford, Ill. There are numerous grassy valleys in the mountains of Colorado, where dairying may be carried on successfully. These are too small for stock-raising purposes, and are therefore free from interference from stock men. The water is cool and pure, and it is doubtful if there are any better locations for co-operative butter or cheese factories, than these retired valleys.

Half-bred Colts.—"W. M. S.," Ashleyville, Mass. No half-thoroughbred colt that is of any value, could be bought for \$75. The fee for the services of a good stallion is often \$50 to \$100, and the service of very few real thoroughbreds could be had for those prices. The value of any good colt, four or five months old, of common stock, ought to be \$75. It would therefore be labor lost in seeking a half-thoroughbred for that price.

Abandoned Farms in the East.—"T. E. L.," Wilmington, Del. The statement that large portions of the New England States are depopulated, and farms abandoned by hundreds, is too absurd to need a denial. No person should suppose that any farm is abandoned by its owners, or that any land is thrown out of cultivation, where farm products bear the price they do in New England. These abandoned farms and houses exist only in imagination. There is a large portion of New England that is fit only for pasture, and we have seen hill-farms that persons used to level, smooth land, would consider of little value, that on the contrary are profitable dairy farms and worth \$100 an acre for pasture alone. If any person wants to buy a good farm, in a good locality, in New England, he would have to pay at least \$100 to \$200 per acre. Sheep farming, however, can not be made profitable as a special business on the small farms common in New England, and there is no such wide range to be had there, as in some parts of the West.

Reclamation and Protection of Land.—This is the title of a small work, by David Stevenson, Vice-President of the Royal Society of Engineers, descriptive of the methods of embanking tidal rivers, for the purpose of reclaiming marsh or overflowed land, which have been adopted successfully in Scotland. By the system described no less than 7000 acres of land have been reclaimed on the banks of the river Dee. Considering the vast field which is presented to us in our tidal rivers and estuaries, for both improving navigation, and making valuable land, this book will be found of great interest and value. Published by A. & C. Black, Edinburgh.

New Market for Grain.—A cargo of oats, and one of wheat, have been recently shipped from San Francisco to Callao, Peru. A cargo of barley has also been shipped to Iquiqui, in the same country. These cargoes are the first that have been shipped to these ports from California, and mark the opening of a new trade in grain.

Failure to Breed.—"J. N. P.," Sharon, Pa. Ground rye has no injurious effect upon the breeding of a mare, any more than other grain, unless it is fed in excess, so that the mare is kept in too high condition. If the condition is too high, the mare may be reduced by bleeding, or by extra work with a reduction of feed. Bleeding and turning the mare to grass with the horse, is often resorted to in such a case as this, but the shoes should be removed for fear of injury by kicking.

Bog and Blood Spavin.—"H. E. H.," Brownsville, Pa. In 1873 we said "hog and blood-spavin are two different things, although they often exist together. Bog-spavin rarely causes lameness, but is frequently incurable." You have not quoted this correctly. Blood-spavin is an aggravated form of hog-spavin, and is an unsoundness in a horse, while bog-spavin is not an

unsoundness, unless it interferes with the action of the joint, which it rarely does. Windgalls rarely cause lameness, and are not of themselves an unsoundness. These hemishes are often hereditary, but are generally the effect of hard work, and in this case, if cured, will appear again upon the first return of the original cause.

Lands in Nebraska.—For the benefit of several enquirers, we would say that the lands belonging to the Union Pacific and Burlington and Missouri railroads in Nebraska, are situated in the valleys of the Platte and its tributaries. These lands are as rich as any in the West, and the climate is exceedingly healthful. Spring wheat, flax, oats, and corn, are the chief grain crops raised on the newly broken prairie. The lands are sold at low prices and on easy terms of payment, and the country is settling very rapidly. There is no State in which agriculture is more liberally fostered by the government, than in Nebraska. The only want is timber, but timber may be much more easily and quickly grown upon a prairie farm, than a farm can be cleared out of timber lands.

Salt as a Fertilizer.—"A. F. R.," Newark, Ohio. Salt being readily soluble, should be sown upon wheat at that period when it can be appropriated by the plant most usefully. As its effect is in some manner as yet undetermined to stiffen the straw and help the plant to appropriate the necessary silica for this purpose, it should be sown in spring, before the grain commences to ear. Early in April would be a good time to sow it upon this crop, or upon rye. For oats it should be sown when they are six or eight inches high.

Sale of a Jersey Herd.—The herd of Jerseys belonging to I. H. McHenry, of Maryland, were sold at public sale on the 2nd of September. The prices realized were very low, varying from \$17 up to \$405. H. C. Kelsey, of Trenton, N. J.; W. E. Dougherty, of Harrisburg, Pa.; and Col. F. D. Curtis, of Kirby Homestead, Charlton, N. Y., were the principal purchasers. The highest prices were \$310 for an imported cow, "Gold Drop," over six years old, and \$405 for "Laura," 5 years old, bred by Mr. McHenry.

The Swivel Plow.—"A. R. C.," Ham. Co., Ohio. It depends somewhat upon the soil, whether a swivel plow, as indeed any other plow, will turn a perfect furrow. There are some soils in which no iron plow will turn a perfect furrow, and steel plows must be used. There are no steel swivel plows yet made, and we could hardly say that any iron swivel plow we have yet seen or tried, will do all that is claimed for it in every soil.

Roup in Fowls.—"Old Subscriber," Crescent City, Cal. One of the symptoms of roup is inflammation of the eye with swelling, and discharge of fetid matter. Unless some remedy is applied, the eye is destroyed or the bird dies. A remedy which is generally effective, is to wash the eye, mouth, and nostrils, with a solution of chloride of zinc, one ounce in a pint of water, by means of a feather. The cause is frequently cold, inflammation resulting from feeding too much grain, foul unventilated quarters, or over crowding.

Lands in Iowa.—The settlement of Iowa has progressed so far, that desirable homesteads upon government land, can no longer be procured. It is only in a few of the northwestern counties, that any government lands remain unoccupied. Rather than take these for nothing, a settler had better pay a fair price for lands near a railroad; indeed he will save money by so doing. There are 1,500,000 acres of the best lands in central Iowa, belonging to the Iowa Railroad Land Company, offered for sale at from \$5 to \$7 per acre. This part of the State is well watered, is a good grass, corn, and wheat region, and is only a short distance from Chicago.

The Texas Cattle Trade.—The present year's cattle trade at Topeka, Kansas, is 25 per cent larger than that of last year. In 1873, 118,206 head were handled; in 1874, 155,300 have been handled, and there are 115,000 more in the State to come forward. The whole number shipped and to be shipped from the State the present season is estimated at 500,000, worth 10 millions of dollars. This is but the beginning of the cattle business, which has grown to these proportions since the opening of railroads in Kansas. The demand for these cattle is yearly increasing, and the produce keeps pace with the demand; the immense facilities for raising cheap cattle in the States of Texas, Kansas, and Colorado, being unequalled elsewhere, at the same time the use of improved or pure bred bulls is largely adding to the value of the stock now raised.

Preserving Green Fodder.—"H. L.," Transylvania Co., N. C. The method of preserving green fodder, recently described in the *Agriculturist*, is practiced extensively in Europe, and has been in use for many years. In a recent number of a French agricultural journal there is a statement of a large farmer, who put up in this manner 100 tons of corn fodder in 1871, 200 tons in 1872, and 150 tons in 1873. He used 3 lbs. of salt to the 1,000 lbs. of fodder, half dried. When the fodder is not so dry, more salt is used. It is necessary that the fodder be perfectly free from external moisture, and be also partly dried or wilted: that it be packed very closely; that the covering should be at least 2 feet thick, and prevent access of air, and that the pit be dug in a perfectly dry spot, and be kept free from water. It might be well to try again. We have seen beet leaves taken from such a pit in the spring, which were packed away in the preceding fall, and they were readily eaten by cows and oxen.

See Page 433.

"Walks and Talks" Correspondence.

GRADE ESSEX PIGS.—C. W. Hess, Columbus, O., writes: "I have a fine drove of black pigs, from large Poland-China sows, and a thoroughbred Essex boar. I am well pleased with the stock, and think it is a good cross."—This is precisely what I should expect. Another cross of the Essex on these young half-bred sows will, I think, give still finer pigs. It is only when you resort to the use of cross-bred or grade males that the stock begins to show a want of uniformity.

WHEAT FOR HORSES.—The proprietor of an extensive mail-route in the South-west, where the grasshoppers have destroyed nearly everything, except wheat, writes that he has contracted for 10,000 bushels of wheat, at 50 cents per bushel, to feed his horses. So far they have done well, and the wheat is much cheaper than oats. I suppose the only danger is from the horses eating too much at a time. If it could be soaked in water for four or five hours, it probably would be less likely to swell in the stomach, or produce colic. If ground, and mixed with cut hay, it would be still better, but I suppose this can not be done.

A SMALL FLOCK OF SHEEP.—"A Young Farmer," of Washington Co., N. Y., says he wants to keep a flock of fifteen sheep, and asks, "if Spanish Merinos would not be best to raise full-bloods, or for early lambs for the butcher, and for wool?" I think not. With good care some of the "mutton breeds," such as the South Down, Shropshire Down, Leicester, or Cotswolds, would pay better in such circumstances. On cheap land, where sheep are kept in large flocks principally for wool, the Merino would be the most profitable breed.

THRRESHING WHEAT FROM THE FIELD.—A correspondent in Beaver Co., Pa., writes: "You speak of threshing your wheat as you haul it. How did you get your hands? Did you thresh in the field?"—No. I drew it to the barn, so as to stack the straw where I wanted it. We thresh with a ten-horse machine. The "threshers" charge 5 cents a bushel for wheat, 4 cents for barley, and 3 cents for oats. They furnish the machine, and four horses, and four men." One of the men drives, one feeds, one carries away the grain, and the other oils and looks after the machine, changing occasionally with the feeder. In threshing from a stack, or from a bay, it usually takes 2 men on the stack, and sometimes 3, 1 to cut the bands, 2 on the straw-stack, and sometimes 3=5 men, besides the threshers, and sometimes 7. In drawing and threshing from the field, it takes: 1 man to pitch, 3 men to load, drive, and unload, 1 to cut bands, 2 men on the stack, and sometimes 3=7 men, besides threshers, and sometimes 8. I keep eight farm-horses and four wagons. The Deacon and the Squire exchange work with me, sending a team and a man each. Or, if they have not the time, I get some other neighbor. You see from the above statement, that it takes only two more men to draw in and thresh, than to thresh alone—and sometimes only one man more.

SOWING DIFFERENT VARIETIES OF WHEAT TOGETHER.—"R. G.," Plymouth, O., writes, that the wheat crop of his section has been an extraordinary one. He has heard of no crop less than 20 bushels per acre, and one that was 46 bushels per acre. "The same man," he says, "had 40½ bushels on the same land last year. Last year he mixed three kinds of wheat together for seed. This year he had some five or six kinds. What is your opinion as to the advantage of mixing different varieties of seed together?"—I have seen accounts of large crops being produced in this way. I think, however, if your land is rich enough, and you should select the best one of the wheats,

you would have as good a crop, as if you sowed half a dozen kinds.

THICK AND THIN SEEDING.—"R. G." says: "Farmers here (Ohio) have been in the habit of sowing 1½ bushels of wheat per acre. I am satisfied it is too much, if the ground is in good condition and the seed all sound."—There is one point that should not be overlooked in discussing this question: *Thin sown wheat is apt to be late.* And late wheat is more liable to injury from rust and mildew than that which ripens earlier. If everything is favorable, the late wheat may produce the heavier crop.

SUFFOLK HOGS.—Mr. Isaac Stickney, of Henry Co., Ill., who, when a resident of Massachusetts, was one of the earliest importers and breeders of Suffolk hogs, writes me that he still admires the Suffolks more than any other breed, but that they will not thrive with ordinary usage on the prairies. This is owing to the hot sun and prairie mud, (not wind, as I printed it in the June No.) "In hot weather," Mr. S. remarks, "our hogs get into the wet and muddy sloughs. This mud sticks so tight to the skin of a Suffolk hog, that it is very hard to rub off. It can be washed off. This dry mud frets them so much that they do not thrive well, and it frequently chaps and cracks the skin. Our black hogs with a thick skin, well coated with bristles, are not troubled with the mud."

MOIST FALLOW GROUND.—A farmer writes me that he summer-fallowed a piece of land for wheat this year. His usual practice has been to sow oats and follow them with wheat. "We stirred the land," he writes, "every two weeks alternately with Carhart's two-horse cultivator and Thomas' harrow. We sowed our wheat on the 28th of August, and found the ground in quite good order, and far more dampness than in the oat stubble, which is being plowed to-day" (Sept. 3). This is a well known fact. A growing crop takes large quantities of water from the soil. The roots absorb the moisture from the soil, and the leaves evaporate it into the atmosphere. The frequent stirring of the surface soil would make it fine, and it would act as a mulch and check the evaporation of water from the soil underneath.

SEEDING WITH OATS.—"You say," writes the same correspondent, "that wheat is the best crop to seed down with. We as often hit a good sod with oats as with wheat."—My own seeding this year is better with spring barley than with winter wheat—both being in the same field. I presume more depends on sowing early and having the land fine, mellow, and in good condition, than on the kind of crop.

The New York Flower Auctions.

For several years past the Florists in the vicinity of New York, as well as those from Philadelphia, Baltimore, Albany, and other places, have adopted the method of selling their surplus stock by auction in New York City. These sales are almost exclusively attended by the Trade, as the lots offered are usually too large for amateurs wishing plants for their own use. This season these sales have been held nearly every other day since the first of September, and will probably continue to the end of November.

The articles sold embrace nearly every thing in the way of flowers cultivated in our gardens and green-houses. The prices so far this season have been lower than usual, so low that it would astonish many of our readers to see plants that they cannot purchase for less than 50c. or \$1 each, ruthlessly struck off by the auctioneer at may be \$5 per 100.—But then this hundred is all of one sort, bought by some florist, from a neighbor florist, who happens to be unable to grow the article, or to be out of it. Still many articles bring, even in quantity, their full retail value, and it is a pleasing fact to observe a growing taste for the finer and rarer plants. A few days ago a box of 200 *Tritoma grandiflora*, (red-hot poker plant), was put up, and as some thousands of it had been previously sold, the lot went a begging at \$2 per 100. The next lot was 100 seedlings of *Dracena indivisa*, a rather scarce hot-house plant, bearing, in its weak condition, some resemblance to the *Tritoma*, but the knowing ones quickly detected the value, and the tiny plants of the *Dracena* brought \$25 per 100.

These sales are almost exclusively conducted by Mr. Elliot, of Young & Elliot, the well known seedsmen. Mr. Elliot is not only well gifted with the talents necessary in an auctioneer, but he brings to his assistance the knowledge that a 25-year's experience has given him as a practical horticulturist. The purchasers at these sales are not confined to the vicinity of New York, but come from points, many of them, 100 to 200 miles distant, and it is not unusual to see from 75 to 100 growers and dealers in flowers assembled in the auction room, expecting "bargains" from the hands of the auctioneer. To all interested in plants, the auction room No. 12 Courtland

St., is a most attractive place from 9 A. M. to 4 P. M. During the fall months there is a continuous stream of wagons, loading or unloading plants of every variety, and from every clime.

As there is not an Horticultural Society in New York, Brooklyn, or Jersey City, with their nearly two millions of inhabitants, it is no wonder that many of those who hunger after flowers are attracted by the exhibitions at the Plant Auction Room.

Catalogues, etc., Received.

Since the very full list given last month was made up, the following have come to hand:

NURSERIES.

SAMUEL KINSEY, Dayton, O. Small fruits and ornamental shrubs.

J. & W. K. JUDEFIND, Edesville, Md. The Amazon Raspberry.

MERRELL & COLEMAN, Geneva, N. Y. Special circular of a new early grape, the Whitehall.

WM. H. MOON, Glenwood Nurseries, Morrisville, Pa. A semi-annual trade list.

ROBERT DOTGLAS & SONS, Waukegan, Ill. Wholesale list of their immense stock of evergreen and ornamental tree seedlings.

PHINNEY & Co., Sturgeon Bay, Wis., present their catalogue of forest trees in the form of a journal, called "The Evergreen."

C. L. HOAG, Lockport, N. Y., makes a specialty of grapes and strawberries, and sends his wholesale list.

A. HANCE & SON, Red Bank, N. J. Special circular of Queen Victoria Daisy.

WILLIAM PARRY, Pomona Nursery, Cinnaminson, N. J. This celebrated establishment comes out with a brand new and very full catalogue. Pray, friend Parry, what is the "Carolina Poplar"? We were not aware that any poplar grew there that is not found in the Northern States.

JOHN SAUL, Washington, D. C., whose name is usually associated with floriculture, has also a large nursery stock. Those who doubt it should send for his catalogue.

FLORISTS.

JOSEPH W. VESTAL, Cambridge City, Ind., sends an abridged price list.

MILLER & HAYES, Mount Airy Nurseries, Phila., have a magnificent collection of roses, which they tell about in a special and very handsome catalogue.

MISCELLANEOUS.

A. I. ROOT & Co., Medina, O., have all kinds of apiary requisites, from bees to gather honey to extractors to take it away from them. And more than that, they publish every month a neat little journal, called "Gleanings in Bee-Culture," which tells how to do all sorts of things, to, with, for, and about bees.

ORANGE CO. MILK-PAN COMPANY, which is, of course, made in Delaware Co., N. Y., at Franklin, gives reasons in a catalogue why their pan is superior to others.

W. G. MONK, Brooklyn, N. Y., has an account of his Steatine wares. We have seen his flower-vases, and like their looks.

E. I. HORSMAN, 100 William St., N. Y., sends an immense catalogue of games and toys, prominent among which are the renowned Acrobats.

THOMAS H. SPEAKMAN, Phila., Pa., sets forth the excellencies of his Combination or Prairie Fence.

J. HYDE FISHER, Chicago, Ill., illustrates his refrigerators in a large pamphlet. Fisher is a very cooling chap, and he refrigerates everything, from a family to a railroad car.

EUROPEAN CATALOGUES.

WILLIAM BULL, Kings Road, Chelsea, London, S. W., has a list of bulbs of appalling magnitude.

WILLIAM BRYN & Co., Glasgow and London, send a wholesale price list of vegetable and agricultural seeds.

The State Fairs.—We regret that we have only space sufficient to barely mention the State Fairs, as many of them were deserving of special notice, for the praiseworthy efforts made by their managers to render them attractive and instructive. Amongst those of which we have notes are the New York State Fairs, (the State Fair and the Western N. Y. Fair). These two were held at the same time and at the same locality (Rochester), and it was not at all a difficult matter for persons wanting to go to one fair to find themselves in the other. Probably this competition was one of the reasons why the stock on exhibition at the State Fair was inferior to that shown on previous occasions. The

usual courtesies extended to members of the press were forgotten at this fair. The managers of the Western N. Y. Fair were more thoughtful and enterprising, and from a rapid survey of the grounds, we judge this fair to have been the more successful of the two. The New Jersey State Fair, at Waverly, was unfortunate in having a succession of stormy days, which necessitated a postponement. In all else this fair was a well deserved success, and its ill fortune is to be regretted. The Connecticut State Fair, held at Hartford, was the first agricultural and industrial exhibition of the Connecticut Stock Breeder's Association, and was well attended. The stock on exhibition was very good. One of the side shows here was a fat heifer, 7 years old, said by her owner to weigh 4,000 lbs.; among the horses exhibited was a stallion 18 years old, with 15 of his colts. The other of the State Fairs in New England were sufficiently successful to satisfy their managers and the public. The Pennsylvania State Fair opened at Easton, Sept. 29. Here there was a large collection of stock, of which the horses were very fine. This was a better exhibition than any previous one we have seen in this State. The Illinois State Fair, as usual, had an immense exhibition of stock. The Shorthorns, of course, predominated; the Percheron horses made an attractive show, which was deservedly popular; the hogs, more especially Berkshires and Poland-Chinas, were in great number. The Iowa State Fair opened with nearly 5,000 entries, and was well attended. The Kansas State Fair made a remarkable show, considering the reported devastations of the locust and chinch bugs. Certainly a good deal must have been left, if the collections of products gathered by the various railroad companies were a fair sample. But the Kansas people have long been noted for the cheerful way in which they take their mishaps as they come. At this fair horse-raising and whiskey-selling were prohibited by the Legislature, nevertheless it was the most successful in a pecuniary way of any fair yet held. The pomological display this year was especially good. Nearly all of the above remarks will apply to the Nebraska Fair, which was very similar in character to that of its neighboring State. As a rule, the present year has been remarkable for an increased popularity of the county and local exhibitions, and for a corresponding neglect of the State fairs by the farmers. One could not fail to observe in some cases that the visitors were in great part dwellers in towns and villages, and not farmers. Perhaps this is not to be regretted, for if farmers sustain their county and local fairs well, many of the State fairs might usefully be given to those who will be easily satisfied with a very little of the agricultural and a great deal of every thing else. It is to be hoped that we may sometime see an agricultural fair that is really what its title suggests, and that farmers will be found ready to support and encourage such a fair. Farm stock and implements, farm products, and trials of machinery, with plowing matches, ought to be sufficient of themselves alone to make up an attractive agricultural fair without the aid of the contents of an immense variety-store, which serve to fill the eye for a moment and then are forgotten.

Introducing a "Professor."

LADIES AND GENTLEMEN:—We would introduce to you a "professor."—We know he is a professor, because he signs himself so, and as we shall show, he professeth much. His name it is James N. Bishop, and his dwelling place it is Plainville, Conn. His vocation was a florist, but now he is a "writist."—We became acquainted with "Professor" James N. through the medium of the *Manchester News*. The Editor of the *News* has an article praising the "professor," and in the same column the "professor" has an article praising the *News*. From both these articles we glean that "Prof. B. has retired from the business he so long followed, and consequently having no axe of his own to grind, may be relied upon as the best authority in the matter of horticulture."—See that now—here is a "best authority" who has been in retirement, and has only now come out, to speak horticulturally, in full blow. Then the "professor" says, "we shall aim only at the truth in horticultural discussion"—which he proceeds to do—only the "truth" gets badly hit when James N. "aims" at it—but he "shall seek in this department to record the best obtainable information"—and that is just exactly what he does. His first contribution to enlighten the people of Conn. is on "Soil for Potting Plants," and this "professor" knows just where to go for the "best obtainable information," and finds it too—else what's the use of being a "professor." His information was "best obtainable" in "Practical Floriculture," written by Peter Henderson, and published by the Orange Judd Company. The article in the *Manchester News* for Aug. 8 is, sentence after sentence, quoted word for word from Chapter V. of the work above referred to; a few omissions are made,

such as Mr. H.'s invitation to the public to witness his operations, and a few verbal alterations are here and there, but the article is essentially, in its ideas and language, Peter Henderson's, yet it is signed James N. Bishop. Our publishers might invite the publishers of the *News* and this Bishop into court for violation of copyright, but we have no doubt the *News* was imposed upon by this pretender, and as for the "Professor," it is not likely that any one who would be guilty of the meanness of appropriating another's labors, can have anything of his own with which to pay damages.—Mr. James N. Bishop, there are many men on Blackwell's Island, sent there for offences which appear respectable by the side of yours.—And yet you style yourself a "Professor of Botany and Horticulture."... The *News* states that this article on "Soil for Potting Plants," is to be followed by one on "Temperature and Moisture."—As that is the title of the very next chapter in "Practical Floriculture," it would look as though the "professor" was going through the book. Of course the *News* will put a stop to these antics, and relegate J. N. B. to the obscurity from which he has temporarily emerged.

Bee Notes.

BY M. QUINBY.

Twenty-five years ago I bought honey in several parts of this county, (Montgomery, N. Y.). Box hives were then used, and the average yield was not over ten pounds per hive. A man in the southern part of Herkimer Co., N. Y., had the past season the care of 175 hives, from which he obtained over 17,000 lbs. surplus. Another man, not far from the Central R. R., in the same county, started with 102 stocks in the spring, and obtained from them over 10,000 lbs. surplus. Other parties, with smaller numbers, have succeeded as well. I mention these circumstances to show that we have gained something in our knowledge of bee-keeping. Here is an average of about 100 lbs. per hive, instead of 10 lbs. Allow me to state what one person obtained the past summer, in extracting from one hive in about two months. Bees worked very slowly early in the season; fruit-tree blossoms and clover yielded but little, and the bees did not gather freely until the last of June.

June 29th he got only 5 lbs.	Aug. 1st the yield was 65 lbs.
July 4th the yield was 11 "	" 5th " " 72 "
" 8th " " 30 "	" 8th " " 46 "
" 16th " " 31 "	" 11th " " 62 "
" 23d " " 58 "	" 17th " " 43 "
" 25th " " 57 "	" 26th " " 37 "
" 29th " " 65 "	
Total.....	582 lbs.

All of this, except 80 lbs., was white honey. This case would indicate that there was a gain in frequent extracting, and furnishing as many empty combs as the bees could occupy. The dry pleasant weather of September, was more favorable for the secretion of honey than usual. Some colonies have obtained almost enough for winter, from the asters and golden rods. I have heard of but one man whose bees have added honey to his unfinished boxes from these flowers, and it seldom occurs in this section. The slovenly farmer, who suffers these weeds to mature, may feel that he has contributed something to the sweets of life.... It is presumed that all bees destined for winter, are in proper order at this time. For all localities above the latitude of New York City, bees winter safest in the house. If there is no warm, dark room, proportioned in size to the number of bees to be wintered, prepare one at once. If a place is arranged in the cellar, let it, if possible, be directly under the living room, where there is a fire, or adjoining a room with a fire. If the cellar contains a furnace, let a close partition separate the bees from it. Let them be disturbed as little as possible. In carrying them in, let it be done so quietly that they will know nothing of it. Provide a thermometer that you may know the temperature of the room. If you can keep it at 45° there will be little risk in ventilating, whether from the bottom or top, very little will do.... A word now in regard to the idea that bees are guilty of depredations on grapes and other fruit. I hope those who have made these accusations, have made further observations this fall. The weather has been so warm and fine, that the bees have been less eager for the juices of fruit than usual. I noticed—particularly on Concord and Delaware grapes—a strip of skin near an eighth of an inch broad, peeled off half around the grape, leaving the pulp exposed, and as far as I could see, unmolested by bees or wasps. No sane man will suppose that bees will leave the hive before sunrise, do this mischief, and return without being seen. Now whoever has noticed these things this fall—and I hope some have been sufficiently interested to do so—will do the public a great favor to report accurately what he has seen. According to observation, after the exposure of the peeled grape a few days, the bees discovered the tempting morsel, and sucked them nearly dry. In the cool spell of weather, which occurred the first of October, when the bees did not fly at all, I noticed grapes damaged

in the same way. The question now arises, what begins the mischief,—it is evidently not the bees. Will some one help find out? Most of the grapes injured, were perhaps 60 rods from the house. Others of the same kind, were in the garden, and near it. Very few were molested near the house, while those further off suffered greatly—another proof that bees are innocent. I once suspected the robin, but I did not see one during the month of September. Mice might do it, as clusters of grapes that hung over the wooden bars of the trellis, were molested the most. Will not some one set a trap and catch something. Let us have facts to depend upon, and not be obliged to guess.

Ogden Farm Papers.—No. 57

"I am a young man, married, and have been for several years out of health, so that I have been unable to pursue my vocation of book-keeping. I have recently settled in a healthy mountain region in the South, and need some means for my support. I am without capital, but I can borrow a few hundred dollars. If I can hire a place that I want, how would it do for me to buy six cows? I can readily sell their milk at 30 cents per gallon. Six cows cost—say \$40 each—\$240; 2 gallons milk each day, for 30 days, at 30 cents per gallon—\$108; 14 lbs. of hay, and 12 lbs. of meal per day, each—2,520 lbs. of hay, and 2,160 lbs. of meal per month. Hay is worth \$15 per ton, and meal is \$20 per ton. This will cost per month—say \$40.60. A man's wages and board—say \$14. This will leave me about \$50 per month, which would make me independent. I would like to have your advice." What is one to do in such a case as this? How can one give any advice that will not seem hardhearted? Probably there would be few shorter roads to the entire loss of whatever might be borrowed for this purpose, than the course laid out by my correspondent. If he were a laboring man, and were able to take care of a cow, and to milk her himself, and to carry the milk to his customers, he might, perhaps, by beginning in a small way, make his subsistence, and become comfortable in time. But here is a man, unable to work, and having no practical knowledge of cattle, setting down and deluding himself with the hope that he would be able to make an independent living on borrowed capital and hired labor, where a laboring man, having much less expense, would find it difficult to get along. These agricultural computations are the most deceptive things in the world. 8 quarts per day as an average, is 2,920 quarts per annum, which is pretty nearly twice the average product of the good dairy regions of New York State. With such cattle as one would find at the South, fed and cared for as they probably would be, the estimate is most extravagant. Then, what sort of care would six cows receive at the hands of a Southern negro, whose wages and subsistence would cost less than 50 cents per diem.

In fact, the whole proposition, were it not seriously made by a suffering and hopeful man, would be ridiculous. As it is, it is only very sad; and it would not merit notice here, were it not for the fact, that there are all over the country—and perhaps largely among the readers of the *Agriculturist*—thousands of men whose hope for success in life is turned away from employments which they understand, and for which they are qualified, and centered upon an intricate and difficult occupation, which requires more skill, patience, endurance, strength, and judgment, than almost any other within the whole range of human industries. It is another instance of farming upon paper,

than which nothing can be more delusive. Agriculture can do much; it has its possibilities, and opens a certain future for those who rightly apply themselves to its prosecution; but it is very far from being what its more enthusiastic and infatuated (and less experienced) admirers think it to be. In this case, as in many others, I am quite incapable of advising my friend what to do; but it is the easiest and safest thing in the world to advise him not to do what he proposes.

It may be remembered by some of my readers, that I last year paid \$200 rent for 2 acres of clover, a part of which we used for soiling, and another part made into hay. This same field was offered to me this year, but I declined it, because I did not believe that it would again produce an abundant crop of clover. The owner said he would convince me, that with liberal top-dressings of seaweed and stable manure, it could be made to do so. It received last winter such a manuring as falls to the lot of few farm fields, and it is now (September 15th) covered with a heavy after-growth, in which the clover is conspicuous and uniform. It has been mown twice for hay, and the whole crop has passed over my hay-scales, and is recorded on my weighing-book. The first cutting was June 20th. The grass was more than half clover, the rest being timothy; it was not so well dried as it should have been, and although safely stored in a barn, it is somewhat injured from heating; at the same time, it was not so wet but that it has kept, and it is now in fair condition for fodder. The amount weighed, was a little over 8 tons—I assume that properly cured, it would have weighed 6 tons. The second cutting was made August 10th, and the crop, thoroughly cured and in the best condition for storing, weighed 336 lbs. more than 4 tons. The whole of both cuttings was at the least calculation, equal to fully 5 tons of well cured hay per acre. Comment upon this statement is unnecessary.

In a recent number I gave an account of a man calling himself an agricultural chemist, who went about our island analyzing soils by tasting, and prescribing different manurial amendments, by which their "latent fertility" might be developed. We number among our farmers many hard-headed, sensible men, of considerable property, who flatter themselves that their eye-teeth were cut long ago, and that they are not to be caught with chaff. Had any one had the temerity to advise them to apply to a thoroughly scientific man, like Prof. Johnson of Yale College, for advice as to the treatment of their particular soils, he would probably have been hooted and sneered out of the community for a "book-farmer." Had Prof. Johnson been applied to to give advice based on soil analyses, he would have replied that it lies entirely beyond the reach of any science, to render valuable aid in this way. Yet, here comes an arrant quack, who captures one substantial farmer after another, and convinces him that he can, for a consideration, show him the short cut to agricultural wealth. So far as I can learn, his willing victims in this county may be numbered by scores, if not by hundreds, and they include men who pass for the most sensible among us, but who, like the rest of the world, evidently like to be humbugged. One, a near neighbor, took this "chemist" to two fields, which have been cultivated for several years as a market garden. He duly tasted and advised, and here is his advice: (Copied literal-

ly from his pencil note, on a dirty half-sheet of note paper.)

" Pond lot.	1 barrel loam.	10 lbs.
" Lawns.		Soda Ash.
		10 lbs.
		Lime.
		5 lbs.
		Copperas.
		5 quarts.
		Salt.
		2 lbs.
		Chloride of Lime.
" Soda ash and Lime slacked together.—Dry Slack.		
" Pound the Copperas.		

" Rest of land,	1 barrel loam.	
6 lbs. Soda Ash.		
6 lbs. Lime.		Slack lime,
4 qts. Salt.		and
3 lbs. Copperas.		Pound Soda Ash.
4 lbs. Caustic Soda."		

His fee for this valuable service, was \$40. Comment is again unnecessary.

I have received a long printed report of an experiment with the Deep Can System, made by the Solebury Farmers' Club, in Bucks Co., Penn. A committee was appointed to examine and experiment in setting milk, both deep and shallow, at the farm of a Mr. Reeder. I do not clearly understand the arrangement of the patent apparatus, by which the water in the pool was kept cool by ice water, but so far as one can judge, the trial seems to have been a fair one, so far as the experimenters could make it so.

"The trial commenced on Monday morning, August 10th, 1874. On account of scarcity of milk in the mornings, but 8 gallons were used at a time during the trial. Four gallons of measured milk were put in one deep can, filling it just 16 inches deep, and weighing 34 pounds. The same quantity of this previously mixed milk, by weight and measure, was put in 4 ordinary tin milk pans, (4 quarts to the pan) and filling them 3 inches deep. This was repeated for 14 milkings, one week—making a total of 476 pounds, or 224 quarts of milk, 16 inches deep in 14 cans; and the same amount in 56 pans, 3 inches deep.

"The water in the pool, as before stated, was at a temperature of 58°; when a can of warm milk was immersed in it, it raised the temperature to 60°, but at the expiration of 10 or 12 hours, it would be lowered to 58° again, by the inflow of fresh ice water. A piece of ice was put in the pool after the first day, so as not to let the temperature be varied any more than could be helped. The pans of milk were set on a stone floor, where the temperature was 60°. During the whole trial the temperature ranged as follows: In the pool, from 58 to 60°; in the milk room, from 60 to 62°. Great care was taken to preserve this uniform temperature during the whole trial, by admitting cool air at night, and excluding the warm air during the day, which necessary feature is under complete control. The milk in both cans and pans stood 48 hours, when it was skimmed. The cream raised one inch in depth in the deep cans. The amount of cream obtained from the deep cans was 46 pounds, from the shallow pans 57 pounds. The last skimming was done on Tuesday evening, August 18th, when the cream was placed in a cooling cupboard, and the temperature lowered to 54°. The churning was done Wednesday, August 19th. The 46 pounds of cream obtained from the deep cans, was churned first—butter came in 30 minutes, and yielded 15 pounds 10 ounces. The cream from the shallow pans (57 pounds) was churned immediately afterwards—butter came in 50 minutes, and yielded 21 pounds 6 ounces. The result of this experiment, which was conducted as fairly as possible, indicates a gain of 5 ²/₁₆ pounds in favor of the shallow pans, or over 25 per cent."

I am entirely at a loss to account for this result, nor have I any equally careful experiment to set against it. At the same time, I am quite satisfied that were the facts known, there would be found some good reason for questioning its value. Before we settled upon the Deep Can System ourselves, we made alternate trials, week and week about, with the deep and shallow setting. We invariably got a trifle more butter from the deep than from the shallow, the herd being the same, and getting the same treatment, slightly more, but not enough more to be of consequence. The improvement that we found was in quality; in a great saving of labor, and especially in a greater uniformity, without regard to the temperature of the air. Since that time, some three years ago, we have entirely abandoned shallow setting, and remained more than satisfied with our deep cans. Surely if there had been anything like the difference in quantity, which the Solebury experiment developed, we could not have failed to detect it, and should certainly have abandoned the system. Had the quantity of cream obtained at Solebury been larger in case of the deep can setting, I confess I should have been somewhat staggered by the difference in the amount of butter, but if anything is determined beyond question, not only by my own experience, but by that of others pursuing the same course, it is that, whatever may be the amount of butter produced, the amount of cream is universally much larger, a fact which is undoubtedly due to the less exposure of the cream to the drying effect of the air. Cream taken from a shallow pan, set for even 36 hours, is almost universally somewhat clotted and leathery from its drying, while that taken from deep cans, is always thin and fluid, showing greater content of water, and being therefore much more in quantity.

So long as milk remains fluid, (free from coagulation), and so long as the particles of cream are lighter than the particles of milk, as they always are, these must inevitably rise, even if set eighteen feet deep instead of eighteen inches, and we find not only a very large amount of cream separated, even in 24 hours standing, but also the peculiar blue look, which only thoroughly de creamed milk can have; and, after skimming, the milk returned to the pool, in order to avoid curdling, never raises any sensible amount of cream; it is in fact thorough skimmed milk.

I have no intention of entering into a discussion on this subject, for the reason that not living at the farm, and not being able to give constant personal attention to the details, I could not make an experiment for which I would be willing to vouch. I have stated Mr. Reeder's case in his own words, and must leave my readers to draw their own conclusions, and make their own investigations, but I shall not, myself, be led by the disastrous results he sets forth, to change my present system; feeling confident, that were his water pool like mine, and his milk and his processes like mine, he would find the result entirely different from that which his own experiment has developed. Since our dairy was established on its present basis, we have never, in the coldest or in the hottest weather, had the least difficulty in making butter of uniformly good quality, and entirely acceptable to our over-particular customers.

We are all of us the better now and then for intelligent criticism, and, although I have had differences with Mr. William Crozier, of the Beacon Stock-Farm, on the subject of the

amount of butter which a large herd of cows may be made to yield; I have always been ready to concede to him the merit of being a thoroughly good, practical farmer, and have regretted, more than once, my inability to study his practical operations. He has recently visited Ogden Farm, during my absence, and writes me the following:

"I was well satisfied with my visit. We ate of your butter, which is delicious, but I do not like your way of making it as I do my own. I always think more of our little dairy, than any I have seen, although your method of heating is superior to mine, and I will adopt your plan. Your barn is a good one—the best I have seen—although the open spaces behind the cows must be very bad. In winter there must be a furious draught in it. Your crops of potatoes and turnips are not up to mine. Nor is your plowing. Please adopt better cultivation throughout, as there are many looking toward you for their education. Your stock bull I think is splendid in every respect, although I would like a lighter color. Your calves tempt me to offer for 3 of them \$100, each, [he picked out my best three, for which I ask \$175, each.] Your cows I must congratulate you on; they are the best throughout that I have seen, that is, for so many, far better than I expected from hearing from your visitors—which makes me think visitors often do not know what they are talking about. I was much pleased with my visit, and trust you will excuse me for writing you the impressions your farm made on me throughout. I hope you will put on your farm better plows, and bigger horses, and employ better plowmen, and not let the face of a weed be seen on the O. F."

To be entirely frank, I fear we are more open to Mr. Crozier's rebuke, than entitled to his compliments. However, as we only plow about 8 acres a year, and as deep plowing is not suited to our soil. I fear it would hardly pay us to make the radical change he suggests; we must also plead guilty to the weeds he hints at—the more shame to us—the land is rich, and while its natural tendency to grass keeps our meadows clean, we do have more rag-weed in our fodder corn than is respectable, and I have as yet been able to devise no way to get rid of it profitably. I do not like our open barn-floor, and should not repeat it if we were to build anew, but as the cellar is closed bottle-tight in winter, we have no perceptible draught.

On the whole, perhaps because I realize more thoroughly than a casual visitor does, what our drawbacks are, I am glad to have been let off with so mild a criticism.

An enthusiastic farmer in Mass., says: "There ought to be millions more sheep in New England than there are to-day. I believe it is the most economical, and only practicable means of restoring the fertility of the soil. Why does every English farmer think sheep husbandry a necessary part of his plans? and wherein are we in New England differently situated? I would like to see that inquiry answered by you in print. The objections are dogs and fences."

Probably the true reason for the neglect of sheep complained of, and one that is much more effective than dogs and fences, is the very important one of Custom. English farmers keep sheep very largely because they have the habit of keeping them; our farmers in New England have never been in the practice of keeping them to any very great extent. The dog and fence difficulty is quite as prominent

in England as here, perhaps the fences are on the whole better, but the dogs are, if anything, worse, and a large proportion of the flocks are kept on outlying land, where fences and dog laws are almost unknown.

Probably the reason why we do not keep sheep more extensively than we do, is because we have not learned how important they are, and how easily they may be kept in a systematic way and under proper care. In the more highly farmed parts of England, where, as everywhere else, sheep are considered indispensable, hurdles are largely used, and the flocks are sufficiently large for the services of a shepherd to be profitably employed. The best services that could be rendered toward the encouragement of keeping sheep here, would be by beginning with the recommendation of hurdles. The hurdle is the true missionary for the dissemination of the sheep keeping doctrine; with its aid sheep are easily confined to small areas, which they thoroughly depasture, and are with little labor moved to fresh ground. In this way do we not only insure the uniform feeding of the land, but we have placed within our reach the very best means for the equal distribution of manure, the sheep being fed with grain or other food not grown upon the land to which they are confined.

Hurdles in England are usually made of rough poles, scarcely larger than stout bean-poles, often tied together with willow withes, and so light that they are easily handled. Their cost is slight, and the labor of removing them is but trifling.

How to Build a Snow-Plow.

The snow-plow here illustrated is built so as to be fixed upon the forward part of a double sled. The frame is made of 4x4 oak scantling, and is similar in form to a double mold-board plow. One runner is fixed to the forward part, at such a distance below the edge of the plow as to raise it to clear obstacles such as stones or frozen mud which may be in its way. Four inches would probably in general be a safe distance. The hinder part of the plow rests upon the sled as shown in the engraving,

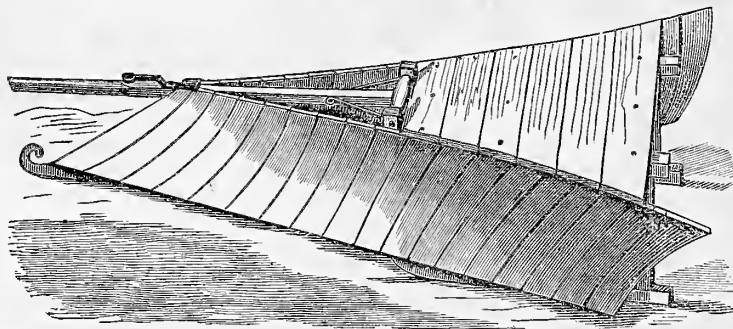

MANNER OF MAKING A SNOW-PLOW.

and is bolted to it. A long tongue is fixed into the place of the ordinary one, and is fastened to the front of the plow by an iron strap, which is bolted to the frame. The hinder portion of the plow may be covered over with boards, and a seat fixed firmly upon it. When it is used, it is best to load it as much as possible. The sides of the plow are made of half-inch oak or basswood strips, steamed and bent into shape. The outer surface of these strips

should be dressed smoothly, which will make the draft easier.

The Emptying of Water Stored for Irrigation.

There are many small streams which might be used for irrigation, were it not that their volume is so slight that their water would have too little force and volume to cover any considerable extent of land. In countries where

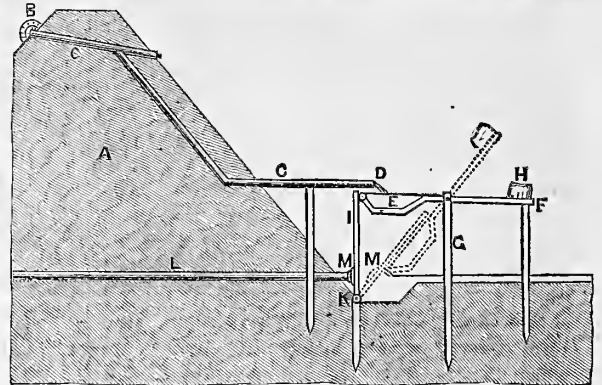

OUTLET TO A DAM.

irrigation is largely practiced, such streams are not allowed to lie idle, but their water is stored up until enough has accumulated to overflow the land with good effect. The contrivance adopted for this is very simple and inexpensive, and might easily be applied to many circumstances existing in America. The accompanying illustration will show the arrangement. A portion of the bank or dam, by which the water is held back is shown. Leading through the bottom of it is a pipe L, properly protected by a grating at its upper end, which serves to empty it from time to time. The mouth of this pipe at M, is closed with an india rubber ball, or some similar device, fitting its orifice, and fastened to a board I, which stands vertically in front of it, being hinged at K. This board is held in its vertical position by EF, the end E, being formed in the shape of a basin, capable of holding a considerable quantity of water, and the end F, having a counterpoise of stone or wood sufficient to return it to its horizontal position when it has been tilted.

Through the upper part of the dam is placed the pipe C, also protected with a grating at B. The end of the pipe D discharges into E. When this is filled, it becomes heavier than the counterpoise H, and is tilted, withdrawing its support from the board I, which is forced back by the pressure of the water in the pipe L, and is held out of the way so long as the stream through L has sufficient velocity to counteract the force of the counterpoise. When the pond or reservoir is emptied—that is,

when the stream through L has stopped flowing,—the counterpoise raises E, and forces the board I back to its place, and stops the mouth of the pipe. To prevent water flowing over the dam, in case of any disarrangement of the apparatus, the pipe leading from B has a second opening on the face of the dam.

By this arrangement the small amount of water at command is collected until its quantity is sufficient to irrigate the whole field.

Ayrshire and Native Cows Compared.

Dr. E. Lewis Sturtevant, of Waushakum, Ct., favors us with the following statement of the comparative yields of pure-bred Ayrshires and a picked herd of native cows, which shows a great difference in favor of the Ayrshire cows, bred especially with reference to a large yield of milk for many years:

The proprietors of Waushakum Farm entered into the raising of milk in the summer and fall of 1866, with the idea that the most profitable stock to keep would be the highest class of grade, or so-called native cows. The best were accordingly purchased, without regard to price, and fed high, in order to develop the best results in milk, and also that the animals, when dry,

or in case of accident, could be quickly prepared for the shambles. In 1868, hearing so much said in favor of thoroughbreds, we concluded to experiment on a small scale; so during this year we had two Jersey and four Ayrshire cows on our premises. In 1869 we had become so well convinced that the Ayrshire breed would be the most profitable for our uses, that in December, 1869, eight cows in calf were procured from Scotland. A few other imported cows purchased at low prices on this side, and the progeny of imported cows, constitute our present herd. As a careful system of accounts has now been kept with each cow in our possession, giving the daily yield of milk in pounds since 1866, we are enabled to present a few facts relating to a herd kept during seven years; and these facts show the effect of a change in breed; not clearly, however, for the natives were old cows in their prime and fed especially for milk: the Ayrshires, a breeding stock, including heifers in milk, and fed with reference to their healthfulness and durability as a breed. During these seven years we have a record of 68 annual yields from 34 different native cows, and 63 annual yields from 18 different Ayrshire cows. Total of the 68 native yields, 324,723 lbs., or per cow, 4,775 lbs.;

total of the 62 Ayrshire yields, 329,160 lbs., or per cow, 5,309 lbs.; difference in favor of Ayrshires, 534 lbs. for each cow. The 34 native cows were the best of 50 owned during this time; the 18 Ayrshire cows include every one that was owned during these years. Separating the

ten best Ayrshires, selected from 18 cows, gave an annual average of 7,317 lbs. Of 62 Ayrshire yields, 19.3 per cent were over 6,500 lbs.; 40.3 per cent over 6,000 lbs. Of 68 native yields, 11.8 per cent were over 6,500 lbs.; 16.3 per cent over 6,000 lbs. If the Ayrshire heifers are left

out of the consideration, we have the comparison between native cows in each case, and a new summary. Native yield, 4,775 lbs. per cow; Ayrshire, 5,571 lbs. per cow. A difference in favor of the thoroughbred of 796 lbs., instead of 534. The percentages will also be changed as follows: Yields over 6,000 lbs.: Ayrshires, 42.8 per cent; natives, 16.3 per cent. Yield over 6,500 lbs.: Ayrshires, 21.4 per cent; natives, 11.8 per cent. I trust these figures are sufficiently in detail for the purpose of comparison, and may be of interest.

The two cows whose portraits are given herewith, are members of this herd. Lady Kilbournie was purchased in December 1871, and her yield of milk up to August, 1874, was as follows: in 1872, 7,429 lbs.; in 1873, 7,124 lbs.; in April, 1874, she calved, and in August of this year she gave 1,097½ lbs. Her highest yield was in June, 1873, when newly calved, giving 1,338 lbs. in that month. This cow weighs about 850 lbs.—Georgia has been in the herd since June, 1871. Her yield in 1872 was 7,127 lbs.; in 1873, 6,094 lbs.; and when fresh in August last, gave 1,417 lbs. in that month. Since June, 1871, up to the present time, she has given milk continually, excepting in July, 1873. In June, 1873, she gave 110 lbs. of milk, calved, and in July gave 955 lbs. Her weight is about 890 lbs. These yields are not given as being anything wonderful, but as those of a working herd in ordinary condition, and yielding milk for profit. They show sufficiently that the extra cost of a pure bred animal is well repaid in her more valuable produce not only of milk, but in her progeny, as each of her calves at maturity should be worth much more than the best native cow. This extra value is easily calculated.

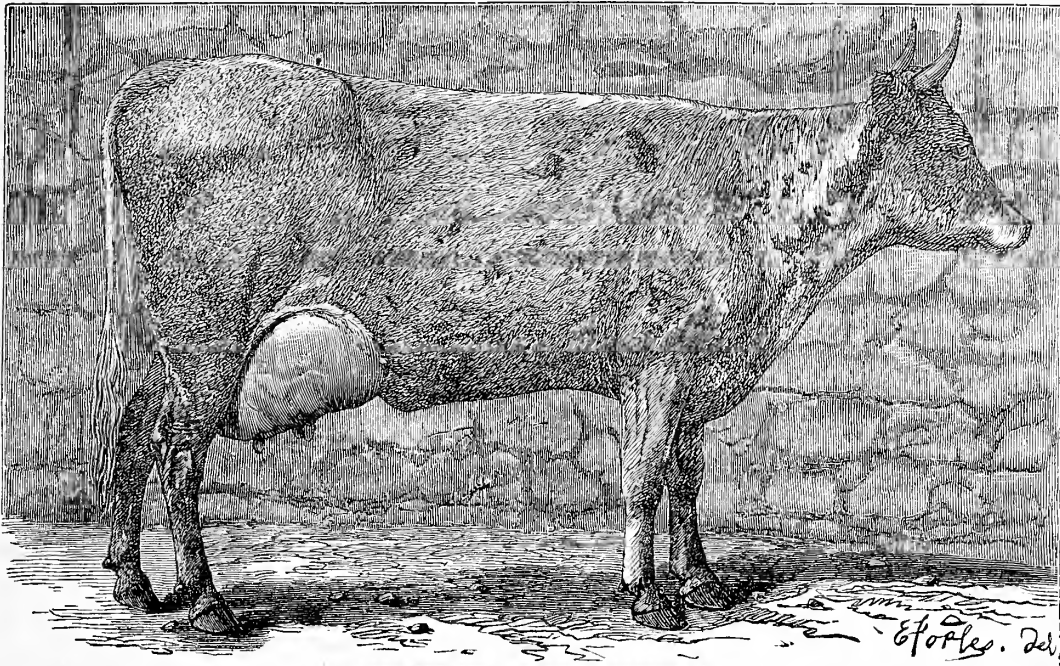

AYRSHIRE COW "LADY KILBOURNIE."

period of seven years into two portions, we have for the "native years" 1867-8-9, an average yield of 4,603 lbs. for each cow; for the Ayrshires, 1870-1-2-3, an average of 5,623 lbs. per cow. A difference in favor of the Ayrshires of 1,020 lbs. Taking the best average year for each class, we had best average for any one year, for natives, 4,834 lbs.; for Ayrshires, 6,047 lbs., or 1,213 lbs. in favor of the Ayrshires. Average daily yield, per year, while in milk: natives, 15.7 lbs.; Ayrshires, 19.0 lbs.; a difference of 3.3 lbs. a day. Aver-

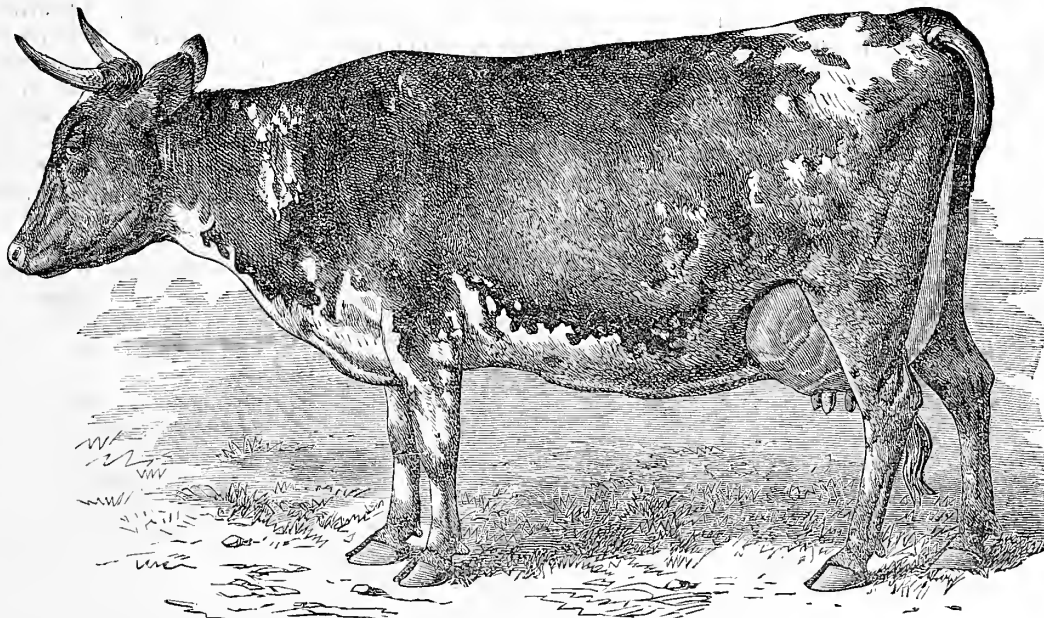

AYRSHIRE COW "GEORGIA."

age daily yield of each cow, each year, for the whole year: natives, 12.5 lbs.; Ayrshires, 15.5 lbs.; difference in favor of Ayrshires, 1,095 lbs. yearly. The ten best natives, selected from 50 cows, gave an annual average of 6,943 lbs.; the

Walks and Talks on the Farm.—No. 131.

Yesterday I got a letter from a gentleman in New South Wales. He said he was a reader of the *American Agriculturist* and wanted to know if I could send him some pigs. "I imagine," he said, "that I could get some pigs by mail!"—I noticed sometime ago that a scientific gentleman proposed to put pigs to sleep in the fall and let them lie dormant during the winter, waking up in the spring in time to go out to fresh grass in the pastures. Perhaps this Australian gentleman has a similar idea. We could take a young pig, weighing say 30 lbs., put him to sleep, pack him carefully in a neat box, put the necessary postage stamps on it, and in a few minutes he would be on his way to San Francisco. The Post Office Department carry live bulbs to any part of the United States for 8 cents per lb.—Why not live pigs? ["Why not," to be sure—not the least objection in the world, only it is just possible that your Australian friend might object to having even an Essex in 4-lb. junks, as that is the greatest amount the law allows to go in one parcel.—Ed.]

It is hard for a plain, slow-going farmer like me to realize what an age we live in, I can recollect taking my first journey on a stage coach thirty miles from home. I thought I was a great traveler. Some time ago I was going from Rochester to Utica. There was a little girl going about the car and evidently well acquainted with several of the passengers. I spoke to her as she passed. "Have you come far on the cars?" I asked. "Oh, no, sir," she replied. "I have not come far on the cars. I only came from San Francisco on the cars. I came from Yokohama on the steamer."

When Charles Collings wished to show what improvements he had made in Durham cattle, he fattened an ox which was then put on a carriage and drawn from town to town for exhibition. He is spoken of in Short-horn annuals as the "Durham ox that traveled." What would a Texan steer say to his pretensions as a traveler?

If in these days a farmer makes any real improvement in seeds, vegetables, or animals, the fact is mentioned in the agricultural papers, and it is soon known throughout the world. Young men are apt to think that all the great discoveries have been made, that there is now no chance for further invention or improvement. It is a great mistake. There never was, at any rate in agriculture, so many opportunities for acquiring reputation, honor, and remuneration, as at the present time. Let young men bestir themselves.

The severe drouth has seriously checked the growth of the mangels—and I am trying to console myself with the reflection that small, well-matured roots, are more nutritious than large, over-grown immature ones. I sowed the field at different times, for two reasons. First, because it was a good deal of work to get the land in proper condition, and I thought that the earlier I could sow the better, and that if I waited till the whole field was well prepared, it would be getting late; and, second, I thought it would be better not to sow all at one time, and thus give me a dozen or more acres that would all want hoeing at once. I drilled in my oats and peas, April 22; barley, April 30, and the first mangels May 2. The last sowing was two weeks later. The earlier sowings came up far thicker and the plants

were stronger and grew better. And, furthermore, the weeds were not so numerous, and it was far less work hoeing. Everything seemed strongly favorable to early sowing. But during the severe drouth in August, the late sown began to catch up, and by the middle of September, the drouth still continuing, the roots were decidedly larger and the leaves more luxuriant. I know of no reason for this except that the land that was sown late got an extra plowing. At first the late crop was so full of weeds that I thought that it would cost more to clean it than it was worth.

During the drouth, those farmers who had a good patch of corn fodder got full pay for their labor. In five cases out of six, however, farmers in this neighborhood sow their fodder corn broadcast, and in a dry season, when the green fodder would be of most value, the crop is burnt up. There is no fact more clearly proved, I think, than that corn for fodder should be drilled in rows, and the land kept clean and mellow by the frequent use of the cultivator.

I wish the butchers and drovers in New York or Chicago would get up a Fat Cattle Show to be held every year in December. I do not see why it could not be made as interesting and useful as the great Smithfield Club Cattle Show in London. The meat supply of New York and New England comes largely from Illinois and States west of the Mississippi. Between New York and Chicago there are millions of acres of land under cultivation that are not producing more than half a crop. Depend upon it, this land is not going to be abandoned. I think the agriculture of this section is steadily improving. We are cultivating our land more thoroughly. Many of our farmers are using artificial manures, and not a few are endeavoring to enrich their land by keeping more stock and buying more or less food, and thus making more manure. To keep more stock for beef, mutton, and pork, is at present a cheaper method of enriching our land than to buy artificial manures. We must, however, raise better stock and furnish meat of extra quality, or we cannot compete with the cheap corn-growing sections of the West. Our markets are flooded with cheap beef and mutton. It is wretched stuff—unprofitable to the producers, and still more unprofitable to consumers. Let the butchers of New York tell us what they want. Let us have a good show of animals ready for the shambles, and let the judges decide what breeds or grades are best, and we shall know where we stand. If New York is willing to pay for good meat—and it is—we should soon learn how to produce precisely what is wanted. Let us have a good show. Let the prizes be awarded and the animals be sold to the butchers, and let consumers and producers meet together and study the facts which will in this way be brought to light.

"What did you see at the State Fair?" asks the Deacon. "I saw a good many old friends, and this to me is one of the pleasantest and most profitable feature of these annual gatherings."—More than a dozen people asked me "How's the Deacon?"—And one day I went into the General Superintendent's office. I saw no one there who knew me, as I supposed, and I told the young man in charge that I was an exhibitor and wanted a couple of tickets for my men. "Here they are," he replied promptly and politely, "and if you will bring the

Deacon along I will give you one for him." I could not persuade the old gentleman to come. But he was none the less interested in talking over all that occurred. "I see you got some prizes for your sheep and pigs," he remarked, "but I hear there was not much competition."—"I got the first prize for white winter wheat," I replied, "with the Diehl in competition with the Clawson—and this pleased me. I also got the first prize for six-rowed barley and the first for mangel-wurzel."—I had twenty-four entries and took twenty-three prizes. I got \$208 in prizes at the State Fair, and \$64 at the Western New York, which was held at the same time. I got the first prize for everything I showed at the Western New York Fair. I mention this in no boastful feeling. I am simply tired of hearing farmers (who don't take an agricultural paper) sneer at editors and writers. We are not the humbugs and ignoramuses these men imagine us to be. I can always tell in talking to a farmer whether he takes the *Agriculturist* or not. If he does he has some suggestion to make that is often of use to me, or he asks an intelligent question. The other man seems to think I "farm on paper," that I was born with a silver spoon in my mouth and no brains in my head; that I discard barn-yard manure and depend on guano; that I feed my pigs on plum cake and wash them with rose water. And when he finds that I plow, and sow, and harrow, and cultivate as other farmers do, he thinks I am certainly a humbug—because I am not what he expected me to be.

I got one new idea at the Fair from Carl Heyne. He asked me to come and see his Silesian Merino lambs. They were splendid—large, well-formed, and completely covered with long, thick, fine wool. "But, Carl," I said, "these can't be lambs. They are almost as heavy as my Cotswold lambs. They must be yearlings."—"No," he said, shaking his head and smiling. "Lambs."—"They must have come very early," I replied. He smiled and nodded his head. "February?" I queried. Another smile. "January?" Another smile. "December?" Another smile. I have smiled to myself several times since as I thought over the matter. If I had said "November," I presume he would have smiled assent, and I am not sure if I should not have got the same response if I had said "October" or "September." I suppose a lamb is a "lamb" till it is sheared, then it becomes a "shearling." "Is it well," I asked, "to have lambs come so early?"—"Better," he replied. "We have plenty of hay and roots and can feed the ewes well in winter. In the spring the weather is wet and the grass watery and poor, and young lambs do not thrive on it. If the lambs come early they can be well fed and cared for all winter and spring, and by the time the grass is rich and abundant they are ready for it."

All this, at first sight, seems quite unnatural. But few of the processes of agriculture are natural. It is not natural to milk a cow or shear a sheep, or make hay, or provide shelter and supply the wants and look to the comforts of our stock. We find no objection to have cows calve in September. Why may it not be quite as well to have our lambs come in the fall? "I have always found lambs that come accidentally in the winter," said the Deacon, "a nuisance."—"Yes," said the Squire, "it is best to knock them on the head at once and have done with it. It is all well enough for you amateurs who keep a few pet sheep and like to

fuss over them, but it won't do for a farmer who keeps a large flock."—"But," I replied, "Carl Heyne is one of the most experienced shepherds in the United States. He has charge of a flock of over 800 sheep, and is celebrated for his successful management. When such a man says it is better to have lambs come in the fall or early winter—and practices what he preaches—the matter is worthy of consideration and discussion."—"For my part I am half converted already, provided the ewes can be induced to fall in with the idea. I suppose this matter can be brought about by feeding, weaning, etc.

The Holstein cattle this year, as last, attracted much attention. We cannot have too many good breeds in this country. There is room and place for all of them—from the diminutive Kerry and deer-like Jersey to the noble Shorthorn and Holstein. There was a better show of Herefords than we have had for some years. There was rather a small show of Jerseys and Devons, but some capital animals amongst them. Charles and James N. Wadsworth, of Geneseo, and George Butts, of Manlius, made a grand show of Shorthorns. The Ayrshires are steadily gaining favor in the dairy districts, and there was a large display. "I suppose," said the Deacon, "the Ayrshires give a great mess of milk, but it is not as good for butter as that from one of our common cows."—"Perhaps not," I replied, "but farmers who take their milk to a churn or butter factory want quantity, and so do milkmen, and even you and I, who keep our milk at home, like to see our cows fill the pail. But after all, the question is not which is the best breed in itself considered, but which gives us the best animals for our purpose, when crossed with such stock as we now have on our farms. The cow "Old Creamer," which attracted so much notice at the New York State Fair, at Albany, last year, was a grade Ayrshire—not a thoroughbred. During the month of June she averaged over 40 quarts of milk per day."—"I once heard of an Ayrshire cow," said the Deacon, "that took the prize at the State Fair. The owner gave the necessary affidavits as to the amount of milk produced (which was quite extraordinary), and also that she had received no grain, bran, oilcake, etc., but had run in a pasture, which, I presume he said was a poor one! After the prize was awarded, the fact was proved that during the trial month she had drank the new milk from two other cows!"

In sheep there was nothing new or remarkable. The Shropshire Downs are holding their own remarkably well. The South Downs are receiving less care in breeding than formerly. The best stock of England was brought here, but our flocks seem to have degenerated. It is not an easy matter to keep our sheep up to the English standard. The English breeders feed more roots in winter, and their summers are not so hot, and besides this, we keep our breeds pure, while I doubt if this can be said of many of the English breeders of sheep and swine. We often hear of "improved" Cotswolds, or "improved" Leicesters, or "improved" Berkshires—which I suppose simply means that they have been crossed with some other breed. Bring this "improved" stock here and keep it pure, and it will inevitably degenerate. It is easier to *make* an improvement than to keep it."

The man who gets a good deal of the garb-

age from the city of Rochester to feed pigs, was here the other day. He keeps 200 pigs, breeding some and buying others. He is getting 10 cents per lb. for dressed pigs, and is making money. "My wife," he said, "wants me to buy some of your pigs."—"She is a sensible woman," I remarked. I knew very well that he would not buy any, but I thought I would see what he would say. He selected one, a four-months-old pig. "What will you take for this little pig?" he asked. "Thirty dollars."—"Thirty dollars?" he exclaimed, "my wife would pull my hair."—"You can have him, then, for \$25."—"It is 50 cents a lb.," he said. "I'll take 40 cents."—"Will you take 30 cents," he asked. "Yes."—"I will give you 25 cents per lb.," he said. "Put him on the scales, boys," I replied, "you can have him." The scales were carefully adjusted and the man weighed the pig himself. "Ninety-two and a half lbs.," he said. "You feed them so high, they weigh like lead." I thought, for once, I had sold him a pig, but I was mistaken. "I'll give you \$30 for a pair," he said, "and that's a big price for four-months'-old pigs." He goes to Buffalo and buys Western pigs, a year old and over, for \$5 or \$6 each. They are large-framed hogs, weighing about 100 lbs. each. I presume this pays *him* better than buying a four or five months' pig of the same weight at the same price per pound, but I do not see how those who raise and feed such pigs until a year old, can make anything. The pen of five pigs, four months old, that I showed at the State Fair, weighed 493 lbs. The pen of five, a week or so less than six months old, averaged about 200 lbs. each. These are the "small breed." These six months pigs will not shrink in dressing over 12 per cent. In other words they would dress 175 lbs. These year-old pigs that weigh above 100 lbs. would shrink 40 per cent. They would give 60 lbs. of carcass—and such a carcass! After the bones, skin, ears, nose, and feet were taken out, how much pork would there be left, as the result of a year's feeding? I presume these pigs got their living from the mother until two months old. If killed then, there would probably have been as much available food in them as there is now, and of far better quality. All we have got for ten months' feeding is a certain quantity of bone and digestive apparatus. There are some thirty millions of pigs in the United States. A little more care in breeding and feeding would easily add five dollars to the value of each pig. This would give us more money than we receive for all the wheat, corn, and other grain that we export to foreign countries. I hope and believe the time is not far distant when not a bushel of wheat or corn will leave our shores. We ought to raise all our own wool, and supply the world with pork, bacon, hams, and lard. To ship a car-load of thin hogs from Iowa to Buffalo, and send four car-loads of corn along with them to fatten them here, paying freight and commission on both, is poor policy. To ship corn to Ireland to make pork and bacon for the English market, is equally unwise. Better feed out our corn at home, and learn to furnish the bacon, hams, and lard, which the foreign market demands.

There will be thousands of bushels of American wheat fed out to English pigs and cattle the coming winter. Our millers and grain speculators think we have got such a large surplus of wheat, that they can get it at their own price. I tell them that the corn and oat crops are a failure, and that at the present and pros-

pective price of pork, the Western farmers can well afford to feed their wheat at home to the hogs, and I hope they will do it, rather than let all the profits go to the railroads.

How To Make a Stack Bottom.

The stability of a stack depends greatly upon how the foundation is made. If badly built, the stack will settle irregularly, lean over to one side or other, and when once out of shape it is no longer weather proof. Instead of the water being shed by the covering which has an equal slope in all parts, it is retained in hollows, or obstructed by ridges, and penetrates the interior, and damage results. Although these remarks are too late to apply to the stacking of hay or corn stalks, they are timely as regards straw, and will be worth remembering next season, when hay, grain, or fodder is to be stacked. When making a stack the ground selected should be high and dry, and if it is necessary to make the stack in a low

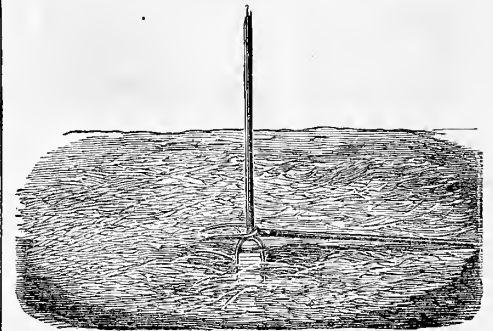

FORMING THE BOTTOM OF A STACK.

place, a frame of posts and poles should be made high enough to raise the bottom of the stack out of danger from water or dampness. In either case the foundation of the stack should be made of coarse waste material, and of a perfectly regular shape. If the stack is to be a square one, the bottom should be accurately laid out by measure. If it is to be a round one this is not so readily done. A round stack is not so easily built up as a square one, nor so readily made to retain its shape. The simple contrivance shown in the illustration will enable any person to lay out the bottom in a circular shape upon which the stack may be built up regularly. After a foot of straw is laid upon the ground or upon the frame, a fork is stuck up in the center. Another fork is placed with the prongs close up against the handle of the first fork, and is moved around it so that the end of the handle marks a circle. The straw is packed closely at the edge, so as to conform to this circle, and a perfectly round foundation is thus made. As the stack is built, the builder should stand in the center which will then be packed down more firmly than the sides. The sides should be carried up straight, or with a very little spread, and should be raked down evenly to keep the round shape. As the stack settles the sides will fall down more than the center, and the stack will spread in consequence sufficiently to throw the rain drip off from the sides; and if any water should penetrate at the top, it will not remain in the center, but will work off towards the caves. On the contrary, if the stack is made so that the center settles more than the sides, the water will gather to the center and go through the stack from the top to the bottom. It will not pay now to waste anything that may be turned to use in feeding stock, and straw that

is well harvested and well stacked after thrashing, is at least as good if not better feed than late-cut hay that is badly stacked afterwards.

A Portable Food Steamer.

It is needless to say anything in favor of feeding cooked food to pigs. The economy and advantage of the practice are undisputed.

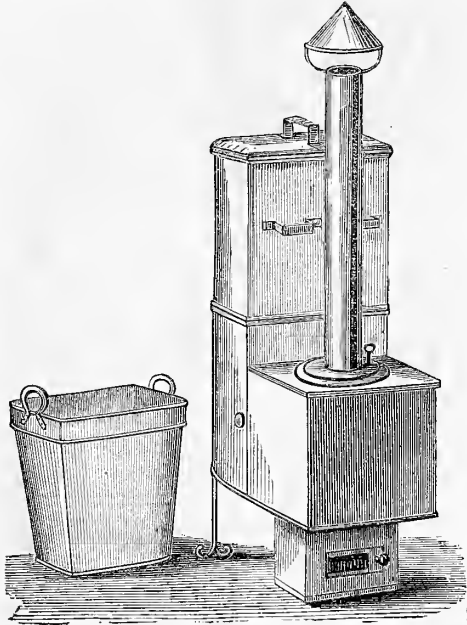

A PORTABLE STEAMER.

The only consideration is as to its convenience or practicability. Where a large number of hogs are kept, every facility will be provided for cooking as a necessity that cannot be avoided. Where a few only are kept, the outlay for an apparatus is usually too great for profit. In these cases the cheap method here illustrated may be adopted. A sheet-iron boiler is made as here shown, with a small fire-box beneath it; the smoke pipe passes through the boiler and through the water contained in it. This economizes all the heating power and requires but a very little fuel to heat the water and make steam. At the rear of the boiler is placed the

set aside to cool, and each steamer should be large enough to cook food for one day. Roots, corn, oats, or coarse meal, may be cooked in this steamer; but fine feed may be cooked in the boiler shown separately. The feed mixed with hot water is placed in the boiler. This being conical, is partly immersed in the boiling water, and the heat of the feed is thus maintained until it is thoroughly cooked. A few small fragments of coal, charcoal, rough wood or corn cobs may be used for fuel. Any tin-worker can make a steamer of this kind from the description and engraving here given. We don't know of any person who makes them, but if some enterprising mechanic would undertake it, and let people know the fact, they would doubtless be largely used.

Temporary Dam for Ice Ponds.

A correspondent wishes to make a temporary pond from which he may cut ice in the winter, and afterwards draw off the water, leaving the stream and its banks in their usual condition. This may be done by erecting a temporary dam in the following manner. Select a part of the stream where the largest space may be flooded with the shortest dam. A place where the banks slope rapidly and above which they recede from the stream should be chosen. In a direct line across this place set some strong fence posts not more than 8 feet apart. They should be set at least 4 feet deep, and bedded with lime mortar and stone or cement concrete to make them perfectly solid. If the dam is not more than 4 feet high these precautions are not necessary, but if of a greater height they will be needed to resist the pressure of the water and that of the ice when its surface is acted upon by the wind. The posts should be strongly braced—the braces being set in the same manner as the posts. These posts may remain always in their position ready for use, and will occupy very little room or occasion very little inconvenience at any time. If they can be set up in a fence row so much the better. All that is needed then is to provide some

carriage bolts, the nuts of which are exposed on the outer side of the dam. The middle panel of the dam is made of planks 8 feet long, so that when it is desired the bolts may be taken out and the planks removed one by one, and the pond drained off gradually. The other planks are made to break joints, the ends being bolted to alternate posts, which will help to strengthen the dam. The lower planks must be made to fit the surface of the ground, and should be sunk three or four inches in it, and the ground well rammed around them. If any leaks occur as the water is raised, which should be done gradually by putting in one plank of the center panel at a time, they should be stopped by throwing in sawdust, tan bark, or leaves, or swamp muck. When the whole is up, the upper plank of the middle panel should be hollowed out sufficiently to allow the waste water to escape, as is shown in the illustration. If there is any danger of the falling water washing the soil away, a sloping apron of boards should be made to receive it. A pond with a surface of half an acre frozen 6 inches thick will furnish 300 tons of ice. Where the ground is favorable, a pond of this size may easily be made at an expense of \$25, and the fixtures will not need renewing for 20 years. The main point is to be sure that the posts and braces are properly set, and that the planks fit tightly; then there will be no danger of the dam breaking or the water leaking away. If the water flows back into other fields, there is no need to remove the fences, even if they are of rails, if they are well staked and such riders as are likely to be covered with water are wired down to the top rails.

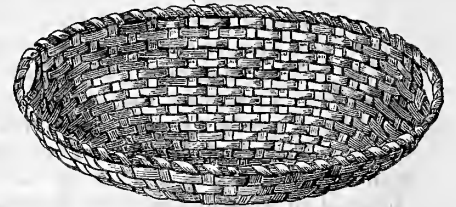

BASKET FOR GATHERING LEAVES.

Gathering Leaves.

Before the ground is covered with snow as many leaves as possible should be gathered from wood-lots and woods. Leaves are soft, warm, clean bedding, and absorb a large quantity of liquid manure. They are excellent in the cow stable, in the pens where the ewes are turned to yean, and for bedding brood sows with young pigs they are better in every way than straw. No young pigs are strangled in leaves as they often are in straw, and leaves harbor no vermin. Besides, they contain much more fertilizing matter than straw, being rich in potash and phosphoric acid. For these reasons the work of gathering leaves should be made one of the indispensable duties of the present season. Woodlands that are used for pasture should by all means be cleared, lest the heavy covering of leaves should smother the grass. Neither these nor other woodlands lose anything by this annual clearing off of leaves. The surface of woodlands is not exhausted by a growth of trees. The roots penetrate deeply and bring food from far below the surface soil. There need be no fear of injuring such lands by removing the leaves every year. Besides, in most cases the leaves do not stay beneath the trees, but are blown hither and thither, and finally rest in fence corners and lanes where they do no good. The small

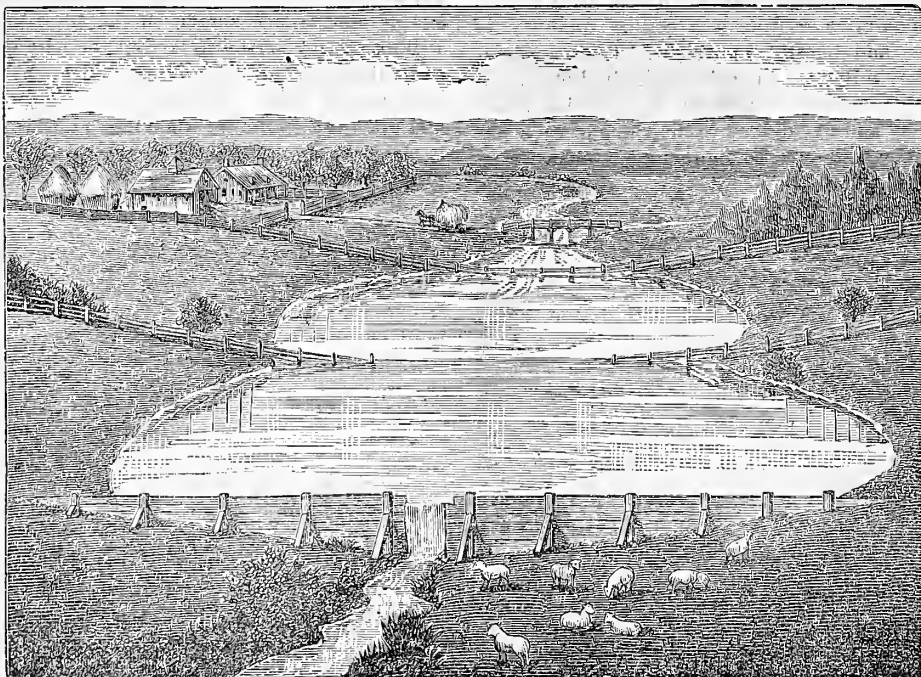

TEMPORARY DAM FOR ARTIFICIAL ICE-POND.

steamer in which the feed is cooked. It is well to have two steamers, so that one can be long, jointed and tongued and grooved upon their edges. These are fastened to the posts by

under-growth of woods should first be cut off close to the ground and piled in heaps for removal. They may be cut up if no larger than an inch in thickness, by a strong fodder-cutter, or a broad axe upon a block, into lengths of two or three inches, and used for fuel. Then the leaves may be raked up with a horse hay-rake into windrows, and then into heaps. They may be loaded up into hay-racks covered with barn sheets or blankets, with barley forks or by means of leaf-baskets such as is shown in the accompanying illustration. We have purchased these made of splints for 50 cents each; but have seen them made and used by charcoal burners for this purpose, of a stout hoop of hickory to which a piece of coarse bagging is sewn. This makes as good a basket for gathering leaves as any. It should hold about two bushels when heaped up. A wagon is soon loaded by their aid. When gathered they should be stored in a place where they may be kept dry, and if in good condition, a ton of mixed hard-wood forest leaves may be considered as well worth two tons of straw.

The Ecraseur.

Some time ago we referred to an instrument used in the operation of emasculation, by which it was rendered much easier of performance and perfectly safe. This very necessary operation on the farm is not done without a certain amount of risk and loss of stock, and an instrument by which it can be performed safely, is of great value to those interested. Since our reference to the écraseur, we have received numerous enquiries as to the mode of using it. This we now describe. The instrument, as shown in the illustration, consists of a tube in which a chain of plate links is drawn in or out by means of a screw at one end. The parts to be removed are laid open in the usual manner, taking care to make an opening at the lower part of the scrotum, so that in case of the formation of pus in the wound, it may escape, and

not become absorbed. The chain is placed around the gland, and the screw is turned until the pressure of the chain upon the cords and vessels causes its separation. The operation is then complete. The compression to which the vessels have been subjected, nearly always prevents all bleeding, and but a few drops of blood are lost in any case. The pain is reduced to a minimum, and the after operation of cauterizing is unnecessary. The time occupied is very much shortened, and generally the process of healing commences at once and goes on successfully. By means of the length and peculiar form of the instrument, it can be used when other means would fail. We believe that Prof. McClure, veterinary surgeon, of Philadelphia, is to be credited with the introduction of this instrument into our practice, and that Mr. D. W. Kolbe, of Philadelphia, is the manufacturer of them. A cheap instrument is made especially for the use of those who cannot procure the services of a regular veterinary practitioner.

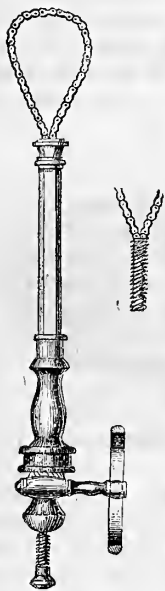

ECRASEUR.

A Farm Signal.

The following will be found a convenient method of conveying signals to distant parts of the farm, in place of the old-fashioned tin horn, the usefulness of which is confined to its one single unmelodious note suggestive only of dinner time. There are times when messages or instructions are to be conveyed, and it is not convenient to send a messenger. A visitor calls, or some business needs attention, and some one has to lose time to go to the farther end of the farm to convey the information. All these steps may be saved and the time also, by having a little code of well-understood signals, and a contrivance such as is here illustrated fixed to the gable end of the barn or the house. A short post is fastened to the end of the barn, passing through the roof. At the top of this post a wooden wheel is fixed, having two holes bored in the edge at opposite sides, and an arm projecting outwards from the edge. The wheel works upon a wooden pin driven into the post. A cord is fastened to each of the holes, and by pulling one or the other of these cords the arm is made to take any position desired. It may be held upright, or sideways, and level, upon either side, or pointing upwards or downwards upon either side. In this way seven different signals may be made. If more are needed there may be another wheel placed on the other side of the post, and seven more signals may be given. In this case each set of arms should be painted different colors. Red is the color that is most easily seen at a distance, and black would make a good contrast. In our own experience we have found that signals given in some such way are very quickly noticed, and when it is known that they are thus given the eye is very frequently cast in the direction to look out for them. A little red flag run up at dinner time or other times on the flag staff at the end of the house, never failed to

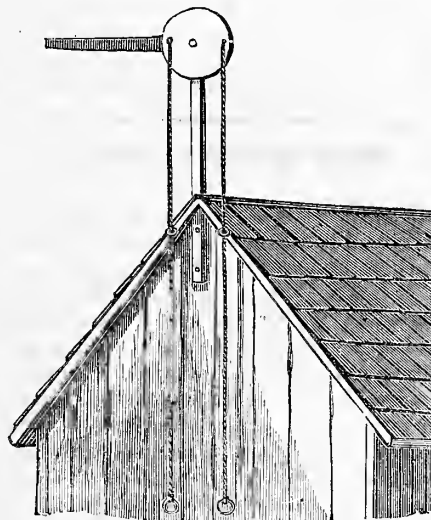

FARM SIGNAL.

bring us home within a few minutes, but in this case the signal failed to convey more than one message, and its meaning consequently was sometimes mistaken.

Method of Climbing Trees.

People who live in timbered districts frequently find it convenient to have some way of readily climbing a tree. In felling trees where timber is valuable, much damage and waste is prevented by being able to bring the

tree down exactly where it is wanted. To do this it is often necessary to climb the tree to be felled, and sometimes an adjoining one. In making surveys in wooded districts, or to get a more extended view in places that are only partly wooded, as in prairies made up of what

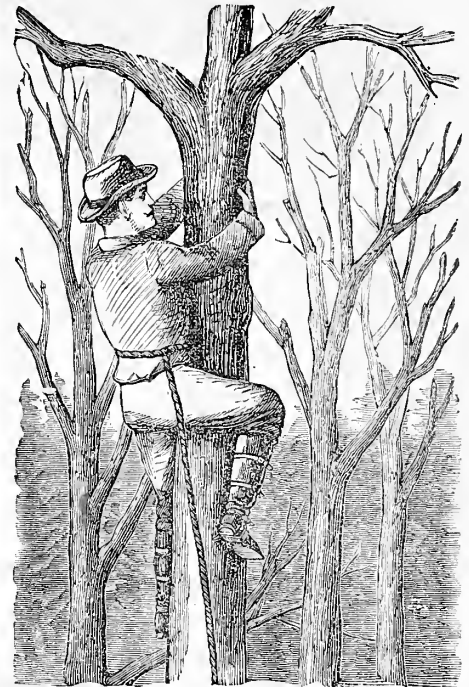

Fig. 1.—CLIMBING TREES WITH STIRRUPS.

are known as openings, where one has occasionally to hunt stray cattle, it is sometimes very necessary to get up a tree. This may be done very readily by procuring a pair of spiked stirrups like that in figure 2. It is made of a flat iron bar about an inch wide and a quarter of an inch thick, bent to pass under the boot in front of the heel, and made with loops by which it may be strapped to the leg. A sharp stout spur is fixed at the lower part, and when the stirrup is worn this spur comes at the inside of the foot. When a person wishes to climb a tree, one of the spikes is thrust into the bark and then the other, a step upward being taken at each time. A cord is carried around the waist, and if it is necessary to do any work while up the tree, the climber can pass the cord around his body and the tree, and make himself secure. The rope also answers to draw up tools or anything else that may be wanted. The method of climbing, by aid of these stirrups, is shown in figure 1.

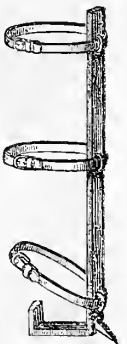

Fig. 2.

CEILED STABLES.—The usual method of ventilating stables beneath barns, is by allowing the foul air to escape through the hay and grain stored above the animals. This is objectionable for obvious reasons. Such stables with poles or rails for the floor above, are dingy, dark, and generally well festooned with cobwebs. Besides their disagreeable appearance, they allow the dust, chaff, and hay seed, to fall upon the backs of the cattle, and these are thus always kept unclean. Dark stables and coats matted with dust are not healthful for cattle, to say nothing of the deteriorated condition of the feed stored above them, which is exposed to all the foul air that rises from beneath. We greatly prefer to have the floor

above laid with matched boards, which will prevent any dust falling through, and to have the beams and under side of the floor white-washed. Ventilation may be provided by spouts through which hay or straw could be thrown down below, and which should terminate in grated openings beneath the eaves.

Aids at Slaughtering Time.

The slaughtering of hogs is one of the most disagreeable labors of this season. It is made much more unpleasant than need be by the complete absence of any organized methods of going to work. Generally it is postponed to the latest moment, notwithstanding the fact that the earliest pork in the market rarely fails to bring the highest price of the season, and also that the colder the weather is, the less rapidly a hog fattens. As a rule, this business ought to be over before the winter has commenced, so that the pork may be made as cheaply as possible, and the slaughtering may not be more disagreeable than necessary. When a hog is to be killed, the first job is to catch him. This is very easily done by the use of an implement shaped somewhat like a shepherd's crook, shown at figure 1. The handle of this should be about five feet long. The animal is caught by any part of one of the hind legs, and the noose in the looped rope shown at fig. 2, is slipped over the

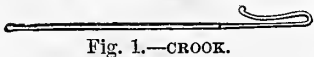

Fig. 1.—CROOK.



Fig. 2. NOOSE.

hook of the other one. He is then led to the slaughtering place or slaughter house, where by means of a hoist, the hook of which is placed in the loop of the rope, the animal is raised in a moment to a height that brings him into a convenient position for the butcher. The blood may then be caught in a barrel or other vessel, and made use of in the manure heap instead of being wasted upon the ground as is usual. The animal is then lowered into the scalding-tub shown at fig. 3, which should be kept close by, and when ready is hoisted out and lowered on to the seraping-table. This, which is shown at figure 4, is made of bars of wood fixed in a frame so that all the water and hair drops through into a heap, from which they may be easily removed. A scraper which we have found very useful is shown at figure 5. It is made of a piece of seythic bent into the shape here shown, and fastened by means of tangs made at each end into a wooden handle. With this the hair is removed with great ease and rapidity. The animal is then hoisted once

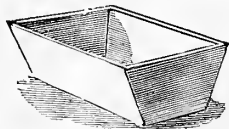

Fig. 3.—SCALDING-TUB.

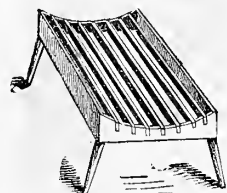

Fig. 4. SCRAPING-TABLE.



Fig. 5. SCRAPER.

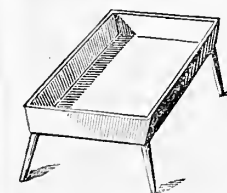

Fig. 6.—TUB ON LEGS.

more over a wheelbarrow, or a square tub set upon legs as shown at fig. 6, into which the offal is received. The offal is thus kept clean, and the lard may be removed without being soiled. The whole arrangement is very simple, and one that may be modified to suit any circumstances.

more over a wheelbarrow, or a square tub set upon legs as shown at fig. 6, into which the offal is received. The offal is thus kept clean, and the lard may be removed without being soiled. The whole arrangement is very simple, and one that may be modified to suit any circumstances.

How to Make a Halter.

A very serviceable halter is here shown. It may be made for a few cents, and in a few minutes, out of a piece of leather, a buckle, and a few copper rivets. It may also be made of rawhide that has been well worked in oil and rendered pliable and soft. The safest way of fastening an animal is by means of a halter. To fasten a horse or a cow by a rope around the neck is to invite an accident by which the animal may be injured or even lost. Calves, colts, cows, and horses, should all be secured with halters, to which is attached a rope weighted at one end, passing through a ring bolt securely fastened in the stall. It is almost impossible for an animal fastened in this manner to get thrown, and if such a thing should occur it will not get choked as when fastened by a rope around the neck. To make the halter, it is only necessary to measure the animal with a tape-line to get the proper length of the separate pieces, and to cut the strips at least 1½ inch wide, and 2 inches wide for horses, oxen, or cows. If the halter is needed extra strong, it may be made double, and the strips held together by a few copper rivets and burs. For the cost of a few dollars every animal upon the farm may be supplied with a secure halter. The pattern of this halter is sufficiently given in the illustration without further description. The rings there shown may be omitted, and the strap under the jaws may be made to directly connect the nose-band and the throat-strap.

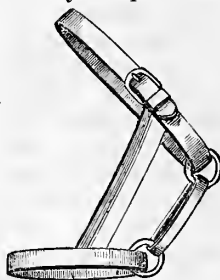

HALTER.

The pattern of this halter is sufficiently given in the illustration without further description. The rings there shown may be omitted, and the strap under the jaws may be made to directly connect the nose-band and the throat-strap.

Sheep Raising in Virginia.

Lying west of the valley of the Potomac, there is a broad belt of poor land stretching nearly to Gordonsville on the west, and almost to Richmond on the south. This region is crossed by the Orange and Alexandria Railroad, and the Chesapeake and Ohio. For eighty miles southwest of Alexandria, the country is desolate, the depots are few, the villages small, the farm houses very scattering and poor, much of the land is without fences, and growing up to brush and forest trees. There is hardly a good piece of corn in sight of the railroad from the valley of the Potomac to the Rapidan. The principal timber in this region is oak, poplar, or whitewood, paw-paw, and pine—of small growth. The district has never been thickly peopled, as the census returns show. There has been no increase in population since 1800, and a very steady decline since 1830—some of the counties having lost from one-third to one-half of their population. Land in forest can be bought for five or six dollars an acre, and old fields with buildings for about the same price, or a small advance. In a recent trip from Washington to Richmond, we passed across this district by way of Gordonsville. We learned from an intelli-

gent farmer who lives upon its outskirts, that the region produces cattle, swine, and sheep, but is generally a poor country, quite unprofitable for ordinary farm crops. He was a Virginian, working a 400-acre farm, and making it pay reasonably well. He had a well digested plan for raising sheep which is applicable to this whole region, and, if anything can be done to redeem this waste from its present desolation, it is sheep husbandry that will do it. There is no doubt that good farms can be made in this region by large expenditures for manure and labor, but the problem to be solved is to make the products sold pay for the improvement of the land, and the capital used in the improvement. The great objection to raising sheep in Virginia is the destruction of flocks by dogs. He would remedy this objection by keeping a shepherd to give his constant attention to the flocks, and fold them at night. Nearly all the damage caused by dogs is done at night, and if the flocks were folded securely then, there would be no loss. Sheep in fair condition can be bought in this region for about a dollar and a half a head. He would buy 200 ewes in good breeding condition, for say \$300, and four Cotswold rams for say \$100, making an outlay of \$400 for his flock. He would put the rams with the flock Sept. 1st to bring early lambs. Sheep do well in these pastures until late in December. As soon as snow begins to fly he would feed with hay, straw, turnips, and as the sheep approached yearning time, would add meal or grain. He would have a piece of winter rye ready for them to feed upon early in the Spring. By the time the rye was gone, the pastures would be green, and the sheep would take care of themselves. Sheep thrive very well in the climate of Virginia, and the excess of births from twins, he calculated, would make the lambs equal the number of ewes kept, if there should be occasional losses. There is a ready sale in the Washington and Baltimore markets for all the fat sheep and lambs that can be raised. He would send his lambs to market in May and June, and get for them by the wholesale an average of \$3.00, say 200 lambs, \$600. The ewes he would sell in July and August as fat sheep at \$3.50 each, say \$700. He would get at least \$1.00 worth of wool from each sheep, making \$200 for wool. The receipts from the flock for one year would be \$1,500. He would then buy another flock of 200 ewes and begin the year again September 1st. He calculated the sheep would benefit the pastures enough to pay for their keeping. The small plots where they were hurdled at night would be made very rich, and bear large crops of turnips, rye or hay. The principal expense would be the wages of the shepherd, and not more than half his time would be required in the care of the flock. From what we have seen of the influence of sheep in pastures, we have no doubt of their great value in improving the soil, and of their special adaptation to these old fields in this district. There are large tracts of lands, like these, in all the older States, that can be made valuable by sheep husbandry. The country needs more wool, lamb, and mutton.

The Pekin Ducks as Layers.

The sensation made last fall among the fanciers at the poultry exhibitions, by the extraordinary size of these new ducks, is likely to be equaled this season by their remarkable record as layers. Two of the imported birds

last year laid respectively 125 and 131 eggs. They have done much better the present season. One of the old birds commenced laying on the 27th of February, and laid 178 eggs in 182 days, missing but four days. The other did nearly as well. This is three or four times as many eggs as we ordinarily get from Rouens or Aylesburys. What is more remarkable, one of the young ducks, hatched in April, began to lay in August, and had laid seven eggs by the 1st of September. Such early laying is all that we expect of the best varieties of gallinaceous fowls. The Pekins as much excel in fecundity all other varieties of ducks with which we are acquainted, as they do in size. They have had the advantage of thorough breeding for centuries for their flesh and eggs, and we predict for them in this country the front rank among our useful aquatic fowls.

A Rat-Proof Fence.

Granaries, corn cribs, or poultry houses, may be made rat-proof, by means of a wire fence which we here illustrate, and for which we are indebted to the *Journal d'Agriculture Pratique*, of Paris. This fence has been introduced with perfect success, into the Garden of Acclimatation in Paris, for the purpose of preventing the depredations of rats. No rat can surmount this fence. It is made of thin wire bars placed an inch apart, and affixed to heavier cross bars; the ends of the bars being curved outwards, as shown in figure 1. When the building to be protected is placed upon the ground, and it is desired to prevent rats from undermining it, two rows of bricks or tiles are placed beneath the fence, one in an upright position, and sunk a few inches beneath the surface, and the other horizontally and projecting outwards, forming a bench. When the rats dig down to burrow beneath the building, they follow the first tile until they meet the second. Being stopped here, they burrow along the angle formed by the two tiles until they are tired, without being able to penetrate beneath the

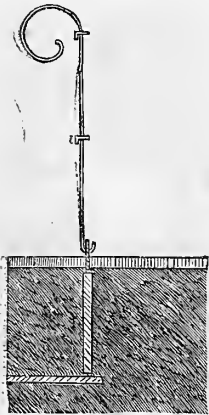

Fig. 1.—END OF FENCE.

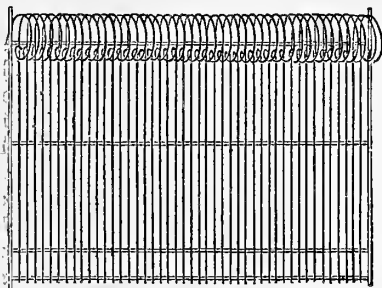

Fig. 2.—FENCE COMPLETE.

building. If they attempt to climb the wires, they get into the gallery formed by the upper curve, but can go no further. The fence of course is made of such a height that a rat can not leap over it. In the Garden of Acclimatation, the fence is about two feet in height, and is found perfectly effective. Figure 2 shows a piece of the fence complete. This contrivance

is also used to entrap rats, which it does in large numbers. A small park or enclosure is surrounded with this fence, protected at the bottom with tiles as already explained. An opening is made, by which the rats may enter but can not return. Seeing a possible escape by means of the fence they enter readily, but once within they discover that some men know more than a rat. There are many modifications of this simple contrivance, which will doubtless occur to our readers, by which farm buildings, grain stacks, and other places which suffer greatly from rats, may be made secure from their depredations.

PREPARING POULTRY FOR MARKET IN FRANCE.—In the vicinity of large towns in France, millions of fat chickens or capons are sent to market every year, an enormous supply going constantly to England. When the fowls are put up for fattening, they are fed almost entirely on crushed millet, or barley, (or a mixture of the two,) kneaded into a tough dough, to which a little butter or lard is added. Their drink is usually pure milk slightly sweetened with sugar; sour milk with sugar is frequently substituted. By means of this nourishing diet the fowls acquire a delicate, white, and savory meat, and become fat in an incredibly short time—often in ten days. Fat poultry is never sent alive to market. Capons, chickens, and pigeons, are bled at the throat, hanging head down until all the blood has escaped. Geese and ducks are killed by a stab in the nape of the neck. The feathers are picked off with great care to avoid injury to the skin, and after the fowls have been washed clean, they are well rubbed with wheat bran, which whitens them; the butchering is done at night, and they are hung up with a few raw truffles in each body; in the morning these are removed, having given a delicate flavor to the flesh.

Native Breeds of Sheep.

The United States possess every facility and requisite for the production of a great variety of sheep. Instead of importing wool of any kind, with our splendid facilities for producing both cheap and costly wool, we ought to export more than any other country. There are some coarse wools cheaply produced that may be made more profitable with us than the fine wools, yet we are trying to raise foreign breeds of sheep that deteriorate rapidly under the process of acclimation, and qualities of wool that are not in demand. Many a farmer has found the few fleeces of Cotswold or Leicester wool that he has had on hand almost unsaleable, because no country mill had the machinery for carding long wool. At the same time our markets are flooded with the poorest kinds of mutton, oily, greasy, and fat, or ill-flavored and lean, because farmers have been tempted to raise sheep for which their pastures are totally unsuitable. Before there can be any success in this business, it must be entered upon and carried on with judgment. No farmer who has not the best facilities both for feeding and marketing sheep and disposing of the wool, should try to raise pure Cotswold, Leicester or Lincoln sheep, especially the latter two. Indeed, these sheep do not seem to be profitable under any circumstances, except in the hands of the most skillful shepherds. The

Cotswold grades, or Cotswold-Merino crosses, furnish the best early lambs and the best mutton for the markets of large towns and cities. But early lambs cannot be shipped long distances, and farmers situated more than 200 miles from a good market cannot raise these lambs for that purpose. Where lambs and mutton are produced, wool becomes a secondary consideration, but where long wool can be sold readily the larger bodied sheep which yield a fleece of 8 or 9 pounds of wool will be the most profitable under certain conditions. And this is the most important consideration. To raise these sheep successfully, the pastures must be dry, healthful, fertile, and carry a good bite, and the soil and its culture must be such as to produce heavy crops of roots and green forage. It would be all the more satisfactory if the climate were such that late feeding upon rape, turnips, or other roots, upon the ground, and early feeding upon rye, clover, and other green crops could be practiced. This would enable the farmer to make a great saving, and yield a proportionately larger profit than the yard feeding through half the year upon crops harvested and stored at great cost. For instance, in the greater part of Virginia, parts of Tennessee, Kentucky, Maryland, and some other localities, similarly situated with regard to climate, the hurdling of sheep upon green or root crops might be practiced to a large extent, and the cost of their feeding reduced to a minimum. Under these circumstances the Cotswolds might readily be made the basis for a very profitable class of sheep, different varieties of which might occupy different localities as became the most suitable. But it will surely result, that there will be failure and loss, if in all localities, however diverse they may be in soil, climate, and other important conditions, the endeavor is made to keep up and produce any one particular type of sheep. In other places in the East and North, where hurdling cannot be practiced, the extra price to be procured for early lambs and choice mutton in the great city markets, will make the house or yard feeding of sheep upon crops grown on richly manured land equally profitable. But there are many localities still where it is difficult to keep sheep that require abundant pasture and roots for winter feed, but where mutton may yet be raised with profit.

In many parts of Europe sheep are raised upon mountains that are aptly styled barren wastes, and salt marshes and sandy plains, where one of our native sheep, much used to hardship as it may be, could not exist. Yet the mutton of some of these sheep is sold at stores where fancy fruits and choice articles of food are kept, as an expensive luxury. The small Welsh sheep, whose hind quarter of the most delicate mutton may weigh four to six pounds, is fed upon rocky pastures as bleak as the sides of the granite mountains of New Hampshire; while an equally choice mutton, to the epicure, is raised in the salt marshes of the coast upon sedges and rushes. The chalky downs of Southern England, where the soil is too thin upon the chalk rocks ever to be plowed, produce the South Downs and the Hampshire Downs, whose mutton is very highly prized, and whose fleece, although short is thick, and valuable for manufacturing.

The vast prairies of the West furnish exactly the conditions needed for these races of sheep; a short nutritious herbage, a perfectly dry soil, extensive open areas, and the most salubrious atmosphere, ever fresh and invigor-



PORTRAITS OF HORSES OF VARIOUS BREEDS. — Drawn and Engraved for the American Agriculturist

ating, and dry for the greater part of the year. These races of sheep also seem fitted by nature for those Western pastures. Their hardy constitutions, and their close compact fleeces, impenetrable by storms either of snow, rain, or wind, render them able to withstand with perfect ease those sudden but short periods of more than usual severity which sometimes occur. There are also the black-faced Scotch sheep, which would be perfectly at home upon the most northerly of the Western prairies. Western Kansas and Nebraska possess millions of acres which can be purchased for a nominal price that should never be disturbed by the plow, but should be populated by thousands of flocks of sheep who would there find a convenient and congenial home. From thence the wool and mutton could readily be transported to profitable markets. Further West still the range can be occupied by sheep whose wool alone should be the object of the shepherd. In each of these localities in course of time there could be built up a race of sheep eminently suited to its peculiarities, but the founding of such races will be the work of time, and to a great extent, a labor of love with some persons who must be devoted to this employment, and who, although "there's money in it" from the

first, will yet look for their most abundant reward to the general improvement of this important branch of American agriculture.

Various Breeds of Horses.

There is no domestic animal which has become more thoroughly adapted to the various needs of mankind than the horse; at the same time there is none of which a greater variety is more demanded to suit our various necessities. The road-horse and the farm-horse must necessarily be as distinct from each other as the work required of each is different. In the above illustration the different varieties in use with us, together with their several peculiarities, are shown at a glance. At first we have the thoroughbred, the source from which our road-horses derive their speed, courage, and endurance. In this breed great speed has been acquired by many years of care in breeding by selections from the Arab race, (shown on the opposite corner of the engraving), and by a long course of training. From the thoroughbred we have derived the pacer and the trotter. It may be thought that these animals have their chief use on the trotting track, and are therefore of

little account for practical purposes. There could be no greater mistake. The trotter has rightfully a large place in the agricultural interest of the country, for there is an immense and increasing demand for these horses for driving purposes at very profitable prices. The breeding of such horses, however, demands large capital and much skill, and is a business that requires undivided attention. The two choicest breeds of farm horses are seen at the lower corners. The Clydesdale and the Percheron breeds promise to give us a valuable class of heavy, powerful, and most useful animals, which are indispensable to the proper cultivation of the soil. The Percheron is rapidly rising in favor, and if care is used in procuring pure-bred animals, the breed will undoubtedly be a most valuable acquisition. The semi-wild races too, the Mustang of the Plains and the miniature Shetland, of the Scotch islands, deserve notice. The first is the hardiest and most useful animal that the Western herder can choose for his severe service, while the latter occupies a place as a pet for children, which no other variety of the horse can fill. The heads grouped in the center well express the intelligence and the gentleness of this, our most valuable and willing servant.

The Rose-Mallows—Hibiscus.

In another article we have mentioned some of the Abutilons; another ornamented genus of the Mallow Family, is *Hibiscus*, of which a hardy shrubby species (*H. Syriacus*) is well

6 or 8 inches across. Our plants produced flowers scarcely more than half that size, which is probably in part due to the severe drouth, and in part to the fact that the plant does not bloom until late, and the cool nights check its development. By the time it is well in flower,

upwards, or it may be pruned to a clean trunk, with a tree-like head at any desirable height. This tree form is very effective when planted out on the lawn in summer, and it is well adapted for the window, as its head can be quite above the lower growing plants. Another



SCARLET ROSE-MALLOW.



ABUTILON—BOULE DE NIEGE.

known as the Rose of Sharon, and a tender shrubby one is the Rose of China, (*H. Rosa-Sinensis*) of the greenhouses. Most of the species are herbaceous, known as Rose-Mallows, and a number of showy ones are natives of this country. Late in summer the brackish marshes along our rivers, are gay with the large pink hollyhock-shaped flowers of the Swamp Rose-Mallow, (*H. Moscheutos*) a species which does well in gardens, and is worthy of a place there. Farther South and West, there are several other species, all showy and desirable in large gardens; one of these (*H. grandiflorus*) has rose-colored flowers with a deep red center, which are sometimes a foot across. The most brilliant of all is the Scarlet Rose-Mallow, (*H. coccineus*), a strictly Southern species, which is found in marshes from the Carolinās, southward and westward. We had long known this plant from herbarium specimens, and were glad to receive this spring some roots from Dr. Lungren of Florida, which enabled us to see it growing. In its native localities this forms stems 4 to 8 feet high, but ours only reached about the lesser height, it is very smooth throughout, and has large long-petioled leaves, which are parted quite to the base in five divisions; the flowers, which are abundantly produced from the axils of the upper leaves, are bright scarlet, and when growing wild are

it will no doubt be cut down by the frost, but it is such a showy plant that it is worth growing, even if it can be enjoyed for but a short time. We doubt if the roots will endure the winter, but shall try some and take the others to the cellar.

Abutilons—Boule de Nieve.

Among the many ornamental plants afforded by the Mallow Family, the Abutilons take a high rank. One of these, *Abutilon striatum*, has been a long while in cultivation, and is now quite common under the rather absurd name of "Flowering Maple," no doubt so called from the resemblance of the leaves in shape to those of the maples. This is one of those plants that satisfy the most exacting grower, as it will bloom all the year round; it is easily managed as a window plant, and when set out in the garden in summer, it proves attractive there. The principal objection to it as a window plant, is its tendency to grow out of bounds, and as many cultivators are too fond of their plants to use the knife to them, we often see this grown out of all proper shape. No plant more needs judicious pruning, and none repays it better than this; it is so very tractable that it may be made to assume any desired form, and may be grown as a pyramid, well furnished with branches from the base

reason for its popularity is the ease with which it is propagated, cuttings of the half hardened stems taking root readily. The fine clean handsomely shaped leaves of this Abutilon, together with its gracefully pendulous, bell-shaped, curiously veined flowers, make it a very desirable plant. A variety with the leaves handsomely blotched with golden yellow, is one of the few variegated plants that are satisfactory at all times. This, which is called *Abutilon Thompsoni*, is equally manageable with the plain form, and whether grown in-doors with partial shade, or out in full sun, its markings are clear and brilliant; this form does not flower so freely as the plain. Another species, *A. venosum*, has larger and darker flowers than *A. striatum*, but is not so well calculated for window culture. Between these two there are several hybrids with florist's names. These plants are very useful in greenhouses and conservatories, for training up to pillars or against walls, they bear pruning so readily, that they may be made to adapt themselves to either place. Last spring we received from Mr. John Sanl, of Washington, D. C., a quite new Abutilon, under the name of *Boule de Nieve*, or "snow-ball," which, as its name would imply, originated in France, and the shape of its leaves, as shown in the engraving, indicate that it is from a species quite unlike those just referred to. The flowers are pure white, and of good

form; the little plant sent us grew rapidly, and flowered very freely, and should it retain these qualities when taken in-doors, it will prove a very valuable winter bloomer. White flowers of the size of these are in great demand by the bouquet makers, and this abutilon will no doubt be found profitable to those who grow cut-flowers for sale. It blooms when quite small; plants from cuttings flowered with us when only a few inches high.

Heating Greenhouses by a Flue—A probably New Method.

BY PETER HENDERSON.

While in Philadelphia a few weeks ago, I called on William K. Harris, Darby Road, West Philadelphia, having been informed that he had a system of heating his greenhouses by flues somewhat different from that in common use. I found his method not only entirely new to me, but also one that I think is destined to be of great benefit to those who do not wish to go to the expense of heating by hot water, as Mr. Harris' plan is certainly the next best thing to it. He showed me one building 100 feet long by 20 feet wide, which he assured me was amply heated by one fire only, allowing him to keep up a temperature of 50° over all parts of the house in the coldest weather. The furnace is built at the middle of the house, as shown in the accompanying sketch. The bars for the grate are 40 inches long, and enough of them to make a width of grate of 18 inches. The sides of the furnace are built of fire brick to a height of some 15 or 18 inches, over which is thrown an arch in the usual way. From the neck of this furnace or "fire box," proceed two flues, one turning to the right, the other to the left; these are built of brick so as to form a flue of 8 or 9 inches square on the inside. The brick part of the flues only runs 25 feet each way from the furnace, and from that point they are formed of 8-inch cement drain-pipe. Where cement pipe cannot be obtained vitrified, other kinds would do nearly as well. The brick part of the flue, as well as that formed by the pipe, is raised from the ground, on brick or flagging, so that it is kept free from damp, and that the radiation of the heat may be obtained from all sides. As will be seen by the sketch, the flues are so built as to be under the centre or middle bench; each flue forms a length of

the long length of flue could get around, and hence our experience in long horizontal flues of a "bad draft." By this ingenious plan the draft is made perfect, and a thorough radiation of heat from the flue in all its length is secured.

Mr. John Dick, (a neighbor of Mr. Harris), who probably has the largest area of greenhouses on the Continent, and which are mainly heated by double flues as in Mr. Harris' case, says that he never before saw or heard of this plan of starting the chimney on the furnace, so it would appear that Mr. Harris has the honor of the invention. Mr. Dick attaches great importance to it, and probably no man in the country has had better opportunities of knowing or better able to judge than he. The cost of a flue so constructed would probably not exceed \$200, while for the same glass structure, if heated by hot water, the apparatus would cost not less than \$1,000. This system of double flue would be equally applicable to a greenhouse of half the length, the only difference being that a furnace bar of 24 or 30 inches would be enough, and the area inside of the brick flue and pipes need not be more than 6 inches. It is necessary to take great care that both flues start from the furnace and be continued exactly at the same level, otherwise the higher one would draw the heat away from the other.

Notes from the Pines.

When I sent you twenty odd varieties of grapes, that you might see what could be done on my light, sandy soil, what did you do? Instead of eating them "judgmatically" and comparing one with another, you set the whole lot in the window with, as I learn, a placard, "Grapes from the Pines!" Of course all the passers on Broadway looked at the grapes, and the tens out of the hundreds and thousands who saw them, were sufficiently interested to ask questions. As a consequence of this publicity, I am asked among other questions: "What is the best grape?"—"What grapes shall I plant?"—"Where can I get vines of?"—this, that, or the other kind. The best way to satisfy these questions is in print, and if my "Notes" are this time

ALL ABOUT GRAPES, you have only yourselves to blame for putting my products in so conspicuous a place. To begin at the other end, and answer the last question first, as to

WHERE TO BUY VINES.—It is safe to say that every grape worth growing, and that will succeed, east of the Mississippi, can be had of any regular nurseryman. The advertising pages of your paper give the cards of numerous dealers, and

for any grape that people in general need to plant, these nurserymen can supply them. All the varieties I exhibited are in all first class nurseries; I have more than twice as many varieties as I sent, some not in bearing; some have borne, but if I have my way they never will again, at least not in my vineyard. Some grapes cannot have their merits tested in one or two years, while others are so undeniably bad that their fate can be decided at once. The question

"WHAT GRAPES SHALL I PLANT?" is an easy and a difficult one to answer. If one wishes grapes and a plenty of them, without being very particular as to quality, and if he thinks he has done his whole duty when he has

set his vines and given them something to run upon, let him by all means get the Concord. I of course do not refer to the far Southern States, but east, and west, and north of Georgia, this is thus far the universal grape. Although of Eastern origin, the farther west it is grown, anywhere this side of the Rocky Mountains, the better it is. In New England it is eatable, in Ohio it is good, and in Missouri it is so much better as to appear unlike the same grape. When we leave the Concord, telling people what grapes to plant is a risky matter. I see such a difference in localities close to one another, and such a difference one year with another in the behavior of the same varieties, on my own grounds, that I should hesitate to make out a list of six kinds for my next neighbor. My little vineyard is essentially an experimental one for my own instruction. The soil, so far as I can see, is alike all over the piece, and no fertilizer has been used save one or two light dressings of bone. I have one Salem vine that gives a good crop of good fruit; 25 feet from it is a Salem, two years older, that has never borne a berry. Last year, and year before, the Croton was splendid, this year not worth picking; this year the Ionas are very fair, the only crop in three years, and so it goes. Many varieties behave in such an unreasonable manner, that the experience of one year is no indication as to what they will do next. But one thing I do know: you may go to my Concord vines any year with a wheelbarrow, while to most of the other sorts a hand-basket will suffice. My own experience makes me hesitate when asked what grapes to plant. To the question

WHAT IS THE BEST GRAPE, I can only answer the inquirer: "The best is the one which will grow on your place and give you fruit." If the question refers only to quality of fruit without regard to the difficulty or uncertainty of producing it, my choice would not suit the majority. I like a high vinous flavor in a grape, while most persons look for sweetness. To my taste the choice would be between the Alvey and Senasqua, while 19 in 20 would prefer the over-sweet and cloying Delaware to either. Perhaps I can make my experience of some use to inquirers, by giving my opinion of the leading varieties as they behave on my place. When I procured the vines four and five years ago, I selected those kinds which were for the most part but little known, although none are rare at the present time.

Alvey.—Quality exquisite, but bunches usually poor.

Agawam (Rogers' 15).—Hardly worth growing.

Black Hawk.—Great earliness was claimed for this seedling of the Concord. With me it is not early, and not good for anything when it does come—worthless.

Barry (Rogers' 43).—This is earlier than the Concord, larger berry, good bunch, and a much better grape. This has so many good qualities, the vine being as healthy and hardy as can be, that I am surprised no more is said about it. It would bring a much better price in the market than the Concord, and for home use it is greatly preferable.

Canada.—Neither this nor the others of Mr. Arnold's varieties have done well with me.

Creveling.—This excellent early grape has not failed to give a good crop. The small and irregular bunches, which unfit it for market, are not objectionable for home use.

Croton.—It is already been stated that this

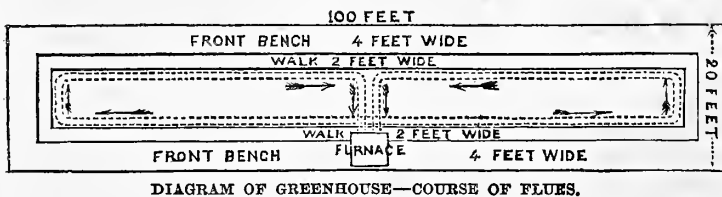

DIAGRAM OF GREENHOUSE—COURSE OF FLUES.

about 100 feet in this distance; the "rise" should be about 1 foot in 100—that is, the point where the flue starts from the neck of the furnace should be one foot lower than where it enters the chimney. The novelty of this manner of constructing a flue consists in building the chimney directly upon the top of the furnace where the two flues, after running for a length of a hundred or more feet each, (as shown in the sketch), enter it, and this method of placing the chimney on the furnace is the key to the whole improvement—the continued heat given out by the furnace is sufficient to drive back the cold or outer air that would necessarily force its way down the chimney before the heated air running through

quite failed this year after two seasons of most satisfactory performance.

Delaware.—I am surprised that this should do so well upon my light soil. It is one of the varieties that will bear feeding, and when the vine gets age it bears abundantly. It is the favorite with most persons, on account of its intense sweetness.

Essex (Rogers' 21).—An exceedingly rampant coarse vine, with large brownish berries in loose bunches; quality inferior. With me not worth the room it occupies.

Eumelan.—I set out some 15 or 20 vines of this when it first came out. Perhaps one half of these are scarcely larger than they were at the end of the first season; some of the others have done fairly, while five or six are magnificent vines bearing all that a vine ought to bear; and this happens with vines which were apparently alike when planted, and with those that are side by side in the same row. Mr. Meisner, of the great grape growing establishment of Isidor Bush, Son & Meisner, Bushburg, Mo., was here a few days ago, and in discussing varieties, I asked about the Eumelan in Mo. He gave it high praise in every respect, except in the one just mentioned—the uncertainty attending the growth of the vines. My laggards will come out this fall, and I will see if there is anything the matter at the roots. As to the fruit itself, I do not think too much can be said in its praise. The bunches are well shouldered, with a fine bloom, and as to quality, but few American grapes can equal it. When these and Black Hamburgs are upon the table at the same time, I taste of the Hamburgs and eat the Eumelan. If it were not for the uncertainty above mentioned, I should advise every one to plant the Eumelan. It mildews, and so do almost all good grapes, but I do not fail of a crop.

Hine.—A little known variety, which as to its fruit, might be readily mistaken for the Delaware. The bunch is looser, the berry a trifle larger, and to my taste a better flavor.

Iona.—Too uncertain to commend, but fruit of the first class when you get it.

Ives.—This is absolutely worthless with me. Vines out five years, and not a berry but has cracked, mildewed, rotted, or done something unpleasant. Yet, westward it is certain beyond all others.

Lindley, (Rogers' 9).—Very sweet and fair quality, but fruit drops badly.

Martha.—This bears well enough, but that persons who have ever tasted a good grape, can eat this, is quite beyond my comprehension.

Salem.—Rather uncertain. Large and sweet. Does worse with me than on better soil.

Senasqua.—Late in ripening, but of the highest quality to those who appreciate life and brilliancy in a grape.

Walter.—Does nothing with me, vine four years old, and not a decent bunch yet.

Wilder, (Rogers' 4).—What I have said of Barry, will apply to this; it is a week or more later than the Barry, and a larger bunch. This year some of the berries have dropped, but as they did not do so in former years, I attribute it to the long drouth. This is a wonderfully showy and attractive grape, of better quality than the Concord, and every way to be commended for beauty, productiveness, and vigor. If I were intending to raise grapes for market, I should make a trial of this and Barry,

Dreer's Improved Lima Beans.

Lima beans are a rather troublesome vegetable to prepare for the table, on account of the difficulty of shelling them; their pods do not open so readily as those of other varieties, and the operation requires strength of thumb nails as well as patience. In the ordinary Lima there is a great waste of pod; the beans are set wide apart, and the pod is often so constricted that the halves touch between the beans. A large pod will frequently have but two, or at most, three beans, but this can be improved by selecting for seed, only those pods which have four (or more if possible) beans in them. The Lima is a distinct species (*Phaseolus lunatus*) from the common bush and pole beans, (*P. vulgaris*), and shows very little disposition to depart from its natural condition, or as the gardeners phrase is, it will not "break" readily into varieties. Some years ago one of our Western friends made many experiments, with a view to producing a low growing or bush Lima, but when we last heard, he had not succeeded in overcoming the disposition to go to the top of a tall pole. A few years ago Mr. Henry A. Dreer showed us some Limas which he considered a great improvement upon the ordinary kind, and this year we received from his son a basketful of the same beans for trial. We learned that this variety is the result of a careful selection carried on for some 20 years. In these beans the pods are not only full, with no spaces between, but are as full as they can stick, the seeds so crowding one another, that the ends of the central beans are square; the bean is also much thicker than the ordinary; the two engravings of both kinds given on the next page, do not exaggerate the difference in this respect. A vine of this kind bearing the same number of pods as one of the ordinary kind, would, we should judge, yield nearly if not twice as much in shelled beans. It is stated that this variety is much more productive than the ordinary, yielding many more pods to the pole. The pod being so completely filled, the shelling becomes an easy matter, and the beans when cooked are much superior to the ordinary ones, as the amount of skins is much smaller in proportion to the enclosed nutriment. We regard the improving of this bean as one of the most important of the recent contributions to horticulture. We take quite as much, if not more, interest in a new variety, or the improvement of an old variety, of garden vegetables, as we do in those among fruits and flowers. And he who makes three Lima beans grow where there were only two before, is entitled to quite as much credit as one who produces a coleus with a new stripe in its leaf, or a strawberry a trifle larger than any other, and horticultural societies should offer equally large premiums for improvements in the one class, as in the others.

BUYING AND PLANTING BULBS.—Whatever other spring flowers we may have, bulbs are essential, and the garden would hardly seem complete without its array of Hyacinths, Narcissuses, and all the rest of the bulbs, which unite beauty, brilliancy and fragrance, as do no other plants. October is the best month for planting bulbs, as they then have time to form roots before cold weather sets in; still we have had very satisfactory results from planting in November, and have known them to be put in as late as January, by taking advantage of an open spell.—We would much rather take the

risk of late planting than be without their flowers in spring, and those who have neglected or omitted to provide a stock of bulbs can yet do so, even at this late day. There are some who give special attention to these plants, and they are always on the lookout for novelties; such persons need no advice from us. But to the majority, especially those of moderate means, a hyacinth is just as welcome without a name as with, provided it be of good form and pleasing color. Unless one cares for the named varieties, much more satisfaction may be had for the same money by leaving the selection to the dealer, merely indicating the colors desired, and their proportion. We have had very good results from the assorted bulbs which are sold at much lower rates than the named ones. By sending to a dealer for his catalogue, the price can be readily ascertained. Another advantage in getting catalogues is, that they give all necessary directions for cultivation, and besides being a price-list, the catalogue of the present day is a clever little handbook of culture. We do not know how a few dollars can be more satisfactorily invested for the garden than in bulbs.

HYDRANGEA PANICULATA GRANDIFLORA.

The Horticulturist a few months ago made the announcement that this is a meritorious shrub, and apparently thinks it has made a new discovery. In its edition it says: "It is now about six years since its first introduction into this country, and yet only within two years has it been brought forward with much notice; nor do we remember ever seeing it illustrated in the 'high art' pictorial agricultural journals." We do not know if the Horticulturist classifies the *Agriculturist* among the "high art" pictorial agricultural journals" or not, but this Journal "illustrated" this Hydrangea in April, 1868, from a living specimen. We admit that the art of "Pictorial Agricultural Journals" is not quite so "high" as that of the Horticulturist, as we never knew one of them to publish an illustration of the Crystal Palace at Sydenham, and try to make people think it was a view of Kew Gardens.

GREAT YIELD OF RHUBARB OR PIE PLANT.

—A truck farmer near Providence, R. I., sold in that market the last spring and summer nine tons of Myatt's Linnæus Rhubarb from a quarter of an acre of land. Owing to very sharp competition he only received twenty-five dollars a ton for it, or one cent and a quarter a pound. This is \$225 worth of truck from a quarter of an acre, or \$900 per acre. If it had not been for competition, and the rhubarb had been sold at former season's prices, he would have received at the rate of \$1,800 an acre for this crop. This is by no means an unparalleled return for such farming. It is a result of a very liberal use of manure and labor, and of adapting crops to the wants of the market. A farmer uses fifty dollars' worth of manure and thinks he is very extravagant. A market gardener uses two hundred dollars' worth on rich land, and regrets that he had not put on more.

How to Grow Cauliflower.

BY PETER HENDERSON.

There is perhaps no vegetable we cultivate that is so uncertain of giving satisfactory results as cauliflower, particularly if grown for an early crop. It is often rather amusing to see how the failure to obtain a crop astonishes our

full fledged scientific European gardener, on his first attempt here. When he starts in the spring with his plants, all the conditions are apparently the same, as they were when he planted near London or Paris, but as the sea-

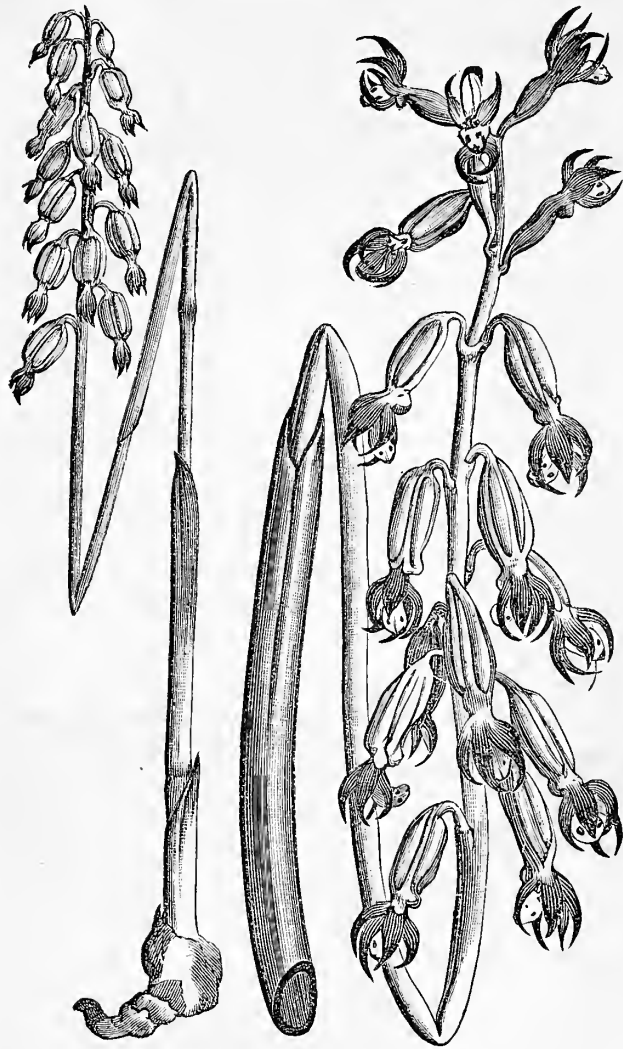

CORAL ROOTS—CORALLORHIZAS.

son, advances the conditions change; and he has a drier atmosphere and a higher temperature, making a climate entirely unsuited to the crop, and the result in five cases out of six is partial or entire failure. But there is one way to obviate this failure. If the ground has been properly prepared by heavy manuring, and if good plants are on hand, they should be planted the first week in April—certainly not later than the second week. By the middle of May they will have made a fine growth, but by this time the high temperature begins, accompanied by a dry atmosphere; to obviate the effects of these, and to produce the crop in perfection, copious watering is essential. One of my neighbors in Jersey City had a patch of about half an acre, which he annually, for many years, planted in cauliflower, and never failed to have a heavy crop, but his land was so situated that he could thoroughly irrigate at pleasure, which insured his success. When a few dozen plants are grown for private use, and where water is convenient, each plant should have, if the weather is dry, at least three gallons each evening for about two weeks before the time of heading up. A mere sprinkling is utterly useless; enough must be given to reach the lowest roots. When the ground is thus saturated, the temperature is also lowered and the atmosphere surrounding the plants made also more humid—conditions indispensable for the well being of the cauliflower crop.

The Coral Roots.

There are some native plants so strikingly odd in their appearance, so unlike the general run of plants, as to attract the attention of those who do not generally take much notice of wild-flowers. Among the singular looking things that those who ramble in the woods are likely to come across, are the Coral Roots; they are generally a puzzle to those who have no knowledge of botany, on account of their lack of green leaves and the peculiar lurid look of the stems and flowers; hence it happens that specimens are frequently sent to us for a name. The coral roots belong to the genus *corallorhiza*, which is from Greek words for coral and roots, both names having reference to the peculiar much-branched roots which bear some resemblance in form to a sprig of coral. These roots are believed to be parasitical upon the roots of other plants, and as they thus steal their nutriment, the Coral Roots have no need of foliage; the only approach to leaves is some small sheaths at the lower part of the stem, which, like the rest of the plant, are brownish or yellowish. They belong to the orchis family, which is noted for the peculiar structure of its flowers, and as it would not be easy to describe the flowers of these plants without enlarged drawings, we content ourselves with an engraving which shows their general aspect. The flower, when carefully examined, is not without beauty, the lip, or large lower petal, which is usually

white, being often handsomely marked with crimson dots. There are four species in the Northern States, two of which are shown in the engraving; the smaller one is *Corallorhiza odontorhiza*, the tooth-rooted, and the other *C. multiflora*, the many-flowered Coral Root; they are found in woods from July to September, the first named being somewhat the earlier. We regret that the specimens came to us without

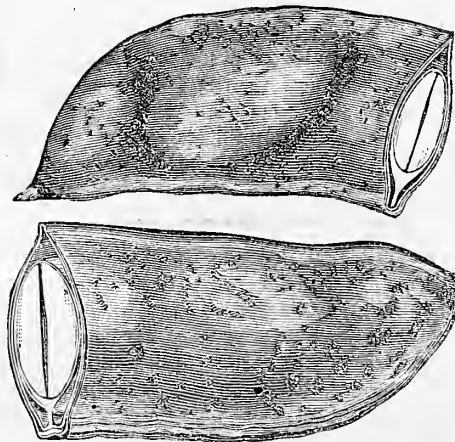

LIMAS—UPPER, OLD; LOWER, DREER'S IMPROVED.

the peculiar roots from which the plants derive their name, and we would request those who send us specimens for name, to always send the root if the plants are small, and in the case

of large plants to examine the root sufficiently to inform us of its character, whether fibrous, tuberous, etc. The herb doctors consider the coral root, at least the smaller of these two, as possessing medicinal properties, and use it as a



LINDLEY'S BUDDLEYA.

stimulent diaphoretic, and it is in their nomenclature called also *Crawley* and *Dragon's-claw*.

Lindley's Buddleya.

Last summer we grew *Buddleya Lindleyana* for the first time. It is a sort of half shrub, growing about three feet high, with leaves and flowers of the shape and size shown in the engraving. It blooms abundantly, bearing flowers at the end of each branch of a fine violet purple color. This species was brought by Fortune from China, and named by him in honor of Dr. Lindley, while the generic name commemorates an English botanist named Buddle. There are some eighty species, most of which are found in South America and other warm countries. This species is quite hardy in the Southern States, but having but one plant we did not care to test its hardiness.

PRESERVING FLOWERS.—WINTER BOUQUETS.—This series of articles is interrupted this month, as the writer has had so much visiting of fairs to do, that he has been unable to make the necessary experiments. In this, as in all similar matters, we like to speak from experience. All flowers to be dyed, and all the grasses to be crystallized, colored, or otherwise treated are first dried, and when a stock of them is secured, they can be made up at leisure.

THE HOUSEHOLD.

(For other Household Items, see "Basket" pages).

A Useful Piece of Furniture.

In many rural households, the space allotted to the kitchen is often cramped and narrowed too much. Women are not often consulted when houses are built, and it is usually the kitchen that suffers for lack of room. A piece of kitchen fur-

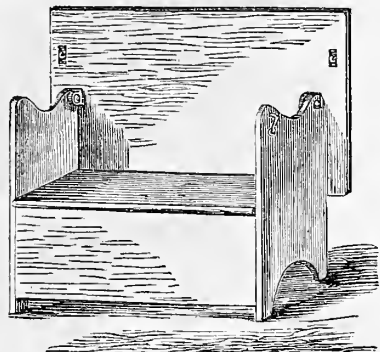

Fig. 1.—AS A SETTEE.

niture, therefore, that will answer three distinct purposes, is a great convenience. Here is one (figure 1) that is at once a settee, a trunk, and an ironing table or bake board. There is a box or trunk, in which one may stow away many things that usually lie about, having no special place allotted for them otherwise. The lid of this trunk

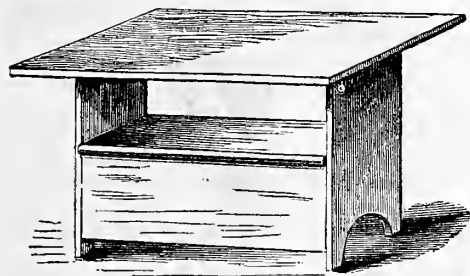

Fig. 2.—AS A TABLE.

forms the seat of the settee. The ends are raised up, forming the arms. The back of it is pivoted upon one side of the ends, and when it is turned down, as seen in figure 2, it forms a table. When it is turned down, it is held in its place by two small hooks, seen in the illustration at figure 1.

Household Carpentry.

The short days and long cool evenings, remind us of the approach of Christmas, and already many are thinking of Christmas presents, and preparing for them. In the majority of cases the most appropriate present is one of little intrinsic value, so far as the materials are concerned, but upon which pleasant labor has been expended, so that the present becomes truly valuable to the recipient, for the reason that it is the handiwork of the giver, who has wrought many kind and loving thoughts into the gift. In the case of Christmas presents, the point of all others to be decided, is, "what shall I give?"—This being determined, all the rest becomes comparatively easy. Among the articles that are frequently purchased for presents, are little parlor or chamber ornaments, such as brackets, match-boxes, clock-racks, and other little tasteful and useful articles made from wood. Those offered for sale are made upon the large scale by machinery, but very beautiful things of this kind can be made by hand, if one has a fair amount of skill and a good share of patience. The materials and the tools cost but little; of course the finer the wood, the handsomer will be the work, but black walnut makes up sufficiently handsome, and can be had almost anywhere; for small articles the wood of cigar boxes answers well, especially if care be taken to select the finer

kinds, and pine and other light colored woods may be stained, if no other material is at hand. The wood should not be over one-fourth of an inch thick, and for small work it may be only half that thickness. A saw is required which has very fine teeth, with an exceedingly narrow blade to allow of ready working in curved lines, and it must be mounted in a manner adapted to the work.

A very neat saw is now sold for this kind of work, and is shown in figure 1. The saw can be readily put in and taken out of the frame, by turning the small thumb-screws at the ends of the arms. The work may be done on a ordinary table, or a bench may be provided, consisting of a smooth board $\frac{1}{4}$ of an inch thick, 12 inches long, and 8 wide, in one end of this a piece is cut out like a letter V, and the board screwed to a table, so that this cut end projects about two inches. Having determined what to make, the next thing is to fix upon the design, which may be made as elaborate as one chooses; sets of designs of various articles made of full size to serve as patterns, are furnished with the saw above figured, but any one with a little ingenuity, can make a design to suit the fancy.

Take the back of the match box, figure 2, as an illustration; this has its two lengthwise halves exactly alike, hence only half the pattern need be drawn. The half pattern being set off on a piece of stiff paper, the paper is then doubled and the pattern cut out, using a sharp pen-knife with a smooth board to cut upon.

Upon unfolding the pattern, both sides will be exactly alike. In drawing, use a ruler for all straight lines, as any inaccuracy will be more readily noticed in this part of the work than in any other. The pattern is then laid upon the wood, and its lines traced with a pencil. All the openwork parts of the design, from which the wood is to be cut out, will need to

be made with a large awl, to admit the saw. The manner of holding the work upon a table is shown in figure 3, a different style of saw is shown there, but the difference is only in

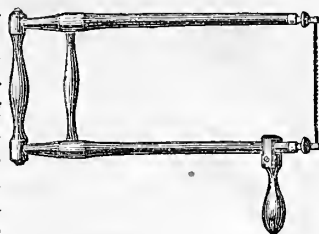

Fig. 1.—THE SAW.

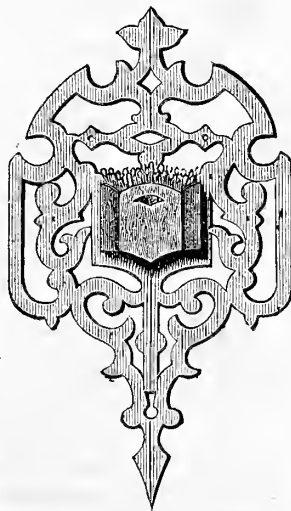

Fig. 2.—MATCH-BOX.

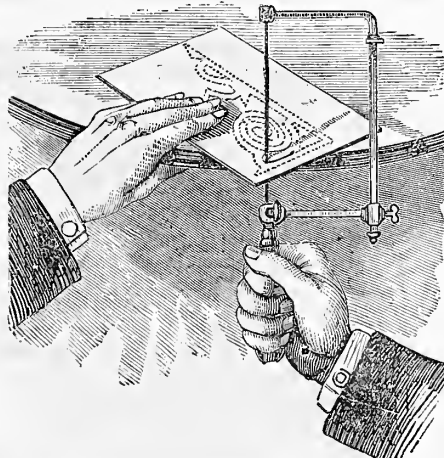

Fig. 3.—MANNER OF HOLDING THE WORK.

have one or more holes made with a large awl, to admit the saw. The manner of holding the work upon a table is shown in figure 3, a different style of saw is shown there, but the difference is only in

the frame. If the little notched bench referred to is used, then the part to be cut should come directly over the V-shaped notch. The saw must be inserted in the frame so that the teeth point towards the handle, as the cutting is done with the downward stroke only. The outside lines of the pattern being cut, then the upper end of the saw is removed, by unscrewing the clamp, and inserted in one of the awl holes, and each portion of the interior portions of the pattern cut away one after another. As with any other mechanical work, a certain amount of practice is required before this can be done readily; it will be found that when the saw is working in the direction of the grain, it is more difficult to guide than when cutting across it; if the saw gets fast, as it sometimes will, do not use force to remove it, as it is very thin and may be broken; care and patience will overcome the difficulties, and the manner of handling the work will come with experience. Rough edges may be smoothed by the use of sand-paper and a file; when a piece has several parts, it is put together with brads, first boring holes with an awl. The best finish for articles of walnut, is to rub them over with linseed oil. We shall have something more to say on this kind of work at another time. By reference to the premium list, it will be seen that the Publishers have included this saw among their premium articles, or it may be obtained from them for \$1.25, post paid.

Home Topics.

BY FAITH ROCHESTER.

CRYING BABIES.

A young mother and a neighbor just called in a moment to ask me, "Did you ever give Soothing Syrup to any of your children?"—"Never"!—"I didn't know but I had better get some for my baby, I can't bear to hear him cry so."—It is certainly very hard for the mother to bear, and it must be hard for the baby, but soothing syrup wouldn't help either of them in the end. The baby is only three weeks old, and during the last week, since the mother dismissed her hired girl, and began to take the care of her little family, the baby has cried a great deal, generally resting pretty well at night, however. The parents have rocked it and walked with it, and the little thing wants to be tended in some way almost constantly. I asked if there seemed to be any danger of a rupture from its crying. Since no danger appears, I could only advise the mother to keep as still and quiet as she can herself, eating plain nourishing food and resting as much as possible, and try time and patience instead of soothing syrup. The *Agriculturist* quoted a statement from the California Medical Gazette, a few years ago, that this popular syrup contains nearly a grain of morphine to an ounce of the syrup, so that the dose for a child three months old, is equal to ten drops of laudanum. In San Francisco, where about 100,000 bottles of soothing syrup were sold annually, it was also the case that one-third of all the babies there died under the age of two years. Soothing syrup indeed!

A neighbor recommends to this young mother some kind of patent pills, which had a wonderfully quieting influence upon his babies years ago; but none of us know what these sugar pills contain. Others would recommend, some one thing, and some another, all with a view of quieting the baby.

The child needs a healthy mother more than anything else, and its mother wrongs it by her well-meant efforts to do more work than her present state of health will warrant. Calves and colts are not so treated, and they have no need of drops and syrups. If baby cries, it is probably uncomfortable in some way, though I suspect it has already learned to want "tending." I can hear my neighbor's little one, and it seldom sounds to me like a cry of positive pain. If my own babies only cried like that, it seems to me that I could bear it more easily when they get into a crying spell. I wonder if it can possibly be because this one is not *my* child, and so does not pull upon *my* heart strings? No, I hardly think that explains the difference, for I

was glad to find that my care of my neighbor's new baby, while its mother was unable to dress it, called out the same tender, motherly, and worshipful feeling toward the innocent new-comer, that I had felt for each of my own babes.

WHAT IS THE MATTER?

I have noticed a great difference in the crying of children. Some babies, and some older children, when they cannot have what they want, or when they feel unwell, keep up such a moderate kind of "boo-hoo-hoo" that no one is much affected thereby. Other babes cry with all of their might, going so nearly frantic if their pain of body or mind is not allayed, that all in the vicinity are nearly driven frantic also. This difference depends much upon temperament, but sometimes it seems to be the result, in considerable measure, of different methods of baby-culture. But, oh dear! how can we know just the right way each time? A baby is such a complex thing! It has in it the blood of so many ancestors, all of which may modify its mental and physical constitution in ways we little dream of—for I have little faith in the rather common latter-day doctrine, that parents are wholly responsible for the peculiar organizations of their children.

"What is the matter with that child, that it cries so?"—"Firstly, is it a sticking pin?"—"No."—"Has it been hurt in any way?"—"No."—"Is it colic?"—"If so, it draws up its legs and inclines to double itself together while crying, and perhaps its feet are cold at the same time. Warmth, by external application of warm cloths over the bowels, or simply a warm hand underneath, as the little one lies face downward, is the simplest and best cure for colic, and a gentle patting upon the back at the same time may help on the cure. *Don't* try the various teas so generally recommended. If you begin on one, you will probably have to follow it up with another. Not a drop of any kind of "herb tea" have any of my babies taken.

But what is the matter with the screaming baby? Ear-ache perhaps, as several times with mine after hot windy weather lately. Get a piece of cotton-wool—pull it out of a bed-quilt or comfortable if you have no other—and wet it with sweet oil or glycerine, and stuff it into each ear of the sufferer to soften the wax, the hardening of which, from undue exposure to cold or wind causes the ache. If the baby is teething, and its gums are troublesome, it may be best to call the doctor, but look carefully to its diet, and keep its nerves as quiet as possible. If you can not find the source of its trouble, and it still cries, wet a clean napkin or soft towel in cool (not cold) water, and lay that gently over its head and forehead, and possibly it will stop crying at once, and drop asleep in a few minutes. I have tried this more than once, with success. After all, perhaps the baby was only hungry, and having asked in vain, by all the pretty ways of asking that it knows, it has cried out in despair or rage, or earnest entreaty, while it has been tossed, and trotted, and chirruped to, and sung to, and dosed, perhaps, all for nothing. You thought it was not time for it to be hungry, but its last meal may have been spoiled in some way, so that it got little, or was obliged to throw it up almost as soon as swallowed. But do not offer it the breast until you are sure that something else is not its trouble. It may be suffering from too much food already.

It is *not* a very simple and easy thing to bring up a modern baby in the midst of modern civilization. Nevertheless, it is the most interesting work and study that I know of at present.

POISON IN GREEN WALL PAPERS.

The *Agriculturist* has already warned its readers of the danger lurking in the bright green of paper-hangings, but the matter should not be lost sight of. Medical authorities state that this is quite a common cause of illness, especially among children. Arsenic is generally used in the green coloring, and so poisonous is it, that many persons, both young and old, have been made positively and dangerously sick by living or sleeping in rooms where the wall-paper was green, or largely of this color. Others have suffered in less degree from this poison, and a decided change for the better,

following a removal from rooms so papered, or a removal of the suspected paper from the walls.

Never give bits of green paper or green cloth to small children who will be likely to suck or chew them, or serious poisoning may be the result. While on this subject, let us speak also of the visiting and other cards with enameled surface, made shining by the use of poison white lead, very dangerous in the hands of young children.

WARM UNDER-CLOTHING.

Whether it shall be made of flannel or not, who shall say? Some strongly advise flannel next the skin for all seasons of the year, others advise it only for winter, and others think flannel too irritating to be worn immediately next the skin of the whole body at any time. Having decided this matter for ourselves, according to our own best light upon the subject, the most important thing is to pursue an even course, not wearing a flannel undershirt one week, and a cotton one the next, with no special reference to the time of year and its probable changes. The skin gets accustomed to either cotton or wool, so different in their texture and feeling, and changes from one to the other require considerable judgment. Careless changes from woolen under-garments to cotton ones may cause diseases of the lungs or of the digestive organs.

It is certainly reasonable that warmer clothing should be worn in winter than in summer, and it will be time, when the *Agriculturist* for November is at hand, for mothers to be putting winter garments on the children. The little boys should all have warm under-drawers of woolen or of cotton-flannel. These may be cut by the long trousers pattern, but without any seam at the sides, and with more fullness around the body, as the two legs need not be sewed together, except a part of the way in front. Such drawers should button to a warm-sleeved under-waist, or be attached to the same when made. They should be gored at the ankle, both on the inside seam and on the fold opposite, so that they may fit well under the stockings. Left open at the bottom a few inches, they lap over more smoothly. Some mothers cut under-garments of their small children like night drawers, or with waist and drawers in one piece. If short trousers are worn, warm under-drawers, reaching to the ankle, should surely form a part of the same costume, and leggins or high-top boots should be added in cold weather. A fundamental principle is, "*keep the extremities warm.*" Many children, perhaps the majority of the little folks, are stunted in their growth by insufficient clothing, especially upon the lower limbs during winter.

Consider the barbarism shown in the winter-clothing of little girls. Imagine yourself walking to school, with the thermometer in the neighborhood of zero, or lower, and nothing covering your flesh between your shoe-tops and the bottom of your dress skirt—a space of several inches perhaps—except one thickness of stocking. Woolen stockings perhaps—you may have thought your duty done when you substituted home-knit woolen stockings for sale ones of cotton. But just think how little protection that really is, and, as I said before, imagine *yourself*, or your husband, dressed in that style in cold weather. Your skirts, at least, afford you some warmth, but look at the little girl's skirts. They seldom protect even her knees from the blast, and when she sits down hurriedly upon a cold bench or chair, there is often but one thickness of cotton between her flesh and the freezing board. It is not uncommon to see little girls, under four years of age, sitting upon the cold floor, with their skirts spreading out in such a way as to leave only their drawers for protection from cold beneath them. Very little dependence should be placed upon skirts except for ornament, while drawers and trousers should be well looked after as actual protection from exposures of all kinds.

It will not answer to leave our little girls without long under-drawers, because they wear leggins, when out of doors. One thickness of stocking on the lower part of the leg is really not enough for in-door wear. Put yourself in the little girl's place, and how would you like it?

Don't tell me that little girls have dressed in that way these many winters, and it hasn't hurt them. All that talk about this and that thing not having done hurt, because one has managed to live in spite of it, does not convince me. Why is it that more than half of the children die under the age of five years? Why have we no healthy women?

The clothing should be evenly distributed over the body. The average school-girl under ten years of age, has perhaps four, possibly five, thicknesses of cloth upon her waist—supposing that she wears a high apron and a low-necked chemise and skirt waist. Probably she has not more than three thicknesses between her elbow and waist, the lined dress sleeve and the apron above. Between her waist and knees we will suppose four or five thicknesses, lower than that, above the shoe, only one thickness. Is it reasonable? Dare you risk it another winter while diseases of all sorts are abroad? They usually make their victims of such persons as have prepared *their bodies to take diseases*, by lowering the vitality in some way. Of course, then, all of us who have given thought to the subject, will straightway provide long warm under-drawers for all of our children. While we are about it, let us put them upon ourselves; for every woman needs them.

Something About Soups.

Our correspondent, "Rel," sent us some time ago an account of Prof. Blot's manner of making soup. The recent death of Prof. Blot gives them especial interest. He was earnestly engaged in the attempt to teach our people better and more economical use of food, than is generally practiced, and his loss is greatly to be regretted.

POT-AU-REU.—"Six pounds of fresh beef (ribs, knuckles, or loin) in a crockery kettle, with five quarts of cold water, salt, and a little pepper, on a slow fire. Take off the scum carefully when it rises. Add two white onions with one clove in each, a small parsnip, a carrot, two middling-sized turnips, half a head of celery, two leeks, two sprigs of parsley, one of thyme, a clove of garlic, a bay leaf, and a little caramel to color it. Simmer five or six hours. Dish the meat with the parsnips, turnips, and leeks around it, to be served warm after the soup or kept for the next day. Strain the broth, skim off the fat at the top, put back on a good fire, and at the first boiling pour on croûtons in the soup-dish and serve."

Thus endeth the Professor's recipe. Observe, firstly, that you must use a "crockery kettle"—that is some good soup-kettle. Many are the husbands who expect as good home-made soups as they get at first-class restaurants, and many are the discouraged wives who would gladly cook to please their husbands, but who neither of them dream that anything better than a common iron kettle is necessary in which to make nice soup. So, nine times in ten, the soup is more or less flavored with iron. Prof. Blot always says "a crockery kettle" or "a stew-pan" when he mentions the utensil for cooking any dish, meaning the glazed or enameled ware. Marian Harland tells us never to cook onions in an iron kettle.

Observe, secondly, that you are to "simmer" your soup "for five or six hours." To simmer is to boil gently, yet the boiling should not cease for a moment during those five or six hours.

Observe, thirdly, that you must skim off all of the fat. Many people imagine that the melted tallow gives richness to the soup, but all the best cooks agree in saying "take off all of the fat"—and so, I think, says every educated stomach.

CROÛTONS.—Cut slices of the soft part of bread, either round, square, oblong, or star-shaped, and about a quarter of an inch in thickness. Have hot butter in a frying-pan, on a sharp fire, place the slices of bread in it, turn over when fricid on one side, and take off when both sides are of a fine color; drain them as dry as possible, and they are ready for use. These are excellent in pea and bean soup, but as some may object to them, it is best to serve in a separate dish, to add to the soup in the plate.

BOYS & GIRLS' COLUMNS.

Horse Trees.

We must tell you about a horse-tree. No, not a horse-chestnut tree, but a tree, or rather trees, in shape like a horse!

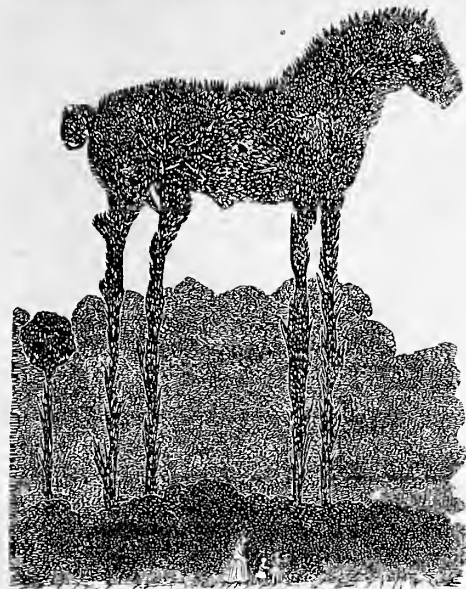

ENGLISH HORSE TREE.

the Gardeners' Chronicle, of London. Perhaps you will remember some pictures you have seen, of old gardens of a hundred or more years ago, when it was fashionable to clip trees and shrubs into the shape of animals...

A Personification.—Hornets' Hop.

Some artists have a great fancy for personifying birds, quadrupeds, insects, and even inanimate things. By personifying, we mean giving the animals or things human expressions, and drawing them as if they were performing human actions.



HORNETS' HOP.

them, were beasts, birds, or insects, with the most comical countenances, engaged in doing the most ridiculous things. For instance, there would be a grasshopper mowing with a scythe, a frog with a barber's apron...

—Of course you never did, and so we publish the picture that you may see for yourselves how they do it. Hornets make people dance sometimes, as many a boy knows, and we do not see why they should not do a little dancing themselves. It is a funny idea of the artist to make these usually troublesome insects having a hop all by themselves.



THE BEETLE.

the hornets, they attacked the horse, and you may be sure that there was a very lively time for a few minutes. They have the credit of being very industrious insects, and of working all night when the moon shines.

Aunt Sue's Chats.

ALONZO D. G., thinks it "makes an evening pass pleasantly, to do tricks and experiments," and wants to know if I don't "know some." Yes, Alonzo, I "know" lots of them, and have kept a dozen people busy for an entire evening.

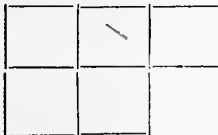

Then say to the company, "there you see five perfect squares, take away three matches only, and leave three perfect squares." And now is a good time to study characters, some will see it at a glance, others look a little while, don't see it, and lose interest in it;



having three perfect squares. I could tell you of several more, but must attend to some other of my correspondents now. You might cut that paper four inches square, (?) that was mentioned in the Agriculturist some months ago, and tell your friends to cut it in such a manner that they can walk through it.

Aunt Sue's Puzzle-Box.

NUMERICAL ENIGMAS.

- 1. I am composed of 12 letters: My 7, 1, 11, 4, is a girl's name. My 10, 2, 5, 6, 12, is capacious. My 3, 9, 8, 7, is a number. My whole is where the author of the enigma lives. HERBERT J. K.

- 2. I am composed of 17 letters: My 1, 6, 11, 4, is a pronoun. My 5, 15, 7, 17, is that which confirms. My 9, 16, 10, is a color. My 13, 2, 3, 12, is much used by sportsmen, My 8, 11, 14, is a Scripture name. My whole is a command, A SUBSCRIBER.

PUZZLES.

- 1. I am a musical instrument, and although I contain two large vessels, and three-fourths of another, am often put into my first. QUIZ. 2. Take a certain tree; break the last half of it, and it may benefit you, but if you reverse the first half, and break that, you will surely come to grief. F. R. S. 3. With five letters express a sentence containing nineteen letters.

DIAMOND PUZZLE.

- The center letters, perpendicular and horizontal, name an Indian princess. 1. An insect. 2. A place of rest. 3. A title. 4. A cake. 5. A labial. ELLEN M.

CROSS-WORD ENIGMA.

My first is in daughter but not in girl, My next is in crimping but not in curl, My third is in peach but not in pear, My fourth is in table but not in chair, My fifth is in feather but not in bird, My sixth is in letter but not in word, My seventh is in Annie but not in Nell, My eighth is in tumbled but not in fell, My whole has now left us: we loved him well. L. F. M. L.

EQUIVOCAL WORDS.

- 1. To instruct—to send to jail—to perform. 2. A sort of dictionary—an agreement. 3. An edible—a disease—to salt. 4. Part of an indictment—a title—to reckon. 5. A fish—a fruit—a mechanical contrivance. 6. A small sail-boat—a trade—cunning. BESSIE.

SQUARE WORDS.

- 1.—1. Stingy. 2. A girl's name. 3. An acid. 4. A title. P. INK AND CAP I. TAL. 2.—1. Fashion. 2. A precious stone. 3. Black. 4. Animals. "A YOUNG MAN."

TRANSPOSITIONS.

- (Fill the blanks with the same words transposed.) 1. The — ate up the —. 2. He went to — to — his wrongs. 3. The — which she wore, came from —. 4. Ask the — to — the volume. 5. The bush has — — always.

ARITHMETICAL PUZZLE.

- 1000 and tea. 100 and an a. 150 and go. 1 and h. 1001 and nan. 100 and ein. 55 and see.

My initials are things of great use to us, My finals go faster than the fastest "bus." NIP.

A targe singue lilw claydind wedgeonlack shi stefdec.

ANSWERS TO PUZZLES IN THE SEPTEMBER NUMBER.

CHARADE.—Armada. SQUARE WORD.— GRANT ROME O AMASA NESTS TOAST

Cross-Word.—Powder. DIAMOND PUZZLE.—Constasy. C COT FENCE PENSIVE CONSTANCY BREAKER BENCH ACE Y

Pr.—If you would be pungent, be brief; words are like sunbeams, the more they are condensed, the deeper they burn.

GEOGRAPHICAL ANAGRAMS.—1. Montgomery. 2. Mil- ledgeville. 3. Mobile. 4. West Point. 5. Manchester. 6. Liverpool. 7. Albemarle. 8. Honduras.

CONCEALED SQUARE-WORD.—S T A R
T O R E
A R M S
R E S T

NUMERICAL ENIGMA.—Salisbury Mills, Orange County.

Thanks for letters, puzzles, etc., to J. & C., Isaiah S. R., Robert F. Q., Robt. W. Moore, Ambrose M. S., and H. R. G.

Send communications for the Puzzle Box to Aunt Sue, Box 111, P. O., Brooklyn, N. Y., and not to 245 Broadway.

Marmots—Tame and Wild.

Did you ever see a Marmot? Very likely you will all say no, although you have seen one, but under a different name. At all events, you have read about the European marmot, which is found on the Alps, and other high mountains. It is about as large as a hare, with yellowish



MANNER OF CATCHING A WOODCHUCK.

gray fur, and lives in holes among the rocks, frolicking about all through the short summer, and sleeping through the long Alpine winter. Just think of going to bed when the snows first come, and sleeping on and on, until they have melted away before the spring sun. The picture below tells a part of the marmot's history. These people are interested in feeding a marmot, and they are dressed quite differently from our people. They are Swiss, and the picture tells us that the Swiss catch and tame the marmot. They are very fond of these animals as pets, as they are quite gentle and playful, and make pleasing companions. Sometimes the Swiss boys, who go to other parts of Europe to earn money as organ grinders, take a tame marmot with them, as the animal is a curiosity to those who do not live in the mountains. The American marmot can also be tamed.—“You didn't know that there were any marmots in this country.”—There are, and plenty of them, only we call them by different names, which, though more familiar, are not so pleasing as marmot. We know our animal as the woodchuck or groundhog. There is no reason why it should not be called a marmot, for it is own brother to the Alpine one; by own brother we mean that it has the same kind of feet, teeth, etc., and in all the important things by which naturalists classify animals, the two are closely alike; ours differs from the European in color, among other things, and has considerable black about it. Those of you who live upon farms, no doubt know this marmot very well under the name of woodchuck. How the fellows like to frolic in a field of clover on a bright moonlight night, and what havoc they make in the clover! They do not dislike a bit of tender cabbage from the garden, and take it altogether, we do not think the farmer would look any more favorably upon the animal if it were called marmot, than he now does. Did you ever see a tame woodchuck? We have, and a funny little chunk of a fellow it was; it had been petted so much, and fed so freely, that it waddled about in the most laughable manner. They do not forget their sleepy ways, even when tamed; when winter approaches, they roll themselves up into a ball, putting the head down against the belly, and away they go for a long sleep; they are of no trouble during the winter, as they have only to be stored away in a box with plenty of hay and cotton, and they



FEEDING THE TAME MARMOT.

will tuck themselves up in bed for a long nap. We must tell you how a young friend of ours, who is a great hand for catching animals, captured his woodchuck. The animal was in its hole, and as our friend had nothing on hand to dig with, he resorted to a clever trick. Having a piece of fish-line in his pocket, he made a slip-noose in one end of it, and tied the other end of the line to a stout stick; the noose was then opened, and passed into the hole; the woodchuck did not like this, but snapped at the string, at which the boy gave a jerk, and caught the animal by its very long front-teeth, then he had only to pull, and the captive was hauled out of its hole, much against its will. Our friend sent us a drawing of the affair, which we give here; it is not as cruel as it looks, and if one is to capture a woodchuck, no doubt this is as gentle a way as any, and the inconvenience at the time may be made up for by after-kindness to the captive. It has one advantage over other pets, as it can be kept asleep all winter.

Popping Corn.

Isn't it fun to pop corn?—and when it is popped isn't it good? Most boys in the country grow a few hills of pop-corn to furnish them amusement in the winter evenings. There is some skill to be used in so simple a thing as popping corn. In the first place, the corn should be well dried, for when too fresh and soft it does not pop well at all. Then a wire popper with a long handle is the best thing to pop it in. A very small handful of corn, only about enough to cover the bottom, is put in the popper and the cover fastened down. Then we must heat the corn gradually, holding it at a distance from the coals, and when it is well heated through bring it nearer to the fire, when the popping will begin. You must

shake all the time, and the more the corn pops the faster you must shake to prevent burning. If the corn is of a good kind a very little will fill the popper when finished. Pop! pop!—how the little grains bounce about as they jump up and put on their snowy night-caps. Look at a popped grain. It does not seem at all like a kernel of corn; it is fairly turned inside out. What makes the corn pop and behave in this way? The chemist says that the corn contains an oil, and that the heat turns this

oil into gas, and when the pressure of this gas gets strong enough to burst the grain, pop it goes. That corn contains oil, may be new to you, but there is oil in

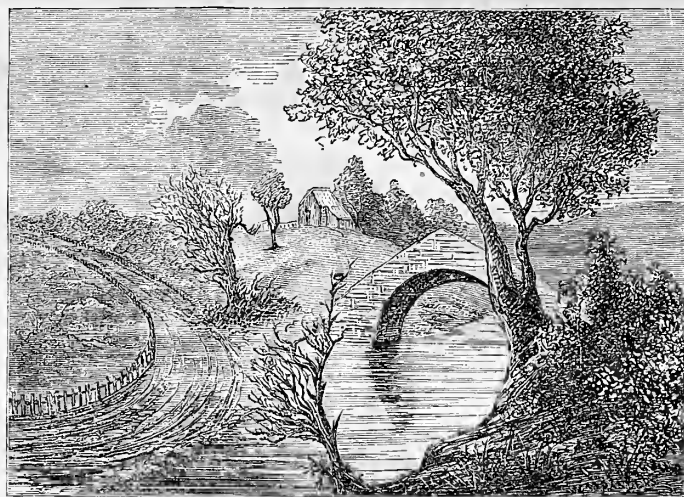

No. 440.—A PUZZLE PICTURE.—LOOK SHARP!

it, and in some kinds of corn a great deal. Sixteen gallons of oil have been obtained from one hundred bushels of grain, and very nice oil too. It has but one fault, and that is it costs too much to get it out of the corn; while the mineral oil lasts—the petroleum from which they get kerosene—it is not likely that we shall feed our lamps with corn oil. When you hear the grains go off with a “pop,” and a “sput,” just remember it is the oil that affords you all the fun, and turns the hard and flinty grains into beautiful masses of corn-starch, not only pleasing to look at, but wholesome to eat.

About Secrets.

BY M. H. G.

Little Margy whispered in her Aunt Margy's ear: “Promise not to tell anybody, and I'll tell you a secret.”

“I'm afraid I can't promise,” said Aunt Margy. “It is not easy to keep a secret.”

“Why! I think it is,” said little Margy, “I have kept my secret two whole days.”

Aunt Margy laughed. “I am afraid your secret, like the secret of King Midas, will be whispered about sooner or later,” she said.

“What was his secret?” asked little Margy.

“Why, he had asses' ears, which he was careful to hide under his long-eared cap,” said Aunt Margy, “but the barber who shaved him, saw his long ears—”

“And then he ran and told all the folks,” interrupted little Margy.

“No,” went on Aunt Margy, “he didn't dare to tell anybody, for fear that his own ears might be cut off, but yet he could not keep the secret all to himself. So he dug a hole in the ground, and whispered down to the earth: ‘King Midas has asses' ears.’ Then he filled up the hole, but a reed sprung up on the spot, and whenever the wind blew, the reed whispered: ‘King Midas has asses' ears.’”

“What a funny story!” cried little Margy. “But it isn't true, is it?”

“No,” answered Aunt Margy, “but the old Grecian historian tells it. It teaches us how hard it is to keep secrets. But the best way is not to have any.”

“I think so too,” said little Margy, “so I tell you mine. I am going to make papa a present on his birthday. I have made him a butterfly pen-wiper, with red glass-eyes. Don't tell I told you, until I give it to papa to-morrow—please don't, I mean.”

“I won't tell,” said Aunt Margy. “I can keep a secret one day. I enjoy hearing such secrets as this.”

“But poor King Midas!” said little Margy, “to have to wear a cap, instead of a crown, to hide his asses' ears.”

“And the barber should not have whispered the secret even to the earth,” said Aunt Margy, “for it is not honorable to tell the secrets of others, especially if telling will make them unhappy.”

A Puzzle Picture.—The puzzle picture given above is, we think, one of the best we have ever published. In most of them, after the concealed portion is known, it is impossible to see anything else, but in this, the landscape remains just as perfect after the trick is found out as before, and in looking at it one can hardly see a trace of the other, if he tries ever so hard. Some of the puzzle pictures that we have published, have been copied in other countries, and we should not be surprised to meet this one in some European journal.

The Ethics of Life Insurance.

Fire and marine insurance are purely matters of finance; the rendition of an equivalent for losses incurred. No great moral principle, beyond the general morality of trade, is involved in their details. Important as they are, they cannot be said to be based upon any moral principle, or to tend to the elevation of the standard of morality. Their operation is founded only upon economy, and their details are matters of dollars and cents.

It is not so with life insurance. Here a great moral principle is involved. The transaction is not merely one relating to dollars and cents. Morality and religion have to do directly with it. Humanity is elevated, the world made better, and the individual disciplined by self-sacrifice. Considered in view of all this, life insurance rightfully takes its place among the noblest charities man has conceived in aid of his fellow-man.

Life insurance is a moral duty. Rich men are the exceptions. The great mass of mankind never rise above the possession of an ordinary income, and the greatest number live only from day to day. Life insurance is now so cheap that it lies within the possibilities even of the poor. Any man may take out a policy of life insurance and still supply his family with the comforts of life. But moral duty does not end here. He has been the shield of his family during life. It is his duty to see that after his death they are still provided for. After he has passed away, he must still be their shield, and they must still feel his unseen but fostering care guarding them from want and its attendant train of evils. By a judicious investment in life insurance he can effect this, and die, comforted by the thought that his wife and offspring will not be dependents upon the bounty of relatives, or worse than that, upon the cold charities of the world; either of which, to the refined and sensitive nature of woman, is almost as terrible as death. When we consider how few men in the fluctuations of life, are enabled to amass a competence, and preserve it so that it will be available for the future use of their families, the duty of life insurance is made plain. No man that is not utterly selfish can endure, for a moment, the suspicions that his family may be exposed to destitution; no man who is not a confirmed miser, will hesitate to remove every contingency of future want.

In getting life insurance, get the best; and this is to be had in every form, of the United States Life Insurance Co., of this city.

Safe Illuminating Oils.

So much has been written within the past four years, in reference to the dangerous character of the burning oils in common use, so many lives have been lost, and so much property destroyed by means of them, that it would appear almost superfluous to again warn the public of the danger of using anything but the best and highest test oils.

Thousands of families, however, continue to burn oils that are less safe than gunpowder.

The leading refiners have of late given their attention to manufacturing a safer and more reliable grade of oil for ordinary use, and as a result, the more volatile article is being in a measure displaced. Messrs. Chas. Pratt & Co., 108 Fulton st., New York, have been the pioneers in this good work, and as such are entitled to the thanks of the community. Their Astral Oil has now obtained a world-wide celebrity as the safest and best oil of the kind ever made—and it is to be hoped will in time entirely supersede the use of the common article.



And Not Wear Out.

For sale by Watchmakers. By mail, 50 cents. Circulars free. J. S. BIRCH, 37 Maiden Lane, New York.

MONEY MADE RAPIDLY with Stencil and Key Check Outfits, Catalogues and full particulars free. S. M. Spencer, 117 Hanover St., Boston, Mass

**Read This Once—Once!
Then Read it Again—Again!
WALTHAM WATCHES.**

A CORRECT Timekeeper is indispensable to every one who has appointments to keep, **MEN AT WORK**, trains to meet, meetings to attend, in fact any business that is worth doing should be **DONE WELL AND ON TIME.**

For this purpose every one should own a Waltham Watch, and to meet **THE MEANS OF ALL CLASSES**, they are made of various grades, so that every taste and purse can be suited. A **SUBSTANTIAL ACCURATE WATCH** in a Solid Silver Case can be bought for \$17, and an **EXCELLENT SMALL SIZE GOLD WATCH**, for Ladies, for \$30. From these prices they increase in value according to the finish of the movement and **WEIGHT AND PATTERN OF CASES.** Special qualities are made for Railroad use and Travellers. The **STEM-WINDING ATTACHMENT** is now to be had with watches of any size or grade, and in cases of any weight or pattern. To buy one try the following plan first: **WRITE A SHORT LETTER** (on a postal card will answer) as follows:

Howard & Co., 222 Fifth Avenue, New York:
Send me your new Price List of Waltham Watches as advertised in the Agriculturist.
(Sign name and address in full.)

By return mail you will receive the Price List free and post-paid. It is a book of 16 pages, and in it are described **ONE HUNDRED AND SIXTY-FOUR VARIETIES** of Waltham Watches, from which you cannot fail to make a selection. Send us the order according to the directions in the Price List, and **WE WILL SEND THE WATCH** by express, with the bill to collect on delivery. On every bill are instructions to the Express Agent to allow the purchaser to **OPEN THE PACKAGE AND EXAMINE** the watch before paying. If it is not in every way satisfactory you need not take it, but let it **COME BACK AT OUR EXPENSE**; even after you have taken and paid for it, if it does not prove satisfactory you can exchange it, or we will **REFUND THE MONEY** at any time within a year.

Do not let distance from New York deter you from writing, as the farther you are **THE MORE ADVANTAGE IT IS FOR YOU** to buy of us.

We have sold some Sixteen Thousand Waltham Watches on this plan during the last six years, and fully one-half went **WEST OF THE MISSISSIPPI** and to the Pacific States and Territories. At all events if you feel the least interest in the matter, write for the Price List, **IT WILL ONLY COST YOU ONE CENT** for a postal card.

Be sure and mention that advertisement was seen in the *Agriculturist*.
Address:

HOWARD & CO.,

222 FIFTH AVENUE, NEW YORK.

Every Watch warranted by special certificate.

Parents, reduce your SHOE Bills two-thirds, by buying **SILVER-TIPPED SHOES.**



Rifles, Shot Guns, Revolvers, Pistols, Ammunition, Fishing Tackle, etc. For Price-List, see page 157, April No. *Am. Agriculturist*, or address, with stamp,

GREAT WESTERN GUN WORKS,

285 Liberty St., Pittsburgh, Pa.



PITTSBURGH, PENN.

The most complete institution in the United States for the thorough practical education of young and middle-aged men, with the largest patronage, and the best course of study of any business college in existence. Students admitted at any time. For circulars, address

J. C. SMITH, A. M., Principal.

H. W. JOHNS' PATENT ASBESTOS ROOFING PAINT.

Old Shingle, Tin, Slate, Felt, and other Roofs can be made water-tight, and rendered serviceable for many years at a trifling cost with **H. W. JOHNS' PATENT ASBESTOS ROOFING PAINT AND CEMENT** (standard brown and other colors) which are prepared ready for use, and can be easily applied by any one.

SEND FOR DESCRIPTIVE PAMPHLETS, INSTRUCTIONS FOR USE, PRICE LISTS, ETC.

H. W. JOHNS, 87 Maiden Lane, New York,

Patentee and Sole Manufacturer of ASBESTOS ROOFING; BOLLER FELTING, etc. Established 1853.

S. B. Parsons & Sons offer at Flushing, N. Y., Camellias, Azaleas, Roses, and Rhododendrons, and other Trees and Plants.

GOOD CROPS Depend on good Seed, good Soil, good culture. So **Good Health** depends on **Right Living**, and the proper observance of the **Laws of Life**, as taught in the **Science of Health**. \$2 a year; or "On trial" 3 months for 25 cts. Single numbers, 20 cts. Agents wanted. Great Premium Offers. Sewing Machines at Wholesale. **Phrenological Journal**, 3 months, "on trial," for 50 cts. A year, \$3. S. R. WELLS, 389 Broadway, New York.

GEO. A. PRINCE & CO. ORGANS & MELODEONS.

The Oldest, Largest and Most Perfect Manufactory in the United States.

54,000

Now in use.

No other Musical Instrument ever obtained the same popularity.

Send for Price-Lists.

Address

BUFFALO, N. Y.

(CIRCULAR.)

Consumers' Importing Tea Co.,
No. 8 Church Street,
P. O. Box 5,509. New York City.

This is a combination of capitalists to supply the consumers of Teas throughout the United States on the mutual principle.

We have experienced agents in all the best districts of China and Japan to select Teas especially for our trade.

We expect every consumer of Teas to render us all the assistance they can in carrying out our enterprise, as we make a specialty of **SUPPLYING CONSUMERS ONLY** (and allow no middlemen to make any profit on our importations), which will enable us to supply them with Teas at prices lower than have ever been known, and of those fine qualities that seldom reach the interior, being sold only in the large cities and among the very wealthy.

Hoping the consumer will take an interest in our enterprise, and send at once for a circular with full explanations of how to proceed to obtain our goods, we remain,
Most respectfully yours,

Consumers' Importing Tea Co.,
No. 8 Church Street,
P. O. Box 5,509. New York City.

Entered, according to Act of Congress, in January, 1874, by the Consumers' Importing Tea Co., in the Office of the Librarian of Congress, Washington, D. C.

"A TRIAL TRIP." The Science of Health, a First Class Health Magazine, at \$2 a year, will be sent 3 months "on trial" for 25 cts. Single numbers, 20 cts. Agents wanted. Great Premium Offers. Sewing Machines at wholesale for subscriptions. **The Illustrated Phrenological Journal**, \$3 a year, or single No. 31 cts. sent 3 months "on trial," at 50 cts. Try it. S. R. WELLS, 389 Broadway, New York.

"The Verdict."

GOOD CABLE SCREW WIRE

Boots and Shoes

BETTER THAN PEGGED or SEWED.

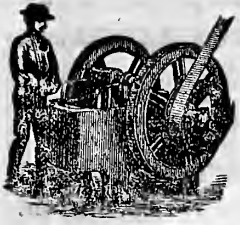

BLAKE'S PATENT STONE AND ORE BREAKER.
 New Patterns, with Important Improvements and Abundant Strength.
 For reducing to fragments all kinds of hard and brittle substances, such as STONE for making the most perfect McADAM ROADS, and for making the best CONCRETE. It breaks stone at trifling cost for BALLASTING RAILROADS. It is extensively in use in MINING operations, for crushing
IRON, COPPER, ZINC, SILVER, GOLD, and other ORES.
 Also for crushing Quartz, Flint, Emery, Corundum, Feldspar, Coal, Barytes, Manganese, Phosphate Rock, Plaster, Soapstone, etc.
BLAKE CRUSHER CO., NEW HAVEN, CONN.

THE MITCHELL WAGON.

THE
 Best Proportioned,
 Best Ironed,
 AND
 Lightest Running
 Wagon in the Market.
 The original, well known
RACINE WAGON.

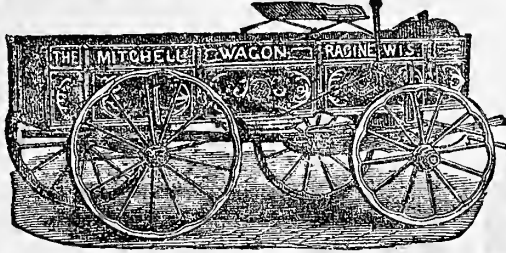

In use and for sale in nearly every
STATE & TERRITORY IN THE UNION.
 All work fully warranted.
 SEND FOR PRICE LIST.
Mitchell, Lewis & Co.,
RACINE, WIS.

SESSIONS & KNOX'S Patent Hard Steel Plows.

Awarded Highest Prizes by the New York State, N. H. State, Vermont State, and New England Agr'l Societies.

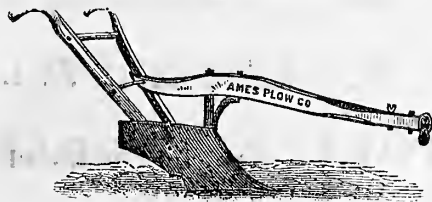

Steel Plows possess many advantages over Cast-Iron Plows. The Patent Hard Steel Plows have all the desirable qualities of hardness, flexibility, lightness, strength, and durability combined, and embrace all sizes and styles adapted to every kind of soil, and to all localities. Perform better work, and pass through the soil more easily than other Plows.

Also Swivel Plows for Side-Hill and Level Land, Eagle, Knox's Pat. Imp'd, and other Plows.
 Made only by
AMES PLOW COMPANY,
 53 Beekman St., New York,
 and Quincy Hall, Boston, Mass.
 Descriptive circulars and price-lists sent free on application.

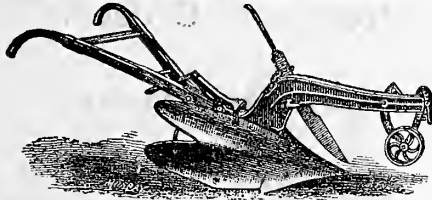

AVOID DEAD FURROWS.

For either Side-Hill or Level-Land work this plow has no equal, having, during its four years' existence, always won the first premiums in competition with the best **FLAT LAND**, as well as with other Swivel Plows. See June number, page 212, of *Agriculturist* for editorial comments, and for particulars address
CARR & HOBSON, 56 Beekman St., New York,

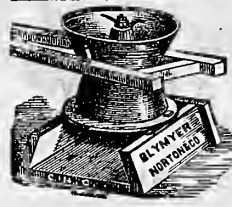

"Every Farmer and Stock-Feeder should have one."
LITTLE GIANT CORN & COB MILL.
HEDGES' New Improved Mill,
 For Horse or Steam Power.

CROSS-CUT AND CIRCULAR WOOD-SAWING MACHINES.
 Descriptive Circulars and Price-lists sent free.
BLYMNER MANUFACTURING CO.,
 661 to 694 West Eighth St., Cincinnati, O.,
 Manufacturers of Cane Machinery, Steam-Engines, Shaker Thresher, Farm, School, and Church Bells, etc.



Nonpareil Farm, Feed, Bone, Drug, and Hand-grinding **MILLS.** Ten sizes. Also the French Cone Burr Mills. Cotton-Seed Hullers. Illustrated pamphlet free. Address
SEDGEBEER, SHEPARD & MILLER,
 181 East Front St., Cincinnati, O.

MORRIS, TASKER & CO.

PASCAL IRON WORKS, Philadelphia.
TASKER IRON WORKS, New Castle, Delaware.
 Offices & Warehouses, Philadelphia, New York, and Boston. Manufacturers of Wrought Iron Tubes, plain, galvanized and rubber coated. Boiler Tubes. Oil Well Tubing and Casing. Gas and Steam Fittings, Valves and Cocks. Gas and Steam Fitters' Tools. Cast Iron Pipe. Lamp Posts and Lanterns. Improved Coal Gas Apparatus, &c.

We would call special attention to our Patent Vulcanized Rubber-coated Tube.

HARNESS, BLANKETS,



HORSE CLOTHING, and HORSE FURNISHING GOODS of every description. Style and grade at prices that please everybody.
ELEGANT NEW STYLES FOR THIS FALL AND WINTER.
C. M. MOSEMAN & BRO.,
 Manufacturers, 114 Chambers St., N. Y.
 Send for Illustrated Price-List.

PHILIP'S SPIRAL CORN HUSKING MACHINE

does its work thoroughly—stripping every ear and nubbing, large or small, completely of husks and silk. Any ordinary two-horse power is sufficient to operate the machine, which is capable of husking 60 bushels per hour. No Farmer can afford to do without it. For Circulars or further information, Address **PETER PHILIP, President, Stockport, N. Y.,** or the Company, Hudson, N. Y.

R. H. ALLEN & CO., of New York, are sole agents for Philip's Spiral Corn Husker in the city of New York, and sell it at the Company's price.

EUREKA SELLS AT SIGHT.
 Does Two Men's Work.
 No sore or cold fingers.—Best Cast-steel.—Last a Lifetime.—Taken 6 Premiums.—Every Farmer wants them.—Will send 2 Samples, post-paid, for 60 cents—or 4 Styles for \$1.00. Agents wanted.
PLUMB & CO.,
 108 South 8th St., Philadelphia, Pa

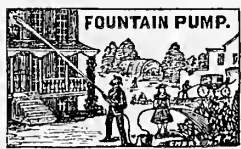

FOUNTAIN PUMP. GARDEN ENGINE AND FIRE EXTINGUISHER.—For Washing Windows, Carriages, etc. Protects Buildings from Fire, and Trees, Vines, etc., from Insects. Throws water 50 ft. Easily carried. No Dwelling, Country Home, or Factory should be without the Fountain Pump. Send for large Illustrated Circular. **J. A. WHITMAN, Sole Proprietor and Manufacturer, Providence, R. I.**

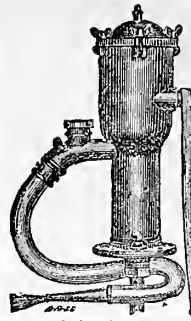

THE PEOPLE'S Force Pumps.

Awarded medal of American Institute over all competitors last fall. For the house and out of doors. Non-freezing, and adaptable to wells from 6 to 100 feet deep. Highly recommended for city houses on account of their great power. Parties about to supply themselves are invited to call and examine. Circulars sent on application. Plumbers are particularly requested to call. See *Ogden Farm Papers*, Dec., 1871. See "Notes from the Pines," on page 181, May number, of *American Agriculturist*, 1874.

Certain parties, with the intent to profit by the well earned reputation of these pumps, the result of faithful manufacture, having imitated them, the Public are cautioned to look for the name, "People's Pump," Patented Aug. 31, 1869, east on the lid, to insure obtaining the genuine article, and to avoid litigation.
W. S. BLUNT, 77 Beekman Street, New York.

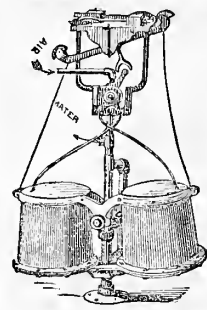

AUTOMATIC PUMPS.

Water driven to any height and distance by compressed air. Country houses supplied cheaply and certainly for bath-rooms, water closets, hot and cold water faucets, etc.
 Plenty of fresh water for stock on farms. Address
HARTFORD PUMP CO.,
 Hartford, Conn.
MASON C. WELD,
 189 & 191 Water St., New York.
AMERICAN MACHINE CO.,
 430 Walnut St., Phila.

HIGGANUM MANUFACTURING CO., HIGGANUM, CT.,

MANUFACTURERS OF AGRICULTURAL IMPLEMENTS OF ALL KINDS AND DESCRIPTION.

Send for a Catalogue, with a description of **THE SILVER EAGLE PLOW**, the best plow built! Our new Farmer's Almanac will be published in November. Will be mailed to any address upon receipt of stamp.

OVER 5000 IN USE OF
INGERSOLL'S COTTON AND WOOL PRESSES,
 INGERSOLL'S HAY AND STRAW PRESSES,
 INGERSOLL'S RAG AND PAPER PRESSES,
 INGERSOLL'S HIDE AND HAIR PRESSES,
 BOTH HAND AND HOUSE-POWER PRESSES,
 for baling all kinds of material, on hand and made to order. For price-list and full information, call on or address the manufacturers,
INGERSOLL & BALSTON,
 Greenpoint, (Brooklyn), N. Y.

LAMB'S KNITTING MACHINE

IS the only Machine that can knit all sizes of work, and narrow and widen it; that can shape and complete, without hand finishing, seamless Hosiery, Gloves, and Mittens, or knit them in all sizes; or knit Ribbed, Double, and Fancy stitches for Underwear, Jackets, Shawls, Scarfs, etc. It knits over 25 different Garments. Over 100 per cent Profit in Manufacturing Knit Goods. The Farmer trebles the value of his Wool by converting it into Knit Goods. Women make \$5.00 a day with it. Agents wanted. Send stamp for Samples of work, and reduced Price-List. Address, **LAMB KNITTING MACHINE CO.,** at Chicopee Falls, Mass.; Cincinnati, O., or Chicago, Ill.

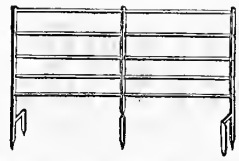

Wrought Iron Fencing of the Best English Make. Can be set up with ease—is an absolute protection against cattle and is ornamental, and practically indestructible. Is superior to every other form of enclosure. Send for illustrated circular.
YARNALL & TRIMBLE,
 147 S. Front St., Philadelphia.

FENCE—PERMANENT and PORTABLE—best ever devised. Send stamps for circulars.
T. H. SPEAKMAN,
 26 North 7th St., Philadelphia.

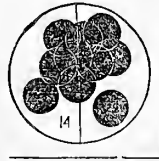

MAYNARD'S BREECH-LOADING Combination Rifles and Shot-Guns.
CENTRAL FIRE
 Reloading-Capped Cartridges. Send for Price-list with Target Illustrations.
Mass. Arms Co., Chicopee Falls.

Patent Double Acting Balanced Valve Water Ram. Superior to all others, or no sale. Address
C. HODGKINS, Marlboro, N. H.

POTASH MANURES.
 German Sulphate of Potash, American do., full strength; Muriate of Potash, Climax Superphosphate, and Dry Powdered Blood, for sale by
GEO. E. WHITE, 100 Front St., New York.

ARTHUR'S

ILLUSTRATED HOME MAGAZINE.

Bright, Cheerful, Progressive, always up to the advancing thought of the times, the HOME MAGAZINE takes rank with the leading and most influential periodicals of the day.

1875

It is on the side of Temperance and true Christian morality. Whatever is hurtful to Society it condemns without fear or favor, and makes itself felt in the Homes of the People as a power for good.

THE GREAT HOUSEHOLD Magazine of America, is more thoroughly identified with the People in their Home and Social Life than any other periodical in the country.

"DEBORAH NORMAN: HER WORK AND HER REWARD." A new serial story By T. S. ARTHUR will be commenced in January.

"FIFTY YEARS AGO; OR, THE CABINS OF THE WEST." By ROSSELLA RICE. These papers will be fresh and new, and of unusual interest.

"THE STORY TELLER." This department will be unusually rich. Besides an abundance of Short Stories, two or three serials will be given during the year.

BUTTERICK'S NEWEST PATTERNS for ladies' dresses and childrens' dresses are given by special arrangement every month.

"THE LION IN LOVE," and **"THE INTERRUPTED READER,"** two large and splendid premium engravings. One of these is sent free to every subscriber.

\$2.50 a year is the price of "ARTHUR'S ILLUSTRATED HOME MAGAZINE." In clubs; 3 copies for \$6; 6 and one extra to getter up of club \$12; 10 and one extra \$20. 15 cents must be added to each subscription for prepayment of postage for the year. Specimen numbers 15 cents, in currency or postage stamps.

T. S. ARTHUR & SON, Philadelphia, Pa.

PETERSON'S JOURNAL

OF POPULAR LITERATURE.

ALL ARTICLES COMPLETE IN EACH NUMBER.

Messrs. H. Peterson & Co., well known through the country from their connection for many years with the SATURDAY EVENING POST, will shortly begin the publication of a First-Class Monthly Magazine, to be entitled PETERSON'S JOURNAL, and to be devoted to the most popular literature of the day.

PETERSON'S JOURNAL, the first number of which will be issued for December, 1874, will be the cheapest FIRST-CLASS MAGAZINE published in America—and will aim to furnish a greater amount of superior reading matter, in a more elegant form, than can be procured elsewhere for the same price. It will avoid all continued stories, the publishers believing that the breaking off of the narrative each month interferes with the enjoyment of the reader. Each NUMBER WILL BE COMPLETE IN ITSELF—and will present regularly a variety of popular stories and miscellaneous papers, written by some of the most talented authors of this country and England.

In order to give time for the publication of the new Journal to become known to our host of old friends throughout the country, the first number—that for December—will be ready early in October.

Terms \$5.00 a year. An extra copy will be supplied gratis for every club of five subscribers at \$3.00 each. The postage will be prepaid by the publishers, without extra charge, in accordance with the new law. Specimen copies 25 cents. No specimens sent gratis. Address,

H. PETERSON & CO.,
920 Walnut St., Philadelphia.

Five Thousand Good Books

for sale, at a discount of 30 to 60 per cent from usual prices. Our third Great Clearance List sent free.

ESTES & LAURIAT, Boston.

RARE OFFERS.

We offer the Ladies' Own Magazine From October '74, to January '76, with a beautiful chromo for \$2; or three months on trial for 25 cents

WE OFFER AGENTS \$2 CASH

Or \$1 in premiums for three names, and better still for larger lists. We send a sample of the chromo and the Magazine three months for fifty cents, to those who will act as agents.

The LADIES' OWN is the Queen of all the Literary, Family and Fashion Magazines. Try it a quarter and make up a club. Address LADIES' OWN MAGAZINE CO., 117 Nassau-st., New York.



Stevens' Patent Brecc-loading Pocket Pistols and Pocket Rifles, Sporting Rifles, and Shot Guns. Also the noted Hunter's Pet Rifle. Send for Circular.

J. STEVENS & CO., Chicopee Falls, Mass.

W. A. COVERT & CO., Produce Commission Merchants, No. 63 Pearl Street, New York. Quick sales and prompt returns. Send for our weekly Prices-current and Marking Plate.

"The Best and Cheapest Sunday-School Library."

GRAND CHEAP LIBRARY.

50 Choice Illustrated Volumes, 16mo., bound in Muslin, and not in any other Select Library.

This Library contains over 12,000 printed pages, illustrated by 212 large full page, fine engravings, and many of the smaller size.

All the volumes in this Library are valuable and instructive. The price of the Library is \$36.00, from which we make a discount of TWENTY PER CENT to Sunday-schools, making the

Net Price for Fifty Large Books, only \$20.80.

SOLD ONLY IN SETS.—Send for a complete Catalogue. Books of the size of these in this Library are usually sold at from \$1.00 to \$1.25 each. Nothing like this Library has been offered for such a small sum.

PUBLISHED BY THE

AMERICAN SUNDAY-SCHOOL UNION,

1122 Chestnut St., Philadelphia.—ALEX. KIRKPATRICK.
7, 8 & 10 Bible House, New York.—G. S. SCOFIELD.
40 Winter Street, Boston.—E. SHUTE.
98 Dearborn Street, Chicago.—W. R. PORT.
207 North Sixth Street, St. Louis.—S. PAXSON.

THE GREAT MUSIC BOOKS

For Conventions and Singing-Schools are

THE SONG KING.

By R. H. PALMER.

THE JOY.

By P. P. BLISS.

THE SONG ERA.

By F. W. ROOT.

The True Singing-School Text Book.

By A. N. JOHNSON.

Price of each, \$7.50 per Dozen.

Specimen Copy of either, 75 Cents, (post-paid, by mail. Published by JOHN CHURCH & CO., Cincinnati, O.

Clarke's

New Method for the Piano-Forte.

Endorsed by the Musical, Educational and general Press, and by Good Teachers, to be Beyond all Comparison the Best to be had at Book and Music stores.

Sent by Mail, Price, \$3.75.

LEE & WALKER, } 922 Chestnut St PHILADELPHIA.

New Church Music Book,

For 1874—1875.

THE LEADER!

By H. R. PALMER, assisted by L. O. EMERSON.

Just issued and ready for sale. Its success already assured. Its price is a return to anti-war Church Book rates, and its contents new, fresh, and cannot fail of winning a hearty endorsement from choir masters—the musical profession and the musical public. Specimen pages free on application.

PRICE \$1.38. \$12.00 PER DOZ.

RIVER OF LIFE.

FOR SABBATH SCHOOLS.

A sale of over 30,000 in less than one year attests the merit of this Book. The Publishers are confident that no better Sabbath School Book has been published in years, and none give such entire satisfaction.

Price 35 cts. B'ds; \$3.60 per doz.; \$30 per 100.

THOMAS'

SACRED QUARTETS and ANTHEMS.

This day published.—Has been many years in preparation and will be welcomed by all the lovers of Mr. Thomas' Sacred Music—and who is not one? As a Quartet Book for Choirs, it will be found indispensable.

Price in Boards, \$2.50. Cloth, \$3.00.

OLIVER DITSON & CO., CHAS. H. DITSON & CO., Boston. 711 B'dway New York.

ALL FOR ONE DOLLAR.

Wine, Wife and Song.....by Strauss.
A happy Circle Gallop.....Strauss.
La Fille de Madam Angot.....Waltz.
With Steam, Polka.....Ed. Strauss.
Let's be Gay, Waltzes.....J. Strauss.
Regatta Veneziana.....F. Liszt.
La Bella Louise, Quicksstep.....Strauss.
Where the Citrons Blossom.....Rubles.
Who is at my Window.....Osborne.
Annie Dear.....Abt.

Why throw away money on high-priced Music when you can select from our Catalogue of 700 pieces? Any 20 Half-Dime, or 10 of Dime Series, mailed on receipt of One Dollar. Sold by all booksellers, and can be ordered through any newsdealer. Send stamp for Catalogue.

BENJ. W. HITCHCOCK, Publisher, 355 Third Avenue, New York.

The Herald of Health

Sept., Oct., Nov., and Dec. numbers free to new subscribers for 1875, who send in their names immediately.

The September number, among other able articles, contains the following of great interest:

1. The Literature of Quackery.
2. Reform in Child Education.
3. Tent-Life in Summer.

This number will be given free ONLY to those who send in their names before Dec. 1st. The Oct. No. contains Dr. Clarke's remarkable article on

1. The Building of a Good Brain.

Also:

2. Mosaic Food Laws.

3. Headaches, How to Avoid Them.

4. The Physical Life of the Germans.

5. MALADIES CAUSED BY BOOTS AND SHOES.

Also, Crimping the Hair; Varicose Veins; Salt Rheum; Diet for Lean Folks; How to stop the Spread of Typhoid Fever; Gloomy Feelings; Insanity; Dandruff; Dyeing the Hair; Baldness; Bad Breath; Periodic Drunkenness; Funny Poems; Perils of Weakness; Girls' Rowing Match; Clean Water and Cow's Health; Care of the Eyes, etc., etc.

The Nov. No. contains a very remarkable paper by Herbert Spencer, on

The Cause and Cure of Evil.

And many other papers too numerous to name.

We give for \$2.00 premium:

No. 1. THE COMPLETE WORKS OF SHAKESPEARE,

in one large volume, with good type and paper, of over 1000 pages, and 36 illustrations. The most remarkable instance of cheapness we have any knowledge of.

No. 2. The Greatest Premium Yet.

For \$2.25 we send HERALD OF HEALTH and the great story

Robinson Crusoe.

Robinson Crusoe.

Robinson Crusoe.

In one beautiful volume, bound in cloth, gilt edges, and over 600 pages. Every child will be delighted with this offer.

CLUBBING RATES:

One copy, with both the above premiums, \$2.75; ten copies, with Shakespeares, 15.00; ten copies, with Robinson Crusoe, \$17.50; ten copies, with both the premiums, \$22.50.

HERALD OF HEALTH and Premiums No. 1 or No. 2, with any \$4 magazine, both post-paid, \$5.50; New York Tribune, post-paid, and Premium No. 1 or 2, \$3.75; Agriculturist, post-paid, and No. 1 or 2, \$3.00.

The HERALD OF HEALTH is the most substantial journal of its kind published, employing only the best writers. The Christian Standard says: "It is a great pet in our family, looked for with deep interest." The Christian World says: "It is the best magazine of the day," and the Scientific American says: "It contains more sensible articles than any magazine coming to our sanctum."

In case none of the above premiums are wanted, we will send either of the following, with the HERALD, for \$2.00:

How to Educate Yourself.

How to Make Money.

Both by GEO. CARY EGGLESTON,

Or,

How to Behave.

The latter is a perfect book of etiquette for the young.

These three books are handsomely bound in cloth. For \$3.00 we will send all the last named books and HERALD OF HEALTH. The books alone would cost \$2.25.

NOTICE.—In all cases send 10 cents additional for prepayment of postage on Herald for 1875. Samples 15 cents.

WOOD & HOLBROOK,
13 & 15 Light St., New York.

Eating for Strength.

This work, just ready, is a guide to eating, showing how to feed one's self or children, so as to get the best physical development. It is 4 books in one—1st, The Science of Eating. 2nd, Receipts for making healthy food. 3d, Multitudinous receipts for wholesome drinks. 4th, 200 questions answered. Price, by mail, \$1.00, or with HERALD OF HEALTH \$2.50.

WOOD & HOLBROOK,
13 & 15 Light St., New York.

AMERICAN AGRICULTURIST.

ORANGE JUDD COMPANY, Publishers, 245 Broadway, N. Y.
ANNUAL SUBSCRIPTION Terms (always in advance):
\$1.50 each for less than four copies: Four to nine copies, \$1.25 each: Ten to nineteen copies, \$1.20 each: Twenty copies and upward, \$1 each. 10 cents extra must be forwarded with each subscription, for prepayment of postage for 1875. Papers are addressed to each name.

☞ Either English or German Edition, at these prices.

SOMETHING Worth Looking Into By Every One.

Please Examine Carefully and Thoughtfully the Contents of this and next Pages; see what is said, and what is offered; it is eminently worthy of your attention.

To Do Good AND at the same time Make Money

is certainly desirable. Mere money making is a low pursuit—especially when what you gain some one else must lose. But when *your* gain is also profitable to friends and neighbors with whom you deal, it is very pleasing. This

Is Just What is Proposed to You in these Pages.

Two men, equal in physical and mental power, with equal advantages, commence together in any pursuit—in trade, commerce, manufactures, mechanics, farming, gardening, fruit-growing, stock-raising, or anything else. One uses what knowledge he has, and toils on early and late; he is neither idle nor lazy, but he depends mainly upon *work* alone. The second man does all this, but, *in addition*, he keeps his *ears* and *eyes* open; he picks up every item of information he can gather from the experience and practice of others, learning quite as much perhaps from their failures as from their successes. He not only takes time to go and see what others do and *how* they do it, but he carefully studies every written or printed scrap, showing *what* others are doing, *how* they do it, *how* and *when* and *why* they succeed, and how and when and why they fail. This knowledge he utilizes in his own business, and he *prosper*s, because he constantly

Makes the Brains Help the Hands.

The brute animal uses his muscles only; the human animal reasons and studies *how* he can use his muscles, his toil, to the best advantage. By so much more as a man cultivates, develops and uses his *thinking* power, by so much more does he rise above not only the brutes, but

above his fellows who depend almost entirely upon their physical efforts—their hard work.

A Bit of History, and what came of it.

Nearly 40 years ago, a Young Man, brought up to hard work on a Western stumpy farm, had finished sowing three of four adjoining 10-acre wheat fields, all similar in soil, etc. While his team was resting at eventide, he pored over books and papers, and catching at an item, he took a lantern, went to the barn, made a solution of tar and water, wet the remaining wheat seed in it, and the next morning dried it off with slaked lime, and sowed it on the fourth field. The result was, an *excess* of over 5 bushels *per acre* of nice plump wheat on the last 10 acres, which sold at \$1.12½ per bushel. The tar cost about 25 cts. This single *hint*, gathered from *reading*, gave him at least

\$56.25...for 25 Cents.

This led him to figuring upon the *profit* of *studying* into the experiences of *other* people. He reasoned that if two millions of the farmers of our country should read enough to each get and turn to account only one such hint, in the course of a year, there would be an aggregate

Gain of \$113,000,000!

He saw at a glance that if every tiller of the soil, every mechanic, etc., would only be on the sharp lookout for information, and could directly or indirectly learn what others were doing, and *how* they were doing, it would *add greatly* to the *profit* of each one's labors. He further saw, that as few men have time or money to travel round, it would be of *great advantage* if some one would *gather up* a mass of *useful, practical* information, *print* it, and *scatter* it among all others of *like occupations*. But to do this *well*, the person doing it must himself be educated by *work*, by *practice*, by a good deal of *observation*, and by study and discipline of his own mind.—His ambition was stirred to do something in this direction, and he began studying night and day, as far as necessary farm work would allow; he disciplined his mind to *right* thinking and reasoning, by hard study of mathematics, languages, etc.; he went through the best Seminary, and then the best College course he could; he traveled many hundreds of miles on foot through different parts of the country, to see *how* different men practiced. He afterwards shut himself up in one of the best Laboratories in the country, to study out what aid could be got from chemistry and other sciences in regard to soils, manures, food of animals, etc., etc. He at the same time attended Medical and other lectures, to learn something of the use and *misuse* of medicines, etc. He had scarcely gone through this course of study, and learned enough to know that many of the pretended discoveries in agricultural science were unreliable, when he was earnestly invited to New York to help edit a Journal that had been struggling along for ten years. This was over twenty one years ago. Shortly after he invested his all in purchasing the Journal, so that he could manage it according to his own views of

what was needed. He laid out his plans, and has since followed them, as detailed below:

1st.—To popularize the Journal by adapting the reading to the wants of the *entire family*—in Country, Village and City.

2d.—To print nothing that could lead anybody astray, even if he had to leave out nine-tenths of the sensational items that so often filled newspaper columns, and even if he should sometimes be styled "old fogey," as was done.

3d.—To call to his aid the *best practical men and women*, and to get the *best sifted* information, at *any cost*, not only that the Journal should have powerful aid, and in great variety, but so that it would go on as a permanent institution, should he himself fail in health or life. In fact, the paper was organized to run independently of himself, if need be. At its helm was placed Dr. GEORGE THURBER, one of the most practical men of our country, *thoroughly informed in all departments*. As assistants were engaged such men as JOSEPH HARRIS, formerly editor of the *Genesee Farmer*, and the cultivator of a large farm in Western New-York, whose "Walks and Talks," detailing his own daily experiences, his successes and failures, have been everywhere useful; GEORGE E. WARING, JR., whose works and writings are widely known, and who cultivates a large farm in Rhode Island. With these are the quaint and practical TIMOTHY BUNKER, Esq., HENRY STEWART; PETER HENDERSON, the eminently successful gardener; Hon. FREDERICK MUEHLEN, of Missouri, and many others whose teachings, given from their *practical experience*, are held in the highest esteem by all who know them. The *House-keepers and Childrens' Department* have the aid of FAITH ROCHESTER, AUNT SUE, and others. All these, and *many others*, including hundreds of correspondents all over the country, have long given their *best thoughts* to this Journal, and *still do so*.

4th.—To edit the Advertising Columns as well as the reading matter, and shut out all advertisements of Patent Medicines, all secret things of uncertain value, all *unreliable* persons and dealers, etc., so that the *WHOLE PAPER*, even to its advertising columns, should be *entirely trustworthy*.

5th.—To investigate and expose the various *Humbugs* that prey upon the ignorance of country and city. This department has shown up 2,000 swindles, and saved the people millions of dollars.

6th.—To supply the Journal at the bare cost of printing paper and press-work, depending upon future good advertisements to pay other expenses, and supply any reasonable profit, etc.

7th.—To push the paper into the hands of the great mass who would be benefited by it.

☞ As experience, facilities, and means increased, the scope of this paper has been further enlarged to meet the wants of the entire country, especially as a *FAMILY JOURNAL*. The Engraver's art has been called in, and Illustrations which teach so much more and faster than mere printed words can do, have been largely introduced—not ink daubs, but finely cut, beautiful pictures, executed in the highest style of the art.

The Result.

The above Journal, still called by its original name, the "*American Agriculturist*"—though having now a *far wider range* than is implied in its mere name—has found a hearty welcome everywhere, not only in the Country, and Cities, and Villages of every part of the American Continent, but it circulates largely in Australia, and in the Islands of the Pacific, in distant Asia, along the coast and northern regions of Africa, away in Russia, and elsewhere throughout Europe. For seventeen years it has been is-

...sued in separate English and German Editions, each containing similar illustrations and reading matter, and supplied at the same price. It

Exactly Meets THE People's Wants.

It gathers, sifts, and condenses a vast amount of reliable information for the "Farm," the "Garden," and the "Household," both for Village and City people.

Its Suggestions have set tens of thousands of people on the road to profit.

It has saved the people at large from millions of dollars of loss by explaining the tricks and wiles of specious swindlers.

It gives every year at least 500 BEAUTIFUL and INSTRUCTIVE ENGRAVINGS, costing \$8,000 to \$12,000, and every reader has perfect copies.

More than \$25,000 are expended every year in collecting and preparing the best and most useful information, hints, and suggestions, supplied by the experience and observation of practical men and women. (Indeed, it is hardly possible for any one, anywhere, to read this Journal a year, without getting some hint, that will directly or indirectly put many dollars into his pocket, or at least save many dollars of loss.)—Thousands upon thousands of persons have written, telling how its teachings have put money in their pockets, many times its cost. (These letters would fill many large volumes.)

Tens of thousands of Mechanics, Traders, Professional men, Factory-workers, etc., are now enjoying their pleasant garden-plots and yards, cultivated solely from the directions of this Journal.

It is of universal utility, containing hints and suggestions useful in every part of the world.

To Housekeepers everywhere it is of great value for its practical talks about all departments of home labor and care.

To Children and Youth it affords pleasing Pictures and entertaining and instructive reading.

With all the above, it is the Cheapest Paper in the world, taking into account its size, its beauty, and the great expense and care devoted to its preparation. (Every volume contains more reading matter than 20 ordinary Books which are sold at \$1 each.)

The PRICE per annum is only \$1.50, of U. S. Currency; four to nine copies are sent for \$1.25 each; ten to nineteen copies, for \$1.20 each, and twenty or more copies, only \$1 each! (N.B.—As the Publishers will pay the postage after Jan. 1, 1875, 10 cents in addition to the above terms must be sent with each subscription, to prepay this postage.)

(The Publishers will pay the postage by the ton weight, so that expense will be saved the subscribers by the new arrangement, and the Publishers will be able to enlarge the paper from time to time, without doubling the postage to the readers, as has hitherto been the case.)

To our Old Readers the Publishers beg to say, that while the long-time Managing Editor,

and his full force of workers, will continue as heretofore, the Old Editor has returned from a year's furlough, re-invigorated in health, and has disconnected himself from all other literary journals and pursuits, and will hereafter devote himself to this Journal, and the Publishers believe you will find the American Agriculturist not only better than ever before, if possible, but better and better, as time goes on.

To New Readers let us say, that we believe you will find great profit in reading the American Agriculturist a year. Try it! It will cost you but \$1.50, (less than 1/4 a cent a day, which is easily saved,) and much less if you get three or more others to join you in a club.

SPECIAL—ONE.—To each NEW Subscriber, who remits 25 cents extra (for mounting, postage, etc.) the Publishers will send, mounted, packed, and prepaid, a **BEAUTIFUL CHROMO**, viz: "Up for Repairs," or "Mischief Brewing," but the choice must be named at the time of subscribing.

SPECIAL—TWO.—Extra.—Every subscriber for 1875 (Vol. XXXIV) received in November, 1874, will be entered at once, and receive, without extra charge, the December number of 1874. Thus, those subscribing in November, 1874, for the year 1875, will have the paper 13 months for 12 months' price.—Those subscribing at any time for 1875, will get many times their money's worth in a year's numbers of this superb Journal. The hints of a single page are often worth far more than the price for a whole year.

To ALL, we say, for American Agriculturist,

**You are Invited
To Try it a Year,
And thus Prove its Value;
It will Pay You,
And Pay You Well.**

Send subscription price, single or club, with postage (10c.) by Check or Draft on New York Banks (or P. O. Money Order,) payable to the Publishers, or Registered Money Letters.
**Orange Judd Company, Publishers,
245 Broadway, New York.**

AND NOW
ABOUT
"Doing Good AND Making Money,"
ALSO ABOUT
Large Pay for Little Work.

I.—If by your solicitation you persuade another to take and read the American Agriculturist, you will do him a POSITIVE GOOD. This Journal will benefit him many times its cost—and the Publishers will reward you as follows:

II.—They have selected with great care, and collected a very fine assortment of very useful and very desirable articles, good for one's own use, or for ready cash sales. Every article is

first-rate—new, well made, direct from the chief manufactory of each. See List of them in the Table of Premiums, next page, and especially Descriptions and Illustrations of them on the following pages.—By large cash wholesale purchases, and by other favorable arrangements, the Publishers have secured these good articles on extraordinary terms and guarantees, and are thus able to supply them very advantageously, viz., they give them away to their friends, who cooperate with them in introducing this valuable Journal into other families—which can be done with little time or trouble, and for which the reward or pay will be large, as detailed further on. Some of the articles are given for obtaining as few as 3 subscribers at only \$1.50 a year.

N.B.—Their facilities for getting these good premium articles, referred to above, are such that the publishers can generally afford twice as much for getting subscribers, by giving these premiums, as they could possibly pay in cash, while the articles offered are just as good as so much money, or in most cases better than money, on account of their special value, and they can be readily sold for cash.

N.B.—Under similar, and even less favorable offers, many persons have canvassed for subscribers as a business, receiving the Premiums, and selling them for cash, and they have thus secured salaries ranging all the way from \$200 to \$3,500 a year, and this for working only part of the time. (We quite recently met a Mechanic on a steamer, who assured us that our paper, furnished him by one of our lady canvassers, had been worth hundreds of dollars. As she made over \$2,000 a year, by receiving and selling our Premium Articles for Subscribers which she obtained, she certainly "made money and did good" at the same time—and this is only one of many cases.) But

Any One Anywhere

can collect and send us few or many names of subscribers, and receive a corresponding article, (one or more of them,) from our Premium List. Some start for large premiums, but, being otherwise occupied, they stop at a few names, and take any article offered for the number of names actually obtained. Others have started for a small premium, and finding the work very easy, have gone on, and obtained one or more of the most valuable articles. Every name sent for a Premium List, if so stated at the time of sending, is credited to the sender, and he is supplied with any premiums his names are entitled to. **FURTHER**, while names should be sent in as fast as secured, so that the subscribers may begin to receive the papers, the canvasser can have any time desired for enlarging or completing a list, up to **July 1st, 1875**, but he can call for any premium he is entitled to at any time before, and it will be promptly forwarded. See "Explanatory Notes."

Easy Work.

The collection of subscribers is very easy, as the paper is so cheap and valuable, that almost all will take it, if it is brought to their notice and its value properly explained.

More than **Fifteen Thousand Persons**, Men, Women, and Children, in all parts of the Country, and in almost all stations of life, have been successful in securing from one to a dozen or more of these Premiums, and with general satisfaction and pleasure. As many as **1,000 to 1,300** subscribers have been sent from single Post-offices by our pre-

mium canvassers. There are few Post-offices where there are not families enough who ought to have the American Agriculturist, to make up half a dozen larger or smaller Premium Clubs.

Many LADIES have been successful in getting Sewing machines, and other household articles; others make their entire living by canvassing and selling the articles. Some are annually laying up money in this way. (We have canvassers, who have worked thus for a dozen years or more.)

Many BOYS and GIRLS have been quite successful in securing Dictionaries, Melodeons, and many other articles for themselves, and for presents.

SCHOOLS often unite their efforts and secure Melodeons for their rooms, teacher's presents, etc.

CLERKS in Stores, Post-Offices, etc., have excellent opportunities, and many of these have obtained Watches and numerous other good articles.

Many MARRIED MEN have quietly gathered clubs of subscribers, and surprised their wives with a Sewing Machine, articles of Silver Ware, etc.

Many YOUNG MEN have done the same thing for female friends.

MEMBERS OF CHURCHES have united their efforts in making up clubs of subscribers, and obtained Sewing Machines for the Pastors, Melodeons for the Churches, or Sunday School rooms, etc.

Many SOLDIERS' WIDOWS, and poor Tailors, have received Sewing Machines for clubs raised by a few kind hearted neighbors.

FARMERS' LIBRARIES have been obtained for common use by the combined efforts of a few persons in a neighborhood, who have made up a premium club of subscribers, and received our Rural Books.

AGRICULTURAL SOCIETIES have subscribed for a premium club, giving the paper out as premiums to exhibitors, and received a Reaper, a Melodeon, or other article, from us, exhibited it at the Fairs, and then sold it at auction. Sometimes they raise subscriptions among members, and turn over the money received for the sale of the premium to the general fund.

MERCHANTS often make up clubs in their stores, and obtain the premiums for themselves.

MERCHANTS, SHOE-MAKERS, TAILORS, and others, have subscribed for a whole premium club, given a subscription to any customer buying \$10, \$15, or \$20 worth of goods, and retained the premiums themselves.

And NOW

Let us look at some of the Premiums which are offered. The next Table tells the name and cash price of each article, and, (in the last column but one), gives the number of names sent in at the regular price of \$1.50 a year that will secure any premium article. (The last column gives the number of names at the lowest club price for 20 or more names, that is \$1 each. Some persons quickly raise large clubs by taking all the names at \$1 each, and themselves pay the difference, 50 cents each, and thus get the premium articles very cheaply.)

Explanatory Notes. N. B.

Read and carefully Note the following items: (a) All subscribers sent by one person count, though from several different Post-offices. But....(b) Tell us with each name or list of names sent, that it is for a premium....(c) Send the names as fast as obtained, that the subscribers may begin to receive the paper at once. You can have any time you wish up to next July, to complete your list....(d) Send the exact money with each list of names, so that there may be no confusion of money accounts....(e) Old and new subscribers all count in premium clubs, but a portion, at least, should be new names; it is partly to get these that we offer premiums to canvassers....(f) Specimen Numbers, etc., will be supplied free, as needed by canvassers, but they should be used carefully and economically, and where they will tell....(g) Remit money in Checks on New York Banks or Bankers, payable to

order of Orange Judd Company, or send Post-office Money Orders. If neither of these is obtainable, Register Money Letters, affixing stamps both for the postage and registry; put in the money and seal the letter in the presence of the Post-master, and take his receipt for it. Money sent in any of the above ways is at our risk; otherwise it is not.

Table of Premiums.

[In the following table is given the price of each article, and the number of subscribers required to get it free, at the regular rates of \$1.50 a year, and also at the club rates of \$1 a year.] Description of Premiums on next pages.

Table of Premiums and Terms For Volume 34-(1875). BEGINNING NOW. Open to all-No Competition. Includes list of items like Tea Set, Ice Pitcher, Casters, Cake Basket, etc., with prices and subscriber requirements.

Holder—tasteful enough for the most stylish mansion—all beautiful, of uniform design, late pattern, with raised and embossed figure work. They are none of the common cheap silver-washed stuff that will look finely so long as unused, but are the best triple-plate on white metal. (See notes on plated ware, just below.) For all practical purposes, and for ornament, they will be as good as solid silver, for years. No Premium we have



Premium 1

supplied has been more commended than these articles in premiums 1 to 10. This No. 1, (and the others also), afford to a multitude of persons a rare opportunity to get beautiful and useful articles for home use and for marriage and other gifts. It will be comparatively easy to collect names of subscribers enough to secure one or more of these articles. A large number of persons have done so. JUST HERE, we append

A few Hints about Silver Plated Ware.

By the Electro-process it is possible to spread a single silver dollar over hundreds of square feet of surface, and cover it so perfectly that nothing but pure silver will be seen, but the thin film quickly wears off. By the same process continued, the silver coat may be put on to any desired thickness. It will be seen, then, that the real value of plated ware depends mainly upon the honesty and integrity of the manufacturer. We would hardly take as a gift much of the plated ware sold in the general market. Some of those articles can be bought very low, but they are very dear. As a security to our readers, and for our own good name, we get all our silver ware premiums from the LUCIUS HART MANUFACTURING COMPANY, 4 & 6 Burling Slip. They warrant each article supplied to us to be the best Triple-plate, such as we have ourselves used many years with great satisfaction. N. B.—These articles are also made of a strong white metal base, so that if by accident, or long hard use, the heavy silver plate should wear off at any point or corner, it shows very little. The late LUCIUS HART, the "Veteran Sunday School Man," was engaged in the same place and business for nearly a quarter of a century, and we know he cared more for good repute and integrity than for profit. The Company which bears his name, (and includes some of his family), we believe to be actuated by the same high motives, with a determination to sustain his high reputation, and we feel great satisfaction and confidence in supplying premium articles manufactured by them, and we believe we do our readers a favor in offering them these articles, viz—Premiums 1 to 10.

No. 2.—Ice (or water) Pitcher.—(See Engraving.)—A large highly Ornamental Article, that will adorn the table, as well as serve a very useful



Premium 2

purpose, and last many years, with no danger of breakage. It is of the same make, same metal, plating, etc., as No. 1.—For 32 subscribers, at \$1.50 each, we will send the Pitcher and a round Salver, of pattern to correspond, (value \$21.00).—For 44 subscribers we will send the Pitcher and a large 16-inch Oval Salver (value \$30), which is large enough to hold the Pitcher and two

Every Premium article is new and of the very best manufacture. No charge is made for packing or boxing any article in our Premium List. The Premiums, Nos. 12 to 18, 22 to 26, 29 and 30, 33 to 43, and 59 to 90, inclusive, will each be delivered FREE of all charges, by mail or express (at the Post-office or express office nearest the recipient) to any place in the United States or Territories.—The other articles cost the recipient only the freight after leaving the manufactory of each, by any conveyance desired. See Descriptions Following:

PREMIUM No. 1.—A splendid Tea Set of six pieces, full size, viz.: a Coffee Pot, a Tea Pot, a Sugar Bowl, a Cream Cup, a Slop Bowl, and a Spoon

goblets.—For 51 subscribers, we will send the **Pitcher**, the **Oval Salver**, and a pair of beautiful **Goblets**, silver without, and *gold-plated* inside, (value \$37.00). This *Complete Set* is exceedingly desirable, though the Pitcher alone, or that with the Round Tray, or the large Oval Salver, will answer well for *use or ornament*.



Prem. 3

No. 3.—Casters.—A handsome pattern, richly chased, containing four casters and mustard bottle—useful, necessary, ornamental for every dining table. The engraving does not show its full beauty. It is from the same makers, and of same metal and plating, as No. 1.

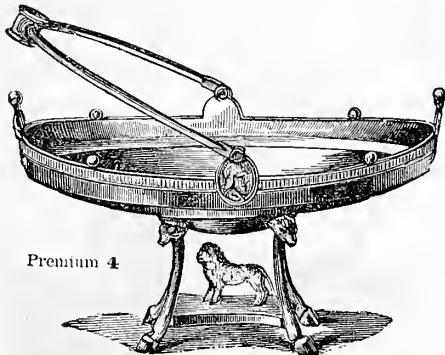

Premium 4

No. 4.—Cake Basket.—An elegant pattern, oval-shaped, nicely chased—a very taking, *useful*, and *beautiful* table ornament—is just the thing every one wants. From same makers and same metal as No. 1.

No. 5.—Revolving Butter Cooler.—(See Engraving.)—This is a really good and useful article, as well as an ornamental one. It is so arranged that a very little ice in the holder under the plate will



Premium 5

keep butter cool and fresh for a long time on the table, even in the hottest weather. The cover revolves, turning underneath the plate, out of sight when the butter is wanted, or over it as shown in the engraving, to protect the butter. The bright surface reflects outside

warmth, and prevents radiation, thus keeping the butter cool. The whole is in four pieces, which can all be taken apart for washing. Same metal, from same House as No. 1.

No. 6.—One Dozen Tea-Spoons.—**No. 7.—One Dozen Table-Spoons.**—These are "figured tips," *Olive-leaf pattern*, all of the same metal, plating, etc., and from same makers as No. 1. They are as beautiful and as serviceable for years, as solid silver spoons. See notes above about plated ware. These spoons are far *cheaper* than any others we have found at half the price, and *are well worth canvassing for*.

No. 8.—One Dozen Table-Forks.—*The same description and remarks apply to these as to No. 6.* We select as Premiums only such articles as we can warrant in quality and price, and such as are serviceable.

No. 9.—Child's Cup.—(See Engraving).—A beautiful gift for the Little One. Triple-plated on the outside, and *gilded* on the inside. It never breaks, and will last for many years—indeed, be a *life-keepsake*. Obtain only 7 subscribers, (as noted in Premium Table, page 435.) and you can secure one of these beautiful cups for your own child, or a name-sake, or other favorite.



Premium 9

No. 10.—Child's Knife, Fork and Spoon.—This is also a beautiful gift for a child. The articles are triple-plated, finely figured with *ivy-leaf pattern*, and put up in a *handsome silk-lined morocco case*.

All of the above ten Premiums are made and warranted as represented, the best triple-plate on white metal—by the LUCIUS HART MANUFACTURING COMPANY, referred to in the notes about Plated Ware on page 435.

No. 11.—Moore's Floral Set.—This is a beautiful Premium—a complete set of **Ladies' or Children's Garden Tools**, for the cultivation of flowers, consisting of a *Floral Hoe, Spade, Fork and Rake*, (as shown in the engraving). They are made of the *best steel and iron*, with finely polished *hard-wood handles*, light, durable, and highly finished, and each set inclosed in a box. They will be found very convenient in the garden and greenhouse. They are *useful* pleasing toys for the little folks, requiring only 3 subscribers to get

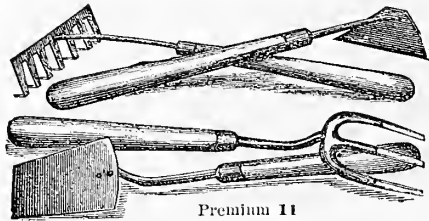

Premium 11

them free. Better get more subscribers, and secure half a dozen sets, or more, for others to come with yours, as they can all come cheaply as freight. Made by the MOORE MANUFACTURING COMPANY, Kensington, Conn.

Nos. 12, 13, 14.—Gold Pens: with *ever-pointed Pencils, in extension, coin-silver cases.*—(The engraving shows the different parts of the pen, holder, and pencil. The pencil portion contains a magazine of black lead points.—Premium No. 12 contains the best No. 4 Gold Pen; and No. 13 the best No. 6 Gold Pen, which is the same style, but larger. No. 14 contains No. 7 Gold Pen, in Gold-tipped Ebony Holder. *Each pen will be sent in a NEAT LEATHER CASE by mail, post-paid.* (When ordering, please indicate whether a *stiff, or limber, or medium* pen is desired. If desired, after trial but not use, a pen can be returned by mail, registered, and exchanged for one of different stiffness, by enclosing 3 cents for postage on exchanged pen. These pens are

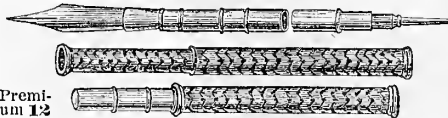

Premium 12

made by G. F. HAWKES, 66 Nassau St., and have obtained an excellent reputation. We have known the maker and his goods many years, and highly recommend them.

No. 15.—Ladies' Fine Gold Pen, in *Rubber Case, Gold Mounted*, with *Screw Extension*, and *Gold Ever-pointed Pencil*. A beautiful present for a lady teacher or friend. From the same maker as No. 12.

Nos. 16, 17.—Paragon Patent Revolving Pencil.—This is a beautiful Pocket Pencil, which is extended or closed by pulling or pressing the head. The engraving shows the pencil closed for carry-

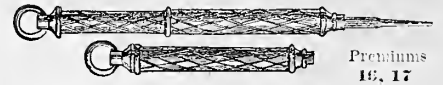

Premiums 16, 17

ing suspended from a chain if desired; also shows it opened for use. Simply pulling the ring, lengthens the case, and throws out the pencil. They are made with great care, and every Pencil warranted to work perfectly. They are *gold-plated*, and will last for years. We offer two patterns, one for ladies, with ring for chain, at \$1.50 each, and one of heavier and firmer plate, at \$3. From same maker as No. 12. Only 4 or 8 subscribers required.

No. 18.—Payson's Indelible Ink, and Briggs's Marking-Pen Combination.—(See Engraving.)—Payson's Indelible Ink is too well known to need further commendation. It is almost indispensable in the family. Briggs's Marking-Pen has been before the public for fifteen years, and is justly celebrated for all kinds of marking, and particularly for writing upon coarse fabrics. The Pen and Ink bottle are put up in a neat box-wood case; the glass pen joints in the middle and fits inside the case. The whole is thin, portable and always ready for use, and protected from injury by evaporation or breakage. We have used this pen and ink for several years with entire satisfaction.



Premium 18



Premium 19

No. 19.—Child's Carriage, or Perambulator.—An elegant carriage, handsomely finished, upholstered with *seps*, has full plate *tinmed joints, handle tips, side lights, dash rail, panel body, and carpet* on the bottom—all well made. A beautiful thing for use, or for a Gift, or for Sale, and easily obtained *free* by a few evenings' canvass. These carriages are from the well-known manufacturer, C. W. F. DARE, 47 Cortlandt st., N.Y.

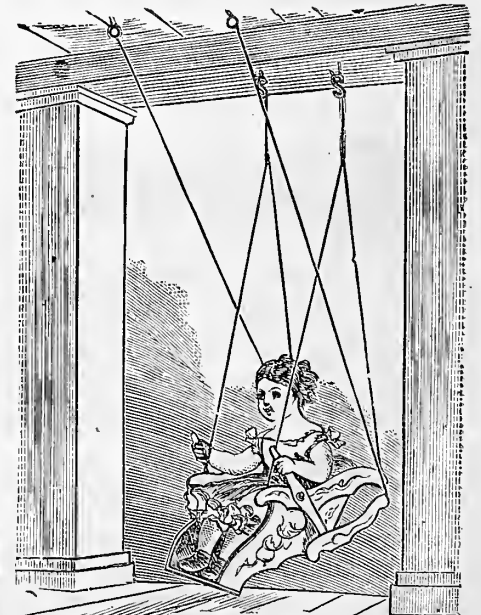

Premium 20

No. 20.—Child's Patent Propeller or Self-Operating Swing.—A pleasing thing for

a little boy or girl. The seat of the swing is upholstered with enameled cloth, showily painted, and hooks and all complete accompany it—ready to be suspended anywhere, where the four hooks can be driven over-head. When it is hung up, the hooks over-head to which the lever ropes are attached, must be set about one foot in front of the hooks to which the main ropes are attached. A child is delighted with being able to swing himself by simply pulling and pushing the handles. Nine subscribers easily obtained in an evening or two, will secure one free. From C. W. F. DARE, 47 Cortlandt St., New York.

No. 21.—Doll's Cottage Chamber Set.—Eight pieces of furniture, prettily painted: *Bedstead* (size 11¼×18 inches), *Bureau*, *Table*, *Commode*, *Towel-rack*, *two Chairs*, one *Rocking-chair*. Will occupy and please the little Girl, and give her early lessons of order in housekeeping. A free set requires only a dozen subscribers. Many Boys can each collect twelve subscribers, and get this Premium as a present for a little Sister or Cousin. We have many successful little canvassers. Made by C. W. F. DARE, 47 Cortlandt St., N.Y.

Premium 21

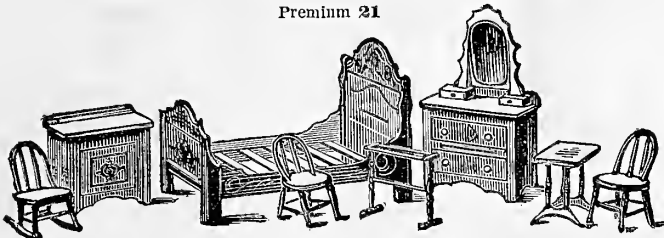

No. 22.—Crandall's Improved Building Blocks furnish a most attractive amusement for children. Churches, Dwellings, Barns, Mills, Fences, Furniture, etc., in almost endless variety, can be built with them, and the structures remain so firm as to be carried about. For developing the ingenuity and taste of children they are unequalled. The Blocks are put up in neat boxes, accompanied by a large *Illustrated Sheet* giving various designs of buildings, etc. This is one of the most successful toys ever invented.

No. 23.—Crandall's Masquerade Blocks.—These are put up in boxes; the blocks in each box will make, by various combinations, 300 different pictures in brilliant colors. They are not injured by washing, and afford endless amusement for children. They are very beautiful gifts for the little ones.

No. 24.—Crandall's Acrobats.—The most attractive, amusing and wonderful Toy of the age. Children everywhere, who have seen the Acrobats, are delighted with them. Thousands of figures can be made from the pieces in a single box. The pieces are variously colored, and there is no end of fun in a box of them. If you take your premiums in other articles, don't fail to buy the children a box of these Acrobats. Most dealers in Toys are getting them, as fast as they can be supplied. The manufacturers are now making and selling about 1,500 boxes a day, so popular is this new Toy and so great is the demand for it.

No. 25.—Pocket Tool Holder.—(See Engraving.)—Every boy (or man) will be glad to get hold of this Premium. We have kept a similar, but less



Premium 25

perfect set in use many years, and found it very convenient for a thousand little jobs. In a maple handle, which is hollow, with a lignum-vite head, are packed twenty miniature cast-steel tools, any one of which may be quickly adjusted to the handle. It will also grasp and hold for using anything from an 8-inch mill-file to a cambric needle. These are made for us by the MILLER'S FALLS MANUFACTURING Co., 78 Beekman St., New York.

No. 26.—Bracket Saw.—(See Engraving.)—Although this is a little thing, size of frame being about 6×12 inches, it is sufficient for the manufacture of very many ornamental and useful articles, as Book Rests, Brackets, Boxes, etc., which the ingenuity of any person, young or old, may devise. The frame is rosewood highly polished, and the saws of tempered steel, four of which, with *Designs and Directions*, are sent with the frame. The Boy (or Man) will spend many an hour with this, which might be worse employed, and not only develop ingenuity and skill, but also turn out useful and or-

naimental articles. We have seen a humble Parlor wholly adorned with brackets, frames, shelves, etc., which were mainly prepared by father and son from the wood of cigar boxes, with some from cedar and other shingles, and thin boards. The room was as attractive and pleasing to us under the circumstances, as some other drawing-rooms furnished with costly brackets, etageres, etc., at a cost of many hundreds of dollars. Four subscribers only will secure this Bracket Saw free. Made by the MILLER'S FALLS MANUFACTURING Co., 78 Beekman St., New York.

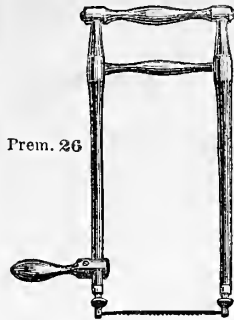

Prem. 26

No. 27.—"People's Pump."—(See Engraving.)—What most country families need. An indoor Force Pump for 1¼ inch Suction Pipe; capacity 15 to 18 gallons per minute. These pumps are tested to 150 pounds pressure, and will throw water from a hose pipe 50 feet high, and 80 feet horizontally. Being operated by a side shaft entering through the air-chamber, there is no piston rod to wear out brass stuffing box as in other pumps. They are among the most powerful, simple, and durable pumps to be had. The ease with which any part can be renewed in case of accident, or access had to the interior for repairs, commends them for greenhouses, farmers, and stockmen, as well as for city use. Awarded Medal of American Institute, as the Best Force Pump of all exhibited, Nov. 15th, 1873. None genuine without "People's Pump, Patented Aug. 31st, 1869," cast on the lid. Send for a descriptive circular to W. S. BLUNT, MANUFACTURER, 77 Beekman St., New York, and secure a free one through us for your own use, (or for sale at \$12.) by simply sending us 19 subscribers, which you can readily collect during a very few evenings or rainy days.

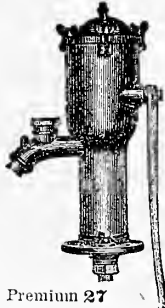

Premium 27

No. 28.—Non-Freezing Out-door Force Pump.—This is another style of the popular "People's Pumps," and by the same manufacturer. The description of Premium No. 27, is also applicable to this, and while that is designed for in-door, this is for out-door service. For seven additional subscribers at \$1.50 each, we will send, with either of the above pumps, four feet of hose, with couplings, and brass hose-pipe, price \$3.

No. 29.—Excelsior Pocket and Dissecting Microscope.—(See Engraving.)—The microscope reveals to us a beautiful world unseen by the unaided eye, and hardly conceived of, until one has the microscope before him. One of these instruments (the best obtainable) ought to be in every family, in country and city. It will furnish rational amusement for old and young, diverting the mind from baser pleasures, enlarging the conception of the skill and wisdom displayed in creation, to say nothing of its usefulness in examining and detecting a multitude of noxious insects. We have long sought an instrument of this kind that, while complete enough to be of any use, would be cheap enough for general introduction. That which we now offer, though not having the power and appliances of one costing \$20 to \$100, or more, is yet very valuable and serviceable for the price, and the best we can obtain for any

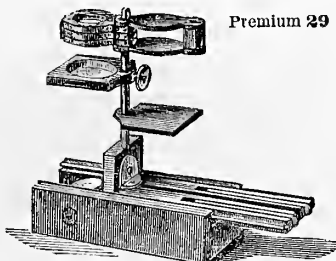

Premium 29

thing like the cost of this, and we are happy in being able to supply such an instrument free to every one, sending us barely seven subscribers. (Each of the subscribers

will get many times his money's worth in the paper itself, while the canvasser will have his microscope free, and can use it in interesting the others. So in this case, as with all the premiums, the canvasser will "Do Good and Make Money," or get what is as valuable as money, or more so.)—The Premium Microscope (shown in the engraving,) is supplied with three Lenses, and is packed in a neat case for the pocket. It is patented by J. T. Bausch, of Rochester, N. Y., and is manufactured by the VULCANITE OPTICAL INSTRUMENT Co., and it is for sale by the dealers in optical instruments generally.

No. 30.—Pocket Soap Bubble Toy.—We enjoy seeing children blowing soap-bubbles. There is much philosophy involved in the whole operation, besides the skill of manipulation—but we must leave the Children's Editor to discuss the "philosophy" of it in the Children's Columns. The little toy offered is much superior to the clay pipe, and will greatly please all the boys and girls. Two of these toys will be given for this premium, and almost any child can readily get 3 subscribers at \$1.50 each, and thus secure one of these for himself, and another to give away. It may be carried in the pocket, and can be used for blowing bubbles indoors or out. Directions accompany each one. Manufactured by S. B. BLISS, 34 Barclay street, New York.



Premium 30

No. 31.—Turn-table Apple Parer, Improved.—(See Engraving.)—**No. 32.—Climax Apple Corer and Slicer.**—**No. 33.—Family Cherry Stoner.**—All the above machines, which are most useful in every household where apples and cherries are to be cared for, are manufactured by D. H. GOODELL, Antrim, N. H., and 99 Chambers street, New York. We have never seen the work for which these machines were contrived, more rapidly or better done, than they will do it. The Apples are pared, cored, and sliced with the greatest facility, and the Cherries are readily relieved of their stones, leaving the fruit in good shape. Only three subscribers are re-

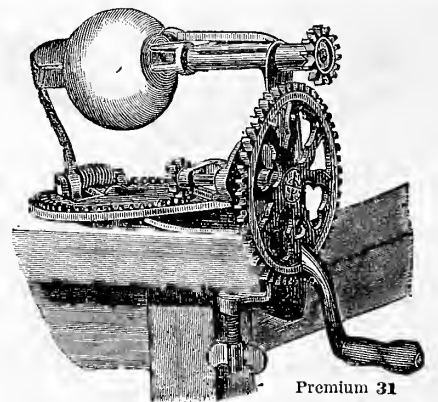

Premium 31

quired to get any one of these, or nine subscribers for the whole of them, free. See Premium Table.

An Illustrated Supplement

containing full descriptions of all our Premiums, 1 to 90, will be sent free to all applicants. We have room here for only Nos. 1 to 33. We ask each of our Old Readers to kindly call attention to this fact, and either to raise a club of subscribers, and secure one of these useful and valuable Premiums for himself, or put some friend or neighbor in the way of doing the same. It is Light Work for Good Pay.

THE TORSION SPRING

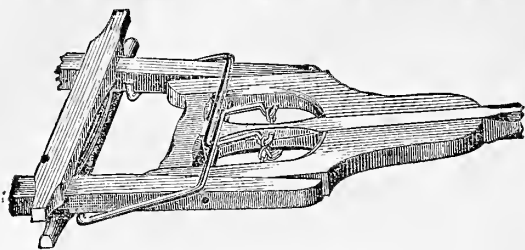

in its various applications as
**WAGON SPRING,
 SEAT SPRING,
 and
 TONGUE SPRING,**
 has been in use over Six Years, and for the last two years has obtained an enviable reputation wherever introduced. The principle of applying the elastic properties in the

Twist or Torsion of a Steel-Rod to mechanical purposes, has long been in familiar use as a door spring, but not to any great extent for other purposes till a recent date. Its simplicity, and the ease with which it can be applied to nearly all purposes, for which a spring is used, can not fail to produce an entire revolution in the manufacture of springs. It has been subjected to the severest tests, which were possible to apply, and has passed through the ordeal with a success gratifying and complete.

It was awarded the **First Premium and Medal** over the Elliptic and all other competitors, at the American Institute, New York City, in November, 1870. It is now being applied by the War Department to Government Wagons going on the Plains.

1. It occupies but little space.
2. It is light, weighing from 25 to 60 pounds complete.
3. It is sold very much lower than the common spring.
4. It can be applied to any kind of farm wagon, without change of construction.
5. A wagon will weigh from 400 to 1,500 pounds less, than when supplied with the common truck spring.
6. It can be instantly removed.
7. A wagon will last two or three times as long, when used with the **Torsion Spring**.
8. Twenty per cent greater loads can be carried by a wagon using it.
9. A horse can draw twenty per cent more on a wagon with this spring than without.
10. It never loses its elasticity.

SEND FOR CIRCULARS.
SCHENCK & SHERIDAN, General Agents, FULTON, OSWEGO CO., N. Y.
Or, ERIE TORSION SPRING CO., ERIE, PENN.

"The Opening of a Chest-nut Burr," the new Story, by Rev. E. P. Roe, author of "Barriers Burned Away," "What Can She Do?" &c., will be published in a few days by DODD & MEAD, 762 Broadway, in one large 12mo. vol. Price \$1.75.

**Lovejoy's New Style
 GLASS CUTTER
 And Putty Knife**

Cuts glass better than a diamond. Everybody should have one. Any child can use it. Sent to your address on receipt of 50c. and stamp by
ALVAN L. LOVEJOY,
 229 Washington St.,
 Boston, - - - Mass.
 Liberal Discount to Wholesale and Retail Dealers.

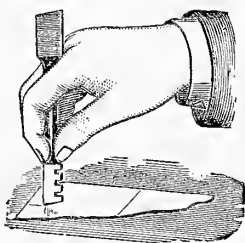

WANTED - AGENTS for the peoples' family ten pages, Rev. A. B. EARLE writes for it. An elegant premium. *Only \$1.00 a year.* Nothing like it for agents. One reports: "215 subscribers in 8 days," another, "82 in 11 1/2 hours;" another, "42 in 1 day." For terms, samples, &c., address J. H. EARLE, Boston, Mass.

GLASS CARDS Red, Blue, White, Clear & Transparent. Your Name Beautifully printed in GOLD! on 1 doz. for 50c. post pd.; 3 doz. \$1. Must have agents every where. Outfits 25c. Samples 3c. F. K. SMITH, Bangor, Maine.

DODD & MEAD

HAVE NOW READY:

I. A New Volume of
ABBOTT'S

AMERICAN PIONEERS AND PATRIOTS,

Captain Kid and the Early Buccaneers,

By J. S. C. ABBOTT.
12mo. Illustrated. \$1.50.

PREVIOUS VOLUMES OF THE SERIES:
 1. DANIEL BOONE.
 2. MILES STANDISH.
 3. FERDINAND DE SOTO.
 4. PETER STUYVESANT.
 5. KIT CARSON.
 6. DAVID CROCKETT.

II. A New Book by EDWARD GARRETT.

"BY STILL WATERS."

A STORY FOR QUIET HOURS.
Large 12mo. 12 Illustrations. \$1.75.

BY THE SAME AUTHOR:
 OCCUPATIONS OF A RETIRED LIFE. 12mo. Illustrated. \$1.75
 THE GREAT AND THE SMALL. 1.75
 PREMIUMS PAID TO EXPERIENCE. 1.75
 THE DEAD SIX. 1.75
 CROOKED PLACES. 1.75
 GOLD AND DROSS. 1.50

DODD & MEAD, Publishers,
762 Broadway, New York.

THE AMERICAN DAIRY SALT COMPANY,

SOLE MANUFACTURERS OF THE

ONONDAGA FACTORY FILLED

DAIRY & TABLE SALT,

AT SYRACUSE, N. Y.,

Respectfully call the attention of Dairymen and others to the quality of the salt now being manufactured by them. Having for many years past been engaged in perfecting the various processes for the manufacture of this salt, and by adopting the best modes and machinery for the purpose, they feel warranted in saying to the consumer that the article now produced is superior to any other either of foreign or domestic production. The following is a correct analysis of our salt and also of the celebrated Ashton's English Salt, made by Chas. A. Goessmann, Ph. D., Professor of Chemistry in the Massachusetts Agricultural College at Amherst, Mass.:

	Ashton Salt.	Onondaga Factory Filled.
Chloride of Sodium.....	97.65	98.28
Sulphate of Lime.....	1.43	0.91
Sulphate of Magnesia.....	0.05	.06
Sulphate of Soda.....	.00	.00
Insoluble matter.....	.05	.12
Water.....	.76	.60
	100.00	100.00

Circulars in regard to various tests made with this salt in comparison with the best foreign article, also certificates from a large number of the best dairies in the State as to its quality, may be had on application to J. W. BARKER, Secretary, Syracuse, N. Y., to whom orders for salt may also be addressed.

It is also for sale by the Agents of the Company in principal Western Lake Ports, by ST. JOHN & AVERY, 101 & 103 Broad St., New York; ROBERT GEER, 109 Pier, Albany, N. Y., and by Salt Dealers generally throughout the State of New York.

Inquire for *Onondaga Factory Filled Dairy Salt*.
 J. W. BARKER, Pres. & Sec'y,
 THOS. MOLLOY, Treas. Syracuse, N. Y.



Patent Concave Ox-Shoes.

The only forged ox-shoe made with concavity to fit hoof, and the best and cheapest.

GREENFIELD TOOL CO., Greenfield, Mass.

Patent Chemical Metallic Paints,

GROUND IN OIL and MIXED, ready for use, in cans, kegs, and barrels.

50 cts., \$1, and \$1.50 per gallon.

Also Liquid Slate and English Roof Paints,

ground in oil, 50 cts. to \$1.00 per gallon.

N. Y. CITY OIL CO., Sole Agents, 116 Maiden Lane, N. Y.

Send for Cards of Colors and Testimonials.

PRINDLE'S AGRICULTURAL STEAMER.



This Steamer has been fourteen years in use; the patent is extended seven years more. Its equal for durability, economy and safety has not yet appeared. We have the exclusive manufacture of them, and shall be pleased to hear from those in want. Circulars sent free. Prize essays on cooked food for stock forwarded, postage paid, on receipt of 20 cents.

BARROWS, SAVERY & CO.,

Philadelphia,

Manufacturers of Tinned, Enamelled and Plain Hollow-Ware and Saddlery.

J. C. HAND & CO., Factors, Philadelphia.

400 Acres on the Ocean for \$15
 per Acre. 1/2 to 1/4 cash, balance to suit purchaser. Will divide the farm. 1,500 Peach Trees, Berries of all kinds, etc., all of choice varieties. Combines fruit, truck, grain, and grass lands.
 A. P. BURNS,
 Snow Hill, Worcester Co., Md.

THE PATENT

ARION PIANO-FORTE

*Excels all others in Tone and Durability,
 and in Elegance of Finish they
 are Unsurpassed.*

These Pianos are used exclusively in the New York Conservatory of Music, and are recommended by the Profession and the Press throughout the United States.

Before purchasing, write for Illustrated Pamphlet, and mention the *Agriculturist*.

ARION PIANO-FORTE CO.,

No. 5 East 14th Street, New York City.

P A T E N T D E P T.

A M A G R I.

P A T E N T D E P T.

IMPORTANT TO INVENTORS.

American Agriculturist PATENT DEPARTMENT

In compliance with the request of numerous inventors, we have organized a

PATENT DEPARTMENT

in connection with this office for the transaction of all business connected with

Securing Patents

in the United States and foreign countries.

The character for

Reliability

which has been maintained by the AMERICAN AGRICULTURIST for more than thirty years will be carefully guarded in this as in other departments.

All Inventors

desirous of procuring patents at moderate cost are invited to forward (express prepaid) a model of their invention, with a brief description of its working. The model should not exceed one cubic foot in dimension. Upon receipt of model an opinion as to patentability will be given free of charge.

Preliminary Examination

at the Patent Office, to determine patentability, will be promptly made for a fee of \$5.

Litigation of Patents.

The services of the best counsel have been secured to prosecute or protect before the U. S. Courts and the Patent Office the claims of those intrusting their business to this agency.

Specifications, drawings, engravings, models, and all other appliances furnished at moderate prices.

In all dealings with this Department inventors may depend upon promptness, fidelity to their interests, and the best services which can be rendered by thorough experts. For full particulars, address

**AMERICAN AGRICULTURIST PATENT DEPARTMENT
 ORANGE JUDD COMPANY,
 245 Broadway, New York.**

P
A
T
E
N
T
S

P
A
T
E
N
T
S

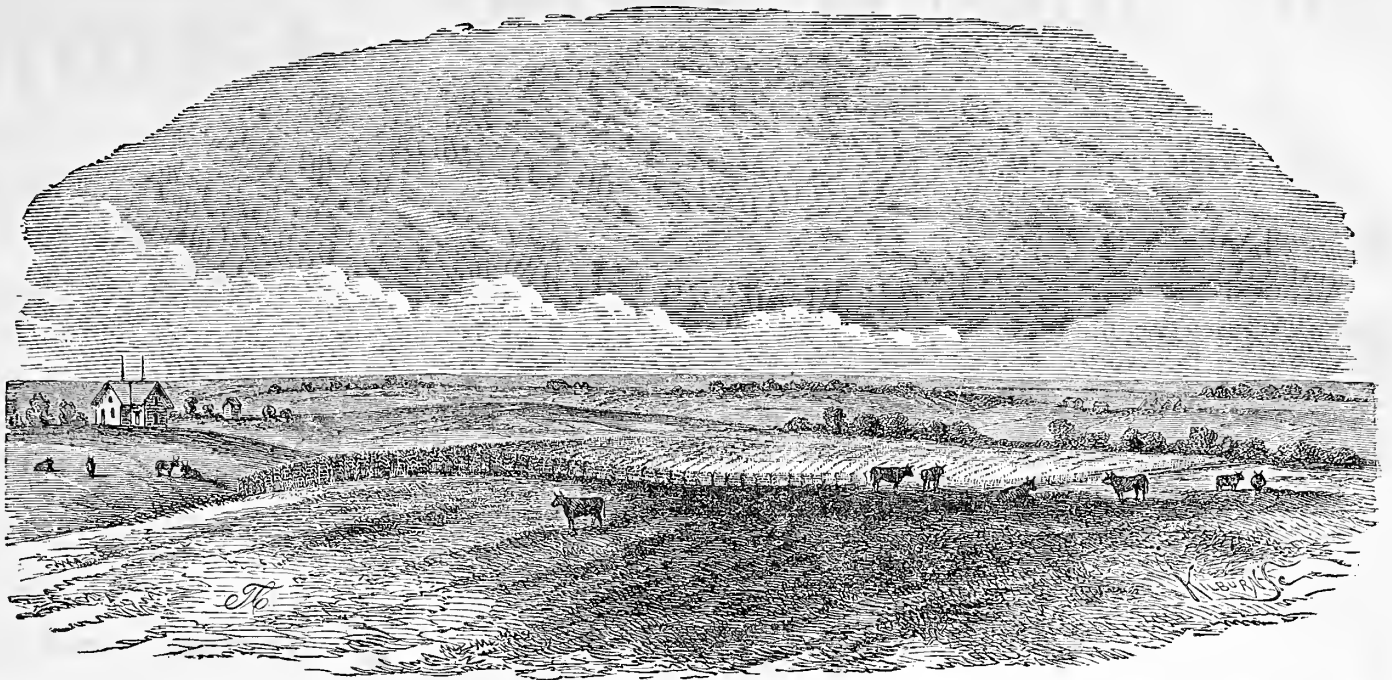

PRAIRIE, CORN-FIELD AND HERD OF CATTLE, SIX MILES WEST OF LINCOLN, NEB.

IF YOU WANT A FARM OR HOME,
 YOU SHOULD BUY OF THE
BURLINGTON AND MISSOURI RIVER RAILROAD CO.
 IN IOWA OR NEBRASKA.

- BECAUSE**—Their prices are low, ranging for the best land from Three to Ten Dollars per acre.
- BECAUSE**—No payments are required of the purchaser for four years, except interest at six per cent.
- BECAUSE**—After the fourth year only *one seventh* of the principal is payable annually till the whole is paid.
- BECAUSE**—You are not required to go into a wilderness, these being well-settled States, the population of which is rapidly increasing.
- BECAUSE**—The mildness of the climate and fertility of the soil is such that the settler can pay for his farm from the products raised upon it long before the time when the principal becomes due.
- BECAUSE**—Failure of crops from drought is unknown.
- BECAUSE**—Large allowances are made upon fare and freight, thus giving low rates on both to purchasers of this Company's lands.

AND YOU SHOULD BUY THIS YEAR.

BECAUSE—Purchasers of our lands in Nebraska during 1874 who cultivate one-half their land within two years from their purchase are allowed a *reduction of twenty per cent* on its price. **LARGE DISCOUNTS** also, FOR CASH, within One, Two, or Five Years.

Send for Circulars, with full information on all points, to

GEO. S. HARRIS, Land Commissioner,

At Lincoln, Nebraska, for land in Nebraska. At Burlington, Iowa, for land in Iowa.

Or to **W. D. COWLES, General Agent, 317 Broadway, New York.**

JAS. R. WOOD, General Agent, 59 Clark St., Chicago, Ill.

IMPROVED FOOT LATHES.

Small Engine Lathes, Small Gear Cutters, Hand Planers for Metal, Ball Turning Machines, Slide Rests, Foot Scroll Saws for light and heavy work, Small Power Scroll Saws, Foot Circular Saw Machines. The very best. Many readers of this paper have one of them. Catalogues free.

N. H. BALDWIN, Laconia, N. H.

Just the articles for Artisans or Amateurs.

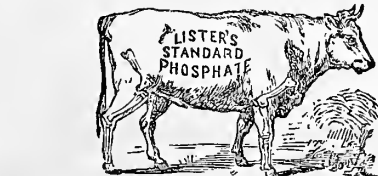

CELEBRATED FERTILIZERS.

Pure Bone Superphosphate of Lime. GROUND BONE, BONE MEAL, BONE FLOUR.

The large annual increase of the sales of these **Standard Fertilizers** is the best proof of their merits. Their freedom from adulteration, with every particle available for fertilizing, and the low price at which they are sold make it for the interest of every practical farmer to give them a fair trial.

LISTER BROTHERS,

New York Office, 159 Front St. Factory, Newark, N. J.

Farmers and Dealers are invited to send for Circular.

GENUINE
Peruvian Guano.
 In Large or Small Quantities.

Circulars, containing testimonials, references, and full particulars, mailed free on application to

R. BALCAZAR,

P. O. Box 129. No. 53 Beaver Street, New York.



Every Farmer,
 Every Breeder,
 Every Horse-Owner
 His Own Farrier.

Send for circulars to
GOODENOUGH
 HORSE-SHOE,
 Box 3,044, P. O. N. Y.
 Offices: 34 and 36
 Elizabeth Street.

P-E-T-R-O-L-E-U-M.
 CRUDE AND REFINED.

CRUDE PETROLEUM is unexcelled as a wash to preserve Fences, Shingle Roofs, Agricultural Implements, and wood of any kind, from decay, and Metal from rusting.

REFINED PETROLEUM for light is safe, pure, of standard legal test, and cheap.

Save two or three commissions by ordering one barrel or fifty direct from the Oil Regions of Pennsylvania. Address a reader of the *Agriculturist*.

GEO. M. LYONS, Titusville, Pa.

LOVEJOY'S METALLIC
WEATHER HOUSES

Indicate the changes in the weather, and are pretty mantle ornaments. The little lady appears in fair and the man in stormy weather, and they never make mistakes. Sent prepaid to any address, safely packed, upon receipt of \$2 (Two), by **ALVAN L. LOVEJOY,** Proprietor and Manufacturer, 229 Washington St. Boston. *Special price to dealers.*



Wm. Gillett
STEEL PENS!
 Sold by all Dealers.

No. 91 JOHN ST., NEW YORK.
HENRY HOE, Sole Agent, JOSEPH GILLOTT & SONS.

\$100 to \$200 per month guaranteed to agents everywhere, to sell our **Indestructible White Wire Clothes Lines.** Sample free. Address the **Hudson Wire Mills, 128 Maiden Lane, N. Y.,** or 18 Clark St., Chicago, Ill.



Established 1858.

TRADE MARK PATENTED.

The best and cheapest Paint in the world for Iron, Tin or Wood. For sale by the Trade everywhere. **PRINCE'S METALLIC PAINT CO.,** Manufacturers, 96 Cedar St., New York.

CAUTION.—Purchasers and consumers are cautioned against imitations of our METALLIC PAINT. All genuine **PRINCE'S METALLIC PAINT** will bear our name and trade mark on each and every package. Send for a circular.

GREAT DEDUCTION. TEAS and COFFEES

At Wholesale Prices. Increased Facilities to Club Organizers. Send for New Price-List. THE GREAT AMERICAN TEA COMPANY, (P. O. Box 5643.) 31 and 33 Vesey St., New York.

WOOD, TABER & MORSE, Eaton, Madison Co., N. Y.

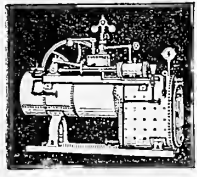

Steam-Engines, Portable, Stationary, and Agricultural.

Hundreds in use in Shops, Printing Rooms, Mills, Mines, and on Farms and Plantations for Grain Threshing, Food Cooking for Stock, Cotton Ginning, Sawing, etc. Circulars sent on application.

BOGARDUS' PATENT UNIVERSAL ECCENTRIC MILLS, For Grinding Bones, Ores, Fire Clay, Guanos, Oil-Cake, Feed, Corn, Cob, Tobacco, Roots, Salts, Spices, Flax-Seed, Tomatoes, &c., and whatever can not be ground by other Mills. Also, for Paints, Inks, Blacking, &c. JOHN W. THOMSON, Successor to James Bogardus, Corner of White and Elm Streets, New York.

BRICK MACHINERY, TILE MACHINERY, and SAW MILLS.

For sale by R. H. ALLEN & CO., 189 and 191 Water Street, P. O. Box 376, NEW YORK.

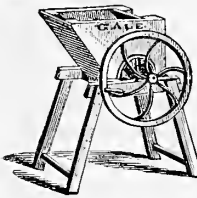

I have invented a Turnip and Carrot Cutter, that is lower in price, more simple, durable, and does the work more rapid and easy than any other in America. Don't pay till you have tried them on your farms and know what I say is true. Splendid chance for farmers and local agents. Circulars free.

WARREN GALE, Chicopee Falls, Mass.

Established in 1813.

R. H. ALLEN & CO.

Agricultural Implements, Machines, Seeds and Fertilizers, 189 and 191 Water Street, or P. O. Box 376, NEW YORK CITY.

F. G. MOELLER, Landscape Gardener and Engineer of Rural Improvements. Best of reference given. Address F. G. MOELLER, 176 Broadway (Room 58), N. Y.

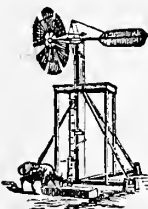

Halladay's Improved Wind-Mill.

PERFECTLY Self-Regulating. The Best, Cheapest, most Durable and Popular Mill made. Manufactured under the immediate supervision of inventor 18 years. Two million dollars' worth now in use. Send for Catalogue.

U. S. WIND ENGINE & PUMP CO., BATAVIA, ILL.

The New P. T. Barnum Coupon Hat. It will pay you to ask your hatter for it. Made by J. S. FAYERWEATHER & CO., Danbury, Conn. Send for descriptive circular.

BOOK AGENTS WANTED TELL IT ALL

to sell the New Book TELL IT ALL By Mrs. Stenhouse of Salt Lake City, for 25 years the wife of a Mormon High Priest. Introduction by Mrs. Stowe. This story of a woman's experience lays bare the "Hidden Life," mysteries, secret doings, etc. of the Mormons as a "wide-awake woman sees them." Bright, Pure and Good, it is the best new book out, actually overflowing with good things for all. It is popular everywhere, with everybody, and outsells all other books three to one. Ministers say "God speed it." Eminent women endorse it. Every body wants it; and agents are selling from 10 to 20 a day! 25th thousand now in press! We want 5000 more trustworthy agents NOW men or women—and we will mail Outfit Free to those who will canvass. Large pamphlets with full particulars, extra terms, etc. sent free to anyone. Address A. D. WORKINGTON & Co., Hartford, Conn.

GOOD NEWS for book agents, and others desiring employment. New books by popular authors.

LITTLE FOLKS IN FEATHERS AND CUR by OLIVE THORNE, and THE WAYS OF WOMEN, by Dr. J. V. C. SMITH. Splendidly gotten up. Beautifully illustrated. Nothing equal to them now offered to agents. THE LIFE AND ADVENTURES OF KIT CARSON is still selling rapidly. Over 20,000 already sold. \$50 a week easily made. STOWE'S SELF-INTERPRETING FAMILY BIBLE, the finest in the world. Circulars giving full and complete information sent free. Mention the books wanted. Address, DUSTIN, GILMAN & CO., Hartford, Conn.

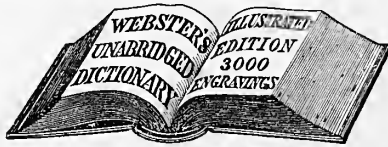

GET THE BEST.

Webster's Unabridged Dictionary.

10,000 Words and Meanings not in other Dictionaries. 3000 Engravings; 1840 Pages Quarto. Price \$12. Webster is now glorious. [Pres. Raymond, Vassar Col. very scholar knows its value. [W. H. Prescott. [Horace Mann. est defining Dictionary. [A. H. Clapp, Gov't Printer. standard in this office. [John G. Saxe. he etymology without a rival. [Pres. Hitchcock. xceeds in defining scientific terms. [Pres. Hitchcock. emarkable compendium of knowledge. [Pres. Clark. "THE BEST PRACTICAL ENGLISH DICTIONARY EXTANT."—London Quarterly Review, October, 1873. Published by G. & C. MERRIAM, Springfield, Mass. Sold by all Book-sellers.

THE FRUIT RECORDER AND COTTAGE GARDENER

will be sent FREE for 3 months of this year to all who will pay postage at office of delivery. We do not ask any one to subscribe for our paper until they know what they are to get. It speaks for itself. Price only \$1 per year. The Small Fruit Instructor is a work of 61 pp. that tells in simple language just how to grow fruits in abundance for home use or market. Price 25 cts., post-paid. A. M. PURDY, Putnam, N. Y.

Scribner's Lumber & Log-Book.

OVER HALF A MILLION COPIES SOLD. This is the most complete book of its kind ever published. It gives correct measurement of all kinds of lumber, logs, plank, cubical contents of square and round timber, stave and heading bolt tables, wages, rent, board, capacity of cisterns, cord-wood tables, interest, etc., and has become the Standard Book throughout the United States and Canada. Be sure and get the New Edition, with Doyle's Log-Table. Ask your bookseller for it, or I will send one for 25 cents, post-paid. G. W. FISHER, P. O. Box 238, Rochester, N. Y.

Self-Propel-For Cripples

Can be easily in or out doors, using the use of State your weight for illustrated ferent styles and Please mention this paper.



ling Chairs and Invalids

propelled, either by any one hand, and send stamp catalogue of diffrices. S. A. SMITH, No. 32 Platt St., N. Y. City.

LIVINGSTONE IS DEAD.

For 30 years millions have INTENTLY watched the PERILOUS STRUGGLES and GRAND ACHIEVEMENTS of this WORLD RENOWNED Hero, and now EAGERLY desire the Complete Life History which unfolds also the WEALTH and CURIOSITIES of a WILD and WONDERFUL COUNTRY. It is NOW READY and SELLING to heat everything. MORE AGENTS WANTED AT ONCE. For Particulars of this, our superb NEW Illustrated BIBLE, and OCEAN'S STORY, address HUBBARD BROS., Publishers, Philadelphia, Boston, or Cincinnati.

\$2500 A YEAR made with our grand COMBINATION PROSPECTUS.

Represents 50 different books. Agents say this is the BEST THING EVER TRIED. The Books sell themselves in every family, and good men can make a business for life in one county. Agents Wanted on these and our magnificent Editions of Family Bibles. Full particulars free on application. Address JOHN E. POTTER & CO., Publishers, Philadelphia.

FANCIER'S JOURNAL A Weekly devoted to Fowls, Pigeons, Rabbits, Dogs, Song Birds, etc. Send stamp for Specimen Copy. JOS. M. WADE, Philadelphia, Pa.

AGENTS WANTED FOR THE CENTENNIAL

GAZETTEER OF THE UNITED STATES. Showing the gigantic results of the "First 100 Years of the Republic." Agents make \$100 to \$500 per month. Send for circular. ZIEGLER & M'CURDY, Philadelphia, Pa.; Springfield, Mass.

TO BOOK AGENTS.

We offer special and extra commissions to agents this fall. Our new books are just ready, and will stir up the reading public. We shall announce them soon. Full information sent on application, and exclusive territory given. No agent, old or new, should make arrangement for books without first negotiating with us. We can and will give agents better books, better terms, and enable them to make more money than any other house.

Wanted—5,000 men and women as local agents, and 4 experienced men and 2 women to act as General and Traveling Agents in the North and South. For information of books and agencies address AMERICAN PUBLISHING CO., Hartford, Conn.

Four New Books!

(FOR AGENTS.)

OUR FIRST HUNDRED YEARS—12 monthly parts, 50 cts. each—2 parts now published. Life and Public Services of Charles Sumner. 5th Edition. Revised and Enlarged. Spirit of the Holy Bible.—Illustrated by the Old Masters. 600 Illustrations. Text in English, French, and German. Maria Monk's Daughter.—An Autobiography. Send for terms, specimen pages, and inducements. UNITED STATES PUBLISHING COMPANY, 13 University Place, New York.

The Young Housekeeper's Friend, by Mrs. Cornelius. The best Cook Book and guide for the various duties of the household published. Price \$1.50. Interleaved \$2.25. Sent by mail on receipt of price. THOMPSON BROWN & CO., Boston, Mass., Publishers.

Kimball's New Method for Reed Organ.

The latest, largest, and by far the best and most complete Instruction book for Reed Organs. Used exclusively by the best teachers. Contains complete instructions and a large amount of beautiful Reed organ music. Kimball's New Method contains 108 large, quarto pages, and is sold by all music dealers, or a copy will be mailed, post-paid, on receipt of \$2.50, by the publishers S. BRAINARD'S SONS, Cleveland, Ohio.

Every FARMER and STOCK RAISER, and EVERYBODY that keeps a HORSE, a COW, POULTRY, SHEEP or SWINE—whether he lives in CITY, TOWN, or COUNTRY, wants the

Live Stock Journal.

Monthly, \$1.50 per year. In its 5th Volume. Beautifully illustrated. The best instructor upon every class of Live Stock. National—giving equal attention to the Stock Interest of every State. Treats, by practical writers, upon the Farm, the Dairy, Horses, Cattle, Sheep, Swine, Poultry, Bees, Fish and their diseases. Specimen copy, 10 cents. Address LIVE STOCK JOURNAL CO., Buffalo, N. Y. Good pay to agents. Agents wanted at every post-office.

FANCIER'S JOURNAL A Weekly devoted to Fowls, Pigeons, Rabbits, Dogs, Song Birds, etc. Send stamp for Specimen Copy. JOS. M. WADE, Philadelphia, Pa.

CLAVELACK College and Hudson River Inst., at Clavelack, N. Y. Opens Sept. 7. ALONZO FLACK, Ph. D., Pres.

WRITES 10 HOURS THE HOLDER CONTAINS THE INK 350 & 400 HAWKES' PATENT HOLDER SAVES 10 TIMES FITS ANY PEN. 25 TO 30 BY MAIL SEND STAMP FOR CIRCULAR. 60 NASSAU ST. N. Y.

Samples from B. E. Hale & Co., 55 and 58 Park Place, N. Y. Sole Agents for Eastern States.

BUILDING PAPER! FOR SHEATHING, ROOFING, DEAFENING, CARPET LINING, AND PLASTERING!

Samples from Rock River Paper Company, Chicago, Ill.

WANTED.—The United States Life Insurance Company is now re-organizing its Agency Department, and is prepared to negotiate with gentlemen of business ability to act as Agents. Previous connection with the business is not considered necessary. Apply at the Home Office, 261 Broadway, New York. JOHN E. DEWITT, President.

SUPERIOR STANDARD WORKS.

Published by ORANGE JUDD COMPANY.

THE HORSE.

FRANK FORESTER'S HORSE OF AMERICA.



By HENRY WM. HERBERT.

Revised, corrected, enlarged, and continued to 1871, By S. D. and B. G. BRUCE.

Always an ACKNOWLEDGED STANDARD, and now the most COMPLETE and AUTHENTIC Work on the HORSE. With steel-engraved portraits of Thirty of the most famous

REPRESENTATIVE HORSES,

including pedigrees, histories, and performances. Two superb royal octavo volumes of upward of 1300 pages.

Post-Paid, Ten Dollars.



WALLACE'S

American Trotting Register.

CONTAINING ALL THAT IS KNOWN OF THE

PEDIGREES OF TROTTING HORSES

their ancestors and descendants, with a record of

All published performances in which a mile was trotted or paced in 2.40 or less,

from the earliest dates until the close of 1868, and a full record of the performances of 1869 and 1870.

Giving complete Summaries of over 6,000 Contests.

With an INTRODUCTORY ESSAY on the true origin of the American Trotter. And a set of Rules for the government of all trials of speed. By J. H. WALLACE, compiler of Wallace's American Stud-Book. Royal octavo.

Post-paid, Ten Dollars.

WALLACE'S AMERICAN STUD-BOOK.

VOL. ONE.—BEING A COMPILATION OF THE

PEDIGREES OF AMERICAN AND IMPORTED BLOOD HORSES,

from the earliest records, with an APPENDIX of all named animals without extended Pedigrees prior to the year 1840. And a SUPPLEMENT, containing a history of all Horses and Mares that have trotted in public from the earliest trotting races until the close of 1866. By J. H. WALLACE. Royal octavo of over 1,000 pages elegantly bound in extra cloth, beveled boards, and splendidly illustrated.

Post-paid, Ten Dollars.

Horse Portraiture. — BREEDING,

REARING, AND TRAINING TROTTERS. Preparations for Races, Management in the Stable, on the Track, Horse Life, etc. By JOSEPH CAIRN SIMPSON. Post octavo. Post-paid, \$3.00.

FIELD SPORTS.

Frank Forester's Field Sports.

Embracing the Game of North America, Upland Shooting, Bay Shooting, Wild Sporting of the Wilderness, Forest, Prairie, and Mountain Sports, Bear Hunting, Turkey Shooting, etc. 13th edition, revised and illustrated. Two post octavo volumes. Post-paid, \$6.00.

Frank Forester's Fish and Fishing.

100 engravings. Embracing a full illustrated description of the Game Fish of North America; Trout and Salmon Fishing; Shoal Water and Deep Sea Fishing; Lake and River Fishing; Trolling; Fly Fishing, etc. 12th edition. One post octavo volume. Post-paid, \$3.50.

Frank Forester's Complete Manual.

For Young Sportsmen, of Fowling, Fishing, an Field Sports. With directions for handling the Gun, the Rifle, and the Rod. Art of Shooting on the Wing. The Breaking, Management, and Hunting of the Dog. The varieties and habits of Game. River, Lake, and Sea Fishing. Post octavo. Post-paid, \$3.00.

Frank Forester's American Game in its SEASONS, Fully Illustrated and Described. New edition, post-paid, \$3.00.

The Dog.

By Dinks, Mayhew & Hutchinson. Compiled and edited by Frank Forester. Containing full instructions in all that relates to the Breeding, Rearing, Breaking, Kenneling, and Conditioning of Dogs, with valuable recipes for the treatment of all diseases. Illustrated. Post octavo. Post-paid, \$3.00.

The Dead Shot:

Or, Sportsman's Complete Guide; a Treatise on the use of the Gun, with Rudimentary and Finishing Lessons in the Art of Shooting Game of all kinds. By Marksman. Post-paid, \$1.75.

The Crack Shot:

Or, Young Rifleman's Complete Guide; being a Treatise on the use of the Rifle, with Lessons, including a full description of the latest improved breech-loading weapons; rules and regulations for Target Practice, and directions for Hunting Game. By Edward C. Barber. Post-paid, \$1.75.

Gun, Rod, and Saddle.

Nearly fifty practical articles on subjects connected with Fishing, Shooting, Racing, Trotting, etc. Post-paid, \$1.

ORANGE JUDD COMPANY, 245 Broadway, N. Y.

BOOKS FOR FARMERS AND OTHERS.

[Published and for sale by the Orange Judd Company, 245 Broadway, New York. Any of these books will be forwarded by mail, post-paid, on receipt of price.]

Allen's (L. F.) American Cattle.....	\$ 2 50
Allen's (L. F.) Rural Architecture.....	1 50
Allen's (R. L.) American Farm Book.....	1 50
Allen's (R. L. and L. F.) New American Farm Book.....	2 50
Allen's (R. L.) Diseases of Domestic Animals.....	1 00
American Bird Fancier.....	30
American Rose Culturist.....	30
American Weeds and Useful Plants.....	1 25
Atwood's Country and Suburban Homes.....	1 50
Barry's Fruit Garden.....	2 50
Bennett's Rabbit Fancier.....	30
Bonmer's Method of Making Manures.....	25
Boussingault's Rural Economy.....	1 60
Breech-Loader.....	2 00
Burns' New Book of Flowers.....	1 25
Brill's Farm-Gardening and Seed-Growing.....	1 00
Bryant's Forest-Tree Culturist.....	1 50
Buist's Flower Garden Directory.....	1 50
Buist's Family Kitchen Gardener.....	1 00
Caldwell's Agricultural Chemical Analysis.....	2 00
Chorlton's Grape-Grower's Guide.....	75
Colbitt's American Gardener.....	75
Cole's (S. W.) American Fruit Book.....	75
Cole's Veterinarian.....	75
Copley's Plain and Ornamental Alphabets.....	3 00
Crack Shot. (Barber.).....	1 75
Cummings' Architectural Details.....	10 00
Dadd's (Geo. H.) Modern Horse Doctor.....	1 50
Dadd's American Cattle Doctor.....	1 50
Dana's Muck Manual.....	1 25
Darwin's Variation of Animals and Plants. 2 Volumes.....	6 00
Dead Shot, or Sportsman's Complete Guide.....	2 00
De Voe's Market Assistant.....	2 50
Downing's Fruits & Fruit Trees, New Ed. Oct., 112 pp.....	5 00
Downing's Landscape Gardening.....	6 50
Eastwood on Cranberry.....	75
Eggleston's Hooster School-Master.....	1 25
Eggleston's End of the World.....	1 50
Eggleston's Mystery of Metropolisville.....	1 50
Eggleston's (Geo. Garry) A Man of Honor.....	1 25
Elliot's Western Fruit Grower's Guide.....	1 50
Eveloth's School House Architecture.....	6 00
Every Woman her own Flower-Gardener, pa., 50c. clo.....	1 00
Field's (Thomas W.) Pear Culture.....	1 25
Flax Culture.....	50
Frank Forester's American Game in its Season.....	3 00
Frank Forester's Field Sports, 8vo, 2 vols.....	6 30
Frank Forester's Fish and Fishing, 8vo, 100 eng's.....	3 50
Frank Forester's Manual for Young Sportsmen, 8vo.....	3 00
Frank Forester's Horse of America, 8vo, 2 vols.....	10 00
French's Farm Drainage.....	1 50
Fuller's Forest Tree Culturist.....	1 50
Fuller's Grape Culturist.....	1 50
Fuller's Small Fruit Culturist.....	1 50
Fuller's Strawberry Culturist.....	20
Fulton's Peach Culture.....	1 50
Gregory on Squashes..... paper.....	30
Greenall on Milch Cows.....	75
Gun, Rod, and Saddle.....	1 00
Harvey's Barns, Out-buildings, and Fences.....	6 00
Harris' Insects Injurious to Vegetation, clo, \$4; col. pls.....	6 50
Harris on the Pig.....	1 50
Henderson's Gardening for Profit.....	1 50
Henderson's Practical Floriculture.....	1 50
Herbert's Hints to Horsekeepers.....	1 75
Hoopes' Book of Evergreens.....	3 00
Hoopes' Dog and Gun..... paper, 30c. cloth.....	60

Hop Culture.....	\$ 40
Hunter and Bowman.....	1 00
Hussey's National Cottage Architecture.....	6 00
Jacques' Manual of the House.....	1 50
Jacques' Manual of the Garden and Farm-Yard.....	1 75
John Andross. (Rebecca Harding Davis).....	1 50
Johnson's How Crops Feed.....	2 00
Johnson's How Crops Grow.....	2 00
Johnson's Peat and Its Uses.....	1 25
Johnson's Agricultural Chemistry.....	1 25
Johnson's Agricultural Chemistry.....	1 50
Leuchiar's How to Build Ho-Houses.....	1 50
Lyman's Cotton Culture.....	1 50
Miles on the Horse's Foot.....	75
Mohr on the Grape-Vine.....	1 00
Monckton's National Carpenter and Joiner.....	6 00
Monckton's National Stair-Builder.....	6 00
Mrs. Cornelius's Young Housekeeper's Friend.....	1 25
My Vineyard at Lakeview.....	1 25
Norton's Scientific Agriculture.....	75
Onion Culture.....	20
Our Farm of Four Acres..... paper, 30c. cloth.....	60
Pardee on Strawberry Culture.....	75
Parsons on the Rose. By Samuel B. Parsons.....	1 50
Pedder's Land Measurer.....	60
Percheron Horse.....	1 00
Potato Culture. (Prize Essay)..... paper.....	1 50
Pretty Mrs. Cotton. (J. Esten).....	1 50
Quincy's Mysteries of Bee Keeping.....	1 50
Quinn's Money in the Garden.....	1 50
Quinn's Pear Culture for Profit.....	1 00
Randall's Sheep Husbandry.....	1 50
Randall's Fine Wool Sheep Husbandry.....	1 00
Richardson on the Dog..... paper, 30c. cloth.....	60
Rivers' Miniature Fruit Garden.....	1 00
Ro's Play and Frolic in my Garden.....	1 50
Standard Domestic Poultry..... paper, 40c. bound.....	75
Schenck's Gardener's Text-Book.....	3 00
Simpson's Horse Portraiture.....	75
Skillful Housewife.....	75
Slack's Trout Culture.....	1 50
Stewart's (John) Stable Book.....	1 50
The Dog. By Dinks, Mayhew, and Hutchinson.....	3 00
Thomas' Farm Implements and Machinery.....	1 50
Thompson's Food of Animals.....	1 00
Tim Basset Papers.....	1 50
Tobacco Culture.....	25
Turner's Cotton Planter's Manual.....	1 50
Wallace's American Trotting Register, Vol. 1.....	10 00
Wallace's American Stud Book, Vol. 1.....	10 00
Warder's American Pomology.....	3 00
Warder's Hedges and Evergreens.....	1 50
Waring's Draining for Profit and Health.....	1 50
Waring's Elements of Agriculture.....	1 00
Waring's Earth Closets and Earth Sewage.....	50
Weidenmann's Beautifying Country Homes, A superb quarto volume, 24 lithograph plates, in colors.....	15 00
Wheeler's Rural Homes.....	2 00
Wheeler's Homes for the People.....	3 00
White's Cranberry Culture.....	1 25
White's Gardening for the South.....	2 00
Window Gardening.....	1 50
Woodward's Cottages and Farm-Houses.....	1 50
Woodward's Suburban and Country Houses.....	1 50
Woodward's Country Homes.....	1 50
Woodward's Graperies and Horticultural Buildings.....	1 50
Woodward's National Architect.....	12 00
Wright's Illustrated Poultry Book.....	15 00
Wright's Practical Poultry Keeper.....	2 00
Youatt and Spooner on the Horse.....	1 50
Youatt and Martin on Cattle.....	1 50
Youatt on the Dog.....	1 00
Youatt on Sheep.....	1 00

O. J. Co. keep in Stock the following Books:

Architecture. By Cummings & Miller.....	\$10 00
Architecture. Modern American. By C. & M.....	10 00
" Bicknell's Village Builder.....	10 00
" Supplement to Village Builder.....	5 00
" Village Builder and Supplement, 1 Vol.....	12 00
" Detail, Cottage and Constructive.....	10 00
Art of Saw Filing. (Holly).....	75
Bailey's Our Own Birds of the United States.....	1 50
Bement's Poultryer's Companion.....	2 00
Brigman's Veterinary and Gardener's Assistant.....	1 50
Burns' Architecture as Drawing Book.....	1 00
Burns' Illustrated Drawing Book.....	1 00
Burns' Ornamental Drawing Book.....	1 00
Burr's Vegetables of America.....	5 00
Carpenters and Builders' Guide.....	1 00
Carpenters and Joiners' Hand-Book. (Holly).....	75
Carpenter and Joiner. (R. Riddell).....	10 00
Chemistry of the Farm. (Nichols).....	1 25
Older-Maker's Manual.....	2 00
Downing's Rural Essays.....	5 00
Du Brenil's Vineyard Culture. (Dr. Warder).....	2 00
Farming for Boys.....	1 50
Fishing in American Waters. (Scott).....	3 50
Flint (Charles L.) on Grasses.....	2 50
Flint's Milch Cows and Dairy Farming.....	2 50
Geyelin's Poultry Breeding.....	1 25
Gray's How Plants Grow.....	1 25
Gray's 400 Flowers in one vol.....	2 50
Gray's School and Field Book of Botany.....	2 50
Harazthy's Grape Culture and Wine-Making.....	5 00
Hatfield's American House Carpenter.....	3 50
Horse Training Made Easy. (Jennings).....	1 25
Husmann's Grapes and Wine.....	1 50
Jennings on Cattle.....	1 75
Jennings on Sheep, Swine, and Poultry.....	1 75
Jennings on the Horse and his Diseases.....	1 75
Ken's Land and Garden.....	2 50
Langstroth on the Honey Bee.....	2 00
Loth's Stair Builder.....	10 00
Mayhew's Illustrated Horse Doctor.....	3 00
Mayhew's Illustrated Horse Management.....	3 00
Mayhew's Practical Book-Keeping for Farmers.....	90
Blanks for do do do.....	1 20
Mechanic's Companion. (Nicholson).....	3 00
Norrill's American Shepherd.....	1 75
My Farm of Yellowood.....	2 25
Norris' Fish Culture.....	1 75
Packard's A Guide to the Study of Insects.....	6 00
Painter, Gilder, and Varnisher.....	1 50
Quincy (Hon. Josiah) on Solling Cattle.....	1 25
Randall's Practical Shepherd.....	2 00
Rand's Bulbs.....	1 50
Rand's Flowers for Parlor and Garden.....	3 00
Register of Rural Affairs. Bound, 6 vols., each.....	1 50
Riddell's New Elements of Hand Railing.....	7 00
Rosevelt's Five Acres too Much.....	1 50
Rural Studies.....	1 75
Scribner's Ready Reckoner and Log-Book.....	30
Silloway's Modern Carpentry.....	2 00
Stonehenge on the Dog.....	3 75
Strong's Cultivation of the Grape.....	3 00
Tegetmeyer's Poultry Book.....	9 00
Ten Acres Enough.....	1 50
The Home. (Stonehenge.) Am. edition, 8vo.....	2 50
The Mule. (Riley).....	1 50
Thomas Fruit Culturist.....	3 00
Trapper's Guide.....	1 50
Tucker's Register of Rural Affairs.....	3 80
Vaux's Villas and Cottages.....	3 00
Watson's American Home Gardener.....	2 00
Willard's Practical Dairy Husbandry.....	3 00
Youmans' Household Science.....	2 00

RICH FARMING LANDS

For Sale VERY CHEAP by the

UNION PACIFIC RAILROAD COMPANY

MILLIONS OF ACRES

IN THE

STATE OF NEBRASKA

AT PRICES RANGING FROM

\$2 to \$10 per Acre.

**FIVE AND TEN YEARS CREDIT GIVEN,
With Interest at Six per Cent.**

Convenient to Markets East and West.

The Lands of the Union Pacific Railroad Company are the odd numbered Sections for twenty-miles on each side of the road. They are located in the valley of the Platte and its tributaries—a region widely celebrated for its beautiful scenery, rich productive soil, and mild and healthful climate. The winters are short, and the atmosphere dry and invigorating. Epidemic diseases are unknown. The surface is undulating, covered with nutritious grasses, and watered with numerous clear running streams. All the productions of the Eastern and Middle States are grown with success. Wheat and Corn are the staples, and it is well adapted to the cultivation of Fruit. For Stock-raising, in all its branches, these lands are unsurpassed. The Union Pacific and its branch railroads furnish market facilities unequalled. Education is free. One-eighteenth part of the entire area forms a permanent endowment of the Public Schools. Good Society, Schools, Churches, Post-Offices, Mills, Stores, and other advantages of civilization are enjoyed.

The liberal provisions made for Education, the freedom from State debt, the rapidity with which this section is settling, the numerous towns and villages springing up, offering inducements to the merchant, farmer, and mechanic, render this tract a most desirable location for the industrious man of limited means to secure a comfortable home, and acquire competence, independence, and position.

These lands are granted directly to the Railroad Company. The title given to the purchaser is absolute, in fee simple, free from incumbrances.

They are sold in tracts of forty acres and upwards, giving the man of small means an equal chance with the capitalist to make a safe and profitable investment, one which can not be destroyed by fire or flood, a provision for future support, not affected by *revulsions*, or liable to the fluctuations of stocks.

Full information in reference to particular localities will be furnished, good lands selected, and sales made, free of charge, for persons not desiring to incur the expense of coming to examine the lands in person.

ALSO

THE PIONEER,

A handsome ILLUSTRATED PAPER, with Maps, etc., and containing the HOMESTEAD LAW, mailed free to all applicants, by addressing

O. F. DAVIS,

Land Commissioner U. P. R. R. Co.,

Omaha, Neb.

GAS LIGHT FOR ALL.

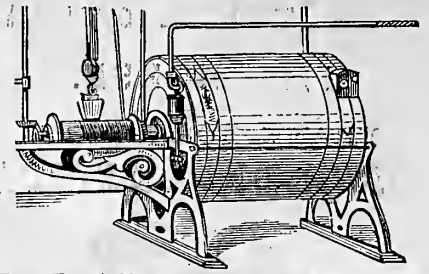

Every Household can be supplied with a beautiful illuminating Gas by

THE KEYSTONE SAFETY GAS MACHINE.

It is simple in construction, safe in operation, and certain in results. For Villages, Churches, Rural Homes, Institutions, etc., the Keystone apparatus affords the most perfect means of illumination yet discovered.

Pamphlets and full information on application.

The Keystone Safety Gas Machine Co.,

J. B. WILSON, Pres. C. H. BAKER, Sec.
717 Sanson St., Philadelphia.
1110 Liberty St., New York.

\$25 A DAY GUARANTEED using our WELL AUGER AND DRILL in good territory. HIGHEST TESTIMONIALS FROM GOVERNORS OF IOWA, ARKANSAS AND DAKOTA. Catalogues free. W. GILES, St. Louis, Mo.

CHICAGO & NORTH-WESTERN RY.

THE TRANS-CONTINENTAL ROUTE.

This is the Pioneer line between Chicago and the Pacific Coast, and was the first to connect with the great Pacific roads, and form the OVERLAND ROUTE. This line is the shortest rail line between Chicago and Omaha; the track is of the best steel rail, and is well ballasted, and as free from dust as a road can be made; the bridges are strong and durable; and all the appointments are first-class in every respect. The trains that run over this line are made up of elegant new Pullman Palace Drawing Room and Sleeping Coaches built expressly for this line, luxurious, well lighted and well ventilated Day Coaches, and pleasant lounging and smoking cars; all built by this Company in their own shops. The cars are all equipped with the celebrated Miller Safety Platform, and patent Buffers and Couplings, Westinghouse Safety Air Brakes, and every other appliance that has been devised for the safety of passenger trains. All trains are run by telegraph. In a word, this GREAT CALIFORNIA LINE has the best and smoothest track, and the most elegant and comfortable equipment of any road in the West; and has no superior in the country. It is eminently the favorite route with Chicagoans traveling west, and is acknowledged by the traveling public to be the popular line for all points in Western Iowa, Nebraska, Wyoming, Colorado, Utah, Montana, Idaho, Nevada, California, and the Pacific Slope.

All Coupon Ticket Agents sell tickets by this route. If you are going West, you should try this route.

NEW YORK OFFICE: No. 229 Broadway.
BOSTON OFFICE: No. 5 State Street.

CHICAGO TICKET OFFICES:

62 Clark Street, under Sherman House.
Corner Canal and Madison Streets.
Kinzie Street Depot, cor. West Kinzie and Canal Streets.
Wells Street Depot, corner Wells and Kinzie Streets.
MARVIN HUGHTT, W. H. STENNETT,
General Superintendent. General Passenger Agent.

FIRE PROTECTION For Cities & Towns.

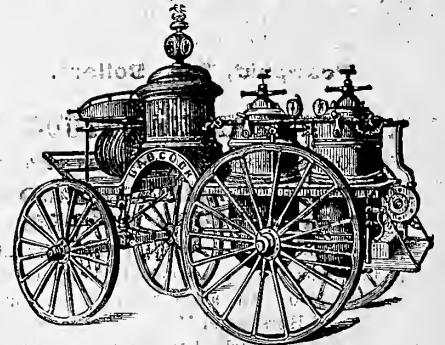

BABCOCK

SELF-ACTING FIRE ENGINE.

Adopted by New York, Boston, Chicago, Cincinnati, and One Hundred other Cities.

THE BABCOCK MANUFACTURING COMPANY,

407 Broadway, New York.
317 to 331 South Desplaines St., Chicago.

DECEMBER, 1874.

AMERICAN

AGRICULTURIST

FOR THE FARM, GARDEN & HOUSEHOLD.

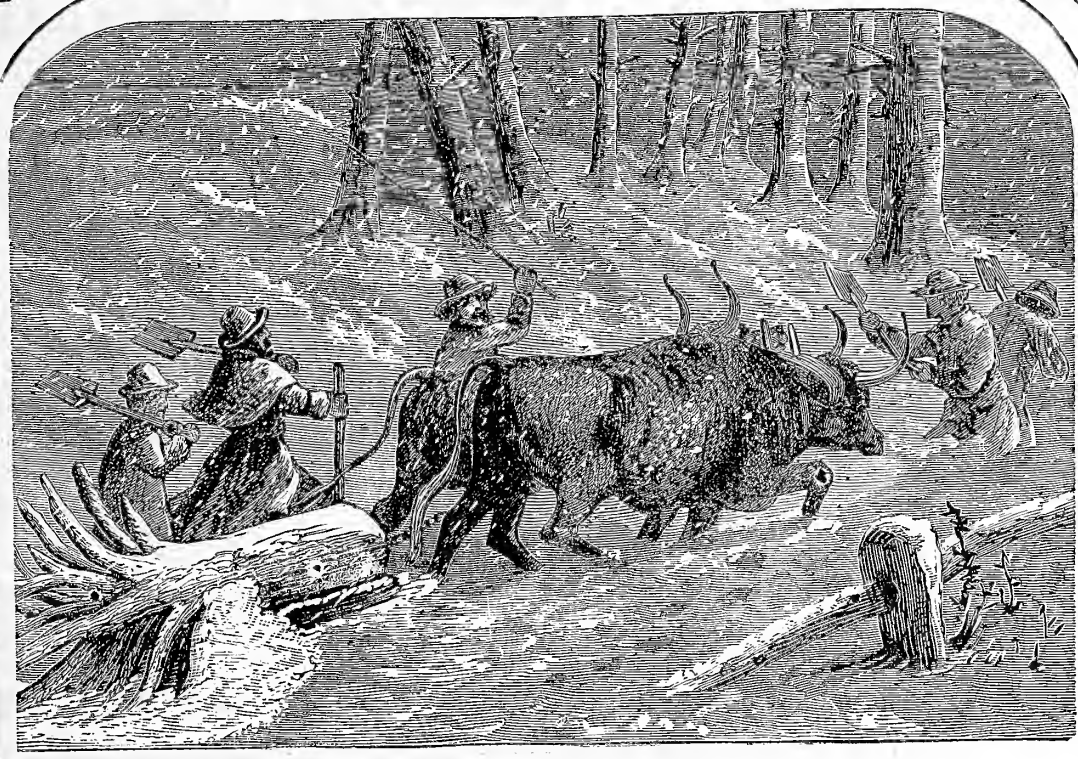

Vol. XXXIII

Number 12



PUBLISHED BY THE
ORANGE JUDD COMPANY,
245 BROADWAY,
NEW-YORK.

THE REMINGTON WORKS, ILION, N. Y.

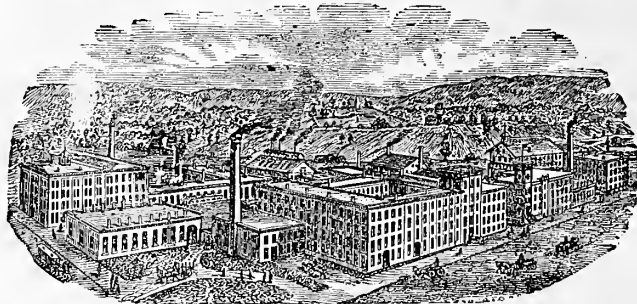

REMINGTON

Sewing Machines, Fire Arms, Agricultural Implements.

The REMINGTON SEWING MACHINE has sprung rapidly into favor, as possessing the best COMBINATION of good qualities, namely: Light running, smooth, noiseless, rapid, durable, with perfect Lock Stitch.

It is a Shuttle Machine, with Automatic Drop Feed. Design beautiful and construction the very best.

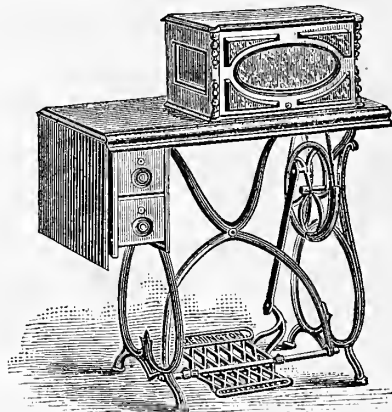

REMINGTON No. 1 Machine for family use, in the *third year of its existence*, has met with a more rapid increase of ratio of sales than any machine on the market.

REMINGTON No. 2 Machine for manufacturing and family use, (ready for delivery only since June, 1874), for range, perfection, and variety of work, is without a rival in family or workshop.

AGRICULTURAL IMPLEMENTS.—Improved Mowing Machines, Steel Plows, Steel Hoes, Cultivators, Road Scrapers, Patent Excavators, Hay Tedders, Cotton Gins, Iron Bridges, ETC. **Good Agents Wanted. Send for Circulars.**



The REMINGTON WORKS also manufacture the new **Double-Barrelled Breach-Loading Shotgun**, snap and positive action, with *patent joint check*, a marvel of beauty, finish, and cheapness—and the **Celebrated Remington Rifles**—ADOPTED BY NINE DIFFERENT GOVERNMENTS—and renowned throughout the world for Military, Hunting, and Target purposes—ALL KINDS OF PISTOLS, Rifle Cases, METALLIC CARTRIDGES, ETC.

The score made by Lieut. Fulton at Creedmore Sept. 26th, 1874, with a Remington Rifle, was the highest ever made at any match, either in this country or in Europe.



BRANCH OFFICES OF REMINGTON COMPANIES.

**E. Remington & Sons,
Remington Sewing M. Co.,
Remington Ag'l Co.**

281 & 283 Broadway, New York, Arms.
Madison Square, New York, Sewing Machines.
Chicago, 237 State Street, Sewing Machines and Arms.
Boston, 333 Washington Street, Sewing Machines.
Cincinnati, 181 West 4th Street, Sewing Machines.
Utica, 129 Genesee Street, Sewing Machines.
Atlanta, Ga., De Give's Opera House, Marietta Street, Sewing Machines.
Washington, D. C., 521 Seventh Street, Sewing Machines.

THE MITCHELL WAGON.

THE
Best Proportioned,
Best Ironed,
AND
Lightest Running
Wagon in the Market.
The original, well known
RACINE WAGON.

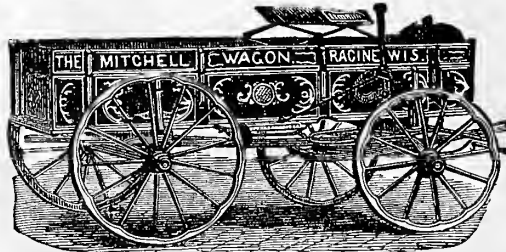

In use and for sale in nearly every
STATE & TERRITORY
IN THE UNION.
All work fully warranted.
SEND FOR PRICE LIST.
Mitchell, Lewis
& Co.,
RACINE, WIS.

BLAKE'S PATENT STONE AND ORE BREAKER.

New Patterns, with Important Improvements and Abundant Strength.

For reducing to fragments all kinds of hard and brittle substances, such as STONE for making the most perfect MCADAM PAVES, and for making the best CONCRETE. It breaks stone at trifling cost for BALLASTING RAILROADS. It is extensively in use in MINING operations, for crushing

IRON, COPPER, ZINC, SILVER, GOLD, and other ORES.
Also for crushing Quartz, Flint, Emery, Corundum, Feldspar, Coal, Barytes, Manganese, Phosphate Rock, Plaster, Soapstone, etc.
BLAKE CRUSHER CO., NEW HAVEN, CONN.

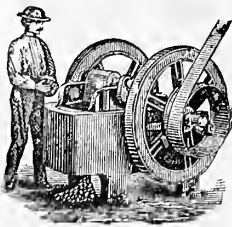

Oldest, Largest, Best.



EVERY FARMER OR BUSINESS MAN SHOULD HAVE A

Life or Accident Policy.

Apply to any agent, or write to the Company, at Hartford, Conn.

1776 1876

INTERNATIONAL EXHIBITION.

OFFICE OF THE U. S. CENTENNIAL COMMISSION, PHILADELPHIA, PA.

In accordance with the several Acts of the Congress of the United States, providing for the celebration of the

CENTENNIAL ANNIVERSARY

of American Independence, there will be held in FAIRMOUNT PARK, Philadelphia, in the year 1876, an

INTERNATIONAL EXHIBITION

of Arts, Manufactures, and Products of the Soil and Mine. The Exhibition will be opened on the 19th of April and closed on the 19th of October.

APPLICATIONS FOR SPACE.

To secure space for exhibits in the Buildings or the Park, early application should be made. The necessary forms for application, together with the Regulations for Exhibitors and needed information, will be forwarded on application to the Office of the Centennial Commission.

A. T. GOSHORN, Director-General.
J. L. CAMPBELL, Secretary.



Readily attached to any Stove. Introduced 8 Years. Thousands in Use. Once used, never dispensed with.

Agents Wanted at once in valuable Territory. Circulars on application. American Manufacturing Co., 102 Orange St., NEW HAVEN, Conn.

HOME CORN-SHELLER.

The best HAND SHELLER for family use in the market. Every machine warranted. Price \$2.50. Every Farmer and Poultry-raiser needs it. Agents wanted.

LIVINGSTON & CO., Iron Founders, Pittsburgh, Pa.



Wrought Iron Fencing of the Best English Make. Can be set up with ease—is an absolute protection against cattle—is ornamental, and practically indestructible. Is superior to every other form of enclosure. Send for illustrated circular. YARNALL & TRIMBLE, 147 S. Front St., Philadelphia.

INVENTORS

Who wish to secure PATENTS should write to MUNN & CO., 37 Park Row, New York, for Advice and Pamphlet, 103 pages, FREE.

ADVERTISING RATES.

American Agriculturist. ENGLISH EDITION.

Inside Pages, \$1.50 per line (agate), each insertion.
Open Pages (open without cutting), \$2 per line.
Last Page, and 2d and 3d Cover Pages—\$2.50 per line.
Page next to Reading and Last Cover Page—\$3.00 per line.
No advertisement taken for less than \$4.50 each insertion.

GERMAN EDITION.

Inside Pages, 25 cents per line, each insertion.
Business Notices and Last Page, 40 cents per line.
No advertisement taken for less than \$1.00 each insertion.

No Advertisement of Medicines or Humbugs received. Address all orders to

ORANGE JUDD COMPANY,
25 BROADWAY, NEW YORK.

AMERICAN AGRICULTURIST

FOR THE

Farm, Garden, and Household.

"AGRICULTURE IS THE MOST HEALTHFUL, MOST USEFUL, AND MOST NOBLE EMPLOYMENT OF MAN."—WASHINGTON.

ORANGE JUDD COMPANY,
PUBLISHERS AND PROPRIETORS.
Office, 245 BROADWAY.

ESTABLISHED IN 1842.

Published also in German at same rates as in English.

TERMS: \$1.50 PER ANNUM IN ADVANCE;
4 Copies for \$5; 10 for \$12; 20 or more, \$1 each;
10 Cents additional must be sent with each Sub-
scription for postage.—Single Number, 15 Cents.

Entered according to Act of Congress, in November, 1874, by the ORANGE JUDD COMPANY, at the Office of the Librarian of Congress, at Washington.

VOLUME XXXIII.—No. 12.

NEW YORK, DECEMBER, 1874.

NEW SERIES—No. 335.

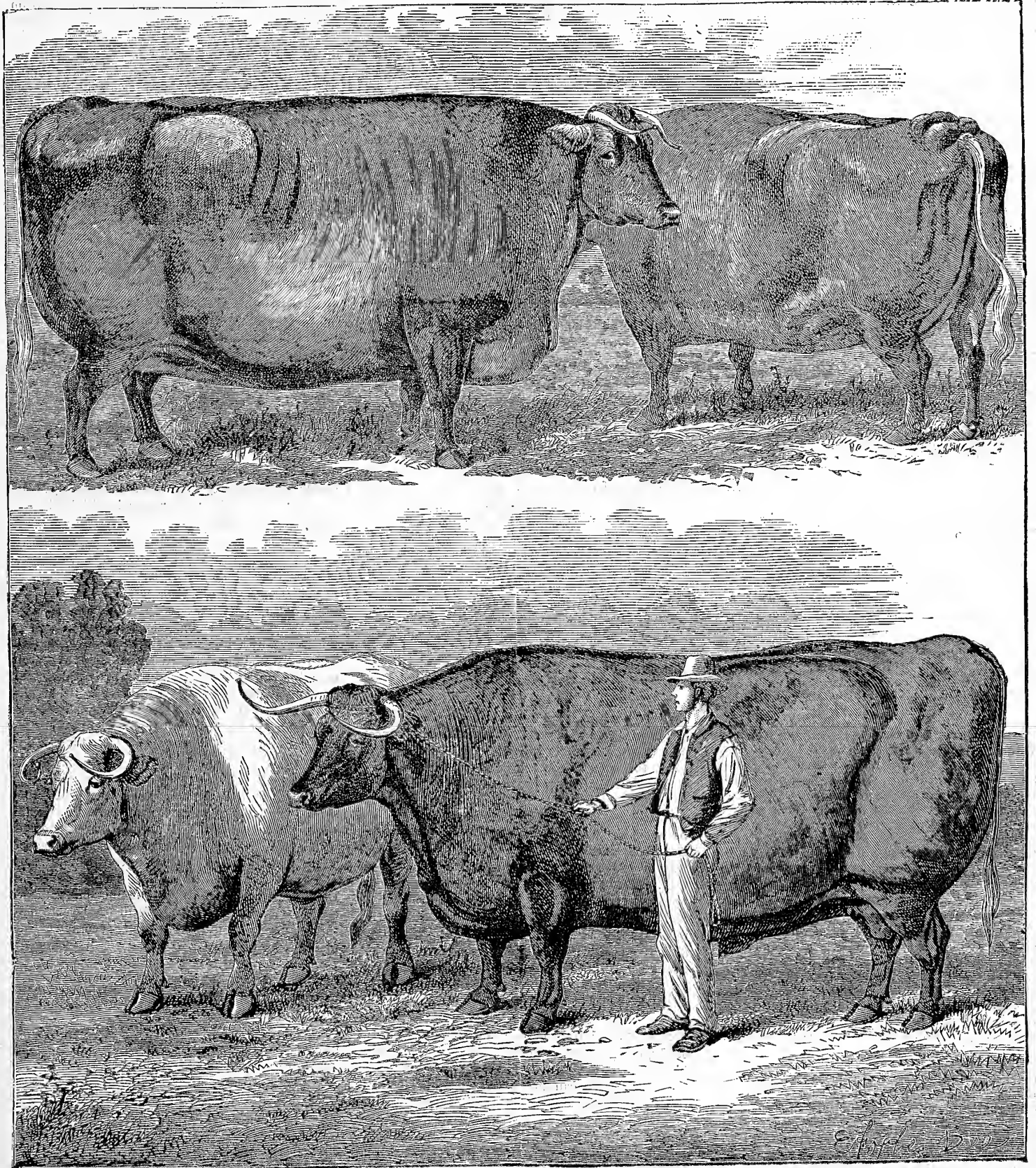

HEAVY SHORTHORN GRADE CATTLE. — (See page 449.)—Drawn and Engraved for the American Agriculturist.

Contents for December 1874.

Beef from Colorado... 453
Bee Notes... 448
Boys and Girls' Columns... 442
Aunt Sue's Puzzle-Box... 465, 466
Cattle, Heavy Shorthorn Grade... 449
Cucumber, Russian Netted... 462
Dogs, Legislation in Reference to... 457
Farm Tools, Hungarian... 454
Farm Work for December... 442
Feed Box, Self-supplying... 454
Ferns, Moonwort... 461
Flower Garden and Lawn in December... 444
Flowers, Preserving... 460
Fruit Garden in December... 443
Grapes, More New... 460
Grapes, Mr. Ricketts' Hybrid... 461
Greenhouse and Window Plants in December... 444
Horse Clothing... 454
Horticulture at the International Exhibition... 458
Hound, Badger... 451
Household Department... 443
Orchard and Nursery in December... 443
Pansy, New White... 459
Pea, Everlasting... 459
Plants Received by Mail... 459
Plants, Unhealthy... 460
Rail, Yellow-Breasted... 451
Rustle Poreh... 462
Stock Sales, Foreign... 457
Wagon Spring, an Easy... 450
Walks and Talks on the Farm... 443
Cooking Food for Stock... 453
Fall Work—Manure... 453
Weed in California... 450

Calendar for December.

Table with columns for Day of Month, Day of Week, and sunrise/sunset times for Boston, N. York, Philadelphia, and Washington.

PHASES OF THE MOON.

Table showing moon phases (New Moon, 1st Quart, Full Moon, 3d Quart) for Boston, N. York, Wash'n, Cha'ston, and Chicago.

AMERICAN AGRICULTURIST.

NEW YORK, DECEMBER, 1874.

With this number close both the volume and the year. December is especially a month for retrospection. As the days shorten, we return in mind to those longer and busier days which have passed. The farmer lives greatly in the future. His life is one of anticipation. He sows his seed and waits patiently for the harvest. He "learns to labor and to wait." But now that his land, with what crop it may be bearing, rests for a season, he naturally looks back over the closing year. There is profit in it if he does this wisely. We love to remember our victories, but it is more profitable to remember our mistakes and defeats. Even those of the greatest knowledge and experience are ever making mistakes. To wisely consider the mistakes of the year gone by, their causes and results, will help us to avoid similar errors in the future. Many a farmer now sees where his short crop, cut down by drouth, ravaged by insects, overpowered by weeds, might have been made a full one. This has been a year of disaster in portions of the west, and ruin—if a true man can ever be ruined—has come to some. Here too is matter for consideration. How shall the ravages of insects be repressed or mitigated? For no intelligent man is content to succumb to disaster, and to say it can not be avoided. There is a cure for every evil, and doubtless, many who have suffered have seen a way by which they may help themselves in the future. But, as a whole, the agricultural interest has no cause for complaint. If prices are low there is more to sell, and low prices tend to stimulate better methods of production. What we need more than anything else is not so much great crops, as crops cheaply raised. Cheapness of production is equivalent to a high selling price. It does not matter at which end the gain is made, so that a gain results. Cheap food is a great stimulus to general prosperity, and if by close observation or careful study, the farmer can profitably reduce the cost of his crops, the whole industry of the country is benefited. We can not avoid competition with other countries where laborers work for a bare subsistence, but we can by the use of machinery and improved processes, make one of our laborers do the work of three, live well, and lay up something towards buying a farm of his own. In looking over

our agricultural products, we must not forget to consider what kind of men we are raising, and when we look upon the general condition of the agricultural community, and find that the large farmer has not made large profits, it will be well to remember that every man in his employ is well housed, well clothed, and well fed; that his children go to school, and have any career open to them that they are fitted for, and that the man himself reads the papers, chooses his "rulers," and is looking for the not far-off time, when he himself shall be a land-owner. There is no reason for despondency, and the year closes upon a generally prosperous and always improving people.

Hints about Work.

Farm machinery now represents a large portion of the farmer's capital. Next to his land and live stock, his machinery costs the most money. Frequently it costs more than the live stock. It ought to be carefully used and kept. Whatever implement has not been thoroughly cleaned, oiled, and put away, should now be attended to. Machinery will be used more and more, and a man of intelligence can use it most profitably. Farmers should therefore study mechanics, not only that they may know how to use and care for their machines, but how to improve them and invent new ones. Many new agricultural machines are brought out, that are useless from the first, because the inventors knew nothing about agriculture. An inventor of a new plowing machine, acknowledged to us that he did not know that sod should be turned over when plowed. He had a machine that tore it into fragments and left it upon the surface. Farmers should be their own inventors, and in course of time they will be, if the young men study.

The Stables.—If our earlier hints have been regarded, the stables will now only need daily cleaning. Manure should not be left to freeze in hard lumps beneath the stock. The stables should be warm enough to prevent freezing in them, or the cattle will suffer loss, or more feed must be given. By wheeling out the manure the first thing each morning to the heap in the yard, and piling it up neatly and compactly, the whole may be kept from freezing during the winter, and it will be in fine condition for use in the spring.

Cellars.—Root cellars should now be made safe against frost. Protect the house cellar, but provide for ventilation.

The Dwelling House.—Porches for protection to the front and back doors will cost but a few dollars. They should be made so as to be fastened to the house by a hook and staple upon each side, and removed in spring. Weather strips are rarely seen in country houses, but they save much fuel, and add to the comfort. A good substitute may be made by cutting sheet rubber into strips, and nailing them around the doors and windows. Let an ample supply of dry wood be kept in the kitchen.

The Stock.—Liberal feeding is now needed. No stock should be allowed to lose now what they have made in the summer. On the contrary, they should be kept growing. And they may be by proper feeding. "He becometh poor that dealeth with a slack hand," is very true in this respect. There must be close attention to this matter, or money is lost in feed and in weight of stock. Don't trust too much to hired men or boys. Have exact measurements for the feed. A box to hold three quarts, should be in every feed bin. This makes a fair allowance for one ox or horse, or for two cows or four calves at each feed. A bushel basket of fine cut hay is an average for one horse or cow, or two calves at each feed. There should be no waste, but as much feed given as will be eaten up clean. Give salt regularly in small quantities, or have it accessible to the animals.

Milk cows will suffer from chapped teats, if they are not wiped dry after milking. Some warm water, a piece of soap, and a dry cloth, should be taken to the stable at every milking time. The teats and udder should be washed and wiped dry, previous to and after milking. If the teats are chapped, some fresh lard will soften and heal them.

INDEX TO "BASKET," OR SHORTER ARTICLES.
Apple Pomace... 446
Barn Plan... 446
Bushes, How to Kill... 447
Carpet, a Faded... 447
Christian Advocate... 447
Crop Prospects... 448
Exhibition at New South Wales... 448
Fair in Indian Territory... 447
Fair, Nevada... 447
Farming in N. C... 446
Filling the Agriculturist... 447
Good Books Pay... 446
Gov. Lands in Iowa... 447
Grass Seed, Sowing... 447
Hog Crop... 448
Home-Made Fertilizers... 446
Horticulturist, Death of a Venerable... 447
Hurdles for Sheep... 447
Invaluable Help... 446
Jersey Cattle, Information as to... 447
Many for One... 447
Mass. Horticultural Society... 447
No Fawcett Words... 445
Paris Green, Use of... 447
Plant Named... 447
Poultry and Market Gardener... 448
Poultry for New York Markets... 447
Poultry, Lice on... 446
Premature Blooming... 447
Reading Advertisements Pays... 445
Rolling Horse... 446
Rust on Wheat or Oats... 447
Sick Fowls... 447
Small Steam Engines... 447
Sowing Down New Land for Pasture... 446
Sundry Humpbugs... 445
Timber, Time to Cut... 447
Timber, to Make Durable... 447

Sufferers by the Grasshoppers or Locusts.—Though the accounts as to the extent of the damage by the insect visitation to some of our Western States are very conflicting, yet there is no doubt much suffering, and apparently more than can be relieved by local aid. It will be well in this holiday month for the prosperous to remember those who are suddenly deprived of food, or the means of procuring it. If all who have friends in Kansas, Nebraska, or other devastated States, would remember and help relieve their necessities, much suffering would be avoided.

Cheat all Around.—Some one sent to a wise man of Philadelphia a head of wheat, on which grew some cheat, or chess. Wise man sent an account of this wonderful freak of nature to the Tribune, which that paper was innocent enough to publish. Then some one did—what most persons would have done at first—give the specimen a careful examination. It was found to be a cheat in every sense of the word, made up, bogus. —Moral: Don't be in a hurry to announce discoveries.

As to Onions.—"G." Savona, N. Y. Onions could doubtless be made profitable as a field crop, but the cultivation would necessarily be simply enlarged gardening. It is useless to try to raise onions by the use of swamp muck, lime, or any such partial fertilizers. Plenty of good well-rotted barn yard manure will bring a crop on good loamy soil every year upon the same ground. No rotation is needed for onions.

Newly calved cows should be guarded against cold, and their drink should be slightly warm.

Sheep.—Irregular feeding will show in the wool. Every time the sheep falls off in condition, there will be a weak spot in the fiber, and the wool will snap there when stretched. Wool buyers don't neglect to look for this, and the wool loses 5 or 6 cents a pound in value, where they find it. Regularity in poor feeding, is not so bad as good and bad feeding alternately. The sheep do not suffer so much. Half a pint of grain a day will keep sheep in good condition, with good straw or sweet corn-fodder. A little sulphur in the salt is a preventive of "stretches," which is simply indigestion.

Corn-fodder.—When carefully cured, corn-fodder is by many regarded next in value to hay. To throw it in bundles into the yard, to be picked over and trampled under foot, is wasteful, and it is a nuisance when the manure is to be moved in the spring. When cut in a fodder cutter, a bushel of it mixed with meal, (1 to 3 quarts), makes an ample feed for a horse or cow. Stock may be kept in good condition with no other fodder through the whole winter, with great economy.

Fattening Animals.—There is a point beyond which it does not pay to feed either hogs, sheep, or bees. When they fall off in their feed, feed is wasted. As long as young animals will eat well, it may pay to keep them. But full grown animals when fully fat, will eat and eat and keep stationary. It is well to keep a watchful eye upon such.

Ditches.—Wherever water stands upon wheat or rye fields, furrows or ditches should be made to let it off. Drains should be made or looked to before the ground freezes up.

Pasturing Grain.—As a rule, too much of this is done. But where the wheat or rye is very thrifty, a few sheep may be allowed to run over the fields without injury. Where the grain is heaved with the frost, coming soon after a rain, a flock of sheep will trample thousands of the plants into the soil again.

Manure may be hauled at any time, but it should usually be spread as it is hauled, and not left in heaps.

Work in the Horticultural Departments.

With this month the out-door work is practically closed. An unusually mild season may prolong it a few days, or an open spell allow something to be done to facilitate spring work, but for the most part, the horticulturist may leave his orchards and his beds, and turn his thoughts towards another year. Those who have read the Ogden Farm Papers regularly, will recollect the account of an ignorant chap, who was fleecing farmers out of handsome fees by tasting their soil, and telling them how to improve it. The desire to improve, to make their soil more productive, on the part of the farmers, made the work of this plausible quack an easy one. If the writer of this should go among orchardists, market gardeners, or florists, and tell them that for \$1, \$1.50, or some such sum, he could show them how to make or save \$10, \$20, or more, he would, no doubt, find a large number to invest. He does that here, and charges nothing. His secret is, buy one book relating to your specialty, and study it. The editorial correspondence of the paper all comes under the writer's eye, and he is quite sure, from the questions asked, that not one in ten, who are trying to make money by growing fruits of various kinds, by vegetables, or by flowers, have a modern work upon their branch of horticulture. We do not write this because the publishers of the paper also publish books, but should say the same in any case. We are glad to answer questions in cases of particular difficulty, but can not write treatises. Nothing is more common than for us to receive a letter, asking us to tell "all about" this or that, which could not be told did we give the whole paper to it. Every year there come questions about pruning trees and vines, about budding and grafting, about cuttings and layers, which if answered as they come, would make it necessary to reprint the same matter year after year. We can understand

how this happens; hundreds, if not thousands, who have never taken a similar paper before, have a new field opened to them. They read that trees are grafted, and that vines are pruned, and raised from cuttings, and that there are many other horticultural operations they would like to know about. These things, while matters of course to many, are to these novices entirely unknown, and they wish to learn about them. Now a paper like the *Agriculturist*, can not keep repeating these fundamental matters, teaching A B C's, so to speak, to the minority, but must give agricultural and horticultural news, record progress, and show methods which presuppose a knowledge of first principles. Those of our readers who take a political paper, do not expect that it will give the Declaration of Independence, or the Constitution of the United States, in each issue; and their religious paper goes upon the belief that its readers know something of the Ten Commandments, The Sermon on the Mount, and other essential parts of the Bible. So we must assume that our readers know the simple operations of horticulture. The publishers have taken pains to procure the best general and special works in all departments of agriculture and horticulture. But "the cost"—that is the objection. We have cited the instance of the successful quack; with such fellows farmers do not find it difficult to pay the money, because they impudently promise much. We can not raise high hopes, and tell our readers that by buying such or such a book, they will make \$50, \$100, or more, but we have not the least doubt that any standard work to any farmer or gardener, will ultimately be worth these sums. It comes in our way to read all books upon rural matters that are published, and we have rarely met with one which, however crude and poor as a whole, did not have some suggestion or idea in it, that was worth the price of the book. Now when we come to the best books on horticulture, we are very sure that they are worth many times more than they cost. In fact, any one engaged in any horticultural pursuit for the purpose of profit, cannot afford to do without the best thoughts, the costly experience of men who have devoted their lives to, and have been successful in these very branches. It is as much a necessary part of the outfit, especially of a beginner, as trees, plants, seeds, implements, or manures; indeed, all these are comparatively worthless without the necessary knowledge to use them. We hold it to be quite impossible for one to intelligently start, and carry on to profitable results an orchard or fruit garden, without some such work as Barry's, Fuller's, or Thomas's; if he would make a vineyard, he must consult Fuller or Husmann; he can not know how to raise vegetables profitably, unless he is familiar with Henderson, Brill, and Quinn; and does he propose to raise florists' plants, or cut flowers, Henderson's Practical Floriculture, is of as much importance to him as a greenhouse. These are only some of the leading works; there are others, general and special, which with these, will be found in the book list in the back part of the paper. But books are of no use unless studied, and now is the time to study. Get the boys interested in them too. If you wish to graft, and do not know how, get Barry, or Thomas, and practice the various kinds of grafting, on fresh cut, useless limbs; let the boys try now, and then give them a chance in the spring. A few good books upon fruits, will do more than anything else to keep boys interested in the farm, and contented to stay there. Read, study, and when you find something not provided for in the books, we will try to help you, but we can not continually teach the simplest operations of horticulture.

Orchard and Nursery.

Trees, especially young ones, need looking after, to prevent injury by rabbits and mice. Fences and gates should be repaired and closed, to prevent cattle from entering and destroying the trees. When light snows fall, tread down around the trees to keep away mice. A mound of earth around the trees is useful for this purpose, as well as to keep newly set trees in place during high winds.

Rabbits are best kept from injuring trees, by sprinkling blood on the trunk. A wash of cow dung, sulphur, and loam, is reported as useful.

Pruning may be done during mild days, but for larger limbs it will be better to wait until towards spring. Cover large wounds with gum-shellac varnish, melted grafting wax, or paint.

Cions.—Cut when the trees are not frozen, tie in small bundles, and store in saw-dust in the cellar. Earth will keep them from drying equally well, but saw-dust leaves no grit to dull the knife.

Drains for surface water should be provided; a young orchard is often severely injured by lack of care in this matter.

Root-Grafting.—Stocks should have been taken up before freezing weather. If not done, make use of the first open spell. Store in earth in the cellar, where they will be accessible for grafting during the winter.

Seeds of stone fruits should be buried at once, if not already done. Place small quantities in boxes of earth and set where they will freeze.

Fruit Garden.

Raspberries.—If not already done, bend down and cover the canes of the tender varieties, if the ground is still open.

Grape-vines should have been pruned last month, but advantage may be taken of the mild weather of this. In Northern localities, young vines, even of hardy sorts, will fruit better if they are laid down and covered.

Strawberry Beds should be given their covering of leaves or straw, just before the ground freezes. Two or three inches is sufficient, as the object is to protect the plants from sudden changes of temperature, rather than to exclude frost.

Wood for rustic work, may be cut and prepared for use next season. With a little skill in arrangement, many ornamental articles may be made for the flower garden and lawn. Posts and stakes should also be prepared; locust, red cedar, and chestnut, are all good, the first two sorts remaining sound for many years. All wood for posts ought to be seasoned under cover if possible, and so piled up that there will be a free circulation of air around and through the pile.

Spade up all ground between rows of fruit trees, and apply well rotted manure.

Kitchen Garden.

But little can be done here, except to look after the frames and pits, and care for seeds, etc.

Cold-frames.—Do not cover until freezing weather comes, and even then air should be given during the middle of every mild day.

Roots.—If plenty of marsh hay or leaves are at hand, it is well to cover a quantity of parsnips and salsify, so that they can be dug from time to time as wanted; they are much better than poorly kept ones. To keep roots properly in the cellar, they should be stored in earth, and if the house cellar is used, secure ample ventilation.

Spinach.—It is better to cover with leaves all beds which are to be left for next spring's use, except where the winters are mild.

Lean-poles should be properly cared for under cover. When sheltered they will last for several seasons, and if of oak, walnut, or red cedar, they will easily last for a dozen years. Pea-brush usually has to be renewed every season.

Rubbish.—If there is no snow on the ground, all weeds, brush, and rubbish in general, may be cleared up and burned, and the ashes spread or saved until next spring.

Seeds.—Thrash out and clean all seeds that remain uncared for, and label with date and name of variety. Keep in a cool place where there is no danger from mice.

Trenches or pits, where roots are stored, will not need covering until freezing weather comes, and then only gradually, just enough to keep out frost.

Flower Garden and Lawn.

Climbers, not perfectly hardy, should be taken from the trellises and covered with leaves or earth.

Trellises which are movable, should be taken down and stored under cover, those which are permanent should have a good coat of paint as a preservative.

Pits where plants are stored for the winter, need ventilation, except during unusually severe freezing weather. Apply water only sparingly, and when absolutely needed.

Protection.—The same general directions apply to giving protection to half-hardy shrubs and trees, as were given for strawberries. Tender roses are protected by laying down and covering with sods.

Evergreens.—Young trees will sometimes die for want of a little protection, when older ones of the same varieties will stand even a much lower degree of temperature. A slight covering with evergreen boughs, will be of much service for this purpose.

Leaves.—Gather all the leaves that are found on the lawn, and store in a dry place for use as bedding or protection. If there are leaves near at hand in the woods, as many as possible ought to be gathered and stored for winter use; they rot readily, and make valuable manure. They will be needed in making hot-beds in early spring.

Greenhouse and Window Plants.

Ventilation is one of the most important things to look after at this season, as by a little injudicious opening of ventilators, many choice plants may be ruined. Always open on the side opposite to that from which the wind blows. When the weather is very cold and freezing, air enough will enter through the little cracks to afford the necessary ventilation.

Water.—Apply only when the soil is dry, and then give an abundance, otherwise the plants will soon perish. Shower the foliage once or twice a week, except during the coldest weather.

House Plants usually suffer from the dry dusty atmosphere of the rooms in which they are placed. If showered occasionally, and the thick-leaved kinds wiped off with a damp sponge, they will grow much better.

Wardian Cases, or ferneries, are now in general use among plant lovers, as they enable one to grow a few ferns and other plants very readily, and with but little attention, except to shade from the direct rays of the sun. But little water is needed after that given the plants when first set out; if any mold appears the case should be opened for an hour or two every day.

Bulbs that have made good roots, may now be brought up from the cellar, and in six weeks time will give an abundance of flowers.

Succulents.—Echervias and tender sempervivums, will winter in a cool part of the greenhouse, if kept dry. Water should only be given sparingly.

Cactuses coming into flower, will require plenty of water, and those at rest scarcely any.

Insects should be looked after closely; give the house a thorough smoking once or twice a week, to kill the green-fly, and other pests.

Commercial Matters—Market Prices.

The following condensed, comprehensive tables, carefully prepared specially for the American Agriculturist, from our daily record during the year, show at a glance the transactions for the month ending Nov. 13th, 1874, and for the corresponding month last year:

Table with 2 main sections: 'TRANSACTIONS AT THE NEW YORK MARKETS' and 'Comparison with same period at this time last year.' Columns include Receipts, Sales, and various commodity prices like Flour, Wheat, Corn, Rye, Barley, Oats.

Table titled 'Stock of grain in store at New York.' Columns: Wheat, Corn, Rye, Barley, Oats, Malt. Rows: Nov. 9, 1874; Nov. 10, 1873.

CURRENT WHOLESALE PRICES.

Table of current wholesale prices for various commodities. Columns: Oct. 13, Nov. 13. Rows include Flour, Wheat, Corn, Rye, Barley, Oats, and many other goods.

Gold has been up to 110 1/2, and down to 100 1/2, closing November 12th at 110 1/2, as against 110 1/2 on October 12th. The dealings in most kind of produce, have been on an enlarged scale, but values have shown much irregularity. Prices of Flour, Wheat, Corn, Rye, and Oats, have been quoted lower, on more urgent offerings of supplies, leading to a fairly active business.

a rule, and in instances stronger and buoyant. The trade call has been somewhat brisker, but considerable difficulty has been experienced in making purchases of any large amounts of stock, holders insisting on rates much above the views of buyers. The recent receipts of stock from all sources, have been very moderate, and present indications are not encouraging, as to the probability of additions to the supplies.

New York Live-Stock Markets.

Table of live-stock receipts and average prices. Columns: Week Ending, Receipts (Bees, Cows, Calves, Sheep, Swine), Average per Week.

Beef Cattle.—The market for beefs has been marked by considerable variation during the month, and on the whole has been the reverse of satisfactory to sellers. Opening with an active demand for good cattle, and a buoyant feeling generally, dealers were tempted to bring on very large supplies, which, in the second week of our report, broke the market entirely.

The prices for the past four weeks were as follows: Table with columns: Week Ending, Range, Large Sales, Average.

Milk Cows.—Cows have been steady, with fair demand and regular supply. Prices remain the same, at \$45 to \$80 for poor to choice cow and calf, and \$89 to \$103 for the best offered. Calves.—There has been a sharp business in good calves at full prices.

Recent Stock Sales.

For the past few weeks sales of Shorthorn and other stock have been very lively. Values do not seem to diminish, as the highest average yet made in England was reached at Mr. Cheney's sale. The first sale of importance in October was that at Holker, of the Duke of Devonshire's herd. Here from \$5,250 to \$5,775 was paid for Oxforde, and the average for 25 cows and heifers and 15 bulls was \$1,970 each, 43 head selling for \$84,690.

for \$10,000, an average of only \$175. The best bull, which is thought to be superior to any other bull of the breed now living, brought less than \$500; the cows sold for \$200 to \$300. A sale of 45 Jersey cattle, the property of Mr. Marjoribanks, of Bushey Grove Farm, brought from \$35 to \$355; only one cow reaching the latter figure. This herd sold badly, as it had been bred injudiciously, every other valuable feature having been sacrificed to color. Breeders may well be warned by this example.

The sale of the Waldberg herd of Shorthorns, of A. A. Conger, of Haverstraw, N. Y., at Chicago, resulted in an average of \$456, bulls selling from \$100 to \$900, and cows \$130 to \$1,800. Alexander Charles' sale of 71 animals brought an average of \$131. At several other sales in Illinois the average was from \$103 to \$231. At the sales of Kentucky Shorthorns, held through October, low prices were received for what is called unfashionable stock. At a joint sale of several breeders 35 animals brought only \$3,155, an average of \$90. E. G. Bedford's sale of 35 head brought \$58,530, the highest prices being \$6,000 for London Duchess 9th, and \$7,000 for 21st Duke of Airdrie. 119 head of Mr. B. B. Groom's sale brought an average of \$573, \$90 and \$2,550 being the extremes. Gag Bros. sold 57 head at an average of \$159. In all 690 animals were sold in October at 13 sales, and at prices which were remarkably reasonable, and which should be tempting to farmers who desire to improve their stock.



containing a great variety of Items, including many good Hints and Suggestions which we throw into smaller type and condensed form, for want of space elsewhere.

Remitting Money: - Checks on New York City Banks or Bankers are best for large sums; make payable to the order of Orange Judd Company. Post-Office Money Orders for \$50 or less, are cheap and safe also. When these are not obtainable, register letters, affixing stamps for postage and registry; put in the money and seal the letter in the presence of the postmaster, and take his receipt for it. Money sent in the above three methods is safe against loss.

N.B.—The New Postage Law.—On account of the new postal law, which requires pre-payment of postage by the publishers, after January 1st, 1875, each subscriber must remit, in addition to the regular rates, ten cents for prepayment of postage by the Publishers, at New York, for the year 1875. Every subscriber, whether coming singly, or in clubs at club rates, will be particular to send to this office postage as above, with his subscription. Subscribers in British America will continue to send postage as heretofore, for pre-payment here.

Bound Copies of Volume Thirty-two are now ready. Price, \$2, at our office; or \$2.50 each, if sent by mail. Any of the last seventeen volumes (16 to 32) will also be forwarded at same price. Sets of numbers sent to our office will be neatly bound in our regular style, at 75 cents per vol. (50 cents extra, if returned by mail.) Missing numbers supplied at 12 cents each.

Our Western Office.—Our friends in the West are reminded that we have an office at Lakeside Building, Chicago, Ill., in charge of Mr. W. H. Busbey. Subscriptions to *American Agriculturist* are taken there, and sample copies of the paper and chromo are delivered, and orders received for advertising on the same terms as in New York. All our books are on sale at the Western Office. Please call and examine, buy, subscribe, and advertise.

The American Agriculturist in German.—We ask the kind attention of our readers to the fact that this paper is also printed in German. Many of them may have friends, or neighbors, or working men of that nationality, who would be glad to secure such a Journal as this. The more important articles and the same illustrations are contained in the German edition, with a Special German Department by Hon. Frederick Münch, of Missouri, and the rates, single and club, are the same as for the English edition.

Save the Index Sheet, which is put loosely in this number, so that it can be bound or stitched at the beginning of the volume without cutting the thread.

See Page 469.



REMEMBER THAT NOW Your Subscription Has Expired,

(unless you have recently renewed it for 1875, or chance to be among the few whose time runs over into next year, of which fact you will be cognizant, without personal notice from the Publishers.)

PLEASE RENEW AT ONCE,

For the following Reasons:

1st.—If the subscriptions for 1875 are sent in the first week in December, it will greatly assist the Publishers in getting the names carefully and systematically upon the mail-books, so that the January number can be mailed promptly before the year closes—to the pleasure of all.

2d.—It will take no more time to attend to renewing to-day, than will be required next week or next month.

3d.—The motto of all connected with the *American Agriculturist* is "Excelsior," and the Volume for 1875 (XXXIV) will in many respects be superior to any previous volume—in engravings, in useful and interesting reading matter, etc.—for all classes.

4th.—In addition to the above "Reasons," we ask the following special favors:—Please invite your neighbors to join you in taking the paper. See advertisement "Subscribe Now" on third cover page. If you have German friends, or neighbors, or workmen, please let them know that the *American Agriculturist* is printed in German also, with the same illustrations, the more important reading matter, etc., besides a Special German Department by Hon. Frederick Münch, of Missouri, and that the German edition is furnished at the same rates, single and club, as the English edition.

5th.—TO-DAY is the best time to renew your subscription for 1875.



Reading the Advertisements Pays, whether one wants to buy anything or not. Every business man has his own way of setting forth his goods or wares, and studying these business announcements awakens new ideas in the mind of the reader. We have had some of our most valuable new business thoughts start up when running over advertisements on entirely different subjects. . . . There is one satisfaction in reading the advertisements in this journal, that is afforded in few other papers, viz., that the editors and publishers aim to shut out all unreliable and deceptive persons and things, so that one may read the business pages with confidence. . . . The advertising pages are in one sense a "Grand Bazaar," where sellers and customers may meet for mutual acquaintance, and consultation and discussion. We introduce the dealers to the readers, and whenever addressing these dealers, please let them know you formed their acquaintance in the *American Agriculturist's* Bazaar.

No Farewell Words.—Though this is the close of the year, we offer no farewell words, because we expect to meet all the members of our household at the beginning of the New Year. We try to consider every regular reader of this Journal as a member of our family, whose interests are to be jealously guarded and promoted in every possible way, and the multitude of kindly expressions of appreciation of this mutual relation, continually coming to us, are of inestimable value, and the greatest reward of our labors. We hope ever to merit this good will, and in the coming year we shall continue to spare no effort to increase the mutual respect and kindly feeling hitherto existing between the editors and readers of the *American Agriculturist*.

Clubs can at any time be increased by remitting for each addition the price paid by the original members; thus: a person having sent 10 subscribers in one club, for \$12, (\$13 including postage), may afterward send 10 more subscribers, with only \$8, (\$9 including postage), making a club of 20 at \$1 each, (that is, \$22, including postage). Postage, 10 cents each, must be sent additional to subscription price, with each subscriber.

This Month being the last in the year, is one in which we would be glad to clear off all accumulated correspondence, but we are unable to do this, as our basket is smaller in December, than in any other month. Pages for the index are taken from that part of the paper devoted to Basket Items. We must try some how to have a more capacious basket.

SUNDRY HUMBUGS.—In looking back upon the year, we cannot regard it as having been very prolific in the way of humbugs. But few startling new enterprises of this kind have been set on foot, and the old ones do not appear to have done a very flourishing trade. The "panic" of last fall, which had such a disastrous effect upon legitimate business, appears to have had its influence upon swindlers. The pretended dealers in counterfeit money have shown a remarkable falling off; in former years it was not rare for us to expose a dozen or twenty of these rascals every month, but now new names are very rare. The year has not been memorable by having any important law-suits brought against us, but the decision in the action brought against us by one David Richards, which was instituted earlier, but only closed in January last, is one of the greatest significance. Here we have, for the first time, from the highest judicial authority—the Supreme Court—an opinion which clearly shows the relation of journalists to the public, and gives emphatic support to those who, with honest intent, would shield their readers from the various schemes of quacks and swindlers of all kinds. While we do not court law-suits, as they take up too much valuable time, we are very glad to have been the means, through this one, of calling forth an opinion that will long stand as a terror to evil doers, and as an encouragement to those who expose them.

OUR COURSE NEXT YEAR will be the same that it has been in former years. Aided by a better knowledge of "ways that are dark" that experience brings, we shall unrelentingly pursue all open and covert attempts to defraud the people, all schemes for getting money without sending an equivalent; all lotteries by whatever name they may be called; all quacks who sell nostrums by acting upon the fears of the unfortunate, or hold out false hopes to the suffering—in short, all those persons and things which are collectively classed under the convenient name of "HUMBUG."

Perhaps there is no word in so general use, the origin of which is so little known. Several derivations have been given, but the most probable is that it is a modification of *Hamburgh*. During the Continental wars, so many false rumors came from that city, that when any startling intelligence arrived at London, the people said, "Oh! that's another *Hamburgh*"—and this, easily

changed to humbug, was used for impositions and frauds of all kinds. For many years the *Agriculturist* fought the army of humbugs alone and unaided, but it now and then receives a partial support from other papers, and a most excellent work was done when Congress made it a criminal act to send obscene literature and fraudulent schemes through the mail. Very active in this matter has been

THE SOCIETY FOR THE SUPPRESSION OF VICE.

Its agent and the special agent of the P. O. Department, a few weeks ago arrested a man for sending obscene matter through the mail; the prisoner tried to bribe Mr. Comstock to release him, and failing in this, he assaulted him with a knife, and inflicted wounds of such severity that for a while Mr. C.'s life was in great danger. The prisoner is now in jail, to be tried for a murderous assault, and as the matter occurred in New-Jersey, he is likely to get all the law allows, while on the other hand, the public have taken a new interest in the Society, and it will go on more vigorously than ever. These chaps fare quite as badly when they take the law into their own hands as when they appeal to the law in the regular way... It is especially necessary that an agricultural paper should

GIVE WARNING TO FARMERS

of swindling schemes, as their promoters well know that their chances are better among the honest and kind-hearted than they are with those who are known as "men of the world." A farmer living an isolated life, and receiving but few letters, naturally looks upon a circular, sent to him by mail, as a matter of no little importance. He is likely to feel flattered by the attention, and the very fact that some one in New-York, or other large city, should send to him, gives him a favorable impression.

In former issues we have told how these names are collected, and the following advertisement will show the manner in which they are offered to purchasers. We may remark that this appeared in what is called a "sporting" paper, the organ of prize-fighters, rat-killing matches, and similar "sports."

250,000 NEW, FIRST-CLASS ADDRESSES FOR SALE. Names of agents, canvassers, country people, and "good buyers" generally. Secured at great expense, and will be copied on sheets, wrappers, or envelopes, at a low figure. Warranted genuine, and none better. Address—Montgomery place, Boston, Mass.

The scheme by mail is no doubt plausible—they always are, and the man, innocent of all knowledge of the fact that hundreds of men get their living by cheating, is more likely than not—unless warned by some person or paper in whom he has confidence, to yield to the temptation thus presented. One of the exceeding pleasing things about our relations to our readers, is the friendly confidence with which they regard us. Almost every letter upon editorial matters, brings us some expression which indicates that it is not a mere business relation between us, but the writer speaks as one friend to another. Possessing this confidence, we have felt that our warnings and exposures of humbugs would be heeded, and we have the satisfaction of knowing both from personal intercourse and through correspondence, that we have saved

MILLIONS OF DOLLARS

to the agricultural community, and that the *Agriculturist*, had it done no other good, has in this been of real benefit to the farmer. Encouraged by this assurance from all parts of the country, we shall be after the whole swindling crew with a "sharper stick" than ever. We ask our friends to continue to send us information of all doubtful schemes, especially if they (as most of them do) hail from New York... It is hardly necessary to tell our old readers our opinion of lotteries. No matter with what sugar-coating covered, whether called "distribution," "gift-concert," or what not, each and all are to be avoided. If for an ostensibly good or charitable object, so much the worse for the object. No good thing can be really helped by a resort to gambling.

OPERA HOUSES

seem to be favorite prizes in these schemes. One is offered at Germantown, Pa., and it is said that the Grand Opera House, of Jim Fisk notoriety, is to be put up in a lottery. How the man is to be pitted who draws it. It has been an expensive failure from the first.

THE GENEVA WATCH CO.'S

circulars are still going around. In the first place, the name is a fraud, as there is no such watch company in Geneva, as is represented. We do not believe that a watch was ever "made by machinery" in Geneva, and that the watch is "endorsed by all the leading jewelers," is a barefaced lie. We have had so many complaints of this Geneva watch business, the parties receiving the money, and sending notice that the order will be filled in turn, that we advise all to let the concern alone.

A SWINDLER IN NEW HAMPSHIRE

one would think would be as rare as a white black-bird, but even in the Granite State the proverbial Yankee

"cuteness" does not save them. A venerable gentleman, with spectacles and cane, appeared at Great Falls. He wished to open some manufacturing establishment, and wished a partner with \$125 to engage with him. Venerable man got \$125, and left young partner with rent of building and other bills to pay. Now we don't say, it served young man right, but we do say that he paid \$125 for a lesson that he will not forget so long as he lives. Leaving the money out of the question, how can a sensible person associate himself in business with an entire stranger!... Complaints continue to come about that

TOLL-GATE FRAUD.

A chap advertises "The Toll-Gate, a prize picture, sent free." It is a card about 3x5 inches, with on one side a most doleful attempt at a puzzle picture, and on the other an advertisement of a book on physiology of doubtful propriety, to judge from the card. We have exposed this thing before, but complaints keep coming. Why not write to the Harpers, and other very good people, who publish the deceptive advertisement... In the medical line there are no more insidious things than

BITTERS.

We have often warned our readers that they were dangerous, as for the most part their activity depended upon alcohol in some form—usually poor whiskey, and that people were by their use led into dram drinking unknowingly. They are mainly poor liquor, with some cheap bitter and aromatic drugs, sweetened and colored, and put up with showy labels. If persons are to take liquor medicinally, they should know exactly what they are doing, and not have it smuggled into them under false pretenses. In Rhode Island there is a very stringent prohibitory law, and while liquor selling diminished, the sale of bitters went on increasingly. The sheriff had 35 of the popular kinds examined by a chemist, and found that the majority contained more alcohol than wine, and some, showing over 40 per cent of alcohol, were quite as strong as ordinary brandy or whiskey; even one that is widely advertised as "Vinegar Bitters," contained 7½ per cent of alcohol. There can be but little doubt that in the great majority of cases, these "Bitters" are taken solely for their alcohol, as we find those that are most popular in the market, are those in which the percentage is the highest. If one needs only the tonic effect of the bitters, they can be had just as well in a watery infusion. Our often repeated advice is to let all quack medicines alone, and in this category we include bitters.

An Invaluable Help in every Home is a large Dictionary—not merely a "pronouncer" and brief "definer," but one explaining fully the meaning of all words, whether ordinary or rare. Such a Dictionary, like Worcester's Great Unabridged, containing **1,854** large 3-column pages, with an immense number of engravings, is a most valuable source of condensed information on almost all topics, and will do very much to make all the members of a family intelligent. It is well worth a place in every house, and should be in every school-room without fail.—Many families have obtained free copies through our premium offer in years past, and hundreds, or thousands even, may do so this year. **BOYS** have been particularly successful in this way, and almost any enterprising youth can, by persistent effort, scarcely fail to collect the eighteen subscribers needed to get this prize free. The work of doing this will give him useful business experience. See page 469.

Barn Plan.—"Daniel Trimble." The particulars of the barn plan described in the *Agriculturist*, in December, 1872, can be given, if we are informed what is wanted. But they can not be sent by mail unless the address, which was omitted in your letter, is given.

Apple Pomace.—"W. F.," Luzerne Co., Pa. Apple pomace may be given to a cow in small quantities as a relish only. It is not suitable for feed, and should not be given in large quantities. It will help to increase the flow of milk only by stimulating the appetite, and causing a larger amount of other food to be digested and assimilated as nutriment.

Farming in North Carolina.—"J. W. B.," Statesville, N. C., sends an account of how he farms in North Carolina. He removed from the State of New York 4 years ago. He plows under a crop of cow peas, upon "old field" land in the fall, and with a light top dressing of stable manure in the winter, has produced 34 bushels of wheat per acre, while by April 1st, the next year, the clover was 12 to 18 inches high. The land is excellent for orcharding. Land sells for two to ten dollars per acre. There are no bridges in the country, the roads are good, and not one-third of the land is cultivated.

See Page 469.

GOOD THINGS VERY CHEAP.—We again remind our friends, (and by friends we mean all our Readers,) that there are in our Premium-List (referred to on page 469) many good things, things really useful and desirable, which they can all get at very little expense, if any. We have large plans for making this journal very good and very valuable to everybody during the coming year, and we shall surely put many items of information into the *Agriculturist*, that will each be worth far more than the small subscription price. Now it will not be much labor to talk this to others, and get a few at least to subscribe. For every list of names sent us, large or small, we offer good premium articles of various kinds. The Publishers having extraordinary opportunities to get these premium articles, can afford to give them as they propose, and take pleasure in seeing them distributed. Our friends know that we never mean to send out any articles but those that are good and every way reliable, and as represented. Please look over the list of Premiums, and each one favor himself, and us, by securing one or more of them.

Home-made Fertilizers.—"W. J. B.," Macon, N. C. There is no home-made fertilizer that can be profitably substituted for Peruvian Guano. The market value of guano is fixed according to the quantity of its chemical constituents which are available for manure. Any chemical substance, as salts, acids, or alkalies, valuable for fertilizers, have their value fixed upon the same basis. Nitrogen, phosphoric acid, or potash, has each its standard value, in whatever article or shape it may appear.

Clubs of Subscribers need not all be at one Post-Office. The reduction in price to clubs of four or more names, is partly made to encourage the getting up of large lists, and partly because it costs less to mail a large number in one package. But we do not object to names added from other Post-Offices, as such names usually soon become centers of other clubs. Names for Premium Lists may also be gathered at any number of Post-Offices, if all are sent by the same person.

Sowing Down New Land for Pasture.—"Granger," York, Pa. New land just cleared, may be sown down to grass without the intervention of any crops. Probably in this case it might do very well to seed down with a crop of oats thinly sown, not more than two bushels per acre, in the spring. For permanent pasture in your locality, we would use 8 quarts of timothy, one bushel and a half of orchard grass, and one bushel and a half of Kentucky blue grass per acre. The blue grass will not show much until the third year, after which it will form a considerable portion of the pasture, filling up the spaces left by the gradual disappearance of the orchard grass, and furnishing good late pasture.

A Rolling Horse.—"A. L. W.," Kittery, Me. If practicable provide a loose stall, that is, an enclosed roomy stall not less than 12 feet square, for a horse that has a habit of rolling, and use no halter, but leave him unfastened. Possibly the rolling is caused by irritation of the skin, in which case give an ounce of sulphur in the feed daily for a week, and feed bran in place of part of the corn. At the same time good currying and brushing would be a help. If a box stall is not convenient, as it frequently is not, tie the horse with a strong halter so short that he can barely lie down comfortably. A friend has a horse that persists in getting "cast" in any stall, which is prevented by the short tying.

Good Books Pay.—It will pay to supply yourself, your sons, your workmen, your whole family, with good books as well as papers. Your sons and your workmen will be kept from idleness and mischievous company; they will understand and respect their work more; they will gain new ideas, and learn to reason and think better; they will learn to make their heads help their hands; they will labor more intelligently, and be happier. See to it that interesting and instructive works are always at hand in your home. Look over the List of Books published every month in this Journal. It will pay to provide yourself, and each member of your family, if you have any, with good books, even if economy has to be practised in other directions, to enable you to do this.

Hurdles for Sheep.—"T. G.," Kittrel, N. C. Iron hurdles for folding sheep, may be procured of Yarnall & Trimble, 147 Front St., Philadelphia. These are very much more durable than wooden hurdles or netting, and can be as readily set up. Five-barred hurdles of this kind, would also be perfectly secure against cattle or horses, and would serve as good a purpose as any of the portable fences.

Rust on Wheat or Oats.—"T. S. C." There is no known remedy against rust, when it has once attacked a crop of wheat or oats. The only probable preventive is to sow a variety that is hardy and sufficiently vigorous to resist the attack of the rust fungus. There are "rust proof" oats, commonly sown in the Southern States, where this crop is subject to attack; and the hardier red and amber wheats do not suffer so frequently as the white varieties. The use of lime or salt as fertilizers, tends to prevent rust; but excessive heat, and a moist atmosphere just at the season when the grain is filling, appears to be a frequent cause against which no preventive or remedy is known.

Don't fail to Read what is said about Light Work and Good Pay for December, on page 469.

To Make Timber Durable.—"W. V. S.," Lebanon, Tenn. The durability of timber is much increased, by soaking it in strong limewater for a few weeks, and then exposing it to the air under cover, to be seasoned. Fence posts should be stripped of their bark before steeping them.

Lice on Poultry.—"T. S. C." There is nothing in the feed either to cause or to prevent lice on fowls. Lice will only breed where fowls are not kept clean, or where they are neglected. A very effective remedy is to clean the houses thoroughly, and to apply lard or linsed oil to the perches, and beneath the wings of the fowls.

The Fair in Indian Territory.—The first fair of the Territorial Agricultural Association was held at Muskogee, the last week in October. It was a combined effort on the part of the civilized tribes, and brought out a fine show of horses, hogs, and poultry, with a limited display of farm utensils of native manufacture. The attendance was very good, and addresses were made by prominent Indians, as well as by persons from other States. As there is included within the Territory a large extent of the finest farming lands in the West, this fair cannot fail to exercise a good influence in having these lands improved. We congratulate the managers on the success of this, their first exhibition.

Sowing Grass Seed.—"T. S. C." Grass seed may be sown at any time during winter, upon the snow or frozen ground, if that is more convenient than sowing it upon the soil in spring. The seed lies uninjured until spring, and falling into the minute cracks made by the frost in the ground, it becomes well covered when the soil thaws.

A Faded Carpet.—"A Young Housekeeper," Chicago, Ill. experimented in cleaning her carpet with damp salt. The carpet is ingrain, drab and green, and the salt was dampened and sprinkled over it, as sawdust is used in sweeping carpets. At first glance the carpet was, in appearance, clean, fresh, and new, but as the dampness left it, the bright green changed to a dull dark shade, and no amount of sweeping could change it. The present color is not pleasing, and she asks what she can do.—Whether anything can be done to restore the color, will depend upon the character of the original dye. She had better consult some competent dyer.

Time to Kill Bushes.—"T. S. C." The best time to cut brush, is when in full leaf. At that time the shock is often sufficient to kill the plants. If cut now, the roots will sprout in the spring, and become even more trouble to destroy than before cutting.

A Venerable Horticulturist Gone.—The Gardener's Chronicle, of Oct. 3d, contains an interesting obituary of one of the best of the nurserymen of the old school, in England, (the father of the editor, although that is not alluded to), viz: the venerable William Masters, of Canterbury. He had reached the age of 78 years, and as the nursery and garden was that of his father before him, he must have been one of the very oldest of English nurserymen, as he certainly was one of the most scientific. He was an accomplished landscape gardener in earlier days, and an ardent lover of the natural history sciences and geology, at a time when they were not so popular as they are now; he exerted himself vigorously to form a museum in his native city, and for

years acted as its curator, delivering lectures on botany and geology, and making his nursery a supplementary feature, by arranging it in part as a botanic garden. In former years he was a frequent and valued contributor to the natural history and horticultural magazines and transactions, was an esteemed citizen and magistrate, and had been the mayor of his native city. The writer of this notice retains a delightful memory of the great and unaffected intelligence, active kindness, and urbanity of the excellent old man who has now gone to his rest at a good old age. A. G.

In addition to the above appreciative note by Prof. Gray, we may say that at the time of his death, Mr. Masters was the oldest member of the Royal Horticultural Society.

Time to Cut Timber.—"T. S. C." Timber, when its durability is the chief consideration, is generally cut in midsummer or in midwinter; cut then the seasoning process in more rapid and perfect.

The Mass. Horticultural Society has recently elected Mr. Francis Parkman, Jr., as its President. Mr. Parkman is a worthy successor in the line of distinguished horticulturists who have held this office, and it is one of those rare cases in which the giver and recipient are both honored. Mr. Parkman has made for himself so honorable a name in literature, that we are accustomed to look upon him as the brilliant author, rather than as a quiet practical horticulturist, who finds relaxation from the labors of the study in those of the garden. This election is a proper tribute to the worth of one of the most modest of the many cultivators who have made Boston the horticultural center that it is.

Government Lands in Iowa.—"J. W. C.," Jersey City, N. J. The few lands belonging to the U. S. Government left in Iowa, are located in the north-western portion, and are situated far from railroads and towns. These are not by any means the cheapest lands for a settler, even when he gets them for nothing. The time lost in going back and forth to a depot, or town, 10 miles distant, every year, will easily pay the interest upon the cost of a farm at \$10 per acre; and the choice lands near towns can be bought from railroad companies for that price, on long time. The Burlington and Missouri Railroad Co. have some choice land in Iowa.

The Christian Advocate, also offers a premium of "Merely Knocking at the Wicket Gate." It has been highly commended as a work of art. A subscription to the Christian Advocate will be a cheap mode of securing a beautiful picture.

Poultry for the N. Y. Market.—Unless those who send poultry to the New York market, comply with its customs, they had better send it elsewhere. In former years we have given full directions for preparing poultry, and now remind readers of the essential points, by publishing the following condensed directions, which come to us in a timely circular, from the old poultry house of E. & O. Ward, 279 Washington street. "To insure highest market prices, poultry must be well fattened; crops empty when killed; kill by bleeding, but do not remove the head. Have them nicely and well picked; skin not broken or torn; entrails should not be removed; thoroughly cooled, but not frozen. Pack in boxes, with a layer of clean straw (rye straw the best) between the layers of Poultry, in the same posture in which they roost. Mark each box, specifying what it contains. Send invoice by mail. Ship to reach us about the middle of the week—should never reach us so late in the week as Saturday.... Greatest demand on special occasions. Fine fat turkeys for Thanksgiving. Prime and nice geese for Christmas. Extra large and nice turkeys for New Year's day. On all these occasions shipments should reach dealers two to five days in advance.... If you cannot find any profit in sending prime quality and well prepared, you need not look for any in ordinary or poor qualities."

The Use of Paris Green.—At the meeting of the Academy of Science, held early in November, Dr. John J. Le Conte read a paper upon the use of Paris Green for killing injurious insects, especially the Colorado potato-beetle, and presented the subject in a manner calculated to create alarm. Dr. Le Conte is a high authority in his specialty, entomology, and admits that the chemical aspect of the subject must be developed by his colleagues. The paper itself, and the discussion which followed it, show that really learned men, such as compose the Academy, do not know everything. This, which may be considered our highest scientific body, is gravely told—what every farmer who reads the papers knows—that Paris Green is sold by the ton. One member had heard of the loss of human life from its use to kill cockroaches, another announced the fact, which has

been in all the papers for these many years, that poisoning had resulted from using wall paper colored with Paris Green. The use of strychnine to kill crows, was thought wrong by another member, and the whole discussion was more befitting the N. Y. Farmer's Club, than the Academy of Science. Not one of the learned gentlemen present, seemed to know of the experiments of Prof. Kedzie, of the Michigan-Agricultural College, and none of the eminent chemists of the Academy explained what changes the poison underwent in the soil, but after wasting time in censuring the Agricultural Bureau at Washington—by which we suppose the Department of Agriculture was intended, and that is past all censure—the Academy adopted a resolution, appointing a committee to investigate and report upon the use of this and other poisons to kill insects and other animals, for the ornamentation of articles of food, coloring of paper, etc. We shall gladly welcome any addition to our knowledge in this direction, but as this matter of use of poisonous colors in confectionery and on wall paper, has been done over and over again, it seems very funny to see our savans taking it up as something new.

The Nevada Fair.—The first exhibition of the Nevada State Agricultural and Mechanical Society, held at Reno, during the third week in October, was entirely successful. There was a show of good stock, and the exhibition of fruit, grain, and vegetables, shows that the new State so celebrated for mineral wealth, can take fair rank as an agricultural State.

Filing the Agriculturist.—"D. E. C.," Traverse City, Mich. On reference to almost any volume of the *Agriculturist*, the estimate for the cubic measure of the ton of hay might be found. For timothy well pressed down, 500 cubic feet is allowed, and when not solidly packed, 600 feet is generally taken. A large number of requests come to us for information or advice, which could be easily procured by consulting the index of any volume of the *Agriculturist*.

Sick Fowls.—"H. P.," Clinton Co., Iowa. When fowls appear out of order and lose appetite, a change of food is often sufficient to restore them. The food should be mixed with a little linseed meal, and a small quantity of pepper and a small piece of coppers dissolved in their drinking-water would be useful. Fowls suffer more from want of clean water, and from badly ventilated and unclean roosting places, than from any other cause.

The Methodist and its Premiums.—The Methodist offers as premiums for new subscribers, the portraits of the late Dr. T. M. Eddy and the Rev. Alfred Cookman. An interest in these notable ministers is felt not only by Methodists, but by persons of other denominations, who were permitted to listen to their eloquence, and mark their pure and noble characters. The portraits themselves are fine specimens of the engraver's art, and can not fail to be acceptable and popular.

Don't fail to Read what is said about Light Work and Good Pay for December, on page 469.

Small Steam Engines.—"V. A. W.," Forsythe Co., N. C. The most compact, best finished, and safest engine we know, is the Baxter Engine, made by the Colt's Arms Co., Hartford, Ct. A cheaper engine, made by Whitman & Barrell, of Little Falls, N. Y., was described and illustrated in the *Agriculturist* of June, page 212, 1874.

Many for One.—Mr. W. R. Pease, showed us five ears of pop-corn from one stalk, which in the whole contained 3,454 grains. A goodly number to be produced from a single seed.

Information as to Jersey Cattle.—"I. M.," West Farmington. It is very strange that you have not found information as to the Jersey cows in the *Agriculturist* any time these few years past. Very many numbers will tell you that they are most valuable for a butter dairy. They are not the cows for cheese making. For that purpose the Ayrshire are preferable, or else the Dutch cattle.

Plant Named.—"C. P." The plant found in your cranberry plantation, is *Lycopus Virginicus*, the Bugle-weed. Quite common.

Premature Blooming.—Maj. John W. Beeks, Galena, Kas., sends specimens of cherry blossoms which were picked in the middle of October. He states that the warm weather and the showers, make the season like the month of June, and that many fruit-trees are in flower. This is bad for next year's crop.

The Hog Crop.—A report from 214 points in the chief pork producing States, states that in 159 places hogs are fewer than last year, in 27 places about the same as last year, and in 28 places more than last year. Of corn the same report states, that in 100 places there is less, in 79 more, and in 35 about the same as last year. The quality of hogs is reported as uneven.

Crop Prospects.—As regards the prospects of the newly sown wheat crop, both here and in Europe, there has rarely ever been a better promise. The weather has been remarkably favorable for seeding and the growth of the plant. So favorable has the season been at the East, that so late as on the 5th of November, more than one farmer of our acquaintance has sown wheat. From all parts of Europe a similar condition of the weather is reported. Of course this has a depressing influence upon the market, the extent of which it is impossible to forecast. One thing at least is certain, that the favorable condition in which the fall wheat crop meets the winter season, can only tend to affect the market unfavorably for sellers.

The Exhibition at New South Wales.—The Journal of the Agricultural Society of New South Wales contains the programme for the Metropolitan Inter-colonial Exhibition, to open at Sydney, April 6, 1875, in which a very full list of prizes is offered in both the agricultural and non-agricultural divisions. At the request of the Secretary, we cheerfully call the attention of our inventors and manufacturers of farm implements and machinery to the liberal prizes that are offered, and to the fact that competition is open to exhibitors from abroad. The Secretary thinks that a large market would be found for our machines, were they only known in the colonies, and states that all articles may be sold after the exhibition. By way of San Francisco, Australia is now much nearer to us than to the mother country: our letters now come to hand in forty days from their date, and as their agriculture is more like ours than that of England, the colonists find our implements and our papers better suited to their needs, than those of that country. We notice by the journal of the Society that steps have been taken to insure a representation of the Australian colonies at Philadelphia, in 1876. The Secretary of the Society is Mr. Jules Joubert, Sydney, N. S. Wales.

Poultry and Market Gardening.—“S. W. L.” Although you send stamp for a reply by mail, we cannot answer by letter, as we do not know where you live. You omit to state your residence, and the post-mark has not a distinguishable letter. Poultry cannot be successfully kept upon a large scale, unless the fowls have a wide range. There can be nothing more destructive in a market or any other garden, than a flock of fowls—even a small one. Unless the birds can be kept out of the garden, one or the other must be given up. Market-gardeners near New-York have all they can do to attend to gardening only, and then work more hours in the day than do most other people. We never give advice upon buying land, or the price to pay for it.

See Page 469.

Bees Notes.

BY M. QUINBY.

A friend in New Orleans, says: “Will you be so kind as to give through the *American Agriculturist*, your way of putting glass boxes on the side of combs.” Of course the most convenient way to do this, is with movable combs. The comb well fastened in frames, should stand on the bottom board, independent of the outside, as described in the *Agriculturist* for June, 1873. Have the sides of the hive out of the way, until the boxes are placed. My Cherry Valley friend has furnished for market over 40,000 lbs. of honey the present season, most of it in glass boxes, that hold a little over 4 lbs. The depth of the boxes is about 5 inches, length 6, width, 4 inches. Top and bottom are of wood, the sides of glass. The glass in the end that comes next the comb, reaches only about two-thirds of the way across the end of the box, leaving three-fourths of an inch on each side for the bees to enter. Imagine a comb standing upright of itself, all you have to do, is to set the box by its side, with the narrow glass towards it, so that the bees can enter. If the frames are 16 inches long, four boxes 4 inches wide, will just fill it out, and if 10 inches deep, two courses high will be just even with the top, eight more can be set on the other side, and eight on the top of the frame. These top boxes have holes through the bottom for the bees to enter. All of them may have inch holes without detriment, and then the boxes may be changed from side to top as required. Just these sizes

of box and frame, are not used in all cases, but the principle can not probably be bettered. Have the size of frames and boxes to correspond, and all alike for every hive in the yard, so that any box will fit any hive, and any frame of comb will fit any place. There is time now to think what hive is best to start with in the spring. Study the principle, and get ready now, or at least before spring.

At the discussion at the N. Y. Central Fair, at Utica, it was stated that some bee-keepers had furnished honey for market by the car load, the question was asked, how was it obtained? The answer was by cultivating bees. Then came the question, “What is meant by cultivating bees?” A partial explanation gave rise to questions innumerable, as “what is an improved hive?” “Why do you get more honey than we used to?” “What do you mean by raising queens?” “What by movable combs, and what is gained by them?” “What about Italians, are they better?” “How do you tell one kind of egg from another?” “How do you tell when they are going to swarm?” “How do you make artificial swarms, are they as good?” “How do you extract, when was it found out, how long have you done it?” Of course these questions, and others growing out of them, could not all be answered for want of time. How to prevent getting stung, seemed to be the main one. The fear of stings seemed to operate more than all else against beginning to keep bees. After it was explained that we work by quietly using smoke, and avoiding harshness, and that we need not get stung; it was announced that Mr. Quinby had a hive of *live* bees on the fair ground, and would illustrate the manner of handling at such an hour the next day. He attended, and went through with many manipulations, such as taking out the combs—without protection for face or hands. He exhibited every bee, and sealed and unsealed honey; he then found the queen—which a great many had never seen before, never daring to look so close to so many bees. The quantity of honey necessary for winter, was pointed out, etc. The combs were returned to the hive, and not a bee was made angry, nor was any one stung. No smoke was applied further than to show how easily it could be used in case they had been angered by an unlucky jar, or a bee pinched a little. It was claimed that any one, that could operate carefully, and especially without fear, would be equally successful. But few besides those having some experience with bees ventured to attend. On this point we need different training. We must disabuse the growing mind of this awful fear. It is the duty of the agricultural press generally, and of farmers who wish to save half of the immense honey waste of the country, to do something. Change the teaching. If a boy can be taught to risk his life at the cannon's mouth, to accomplish and bring about a wished for event, it ought to be easy to learn him to brave a bee sting, for the accomplishment of a great work.

Ogden Farm Papers.—No. 58.

As before intimated, I visited the St. Louis Fair, and, incidentally, saw a good deal of Western agriculture. The fair is entitled to all the encomiums it has received on the score of “bigness.” The extent of the exhibition, and of the crowd gathered together, is quite as great as has been claimed for it. The quality of the exhibition, too, is of great interest, though in most departments there was a lack of orderly arrangement, and an absence of systematic labeling, which detracted very much from its value to one who for the short time allowed desired to examine it carefully, and compare different articles of the same class with each other. The cattle of the different breeds were not separated, and in looking over the Jerseys, for instance, one had to skip about among stalls occupied by animals of half-a-dozen breeds. The implements and machinery were placed very much at random, and it was sometimes difficult to learn anything about particular entries, and always troublesome to compare them with their competitors. The \$11,000 offered as premiums for cotton attracted a wonderfully fine show from all the cotton-growing States at the Southwest.

I have been told that the St. Louis Fair was mainly a horse fair, and that its agricultural features were comparatively insignificant. This I did not find the case. There was a great deal

of trotting and running, and an interested throng looking on, but there was only a half-mile track; there were no very noted horses, and this feature of the exhibition seemed rather a subordinate one. In position and prominence it was much less conspicuous than the show of implements and machinery in motion, and on the whole the exhibition was not at all open to the criticism of being a “horse-trot” under the name of an “agricultural fair.” Indeed, it is not especially an agricultural, but rather a general industrial exhibition, the agricultural features of which are prominent. It serves its industrial purposes remarkably well; but as a fair, as a means for attracting an immense congregation of holiday visitors, I have never seen its equal. On the principal day there were over 100,000 visitors to the grounds, and a more orderly, happy, interested, and cheerful gathering one could hardly hope to find.

Aside from the horned cattle, the feature which most interested me was the good display of windmills. Many of these were excellent, and some of my old friends among them seemed to hold the prominent position they deserved, but I was especially taken with a new-comer, the “Enterprise,” which, for simplicity, efficiency, and I should say for durability, seemed to have advantages over all I had yet seen. It has the merit of being cheaper in first cost than any other of like character, and I shall pursue my investigation with a practical trial of its ability to turn our seaside winds to profitable account, and to withstand their tempestuous attacks.

AN ILLINOIS BUTTER DAIRY.

One leading object that led me to the West was the butter dairy of I. Boies & Son, Maren-go, Ill., concerning which I have several times written in these papers. My visit here was entirely satisfactory. The dairy-building described in a previous number has not yet been constructed, but in all other respects I found the accounts to be not at all overdrawn. There are now on hand about 100 milking cows, 60 of these had come in since August, and the others were expected to calve shortly. The cows are natives—or rather, they are such cattle of mixed races as are kept throughout northwestern Illinois, where dairying is the prominent industry over a very wide area. I can best describe their quality by saying that I have never seen twenty natives together that would average nearly so good as the whole hundred in this herd, which has been built up by a system of careful selection. Mr. Boies says he generally finds that he can buy a dairyman's best cow for five dollars more than the market value, and it is his practice to drive frequently about the country buying all the remarkably good cows he can find, and selling the poorest ones of his own herd. He has had the skill to carry on this system until he must have collected on his place most of the best cows within his reach.

The amount of butter made, per cow, has thus far been only estimated, but careful accounts are now being kept, and will be carried on throughout the year, so that we shall know pretty nearly what the possibilities of such a herd are. The method of feeding has been sufficiently described in my previous articles; the principle on which it is based is, that a milking cow should eat all that she can possibly be induced to eat. Mr. Boies is very strongly of the opinion that it is impossible to get the fullest profit from a butter dairy, or from any other, without having the cows come in in the

autumn. He then carries them through the hight of milking on high winter feed, and finds that when they are five or six months gone, and would naturally begin to fall off in their yield, the flush of the May and June pastures gives a fillip to their production, and carries them up pretty nearly to their full yield again,—by the time the summer drouth pinches the pasture, they are ready to be dried off for their next calving. This, in connection with the fact that the winter market is best for butter, makes his course seem judicious, and worthy the attention of others. Cows coming in in the spring give more during May and June than autumn calvers do at any time, but when they begin to feel the effect of their next pregnancy, there is only winter feed to be given them, and this does not sustain their productiveness as grass would do.

A very large item on this farm is the feeding of pork. Shoats are bought in fair store-hog flesh, are very highly fed on skimmed milk and corn, and are drafted for the market when in good selling condition. There is generally a profit of about one cent per pound on the original purchase, and the average increase of weight is 20 pounds.

The following experiment shows the profit of the operation, and indicates the care with which business details are attended to on this farm: June 12th, 10 average hogs were bought, weighing 1,850 lbs. They cost \$87.87½ (\$4.75 per hundred pounds). Corn cost 56 cents per bushel; skimmed milk, 20 cents per hundred lbs.; meal and bran, 1 cent per lb. August 3d, after 52 days feeding (the cost of feed being \$41.81), they had gained 975 lbs.—the increase costing \$4.29 per hundred lbs. They were then sold at 6 cents per lb., making a profit of \$39.82, to say nothing of the manure. They feed every year about 1,500 hogs, to which they add about 90 tons weight of pork.

I was enabled to see the whole operation of skimming, churning, working, salting, re-working, and packing the butter, the whole being done in a most systematic and business-like way, and the product being of first-rate quality for a dairy of common cows. The butter is of capital flavor and of good color. It lacks the firm texture of Jersey butter, and they are now considering the question of buying a Jersey bull, and raising the heifer calves from the best twenty of their own cows. If this course is carried on for a few years, there will be at Marengo a butter dairy herd that will be hard to equal.

The following account, received from Mr. R. Q. Tenney, of Colorado, is gratifying as confirming a theory which I have proved in practice to be a sound one, and have earnestly recommended:

"I wish to thank you for your article published in the winter of 1871, on transplanting mangels and sugar beets. I have probably saved to myself from \$150 to \$200 in the past three seasons, by following your directions. The first two seasons one of my neighbors, an old Iowa farmer, ridiculed the idea, but he was compelled to "acknowledge the corn" when he saw the result. This year a late frost killed, say three-fourths of the plants in my seed bed, and being so far from a base of supplies, had not time to send for more.

"Another time I will not be in so great a hurry to plant, as I find that they do not require a very long season.

"I transplanted from the 15th to the 22nd of July, and have fine beets, although the grasshoppers hurt them some.

"We are getting a good number of Jersey cattle into the Territory. I think I imported the first, and now have a fine bull, three years old Feb. 11th last."

FINE HERDS AT THE WEST.

While at the West I visited some of the principal Jersey herds in my line of travel, and, indeed, extended my journeying for the purpose. I was less gratified by the condition of my own animals in Illinois, than I hoped to be. The protracted early drouth drying up the pastures, and reducing all farming in southern Illinois to a very difficult pass, had the effect of pulling down their condition until I regretted having exhibited them at St. Louis. Their plight at least had the advantage of proving that with Jersey cattle, as with all others, good keep is necessary to good condition and good yield. Realizing the state of affairs, I turned on more steam, and had the satisfaction of seeing them at once improve, and I hear that they are now in much better order than at any time since June.

At the large and splendid blue-grass farm of Major Campbell Brown, at Spring Hill, Tenn., where a wide range had made up for the effect of the drouth, the Jerseys, (of which he has a very fine herd), were in excellent condition, and were yielding largely. Mr. Hardin, of Louisville, who has very little land, and depends mainly on purchased food, has his animals in fine order. Several breeders in the immediate neighborhood, have capital herds, and it is evident that here, as well as about Cincinnati, the Jersey is as great a favorite, and is as abundantly distributed about summer residences, as even about Boston or Philadelphia. The best cow I saw during my travels, is "Dinah," owned by John L. Stettinius, of Cincinnati, whose whole herd is quite worthy to be in the same pasture with her.

I advise all Eastern farmers who desire to remain content with what they have at home, and to bear with equanimity the six months of winter feeding that our climate makes necessary, to keep away from Mr. Alexander's 3,000-acre farm, of Woodburn, in the blue-grass region near Lexington, Ky., where animals can graze during nearly the whole winter; where the pastures are greener and more beautifully wooded, than any which we know; where the rarest animals, representing hundreds of thousands of dollars, are kept under circumstances of ideal perfection; and where our most enthusiastic dreams of pastoral life and profitable farming, are blended in a tantalizing reality. Whoever visits Woodburn, buys a few hours of delight at the expense of months of unsatisfied longing—tempered, however, with the influence of an example that is full of suggestive details, which cannot fail to have an effect on his future plans and aspirations.

I receive from all parts of the country, reports of success with Jersey cattle. Mr. F. M. Churchman, of Indianapolis, writes, that he has a heifer, only two years old last spring, which made in the flush of her milking, 12 lbs. 3 oz. of butter per week, and now, seven months after calving, is making over 7 lbs. per week. She is probably one of a small herd, and well kept, but this report is only a specimen of those frequently sent me, and they indicate that success with Jerseys, is by no means confined to the older breeders of the Eastern States; they seem perfectly adapted

to all parts of the country, and they are doing everywhere, all that could be desired to sustain the commendations which have been bestowed upon them by their admirers.

Of home news we have little worth reporting. The season has been exceptionally cool and moist, and we have had much dark weather. The grass crop was large, but the grass has been less nutritious than in warmer and brighter seasons. The cattle have shown the effect of this in their production of butter, although in as good condition as usual. We have more hay than ever, and for the first time I think, although our herd is large, we shall be able to go through the winter without buying. Our butter throughout the season, has been, if possible, better than ever before, and the quantity and flavor hold out remarkably well, as we have at this writing (Nov. 2nd) had no frost, and the grass is very fine.

It will be impossible this year to report the amount of our production per cow, with any approach to accuracy, for the reason that the sale of skimmed milk has become a very important item of our business, and we have frequently skimmed after twelve hours' standing, in order to supply the demand; being sure of a profit on our purchased milk, even if only partly skimmed, we have made more or less butter, according to the requirements of our market for butter or milk, and the butter product per cow for the year, would probably make a less favorable showing than in the report for 1873. We have recently sold five of our most important cows, and, pending the selection of good Herd Book successors to take their places, we shall buy fresh native cows, and force them to the greatest possible extent with corn meal, getting all the butter from them we can, and turning them off fat in the spring for the butcher.

Heavy Shorthorn Grade Cattle.

In the *Agriculturist* for March 1870, there were published portraits of four heavy fat steers, raised by Mr. George Ayrault, of Poughkeepsie, N. Y. On the first page of the present number will be found portraits from life, of two heifers and two steers, which are even more remarkable than those of 1870. These are also raised and owned by Mr. Ayrault. The two heifers are shown in the upper part of the engraving; that upon the left hand is the "Queen," said to weigh 3000 pounds. Of the two steers below the heifers, the one in the foreground is the "Champion," said to weigh not far from 4000 pounds. All these cattle are high grade Shorthorns. As to their pedigree, or the particular strain from which they originate, no particulars have been given. They are all six years old, and for the first three years were not forced in any way. They were not suckled by a nurse, nor did they suck two cows. Indeed, they were weaned at less than a week old, and after the first two months, received only skimmed milk, with a handful of wheat shorts per day. After four months they were weaned from milk, and were fed upon pasture, with a sufficient quantity of grain in the winters to keep them constantly growing. Since then they have been fed upon pasture, with hay from early cut grass, in summer, and in winter, the same kind of hay with 8 to 10 quarts of corn and oat meal per day. Sugar beets and sweet apples have been given to them occasionally, but only in such quantities as

would serve as a relish and provoke an appetite for their regular food, and aid its perfect digestion. These cattle were exhibited in September, at the Western N. Y. fair at Rochester, at the Central N. Y. fair at Albany, and at the first exhibition of the Hudson River Agricultural Association, held at Poughkeepsie in Oct. At the last named fair they formed the chief attraction, being near home, where the animals were well known and popular. During the month previous to this they traveled 1000 miles, and, under good management, lost little or none of their weight. The "Queen" and the "Champion" are to be fed another year, with the intention, if possible, to make them the heaviest heifer and steer that have yet been raised. It is probable that the steer is now heavier than the famous "Ketton ox" which was raised by Mr. Chas. Colling, one of the early English Shorthorn breeders, in 1796, and weighed 3780 pounds alive, when 6 years old. We should judge by the handling of "Champion," that he can be made considerably heavier than he now is. It would do much to make Shorthorns popular, if breeders would feed either pure bred animals or high grades in this manner for beef frequently, and give less attention to mere pedigree. If high pedigree stock does not produce cheaper or better beef than any other, it is difficult to fix wherein its excessive value lies. The butcher's block is, after all, the final criterion by which high and low bred alike must be judged. The sight and touch of a living animal are both greatly inferior to the final test of all—the dressed quarters. Farmers who feed beeves look to this test for their profits, and if they are frequently made acquainted with such samples of what Shorthorn blood can produce, as are here illustrated, they will be the more ready to invest in the purchase of bulls than they now are.

An Easy Wagon-Spring.

"Torsion" is the act of twisting, just as one twists or wrings a wet cloth to get rid of the water. The resistance of a steel rod to torsion, and the force with which it springs back to its place, are very great. The strain upon the fibers of the metal is much less in this case, than when a piece of steel is bent, and a torsion spring is therefore one of the most elastic and

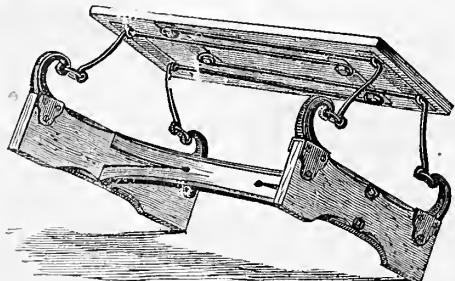

Fig. 1.—TORSION WAGON-SEAT SPRING.

durable known. A wagon or seat-spring, made upon this torsion principle, by Schenck & Sheri-

dan, of Fulton, N. Y., is here illustrated. The seat-spring is shown in fig. 1, and it is, upon trial, found to be remarkably easy. It is calculated to bear any weight up to 800 pounds, without losing any of its elasticity, or breaking. Figure 2 shows a spring intended for a wagon-



J.W. Fasel

A CALIFORNIA WEED—DODDER UPON ALFALFA.

body. It is calculated for a weight of 800 pounds to each spring. Two will thus bear 1600 pounds. A spring for wagon-tongues is also made upon this same principle; it is said that there are some thousands of railroad cars now running, which are furnished with springs of this kind. In a recent test a set of springs were taken from beneath a car after three years' use, and were as perfectly elastic as when first put in. The strength of springs made upon the torsion principle is so great that one made of 3/4-inch steel-bar will bear a load of 7,000 pounds, and still be perfectly elastic under it.

A Dangerous Weed in California.

Improved agriculture is of so recent a date in California, that but few of the pests in the way of insects and weeds that trouble the cultivator in the older States, have come to plague his California brother. Alfalfa or lucerne is one of the staples of Californian agriculture, and a weed that threatens the destruction of this crop, is a matter of the first importance. Notices of a particularly troublesome dodder have appeared in the California papers, and we are indebted to the kind attentions of our friends of the Pacific Rural Press, of San Francisco, and of the Sonoma Democrat, for specimens, and to make an engraving of it. Almost every

one knows our common dodders, which hang their yellow or copper-colored, wiry stems over the bushes in the swamps of the Atlantic States. There are ten native species east of the Mississippi, several more west of that river, and about seventy species thus far known throughout the world, all of which, with their varieties, are admirably described in Dr. G. Engelmann's elaborate account of the genus. The dodders are all parasites; the seed germinates in the ground, and the stem attaches itself to some other plant; by means of numerous disks or suckers, it draws upon the other plant for nutriment, and soon cuts itself loose from the root, and feeds wholly upon its unfortunate host. Some dodders live upon exogenous plants indiscriminately, while others prefer particular plants, or those of certain families; one confines itself to flax, which, besides the one in question, is the most generally injurious. One of our native species has been known to be troublesome upon young trees in nurseries. The dodder upon alfalfa, so far as we can determine from description, having no authentic specimens for comparison, is *Cuscuta racemosa*, variety *Chiliana*. The species is a very variable one, and between it and related species there is some confusion. The seeds of this were no doubt introduced into California with alfalfa seeds from Chili, the same as it was into Europe many years ago, where it was very destructive to lucerne, often destroying whole fields. The engraving shows the habit of the weed; when once fixed, it spreads and entangles the several branches of a plant, or those of neighboring plants; under this heavy draught made upon its life-blood, as we may regard the sap, the lucerne ceases to grow, and at length turns yellow, and dies from exhaustion. The Sonoma Democrat publishes an opinion that the dodder now so troublesome upon the alfalfa is a native species, but an examination of the specimens makes us quite sure that it is not. One not acquainted with the minute characters, by which the species are distinguished, might, from their outward resemblance, regard them as the same. At the lower left hand of the engraving the relative size and shape of the two seeds are shown, both of course magnified. The alfalfa seed is like a minute, rather flattened, kidney bean; that of the dodder is irregularly orbicular, and only about one-third as long as the other. An ordinary magnifier will readily detect the presence of this or other foul seeds in the alfalfa seed. With this, as with other weeds, one important point is to avoid introducing it, and care in selecting the seed will do this. Where it makes its appearance the most prompt measures should be taken to prevent its spread. Cut the infested plants, and burn them, and do this before the parasite has matured its seeds. If the dodder has too full possession to allow this to be done, then the plan followed in France, (where a dodder, and probably the same species, is destructive,) may be adopted. Straw



Fig. 2.—TORSION WAGON-BOX SPRING.

is laid in abundance among the plants in a dry time, and is then set on fire; the sudden flame destroys the parasite, but does not materially injure the alfalfa, which starts from the roots, and the stems, that escape injury by the fire.

The Badger Hound, or Basset.

When we advocate, as we have often done, stringent dog-laws and their strict enforcement, it is not from any antipathy to dogs. There are dogs and dogs, and we make a distinction. That some dogs are not only pleasant and companionable, but highly useful, we have no more doubt than that the great majority are useless and injurious, and should be taxed out of existence. Upon a farm, especially, a good dog is valuable, and if its value includes an ability to aid its master in hunting, all the better, for there are many more farmers who need the recreation that hunting affords, than there are those who neglect their duties and waste their time with the gun. Believing in the utility of some dogs, we regard the introduction of a new and meritorious breed as a matter of sufficient interest to give a portrait of a Badger hound, which is sufficiently rare in this country to be regarded as new, as there is only a small pack of them owned by a German gentleman in Hoboken, N. J., and a few others scattered about the country. This dog is known to the Germans as *Dachshund*, or badger hound, and to the French as *Basset*, and if we accept the descriptions given by writers of both these nationalities, it possesses a remarkable combination of excellencies. There are two divisions of the breed, those with straight and those with crooked legs, the last-named being preferred. The general appearance of this dog is not prepossessing; as Gayot, the great French authority, remarks, it is more strange than graceful; the head is long and pointed at the muzzle, and the ears very long, so that when the animal is running they touch the ground; the neck is thick, body long, and the tail long and slender; the legs are remarkably short in proportion to the body, the fore-legs being singularly bowed, while their large feet turn outward; the hair is short, and usually with brown or black markings on a white ground. On account of

their shortness of limb, these dogs are only 13 to 16 inches high, and for the same reason they run slowly, and the hunter can keep up with them without difficulty. Their expression of countenance is peculiar, it being an oldish and at the same time attentive look. They

furnished by the friend who shot the specimen. Naturalists at present separate the Rails into two genera, the old genus *Rallus*, including the Virginia, the Clapper, and the King Rails, while the common Rail or Sora, the Black Rail, and the present species, are in the genus *Porzana*;

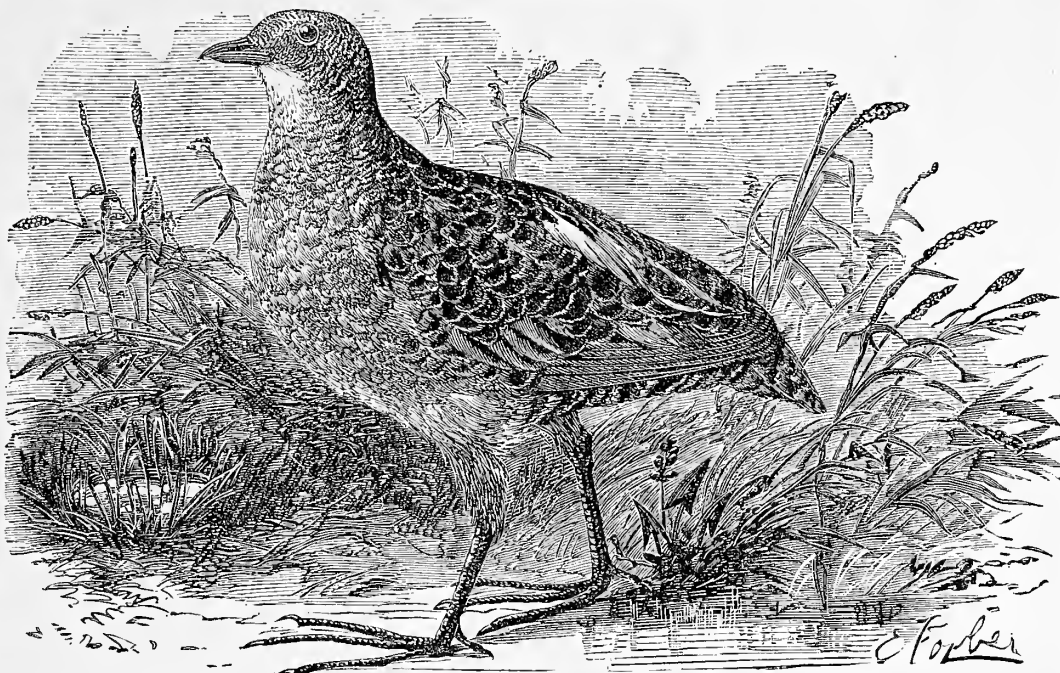

YELLOW-BREADED RAIL.—(*Porzana Noveboracensis*.)

have a keen scent, and in Europe are used for hunting almost all kinds of game, especially rabbits and deer, and such is their courage that they will even attack the wild boar. They are regarded as especially valuable in destroying all animals that are injurious to the farmer.

The Yellow Breasted Rail.

One of our associates having had the good fortune to bag a Yellow-breasted Rail, we

reddish, with spots of white; chin white; thigh feathers blackish; line over the eye cinnamon brown; length from tip of bill to tail, about six inches. This, the smallest of the Rails, is so retiring in its habits, and skulks so persistently among the reeds and tall grass which border the water courses and drains of our meadows, that it is very rarely obtained, and therefore the least known of its kind. The writer, in an experience of twenty-three years' shooting upon meadows and marshes,

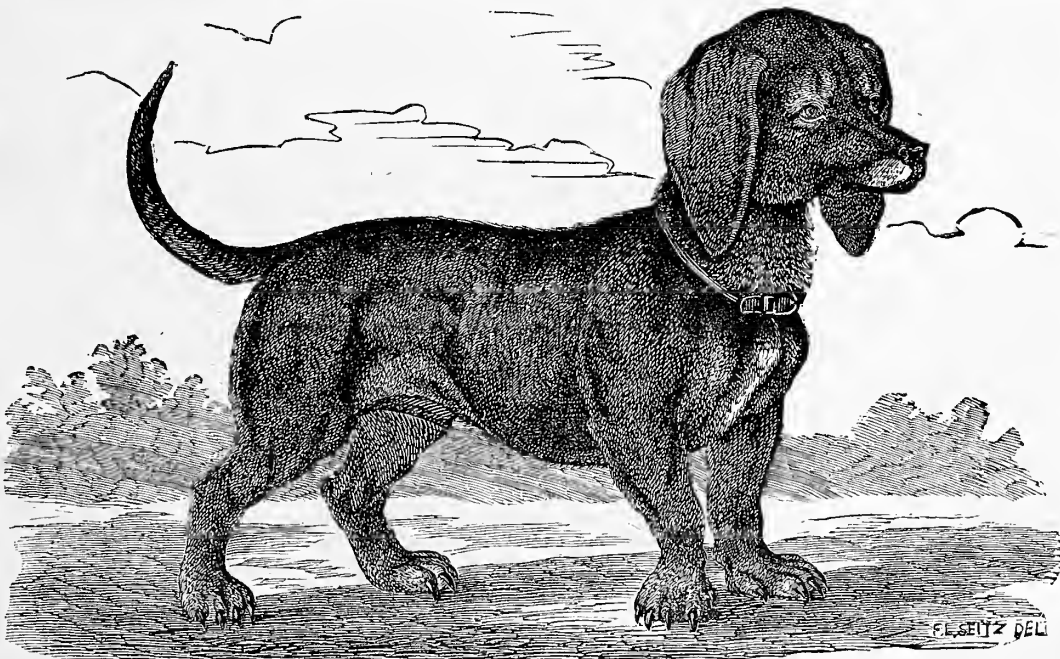

THE BADGER HOUND, DACHSHUND, OR BASSET.

have had an engraving made of the specimen. Those interested in birds, either as objects of natural history or as game, will be glad to know something of this, one of the rarest of all Northern birds, and we give the following account of it, mainly from notes

has obtained but two in all that time, and has heard of but two others being shot, one at Gravesend, L. I., and the other on the salt meadows of the Hackensack, N. J. The Yellow-breasted Rail takes wing very reluctantly, and will only rise when hard pushed by the dog; it then flies but a few yards, with neck outstretched and legs hanging down, and soon drops among the tall reeds, where it runs with such amazing swiftness, that further pursuit is useless. It is chiefly met with

by Snipe shooters, when in pursuit of their favorite game. As this bird bears a considerable general resemblance to the European Quail, it was called by one naturalist (Latham) the Hudsonian Quail. It lays from ten to sixteen pure white eggs among the grass, making no nest—or at

all events such a rude attempt, that it can hardly be called one. Although so rare a bird at the North, it is more common in the Southern States. Audubon states that he found it at all seasons of the year in Louisiana, where it builds a nest, and raises two if not three broods in a season; he regards the fact of its not building a nest at the North, as evidence that it has strayed beyond its proper limits; yet they are found as far north as Hudson's Bay. The flesh of this bird is highly esteemed. Early in the morning it makes a peculiar cry, which has been compared to that produced by the striking together of two pieces of stone, some liken it to the sound of flint and steel, and others say that its note resembles the croaking of a tree-toad. It makes its appearance near New York early in the spring, and remains until the frosts come, when it disappears suddenly, as is the habit of all the rails. The specimen here figured, was shot in the month of September, of the present year, on the meadows back of Bergen, N. J. Its food consists of aquatic insects and seeds.

Walks and Talks on the Farm.—No. 132.

[COPYRIGHT SECURED.]

The Deacon came in the other evening to talk over matters, and I said to him:

"Here is something, Deacon, that ought to please you! Prof. Daniels delivered an able address at the Wisconsin State Fair on *Hard Times—A Cause and a Remedy*."—"It would please me," said the Deacon, "to hear of a remedy."—"We must first ascertain the cause, Prof. Daniels attributes it mainly to a great over-production of wheat and corn in the Western States. I will read you what he says:"

"The present condition of Western farmers was long ago predicted, if they continued to depend upon the production of corn and wheat for their revenue. In 1864, the Superintendent of the Census said: (*Agriculture of the U. S. Census, 1860, p. 42.*) 'For some time before the war our Western farmers were beginning to complain that wheat-growing was not profitable, that the cost of transportation left them barely enough to meet the cost of production—and it was argued, wisely as we think, that it would be more profitable to grow less wheat and raise more cattle, pork, and wool, the cost of transporting which, in proportion to value, is much less than that of a more bulky produce. * * * The Western farmer, for a year or two, has been receiving high prices for his produce. *He would do well fully to understand the causes which have led to this result.* They are by no means permanent.'

"Speaking of the increased demand for wheat then existing, he says, it 'will for some years, probably, keep prices high enough to make wheat-growing in the West exceedingly profitable. The time must be expected, however, when the Western farmer will again find the cost of sending wheat to the Eastern cities, and to Europe, so high as to leave him barely margin enough to pay the cost of production.' These," says Prof. Daniels, "wer timely words of wisdom. No one could to-day tell more surely what has become a sad reality in the West, than these words, written ten years ago, foretold would come to pass, should the course then pursued by farmers be persisted in."

The Deacon put on his spectacles, and drew near the lamp on the table. "Let me read that myself," he said. "I don't see what there is in that should please me."—"Why," said I,

"have you forgotten where those 'timely words of wisdom' came from? Prof. Daniels did not know that they were written in this quiet farm house. You and I talked the matter over again and again. 'No one,' says Prof. D., 'could to-day tell more surely what has become a sad reality in the West, than these words, written ten years ago, foretold would come to pass.' And yet some people are disposed to think a man can know nothing of farming unless he lives west of the Mississippi River. You and I, Deacon, worked at odd times over a year studying the Census returns, and making new tables showing how much we produced in the different sections, in proportion to population, in 1860 as compared with 1850. I was promised \$10 a page for the work. We prepared 130 large pages of the Introduction, and after it was printed I sent in my bill. They sent me a check for \$450, and said I should have the balance in a month or two. But I have never received another dollar. When we send more farmers to Congress and fewer politicians, you and I, Deacon, will present our claim. It has never been disputed. In fact it has been 'allowed'—but never paid."

"I did not know," said the Squire, "that the Deacon and you were able to tell ten years in advance what was going to happen."—"We can tell," I replied, "that if you neglect your farm it will not improve. If you starve your cows this winter they will not give a large flow of rich milk next summer. If you sow foul seed, you will not have clean crops. We know that if a young man spends his days reading novels, and his evenings at the tavern, he will not increase in knowledge and wealth. If you keep a young apple orchard in grass, and do not manure it, or if you sow it every year to oats, wheat, corn, potatoes, or rye, and take off the whole crop and put nothing back, we know that ten years from now your apples will neither be large nor fair, nor command the top price in market. We know that people will want something to eat, drink, and wear, and that wheat, potatoes, fruit, beef, mutton, pork, cheese, butter, and wool, will be wanted in the future as in the past. We know that, other things being equal, the farmer who can produce the best article at the least cost, will make the most money."

And now, while we are talking on this subject, let me predict again. Good farmers are going to see better times than we have had for some years. I do not know this, but all the indications point that way. The farmer in this section, and especially in the West, who drains his land, kills the weeds, cultivates thoroughly, gets his crops in early, and gathers them in season; keeps good stock, and feeds out nearly all that he raises; the farmer who makes rich manure, and saves and applies it judiciously, has a fair prospect of getting pay for his care, labor, intelligence, and enterprise. Good tillage, and rich manure should be our motto.

I have received a letter, commencing as follows: "A Committee was appointed by the Eastern Experimental Farm of Chester Co., Pa., to investigate the subject of Cooking and Steaming Feed for Stock."—Ah well, I said to myself, now we shall perhaps learn something definite in regard to this much discussed subject. It has been talked and written about for half a century or more. So much so, that when I see an article in any of our agricultural papers headed "Cooking Food for Stock," I invariably and by instinct skip it. Not that the subject is unimportant, but that until we get

some well-planned and well-tried experiments, all has been said for and against the practice that can be said. I was very glad to hear, therefore, that the Eastern Experimental Farm was going to investigate the matter. Prof. Miles, of the Michigan Agricultural College, is also about to make some careful experiments. But the more we have the better. Our Agricultural Colleges should work together. Each should know what the other is doing, and take up different branches of the same subject. But what is the next sentence in the letter? "They mean to make an exhaustive report, and take the liberty of asking you to have inserted in the *American Agriculturist* a notice of the same, requesting information from all quarters, pro and con, in regard to this matter."—And so, it seems this Experimental Farm is not going to make an Experiment on Cooking Food for Stock—they are to make an "Exhaustive Report." Please don't! Our agricultural papers are by no means destitute of enterprise. If there are any trustworthy facts, they will get hold of and publish them. We do not need Experimental Farms to do this kind of work. If we could get at agricultural facts by holding conventions, making reports, and passing resolutions, we should soon place agriculture on a scientific basis. I was once at a Meeting of the American Dairymen's Association, when the following resolution was offered and of course passed:

"Resolved, That this Convention is of the opinion that corn is a valuable product for the dairy-farm, and that we commend it as a forage crop."

I voted "aye," but I could not help thinking that one experiment would be worth a whole car-load of such resolutions.

"You believe in cooking food for hogs," said the Deacon, "your steamer seems to be going almost night and day."—Yes, but I am working in the dark and no "report" will give me light. I suppose cooking makes some kinds of food more easy of digestion. And when you are trying to push young pigs along as rapidly as possible, or when you are fattening well-bred hogs that can assimilate more food than they can digest, then cooking will probably pay. At the present time, corn is so high that we cannot afford to let any of it pass through the animal undigested. In fattening hogs, the great aim should be to make them eat just as much and no more than they can digest. There are hogs that can digest more corn than they will eat. In this ease there is nothing to be gained by cooking—unless it will induce them to eat more. I would give them all the cooked or fermented food they would eat up clean. I would then pour a little more into the trough. They will fight over it and eat it up. Then give a little more, and so on until you are sure they will eat no more of this cooked food. Then throw an ear of corn into the pen, and let them try to get it away from each other. Every extra ear of corn you can get them to eat and digest, will give you nearly or quite as much pork as the corn contains. A large proportion of the food of animals is used to support respiration and the vital functions. The growth comes from the food eaten and digested in excess of this amount. It takes some time and not a little sense to feed pigs in this way. But it will pay.

Now, on the other hand, if your pigs will eat more than they digest, there may and there may not be an advantage in cooking their food. If the cooking or fermenting will enable them to digest more food, then, at the present high

price of corn, it will pay well. "I don't think it pays at all," said the Deacon, "to feed hogs corn at present prices."—I think it does, but that is not what I meant. That is another question. What we are talking about now, is whether in case you feed pigs at all, it will pay to cook the food for them. It certainly will not pay to throw bushels of corn into a pen of coarse, ill-bred, ravenous hogs, and let them pass one-third or one-half of it undigested. A good appetite is a good thing. A good digestion is better—what we want in a pig is both.

"You have said this same thing over and over again," said the Deacon, "for the last 8 or 9 years."—Yes, and I mean to say it again and again. It must be understood before we shall make any real improvement in breeding pigs. Mr. LAWES has recently advocated the same doctrine, and we may hope that it will attract more attention. "From the results of numerous experiments made at Rothamstead," says Mr. Lawes, "it may be assumed that on the average, a pig weighing 100 lbs. will, if supplied with as much barley-meal as he will eat, consume 500 lbs. of it, and double his weight—that is, increase from 100 lbs. to 200 lbs. live weight in 16 or 17 weeks. The following table shows the amount of dry or solid constituents in the 500 lbs. of barley-meal, and how they will be disposed of in the case supposed :

500 LBS. BARLEY-MEAL PRODUCE 100 LBS. INCREASE AND SUPPLY.

	In food.			
	In 100 lbs.	In 100 lbs. of increase	In manure	In respiration, etc.
Nitrogenous substance.....	52	7.0	59.8	276.2
Non-nitrogenous substance...	357	66.0		
Mineral matter.....	11	0.8	10.2	
Total dry substance.....	420	73.8	70.0	276.2

"From the figures in the table," continues Mr. Lawes, "we learn that of the 420 lbs. of dry or solid substance which the 500 lbs. of barley-meal contain, about 74 are stored up in the 100 lbs. of increase in live weight, about 70 are removed in the manure, and 276, or nearly two-thirds of the whole, are given off into the atmosphere by respiration and perspiration"—that is to say, we expended this amount in the mere sustenance of the living meat and manure-making machine, during the 16 or 17 weeks required to produce the 100 lbs. of increase.

"But now," says Mr. Lawes, "let us suppose that, instead of allowing the pig to have as much barley-meal as he will eat, we make the 500 lbs. of meal last many more weeks. The result would be that the animal would appropriate a correspondingly larger proportion of the food for the purposes of respiration and perspiration, and a correspondingly less proportion in the production of increase. In other words, if the 500 lbs. of barley-meal be distributed over a longer period of time, it will give less increase in live weight, and a larger proportion of it will be employed in the mere maintenance of the life of the animal. Indeed, if the period of consumption of the 500 lbs. of meal be sufficiently extended, the result will be that no increase whatever will be produced, and that the whole of the food, except the portion obtained as manure, will be expended in the mere maintenance of the life of the animal."

"Why this," said the Deacon, "is precisely your old doctrine of the advantage of having animals that are 'great eaters'—a doctrine which is hard to swallow when corn-meal is \$2 per 100 lbs."—"No Deacon," I replied, "Mr. Lawes does not go as far as that. He does not

say, as I do, that there is an advantage in having an animal that will eat, digest, and assimilate a large amount of food in a given time. He says there is a great loss in not giving a fattening pig all the food he will eat, digest, and assimilate. I push the doctrine a step further, and aim not merely to give the pigs all they will eat, but endeavor to raise a breed of pigs that will eat, digest, and assimilate a larger amount of food, at the same time aiming to breed them of a quiet disposition, and with the least possible proportion of offal. I wrote my little book on the pig for the purpose of advocating this doctrine. If true of pigs, it is true of other domestic animals. I am very glad that Mr. Lawes has called attention to this subject. It is time we aimed to breed pigs that do not require two-thirds of all the food they can eat to 'run the machine.'"

Every year I am aiming to get less and less fall work. We are busier in October than any other month in the year. And it is work that *must* be done. The days are short, the weather uncertain, and wages high. We greatly need a good potato-digger, and a corn-husking machine. So far as I have seen, the machines now made for husking are too small and too slow. Farmers do not want more machines than they have now. We want to keep fewer machines of our own, and hire the work done by skillful men, who keep a large steam-engine and the necessary machinery for doing the work up rapidly.

"Your Late Rose potatoes," said the Deacon, "helped you forward with your fall work more than all the machines you are likely to get for some time." The Deacon is right. I have hitherto planted the Peachblow. It has been our surest and best winter variety. But it runs over the ground almost as bad as Compton's Surprise, and is hard to dig. Besides it is very late, and often keeps on growing until November. Two years ago, last spring, Mr. E. L. Coy sent me a peck of his Late Rose potatoes. I planted them in the mangel lot, where they had plenty of manure, and I had a great yield. The next year (1873) I planted half an acre or more side by side with Early Rose and White and Red Peachblows. The Late Rose were by far the best crop. I put over 100 bushels in the cellar, and thought nothing more about them until February, when, happening to be at New York, I called on B. K. Bliss, and had a talk about the new varieties of potatoes. I told him that I thought the Late Rose a decided acquisition.—"There are three or four kinds of Late Rose," he said. "Where did you get your's from?"—I told him Mr. Coy made me a present of a peck.—"Oh!" said he, "you got it from headquarters. Mr. Coy originated the variety, and you ought to take care of it."—On coming home, I found that these potatoes, being so large and fine, were decidedly popular in the kitchen, and that we had been eating them all winter. After that I made them eat Peachblows, and we planted this spring all the Late Rose we had left. As the Deacon says, this fact helped me greatly with my fall work. As soon as we were through digging the Early Rose, we commenced on the Late Rose, and were all through digging them two or three weeks before the Peachblows were ready. This is a great advantage.

I think the Late Rose will stand high manuring. And as the "bug" is upon us, this is what we want. We shall have to go over our potato field two or three times next year with Paris green. It will cost no more to go over an

acre of potatoes that will yield 300 bushels than over an acre that will yield only 100 bushels.

We should get our manure ready for potatoes this winter. I have commenced my pile already, and it is fermenting nicely, and will keep on fermenting all winter. But it is not yet too late to start a heap. All there is about it is simply to wheel the manure into a heap in some central position, and every day, or as often as the stables and yards are cleaned out, wheel the manure to the heap and spread it *on top*, instead of scattering it over a large surface.

If the manure does not ferment, it is probably because it is too poor. The droppings from the hen-house, if scattered upon the heap and covered up, will help it. When you kill pigs, save the blood and pour it on the heap. Any animal matter will be good. If the heap is dry and cold, the hot water, hair, etc., you have left after scalding the pigs, can be poured on the heap to advantage. In my case, the horse stable is separate from the rest of the buildings. We throw the horse litter into an empty stall, where it will keep dry. Every week or so we put this horse litter in a cart and draw it to the pig-pens. Here it stays until it gets saturated with the rich liquid from the pigs, and is then wheeled to the heap. There is no difficulty about getting such manure to ferment. It will be in prime condition for potatoes in the spring.

"I saw somewhere," said the Squire, "a plan of making rich manure, by putting plenty of straw in the stable and not cleaning it out until the spring."—That is the plan they call "stall-feeding" in England. The animal is put in a loose box and kept well littered. He moves about and keeps the bed level and solid. But in a cow stable, where the cows are tied up, you can not adopt this plan. In a large shed, or basement, where the animals run loose, the plan is a good one—and nearly all our farmers adopt it. The only objection to it is that the manure is not sufficiently rotted for spring crops. John Johnston adopts this plan, but he piles his manure in the spring and keeps it over the summer, to be used as a top-dressing on grass in the fall. The proper management of manure depends greatly on circumstances. The first point is to save all the liquid. The next is to keep the animals clean and comfortable, and the atmosphere of the stables pure. The next is to ferment the manure as much as possible without loss. If this can not be done to advantage, give it up. It is only a loss of time. It is using the manure in the fall instead of the spring; or using it in the green state for corn. The latter plan is the one generally adopted by the Deacon. I do not like it. I think, in my circumstances, my plan of fermenting the manure all winter in a heap, and turning it if necessary towards spring, is better than plowing under this long, strawy manure. It gives me manure in good condition for potatoes or mangels. But if the Deacon's plan is the only one you can adopt, you may console yourself with the reflection that there is no loss from fermentation or leaching. You get all the virtue there is in it, but you will have to wait some years before you get the full effect of the manure.

BEEF FROM COLORADO.—Dressed beef is now shipped in refrigerator cars from Denver, Colorado, to the New York market. Two cars recently arrived, which contained the carcasses of 34 beeves, 50 calves, 199 sheep and 20 ante-

lopes. It being well established that meat can be thus shipped either from Texas or Colorado to eastern markets, it is to be hoped that the transportation of live cattle, with all its cost to the owners or consumers of the meat, and all its misery to the poor beasts, may in time be made unnecessary.

A Self-Supplying Feed Box.

In the accompanying illustration is shown a feed-trough for poultry or pigs, in which a large stock of feed may be kept so as to offer a continuous supply. It consists of a square or oblong box, with a trough upon each side, or all around it, as seen at fig. 1. The box is raised a few inches above the ground, by the projection of the ends downwards. Spaces are cut in the sides, half an inch wide, and several inches

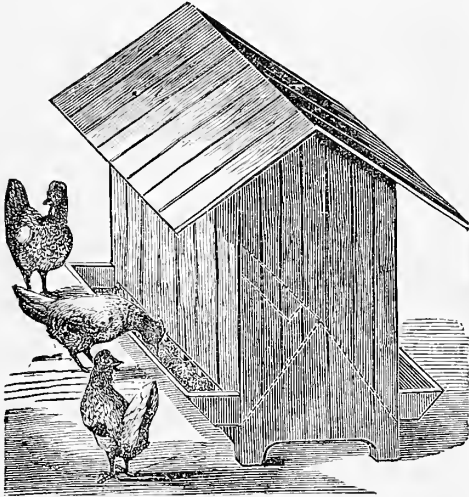

Fig. 1.—FEED BOX IN USE.

long, by which the grain escapes into the troughs. The floor of the box is made of two sloping boards, as shown by the dotted lines, by which the grain is made to fall towards the troughs. A broad-eaved roof is placed above to shed the rain. The box is filled by inverting it and opening a small door, shown in fig. 2, through which the grain is poured until the box is full. This contrivance will be found of great value

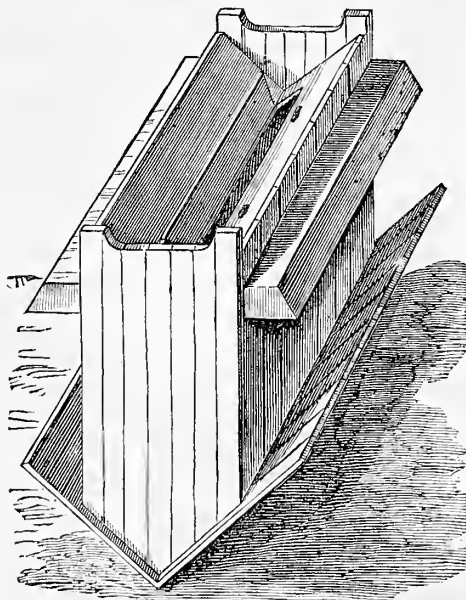

Fig. 2.—BOX INVERTED FOR FILLING.

in promoting the health of poultry, by ensuring a regular supply of clean food. Grain scattered upon the ground is likely to be picked up along with much filth and other matter, and frequent-

ly, without doubt, the ova of injurious parasites thus find their way into the bodies of the fowls. Where fowls are kept clean and cleanly fed, they are free from disease. "Gapes," pip, roup, and other disorders are in a great measure the results of uncleanness or infection thus engendered, and the fouling of the food or water by the filth of the yards, or that from the fowls' feet, is, without doubt, the most common cause of the ills of the poultry yard. In giving fowls a constant supply of food, there is no danger that they will over-feed themselves; on the contrary, it is when fowls are irregularly fed that they gorge themselves.

Horse Clothing.

A great many more horses are prematurely worn out by neglect than by hard work. Cold kills more than work does. Sudden chills, when they are warmed up by severe exercise, ruin numberless horses. In how few stables can a good set of blankets be found? These are always seen in the stables of valuable horses, but rarely elsewhere. But a cheap horse feels and suffers from sudden changes as much as a costly one, and humanity calls for proper care of such a one as much as for any other. Nor should the lap-robe, or the buffalo-robe, with which the driver protects himself, be used to cover the horse while he stands for a short time. This conveys the disagreeable smell of the animal's not always clean skin to the clothes, from which it is plentifully evolved and diffused when a warm room is entered. The horse should be provided with blankets for its special use. These need not be costly, and may be easily made at home. A pair of coarse, heavy brown wool blankets, costing \$5, will make a very serviceable suit of horse clothing. The clothing should be made in two parts, one to cover the back from the withers to the crupper and reaching beneath the belly, and another to cover the neck and throat; both should be lined with gunny cloth to strengthen them. The neck and chest of a horse are very sensitive parts of the animal, and need ample protection as well as the body. The body clothing should be made of two pieces, cut so as to admit of two gores; one short narrow one upon the rump, and one longer wide one at the withers. These should be cut so that the blanket fits smoothly to the curve of the back, else it will not lie in its proper place, but will slip down and gather in wrinkles in the middle of the back. A saddle piece of stiff cloth should be stitched upon the blanket, and two slits worked in it upon each side, through which the girth is placed to retain it in its place. Two straps and buckles should be stitched in front to fasten the blanket close upon the chest, and it should be bound with a broad strip of colored flannel. The throat-piece should be carefully cut to fit the neck, and be made low

enough to lap over the blanket for several inches, as is shown by the dotted line in the illustration. A strap is fastened to go across the forehead to hold the covering in its place, and others are attached by which it is fastened beneath the throat. This part of the clothing should be bound and trimmed to match the blanket. These coverings should not be worn in the stable, but only out of doors, when the horse is exposed to cold winds, or when it is standing after having been warmed by work. No stable should be so exposed as to make it necessary to blanket a horse when within it. Stables should be tight and warm, and ventilated in such a manner as not to throw cold drafts upon the horse. Pure fresh air in the stable, although it may be of a low temperature, will so invigorate the circulation of a horse that no protection beyond its own natural covering will be needed, even in the coldest

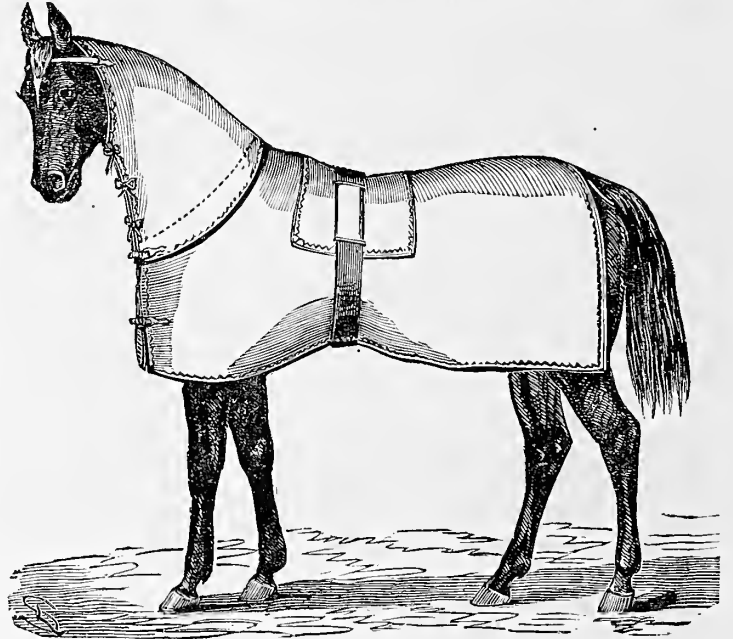

A SUIT OF HORSE CLOTHING.

winter weather. It is when brought out from the still air of the stable into the cutting winds that the animal needs covering, or when a careless driver leaves him steaming, after a brisk drive, standing in a December snow-storm, while he is warming himself before a hot stove.

Hungarian Farm Tools.

In many things the agriculture of Hungary greatly resembles our own, and occasionally we find a useful hint from observing their ways and methods. At the Vienna Exposition of last

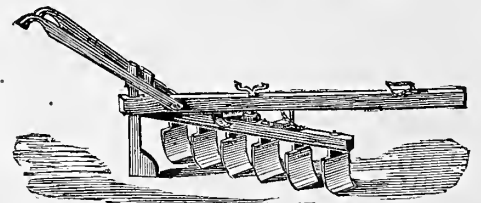

Fig. 1.—HUNGARIAN SEED-COVERER.

year, a large number of Hungarian farm implements were shown, and amongst them, the two which are here illustrated. Figure 1 is a seed coverer for use upon fields that have been sown broadcast. The soil previously plowed, harrowed, and sown, is worked over with this implement, drawn by horses or oxen. Its action is easily understood. The seed is covered, as is

often done by the plow, but much more rapidly. Where drills can be conveniently used, this implement would answer a very good purpose, covering the seed to a more even and certain depth than the harrow, and one stroke being sufficient. Figure 2 shows a roller that has

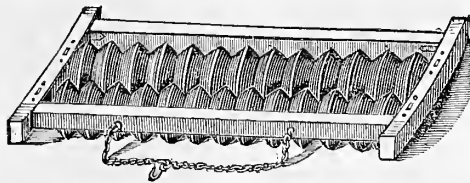

Fig. 2.—HUNGARIAN DOUBLE ROLLER.

several excellent points. It is a double-ridged one, and as the rollers revolve, each of them rubs or grinds upon the other, thus always ensuring clean surfaces. Such a roller as this, made of cement, upon the principle recently illustrated in the *Agriculturist*, (Sept. 1874,) would be a very serviceable implement, both for crushing clods, or rolling newly sown grain fields.

Concrete Houses.

We have, on various occasions, described the method of building houses in concrete, but it seems, from the numerous inquiries we receive, not at sufficient length to give all the information needed. To build a cellar wall or a barn needs but little skill, but to build a dwelling-house, with doorways, windows, cornices, and

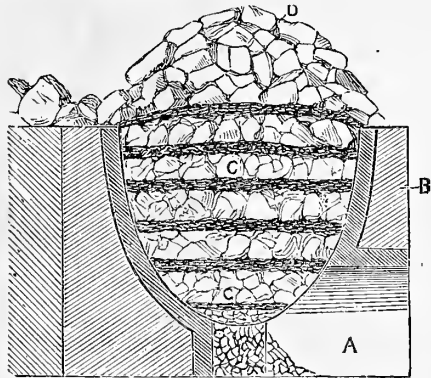

Fig. 1.—A LIME KILN.

other requisites, in which some degree of ornamentation is desirable, needs more skill and more particular instructions. The use of concrete is not advisable where brick or stone of a desirable character can be readily procured; but where these are not available, and the materials for concrete are upon the ground or near by, it is then that it becomes an economical material. The requisites are lime, cement,

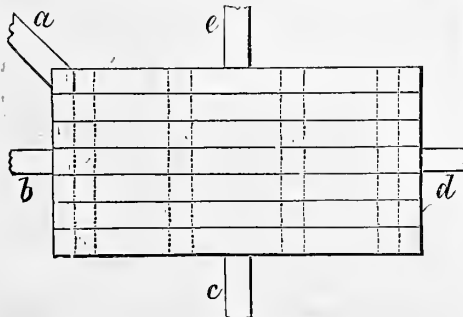

Fig. 2.—MIXING BOARD FOR CONCRETE.

sand, and coarse gravel, or broken stone, broken brick, either new or from old buildings, or slag from furnaces, and coarse ashes. Where lime is not to be procured, the limestone may be burned in a kiln of very easy construction, shown in fig. 1. This is dug out in a bank and

lined with common clay or stone to confine the earth. A stone arch is made in the front, seen at *A*, and the front (*B*) should be supported by a rough stone wall. The limestone is placed in layers with coal, or it may be burned with wood by means of a fire-hole made at the rear of the arch. The lime, with the layers of coal intermingled, is shown at *C*, and at *D* are seen a few large pieces of stone heaped on to the top to retain the heat. When lime is used to make the concrete, it is best to reduce it to powder by grinding in a plaster-mill before it is slaked. Where this is inconvenient, it may be carefully slaked to a dry powder by using water just sufficient to effect this, and no more. It should then be sifted and freed from all unslaked lumps. If this is neglected, the lumps will become slaked after a time by the moisture of the atmosphere, or that in the wall, and in swelling burst and damage the wall. When cement is used, the kind known as the Rosendale will answer as good a purpose as the Portland cement, which is imported and is much dearer. The foundations may be made of lime concrete; it is not necessary to use the more expensive cement in these. The first work is to dig the cellar, or the trench for the foundation. This, if there is no cellar, should be at least three feet deep. The next is to gather upon the spot all the materials for the building in as fully prepared a condition as possible. The mixing boards are then to be made. These should be 12 feet by 7, made of 2-inch plank closely spiked upon cleats, and leading planks should be provided upon which to bring the materials in wheelbarrows. Fig. 2 shows the mixing boards; the plank at *a* leading to the building, the one at *b* to the lime, that at *c* to the gravel, that at *d* to the broken stone, or coarse materials, that at *e* to the sand or fine stuff. These materials should be prepared and heaped around the mixing board, so that they can be conveniently reached. The proper proportions to use are one part of lime to seven of other material, large and small, the coarse and fine being about equally divided. The materials are heaped up as seen at fig. 3, the letters *a*, *b*, *c*, *d*, showing the relative position in the heap of the lime, sand, gravel, and broken stone.

The mixing should be done systematically to ensure success. The heap should be turned over while still dry, by commencing at the middle, as seen at *A*, fig. 4, throwing each half outwards, which will make two heaps, as at *B*;

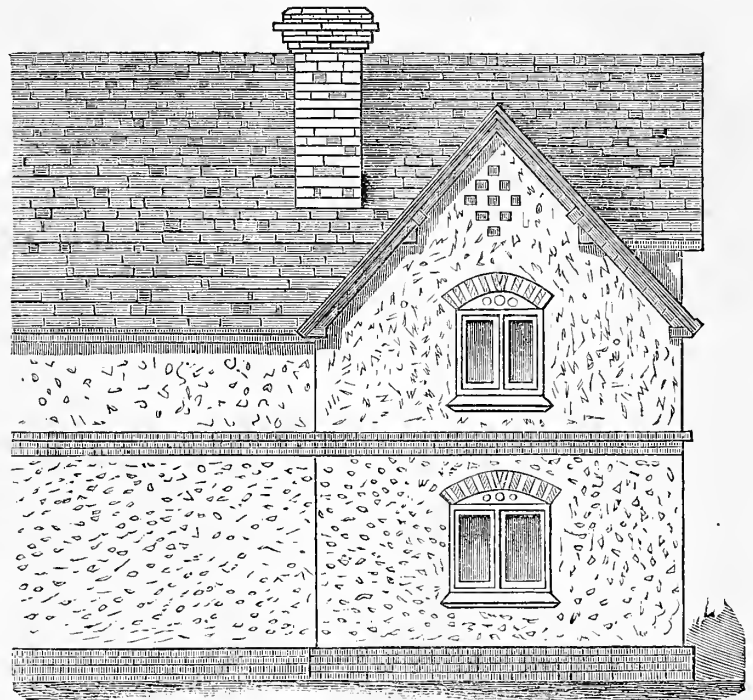

Fig. 13.—CONCRETE COTTAGE WITH BRICK ORNAMENTS.

these are again thrown together in the direction of the arrows seen in the figure, making again one heap as at *C*. Water is now added sparingly, and the heap again divided and brought together as before, until the whole is thoroughly mixed. When cement is used instead of lime, the mixing is to be done in the same manner, excepting that it should be in smaller quantities at one time, and should be used as soon as it is mixed, as it sets or becomes hard very

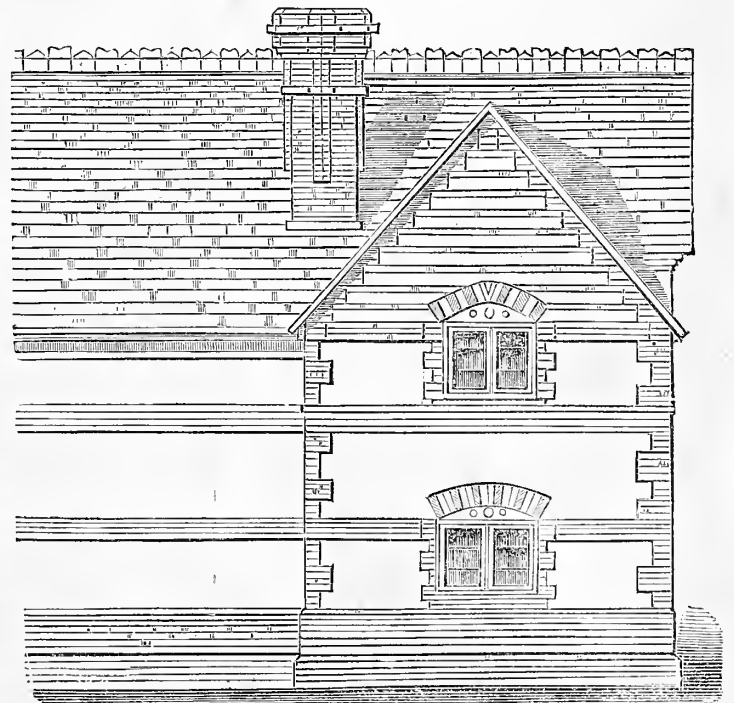

Fig. 15.—CONCRETE COTTAGE WITH BRICK ORNAMENTS.

rapidly. The finer the broken materials are, the stronger will be the concrete when cement is used. At figs. 5, 6 and 7 is seen the method of laying the concrete. Stout wooden posts are set at each angle of the walls, and are kept at an even distance apart by bolts or cross-

pieces of wood, and are stiffened with stays from the ground. Planks with smooth surfaces for each face of the wall are then laid inside of the posts around the whole length of the building, or intended walls. A piece of

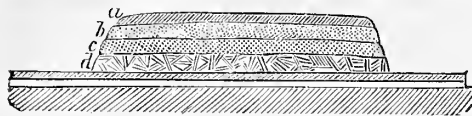

Fig. 3.—THE MIXING HEAP.

iron, shown in fig. 10, is used to prevent the planks from bulging outwards by the pressure of the concrete. These clips are also shown at *a, a*, figs. 5 and 6. The clips, or clamps, are made tight by wedges driven between their ends and the planks, as seen in fig. 9, and at *b, b*, figs. 5 and 6. The walls may be made 9 inches thick or more for the outer ones, and 6 inches for partition walls.

When the trench formed by the planks is filled

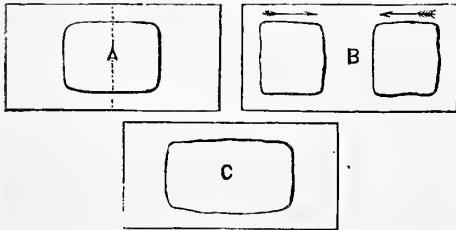

Fig. 4.—MIXING THE HEAP.

up, these are moved up and held to their proper place by means of counter wedges, seen in two different positions at *a, a*, figs. 8 and 9. Fig. 8 is a view looking downwards upon the wall, and fig. 9 looking endwise, showing the planks, *b, b*, and the clip and wedge, *c*; the posts are shown

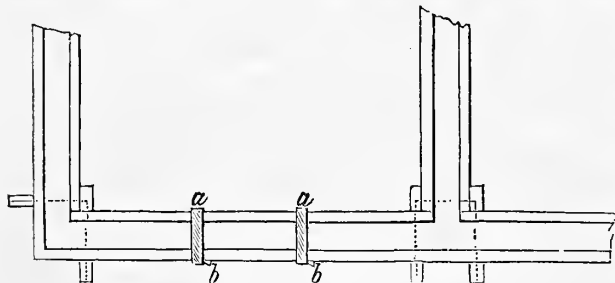

Fig. 5.—ARRANGEMENT OF THE PLANKS.

at *d, d*. The planks should cover the concrete already laid at least 1½ inch, to prevent the fresh laid concrete from being forced out through any crevice. This is shown in fig. 9. In filling up the frame with concrete, it is best to arrange the work of raising the planks, mixing the day's supply of material, filling it in,

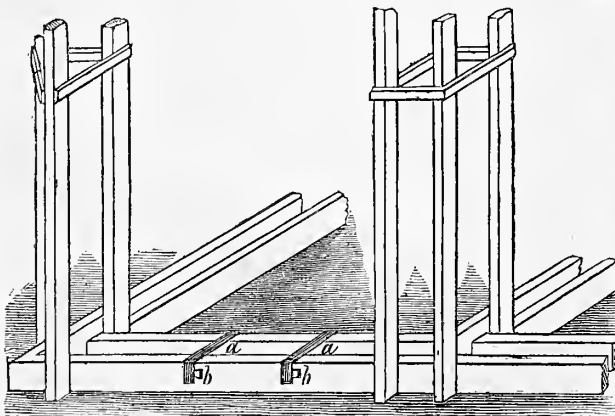

Fig. 6.—ARRANGEMENT OF THE POSTS.

and completing the job, so that all may be done by the close of the day, and the concrete be left undisturbed to dry and harden during the night, leaving everything ready for the

next day's filling. With such arrangements as these, no skilled labor is necessary, but the supervision of any intelligent owner or employer is sufficient, with faithful compliance with the simple directions here pointed out.

No scaffold-poles are needed in this plan: stout brackets may be nailed to the posts to support all needed staging. For the windows, doorways, gables, flues, and fire-places, special arrangements will be required. The door and window-frames should be built in, and a few nails driven through the frames, or a few cleats fastened thereto, will be sufficient to hold them firmly in their place. The joists are to be built into the walls, and a few spikes driven in the ends, or a cleat nailed to the upper part of each end, will

serve to hold them to the walls. This is shown in fig. 11. For fire-places wooden arches must be provided, and for the flues wooden cores, or molds, slightly tapering, so that they can be raised along with the wall, will be needed. If the wall is desired to be furred for lathing, pieces of wood should be built in the wall in the proper places. But this is a needless expense, as the concrete, being porous and a poor conductor of heat, no moisture gathers upon the inner surface of the wall by condensation in cold weather, the finishing coat of plastering may therefore be laid directly upon the wall. The writer has

lived for a year in a lime-concrete house in a cold northern climate, where brick-houses are always damp inside by reason of the constant condensation of moisture upon the walls in the winter, unless they are furred, but never discovered the least tendency towards dampness. This is one of the advantages of concrete houses, and not a slight one. One of the chief objections to concrete buildings, is their usual flatness, squareness,

and severely plain, not to say unsightly appearance. The walls are usually mere slabs set upon end, and pierced with square holes for windows and doors. Recently, however, the greatly enlarged use of concrete as a building material in England, has led to many improvements in the style and finish of this class of houses, and architects have turned their attention in this direction. Mr. George Hunt, architect and surveyor to the Royal Agricultural Society of England, has designed some plans for the ornamentation of concrete houses, which have been published in the Society's Journal, and which we gladly reproduce as suggestions, if not for models for our readers. The simplest improvement consists in using the finest broken materials for the face of the work, and backing that up with the coarser stuff. This gives a better finish. Then a brick or stone plinth may be put around the building, or a mold may be made by which moldings may be run around the base, with bases colored by the addition of some cheap earths. Brick arches, or colored blocks of

concrete, may be built around the doors and windows, with plain or chamfered edges, or these portions of the building may be stained

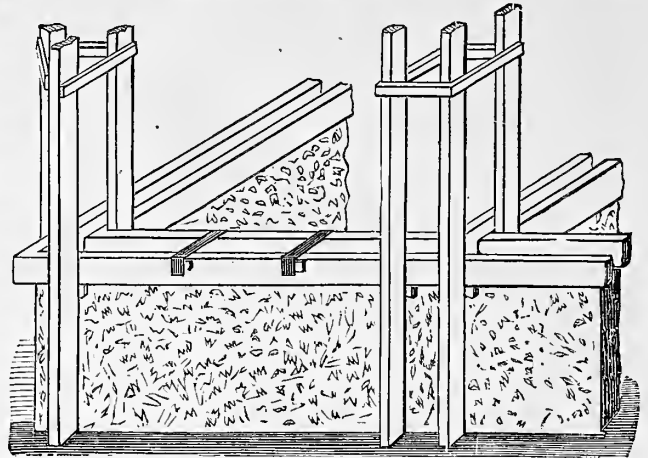
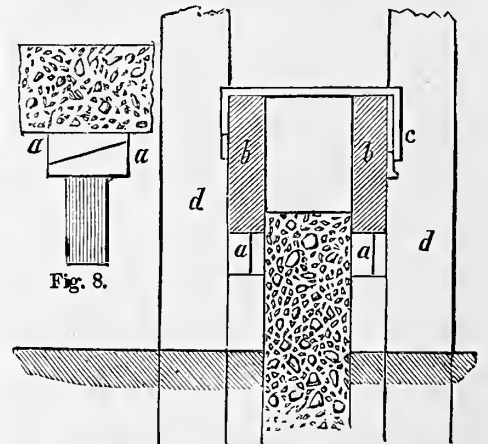

Fig. 7.—LAYING THE CONCRETE.

of some suitable color, or a somewhat different make of concrete of finer material, might be used for these portions. A great variety of new ideas will spring up from these hints and suggestions. Figures 12, 13, 14, and 15, illus-



Figs. 8 and 9.—RAISING THE PLANKS.

trate these details sufficiently to give a clear idea of them, as well as a good basis from which to greatly enlarge these ideas. In fig. 12 the "plinths" of brick or concrete are shown at *a* and *b*. At *c, d*, are shown details of "strings" in section; at *e*, the "string" *d*, is shown in perspective, and at *f* is seen a plan for window or doorway with head and jambs.

The elevation of the building finished in this style, is seen at fig. 13. The rafter-feet project a few inches, and a board of 9 inches in width, projects around the gables. Fig. 14 shows a more ornamental design. At *a* is the base which reaches to the lower floor window sills,

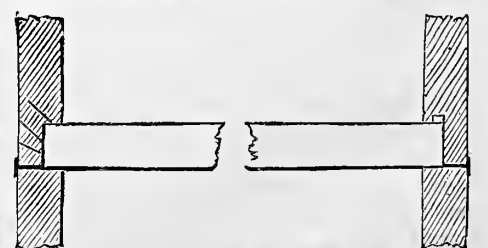

Fig. 11.—FASTENING THE JOISTS.

(as seen also in fig. 15), at *b* is the cornice, of brick work wholly or in part, with gutter.

At *c*, a cornice is shown with alternate bands of concrete and brick, or concrete of different colors. At *d* and *e* are seen plans of chimney stacks, that at *d* belonging to the elevation shown at fig. 13. The remainder of these details belong to the elevation shown at fig. 15. The crest of this roof is intended to be made of ornamental tiles. There is nothing in these plans but what are real, there are no shams or deceptive appearances which fail in use, and if

Legislation in Reference to Dogs.

Our correspondent, W. W. W., of Griffin, Ga., is interested in sheep culture, and wants to know what States have passed laws against dogs, and the proper requirements of a dog law.—We sent his letter to our friend "Connecticut," who returns the following as to the

DOG LAW OF CONNECTICUT.—The following statute was passed by the Legislature of Connecticut in 1867, and is still in force:

SEC. 1ST.—It shall be the duty of the Assessors of the several towns of this State, to cause all dogs, three months old and upwards, which have not been registered according to law previous to the first meeting of the board of assessors, to be entered upon the assessment list of persons owning such dogs; and such dogs shall be presumed to be owned by the keeper or occupier of the premises, where such dogs are kept.

SEC. 2ND.—The owner or owners of all dogs not registered as aforesaid, shall pay an annual tax into the treasury of the town where such dogs are kept, to be levied and collected with, and in the same manner as the ordinary town taxes, of three dollars for every male dog, and six dollars for every female dog.

Another act passed at the same session of the Legislature—provides that any excess of money in the dog-fund may be used for ordinary town expenses after all damages done to sheep in previous years are paid for.

In the general statutes of this State in section 113, it is provided that any two Justices of the Peace may make such rules and regulations against dogs as they think the safety of persons and property demand.

SEC. 114 provides that the inhabitants of the several towns in legal meeting assembled, may make necessary regulations and offer bounty for the killing of dogs.

SEC. 115 requires the owner of a dog over three months' old to register and number such dog in the Town Clerk's Office on or before Sept. 1st in each year, and to pay fifteen cents for registering.

SEC. 116 provides that he shall pay into the treasury two dollars for every male dog, five for every female so registered, and that he shall put

a collar upon his registered dog, with his name upon it and the number of the dog; and any person killing said dog shall be liable for his value. But any one may kill a dog found worrying sheep, whether registered or not.

SEC. 117 provides that the Town Clerk shall pay all monies, received for the privilege of keeping dogs, into the treasury.—**SEC. 118.**—

The Selectmen are to post notices in every school district, that dog owners must either kill their dogs, or cause them to be registered.

SEC. 119 inflicts fifty dollars fine upon the Selectmen who refuse to post such notices.

SEC. 120 fines whoever puts a false register upon his dog's collar seven dollars.

SEC. 121 makes it the duty of the first constable to prosecute all violation of the dog laws.

SEC. 122.—Those who suffer damage in their flocks by death or maiming from dogs, are to give information of the fact to one of the Selectmen of the town, who are to estimate the damage, and pay it from the dog fund, unless the owner of the dog can be made to pay.

These laws, of which we have given the outline, work well in Connecticut, and encourage sheep raising. They keep the dogs in check and make it easy for sheep owners to recover damage done to flocks where any is suffered. It is our impression that dog laws have been passed in most of the older Northern States, and that they are most stringent in New York and New England, where wool and mutton are most valuable. It is exceedingly desirable that we should have similar legislation in all the States, and that sheep husbandry should be made so safe and profitable, that we have no occasion to import wool. The census of 1870 reported 28 millions of sheep in the country, and 100 millions of pounds of wool as the annual product. And yet we import large quantities of wool and woolen goods that we ought to produce on our own farms and in our own factories. We are glad to believe that we are increasing our consumption of lamb and mutton. Give us stringent dog laws in all the States, and we might make these the cheapest of all the meats in the market. **CONNECTICUT.**

FOREIGN STOCK SALES.—At the recent sales of the Duke of Devonshire's Shorthorns, the average price realized for 28 cows and heifers, and 15 bulls, was about \$1,970 each. The highest prices obtained were for two cows, \$5,250 and \$5,775. At the Earl of Bective's sale, which followed this, 43 animals brought an average of \$1,920. The animals sold at these sales were by no means the best of the herds, these being reserved. At a sale of Shorthorns belonging to Mr. Cheney, and R. Parvin Davis, occurring soon after the above, the 8th Duchess of Airdrie brought \$8,927, and a yearling heifer, the Duchess of Gloucester, \$9,373. Both of these were American bred animals. The average of Mr. Cheney's sale was \$2,095 each, for cows, bulls, and calves; and that of Mr. Davis' sale was \$1,250 each; the latter sale was of all English bred animals. At a sale of fine Hereford cattle, belonging to J. B. Green, of Knighton, a lot of 108 cows and heifers sold for an average of \$222. One cow brought \$650, and one heifer calf \$400. The average of 14 bulls was \$205. A large number of this herd were descended from a cow which lived and bred up to an age of 26 years. At a sale of black polled cattle in Scotland, 23 cows brought an average of \$216 each. A fine bull brought \$500; bull calves sold for \$80 to \$300, and heifer calves for \$50 to \$180. The disparity between these latter unfashionable and the former fashionable stock, does not rest upon a difference in intrinsic excellence by any means, and when we know that three Herefords can be kept where two Shorthorns can, and that the herd referred to here, was bred and fed upon the top of a Welsh mountain, the Herefords may be regarded as the more profitable cattle.

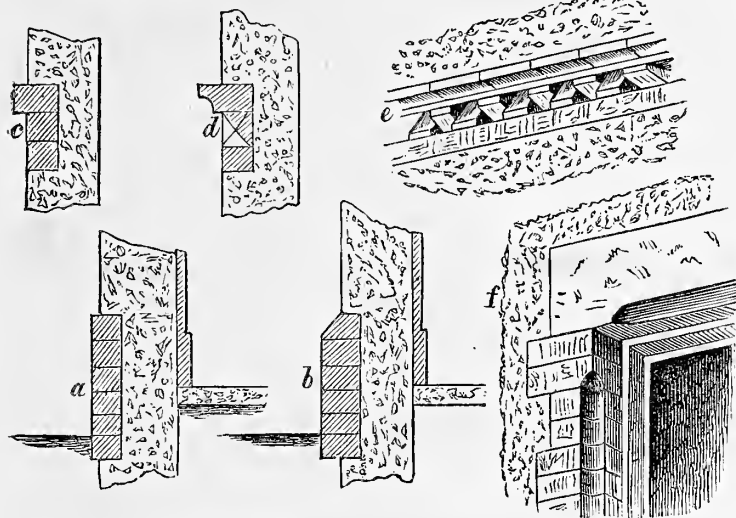

Fig. 12.—ORNAMENTS FOR BUILDING.

there is some want of elegance in the style, there is neatness, solidity, and reality, which, with the economy of the plan, render it very desirable where cheapness and durability are essential. The plans here given, are intended to apply to the building of the class of houses described and illustrated in the *American Agriculturist*, of July, 1873, page 252; although it is adapted equally well to construction of much larger and more costly houses, as well as stables, barns, and outhouses.

The cost of concrete buildings upon this plan, is less than half the cost of brick, including the cost of the plank, etc., for the molds, one outfit of which will answer for a great

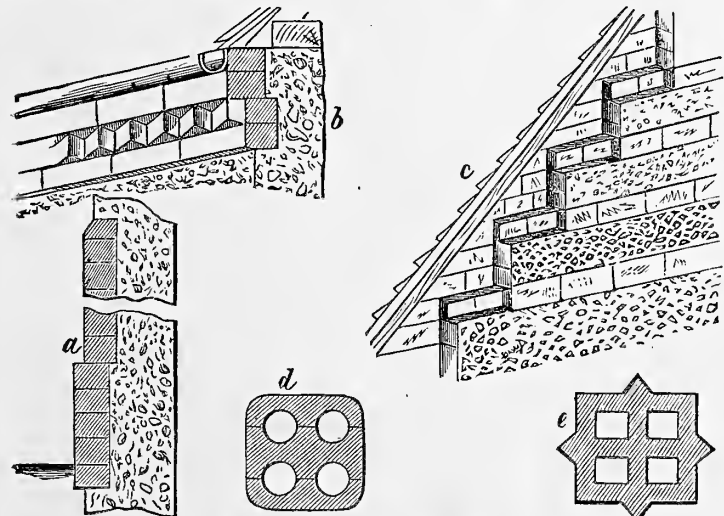

Fig. 14.—ORNAMENTS FOR BUILDING.

many buildings. We know of no plan more suitable than this for the use of village building associations, where a number of houses of a similar size are needed, or for farm houses, which in some districts are built very much after the same pattern. In these cases the saving in cost will be greater in proportion to the number of houses built of the same kind of materials.

Horticulture at the International Exhibition of 1876.

The Horticultural Hall, of which we print an illustration this month, is one of the five principal buildings which the United States Centennial Commission will erect for the accommodation of the International Exhibition of 1876, at Philadelphia. These structures—the Industrial Hall, or main exhibition building, the Machinery Hall, the Horticultural Hall, the Agricultural Hall, and the Art Gallery—will have an aggregate floor-space of about 40 acres; but the Industrial and Machinery Halls have been so designed that they can be enlarged to almost double the capacity originally allowed, should the demands for space require it. The Horticultural Hall has been designed by Mr. H. J. Schwarzmann, under the supervision of the National Horticultural Society. Its materials are glass and iron, its length 310 feet by 160 in width, giving an area of one and a

and the Cold Houses, and at the ends, on the right and left of the entrances, the dining-halls, offices, retiring-rooms, etc. In close proximity to the Horticultural Hall will be a number of subsidiary structures—a Victoria Regia House, Domestic and Tropical Orchard Houses, a

see side by side the full variety of the forest products and fruits of the country, from the firs of the extreme North to the oranges and bananas of Florida, and grapes and other fruits of California. An impression will thus be produced of the fertility of the land, and of the

vast range and diversity of its products, of which few persons have any conception; and the exhibition must be one which, at least in this country, will be without a parallel for extent and completeness. In addition to the strict horticultural display, careful provision will be made in advance for trials of agricultural machinery. At the disposal of the Centennial Commission are 450 acres of land, within the limits of Fairmount Park; and a considerable portion of this, divided into lots of suitable size, will

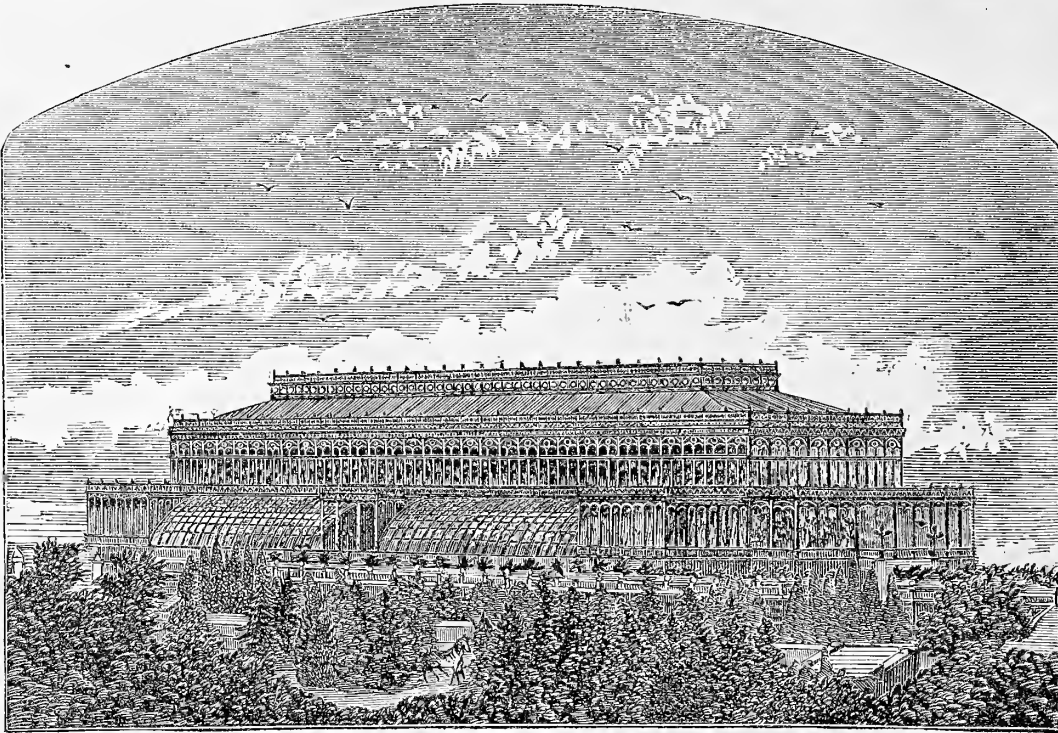

THE HORTICULTURAL HALL AT THE CENTENNIAL EXHIBITION.

Grapery, and other horticultural structures. The surrounding grounds, including a large tract, which may be extended almost *ad libitum*, will be arranged for out-door planting, which will constitute the larger portion of the horti-

be put into crops, for the purpose of testing the mowers and reapers and other agricultural implements offered for competition. About a year ago a National Horticultural Society was organized for the express purpose of co-operat-

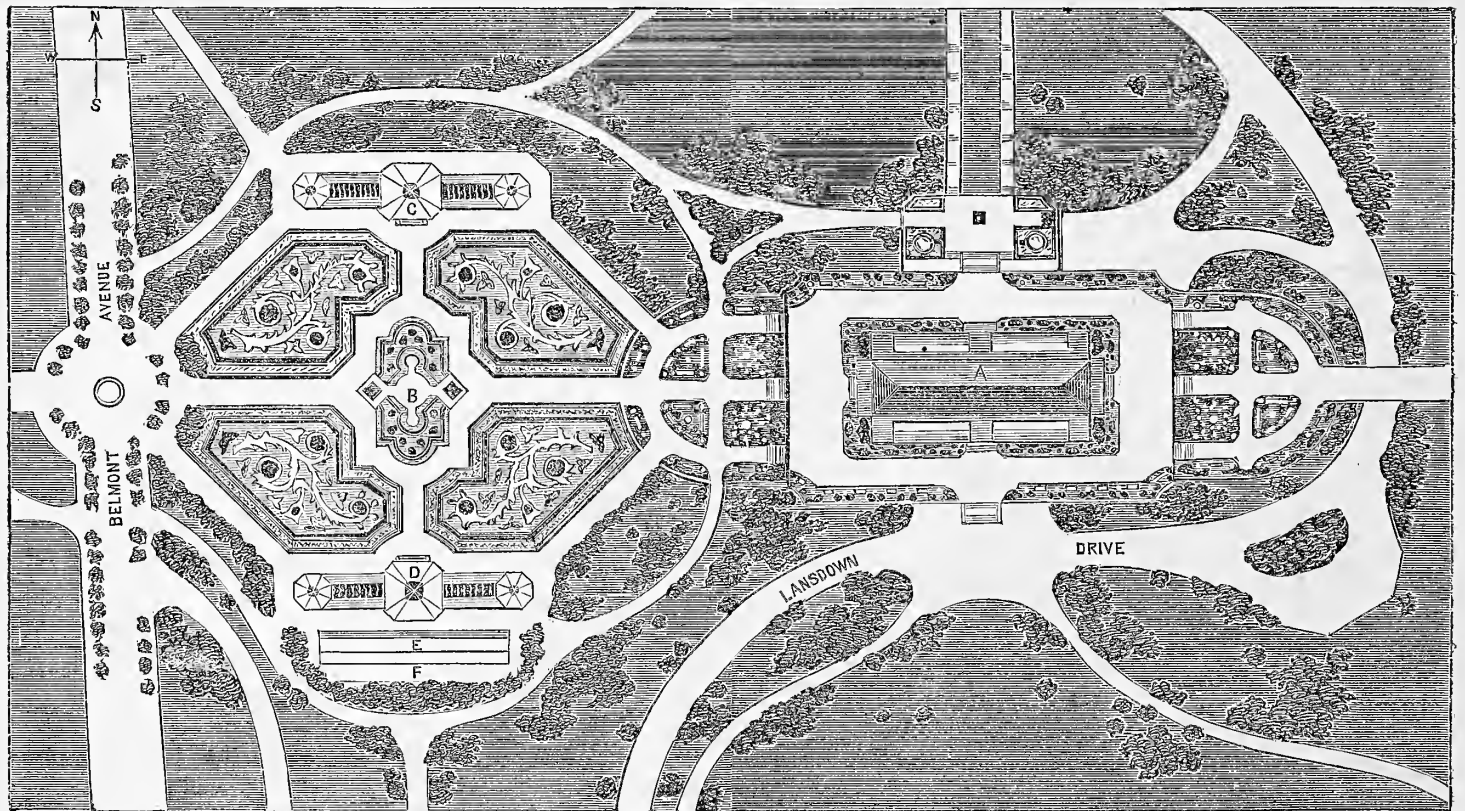

PLAN OF THE HORTICULTURAL GROUNDS.—A, Conservatory; B, Victoria Regia House; C, Domestic Orchard do.; D, Tropical do.; E, Grapery; F, Hot-Beds.

quarter acre. The greater portion of this space is devoted to the Grand Conservatory, which is 227 by 77 feet, and occupies the central portion of the building; there being between it and the outer walls on either side, the Warm

cultural display. We give an illustration of the plan of these grounds. It is purposed to plant, at least a year before the opening of the exhibition, the representative trees of all parts of this Continent. The visitor, it is intended, shall

ing with the Centennial Commission, and its various committees are composed of some of our most active amateur and professional horticulturists. The matter is in good hands, and we may hope to see a fine exhibition in 1876.

Plants Received by Mail.—How to Treat.

A correspondent, "J. H. M.," Coldwater, Mich., writes: "I am a constant reader of the

tings, instead of watering them daily, as when they are growing vigorously, they are not watered for eight or ten days, and then sparingly, until a growth of leaves and shoots appears. If the plants are injured by drying out or by

where its stems may hang over rocks, or trail over banks. There is a white-flowered variety, which is much more rare than the ordinary kind, probably for the reason that it does not produce seed so freely. This pea is an excel-

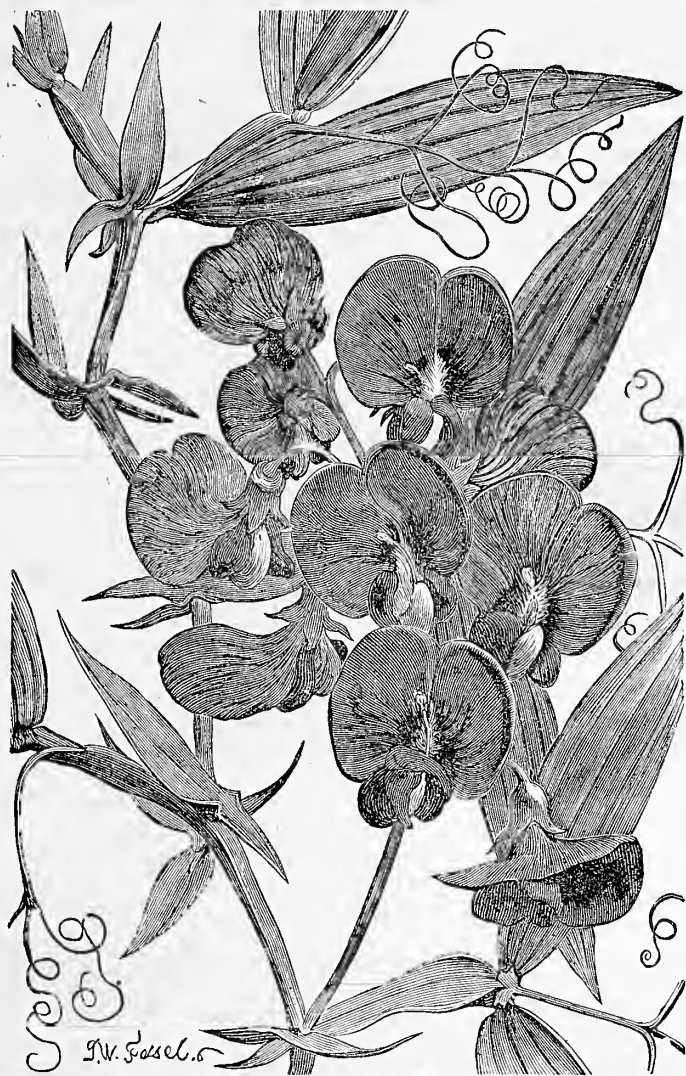

THE EVERLASTING PEA—(*Lathyrus latifolius*.)



NEW WHITE PANSY—"WHITE TREASURE."

Agriculturist, and wish to inquire how plants should be treated when received by mail."

Plants received by mail, or even by express, are in the majority of cases killed after their arrival by what is believed to be kindness. As they have usually been on a long journey, they are supposed to be hungry, and are at once over-supplied with food, a kindness they have no way of resisting, and can only manifest their opinion of it by sickening or dying outright. This mistaken hospitality is usually manifested in placing the weak and bruised roots in a flower-pot several times too large for them, and deluging the soil in which they are planted by water. This is the general treatment. The proper one for plants received from a distance, particularly if by mail, (when the soil is usually shaken from the root,) is to place them in a pot only large enough to admit the smallest possible portion of soil between the roots and the sides of the pot, then keep them rather dry than otherwise, until signs of new growth begin. Always bear in mind that when the roots or leaves of a plant have been bruised or detached, the vitality of the plant has been lessened, and it requires less food in consequence, and has no need of it until the roots and leaves are in vigor again. When from any cause a plant drops its leaves, hold on the water until it again starts into growth. When the florists cut down their plants for cut-

heating, as sometimes happens, cut the tops back severely, to induce new buds to push.

The Everlasting Pea.

While most persons are well acquainted with the Sweet Pea, a charmingly fragrant and variously colored garden annual, but few seem to know its perennial brother, the so-called Everlasting Pea. Neither the Sweet nor the Everlasting Pea belong to the same genus with our common garden pea, (*Pisum*), but they are, more properly speaking, Vetchlings, (*Lathyrus*), though the difference between the two depends upon points which would only be noticed by a botanist. The best known perennial pea is *Lathyrus latifolius*, a native of Europe; the stems are 6 feet or more long, and broadly winged; the leaves consist of a pair of oval or lanceolate, strongly-veined leaflets, terminated by a branching tendril; the flowers are on stalks longer than the leaves, several in a cluster, large and showy, of a lively purplish-rose color. The plant flowers very freely, being in bloom nearly all summer. If planted where it has room to spread, a single specimen, growing flat upon the ground, is a handsome object; or it may be allowed to run upon a low trellis, or even over brush, and it may be introduced with good effect in a wild part of the grounds

lent plant for cut-flowers for summer bouquets, and is worth growing for that purpose alone. A related species, *L. grandiflorus*, has larger flowers, but only two or three in a cluster. The seeds of the everlasting pea may be sowed in spring, or if they can be obtained early in the fall, and then sown, they will before winter make plants large enough to flower the next year. Well established plants may be multiplied by dividing the roots.

A New White Pansy—"White Treasure."

Among all the varied colors presented by pansies it is not strange that there should be white ones; indeed there are several old named sorts of this color—or rather lack of color, but there are not so many that a new and meretricious white variety is not welcome. "White Treasure" originated with M. J. W. Morris, a florist at Utica, N. Y., who sometime ago sent us specimens of the flowers, and more recently we have been able to inspect entire plants. The strong stocky habit of the plant is its most striking characteristic; it is very short-jointed and large stemmed without the straggling weakness that often makes these plants unsightly; the foliage is of good substance and dense, and stands the sun well; a photograph taken of the bed in August shows a vigor of growth quite

unusual with pansies in hot months. The flowers are well up above the leaves, upon strong stems, and of good shape and texture, perfectly white except a small orange-colored eye. The fringe at the base of the side petals is pure white, and by its different texture from the petals themselves, increases the beauty of the flowers. The flowers from which the drawing was made, were quite an inch and three-fourths across. This variety comes true from seed, which the plant produces freely. Almost every grower of flowers is fond of pansies, and will regard a fine white one with favor, and it will no doubt be a valuable pansy for forcing. After examining specimens of the plant, Messrs. Peter Henderson & Co. secured the whole stock of the seeds of this novelty.

More New Grapes.

For several years there has been but little excitement about new grapes; but this season there are several new ones offered, and we know of still others that are being thoroughly tested before placing them before the public.

THE LADY

is the name of a new white grape, offered by Mr. George W. Campbell, of Delaware, Ohio. We have had an opportunity to test the fruit, and were much pleased with its quality. It is so much better than the Martha that it must entirely supersede that variety; indeed, to those not very critical in their judgment of grapes, this would rank among the best. Mr. C. has been careful to test this variety for five years before bringing it out, and, knowing his long experience with grapes and his caution in forming an opinion, we are quite willing to accept the following, which he writes in a private note: "It has been perfectly healthy, both in vine and fruit. It endured the winter of 1872 and 1873, when the thermometer fell to 32° below zero, uninjured and wholly unprotected, being apparently the hardiest vine I ever had. * * * It ripens earlier than the Hartford, Ives, or any other popular early grape." The Lady is a seedling of the Concord, and ripens two weeks before its parent—and two weeks in the ripening, in many localities, decides between grapes and no grapes. Mr. C. says that upon the old vines the bunch and berry equal those of the Concord in size. The sample sent us was somewhat smaller; color, a pleasing light yellowish green, with a bloom, the berries hanging well to the cluster. Mr. C. states, that it keeps better after being picked, and that the skin, though thin, is more tenacious than that of the Concord, and the fruit consequently bears handling better. The popular taste prefers white grapes, and people will pay a much higher price for a white variety than for dark colored ones of much better quality. Should this, as a white grape, prove the equal of the Concord, as a black variety, Mr. Campbell will be entitled to the thanks of fruit growers for introducing it.

THE BRIDGETON,

is a new variety, offered by Messrs. Chase Brothers & Woodward, of Rochester, N. Y. It is a handsome black variety, grown from the seed of Concord, crossed with Diana Hamburg. These gentlemen say: "It appears to combine the hardiness and rapidity of growth, and vitality of the Concord, with the superior quality and beauty of Diana Hamburg. Having thick, large foliage, it is enabled to withstand the heat of summer, and to escape

mildew, being in perfect health at the close of the growing season, it exhibits extreme hardiness, and successfully endures the cold." The fruit, to judge from the specimen sent us, is one of excellent quality, and we hope to be able to give a report hereafter from personal experience with the vine.

THE WHITEHALL

would seem a misnomer for a black grape, did we not know that it was so called because it originated at Whitehall, N. Y. This is put before the public by Merrell & Coleman, Nurserymen, Geneva, N. Y., who claim for it great earliness, with vigor and hardiness. It ripens at Geneva, from August 20th, to September 1st. The fruit, which has the general appearance of the Isabella, is quite distinct in quality, and has a flavor which has been likened to that of an ox-heart cherry. The bunch sent us impressed us favorably with its merits; a portion of the cluster was left in the box in which it came, and at the time at which we write—the first week in November—the grapes, though shrivelled, show no signs of decay, and are still eatable, which indicates that the Whitehall promises to be a good keeper.

Unhealthy Plants—The Remedy.

BY PETER HENDERSON.

Whenever plants begin to drop their leaves, it is certain that their health has been injured either by over-potting, over-watering, overheating, by too much cold, or by applying such stimulants as guano, or by some other means having destroyed the fine rootlets by which the plant feeds, and induced disease that may lead to death. The case is not usually important enough to call in a "plant doctor," so the amateur begins to treat the patient, and the practice is in all probability not unlike that of many of our household physicians who apply a remedy that increases the disease. Having already destroyed the, so to speak, nutritive organs of the plant, the stomach is gorged with food by applying water, or with medicine, by applying guano or some patent "plant food." Now the remedy is nearly akin to what is a good one when the animal digestion is deranged—give it no more food until it re-acts. We must then, if the roots of the plant have been injured from any of the above named causes, let the soil in which it is potted become nearly dry; then remove the plant from the pot, take the ball of soil in which the roots have been enveloped, and crush it between the hands just enough to allow all the sour outer crust of the ball of earth to be shaken off; then re-pot in rather dry soil (composed of any fresh soil mixed with equal bulk of leaf-mold or street sweepings), using a new flower-pot, or having thoroughly washed the old one, so that the moisture can freely evaporate through the pores. Be careful not to over-feed the sick plant. Let the pot be only large enough to admit of not more than an inch of soil between the pot and ball of roots. After re-potting, give it water enough to settle the soil, and do not apply any more until the plant has begun to grow, unless indeed the atmosphere is so dry that the moisture has entirely evaporated from the soil, then of course water must be given, or the patient may die from the opposite cause—starvation. The danger to be avoided is in all probability that which brought on the sickness, namely: saturation of the soil by too much water. Other causes may induce sick-

ness to plants, such as an escape of gas in the apartment, or smoke from a flue in the greenhouse, but in all cases, when the leaves fall from a plant, withhold water, and if there is reason to believe that the soil has been poisoned by gas, or soddened with moisture, shake it from the roots as before advised, and re-pot in a fresh flower-pot. Many years ago, when I used smoke-flues in my greenhouses, some kindling wood, carelessly thrown on the top of one of them, ignited, and the smoke caused the leaves of every plant to drop. There were some 3,000 plants, mostly Tea-Roses, in the greenhouse; it would have been too much of a job to re-pot all, but by withholding water for some ten days, until they started a new growth again, very few plants were injured.

Preserving Flowers—Winter Bouquets.

In former articles were described the methods of preserving flowers by fumigating with sulphur and by drying in sand, and it was advised to simply dry the "everlasting" flowers and grasses for future use. To our own taste a bouquet of everlasting flowers, made up in their natural colors, just as they were dried, is a pleasing object, and so is a bouquet of grasses that have been dried in the shade, and which are more to be admired for their grace of form than for their color, although this presents a considerable variety in different shades of green and straw color, according to the age of grasses at the time of collecting them, and the care with which they were dried. Yet many persons are not content with these simple things in their natural state; everlasting flowers with staring colors not their own, and grasses of every hue from bright yellow to black (!) are imported and sold, and persons who have seen these wish to imitate them. Of course tastes differ. Ours is to have bouquets as natural as possible; others wish them quite unlike anything that nature ever made. We do not assert that we are right and others are wrong, but we can assure those who are content to take the everlastings and grasses just as they grow, will save themselves a great deal of trouble. We have had numerous inquiries about

CRYSTALLIZING GRASSES,

and this is perhaps one of the simplest methods of treating them, as they are not given unnatural colors, and if properly done, resemble something in nature; almost every winter we have one or two mornings, when every tree-twig, and every bit of dead grass is hung with ice-crystals, and is resplendent in the rising sun. This effect can be very well imitated by depositing crystals of alum upon the dried grasses. A year or so ago, one of those persons who write upon all possible subjects, and get their articles published in papers which know no better, gave directions for crystalizing grasses which must have disappointed every one who tried it. It was to make a solution of alum in boiling water in a stone jar, and suspend the grasses *above* the solution! Nothing could be more thoroughly absurd than this; the writer could as well expect to satisfy hunger by looking in at the window of a restaurant, as to get alum crystals on grasses in this way. Here was a physical impossibility gravely written out for the guidance of other people. Much of the hack writing for papers is after this style. To deposit alum upon grasses, or to crystallize them as it is called, one should know the principles upon which the operation depends, in order to be able to modify it to meet

different circumstances. One part of alum takes about fifteen parts of cold water to dissolve it—or in a rough way we may say that a pint of cold water will dissolve an ounce of alum—if more alum be added, it will remain undissolved, the water at that temperature can dissolve no more—it is saturated. If we heat the water, its ability to dissolve alum is much increased, and if boiling it will dissolve more than its own weight of alum; the pint of water which when cold could only dissolve a little over an ounce, when boiling will take up over a pound of alum. If this pint, which dissolved a pound of alum, be allowed to cool, the alum will be gradually deposited, until at length there will only remain the ounce it is capable of dissolving when cold. If a strong solution of this kind is cooled, the excess of alum will be deposited rapidly, and in a confused mass, but if we make a hot solution, with only a little more alum than the water will hold when cold, the excess will be deposited slowly, in well-defined crystals, and if a rough substance, like grass, or a bit of string, be placed in the liquid, the crystals will collect upon that in preference to the smooth surface of the glass or stone jar. Then, to have the grasses studded with clear, bright crystals, with well-defined edges, we must use a comparatively weak solution, and allow the deposition to go on slowly. In practice we prefer a solution in the proportion of two ounces of alum to the pint of water, or a pound to the gallon, which is as small a quantity as will cover any considerable bunch of grass. A wide-mouthed stone-jar is the most convenient vessel, and its size and the quantity of liquid must be proportioned to the quantity of grasses to be treated. Tie the grasses in small bunches, and arrange to hang them to sticks laid across the mouth of the jar. Put into the jar a pound of alum, broken fine, and pour over it a gallon of boiling water; stir with a clean stick until dissolved, which will be very soon, and then suspend the grasses in the liquid, and set away where it will not be disturbed. When the liquid is quite cold there may be no appearance of crystals upon the grasses—never mind, wait. The deposit will commence in ten or twelve hours, it may be later, much depends upon the temperature of the room. The beginning will be slow, but all the better, for the brighter will be the crystals. When the grass has a sufficient covering, remove and hang up to drain and dry; slender grasses should have less deposited on them, than stiff ones, as the effect is injured if they appear too heavy. One trial will be worth any amount of description, and if it appears desirable to hasten the process, use a larger proportion of alum.

DYEING GRASSES.

For most colors it is necessary to bleach the grasses, especially if they are decidedly green. To do this, take two teaspoonfuls of bleaching powder, the Chloride of Lime, as it is called in the shops. Wet it and rub out the lumps with a smooth stick, then add water to make a quart. Then add two or three tablespoonfuls of vinegar—it is not possible to be definite, as both the lime and vinegar vary so in strength, but add enough to make the liquid smell distinctly of chlorine; let it stand, and pour off the clear liquid from the sediment, and if any lime floats, it will be necessary to strain the liquid through a cloth. Use glass or earthen ware. Immerse in this the grasses until white, or nearly so; some will not bleach at all, others will do so in a few minutes when they cease to lose color

remove, rinse, and hang in the sun to dry. The colors used for dyeing them are the same as those for

DYEING EVERLASTING FLOWERS.

Ammobium, White Acroclinium, and some few other cultivated everlastings, are already white, as is our native Pearly Everlasting, (see page 381, October last), which is one of the best. With the colored ones, such as the French *immortelles*, some may be dyed as they are, while others must have their natural yellow color removed. This is done by a solution of white castile soap, an ounce and a half shaved fine, and dissolved in a quart of hot water. The flowers are placed in this for a short time, and then rinsed in cold water, repeating the operation if necessary, until they are white. The white flowers may be made to take any desired color, while the others may have their tints brightened or changed by the use of acids and other agents. The white flowers and the bleached grasses, may be dyed with the ordinary materials used for domestic dyeing, such as Brazil wood, with the colors changed by the use of lime, lye, alum, and other mordants, but any result obtained from these ordinary dyes, will be quite unsatisfactory, and as compared with the imported flowers and grasses, be quite lacking in brilliancy; the reason for the superiority of the foreign articles, is that they are treated with aniline dyes, which give a purity and brightness of color, not attainable by any other method. We advise those who wish to experiment with dyeing these things, not to be at the trouble unless they can procure these aniline dyes. The use of these in the pure form, which is usually that of crystals, is troublesome, but they are now put up of all colors by several parties, in both the state of liquid and powder, and sold by druggists for domestic dyeing. All that is required, is to mix the liquid or powder, as the case may be, with hot water, and soak the flowers or bleached grasses in the liquid until sufficiently colored. The dyes put up in this manner, have full directions for their use, and these may be followed, using the white flowers instead of silks or other fabrics there mentioned. A further consideration of this matter must be postponed to another month.

Mr. Ricketts' Hybrid Grapes.

NOTES BY F. R. ELLIOTT.

[A gentleman at Newburgh, N. Y., Mr. J. H. Ricketts, has long been quietly at work in hybridizing our native grapes with the European, and has met with greater success than has attended the efforts of the many others, who have experimented in the same direction. Mr. R. has occasionally exhibited some of his new varieties, and we have had occasion to test the high quality of a number of them. This fall we had an invitation from Mr. R. to visit and examine his grapes, but were unable to accept it. Knowing that Mr. Elliott was intending to inspect the vines, we requested him to give us notes of the more prominent varieties, which are here appended. These notes have a special interest for grape growers, from the fact that it is probable that a number of the choicest of these new varieties will soon be placed in the trade. The notes are irregular, being taken as the vines stand in the rows; those of no special promise being omitted.—ED.]

No. 12, B.—Is a round oval black berry, with a blue bloom, and a large bunch, shouldered; its flesh is rich and delicious, without pulp.

No. 24.—Is a small grape, about size of Elsinburgh; black, and may be valued for wine, but too small for market.

No. 22.—Is a large, greenish-white berry; a very large and long bunch; sweet and vinous in quality; but here does not ripen earlier than Isabella. The leaf is thick and large, as well as the wood, and in localities like Cincinnati, or the Missonri vine regions, it must, when introduced, take precedence of all.

No. 72.—Is a medium-sized berry, black, nearly round; very sweet and rich. The leaf is large and thick.

Don Juan.—This is one that the grower has felt should be named, and accordingly he has attached the *Don Juan* to it. I have my doubts of its value equaling some of his others. The berry is about size of Rogers' 15; similar, but deeper in color; is without hard pulp vinous, sparkling, sweet.

No. 1.—Is a black grape, oval-shape, large long bunch; flesh firm, juicy, and sweet; a thick, firm, skin, but not harsh to the taste. The growth of leaf and wood strong.

Clinton, No. 6.—Is a small black grape, much resembling Clinton, which is one of its parents; but it is early in ripening, and very sweet.

No. 207, C.—A peculiar rosy-yellowish color; round in form, with a certain flavor and perfume of the pine apple. It is a strong grower, and to an amateur, will, if ever propagated, be one that he must and will have in his grounds.

No. 12.—Is an oval, black berry, of above medium size; a loose bunch and not large, but the flesh is very sweet and rich.

No. 13.—A whitish-green grape, of medium size; a long bunch; very rich and sweet in its flesh; really one of the best in quality of its color.

No. 14.—This is a peculiar large greenish-white grape, equal to "White Tokay," which is one of its parents. The bunch is very large and shouldered; leaf thick and strong, and so is the wood.

Quassaick.—This is another of those Mr. Ricketts has thought deserved a name. The bunch is large and long, and shouldered; the berry is medium or above, roundish-oval in form, black, with a blue bloom; flesh rich, juicy, and sweet; free from pulp. The vine strong, with a large thick leaf; a great bearer.

No. 97.—A very large, round, black grape, with a peculiar rich, juicy, sweet, flesh. It is one of good promise.

Advance.—This Mr. Ricketts has named, and it is certainly so much in advance of any hardy grape yet in our fruit-books, that he perhaps has rightly hit upon the name. It is a large roundish-oval, black berry, a large bunch, and in quality of flesh it is hard to find its superior. Nothing yet grown out of doors in garden or vineyard equals it.

No. 10.—Is a large, oval rounded, reddish-purple grape, in quality surpassing the "Purple Damascus." It is a strong grower, good bearer, and healthy in foliage.

No. 19.—A small black grape; so rich for wine as to go to 109° of saccharometer. For that alone it may be valued.

The Moonwort Ferns.

Most persons, even those who do not study plants, recognize ferns at sight, their habit and general appearance is such that the plants are readily known as belonging to the fern family.

There are some among our native ferns so unlike the majority, that they are likely to be overlooked by those who do not give especial attention to plants, and to be passed by as belonging to some other family. The Moonwort ferns are usually very puzzling, as they have much more succulent fronds than most others, and the reproductive organs, the spores, instead of being placed, as is most commonly the case, in dots upon the back of the frond, are collected by themselves in a sort of panicle, which is really a part of the frond so changed by bearing the spore cases, as to look quite unlike the fertile portion. The botanical name for this genus of ferns is *Botrychium*, which is from the Greek word for a cluster of grapes, to which the fertile portion of the frond bears some resemblance. There are about five species in our Northern States, some of which are rare, but one or two quite common in rich woods. They have clustered fleshy roots from which arise a single frond, one-half of which is sterile, light green, leaf-like, spreading, and usually much divided, while the sterile portion is erect and changed in appearance; the engraving shows the two parts of the natural size; in all the other species the sterile frond is sessile, or attached directly to the common stalk, but in this (*B. lunarioides*), it has a sort of petiole or leaf-stalk. This species varies considerably, and the large engraving shows what is called the variety *obliquum*, and the smaller one a portion of the variety *dissectum*. The other species will be recognized as belonging to the Moonworts, from their general resemblance to this. They are called Moonworts, because in one species, very rare in this country, but common in Europe, the divisions of the sterile frond are shaped like a half-moon. The Moonworts are usually to be found in July or later, and those who take them up with a view to cultivate them, are likely to be much disappointed to find that in spite of all care that may be given them, they soon die. We have on more than one occasion informed our readers of the fact, that the majority of our native ferns are deciduous, lasting only during the summer season. Those sold by the florists, are for the most part evergreens, and those who undertake to cultivate native ferns without

few native species with evergreen fronds, may be cultivated in pots, but for the rest, they should be planted in the open ground, generally all the better if on a rockwork, with the knowl-

in every direction by light colored lines, which run together and form a fine net-work all over the surface; this appearance is apparently produced by a breaking up of the skin of the fruit, and showing a lower lighter colored layer through the cracks. This is so unlike an ordinary cucumber in appearance, as to deceive some experienced horticulturalists, who were quite unable to say what fruit it was. Great hardiness and productiveness are claimed for this variety, and it would be worth growing in the garden as a curiosity, were it not, as it is said to be, of good quality for the table.



MOONWORT FERNS—VARIETIES OF *Botrychium lunarioides*.

edge that their beautiful forms can only be enjoyed during the season of growth, and that they, like other herbs, will sooner or later go into winter quarters. The Moonworts are very desirable in an out-door fernery, as their habit offers a strong contrast to other genera, and they are of the easiest culture, only requiring that they shall not be put in too dry a place, where their roots will be injured by drouth, while they are dormant. In Europe, our native species are valued by fern growers, and they also have species from Ceylon and New Holland, all of which are deciduous like ours, and writers on fern-growing, state that when grown in pots, these too will fail if the roots are allowed to become too dry while dormant.

The Russian Netted Cucumber.

Last spring Messrs. Briggs & Brother, of Rochester, N. Y., sent us, among other novelties, the seeds of the Russian Netted Cucumber. By some oversight these seeds were omitted at sowing time, and we were unable to see the fruit until this fall, when we received a specimen from Messrs. B. K. Bliss & Sons. According to the English seedsmen, this is from the Ukraine country, and was first brought to notice at the Vienna Exposition, where it attracted much attention. The engraving shows the general shape, though some specimens are longer in proportion than this; the skin is of a dark brown color, and intersected

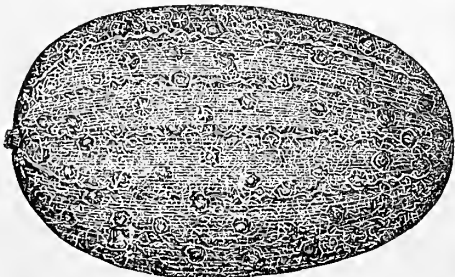

RUSSIAN NETTED CUCUMBER.

knowing this, are apt to attribute their want of success to anything but the right cause. A

A Rustic Porch.

The custom of building ample verandas to houses, even to those of quite moderate cost, is now, we are glad to say, quite common. Still houses, even modern ones, are to be seen, especially in the country, without this most necessary appendage. Nothing can be more inhospitable in appearance than a house without a porch, or stoop, to shelter one from the sun or rain while waiting for the door to be opened. If one is so unfortunate as to occupy one of these desolate-looking porchless houses, there is nothing he can do that will so much improve its appearance as to put a veranda to it, or if he does not care to do that, a simple porch over the door will do much to relieve its nakedness. A porch built of simple style will pay in the comfort it will bring, if one is to occupy the house but a single season. Some time ago one of our associates brought us a sketch of a rustic porch, which some one had put over the door of a very plain cottage, with the effect of changing the whole aspect of the exterior. The engraving shows how this particular porch was constructed, and will serve as a hint for making a tasteful shelter out of very common materials, and there is nothing about it which one of very moderate mechanical skill might not undertake. If red cedar can be obtained, it is preferable for rustic-work of this kind, but other materials will answer if cedar is not at hand. A porch of this kind, when well covered with vines, will, in many cases, be in much better keeping with the

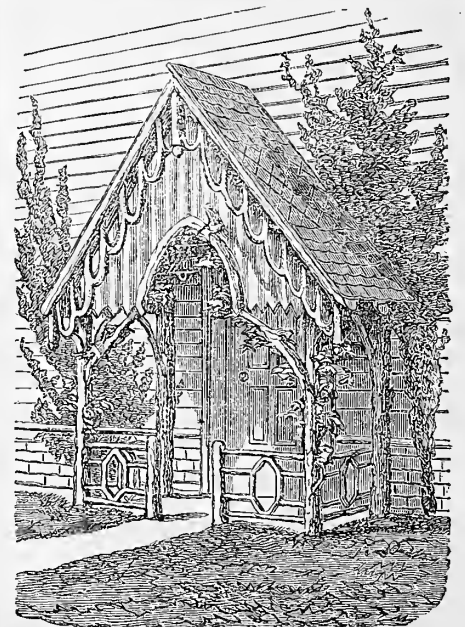

A RUSTIC PORCH.

house, than one made of regular carpentry and costing a much larger sum.

THE HOUSEHOLD.

(For other Household Items, see "Basket" pages).

"Always Handy."

The Fair of the American Institute, which closed last month, besides giving a grand display of large and important machines, had in one of its departments a regular museum of household contrivances. Here were gathered numerous little "crinkums" or "Yankee notions," for facilitating the work of the housekeeper, and among them was a set of articles made by the American Manufacturing Co.,

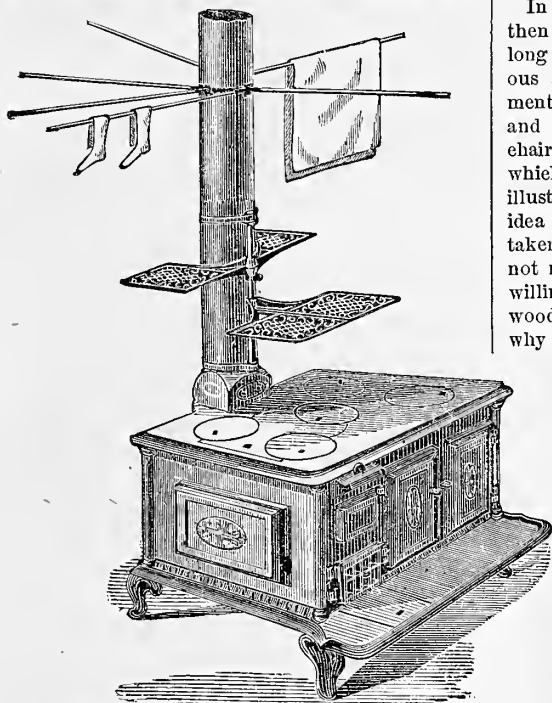

STOVE WITH "ALWAYS HANDY" ATTACHMENTS.

New Haven, Conn., with the attractive trade mark of "Always Handy." These affairs are attachments to a cooking stove, and are intended to increase its capacity for usefulness. They consist of shelves of light open work casting, upon a support made fast to the stovepipe, and which can be placed at any height or swung to any position; the shelves, as may be seen in the engraving, are in pairs, and may be had in single sets of two, or double sets of four shelves. The agent wished us to try this fixture, and it was put upon the stove, where it is likely to remain; being sufficiently high to be out of the way of the pots and saucepans, the shelves are exceedingly handy; they will hold dishes while taking up dinner, afford an excellent place on which to keep dishes warm, they are just the place on which to set bread to rise, or to dry various articles; indeed it is not easy to enumerate the uses to which they may be put. Another contrivance is a towel rack or dryer, consisting of two or four neat walnut or maple rods, so hung at one end as to be turned in any direction, and if need be, taken away altogether in a few seconds; the racks may be attached to the stovepipe, or with a slight modification, may be hung wherever needed. Both the shelves and the towel rack can go upon the same pipe. The manner in which these articles are fixed to the pipe, is simple and effective; a flexible strip of hoop iron has its ends brought together by means of a screw-clamp, which allows of its ready adjustment to a pipe of any size or shape. Though simple affairs, much ingenuity has been expended in rendering them neat, tasteful, and perfect of their kind.

About Condensed Milk.—If Faith Rochester will visit Wassaic, Dutchess Co., N. Y., on the Harlem Railroad, 82 miles from New York, she can see "the process of condensing milk," and

learn that the plain condensed milk, which is sent to the New York market, has no sugar added to it—none at all. It is simply pure milk with the water extracted—this and nothing more. The sugared milk, put up in cans for distant markets and long preservation, is quite a different thing; this has pure sugar added, and nothing else. The process of doing this can be seen at Brewster's, on the Harlem Railroad, 52 miles from New York, and also at Amenia. All these places and factories are well worth a visit.

W. J. M.

A Folding Rural Chair.

In the household department we have now and then suggested work, which did not properly belong to the housekeeper herself. There are numerous articles of household convenience or ornament, which add much to the comfort of the home, and which can be home-made, such as tables, chairs, wood-boxes, and numerous other things, of which our pages in past volumes bear numerous illustrations. If the good housewife has a definite idea of what she wishes made, she has already taken a good step towards having it, and if she can not make the article herself, she can usually find willing and stronger hands to embody her idea in wood or other material. There is really no reason why ladies should not use the saw and hammer themselves; we have known them to do it, and exceedingly neat work they made. Every well appointed farm should have a workshop with the ordinary tools, and mothers should encourage the boys to work in it. Much of what passes for laziness in boys is really timidity and want of motive, and if the mother or older sister can direct such boys, and make them feel that they are doing something that will be of real use, their independence will give place to zeal, and they will take pride in the work. At the outset, the mother or sister should properly consider their design, whether it is to be a simple box or a more elaborate chair, and have the parts accurately measured; unless this is done, a good job can not be expected, and where

boys are to be the workmen, it is of great importance that they be taught to always work to measure. These remarks are not made with especial reference to the design for a chair here given, but apply to such things as have been suggested heretofore, or may be given hereafter. The folding chair is one that is not difficult to make, and is especially useful on the veranda or where a seat is required in the garden. It is intended to be rustic, *i. e.*, made of wood with the bark adhering to it.

In constructing a chair of this kind, the four principal sticks should be selected that naturally have the desired curves; this seems a difficult matter, but those who have had any experience in

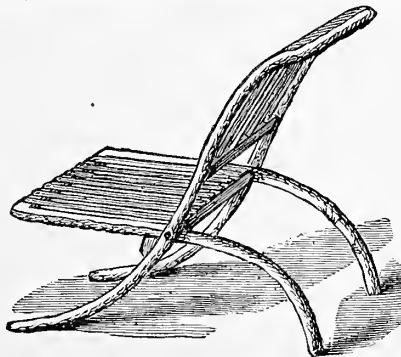

A FOLDING CHAIR.

rustic work, soon learn to see the capabilities of what appears to be unpromising material, and a brush heap is to them filled with useful forms. The wood should be cut at this season, in order that the bark may adhere firmly, and it should be well seasoned. In the lack of sticks with the natural curve, straight ones may be steamed and bent into shape. The pieces should be of oak or hickory or other strong wood, and at least two

inches in diameter at the lower ends. The cross bars are morticed into the side pieces and wedged firmly, and the seat and back made of split pieces firmly nailed on. The two parts are fastened together with carriage bolts. When finished the wood is thoroughly coated with linseed oil. A chair like this will last for many years if put away during the winter; the ability to fold it allows it to be stored in a very small space.

Home Topics.

BY FAITH ROCHESTER.

JENNIE JUNE'S AMERICAN COOKING BOOK.

This book is doubtless familiar to many "to whom these presents may come." Others, who are interested in recipes, may like to hear something about it. I was glad to see the volume at last, exchanging for a little while my copy of Marion Harland's "Common Sense in the Household" with a new neighbor, who had Jennie June's book. In some respects this may be the better book. I fancy that its author understands more clearly than Marion Harland the connection between cooking and health. Both books contain much interesting matter upon general subjects relating to domestic economy. This edition of "American Cookery" was published in 1869; and I am not aware of any later one. In a preface to the new edition the author acknowledges what she believes was an error in a previous edition. She now believes that it is a mistake to dilute cow's milk for infant's food. She thinks it better to sweeten the whole milk very slightly, and warm it by placing the bottle in water, which should be gradually heated. She says that the child is "better nourished on a smaller quantity of fluid and is less liable to flatulence and colic." Those who have young babes to bring up "by hand," will do well to experiment a little in regard to diluting the milk. Physicians have almost unanimously agreed that the milk should have from one-fifth to one-half of water added, but many mothers have thought that their own experience proved the contrary. Remember that it is not our chief object to *fatten* our children, but to give them such elements of nutrition as will produce a steady natural growth, and keep them contented and good-natured and free from disease. Jennie June also recommends prepared barley as a food for infants.

This edition contains an added chapter of Sorosis recipes, and Favorite Dishes of Distinguished Persons. We are told that President Grant is very fond of scrambled eggs and fried ham; while Anna Diekenson "detests everything fried—fried potatoes, fried eggs, or fried mush—while fried beefsteak, such as housekeepers in the West are often heathenish enough to serve strangers, has power to drive her to pull her hair out of curl."

Alas! But why say "housekeepers in the West"? No, I thank you! I do not wish for any of Olive Logan's veal cutlets in curl papers, though she is welcome to cut note paper into heart shapes, oil it, and place her cutlets in it, to make believe they have been fried together, if time hangs heavy on her hands or if she needs such amusement. In fact, this chapter may be a little silly, but the book is a good one, as recipe books go.

In a chapter on "General Principles of Cooking," the author says that the object of cooking is to make food healthful and palatable; that the best food requires the simplest preparation; that cleanliness is the first cardinal principle; that the general rule is to cook long and slowly; that the flesh of grown animals is more healthful than the flesh of quite young ones; that fresh meats are always better than salted or smoked meats; that "the natural order in cooking meats is first to broil, second to boil, third to roast, fourth to stew, fifth to bake, and sixth to fry—and never to fry so long as there is another method left;" that to retain the juices of meat, strong heat should be suddenly applied, so as to close the pores at once, but to extract the juices, as for soup or broth, heat up gradually; that the distinct flavor of each article of food should be retained, for mixtures which make all

dishes taste alike are dyspepsia-breeding as well as appetite-killing; and that food for the well is better than physician for the sick.

NEW FASHIONS FOR WOMEN.

They say that our fashions for feminine garments have long sprung from a very impure source, hence they have been senseless and demoralizing in every way. The fast women of France have led us long enough, and a new era has already begun. Few women, comparatively, have any idea of the excellent work for humanity that the women's clubs are doing. They seem to have the real welfare of women at heart, and have entered earnestly upon a practical work of the utmost importance—dress-reform! In Boston and in New York, and in some other cities East and West, the women of the best intellectual culture and social standing, authors, artists, physicians, teachers, lecturers, and wives of eminent men, have set to work to invent the most healthful and comfortable articles of dress for women, and to secure their adoption. The ignorance of women generally, of the first principles of healthy living, stands chiefly in the way; so lectures on physiology, with special reference to dress, are to be given free to women and to school-girls. By and by, we are to have tracts upon the subject scattered through the country. The Dress Committee of the New England Women's Club seek to make the changes in woman's dress as unobtrusive as possible. They begin with the under-garments. Those of the old style, which they utterly condemn, are the chemise and the corset. Those they entirely abandon. The principles which they attempt to carry out are these—perfectly free action for the vital organs, thus abolishing all tight-fitting waists and all tight bands around the waist; an equalizing of the heat of garments over the entire body, thus lessening the amount of cloth worn over the lower part of the body, and increasing it upon legs and arms; a reduction of the weight of the clothing by making skirts as few and light as possible; the supporting of all clothing from the shoulders, by attaching skirts to waists or suspenders.

The garments already devised, which embody these principles, are the Chemiloon and the Gabrielle underskirt. The first is made of flannel or cotton, a long-sleeved waist and drawers in one, covering the person from waist to ankles. Outer drawers may be buttoned to these. The stockings drawn over the long drawers fitting at the ankle, are fastened with safety pins or with buttons on the drawers. No garters are allowed, because these hinder the circulation of the blood. The Gabrielle underskirt is made of white cotton usually, gored from shoulder to hem, after the plain gabielle pattern rather loosely fitting, and sufficiently short and scant. The outer skirts button upon it, so arranged that one band does not lie over another. If a hoop is worn, (and this is recommended, as it keeps the folds of the skirts from clogging the limbs in walking, and holds the tops of the other skirts so as to prevent undue heating of the pelvis and spine) there should be a stout button hole in the middle of the back of the hoop-band, to fasten upon a strong button on the back seam of the underskirt waist. On each side of this button-hole place the buttons for holding common suspenders, placing the front buttons just over the firm side terminations of the upper hoops. This brings the suspenders back under the the arms, so that they do not interfere with the bust. The balmoreal may rest upon this hoop, with a binding made in semicircular shape, so as to lie upon the skeleton below its binding.

For outer dress the plain gabielle pattern is recommended, not too full in the skirt, and lightly trimmed if trimmed at all. This for the house dress; and an added polonaise or overskirt and short sack for the street.

Thus do the educated American women advise us to dress, and their recommendations are worthy of good heed. In cold weather more than one pair of chemiloons at a time is advised, one perhaps of flannel and one of cotton, or two of wool if more comfortable. All hail the chemiloon! say I, and I suppose that I am not the only obscure

woman, who quietly discarded one of the garments, utterly condemned by the N. E. Woman's Club long ago, for long-sleeved and high-necked shirts, and who never has worn the other instrument of torture.

WARMED-OVER POTATOES

Because only a few potatoes were left from dinner, that is no reason why they should be thrown in the cow's pail. Peel them if not done already, and bake them over in the oven. Or slice them and warm them with bread—which is even better than potatoes warmed alone. This is the way. Put bread crumbs soaking in milk upon the stove. When hot add the sliced or chopped potatoes with salt, and stir all well together till thoroughly heated or cooked. Then season as you wish with a little butter or cream.

THICKENING.

It makes a deal of difference with your cooking, how you stir up sauce thickening for gravy or pudding. You use flour or starch of some kind, mixed with water or milk. Wet the flour with very little water or milk, and beat thoroughly together till every lump disappears, then thin with more water or milk and beat well again. Let the milk or whatever is to be thickened, be actually boiling, and stir as fast as possible while you slowly add the thickening, beating rapidly for two or three minutes. This makes the gravy or custard wonderfully light and foamy, especially if there are beaten eggs in the compound. If you try to mix a little flour with a good deal of water, you will have a long hard siege in getting out the lumps. Salt should be added before the thickening goes in.

THE USE OF DRY YEAST.—Some excellent kinds of dry yeast may be purchased at our groceries. I said once that these cakes were so slow in rising if mixed at once with the sponge that they were chiefly useful for raising new yeast. Not long afterwards I found that this slowness to rise (or to start to rise) gave them great value for summer use, when it seemed desirable, as it usually does, to do the baking early in the morning. Bakers' yeast, or any kind of quick, soft yeast, is so apt to sour before morning on a hot summer night, that a slower kind of yeast is often preferable. I have found it perfectly safe to mix my bread sponge before dark in summer, stirring in the yeast-cake as soon as it was soaked soft in a little warm water, and have never had bread mixed with this yeast become sour during the night or while waiting for me in the morning. I am confident that I know sour dough when I smell it or taste it, as many house-keepers certainly do not. Else why do they make sour bread week after week, year in and year out? Or why do they persist in regularly putting in soda as a necessary step in the process of bread-making?

Those who make dry yeast for themselves should be very careful not to let it get sour while drying. It should be dried rapidly in a good, cool, drying wind. It is unsafe to dry it in the sunshine or by the stove, lest it may sour from excess of heat. It should be mixed with a good deal of corn-meal, and then made into small thin cakes, or—better still, I think—dropped in small crumbs upon a board to dry. Any kind of good, lively, soft yeast may be mixed with meal and make dry yeast. In winter it is best to put the dry yeast, soaked in warm water, rising in a bowl of flour and warm water batter three hours before setting the sponge.

Homes and How to Make Them.

The above is the attractive title of a work by E. C. Gardener, and published in elegant form by J. R. Osgood & Co. This is not, strictly speaking, an architectural work, though it has much to say about architecture; it is a series of letters from persons about to build houses of their own, to their friend, who is an architect, and the architect's replies. The correspondence is bright and pointed, and on the one side shows the difficulties and doubts besetting the intending builder, and on the other the

removal of these troubles by advice and suggestions. The book is characterized by great common sense, and if one contemplates building a new, or remodeling an old house, the perusal of this work will afford many useful hints, and set the thoughts of the reader in the right direction. An extract or two from the book will give an idea of its style, and perhaps be of use in themselves. The author pleads for

ABUNDANT SUNSHINE;

for plenty of windows in the first place, and then their freedom from obstruction by blinds and shutters. We have been long in doubt if carpets have not, on the whole, done quite as much harm as good. A few years ago we visited a house, the lady of which had long been noted for the number and beauty of her window plants; on the occasion referred to, after asking about the rest of the household, we inquired as to the plants; the lady apologetically told us that a few months ago they had newly carpeted their rooms, and not wishing to fade the carpets by the light necessary for the plants, these were given up. Here, instead of a cheerful parlor, with its windows filled with plants, the natural flowers were banished, and shutters closed, all that the miserable caricatures of flowers in a carpet might not lose any of their unnatural brightness. Our author pleads for sunlight, not for plants, but for the comfort and well-being of the household. He says: "Let your doors and windows be wide, and your roof be high. A wide door is far more convenient than a narrow one, usually much better in appearance; and for the windows—when shall we learn the unspeakable worth of the bountiful light of heaven? Does Mrs. John complain that the sunlight will fade her carpets? Let them fade, and know of a truth that all the colors of all the carpets of all the looms that ever throbbed, are not worth to the civilized mortals who tread the dust-containing fabrics, one single hour of unobstructed sunshine. Is it that our deeds are evil that we seem to love darkness rather than light or is it through our ignorant exclusion of this glorious gift 'offspring of heaven first born,' that we are left to wander in so many darksome ways? Be generous did I say? rather try to be just to yourself."—In his advice to build the roof high, the author has in mind that which modern architecture ignores. To our notion the children of the present day are deprived of one of their choicest rights. How can a child ever look back with pleasure upon its early home if it had no garret? Writers lament that there are no children nowadays, that there is no intermediate state between infancy and young ladies and gentlemen. An evolutionist would, we think, have little difficulty in tracing this precocity to

HOUSES WITHOUT GARRETS.

Here is what the author of "Homes and how to make them," says: "You will lose too, under the flat roof, the roomy garret of the old high-roofed houses. These have for me a wonderful fascination. Whether the rain upon the shingles, the mingled fragrance of seeds and drying herbs, the surprising bigness of the chimney, the mysteries hidden in the worm-eaten chests, the almost saintly charm of long-unused spinning-wheels, crumbling mementoes of the patient industry of former generations, or the shine of the stars through the chinks in the shrunken boards, the old garret and all its associations, are among the 'long, long thoughts.' I sometimes doubt whether the modern conveniences we are so fond of proclaiming, are really an equivalent to the rising generation for this happiest of play-rooms, this store-house of heir-looms, this silent but potent tie that binds us to the life, the labor, and the love of the past. Let there be light too in this upper story. Spinning spiders and stinging wasps are not half so terrible to the children who will make a half-way paradise of the garret, as the darkness that is covered by an unlighted roof."—While we have found much to commend in this work, we must express our surprise that the author, who is so generally accurate in treating of ventilation, should speak of carbonic-acid as carbon. This he does more than once, and should hasten to rectify.

BOYS & GIRLS' COLUMNS.

About the Dog Carlo.

BY MARY TREAT.

Carlo was a lost or forsaken dog, and he appealed to my sympathies so strongly, that I begged he might be allowed to remain with us. He was a mongrel, not handsome, yet with a soft, silky coat, and intelligent looking eyes. There was nothing remarkable about him except his strong affection and devotedness, and his love of bright colors, especially scarlet, or any of the bright shades of red. My attention was first drawn to his love of colors, by his seeming admiration of a bed of bright colored flowers, (*Phlox Drummondii*), in which red strongly prevailed. He would stand or lie by these flowers apparently in rapt admiration for a long time together, never stepping on the bed, nor lying on the flowers. The evident pleasure he took in the red flowers, led me to experiment with him, and I found it was only a mass of color that attracted him, a small cluster of flowers he paid no attention to, but a large, bright bouquet, he admired. And it was the same in dress; a red shawl that I sometimes wore, was his special delight, while a red ribbon he paid little or no attention to. When preparing for a walk, he would look at me inquiringly, if I took a black or gray wrapper, he showed no interest, but let me change it for red, and I had his most decided approval, he would gambol and frisk about me, evidently so much more delighted to accompany me, now that I was in this presentable costume!

So little do we comprehend the artistic taste and sagacity of the lower animals, that I might have worn that shawl for a long time, had it not been for the accident of the *Phlox*, and never have known why my dog was so much more sportive and happy at one time in accompanying me in my rambles than at another.

Carlo from the first formed a strong attachment for my pet cat, which was mutual; he often put his paw over her in a caressing way, and she would purr and rub against his legs, and she frequently brought game and placed before him, which he always magnanimously refused!

After a while the cat became mother to two kittens, and for a time they seemed to engross all her attention, and I feared the strong friendship between my pets had ceased, until I saw the cat at her old tricks again; purring about Carlo; but now she seemed to have an object in view, she would rub against his legs and then start off a short distance, looking back as if she expected him to follow, and he did follow a little way, but finally he laid down, as if in despair to comprehend what she wanted. The cat now disappeared, and after a short time returned with one of her pretty, plump kittens in her mouth, and laid it down before him. Upon this Carlo got up and gazed at it with an astonished look, and then ventured to put his nose toward it; this aroused the indignation of the kitten, and it spit and struck at him like a little fury, and Carlo walked away abashed, whereupon the cat brought the kitten to me, seemingly disheartened with her attempt at an introduction to Carlo, who watched me closely while I fondled it, with a jealous look that I never saw manifested toward the mother.

Carlo was on the best of terms with all the dogs of the neighborhood. I am inclined to think he was too much of a coward to attack a dog of his own size, and was too good natured to snarl at one less than himself. When meeting a dog of his acquaintance larger than himself, and sometimes one about his own size, he acted precisely like Mr. Darwin's dog, of which he says:

"I formerly possessed a large dog who was not at all afraid to fight with other dogs; but a wolf-like shepherd dog in the neighborhood, though not ferocious and not so powerful as my dog, had a strange influence over him. When they met on the road my dog would run to meet him, with his tail partly tucked in between his legs and hair not erected; and then he would throw himself on the ground, belly upward. By this action he seemed to say, more plainly than by words: 'Behold, I am your slave.'"

It was next to an impossibility to set Carlo to drive any animal that belonged to the farm, except chickens, he would always drive them from the lawn, and soon learned to do it of his own accord, but never interfering with, nor chasing them outside of the lawn. But he always drove strange cattle or hogs, and if the latter showed fight, he could be quite savage.

One day two small white pigs escaped from their quarters and came on to the lawn, and in vain I urged Carlo to drive them off; he started down to them quick enough, and to my surprise the pigs recognized him as an old friend, and commenced playing with him, and a wild frolic they had. After watching them a while, I scolded, and urged Carlo to drive them off. He would then pretend to try to drive them, barking and frolicking about them, and looking back at me in a comical way, as much as to say, "See, I can't make them go!"

On relating this to one of the family, he informed me that Carlo had a regular frolic every day with the pigs, (which were kept in a large field), and sometimes the old ones joined in the play.

Aunt Sue's Puzzle-Box.

DOUBLE ACROSTIC.

The initials and finals form two cities in the State of Massachusetts.

1. A musical instrument.
2. One of the United States.
3. A tool.
4. A number.
5. A bird.
6. A girl's nickname.

WILLIE WEBSTER.

DIAMOND PUZZLE.

1. Always seen in battle.
2. A unit.
3. A color.
4. A city.
5. A mountain.
6. To mar.
7. A river.
8. Quantity.
9. A quarter of a half.

The center letters, horizontal and perpendicular, form a mountain.

CROSS-WORD.

My first is in heaven but not in earth,
 My next is in value but not in worth,
 My third is in light but not in dark,
 My fourth is in fire but not in spark,
 My fifth is in spring but not in fall,
 My sixth is in boat but not in yawl,
 My seventh is in ink but not in paper,
 My eighth is in candle but not in taper,
 My ninth is in June and also in May,
 My whole is a saint, or so they say.

MOLLY.

SQUARE WORD.

1. A fish.
2. A country.
3. Quiet.
4. A girl's name.

A. L. FRED.

ALPHABETICAL ARITHMETIC.

HARBOCKEKL(LOCB
 BLOH

COAE
 CCHH

LHCK
 LKKL

SAL
 HAR

LSC

W. S. H., Jr.

PI.

Ekta tch peads fo cavernspcere,
 Gid het delif io sporgers iwed,
 Reevy brontulhs dwce fo fatcoin
 Rowry tou dan cats sadic.

FRANK A. MURTHA.

ANAGRAMS.

1. Cast me a Modoc.
2. Banns settle him.
3. I hless pain, Ncd.
4. Aired tents.
5. Spritc scenc.
6. Troop in Paris, Pa.
7. O! a troop is printed.
8. A rain-storm font.
9. A fusil coal.
10. Rats' membranes.

ARITHMOREMS.

- 1.—66500.
- 2.—7500500.
- 3.—10050014.
- 4.—130025010.
- 5.—1505005550.
- 6.—40500.
- 7.—1150111.
- 8.—8000500.
- 9.—090015010.
- 10.—200050010.

SUNKAKU.

NUMERICAL ENIGMA.

1. I am composed of 14 letters:
 My 6, 2, 8, is what every boy is.
 My 9, 10, 4, 3, is an article of furniture.
 My 3, 4, 12, 13, 5, is an animal.
 My 1, 7, 14, belongs to a fish.
 My 2, 11, 1, is a pronoun.
 My whole is a name with which you are all familiar.

C. B. ESTES.

ANSWERS TO PUZZLES IN THE OCTOBER NUMBER.

DOUBLE ACROSTIC.—Sacramento, Shenandoah.
 St. Thomas
 A— —H
 C— offc —E
 R— avc —N
 A— nn —A
 M— onr —N
 E— meral —D
 N— eosh —O
 T— hercs— A
 O— — —H

NUMERICAL ENIGMA.—Atlantic Ocean.

METAGRAM.—Chinchilla: in which may be found 1 two c's (two seas), 2 two I's, 3 chin, 4 inch, 5 hin, 6 chinch, 7 China, 8 ill, 9 hill, 10 la, 11 chill, 12 hail, and 13 in.

PI.—The path that leads to fortune too often passes through the narrow defiles of meanness, which a man of exalted spirit can not stoop to tread.

CROSS-WORD.—Farming.

CONCEALED CAPES.—1. Ann. 2. Malm. 3. Race. 4. Roca. 5. Romaine. 6. May. 7. Orange.

TRANSPOSITIONS.—1. Hero, hoer. 2. May, yam. 3. Peon, ponc. 4. Dean, Dane. 5. Kiln, link.

CHARADE.—Rupcc (rue—pea).

DIAMOND PUZZLE.—Chicago.

C
 S H I E
 S P I T E
 C H I C A G O
 M E A N S
 A G E
 O

WORD-SQUARE.— J A C K
 A L O E
 C O R N
 K E N O

Send communications for the Puzzle Box to Aunt Sue, Box 111, P. O., Brooklyn, N. Y., and not to 245 Broadway.

Aunt Sue's Chats.

EFFIE S. W., wants to know the origin of the saying, "robbing Peter to pay Paul." In the time of King Edward the Sixth, of England, his ministers and courtiers appropriated a large part of the lands belonging to St. Peter's church, at Westminster. The people were indignant at the robbery, and to reconcile them, a portion was set apart to pay for repairing St. Paul's church, and so the people talked about robbing Peter to pay Paul, until the phrase became proverbial.

G. W. TOMLINSON.—That is an old joke, "can a man keep his feet dry when he has a creak in his boots?" but I wonder no one has suggested that he should get pmpms.

EMMA.—You may improve the cane-bottom chairs very much, by washing the seats with hot soapsuds and putting them in the air to dry quickly; it whitens and tightens them.

LULU.—I never like to pronounce judgment upon a case without hearing "both sides of the story," and I have not heard your teacher's side; but why keep dwelling on the "thorns that accompany the roses," why not be glad that roses accompany the thorns?

MARY L. BARTLETT wants to know "If lobster's claws really grow again after they are broken off." I don't know, Mary dear, from my own personal observation, but naturalists say they do, and that in three weeks a leg or claw is replaced by one nearly as large and strong as the one lost. In finding out that fact for your edification, I read what astonished me more than the new growth of a lost member, and that was that lobsters like raw oysters for their dinner, and in order to get at them, they watch till the oyster opens its shell, then pop a stone in, so that the oyster can not shut it again. Whereupon the lobster, so this account says, eats the oyster (without pepper or vinegar). I was not astonished at their liking a raw oyster, but at their gumption of getting a stone to wedge open the oyster-shell.

FRANK.—A very neat little "trick," is to tell whether a person holds an odd or even number of pennies (buttons, beans, or what not) in the right or left hand. Give a person an odd number of beans, say nine, eleven, thirteen, or fifteen; tell him to hold an odd number in one hand and an even one in the other; ask him to multiply the contents of the right hand by three, five, seven, nine, or eleven, (always an uneven number,) to multiply those in his left hand by two, four, six, eight, ten, or twelve; let him tell you the product of the whole. Should it be an even number, it proves that the even number is in the right hand; if the sum total be odd, the odd number is in the right hand.

EXAMPLES.

Right hand.	Left hand.	Right hand.	Left hand.
6	9	9	6
3	2	3	2
18	18	27	12
18		12	
36		39	

Instead of one person holding all the beans, they may be divided between two, the performer mentally distinguishing them as right and left; try it.

F. L., asks if I "know any words containing all the vowels." Yes, lots of them. "Abstemiously," and "facetiously," contain the vowels in their proper order. In the following they all occur, but irregularly: Authoritatively, consequentially, disadvantageously, encouragingly, efficaciously, instantaneously, impudently, mendaciously, nefariously, precariously, pertinaciously, sac-



FAMILIARITY ON SHORT ACQUAINTANCE. — Drawn and Engraved for the American Agriculturist

religiously, simultaneously, tenaciously, unintentionally, unobjectionably, unequivocally, undiscoverably, vexatiously, and unquestionably many others.

Making Himself at Home.

Of all animal pets there is none that boys and girls like better than rabbits, especially the white ones. Men who raise rabbits generally like other kinds, such as the monstrous fellows with lop-ears, which make one think that the starch was left out when they were washed, or those from Madagascar or some other far-off country, very expensive, but very ugly. Rabbits are not very intelligent, but they are so tame and so little trouble that all young folks like them. By so little trouble is meant that they are easily taken care of, but if the rabbits happen to get out into the garden, where they can have a frolic of a moonlight night, there will be "trouble" enough in the morning. Many like rabbits that are black, or brown, or of other colors, but none look so nice and clean as the white ones. How long and pretty their ears are; you perhaps think they are only intended as handles by which to lift the animal, but that is not the case; the rabbit has neither claws nor teeth that will do much in fighting, so the animal for its safety depends upon running, and it has its ears so long, for the reason that the wolf in the story told Little Red Ridinghood, "all the better to hear, my dear." Your little pet rabbits can show you one of

the many ways in which the Creator has made animals fitted for the conditions in which they live, and if He did not give the rabbit the power to fight its enemies, He gave it very swift legs, and quick-hearing ears to tell it when to use them. Just look at the beautiful thin ears as the sunlight shines through them, and see the veins and arteries. How funny the little fellows nibble, and how they seem to enjoy eating—indeed that is about all the fun they seem to have. Perhaps you think that the little brown rabbit, that every one of you who has been much in the country knows, is just the same as your pets, only wild; we have no proper rabbit in this country; all those wild ones that are called rabbits, are hares. You would like to know the difference, well, there is not a very great one, the main thing is that hares never make burrows, while the rabbits do. In Europe, where they are wild, they make regular underground villages, or warrens as they are called. Perhaps you do not know that the white rabbits, pink-eyed, you admire so much, are in their wild state gray or some other color, and that your white ones are *albinoes*. You will have to go to the dictionary for that word, unless it is explained here. It often happens that animals that are naturally dark colored, have now and then young that have white hair and pink eyes. White mice, which are sometimes kept as pets, are *albinoes*, and so are white rats; blackbirds, sometimes have *albinoes*, and so do crows, and other birds that are usually dark colored; men and women, even Africans, are sometimes *albinoes*, and have

white silky hair and weak pink eyes. We have said so much about the real rabbits, that the picture is almost forgotten, but there is one curious thing we must tell about one of our wild rabbits, or rather hares: We said that the rabbit was given long ears for its safety; this hare lives far north, where the winters are long and the snow is on the ground for many months. In summer its modest brown coat is so much like the ground, that a prowling wolf or fox could not see it a great way off, but if the animal should run upon the snow, its brown color could be seen at a great distance. Now what do you suppose this hare does? Just as you would do if you wished to hide on the snow, it dresses from top to toe in pure white. It is not right though to say that the hare does it, for the animal could not help itself, but the good Father who cares for even the hares away upon the arctic snows, so made this animal that its coat will change with the season. Isn't that quite as strange as some of the wonder stories? But the picture. We have had a good laugh over it, for the artist has given so much expression to these usually rather stupid animals. Evidently the central dark rabbit is a new comer; when he was put with the rest he seemed to be very bashful, but now he is making himself quite at home, and is getting on the best of terms with the white one. The father of the family is astonished at the impudence of the new comer, and evidently thinks, "Well, this chap is making himself at home." And the fellow at the left, how jealous he looks at the familiar new comer!

Life Insurance.

Among the many considerations which give the subject of life insurance a claim on our attention, is its bearing on the most sacred obligations of humanity. By the decree of Divine Providence, every head of a family is bound to provide for the maintenance of the members of his own household. The husband must support and cherish her who, at the altar, was given his care. The father must provide for the maintenance and education of those who, through him, have received their being. The laws of society require this; the laws of nature suggest it; the laws of religion commend it; the common sentiment of mankind insists upon it.

Every man is bound to secure, as far as lies in his power, the support of those whom he has been instrumental in bringing into the world. Thus, while the father lives, he owes his toil to them. For their sakes, he must be content to "rise up early, and late retire to rest, and eat the bread of carefulness." In all the wide world, there is no one to whom he rightfully can transfer this responsibility; and it is a responsibility which no one, possessed of the true feelings of a man, wishes to be rid of. Toil is sweet when it is performed for those whom one loves, and who, in love, are dependent on his care. But human life hangs by a slender thread. The strong arm of the bread winner is liable at any time to fail those who are dependent upon it for support. The father can have no security that his life shall be prolonged till his helpless flock shall no longer need his labors. Is there no duty laid upon him in view of a contingency of this sort? Is not every household head bound most sacredly to make provision, as far as possible, against the evils which his death might entail on his dependents?

The duty of life insurance is therefore plain. The only question is: Where shall it be obtained? If more than a quarter of a century of honorable dealing; if ample assets, distinguished success, good management, and exceeding popularity—if these are indications, or tests, of the proper company to insure in, the United States Life Insurance Co., of this city, may safely appeal to either, or to all of them.

A YOUTH'S PUBLICATION.—For nearly half a century the *Youth's Companion*, of Boston, has been published. It was started in 1827, and is to-day one of the brightest and most vigorous papers with which we are acquainted.

And Not Wear Out.
A KEY THAT WILL WIND ANY WATCH.
For sale by Watchmakers. By mail, 50 cents. Circulars free. J. S. BIRCH, 37 Maiden Lane, New York.

**GEO. A. PRINCE & CO.
ORGANS & MELODEONS.**

The Oldest, Largest and Most Perfect Manufactory in the United States.

54,000

[Now in use.

No other Musical Instrument ever obtained the same popularity.

Send for Price-Lists. Address **BUFFALO, N. Y.**

A SILVER TIP

Adds Five Cents

TO THE COST OF A SHOE, and \$1 to its value.

MONEY MADE RAPIDLY with Stoneil and Key Check Outfits. Catalogues and full particulars free. S. M. Spencer, 117 Hanover st., Boston, Mass.

\$290 Piano. Circulars free. U. S. Piano Co. 810 B'dway, N. Y.

Waltham Watches.

HOWARD & CO., No. 222 Fifth Avenue, New York, continue to send single Waltham Watches by Express or Mail to any part of the Country, no matter how remote, without any risk to the purchaser. Having sold Waltham Watches on this plan for the last six years, their customers are numbered by thousands, and from almost every county in the Union. In every case the purchaser gets a good, reliable Watch, and full value for the money. Great improvements have been made during the present year; all grades and sizes are now made both as key-winders and stem-winders. Our new price-list, which is sent free, describes all the new Watches with prices of each. Write for it, and mention that advertisement was seen in the *American Agriculturist*. Address HOWARD & CO., 222 Fifth Avenue, New York.

"A TRIAL TRIP." The Science of Health, a First Class Health Magazine, at \$2 a year, will be sent 3 months "on trial" for 25 cts. Single numbers, 20 cts. Agents wanted. Great Premium Offer. Sewing Machines at wholesale for subscriptions. The Illustrated *Phrenological Journal*, \$3 a year, or single No. 30 cts., sent 3 months "on trial," at 50 cts. Try it. S. R. WELLS, 389 Broadway, New York.

IT IS NOT ECONOMY

To buy a poor Shoe. Try Good

Cable Screw Wire FOR ECONOMY.

SEND FOR IT!

BRIGGS & BRO'S ILLUSTRATED

FLORAL WORK

For JANUARY, will be out about December 1st, containing a full list of the 2,500 varieties of

FLOWER AND VEGETABLE SEEDS

Grown and imported by this celebrated firm, illustrated with Four Hundred Engravings, and containing a vast fund of horticultural information, alike useful to the amateur or the professional—unlaid prepaid to any address on receipt of 25 cts., not one-third its value; also entitling the sender to the three subsequent Numbers.

Over 1000 PREMIUMS taken on the product of Briggs & Brother's Seed in one season.

BRIGGS & BROTHER, Rochester, N. Y. or, Chicago, Ill.



Rifles, Shot Guns, Revolvers, Pistols, Ammunition, Fishing Tackle, etc. For Price-list, see page 157, April No. *Am. Agriculturist*, or address, with stamp, GREAT WESTERN GUN WORKS, 283 Liberty St., Pittsburgh, Pa.

ASBESTOS ROOFING PAINT.

A strictly first-class article, superior body, rich color, contains no tar or cheap oils. Old Shingle, Tin, and other Roofs can be made water-tight, and rendered serviceable for many years with H. W. JOHNS' Patent ASBESTOS ROOFING PAINT and ASBESTOS CEMENT. **ASBESTOS ROOFING, FOR STEEP OR FLAT ROOFS, IN ALL CLIMATES.** ASBESTOS PAINTS, all colors, for general purposes, in cans, kegs, and barrels. ASBESTOS BOILER FELTING, Sheathing and Lining Felts, general Roofing Materials, &c. These materials are prepared ready for use, and can be easily applied by any one. Send for Descriptive Pamphlets, Price Lists, Instructions, &c. **LIBERAL INDUCEMENTS TO GENERAL MERCHANTS and DEALERS.** CAUTION.—The public are hereby cautioned against purchasing or using any materials for the above or similar purposes, purporting to contain ASBESTOS, unless they bear our name and date of patents. **Patentee and Sole Manufacturer, H. W. JOHNS, 87 Maiden Lane, N. Y. ESTABLISHED 1855.**

National Live-Stock Journal, CHICAGO.

The only first-class paper in the United States devoted exclusively to Live-Stock. A large 36-page monthly, every number handsomely illustrated. Every Farmer and Breeder, and every person owning a horse, pig, cow, or sheep, should read it. TERMS.—\$2.15 per year, including postage. Large reduction to Clubs and Agents. For 50 cents extra an elegant Cattle Picture, 24x30. For \$1 extra, a Chromo, 16x20, of Goldsmith Maid. **SPECIMENS FREE.** Address, **GEO. W. RUST & CO., CHICAGO, ILLS.**

EDDY! COOKMAN!!

The Methodist,

PUBLISHED WEEKLY AT No. 114 Nassau Street, New York.

TERMS, \$3.00 PER YEAR, [INCLUDING POSTAGE.]

CONTAINS TWENTY PAGES EVERY WEEK. A Magnificent Engraving or a Splendid Chromo given to Every Subscriber.

Every subscriber to THE METHODIST will be entitled to a choice portrait of the late **Rev. T. M. EDDY, D.D.,** or **Rev. ALFRED COOKMAN,** either of which is richly worth the subscription price of the paper. Or, if preferred, our fine Steel Engraving by Battre, containing portraits of Wesley and all the Bishops of the M. E. Church.

The above **ENGRAVINGS,** or the Chromo of **The Old Arm-Chair** or the **Young Students,** are **GIVEN AWAY,** there being no extra charge, except 10 cents for mailing expenses.

Those desiring *Specimen Copies* will be supplied on receipt of a two-cent postage stamp, to prepay postage on the same.

CANVASSERS wanted everywhere, to whom liberal commissions or premiums will be allowed.

In remitting funds for Subscriptions, send by P. O. Money Order, Registered Letter, or Bank Check. Payable to

THE METHODIST, 114 Nassau St., N. Y.

(CIRCULAR.)

Consumers' Importing Tea Co., No. 8 Church Street, P. O. Box 5,509. New York City.

This is a combination of capitalists to supply the consumers of Teas throughout the United States on the mutual principle.

We have experienced agents in all the best districts of China and Japan to select Teas especially for our trade.

We expect every consumer of Teas to render us all the assistance they can in carrying out our enterprise, as we make a specialty of **SUPPLYING CONSUMERS ONLY** (and allow no middlemen to make any profit on our importations), which will enable us to supply them with Teas at prices lower than have ever been known, and of those fine qualities that seldom reach the interior, being sold only in the large cities and among the very wealthy.

Hoping the consumer will take an interest in our enterprise, and send at once for a circular with full explanations of how to proceed to obtain our goods, we remain,

Most respectfully yours,

Consumers' Importing Tea Co., No. 8 Church Street, P. O. Box 5,509. New York City.

Entered, according to Act of Congress, in January, 1874, by the Consumers' Importing Tea Co., in the Office of the Librarian of Congress, Washington, D. C.

GOOD CROPS Depend on good Seed, good Soil, good culture. So **Good Health** depends on **Right Living,** and the proper observance of the **Laws of Life,** as taught in the **Science of Health.** \$2 a year; or, "On trial" 3 months for 25 cts. Single numbers, 20 cts. Agents wanted. Great Premium Offers. Sewing Machines at Wholesale. **Phrenological Journal,** 3 months, "on trial," for 50 cts. A year, \$3. S. R. WELLS, 389 Broadway, New York.

WICKS

FLOWER AND VEGETABLE GUIDE

No. 1 for 1875

PUBLISHED QUARTERLY.—The January number is just out, and contains over **100** pages, **500** engravings, with descriptions of more than **500** of our best **Flowers**, and of all our leading **Vegetables**, with full and plain **Directions for Culture**.

The Guide is elegantly printed, a model of typographical beauty, on the choicest tinted paper, and the engravings are of the finest character. It is the most useful and beautiful work of the kind in the world.

The other numbers are published in March, June, and August, making a book of over 200 pages, and all for **25 cents a year**, including a beautiful colored lithographed Frontispiece. A German edition published. Address

JAMES VICK,
Rochester, N. Y.

THE YOUTH'S COMPANION
A WEEKLY PAPER FOR
YOUNG PEOPLE
AND THE
FAMILY

THE COMPANION aims to be a favorite in every family—looked for eagerly by the young people, and read with interest by the older. Its purpose is to interest while it amuses: to be judicious, practicable, sensible, and to have really permanent worth, while it attracts for the hour.

It is handsomely illustrated, and has for contributors some of the most attractive writers in the country. Among these are:

- | | |
|---------------------------|---------------------------|
| J. T. Trowbridge, | Dr. I. I. Hayes, |
| Edward Eggleston, | Rev. W. M. Baker, |
| Louisa M. Alcott, | Louise C. Moulton, |
| Rebecca H. Davis, | C. A. Stephens, |
| Ruth Chesterfield, | Geo. M. Towle. |
- Its reading is adapted to the old and young, is very comprehensive in its character. It gives
- | | |
|--|-------------------------------------|
| Stories of Adventure, | Stories of Home and |
| Letters of Travel, | School Life, |
| Editorials upon Current Topics, | Tales, Poetry, |
| Historical Articles, | Selections for Declarations, |
| Biographical Sketches, | Anecdotes, Puzzles, |
| | Facts and Incidents. |
- Religious Articles.**

Subscription Price, \$1.75. This includes the payment of Postage by the publishers.

Send for specimen copies, which will be sent free. Please mention what paper you saw this in.

PERRY, MASON & CO.,
41 Temple Place, Boston, Mass.

ARTHUR'S

ILLUSTRATED HOME MAGAZINE.

Bright, Cheerful, Progressive, always up to the advancing thought of the times, the HOME MAGAZINE takes rank with the leading and most influential periodicals of the day.

It is on the side of Temperance and true Christian morality. Whatever is hurtful to Society it condemns without fear or favor, and makes itself felt in the Homes of the People as a power for good.

1875

THE GREAT HOUSEHOLD Magazine of America, is more thoroughly identified with the People in their Home and Social Life than any other periodical in the country.

"DEBORAH NORMAN: HER WORK AND HER REMEDY," A new serial story By T. S. ARTHUR will be commenced in January.

"FIFTY YEARS AGO; OR, THE CABINS OF THE WEST," By ROSSELLA RICE. These papers will be fresh and new, and of unusual interest.

"THE STORY TELLER," This department will be unusually rich. Besides an abundance of Short Stories, two or three serials will be given during the year.

BUTTERICK'S NEWEST PATTERNS for ladies' dresses and children's dresses are given by special arrangement every month.

"THE LION IN LOVE," and **"THE INFANT TERROR,"** two large and splendid premium engravings. One of these is sent free to every subscriber.

\$2.50 a year is the price of "ARTHUR'S ILLUSTRATED HOME MAGAZINE." In clubs; 3 copies for \$6; 6 and one extra to get up of club \$12; 10 and one extra \$20. 15 cents must be added to each subscription for prepayment of postage for the year. Specimen numbers 15 cents, in currency or postage stamps.

T. S. ARTHUR & SON, Philadelphia, Pa.

Five Thousand Good Books

for sale, at a discount of 30 to 60 per cent from usual prices. Our third Great Clearance List sent free.

BATES & LAURIAT, Boston.

ROSES.

The undersigned offers a quantity of Roses, unequalled in quality, best market varieties, from open ground.

Hardy Perpetuals, at \$15 per 100.
Monthly and Teas, at \$12 per 100.

Trade-list free on application.

J. M. KELLER, Florist, 56th St. and 3d Ave., Brooklyn, N.Y.

W. A. COVERT & CO., Produce Commission Merchants, No. 68 Pearl Street, New York. Quick sales and prompt returns. Send for our weekly Prices-current and Marking Plate.

The Herald of Health

Sept., Oct., Nov., and Dec. numbers free to new subscribers for 1875, who send in their names immediately.

The September number, among other able articles, contains the following of great interest:

- Reform in Child Education.**
- The October number contains:
- The Building of a Good Brain.**
- Also:
- Headaches, How to Avoid Them.**
- MALADIES CAUSED BY BOOTS AND SHOES.**
- Also, Cramping the Hair; Varicose Veins; Salt Rheum; Diet for Lean Folks; How to stop the Spread of Typhoid Fever; Gloomy Feelings; Insanity; Dandruff; Dyeing the Hair; Baldness; Bad Breath; Periodic Drunkenness; Funny Poems; Perils of Weakness; Girls' Rowing Match; Clean Water and Cow's Health; Care of the Eyes, etc., etc.
- The November number contains:

The Chimoloon,

with illustrations and directions for making this new and healthful article of ladies' under-clothing—and 50 other excellent articles.

The December number will contain:

KINGS AND SLAVES OF BUSINESS,
By JAMES PARTON.

Stair Climbing and Health,
By DR. GEO. E. SMITH.

THE TOOTH-ACHE,
GEO. SEXTON, M. D.

TOBACCO.

A nasty, wicked, filthy weed, which does not meet a single need. Etc.

Mt. Holyoke Female Seminary and its Health Methods; Chats on Health with Children; Dry Mouth; Hints on Fevers, Natural Method of Treating; Diet for the Constipated; Antibilious Pills; When to Marry; Freckles; Lumbago; Falling Sight; Rupture; False Hair; Pimples; Pain in the Stomach; Consumption, etc., etc.

In the January number we shall commence a series of articles on

Over-Work and Physiological Bankruptcy, and one on

Care of the Liver,

and in other respects make it very valuable.

The HERALD OF HEALTH, says the *Scientific American*, contains more sensible articles than any magazine that comes to our sanctum.

Terms, \$2.00 a year, including your choice of the following

- BOOK PREMIUMS:**
- 1. The Complete Works of Shakespeare,** in one large volume, with good type and paper, of over 1000 pages, and 35 illustrations. The most remarkable offer of cheapness we have any knowledge of.
 - 2. Robinson Crusoe.** In one beautiful volume, bound in cloth, gilt edges, and over 600 pages. Every child will be delighted with this offer.
 - 3. How to Educate Yourself.** By GEO. CARY EGGLESTON.
 - 4. Manual of Etiquette.** By DAISY EYEBRIGHT.

We will send the HERALD OF HEALTH and all the above book premiums, post-paid, for \$3.50. Cheaper than wholesale.

NOTICE.—In all cases send 10 cents additional for prepayment of postage. Samples 15 cents.

CLUBBING RATES.—We will send the HERALD OF HEALTH and any \$4 magazine or paper for \$5.35, including one premium and postage.—The HERALD OF HEALTH, Premium, and *New York Tribune*, for \$3.60, postage paid. *American Agriculturist* and one premium, \$3.20, post-paid.

Address **WOOD & HOLBROOK,**
13 & 15 Laight St., New York.

Eating for Strength.

This work, just ready, is a guide to eating, showing how to feed one's self or children, so as to get the best physical development. It is 4 books in one—1st, The Science of Eating. 2nd, Recipes for making healthy food. 3d, Multitudinous recipes for wholesome drinks. 4th, 200 questions answered. Price, by mail, \$1.00, or with HERALD OF HEALTH \$2.50.

NOTE.—Be particular and state what premiums are wanted.

Hygienic Temperance Hotel,
13 & 15 Laight Street.

This well-known house is convenient of access from all parts of the city, six lines of horse cars passing near the door. The table is supplied with the best kinds of food, healthfully prepared, special attention being paid to breads, fruits, luscious foods, vegetables, etc. This house is noted for its pleasant parlors, and the cheerful, home-like feeling which prevails. Connected with the Hotel are Turkish Baths, Electric Baths, etc. Circulars free.

WOOD & HOLBROOK, Proprietors,

AMERICAN AGRICULTURIST. ORANGE JUDD COMPANY, Publishers, 245 Broadway, N. Y. ANNUAL SUBSCRIPTION Terms (always in advance) \$1.50 each for less than four copies: Four to nine copies, \$1.25 each: Ten to nineteen copies, \$1.20 each: Twenty copies and upward, \$1 each. 10 cents extra must be forwarded with each subscription, for prepayment of postage for 1875. Papers are addressed to each name. Either English or German Edition, at these prices.

Light Work and Good Pay FOR DECEMBER. READ OUR Premium List.

New Things, Good Things, Useful Things,

That can be obtained without money and with a little effort by

ANYBODY.

The Publishers of the American Agriculturist present their friends and readers with their Premium List for 1875, full of good things. The experience of many years has taught them that such offers as are here made, of very large returns for a very little labor, never fail to be highly appreciated.

Now, reader, here is something for You. Look over the attractive List of Premiums, which you will find in third column of this page. There are many things among these that you would like to possess without having to pay the money for them. Here are Pocket Microscopes, Gold Pens, Revolving Pencils, Silver-Plated Ware, Knives and Forks, Pocket Knives, Beautiful Toys for the Children, Melodeons, Pianos, Sewing Machines, Knitting Machines, Books, etc., etc., etc. You have only to make your choice, and then take hold of this pleasant work of getting a club of subscribers sufficient to obtain it. More than Fifteen Thousand Men, Women, and Children, in almost all stations and pursuits, have successfully done this, and at least fifteen thousand may do it now. You may as well be one of the fortunate ones, as anybody

else. It only needs a little enterprise and the will—with the will there will be a way. And there can be no better time than now. There is room in every neighborhood for several premium clubs. Everybody ought to have the paper; its plain, practical information will put money in most people's pockets, and save multitudes from swindlers, and from unprofitable investments of funds and time. So while you are aiding to push the paper into the people's hands, you are engaged in "doing Good as well as in Making Money."

The American Agriculturist is one of the best papers to canvass for in the world. Its many beautiful illustrations, its interesting and instructive reading matter, its Household and Boys and Girls' Departments, its intrinsic value in every way, secure hosts of friends wherever it is seen and known. Read five extracts as specimens from many hundreds of persons who have received our Premiums.

"June 1, 1874.

"I am very much pleased with the premiums, [Dictionary and Gun], and could sell them now at a fair price, but can't think of parting with either, although I am not much of a hunter. My watch that I received over two years ago, is an excellent time-keeper. I feel encouraged to do more than ever for the Agriculturist, if I should live next year."

"June 26, 1874.

"Premium [Pocket Rifle] received. Thanks. It is beautiful."

"June 24, 1874.

"Please accept thanks for Carver and Fork, which you sent me as Premium for getting a club to American Agriculturist. I find them as represented—genuine articles."

"October 27, 1874.

"I received the Premium [Braeket Saw] on the 24th. I am very much pleased with it, and will send names for the Premium No. 25."

"October 31, 1874.

"I desire to acknowledge the receipt by to-day's express of your magnificent Premiums, Nos. 2 and 6—a splendid Ice-Pitcher and one dozen Teaspoons—and which I have every reason to believe are fully equal to your representation (the best triple-plate). With thanks for your promptness, I remain yours truly."

Now, what has been done by thousands to their great profit and delight, You too may do. TRY IT.

Explanatory Notes.

N. B.

Read and carefully Note the following Items: (a) All subscribers sent by one person count, though from several different Post-offices. But... (b) Tell us with each name or list of names sent, that it is for a premium... (c) Send the names as fast as obtained, that the subscribers may begin to receive the paper at once. You can have any time you wish up to next July, to complete your list... (d) Send the exact money with each list of names, so that there may be no confusion of money accounts... (e) Old and new subscribers all count in premium clubs, but a portion, at least, should be new names; it is partly to get these that we offer premiums to canvassers... (f) Spe-

cimen Numbers, etc., will be supplied free, as needed by canvassers, but they should be used carefully and economically, and where they will tell... (g) Remit money in Checks on New York Banks or Bankers, payable to order of Orange Judd Company, or send Post-office Money Orders. If neither of these is obtainable, Register Money Letters, affixing stamps both for the postage and registry; put in the money and seal the letter in the presence of the Post-master, and take his receipt for it. Money sent in any of the above ways is at our risk; otherwise it is not.

Table of Premiums.

[In the following table is given the price of each article, and the number of subscribers required to get it free, at the regular rates of \$1.50 a year, and also at the club rates of \$1 a year.] Descriptive List sent Free to applicants.

Table of Premiums and Terms For Volume 34—(1875). BEGINNING NOW. Open to all—No Competition. Table with columns: No., Names of Premium Articles, Price of Premiums, Number of Subscribers required at \$1.50, Number of Subscribers required at \$1.

Every Premium article is new and of the very best manufacture. No charge is made for packing or boxing any article in our Premium List. The Premiums, Nos. 12 to 18, 22 to 26, 29 and 30, 38 to 43, and 59 to 90, inclusive, will each be delivered FREE of all charges, by mail or express (at the Post-office or express office nearest the recipient) to any place in the United States or Territories.—The other articles cost the recipient only the freight after leaving the manufactory of each, by any conveyance desired. See note on "Supplement," next page.

An Illustrated Supplement

containing full descriptions of all our Premiums will be sent *free* to all applicants. We have not room here for the Descriptive List. We ask each of our **Old Readers** to kindly call attention to this fact, and either to raise a club of subscribers, and secure one of these useful and valuable Premiums for himself, or put some friend or neighbor in the way of doing the same. It is

Light Work for Good Pay.

Practical Floriculture.

A Guide to the Successful Propagation and Cultivation of Florists' Plants.

By **PETER HENDERSON,**

Author of "Gardening for Profit."

Beautifully Illustrated. Price, Post-paid, \$1.50.

In this work, which has every where become so deservedly popular, not only is the whole "art and mystery" of propagation explained, but the reader is taught how to plant and grow the plants after they have been propagated. The work is not one for florists and gardeners only, but the amateur's wants are constantly kept in mind, and we have a very complete treatise on the cultivation of flowers under glass, or in the open air, suited to those who grow flowers for pleasure as well as those who make them a matter of trade. The work is characterized by the same radical common sense that marked the author's "Gardening for Profit," and it holds a high place in the estimation of lovers of floriculture. The new edition has been thoroughly revised by the author, and much enlarged by the addition of valuable matter.

The following are a few of the subjects embraced in the latest edition:

Laying out Flower Garden and Lawn; Designs for Grounds and for Greenhouses; Soils for Potting; Cold Frames; Hot-Beds; Greenhouses Attached to Dwellings; Modes of Heating; Propagation of Plants by Seeds and by Cuttings; Culture of the Rose and Tuberoses; Growing of Winter-flowering Plants; Construction of Bouquets, Baskets, etc.; Parlor and Window-Gardening; Wardian-Cases and Ferneries; Insects; What Flowers Grow in the Shade; Culture of Grape-Vines under Glass; The Profits of Floriculture; How to Become a Florist, etc., etc.

Play and Profit IN MY GARDEN.

By **E. P. ROE,**

Author of "Barriers Burned Away," etc.

NOTICES BY THE PRESS.

The author takes us to his garden on the rocky hill-sides in the vicinity of West Point and shows us how out of it, after four years' experience, he evoked a profit of \$1,000, and this while carrying on pastoral and literary labors. . . . It is very rare that so much literary taste and skill are mated to so much agricultural experience and practical good sense. —*Harper's Magazine.*

This book is as poetical as it is practical. Still he is no dreamer. He goes into every essential detail with as much minuteness and precision as if he were writing a manual for the practical farmer. Indeed few works professedly devoted to agriculture give more sound and valuable information on the secret of winning golden harvests from the soil than this brief idyllic sketch. —*N. Y. Tribune.*

A very charming book, not only by reason of its pleasant style, but for its quiet refined humor and fund of really useful information on the subject of gardening. —*Boston Gazette.* It deserves to stand side by side with "My Summer in a Garden." —*Christian Register.*

A fresh, lively work. —*N. Y. Observer.* One reads without weariness and learns much of practical value. —*Chicago Evening Journal.*

Full of information. Explains just what the reader wishes to know. We most heartily commend it. —*Providence Evening Press.*

A chatty, sensible, profitable book. —*Cleveland Herald.* The book gives much valuable information, and gives it in the pleasantest manner imaginable. —*Detroit Daily Union.*

Price, Post-paid - - - - \$1.50

Either of the above books sent post-paid on receipt of price, by

ORANGE JUDD COMPANY,
245 BROADWAY, NEW YORK.

Standard Architectural Books for Carpenters and Builders.



Hussey's National Cottage Architecture; or, Homes for Every One.—With Designs, Plans, Details, Specifications, and Cost; with Working Scale. Drawings complete, so that Houses may be built direct from the book. Adapted to the popular demand for practical, handsome, and economical homes. Royal Quarto. Six Dollars, post-paid.

Atwood's Country and Suburban Houses.—Illustrated with about 150 engravings. Hints and Suggestions as to the General Principles of House-building, Style, Cost, Location, etc. Post-paid, \$1.50.

Monckton's National Stair-BUILDER.—Is a complete work on Stair-Building and Hand-Railing. Fully explained and illustrated by large scale diagrams, in two colors, with designs for Staircases, Newels, Balusters, and Hand-Rails. Royal Quarto. Post-paid, \$6.00.

Monckton's National Carpenter and Joiner.—A complete work, covering the whole science of Carpentry, Joinery, Roofing, Framing, etc., fully explained and illustrated by large scale diagrams in two colors. Royal Quarto. Post-paid, \$6.00.



Woodward's National Architect.—1,000 Designs, Plans, and Details for Country, Suburban, and Village Houses; with Perspective Views, Front and Side Elevations, Sections, Full Detail Drawings, Specifications, and Estimates. Also, Detail Drawings to Working Scale, of Brackets, Cornices, French Roofs, Sectional and Framing Plans of French Roofs, Dormer-Windows for French Roofs, Bay-Windows, Verandas, Porches, Plaster Finish, Cornices, Ceilings, Hard-wood Mantels, and all that is required by a Builder to design, specify, erect, and finish in the most approved style. One superb quarto volume. Post-paid, \$12.00

ORANGE JUDD COMPANY, Publishers, 245 Broadway, New York.

Woodward's Cottages and Farm Houses.—188 Designs and Plans of low-priced Cottages, Farm Houses, and Out-Buildings. Post-paid, \$1.50.

Woodward's Suburban and Country Houses.—70 Designs and Plans, and numerous examples of the French Roof. Post-paid, \$1.50.



Woodward's Country Homes.—150 Designs and Plans, with Description of the Manner of Constructing Balloon Frames. Post-paid, \$1.50.

Woodward's Graperies and Horticultural Buildings.—Designs and Plans of Hot-Beds, Cold-Pits, Propagating Houses, Forcing Houses, Hot and Cold Graperies, Green Houses, Conservatories, Orchard Houses, etc., with the various modes of Ventilating and Heating. Post-paid, \$1.50.

Wheeler's Rural Homes.—Houses suited to Country Life. Post-paid, \$2.00.

Wheeler's Homes for the People.—100 Original Designs, with full Descriptions, and Constructive and Miscellaneous Details. Post-paid, \$3.00.

Harney's Barns, Out-Buildings, and Fences.—Containing Designs and Plans of Stables, Farm-Barns, Out-Buildings, Gates, Gateways, Fences, Stable Fittings and Furniture, with nearly 200 Illustrations. Royal quarto. Post-paid, \$6.00.

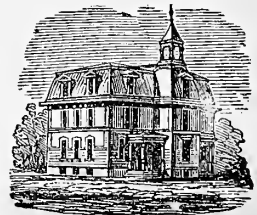

Eveleth's School-house Architecture.—A new and original work, containing Seventeen Designs for School-houses, Sixty-seven Plates with Perspectives, Elevations, Plans, Sections, Details, Specifications all drawn to working scale, with methods of Heating and Ventilation. Large quarto. Post-paid, \$6.00.

Copley's Plain and Ornamental Alphabets.—Giving examples in all styles, together with Maps, Titles, Borders, Meridians, Ciphers, Monograms, Flourishes, etc., adapted for the practical use of Surveyors, Civil Engineers, Draughtsmen, Architects, Sign Painters, Schools, etc. Post-paid, \$3.00.

Good Books

ON

Architecture.

DETAIL, COTTAGE, AND CONSTRUCTIVE ARCHITECTURE,

Containing 76 FULL PLATES, 20 plates more than before offered in a similar work for Ten Dollars.

Published under the direction of A. J. BICKNELL.

Showing a great variety of Designs for Cornices, Brackets, Windows and Window Caps, Doors, Piazzas, Porches, Bay and Dormer Windows, Observatories, Towers, Chimney Tops, Balconies, Canopies, Scrolls, Gable and Saved Ornaments, Fenees, Stairs, Newcls, Architraves, Mantels, Plaster Finish, etc., etc.; including Forty-five Perspectives, Elevations and Plans of Modern Designs for Cottages with Details, and Eighteen Elevations of Summer Houses, Villas, Seaside Cottages, and Country Houses, together with Fourteen Designs for Street and Store Fronts, with Inside Finish for Stores and Banks; also, Framing for Dwellings, Barns, Exhibition Buildings, Roofs, Bridges, etc., etc., making in all a Practical Book for Architects, Builders, Carpenters, and all who contemplate Building or Remodeling Wood, Stone, or Brick Buildings. One Large Quarto Volume, sent Free by Mail or Express, on receipt of Price.....\$10.00.

CARPENTERS' and BUILDERS' ASSISTANT,

And Wood Workers' Guide,

By L. D. GOULD, Architect and Praetical Builder.

Containing 23 Plates, fully described; also, tables of the strength of materials; technical terms used by carpenters, etc., etc. This work is intended to combine all the knowledge the workman requires to construct any design in carpentry, by a new and easy system of lines, reducing the science of construction to an agreeable and pleasant occupation, rather than an unpleasant task. One Svo. volume, bound in cloth. Price.....\$3.00.

ARCHITECTURE.

By CUMMINGS & MILLER.

A Practical Book on Architectural Details; containing over One Thousand Designs and Illustrations, showing the manner of constructing Cornices, Doorways, Porches, Windows, Verandas, Railings, French Roofs, Observatories, Piazzas, Bay-Windows, Cut-Stone Work, various styles of Modern Finish, and Street Fronts of Houses, Stores, etc., etc. One Large Quarto Volume. Price, post-paid....\$10.00.

Loth's Practical Stair-BUILDER.

A complete Treatise on the Art of Building Stairs and Hand-Rails. Designed for Carpenters, Builders, and Stair-Builders. Illustrated with Thirty Original Plates. By C. EDWARD LOTH, Professional Stair-BUILDER. One large Quarto Volume. Bound in Cloth. Price.....\$10.00.

Address

ORANGE JUDD COMPANY,
245 BROADWAY, NEW YORK.



Every Farmer,
Every Breeder,
Every Horse-Owner
His Own Farrier.
Send for circulars to
GOODENOUGH
HORSE-SHOE,
Box 3,044, P. O., N. Y.
Offices: 34 and 36
Elizabeth Street.

FANCIER'S JOURNAL A Weekly devoted to Fowls, Pigeons, Rabbits, Dogs, Song Birds, etc. Send stamp for Specimen Copy. JOS. M. WADE, Philadelphia, Pa.

200 PIANOS AND ORGANS,

New and second-hand, of first-class makers, will be sold at lower prices for cash, or on installments, or for rent, in city or country, during this month, by Horace Waters & Son, No. 481 Broadway, than ever before offered in New York. A specialty: Pianos and Organs to let until the rent money pays the price of the instrument. Illustrated catalogues mailed. A large discount to Teachers, Ministers, Churches, Schools, Lodges, etc.

THE PATENT

ARION

PIANO-FORTE

Excels all others in Tone and Durability, and in Elegance of Finish they are Unsurpassed.

These Pianos are used exclusively in the New York Conservatory of Music, and are recommended by the Profession and the Press throughout the United States.

Before purchasing, write for Illustrated Pamphlet, and mention the *Agriculturist*.

ARION PIANO-FORTE CO.,
No. 5 East 14th Street, New York City.

Established 1858.



TRADE MARK PATENTED.

The best and cheapest Paint in the world for Iron, Tin or Wood. For sale by the Trade everywhere. PRINCE'S METALLIC PAINT CO., Manufacturers, 96 Cedar St., New York. CAUTION.—Purchasers and consumers are cautioned against imitations of our METALLIC PAINT. All genuine PRINCE'S METALLIC PAINT will bear our name and trade mark on each and every package. Send for a circular.



BUILDING FELT.

This water-proof material, resembling fine leather, is for outside work (no tar substances used) and inside, instead of plaster. Felt carpets, etc. Send for circular and samples.

C. J. FAY, Camden, N. J.

GENUINE Peruvian Guano. In Large or Small Quantities.

Circulars, containing testimonials, referenees, and full particulars, mailed free on application to

R. BALCAZAR,
P. O. Box 129. No. 53 Beaver Street, New York.

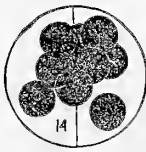

MAYNARD'S BREECH-LOADING Combination Rifles and Shot-Guns.

CENTRAL FIRE Reloading-Capped Cartridges. Send for Price-list with Target Illustrations. Mass. Arms Co., Chicopee Falls.

Essex Pigs.

I have very choice, pure-bred Essex Pigs of different ages that I am prepared to sell at reasonable rates. It is a good time to buy. Orders promptly filled. Address JOSEPH HARRIS, Moreton Farm, Rochester, N. Y.

MANMOTH BRONZE TURKEY, and all leading kinds of Poultry. Also Magie Hogs and Cotswold Sheep. Send for Circular Free. L. L. REED, Auburn, Geauga Co., O.

Pekin Ducks, illustrated in Sep. *Agriculturist*. Bronze Turkeys, descended from a pair weighing 62 lbs. Jersey Cattle, A. I. C. C. R., and Cotswolds, at low prices. Address W. CLIFT, Mystic Bridge, Ct.

COTSWOLD SHEEP.

For pure-bred Cotswold Sheep of the choicest kind address JOSEPH HARRIS, Moreton Farm, Rochester, N. Y.

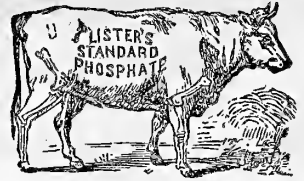

CELEBRATED FERTILIZERS.

Pure Bone Superphosphate of Lime. GROUND BONE, BONE MEAL, BONE FLOUR:

The large annual increase of the sales of these Standard Fertilizers is the best proof of their merits. Their freedom from adulteration, with every particle available for fertilizing, and the low price at which they are sold make it for the interest of every practical farmer to give them a fair trial.

LISTER BROTHERS,

New York Office, 159 Front St. Factory, Newark, N. J. Farmers and Dealers are invited to send for Circular.

AMERICAN AGRICULTURIST.



PATENT DEPARTMENT.

IMPORTANT TO INVENTORS.

American Agriculturist PATENT DEPARTMENT

In compliance with the request of numerous inventors, we have organized a

PATENT DEPARTMENT

in connection with this office for the transaction of all business connected with

Securing Patents

in the United States and foreign countries. The character for

Reliability

which has been maintained by the AMERICAN AGRICULTURIST for more than thirty years will be carefully guarded in this as in other departments.

All Inventors

desirous of procuring patents at moderate cost are invited to forward (express prepaid) a model of their invention, with a brief description of its working. The model should not exceed one cubic foot in dimension. Upon receipt of model an opinion as to patentability will be given free of charge.

Preliminary Examination

at the Patent Office, to determine patentability, will be promptly made for a fee of \$5.

Litigation of Patents.

The services of the best counsel have been secured to prosecute or protect before the U. S. Courts and the Patent Office the claims of those intrusting their business to this agency.

Specifications, drawings, engravings, models, and all other appliances furnished at moderate prices.

In all dealings with this Department inventors may depend upon promptness, fidelity to their interests, and the best services which can be rendered by thorough experts. For full particulars, address

AMERICAN AGRICULTURIST PATENT DEPARTMENT ORANGE JUDD COMPANY, 245 Broadway, New York.

PATENTS

PATENTS

Rare & Beautiful Flowers
AND
CHOICE VEGETABLES.

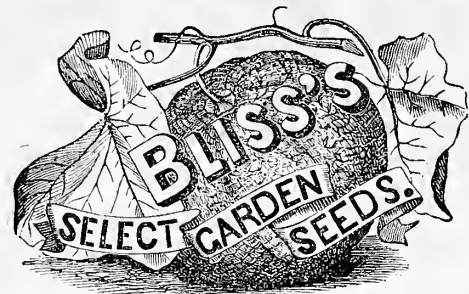

The Twentieth Annual Edition of our celebrated Seed Catalogue and Amateur's Guide to the Flower and Kitchen Garden, containing upwards of 200 pages, including several hundred finely executed engravings of favorite flowers and vegetables, and a beautifully colored chromo, will be ready early in January, and mailed to all applicants upon receipt of 25 cents. An edition elegantly bound in cloth \$1.00.

BLISS'S GARDENER'S ALMANAC and **Abridged Catalogue** contains upwards of 100 pages, and embraces a monthly calendar of operations and a price-list of all the leading **Garden, Field, and Flower Seeds**, with brief directions for their culture. A copy will be mailed to all applicants inclosing two three-cent stamps.

B. K. BLISS & SON,
31 Barclay Street,
P. O. Box 5712. New York City.

CHOICE SEEDS.

Carefully grown from the finest stocks for critical buyers. Garden Manual, full of practical hints and worth ten times its cost, sent for two stamps. Ready Dec. 1st. Special rates to early buyers.

J. B. ROOT, Seed Grower, Rockford, Ills.

GRAPE VINES,

Grown especially for the Trade, very fine, and at low prices. **CONCORD, HARTFORD PROLIFIC** and **MARTHA**, in large quantities.

A. HANCE & SON Nurserymen & Florists,
Red Bank, N. J.



My ANNUAL CATALOGUE of VEGETABLE and FLOWER SEED for 1875, will be sent free to all who apply; customers of last season need not write for it. On my several seed farms I raise one hundred and fifty varieties, and also import from growers in Europe their choicest kinds. In my Catalogue will be found several valuable new varieties of vegetables, I having made this department a specialty for many years. I would particularly invite the patronage of Market Gardeners, and all others who are especially desirous to have their seed pure and fresh, and of the very best strain. All seeds sent out from my establishment are covered by three warrants, as given in my Catalogue.

JAMES J. H. GREGORY, Marblehead, Mass.

- Trees, 500,000 Apple, Pear, etc.
 - 100,000 Peach Trees.
 - 100,000 Grape Vines.
 - 50,000 Currant Bushes.
 - Vines, 500,000 Sweet Chestnut Trees.
 - 10,000 Spanish
 - SHRUBS, A CHESTNUT CIRCULAR FREE.
 - 1,000,000 Evergreens, best in market.
 - 200,000 Deciduous Trees and Shrubs.
 - 50,000 Magnolia Acuminati, one year, fine.
 - Plants, 10,000 Tulip Trees, 6 to 12 feet.
 - 2,000 Weeping Mountain Ash.
 - 50,000 Rose Bushes.
 - Etc. A new Descriptive Catalogue and Wholesale List free.
- 21st Year. 40 Acres. 11 Greenhouses.
Address, **STORRS, HARRISON & CO.,**
Painesville, Lake Co., Ohio.

GRAPE-VINES.

LARGEST STOCK IN AMERICA. Extra quality Reduced Prices. **T. S. HUBBARD,** Fredonia, N. Y.



Is the cheapest and best illustrated weekly paper published. Every number contains from 10 to 15 original engravings of new machinery, novel inventions, Bridges, Engineering works, Architecture, improved Farm Implements, and every new discovery in Chemistry. The **SCIENTIFIC AMERICAN** has been published weekly, for 30 years, and stands foremost of all industrial papers, and has a larger circulation than any other paper of its kind in the world. A year's numbers contain 832 pages and several hundred engravings. Thousands of volumes are preserved for binding and reference. The practical receipts are well worth ten times the subscription price. Terms, \$3.20 a year by mail, including postage. Specimens sent free, May be had of all News Dealers.

PATENTS

AMERICAN & EUROPEAN.

Established, 1846.

MUNN & CO.,

Editors of the **SCIENTIFIC AMERICAN,**

Continue to give opinions in regard to the Novelty of Inventions, Free of Charge; Make Special Examinations at the Patent Office; Prepare Specifications, Drawings, Caveats, Assignments; and prosecute Applications for Letters Patent at Washington, and procure Patents in Canada and in all European Countries. They give special attention to the prosecution of Rejected cases, Appeals, Extensions and Interferences. A special notice is made in the **SCIENTIFIC AMERICAN** of all Inventions Patented through this Agency, with the name and residence of the Patentee. Patents are often sold in part or whole, to persons attracted to the invention by such notice. Send for Pamphlet, 110 pages, containing laws and full directions for obtaining Patents. Address for the Paper or concerning Patents,

MUNN & CO., 37 Park Row, New York.
Branch Office, cor. F and 7th Sts., Washington, D. C.

The Little Corporal.

AN ILLUSTRATED MAGAZINE FOR BOYS AND GIRLS.

This magazine has now been nearly ten years before the public, and has secured for itself the highest reputation, for the excellence of its reading matter and the beauty of its illustrations.

Its conductors aim to provide in each number wholesome entertainment for the **Little Folks, Young Folks, and Old Folks with young hearts.** Terms \$1.50 a year, Postage Paid. Clubs of 5 names at one time, \$1.10 each Postage Paid. Specimen numbers 10 cents.

Two Months Free! All new subscribers for 1875 whose names are sent during this month will receive the remaining numbers of this year free! *Beautiful Premiums for Clubs!*

Address, **JOHN E. MILLER, Publisher, Chicago, Ills.**

AMERICAN SUNDAY WORKER

a S. S. Teacher's Monthly—6th Year—International Lessons. \$1.50 a year; Club rates low. Specimen 15 cts. **J. W. McINTYRE,** Publisher, No. 4 South 5th St., St. Louis.

GAS LIGHT FOR ALL.

Every Household can be supplied with a beautiful illuminating Gas by

THE KEYSTONE SAFETY GAS MACHINE.

It is simple in construction, safe in operation, and certain in results. For Villages, Churches, Rural Homes, Institutions, etc., the Keystone apparatus affords the most perfect means of illumination yet discovered.

Pamphlets and full information on application.
The Keystone Safety Gas Machine Co.,
J. B. WILSON, Pres. C. H. BAKER, Sec.
717 Sanson St., Philadelphia.
110 Liberty St., New York.

OUR
Illustrated Catalogues
FOR 1875 OF
EVERYTHING
FOR THE
GARDEN!
(Seeds! Plants!)
Implements, Fertilizers, etc.)
Numbering 175 pages and containing five beautiful colored plates, mailed on receipt of 50 cents.
Catalogue, without plates, free to all.
Peter Henderson & Co.
35 Cortlandt St.,
NEW YORK.

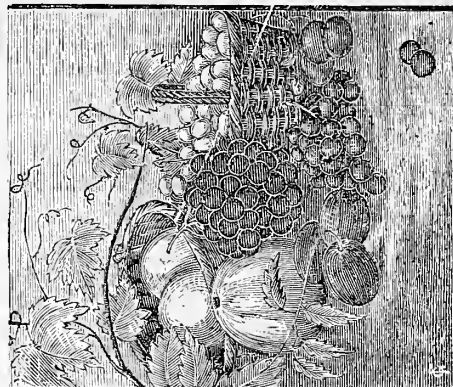

PURDY'S FRUIT CHROMO.

\$1.25 gets the **Fruit Recorder and Cottage Gardener**, last three months of this year, and for 1875, and above beautiful Chromo, or 50 cts. gets the paper last 3 months of this year and the Chromo. We have now sent out 12,000 of this fine fruit-piece, and have not heard one complaint. It is pronounced by all the finest Chromo ever sent out by any publisher. This paper is strictly devoted to fruit-growing and home's adornment. Specimen copies sent on application. Large cash commission to club agents. **Small Fruit Instructor**, a 64 page pamphlet, telling how to plant and grow all kinds of small fruit abundantly. Address **A. M. PURDY, Rochester, N. Y.**

The Home Florist
An elegant, comprehensive treatise on Open Air, Window and Conservatory Floriculture. 200 different Seed-grown, Bulbous and other plants, including Roses, are treated on, also Propagation, Amateur's Conservatories, Work for Each Week of the Year, etc. 330 practical articles; 60 instructive engravings. The matter is original, fresh and vigorous, suited to all seasons. Authors, Editors and Florists of high standing commend it. Now ready, price 30 cts. post paid.
Address, **LONG BROS., BUFFALO, N. Y.**
FREE An Illustrated Catalogue of Floricultural stock, for 1875, to Postal Card or other applicants, also extended description of HOME FLORIST. **SEND**

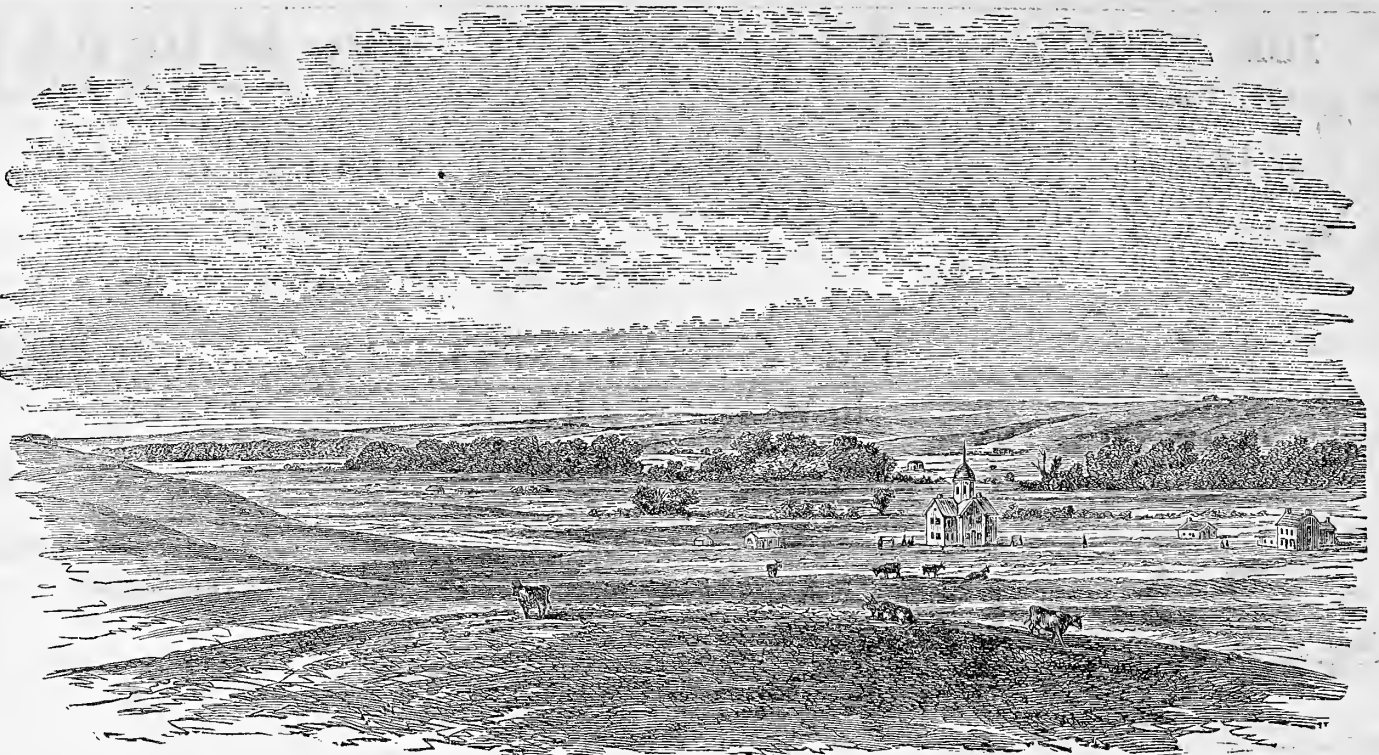

DOANE COLLEGE, IN SOUTH PART OF CRETE, NEB.

IF YOU WANT A FARM OR HOME,
 YOU SHOULD BUY OF THE
BURLINGTON AND MISSOURI RIVER RAILROAD CO.
 IN IOWA OR NEBRASKA.)

BECAUSE—Their prices are low, ranging for the best land from Three to Ten Dollars per acre.
BECAUSE—No payments are required of the purchaser for four years, except interest at six per cent.
BECAUSE—After the fourth year only one seventh of the principal is payable annually till the whole is paid.
BECAUSE—You are not required to go into a wilderness, these being well-settled States, the population of which is rapidly increasing.
BECAUSE—The mildness of the climate and fertility of the soil is such that the settler can pay for his farm from the products raised upon it long before the time when the principal becomes due.
BECAUSE—Failure of crops from drouth is unknown.
BECAUSE—Large allowances are made upon fare and freight, thus giving low rates on both to purchasers of this Company's lands.

AND YOU SHOULD BUY THIS YEAR.

BECAUSE—Purchasers of our lands in Nebraska during 1874 who cultivate one-half their land within two years from their purchase are allowed a reduction of twenty per cent on its price. **LARGE DISCOUNTS** also, FOR CASH, within One, Two, or Five Years.

Send for Circulars, with full information on all points, to

GEO. S. HARRIS, Land Commissioner,

At Lincoln, Nebraska, for land in Nebraska. At Burlington, Iowa, for land in Iowa.

Or to **W. D. COWLES**, General Agent, 317 Broadway, New York.

JAS. R. WOOD, General Agent, 59 Clark St., Chicago, Ill.

THE AMERICAN DAIRY SALT COMPANY,
 SOLE MANUFACTURERS OF THE
ONONDAGA FACTORY FILLED
DAIRY & TABLE SALT,
 AT SYRACUSE, N. Y.,

Respectfully call the attention of Dairymen and others to the quality of the salt now being manufactured by them. Having for many years past been engaged in perfecting the various processes for the manufacture of this salt, and by adopting the best modes and machinery for the purpose, they feel warranted in saying to the consumer that the article now produced is superior to any other either of foreign or domestic production. The following is a correct analysis of our Salt, and also of the celebrated Ashton's English Salt, made by Chas. A. Goessmann, Ph. D., Professor of Chemistry in the Massachusetts Agricultural College at Amherst, Mass:

	Ashton Salt.	Onondaga Factory Filled.
Chloride of Sodium.....	97.45	98.25
Sulphate of Lime.....	1.43	0.91
Sulphate of Magnesia.....	0.05	.06
Chloride of Magnesia.....	0.06	.00
Sulphate of Soda.....	.00	.03
Insoluble matter.....	.05	.12
Water.....	.76	.60
	100.00	100.00

Circulars in regard to various tests made with this salt in comparison with the best foreign article, also certificates from a large number of the best dairies in the State as to its quality, may be had on application to **J. W. BARKER**, Secretary, Syracuse, N. Y., to whom orders for salt may also be addressed.

It is also for sale by the Agents of the Company in principal Western Lake Ports, by **SR. JOHN & AVERY**, 101 & 103 Broad St., New York; **ROBERT GREEN**, 109 Pier, Albany, N. Y., and by Salt Dealers generally throughout the State of New York. Inquire for **Onondaga Factory Filled Dairy Salt**. **J. W. BARKER**, Pres. & Sec'y, Syracuse, N. Y. **THOS. MOLLOY**, Treas.

FANCIER'S JOURNAL A Weekly devoted to **Fowls, Pigeons, Rabbits, Dogs, Song Birds, etc.** Send stamp for Specimen Copy. **JOS. M. WADE**, Philadelphia, Pa.

CLAVELACK College and Hudson River Inst., at Clavelack, N. Y. Opens Sept. 7. **ALONZO FLACK**, Ph. D., Pres.

THE NEAT HOUSEKEEPERS' STOVE DRESSING.

NO DUST! NO SMELL!
 Always soft and ready for use without a dish.
 It will do more work with less labor and expense, and give a more elegant and lasting lustre than any Stove Polish ever produced. *A stone can be dressed on delicate carpet without soiling it.* Manufactured only by
B. F. BROWN & CO., Boston, Mass.

CANVASSERS
 POSITIVELY make enough from now till January to keep them a year. Entirely new features. Immense success. Be quick. Send for valuable specimens (free) to
T. E. MOORE, Publisher, No. 11 Dey St., New York.

GLASS CARDS Red, Blue, White, Clear & Transparent. Your Name Beautifully printed in GOLD! on 1 doz. for 50c. post pd.; 3 doz. \$1. Must have agents everywhere. Outfits 25c. Samples 3c. **P. K. SMITH**, Bangor, Maine.

AGENTS LOOK! \$12 a day made selling Scissors, SHARPENERS, and other wares. Sample 25 cts. Catalogue free. **T. J. HASTINGS & CO.**, Worcester, Mass.

CHRISTMAS BELLS FOR 1874. Indispensable to All who Wish to be Happy and Make Others So. Sent Free on receipt of 1 stamp by **ADAMS & CO., Publishers, Boston.**

AGENTS WANTED—Ladies and Gents—To sell our new Holiday goods. Send 25 cts. for samples. **BUFFINGTON & CO.**, East Hampton, Mass.

ALL ABOUT HOT-BEDS. A complete treatise, with many labor-saving hints on other garden topics, in my Garden Manual and Seed Catalogue. Sent for 2 stamps. Free to former patrons without request. Ready Dec. 1. **J. B. ROOT**, Seed Grower, Rockford, Ills.

NIAGARA FIRE INSURANCE COMPANY, 201 Broadway, N.Y.

Capital Stock.....\$500,000
 Cash value of Assets.....\$1,319,933
 Total Liabilities.....60,871
 Net Assets.....\$1,259,062
 Dwellings and Farm Risks a specialty at all our Agencies.
HENRY A. HOWE, President.
P. NOTMAN, V. P. and Sec'y.

THE PENN MUTUAL LIFE INSURANCE COMPANY OF PHILADELPHIA.

ASSETS ACCUMULATED, \$4,427,996.96.
 The Penn is a purely mutual Company. All of its surplus premiums are returned to the members every year. Dividends may be applied to reduce the premium or increase insurance as desired. **SAM'L C. HUEY**, Pres. General and Local Agents wanted in the Middle and Western States. Apply to **H. S. STEPHENS**, Vice Pres., No. 921 Chestnut Street, Philadelphia, Pa.

Lovejoy's New Style GLASS CUTTER And Putty Knife
 Cuts glass better than a diamond. Everybody should have one. Any child can use it. Sent to your address on receipt of 50c. and stamp by **ALVAN L. LOVEJOY**, 229 Washington St., Boston, - - - Mass. Liberal Discount to Wholesale and Retail Dealers.

Cheapest Power—Just patented.—Now in successful operation.—Powell Vertical Tread-Wheel—10 to 30 horse-power. Rights for Sale. **W. F. WELLS**, Gen'l Agent, Cleburne, Texas.
The New P. T. Barnum Coupon Hat. It will pay you to ask your hatter for it. Made by **J. S. FAYERWEATHER & CO.**, Danbury, Conn. Send for descriptive circular.

MUSIC FREE!—Any one enclosing to DEXTER SMITH, Boston City, a newspaper-wraper with their name and address written upon it, and a three-cent stamp affixed, will receive \$3.00 worth of beautiful Songs, Piano Pieces, and Pictures, free!

Send Us Fifteen Cents

and receive **19 pages New MUSIC** by return mail, **19 worth in sheet music form \$3.00.** The **FOLIO**. WHITE, SMITH & CO., BOSTON, MASS.

BRAINARD'S MUSICAL WORLD.

\$10 to \$20 per day can be made canvassing for this popular Musical Monthly. Greatly improved and enlarged—16 pages of choice new music and 20 pages of reading matter in each number. Only \$2.00 a year. Active agents wanted. Sample copies and full particulars sent on receipt of ten cents. Address

S. BRAINARD'S SONS, Publishers, Cleveland, O.

Clarke's

New Method for the Piano-Forte.

Endorsed by the Musical, Educational and general Press, and by Good Teachers, to be beyond all comparison the Best to be had at Book and Music stores.

Sent by Mail, Price, \$3.75.

LEE & WALKER,} 922 Chestnut St. PHILADELPHIA.

ALL FOR ONE DOLLAR.

- Wine, Wife and Song.....by Strauss.
- A happy Circle Gallop.....Strauss.
- La Fille de Madam Angot.....Waltz.
- With Steam, Polka.....Ed. Strauss.
- Let's be Gay, Waltzes.....J. Strauss.
- Regatta Veneziana.....F. Liszt.
- La Bella Louise, Quickstep.....Ruhle.
- Where the Citrons Blossom.....Strauss.
- Who is at my Window.....Osborne.
- Annie Dear.....Abt.

Why throw away money on high-priced Music when you can select from our Catalogue of 700 pieces? Any 20 Half Dime, or 10 of Dime Series, mailed on receipt of One Dollar. Sold by all booksellers, and can be ordered through any newsdealer. Send stamp for Catalogue.

BENJ. W. HITCHCOCK, Publisher, 355 Third Avenue, New York.

THE GREAT MUSIC BOOKS

For Conventions and Singing-Schools are

THE SONG KING.

By R. H. PALMER.

THE JOY.

By P. P. BLISS.

THE SONG ERA.

By F. W. ROOT.

The True Singing-School Text Book.

By A. N. JOHNSON.

Price of each, \$7.50 per Dozen.

Specimen Copy of either, 75 Cents, post-paid, by mail. Published by JOHN CHURCH & CO., Cincinnati, O.

New Church Music Book,

For 1874—1875.

THE LEADER!

By H. R. PALMER, assisted by L. O. EMERSON.

Just issued and ready for sale. Its success already assured. Its price is a return to ante-war Church Book rates, and its contents new, fresh, and cannot fail of winning a hearty endorsement from choir masters—the musical profession and the musical public. Specimen pages free on application.

PRICE \$1.38. \$12.00 PER DOZ.

RIVER OF LIFE.

FOR SABBATH SCHOOLS.

A sale of over 30,000 in less than one year attests the merit of this Book. The Publishers are confident that no better Sabbath School Book has been published in years, and none given such entire satisfaction.

Price 35 cts. B'ds; \$3.60 per doz.; \$30 per 100.

THOMAS'

SACRED QUARTETS and ANTHEMS.

This day published.—Has been many years in preparation and will be welcomed by all the lovers of Mr. Thomas' Sacred Music—and who is not one? As a Quartet Book for Choirs, it will be found indispensable.

Price in Boards, \$2.50. Cloth, \$3.00.

OLIVER DITSON & CO., CHAS. H. DITSON & CO., Boston, 711 B'dway New York.

ADVERTISERS should send to Geo. P. ROWELL & Co., 41 Park Row, N. Y., for their *Eighty-page Pamphlet*, containing lists of 3,000 newspapers and estimates, showing the cost of advertising. Mailed free to all applicants.

THE CHRISTIAN ADVOCATE

For 1875.

NOW READY,

MAGNIFICENT PREMIUM ENGRAVING!!!

REV. DANIEL CURRY, D.D., Editor.

REV. W. H. DE PUY, D.D., Assistant Editor.

The Oldest, Most Widely Circulated, and Most Largely Patronized Methodist Weekly Journal in the World.

While it makes no array of lists of contributors, no religious Journal in the country exceeds it in *The Ability of its Editorials, the Ability and Number of its Correspondents, the Variety and Freshness of its News, or the Number or Utility of its Various Departments.*

It is sought for by the children as well as by adults, and abounds in information fresh, attractive, and useful to persons in every vocation of life. Its great merit as a religious family journal is universally conceded. Notwithstanding the great competition on every side, its circulation is constantly increasing, and now extends into every Christian country, and its subscription list is now the largest of any of the great denominational weeklies.

The Publishers take pleasure in announcing their plans for the ensuing year. The present large circulation of *The Christian Advocate* and the prospective increase in the subscription list, will enable us to continue to furnish it in its enlarged form and at the present low price of \$2.50 per year, while the superior quality of the paper and the excellence of the mechanical work upon it will not be diminished in the least. We will also send the paper to new subscribers from the date of receiving their names to January 1, 1876, for the price of a single year's subscription. In other words, new subscribers for 1875, the volume which opens with January next, will receive the paper for the remainder of the present year free of charge.

The Publishers have also arranged to favor every subscriber to *The Christian Advocate* for 1875 with the most meritorious and valuable free Premium ever offered by any religious weekly to all its subscribers. For this purpose they have purchased of that eminent artist, Mr. A. H. Ritchie, his new, original, and magnificent steel engraving, "MERCY KNOCKING AT THE WICKET GATE," (single copies of which sell at \$5 each), and will send a copy free of charge to every subscriber, old and new.

Concerning the real merit of this splendid engraving, and as illustrations of the great favor which it is receiving from the best judges, we quote the following brief paragraphs from highly appreciative notices (many of them lengthily) received by Mr. Ritchie during the last few weeks:

- From Bishop Simpson: "I am much pleased with both its design and its execution."
- From Rev. Dr. E. O. Haven, Chancellor of Syracuse University: "Mercy Knocking at the Wicket Gate" is not only superior as a work of art, and a great credit to its author on that account, but it is of such a character as to make a pleasing impression on the mind, and to be worthy of a permanent place where it will be often seen. It partakes largely of that which makes a thing 'a joy forever.' I congratulate the artist on his success."
- From Rev. Dr. Leonard Bacon, President of Divinity School of Yale College.—"I have rarely found my susceptibilities so touched by any similar work of art as they have been to-day (Sept. 14, 1874.) by your most exquisite engraving of your own most eloquent picture, 'Mercy Knocking at the Wicket Gate.' You may thank God that He, by giving you grace to make that picture, has made you a preacher of the Gospel to all who, seeing it, can feel the lesson that is in it."
- From Rev. Dr. Cummings, President of Wesleyan University: "The engraving, 'Mercy Knocking at the Wicket Gate,' executed by A. H. Ritchie, is a beautiful work of art. No one can look upon it without being pleased and profited."
- From Rev. Dr. Talmage, Brooklyn: "The engraving, 'Mercy Knocking at the Door,' is worth fifty sermons. How any one can look at it without more tears on his cheek than seems, according to the picture, to have fallen on Mercy's cheek, I know not. Thanks, thanks."
- From Rev. Dr. Fowler, President of the North-western University: "Have seen your new engraving, 'Mercy Knocking at the Wicket Gate,' and like the subject and the work."
- From the Western Christian Advocate, Sept. 23: "It will be found an excellent and snitable picture with which to decorate many houses, and to collectors or all who appreciate the progress of native skill it will be valuable. It is a notable addition to American works."
- From Zion's Herald, Sept. 24: "It is an impressive and eloquent picture, full of pathos and spiritual significance. It makes a perpetual sermon upon the wall."
- From the Baptist Weekly, Sept. 24: "It is engraved in the highest style, and makes one of the finest pictures we have ever seen. The moral effect of such a picture in our homes can hardly be estimated. It is a study so fruitful of religious thought, and so tender in its practical suggestions, that the eye can hardly grow weary in gazing upon it, and the heart can never lose the power of its impression."
- From the Brooklyn Daily Argus, Sept. 14: "It is a beautiful parlor piece."
- From the N. Y. Daily Times, Sept. 12: "The beauty and force of Mr. Ritchie's original picture, and the masterly manner in which he treated this pretty episode from Pilgrim's Progress, were well described at the time, with, we believe, the unanimous accord of the critics. We have only to say that the engraving on steel does full justice to the original, and that it has been completed in the best style of the art."
- From the Sunday-School Times, Philadelphia, Oct. 10: "Mr. Ritchie's new engraving is a beautiful study, executed with rare skill. It is large in size, and exquisite in tone and finish. . . . Lovers of art will be glad to see this picture multiplied. It will find favor in many homes where a critical taste challenges every new introduction."

As under the new postal law publishers must prepay postage, subscribers must remit twenty cents additional for postage. All pastors in the Methodist Episcopal Church are our Agents, and subscriptions for the paper and orders for premiums may be forwarded through them. When agents order premiums for the supply of their localities at one time, we send by express free of charge. When premiums are ordered to be sent by mail, ten cents must be remitted for prepayment of postage.

NELSON & PHILLIPS, Publishers, 805 Broadway, New York.

GREAT DEDUCTION. TEAS and COFFEES
At Wholesale Prices.
 Increased Facilities to Club Organizers.
 Send for New Price-List.
THE GREAT AMERICAN TEA COMPANY,
 (P. O. Box 5643.) 31 and 33 Vesey St., New York.

WOOD, TABER & MORSE,
Eaton, Madison Co., N. Y.
 MANUFACTURERS OF
Steam-Engines,
 Portable, Stationary, and Agricultural.
 Hundreds in use in Shops, Printing Rooms, Mills, Mines, and on Farms and Plantations for Grain Threshing, Food Cooking, for Stock, Cotton Ginning, Sawing, etc. Circulars sent on application.

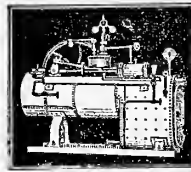

BOGARDUS' PATENT UNIVERSAL ECCENTRIC MILLS,
 For Grinding Bones, Ores, Fire Clay, Guanos, Oil-Cake, Feed, Corn, Corn and Cob, Tobacco, Roots, Salts, Spices, Flax-Seed, Tomatoes, &c., and whatever can not be ground by other Mills. Also, for Paints, Inks, Blacking, &c.
JOHN W. THOMSON, Successor to James Bogardus, Corner of White and Elm Streets, New York.

FOR FALL AND WINTER.
 Horse-Powers, Engines and Threshers. Corn Shellers, Fan Mills, Fodder and Root Cutters. Smut Machines. Grain and Flouring Mills. Steamers and Boilers. Hay and Cotton Presses. Churns, Carts, Wagons, Stump Pullers and Ice Tools.
 Address **R. H. ALLEN & CO.,**
 P. O. Box 376, 189 & 191 Water St., New York City.

CAUTION.
 On account of the popularity of the Wheeler & Wilson Sewing Machines, parties have largely been engaged in purchasing old and second-hand machines of that make, and imposed upon the public by selling them as new machines. The Wheeler & Wilson Company begs to advise the public that any one desiring to buy their second-hand machines can be supplied by that Company direct, on better terms than others can afford them, and be assured of what they are buying. Address
WHEELER & WILSON M'FG CO.,
 625 BROADWAY, NEW YORK.

700 YEARS AMUSEMENT
AMERICAN AMUSEMENT
 A storehouse of fun and profit for the social circle is found in these fifty new games of AMERICAN HISTORY, on sixty cards, in a Patent Box. Price, 75 cents. "These admirably devised games are ingenious, amusing, and instructive."—F. SAVYRE, Librarian of Astor Library, N. Y. "They stand without a rival in the home circle."—PHILIP PHILLIPS, Singer. Also a charming Bible-history pastime: The 60 CARDS OF CHANGING PLAGUES of Egypt; typical of the Hebrew Bondage. By an eminent clergyman. Four games on 40 illustrated cards, 50 cents; or both mailed for \$1.
E. B. TREAT, Pub., 805 B'way, N. Y.

The Young Housekeeper's Friend,
 by Mrs. Cornelius. The best Cook Book and guide for the various duties of the household published. Price \$1.50. Interleaved \$2.25. Sent by mail on receipt of price.
THOMPSON BROWN & CO.,
 Boston, Mass., Publishers.

BOOK AGENTS WANTED
 to sell the **NEW BOOK TELL IT ALL**
 By Mrs. Stenhouse of Salt Lake City, for 25 years the wife of a Mormon High Priest. Introduction by Mrs. Stowe. This story of a woman's experience lays bare the "hidden life," mysteries, secret doings, etc. of the Mormons as a "wide awake woman sees them." Bright, Pure and Good, it is the best new book out, actually overflowing with good things for all. It is popular everywhere, with everybody, and outsells all other books three to one. Ministers say "God speed it." Eminent women endorse it. Everybody wants it; and agents are selling from 10 to 20 a day! 25th thousand now in press! We want 5,000 more trusty agents NOW—men or women—and we will mail outfit free to those who will canvass. Large pamphlets with full particulars, extra terms, etc. sent *gratis* to anyone. Address **A. D. WORTHINGTON & Co.,** Hartford, Conn.

GOOD NEWS for book agents, and others desiring employment. New books by popular authors, **LITTLE FOLKS IN FEATHERS AND FUR** by OLIVE THORNE, and **THE WAYS OF WOMEN**, by Dr. J. V. C. SMITH. Splendidly gotten up. Beautifully illustrated. Nothing equal to them now offered to agents. **THE LIFE AND ADVENTURES OF KIT CARSON** is still selling rapidly. Over 20,000 already sold. \$50 a week easily made. **STOWE'S SELF-INTERPRETING FAMILY BIBLE**, the finest in the world. Circulars giving full and complete information sent free. Mention the books wanted. Address, **DUSTIN, GILMAN & CO.,** Hartford, Conn.

AGENTS WANTED FOR GUIZOT'S HISTORY OF FRANCE, 400 Magnificent Illustrations.
ESTES & LAURIAT, 143 Washington St., Boston.
 WE take pleasure in announcing that we have just received news of the fact that the great Statesman, and Historian, had just completed this important work before his death. The MS. of the last vol. being now in the hands of the Paris publishers. We are now issuing the work in semi-monthly parts, at 50 cts. per part. It is one of the most superb specimens of book making ever published in America. First class canvassing agents wanted in every part of the country. It is the **GREAT BOOK** of the year. Apply at once to

HOMES AND HOW TO MAKE THEM.
 By **E. C. GARDNER,** Illustrated. \$2.00.
 "It is a treatise on house building. So much good sense and good taste on this all-important subject are not often, to our thinking, embraced within an equal compass. Whether the reader is going to build or not, he will enjoy it vastly; and if he is, he should give it his most diligent attention."—*The Congregationalist* (Boston).
 "There is hardly a matter connected with the work of building a 'home' which is not treated of wisely and well, from the choice of a site or the adaptation of a building to a site, through all the stages, from the drains and foundation walls to the modest completed building—strong but beautiful; tasteful but not merely ornamental; a little earthly paradise but yet not too grand for every-day enjoyment or use."—*Christian Intelligencer*.
 "An exceedingly sensible book, and written so entertainingly that reading it is a pleasure."—*Hartford Courant*.
 ** For sale by Booksellers. Sent, post-paid, on receipt of price, by the Publishers,
JAMES R. OSCOOD & CO., Boston.

Every **FARMER** and **STOCK RAISER**, and **EVERYBODY** that keeps a **HORSE**, a **COW**, **POULTRY**, **SHEEP** or **SWINE**—whether he lives in **CITY**, **TOWN**, or **COUNTRY**, wants the
Live Stock Journal.
 Monthly. \$1.50 per year. In its 5th Volume. Beautifully illustrated. The best instructor upon every class of Live Stock. National—giving equal attention to the Stock Interest of every State. Treats, by practical writers, upon the **Farm**, the **Dairy**, **Horses**, **Cattle**, **Sheep**, **Swine**, **Poultry**, **Bees**, **Fish** and their diseases. Specimen copy, 10 cents.
 Address **LIVE STOCK JOURNAL CO.,** Buffalo, N. Y. Good pay to agents. Agents wanted at every post-office.

CHALLENGER'S DIME ALADDIN, OR THE WONDERFUL LAMP, will delight every boy. Ask your News Dealer for it, or to Order it.

AN INTERESTING AND VALUABLE CHRISTMAS PRESENT.
WEBSTER'S POCKET DICTIONARY OF THE ENGLISH LANGUAGE.
 Abridged from Webster's Quarto, illustrated with nearly TWO HUNDRED Engravings on Wood. This volume embraces a careful selection of more than 18,000 of the most important words of the language. The introduction contains, besides the Pictorial Illustrations, **Tables of Money, Weight and Measure, Abbreviations, Words, Phrases, Proverbs, &c.**, from the Greek, the Latin, and the Modern Foreign Languages, **Rules for Spelling, &c.**; making altogether the **most complete and useful pocket companion extant.** It is beautifully printed on tinted paper, and bound in Morocco, Tucks, gilt edges, \$1. For sale everywhere. Sent by mail on receipt of the price.
IVISON, BLAKEMAN, TAYLOR & CO.,
 PUBLISHERS,
 138 & 140 Grand Street, New York.

Four New Books!
(FOR AGENTS.)
OUR FIRST HUNDRED YEARS—12 monthly parts, 50 cts. each—2 parts now published.
Life and Public Services of Charles Sumner. 5th Edition. Revised and Enlarged.
Spirit of the Holy Bible.—Illustrated by the Old Masters. 600 Illustrations. Text in English, French, and German.
Maria Monk's Daughter.—An Autobiography. Send for terms, specimen pages, and inducements.
UNITED STATES PUBLISHING COMPANY,
 13 University Place, New York.

TO BOOK AGENTS.
 We offer special and extra commissions to agents this fall. Our new books are just ready, and will stir up the reading public. We shall announce them soon. Full information sent on application, and exclusive territory given. No agent, old or new, should make arrangement for books without first negotiating with us. We can and will give agents better books, better terms, and enable them to make more money than any other house.
 Wanted—5,000 men and women as local agents, and 1 experienced men and 2 women to act as General and Traveling Agents in the North and South.
 For information of books and agencies address
AMERICAN PUBLISHING CO.,
 Hartford, Conn.

1875.—Postpaid.—\$1.60.
THE NURSERY.
 A Monthly Magazine for Youngest Readers. SUPERBLY ILLUSTRATED. Send ten cents for a Sample Number. **Subscribe NOW,** and get the last two numbers of this year **FREE!**
JOHN L. SHOREY,
 36 Bromfield Street, Boston.

Send 25 Cents for a copy of the
POULTRY WORLD.
 SPLENDIDLY Illustrated with 200 Engravings representing all the breeds of fowls. A complete repository of poultry information. Is fruitful of practical suggestions, descriptions of breeds, poultry buildings, etc.
 Address, **H. H. STODDARD, HARTFORD, CONN.**

Scribner's Lumber & Log-Book.
OVER HALF A MILLION COPIES SOLD. This is the most complete book of its kind ever published. It gives correct measurement of all kinds of lumber, logs, plank, cubical contents of square and round timber, stave and heading bolt tables, wages, rent, board, capacity of cisterns, cord-wood tables, interest, etc., and has become the Standard Book throughout the United States and Canada.
 Be sure and get the **New Edition, with Doyle's Log-Table.** Ask your bookseller for it, or I will send one for 35 cents, post-paid. **G. W. FISHER, P. O. Box 253, Rochester, N. Y.**

WANTED AGENTS—To sell the "Life and Explorations of Dr. Livingstone," complete, authentic; a fresh book; price suited to the times.
B. B. RUSSELL, Publisher, Boston, Mass.

Wm. GilloTT
STEEL PENS!
 Sold by all Dealers.
 No. 91 JOHN ST., NEW YORK.
HENRY HOE, Sole Agent. JOSEPH GILLOTT & SONS.

WRITES 10 HOURS THE HOLDER CONTAINS THE INK 3.50 & 4.00
HAWKES' PATENT HOLDER SAVES TIME, FITS ANY PEN. \$2 TO \$6 BY MAIL. SEND STAMP FOR CIRCULAR. 60 NASSAU ST. N. Y.
BUILDING PAPER!
 FOR SHEATHING, ROOFING, DEAFENING, CARPET LINING, AND PLASTERING!
 Samples from **Rock River Paper Company,** Chicago, Ill.

WANTED.—The United States Life Insurance Company is now re-organizing its Agency Department, and is prepared to negotiate with gentlemen of business ability to act as Agents. Previous connection with the business is not considered necessary.
 Apply at the Home Office, 261 Broadway, New York. **JOHN E. DEWITT, President.**

BOOKS for FARMERS and OTHERS.

[Published and for sale by the Orange Judd Company, 245 Broadway, New York. Any of these books will be forwarded by mail, post-paid, on receipt of price.]

Table listing various agricultural books with authors and prices, including titles like 'Allen's (L. F.) American Cattle', 'Bailey's Our Own Birds of the United States', and 'The Cultivation of the Willow or Osier'.

O. J. Co. keep in Stock the following Books:

Table listing books available in stock, such as 'Architecture. By Cummings & Miller', 'Bailey's Our Own Birds of the United States', and 'The Cultivation of the Willow or Osier'.

FRAMES FOR THE CHROMOS.

We have made arrangements to supply frames to our subscribers who may desire them for the Chromos which we have distributed. Many will no doubt avail themselves of this opportunity to place these beautiful pictures in handsome frames at moderate cost.

- For the Chromo, "UP FOR REPAIRS," Or for the Chromo, "LOOK OUT!" Letter A. Neat Black-Walnut Frame, Gilt Band... Letter D. Full Gilt Frame, 2 inches wide... For the Chromo, "MISCHIEF BREWING."

Address orders, specifying by its letter or number the frame desired, and inclosing price, as above, to the ORANGE JUDD COMPANY, 245 BROADWAY, NEW YORK.

The Cultivation of the Willow or Osier, By WILLIAM SCALING, Ten Years Basket Maker to Her Majesty and the Royal Family. This little pamphlet, though written by an Englishman, and of course designed especially for cultivators among his countrymen, contains just those practical instructions for the planting and culture of the willow, which many among us will be glad to receive.

Advertisement for 'AMERICAN AGRICULTURIST' featuring a decorative border, the text 'SUBSCRIBE NOW FOR THE AMERICAN AGRICULTURIST', and details about subscription prices and the 'Chromo' feature.

CHEAP FARMS AND FREE HOMES

IN THE
GREAT PLATTE VALLEY,
THE GARDEN OF THE WEST.

A LAND GRANT OF
12,000,000 ACRES
OF THE
Best Farming, Grazing, and Mineral
Lands in America.

THE
Union Pacific Railroad Co.

OFFER FOR SALE
3,000,000 ACRES
OF CHOICE

FARMING and GRAZING LANDS
ON THE LINE OF THE ROAD IN THE
STATE OF NEBRASKA.

ON TEN YEARS CREDIT, INTEREST
ONLY 6 PER CENT.

Cheaper in Price, More favorable Terms
given, than can be found Elsewhere.

Convenient to Markets East and West.

Now is the Time to Secure a Home!!

JUST OUT:

The Second Number of

THE PIONEER,

A handsome ILLUSTRATED PAPER, with Maps, etc., and
containing the Homestead Law, also the new TIMBER
LAW. Mailed free to all applicants, by addressing

O. F. DAVIS,

Land Commissioner, U. P. R. Co.,
OMAHA, NEB.

CHICAGO & NORTH-WESTERN RY. THE TRANS-CONTINENTAL ROUTE.

This is the Pioneer line between Chicago and the Pacific
Coast, and was the first to connect with the great Pacific
roads, and form the OVERLAND ROUTE. This line is
the shortest rail line between Chicago and Omaha; the track
is of the best steel rail, and is well ballasted, and as free
from dust as a road can be made; the bridges are strong
and durable; and all the appointments are first-class in
every respect. The trains that run over this line are made
up of elegant new Pullman Palace Drawing Room and
Sleeping Coaches built expressly for this line, luxurious,
well lighted and well ventilated Day Coaches, and pleasant
lounging and smoking cars; all built by this Company in
their own shops. The cars are all equipped with the cele-
brated Miller Safety Platform, and patent Buffers and Coup-
plings, Westinghouse Safety Air Brakes, and every other ap-
pliance that has been devised for the safety of passenger
trains. All trains are run by telegraph. In a word, this
GREAT CALIFORNIA LINE has the best and smoothest
track, and the most elegant and comfortable equipment of
any road in the West; and has no superior in the country.
It is eminently the favorite route with Chicagoans traveling
west, and is acknowledged by the traveling public to be the
popular line for all points in Western Iowa, Nebraska, Wy-
oming, Colorado, Utah, Montana, Idaho, Nevada, Califor-
nia, and the Pacific Slope.

All Coupon Ticket Agents sell tickets by this route. If
you are going West, you should try this route.

NEW YORK OFFICE: No. 229 Broadway.
BOSTON OFFICE: No. 5 State Street.

CHICAGO TICKET OFFICES:

62 Clark Street, under Sherman House.
Corner Canal and Madison Streets.
Kinzie Street Depot, corner West Kinzie and Canal Streets.
Wells Street Depot, corner Wells and Kinzie Streets.

MARVIN HUGHITT, W. H. STENNETT,
General Superintendent. General Passenger Agent.



Do Your Own Printing
Excelsior Portable Presses
\$9 Press for cards, labels, envelopes
etc. Larger sizes for large work.
Business Men do their printing and
advertising, save money and increase
trade. Amateur Printing, delight-
ful pastime for spare hours. BOYS
have great fun and make money fast
at printing. Send two stamps for full
catalogue presses type etc, to the Mfrs
KELSEY & CO. Meriden, Conn.

FIRE PROTECTION For Cities & Towns.

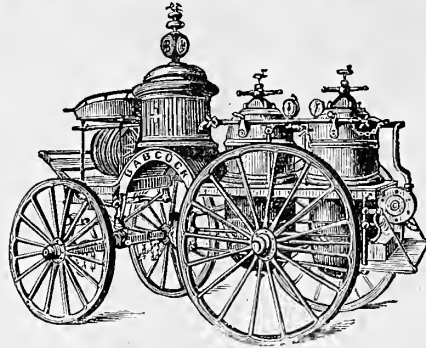

BABCOCK

SELF-ACTING FIRE ENGINE.

Adopted by New York, Boston, Chicago, Cincinnati,
and One Hundred other Cities.

THE BABCOCK MANUFACTURING COMPANY,
407 Broadway, New York.
317 to 331 South Desplains St., Chicago.

Gardening for Profit.

A Guide to the Successful Cultivation of
the Market and Family Garden.

By PETER HENDERSON.

Finely Illustrated. Price, Post-paid, \$1.50.

The following voluntary notice of this book comes from
a Western market gardener and shipper of vegetables, and
is a specimen of similar testimony from very many quarters.

March 23d, 1874.

"If this should go to Mr. Henderson, I would say that I
believe the gardeners of this country would gladly hail an-
other edition of 'Gardening for Profit.' at least, I thank
him for that little work. Through its influence I left a pay-
ing manufacturing business and began to follow its teach-
ings. This was three years ago. Now I have a market
garden of thirty acres and 400 four-foot sash, and enjoy my-
self as I never did before. Again I thank him."

ORANGE JUDD COMPANY,
245 BROADWAY, NEW YORK.

READ A STORY

ABOUT

CRANDALL'S ACROBATS.

We lately carried home a box of these amusing toys. A
deeply interested audience awaited the opening of the ex-
hibition. There were three little children, aged seven, five,
and two, respectively, and four big children, ranging from
twenty-nine to forty years of age. Little seven-year-old put
the acrobats together, aided by little five-year-old, while
little two-years gazed in wrapt admiration and enjoyment.
The excitement grew as the queer figures took shape and
assumed fantastic postures. Then big thirty-seven-year-old
tried his hand at the amusement, and very soon the merry
voices of old and young joined in a hearty laughing chorus
over the oddities of one of the most laughable and enter-
taining toys that we have seen for many years. It is a hap-
py hit, which will make the inventor's fortune, and is
nothing more nor less than wooden men in detail, the
bodies, heads, legs, and arms, separate, and so grooved that
they can be readily put together in an almost endless var-
iety of fantastic shapes and figures. They are colored as
acrobats, and as they perform feats never even attempted
at BARNUM'S, are fully entitled to their name. A pleasant
feature is their cheapness. The Orange Judd Publishing
Company, No. 245 Broadway, in this city, are the proprietors
of this "Great Show," which may be exhibited in every
home, and "no postponement on account of the weather."
From "The Christian at Work."

Price of "Crandall's Acrobats"—\$1 per box at 245 Broad-
way, or \$1.15 if sent post-paid.

ORANGE JUDD COMPANY,
245 BROADWAY, NEW YORK.

CRANDALL'S IMPROVED BUILDING-BLOCKS FOR CHILDREN.

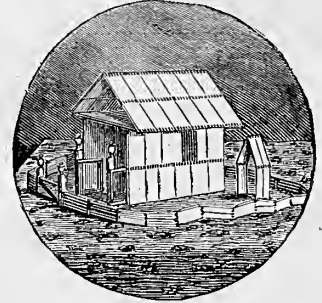

BEAUTIFUL, AMUSING, INSTRUCTIVE.

CRANDALL'S Building-Blocks

Can be made into forms of almost endless variety.

The blocks are put up in neat, strong boxes, and
a large sheet giving various designs of buildings,
etc., accompanies each box.

Price—No. 1, \$2.00; by mail, prepaid, \$2.25.
No. 3, \$1.00; by mail, prepaid, \$1.10.
No. 4, \$1.00; by mail, prepaid, \$1.10.

CRANDALL'S Masquerade-Blocks,

Making 300 different and beautiful Combinations
of Pictures, which are in very brilliant colors.
They are not injured by washing, do not wear out,
and afford endless amusement.

Price \$1.00; by mail, prepaid, \$1.10.

CRANDALL'S Expression-Blocks,

With Letters on one side, Picture on the other.
The Alphabet is the key to the picture which, when
complete, represents the inventor in Dream Land.
These Blocks are water-proof, and can be washed
if soiled.

Price 50 Cts.; by mail, prepaid, 60 Cts.

CRANDALL'S Alphabet-Blocks.

Red, White, and Blue.

Tasteless, odorless, and water-proof. The letters
are on red, white, and blue ground. All children
are pleased with them.

Price 75 Cts.; by mail, prepaid, 85 Cts.

Crandall's Acrobats.

Full of fun and frolic, and most brilliant in costume.
These are among the most fascinating and ingeni-
ous toys ever invented. The number of figures
which can be made with the pieces in a single box
is limited only by the ingenuity of the operator.

Price \$1.00; by mail, prepaid, \$1.15.

N.B.—If postage is not remitted with the prices, as above,
the blocks will be sent by express at purchaser's expense.

Orders from the trade will be supplied on liberal terms.

ORANGE JUDD COMPANY,
245 BROADWAY, NEW YORK.



SMITHSONIAN INSTITUTION LIBRARIES



3 9088 90032 9384