





7

H

THE AMERICAN JOURNAL
OF
PHYSIOLOGY.

EDITED FOR

The American Physiological Society

BY

H. P. BOWDITCH, M.D., BOSTON

R. H. CHITTENDEN, Ph.D., NEW HAVEN

W. H. HOWELL, M.D., BALTIMORE

FREDERIC S. LEE, Ph.D., NEW YORK

JACQUES LOEB, M.D., CHICAGO

W. P. LOMBARD, M.D., ANN ARBOR

W. T. PORTER, M.D., BOSTON

THE
AMERICAN JOURNAL
OF
PHYSIOLOGY

VOLUME VIII.

BOSTON, U.S.A.
GINN AND COMPANY

1903

87437
5.16/08

QP
I
A5
v.8
cop.2

Copyright, 1903
BY GINN AND COMPANY

University Press
JOHN WILSON AND SON, CAMBRIDGE, U.S.A.

CONTENTS.

No. I, OCTOBER 1, 1902.

	PAGE
ON THE FUNCTIONS OF THE CEREBRUM: I.—THE FRONTAL LOBES IN RELATION TO THE PRODUCTION AND RETENTION OF SIMPLE SENSORY-MOTOR HABITS. <i>By Shepherd Ivory Franz</i>	1
STUDIES ON REACTIONS TO STIMULI IN UNICELLULAR ORGANISMS. IX.—ON THE BEHAVIOR OF FIXED INFUSORIA (STENTOR AND VORTICELLA), WITH SPECIAL REFERENCE TO THE MODIFIABILITY OF PROTOZOAN REACTIONS. <i>By H. S. Jennings</i>	23
THE ACTION OF ALCOHOL ON MUSCLE. <i>By Frederic S. Lee and William Salant</i>	61

No. II, NOVEMBER 1, 1902.

THE IMPORTANCE OF SODIUM CHLORIDE IN HEART ACTIVITY. <i>By David J. Lingle</i>	75
NOTES ON THE ACTION OF ACIDS AND ACID SALTS ON BLOOD-CORPUSCLES AND SOME OTHER CELLS. <i>By S. Peskind</i>	99
THE BEHAVIOR OF NUCLEATED COLORED BLOOD-CORPUSCLES TO CERTAIN HEMOLYTIC AGENTS. <i>By G. N. Stewart</i>	103

No. III, DECEMBER 1, 1902.

THE EFFECT OF DIMINISHED EXCRETION OF SODIUM CHLORIDE ON THE CONSTITUENTS OF THE URINE. <i>By R. A. Hatcher and Torald Sollmann</i>	139
THE MECHANISM OF THE RETENTION OF CHLORIDES: A CONTRIBUTION TO THE THEORY OF URINE SECRETION. <i>By Torald Sollmann</i>	155

	PAGE
DOES POTASSIUM CYANIDE PROLONG THE LIFE OF THE UNFERTILIZED EGG OF THE SEA-URCHIN? <i>By F. P. Gorham and R. W. Tower . . .</i>	175
NOTES ON THE "PROTAGON" OF THE BRAIN. <i>By W. W. Lesem and William J. Gies</i>	183
ON THE GROWTH OF SUCKLING PIGS FED ON A DIET OF SKIMMED COW'S MILK. <i>By Margaret B. Wilson</i>	197
MAXIMAL CONTRACTION, "STAIRCASE" CONTRACTION, REFRACTORY PERIOD, AND COMPENSATORY PAUSE, OF THE HEART. <i>By R. S. Woodworth</i>	213

NO. IV, JANUARY 1, 1903.

THE RATE OF NERVOUS IMPULSE IN CERTAIN MOLLUSCS. <i>By O. P. Jenkins and A. J. Carlson</i>	251
ON THE INFLUENCE OF CALCIUM AND POTASSIUM SALTS UPON THE TONE OF PLAIN MUSCLE. <i>By Percy G. Stiles</i>	269
ON DIFFERENCES IN THE DIRECTION OF THE ELECTRICAL CONVECTION OF CERTAIN FREE CELLS AND NUCLEI. <i>By Ralph S. Lillie</i>	273
AN EXPERIMENTAL STUDY OF THE CHEMICAL PRODUCTS OF BACILLUS COLI COMMUNIS AND BACILLUS LACTIS AEROGENES. <i>By Leo F. Rettger</i>	284
ELECTRICAL POLARITY IN THE HYDROIDS. <i>By Albert P. Mathews</i>	294
THE IMPORTANCE OF MECHANICAL SHOCK IN PROTOPLASMIC ACTIVITY. <i>By A. P. Mathews and B. R. Whitcher</i>	300
FIVE TYPES OF EYE MOVEMENT IN THE HORIZONTAL MERIDIAN PLANE OF THE FIELD OF REGARD. <i>By Raymond Dodge</i>	307
ON THE QUANTITATIVE DETERMINATION OF AMMONIA IN URINE. <i>By Philip Shaffer</i>	330
THE INFLUENCE OF FATIGUE UPON THE SPEED OF VOLUNTARY CONTRACTION OF HUMAN MUSCLE. <i>By Thomas Andrew Storey</i>	355

NO. V, FEBRUARY 2, 1903.

A PHYSIOLOGICAL STUDY OF NUCLEIC ACID. <i>By Lafayette B. Mendel, Frank P. Underhill, and Benjamin White</i>	377
THE ACTION OF ACIDS AND ACID SALTS ON BLOOD-CORPUSCLES AND OTHER CELLS. <i>By S. Peskind</i>	404
HOW LONG DOES (ARBACIA) SPERM LIVE IN SEA-WATER? <i>By Martin H. Fischer</i>	430
VARIATIONS IN THE AMPLITUDE OF THE CONTRACTIONS OF HUMAN VOLUNTARY MUSCLE IN RESPONSE TO GRADED VARIATIONS IN THE STRENGTH OF THE INDUCED SHOCK. <i>By Thomas Andrew Storey</i>	435

Contents.

vii

PAGE

THE LAKING OF DRIED RED BLOOD-CORPUSCLES. <i>By Charles Claude Guthrie</i>	441
ON THE NUCLEOPROTEIDS OF THE PANCREAS, THYMUS, AND SUPRARENAL GLAND, WITH ESPECIAL REFERENCE TO THEIR OPTICAL ACTIVITY. <i>By Arthur Gamgee and Walter Jones</i>	447
PROCEEDINGS OF THE AMERICAN PHYSIOLOGICAL SOCIETY	ix-xliii
<hr/>	
INDEX	457

PROCEEDINGS OF THE AMERICAN PHYSIO-
LOGICAL SOCIETY.

FIFTEENTH ANNUAL MEETING.

WASHINGTON, D. C., DECEMBER 30 and 31, 1902.

PROCEEDINGS OF THE AMERICAN PHYSIOLOGICAL SOCIETY.

ON GLUCOTHIONIC ACID.

By P. A. LEVENE.

IN the preparation of nucleic acid by the picric acid-alcohol method, a carbohydrate is precipitated with the acid. The carbohydrate can be removed by copper chloride. In the yeast, in bacteria, pancreas, and liver the carbohydrate resembled glycogen. In the spleen, it had properties similar to those of chondroitin sulphuric acid. It contained sulphuric acid in organic combination, and it gave the barium test for glycuronic acid. Unlike the chondroitin sulphuric acid, its sulphur was equal to 3 per cent and its nitrogen to 5.41 per cent. Very characteristic of the substance is its behavior toward orcin-hydrochloric acid. Chondroitin sulphuric acid, as well as pentose, on heating with orcin-hydrochloric acid gave a purple color, soon turning into green on the separation of dark green floccules. The substance of the spleen forms with the same reagents a bright purple color which remains unchanged for days; the floccules have the same bright purple color. It is possible that the substance is not unlike the glucosaminic acid described by Fischer, combined with sulphuric acid.

ON GLUCOPHOSPHORIC ACID.

By P. A. LEVENE.

THE author analyzed in various seeds the phosphorus-containing substance first obtained by Paladin and analyzed by Schulze and Winterstein. These authors failed to establish the nature of the organic radical of the substance. The author found that about 30 per cent of the organic part could be split off in form of a carbohy-

drate. The carbohydrate gave all the qualitative tests for a pentose. The phenylhydrazin compound and the bromphenylhydrazin compound possessed all the properties of the pentose derivatives, yet they were not pure enough to establish their identity. The substance contained about 15 per cent of organic phosphorus, 1.8 per cent of nitrogen, and 50 per cent of ash, which consisted chiefly of calcium-magnesium-phosphate. The substance contained no glycerine or purin bases.

ON NUCLEIC ACID.

By P. A. LEVENE.

THE author continued his analysis of some nucleic acids. Attention was directed toward the presence or absence in the spleen and pancreas of the following substances: glycerine, a carbohydrate, pyrimidin derivatives. Glycerine could not be found in any perceptible quantity. A carbohydrate could not be isolated, but five different nucleic acids, namely, those of the pancreas, spleen, liver, yeast, and tubercle bacilli gave all the furfural tests on distillation with mineral acids. Thymin could be isolated from the nucleic acids of both pancreas and spleen. From the same two acids there was obtained, in the form of a picrate, a substance which could be transformed into a disulphate. The composition of the two salts was as follows:

For the picrate, calculated as: $(C_4H_6N_3O)C_6H_2(NO_2)_3OH$,

	Calculated.	Found.
C	35.07%	35.56%
H	2.64%	2.91%
N	24.65%	25.11%

For the sulphate, calculated:

	Calculated.	Found.
C	29.90%	29.44%
H	4.34%	4.01%
N	26.16%	26.25%
S	9.62%	9.84%

In its elementary composition the substance is not unlike crytosin, as described by Kossel. The formula for episarkin, however seems to correspond better with the analytical data. It is, perhaps, an amino-oxy-pyrimidin.

FURTHER MUCOID STUDIES.

BY WILLIAM J. GIES.

I. INVESTIGATIONS into the distribution of osseomucoid indicate that glucoproteid is a normal constituent of all bones. It has thus far been found in the large bones of wild and domestic mammals and birds, and of reptiles.

II. Connective tissue mucoid shows a tendency to combine with other proteids. Thus, for example, an alkaline solution of potassio-mucoid and gelatine yields a precipitate with acid more promptly than a solution of the equivalent amount of the mucoid salt alone. Furthermore, the compound precipitate is different physically. In the case of the gelatine product the precipitate possesses semi-gelatinous qualities. The compound precipitates of mucoid obtained from proteid solutions weigh more than the control mucoid precipitates. This added weight rises, within certain limits, as the proportion of associated proteid in the solution increases.

III. Acidification of tissue extracts is not sufficient for complete precipitation of the mucoid. Even with a fifth alkaline extract of the same tendon pieces, the water-clear acid filtrate from the precipitated mucoid contains additional glucoproteid.

IV. Precipitated mucoid shows practically no combining power with acids. In the hydration of mucoid by pepsin-acid, however, acid combines with the dissolved proteid products formed in the process.

V. The blood serum of a rabbit, which had been treated with several subcutaneous and intraperitoneal injections of neutral solution of potassio-mucoid, produced precipitates in neutral and slightly acid solutions of the latter proteid substance.

These researches are still in progress with the co-operation of Messrs. E. R. Posner, C. Seifert, and H. G. Baumgard.

ON THE ORIGIN OF GLYCURONIC ACID.

BY J. A. MANDEL AND H. C. JACKSON.

MAYER (*Verhandlungen des Congresses für innere Medicin*, 1901, p. 393), in a series of inadequate experiments on rabbits, which were fed camphor before and after fasting, claims a direct formation of glycuronic acid from the dextrose of the body. He also considers that

glycuronic acid is a normal constituent of the blood. Other investigators also give this origin for the glycuronic acid which combines with foreign substances when introduced into the organism, and nearly all have ignored the possibility of its origin from the proteids.

We fed camphor to fasting dogs for several days, and estimated the campho-glycuronic acid and nitrogen excreted, and then fed large quantities of dextrose (80 grams) for several days, and observed a marked diminution in the elimination of both campho-glycuronic acid and nitrogen. On giving the animal chopped meat, the quantities of campho-glycuronic acid and nitrogen were correspondingly increased, and a constant elimination was obtained as long as the meat and camphor were fed, showing a positive proteid origin for the glycuronic acid.

In a series of experiments, making use of two different methods for removing proteids, we have failed to detect glycuronic acid in the blood. In order to ascertain the seat of formation of the conjugated glycuronates, we made several transfusion experiments by passing the blood of one dog, which had been previously fed with large doses of camphor, through the kidneys of a second dog and found that the urine collected during transfusion was lævo-rotatory and contained campho-glycuronic acid. Incidentally we found that the kidneys of all our camphor-fed dogs showed, on microscopical examination, a pronounced fatty degeneration in the ascending loops of Henle and not in the convoluted tubules. It is not improbable that these cells are concerned in the synthesis of the glycuronates.

FURTHER STUDIES OF THE TOXIC AND ANTITOXIC EFFECTS OF IONS.

BY JACQUES LOEB AND WILLIAM J. GIES.

THIS research was conducted at Wood's Holl during the past summer. It confirmed Loeb's original observation that each electrolyte in solution at a certain concentration is able to prevent the development of the *Fundulus* egg after fertilization, and also to destroy the egg. Our experiments further confirmed the fact that this poisonous action can, in general, be wholly or partly inhibited by the addition of a proper amount of another electrolyte.

We also obtained results emphasizing the fact first observed by

Loeb, and furnishing new evidence to show, that the degree of antitoxic influence exerted by the second electrolyte increases with the valency of the cation. The antitoxic action of bivalent cations was found to be very much greater than that of univalent cations, the antagonistic power of trivalent cations is considerably greater than that of the bivalent. This rule does not hold with all cations, however; such cations as Cu, Hg, and Cd are exceptions.

Our experiments made it very apparent that the antitoxic action of the salts employed was not due to slight amounts of H or OH ions in their dissociated solutions, since neither solutions of pure acids nor of pure alkalies were able to exert such antagonism.

It was found, finally, that solutions of non-electrolytes, *e. g.*, urea, cane-sugar, glycerine, alcohol, have no antitoxic influence except under conditions which favor the formation of not easily soluble dissociable compounds with the electrolyte (such as saccharate), whereby the concentration of the toxic ion is considerably reduced.

Koch's recent investigations on the influence of ions on lecithin solutions emphasize the possibility previously suggested by Loeb, that the observed antagonistic effects of ions may be referred, in part at least, to changes induced in the physical and perhaps chemical conditions of substances such as lecithin in the cell.

A PROTEID REACTION INVOLVING THE USE OF CHROMATE.

BY WILLIAM J. GIES.

SEVERAL years ago, during a comparative study of the reactions of various gelatines, the results of which have not yet been published, it was observed by Dr. D. H. M. Gillespie and myself that dilute solutions of potassium chromate did not precipitate gelatine solutions, but that when such proteid-chromate mixtures were further treated with acid, a fine yellow flocculent precipitate formed at once. Acids as "weak" as acetic, and also the common mineral acids, effected the result, the latter acids more promptly, however, even in smaller amount.

At intervals I have returned to this reaction, and lately have made a more careful study of it. Solutions of chromates of mono- and divalent cations (the only ones thus far employed) cause no precipi-

tates in neutral or alkaline proteid fluids, but on further treatment with small amounts of dilute acids, — strongly dissociable ones particularly, — flocculent precipitation of a proteid-chromate compound occurs in every case. The reaction is especially striking with such bodies as gelatine and proteose (the precipitates with these disappearing on warming and reappearing on cooling), and it seems to be more delicate than the acetic acid and potassium ferrocyanide test. Salts containing dichromion or trichromion behave differently.

Since bichromate is formed from chromate on the addition of acid, it might be supposed that such production is responsible for the precipitation observed. But bichromate solutions are as inert as the chromate. When, however, acid is added to a mixture of proteid and bichromate, precipitation occurs, as in the case with chromate. Hydroxidion prevents the reaction in all cases. Possibly the precipitation is due to the formation of dichromic acid, just as in the acetic acid and potassium ferrocyanide test it is dependent on the formation of hydroferrocyanic acid.

Further study is expected to determine exactly the character of the ions responsible for the reaction. The results thus far point to dichromanion in the presence of hydrion.

NEW EXPERIMENTS ON THE PHYSIOLOGICAL ACTION OF THE PROTEOSES.

BY LAFAYETTE B. MENDEL AND FRANK P. UNDERHILL.

In a recent study of the physiological action of the proteoses, after direct introduction into the circulation of higher animals, Pick and Spiro (*Zeitschrift für physiologische Chemie*, 1900, xxxi, p. 235) conclude: "Es gibt 'Peptone' ohne 'Peptonwirkung' und 'Peptonwirkung' ohne 'Peptone.'" Their experiments gave the following indications: (1) It is possible to obtain typical albumoses and peptones after cleavage of proteids (fibrin) by trypsin, autolysis, and alkalies, and by the action of acid on casein and edestin. These products, when introduced into the blood, fail to show any effect on blood-pressure. Furthermore, active products prepared by acid or pepsin-acid lose their typical action after purification by a method which apparently does not alter their chemical character. (2) It is possible to obtain preparations which develop the anti-clotting action in marked degree,

although they may contain only traces of albumoses and peptones, or even none at all. From this the authors conclude that the property of retarding blood-clotting is attributable not, to the albumoses as such, but to an adherent and extremely active substance which is present, perhaps, in very small quantity.

Earlier experiments in our laboratory (This journal, 1899, ii, p. 142) have led us to question the general application of these conclusions in the case of proteoses purified according to the standards current for these substances. Since then a considerable number of typical products have been prepared under conditions which would exclude as far as possible the presence of the specific contaminating tissue substance (peptozyme) assumed by Pick and Spiro to be the active agent. The number includes native proteoses separated directly from the wheat embryo, hemp seed, and brazil nut without the use of foreign enzymes or acids; proteoses prepared by the action of superheated water or of dilute acids on crystallized proteids; proteoses prepared by the digestion of edestin and casein with the vegetable enzymes papain and bromelin: products purified by the methods of Pick and Spiro. All of these proteose preparations, introduced in doses of 0.3 to 0.5 gm. per kilo of body weight into the circulation of dogs, have provoked the characteristic symptoms noted in our earlier work, namely: a fall in arterial pressure, diminished coagulability of the blood, a transitory stage of excitation followed by narcosis, a degree of "immunity," and (in the single experiment thus far tried) lymphagoc effects. The investigation is being continued.

IS THE ACTION OF ALCOHOL ON GASTRIC SECRETION SPECIFIC?

BY GEORGE B. WALLACE AND H. C. JACKSON.

EXPERIMENTS were performed with the object of determining whether the flow of gastric juice caused by the introduction of alcohol into the intestine is due to a purely reflex action, and further whether it is an effect produced by irritant substances other than alcohol.

Dogs were used in the experiments. The stomach was washed till free of acid, the pylorus then ligated, and the substance to be studied injected directly into the intestine. Three hours after the

injection the dog was killed, the stomach removed and its contents collected and analyzed. The total amounts as well as the percentage of the various acidities were estimated. In some of the experiments the nerve supply to the stomach was cut off, by extirpating the cardiac ganglion of the sympathetic system and cutting the vagus fibres passing down the walls of the stomach. Oil of peppermint was taken for comparison with alcohol as an irritant.

40 c.c. of 25 per cent alcohol, injected into the intestine, produced a gastric flow five times as great in amount as when water alone was injected. The total and free acid was increased in the same proportion. 0.3 c.c. of oil of peppermint, in acacia emulsion, produced an effect practically identical with that of alcohol.

With the gastric nerve supply cut off, the alcohol and oil of peppermint injected into the intestine produced no greater effect than when water alone was injected.

Even when alcohol was injected directly into the stomach, the gastric nerve supply being cut off, it induced a gastric secretion but little greater than when water was injected.

The conclusions are (1) that alcohol introduced into the intestine stimulates the gastric secretions not through its absorption and subsequent action on the gastric mucosa, but by a purely reflex action; (2) that this action is not limited to alcohol, but is possessed by other irritant substances, such as oil of peppermint.

A PRELIMINARY REPORT ON THE PHARMACOLOGICAL AND CHEMICAL PROPERTIES OF TRI-BROM-TERTIARY BUTYL-ALCOHOL.

BY E. M. HOUGHTON AND T. B. ALDRICH.

WILLGERODT, in a paper dealing with tri-chlorotertiary butyl-alcohol or acetone chloroform, mentioned having obtained a similar product containing bromine in place of the chlorine, which he called tri-brom-tertiary butyl-alcohol, but he did not make a careful examination of its chemical and physical properties, and seems not to have considered at all its pharmacological properties. This bromine compound is produced by the action of caustic alkalis upon mixtures of bromoform and acetone. The excess of acetone and bromoform having been distilled off, the new bromine compound is removed from the residue

by distillation with steam, the product being finally purified by re-crystallization from alcohol or other suitable solvent. The purified substance is a white crystalline body having a camphoraceous odor and taste. The melting point is about 167° C. It is soluble in most of the organic solvents, as alcohol, ether, benzoine, etc., slightly soluble in cold and more soluble in hot water.

This compound, since it is a derivative of the fatty acid series, when administered in various ways to animals possesses decided anæsthetic properties; recovery from small quantities takes place without any apparent untoward results. The drug appears to have very little influence upon the heart or circulation, as shown by myocardiographic and blood-pressure tracings taken from curarized animals.

It is suggested that the name brometome be given to the compound.

THE ACTION OF ETHYL-ALCOHOL ON CONTRACTILE PROTOPLASM.

BY FREDERIC S. LEE.

THE spontaneous contractions of the bell of the medusa, *Gonionema*, are markedly increased in number by small quantities of ethyl-alcohol in sea-water. This increase becomes progressively greater with solutions ranging from $\frac{1}{16}$ per cent to $\frac{1}{4}$ per cent; then progressively less, until with about 2 per cent the contractions are nearly normal in number; with stronger alcohol they are irregular, feeble, and partial. These results agree with those obtained by the author and Salant on frog's striated muscle, and strengthen the proof that ethyl-alcohol in small quantity is favorable, in larger quantity unfavorable, to the activity of contractile protoplasm. The behavior of the bell of *Gonionema*, with the nerve-ring removed, supports this conclusion.

Concentrated sea-water acts like weak alcohol, but the amount of concentration that is required in order to produce a given increase in the rate of contraction is so great as to preclude the idea that abstraction of water from protoplasm is the important causative factor in the favorable action of alcohol.

EXHIBITION OF NEW FORM OF PLATINUM-MERCURY
STIMULATOR.

BY W. P. LOMBARD (FOR W. P. BOWEN).

FOUR wooden disks two inches in diameter are mounted on a light shaft so as to rotate in separate mercury troughs in the wooden base. A platinum wire is placed radially in each disk, and brought even with the surface of the edge; the disks are adjusted on the shaft so that in each of the two pairs the wires are opposite; then the central ends of the wires of each pair are connected, thus forming two metallic staples whose ends dip in the mercury and connect the troughs in pairs. One pair of disks is now set so as to make and break contact slightly before the other pair. The binding posts of one pair of troughs are now connected with the primary, and those of the other with the secondary circuits of an induction coil.

Practice in the laboratory has shown this to be a very efficient stimulator for rates up to 3 or 4 per second. At higher rates, the mercury is thrown, but the use of a cover will permit rates somewhat higher. The staple of platinum being imbedded in the smooth wooden disk prevents waves of mercury being formed as the staple passes through, — a fault of many otherwise excellent stimulators in common use.

EXHIBITION OF MERCURY-MERCURY STIMULATOR.

BY W. P. LOMBARD (FOR W. P. BOWEN).

PROFESSOR WARREN of Bryn Mawr once said that "Eternal brightness is the price of electricity." Constant brightness at the point of contact is one absolute essential of the ideal stimulator. It is secured in this instrument by making and breaking a column of mercury by means of a celluloid disk perforated with holes of uniform size and rotated at a uniform rate.

The mercury is held in wooden reservoirs; from the base of each a glass tube projects horizontally; two of these are placed on opposite sides of the disk with the axes of the tubes forming one line and the ends of the tubes just far enough apart for the disk to rotate between. The disk interrupts the circuit except while a hole is

passing between the ends of the tubes. At such a time there is a momentary contact of mercury from the two tubes; then the hole moves on, carrying with it the mercury which fills it, including most of the oxide produced by the spark, and this waste mercury drops into a beaker beneath the instrument.

The frequency of stimulation can be varied either by changing the rate of rotation of the disk or the number of holes contained in it. This instrument has given good curves with a 2-hole disk at $7\frac{1}{2}$ revolutions per second, which is the fastest rate tried. With a 6-hole disk this gave 45 stimuli per second, and the rate can be increased to 270 per second by making more holes in the disk. The ease with which the disks can be made also makes it possible to vary the manner of stimulation widely, if desired.

A second pair of reservoirs, placed on the opposite side of the shaft turning the disk and properly adjusted, provides a short circuit for cutting out the making shocks.

Most stimulators, as a result of corrosion due to sparking, fail to give regular results with less than a maximal stimulus; but this instrument gives fine curves with almost any strength of current.

FURTHER OBSERVATIONS ON THE MOVEMENTS OF THE STOMACH AND INTESTINES.

By W. B. CANNON.

THE cat has been used in the researches I have hitherto reported; it is important to know if the observations made on the cat are true also for other animals.

Rhythmic segmentation of the food has been repeatedly observed in the small intestine of the dog, at the rate of from 18 to 22 operations per minute; and in the white rat, 44 to 48 operations per minute. The guinea pig and rabbit have shown no typical segmenting movements. A to-and-fro swinging of the food in one place has been seen in the rabbit; and also segmentation combined with peristalsis, as described for the cat.¹

Antiperistalsis at the beginning of the large intestine has been observed in the dog, at the rate of four waves per minute. These

¹ CANNON: This journal, 1902, vi, p. 260.

antiperistaltic waves in the dog and cat are possibly to be correlated with antiperistalsis in the cæcum of the rabbit. The appearance of fresh food in the cæcum of the rabbit is followed by a deep constriction which sweeps the food swiftly toward the blind end.

The stomach movements were similar in all animals observed. In the dog, rabbit, guinea pig, cat, and rat peristalsis is seen only over the pyloric end.

The gastric peristalsis can be inhibited in the rabbit, the dog, and the guinea pig, just as in the cat, by causing respiratory distress.

Feeding a cat a fluid food makes it possible to demonstrate a fairly rhythmic relaxation of the cardia. At every relaxation the food pours through the cardia and passes up the œsophagus to the level of the heart or the base of the neck; and it is immediately swept thence into the stomach again by a peristaltic wave. This activity may recur about every half minute for a half hour or more.

Observations have also been made on the treatment of different foodstuffs in different parts of the alimentary canal. Cats were given equal amounts of carbohydrate or proteid foods, having as near as possible the same consistency. The carbohydrate food appeared in the intestine usually within ten minutes; the proteid food usually did not begin to leave the stomach for an hour or an hour and a half after it was eaten. Similar observations were made in comparing fats and proteids; the proteids were retained in the stomach nearly twice as long as fats of the same amount and consistency. In the small intestine the proteids may be seen undergoing segmentation at almost any time; the carbohydrates and fats undergo this process comparatively rarely.

SOME MINOR IMPROVEMENTS IN LABORATORY APPARATUS.

By COLIN C. STEWART.

1. A moist chamber; 2. An electro-magnetic signal; 3. A frog-table; 4. A mercury key in which the movable part of the key is hinged in the bottom of one mercury cup to dip into a second, with fixed binding posts running to each cup; 5. A contact end for a flexible wire cable; 6. A cardiopneumatiscope, consisting of a curved glass tube sealed to a pin-hole opening at the distal to prevent the too rapid escape of the cigarette smoke with which the tube is

filled ; 7. A tracheal cannula, for artificial respiration, in which the troublesome metal collar which regulates the size of the opening through which the expiratory blast escapes, is replaced by a short piece of rubber tubing.

ON THE BIOLOGICAL RELATION OF PROTEIDS AND
PROTEID ASSIMILATION.

BY P. A. LEVENE AND L. B. STOOKEY.

IN applying the precipitin test, the authors observed that different proteids of a given animal, and perhaps of a given species, possess a certain similarity which distinguishes them from all the proteids of any other origin. This biological individuality of proteids could serve to explain the cause of the fact that proteid material ingested has to be broken up by the organism before it is utilized. The molecule of foreign proteid material has to be reconstructed into the molecule characteristic of the given animal.

The second aim of the authors was to establish the place of the breaking down of ingested proteid. Attempts were made to solve also this problem by the application of the precipitin test. This part of the work is not yet complete. The authors, however, think that foreign proteids normally do not pass the digestive system (liver included) unchanged.

ON THE DIGESTION OF GELATINE.

BY P. A. LEVENE AND L. B. STOOKEY.

It is known that gelatine does not yield on digestion with proteolytic enzymes any perceptible quantity of the usual crystalline digestive products. It was, however, established by Chittenden and Solley that it undergoes transformation into proteoses and peptone like any other proteid. One of the authors, Levene, found that these digestive products differ in their content of glycocoll. He also observed that gelatine subjected to prolonged digestion yields comparatively little of the usual crystalline digestive products. In order to gain some light upon the process of transformation of gelatine into gelatoses, the authors investigated the formation of free ammonia in the course of tryptic digestion of gelatine, and observed that the free ammonia increases as the gelatine is transformed into the primary and the primary into the secondary albumoses.

THE SECOND MAXIMUM IN THE RESPONSE OF MUSCLE
TO STIMULATION.

BY COLIN C. STEWART.

WITH single break induction currents of gradually increasing strength the contraction of the frog's gastrocnemius (and other muscles) increases from a minimum to a maximum. Further increase in the strength of the current elicits no greater response for a time, but finally results in a second increase in the height of the contraction and a second and final maximum.

This second maximum is not due to any peculiarity of the induction apparatus, nor to the presence in the gastrocnemius of muscle fibres of two different lengths. It is obtained with curarized muscle stimulated directly, as well as with uncurarized muscle stimulated indirectly. The maxima for muscle stimulated indirectly occur earlier, that is, with weaker currents, than the maxima which are to be obtained with direct stimulation. It follows, therefore, that with fresh uncurarized muscle stimulated directly, four maximal plateaus are often observed.

The second maximum is directly ascribable to the presence in these muscles of two substances differently affected by changes in temperature, by fatigue, and by drugs. Such changes in the whole muscle are marked by corresponding changes in the form of the single muscle curve, particularly in respect to the presence and relative importance of the two apices, which are almost characteristic of the gastrocnemius contraction curve. And with each change in the form of the muscle curve there is a corresponding change in the relative prominence of the two maximal plateaus in the series of contractions obtained with gradually increasing induction currents.

THE ACTION OF THE TWO-JOINT MUSCLES OF THE HIND-
LEG OF THE FROG, WITH SPECIAL REFERENCE TO THE
SPRING MOVEMENT.

BY WARREN P. LOMBARD.

BECAUSE of the peculiar relation of the two-joint muscles to the joints which they cross, any force, whether external or a muscular contraction, which flexes or extends hip, knee, or ankle, tends to

cause a like movement of the rest. These effects are produced by the passive, tendon-like action of the two-joint muscles, and are increased by their contractions. It is possible for any of the joints to be moved independently, where the two-joint muscles as a whole are not contracting. These muscles are attached under very little tension, and are sufficiently extensible to yield to even a comparatively slight stretching force. A single joint can therefore be flexed or extended by the action of one-joint muscles or by the action of a two-joint muscle when the other end of the muscle is prevented by one-joint muscles from moving the other joint which it ordinarily controls. *A two-joint muscle may indirectly cause the extension of the joint of which it is a flexor.* This may occur under the following conditions: *a.* The muscle in question, A, must have a better leverage at the end by which it extends, than at the end by which it flexes. *b.* There must be on the opposite side of the leg a two-joint muscle, B, which flexes the joint which A extends, and extends the joint which A flexes. *c.* The extensor leverage and strength of A must be sufficient to enable it to make use of the tendon action of B. *When all the two-joint muscles are acting at the same time, the energy developed by these muscles is transmitted as by an endless chain, having the form of a figure 8, with the crossing at the knee, and the effect progresses in the direction of the greatest leverage.* A preliminary series of typical curves of the leverage exerted by each end of all the two-joint muscles, and by the one-joint muscles of the knee and ankle, was shown. In general, these curves are in harmony with the view advanced as to the tendon action of the two-joint muscles in the spring movement. Not only is the leverage of the two-joint muscles when the leg is flexed in favor of the extending tendon action described, but as the leg approaches extension the leverage of many muscles changes, extension power lessening and flexion power increasing. The effect of this is to protect the joints and favor the recovery from the spring. Finally, it may be said that the action of many of the two-joint muscles, and at least of one of the one-joint muscles, may be reversed as the leg passes from flexion to extension. A muscle which acts to flex a joint in one position may extend it in another, and even flex it again in still another. This fact demands caution in the classification of muscles as flexors and extensors.

THE TONUS OF HEART MUSCLE.

BY W. T. PORTER.

THE following facts were demonstrated by graphic records:

1. As the tonus increases the conductivity of heart muscle diminishes. For example, the latent period of an extra-contraction produced between two spontaneous tonus contractions was ten-hundredths second, while the latent period of an extra-contraction produced near the summit of a spontaneous tonus contraction was sixteen-hundredths second.

2. The height of the tonus contraction is proportional to the strength of the stimulus. The law of "all or none" does not apply.

Induced current in Kronecker units (successive stimulations).	Height of tonus con- traction in millimetres (auricle of tortoise).
3500	7 mm.
3500	7 mm.
3000	5 mm.
4000	11 mm.
5000	25 mm.

Similar results were obtained with the ventricle, but the changes were less marked.

3. The tonus contraction has no refractory period. Extra-contractions (both of tonus form and fundamental form) may be produced during any phase of tonus contraction.

4. Tonus contractions may be superposed as contractions of skeletal muscles are superposed.

5. Summation of sub-minimal stimuli of tonus contractions was not secured, though many efforts were made.

The induced currents employed inhibited the spontaneous fundamental contractions. The spontaneous fundamental contractions regained their former height only after several contractions in "staircase" form.

THE EFFECT OF EXTIRPATION OF THE GASSERIAN GANGLION UPON THE SENSE OF TASTE.

By HARVEY CUSHING.

As the result of observations upon clinical cases, it has been found by many observers that lesions which have involved the fifth nerve have almost invariably been associated with a loss of taste over the corresponding side of the tongue.

The writer has given especial attention to the loss or preservation of taste in fourteen cases of extirpation of the Gasserian ganglion, and the uniformity of the results in this long series of cases seems to justify the conclusion that the trigeminal nerve does not serve as a path of transmission for these fibres. In one case only a single observation was made, namely, six days after the operation; the sense of taste was found to be lost. It probably returned subsequently, but this was not proved. In a considerable percentage of the other cases a similar loss or diminution in the acuteness of taste has been observed at a corresponding time after the operation. It has been found, however, that after a period of some days, taste always returns, even though a condition of anæsthesia to pain, touch, and temperature invariably persists after the extirpation. It seems not impossible that the degeneration taking place after the ganglion extirpation in the fibres of the lingual nerve, which are so intimately associated with the fibres of the chorda tympani, may in some way interfere for the time being with the normal transmission of taste impulses by way of the chorda. It is possible also that this degeneration may produce toxic substances which for the time being act directly upon the chorda fibres as a physiological "block" to their normal activities. However this may be, it has been found, contrary to the observations of Gowers, Stewart, Turner, and others, that the extirpation of the Gasserian ganglion affects in no way taste upon that portion of the tongue presided over by the glossopharyngeal nerve, and has only a temporary effect in a small percentage of cases in diminishing the perception of taste over the anterior two-thirds or chorda territory of the tongue.

SALIVARY DIGESTION IN THE STOMACH.

BY W. B. CANNON AND H. F. DAY.

EVIDENCE was brought forward in 1898 by Dr. Cannon¹ that Beaumont's and Brinton's theories of mixing currents in the stomach were not true. The food in the fundus, over which peristaltic waves do not pass, is not mixed with the gastric secretions. Since free hydrochloric acid does not appear in this part of the stomach for an hour or more, salivary digestion may continue during that time uninterrupted by the acid of the gastric juice. To study further the possible difference between carbohydrate digestion in the active pyloric end and in the quiet cardiac portion of the stomach, this research was undertaken.

Crackers free from sugar were used as food. In all cases a uniform amount of crumbed crackers was mixed with a uniform amount of saliva sufficient to make a thick mush. This food was either mixed a little at a time, and given at once to a cat to swallow, or mixed and introduced by means of a stomach tube. The animals were allowed to live one-half, one, or one and a half hours after eating. They were then quickly etherized, the abdomen was opened, and a ligature tied tightly between the cardiac and pyloric portions of the stomach. The pylorus and cardia were next tied, and the stomach then removed.

The contents of the stomach were received in evaporating dishes. The pyloric contents were invariably fluid; the cardiac contents often retained their shape so that it was possible to get the internal and external food of the region. After enzyme action had been stopped by bringing the food to the boiling point, the food was evaporated to dryness over steam. The dry mass was then powdered, and the sugar content estimated according to Allihn's method.

The results show that at the end of an hour the sugar present in the cardiac contents averages almost twice that present in the pyloric contents, and may be two and a half times as much. When the food is liquid, the ratio is diminished, *i. e.*, it is about six to five instead of two to one. Also, when small amounts of food are given, the sugar content is about the same in both parts of the stomach. Two cases in which the stomach was massaged at intervals during digestion showed a larger amount of sugar in the pyloric end than in the cardiac end. The largest amount of sugar, estimated as maltose, which has been found in the stomach contents, is about 49 per cent.

¹ CANNON: This journal, 1898, i, p. 375.

ON THE ELEMENTARY COMPOSITION OF ADRENALIN.

By JOHN J. ABEL.

THE fact that adrenalin is so easily convertible into the alkaloidal modification suggests at once that a simple relationship exists between these two modifications of the blood-pressure-raising principle. As prepared by the zinc-ammonia process already described,¹ washed entirely free of ammonia and dried in vacuo over sulphuric acid, adrenalin is found to be a stable product as long as it is kept perfectly dry. As made by this process, redissolved in dilute hydrochloric acid, and reprecipitated with ammonia, its composition was found to be:

C = 57.39 to 57.60,
H = 6.29 to 6.77,
N = 7.38 (KJELDAHL-GUNNING).

After nine precipitations with ammonia or sodium carbonate, its composition changed to:

C = 58.61 to 58.67,
H = 6.77 to 6.84,
N = 7.08 (KJELDAHL-GUNNING).

These results are such that a formula could be deduced from them, viz., $C_{10}H_{13}NO_3 \cdot \frac{1}{2}H_2O$; but unfortunately it was later discovered that the Kjeldahl-Gunning method fails to give all of the nitrogen of the compound, and these results are therefore only of value as showing that repeated precipitation raises the carbon content of the compound.

Commercial adrenalin was now purchased in several 100-grain lots and purified by shaking its hydrochloric acid solution with ether, and by repeatedly precipitating it from an acid solution with ammonia or sodium carbonate. More than thirty analyses have been made, but it has been found impossible to secure uniformity of composition among the various fractions.

Setting down all of the variations in respect to C, H, and N in the form of a table, we find that the extremes in respect to each element, run from —

C = 56.53 to 58.89,
H = 4.77 to 7.19,
N = 7.59 to 10.65 (DUMAS).

¹ Johns Hopkins Hospital bulletin, November, 1901, and February-March, 1902.

A very low hydrogen content, as 4.77, 5.05, 5.46, was less frequently met with than figures that went over 6 per cent, but these low hydrogen percentages were found to occur with high as well as with low percentages of carbon, and generally with high percentages of nitrogen. The precipitations with alkalis were repeated as many as ten times.

It is very evident then that adrenalin cannot yet be spoken of as having a "constant composition" (Takamine), and as being a pure chemical individual.

The writer has found that the substance, purified as far as possible by the above processes, is soluble to a very considerable extent in warm oxalic ethyl ester, and that it may be precipitated from this solvent by the free addition of ether, in the form of a water-soluble oxalate. It is hoped that this and other methods of purification will soon enable the writer to determine the true elementary composition of adrenalin and its exact relationship to the earlier epinephrin series.

ON THE BEHAVIOR OF EXTRACTS OF THE SUPRARENAL GLAND TOWARD FEHLING'S SOLUTION.

BY JOHN J. ABEL.

A PURIFIED extract of both beeves' and sheep's suprarenal glands, which are rich in the blood-pressure-raising principle, behaves in the following manner toward Fehling's solution. If an aqueous solution of the extract is poured into an excess of boiling Fehling's solution (Fehling I to water $\frac{1}{2}$) and the mixture is kept at the boiling point for two minutes and then cooled, no cuprous hydrate or cuprous oxide settles out. A flocculent, greenish-white copper compound will be found suspended in the fluid, or deposited on the bottom of the flask. After boiling from five to six minutes, a considerable reduction occurs, and after boiling for fifteen minutes, the reduction appears to have reached a maximum, and a heavy deposit of yellow cuprous hydrate, with possibly a small admixture of cuprous oxide, is obtained.

After precipitating the adrenalin with sodium carbonate from a given portion of extract, the filtrate, contrary to the statements of Aldrich, also gives a very abundant precipitate of yellow cuprous hydrate when boiled with Fehling's solution for from six to fifteen

minutes. Such a filtrate is estimated to contain from 15 to 20 per cent of adrenalin, and the amount of reduction obtained is apparently proportional to this unprecipitated adrenalin.

While extracts of the gland require prolonged boiling in order to effect complete reduction, salts of epinephrin or adrenalin are oxidized with the greatest ease and *rapidity* when brought into contact with a hot Fehling's solution; the reaction indeed begins far below the boiling point. V. Fürth's iron compound has also been found to reduce Fehling's solution on being boiled with it for a sufficient length of time.

It was clearly stated in a former paper¹ that epinephrin in its *native, unaltered state, as found in extracts of the gland, and as contained in v. Fürth's basic lead precipitate*, failed, in my hands, to reduce Fehling's solution, but that *my own compounds of epinephrin, as obtained in various ways, all agreed with adrenalin in their ability to reduce this reagent; and that, in this particular, there was no difference between them.*

ON THE OXIDATION OF EPINEPHRIN AND ADRENALIN WITH NITRIC ACID.

By JOHN J. ABEL.

RESULTS thus far obtained would indicate that the products obtained in the oxidation of epinephrin, $C_{10}H_{11}NO_3$, and adrenalin are identical. The following example will illustrate the process:

In very small portions at a time, 10 grams of purified adrenalin are dissolved in 60 c.c. of nitric acid, sp. gr. 1.2, in a platinum bowl on the water bath. The oxidation goes on with great violence, and care must be taken to avoid loss of material due to foaming. When the solution is complete, and the evolution of gases has largely subsided, 10 c.c. of fuming nitric acid is added, and the whole is concentrated on the water bath, water being added from time to time as the mass begins to thicken.

After this treatment has been continued for some hours, the contents of the dish, on cooling, are found to consist of a solid mass of odorless crystals. The larger part of this crystalline material con-

¹ See pages 337-338, and Conclusions 1, 2, and 3 of Summary, on page 343, Johns Hopkins Hospital bulletin, 1901, xii; also: *idem*, July, 1897.

sists of oxalic acid. The barium, lead, sodium, and calcium salts of this acid were prepared, as also its di-ethyl ester. The calcium salt, as prepared from the sodium salt, was found to contain 27.39 per cent Ca, the theoretical amount for $\text{CaC}_2\text{O}_4 \cdot \text{H}_2\text{O}$ as prepared from hot concentrated solutions of sodium oxalate by precipitation with calcium chloride. The tetragonal crystals, $\text{CaC}_2\text{O}_4 \cdot 3\text{H}_2\text{O}$, were also prepared, and the acid was shown to behave toward potassium permanganate and other reagents as does oxalic acid.

The other chief product of the above-described oxidation consists of a hygroscopic, crystalline salt (oxalate?) of the nitrogenous base to which reference has frequently been made and which I have called the coniine-piperidine-like body, on account of its peculiar, offensive, and penetrating odor. This part of the molecule has apparently remained entirely intact. Further treatment with iodine trichloride does not destroy it, but enables one to obtain it in the form of slender prisms, very soluble in water and alcohol, and little soluble in ether. The addition of an alkali to these crystals liberates the peculiar odoriferous base, exactly as if it had been added to epinephrin itself. If these crystals, or those obtained in the first place from the use of nitric acid, are fused with powdered potassium hydrate, an odor like that of pyrrolidine is obtained, later this gives place to the fishy odor of amines, and later still only pyrrol itself is evolved. In its behavior toward other destructive chemicals, as when fused with zinc dust, it also reminds one of the behavior of certain pyrrol derivatives under similar circumstances.

ON THE INFLUENCE OF CAMPHOR INGESTION UPON THE EXCRETION OF DEXTROSE IN PHLORHIZIN DIABETES.

By H. C. JACKSON.

THE work of v. Mering, Minkowski, Cremer, Lusk, etc., has shown that in phlorhizin and pancreatic diabetes there exists a definite ratio between the amount of dextrose and nitrogen eliminated by the kidneys. This D : N ratio is 2.8 : 1 in all cases except that of the dog in phlorhizin diabetes, where it is 3.75 : 1. The feeding of camphor to a dog made diabetic with phlorhizin, and upon which the relation 3.75 : 1 had been obtained, immediately decreased the D : N ratio to 2.8 : 1, or equal to that prevailing in all other animals with phlorhizin, and in the dog in pancreatic diabetes.

Microscopical examination of the kidneys of dogs fed with camphor alone, showed marked morphological changes in the cells of the ascending loops of Henle, the fatty infiltration or degeneration being limited to this group of cells and not diffuse, as is the case of phlorhizin poisoning. In some cases of phlorhizin poisoning, albuminuria sets in, and Lusk has noticed that in such cases also the ratio of D : N fell to 2.8 : 1 from 3.75 : 1. This may be explained by the supposition that phlorhizin in extreme cases causes changes in the cells of the loops of Henle similar to those induced by camphor and with similar results.

This decrease in ratio amounts to 25 per cent of the absolute amount of the sugar eliminated, and it seems probable that this fractional part of the total carbohydrate excretion is not present in the blood in the same form in which it appears in the urine, but suffers in some way a change into dextrose as it is excreted by the cells of the loops. When these degenerate, as under camphor treatment, they refuse to functionate, and the amount of sugar as compared to nitrogen appearing in the urine is decreased, and consequently a fall in the ratio is noticed. The remaining 75 per cent of carbohydrate is evidently eliminated unchanged.

The evidence seems favorable to the view of a double origin of the dextrose excreted in the urine in phlorhizin diabetes.

THE TOXICITY OF EPINEPHRIN (ADRENALIN).

BY SAMUEL AMBERG.

THE toxicity of epinephrin was tested in experiments on dogs with intravenous, subcutaneous, and intraperitoneal injections. A dose of 2.0 mgm. per kg. intravenously proved sufficient to kill an animal. One dog with 0.99 mgm. per kg. survived. The injections were made quickly. Animals which had been subjected to a chloroform asphyxia succumbed during the first few minutes following the injection. When the animals were in good condition, a longer time elapsed before death ensued. One animal, which had received a dose of 4.9 mgm. per kg. subcutaneously, survived, while one with 6.0 mgm. per kg., and others with more, died. The fatal dose by intraperitoneal injections lies, according to Herter, between 0.5 and 0.8 mgm. per kg.

Upon the heart action the drug exercises an influence by an initial

stimulation of the vagus, followed by a paralysis. Besides that, it has a direct injurious effect on the heart, as well as on the respiration. The pathological changes produced by the drug consist in hemorrhages, which were observed in the heart, lungs, intestines, peritoneum, in and around the pancreas, liver, adrenal glands, and thymus glands.

THE INFLUENCE OF THE H ION IN PEPTIC PROTEOLYSIS.

By WILLIAM J. GIES.

THE fact that pepsin shows digestive power only when acid is present implies the dependence of the enzyme upon hydrion for its activity. It has frequently been observed that various acids are efficacious in this connection, though in different degree.

In some recent experiments on the influence of acidity, I have used purified fibrin, edestin, and elastin as the indicators. Undigested residue, neutralization precipitate, and uncoagulable products were determined quantitatively in each digestive mixture. Various common mineral and organic acids were employed. Varying proportions of pepsin and acid were taken in uniform volumes (100 c.c.), with the same amount of proteid (1 gm.).

In *equipercantage* solutions of acids whose anions have no precipitative effect on proteid, the relative proteolysis is very different, being greatest in "strong" acids such as HCl, and least in "weak" acids, such as $\text{CH}_3 \cdot \text{COOH}$. *Equimolar* solutions of the same acids gave more concordant results in some respects, although the differences between the effects in such acids as HCl and $\text{CH}_3 \cdot \text{COOH}$ were still very wide. With *equihydric* solutions, the results showed greater harmony, though there were still striking divergences. H_3PO_4 , HCl, HNO_3 , HClO_3 , H_3AsO_4 , and $(\text{COOH})_2$, in strengths equivalent to decinormal KOH (with 50 mgm. of pepsin preparation, in 100 c.c. at 40°C ., four hours), showed practically the same ability to assist pepsin in the digestion of 1 gm. of fibrin.

Additional experiments, especially with *equidissociated* solutions of the acids referred to above, are expected to show the influence not only of hydrion, but also of the anions, if the influence of the latter in the acids referred to be appreciable. Similar experiments are about to be extended to other enzymes.

SOME OBSERVATIONS ON THE COAGULATION OF MILK.

By A. S. LOEVENHART.

THERE is a stage in the rennin coagulation of milk when boiling causes a coagulum to separate. The milk acquires the property of yielding a heat coagulum before there is any apparent alteration in the consistency of the milk. This represents a stage in coagulation of milk whether the rennin be of gastric or pancreatic origin. The term "metacasein reaction," introduced by Roberts, may be conveniently retained to signify this heat coagulation. The interval between the time the metacasein reaction may be obtained, and the spontaneous coagulation, varies inversely with the amount of rennin acting. Thus it may be so transient that it cannot be detected, or it may be prolonged indefinitely. The metacasein stage may be prolonged by any agency partially fixing the calcium salts, as by boiling, by adding small amounts of ammonium oxalate, etc.

The addition of larger amounts of ammonium oxalate entirely prevents any heat coagulation. Hence soluble calcium salts are necessary for the metacasein reaction. If at the metacasein stage the rennin be destroyed by heating at 75° for five minutes, the addition of calcium chloride at 40° causes the separation of a coagulum. This shows that at the metacasein stage the caseinogen has been largely transformed into paracasein. Fresh milk cannot precipitate paracasein solutions, nor can it prevent the precipitation of paracasein by calcium chloride. From these facts, it would appear that the calcium salts in milk are altered in some way during the action of the rennin, and by virtue of this become capable of precipitating paracasein.

It seems most probable that the calcium salts of the milk are very loosely combined with some constituent of the milk, and that these compounds are dissociated during the action of the rennin.

NEW INDUCTORIUM, KYMOGRAPH, HEART LEVER, HEAVY
MUSCLE LEVER, AND SQUARE RHEOCHORD.

By W. T. PORTER.

INDUCTORIUM.

THIS instrument (Fig. 1) is made entirely of hard rubber and metal. The *primary coil*, wound with double silk-covered wire of 0.82 mm. diameter, having a resistance of 0.5 ohms, is supported in a head-

piece bearing three binding posts and an automatic interrupter. The core consists of about ninety pieces of shellacked soft iron wire. This core actuates the automatic interrupter. The interrupter spring ends below in a collar with a set screw. By loosening the screw, the interrupter with its armature may be moved nearer to or farther from the magnetic core. Once set, the interrupter will begin to vibrate as soon as the primary circuit is made. The outer binding posts are used for the tetanizing current. The left-hand outer post and the middle post are used when single induction currents are desired; they connect directly with the ends of the primary wire,

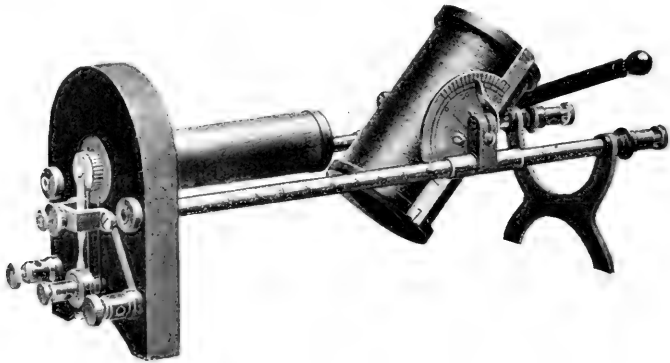

FIGURE 1.—The inductorium.

thus excluding the interrupter. These several connections upon the head-piece are simply arranged and are all in view; there are no concealed wires.

From the head-piece extend two parallel rods 22 cm. in length, between which slides the *secondary coil*, containing 5000 turns of silk-covered wire 0.2 mm. in diameter. Over each layer of wire upon the secondary spool is placed a sheet of insulating paper. Each end of the secondary wire is fastened to a brass bar screwed to the ends of the hard rubber spool.

The brass bars bear a trunnion which revolves in a split brass block, the friction of which is regulated by a screw. The trunnion block is cast in one piece with a tube 3 cm. in length, which slides upon the side rods. The secondary spool revolves between the side rods in a vertical plane. When the secondary coil has revolved through 90°, a pin upon the side bar of the secondary coil strikes against the trunnion block and prevents further movement in that direction. The right-hand side bar bears a half-circle graduated

upon one side from 0° to 90° . An index-pointer is fastened upon the trunnion block. One side rod is graduated in centimetres.

The side rods end in the secondary binding posts, so that moving the secondary coil does not drag the electrodes. Next the binding posts is placed a substantial "knife-switch" short-circuiting key, with hard rubber handle.

The dimensions of the inductorium are as follows: Length, 24 cm., breadth, 7 cm., height of head-piece, 9 cm., total weight, 650 gms. Excepting the magnetic core, interrupter spring, and armature, the metal used is brass, heavily nickelled and polished.

KYMOGRAPH.

The kymograph (Figs. 2 and 3) consists of a drum revolved by clockwork and also arranged to be "spun" by hand.

The *drum* is aluminium, cast in one piece, turned true in the lathe to a circumference of 50 cm. The height is 15.5 cm. The weight is 600 gms. The drum slides upon a brass sleeve in bearings 1.1 cm. deep (to prevent "side-lash"), and is held at any desired height by a spring clip (Fig. 2). The sleeve ends in a friction plate, which rests upon a rubber-covered metal disk driven by the clockwork. Sleeve and friction plate revolve about a steel shaft which passes through both the heavy plates containing the clockwork, and is securely bolted to the bottom plate. The sleeve bears upon the steel shaft only by means of "bushings" at the ends of the sleeve, thus securing a bearing without "side-lash" and with little friction. As the sleeve with the drum rests upon the friction plate by gravity alone, it is easy to turn the drum by hand either forward or back, even while the clockwork is in action. This is a great convenience. At the top of the sleeve is a screw ending in a point which, when the screw is down, bears upon the end of the steel shaft and lifts the sleeve, and with it the drum, until the sleeve no longer bears upon the

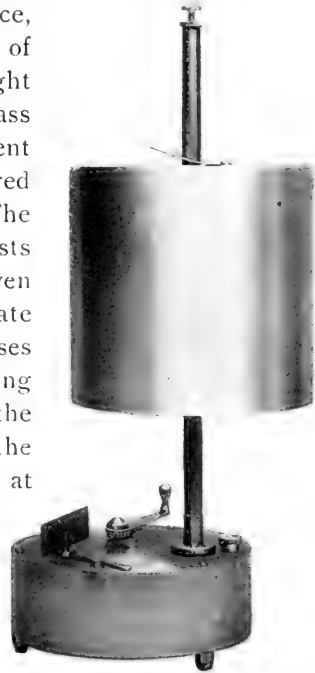

FIGURE 2.—The kymograph and its aluminium drum.

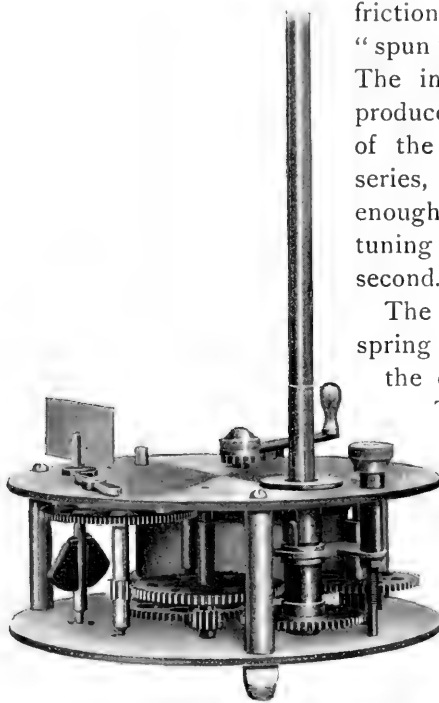

FIGURE 3. — The kymograph, showing clockwork and steel shaft.

friction plate. The drum may then be "spun" by hand about the steel shaft. The impulse given by the hand will produce from seven to ten revolutions of the drum. In the middle of the series, the movement will be uniform enough to give a fair record with a tuning fork vibrating 100 times per second.

The *clockwork* consists of a stout spring about 6 metres in length, driving the chain of gears shown in Fig 3.

The speed is mainly determined by a fan slipped upon an extension of the last pinion shaft in the chain. Four fans of different sizes are provided.

The speed is regulated by a governor consisting of two metal wings fastened to the same shaft that carries the fan. When the milled head shown in both figures to the

Fan.	Length. Cm.	Height. Cm.	Total hours run upon one winding.	Speed in mm. per second at measured intervals.
None	$\frac{3}{4}$	Ten-minute intervals : 50.0 50.0 44.0 36.0
1	34	23	1	Ten-minute intervals : 38.0 38.0 36.0 30.0
2	68	23	$2\frac{1}{2}$	Ten-minute intervals : 17.0 16.0 16.0 16.0 16.0 16.0 15.0 15.0 15.0 14.0 13.0 11.0
3	102	23	5	Half-hour intervals, beginning at 10th minute : 8.0 8.0 8.0 8.0 8.0 7.0 7.0 6.0
4	102	46	7	One-hour intervals, beginning at 10th minute : 5.8 5.8 5.7 5.4 5.1 4.5

right of the steel shaft is up, as in Fig. 3, the gear shown on the extreme right no longer engages with the gear driven by the spring, but runs "idle," while the gear attached to the friction plate engages with the lower of the two gears shown at the left; the pinion of this lower left-hand gear engages with the spring gear. Fast speeds are then obtained as indicated in the table on page xxxviii.

When the milled head is down, as in Fig. 2, the gear attached to the friction plate falls below the left-hand gear, while the right-hand gear engages with the spring gear and through a pinion drives the friction-plate-gear. Slow speeds are then obtained as follows :

Fan.	Length. Cm.	Height. Cm.	Total hours run upon one winding.	Speed in mm. per second at measured intervals.
1	34	23	1	Ten-minute intervals: 2.6 2.5 2.3
2	68	23	2½	Half-hour intervals, beginning at 10th minute: 1.0 1.0 0.9 0.8
3	102	23	5	Half-hour intervals, beginning at 10th minute: 0.51 0.50 0.50 0.49 0.48 0.47 0.45 0.43
4	102	46	7	Half-hour intervals, beginning at 10th minute: 0.40 0.39 0.38 0.38 0.38 0.37 0.36 0.35 0.34 0.33 0.33 0.28

Larger fans may be used. Thus, a fan 14 cm. long and 9 cm. high will give one revolution (50 cm.) per hour.

In both figures, the brake, the winding lever, and stop-pin are shown upon the upper plate.

Each shaft and its pinion is one piece turned from the same solid piece of steel. All the parts are highly polished.

HEART LEVER.

This very light lever (Fig. 4) is used in the suspension method of recording the contractions of the heart, or for



FIGURE 4. — The heart lever.

similar purposes. The axle is 7 mm. in length. The axle, with its aluminium wire 22 cm. long, and foil writing point 3 cm. long, weighs only 0.4 gram. All the parts except the lever are brass, heavily nickelled and polished.

HEAVY MUSCLE LEVER.

It is sometimes necessary to afterload a muscle lever with weights far in excess of those that a light muscle lever will bear without "springing" and thus altering the abscissa. Such heavy loads are borne by the heavy muscle lever illustrated in Fig. 5. A cast-iron tripod, 27 cm. high and 17.5 cm. broad at the base, supports a femur clamp and a muscle lever. The latter is a steel tube 5 cm. long, pierced by a steel axle 9 mm. long, revolving between heavy brass posts. The lever weighs 2.5 gms. The aluminium scale-pan weighs 20 gms.; it holds one hundred 10-gram weights. The lever may be turned completely over in a backward direction and thus be entirely out of the way. The steel spring shown upon the left of Fig. 5 may then be turned to the right to bring its wire hook into the opening through which the scale-pan is reached. The scale-pan may then be attached to this *isometric spring* and the spring empirically graduated. When the graduation scale has been written, the milled screw that holds the isometric spring upon the left-hand post (Fig. 5) may be loosened, the spring turned with the hook up, and the screw made fast again. The lower end of the muscle may now be attached to the hook upon the spring and an isometric curve written.

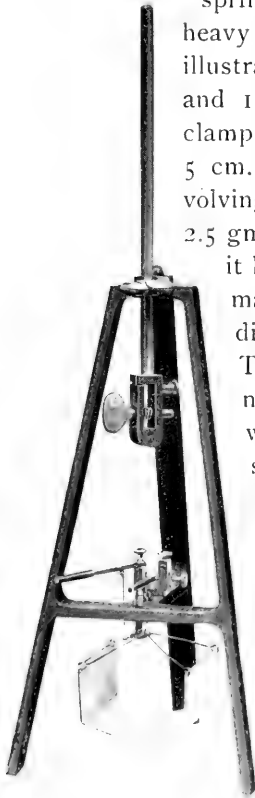

FIGURE 5.—The heavy muscle lever.

The screw clamp holding the muscle clamp is insulated. A binding post upon the muscle clamp, and another binding post upon the right-hand post supporting the axle of the lever, allow direct stimulation of the muscle.

SQUARE RHEOCORD.

The rheocord, or potential divider, illustrated in Fig. 6, is a block of hard maple, 12.5 cm. square, upon which is placed a centimetre scale beginning at the 0-post shown on the left side of the figure and ending at the 1-metre post visible in the background to the left. Along the scale, between these two posts, is stretched the first metre of a continuous German silver wire, 0.26 mm. in diameter and 20 metres long. The remaining 19 metres of this wire are coiled upon a spool, and the free end is fastened to the 20-metre post shown in the background to the right of Fig. 6. The resistance in the 20 metres of German silver wire is so great (about 184 ohms) that the internal resistance of the element furnishing the electromotive force, together with the resistance of the large copper connecting wires, practically disappears for ordinary measurements.

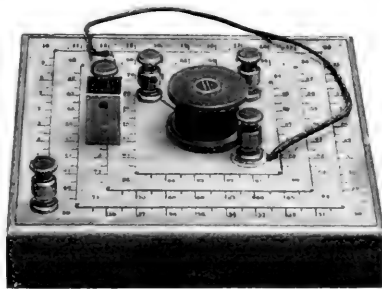

FIGURE 6. — The square rheocord.

As the fall of potential is uniform throughout the 20 metres, the difference of potential between post 0 and post 1 will be practically one-twentieth the electromotive force of the element. By moving the contact block from post 1 toward post 0, any desired fraction of this one-twentieth may be secured. The under surface of the contact block is bevelled so that the metal touches the wire only with one edge; the opposite edge is supported by a piece of hard rubber.

A flexible cable leads from the contact block to the binding post shown in the foreground to the right :

DEMONSTRATION OF THE MOVEMENTS OF THE STOMACH AND INTESTINE OBSERVED BY MEANS OF THE RÖNTGEN RAYS. By W. B. CANNON.

ON THE NUCLEOPROTEIDS OF THE PANCREAS, THYMUS, AND SUPRARENAL GLAND, WITH ESPECIAL REFERENCE TO THEIR OPTICAL ACTIVITY. By ARTHUR GAMGEE AND WALTER JONES.

This journal, 1903, viii, p. 447.

ON THE ORIGIN OF THE RELATION OF THE INORGANIC ELEMENTS TO PROTOPLASM. By A. B. MACALLUM.

OSMOTIC CHANGES IN THE SACRAMENTO SALMON DURING THE RUN FROM THE SEA TO THE SPAWNING BEDS. By C. W. GREENE.

Read by title.

AN IMPROVED APPARATUS FOR ILLUSTRATING THE ACTION OF THE DIAPHRAGM. By B. G. WILDER.

By invitation.

A LIVING FROG FROM WHICH THE CEREBRUM WAS REMOVED DECEMBER 4, 1899. By B. G. WILDER.

By invitation.

QUICK METHODS FOR THE CRYSTALLIZATION OF THE OXYHÆMOGLOBIN OF THE BLOOD OF THE DOG AND CERTAIN OTHER SPECIES. By E. T. REICHERT.

INHIBITORY PHENOMENA IN THE CRYSTALLIZATION OF OXYHÆMOGLOBIN. By E. T. REICHERT.

THE VASOMOTOR INFLUENCE OF THE THIRD CERVICAL NERVE (AURICULARIS MAGNUS) UPON THE CIRCULATION IN THE RABBIT'S EAR. By S. J. MELTZER and CLARA MELTZER.

ON THE XANTHIN BASES OF THE SUPRARENAL GLAND. By W. JONES.

Read by title.

THE INFLUENCE OF NEPHRECTOMY UPON ABSORPTION. By S. J. MELTZER and W. SALANT.

ON THE SOURCES OF MUSCULAR ENERGY. By W. O. ATWATER.

STUDIES ON THE INFLUENCE OF ARTIFICIAL RESPIRATION UPON STRYCHNINE SPASMS AND RESPIRATORY MOVEMENTS. By S. J. MELTZER and W. J. GIES.

This journal, 1903, ix, p. 1.

THE EFFECT OF THE INTRAVENOUS INJECTION OF ADRENALIN UPON THE BLOOD-VESSELS OF THE EAR WHEN DEPRIVED OF THEIR VASO-CONSTRICTORS. By S. J. MELTZER and CLARA MELTZER.

THE UNMISTAKABLE VASOMOTOR INFLUENCE OF SUBCUTANEOUS INJECTION OF ADRENALIN. By S. J. MELTZER and CLARA MELTZER.

With demonstration.

ARTERIAL BLOOD-PRESSURE IN THE SACRAMENTO SALMON, ONCORHYNCHUS TSCHAWITSCHA. By C. W. GREENE.

Read by title.

THE ACTION OF HÆMOLYTIC AGENTS AT 0°C. By G. N. STEWART.

Read by title.

DIFFERENCES OF POTENTIAL BETWEEN BLOOD AND SERUM AND BETWEEN
NORMAL AND LAKED BLOOD. By G. N. STEWART.

Read by title.

THE LAKING OF DRIED BLOOD-CORPUSCLES. By G. N. STEWART, for
Dr. CLAUDE C. GUTHRIE.

This journal, 1903, viii, p. 441.



THE
American Journal of Physiology.

VOL. VIII.

OCTOBER 1, 1902.

NO. I.

ON THE FUNCTIONS OF THE CEREBRUM: I.—THE
FRONTAL LOBES IN RELATION TO THE PRODUCTION
AND RETENTION OF SIMPLE SENSORY-
MOTOR HABITS.¹

By SHEPHERD IVORY FRANZ.

[*From the Physiological Laboratory of the Harvard Medical School.*]

CONTENTS.

	Page
Introduction	1
Methods	5
Surgical procedure	5
The determination of habits	6
Experimental	10
Retention of habits after extirpation of both frontal lobes	10
Retention of habits after other lesions	13
Formation of associations after removal of both frontal lobes	16
Additional observations	20
Summary	21

I. INTRODUCTION.

THE present research was undertaken to determine, if possible, the relation of the various so-called association areas of the cerebrum to simple mental processes. The experiments to be reported in this paper are concerned mainly with the frontal area.²

¹ A preliminary account of this investigation was read at the Baltimore Meeting of the American Psychological Association, December, 1900. Psychological review, 1901, viii, p. 163.

² Later, papers will be published upon the parietal and temporal association areas and upon the motor and sensory zones.

It is known that the electrical stimulation of certain regions of the cerebrum produces no demonstrable results, and that these regions may be extirpated usually with little alteration in the sensory endowments of the animal and in its mental state. Thus the removal of the occipito-temporal regions or of the parietal association areas produces comparatively no change in the animal's behavior. The changes noted after the extirpation of the frontal lobes vary greatly according to different experimenters. According to some investigators the animals deprived of the frontal portions of the cerebrum are apathetic, stolid, or idiotic; others have found such animals ugly, irritable and restless. Occasionally all these terms have been used to describe the effect in one animal. These various descriptive words have been taken by some to mean a loss in ability to attend to the usual conditions of the mental stream, in other words, the loss of a supposed "faculty" of attention. Such a conclusion seems unjustified, however, since it would separate the attention process from all mental states. In reality the attention is only a characteristic of mental conditions.

For the better understanding of the present state of our knowledge regarding the functions of the frontal lobes I may cite the following accounts and conclusions.

Loeb, who has recently written a general account of brain functions,¹ says: "I have repeatedly removed both frontal lobes in dogs. It was impossible to notice the slightest difference in the mental functions of the dog. There is perhaps no operation which is so harmless for a dog as the removal of the frontal lobes" (p. 275). In a discussion of the differences between the frontal and occipital portions of the cerebrum, he remarks, "And if the anterior parts of both hemispheres be removed, the dog is no longer normal, but idiotic" (p. 263). "While dogs after the loss of the anterior halves of the cerebral hemispheres often become irritable and ugly, dogs which lose the occipital halves of both hemispheres invariably become good-natured and harmless" (p. 264).

In a careful review of the physiology of the cerebral cortex, Schäfer writes as follows: "It is more easy to produce a condition of semi-idiotcy in monkeys from extensive bilateral lesions of the temporal lobes than from complete severance of the prefrontal region, an operation which may indeed be effected without producing any very obvious symptoms. . . . I have in several cases completely removed,

¹ LOEB: Comparative physiology of the brain and comparative psychology.

in the monkey, the whole of the inexcitable areas of both frontal lobes without producing the slightest sign of the mental and intellectual dulness and alteration of character which has been regarded as pathognomonic of a lesion of this region.”¹

The results of the early experiments made by Ferrier,² are mostly open to the objection that secondary softenings often followed the extirpations, and that usually a condition of sepsis was present. In addition the animals lived for only a very few days, and possibly had not sufficiently recovered from the primary shock effects of the operation. Ferrier's later experiments with Yeo,³ however, are free from these objections, and the results may here be briefly mentioned.

In a baboon the occipital lobes were extirpated. No impairment of vision seemed to follow this operation, and the animal to all intents was mentally normal. Six months after this operation the frontal lobes anterior to the pre-central sulcus were extirpated. “In less than an hour the animal began to move about, though in a somewhat sleepy and listless manner. . . . Only its manner seemed changed (*i. e.*, after some days), and this was noted by all who had seen its former vivacity. It lost all its fun and trickiness, seemed not to know its name, took little or no interest in its companions, and was very easily cowed by them. Psychically only it had undergone appreciable change and dégradation” (p. 481). This animal was observed three months before being killed. In a second monkey the whole convex surface of both frontal lobes was cauterized. “No physiological defect could be discovered, nor could any very definite alteration in the animal's behavior be determined. It seemed only less timid of its companions. . . . Till its death by chloroform, eleven weeks later, it continued in perfect health and exhibited no perceptible deviation from the normal” (p. 525). The bases of both frontal lobes in another monkey were cauterized. On the third day a dreamy or drowsy condition was maintained, and on the seventh day the animal was still dull, taking no interest in anything but its food. “Except for general dulness and want of interest in its surroundings, the animal exhibited no perceptible effect of the operation and continued in excellent health” (p. 528). Seven weeks after

¹ Text-book of physiology, edited by E. A. SCHÄFER. Article on Cerebral Cortex by the editor.

² FERRIER: *Philosophical transactions of the Royal Society*, 1875, clxv, p. 433.

³ FERRIER and YEO: *Ibid.*, 1884, clxxv, p. 479.

this first operation both frontal lobes were wholly excised and the same general dulness was noted. "Apart from a degree of dulness or apathy — and this as time went on not particularly noticeable — there was nothing in the animal's behavior at all remarkable or appreciably abnormal." The authors draw the following general conclusions from the results of their experiments: "As to the psychical effects of the frontal lesions it is difficult to speak at all definitely. In some cases there was no marked change, yet in others . . . there was a manifest alteration in the character of the animal. On the whole there seemed mental deterioration, characterized by general apathetic indifference or purposeless unrest, effects which, in comparison with those of other lesions, appear to have relation with lesions of the frontal lobes as such" (p. 531).

Hitzig¹ and later Horsley and Schäfer² have given more definite facts regarding the mental condition of animals after frontal lesions. The first investigator had a dog which had been accustomed to find its food upon a table in the room and to take the food therefrom. In psychological terms we may say there had been formed in the brain of the dog the association "table — food."³ The sight of the table and possibly the smell of both table and food would produce a nervous impulse resulting eventually in a complex motor response of going to the table, getting up to the food, and taking it. In this dog after the frontal lobes had been extirpated the habit was lost. Even after all primary effects of shock had had time to pass away the animal did not associate (or so it seemed) with the complex of sensations which we call table the appropriate muscular movements. In fact the association of table — food was lost. A record of a similar observation upon a monkey has been recorded for us by Horsley and Schäfer, but is negative in this respect. These experimenters had a monkey which exhibited in its normal condition certain well-defined simple habits, or as the authors call them "tricks." After both

¹ Quoted by FERRIER: *Functions of the brain*, 2d ed., 1886. HITZIG'S original article is not accessible at the time of writing this account.

² HORSLEY and SCHÄFER: *Philosophical transactions of the Royal Society*, 1888, clxxix, p. 1.

³ The writer does not wish to enter into a discussion of the mental states of animals, and the consideration of association of ideas, etc., in animals is left to the comparative psychologist. For the most conservative accounts of the mental life of animals the reader is referred to the various writings of LLOYD MORGAN and THORNDIKE.

frontal lobes were removed, the monkey still retained the habits. The tricks were shown as well after as before the operation.

The important and significant fact that the reader should bear in mind is that in these two cases and in the case of Ferrier and Yeo mentioned above (case of the baboon which forgot its name, p. 3) we have a very definite mental state, in each animal a particular association which in two cases was lost and in the other was retained after removal of the frontal lobes. It will be well to note that in none of the cases have we information of how long before the operation the associations were formed. The lack of this detail, I believe it will be shown later, makes the experiments comparable to only a slight extent. In a subsequent portion of this article it will be noted that the duration of an association should perhaps be considered of prime importance.

The experiments which form the basis of the present article are similar to those of the cases just considered. My endeavor has been to determine whether or not simple sensory motor habits were affected by removal of the frontal lobes. In certain ways the research may be considered an extension of Hitzig's experiment, although it was undertaken and fully planned before Ferrier's account came to my notice.

METHODS.

Surgical procedure:— A general anæsthetic (ether, ether and alcohol, or the alcohol-chloroform-ether mixture) was used in all operations and continued in every case until the animal was ready to be taken from the operating table. In some cases, in addition, there was given by mouth a quantity of urethane, chloral hydrate, or chloretone sufficient to keep the animal quiet after the operation for a sufficiently long time to prevent unnecessary movements which might cause hemorrhage.

In all operations the usual aseptic precautions were taken. Before the scalp incision was made the hair was cut and the scalp thoroughly washed with a solution of 1 : 500 bichloride of mercury or with 5 per cent carbolic acid. In only one animal was pus found, and this was undoubtedly due to infection after the operation. This animal tore off the bandage and scratched the wound. However, although pus was found beneath the scalp, it had not gone into the brain.

A half-inch trephine was used to make the opening through the skull and sometimes the opening was subsequently enlarged by means of bone forceps. Generally, however, the button was taken from a point immediately over the portion of the brain which was to be excised. After the button was taken out it was kept in warm saline and replaced before the scalp was stitched. This procedure in addition to a tight bandage kept an equal pressure on the part of the brain exposed and helped to prevent hernia.

After the button was lifted out the dura was cut to expose the cortex. Then with a fine cataract knife an incision was made at the point selected. When a frontal or an occipital lesion was made the knife was pushed down until it struck the base of the skull. With a gentle movement it was pulled outward, but toward the side so that the particular portion should be cut away from the main part of the hemispheres. The portion cut away was allowed to remain within the cranium. This method recommended by Schäfer tends to prevent hernia of the fibrous portion of the cerebrum by keeping the cranial capacity normal.

Bleeding from the diploë and from the brain was checked as much as possible by the application of artist's wax to the diploë and of compresses to the cerebrum. In most cases the head bandage was sewed together to prevent its being torn away by the animal.

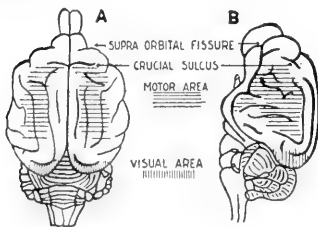

FIGURE 1.—A, superior, and B, lateral aspects of the brain of a cat. Adapted from Wieder and Gage, and from Ferrier.

The accompanying diagram of the cat's brain shows the location of the sensory and motor functions. The frontal region, I consider as that portion anterior to the crucial sulcus. By prefrontal would be meant the portion before the supraorbital fissure.

The determination of habits.—The method employed for the production of simple associations is that used by Lloyd Morgan¹ and more extensively by Thorndike² and other writers. Briefly described, the method is as follows: An animal is placed in a certain environment, usually unpleasant or indifferent to the animal. By a simple motor

¹ C. LLOYD MORGAN: Introduction to comparative psychology; Habit and instinct; Animal life and intelligence.

² E. L. THORNDIKE: Psychological review, 1898, Supplement No. 8; *ibid.*, 1901, Supplement No. 15

adjustment the cat or the dog or the monkey gets a subsequent pleasure.

At first the motor response is neither accurate nor speedy. At the beginning of any series of experiments the animal makes random movements according to its nature, scratching, pulling, biting, and feeling everywhere. By chance it hits upon the proper movement, and after the experiment has been repeated a number of times the unnecessary movements are eliminated. Only those movements are retained which tend to make the pleasure come soon, and consequently the time in which the act is performed gradually decreases. Usually after twenty or thirty trials the response is received immediately after the animal is placed in the desired environment.

The activity of the animal is well described by Thorndike: "When put into the box the cat would show evident signs of discomfort and of an impulse to escape from confinement. It tries to squeeze through any opening; it claws and bites at the bars or wires; it thrusts its paws through any opening and claws at everything it reaches; it continues its efforts when it strikes anything loose or shaky; it may claw at things within the box. It does not pay much attention to the food outside, but seems simply to strive instinctively to escape from confinement. The vigor with which it struggles is extraordinary. For eight or ten minutes it will claw and bite and squeeze incessantly. . . . The cat that is clawing all over the box in her impulsive struggle will probably claw the string or loop or button so as to open the door. And gradually all the other non-successful impulses will be stamped out, and the particular impulse leading to the successful act will be stamped in by the resulting pleasure, until, after many trials, the cat will, when put in the box, immediately claw the button or loop in a definite way."¹

In the present research only cats were used, and the environments were similar to those used by Thorndike, viz.: boxes from which the animal could escape by pulling a string, pressing a button, etc. Escape from the box always meant "food." The boxes were about twelve inches high, fifteen inches deep, and twenty inches long. An illustration of one of these is shown in Fig. 2, p. 8. The bottom, back, and sides of the boxes were solid boards, the front and top were made by placing three-quarter inch slats about an inch apart except at the door. The door was about six inches wide and eight inches high, hinged at the bottom, and so arranged that it

¹ THORNDIKE: *Animal intelligence*, p. 13.

would fall outward when the button was properly pressed, or the cord suitably pulled. In addition to the box here illustrated, two other boxes were used. Both of these were manipulated by a cord attached to a bolt at the top of the door. In one the cord passed upward and over the top of the box to the back where it was

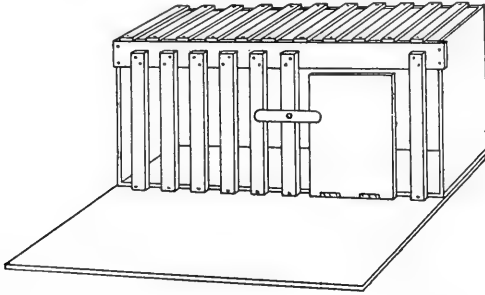

FIGURE 2. — Box from which animal could escape by pressing the button down or up. This box is hereafter called *button*.

fastened. In this box at the place where the cord passed over the box a wire netting was arranged about three-quarters of an inch above the cord. The door would fly open if the cord was pulled by the paw or if the head was strongly brushed against it. The cord on the other box passed upward and then downward and outward to

a point about three inches to one side of the door and about two inches in front of the slats. The animal could escape from this box by strongly pulling or pressing against the cord. In the remainder of this article these boxes will be called respectively, *Button*, *String above* and *String front*.¹

The cats were placed in the boxes when hungry, food was placed outside and each cat was watched until it had opened the door and had obtained the milk or meat or fish. A record was kept of the time of escape at each trial, — and the speed together with the elimination of random movements determined for me when the habit was learned.

The retention of the association under any set of conditions may be learned by placing the animal in the box under such circumstances. If the time remain the same as when the original experiments were made, we may be warranted in saying that the habit is retained, and if the time be somewhat longer or the motor response not so accurate we may obtain a fair idea of how well or how ill the habit has persisted.

The accompanying table and figure (Fig. 3) will illustrate the

¹ For many other similar arrangements the reader is referred to the monographs of THORNDIKE, where a full discussion of results with such environments will be found.

method and at the same time indicate the retentiveness of a cat for the simple habit *String front*.

TABLE I.

String front. Female cat about six months old. Active.

Feb. 5, 3.00 P. M.	Feb. 19, 4.50 P. M.	March 25, 3.50 P. M.
8 secs.	5 secs.	2 secs.
33 "	7 "	1 "
222 "	3 "	2 "
68 "	2 "	2 "
200 "	6 "	1 "
10 "	Feb. 22, 3.10 P. M.	April 10, 3.10 P. M.
113 "	8 secs.	2 secs.
Feb. 7, 1.23 P. M.	3 "	3 "
24 secs.	5 "	2 "
25 "	5 "	2 "
17 "	3 "	2 "
43 "	March 3, 3.15 P. M.	
14 "	2 secs.	
3 "	3 "	
3 "	2 "	
6 "	2 "	
3 "	3 "	
6 "		

Applying similar tests in the present investigation, if there be no alteration in the mental condition of an animal subsequent to the removal of the frontal lobes, the time of escape should be as short after the operation as it was before. The "memory" curve should be the same as in a normal cat. If, on the other hand, there has been a psychical disturbance, loss of memory may be found, ranging from a complete failure to a slight slowing in the time of performance.

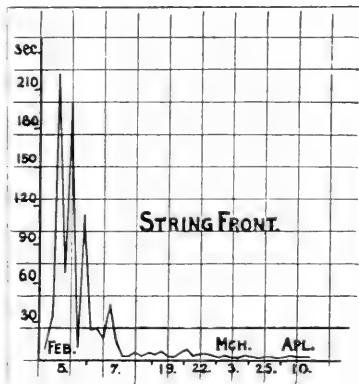

FIGURE 3. — Curve of acquisition and retention of simple association.¹

¹ Numerous similar curves will be found in THORNDIKE'S Animal intelligence, pp. 18-26. He has found that in many of his animals — cats, dogs, chicks — there is almost perfect memory, or to speak more accurately, perfect retentiveness of habits for periods as long as seventy days.

EXPERIMENTAL.

Retention of habits after extirpation of both frontal lobes.—In Hitzig's experiment¹ we have seen that the dog could not find its food upon the table after the removal of the frontal areas. In terms of physiological psychology we may say that the association of table—food with the appropriate motor response had been lost. A similar result was obtained from all the cats operated upon by me in the same manner. The following cases will, I think, be sufficient to establish the fact.

- I. Cat 4. Very active, female, four to five months old.
- Oct. 8. Experiments begun, *Button* and *String above*.
- Oct. 15. These habits had been thoroughly learned, so that the cat escaped from either box in times of one, two, and three seconds.
- Oct. 17. A. C. E. mixture. Both frontal lobes excised. Later in the day the cat seemed in good condition, but on the following day it seemed dazed and would not eat. However, it followed me about the animal room when called (this habit, it will be noted, was not lost). When returned to its cage it appeared restless.
- Oct. 19. Two days after the operation, the animal seemed in much better condition. It ate well and nothing unusual was noted about it. When tested regarding its retentiveness of the habits previously formed, it appeared that these were lost.
- Oct. 20-25. During the following six days the animal was tested in both boxes, but there appeared no evidence of retentiveness. At this time observers said the cat appeared mentally the same as a normal animal.
- Oct. 26. Unfortunately, signs of distemper appeared, and the animal was killed to prevent contagion.

During the progress of the experiments, after the operation it was noticed that when put in the boxes the cat would put its nose or its paws through the slats, and it would scratch around just as it had when learning the habit. To all who observed the cat at this time it seemed that no memory of the habits was present. It is interesting to note, however, that on Oct. 23, six days after the operation, the cat succeeded in escaping from the *String above* box by crawling out of the top. In all the boxes a top slat was left unfastened as a convenient method of introducing the animal into the box. In this case the cat accidentally pushed aside the slat, and when this was noted immediately crawled out of the box. In the experiments before the operation this slat was kept down by a brick or by the experimenter's foot, so that no memory can be said to have been present of such

¹ See above, p. 4.

association. Accidentally the slat was pushed aside by the head or back, and it was some time before notice was taken of it and escape effected.

Another observation of interest is in regard to emotional states. In the animal room there was a cage of mice. Immediately before the operation every cat was held in front of this cage and its reactions noted. In this cat, as in the others, the same sort of response was obtained after the operation as before it. The cat's heart beat more rapidly, its eyes followed the movements of the running mice, and it repeatedly tried to jump from my arms upon the cage in order to obtain its prey. This may also be considered as another example of the retention of a long-standing or of an inherited habit.

On post-mortem examination the brain was found normal except where the lesion had been made. The place where the cut had been made was well within the frontal areas. No hernia of the brain could be noted.¹

This case is typical of all the other experiments upon the frontal lobes, and it is important that the reader keep in mind the following three facts: (a) the recently formed habits of opening the box by the string appear to be lost after extirpation of the frontal lobes; (b) the impulse (or we may say the inherited habit) to escape from an enclosed space remained perfect under these conditions; (c) the habit of coming at call — an association of comparatively long duration — was retained.

II. Cat 5. Active female, six to seven months old.

Oct. 8. Experiments begun, *String front* and *String above*.

Oct. 15. Average time for escape from these boxes, two and one half and six seconds respectively.

Oct. 16. Extirpation of both frontals. Ether + 0.75 gm. chloral hydrate by mouth. For three days after the operation the cat was drowsy and apathetic. When taken from the cage it would walk a few steps and then stop. It seemed to have no objection to wetting its paws.

Oct. 19. On this day it appeared quite like a normal cat, but when put in the boxes to determine memory, it showed no signs of retentiveness. Its activities were similar to those of a cat that had not been in the boxes before. After this date, and until the cat was killed, Oct. 28, nothing unusual was noted in the behavior of the animal, except that it did not retain the habits.

¹ My friend, Dr. H. N. KINGSFORD, has kindly consented to investigate and report upon the pathological findings in all the brains, in respect to both gross and microscopical changes. In this article, accordingly, only the changes apparent to the eye will be noted.

My note of Oct. 20 in regard to *String front* is of interest: "In a general way the cat seems to remember the place where its paw should be put to get at the cord, but the paw is placed only between the slats, not through them." By "remember" I here meant that there were more impulses at or near the appropriate space through which the cat should have put its paw. To open the door, it will be remembered, it was necessary to push the paw about two inches through the bars.

III. Cat 9. Active female, about eight months old.

Nov. 1. Experiments were begun, *String front* and *String above*.

Nov. 16. Both habits were fully formed; the times for escape average three and five seconds respectively. Normal memory was tested two weeks later, with averages of two and one half seconds for the *String front* and six seconds for the *String above*. Although the habit was perfect, the animal was further practised at intervals of three days until the operation.

Dec. 10. Operation. Ether + 0.3 gm. chlorotone. The animal had a good recovery after the extirpation and on the following days seemed quite normal. It followed me about the room, but when placed in the boxes the appropriate responses were not obtained. It moved around within the box, scratched in different places, put its paws between the bars, and several times had a paw in the proper place to pull the string. In these cases, however, it did not complete the motor process. The impulses to escape were practically the same as in a normal cat, but perhaps a trifle less active. Until it was killed, about two weeks after the operation, it showed no signs of retentiveness of the habits.

The emotional effects before and after the operation were the same as in the preceding case (Case I).

IV. Cat 11. Active female, about nine or ten months old.

Nov. 15. Experiments were begun, *Button* and *String above*. These were perfect on Nov. 24, but the animal had developed distemper. From this it had recovered by Dec. 10, when retentiveness was found to be excellent (seventeen days' interval). Its memory was tested again on Jan. 22 (thirty-nine days' interval); the habits were retained.

Jan. 22. Operation. Five hours after the operation the animal appeared normal except for a little drowsiness, occasioned, undoubtedly, by the 0.5 gm. chloral which was given after the operation.

Jan. 23. When put on the floor it responded to my call, but could not escape from the boxes. Some slight inaccuracies of adjustment in walking were noted on this day, but these disappeared by the next day. They may have been due to the chloral.

Jan. 24-29. The cat was placed in the boxes each day, but during this period, although the cat was active, no evidence of retention of habits was shown,

With this cat and the others, if the animal did not escape from the box after two minutes the trial was considered a failure and no further attempt was made on that day. This was an arbitrary selection by me, but I think that it was justified. Such an interval of time enabled the animal to escape if the association was retained, but may not have given time for the cat to hit the button or string in its random movements.

After Jan. 29 the cat slowly *relearned* the habit. This matter will be more fully considered in a later portion of this article.

At first sight it may seem proper to conclude from these and the other similar experiments that the frontal lobes are concerned in the production and the retention of simple sensory-motor habits. But a very valid objection may be urged against considering the matter settled by these experiments alone. To a critic all that the results would indicate is that habits are lost when the integrity of the brain is destroyed. Whether the loss is due to "surgical shock" or to the destruction of that part of the brain concerned in the mechanism is not decided by the experiment. Such a criticism is equally potent against considering as conclusive the experiments of Hitzig, of Ferrier and Yeo, and of Horsley and Schäfer.

Retention of habits after other lesions. — Accordingly, the next step to be taken was the examination of the effects of "surgical shock" and of the loss of other portions of the hemispheres. Let us first consider one typical case in which the operation was carried to the point of destruction of a part of the brain, but stopped there. In this experiment the animal was etherized as usual, the skull was trephined in two places, the dura was cut. The brain was not cut. Then the scalp was stitched together and the animal placed under observation.

IV. Cat 14. Active male, about nine months old.

Dec. 1. Experiments were begun, *String front*.

Dec. 5. Habit well acquired. The average time for performance on this day was two and two thirds seconds. At 1.45 the operation was performed as described above. Fifteen minutes after the operation the cat walked about the room with fully coördinated movements but seemingly a trifle "drunk" from the ether. No test of the memory was made on this day.

Dec. 6. Twenty-four hours after the operation the cat was placed in the box and gave the appropriate motor response as readily as on Dec. 5. Average time of ten trials, two and one half seconds. No change in the behavior of the animal was noted from the time of the operation until it was killed five weeks later. The post-mortem examination showed a normal brain, uninjured about the points at which the trephine buttons had been taken.

Other similar experiments were performed but in none were the habits lost. These are sufficient, I believe, to indicate that the loss of the habit when the frontals are excised is not due to the general shock effects of the operation, — ether, loss of blood, etc. Moreover, the animals were tested upon the day succeeding operation, when the effects of shock would be greatest. Even under these adverse conditions the associations were always retained. It would seem proper to conclude that an operation as such has little or no influence upon the retentiveness of these simple habits.

But, it may be urged, may not the loss of the cerebral substance produce a greater nervous shock and thus explain the loss of the associations? The following four cases answer this question:

- V. Cat **17** and VI. Cat **29**. Both active males, respectively about six and seven months old. Cat **29** was practised in *Button* and *String above*, and Cat **17** in *String front* and *String above* until the habits were perfect. Then both cats were operated upon; the left parietal was excised. In the parietal region the area extirpated was between the motor zone and the visual area.
- Jan. 24. Operation on Cat **17**. In the parietal region about $\frac{3}{4}$ sq. cm. was destroyed. For an hour after the operation the animal seemed weak, and for the remainder of the day was very restless.
- Jan. 27. Three days after the operation the cat was tested to determine retentiveness. On this day it escaped from *String front* in five, four, nine, nine, and eleven seconds, while before the operation it had opened the door in five, two, three, two and three seconds. With the *String above* on the day of the operation it escaped in ten, six, four, three and six seconds, and on the third day after, the times were three, two, three, thirty-five and five seconds. In this case it is of interest to note that the habit formed in *String above* was pulling with the paw. The same response was obtained after the operation. Most of the cats had learned to arch the back or to raise the head and brush against the cord to raise the latch.
- March 12. The whole of the right frontal lobe was excised. On March 10 the cat had escaped in an average of two seconds from *String front*.
- March 16. Average time of escape, eighteen seconds.
- March 19. Average time of escape, thirty-two seconds.
- March 10. In *String above* escape was effected in 8 (H. P.),¹ 3 (N.), 5 (P.), 4 (P.), and 20 (N.) seconds.
- March 16. The times were 16 (H.), 22 (H. N.), 15 (N.), 8 (P.), and 16 (H.).

¹ These letters represent the portion of the body used by the animal to open door: H. = head; P. = paw; N. = neck. These were often used in combination.

March 19. Escape in 6 (N.), 12 (P.), 22 (H. N.), 8 (N.), and 15 (H.).

This cat, it will be noted, was slowly learning to change the motor adjustment from the paw to the head and neck, a procedure requiring less movement. The change is very marked after the operation.

Cat 29 was operated upon in a similar manner. At first only the left parietal was excised, and later the right frontal.

March 11. Excision of left parietal.

March 17 and following days it gave normal times for both boxes, *c. g.*, *String above*: March 11, two, four, five, two, and two seconds; March 17, five, six, three, two, and two seconds.

April 10. Extirpation of right frontal. After this date there was a lengthening of the time similar to that found with Cat 17.

April 17. *Button*, escape in thirty-five, seventy-five, thirty-four, six, and thirty seconds. *String above* in eight, six, five, three, and three seconds.

April 24. *Button*, two, six, fourteen, ten, three, four, and two seconds. *String above*, three, six, four, two, and two seconds.

During the days succeeding both operations the animals appeared well, no motor or sensory defects were apparent, and the cats were neither more nor less apathetic or listless than the cats not operated upon.

A third operation was performed on each cat (left frontal) but both died before the effect could be determined.

VII. Cat 23. Female, ten months old. *String front* and *String above* were learned and both parietals excised. Both associations were perfect before the operation and three days subsequent to it. Nothing of special interest was noted in this case. After the death of the cat the lesions were found to be about 8 mm. square.

VIII. Cat 35. Male, five to six months old. This cat was somewhat sluggish in its movements, and the time of escape was usually much longer than that of other cats.

By Dec. 15 it had learned *String front*, and on the following day the right frontal and the left occipital were excised. There was a quick recovery, and on the day after the operation the times were nearly the same as upon the preceding day.

A month later the left frontal was extirpated. Fifteen minutes after the operation the cat walked well, but seemed dazed, probably from the ether. Periods of apathy were noted occasionally after the second operation, although none were evident after the first. In general, however, the animal seemed intelligent and bright. Tested in the box on Jan. 17 and 18, the cat failed to open the door in five trials, although its activity was considerable. Its movements were very much the same as in a cat that had not been placed in the box before. The movements that were

made were not especially directed to the bars through which the cord could be pulled, but were the random movements of a cat trying to escape from confinement. Beginning with Jan. 19 the cat slowly regained the habit.

Formation of associations after removal of both frontal lobes. — If the frontal lobes are concerned in the production of these simple habits, it would be reasonable to suppose that such associations could not be formed after the removal of these portions of the hemispheres. The following examples indicate, however, that such is not the case.

IX. Cat 6. Very active female, about four months old. This animal was operated upon before any habits had been formed.

Oct. 2. Operation: extirpation of both frontals.

Oct. 5. When allowed to roam about the room it appeared normal, and when held up in front of the cage of mice it showed well marked emotional reflexes.

The experiments were not begun until two weeks after the operation.

Oct. 16. Experiments begun, *String front*. In three days the habit was fully formed. The cat was very active after the operation as well as before it, and showed no signs of restlessness or of apathy. From the actions of the animal it was impossible to determine that anything had been done to it. Two weeks later signs of distemper appeared, and the animal was killed on Nov. 2.

Post-mortem examination showed the brain lesion somewhat posterior to the crucial sulcus and very close to the motor area. No motor or sensory disturbances had been noted in the animal, however. Slight adhesions of the dura to the skull and of the dura to the brain were noted.

The formation of the habit is represented graphically in the accompanying curve, Fig. 4.

X. Cat 7. Active female, nine months old. No associations were formed before the operation.

Oct. 11. Both frontals excised. Nothing unusual noted in the animal's behavior after the operation. The cat was very lively during the succeeding days and showed no lack of general intelligence. Little emotional effect was noted, either before or after the operation, when the cat was held before the cage of mice. Fig. 4 gives a detailed account of the formation of the association *Button*.

The cat was killed Nov. 2. Post-mortem examination showed that the frontals had been cut away just anterior to the crucial sulcus.

Of more interest are the two following cases in which associations formed before an operation were lost after both frontals were taken

away, and then these same habits relearned. In one case, Cat 11, two successive operations upon the frontal areas caused successive loss of habits. After the second operation and loss the animal again learned the trick.

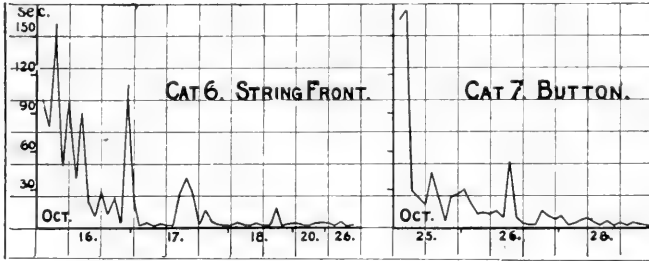

FIGURE 4. — Curves of the formation of habits. A, Cat 6, *String front*; B, Cat 7, *Button*.

VIII. Cat 35. (For an account of the behavior of this animal, see page 15.)
The accompanying table and figure give better than a description the progress of the cat throughout the experiment.

TABLE II.

Cat 35. *String front*.

Nov. 12, 9.00 A. M.	Nov. 15, 2.00 P. M.	Dec. 14, 10 A. M.
410 secs.	40 secs.	5 secs.
404 "	15 "	4 "
168 "	7 "	4 "
390 "	42 "	6 "
222 "	14 "	8 "
Nov. 13, 9.00 A. M.	Nov. 16, 6.00 P. M.	Dec. 14, 10.30 A. M.
95 secs.	8 secs.	Destruction of R. frontal and L. occipital.
142 "	7 "	Dec. 16, 4.00 P. M.
135 "	3 "	12 secs.
132 "	4 "	6 "
90 "	8 "	5 "
Nov. 14, 2.30 P. M.	Nov. 23, 10.00 A. M.	8 "
130 secs.	3 secs.	9 "
9 "	4 "	Dec. 18, 2.00 P. M.
12 "	5 "	4 secs.
5 "	4 "	3 "
10 "	4 "	6 "
10 "	Dec. 1, 9.30 A. M.	4 "
16 "	4 secs.	2 "
14 "	6 "	Dec. 18-Jan. 14.
60 "	4 "	Practised on habit.
23 "	5 "	
	2 "	

TABLE II (continued)

Jan. 14, 1.30 P. M.	Jan. 26, 3.30 P. M.	Jan. 30, 10.30 A. M.
Extirpation of L. frontal.	34 secs.	5 secs.
Jan. 19, 3.30 P. M.	8 "	6 "
Failure.	18 "	3 "
Failure.	46 "	3 "
Failure.	23 "	7 "
Failure.	Jan. 27, 1.40 P. M.	Feb. 4 11.00 A. M.
Failure.	8 secs.	3 secs.
Jan. 22, 2.30 P. M.	9 "	6 "
222 secs.	12 "	3 "
248 "	3 "	3 "
180 "	16 "	2 "
130 "	Jan. 28, 3.00 P. M.	Feb. 15, 4.15 P. M.
35 "	6 secs.	4 secs.
Jan. 23, 4.50 P. M.	9 "	3 "
95 secs.	4 "	2 "
128 "	8 "	2 "
63 "	6 "	6 "
140 "		Feb. 27
44 "		Died.

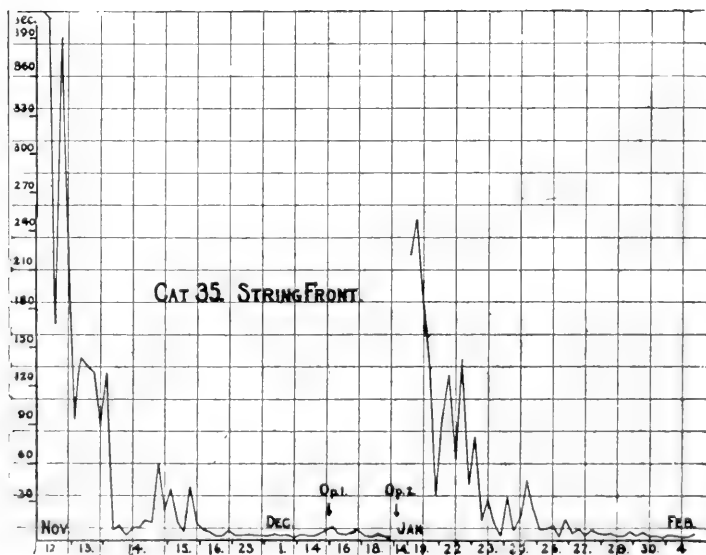

FIGURE 5. — Acquisition and retention of habit by Cat 35.

IV. Cat 11. This animal was operated upon Jan. 22, after having learned *Button*. (For remarks, see page 12.) This habit was lacking after the operation and was relearned. Then on Feb. 9 a second operation was performed immediately posterior to the first. For the ten days succeeding this operation there was no evidence of the persistence of the association. Two days after operation, when placed in the boxes, the cat walked up and down within, looking out between the bars but making no attempts to get out. On Feb. 14 this was continued. At times it stopped in its walk, looking steadily at some other cats in a near-by cage. It did not attempt to get at the button. It did not go passively into the box when I tried to put it in, as it used to do, but attempted to prevent my putting it in. Smell was present, but it is possible there was a slight anæsthesia of the fore-paws. Movements of walking were fully coördinated. The cat did not stand on its hind legs with any degree of stability when food was held up for it. Normal response when held in front of the cage of mice. When in the box, and fish was placed outside, there was noticed a lack of attention to all but the food. On Feb. 22 the cat began to relearn the association; but as it was practised only about once a week the process was comparatively slow. A full account is given in Table III and Fig. 6.

Post-mortem examination showed that the first lesions were posterior to the supraorbital fissure and the second lesions immediately behind the crucial sulcus.

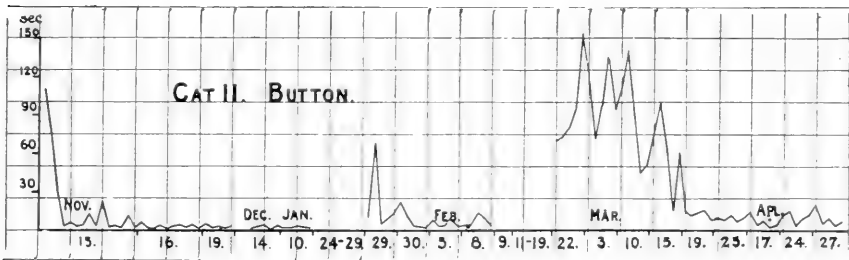

FIGURE 6. — Cat 11 in *Button*. Both operations were bilateral lesions in the frontal lobes.

TABLE III.

Nov. 15, 3.50 P. M.	12 secs.	Nov. 16, 11.30 A. M.
110 secs.	4 "	6 secs.
76 "	22 "	2 "
31 "	2 "	1 "
3 "	3 "	3 "
6 "	2 "	1 "
3 "	11 "	3 "
4 "	2 "	4 "

TABLE III (continued).

Nov. 16, 11.30 A. M.	Feb. 5, 2.00 P. M.	March 19, 4.10 P. M.
2 "	8 secs.	15 secs.
4 "	3 "	12 "
1 "	4 "	14 "
Nov. 19, 11.30 A. M.	10 "	15 "
5 secs.	3 "	9 "
2 "	Feb. 8, 2.00 P. M.	March 25, 3.40 P. M.
4 "	4 secs.	10 secs.
2 "	5 "	8 "
3 "	14 "	12 "
Nov. 22-Dec. 10.	10 "	7 "
Trials, nothing unusual.	3 "	10 "
Dec. 14, 1.50 P. M.	Feb. 9.	April 17, 3.00 P. M.
2 secs.	Second operation.	14 secs.
3 "	Feb. 11-19.	3 "
4 "	No evidence of habits.	7 "
1 "	Feb. 22, 3.30 P. M.	2 "
4 "	70 secs.	4 "
Jan. 10, 3.00 P. M.	73 "	Apr. 24, 2.30 P. M.
2 secs.	80 "	12 secs.
2 "	95 "	15 "
3 "	153 "	4 "
2 "	March 3, 2.20 P. M.	9 "
1 "	120 secs.	12 "
Jan. 22.	72 "	Apr. 27, 1.50 P. M.
Operation.	97 "	20 secs.
Jan. 24-28.	135 "	5 "
No evidence of habits.	95 "	9 "
Jan. 29, 11.20 A. M.	March 10, 11.30 P. M.	4 "
11 secs.	110 secs.	7 "
68 "	140 "	Sept. 21.
5 "	90 "	Died.
9 "	45 "	
13 "	52 "	
Jan. 30, 1.30 P. M.	March 15, 3.50 P. M.	
22 secs.	75 secs.	
11 "	100 "	
4 "	65 "	
3 "	16 "	
2 "	60 "	

No further discussion of these facts will be made at this time and the explanation is reserved for a future paper.

Additional observations. — *Emotional States.* In the preceding pages I have recorded cases in which the emotional responses were the same after as before the removal of the frontal lobes. All the cats that showed emotional signs when held in front of the cage of

mice before the operation were similarly affected after it. Several cats showed evidence of displeasure when handled somewhat roughly, and there was indication of feeling when unusual noises were produced. All the animals were as friendly after the operation as before it, — some probably more so. A few that tried repeatedly to escape from me before the operation, kept close to me afterward. Whenever I was among them after the operation, the animals would continually brush against my legs and purr as good-natured cats do. So far as these observations may be stated in general terms, I should say that the emotions remained practically the same after as before the operation, but that any change present was a tendency to greater friendliness.

Nutrition. — Almost all the cats used died of distemper. Two had been affected with mange for some time before death. On post-mortem examination, all animals but one were greatly emaciated, although the appetite was usually good. The fæces seemed normal, but no special chemical examination was made. The change in nutrition would lead us to believe that the frontal lobes may be concerned in that function. This result, I am aware, is opposed to Ferrier's experience with monkeys.¹ This investigator found that there were greater changes in nutrition after lesions in the occipital lobes, and that the frontal lobes seemed to have nothing to do with this function.

SUMMARY.

1. Cats may be taught simple sensory motor associations in from two to five days.
2. Memory for these habits persists normally for a period of from seven to eight weeks.
3. After a bilateral lesion in the frontal lobes the habits are lost.
4. This effect cannot be explained as due to "shock," for other brain lesions are not followed by loss of habits.
5. Unilateral lesions of the frontal areas are usually followed by a partial loss, or, rather, a slowing of the association process.
6. Habits once lost after removal of the frontals may be relearned. After a second operation they are again lost, and may be regained a second time.

¹ FERRIER: *Functions of the Brain*, 1886, p. 194.

7. Only newly formed habits are lost after such lesions. Inherited and long-standing habits seem to be retained.
8. The emotional condition of the animal is practically the same after as before the operation.
9. Emaciation and liability to disease were noted in all animals from which the frontal lobes were extirpated.

STUDIES ON REACTIONS TO STIMULI IN UNICELLULAR ORGANISMS. IX.—ON THE BEHAVIOR OF FIXED INFUSORIA (STENTOR AND VORTICELLA), WITH SPECIAL REFERENCE TO THE MODIFIABILITY OF PROTOZOAN REACTIONS.¹

By H. S. JENNINGS.

THE only infusorian whose behavior is at present known with any degree of fulness is *Paramecium*. This animal is a type of the free-swimming infusoria; while *Paramecium* does at times come to rest, as a rule it is found in rapid movement, — especially when under experimental conditions.

The behavior of an animal which is fixed in a definite position will necessarily be of a different character from that shown by such an organism as *Paramecium*. *Stentor* and *Vorticella* furnish examples of such animals, and, as will appear, their behavior differs much from that of *Paramecium*, — showing indeed a much higher development.

As compared with an organism continually in motion, a fixed animal offers many advantages for the experimental study of behavior, for one may keep the same individual continuously under observation, or return to it at longer or shorter intervals. It is thus possible to observe changes in behavior, and to determine whether the reaction to a given stimulus is modified by previous subjection to the same or different stimuli.

The present paper is based upon a study of the behavior of the following organisms: *Stentor ræselii* Ehr., *Stentor cæruleus* Ehr., several species of *Vorticella*, *Epistylis flavicans*, var. *procumbens*, and *Carchesium polypinum* Lin. *Stentor* is much more favorable for such work than any of the *Vorticellidæ*, and *Stentor ræselii* is in many respects the most favorable as well as the most interesting of the organisms studied. I shall therefore make an account of the behavior of this animal the basis of the paper, comparing the others with it.

¹ Contributions from the Zoölogical Laboratory of the University of Michigan, No. 57.

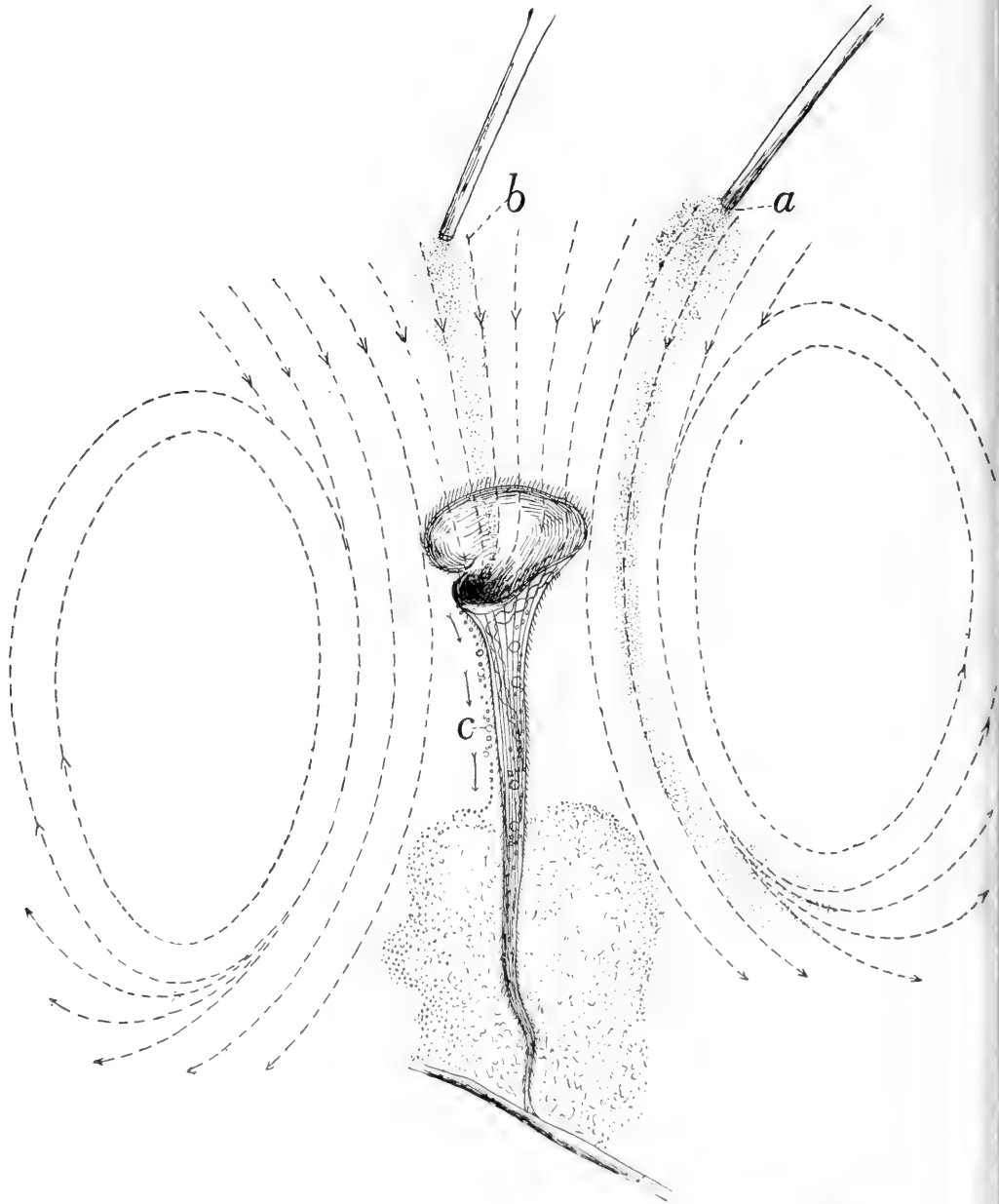

FIGURE 1. — *Stentor roeselii*, showing the currents caused by the cilia. At *a* a chemical is introduced a little to one side of the disc, showing that it does not reach the animal. At *b* a chemical is introduced above the disc; it is carried directly to the mouth. At *c* particles are seen passing along the ventral surface of the body to the edge of the tube.

A. THE BEHAVIOR OF *STENTOR RÆSELII* EHR.

For understanding the behavior of an organism when subjected to stimuli, it is necessary to have well in mind the structure of the animal and its normal movements when unstimulated, — a consideration too often neglected in work on behavior.

Stentor ræselii Ehr. (Fig. 1) is a colorless or whitish animal consisting, when fully extended, of a slender, tapering, stalk-like body, bearing at its larger end a broadly expanded disc. The surface of the body is covered with longitudinal rows of fine cilia, and bears also a considerable number of fine long setæ, which disappear at times, and are said to be retractile and extensile. The disc is surrounded by a circlet of large compound cilia or membranellæ. These make a spiral turn, passing on the left side into the large buccal pouch, which leads to the mouth. The mouth thus lies nearly in the middle of what may be called the oral surface; this surface is considered ventral in determining right and left. The disc is covered with rows of fine cilia which are nearly parallel with the circle of membranellæ. The smaller end of the tapering body is known as the foot; here the internal protoplasm is exposed, sending out fine pseudopodia, by which the animal attaches itself to objects (Fig. 2).

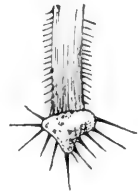

FIG. 2. — Foot of *Stentor ræselii*, after Johnson ('93), showing the pseudopodia.

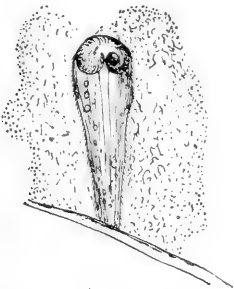

FIG. 3. — *Stentor ræselii*, contracted into its tube.

The body contains, next to the surface, many fine contractile fibrillæ, the myonemes, through the action of which the animal may contract into a short oblong or conical form (Fig. 3).

Stentor ræselii is usually attached to a water plant or a bit of débris by the foot, and the lower half of the body is surrounded by the so-called tube. This is a very irregular sheath, formed of flocculent material of all sorts, partly held together by a secretion from the *Stentor*. It is frequently nearly transparent, so as to be almost invisible. The manner in which the tube is formed will be described later.

Movements of cilia in the unstimulated animal.¹ — The membranellæ and cilia of the oral disc are in continual motion in the extended animal; the nature of this motion is best seen by adding something to the water to make the currents induced by the cilia visible. When finely ground sepia or carmine is added to the water, the currents caused by the cilia are seen to be as follows: The mouth of the animal forms the bottom of a vortex, towards which the water above the disc descends from all sides (Fig. 1). Only the particles in the water near the axis of the vortex really strike the disc, — those a little to one side shoot by the edges without touching. These latter curve outward again after reaching a point below the disc, and thus a whirlpool is produced, — some of the particles returning upward so as to reach again the downward current at a point some distance from the Stentor. But most of the particles which thus miss the edge pass downward and out of the sphere influenced by the Stentor.

Particles which reach the disc pass to the left, toward the buccal pouch, showing that the beat of the membranellæ has a component which drives to the left as well as downward, — the real movement of the current being thus a left spiral. The particles thus reaching the buccal pouch are whirled about within it a few times, then they may take one of two courses. They either pass down into the mouth at the bottom of the pouch and thus into the internal protoplasm, or they are whirled out over the edge of the pouch, in the mid-ventral notch. In the latter case they usually pass backward toward the foot of the animal, along the mid-ventral line, as shown at *c* in Fig 1. Apparently the body cilia in this region keep up a backward current. The particles reach the edge of the tube, where they may cling, thus aiding to build up the tube.

In determining whether certain given particles shall pass into the protoplasm or out over the edge of the disc, there seems to be no indication of sorting by the cilia and of choice, — though this would not be at all surprising in view of what we know of choice in *Amœba*, and of corresponding phenomena in inorganic fluids (see Rhumbler, 1898, or the brief resumé in Jennings, 1902). But in *Stentor*, as long as the disc remains extended, whenever particles of any sort are allowed to reach the disc in large numbers, some are taken into

¹ It is doubtless to be held that the animal is never really unstimulated; the use of this term signifies merely that no special stimulus is acting on the animal, beyond what is supplied by the usual conditions of existence.

the protoplasm, while others pass over the edge and away, without regard to the nature of the particles (provided they are not too large; see p. 30). This is true, for example, of sepia, carmine grains, unicellular algæ and débris of all sorts. When large numbers of minute unicellular algæ pass into the buccal pouch, apparently the proportion taken into the protoplasm is the same as in the case of sepia or other non-nutritious particles. It seems evident that whether a given particle shall or shall not be taken into the internal protoplasm depends upon the mechanical conditions governing the spiral currents in the pouch. Many of the particles in the current never reach the minute mouth at all, and these are whirled over the edge in continuation of their spiral course; those which are so situated in the vortex as to be carried directly to the mouth are taken in. Of course Stentor does exercise a sort of choice (as will appear below), by changing its position, reversing the ciliary current, or contracting when injurious substances are present in the water, but there is no indication of a sorting and selection of particles brought into the pouch by the usual currents.

When stimulated, *Stentor roeselii* may contract into its tube (Fig. 3). Such contractions do not as a rule take place except in response to well marked stimuli. This was the rule throughout my observations, extending over many days. Undisturbed individuals observed without interruption for an hour or more did not contract at all during that time. In this respect *Stentor* differs from *Vorticella*, which contracts at short intervals, even when the conditions are apparently quite uniform (see Hodge and Aikins, 1895).

Reactions to stimuli. I. Mechanical stimuli.—We will first consider what *Stentor* does when touched or struck by small objects,—its reactions to simple mechanical stimuli. Such stimuli are often received in the normal life of *Stentor*, and there is a surprisingly full and complicated set of reactions to them, as compared with the simple reactions of *Parmecium*.

We will suppose that small solid bodies are brought with the water currents to the disc. This may be controlled experimentally by drawing a glass tube to a long, excessively fine capillary point, filling the tube with water containing finely ground sepia, and bring the point near the *Stentor*. What the animal does depends upon a number of different conditions.

Normal movements continued.—At first the normal currents are not changed; the particles pass into the pouch, and some are taken

into the internal protoplasm, while others pass out over the edge of the pouch at the mid-ventral notch, as described above. If the particles are minute, do not cling together into large masses, are not excessive in number, nor mingled with any stimulating chemical, the currents continue this normal course indefinitely.

Bending toward the source of stimulus.—If a small object merely touches gently one edge of the disc, the Stentor may bend over

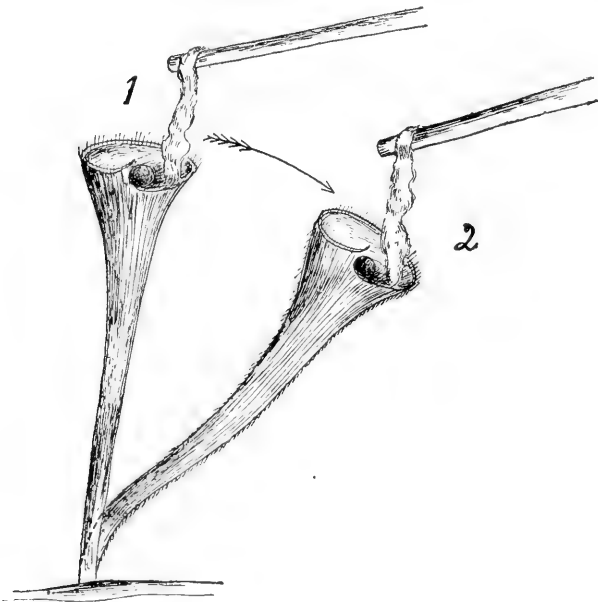

FIGURE 4.—*Stentor ræselii* bending in the direction of a slight mechanical stimulus. At 1 a bit of debris is allowed to touch the edge of the disc, and is then pulled to the right. The Stentor follows it, bending into the position shown at 2.

toward the object (Fig. 4). This reaction may be seen when a small organism comes against the disc of Stentor, then attempts to swim away. The Stentor bends in that direction, so as to keep in contact with the object as long as possible. In the culture dishes containing Stentors there were many free heads of *Epistylis*, and these frequently swam thus against the Stentors, giving rise to the above

described reaction. The *Epistylis* heads were not held at all, but were merely followed as far as possible by bending.

This reaction may be produced experimentally by tickling the edge of the disc with the tip of a minute glass rod drawn out to the finest possible hair.¹ The Stentor bends over toward the side touched, and if the rod is moved very gently to one side, follows it.

¹ These and similar manipulations were carried out under the Braus-Drüner binocular microscope, the use of which renders very simple many experiments and observations which would otherwise be difficult.

If the rod trembles a little too much, the Stentor will contract suddenly, as described below. The most satisfactory way of producing the reaction is to get a bit of soft flocculent débris from the bottom of the dish to cling to the rod. This débris may then be allowed to come against the disc, and is then gently pulled to one side. The Stentor follows it, often bending far over. This experiment is represented in Fig. 4. The animal may thus bend in any direction,—to the right, to the left, or toward the oral or aboral side.

Bending away.—If the stimulus is a little stronger, as one produced by a large hard object, or by the objects becoming too numerous, as when a dense cloud of sepia reaches the disc, or when the objects are accompanied by a weak chemical stimulus, as is the case with carmine grains, then another reaction is produced. The animal bends away from its present position. This is thus to a certain degree the opposite of the reaction last described, but is not so precisely localized a reaction as the former one. In this reaction the organism shows the influence of its spiral, unsymmetrical structure, in that, as in the case of Paramecium, it always turns toward a structurally defined side. The reaction in Stentor is as follows: the animal twists on its long axis one or two turns, then bends over toward the aboral side. It thus bends into a new position, but it does not always bend *away* from the source of stimulus; in some cases this reaction carries the animal toward the source. In the latter case the reaction is repeated.

In most cases where the source of stimulus is not large, this reaction succeeds in removing the Stentor from its action. Thus, if a capillary tube containing sepia is held close to the disc, when the animal bends over toward the aboral side the particles of sepia no longer reach the disc, and the animal is relieved from the stimulus (Fig. 5). Much experimentation shows that this simple reaction is more effective in getting rid of stimuli of all sorts than might be anticipated. If the first reaction is not successful in accomplishing this end, it is repeated.

Reversal of the ciliary current.—If the turning toward one side does not relieve the animal (or in some cases before this is tried), so that the particles continue to come in a dense cloud, the ciliary current is suddenly stopped and apparently reversed for an instant. The particles in the pouch or against the disc are thus thrown off. The reversal lasts but an instant, then the current is continued. If the particles still continue to come, the reversal is repeated two or

three times in rapid succession. If this fails to relieve the animal of the stimulus, the next reaction (contraction) usually supervenes.

Sometimes this reversal of the current takes place before the turning away described above, and it may be followed by that reaction. But usually the turning away occurs first.

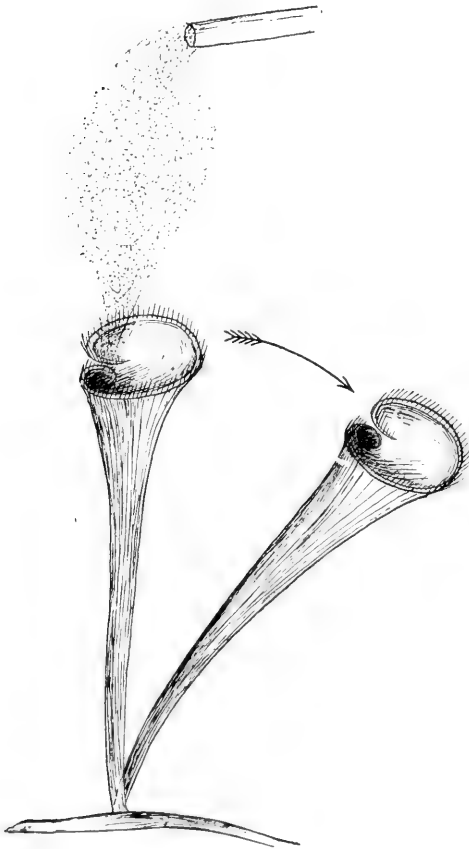

FIGURE 5.—*Stentor rœselii* bending away when a quantity of sepia or of some chemical reaches the disc. The animal bends toward the aboral side.

The reversal is produced under various circumstances. It occurs when a very large number of particles reach the disc at once, so that there is a tendency to clog the pouch, or when a large hard object, such as one of the loricate Ciliata, gets into the pouch. I have seen Coleps gotten rid of in this way. It occurs also when some chemical, as a weak salt solution, is mingled with the particles, or when the chemical alone reaches the disc (see the reactions to chemical stimuli, below).

Contraction.— If the animal does not succeed in getting rid of the stimulus in either of the ways above described, or if the stimulus is a very powerful one to begin with, the *Stentor* suddenly contracts. The body becomes short and club-shaped or oblong, and the *Stentor* disappears within its tube (Fig. 3).

Here it usually remains twenty to thirty seconds, then rather slowly extends, so that from the moment of contraction to the moment of complete extension an interval of 40 to 50 seconds has usually elapsed.

When, in extending, the body of the Stentor has become about half or two-thirds its original length, the ciliary disc begins to unfold and the cilia to act, causing the current to reach the disc as before. If with the current the stimulus again acts upon the animal (as when the sepia or the chemical is kept near), immediate recontraction follows.

This may be repeated many times. To certain sorts of stimuli, as will be seen later, Stentor may get accustomed, so as to unfold and behave in the usual manner while the stimulus continues undiminished. We will consider for the present the case where the continuance of the stimulus involves continued repetition of the reaction. This case is realized when a dense cloud of carmine grains is kept where it will strike the Stentor as soon as it expands, or when various chemicals are kept in this position. In such a case the contractions are repeated, as above described, usually for a period of ten to fifteen minutes. Often the animal, after a number of contractions, remains within its tube a longer time than at first. But more often there is little change in the time of contraction until toward the end of the period of ten or fifteen minutes. If the stimulus continues, the next phase of the reaction now sets in, described in the following.

Abandonment of the tube.—After the stimulus has been thus repeated at every unfolding of the Stentor for ten to fifteen minutes, the animal contracts violently several times, without intervening full extension. The short clavate body merely lengthens a little, then contracts suddenly and powerfully into a still shorter mass. This is repeated until the attachment of the foot of the Stentor at the bottom of the tube is broken, and the animal is free. It now leaves the tube and swims away. The animal may swim forward out of the anterior opening of the tube, but if this takes it into the sphere of operation of the stimulus, as will very often be the case, it may force its way backward through the substance of the tube, and thus gain the outside, swimming backward. It then swims away, to form a new tube elsewhere.

Behavior while free.—While thus swimming through the water, after leaving its tube, Stentor takes on the characteristic behavior of the free-swimming infusoria, such as Paramecium. In the open water stimuli are almost lacking for the guidance of the animal, hence its behavior is, paradoxical as this may seem, much less free and varied than is that of the fixed infusorian, or the infusorian creeping on the

bottom; it becomes quite stereotyped. The writer has previously given (Jennings, 1899*b*) an account of the main features in the behavior of *Stentor polymorphus* when swimming in the open water. The behavior of *Stentor roeselii* is essentially similar in character. It rotates to the left on its long axis as it swims, and at the same time it swerves toward one side, — apparently toward the right aboral side. Its path thus becomes a spiral, like that of *Paramecium* (for the significance of this spiral swimming, see Jennings, 1901). When the *Stentor* in its course comes into the region of a stimulating chemical or other stimulating agent, the animal swims backward a little, turns toward the right aboral side, and swims forward again. In all these respects its behavior is essentially like that of *Paramecium*, as described in the second of these studies (Jennings, 1899*a*), so that it will not be described in detail here. At first after leaving the tube the *Stentor* is strongly contracted, of a very short oblong or club-shaped form. Usually as it swims it gradually extends a little, taking a long conical form, but remaining much shorter than the fixed specimen. The animal thus swims rapidly for some time about the vessel in which it is confined. It may be observed that the *Stentor* as it swims secretes over the posterior half of its body a transparent mucus or sticky substance of some sort, since carmine grains or other small particles in the water often cling to the posterior half of the body, or are trailed along some distance behind it, — the mucus evidently pulling out to form threads.

On coming against the surface film or the smooth surface of the glass, the *Stentor* behaves in a peculiar way. The (only partly unfolded) disc is applied to the surface, and the animal creeps or spins rapidly over the surface, often revolving to the left; sometimes not revolving, and always progressing in the direction of the right aboral side or angle of the disc.

On coming in contact with a bit of plant tissue or débris (consisting in the cases observed largely of worm-castings), the *Stentor* usually creeps rapidly over the débris, keeping the ventral surface against it. It thus follows all the irregularities of the surface, as rapidly and neatly as this would be done by one of the *Hypotracha*. This may continue for some time, the animal seeming to explore the object thoroughly; then it may leave the débris and swim about freely again for a period. At times the *Stentor* becomes attached to a piece of débris by the secreted mucus. This is drawn out to form a thread, often several times the length of the *Stentor*; by

means of this thread the Stentor remains suspended in the water, as it were, whirling about on its long axis. It may thus remain partially attached for some time; then the thread is broken by a sharp contraction of the body, and the animal swims away.

Formation of a new tube, and attachment of the foot. — Finally (in three cases that were timed, after fifteen to twenty minutes) the Stentor forms a new tube and attaches itself. This is done as follows. The animal, coming to a small heap of débris, creeps over it with ventral surface against it, as above described, exploring it thoroughly. It becomes evident that mucus is being secreted over the surface of the posterior half of the body, since particles of débris stick to the body, or are trailed behind it. Finally, in a

certain region, often between two masses of débris, the animal begins to move backward and forward, through a distance of only about three fourths of its own length (when contracted). This is kept up for about two minutes, and results in the formation of a short mucus sheath, from the secretion on the outer surface of the Stentor. This process is illustrated in Fig. 6. Now the foot is pressed against the débris at the posterior end of the sheath, where it adheres, — doubtless by the extrusion of pseudopodia, as illustrated in Fig. 2. Now the Stentor extends its body to the full length, — and we find it in the usual attached condition, with the lower half of the body surrounded by a transparent tube of mucus.

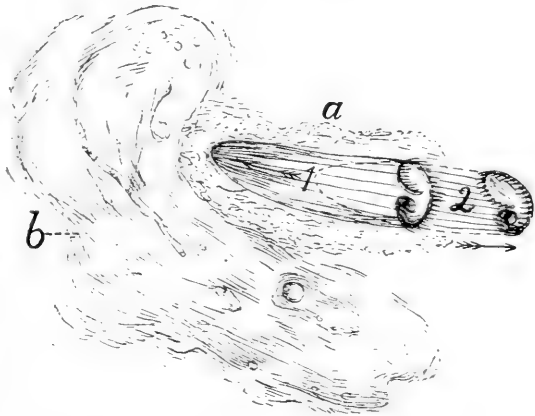

FIGURE 6. — Illustrating the movement of Stentor in forming a new tube. The animal oscillates between the positions 1 and 2, giving off mucus, which forms the tube. *a*, mucus forming the tube; *b*, débris.

Now the foot is pressed against the débris at the posterior end of the sheath, where it adheres, — doubtless by the extrusion of pseudopodia, as illustrated in Fig. 2. Now the Stentor extends its body to the full length, — and we find it in the usual attached condition, with the lower half of the body surrounded by a transparent tube of mucus.

The above account is drawn from observation of the process of settling down and forming a tube in several specimens, and seems to be typical. In one case observed, however, the animal attached itself to the smooth surface of the glass, and this time the process differed. After wandering about for some time, as described above,

the specimen applied its disc to the bottom of the vessel, and revolved for some time on its long axis. Then it ceased revolving, and slowly bent its body till the foot reached the bottom, — the body becoming nearly straight again and tangential to the surface, before this was accomplished (Fig. 7). The foot attached itself to the bottom, then the disc was lifted up, and the body took a position

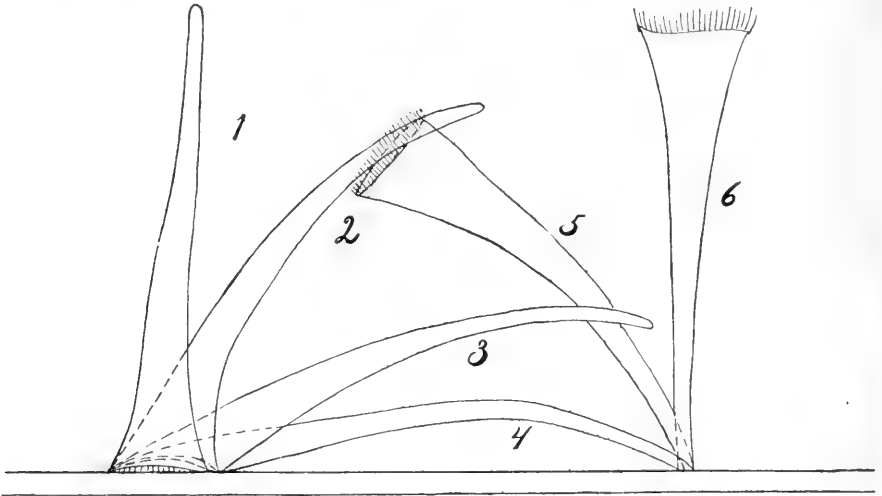

FIGURE 7.— Illustrating the manner in which *Stentor ræselii* attaches itself to a smooth surface. The figures 1-6 represent the successive positions occupied by the Stentor.

perpendicular to the surface. The animal was now attached in the usual way, though the beginning of the tube had not been made. The tube in such a case is formed later, automatically, as it were, by the secretion of mucus on the surface of the body. This becomes compacted and confined to the posterior half of the body by the contractions of the Stentor in responding to stimuli.

Usually, however, the tube is formed before the attachment of the foot, in the manner first described.

Having thus described the typical series of reactions when *Stentor ræselii* is subjected to mechanical stimuli, or to a combination of mechanical and chemical stimuli, we may return and consider the effect of some other stimuli, as well as a number of matters of a different character.

II. Chemical stimuli. — Results essentially the same as those above described are obtained in stimulating *Stentor ræselii* by means of

chemicals. But there are certain points which are of much importance for understanding the method by which such organisms react to chemicals; these will be brought out here.

When a chemical of sufficient strength to act as a stimulus, yet not strong enough to be destructive, is allowed to reach the disc of an attached Stentor, the same series of reactions is given as has been described above, — changing position, reversal of ciliary current, contraction, and final abandonment of the tube. These results were obtained with a weak solution of methylene blue; with the red filtrate from carmine in water, with $\frac{m}{100}$ NaCl, with $\frac{m}{100}$ HCl, and with $\frac{m}{10}$ cane-sugar. In the latter case the effect was evidently due to the osmotic action of the sugar, as will be shown later. Other chemicals were not tried.

After it was found that Stentor would bend directly toward the source of a weak mechanical stimulus, as described above, it was thought possible that an opportunity might be here presented for demonstration of positive or negative chemotropism, — a bending to or from the source of diffusion of a chemical. In other infusoria the writer has been unable to observe a direct turning toward or away from the source of diffusion of any chemical, so that this seemed an opportunity not to be missed. The experiments in this direction developed certain facts which are of much significance for understanding the reactions not only of Stentor, but of other ciliates and flagellates, to chemicals.

The attempt was made to localize very accurately the action of the stimulus, by the use of fine capillary tubes, bringing the chemical near to one side of the body, — so that it might affect one side alone. The Stentor might then be expected to bend toward or away from the side affected. This involves no difficulty in manipulation, but an insuperable difficulty is at once met in the course of the currents produced by the cilia of Stentor. Chemicals placed at one side do not reach the animal at all, as will be seen by an inspection of the course of the currents in Fig. 1. The chemical at *a* is carried past the animal without touching it. This is rendered evident when some colored chemical, such as a solution of methylene blue, is used. If the point of the tube is moved farther toward the front of the Stentor, the solution is involved in the central vortex and is carried directly to the buccal pouch and the mouth (as at *b*, Fig. 1).

Thus unilateral stimulation with a dissolved chemical, elsewhere than at the mouth, is practically impossible. This is true also when

the chemical in solution is advancing with a broad, plane front, as illustrated in Fig. 8. In such a case the solution does not reach the Stentor uniformly distributed, as determined solely by the movements of the ions. On the contrary, as soon as the advancing

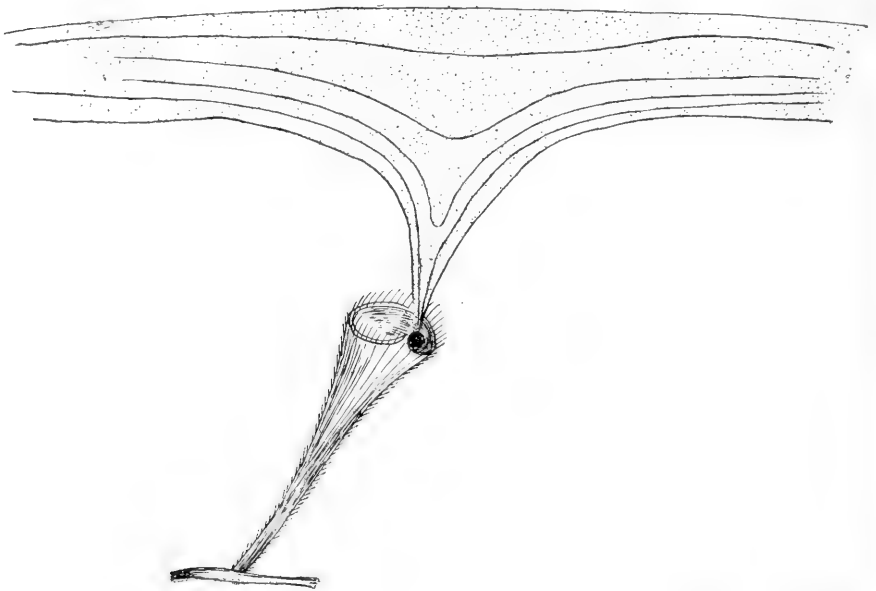

FIGURE 8. — Illustrating the way in which an advancing chemical is drawn out in the alimentary vortex, so as to reach the mouth and disc of Stentor without affecting the remainder of the body.

solution has arrived within a certain distance of the animal, a small cone of the substance is drawn out by the vortex, directly toward the disc of the animal. The point of this cone reaches the buccal pouch and mouth of the Stentor, long before the rest of the chemical has affected the animal. This is very clearly seen when colored chemicals are used.

The result is that the animal always receives its stimulus from a chemical at a certain definite spot, — the mouth or buccal pouch, — while the rest of the chemical remains some distance away. It is obviously impossible for the animal to orient itself in accordance with the natural lines of direction of the diffusing ions. If the organism turns away from the side affected by the chemical, it will of course turn toward the aboral side, — that opposite the mouth, without regard to the original direction of the source of

diffusion of the chemical,—and this is exactly what the animal does.

Parallel conditions exist in the other infusoria. In *Paramecium*, for example, a strong current, corresponding to that which reaches the buccal pouch in *Stentor*, passes along the oral groove to the mouth, the current over the rest of the body being slight in comparison. When a colored solution is used, and a nearly or quite quiet *Paramecium* is found, it may be observed

that an advancing chemical behaves in much the same way as in *Stentor*. A cone of the solution is drawn out opposite the anterior end of the *Paramecium*, and passes down the oral groove to the mouth (Fig. 9). The *Paramecium* receives its stimulus from the chemical, therefore, on the oral side,—and responds, like *Stentor*, by turning toward the aboral side,—usually after swimming backward some distance.

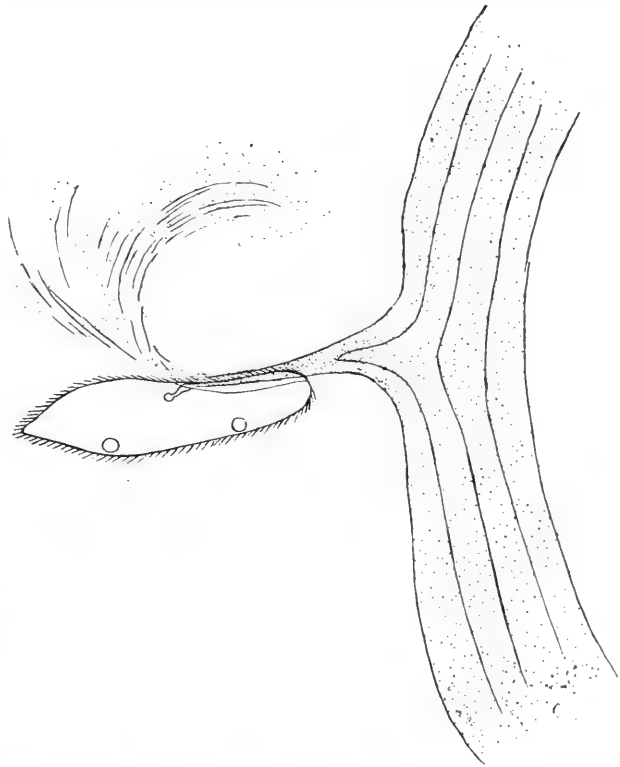

FIGURE 9.—*Paramecium*, showing how an advancing chemical is drawn out by the alimentary vortex, so as to reach the oral side without affecting the rest of the body.

These examples show that we are not justified in expecting the ciliate infusoria in which similar conditions occur to orient themselves to the lines of direction of diffusing ions, as presupposed by some current theories of the reactions of organisms to chemicals. The

organisms are active, and determine for themselves where the stimulus shall first affect them. It is not at all surprising, therefore, that they have not been found thus to orient themselves.

In the Flagellata, owing to the minute size of the body, it is impracticable to determine by experiment whether the conditions for stimulation are or are not the same as those just described for ciliates. But in view of what is known of the movements of the flagella in these organisms, with resultant formation of a vortex having its apex at the mouth,¹ together with the known asymmetry of most flagellates, it can hardly be doubted that the conditions are practically identical with those found in the ciliates. In this group, then, as in the Ciliata, we should not expect to find the organisms orienting themselves to the lines of diffusing ions; they do not permit the ions to follow alone the laws of diffusion, but actively intervene to determine the distribution of the substance in solution. These facts certainly deserve consideration in all work on the reactions of Ciliata and Flagellata to chemicals.

Similar considerations apply to the reactions to other stimuli, in so far as the distribution of the agents concerned depends upon currents in the water. This would be the case, for example, with the reactions to heat and cold, in so far as the stimulation is due to differences in the temperature of the water in different regions. Figures 8 and 9 would serve equally well for the conditions when we have an advancing region of water which is warmer or colder than that about the infusorian. The warmer (or colder) water would be drawn out into a cone and then into a stream, which would affect only the oral side of the animal. It is therefore not surprising that we do not find a direct orientation produced by heat and cold in these animals, the so-called *thermotaxis* being brought about through the mediation of the "motor reaction" (backing and turning toward the aboral side; see Jennings, 1899*a*, page 334).

To radiant heat, to light, and to the electric current, these considerations, of course, do not apply, as the distribution of the stimulating agent in these cases is not affected by currents in the water.

The fact that *Stentor* and *Paramecium* (as well, of course, as many other infusoria) are first stimulated by a chemical on the oral side, and that they respond by turning toward the opposite (aboral) side, seems to indicate that the reaction of these organisms is, primitively

¹ See DELAGE et HEROUARD, 1896, pages 306-312, for a full account of the movements of the flagella and the formation of the alimentary vortex.

at least, truly a localized one. The reason why in reacting they always turn toward the same side would be merely because they are always stimulated on the same side (the opposite one). If this is true, we should expect them, if the stimulus were in some way made to affect the other (aboral) side, to turn toward the oral side, contrary to their usual habit. This may have been the original condition of affairs, and possibly infusoria may exist in which it is realized even at the present time. But that it is not true for most of the infusoria is shown by the reactions to localized mechanical stimuli, as described in the fifth of those studies (Jennings, 1900). It there appears that when ciliates are stimulated on the (unaccustomed) aboral or right side, they respond by turning toward that side, — exactly as when they are stimulated on the opposite side. The unilateral method of reaction has become strongly stamped upon the organisms, being indicated in the unsymmetrical form.

III. Osmotic stimuli. — As in the case of *Paramecium*, sugar seems not to affect *Stentor* through its chemical qualities, but only through its osmotic action, so that opportunity is given for determining the nature of the reaction to changes in the osmotic pressure of the surrounding medium. $\frac{m}{30}$ cane-sugar (about 1 per cent) caused no reaction whatever, though electrolytes of the same osmotic pressure caused a marked reaction, — showing the effect to be due to the chemical qualities, in the latter case. When *Stentor* was flooded with $\frac{m}{10}$ cane-sugar, there was no reaction for seven or eight minutes. By this time the plasmolyzing effect of the solution was very evident; the animals had shrunk considerably. Now there was a sudden strong contraction, the animal remaining contracted several minutes. It then let go its hold and abandoned its tube, forcing its way backward out of the latter.

Even with $\frac{m}{1}$ sugar (about 34 per cent) the response was not immediate. The animal conducted itself normally for about twenty seconds after it was flooded with the solution. By this time shrinkage due to plasmolysis is very evident to the eye; the animal contracts and finally leaves the tube.

B. OTHER FIXED INFUSORIA.

In giving an account of the behavior of some other fixed infusoria, I shall confine myself largely to a comparison with *Stentor ræselii*, bringing out the resemblances and differences, and entering into details only in case of important differences or additional features.

STENTOR CÆRULEUS EHR.

Stentor cæruleus differs from *S. rœselii* in form and in its blue color, and it is usually larger, at least in this region. It does not inhabit a tube, and though frequently attached, it is much more inclined to a free life than is *S. rœselii*, so that it is often found swimming freely in large numbers.

In an attached *Stentor cæruleus* the ciliary currents are essentially like those of *S. rœselii*, and parallel statements may be made for both species as to the ingestion of food particles.

Stentor cæruleus is much more sensitive than *S. rœselii*; otherwise its reactions to mechanical and chemical stimuli are of the same general character, though with several important points of difference.

Stentor cæruleus does not usually bend over toward a solid object touching one side of the disc, as does *S. rœselii*. A large number of experiments on this point gave uniformly negative results.

When the particles of solid substance which are brought against the disc by the water currents are too large, too numerous, or mingled with some chemical, the animal responds, as does *S. rœselii*, by twisting somewhat on its long axis, then bending toward the

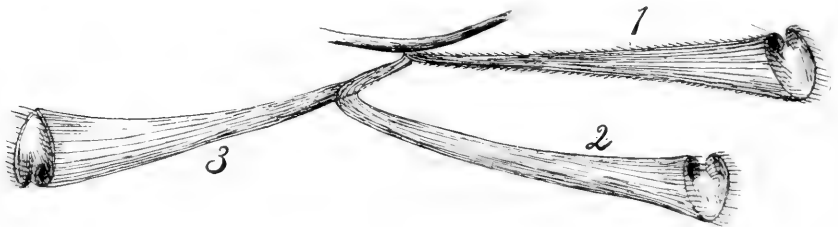

FIGURE 10 — Method by which *Stentor cæruleus* often changes position when stimulated.

The animal occupies first the position 1, then pushes backward into the position 2, with stalk bent, then straightens into position 3.

right aboral side into a new position; by reversing the ciliary current for an instant, and repeating this; by contracting the body; and finally by breaking from the point of attachment and swimming away through the water. In these reactions there is little that is essentially different from the corresponding reactions of *S. rœselii*. A favorite method of changing the position when stimulated is shown in Fig. 10. The specimen backs strongly until the stalk is doubled near the foot. The animal then straightens the body into the position

indicated by the part next to the foot, — thus at an angle of 180° with its previous one.

Stentor cæruleus has recourse to the last step in the series of reactions, — the abandonment of its place of attachment, — much more readily than does *S. rœselii*. In the latter species I was unable to force the animal to leave its place by mechanical shocks alone. Specimens were stimulated by striking the disc with a glass rod, sometimes for an hour continuously, yet the animals did not leave their place. *Stentor cæruleus*, on the other hand, will sometimes break its attachment the first time it is struck with the rod. There is much variation among different specimens on this point; usually it requires many such strokes to produce the result, and all the other reactions in the series are tried first.

After leaving the place of attachment, *Stentor cæruleus* swims through the water in a rather wide spiral, revolving to the left. The body is usually somewhat curved toward the oral side, and apparently as a consequence of this, the animal swerves continually toward the oral side. The tendency to deviation thus caused is corrected by the revolution on the long axis. When the free-swimming *Stentor* receives a mechanical or chemical stimulus, it swims backward a little, then turns toward the right aboral side. The behavior of the free-swimming *Stentor* is thus essentially similar to that of *Paramecium*.

As the *Stentor* swims about well extended, frequently protoplasmic projections may be seen extending from the tip of the foot. These are viscid, so that bits of débris stick to them and are dragged about; sometimes other infusoria, such as *Paramecium*, coming in contact with the foot, are thus dragged along. I have seen two *Stentors* become attached to each other through the accidental coming together of the two posterior tips. If a small glass rod is placed against the tip of the foot, the *Stentor* may frequently be dragged backward by it, owing to adhesion.

Often *Stentor* drags its foot over the bottom or over pieces of plant material. Sometimes it stops in such a position, and in a few seconds the foot is securely fast and the animal is anchored anew.

Stentor cæruleus, unlike *S. rœselii*, reacts to light. The reactions of this and some other ciliates to light will be treated in a separate paper.

VORTICELLA.

Owing to its minute size, *Vorticella* is much less favorable for a study of behavior than is *Stentor*. I was especially desirous of investigating it however in connection with certain statements made in a very interesting paper by Hodge and Aikins (1895). These authors investigated chiefly the question of the rhythmical character of the activities of *Vorticella*. They kept a single *Vorticella* under observation without a moment's intermission for a period of twenty-one hours, besides intermittent study for a number of days. The observations showed "that a *Vorticella* works continuously and shows in its life no period of inactivity or rest, corresponding to periods of rest in higher animals. In other words, a *Vorticella* never sleeps." During five days the cilia were in continuous motion, and food was continuously taken.

Incidentally, Hodge and Aikins made a number of observations on other points. One of these was in regard to the modifiability of reactions in *Vorticella*. An attempt was made to feed the individual under observation upon yeast plants, by introducing some of a pure culture of these organisms into the preparation. "This attempt resulted in an interesting demonstration of the educability of *Vorticellæ*. At first they took this, to them, newly discovered food with great avidity, filling their bodies to distention with food vacuoles of the yeast. In a very few minutes, however, the entire meal was ejected with volcanic energy. Not a single torula was allowed to remain in the body, and for several hours at least—how long the memory lasted was not determined—the individual could not be induced to repeat the experiment."

It is much to be regretted that further details are not given in regard to this interesting experiment. We are not told whether the *Vorticella* continued its normal behavior and took in other food during the time in which it refused the yeast. It might be that the animal was merely injured by the food, and took nothing more into its body until it had recovered. We are not informed in what way *Vorticella* refused later to take the yeast,—whether by contracting, by reversing the ciliary current and turning the yeast out of the pouch, or in some other way. Yet upon these points depends largely the interpretation that shall be given to the observation.

I have endeavored, and as I judge with some success, to reproduce

the essential features of this experiment. I have not succeeded with the yeast, for the *Vorticellæ* at once contracted, in my experiments, when the yeast culture was introduced. But a similar result may be obtained in a very simple way. In the case of the yeast culture we have a fluid containing various chemicals in solution, and holding in suspension many small bodies. These conditions may be imitated by grinding up ordinary carmine in water. A little of the carmine goes into solution, as may be shown by filtering the water, which will be found to have become red. This red solution was found to act as a slight chemical stimulus, on both *Vorticella* and *Stentor*.

When some of this carmine and water is added to the water about the *Vorticella*, the course of events is about as follows. For a short time—ten to fifteen seconds, or sometimes more—the current caused by the cilia is kept up in the usual manner, and many of the carmine grains are taken into the internal protoplasm, forming red food vacuoles. Then there is a sudden contraction of the stalk, the ciliary disc closing at the same time. This is repeated several times, the ciliary disc however remaining closed while the stalk partly extends and retracts. Then usually the *Vorticella* extends in a new direction. If the carmine continues to be present, the contractions are repeated for ten or fifteen minutes or more. Then the stalk may remain extended, but the ciliary disc remains closed, so that no more carmine is ingested. This condition lasts as long as the carmine is present in large quantities.

Thus in this case, as in that described by Hodge and Aikins, *Vorticella* at first ingests a certain substance which it later refuses. This is also true of *Stentor*, as will be seen by consulting the account above given of the behavior of *Stentor* when much carmine is added to the water containing it. In no case was *Vorticella* observed to throw out the granules which it had already ingested, as described by Hodge and Aikins, but this is perhaps an unessential difference, as of course this has nothing to do with the "educability" of the animal.

In this experiment, I am convinced that the refusal of the *Vorticella* to continue to take the substance is due to a too great stimulation, either in the quantity of material, or, more probably, in the strength of the chemical action of the substance, rather than to any precise choice in the kind of substance ingested. There is evidence for this in the following fact. If the quantity of carmine in the water is greatly decreased, so that only scattered grains are left, the

Vorticella or Stentor no longer reacts to these, and they are ingested, gradually forming red vacuoles in the endosarc. Whether this would have been true in the experiment of Hodge and Aikins the data they have given do not enable us to judge.

In regard to a point closely connected with the above, the attitude of Hodge and Aikins must, I think, be considered uncritical. This relates to the sorting of food by the cilia. Among the "psycho-reflexes" of Vorticella, Hodge and Aikins include "3. Sorting of particles by the sensory cilia; the driving of food toward the mouth, and the driving away of waste particles." Further "When a particle is touched by the cilia an act of choice is apparent, and in accordance with this choice the particle is carried toward the mouth or whirled away." "Particles scarcely visible under the microscope are sorted with the greatest apparent precision." "A prime condition of the creature's life must be ability to distinguish food from that which is not food."

Beyond these general statements quoted no details are given. The authors report no critical observations or experiments as to what substances are ingested, what rejected in this sorting process. It is well known that investigators that have made such experiments have concluded that no such sorting takes place. Thus Verworn (1889, page 150) found that Vorticella ingests carmine grains, indigo, and chalk crystals, and I have myself observed the same facts. These are substances which cannot serve as food, so that Hodge and Aikins are certainly mistaken in their belief that "a prime condition of the creature's life must be the ability to distinguish food from that which is not food." Such organisms as Vorticella and Paramecium grow and multiply in situations such that the substance brought to the mouth by the currents consists largely of food, without any sorting; when this condition disappears, the organisms quickly die. The ingestion at the same time of some substances which do not serve as food is not particularly injurious to the organism, as these are simply passed out of the body with the waste matter at the time of defecation.

The impression that a sorting and selection takes place among the particles brought to the mouth probably arose from the following observations. Vorticella, as well as Stentor, brings to the buccal pouch in its alimentary vortex many more particles than are taken into the body. When the water contains many particles a continuous stream of these may be seen passing out of the buccal pouch. From

this it is most natural to conclude that the material has been sorted, the valuable particles ingested, and the particles which are not nutritious turned away. But experiment does not support this conclusion. Thus, when all of the particles are of the same sort, either nutritious or not, part are taken into the interior, while a large portion are turned away. This is true on the one hand of grains of sepia, which are quite insoluble and non-nutritious; it is true, on the other hand, also, when many nutritious unicellular algæ are brought to the mouth. In the latter case, as in the former, many more of the particles are turned away than are taken in. The explanation of these facts is evident when one considers the mechanism of the alimentary vortex, as has already been pointed out by Verworn (1889). A large, strong current of water is carried toward the disc of the Vorticella. Inevitably, much of the water misses the disc completely, and the food particles which it contains never touch the animal. Another portion of the water strikes the disc, but not all of this can enter the relatively small buccal pouch, so that many of the food particles which strike the disc are whirled away again into the water. In the same way a rapid whirlpool is formed in the buccal pouch, but only a small part of the water in this can reach the relatively minute mouth, and it is only from this small part that the food can be taken. Thus there is a continual stream of particles passing out of the pouch, that have never come in contact with the mouth.

These mechanical considerations explain also the following noticeable fact. When the water contains but few particles, whether nutritious or not, only a few are ingested, while a large proportion of them are whirled out of the pouch and away. When the number of particles in the water is great a large number are ingested in a short time, without regard to whether they are or are not useful as food. The number of particles ingested depends primarily upon the number which reach the mouth opening, and this is only a small proportion of those involved in the general ciliary vortex.

This question of the sorting power of the cilia is, I take it, merely one of fact, and not one involving any important principle. What we know of choice in the Rhizopoda, and the parallel phenomena in inorganic fluids, to which reference has already been made, shows that there would be nothing new in principle if the cilia of Vorticella exercised choice in the same way. But the facts seem to indicate that they do not. Choice in these animals seems to be shown only

in such phenomena as the reversal of the ciliary motion, bending over into a new position, and contraction, — these being, of course, different methods, somewhat crude perhaps, of rejecting certain things, and thus of exercising choice.

C. BECOMING ACCUSTOMED TO STIMULI.

Are the reactions of such organisms invariable, or does the reaction to a given stimulus depend on previous subjection to the same or different stimuli? The problem of the modifiability of the reactions of these lowest organisms is one of great interest, but one on which there exists but little precise experimental data. Scattered allusions to changeability in the reactions of the lower organisms are to be found in the literature, especially with relation to what might be called acclimatization to stimuli. Massart (1901, page 8) states that it is often to be observed that organisms which have reacted several times in succession, at short intervals, to a given stimulus, lose, little by little, the power of responding to this stimulus, but that this is doubtless to be attributed to fatigue. Loeb (1900, page 228) has discussed such a case in the reactions of worms to a shadow, as described by Nagel, and has attributed the lack of reaction when the stimulus is repeated to "a simple after effect of the stimulus, a case that we often meet with in the physiology of both animals and plants." Davenport (1897, page 108) gives an example drawn from the behavior of one of the organisms at present under consideration. "When an organism has been stimulated by contact for some time, it at last becomes changed, so that it no longer responds as it did at first. Thus, Dr. W. E. Castle informs me that he has seen a colony of *Stentors*, in an aquarium, being constantly struck by *Tubifex* waving back and forth, yet the *Stentors* did not contract as they usually do when struck."

Such contractions in the fixed infusoria furnish a most favorable opportunity for an investigation of this matter, and I therefore undertook to obtain some precise experimental data upon the subject. Experiments were made upon *Stentor rœselii*, *S. cæruleus*, *Vorticella*, *Epistylis*, and *Carchesium*.

First, the conditions described in the observation by Castle, above cited, were imitated, by striking the extended infusorian with a fine glass rod or hair, under the Braus-Drüner stereoscopic binocular. The chief difficulty in these experiments is to make the successive

strokes approximately equal in force. This can be done but very imperfectly; nevertheless the results are clear.

The first stroke, whether light or heavy, given to an individual that has been undisturbed for an hour or more, almost invariably results in causing a quick contraction. This is true for all the organisms worked with. The animals remain contracted a minute or less, then slowly extend. At the instant when extension was complete, another stroke was given. This, and several successive strokes usually caused the same reaction as the first one. After ten or a dozen reactions, however, the organisms usually did not contract as soon as touched; the stroke had to be repeated one or more times before reaction was caused. A typical series for *Stentor cæruleus* is given in the following. The figures represent the number of strokes in each case before contraction took place, — a contraction occurring thus at each dash:

1-1-1-1-1-1-1-2-2-1-2-1-2-4-1-1-1-1-1-2-6-10-1-2-9-13-3-14-7-3-2-3-3-9-18- (at this point the *Stentor* pulled its foot loose and abandoned its place).

As is evident from the above, there is much irregularity in the number of strokes required to cause contraction. This is due, partly at least, to the practical impossibility of giving successive strokes of equal force. But the *Stentor* responded at first to the lightest possible touches, while later it required a considerable number of smart strokes to cause contraction.

Sometimes there is a ready response only to the first touch, as in the following series (*Stentor cæruleus*):

1-22-25- (breaks away).

1-1-40- (breaks away).

In these cases the organism does not remain entirely oblivious to the blows, but after it has ceased to react by contracting it continually changes its position, by twisting, then turning toward the aboral side, as if trying to escape from the blows. The final reaction, in *Stentor cæruleus*, is to break away from its attachment and swim away.

In *Stentor rœselii*, *Vorticella*, *Epistylis*, and *Carchesium*, similar results were obtained, save that these organisms never broke away from the attachment as a result of such mechanical stimuli. A typical series for an individual of *Epistylis flavicans*, var. *procumbens*, was as follows:

1-1-1-1-1-1-1-2-33-25-7-13-36-20-14-13-13-33-9-30-3-31-226.

In another series the results were as follows :

1-22-10-3-3-1-1-22-59-125- (continuous blows for 1 min.)
 - ($\frac{3}{4}$ min.) - ($1\frac{1}{2}$ min.) - ($4\frac{1}{2}$ min.).

Some series show greater irregularity than the above. As in the case of *Stentor*, during the latter part of the experiment the *Epistylis* continually changed its position, as if trying to escape from the blows.

A typical series for *Stentor roeselii*, obtained in this case by jarring with the rod the leaf to which the *Stentor* was attached, is as follows :

1-1-1-1-1-1-1-1-1-1-1-1-1-3-1-5-1-1-3-1-3-3-48-40
 -2-250-36-36-154

The results for *Vorticella* are similar. In a typical case the animal contracted after each of the first nine strokes. Then the contractions became less sudden; two or more strokes were required to produce them. After about twenty contractions the *Vorticellæ* could be tapped almost indefinitely without causing further contraction.

Carchesium polypinum is a tree-like colony composed of many *Vorticella*-like individuals, attached to the branches of a common stalk. The stalk muscles of the individuals are not continuous throughout the colony, so that it is possible, though not usual, for each individual to contract separately.

Carchesium shows very markedly the acclimatization to a stimulus. Observing first the reactions of a single individual that is repeatedly stimulated, it is found that its stalk contracts strongly at every stroke. But after about five minutes there is a marked change in the readiness to respond. Several strokes are required to cause contraction. Still later the stalk ceases to contract when the individual is struck, though for a time the peristome is folded inward and the ciliary motion ceases after every stroke, without contraction of the stalk. When thus continuously stimulated, usually the stalk contracts at intervals of two or three minutes, — though the strokes come as often as one per second.

The effect of the stimulation of a single individual on the colony as a whole is interesting. If a single individual in an otherwise undisturbed colony is struck with the glass rod, usually the entire colony contracts at once, forming an almost solid ball. Apparently the sharp contraction of a single individual, by jarring the colony, acts as a stimulus to cause the contraction of all the other individuals. If the stimulus is repeated (on the same individual) as soon as the colony has become extended, usually only about half of the colony contracts. The third time only the large branch reacts to which the

individual stimulated belongs. After this the number of neighboring individuals contracting when the single individual reacts is variable, ranging usually from half a dozen to thirty or forty. When the condition is reached where the individual, continually stimulated, reacts but once in two or three minutes, nearly the entire colony contracts with it.

What is the explanation of this failure to react to a stimulus to which the organism at first reacts readily? Three possibilities present themselves. (1) The lack of reaction might be due to fatigue of the contracting apparatus (corresponding to muscular fatigue in the higher animals). (2) It might be due to fatigue of the sensory function, so that the organism no longer perceives the stimulus (corresponding to fatigue of the sense organs in higher animals). (3) It is possible that the phenomenon cannot be explained as fatigue, so that all we can do is to formulate the facts, calling it an "after-effect," or other name which carries no implication as to its nature. We should perhaps have parallel phenomena for this also in the case of a higher organism, which reacts to a sudden, unexpected shock, but does not react a second time, though the stimulus is repeated, and is perceived by the organism.

Some farther data needed for forming an opinion as to which of these possibilities represents the truth may be obtained by varying the experiments. Striking the animal with the glass hair is a rather brutal method of experimentation; reactions may be produced with much slighter stimuli, and the results are much clearer.

For this purpose weak currents of water may be employed. This was done as follows: A tube 28 cm. long and of 5 mm. bore was drawn to a very fine capillary point and then filled with water. When the capillary end is below, there is of course a slight current of water from the tip, due to the pressure of the water in the tube above. Now the tip was brought close to an individual of *Epistylis*, so that the current flowed against the latter. At once the animal contracts. If the current is continued the *Epistylis* soon unfolds, and continues open and active in spite of the current. If now the tube is removed, so that the current no longer acts, then in a few seconds is restored, the animal does not react. Moving the tip of the tube over to a fresh specimen, this reacts at once. Moving it back to the first specimen, this does not contract. With a large colony of *Epistylis*, it was possible thus to test many specimens;

invariably the animal reacted to the stimulus of the current the first time, but later did not. In a very few cases a certain individual would react also to the second or third or even fourth stimulus, but soon ceased, and in a large majority of cases the animals reacted only the first time.

In *Stentor roeselii* the same results were obtained. The animals invariably reacted to the first stimulus of the current, but none of the numerous individuals studied reacted to a repetition. *Stentor cæruleus* behaves in a similar manner. In this species the individuals often respond only once by contraction, even to the stimulus of a stroke with the glass rod; after the first contraction they react only by bending over into a new position.

A large colony of *Carchesium polypinum* was situated just beneath the surface of the water. Touching the surface film with a needle, the colony at once contracted strongly. It was allowed to expand, and the surface film touched as before. There was no contraction. Repeated touching of the film caused no reaction, except the first time. Jarring the branch to which a colony was attached gave rise to a parallel series of phenomena.

From these results it is clear that the lack of reaction cannot be due to fatigue of the contractile elements. It is possible, as I have demonstrated by experiment, to keep *Stentor* continuously contracting for an hour at a time. Yet the animal responds only once to a weak stimulus; it cannot be supposed to have been so fatigued by this single contraction that it cannot contract farther.

It seems evident also that the failure to react after the first time cannot be due to fatigue of the sensory or perceptive power. It can hardly be supposed that a single stimulus would result in such fatigue that further stimuli are no longer perceived. Moreover this supposition is directly negated by the fact that in many cases there is other proof that the organism does continue to perceive the stimulus. Thus, with *Stentor cæruleus*, as described above, at the first stimulus by tapping with the glass rod the animal contracts suddenly and strongly. After this it no longer contracts, but the fact that it perceives the stimulus is shown by its bending far over first in one direction, then in another, as the stimuli are continued, as if trying to avoid the blows. The impression made on the observer is very much as if the organism were at first trying to escape a danger, and later merely trying to avoid an annoyance. Similar phenomena may be observed with *Epistylis* and *Vorticella*.

Thus the third alternative seems the only conclusion to which we can reasonably come, in view of the facts. The organism becomes changed after stimulation, in such a way that it no longer reacts to a stimulus to which it at first reacted. There is a difference in the physiological condition of the organism before and after the stimulus. One can hardly avoid comparing these phenomena with the fact that in a higher organism a sudden unexpected touch or other stimulus will cause a reaction or "jump," when the same stimulus, not unexpected, causes no reaction whatever. It seems not improbable that the phenomena are similar in fundamental character in the two cases.

This resemblance is increased by certain further considerations. It is only when the stimuli are non-injurious that the unicellular organism ceases to respond upon repetition of the stimulus. If the stimulus is very powerful or injurious, the reaction is continued indefinitely. I attempted to accustom *Stentor* to the stimulus from a very minute quantity of $\frac{m}{150}$ NaCl, brought close to it with a minute capillary tube. Though the stimulus was repeated at very short intervals for an hour steadily, the *Stentor* reacted in every case; there was no indication of becoming accustomed to the stimulus.

The changes to be observed in the character of the reactions to a given stimulus when repeated show the same relation to the nature of the stimulus. As described in the first part of this paper, when the stimulus continues, and is powerful so that the reactions also continue, the reaction does not remain the same, but there is a series of different reactions. This series is a progression from less effective to more effective reactions, culminating in the animal's abandoning its place. On the other hand, as we have seen above, the reaction is sometimes changed also in the case of a weak stimulus, as when *Stentor* is tapped with the glass rod. But in this case the progression is in the opposite direction, — from a strong, effective reaction (contraction) to a weak one (bending over to one side.) The course of the reaction series, whether from less intense to more intense, or vice versa, depends upon the nature of the effect of the stimulus on the organism.

D. ANALYSIS OF THE OBSERVATIONS, WITH DISCUSSION OF THEIR BEARINGS ON CERTAIN GENERAL PROBLEMS.

The examination of the behavior of *Stentor* shows a striking contrast with the known behavior of *Paramecium*, in the much greater

complexity and adaptability of the former. In *Paramecium* the behavior seems made up of a few simple reflexes, with little variation or adaptability. In *Stentor*, on the contrary, this is far from being the case. This difference is due, I believe, to the different method of life. *Paramecium* is typically a free-swimming organism. As I have pointed out elsewhere,¹ in the open water there are few stimuli to guide an organism, the conditions being nearly uniform in all directions. Especially is this true in the case of an organism which, like *Paramecium*, is not sensitive to light. The result is the development of a few simple, almost machine-like devices for governing locomotion. Such a device is the spiral course, preventing the organism from aimless wandering in circles; such a device is the invariable turning toward a certain structurally marked side when stimulated, which is so striking in *Paramecium*. On the other hand, an organism on the bottom is continually receiving stimuli of varied character, and it develops in consonance therewith a varied behavior. This difference between the behavior of free-swimming organisms and that of those which live on the bottom is very great, and its importance is not usually recognized. Even in the same individual the behavior becomes of a very different type on changing from one of these situations to the other. *Stentor* when free-swimming has the same simple behavior shown in *Paramecium*, while in *Paramecium* and other infusoria the behavior is greatly modified by contact with surfaces.²

Proceeding to an analysis of the behavior of *Stentor*, it is evident in the first place that the same external stimulus is not always answered by the same reaction, but that the reaction given depends largely on the history of the individual (and thus upon its present physiological condition). Thus we find the following to be true:—

1. After reacting to a given stimulus one or more times, if the stimulus is not a harmful one, the organism may cease to react, though the stimulus is repeated without change.

2. After reacting to a given stimulus the first time by a very pronounced reaction (contraction), the organism may later react, if the stimulus turns out to be a non-injurious one, by a very slight reaction, as by bending over to one side.

3. In the case of a stimulus which must in the long run be classed

¹ See JENNINGS, 1901.

² On some of the modifications in the behavior of organisms when in contact with surfaces, see especially PÜTTER, 1900, and JENNINGS, 1897, pages 305-312. There is opportunity for further investigation in this matter.

as harmful, as when a dense cloud of carmine is added to the water, a series of reactions is to be observed, becoming of more and more pronounced character, until by one of them the organism rids itself of the stimulus. The course of events in such a case is usually as follows: —

a. No reaction at first; the organism continues its normal activities for a short time.

b. Then a slight reaction by turning into a new position, a seeming attempt to keep up the normal activities and yet get rid of the stimulus.

c. If this is unsuccessful, we have next a slight interruption of the normal activities, in a momentary reversal of the ciliary current, — tending to get rid of the stimulus.

d. If the stimulus still persists, the animal breaks off its normal activity completely, by contracting strongly, — devoting itself entirely, as it were, to getting rid of the stimulus, — though retaining the possibility of resuming its normal activity in the same place at any moment.

This reaction is repeated many times, the organism extending and immediately re-contracting as soon as the stimulus is perceived. In this case it is interesting to note that the organism now responds at once to a stimulus (by contracting) to which it at first did not respond, or to which it responded only by a reaction of different, less decided character. In paragraph 1 above we have the opposite case, where the organism ceases to respond to a stimulus to which it at first did respond.

e. Finally, if all these reactions remain ineffective in getting rid of the stimulus, the animal not only gives up completely its usual activities, but puts in operation another set, having a much more radical effect in separating the animal from the stimulating agent. It abandons its tube, swims away, and forms another one in a situation where the stimulus does not act upon it.

It is to be noted that this series of reactions is not of such a character that each step necessarily produces the next one; on the contrary, the bringing into operation of any step depends upon the ineffectiveness of the preceding ones in getting rid of the stimulus. The series may cease at any point, as soon as the stimulus disappears.

Further, the succeeding reactions are not mere accentuations of the preceding ones, but differ completely in character from them, being based upon different methods of getting rid of the stimulus.

Throughout the whole of the series of reactions the stimulating agent remains without change. The differences in reaction are due then to changes in the organism, — to such changes as in a higher organism might be called changes in the "state of mind." Here we may perhaps call them changes in the "state of protoplasm," though without implying that the two expressions are fundamentally different in signification.

It is clear that it is impossible to bring such behavior under the rubric "tropisms" or "taxis," or to present it as purely reflex in character; we must at the very least take into consideration physiological states of the protoplasm, as well as reflex factors. To gain a really satisfactory insight into the behavior, it is necessary to go farther than this, and to take into consideration the ends to be attained by the different reactions and changes in reaction, — though whether this necessity has its foundation only in the human way of looking at things, or is really inherent in the behavior of *Stentor*, is a question on which there may be difference of opinion. In any case it will be well to analyze the behavior a little farther from this point of view. So far as outward appearances go, *Stentor* seems to react, like a higher organism, not merely to a stimulus now present; but to what is to come, — to the results of the action, as well as to the present conditions. The changes in the reactions, as the stimulus continues, seem to be directed toward the end of getting rid of the stimulus, — a different method being tried when one method fails. In the method of formation of a new tube, the same apparent reference to an end to be attained is forced upon the attention; there is no visible stimulus for the backward and forward movement of the *Stentor*, which results in the formation of a new tube; no reason that can be seen for this movement, except that it does form a tube.

We have thus in this unicellular organism the outward signs of action directed toward the accomplishment of certain ends, and thus, in so far, of intelligent action. There are, of course, a number of different ways of interpreting such phenomena. To say that the reaction is really directed toward the accomplishment of an end, is to say that the animal reacts, not merely to a present external stimulus, but also to a non-present result of its reaction. This is only possible if the organism has already, at some previous time, experienced this result, so that the latter has left a trace; has modified the organism, — changed its physiological condition. The organism when stimulated reacts in accordance with, or in conse-

quence of, this modification, as well as in response to the external stimulus; the result is action directed toward an end.

Thus in action directed toward the accomplishment of an end there is an element in the organism, — a "trace" or "modification," corresponding to the result to be attained, and due to previous experience of this result. But a different view is often taken of action which appears outwardly to be directed toward the accomplishment of a certain result. In many such cases it is maintained that the organism really has no trace or modification corresponding to the result attained. In the case of *Stentor*, it would be held that the organism has become a sort of mechanism which gives a definite series of responses, when energy of such and such a character acts upon it under such and such conditions, for such and such a period of time. The result follows just as a precipitate is produced in a chemical reaction. The difficult problem according to this view is how reactions happen to be produced that are adapted to the accomplishment of certain ends. This is explained (usually) by natural selection.

In many of the instincts of higher organisms, such a view as that last set forth seems forced upon us by the fact that the organism has had no opportunity to get impressed upon it any trace or modification corresponding to the result to be produced. The animal responds before it has ever experienced the result. Cases of this sort will occur to every one.

In *Stentor*, however, this difficulty perhaps hardly exists, since it is not possible to separate sharply the given *Stentor* from its ancestors that may have experienced the results of any given reaction. Since each *Stentor* arises by simple division of a previous *Stentor*, there is here no special difficulty in the inheritance of acquired characters. If a given *Stentor* has become modified by certain experiences, there is no evident reason why the two *Stentors* derived from it by division should not retain this modification. Hence we have no absolute ground for maintaining on this basis that in *Stentor* the apparent reaction with reference to the result to be attained is not really a reaction with such reference. In other respects, we seem to have the same problem in attempting to explain the behavior of *Stentor* that we have in the instincts of higher animals.

It may not be out of place, finally, to indicate the bearing of the behavior of *Stentor* on the problem of consciousness in the lower

organisms, a matter which has been much discussed of late. I do not see that there can be any objective criterion of consciousness, hence this question in strictness does not fall within the field of an investigation directed to the end of determining what observation and experiment can tell us of the behavior of an organism. But it may be of interest to point out the relation of the phenomena described to certain questions that have been raised. In former papers (Jennings, 1899*a*, page 339; 1899*b*, page 13), I expressed the opinion that in *Paramecium* the behavior was comparable to that of an isolated muscle, and that "we are not compelled to assume consciousness or intelligence in any form to explain its activities." This statement is, of course, well within the facts, as far as objective investigation can give them to us, yet it is perhaps of little significance, since it could probably be made for any organism, outside of the self. The behavior of *Paramecium* is of a character to emphasize strongly the possible machine-like character of the activities of the lower organisms. In *Stentor* we have a very different case, showing that the behavior of *Paramecium* cannot be considered a type for that of all infusoria. *Paramecium* has become adapted in its behavior to a very simple set of conditions, and its behavior is of corresponding simplicity. In the behavior of *Stentor*, we find all the outward indications of action directed toward the accomplishment of certain ends. We have then the same ground for attributing consciousness to *Stentor* as to higher animals which show behavior of a similar character, — no more, no less.

In a recent paper Minot (1902) has expressed the opinion that "the function of consciousness is to dislocate in time the reactions from the sensations," — to inhibit the direct reactions at certain times; to cause reactions at certain times to stimuli that have occurred previously. "This disarrangement . . . seems to me the most fundamental and essential characteristic of consciousness that we know, —" "— and so far as we know, it belongs exclusively to consciousness."

Judged by this criterion (substituting "stimulus" for "sensation" as used by Minot) we should clearly have to attribute consciousness to *Stentor*. As shown above, this organism at certain times inhibits the reactions to stimuli, to which at other times it reacts strongly. Moreover, the nature of its reactions to a given stimulus depends upon stimuli previously received, and this I think is all we can mean when we say that an animal reacts at a certain time to a stimulus previously received. I confess that Dr. Minot's criterion seems to me by no

means an absolute one; and that unconscious mechanisms could be constructed, and indeed do exist, in which there is a dislocation in time between the action of an outer agent upon the machine and the reaction of the machine, similar to that which we find in organisms. It is nevertheless interesting to find the behavior of a unicellular organism falling within the category that would be considered conscious by Minot.

If we consider now the criterion held by Loeb and Bethe, — that consciousness depends upon associative memory, upon the power of learning, — it is perhaps not so easy to decide where *Stentor* stands. The changes in reaction when the stimulus is long continued; first no reaction, then bending into new position, then reversal of the ciliary motion, then contraction many times repeated, and final leaving of the tube, could perhaps be considered cumulative effects of the stimulus, and hence as not giving evidence of associative memory. But this of course leaves quite out of consideration the fact these different reactions are all adapted, by different methods, to getting rid of the stimulus, and it is exactly this adaptation to an end that furnishes the real problem. How does the organism happen to give these particular reactions, thus adapted to the accomplishment of an end? If it gives these particular reactions as a result of experience, it has learned, hence, on the hypothesis we are considering, it has consciousness. If it has not learned to give these purposive reactions, the only alternative hypothesis as to how this has come about is, so far as I am aware, through the action of natural selection upon chance movements.

All together, it must be clearly recognized, I think, that objective study can give us nothing final on the problem of whether consciousness does or does not exist in the lower organisms. We can have indeed no absolute proof of the existence of consciousness outside of ourselves. Whether one holds that *Stentor* and *Paramecium* have or have not consciousness will depend chiefly upon his general system of philosophy, which is of course not mainly determined by observation and experiment.

E. SUMMARY.

The foregoing paper comprises a study of the behavior of *Stentor ræselii*, *Stentor cæruleus*, and *Vorticella*.

Taking *Stentor ræselii* as the type, the following are the most important points brought out:

I. In the unstimulated Stentor the ciliary motion causes a vortex whirling to the left and descending to a point on the left oral side. Only a small part of the water or suspended material in the vortex reaches the mouth. The unstimulated Stentor does not contract.

II: Under the influence of slight mechanical stimuli, as when carmine grains or other small objects are carried to the disc by the vortex, the behavior is as follows:—

A. For a time the normal behavior may be continued, some of the particles being ingested.

B. In some cases the Stentor may bend toward an object touching one side of the disc ("positive thigmotaxis").

C. With repeated weak stimuli, the Stentor may react the first time by contraction; then cease to react farther, though the stimulus is continued. Or the animal may react the first time by contraction; later by merely turning to one side, as described in paragraph I, below.

D. When the objects striking the Stentor are very numerous or large or are combined with a chemical stimulus, or are otherwise unfavorable, there is a series of reactions, as follows:—

1. The Stentor first bends into a new position, by twisting on the long axis, then bending toward its aboral side. It may thus rid itself of the stimulus; if not, this reaction is usually repeated a number of times.

2. If the reaction described above does not rid the animal of the stimulus, it next reverses the ciliary current for an instant. This reaction may be repeated a number of times.

3. If the stimulus still continues, the animal next contracts into its tube. This reaction is repeated many times, if the stimulus continues, and usually the period during which the animal remains contracted becomes longer.

4. Finally, if the stimulus continues, the animal lets go its hold and abandons its tube. It swims away through the water, its behavior while free being similar to that of Paramecium. After a time it forms a new tube, by a peculiar process, in another place, where it is not affected by the stimulus, and remains there.

III. Under chemical stimuli (1) the reactions are essentially the same as above described for mechanical stimuli, the series 1-4 described above taking place in a similar manner. (2) The distribution of a diffusing chemical approaching the Stentor is determined by the ciliary vortex of the Stentor. The result is that the chemical

arrives at the mouth and oral surface of the Stentor before it touches any other part of the body; the latter may remain for a long time quite unaffected. Hence the conditions necessary for the orientation of the body in lines of diffusing ions are not present, and such orientation cannot occur. This is true also for other ciliate infusoria; probably also for flagellates.

Similar considerations apply also to the reactions to temperature variations in the water.

IV. To osmotic stimuli Stentor responds only after plasmolysis is far advanced.

V. In Stentor *cæruleus* the behavior is essentially similar to that of *S. ræselii*, — the same series of reactions being given to continued stimuli. The following differences are to be noted: —

1. Stentor *cæruleus* does not bend toward a weak mechanical stimulus at one side of the disc, as does *S. ræselii*.

2. Stentor *cæruleus* has no tube and abandons its place of attachment much more readily than does *S. ræselii*.

VI. In general the reactions of *Vorticella* are similar to those of Stentor, though it was not observed to abandon its place as a response to stimuli.

VII. Stentor, *Vorticella*, *Epistylis*, and *Carchesium* were found to become accustomed to repeated mechanical stimuli, so that they cease to respond by contracting when the stimulus is repeated. This is not due to fatigue, since they frequently respond only to the first stimulus. It is likewise not due to lack of perception of the stimulus, since after ceasing to contract they often give other evidence that the stimulus is perceived.

VIII. On the whole the behavior of Stentor is complicated, as compared with that of *Paramecium*, and shows considerable power of adaptation. Whether the animal reacts to a given stimulus or not, and how it reacts, depends upon previous subjection to this stimulus, and upon the previous method of reacting to it. If a stimulus continues, the animal gives a series of reactions which are not invariable in order or length of continuance; each reaction of this series is adapted, by a different method from the others, to getting rid of the stimulus. These reactions, together with the method of forming a new tube, have the appearance of being directed toward the accomplishment of definite ends.

LITERATURE CITED.

- DAVENPORT, C. B.
1897. Experimental morphology, i.
- DELAGE et HEROUARD.
1896. Traité de zoologie concrète, i.
- HODGE, C. F., and AIKINS, H. A.
1895. American journal of psychology, vi, pp. 524-533.
- JENNINGS, H. S.
1897. Journal of physiology, xxi, pp. 258-322.
1899*a*. This journal, ii, pp. 311-341.
1899*b*. American naturalist, xxxiii, pp. 373-389.
1900. This journal, iii, pp. 229-260.
1901. American naturalist, xxxv, pp. 369-378.
1902. Journal of applied microscopy, Jan., pp. 1597-1602.
- JOHNSON, H. P.
1893. Journal of morphology, viii, pp. 467-556.
- LOEB, J.
1900. Comparative physiology of the brain and comparative psychology.
- MASSART, J.
1901. Annales de l'Institut Pasteur, Aug. 25.
- MINOT, CHARLES S.
1902. Science, xvi, no. 392, pp. 1-12.
- PÜTTER, AUG.
1900. Archiv für Physiologie, supplement-Band, pp. 243-302.
- RHUMBLER, L.
1898. Archiv für Entwicklungsmechanik, vii, pp. 103-350.
- VERWORN, M.
1889. Psycho-physiologische Protistenstudien, 218 pp.

THE ACTION OF ALCOHOL ON MUSCLE.

BY FREDERIC S. LEE AND WILLIAM SALANT.

[From the Physiological Laboratory of Columbia University, at the College of Physicians and Surgeons, New York.]

DURING recent years the subject of the physiological action of alcohol has received in the laboratories much attention, but experimenters have strangely neglected the action of this drug on muscle.

Twenty years ago Kobert,¹ experimenting on frog's muscle, maintained that alcohol, when given in large doses, greatly diminished contraction, but that this did not occur with small or medium quantities. Later Lombard, Frey, Destrée, Kraepelin and his pupils, and Scheffer, obtained with the ergograph interesting and valuable results with the drug in the human being; but such an organism is too complex to afford a solution of the problem at hand. It was only two years ago that the correct method, that of isolating the muscle tissue, was again employed, and in this manner Scheffer² discovered that the frog's gastrocnemius under the influence of alcohol was able to perform at first a markedly increased amount of work, but after the period of three or four hours this changed to a decrease; after the elimination of the intramuscular nerve-endings by curare, alcohol had no effect, and its former action was hence ascribed to the peripheral nervous system. The work of the present authors has also been performed on isolated muscle and has also yielded positive results, which, partly agreeing and partly disagreeing with those of Scheffer in his own field, have covered a wider range.

It is perhaps only natural that those who chance to read the present article may be tempted to apply to the human being the facts here presented. This, the authors, who have made no experiments on man, have deliberately refrained from doing. While it is not at all improbable that the general facts discovered with frog's

¹ KOBERT: *Archiv für experimentelle Pathologie und Pharmakologie*, 1882, xv, p. 73.

² SCHEFFER: *Ibid.*, 1900, xlv, p. 24.

muscle may be true also of human muscle, we would warn all readers against assuming that the same quantitative relations prevail in the two species. Experimental pharmacology has revealed innumerable instances of a drug acting upon two species with qualitative similarity but with quantitative inequality.

METHOD.

Our experiments have been made upon healthy, active frogs, the common leopard frog, *Rana virescens*, having been used in all except one series, in which young bullfrogs were employed. In all except a few of the earlier experiments, where commercial ethyl alcohol was used, we have employed Squibb's absolute ethyl alcohol, diluted in various known proportions with distilled water. So far we have made no experiments with any variety other than ethyl alcohol. In the majority of experiments alcohol alone was given, but in one series curare was also administered.

Our usual procedure has been to ligate one leg and then to inject the solution either into the dorsal lymph sac or into the stomach. Thus the drug was able to enter the circulation and reach all parts of the body except one leg. The non-alcoholized leg was at once amputated, and its gastrocnemius muscle was excised and prepared in the usual way for stimulation. In all cases the stimulation was direct, never through the nerve. In most of the experiments sixty opening induction shocks per minute were given and continued until the muscle was exhausted, the contractions being recorded on a very slow drum by the isotonic method. In twenty to seventy-five minutes (in the majority of the experiments about forty-five minutes) after the injection of the alcohol the frog was killed, and the alcoholized gastrocnemius was removed and studied similarly. Thus from each animal records were obtained from a non-alcoholized and an alcoholized muscle. From the records a comparison could readily be made of the number and extent of the contractions, of the total amount of work that each muscle was capable of doing, of the oncoming and course of fatigue, and of various other phenomena. For certain specific purposes this method of study was at times altered in certain ways. Thus, in studying the total amount of work performed by the muscle, instead of recording the contractions graphically a work-adder was sometimes found convenient. Further, a series of experiments was performed in which, instead of the stimulation occurring at regular intervals of time, the muscle at the end

of each relaxation closed a circuit and thus stimulated itself anew. This enabled a record to be made of the total number of the possible contractions and relaxations in a given time. In another series a single contraction curve of the alcoholized muscle was superimposed on that of the non-alcoholized, and thus a comparison of the detailed features of the two contractions was made possible.

There appear to be wide variations among frogs in the rate of absorption of alcohol, a phenomenon which has been observed likewise of other animals with the same drug. Ordinarily symptoms of intoxication, such as sluggishness, appear within a few minutes after the injection, but not infrequently all symptoms are greatly delayed. In our earlier experiments we were careful to administer the alcohol in known quantities of the desired solution per gram of frog. But the great variation in absorption made such care superfluous, and later we merely filled the dorsal lymph sac or the stomach fairly full of the solution and waited the desired time before preparing the muscle. At first sight it might seem that we employed with each animal somewhat large quantities of the drug, but the quantity which we introduced into the body is only broadly suggestive of the relative quantity which the muscle actually received. Of greater importance in this respect is the strength of the solution, a stronger solution having an effect differing in kind from that of a weaker one. Yet with any one percentage employed our results show a considerable range of quantitative variation, which seems to be due in part to the varying rate of absorption. It would be interesting to investigate the cause of this latter phenomenon. In all our experiments care was taken to make the record with the muscle at once after removing the latter from the circulation.

We have been especially careful to take into consideration and eliminate the various possible causes of error. It is a well-known fact that under normal circumstances corresponding muscles on the two sides of the body are capable of performing very different amounts of work. A few preliminary experiments made it probable that any error arising from this source would not usually exceed 10 per cent of the whole amount of work performed. Our results obtained with alcohol are far in excess of this. Some of our earlier experiments suggested the idea that in the frog the right gastrocnemius is normally stronger than the left. Enough control experiments were made to show that this is not true, but that the average capacity for work is approximately equal on the two sides.

The number of experiments that we have performed is approximately two hundred. It is thought that with this large number any possible errors due to individuable variation have been eliminated.

The work was carried on during the months of January to June, 1901, inclusive, and December, 1901, to May, 1902, inclusive.

RESULTS.

We have found that the action of alcohol on muscle varies with the relative quantity of the drug employed. Our experiments may be arranged in three groups, according as small, medium, or large quantities were used. In brief it may be stated that alcohol in small quantity has no appreciable action; in medium quantity it is favorable to activity; in large quantity it is unfavorable to activity.

1. **Action of alcohol in small quantity.**—A few experiments were tried with 0.03 c.c. of 10 per cent alcohol per gram of frog, administered for forty-five minutes. The results were by no means uniform, showing in some cases a greater, in some a less working power in the alcoholized muscle. But all these variations were within the limits of error, as exhibited by a comparison of normal muscles under equivalent conditions, and hence the results are not to be ascribed to a possible action of alcohol. In other words, alcohol in the small proportion used does not appear to exert any action whatever on muscle tissue. Scheffer claims to have demonstrated in *Rana esculenta* a favorable action in the proportion of 1 part by weight of pure alcohol to 1000 parts of body weight. Taking this as literally 1 gram and not 1 c.c. and computing our results on the same basis, the density of ethyl alcohol being 0.79, we find ourselves unable to demonstrate a genuinely favorable action in doses of 2.37 parts by weight of pure alcohol to 1000 parts of body weight. This slight difference between Scheffer's results and our own we are not able to explain.

2. **Action of alcohol in medium quantity.**—Because of its novelty and the general ignorance regarding it, the favorable action of alcohol has proven of great interest to us and has engaged our especially careful attention.

Let us consider the action of a 10 per cent solution in the proportion of 0.08 c.c. per gram of frog, or, in other words, 40 parts by weight of pure alcohol to 1000 parts of body weight, injected about thirty to forty-five minutes before the testing of the muscle. Fig. 1 shows the graphic record of a typical experiment of this kind.

FIGURE 1.—Experiment 56. Record of contractions of corresponding gastrocnemii; two-fifths the original size; upper, normal; lower, moderately alcoholized; 0.08 c.c. of 10 per cent alcohol to 1 gm. of body weight for 45 minutes; stimuli 1 per second. Total number of contractions or total working time in seconds, = (normal) 363, (alcoholized) 819; percentage of increase = 125.6. Total amount of work in gram-millimetres = (normal) 4614, (alcoholized) 8260; percentage of increase = 79.

The initial contraction of such an alcoholized muscle is often, although not always, slightly less in extent than that of the normal. The phenomenon of the progressive decrease in extent of the four or five so-called "introductory contractions" is more common than in the normal muscle. Following these the contractions show a progressive increase in extent, which is more gradual than is normally the case, the maximum being reached after the muscle has performed often one-fourth, and in some cases one-third, of its total number of possible contractions. As to the actual extent of the maximal contractions there seems to be no constant difference between the muscle with and that without the medium quantity of alcohol, sometimes the former surpassing, at other times the latter, while at still other times no difference is appreciable.

The most striking feature of the record, however, and one of the most prominent phenomena of the experiment is the larger number of contractions of which the alcoholized muscle is capable. In the experiment now presented, the normal muscle made 363 contractions, while that which was under the influence of alcohol made 819, an increase of more than 125 per cent, before an equal amount of exhaustion set in. Other examples are as follows, the average percentage of increase in the twenty-six experiments being 59.5.

TABLE I.

No. of experiment.	No. of contractions of normal muscle.	No. of contractions of alcoholized muscle.	Percentage of increase in number of contractions.
18	274	411	50
34	297	476	60
43	413	572	38.5
44	160	221	38.1
48	530	918	73.3
49	783	772	-1.5
50	634	806	27.1
51	607	750	23.5
52	576	602	4.5
53	611	1225	100.5
54	412	535	29.8
55	489	758	55
56	363	819	125.6
72	422	769	82.2
81	483	792	63.9
83	676	786	16.2
84	650	689	6
85	511	683	33.6
86	317	609	92.1
87	291	881	202.7
88	429	684	59.4
92	623	993	59.4
160	380	849	123.4
166	405	767	89.4
171	665	883	32.9
172	408	665	62.9

This table indicates the great range of quantitative variation which is seen throughout the study of the physiological action of alcohol. It can readily be observed that differences in the rate of absorption exist in different individuals, and to this is doubtless due in considerable part the variation in results. But in how far this phenomenon is responsible, and in how far there are other and unknown causes, it is difficult to say. In this feature our experience is paralleled by that of many other experimenters with the same drug.

Associated with this larger number of contractions, and a phenomenon which is often so marked as to be plainly evident from the record, is the greater amount of work which the alcoholized muscle is capable of performing before exhaustion sets in. In Experiment 56 the total quantities of work, expressed in gram-millimetres, performed by the non-alcoholized and the alcoholized muscles respectively, were 4614 and 8260, an increase of 79 per cent in favor of the alcohol. Other examples are found in Table II, the average increase in all the experiments quoted being 40.4 per cent.

This increase in work is one of the very interesting features of the present research. It is commonly believed that a human being under the influence of alcohol is able to perform, for a certain time at least, a larger amount of muscular labor, and the investigations of Lombard, Frey, Destrée, and Kraepelin, although not agreeing in details, have demonstrated with scientific exactness this main fact. But until Scheffer's work of two years ago it had not been conclusively shown that this increase is a function of the muscle and not of the central nervous system. In this feature our results agree essentially with those of Scheffer, a difference being that we have found it necessary to use larger quantities of alcohol than he, a fact of minor importance. It is a gratification to be able to confirm so fully the findings of his experiments. It can hence be accepted without question that with the help of a moderate quantity of alcohol a muscle itself working continuously and until exhaustion sets in, is capable, quite apart from the central nervous system, of doing a greater amount of work than a similar muscle without alcohol.

Associated further with the larger number of possible contractions is the delay in the oncoming of fatigue and exhaustion. In Experiment 56 the actual time during which the normal muscle was able to perform contractions when stimulated once every second was 363 seconds, which is to be compared with 819 seconds for the alcoholized muscle, the increase being 125.6 per cent. The table

TABLE II.

No. of experiment.	Total amount of work, in gram-millimetres, performed by normal muscle.	Total amount of work, in gram-millimetres, performed by alcoholized muscle.	Percentage of increase in total amount of work.
43	2613	3759	43.8
44	994	1173	18
47	3315	5034	51.8
48	5292	7812	47.6
49	5271	6673	26.59
50	5115	5952	16.3
51	6481	6993	7.9
52	5568	6048	8.6
53	3654	7970	118.1
54	4468	6661	49.08
55	5136	6492	26.4
56	4614	8260	79
72	2716	5710	110.2
73	2821	3078	9.1
81	5049	6156	21.9
82	4576	7222	57.8
83	3186	3501	9.88
84	4043	4806	18.87
85	6222	7894	26.87
86	3375	6564	94.48
87	3456	6229	80
88	4940	6468	30.9
89	5184	6829	31.7
90	2511	2808	11.8
92	9058	10310	13.8

on page 66 will indicate the actual working time of the muscles in question, if in the second, third, and fourth columns the words, "number of contractions" be replaced by "total working time in seconds." In the twenty-six experiments there quoted the average prolongation of the working time, due to the alcohol absorbed, was 59.5 per cent of the normal working time, a result as remarkable and as interesting as the increased amount of work. In the experiments in the two tables above given, of which we have the records of the increase both of working time and of amount of work performed, we find the average of the former to be 56.5 per cent, of the latter 42.4 per cent; that is, the working time seems to be increased to a somewhat greater degree than is the total amount of work accomplished. In considering this prolongation of working time, or delay of fatigue, the conditions of the experiment should be kept in mind. The two muscles, the one normal and the other alcoholized, are stimulated at the same rate. The necessity of adhering to this condition will be appreciated later, when we come to study the matter in another way (page 70).

A final feature recognizable from the graphic record now under discussion is the more pronounced contracture in the normal muscle. This is characteristic of nearly all our curves. It begins fairly early and increases at first slowly, but it is especially pronounced and increases rapidly toward the close of the experiment. It is obviously due to the inability of the muscle, during the brief interval of one second between two stimulations, to complete its activity and relax to its previous state, and the lesser contracture of the alcoholized muscle suggested to us that

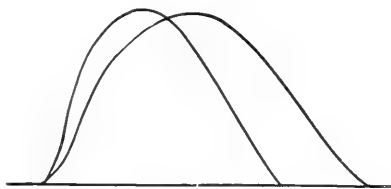

FIGURE 2.—Experiment 189. Curves of single contraction of corresponding gastrocnemii; original size; slower, normal; quicker, moderately alcoholized: about 0.08 c.c. of 10 per cent alcohol to 1 gm. of body weight for 25 minutes.

the drug may quicken the whole process of muscular activity. We proceeded to investigate this by superposing the muscle curves, and we obtained such a result as is shown in a clear-cut manner in Fig. 2. This reveals the interesting fact that by the agency of the alcohol both the phases of the process, both contraction and relaxation, are actually shortened in time. It is well-known that, of the two phases, relaxation is in general more readily

influenced by external agents than contraction, and we find this to be the case with alcohol: *i. e.*, the internal processes expressing themselves outwardly by contraction are quickened to a certain degree, those expressing themselves by relaxation are quickened to a greater degree. In the experiment represented in Fig. 2 the ratio of quickening of the two phases is 1:1.5, but in many cases the effect on relaxation is relatively greater than this.

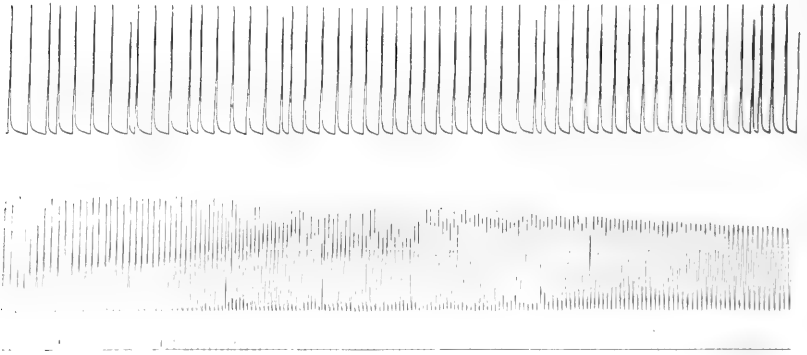

FIGURE 3.—Experiment 138. Record of contractions of corresponding gastrocnemii; original size; upper, normal; lower, moderately alcoholized; 0.12 c.c. of 10 per cent alcohol to 1 gm. of body weight for 20 minutes; stimuli succeeding on complete relaxation. Below is line of seconds. Total number of contractions in 2 minutes = (normal) 53, (alcoholized) 167; percentage of increase = 215.

This phenomenon of quickening led us to a further method of investigation. With quicker action a muscle is able to make in a given time a larger number of complete contractions, and unless, as is rarely the case, these are pronouncedly weak, the muscle is able to perform in the given time a greater amount of work. This can be tested by allowing the writing-lever of the muscle, on complete relaxation, to make an electrical contact, complete a circuit, and thus be the means of stimulating the muscle anew. This we have repeated many times with a result illustrated in Fig. 3. Here in the period of two minutes the normal muscle made 53 complete contractions, the alcoholized muscle 167, an increase of 215 per cent. Even with the diminished extent of the contractions occurring in this experiment, a feature not universally present, the alcoholized muscle performed in the same time an amount of work 2.6 times greater than that performed by the corresponding muscle without alcohol. It is obvious that under such circumstances

a muscle may, and our experiments have shown that it does, often become fatigued or exhausted actually sooner than a normal muscle. This is no contradiction to the conclusion reached on page 67, regarding the delayed fatigue with equal rates of stimulation.

The favorable action of alcohol in moderate quantities seems abundantly proved. This may be summarized as quicker contraction, quicker relaxation, larger number of contractions and increase of work in a given time, larger number of contractions and greater total amount of work before exhaustion sets in, and delay of fatigue.

Is this action exerted upon the nervous tissue within the muscle or upon the protoplasm of the muscle cells? Scheffer was unable to demonstrate any influence of alcohol on the total work of the muscle after the elimination of the nerves by the use of curare, and he concludes that alcohol does not act dynamogenically on the muscular apparatus, but is a true excitant of the peripheral nervous system. Because of its intrinsic interest, and because of the fact that Scheffer expresses himself so decidedly, we have examined this matter with especial care and by many experiments. We curarized the frog by means of an injection of a few drops of a solution of curare into the dorsal lymph sac and, after complete paralysis had resulted, we followed the usual plan regarding the injection of alcohol, testing by stimulating directly at approximately sixty times per minute and recording the contractions until the muscle became exhausted. In each case indirect stimulation was first tried, to convince ourselves that the curare had acted properly, and that no contraction was possible through the mediation of the nerve; and unless this state was reached, the experiment was abandoned. The results were the same as in the experiments already discussed, in which no curare was used. With the curarized and alcoholized muscle there is the same larger number of contractions before exhaustion sets in, the delay of fatigue, the increased amount of work, and the lesser contracture, which indicates quicker action. Fig. 4 is typical of this series of experiments. Here the increase in the number of contractions and the total working time is 80.9 per cent, the increase in the total work performed is 129.2 per cent. From these experiments, the conclusion is unavoidable that the favorable action of alcohol is exerted directly on the protoplasm of the muscle cells and not on the intra-muscular nervous tissue.

A word may be said as to the quantity of alcohol used in obtaining

the favorable effect and the time during which it was allowed to act. Pronounced favorable action was obtained with quantities ranging

from 0.06 c.c. to 0.12 c.c. of a 10 per cent solution per gram of frog; or, expressed in another form, with quantities ranging from 4.74 to 158 parts by weight of pure alcohol to 1000 parts of body weight. Larger quantities of the 10 per cent solution were not tried. It must be borne in mind, however, that doubtless owing chiefly to the very great variation in the rate and quantity of absorption in different individuals, these figures are only broadly significant.

The same may be said of the time required for the action to take place. No action could be assured in a shorter time than twenty minutes. After thirty minutes the stage of increased activity was usually well marked. In most of our experiments we allowed the drug to act forty-five minutes. From one hour on, our observations led us to expect that the favorable action might be replaced by an unfavorable one. But we have not yet made a careful study of the later effects; nor have we yet investigated the power and course of recuperation after the increased work following the injection of alcohol—a subject of evident and considerable interest.

3. Action of alcohol in large quantity. —

A few experiments were performed with commercial ethyl alcohol diluted to 19 per cent and allowed to act for the usual time. In this series the results varied, showing in three of the seven experiments an increase of work and in four a decrease, the

percentage of decrease being the greater. It thus seems probable that with this strength of solution we are approximately on the neutral



FIGURE 4. — Experiment 162. Record of contractions of corresponding curarized gastrocnemii; one-half the original size; upper, normal; lower, moderately alcoholized; about 0.08 c.c. of 10 per cent alcohol to 1 gm. of body weight for 30 minutes; stimuli 1 per second. Increase in number of contractions or total working time in seconds = 80.9 per cent; increase in total work performed = 129.2 per cent.

FIGURE 5. — Experiment 29. Record of contractions of corresponding gastrocnemii; two-fifths the original size; upper, normal; lower, strongly alcoholized; 0.2 c.c. of 33.3 per cent alcohol to 1 gm. of body weight¹ for 45 minutes. Decrease in total number of contractions or total working time in seconds = 73.4 per cent; decrease in total amount of work performed = 92.5 per cent.

zone between quantities causing a distinctly favorable effect and those causing a distinctly unfavorable one. Our observations make it also probable that, owing to individual peculiarities, this zone of neutrality varies greatly with different individuals. A strength of solution favorable to one may easily be unfavorable to another.

With a percentage of $33\frac{1}{3}$ the action in nearly all cases is distinctly unfavorable. In the seventeen experiments in this series the following data were obtained: In four cases the alcoholized muscle either failed altogether to contract with the customary stimulus, or gave to the lever a barely perceptible motion; in three the contractions were very feeble and few in number, as is illustrated in Fig. 5; in eight there was a marked diminution in the amount of work performed, the number and extent of the contractions were much less, and exhaustion ensued earlier than in the normal muscle; in one the detrimental effect of the alcohol was slight and within the limits of individual error; and in one there was a favorable action, characterized by the usual increase of work, greater number of contractions, and delayed fatigue. Thus, of the seventeen experiments, in fifteen there were decidedly unfavorable effects, in one a doubtful, and in one a favorable effect. The action on the individual contractions and relaxations was not studied, but as regards the number of contractions, the working time, and the total amount of work accomplished, the alcohol in the strong solution produced effects exactly the reverse of those observed with the medium solutions, while at the same time the extent of the contractions was less. In all these respects the stronger alcohol is distinctly toxic to the protoplasm and unfavorable to its activity.

CAUSES.

We have aimed to set forth merely the facts which experiment and observation have revealed. A number of possible causes of the phenomena in question may readily be imagined. But it will be of more value to reserve a discussion of these until further experiments, which are now under way, bearing more particularly on the subject of cause, are completed.

One feature in the present research which has proved of special interest to the authors is the fact that it has been possible in the case of a specific narcotic to establish in so clear-cut a manner the fact of a stage in its action which is altogether favorable to the activity of a specific kind of protoplasm. The results suggest that the action of alcohol on other kinds of living substance ought to be very carefully examined, and it is not at all improbable that studies of other narcotics along similar lines might be advantageously followed. The attention of investigators hitherto seems to have been confined too exclusively to the specifically narcotic action of these interesting substances.

SUMMARY.

1. In small quantity ethyl alcohol does not appear to exert any action on frog's muscle.
2. In medium quantity it exerts a favorable action, which is characterized by a quickening of the contraction; a quickening of the relaxation; the power of making a larger number of contractions and of performing a larger amount of work in a given time; an increase in the working time, or, in other words, a delay of fatigue; and the power of making a larger number of contractions and of doing a larger amount of work before exhaustion sets in. This action is exerted directly on the muscle protoplasm itself, not on the intramuscular nerve tissue.
3. In large quantity ethyl alcohol exerts on frog's muscle an unfavorable action, which is, in general, the reverse of that caused by medium quantities of the drug, and is characterized by a decrease in the extent of the contractions; a decrease in the working time, or, in other words, a hastening of fatigue; and the power of making a smaller number of contractions, and of doing a smaller amount of work before exhaustion sets in.

THE IMPORTANCE OF SODIUM CHLORIDE IN HEART ACTIVITY.

By DAVID J. LINGLE.

CONTENTS.

	Page
I. Introduction	75
II. The action of caffein	76
III. The action of oxygen gas in combination with salt solutions	78
a. The action of hydrogen peroxide on heart strips	79
b. Action of oxygen gas on strips in a moist chamber	82
IV. Theories as to the action of salts in causing beats in heart strips	85
V. Facts that do not agree with the calcium theory	86
VI. Facts that support the sodium chloride theory	90
VII. Answers to some of the objections to the sodium chloride theory	96
VIII. Conclusions	97

I. INTRODUCTION.

A RELATIONSHIP has been demonstrated between blood salts and heart activity. The meaning of this is at present unknown, and investigators are not agreed as to the rôle of the various salts involved. Loeb¹ worked with tissues of the rhythmically contracting jelly fish, *Gonionemus*, and came to the conclusion that sodium chloride is of primary importance in rhythmic phenomena, while Howell,² Ringer, and others seem inclined to give calcium a preponderating influence in the reactions originating beats in heart strips.

In a former paper³ the author applied Loeb's ideas to the heart of the turtle, and was led to believe with him that sodium chloride is fundamentally necessary for the origination of rhythmic activity in isolated strips of cardiac tissue.

This article will present some new facts confirming this conclusion and indicating clearly that sodium chloride plays a special rôle in the

¹ LOEB: *Archiv für die gesammte Physiologie*, 1900, lxxx, p. 229.

² HOWELL: *This journal*, 1901, vi, p. 181.

³ LINGLE: *This journal*, 1900, iv, p. 265.

physiology of heart muscle. An attempt will be made to prove sodium chloride a peculiar factor in the complicated chemical and physical interactions that *start* rhythmic action, and at the same time some results will be described that do not agree with Howell's¹ latest theory as to the use of salts in causing the cardiac rhythm.

The results recorded here are true for narrow strips cut from the ventricle of the turtle, that is, pieces of normal tissue *that have ceased to beat as a result of violence inflicted in preparing them for experimentation*; and an answer has been sought for the question, When a strip in this condition begins to beat again in a salt solution, which element is it that renews or permits the renewal of the rhythm? The answer seems to be that it is sodium chloride. The power of this salt in this respect appears to be unique.

II. THE ACTION OF CAFFEIN.

Previous work with heart strips in salt solutions convinced me that unless these contained sodium chloride they could not originate beats. It was found that solutions of lithium chloride, cane-

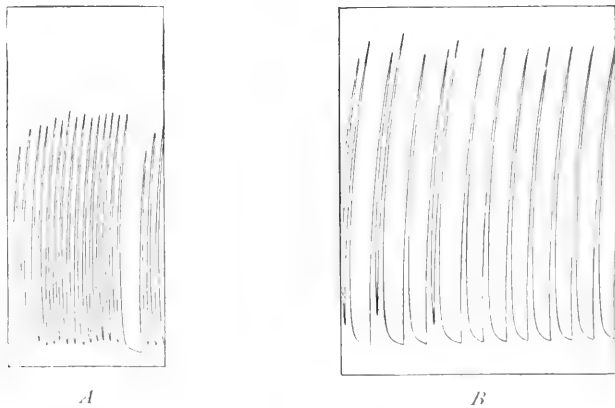

FIGURE 1.—*A* shows the character of beats before caffein was given. *B*. After the drug had acted. Both tracings were made by the same heart strip.

sugar, dextrose, and glycerine were individually unable to re-establish rhythms, nor did they succeed in starting beats when combined with salts of calcium and potassium, using the latter in the proportions considered most favorable for the development of beats. Was this

¹ HOWELL: *Loc. cit.*

failure to establish rhythms due to the absence of sodium chloride; or was it due to something else, possibly a slight physical or chemical obstruction? An attempt was made in the following way to secure an answer to this question. If the absence of sodium chloride from such solutions was not an insuperable barrier to the development of beats, then it might be possible to produce beats in strips without it by increasing the rhythmic power of the tissue. This can be accomplished by using a heart stimulant, and a series of experiments was made to find a stimulant with a marked action on strips from the turtle's ventricle (Fig. 1). Among others caffeine was used. It exerts a decided augmenting influence, and has the additional advantage of being a crystalline compound. A solution made by adding from 5 to 10 c.c. of a saturated solution of the caffeine to enough sodium chloride solution to make one hundred cubic centimetres was found effective. In such a mixture strips beat with greater force, *i. e.* the rhythmic power is intensified. But when caffeine in these proportions was used in combination with sugar solutions and lithium chloride solutions no beats ever appeared in the heart strips, nor did they appear when the most favorable proportions of calcium and potassium salts were added. The solutions used in this series of experiments were the following:—

- Experiment I.* — 90 c.c. cane-sugar $\frac{1}{4}$,
10 c.c. saturated caffeine solution.
- Experiment II.* — 90 c.c. cane-sugar $\frac{1}{4}$,
10 c.c. saturated caffeine solution.
- Experiment III.* — 80 c.c. cane-sugar $\frac{1}{4}$,
10 c.c. saturated caffeine solution,
10 c.c. CaCl_2 0.26 per cent.
- Experiment IV.* — Same, except LiCl solution took the place of sugar.
- Experiment V.* — 89 c.c. cane-sugar $\frac{1}{4}$,
10 c.c. saturated caffeine solution,
1 c.c. KCl solution 0.3 per cent.
- Experiment VI.* — Same, except LiCl replaced sugar.
- Experiment VII.* — 79 c.c. cane-sugar $\frac{1}{4}$,
10 c.c. saturated caffeine solution,
10 c.c. CaCl_2 solution 0.26 per cent.,
1 c.c. KCl solution 0.3 per cent..
- Experiment VIII.* — Same, with LiCl in place of sugar.

No beats were caused by any of these solutions. The controls, however, with sodium chloride developed good beats. It seems then that solutions containing a powerful stimulant like caffeine are unable to start beats unless sodium chloride is present. The experiments also indicate that the series of beats seen in a sodium chloride solution belong to a rhythm originated in the strips, and are not simply microscopic or invisible beats intensified. Gaskell¹ has called attention to the fact that it is not always easy to determine when a heart has really ceased beating. And the same may well be true of strips of the ventricle. Microscopic examinations were also made of the strips, and failed to reveal any beats in quiet strips such as were used in these experiments.

III. THE ACTION OF OXYGEN GAS IN COMBINATION WITH SALT SOLUTIONS.

It has long been known that the heart is extremely sensitive to oxygen and carbon dioxide. These gases also have a remarkable action on heart strips.² Under certain conditions oxygen can originate beats, and in normal beating strips carbon dioxide abolishes them. The action of the two gases in this latter case resembles that of muscarin and atropin (Fig. 2). But in studying the action of salt solutions on heart strips, the important powers possessed by these gases have been ignored, and it is possible some erroneous ideas have arisen in consequence.

Howell³ in his work has paid little attention to the action of oxygen because he was convinced that salt solutions contained the necessary oxygen required by strips taken from the hearts of cold-blooded animals; but this idea is open to objection, for a salt solution evidently cannot supply oxygen at the same rate as the blood, and all hearts respond very quickly to even moderate variations in the oxygen supply of the latter, and beside it will be shown that the addition of oxygen modifies the action of heart strips when they beat in sodium chloride solution and also in mixed salt solutions. Indeed, we may be certain that ordinary salt solutions do not furnish enough oxygen for the moderate activity in heart strips. The investigation of the action of oxygen was suggested by observing that strips active in pure

¹ SCHÄFER'S Text-book of physiology, 1900, ii, p. 185.

² PORTER: This journal, 1898, i, p. 517.

³ HOWELL: *Loc. cit.*

sodium chloride solutions usually beat stronger in the air while a transfer was being made from one solution to another, an effect which a few experiments proved conclusively to be caused by the oxygen of the air. It was found too that sodium chloride and

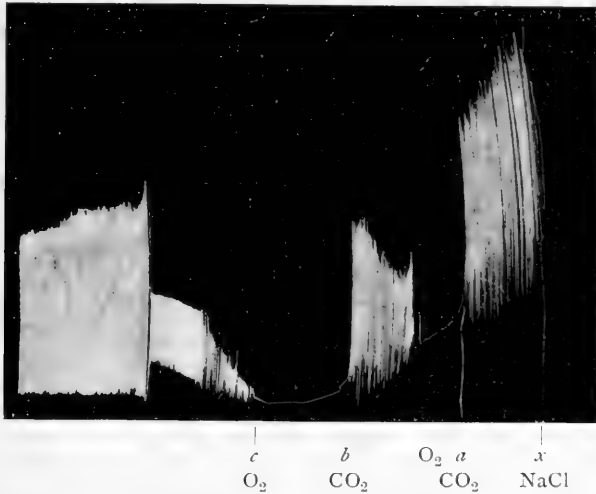

FIGURE 2.—Shows action of oxygen gas on beating strips. At (*x*) beats began in NaCl, at (*a*) the strip was surrounded by CO₂ and beats ceased; O₂ was then added and they reappeared, to be stopped again by CO₂ (*b*), and again started by O₂ (*c*). The drum moved at rate of 18 inches in twenty-four hours.

oxygen are interestingly related. For when strips are treated with sodium chloride and oxygen the beats are stronger and last in favorable cases as long as those in a solution of mixed salts. A study of oxygen effects also throws light on the nature of the so-called sodium chloride arrest. The influence of oxygen can be demonstrated either by placing the heart strips in pure oxygen gas in a moist chamber or by adding hydrogen peroxide directly to the bathing solution.

a. The action of hydrogen peroxide on heart strips.—When two strips are taken from the same heart and one is put into a pure sodium chloride solution and the other into 90 c.c. of sodium chloride solution plus 10 c.c. of a 3 per cent hydrogen peroxide solution, beats begin in both cases. The one with the hydrogen peroxide becomes quickly frosted over with small bubbles of oxygen gas. Some of these break loose and rising form a frothy mass on the surface. This strip always beats stronger and longer than its companion (Fig. 3).

During the very hot weather of the summer of 1891 the strips with

hydrogen peroxide usually beat about three times as long as controls without it. It may be questioned whether this is simply an oxygen effect, for the addition of hydrogen peroxide to a salt solution modifies it in three ways: (1) The salt solution is diluted. This is not the factor which is responsible for the prolongation of the rhythm in hydrogen peroxide, for the same amount of distilled water has no such influence when added to the salt solution. (2) Traces of salts and acid which are always contained in hydrogen peroxide are added to the solution. The salts and free acids were removed by careful distillation, and it prolonged the rhythm the same as the commercial hydrogen peroxide, showing that the salts and acids contained in the commercial hydrogen peroxide are not the cause of the prolongation of the active period. (3) Oxygen gas is given to the strip and the solution. The facts that will presently be given prove that this is the real agent in the experiment.

Not only can hydrogen peroxide improve beats; it can do more. When beats stop in a pure sodium chloride solution, the addition of 10 c.c. of 3 per cent hydrogen peroxide to the 90 c.c. of sodium

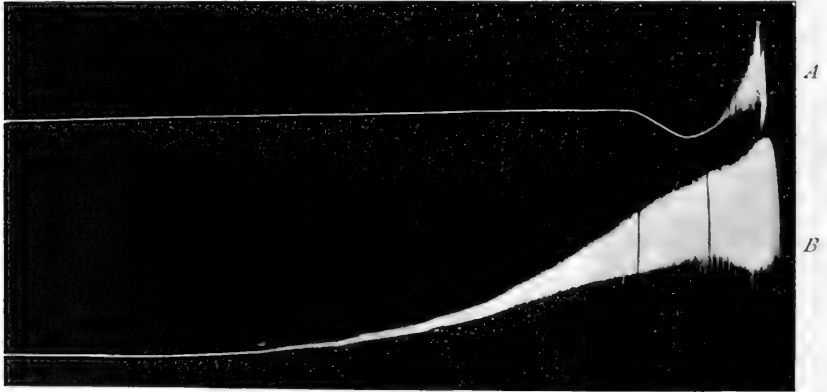

FIGURE 3.—One-half the original size. Shows the effect of H_2O_2 on strips in $NaCl$. These strips were made from the same heart, and the utmost care was taken to have them anatomically and physically alike. The upper strip was in pure $NaCl$, the lower in 93 c.c. $NaCl$ + 7 c.c. of 3 per cent H_2O_2 . The beats in *A* lasted less than one hour, those in *B* almost nine hours.

chloride solution will restore the beats and cause them to continue for many hours.

Howell¹ has made the following summary of the various ways in

¹ HOWELL: *Loc. cit.*

which beats can be restored in strips when they have stopped in pure sodium chloride:—

1. Immersion of the strip in Ringer's solution.
2. Immersion in a mixture of sodium chloride and calcium chloride.
3. Immersion in dextrose or cane-sugar solution.
4. Immersion in lithium chloride solution.

To these should be added the method with hydrogen peroxide. The hydrogen peroxide is added directly to the solution in which

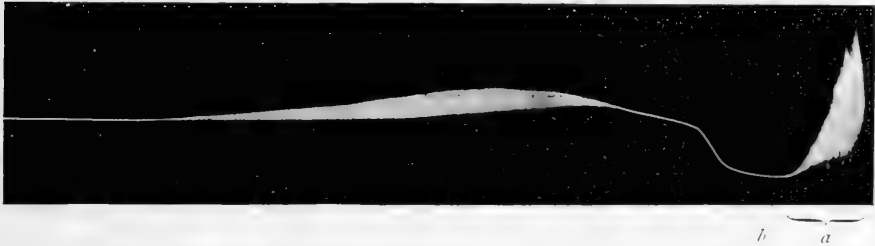

FIGURE 4.—One-half the original size. Shows recovery of beats in a solution of NaCl by adding 7 c.c. of H_2O_2 (redistilled) to the salt solution. (a) shows beats in NaCl lasting from 10.32 to 12.02; (b) when H_2O_2 was added. The drum moved at rate of 18 inches in twenty-four hours.

beats have stopped. Last summer this method was compared with the others, and it was repeatedly noticed that hydrogen peroxide was effective in restoring beats when other solutions failed. In this recovery there is a latent period lasting from thirty minutes to two hours (Fig. 4). Then feeble beats appear. These slowly increase to a maximum which, at its greatest, is always weaker than that in sodium chloride, and then comes a very gradual decline in force. The duration of this second series of beats is from three to fifteen times as long as that seen in sodium chloride alone.

In all these experiments sodium chloride is indispensable. If it is lacking the hydrogen peroxide has no power to originate beats, as is shown by experiments with strips in the following solutions and combinations:—

Experiment I.—

93 c.c. LiCl and 7 c.c. H_2O_2 .

Experiment II.—

93 c.c. cane-sugar $\frac{1}{4}$ and 7 c.c. H_2O_2 .

Experiment III.—

{	10 c.c. H_2O_2 and	{	10 c.c. $CaCl_2$ 0.26 per cent.
	90 c.c. solution		1 c.c. KCl 0.3 per cent.
			89 c.c. cane-sugar $\frac{1}{4}$.

Experiment IV. — $\left\{ \begin{array}{l} 15 \text{ c.c. H}_2\text{O}_2 \text{ and} \\ 85 \text{ c.c. solution} \end{array} \right. \left\{ \begin{array}{l} 10 \text{ c.c. CaCl}_2 \text{ 0.26 per cent.} \\ 1 \text{ c.c. KCl 0.3 per cent.} \\ 89 \text{ c.c. LiCl solution.} \end{array} \right.$

Experiment V. — $\left\{ \begin{array}{l} 10 \text{ c.c. H}_2\text{O}_2 \text{ and} \\ 90 \text{ c.c. solution} \end{array} \right. \left\{ \begin{array}{l} 10 \text{ c.c. CaCl}_2 \text{ 26 per cent.} \\ 1 \text{ c.c. KCl 0.3 per cent.} \\ 89 \text{ c.c. LiCl solution.} \end{array} \right.$

Experiment VI. — Same as *Experiment V*, except that cane-sugar was used in place of the LiCl solution.

Experiments VII and VIII.—Same as *Experiment VI*. LiCl and cane-sugar solutions, but with only 5 c.c. of H_2O_2 .

In none of the above solutions did strips originate beats, though hydrogen peroxide was present and in some cases calcium and potassium also in the proportions considered most favorable to their appearance. Here again it is seen that without sodium chloride a combination of favorable conditions is without power to start beats.

b. **Action of oxygen gas on strips in a moist chamber.**—If heart strips are subjected to an atmosphere of pure oxygen in a moist chamber they show certain peculiarities that strikingly reveal the fundamental importance of sodium chloride in heart beat phenomena. If a strip is placed in sodium chloride solution until beats begin, and then, while beating, is removed to a moist chamber containing oxygen, the force of its beats is strengthened and the rhythm sustained. In some instances beats under these conditions lasted seventy-two hours, and apparently stopped then because putrefaction destroyed the strip. These experiments were made during excessively hot weather, and if putrefaction could have been prevented the strips probably would have contracted longer, for in some cases the lower fourth of a strip was yellow and putrid twenty-four hours before the upper part ceased beating.

Under these circumstances we have a series of rhythmic beats originated under the influence of a bath containing a single salt in solution, and this is sustained in pure oxygen gas as long as rhythms usually are in a solution with a mixture of salts. Such an experiment shows the exceptional position held by sodium chloride among agents that originate heart beats, for treatment with no other solution of a single salt accomplishes the same result. It also may be considered as partially confirming one side of Loeb's theory as to the action of

sodium chloride. In the experiment described beats are only started in the sodium chloride solution. Had the heart strips remained in this they would have stopped after a short time. But the withdrawal from the solution while beats were beginning prevented the development of the unfavorable stage produced by the diffusion of an excessive amount of sodium chloride into the strips, and when this is avoided in the presence of oxygen there is no sodium chloride standstill. Air has the same power as pure oxygen, but its influence is not so marked. In the experiments made with strips taken from a salt solution and exposed to moist air, the contractions were always much smaller than in pure oxygen. Furthermore, oxygen gas, like hydrogen peroxide, can restore beats in strips when they have run down in a sodium chloride solution. If a strip in this condition is removed from the sodium chloride solution, and transferred to a moist chamber full of oxygen gas, a latent period follows, then feeble beats reappear which gradually grow stronger until a maximum is reached, and this is sustained for a long time. The whole series continues twenty-four hours or, in some instances, longer (Fig. 5). In this case recovery occurs without any diffusion of salts, which indicates clearly that the ordinary sodium chloride arrest is largely due to a lack of oxygen.



FIGURE 5.— One-fourth the original size. Shows that oxygen gas will restore beats where they have ceased in NaCl solution. Beats at (a) when in NaCl; at (b) strip was put in moist chamber and surrounded with oxygen gas. The duration of the restored beats was about twenty hours.

These results with hydrogen peroxide and pure oxygen occur only when the strips are under the influence of the salt, sodium chloride. Oxygen of itself is unable to start beats or to sustain those not originated under the influence of sodium chloride. When inactive strips are put into a sugar solution, or any salt solution with hydrogen peroxide, but without sodium chloride, beats never develop. Nor will quiet strips start beating in an atmosphere of pure oxygen without having been treated previously with sodium chloride. An apparent

exception should be mentioned here : sometimes a non-beating strip when put into pure oxygen undergoes regular rhythmic variations in tone. These show slow elongations and contractions, and on a drum making only one revolution in twenty-four hours they look like heart beats. But that the resemblance is only superficial is apparent when it is noted that each contraction and relaxation on the curve represents a period of about fifteen minutes. These are evidently not beats but rhythmic variations in tone, and are not necessarily an oxygen effect. For they were seen in strips in an atmosphere of pure hydrogen, and in the latter case were even better developed. It is possible they belong to the same class of phenomena noted by McWilliam¹ in mammalian hearts during rigor, or to those discovered by Fano² and Botazzi³ in the auricle of the frog. Though, as might be expected, in the turtle's heart they last much longer, in some cases over twenty-four hours.

Apparently, then, oxygen gas cannot of itself start rhythms such as are set up when sodium chloride is present, nor will it restore or sustain beats that have originated independently of sodium chloride. The opportunities of testing this latter point occur but rarely. Sometimes, in exceptional cases, when a ventricle is cut into strips these do not stop beating, and when tied to a lever, records can be made of their contractions. Beats of this kind do not last long, and, of course, originate without the strips coming in contact with a sodium chloride solution. When strips in this condition are put while beating into oxygen gas the rhythm is not sustained. In a typical case it ran down in thirty minutes. Nor would the continued action of oxygen restore the beats again, as it does with those that have stopped under the influence of sodium chloride. In one case out of five instances of this kind observed during the past year and a half, a strip that was beating with unusual vigor was seen after it had run down to make microscopic irregularities in its curve that suggested a rudimentary recovery in the oxygen gas. But these in no way resembled the beats seen in strips treated with sodium chloride.

To sum up the action of oxygen we may say : It cannot start beats when sodium chloride is lacking. Combined with sodium chloride, it increases the force of the beats, and lengthens the duration of the

¹ MACWILLIAM : *Journal of physiology*, 1901, xxvii, p. 338.

² FANO : *Beiträge zur Physiologie*, Carl Ludwig gewidmet, Leipzig, 1887, p. 287.

³ BOTTAZZI : *Journal of physiology*, 1897, xxi, p. 1.

rhythm. It also restores beats in strips that have ceased to beat in a sodium chloride solution. Oxygen and sodium chloride together can maintain beats as long as a mixture of salts, provided the sodium chloride does not act for too long a time. Oxygen will also improve the beats of strips in a solution with a mixture of salts. These facts throw a little light on the rôle of salts in causing strips to beat, and they modify, in some respects, the present theories explaining the rôle of salts in such cases.

IV. THEORIES AS TO THE ACTION OF SALTS IN CAUSING BEATS IN HEART STRIPS.

Two theories have lately been put forward to explain why quiet heart strips renew beats in salt solutions. Loeb¹ has advanced the idea that rhythmic activity is primarily the outcome of oxidase action which sets free energy. Salts are, however, necessary to make physical conditions such that the energy can assume the form of rhythmic action, and sodium chloride produces physical conditions peculiarly favorable to the development of such activity. But only when it acts a certain time; if this is exceeded it produces conditions that are unfavorable. This excessive action of sodium chloride produces the sodium chloride standstill. And he believes the unfavorable condition can be neutralized or overcome for a time by calcium which acts like an antitoxin.

Howell² explains the rhythm-producing power of salt solutions differently. In the first place he believes the heart strips do not beat primarily because there is enough potassium salts normally present in them to inhibit such activity, and he thinks beats begin in a solution of sodium chloride because there the strip losing potassium faster than calcium, after a time enough potassium leaves the strip to weaken its inhibitory power, and beats begin. These result from the interaction of the calcium and the sodium chloride in the strip. He, with Ringer and others, apparently attributes to calcium a preponderating influence in the process; for he thinks that beats continue only so long as a supply of calcium remains in the strip, and that they cease when a certain amount of it has diffused out. The standstill in sodium chloride, therefore, is not due to the diffusion of too much sodium chloride into the strip, but to the diffusing of calcium out of

¹ LOEB: Festschrift für Fick, Braunschweig, 1899, p. 99.

² HOWELL: *Loc. cit.*

the strip. The phenomena of the whole series of beats in sodium chloride is explained, according to this idea, by salt losses sustained in the sodium chloride solution, and not by the special action of this salt in the bathing solution.

Possibly neither of these theories is entirely correct, and a brief discussion of them may help to clear the way for a better understanding of salt action in relation to rhythmic activity. Howell,¹ in his latest paper has presented some objections to Loeb's conception of the effects of sodium chloride. These can be answered more or less successfully. At the same time some facts can be given that do not at all agree with Howell's idea. The point of view of the two theories, it should be noted, is not the same. To Howell certain salts that start a strip beating and keep it beating are the causes of the beat; while to Loeb the processes originating rhythmic activity and those sustaining it are in a sense distinct and more or less antagonistic in nature, and he thinks the inevitable excessive action of the originating agency must be neutralized by some means if beats are to persist. The point we wish to make is that the beginning of rhythmic beats in the strip is associated with the action of sodium chloride, and this is its special rôle. Though if such beats are to persist the sodium chloride action must be sooner or later balanced by calcium or some other salt. Without sodium chloride rhythms do not begin.

V. FACTS THAT DO NOT AGREE WITH THE CALCIUM THEORY.

1. As to beats beginning because potassium diffuses from the strips.

If the diffusion of potassium chloride from the strip were the cause of the beats they should occur in solutions of dextrose, cane-sugar, and lithium chloride, where the diffusion of potassium is not interfered with; but they do not. It is not because these are injurious, for sodium chloride in combination with them causes strips to beat well. Again, the prevention of the diffusion of potassium from the strip should, according to this idea, prevent the origination of beats. When this is done by adding a salt of potassium in varying amounts to the solution about the strip, it is found that heart strips beat in solutions of sodium chloride which contain so much potassium that a loss of this element is absolutely impossible. Beats, for example, have been repeatedly seen to develop in sodium chloride solutions

¹ HOWELL: *Loc. cit.*

containing from 0.03 per cent to 0.4 per cent of potassium chloride. In such solutions potassium does not leave the strip, but rather the strip gains potassium, as is shown by the short duration of the series of beats. With 0.4 per cent of potassium chloride it is not easy to get beats, and when they do occur they last but a few minutes. But the point is, beats are here originated under conditions that are prohibitive according to Howell's theory, and sometimes, though not often, with a large amount of potassium chloride present, they last a considerable time (Fig. 6).

2. If the latent period, as Howell states, represents the time required for a sufficient amount of potassium to diffuse out of the strip, it should be longer in solutions containing more potassium salt than in solutions with less; but this is not so. A large number of experiments were made comparing the action of sodium chloride solution

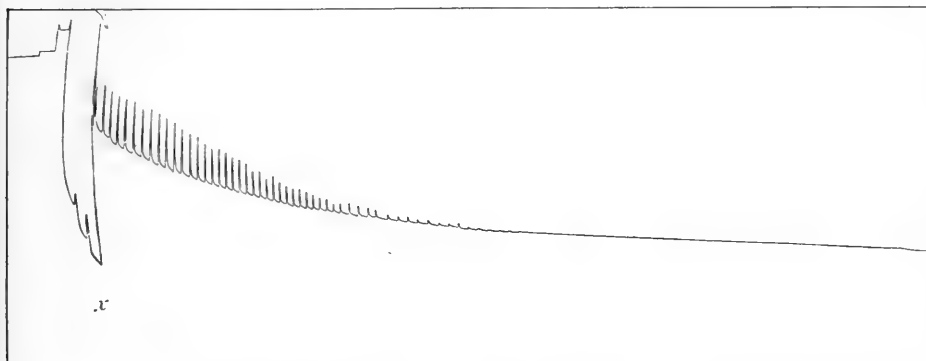

FIGURE 6. — Two-thirds the original size. Shows that beats will originate in NaCl with 0.2 per cent of KCl dissolved in it. In this case they lasted almost four hours. The lever was raised at (x).

alone with solutions of sodium chloride containing potassium chloride in varying proportions, and the results show no constant perceptible difference in the length of the latent periods. It sometimes happens, too, that strips begin to beat within a few minutes after they are placed in a solution of sodium chloride. Here any diffusion of potassium is impossible, while the whole exposed surface comes into instant contact with sodium chloride and may be influenced by it.

3. The second part of the theory states that beats in strips begin when potassium has been removed because then calcium and sodium directly interact in the tissues. As to this point results are not conclusive. It has been impossible so far to eliminate calcium from a strip

and have it beat. For no experiment has been devised that simply accomplishes this; other complications are always introduced. So in dealing with the relative importance of calcium and sodium chloride in the origination of beats we must use indirect or suggestive evidence. We can experimentally differentiate the action of these two elements to some extent. If strips are put into a solution made up of 70 c.c. lithium chloride $\frac{2}{3}$ + 30 c.c. of an $\frac{2}{3}$ sodium oxalate solution, they begin to beat and continue active in some cases as long as three hours. These beats are always feeble, and are apt to show periodic variations in strength. But the point is, here beats are developed in a solution containing more than enough oxalate to precipitate all the calcium in the strip. They develop when the oxalate must be continually throwing down calcium and removing it from any physiological rôle in the tissue, and yet under these conditions beats begin and last for some time. In such a solution no sodium chloride, as such, is given, but there are present in solution both sodium and chlorine ions. That both of these are needed is seen when a solution of lithium chloride and lithium oxalate or of sugar and sodium oxalate is used. With these liquids in each of which one element, either sodium or chloride, is lacking, no beats originate, — at least they did not when the following combinations were used: —

Experiment I. — 70 c.c. cane-sugar $\frac{2}{3}$,
30 c.c. $\text{Li}_2\text{C}_2\text{O}_4$.

Experiment II. — 70 c.c. cane-sugar $\frac{2}{3}$,
30 c.c. $\text{Na}_2\text{C}_2\text{O}_4$.

Experiment III. — 85 c.c. cane-sugar $\frac{2}{3}$,
7 c.c. $\text{Li}_2\text{C}_2\text{O}_4$,
7 c.c. $\text{Na}_2\text{C}_2\text{O}_4$.

Experiment IV. — 70 c.c. cane-sugar $\frac{2}{3}$,
15 c.c. $\text{Li}_2\text{C}_2\text{O}_4$,
15 c.c. $\text{Na}_2\text{C}_2\text{O}_4$.

If a solution which precipitates calcium permits beats to develop when sodium chloride is present, and will not start them if sodium chloride is lacking, it indicates that sodium chloride does more than calcium in originating beats. Even under extreme conditions of this kind it is possible to get beats started, for example, in a solution containing 50 c.c. sodium chloride and 50 c.c. of oxalate solution, and sometimes, though it is rare, these oxalate solutions can start beats when potassium chloride also is present to the extent of

0.06 per cent in the solution. Such a liquid constitutes an exceedingly unfavorable medium for the development of beats, according to Howell's theory, and yet beats occur if sodium chloride is present, and not otherwise.

4. In his paper Howell¹ attributes the arrest in sodium chloride to a lack of calcium in the strip. It occurs, he says, when the strip has lost by outward diffusion a certain percentage of its calcium. The experiments previously described, with oxygen and hydrogen peroxide, make this explanation without modification unsatisfactory. If a strip that has ceased beating in 93 c.c. of a sodium chloride solution be given about 7 c.c. of hydrogen peroxide it begins to beat again and continues active for hours, notwithstanding the previous calcium loss and the fact that calcium is under these conditions, according to the theory, leaving the strip continually. If the arrest in the first instance was due to a loss of calcium, how could the addition of a little hydrogen peroxide restore this? From the beginning of such experiments to the end calcium diffusion had gone on, we may suppose, uniformly and continuously, and yet during this time beats in the strip had begun, grown to a maximum, declined and disappeared, reappeared, increased to a second maximum, and slowly disappeared a second time. The variations in activity in such a case do not correspond with the history of calcium in the strip. If calcium is indispensable for the origination of beats the strip when it stopped in sodium chloride must have had enough calcium left in it for the second series of beats, as no new calcium was given to it in any form. Hence it is difficult to see how the strip can be so sensitive to a lack of calcium that this could be the cause of the arrest as ordinarily described.

A study of the action of oxygen shows that the onset of the arrest as seen in sodium chloride is greatly accelerated by a lack of oxygen in the salt solution. If oxygen is furnished the arrest is postponed for hours in some cases. And it is possible that the arrest as usually observed with sodium chloride solution is intensified or caused by something related to mild asphyxia. That the ordinary arrest cannot be due to a lack of calcium and that calcium is not so fundamental, was further demonstrated by some experiments made with solutions of sugar and sodium chloride. When a small amount of sodium chloride, 16 to 18 c.c. $\frac{1}{8}$ solution, was added to 100 c.c. of a sugar solution, strips sometimes remained quiet in this mixture for twenty-

¹ HOWELL: *Loc. cit.*, p. 206.

four hours and then began to beat. A similar result was seen when sodium citrate was used in place of sodium chloride. If a strip stops in a solution of sodium chloride after two or three hours' immersion because too much calcium has left it, how is it possible for a strip to begin beating in a sugar solution after calcium diffusion has gone on for nearly twenty-four hours? In the sugar solution calcium diffusion, so far as we know, occurs just as rapidly as in a solution of sodium chloride. Either the calcium does not diffuse rapidly or it is not fundamental for the origination of beats, unless in the presence of oxygen, and in sugar solutions containing a small amount of sodium chloride, less of it can do the work. This idea, that calcium is not so essential as sodium chloride for the origination of beats, is supported by some work of Loeb's¹ in which he has shown that calcium actually inhibits rhythmic beats in striped muscle and in *Gonionemus* tissue. That it also acts as an inhibitory factor in nerve tissue seems not impossible, because when this is treated with reagents like the oxalates its irritability is greatly increased. So that stimuli, ordinarily inactive, become afterward intensely so. It is indeed probable that calcium owes its well-known value as a sustainer of beats to this very restraining power. Possibly it is this very characteristic that enables it to preserve tissue, and it is by holding in check, rather than by causing activity, that calcium is enabled to prolong the active period of heart muscle. If calcium and sodium chloride both caused activity, their interaction should shorten, not prolong, the working time. That this is the normal rôle of calcium is suggested by a study of its action in excess, which, as is well known, always slows beats in heart strips. This slowing tendency may become so great at times that beats entirely stop, — a very clear case of an inhibitory rather than an inciting power.²

VI. FACTS THAT SUPPORT THE SODIUM CHLORIDE THEORY.

1. The fact is well established that sodium chloride solutions are the best of all media for originating beats in heart strips. But is there evidence that in these solutions it is sodium chloride that is the

¹ LOEB: *Loc cit.*

² That the beats in a calcium solution are always stronger than in sodium chloride does not disprove this idea. The beats in calcium solutions usually have a lower rhythm; hence the energy expended in two or more beats in sodium chloride is in calcium solutions combined in a single beat.

effective agent? The following facts may be considered as supporting this idea:—

a. There is the fact that the efficiency of a solution in producing beats in strips is to some extent dependent on the amount of sodium chloride in it. If sodium chloride is the active agent, we should expect this result; but if the beats in sodium chloride are started by the diffusion of potassium, when this is otherwise provided for and physical conditions are maintained, the amount of sodium chloride should be immaterial. But the following experiments indicate clearly that this is not the case.

<i>Experiment I.</i> —	98 c.c. cane-sugar $\frac{1}{4}$, 2 c.c. NaCl $\frac{1}{8}$.	No beats.
<i>Experiment II.</i> —	98 c.c. LiCl $\frac{1}{8}$, 2 c.c. NaCl $\frac{1}{8}$.	No beats.
<i>Experiment III.</i> —	96 c.c. cane-sugar $\frac{1}{4}$, 4 c.c. NaCl $\frac{1}{8}$.	No beats.
<i>Experiment IV.</i> —	96 c.c. LiCl $\frac{1}{8}$, 4 c.c. NaCl $\frac{1}{8}$.	No beats.
<i>Experiment V.</i> —	94 c.c. cane-sugar $\frac{1}{4}$, 6 c.c. NaCl $\frac{1}{8}$.	Seven beats after a latent period of about four hours.
<i>Experiment VI.</i> —	94 c.c. LiCl $\frac{1}{8}$, 6 c.c. NaCl $\frac{1}{8}$.	No beats.
<i>Experiment VII.</i> —	92 c.c. cane-sugar $\frac{1}{4}$, 8 c.c. NaCl $\frac{1}{8}$.	No beats.
<i>Experiment VIII.</i> —	92 c.c. LiCl $\frac{1}{8}$, 8 c.c. NaCl $\frac{1}{8}$.	No beats.
<i>Experiment IX.</i> —	90 c.c. cane-sugar $\frac{1}{4}$, 10 c.c. NaCl $\frac{1}{8}$.	Good beats lasting nearly one and one-half hours.
<i>Experiment X.</i> —	90 c.c. LiCl $\frac{1}{8}$, 10 c.c. NaCl $\frac{1}{8}$.	Latent period about four hours. Irregular beats one hour.
<i>Experiment XI.</i> —	88 c.c. cane-sugar $\frac{1}{4}$, 12 c.c. NaCl $\frac{1}{8}$.	No beats.
<i>Experiment XII.</i> —	88 c.c. LiCl $\frac{1}{8}$, 12 c.c. NaCl $\frac{1}{8}$.	Long latent period, three and one-half hours. Beats last- ing over two hours.

- Experiment XIII.* — 86 c.c. cane-sugar $\frac{1}{4}$, A very long latent period, of
14 c.c. NaCl $\frac{1}{8}$. five hours; then beats lasting
two and one-half hours; then
pause of about seven hours,
and then again for five hours.
The last of these occurred over
twenty-six hours after strip was
put into the salt solution.
- Experiment XIV.* — 86 c.c. LiCl $\frac{1}{8}$, Latent period about four hours.
14 c.c. NaCl $\frac{1}{8}$. Good beats lasting one hour.
- Experiment XV.* — 84 c.c. cane-sugar $\frac{1}{4}$, A latent period lasting twenty-
16 c.c. NaCl $\frac{1}{8}$. two hours; then very strong
beats that were going vigor-
ously twenty-five hours after
the strip was put into the
solution.
- Experiment XVI.* — 84 c.c. LiCl $\frac{1}{8}$, Latent period of six hours.
16 c.c. NaCl $\frac{1}{8}$. Beats lasting about one hour;
not so strong as those in sugar.
- Experiment XVII.* — 82 c.c. cane-sugar $\frac{1}{4}$, Latent period about one and
18 c.c. NaCl $\frac{1}{8}$. one-half hours; very power-
ful beats lasting twenty-four
hours. (In this there were
two periods of inaction, each
about one hour long, and
a third one of about four
hours. The beats at the end
of the twenty-four hours were
almost invisible. The rhythm
showed periodic groupings
throughout.)
- Experiment XVIII.* — 82 c.c. LiCl $\frac{1}{8}$, Latent period three hours. Very
18 c.c. NaCl $\frac{1}{8}$. powerful beats, lasting about
two hours. A typical NaCl
series.

This series of experiments was made on strips taken from nine different hearts. If they could have all come from the same heart there would doubtless have been greater uniformity, as it is well known that there is considerable difference in the reaction of different hearts

to salt solutions. Nevertheless the results show that the origination of beats, the duration and the character of beats are determined by the amount of sodium chloride present. If sodium chloride is the important factor in causing beats these results agree with expectations. But if Howell's ideas are correct they are incomprehensible. In these cases the loss of potassium and calcium was not interfered with. The only factor changed was the amount of sodium chloride present. In experiments fifteen and seventeen, both in cane-sugar, latent periods of almost twenty-four hours' duration occurred, and then vigorous beats began. Then, too, such beats occur and last for over twenty-six hours in some cases, where sodium chloride is dilute, a case of retarded development of the toxic stage. When it is strong, one-eighth normal, they never last so long. The beats in sugar solution are the remarkable ones, and this is in accord with the fact that heart strips sometimes beat for a time in this solution alone, — a fact as yet unexplained.

(b) The experiments with oxygen gas prove that sodium chloride is a remarkable factor in originating beats. When strips are placed in sodium chloride long enough to start beats, and are then transferred to an atmosphere of oxygen, they continue active as long as they ordinarily do in mixed salt solutions. In this case calcium is not needed in the bath because the short stay in sodium chloride does not cause injurious effects. It may be objected that the long duration of beats in this case results because calcium could not diffuse out of the strip when it was in the oxygen, and so calcium as much as sodium chloride is responsible for the beats. From the nature of the case here we cannot prove the contrary. But the indirect evidence previously given is against this, and in addition to that we may state the following points to indicate that calcium is not the more important factor in the case under discussion:

(1) The fact that in solutions with hydrogen peroxide present where calcium diffusion goes on, beats are very slowly abolished.

(2) The fact that strips can remain in sugar solution twenty-four hours and then begin beating and remain active much longer, indicates that beats are possible in sodium chloride after a very long outward diffusion of calcium, even after sufficient time has elapsed to permit the loss of most of the diffusible calcium. If in these cases the loss of calcium does not prevent beats, how can we consider calcium to be the cause of the beats in strips influenced by sodium chloride and oxygen?

(c) The fact that in sodium chloride solutions beats begin feebly and then increase to a maximum, shows that they originate and develop in the same ratio as sodium chloride enters. The intensity of the phenomena increases as inward sodium chloride diffusion progresses.

(d) Lastly, we have the facts demonstrated by Loeb on ordinary striped muscle. This is not a rhythmic tissue, and calcium, if it be the important factor in rhythmic activity, is certainly not present here in the proportion to develop beats, and yet sodium chloride develops rhythmic activity in this tissue. It has been stated that solutions of thoroughly purified sodium chloride cannot originate beats, but this is not correct. To prove this solutions were made with sodium chloride that had been so thoroughly purified by precipitation with hydrochloric acid gas that no trace of impurity could be detected even with the most careful tests. There was no doubt as to the salt being of the highest purity, for it had been repeatedly tested in the chemical laboratory of the University. This solution started beats just the same as the salt ordinarily used.

That sodium chloride plays a remarkable rôle in rhythmic phenomena is beyond doubt; whether it is unique is a question, and one that cannot be answered until the whole field of inorganic chemistry has been worked over. So far no salt has been found that is able to replace it. We may safely say that when strips of heart tissue beat well and normally they are, or have been, in a solution containing sodium chloride.

If we adopt the physical theories as to the nature of muscular contraction, and regard salts as agents producing those conditions that result in what we call the contraction, then there is no reason why other salts should not be found capable of producing the same changes as sodium chloride. So far in this work but one case of this kind has been noted, and it is by no means satisfactory. When strips were placed in a solution consisting of 30 c.c. of an $\frac{2}{8}$ $\text{Li}_2\text{C}_2\text{O}_4$ solution and 70 c.c. of an $\frac{2}{8}$ LiCl solution, a series of feeble beats was originated which lasted about one and one-half hours. These beats were very irregular and showed a marked tendency to group themselves. The series did not begin gradually and develop to a maximum; the first beat was as powerful as any. The decline, however, was gradual, resembling that seen in sodium chloride. In this case sodium ions in the bathing solution were lacking, but lithium and chloride ions were present, and Dr. Loeb has shown that lithium ions are capable of

replacing sodium ions in striped muscle. But I know of no other instance of this interchangeability in heart muscle. The exception in this case occurs with an ion closely related physiologically and not unlike sodium chemically. Besides, it must not be forgotten that there is another factor here. These beats occurred in an oxalate solution, one that precipitated the tissue calcium, and so may have greatly increased the irritability of the muscle and caused a predominance of sodium chloride in the tissue. In heart tissue in this condition the lithium solution was able to start beats, which it certainly is not able to do in normal tissue. But at best this doubtful ability to do the work of sodium chloride cannot be compared with that of sodium chloride in causing rhythms.

Ammonium sulphate will sometimes cause rhythmic activity in striped muscle. But it will not do so in heart muscle when used in the following proportions: —

1. Normal solution.
2. $\frac{11}{2}$ solution.
3. $\frac{11}{4}$ solution.
4. $\frac{11}{8}$ solution.
5. $\frac{11}{8}$ solution dil. $\frac{2}{5}$.
6. $\frac{11}{8}$ solution dil. $\frac{3}{5}$.

Nor in the following combinations: —

7. 89 c.c. $\frac{11}{8}$ $(\text{NH}_4)_2\text{SO}_4$,
10 c.c. CaCl_2 0.26 per cent,
1 c.c. KCl 3 per cent.
8. 50 c.c. $\frac{11}{8}$ ammonium sulphate,
39 c.c. $\frac{11}{4}$ cane-sugar,
10 c.c. CaCl_2 0.26 per cent,
1 c.c. KCl 3 per cent.
9. 25 c.c. $\frac{11}{8}$ ammonium sulphate,
10 c.c. CaCl_2 0.26 per cent,
1 c.c. KCl 3 per cent,
64 c.c. $\frac{11}{4}$ cane-sugar.

In the controls from the same hearts with sodium chloride in place of ammonium sulphate good beats developed in every case.

VII. ANSWERS TO SOME OF THE OBJECTIONS TO THE SODIUM CHLORIDE THEORY.

Howell¹ makes the statement that sodium chloride without the presence of calcium cannot start beats. This may be true, but the experiment the author gives to prove it is not satisfactory. He says that when calcium is removed from a strip by means of oxalate, treatment with sodium chloride is powerless to start beats; hence it cannot do so without calcium. Howell's experiment is exactly what we should expect according to Loeb's theory, namely, that when calcium is removed from the tissues in this way, the sodium chloride in it not being neutralized is present in sufficient amount to be injurious. In other words, the strip is then suffering from an excess of sodium chloride. If so, it is clear why the addition of more sodium chloride is ineffective; it simply makes matters worse instead of better. This idea is based on the supposition that the normal strip contains sodium and calcium in proportions that nearly, but not quite, balance each other. Calcium is in slight excess and inhibits the strip. It seems to be, as Loeb² has shown, calcium, and not potassium, that prevents strips from beating in Ringer's solution and in blood serum. If beats are to begin in these this calcium must be overcome by sodium chloride of the solution in which it is immersed, or calcium must be diminished in the strip. We can always start beats by the former method, but in heart muscle the latter is not as yet practicable³ because the oxalate, the usual means of getting rid of calcium, seems to be actively injurious in other ways.

In a former paper the series of beats occurring in a strip when it is transferred to a sugar or a lithium chloride solution, after beats have ceased in a solution of sodium chloride, was explained as due to the sugar and lithium chloride permitting the escape of the excess of the sodium chloride that had stopped the beats in the first case, so that favorable conditions for beats again arose. Howell⁴ brings forward the following objections to this idea: (1) It cannot be a sodium chloride effect because the strip still has a supply of cal-

¹ HOWELL: *Loc. cit.*, p. 196.

² LOEB: *Loc. cit.*

³ The experiments described on page 91 with strips in sugar solutions containing a small amount of sodium chloride where beats begin after twenty-four hours' immersion, show that sodium chloride can start beats when, if salts do diffuse out at all readily, most of the diffusible calcium has been removed.

⁴ HOWELL: *Loc. cit.*, p. 197.

cium which can be detected by the ammonium oxalate test. But according to Howell's ideas such strips had stopped previously in sodium chloride solution because there was not enough calcium left in them to keep them going! Now he states that the beats produced in these strips in lithium chloride and sugar solutions result because there is calcium in them. The same amount of calcium in a strip in one case causes a standstill, in another beats. In the sugar and lithium chloride solutions calcium diffusion continues, and the strip should be passing continuously into less and less favorable conditions for beats if calcium is essential. Yet under these circumstances beats begin and continue for some time. Here, again, the calcium history of a strip and its activity do not run parallel courses. The sodium chloride explanation seems simpler and more consistent.

2. Sometimes strips that have made a long series of beats in sodium chloride make but a short series in sugar. The idea is, that if it took a long time for the sodium chloride to enter and cause beats it should take a long time to escape and so cause a long series of beats, but it does not. This fact strongly supports the sodium chloride idea, and it agrees with that theory perfectly. A strip which has been a long time in sodium chloride will be more or less injured. The prolonged action causes permanent injury; hence the return series of beats is naturally shorter in such cases.

3. When a strip is treated with a solution of sodium chloride and sodium oxalate for a period equal to the ordinary activity of a strip in sodium chloride, a transfer to sugar will not cause beats. Possibly this failure results from two things: (a) When treated with oxalate in this way, as has been said, the strip is poisoned, or injured, by an excess of unneutralized sodium chloride; (b) It is also injured by the oxalate. These two causes could together depress irritability so that the strip would not beat in sugar.

4. A strip that has run down in sodium chloride, and has been restored in sugar, does not always beat when sodium chloride is given it again. The answer to this is the same; such strips have been under the influence of sodium chloride a long time, and have sustained permanent injury; if they beat at all they should do so feebly, as is the case.

CONCLUSIONS.

1. Sodium chloride is absolutely necessary for the origination of rhythmic activity in heart strips.

2. Agencies like caffeine that can intensify rhythmic activity cannot originate it.

3. What has been described as the sodium chloride arrest is probably due to a lack of oxygen in the salt solutions. The presence of oxygen in these postpones its development, and starts the rhythms again.

4. Ordinary salt solutions do not contain enough oxygen for normal activity of heart strips.

5. Oxygen gas and sodium chloride, if properly used, will keep strips beating as long as a mixture of salt solution.

6. Oxygen gas has a powerful influence on rhythmic power, but is of itself powerless to originate rhythms.

7. Oxalate solution that precipitates calcium will permit beats to begin if sodium chloride is present.

NOTES ON THE ACTION OF ACIDS AND ACID
SALTS ON BLOOD-CORPUSCLES AND SOME
OTHER CELLS.¹

By S. PESKIND.

[From the *Physiological Laboratory, Western Reserve University.*]

IN connection with a research on the action of numerous laking agents, carried on in conjunction with Dr. G. N. Stewart, large quantities of corpuscles free from serum were required. Efforts were made to obtain them by adding to blood minute traces of hydrochloric acid or ferric chloride. These reagents cause the corpuscles rapidly to sink to the bottom of the vessel. It was found that, during the subsequent washing with salt solution and centrifugalization, they lake very easily. With the view of discovering some way of preventing the laking of the precipitated corpuscles, a systematic investigation of the reaction was made. The results are presented in the following brief notes.

1. If to defibrinated human blood, dog's blood, cow's blood, or the blood of a chicken, there is added a very small quantity of most acids or the acid salts of iron, aluminum, zinc, copper, mercury, tin, silver, gold, uranium, and molybdenum, an immediate agglutination and precipitation of the blood-corpuscles takes place. Neutral salts are unable to produce this reaction.

2. The serum constituents play no part in this reaction, since serum-free corpuscles are likewise agglutinated and precipitated by the same reagents.

3. The reaction is due to an effect of the reagents on the stromata of the corpuscles, since, if the serum-free corpuscles are laked by any hæmolytic agent, — *e. g.*, sapotoxin, — and to this solution of blood-corpuscles a trace of any of the precipitants is added, the ghosts are agglutinated and precipitated, settling very rapidly.

¹ These experiments were performed during my tenure of the H. M. Hanna Fellowship. A more detailed report will be made in a subsequent paper.

4. The constituents of the stromata are, according to competent analyses, lecithin, cholesterin, and a globulin which, in all probability, exists as alkali-globulin.

If blood-corpuscles are laked by ether, the lecithin and cholesterin are dissolved out of the stromata, yet the addition of any of the reagents still causes precipitation of the ghosts. Therefore neither the lecithin nor the cholesterin is concerned in the production of this reaction. We must, therefore, look to the alkali-globulin of the stromata for an explanation of the phenomenon.

5. The reagents which precipitate the stromata are also precipitants of alkali-albumin and alkali-globulin, and it seems a warranted conclusion that the reaction is due to a combination of the precipitant with the alkali-globulin of the stromata.

6. A slight excess of the reagent causes precipitation of the corpuscles, but lakes them very rapidly.

7. Laking of the precipitated corpuscles may be prevented by washing several times with ice-cold saline solution and centrifugalizing after each washing. Keeping precipitated blood at 0° C. (*i. e.*, without washing) retards laking for a long time.

8. More than a *slight* excess of reagent prevents agglutination and precipitation of the corpuscles.

9. If corpuscles precipitated by HCl or FeCl_3 are washed five or six times with ice-cold saline solution (centrifugalizing after each washing), the corpuscles will then, on being shaken with saline solution, resume a practically normal suspension, from which they can be reprecipitated by the ordinary reagents.

10. All acids and acid salts cause precipitation of alkali globulin, but certain acids and acid salts do not precipitate stromata and intact blood-corpuscles. Intact corpuscles were found not to be precipitated by osmic acid, boric acid, uric acid, hydrogen sulphide, carbonic acid, arsenious acid.

The only acid salts which would precipitate intact corpuscles were those mentioned in paragraph 1 including the acid sulphates of sodium and potassium.

Why certain acids and acid salts do not precipitate the stromata and the intact corpuscles, I cannot at present say. It will perhaps be found that the penetrability of the corpuscles for a given acid salt determines whether or not this reagent will cause agglutination and precipitation of the corpuscles. If this be the case, then we have a ready means of determining whether any given metallic base pene-

trates the corpuscles, — *i. e.*, by seeing whether the acid salts of this base cause precipitation of the corpuscles. There is reason to believe that in this reaction the reagents do not penetrate the corpuscles to any great distance, but combine with the envelope and remain close to the surface. The envelope is made sticky, which accounts for the agglutination.

11. Leucocytes,¹ thoroughly washed, are strikingly agglutinated and precipitated by the same reagents which act on red blood-corpuscles. The blood separated into two layers,—an upper milky layer of serum containing a larger number of leucocytes and absolutely no red cells, and a lower layer containing the red cells and some leucocytes. Some of the upper leucocytic layer was diluted with saline solution, centrifugalized, and washed. The sediment, consisting purely of leucocytes, was used in my experiments.

Halliburton has shown that leucocytes contain the same globulin (called by him β globulin) as the stromata of the red blood-corpuscles. (This globulin is found to have fibrinoplastic properties.) The reaction in the case of leucocytes (*i. e.*, the agglutination and precipitation) is therefore, in all probability, due to a combination of this β globulin with the reagents.

12. This β globulin is a constituent of all typical cells, — *e. g.*, liver cells, kidney cells, — and reasoning by analogy from the chemical constitution of the stromata (which form the framework of the red blood-corpuscles), I believe that this globulin forms part of the framework, or at least the envelope, of all these typical cells. If this be so, then the reaction (*i. e.*, agglutination and precipitation) must show itself to be of a general nature and not confined to blood-corpuscles. On trial, this was found to be actually the case. Spermatozoa, yeast cells, bacilli, the mycelia and spores of a fungus, and ciliated epithelium, were all found to give the reaction.

Spermatozoa, washed free from spermatic fluid, are agglutinated and precipitated by ferric chloride, although the reaction was not obtained with copper sulphate or HCl.

Yeast cells show marked agglutination and precipitation, if they are suspended in saline solution and then treated with a little ferric chloride. A solution of peptone in 0.9 per cent saline was inoculated with a motile bacillus. After several days the bacteria were centrifugalized and washed several times with saline. The bacilli, sus-

¹ The leucocytes for my experiments were obtained from leukæmic blood kindly given to me by Dr. W. T. Howard, Jr.

pended in saline, were immediately agglutinated and precipitated by small amounts of either ferric chloride or hydrochloric acid solution.

A fungus rubbed up in saline solution gave a suspension of mycelia and spores which under the microscope showed practically no clumping. On the addition of ferric chloride, a flocculent precipitate, consisting of agglutinated masses of mycelia and spores, came down.

Ciliated epithelial cells from the larynx of a rabbit, suspended in saline solution, are agglutinated and precipitated by ferric chloride.

13. The specimen of leukæmic blood investigated contained in its serum an isolysin, — *i. e.*, a substance which caused laking of human colored corpuscles. This blood-serum also caused agglutination of human blood-corpuscles, as well as agglutination, precipitation, and laking of dog's corpuscles.

THE BEHAVIOR OF NUCLEATED COLORED BLOOD-CORPUSCLES TO CERTAIN HÆMOLYTIC AGENTS.¹

G. N. STEWART.

[From the Physiological Laboratory, Western Reserve University.]

ALTHOUGH some preliminary experiments, as mentioned in a former paper,² had shown that nucleated and non-nucleated colored corpuscles exhibit the same general behavior towards NaCl, NH₄Cl, saponin and water, it seemed of consequence to determine with as much exactness as possible how close the resemblance really is, for the following, among other, reasons: (1) If the agreement turned out to be complete it would justify the use of mammalian blood, which has hitherto been alone employed in observations on the permeability of the corpuscles,³ in an investigation designed to throw light on the relation between the life and certain of the selective powers of cells, since nobody, whatever view he may hold in regard to the morphology of the non-nucleated corpuscle, can doubt that the nucleated corpuscle is a cell. (2) The comparison would not be without interest in connection with the morphological relationship of the two kinds of corpuscles. It would be interesting, *e. g.*, to determine whether the behavior of the nucleated corpuscles of the blood of the mammalian embryo was the same as that of the nucleated hæmoglobin-containing elements of the red marrow of the adult mammal and the same as that of the nucleated corpuscles of the adult bird, and whether all the kinds of nucleated corpuscles resembled in their behavior the non-

¹ The major portion of the facts mentioned in this paper was communicated to the American Physiological Society at the Chicago meeting, December, 1901. Additional results were embodied in papers read before the American Association of Pathologists and Bacteriologists at Cleveland in March, 1902, and the British Medical Association (Section of Anatomy and Physiology) at Manchester, in July, 1902.

² Journal of physiology, 1899, xxiv, p. 211.

³ The experiments of G. MANCA and G. CATTERINA (Archivio di farmacologia sperimentale, 1902, i, fasc. ii), on the behavior of the osmotic "resistance" of nucleated corpuscles kept for several days after withdrawal from the body, had not been published when this was written.

nucleated corpuscles of the mammal. Such investigations seemed not incapable of throwing light on the genetic relationship between them. Since, as I have shown, the selection of NH_4Cl in preference to NaCl by the corpuscles depends on their physico-chemical structure, and not on what we call their life, and since some other cells, as pus corpuscles, do not possess this property, the question arises whether it is present all through the development of colored corpuscles, or is acquired at some definite point. It is obvious, I think, that by investigating questions of this kind, not only in regard to the permeability of NH_4Cl , but of urea and all the other substances which easily penetrate the fully formed corpuscles, we may notably supplement our morphological work and throw light on the ancestry of the colored corpuscles, and the nature of the process by which they develop from their colorless predecessors. (3) It seemed not unlikely that such a comparison might bring to light differences in the physiological properties of the nucleus and cytoplasm.

In this paper I shall first describe the behavior of the nucleated corpuscles of fowl's blood to the substances (NH_4Cl , NaCl , saponin and water) already studied in relation to mammalian blood. The behavior of the nucleated corpuscles of embryonic blood and of red marrow in regard to these and other substances will be next investigated. In the third section of the paper, the effects of certain of the laking agents on the corpuscles of *Necturus*, which, on account of their great size, are especially suitable for microscopic observations, will be described. The fourth section will include one or two miscellaneous experiments cognate to the general subject. Detailed discussion of the *modus operandi* of the various hæmolytic agents is reserved for a future communication.

I. THE BEHAVIOR OF FOWL'S BLOOD TO NH_4Cl , NaCl , SAPONIN AND WATER.

In Experiment I, page 127, it is shown that the conductivity of fowl's defibrinated blood is diminished by dilution with water to a much smaller extent than would be the case if a simple solution of electrolytes with the same conductivity as the blood were diluted to the same degree. This is still more conspicuous in the case of a sediment of blood rich in corpuscles. This agrees entirely with the behavior of mammalian blood.¹

¹ Cf. STEWART: Journal of physiology, 1899, xxiv, p. 211.

In Experiment II the behavior of fowl's defibrinated blood to NH_4Cl , NaCl , saponin and water, is compared with that of the defibrinated blood to which formaldehyde had been added. Two specimens of formaldehyde blood, one containing 50 per cent more formaldehyde than the other, were used in order to determine whether the degree of hardening had any influence on the result. In the table, as in all the others, "+ NH_4Cl " means that an equal volume of NH_4Cl solution was added to the blood. "+ NaCl " is the corresponding abbreviation for the NaCl solution; "+ saponin" always means, when no quantity is mentioned, that the saponin solution (unless otherwise noted, a 3 per cent solution of crude quillaia saponin in NaCl solution) was added to the blood in the proportion of 0.4 c.c. of saponin solution to 5 c.c. of blood; "+ water" signifies that the blood had twice its volume of water added to it.

The experiment shows that the nucleated corpuscles, like the non-nucleated, exercise a marked preference for NH_4Cl as compared with NaCl . This is the case also in the formaldehyde blood, although the difference is less, especially when the conductivity is measured immediately after mixture of the salt solutions with the blood. When the mixtures of formaldehyde blood with NH_4Cl and NaCl are allowed to stand, the difference increases continually with the time. There is no notable difference between the two specimens of formaldehyde blood as regards their behavior to NH_4Cl and NaCl , although in both the preference for NH_4Cl , as compared with NaCl , becomes less pronounced as the hardening proceeds. On the other hand, the increase of conductivity produced by saponin is as great in both specimens of formaldehyde blood as in the defibrinated blood, and the relative increase of conductivity produced by water is, if anything, greater in the formaldehyde blood than in the original defibrinated blood.

In Experiment III fowl's blood which had been treated with formaldehyde was followed for twelve days. At the end of that time the blood still behaved very much in the same way as at an earlier period in the experiment, the chief difference being, as in the case of mammalian blood, that the preference of the corpuscles for NH_4Cl , as compared with NaCl , manifested itself more slowly in the later observations, presumably owing to the slower penetration of the NH_4Cl . The preference became very distinct when the mixtures of the salt solutions with the blood were allowed to stand a considerable time.

This experiment also contains a series of observations in which the conductivity of specimens of the defibrinated blood, treated first with formaldehyde, and then after a while with NH_4Cl , NaCl , saponin or water, was compared with that of mixtures containing the same quantities of blood, formaldehyde solution, NH_4Cl , NaCl , saponin or water, but to which the formaldehyde was added after the other reagents had produced their characteristic effects. Certain differences, which, of course, depend on the presence of the corpuscles and would not be found if the electrolytes of the blood were all in simple, homogeneous solution, reveal themselves. The most striking difference is found in the case of the NH_4Cl mixtures, the combination, blood + NH_4Cl + formaldehyde having a distinctly smaller conductivity than the combination, blood + formaldehyde + NH_4Cl . The main reason for this, I suppose, is that the penetration of the NH_4Cl into the unhardened corpuscles in the first combination is more complete, and perhaps its union with some of the constituents of the stroma more intimate than in the case of the hardened corpuscles in the second. In addition, it is probable that a great part of the formaldehyde, which, as a non-conductor, depresses the conductivity of the extra-corpuscular liquid, is in the second case fixed in the corpuscles.

The combinations blood + NaCl + formaldehyde, and blood + formaldehyde + NaCl , do not differ much in conductivity. The slight diminution of conductivity seen in both cases, when the mixtures are allowed to stand for a considerable time, is probably due to a slow penetration of the NaCl into the corpuscles, the permeability of which for NaCl , as was shown in my previous paper,¹ is somewhat increased by formaldehyde, at any rate in the first stages of its action.

The combination, blood + saponin + formaldehyde, has a somewhat smaller conductivity than the combination, blood + formaldehyde + saponin. As mentioned in a previous paper,² a similar difference, but a much more pronounced one, was found in the case of dog's blood, especially when, in the second combination, blood which had been acted upon by the formaldehyde so long that no laking took place on the addition of saponin, was employed. I have already discussed the cause of the difference in that paper. I do not know whether the smaller amount of the difference between the two combinations in the case of fowl's blood than in the case of dog's blood is accidental or not. It may be due to the fact that in Experiment III, the saponin in the first combination had a greater influence than usual in bringing electrolytes out of the corpuscles, and thus increasing the conductivity, since it was added in somewhat more than the usual amount (in the proportion of 0.4 c.c. of the saponin

¹ STEWART: *Journal of physiology*, 1901, xxvi, p. 470.

² STEWART: *Journal of experimental medicine*, 1902, vi, p. 257.

solution to 4 c.c. of blood, instead of 0.4 c.c. of the saponin solution to 5 c.c. of blood). I have shown¹ that the action of saponin on formaldehyde blood is to increase the conductivity of the corpuscles, without necessarily causing any of their contents to pass bodily into the serum.

The combination blood + water + formaldehyde has a smaller conductivity than the combination blood + formaldehyde + water, especially when the measurement is made a considerable time (*e.g.* twenty-four hours), after the addition of the formaldehyde. The result is to be attributed to the depressing effect of the blood-pigment and the excess of formaldehyde in the liquid portion of the water-laked blood on its conductivity, which more than compensates the influence of any electrolytes brought out of the corpuscles by the water.

In Experiment IV the behavior of heat-laked fowl's blood to the four tests is investigated. It will be seen that, as in dog's blood, there is only a slight difference in the conductivity of specimens of blood to which NH_4Cl and NaCl have been added. Only a slight difference in the permeability of the ghosts for the two salts can accordingly exist. What difference there is is in favor of the NH_4Cl . Since the nuclei are still present in the heat-laked blood, and are little if at all altered in microscopical appearance, the experiment indicates that these exercise no noticeable preference for NH_4Cl , as compared with NaCl . Of course it may be that the temperature necessary for heat-laking has deprived the nuclei of this property. But there is other evidence, including the behavior of the unheated nuclei in ammonium chloride solutions, that there exists in this respect a sharp contrast between the nuclear and the extranuclear portion of the intact corpuscles. It is perhaps worthy of mention that the small difference which appears to exist in the permeability of the ghosts to NH_4Cl and NaCl is greater soon after the addition of the salts than later on. I have noticed the same thing in dog's blood. The explanation may be that the ghosts take up NH_4Cl in preference to NaCl , but later on, perhaps on account of some action of the NH_4Cl itself on the envelope or stroma, become incapable of holding it. Even in unlaked blood, both fowl's and dog's, the minimum conductivity of the NH_4Cl mixture, and the maximum conductivity of the NaCl mixture, are reached soon after mixture. Later on, there is a tendency, although it never goes very far, for the conductivity of the former to increase a little, and for that of the latter to fall a little. Even very shortly after mixture,

¹ STEWART: *Journal of experimental medicine*, 1902, vi, p. 257.

in the case of heat-laked blood, the difference is always insignificant, in comparison with that in ordinary defibrinated blood or formaldehyde blood. On the other hand, saponin and water produce a great relative increase in the conductivity of heat-laked fowl's blood, just as in heat-laked dog's blood. When heat-laked fowl's blood is diluted with water, the diminution of the conductivity is relatively smaller than when the unlaked blood is correspondingly diluted. A remarkable effect of heat-laking in fowl's blood is that its conductivity may be greatly diminished by the laking, *e. g.* in Experiment IV, in one specimen of blood from 49.41 to 34.07, and in the other from 49.41 to 29.75. A diminution is often seen in mammalian blood also, but it is never, in my experience, so great as this. Another point of difference is that fowl's blood after heat-laking is much thicker and more viscid than dog's blood.

The fowl's defibrinated blood used in Experiment IV was the same as that used in Experiment III, and it will be seen that in Experiment IV the addition of 0.4 c.c. of the saponin solution to 5 c.c. of the heat-laked blood, whose conductivity was 34.07, raised the conductivity to 66.19; while in Experiment III the addition of the same amount of the saponin solution to 4 c.c. of the unheated blood, whose conductivity was 49.32, raised the conductivity only to 69.26. This shows, pretty clearly, I think, that the final conductivity after the action of a sufficient amount of saponin to cause its full effect, depends on the quantity of electrolytes originally present in the serum and corpuscles, and not on their distribution at the moment the saponin is added.

Before concluding this section of the paper, I may mention that the serum and defibrinated blood of the fowl have, on the average, a considerably higher conductivity than dog's blood and serum. For eight fowls, the average conductivity of the serum was 93.61, and of the defibrinated blood 47.81; while for observations on thirty dogs, taken at random out of a series embracing considerably over one hundred, the average for the serum was 82.71, and for the blood 33.00. If the relation between the proportion of serum and corpuscles to the conductivity of the blood and serum is the same for fowl's as for mammalian blood, this would indicate that the average proportion of serum is higher in the fowl's blood.

II. THE NUCLEATED CORPUSCLES OF THE BLOOD OF THE EMBRYO
AND OF THE BONE MARROW.

Embryo's blood. — I have not been able to obtain a sufficient quantity of embryonic blood for freezing-point determinations. Measurements of conductivity could, of course, be made with a very small amount of blood, but I preferred to devote such scanty supplies as came into my hands to microscopic investigation. The observations here recorded are mainly qualitative. I hope to have another opportunity of making quantitative measurements of the relative resistance to laking of the various kinds of corpuscles, etc. The following is a typical protocol.

Killed a pregnant albino rabbit by decapitation. Collected and defibrinated the blood. Immediately opened the uterus and exposed four embryos, 6.5 cm. long. They showed lively movements. Wiped them dry with blotting paper, then cut the umbilical cord and decapitated each in turn, collecting and defibrinating the blood. The blood of the embryos only yielded a scanty amount of fibrin. From the maternal blood, fibrin was obtained in normal quantity.

Action of sapotoxin. — Twenty-five minutes after the death of the mother, a small drop of the foetal blood was placed on a slide, and at a little distance from it a small drop of a 2 per cent solution of sapotoxin (Schuchardt) in 0.9 per cent salt solution. A coverslip was gently laid on the two drops. The sharp interface between the blood and sapotoxin solution was now observed with the microscope. Rapid laking of the colored corpuscles was seen to go on. Numerous ghosts are left. The nuclei of the corpuscles are not well stained by methylene blue (in 0.9 per cent NaCl) either before or after laking. They seem to break up into granules which stain with methylene blue, and this is the case after all the methods of laking tried. This is in marked contrast to the bird's corpuscles, the nuclei of which stain very well after laking, and retain their original shape, and usually also their original position in the ghosts, the oval outline of which may be made out around them; although, occasionally, the nucleus is displaced and may lie with its long axis in the short axis of the corpuscle, or even be extruded from it altogether. When the 2 per cent sapotoxin solution was stirred up with the foetal blood, complete laking occurred immediately. The same was true of the maternal blood.

Sodium taurocholate (a 2 per cent solution in 0.9 per cent salt solution) also laked both at once. But it caused a greater disintegration than the sapotoxin, and only granular colored masses could be made out, and not complete ghosts. In view of the fact mentioned in a previous

paper¹ that the taurocholate is a more intense leucolytic agent than sapotoxin, it would be of interest to make a quantitative comparison of the relative resistance of embryonic and mature erythrocytes to these substances. Hitherto, however, I have not been able to do this.

Dog's serum which had stood for ten days in the cold (at a temperature of 5° to 8° C.) had practically no effect on the maternal blood. A very small amount of hæmoglobin was seen after twenty-four hours to have gone into solution, the mixture having been kept at ordinary temperature. On the fetal blood, there was a somewhat greater laking effect, and under the microscope it could be seen that a few of the corpuscles were decolorized. Fresh dog's serum (obtained twenty hours after the blood was drawn, from blood-clot kept in the cold) caused (at room temperature) complete, or nearly complete laking of maternal and foetal blood, although the laking proceeded slowly. Under the microscope, it was seen that the nucleated corpuscles discharged their hæmoglobin. But the nuclei did not seem to stain on the addition of methylene blue (in salt solution), only some of the ghosts showing a diffuse staining, or a number of scattered stained granules.

Water laves the foetal blood in the same way as the maternal. A watery solution of methylene blue also, of course, causes complete laking. In the foetal blood, numerous blue granules of various sizes are seen, some free, others apparently lying inside the ghosts. The nuclei seem to break up into these granules. When methylene blue in watery solution is added to foetal blood, to which an excess of 4 per cent formaldehyde solution in 0.9 per cent NaCl solution was added twenty-four hours previously, a diffuse staining of the corpuscles is caused, the nuclei not being well defined. Ehrlich's triacid stain causes the nucleated formaldehyde-hardened corpuscles to assume a reddish color, the nuclei being lighter than the rest of the corpuscles.

A 1 per cent solution of NH₄Cl completely laves both maternal and foetal blood. About four volumes of NH₄Cl solution were added to one of blood. In both cases there is "a period of resistance," during which the corpuscles maintain their shape and color. Then they become large and perfectly round, while still retaining their hæmoglobin. Then, at about the same moment, great numbers of them lose their pigment rather suddenly. Some corpuscles retain their pigment a considerable time longer than the majority. This is true both of the maternal and foetal blood, and indeed of all kinds of blood when submitted to the action of all the laking agents I have used. Eventually these more resistant corpuscles fade out too. A 0.9 per cent or a 1 per cent solution of NaCl causes no laking either in the maternal or foetal blood. The embryonic corpuscles, then, like the adult, are freely permeable to NH₄Cl and not to NaCl

¹ STEWART: *Journal of medical research*, 1902, iii, p. 268.

Amyl alcohol in small amounts lyses fetal and maternal blood with equal readiness.

Heat-laking.—Both maternal and fetal blood mixed with several volumes of 0.9 per cent NaCl are lysed on being heated to 63° – 65° C. In the fetal blood there is almost complete destruction of the corpuscles, only a few ghosts being seen, and no more being revealed by the addition of methylene blue. Numerous granules of blood pigment are seen in clumps. In the blood of the adult mammal the ghosts persist after heat-laking. No nuclei could be seen after laking in the fetal blood. This is in contrast to the behavior of bird's blood.

Bone marrow.—Red marrow was obtained from the proximal epiphysis of the femur of a young dog. Portions of it teased in 0.9 per cent NaCl solution were examined under the microscope and subjected to the action of various laking agents.

Sapotoxin.—With 2 per cent sapotoxin solution in 0.9 per cent NaCl solution, all the cells containing hæmoglobin, large and small, nucleated and non-nucleated, are quickly decolorized, and some of them completely broken up.

Water also decolorizes all the hæmoglobin-containing cells.

NH₄Cl in 1 per cent solution also causes laking of all the colored elements, while NaCl solution of the same strength has no such effect. We must, therefore, conclude that the ancestors of the colored blood corpuscles in the marrow, both erythroblasts and normoblasts, exhibit, at any rate from the moment they acquire hæmoglobin, the preference for NH₄Cl, as compared with NaCl, which is so characteristic of the adult corpuscles.

After all three methods of laking, methylene blue stains the nuclei of the normoblasts and erythroblasts. The outline of the ghost can be easily distinguished, enclosing the nucleus, which is often eccentric in the lysed corpuscles.

Blood from a case of pernicious anæmia.—Blood was obtained, after death, from the kidneys and lungs of a case of pernicious anæmia in which, during life, large numbers of nucleated colored corpuscles were present in the blood stream. There was pronounced diminution in the total number of red corpuscles, and also a diminution in the number of white corpuscles, although in proportion to the red corpuscles the white were increased. Many of the colored corpuscles were crucible-shaped, with a cup-shaped depression at one end which might simulate a nucleus. Many were highly crenated. A good many were larger than normal. All the colored corpuscles are pervious to NH₄Cl, since they are lysed in a 1 per cent solution of that salt. They are also permeable to urea, being lysed in a 1 per cent solution of it. They are impermeable to NaCl,

lake in the normal way with sapotoxin, and lake also when suspended in a 1 per cent NaCl solution and heated to 62°-64° C.

Bone marrow from a case of pernicious anæmia. — Some red bone marrow from a case of pernicious anæmia was also examined. Colored corpuscles decidedly larger than the normal (macrocytes) were rather plentifully present. Nucleated red corpuscles of ordinary size were also seen. All the colored elements were laked by sapotoxin, sodium taurocholate, 1 per cent NH₄Cl solution, and 1 per cent urea solution. The large colorless marrow cells did not seem to be destroyed easily by any of the laking agents used. Sodium taurocholate, which is so efficient a leucolytic agent for the leucocytes of mammalian blood, exerted no special effect on them.

III. THE ACTION OF LAKING AGENTS ON THE COLORED CORPUSCLES OF NECTURUS.

The blood was obtained by making a snip in the heart through the skin. Collected in this way, it clots with great readiness, but by vigorous stirring could be sufficiently defibrinated for microscopic use. The copious and viscid skin secretion, which seemed to be increased while the animal was struggling, was wiped off before the incision was made, so as to prevent it from mingling with the blood.

One of the most striking characteristics of the blood, and one which, in addition to the great size both of the colored and of the colorless corpuscles, renders it particularly useful for the investigation of the action of hæmolytic agents, is the ease with which the hæmoglobin crystallizes, both outside of, and in the corpuscles. This occurs spontaneously when the blood is allowed to stand for some days at room temperature, and instantly, on the addition of sodium taurocholate, sapotoxin, Löffler's methylene blue (owing, mainly at any rate, to the alcohol in it), water and watery solutions of substances like NH₄Cl, which readily penetrate the corpuscles. In extraglobular crystallization the crystals usually assume the form of massive elongated rhombic prisms (Fig. 2). This is the case also in intraglobular crystallization, if the hæmoglobin is well diluted, or a portion of it liberated from the corpuscle before the rest crystallizes, as is apt to be the case when crystallization is induced by the addition to the blood of water (Fig. 1), which, passing into the corpuscles, causes them to swell. It may be here remarked, in passing, that the fact that water induces intraglobular crystallization, is of itself enough to show that the hæmoglobin in the corpuscles cannot be in the form of an ordinary watery solution, since the dilution of

such a solution with additional water would hinder instead of determining crystallization.

With agents like sodium taurocholate (Fig. 4), or Löffler's methylene blue (Fig. 19), which often cause crystallization of the whole or the greater part of the hæmoglobin in a corpuscle before there is time for the liberation of any or much of it, and which do not cause the corpuscles to swell and become globular, as water does, the intraglobular crystals are apt to be more irregular in shape, being apparently moulded, by their mutual pressure and by the contour of the corpuscle, into polygonal masses. The genesis of these masses can be watched under the microscope. After the addition of sodium taurocholate (a 2 per cent solution in 0.9 per cent NaCl solution was always used), although a few corpuscles become broader in the transverse diameter, most of them preserve approximately their original dimensions. Longitudinal wrinkles, and less frequently transverse wrinkles, appear in many corpuscles, due apparently to the puckering of the envelope for whose existence evidence will be presently produced. The hæmoglobin-containing substance of the corpuscle breaks up into round or oval globules of different size. There may be seven or eight or more in one corpuscle. The edges of the globules are faint at first, but rapidly grow more distinct, the outlines at the same time becoming less round and smooth, and ultimately angular. Either the whole mass of the hæmoglobin passes bodily from the colloid to the crystalline condition, or, if we assume the existence of a stroma in which the hæmoglobin is contained, and for the existence of which there seems to be a considerable amount of evidence, the relation of the pigment to the stroma is altered by the hæmolytic agent and the hæmoglobin crystallizes *in situ* in the stroma. Pressure on the coverslip does not generally displace the crystals, which are evidently kept in position in some way in the corpuscle, probably by the stroma. As the crystals grow more distinct, the outline of the nucleus does so too, while the border of the corpuscle becomes fainter, although it can often be seen, still in its original position, after complete formation of the crystals, following their angles and sinuosities so as to include them all. Later on, the envelope may completely disappear, as if dissolved by the bile salt. When a drop of blood and a drop of the taurocholate solution are allowed gradually to mingle on a slide, complete laking, with no intraglobular crystallization may be observed near the interface, where the solution of the laking agent is strongest, and where accordingly the hæmoglobin

is liberated at once, before it can crystallize in the corpuscle. A little farther from the interface, typical intraglobular crystallization may be observed. Sometimes the intraglobular crystals are very numerous, small, and granular looking. Sometimes the opposite extreme is seen, nearly the whole of the pigment in a corpuscle crystallizing in one mass, in which the nucleus is imbedded. The nucleus may partially project from the crystalline mass (Fig. 22), or it may be completely enclosed in it. In this case, the ends of the corpuscle are apt to be colorless, as if the hæmoglobin here had been liberated before it had time to crystallize inside (Fig. 20, 22). It may indeed not infrequently be seen that the poles of the corpuscle are earliest attacked by hæmolytic agents, and sometimes one before the other. A fraying out of one pole, as if it were being corroded, is sometimes observed. Occasionally, however, the opposite may be seen, namely, a crystal of hæmoglobin occupying each pole of the corpuscle, the rest being entirely colorless and filled up with the swollen nucleus (Fig. 28). The taurocholate does not at first affect the size of the nuclei, which continue to show clearly the granules that represent the nodes of the intranuclear network. Later on, the nuclei become much swollen, though still oval in shape, filling the whole corpuscle, except a small portion at the two poles. The intranuclear network now has the appearance of fine instead of coarse granules, as at first. That there is something (resistance of the nuclear membrane to distention or resistance of the stroma pushed towards the poles) which even in the completely laked ghost prevents the nucleus from filling the whole corpuscle, is well shown in Fig. 26, 27. When swelling of the nucleus takes place after the hæmoglobin has crystallized in the corpuscle, the crystals may be seen to separate farther from each other as the nucleus swells, being doubtless mechanically forced apart. The same thing may be observed under the influence of other agents, and even in hardened corpuscles, when no crystals are present, a fragmentation or fissuring of the corpuscle may be produced by the swelling of the nucleus. Sometimes the taurocholate may cause complete disappearance of the nucleus after swelling.

Sometimes the corpuscles show a curious twist at one or both ends. It was seen that this was caused during the spinning of the corpuscles. Probably the rigidity of the corpuscle is lessened by the bile salt, and bending under stress is apt to take place where it is thinnest, namely, at the poles. The twist may be seen both in cor-

puscles which retain their hæmoglobin (Fig. 21), and in completely laked corpuscles (Fig. 26, 27).

The leucocytes swell little, if at all, under the influence of the bile salt, although they may become dim.

Water. — Water causes well-marked agglutination of the colored corpuscles before laking. The corpuscles then swell and become globular. Some of the nuclei may escape from the ghosts and swell up, the network disappearing. They then stain, as all swollen nuclei do, diffusely and faintly with methylene blue. In the corpuscles which have not yet lost their hæmoglobin, the nuclei stain deeply and show the network. The best way to get intraglobular crystallization with water, is to put not too large a drop of water on a slide, and let it gradually mix with the blood under the slip. In some corpuscles, a single hæmoglobin crystal forms, the pigment in the rest of the corpuscle remaining for a time uncrystallized. When this is the case, the corpuscle is pale in the immediate neighborhood of the crystal, indicating either that all the pigment from this portion of the stroma has been gathered into the crystal, or that the liberation from the corpuscle of a portion of the hæmoglobin of this part of the stroma has gone hand in hand with the crystallization of the rest. Sometimes when a crystal stretches right across a corpuscle, the ends may be seen to be curved in correspondence with the boundary of the corpuscle, and not to project through it. In some corpuscles the whole of the hæmoglobin may be seen to be crystallized. As already remarked, this cannot be reconciled with the theory that the hæmoglobin exists in the corpuscles in ordinary aqueous solution. Indeed I do not think that anybody who studies the influence of reagents on these magnificent objects, and particularly the phenomena of intraglobular crystallization, can believe that the corpuscles are merely little bags or vesicles containing hæmoglobin solution, as some physiologists seem to suppose.

Marked swelling of the leucocytes is caused by water. Their nuclei also swell, and many of the granules in the protoplasm of the leucocytes seem also to become distended into vesicles. The leucocytes of *Necturus* blood are normally of great size and numerous relatively to the red corpuscles. After the action of water, some of them may become even larger than the swollen erythrocytes, and as many as six or more swollen nuclei may be seen in some of them.

Urea in 1 per cent solution in water rapidly lakes the red corpuscles. The nuclei swell and their boundary becomes very distinct, irresistibly

suggesting a membrane. The laked corpuscles are also much swollen. In partially laked corpuscles, what look like radial striæ passing out into the corpuscle from the nucleus may be seen. A similar appearance may be observed in water-laked corpuscles stained with methylene blue, the striæ being blue (Fig. 3). These striæ might possibly be thought to represent fine channels by which the nucleus gets its nutriment from the blood-plasma. This would seem, especially in such large corpuscles, advantageous to the nucleus, whose metabolism is presumably more intense than that of the rest of the corpuscle.

Sapotoxin (2 per cent solution in 0.9 per cent NaCl solution was always used) causes rapid laking with copious formation of crystals of various shapes outside the corpuscles. Some are "knife rest" shape, some almost cubical. The nuclei of the erythrocytes remain intact, are not swollen, and show the normal coarsely granular appearance of the intranuclear network. They stain well with methylene blue. Ghosts can, as a rule, be seen surrounding the nuclei, and their boundary suggests a membrane sometimes frayed. Sometimes an actual gap in the stroma can be seen, the envelope being continued over the gap. Sapotoxin causes most of the leucocytes to disappear, but the large coarsely granular ones are left.

Amyl alcohol produces rapid laking without special feature.

Löffler's methylene blue. — Its action in causing intraglobular crystallization has already been described. It need only be added that immediately after the crystals have appeared in the corpuscle the envelope of the latter may be seen enclosing them. It afterwards disappears from some of the corpuscles. Intraglobular crystallization may take place in corpuscles whose nuclei are not as yet stained in the least. This indicates that the crystallization is caused by the alcohol. Many of the corpuscles are completely laked. A large granular precipitate, the granules of which are stained blue, is thrown down around and on the still unlaked corpuscles. Some of the ghosts seem to disappear entirely, and give rise to the granular precipitate, as heaps of granules may be seen around the deeply stained nuclei, and also in corpuscles which are not yet laked, though globular. The whole extranuclear part of the corpuscle becomes granular, the granules resembling exactly in color and size those outside. Sometimes what looks like an envelope may be seen extending partly around a mass of granules of the same shape and size as a corpuscle. Many of the erythrocytes are seen to become globular, namely those which do not show crystals in their interior and which still retain their hæmoglobin.

Heat-laking. — The temperature necessary for heat-laking seems to be a little less than that required for mammalian blood. In one experiment nearly all the corpuscles (suspended in 0.9 per cent NaCl solution) were laked at 58°, and all at 59° C. At 51° C. there was no laking. A specimen from another *Necturus* laked at 60°, but not below it, *e. g.* not at 59°. It was kept ten minutes at 60°. In neither case did the liquid become quite transparent, even when all the hæmoglobin was discharged. The ghosts were particularly well preserved, and had a granular appearance, as if heat-coagulation of the stroma had taken place. They still retained the oval shape of the intact corpuscle. The nuclei occupied their normal position in the ghosts. Sometimes the ghosts exhibited a "waist" opposite the middle of the nucleus, as if the envelope of the ghost had there become tacked to the nucleus. Methylene blue in 0.9 per cent NaCl solution stained the nuclei well, although the intranuclear network was not quite so distinct as in the intact corpuscles. The envelope and stroma did not stain. But in a specimen heated in *Necturus* serum to 36°, some of the granules in the ghosts stained slightly. The addition of sapotoxin (2 per cent in 0.9 per cent NaCl solution) to the ghosts, after staining with methylene blue, caused much of the stain to come out. Sometimes a portion of the stroma seemed to escape or become dissolved, and the gap could then be seen to be bounded by an envelope (Fig. 17). The addition of Löffler's methylene blue now caused deeper staining of the nuclei, but no other change.

Spontaneous laking. — In four days at room temperature, some of the corpuscles were seen to be laked, and some hæmoglobin crystals were present outside of them. It is not now so easy to obtain intraglobular crystallization by the addition of laking agents, the hæmoglobin being very readily brought out of the corpuscles and then crystallizing outside. Some intraglobular crystallization is, however, caused, *e. g.* by 1 per cent NH₄Cl solution. Intraglobular crystallization may be very easily got, if a little of the blood is allowed to dry partially on a slide without addition of anything. Many of the corpuscles also seem to become laked. The addition of a drop of 0.9 per cent NaCl solution to the partially dried blood causes instant laking of practically all the corpuscles which still retain their hæmoglobin. The nuclei are often surrounded by groups of hæmoglobin crystals. These phenomena are not seen if the blood is mixed with the NaCl solution before it has dried at all.

In blood which had stood nine days, and was long since sponta-

neously laked, a considerable number of round bodies colored with hæmoglobin were seen. They are much smaller than the original erythrocytes, but seem to represent them and their nuclei, as may be shown by adding Löffler's methylene blue, which deeply stains the nuclei as well as the envelope (Fig. 15, 16).

I have already described¹ certain changes produced in mammalian corpuscles fixed with formaldehyde by treating them with ammonia and heating, and in sublimate-fixed corpuscles, by heating them in water or by treating them with H_2S or $(NH_4)_2S$. Still more interesting results have been obtained with *Necturus* corpuscles hardened in formaldehyde, Hayem's solution and osmic acid.

Sublimate-hardened corpuscles.—Addition of H_2S to corpuscles hardened for forty-eight hours in excess of Hayem's solution, and then washed many times with water, causes laking of the corpuscles. The nuclei are not swollen, and the intranuclear network remains unaltered. The ghosts become faint, but do not disappear. Addition of a little NH_3 , after the H_2S has acted, at once causes great swelling of the nuclei, which remain oval in shape and become very indistinct. The nuclei still stain pretty well with Löffler's methylene blue.

Addition of $(NH_4)_2S$ to the washed sublimate corpuscles causes liberation of the hæmoglobin. The nucleus at first remains distinct and surrounded by a black border, which is sometimes divided into small portions of about uniform size by narrow light lines. Possibly this appearance is produced by the beginning of the swelling of the nucleus leading to distention of the structure represented by the dark border. The nucleus now swells greatly, and often appears to burst the corpuscle at one side, so that the ghost assumes the appearance of a "bowler" hat (Fig. 23, 24). This may also be seen in corpuscles which still retain their hæmoglobin or some of it. The phenomenon was first observed after the addition of $(NH_4)_2S$, but it may be at once remarked that NH_3 also produces it, and save in one point to be mentioned presently, it is doubtful whether $(NH_4)_2S$ solution acts in any other way than by reason of the NH_3 in it. The appearances depend on the amount of $(NH_4)_2S$ or NH_3 added. If much is added, the nuclei swell and become exceedingly indistinct, as do the ghosts. All the stages may be traced at different distances from the edge of the slide, if a drop of the reagent is run in under it. The nucleus seems to begin to swell before the rest of the corpuscle

¹ STEWART: Journal of medical research, *loc. cit.*

is affected. If the action of the $(\text{NH}_4)_2\text{S}$ is gradual, the nucleus may swell without rupturing the corpuscle, which swells also to some extent and loses hæmoglobin. The boundary of the nucleus is picked out in black, either as a continuous line or as the interrupted line already described. The black intranuclear network opens out its meshes (Fig. 12, 13) as swelling of the nucleus advances. The hat appearance may not be seen at all at one part of the slide, while all the corpuscles at another part may exhibit it. The addition of Löffler's methylene blue instantly causes deep staining of the nucleus, which at once contracts greatly in size, as does also the whole ghost, the original shape of the corpuscle being resumed. In some of the corpuscles, an envelope stained blue can be made out.

When the sublimate corpuscles are first acted on by NH_3 , and then by Löffler's methylene blue, the envelope is not so well revealed as when $(\text{NH}_4)_2\text{S}$ is used. The best method of all is to add first H_2S , then NH_3 , and then Löffler's methylene blue. To a drop of a suspension of the corpuscles in water, a drop of H_2S solution of equal size is added, and then a much smaller drop of NH_3 . A large amount of NH_3 seems to disintegrate the corpuscles too much, and they disappear. Löffler's methylene blue is now added. A small amount of it stains the nucleus without coloring the rest of the corpuscle or its envelope. A larger quantity causes the nucleus to stain intensely blue. The envelope of the corpuscle and the nuclear membrane are also colored blue (Fig. 10). While the great majority of the nuclei shrink to about normal size on the addition of Löffler's methylene blue, some remain much swollen, and are colored diffusely and much more faintly than the others. It seemed as if there was no envelope around the corpuscles whose nuclei did not shrink. This suggests that the swelling of the nucleus in these cases might have been so great that the envelope was ruptured, and that the osmotic process on which the shrinking of the corpuscles and nucleus depends, could not take place in its absence. As a matter of fact, the shrunken corpuscles exhibit numerous wrinkles all over their surface, the wrinkles appearing more deeply stained than the rest of the corpuscle. In an endeavor to produce heat-fixing of the envelope without destroying the power of the nucleus to expand and to shrink, some of the washed sublimate corpuscles were heated to 60°C . in water for two minutes. The hæmoglobin was not discharged. There was, however, in a few corpuscles, either some swelling of the corpuscle or shrinking of the nucleus, since the latter was separated from the surrounding stroma

by a concentric space. The nuclei swelled on the addition of $(\text{NH}_4)_2\text{S}$ as readily as if the corpuscles had not been heated.

Some corpuscles were heated to 65°C . for fifteen minutes. The hæmoglobin was not discharged. The addition of $(\text{NH}_4)_2\text{S}$ caused swelling of some of the nuclei, but not of all. Addition of H_2S caused the corpuscle to become pale, and its boundary, which was originally black and sharply marked, to become indistinct. H_2S caused no swelling of the nuclei, which, however, either became tinted with the blood-pigment, or showed the tint better when the corpuscles were rendered pale, since they were distinctly yellow. The intranuclear network was still distinct after addition of H_2S . Some corpuscles were less affected by H_2S than others. The addition of NH_3 now caused all the nuclei to swell enormously. The corpuscles also swelled somewhat, but perhaps only passively, owing to the distention of the nucleus, which practically filled the whole corpuscle. The corpuscles did not become spherical, but still retained their oval shape. Addition of Löffler's methylene blue now brought out the envelope and nuclear membrane (Fig. 5, 6, 7, 8, 9).

The preliminary heating of the corpuscles to 65°C . did not seem to make much difference in the result. Presumably, therefore, there is no heat-fixing at this temperature of the portions of the corpuscle which are "mobile" under the influence of the reagents used.

To some of the washed sublimate corpuscles, H_2S , NH_3 , and Löffler's methylene blue were added in succession, with the results just stated, and then sodium taurocholate (in NaCl solution). The blue was partly discharged from all the corpuscles. What looked like a partially separated envelope (Fig. 11) seemed to grow less distinct under the influence of the bile salt, although it did not completely disappear. The taurocholate caused in many of the corpuscles renewed swelling, after the shrinking produced by the methylene blue solution. Addition of NH_3 now caused further swelling, with probable disappearance of some corpuscles.

Formaldehyde-fixed corpuscles.—The corpuscles were fixed in 4 per cent solution of formaldehyde in 0.9 per cent NaCl solution, then washed thoroughly with water, and suspended in water. NH_3 causes the same change of color and of spectrum as in dog's formaldehyde corpuscles.¹ Some of the corpuscles swell somewhat in the cold. On heating to 60°C ., they are considerably swollen and less distinct.

¹ STEWART: Journal of medical research, *loc. cit.*

The nucleus is not swollen, and is as distinct as before. The contrast between the behavior of the formaldehyde and the sublimate corpuscles is very striking, and indicates a marked difference in the structures fixed or in the mode of fixing in the case of the two hardening agents.

Although the Necturus corpuscles look decidedly pale under the microscope, after being heated to 60° in water containing NH_3 , it is not difficult to prove that the laking is mainly apparent. One way of doing this is to filter the corpuscles off from the solution, when it is seen that the blood-pigment is nearly all in the corpuscles. Another method is to cause the corpuscles to shrink, *e. g.*, by the addition of a solution of hydroxylamine hydrochlorate. They become at once smaller, more distinct, and as deeply tinged with blood-pigment as before. Matthes,¹ in connection with the fact discovered by him, that dilute HCl brings the pigment out of sublimate-fixed dog's and frog's corpuscles, mentions an experiment in which he supposes that on standing the ghosts may again take up the hæmoglobin from the liquid. The same possibility suggested itself to Dr. S. Peskind and myself, when we saw formaldehyde-fixed dog's corpuscles apparently lake under the influence of NH_3 and heat, and sublimate-fixed dog's corpuscles apparently lake when heated in water, and yet observed the ghosts in both cases become again tinged with blood-pigment on the addition of hydroxylamine hydrochlorate. We proved clearly² that when this happened the laking was only apparent, the corpuscles being swollen and the blood-pigment, therefore, more dilute in the interior of the corpuscle. Dr. Peskind, while confirming the statement of Matthes that dilute HCl in a certain strength does very easily lake sublimate-fixed mammalian corpuscles, which swell enormously, has since shown that if the swollen corpuscles are caught at a certain point, at which they appear free from hæmoglobin under the microscope, and their suspension in water appears laked to the eye, they can be caused to shrink by hydroxylamine hydrochlorate, when their color returns. At this stage also it can be shown, by filtering off the swollen corpuscles, that they contain most of the blood-pigment. If this critical point be allowed to pass, the corpuscles discharge their hæmoglobin, and their color cannot be restored by hydroxylamine hydrochlorate. Many of them break up entirely. I find that Necturus corpuscles fixed by Hayem's solution are rapidly decolorized by 0.2 per cent HCl, without

¹ MATTHES: Münchener medicinische Wochenschrift, April 29, 1902.

² STEWART: Journal of medical research, *loc. cit.*

appreciable swelling either of the corpuscle or its nucleus. Many of the ghosts disappear if more than the minimum amount of acid needed for laking be used. Some shrinking of the ghosts is caused by hydroxylamine hydrochlorate, but I could not demonstrate any return of the hæmoglobin color.

The *Necturus* formaldehyde corpuscles which have been heated to 65° C. in ammoniacal water, stain deeply with Löffler's methylene blue, the whole corpuscle staining well and the nucleus more deeply. When only a trace of the methylene blue is added, only the nucleus stains, the rest of the corpuscle remaining unstained. The intranuclear network is well seen. There is a great difference between ordinary formaldehyde corpuscles, and those treated in the way described, in the facility with which the extranuclear portion stains.

Formaldehyde corpuscles suspended in water containing NH_3 , and heated several minutes to 60° C., and one minute to boiling, became pale and considerably increased in size. The nucleus was not materially increased in size. The intranuclear network was not so distinct as in ordinary formaldehyde corpuscles, nor did Löffler's methylene blue bring it out so distinctly, although the nucleus, as well as the rest of the corpuscle, stained deeply. In some of the corpuscles, after the methylene blue, a finely serrated or scalloped outline could be seen.

Osmic acid-hardened corpuscles. — The corpuscles were hardened in 1 per cent osmic acid for two days, and then washed many times with water. Sodium taurocholate produces no change in them. NH_3 causes considerable swelling of the corpuscles, which become correspondingly paler and less distinct, though the blood-pigment does not seem to come out. The shape always remains oval. The nucleus swells a little, and the network becomes less distinct. Löffler's methylene blue causes some of the corpuscles to become smaller, and stains the extranuclear portion an intense blue, nearly as deep as that of the nuclei (Fig. 18). Many of the corpuscles do not shrink, but some shrink very greatly, becoming markedly smaller than the normal corpuscle. The border of the nucleus is very prominent, in contrast to that of the corpuscle.

On heating washed osmic acid corpuscles in ammoniacal water to boiling, partial laking seems to take place. The corpuscles are greatly swollen and indistinct. Some of them are fissured. The nuclei are quite distinct, and show the network.

IV. MISCELLANEOUS OBSERVATIONS ON MAMMALIAN CORPUSCLES.

Is the power of NH_4Cl to penetrate the corpuscles dependent upon a toxic influence?— I have shown¹ that NH_4Cl only penetrates perfectly fresh corpuscles, at least in notable amount, after a relatively long "period of resistance." It might be supposed that during this period the NH_4Cl exerted an injurious influence on the envelope of the corpuscle, which changed its natural properties, and that it is only through an injured envelope that NH_4Cl is capable of passing. Experiments V, VI, and VII, were designed to throw light on this point, the idea in all being to see whether the NH_4Cl , when it exists in less than a certain concentration in the serum, is unable to penetrate the corpuscles. If the permeability of the corpuscles for this salt depends upon a poisoning of them by it, this, of course, might be expected to be the case.

In Experiment V the behavior of blood which had stood for forty hours in the cold, after being drawn, was investigated with regard to a mixture of the solutions of NaCl and NH_4Cl employed in the previous experiments, in the proportion of one volume of the NH_4Cl solution to nine volumes of the NaCl solution. In spite of the fact that the conductivity of the NH_4Cl — NaCl mixture is greater than that of the NaCl solution, the conductivity of the blood, after the addition of the mixture, is less than that of the blood to which the NaCl solution has been added. The reason, no doubt, is that NH_4Cl has penetrated the corpuscles. Of course the conductivity of the blood to which the ordinary NH_4Cl solution has been added, is smaller still in comparison with that of the NaCl blood, since the whole of the dissolved substance added to it is capable of entering the corpuscles, while in the mixture only about one-tenth of the dissolved substance added, at most, can do so.

In Experiment VI, perfectly fresh blood was treated with the ordinary NH_4Cl and NaCl solutions, mixtures of the NH_4Cl and NaCl solutions, and solutions of NaCl to which, instead of NH_4Cl solution, the corresponding volume of water had been added. In all cases there is evidence that some of the NH_4Cl penetrates the corpuscles. Since, however, the conductivity of the blood after the addition of NH_4Cl — NaCl mixture is always markedly greater than after the addition of the corresponding NaCl — water mixture, it would appear

¹ STEWART: *Journal of physiology*, 1901, xxvi, p. 476.

that the whole of the NH_4Cl added to the serum never penetrates the corpuscles, or at least does not become bound there in such a form as to prevent it from taking part in the conduction of the current. It seems not improbable that the presence of NaCl in the serum hinders, to some extent, the penetration of the corpuscles by NH_4Cl , or, in other words, exerts a protective influence on the corpuscles, but further observations, including investigation of the sera separated from the mixtures, would be necessary to determine this point.

In Experiment VII, the conductivity of perfectly fresh blood to which quantities of NH_4Cl , ranging from about 1 gm. per 100 c.c. of blood to about 0.02 gm. per 100 c.c. of blood were added in watery solution, was compared with that of the blood to which approximately equal quantities of NaCl were added. It was supposed that if the NH_4Cl penetrates in virtue of some toxic power, there should be some abrupt change in the curve of conductivity at the point where, with increasing concentration of the NH_4Cl , this power first becomes manifest. As is seen in Figure I, in which the conductivities plotted from the results of this experiment are laid off along the vertical, and the number of c.c. of NH_4Cl and NaCl solution added to 15 c.c. of

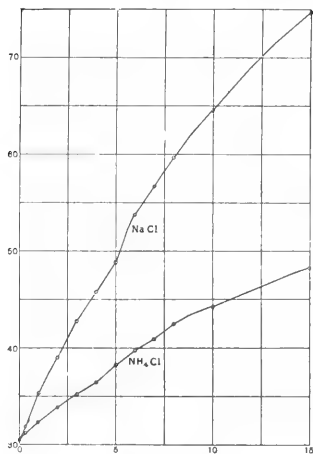

FIGURE I.

blood along the horizontal axis, no such effect can be observed.

A further argument in favor of the view that this is not the explanation of the permeability of the corpuscles for NH_4Cl is found in the observation that this salt, when added in substance to blood, does not produce laking, even when the blood is saturated with it. The laking action of watery solutions of NH_4Cl appears, therefore, to be essentially the same as water-laking.

Effect of amyl alcohol on sublimate-fixed corpuscles.—When dog's corpuscles which have been fixed by Hayem's solution, and thoroughly washed, are suspended in water and treated with amyl alcohol, the blood-pigment after a time is entirely liberated and goes into solution in the water. Mercury is liberated at the same time, and may be detected in the solution of hæmoglobin. Ammonium sulphide throws down a reddish flocculent precipitate insoluble in water, and

evidently containing all the blood-pigment. On washing this precipitate thoroughly with water, although all the pigment is still present, no mercury can be demonstrated in it. Laking by amyl alcohol does not succeed, if the sublimate-hardened corpuscles have been treated with 0.9 per cent NaCl solution for some time before the addition of the amyl alcohol.

SUMMARY OF RESULTS.

Section I. 1. Nucleated blood corpuscles, like non-nucleated, exercise a marked preference for NH_4Cl as compared with NaCl. This is the case even when the blood has been treated with formaldehyde, although the difference is less, especially when the conductivity is measured immediately after mixture. When the mixtures of formaldehyde blood with NH_4Cl and NaCl are allowed to stand, the difference increases continually with the time. Even when the substances were added to blood on which formaldehyde had already acted for twelve days, the difference was very distinct, when the measurements of conductivity were made fifteen hours after mixture. The hardening action of the formaldehyde, accordingly, appears to render the penetration of the NH_4Cl into the corpuscles slower, or their power of binding it less, although it does not abolish their characteristic property of taking up NH_4Cl in preference to NaCl. The preference is equally marked in stale and in fresh blood. In bird's blood, therefore, as in mammalian blood, the preference does not depend on the life of the corpuscles.

2. Saponin produces a notable increase in the conductivity of fowl's blood, as it does in the conductivity of dog's blood. An equal, or even a somewhat greater, increase is produced in both kinds of blood, when saponin is added after the blood has been hardened by formaldehyde. This shows that the increase of conductivity is not dependent on, or associated with, the escape of the hæmoglobin from the corpuscles, since in the formaldehyde blood the hæmoglobin is fixed and the saponin does not cause laking. As in the case of mammalian blood, the increase of conductivity is due to an increase in the permeability of the corpuscles to electrolytes.

3. The conductivity of fowl's blood is diminished by dilution with water to a much smaller extent than would be the case if serum or a solution of electrolytes were correspondingly diluted. This is due to the participation of the electrolytes of the corpuscles

in the conduction of the current after the addition of water. The relative increase of conductivity is quite as well marked in formaldehyde-hardened as in fresh blood. Here, too, there is evidence that the electrolytes of the corpuscles participate in the conduction.

4. Heat-laking of fowl's blood is caused at about the same temperature as that of mammalian blood. The nuclei are not destroyed. The conductivity of fowl's blood may be markedly diminished by heat-laking, unlike that of mammalian blood. The action of saponin on the ghosts of heat-laked fowl's blood causes a marked increase of conductivity, and the action of water a marked relative increase of conductivity, just as in the case of mammalian blood.

Section II. 1. The nucleated colored corpuscles of the blood of the mammalian embryo behave in the same way as the non-nucleated corpuscles of the adult, to most of the laking agents investigated (sapotoxin, sodium taurocholate, amyl alcohol, water, foreign serum). On being heated to 63° – 65° C., they lake like the adult corpuscles, but, unlike them, leave few ghosts behind. Their nuclei also seem to be broken up by heat-laking, unlike those of bird's corpuscles.

2. All the hæmoglobin-containing elements of the red bone marrow of a young mammal were found to behave in the same way as the adult mammalian colored blood corpuscles to the agents investigated (sapotoxin, water, solution of NH_4Cl).

The same was true of the colored corpuscles of the blood of a case of pernicious anæmia to sapotoxin, NH_4Cl solution, urea solution, and heat.

Section III. 1. Intraglobular crystallization of the hæmoglobin of *Necturus* blood is very readily obtained by the action of various hæmolytic agents. The observations on this point show that the hæmoglobin cannot exist in the corpuscles in ordinary aqueous solution.

2. The various laking agents do not cause similar changes in the shape and size of the corpuscles and their nuclei.

3. *Necturus* corpuscles hardened by Hayem's solution are laked by H_2S without swelling of the nucleus. Ammonia causes great swelling of the nucleus.

4. By treating *Necturus* corpuscles hardened by Hayem's solution successively with H_2S , NH_3 , and Löffler's methylene blue, and in other ways, an apparent envelope can be demonstrated.

5. *Necturus* corpuscles fixed by formaldehyde swell under the influence of NH_3 and heat, while the nuclei retain their original size.

The same is true of corpuscles fixed by osmic acid. These facts indicate the existence of differences in the nature and point of attack of the fixation by different hardening agents.

Section IV. The permeability of the colored corpuscles for NH_4Cl does not depend on a toxic effect of the salt on the corpuscle.

EXPERIMENT I.

Effect of water on defibrinated blood, and a sediment of defibrinated blood rich in corpuscles. The blood was obtained from fowls by inserting a cannula into the carotid or jugular. The blood was stirred for a long time (as much as thirty minutes) in order to make sure that it would not clot.

Defibrinated blood.	λ^1	Ratio of λ of undiluted to λ of diluted.	Sediment.	λ	Ratio of λ of undiluted to λ of diluted.
Hen's defibrinated blood	48.28		Sediment from cock's defibrinated blood (after centrifugalization) + 1 vol. water (not laked) + 3 vols. water (laked) + 7 vols. water serum (from clot)		
+ 1 vol. water	27.37	1.76		17.25	
+ 3 vols. water (corpuscles only partially decolorized)	17.84	2.70		10.17	1.69
+ 7 vols. water	112.43	3.88		10.42	1.65
Sediment of the defibrinated blood	36.31			7.84	2.20
After settling a longer time	22.63		91.67		
Serum (from clot)	102.35				

¹ As in all the tables, λ is an abbreviation for $\lambda (5^\circ) \times 10^8$, the conductivity (at $5^\circ \text{C}.$) being expressed in reciprocal ohms $\times 10^8$.

April 13, 1901. At 1.50 P. M. obtained the blood of four fowls by decapitation and defibrinated it. At 2.52 P. M. added to 50 c.c. of the defibrinated blood 15 c.c. of an 8 per cent solution of formaldehyde in NaCl solution. Call the mixture A. On April 14 at 11.40 A. M. added to another quantity of the defibrinated blood one-fifth its volume of the

Time.	Defibrinated blood.	λ	Time.	Formaldehyde blood. A.	λ
April 13 2.44 P. M.	Defibrinated blood	46.43	April 13 4.09 P. M.	A (already brownish)	55.70
3.05 "	Defib. blood + NH_4Cl . ¹		7.45 "	56.58
3.13 "	Not laked, but a little darkened	57.35	7.22 "	A + NH_4Cl .	88.02
3.48 "	56.33	7.24 $\frac{1}{2}$ "	74.34
3.06 "	Defib. blood + NaCl . ¹		7.36 "	After standing 13 hrs. Top	99.80
3.22 "	85.93	7.38 $\frac{1}{2}$ "	A + NaCl .	
3.07 $\frac{1}{2}$ "	Defib. blood + saponin. ¹		6.57 $\frac{1}{2}$ "	91.52
3.15 "	Distinctly darker.		7.11 "	After standing 13 hrs. Top	91.85
3.20 "	Quite dark, but not perfectly laked.		7.56 "	A + saponin.	116.82
3.28 "	Fairly well laked	54.99	7.11 "	Not laked nor darkened	68.33
4.01 "	Completely laked	59.93		After standing 14 hrs. Bottom	68.14
3.33 "	Defib. blood + water. ¹			A + as much of NaCl sol. used in making saponin sol. as was added of the saponin solution	59.09
3.39 "	Not completely laked	21.99		After 38 hrs. Top	93.54
	λ of defibr. blood λ of diluted blood = 2.11.		6.55 $\frac{1}{2}$ "	A + water.	
	Percentage of serum in defibrinated blood, 63.3.		7.04 "	Not laked nor darkened	29.00
				After standing 14 $\frac{1}{2}$ h. Top	28.97
			April 14 10.02 A. M.	A	33.75
				Serum fr'm A (free fr'm blood-pigment)	57.88
			10.37 "	A + NH_4Cl .	94.24
			10.40 "	89.26
				After standing 20 $\frac{1}{2}$ h. Not laked at all	81.31
				Top (free from blood-pigment, but somewhat turbid)	105.19
			10.45 "	A + NaCl .	
			10.48 "	90.21
				After standing 20 $\frac{1}{2}$ h. Top (free from blood-pigment, not turbid)	91.85
			10.55 $\frac{1}{2}$ "	A + saponin.	119.02
			10.58 $\frac{1}{2}$ "	
				After standing 20 $\frac{1}{2}$ h., no laking	67.24
				Top	67.78
				Bottom (separated by centrifuge. Very sticky and thick)	95.30
			11.20 "	A + water.	28.58
			11.24 "	
				After standing 20 $\frac{1}{2}$ hrs., no laking	28.81
				Top	29.72
					35.01

¹ As in all the experiments, "+ NH_4Cl ," "+ NaCl ," without further comment, may be interpreted as meaning that to the blood its own volume of the solution of NH_4Cl or NaCl was added. "+ saponin" means that 0.4 c.c. of the saponin solution was added to 5 c.c. of the blood. "+ water" means that to a given volume of blood two volumes of distilled water were added.

MENT II.

8 per cent formaldehyde solution. Call this mixture B. For the NH_4Cl and NaCl solution, whose effect on the blood was compared, $\lambda =$ respectively 142.41 and 139.30; for the NaCl solution used in making the formaldehyde solution, $\lambda = 139.30$; for the saponin solution, $\lambda = 83.94$; for the NaCl solution used in making saponin solution, $\lambda = 78.97$.

Time.	Defibrinated blood.	λ	Time.	Formaldehyde blood. B.	λ
April 14 10.22 A. M.	Defibrinated blood	45.51	April 14 11.49 A. M.	B	53.26
	Serum from defib. blood	93.54	12.15 P. M.	B + NH_4Cl .	
12.15 P. M.	Defib. blood + NH_4Cl .		12.24 "	Considerably darkened and seems partially laked.	
12.24 "	Little, if at all darkened.			After standing $22\frac{1}{2}$ h.	71.01
12.17 "	After standing $22\frac{1}{2}$ h. ¹	58.41	12.17 "	B + NaCl .	
	Defib. blood + NaCl .		12.19 "	After standing $22\frac{1}{2}$ h	87.41
				B + saponin.	
12.19 "	After standing $22\frac{1}{2}$ h.	83.39	12.25 "	Somewhat darkened but not laked.	
	Defib. blood + saponin.			After standing 24 hrs.	62.44
12.25 "	Quite dark and partially laked.			Very thick, so that some air-bubbles got into U-tube, and this λ is too low.	
	After standing 24 hrs.	69.64	12.01 "	B + water.	
12.21 "	Defib. blood + water.		12.25 "	Darkened but not laked.	
12.25 "	Partially laked.			After standing 25 hrs.	26.30
	After standing 25 hrs.	20.71	April 15 3.12 P. M.	Serum from B	95.30
			3.20 "	B	53.37
			3.34 $\frac{1}{2}$ "	B + NH_4Cl .	
			3.37 "	88.02
				After standing 20 hrs.	79.22
			3.42 "	B + NaCl .	
			3.44 $\frac{1}{2}$ "	89.89
				After standing 20 hrs.	91.20
			3.51 "	B + saponin.	
			3.54 "	65.84
				After standing 20 hrs.	67.96
			4.00 "	B + same amount of NaCl sol. used in making saponin sol. as was added of saponin solution	54.05
				After standing 20 hrs.	56.46
			4.07 "	B + water.	
			4.12 "	28.13

¹ Unless otherwise mentioned, the blood-mixtures were kept, for all periods exceeding a few hours, in a cold room whose temperature varied from 5° C. or less to about 8° C.

EXPERIMENT III.

April 19, 1901. Fowl's blood obtained by decapitation at 2.30 P. M., and defibrinated. At 7.20 P. M. added to 50 c.c. of the blood 25 c.c. of a 4 per cent formaldehyde solution in NaCl solution. Call the mixture A.

For the NH_4Cl solution $\lambda = 142.41$; for the NaCl solution $\lambda = 139.30$.

For the saponin solution $\lambda = 137.03$; for the formaldehyde solution $\lambda = 112.17$.

Time.	Defibrinated blood.	λ	Time.	Formaldehyde blood. A.	λ
April 19 7.43 P. M.	Defibrinated blood	49.32	April 19 7.50 P. M.	A	68.70
April 20 2.23 P. M.	Serum from defib. blood (only very faint trace of Hb in it)	92.18	April 20 2.12 P. M.	Serum from A (only the faintest trace of blood-pigment in it)	101.40
April 21 8.55 A. M.	Defibrinated blood	49.32	April 21 8.42 A. M.	A	70.03
9.04 "	4 c.c. defib. blood + 4 c.c. NH_4Cl .		9.04 "	6 c.c. of A + 4 c.c. NH_4Cl	
9.38 "	Not laked but darker than defib. blood + NaCl	63.37	9.55 "	88.02
11.20 "	62.90	11.45 "	No laking	85.35
	After standing 26 hours more	66.71	1.34 P. M.	85.07
1.42 P. M.	To 4 c.c. of the mixture of defib. blood and NH_4Cl added 1 c.c. of the formaldehyde solution.			After standing 21 hrs. longer	82.30
				Top	102.63
			9.08 A. M.	6 c.c. of A + 4 c.c. NaCl	
1.57 "	This mixture	71.61	10.03 "	94.94
	After standing 24 hrs.	65.84	11.35 "	91.20
9.08 A. M.	4 c.c. defibrinated blood + 4 c.c. NaCl.			After standing 23 hrs. longer	92.52
9.44 "	88.33		Top	114.71
11.29 "	87.72	9.22 A. M.	6 c.c. of A + 0.4 c.c. of saponin solution.	
	After standing 27 hours more	86.22	10.13 "	80.99
1.50 P. M.	To 4 c.c. of the mixture of defib. blood and NaCl added 1 c.c. of the formaldehyde solution.		11.55 "	79.97
				After standing 24 hrs. longer	80.22
				Top	100.80
2.06 "	This mixture	93.54	10.39 "	6 c.c. of A + 0.4 c.c. of the NaCl solution used in making the saponin solution.	
	After standing 24 hrs.	87.11	11.12 "	71.41
9.22 A. M.	4 c.c. defibrinated blood + 0.4 c.c. saponin.			After standing 26 hrs. longer.	
9.26 "	Well laked.			Top	101.00
10.21 "	69.26	9.13 "	6 c.c. of A + 8 c.c. of water.	
12.05 P. M.	69.26			

EXPERIMENT III.—(continued).

Time.	Defibrinated blood.	λ	Time.	Formaldehyde blood. A.	λ
10.39 A. M.	4 c.c. defib. blood + 0.4 c.c. of the NaCl solution used in making the saponin solution.		10.48 " After standing 26 hrs. longer Top	39.42 39.12 45.27
11.05 "	56.46	May 1 3.35 P. M.	A	71.21
12.10 P. M.	4 c.c. defib. blood + 0.4 c.c. saponin.		3.55 "	6 c.c. of A + 0.4 c.c. of saponin solution.	
12.25 "	68.33	4.00 "	80.47
2.34 "	To 4.4 c.c. of the mixture of defib. blood and saponin solution added 2 c.c. of the formaldehyde solution.		7.02 "	82.84
2.55 "	This mixture	79.22	4.05 "	6 c.c. of A + 0.4 c.c. of the NaCl solution used in making the saponin solution.	
9.13 A. M.	4 c.c. defib. blood + 8 c.c. water.		4.10 "	75.00
10.57 " After standing 28 hrs. Top	21.87 22.49 31.61	4.22 "	2 c.c. of A + 1.33 c.c. NH_4Cl . After standing 15 hrs. 2 c.c. of A + 1.33 c.c. NaCl. After standing 15 hrs.	88.33 95.66
2.17 P. M.	To 6 c.c. of the mixture of defib. blood and water added 1 c.c. of the formaldehyde solution.				
2.46 "	This mixture	38.29			
	After standing 24 hrs.	31.33			
	Top	39.73			

EXPERIMENT IV.

April 22, 1901. Heat-laked fowl's blood. The blood was the same as that used in Experiment III. The solutions of NH_4Cl , NaCl , and saponin were also the same.

Time.	Heat-laked fowl's blood.	λ
6.24 P. M.	Defibrinated fowl's blood	49.41
6.00 "	Heated some of the blood for fifteen minutes to 60° to 64° C. Becomes dark and laked. Is thicker than laked dog's blood.	
6.35 "	The heat-laked blood	34.07
7.31 "	Heat-laked blood + NH_4Cl .	
7.52 "	After standing 14 hours	78.48 79.22
7.33 "	Heat-laked blood + NaCl .	
7.58 "	After standing 14 hours	79.72 78.97
7.35 "	Heat-laked blood + saponin.	
8.05 "	66.19
7.37 "	Heat-laked blood + water.	
8.15 "	27.86
6.50 "	Heated another specimen of the blood to 60° C. It darkens and lakes, but less readily than at 64° . It is also thick. It begins to darken a little above 50° .	
7.20 "	This specimen of heat-laked blood	29.75

EXPERIMENT V.

Defibrinated blood obtained from a bitch forty hours before, and kept in cold.

Time.		λ
3.00 P. M.	The defibrinated blood	26.32
	NH ₄ Cl solution	136.29
	NaCl solution	130.67
	NH ₄ Cl-NaCl mixture (containing 1 vol. of NH ₄ Cl solution to 9 vols. of NaCl solution	131.35
3.06 "	To 5 c.c. blood added 5 c.c. of the NH ₄ Cl-NaCl mixture.	
3.18 "	71.01
4.31 "	Is not noticeably darkened or laked	69.83
	After standing 22 hours longer	65.33
3.07 "	To 5 c.c. blood added 5 c.c. of the NaCl solution.	
3.25 "	72.22
4.40 "	71.61
	After standing 22 hours longer	69.26
3.36 "	To 5 c.c. blood added 5 c.c. of the NH ₄ Cl solution.	
3.48 "	59.65
4.23 "	Now much darkened	42.75
	After standing 22 hours longer	44.55

EXPERIMENT VI.

Fresh defibrinated blood obtained from a dog one hour before the beginning of the experiment.

Time.		λ
	The defibrinated blood	20.63
	NH ₄ Cl solution	136.29
	NaCl solution	130.67
	NH ₄ Cl-NaCl mixture containing 1 volume of the NH ₄ Cl solution to 9 volumes of the NaCl solution (Mixture A)	131.35
	NH ₄ Cl-NaCl mixture containing equal volumes of NH ₄ Cl and NaCl solutions (Mixture B)	131.35
	A mixture containing 9 volumes of the NaCl solution to 1 volume of water (Mixture A')	118.46
	A mixture containing equal volumes of the NaCl solution and of water (Mixture B')	67.96
3.36 P. M.	To 10 c.c. of blood added 10 c.c. of Mixture B.	
4.36 "	Slightly darkened	57.88
	After 24 hours a little Hb in solution in serum	57.61
4.18 "	To 10 c.c. blood added 10 c.c. of Mixture B'.	
4.59 "	After 24 hours serum distinctly red, although not nearly so much Hb in it as in the serum of the blood to which its own volume of the NH ₄ Cl solution was added	40.56
		42.60
3.37 "	To 10 c.c. blood added 10 c.c. of the NH ₄ Cl solution.	
4.44 "	Darkened and laked in a few minutes	35.31
	After 24 hours	36.01
3.39 "	To 10 c.c. blood added 10 c.c. of Mixture A.	
4.50 "	After 24 hours serum not red	65.17
		65.84
5.11 "	To 10 c.c. blood added 10 c.c. of Mixture A'.	
5.27 "	Not at all darkened	61.38
	After 24 hours no Hb in serum	63.06
3.35 "	To 10 c.c. blood added 10 c.c. of the NaCl solution.	
4.30 "	After 24 hours no Hb in the serum	66.36
		67.78

EXPERIMENT VII.

Defibrinated blood obtained from a dog forty-two minutes before the beginning of the observations. For the fresh defibrinated blood, $\lambda = 30.47$; thirty hours later, 29.82, and fifty-three hours after it was drawn, 30.32. For the serum obtained from clot, $\lambda = 98.97$. Percentage of serum in defibrinated blood, 55.4. For the NH_4Cl solution, $\lambda = 136.29$ for the NaCl solution, $\lambda = 130.67$.

Quantity of blood in c.c.	C.c. of NaCl or NH_4Cl solution added.	Interval between mixture and measurement of λ of NH_4Cl mixt.		λ of NH_4Cl mixture.	Interval between mixture and measurement of λ of NaCl mixt.		λ of NaCl mixture.
		Hrs.	Min.		Hrs.	Min.	
50	1	..	57	31.14	1	4	31.89
..	..	25	..	30.99	25	..	31.93
15	1	1	0	32.33	..	43	35.36
..	..	29	..	32.42	29	..	34.58
15	2	1	8	33.89	1	6	39.00
..	..	28	30	34.40	28	30	38.94
15	3	1	46	35.16	1	28	42.75
..	..	28	30	36.32	28	30	42.82
15	4	1	51	36.47	1	48	45.76
..	..	28	..	37.89	28	..	46.77
15	5	2	12	38.23	1	55	48.94
..	..	26	30	39.73	26	30	50.60
15	6	1	2	39.80	..	58	53.71
15	7	1	15	40.95	1	12	56.58
15	8	1	29	42.53	1	23	59.65
15	10	1	40	44.32	1	34	64.52
10	10	1	33	48.29	1	34	74.78

EXPLANATION OF FIGURES.¹

FIGS. 1 to 28 were drawn with Leitz Oc. IV, Obj. Pantachromatic 3 mm. Tube not drawn out. All except 1-4 were drawn in outline with the camera lucida. For 5-19 the paper was at the level of the stage; for 20-28 at the level of the foot of the microscope. In reproduction 5-28 are reduced to about $\frac{1}{2}$; 1-4 to $\frac{3}{8}$.

1. Intraglobular crystallization produced by a watery solution of methylene blue.
2. Hæmoglobin crystals formed outside the corpuscles after addition of a 2 per cent sapotoxin solution in 0.9 per cent NaCl solution.
3. A water-laked corpuscle stained with methylene blue, showing fine radial striæ extending out from the nucleus.
4. Intraglobular crystallization produced by 2 per cent solution of taurocholate of sodium in 0.9 per cent NaCl solution. The envelope of the corpuscle has apparently disappeared between the hæmoglobin crystals, but dark streaks due to the wrinkling of the envelope are seen over the crystals, either because the wrinkled envelope still persists in this situation, or because the wrinkling present during the formation of the crystals caused them to become correspondingly grooved.
5. A corpuscle fixed by Hayem's solution, then thoroughly washed with water, then heated in suspension in water to 65° C., then treated with H₂S, then with NH₃, and then with Löffler's methylene blue.
6. A corpuscle treated in the same way as in 5. It shows nuclear membrane and also envelope of the corpuscle.
7. A corpuscle subjected to the same treatment, showing envelope of corpuscle and a gap from which the nucleus has escaped.
8. A corpuscle, treated in the same way, showing rupture of the envelope by swelling of the nucleus.
9. A corpuscle, treated in the same way, showing the envelope partly detached.
10. A corpuscle fixed by Hayem's solution, washed, treated with H₂S, then NH₃, then Löffler's methylene blue. It shows a bulging as if the envelope was tacked at one point to the nucleus.
11. A corpuscle fixed by Hayem's solution, washed, then treated with H₂S, NH₃, and Löffler's methylene blue, and then with 2 per cent solution of sodium taurocholate in 0.9 per cent NaCl solution, and then again with NH₃. The nucleus fills the whole swollen corpuscle, and therefore is faintly stained. At one side the nuclear membrane and the envelope of the corpuscle seem to be detached, the former being the more deeply stained.
12. A Hayem-fixed corpuscle washed with water and then treated with NH₃. It shows great swelling of the nucleus and opening out of the meshes of the intranuclear network. The corpuscle preserves its elongated shape, and the nucleus does not encroach on the poles.
13. A corpuscle treated in the same way as in 12. It is more globular than the one shown in 12; the intranuclear network is more strongly marked, and nearly the whole corpuscle, including the poles, is occupied by the nucleus.
14. A washed Hayem-fixed corpuscle treated with NH₃ and then with Löffler's methylene blue. The latter caused the swollen nucleus to shrink. At one side the envelope seems to be tacked down to the nucleus.

¹ I am indebted to my pupil Mr. Samuel S. Berger for drawing Figs. 1 to 4.

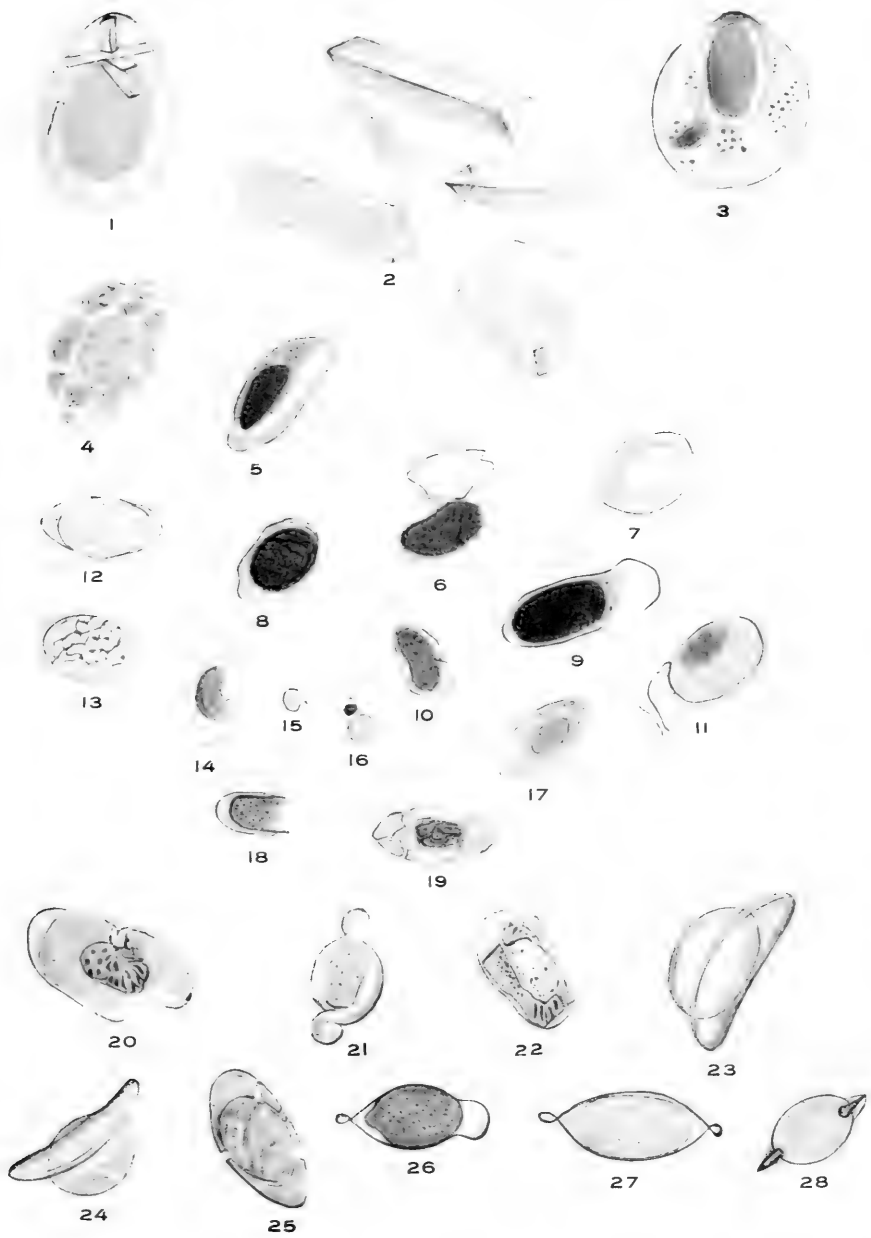

EXPLANATION OF FIGURES — (*continued*).

15. A very small body with the characters of a colored corpuscle, left after spontaneous laking. Stained with Löffler's methylene blue. The envelope seems to be ruptured at one side, and the nucleus has escaped.

16. A small corpuscle after spontaneous laking, stained with Löffler's methylene blue. What seems to be its nucleus lies beside it.

17. Fresh blood-corpuscle suspended in 0.9 per cent NaCl solution and heated to 60° C. Then treated with methylene blue in 0.9 per cent NaCl solution, and then with 2 per cent solution of sapotoxin in 0.9 per cent NaCl solution. A gap is seen near one end, which is bounded by the envelope.

18. A portion of a corpuscle fixed by osmic acid, washed with water, then treated with NH_3 , then heated and then treated with Löffler's methylene blue. Where the corpuscle is fractured the nuclear membrane seems to protrude. It is stained a deep blue.

19. Fresh corpuscle suspended in 0.9 per cent NaCl solution, treated with Löffler's methylene blue. Intraglobular crystallization of the hæmoglobin has taken place. At two points on opposite sides of the nucleus there is no hæmoglobin, the pigment having apparently been dissolved out before it could crystallize. Here what appears to be the stroma is seen bounded by the envelope.

20. Fresh corpuscle treated with the sodium taurocholate in salt solution. The hæmoglobin is still retained in the greater part of the corpuscle.

21. A fresh corpuscle treated as in 20. The corpuscle is twisted at both poles, where the outline of the envelope can be traced, forming a loop.

22. A fresh corpuscle treated in the same way. The hæmoglobin remains in the whole corpuscle except at the poles.

23. A washed Hayem-fixed corpuscle treated with $(\text{NH}_4)_2\text{S}$. (NH_3 has the same effect.) The nucleus has swollen enormously and apparently burst through one side of the corpuscle, which has assumed the form of a hat.

24. A corpuscle treated as in 23. The nucleus has burst through both sides of the corpuscle, though the greater part of it protrudes through one side.

25. A corpuscle treated as in 23, seen on the flat. The swelling of the nucleus seems to have caused fissures in the corpuscle. The same thing is seen when NH_3 is used instead of $(\text{NH}_4)_2\text{S}$. The envelope of the corpuscle is not usually visible across the fissures, perhaps because it is dissolved by the NH_3 .

26. Fresh corpuscle stained with a solution of methylene blue in 0.9 per cent NaCl solution, then treated with Na taurocholate. The hæmoglobin is completely discharged. The ghost is twisted at both poles. The nucleus is not excessively swollen and is therefore pretty deeply stained.

27. A fresh corpuscle treated as in 26. The nucleus is more swollen than in 26 and more faintly stained.

28. Fresh corpuscle treated in same way. The nucleus fills the whole corpuscle except at the poles, each of which is occupied by a hæmoglobin crystal.

THE EFFECT OF DIMINISHED EXCRETION OF SODIUM CHLORIDE ON THE CONSTITUENTS OF THE URINE.

By R. A. HATCHER AND TORALD SOLLMANN.

[From the Pharmacological Laboratory of Medical Department of Western Reserve University, Cleveland, Ohio.]

CONTENTS.

	Page
I. Introductory	139
II. Clinical histories	139
III. Methods of analysis	140
IV. Calculation of results	141
V. Results	141
VI. Discussion of results	145
VII. Appendix: Tables and curves	146

I. INTRODUCTORY.

IT is well known that the chloride content of the urine is notably diminished in febrile diseases. This alteration in the composition of the urine should be accompanied by changes in the composition of the other urinary constituents, if the physical theories of urine formation hold true. These changes, if they occur, would probably throw some light upon the mechanism of chloride-retention. A minute study of the composition of chloride-free urines seemed therefore desirable. These considerations led us to undertake the research recorded in this paper. The courtesy of Dr. L. W. Ladd enabled us to work on two cases of typhoid fever at Lakeside Hospital, Cleveland. The urines of these patients were almost devoid of chlorides, and were therefore well adapted to our purpose. The main results agree so well in both cases, that we may consider them as typical.

II. ABSTRACT OF THE CLINICAL HISTORIES OF THE CASES.

Frank Nachtigall, Med. No. 1937. Admitted July 5, 1901, with diagnosis of typhoid fever. Widal test is positive. Temperature 105° F. A milk diet is begun on July 6. The patient is sponged with water of 90° F. whenever the fever rises above 102° F. Small doses of strychnine are

also prescribed. The urine contains a faint trace of albumin. On July 12 the diarrhœa has ceased. The temperature varies between 102° and 104° . On July 17 the temperature has fallen considerably, and on July 25 it has returned to normal. The patient is discharged as well on Aug. 9.

James Boles, Med. No. 2099. Age 29. Admitted Aug. 19, 1901, with diagnosis of typhoid fever, the onset of the disease being given as Aug. 12. The Widal test is positive on Aug. 20. Milk diet was begun on Aug. 19, also sponging and strychnine. Tub baths are begun on Aug. 20. The temperature to Aug. 25 ranges between 102° and 104° F. On Aug. 29 the fever begins to fall, and continues to fall until Sept. 3, when it rises again, and reaches 103° F. It remains about this until Sept. 10. From this date until the 20th it varies between 98.5° and 101.5° . On Sept. 23 it is practically normal. On Sept. 6 a femoral phlebitis set in which subsided on Sept. 19. On Oct. 4 the patient suffered a relapse. He was discharged as well on Oct. 30.

III. METHODS OF ANALYSIS.

The urines were collected from 7 A. M. to 7 A. M. in glass-stoppered 2-litre bottles, which were brought to the laboratory at 10 A. M. In the first case (*Nachtigall*) the *quantity* was measured at the hospital. As we found reason to doubt the accuracy of these measurements, we directed in the second case (*Boles*) that the level of the urine be marked on a slip of paper gummed to the side of the bottle. The urine quantity could in this way be measured by ourselves. The *freezing-points* were determined by the Beckmann apparatus, the mean of three observations being taken. All the other determinations were made in duplicate. The *chlorides* were estimated in 10 c.c. of urine by Salkowski's modification of Mohr's method. The *phosphates* were determined volumetrically with uranium, in 50 c.c. of urine, using cochineal as indicator. The total *sulphates* were estimated gravimetrically, by boiling 50 c.c. of urine for five minutes with 10 c.c. of HCl, and precipitating with barium chloride. The *total nitrogen* was determined by the Kjeldahl method, using 4 c.c. of urine. For the *total solids*, 10 c.c. of urine were evaporated and dried at 110° C. for forty-eight hours. The residue was incinerated for *ash*. The difference was calculated as *organic residuc*. There is reason to suppose that there was considerable loss of ammonia during the drying and incineration. Indeed, it sometimes happened that the nitrogen was greater than the organic matter, and the sodium chloride

greater than the ash. We therefore place but very little value on the data of solids, ash, and organic matter.

The analyses and calculations were made almost exclusively by R. A. Hatcher.

IV. CALCULATION OF THE RESULTS.

The salts were calculated as NaCl, Na₂SO₄ and P₂O₅.

Ct = the *total concentration*, was obtained by dividing the depression of the freezing point by 1.89.

Cu = the *concentration of urea*, was computed by calculating the nitrogen (grams per litre) as urea (multiplying by 2.14) and dividing by the molecular weight of urea (60).

Ccl = the *concentration of the chlorides*, was similarly computed by dividing the grams of NaCl per litre by the molecular weight and multiplying with (1+*a*). *a*, the degree of dissociation, was deduced from the weight of the ash.

The *concentration of the sulphates* was calculated by an analogous formula.

$\Delta \times c.c.$ and $C \times c.c.$, the *daily molecules*, were obtained by multiplying Δ or *Ct* by the daily quantity of urine, expressed in c.c.

δ = the *metabolic molecules*, (Claude and Balthazard) are computed by multiplying the NaCl per cent by 0.61 and subtracting the product from Δ . The factor represents the depression of freezing-point due to the non-chloride molecules, on the assumption that the dissociation of the chlorides is that of a 1 per cent NaCl solution.

$\frac{\Delta}{\text{NaCl}\%}$ represents the ratio of total molecules to chloride molecules; $\frac{\Delta}{\delta}$, that of total molecules to "metabolic" molecules.

V. RESULTS.

We will present our results in condensed form. These may be controlled by the table of averages (Table I), and more exactly by the detailed tables, and by the curves from the case of Boles given in the appendix. The principle changes in the urine are to be seen in its quantity, and in the sodium chloride, total molecules, and $\frac{\Delta}{\text{NaCl}\%}$, or corresponding factors. The variations are smaller in the case of nitrogen, and least with SO₄ and P₂O₅. It could also be seen that with the nitrogen the daily variations are less than the variations in

percentage, whereas with SO_4 and P_2O_5 the percentage was the more constant.

As was to be expected, the changes in composition are not rigorously uniform under similar conditions. They exist rather as tendencies which may be obscured on individual days. Whilst they may be recognized by a careful study of the daily figures, they are seen more strikingly in averages of typical days, the accidental variations being in this manner largely neutralized.

These averages are presented in the table shown on pages 143-4.

1. **Salt starvation.** — (*Period of pure milk regime.*) — This lessens in the first place the quantity of chlorides, and raises the factor $\frac{\Delta}{\text{NaCl}}$ very greatly — to 72.3. The quantity of the urine is less than during the period of convalescence; Δ is also somewhat lower: The daily molecules are therefore somewhat diminished. The daily output of nitrogen is lessened, but its percentage is increased. This increased concentration of nitrogen causes the Δ to be near to normal, notwithstanding the low concentration in salts. The factor $\frac{\Delta}{\delta}$ is of course abnormally low. The other urinary salts, SO_4 and P_2O_5 , are slightly lessened in concentration, and particularly in daily quantity.

The composition of the urine under the influence of salt withdrawal, or retention, appears to be regulated mainly by three factors: — viz.

1. A tendency to maintain Δ near 1.0 to 1.5.

2. A tendency to maintain the normal chloride content of the body.

3. A tendency to excrete a definite amount of nitrogen.

2. **Salt administration.** — This causes in general the reverse changes to salt withdrawal. The sodium chloride rises greatly, and may reach 16.9 per litre, or 25.6 gm. per day. $\frac{\Delta}{\text{NaCl}}$ is greatly depressed, to a minimum of 1.25. The quantity of urine is increased, and its concentration rises considerably; the daily molecules therefore show a great increase. The concentration in nitrogen is diminished; but this diminution is slight, and in the case of Boles the percentage is even increased a trifle. The daily excretion of nitrogen is considerably increased — the maximum increase being from 10.5 to 15.2 (Nachtigall), and from 12.6 to 17.8 (Boles); the average increase is from 10.46 to 13.67 (N.), and from 12.6 to 14.47 (B.). $\frac{\Delta}{\delta}$ is of course considerably

TABLE I.
AVERAGES OF PERIODS.

The first figures represent the averages, those in parentheses the extremes.

		PERIOD OF CONVALESCENCE (SOFT DIET). Nachtigall, July 27, 28, and 29. Boles, Sept. 4 to 21.	
		Per litre.	Per day.
Quantity	{ N. } B.		838 (591-1124) 1280 (900-1980)
Δ	{ N. } B.	1.324 (0.976-1.787) 1.043 (0.711-1.488)	
$\Delta \times c.c.$	{ N. } B.		1179.86 (887.3-1596.1) 1241.3 (876.6-1597.4)
$\frac{\Delta}{\delta}$	{ N. } B.	1.31 (1.11-1.61) 1.41 (1.27-1.70)	
NaCl	{ N. } B.	4.4 (3.0-6.1) 4.76 (3.2-8.3)	5.91 (3.65-9.50)
Na ₂ SO ₄	{ N. } B.	2.32 (1.41-3.36) 2.65 (2.56-2.74) ¹	3.0 (2.47-3.60) ¹
P ₂ O ₅	{ N. } B.	1.75 (1.07-3.13) 1.91 (1.75-2.05) ¹	2.14 (1.84-2.59) ¹
N.	{ N. } B.	11.41 (6.87-18.16) 8.72 (4.69-11.55)	10.57 (7.42-15.17)
$\frac{\Delta}{NaCl}$	{ N. } B.	4.03 (2.53-5.96) 2.43 (1.69-2.89)	
		PERIOD OF SALT STARVATION. Nachtigall, July 11 to 19. Boles, Aug. 22 to 23.	
		Per litre.	Per day.
Quantity	{ N. } B.		972 (650-1597) 802 (680-925)
Δ	{ N. } B.	1.163 (0.859-1.446) 0.994 (0.991-0.997)	
$\Delta \times c.c.$	{ N. } B.		1094.6 (804.8-1428.5) 798.4 (673.8-922.2)
$\frac{\Delta}{\delta}$	{ N. } B.	1.02 (1.00-1.04) 1.045 (1.03-1.06)	
NaCl	{ N. } B.	0.5 (0.2-1.0) 0.77 (0.55-0.9)	0.49 (0.130-0.857) 0.56 (0.51-0.61)
Na ₂ SO ₄	{ N. } B.	2.51 (2.10-2.97) 2.19 (2.18-2.21)	1.72 (1.21-2.37) 1.76 (1.50-2.02)
P ₂ O ₅	{ N. } B.	1.95 (1.20-3.00) 1.28 (1.06-1.51)	1.82 (1.07-2.65) 1.06 (0.72-1.40)
N.	{ N. } B.	12.63 (9.48-16.10) 12.12 (12.07-12.18)	12.13 (8.52-16.92) 9.67 (8.28-11.15)
$\frac{\Delta}{NaCl}$	{ N. } B.	32.15 (14.24-72.3) 14.56 (11.01-18.12)	

¹ 13, 14, and 21 only.

TABLE I—(continued).

		PERIOD OF SALT ADMINISTRATION.	
		Nachtigall, July 22 to 23. Boles, Aug. 25, 26, 27, and 30.	
		Per litre.	Per day.
Quantity	{ N. B.		1335 (1183-1488) 1154 (960-1425)
Δ	{ N. B.	1.955 (1.609-2.301) 1.368 (1.220-1.498)	
$\Delta \times$ c.c.	{ N. B.		2655.3 (1903.4-3407.3) 1342.4 (1150.6-1767.6)
Δ	{ N. B.	1.63 (1.45-1.81) 1.30 (1.14-1.55)	
δ	{ N. B.	12.5 (8.1-16.9) 5.0 (2.9-8.7)	17.36 (9.58-25.58) 5.77 (3.04-10.26)
NaCl	{ N. B.	2.86 (2.75-2.97) 3.26 (2.46-4.74)	2.12 (1.80-2.44) 3.77 (2.49-5.92) ¹
Na_2SO_4	{ N. B.	2.82 (2.04-3.60) 1.35 (1.13-1.72)	3.64 (3.03-4.26) 1.79 (1.08-2.69)
P_2O_5	{ N. B.	10.46 (8.01-12.91) 12.6 (11.37-13.37)	13.67 (12.13-15.22) 14.47 (12.63-17.81)
N.	{ N. B.	1.68 (1.40-1.97) 3.18 (1.72-4.82)	
$\frac{\Delta}{\text{NaCl}}$	{ N. B.		

¹ 25, 26, and 30 only.

increased (to a maximum of 1.94). SO_4 and P_2O_5 are increased, both in concentration, and more especially per day.

The height of all these changes is reached on the second day, the salt being given for one or two days. On the third day there is a considerable fall, and the normal is reached on the fifth or sixth day.

The daily quantity of urine pursues quite uniformly a rather peculiar course: It is increased on the first day, reaches its maximum on the second, falls *below* normal on the third, is again high on the fourth, and continues high for some time.

3. **Effects of variations in the quantity of urine.**—The total concentration, as well as that of the individual constituents, tends to be roughly inverse to the quantity of the urine. During the salt starvation, the main effect falls upon the urea. The daily quantity of the constituents tends to vary directly as the diuresis.

4. **The concentration of the individual salts have little relation to each other.**— SO_4 follows the urea, but the increase of SO_4 during the salt starvation is not as great as the increase of nitrogen. P_2O_5 pursues its own course, being probably largely dependent upon the

food, whilst its quantity is not large enough to be influenced by the Δ , as is that of urea.

5. The height of the fever appears to have but little influence upon the urine.

VI. DISCUSSION OF RESULTS.

Our results show that the disappearance of the chlorides from the urine does not lead to any very large changes in the other urinary constituents — not sufficient at least to alter the physical properties of this fluid. Nor does the administration of sodium chloride produce such changes. The bearing which these facts have upon the theory of urine secretion becomes evident when they are considered in connection with other data, as will be done in the next paper.

We would, however, draw attention to several practical considerations which are suggested by our results. The first relates to diagnosis, the second to therapeutics.

1. According to the school of v. Koranyi, heart disease can be diagnosed from a high $\frac{\Delta}{\text{NaCl}}$ joined with low $\Delta \times \text{c.c.}$ Our results show that the same change results, in at least an equal degree, from milk diet. Unless due value is given to this fact, a mistake in diagnosis may easily occur.

2. The addition of sodium chloride to a milk diet results in a greater excretion of urine and of metabolites. The latter are at the same time diluted. These effects seem to us desirable, especially in fevers. The retention of chlorides shows further that the body requires a certain amount of sodium chloride, which is not supplied by the insufficient quantity of this substance contained in the milk. For these reasons the addition of sodium chloride to a milk diet appears commendable. The salt may be added directly to the milk without inconvenience. It should be distributed so that about fifteen grams are taken per day.

VII. AP

TABLE

COMPOSITION OF

I. *Nachtigall*. Milk diet from July 6th to 26th.

Date. 1901.	Quan- tity. (c.c.)	Grams per litre.						
		NaCl.	Na ₂ SO ₄ .	P ₂ O ₅ .	N.	Total solids.	Ash.	Organic residue.
July 11	650	0.2	2.305	1.65	16.10	22.42	3.42	19.00
" 13	1035	0.2	2.65	1.46	12.67	14.75	4.21	10.54
" 14	887	0.3	2.52	1.40	11.41	16.51	4.34	12.17
" 15	1597	0.5	2.07	1.20	9.48	15.85	3.80	12.10
" 16	828	0.3	2.10	3.00	10.29	13.10	5.85	7.25
" 17	769	0.8	2.55	2.77	11.93	17.10	6.00	11.10
" 18	1153	0.7	2.97	2.30	15.54	16.35	6.15	10.20
The patient received soft diet on the 19th, but returned to milk diet on the 20th.								
July 19	857	1.0	2.94	1.85	13.65	16.05	6.27	9.78
Three slices of bread and one egg on 21st.								
" 21	1479	2.8	2.24	2.15	10.57	15.90	7.15	8.75
120 gms. of NaCl were given during the two days, beginning with 7 A. M. of the 21st and ending with 7 A. M. of the 23d.								
July 22	1183	8.1	2.97	3.60	12.91	28.45	14.07	14.38
" 23	1488	16.9	2.75	2.04	8.01	27.33	20.81	6.52
Sodium chloride stopped.								
" 24	532	14.6	2.48	2.76	10.81	31.80	19.85	11.95
" 25	1035	7.3	2.49	3.45	13.23	26.01	11.38	14.63
Soft diet begun on 26th.								
" 26	1183	4.4	3.88	5.10	17.81	28.46	12.92	15.54
" 27	591	3.0	3.36	3.13	18.16	26.60	10.40	16.20
" 28	798	3.1	1.93	1.27	10.29	13.18	6.50	6.68
" 29	1124	5.6	2.59	1.55	10.32	17.75	9.19	8.56
Aug. 9	21	6.1	1.41	1.07	6.87	14.83	9.53	5.30

¹ Not known, but high.

PENDIX.

II.

THE URINES.

II. **Boles.** Milk diet from August 19th till September 4th.

Date. 1901.	Quantity. (c.c.)	Grams per litre.						
		NaCl.	Na ₂ SO ₄ .	P ₂ O ₅ .	N.	Total solids.	Ash.	Organic residue.
Aug. 22	680	0.90	2.206	1.06	12.18	16.89	1.32	15.57
" 23	925	0.55	2.182	1.51	12.07	15.50	1.84	13.66
" "	Sodium chloride, 30 gms. in two days (24th and 25th).							
" 24	1080	0.95	2.460	1.37	12.53	14.02	1.79	12.23
" 25	1425	3.70	4.736	1.14	12.50	13.62	3.26	9.36
" "	Sodium chloride discontinued.							
" 26	960	4.70	2.582	1.13	13.16	17.71	4.18	13.53
" 27	1050	2.90	..	1.72	13.37	19.33	3.98	15.35
" 28	835	3.00	14.66			
" "	Sodium chloride, 45 gms. on 29th.							
" 29	740	5.50	2.938	2.35	13.72	18.48	6.65	11.83
" "	Sodium chloride discontinued.							
" 30	1180	8.70	2.468	1.40	11.37	19.68	9.64	10.04
" 31	825	4.40	2.378	1.85	11.86	18.63	6.13	12.50
Sept. 1	1410	1.90	8.75			
" 2	1720	0.92	8.29			
" 3	1350	0.95	7.28			
" "	Soft diet begun on 4th.							
" 4	1160	4.00	8.91			
" 5	1980	4.80	4.69			
" 6	1140	3.20	6.54			
" 13	1350	4.10	2.664	1.92	11.23	15.38	6.40	8.98
" 14	1145	4.15	2.560	1.75	9.41	14.40	6.40	8.00
" 21	900	8.30	2.742	2.05	11.55	23.21	12.61	10.59

TABLE
DAILYI. *Nachtigall*.¹ Milk diet from July 6th to 26th

Date.	Quantity. (c.c.)	Grams per day.			
		NaCl.	Na ₂ SO ₄ .	P ₂ O ₅ .	N.
July 11	650	0.130	1.24	1.07	10.46
" 13	1035	0.206	1.90	1.51	13.11
" 14	887	0.266	1.64	1.24	9.02
" 15	1597	0.798	2.29	1.91	15.14
" 16	828	0.248	1.21	2.48	8.52
" 17	769	0.615	1.36	2.13	9.17
" 18	1153	0.807	2.37	2.65	16.92
The patient received soft diet on the 19th, but returned to milk diet on the 20th.					
July 19	857	0.857	1.74	1.58	14.70
Took three slices of toast and an egg.					
" 21	1479	4.14	2.30	3.18	15.63
From 7 A. M. of the 21st to 7 A. M. of 22d, took 120 gms. NaCl.					
" 22	1183	9.58	2.44	4.26	15.22
" 23	1488	25.15	1.80	3.03	12.13
Sodium chloride discontinued.					
" 24	532	7.91	0.93	1.50	5.86
" 25	1035	7.55	1.79	3.57	13.69
Soft diet begun.					
" 26	1183	5.20	3.17	6.03	21.97
" 27	591	1.77	1.37	1.85	10.74
" 28	798	2.47	1.06	1.01	8.21
" 29	1124	6.30	2.01	1.74	11.60

¹ The daily quantities in the case of *Nachtigall* must be considered unreliable.

III.

URINE.

II. **Boles.** Milk diet from August 19th to September 4th.

Date.	Quantity. (c.c.)	Grams per day.			
		NaCl.	Na ₂ SO ₄ .	P ₂ O ₅ .	N.
Aug. 22	680	0.61	1.50	0.72	8.28
" 23	925	0.51	2.02	1.40	11.16
	Sodium chloride, 30 gms.				
" 24	1080	1.03	2.76	1.48	13.53
" 25	1425	5.28	5.92	1.62	17.81
	Sodium chloride stopped.				
" 26	960	4.51	2.49	1.08	12.63
" 27	1050	3.04		1.81	14.04
" 28	835	2.50			12.24
	Sodium chloride, 45 gms.				
" 29	740	4.07	2.17	1.74	10.15
	Sodium chloride discontinued.				
" 30	1180	10.26	2.91	2.65	13.42
" 31	825	3.63	1.96	1.53	9.79
Sept. 1	1410	2.68			12.04
" 2	1720	1.59			14.27
" 3	1350	1.28			9.83
	Soft diet.				
" 4	1160	4.64			10.34
" 5	1980	9.50			9.29
" 6	1140	3.65			7.42
" 13	1350	5.53	3.60	2.59	15.17
" 14	1145	4.65	2.93	2.00	10.78
" 21	900	7.47	2.47	1.84	10.40

TABLE
CONCENTRATION

I. *Nachtigall*. Milk diet from July 6th to 26th.

Date.	Quantity. (c.c.)	Total molecules.	NaCl.	Na ₂ SO ₄ .	Nitrogen (as urea).
July 11	650	0.7651	0.0063	0.0405	0.5750
" 13	1035	0.5677	0.0064	0.0484	0.4525
" 14	887	0.5339	0.0096	0.0457	0.4075
" 15	...	0.4545	0.0160	0.0372	0.3387
" 16	828	0.5143	0.0095	0.0353	0.3675
" 17	769	0.6794	0.0250	0.0427	0.4262
" 18	1153	0.6556	0.0224	0.0543	0.5500
The patient received soft diet on the 19th, but returned to milk diet on the 20th.					
July 19	857	0.7534	0.0311	0.0489	0.4875
Three slices of toast and one egg.					
" 21	1479	0.5910	0.0881	0.0401	0.3775
120 gms. of sodium chloride from 7 A. M. of the 21st to 7 A. M. of the 23d.					
" 22	1183	0.8513	0.2472	0.0476	0.4612
" 23	1488	1.2174	0.5026	0.0387	0.2862
Sodium chloride discontinued.					
" 24	0.9624	0.4441	0.0370	0.3862
" 25	0.8794	0.2258	0.0389	0.4725
Soft diet begun.					
" 26	0.9688	0.1369	0.0627	0.6362
" 27	0.9455	0.0933	0.0554	0.6487
" 28	0.5883	0.0973	0.0328	0.3675
" 29	0.7513	0.1733	0.0407	0.3687
Aug. 9	0.5164	0.1898	0.0233	0.2437

IV.

IN MOLECULES.

II. **Boles.** Milk diet from August 19th to September 4th.

Date.	Quantity. (c.c.)	Total molecules.	NaCl.	Na ₂ SO ₄ .	Nitrogen (as urea).
Aug. 22	680	0.5243	0.0292	0.0305	0.4350
" 23	925	0.5275	0.0178	0.0301	0.4312
Sodium chloride, 30 gms.					
" 24	1080	0.5354	0.0310	0.0411	0.4475
" 25	1425	0.6455	0.1164	0.0799	0.4462
Sodium chloride stopped.					
" 26	960	0.7170	0.1513	0.0435	0.4587
" 27	1050	0.7392	0.0892	0.4775
" 28	835	0.7290	0.0944	0.5237
Sodium chloride, 45 gms.					
" 29	740	0.8661	0.1692	0.0471	0.4900
Sodium chloride stopped.					
" 30	1180	0.7926	0.2697	0.0396	0.4062
" 31	825	0.7397	0.1380	0.0388	0.4237
Sept. 1	1410	0.5058	0.0593	0.3050
" 2	1720	0.3815	0.0300	0.2962
" 3	1350	0.3418	0.0308	0.2600
Soft diet.					
" 4	1160	0.5508	0.1244	0.3175
" 5	1980	0.3762	0.1503	0.1675
" 6	1140	0.4069	0.1012	0.2337
" 13	1350	0.6265	0.1276	0.0450	0.4012
" 14	1145	0.5635	0.1305	0.0432	0.3437
" 21	900	0.7873	0.2554	0.0440	0.4120

TABLE
VARIOUSI. *Nachtigall*. Milk diet from July 6th to 26th.

Date.	Quantity. (c.c.)	Δ .	Daily molecules. $\Delta \times \text{c.c.}$	Daily molecules. $C \times \text{c.c.}$	Metabolic molecules. (δ)	$\frac{\Delta}{\% \text{ NaCl}}$	$\frac{\Delta}{\delta}$
July 11	650	1.446	940.0	497.31	1.4338	72.30	1.01
" 13	1035	1.073	1110.0	587.59	1.0608	53.65	1.00
" 14	887	1.009	895.0	473.56	1.0007	33.63	1.00
" 15	1597	0.859	1370.8	698.89	0.8285	17.18	1.04
" 16	828	0.972	804.8	425.84	0.9537	32.46	1.02
" 17	769	1.284	987.4	522.43	1.2352	16.10	1.04
" 18	1153	1.239	1428.5	755.93	1.1963	17.70	1.03
The patient received soft diet on the 19th, but returned to milk diet on the 20th.							
July 19	857	1.424	1220.3	645.86	1.3630	14.24	1.04
Three slices of toast and one egg.							
" 21	1479	1.117	1652.0	874.09	0.9462	3.99	1.18
120 gms. of sodium chloride were given during the two days, beginning with 7 A. M. of the 21st and ending with 7 A. M. of the 23d.							
July 22	1183	1.609	1903.4	1006.08	1.1049	1.97	1.45
" 23	1488	2.301	3407.3	1800.49	1.2701	1.40	1.81
Sodium chloride stopped.							
" 24	532	1.819	967.71	511.00	0.9390	1.25	1.94
" 25	1035	1.662	1720.17	910.18	1.2176	2.28	1.36
Soft diet begun.							
" 26	1183	1.831	2168.07	1146.08	1.5526	4.16	1.11
" 27	581	1.787	1056.12	558.80	1.6040	5.96	1.11
" 28	798	1.112	887.37	469.46	0.9229	3.59	1.20
" 29	1124	1.420	1596.08	844.46	1.0784	2.53	1.32
Aug. 9	0.976	0.6039	1.60	1.61

V.

FACTORS.

II. **Boles.** Milk diet from August 19th to September 4th.

Date.	Quantity. (c.c.)	Δ .	Daily molecules. $\Delta \times \text{c.c.}$	Daily molecules. $C \times \text{c.c.}$	Metabolic molecules. (δ)	$\frac{\Delta}{\% \text{ NaCl}}$	$\frac{\Delta}{\delta}$
Aug. 22	680	0.991	673.8	356.52	0.9301	11.01	1.06
" 23	925	0.997	922.2	487.94	0.9635	18.12	1.03
	Sodium chloride, 30 gms.						
" 24	1080	1.012	1093.0	578.23	0.9538	10.60	1.06
" 25	1425	1.220	1738.5	919.84	0.9933	3.30	1.23
	Sodium chloride stopped.						
" 26	960	1.355	1300.8	687.32	1.0683	2.88	1.27
" 27	1050	1.397	1476.8	776.16	1.2201	4.82	1.14
" 28	835	1.378	1150.6	608.80	1.1950	4.59	1.16
	Sodium chloride, 45 gms.						
" 29	740	1.637	1211.4	640.61	1.3015	2.98	1.28
	Sodium chloride discontinued.						
" 30	1180	1.498	1767.6	935.29	0.9673	1.72	1.55
" 31	825	1.398	1153.3	610.15	1.1296	3.18	1.24
Sept. 1	1410	0.956	1348.0	713.18	0.8401	5.03	1.14
" 2	1720	0.721	1240.1	656.18	0.6646	7.95	1.09
" 3	1350	0.646	872.1	461.43	0.5878	6.80	1.10
	Soft diet.						
" 4	1160	1.041	1207.5	638.93	0.7970	2.60	1.31
" 5	1980	0.711	1407.7	744.88	0.4182	1.69	1.70
" 6	1140	0.769	876.6	463.87	0.5737	2.40	1.34
" 13	1350	1.184	1597.4	845.77	0.9340	2.89	1.27
" 14	1145	1.065	1219.4	645.21	0.8119	2.57	1.31
" 21	900	1.488	1339.2	708.57	0.9817	1.79	1.51

CURVES.

The curves are plotted from Boles' urine. They require no further explanation.

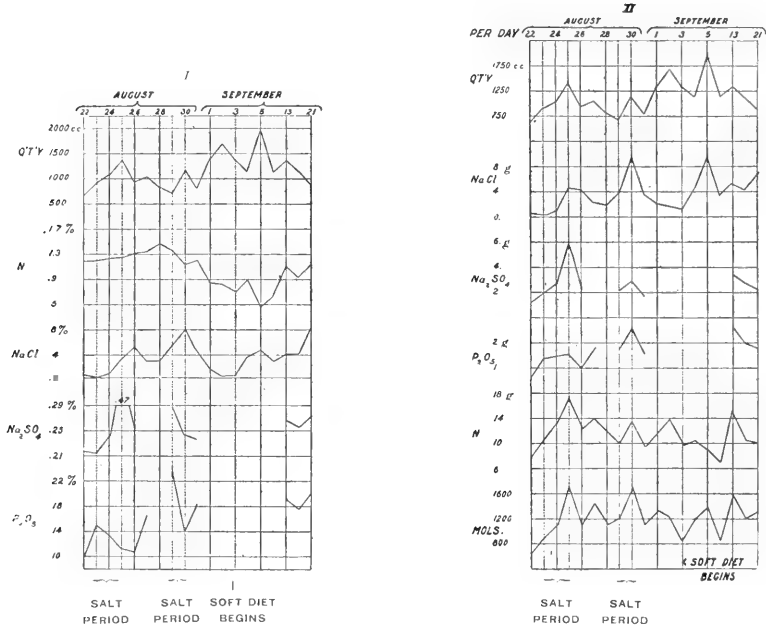

PERCENTAGE OF THE CONSTITUENTS.

GRAMS PER DAY.

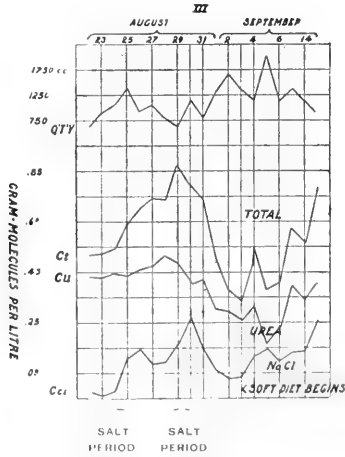

THE MECHANISM OF THE RETENTION OF CHLORIDES: A CONTRIBUTION TO THE THEORY OF URINE SECRETION.

By TORALD SOLLMANN, M.D.

[From the Pharmacological Laboratory of the Medical Department of Western Reserve University, Cleveland, Ohio.]

CONTENTS.

	Page
I. The retention of chlorides in fever	156
II. The retention of chlorides when salts are deficient in the food	159
III. The retention of chlorides after sulphate injections	161
IV. Do other salts suppress the chlorides in the same manner as do the sulphates?	162
V. Forster's theory of the retention of chlorides	163
VI. Cushny's theory of the reabsorption of chlorides	167
VII. Is the reabsorption a sufficient explanation for the absence of chlorides in the urine?	169
VIII. Is the glomerular fluid formed by filtration or by secretion?	171
IX. Conclusions	173
X. Bibliography	173

THE urine becomes almost or quite chloride free in infectious diseases, in salt starvation, and on intravenous injection of Na_2SO_4 solution. The research recorded in the preceding paper led me to inquire into the mechanism of this chloride retention.

Three very different theories have been advanced to account for the phenomena: one theory assumes that no chloride is filtered. This was first definitely formulated by Forster. Another theory assumes that the chlorides are filtered in the glomeruli, very much as when retention does not occur; but that the chloride is reabsorbed. This has been supported by Cushny. The third, which grants to the glomerular cells the property of vital secretion, assumes that these cells secrete no salts when the proportion of salts in the blood falls below a certain amount.

These explanations involve respectively the theories that the urinary salts are filtered, reabsorbed, and secreted. Each of these theories has been called into doubt, so that the study of the question of chloride

retention offers a peculiar interest, and may be expected to throw light on the whole subject of urine secretion.

In this study I have availed myself very freely of the published records of other observers, but have also introduced my own experiments when these seemed more suitable. In presenting the subject I will first analyze the conditions under which the chloride-retention is seen, and then the theories by which the retention has been explained.

I. THE RETENTION OF CHLORIDES IN FEVER.

The earlier literature relating to the chlorides of the urine in fever is given by Röhmann (1).¹ It appears that Redtenbacher (2) in 1850 was the first to discover that the chlorides disappear completely, or almost completely, from the urine in genuine pneumonia. Unruh (3) extended this observation to typhoid and other acute fevers, as also to abscess formation, trichinosis, aortic insufficiency, etc.

Such a striking phenomenon could not fail to elicit inquiry and bring forth attempts at an explanation. Deficiency of the chlorides in the food was perhaps the most apparent cause, and this was one of the earliest explanations advanced. Other suggested explanations are, that the chlorine is retained in the exudates, or excreted by other channels, — especially by the stools, if there existed diarrhœa, — by the sputum, sweat, etc., or that a storage of the chlorine occurs.

1. **Is there a storage of chlorides in the body?** — Röhmann (1) seems to have been the first to compare carefully the income of chlorine, and its elimination by the urine and fœces. He found that there is an actual retention of chlorine during the febrile period, often persisting for several days after the crisis. The difference between the income and output of chlorine is, however, quite small, usually less than two grams per day. He proves that this retention cannot be accounted for by faulty absorption of the salt from the alimentary canal.

Röhmann explains the cause of the storage of chlorine by the febrile changes of metabolism, on an adaptation of Forster's theory. Forster (5) believes that the greater part of the salts of the body is united with proteids, forming proteid-salt combinations which cannot be excreted by the urine. Röhmann considers that the altered met-

¹ The numbers refer to the Bibliography at the end of this paper.

abolism of fever causes tissue proteids to be converted into "circulating" proteid, and that the latter requires more chlorine. Critics of this theory have not been wanting. It has been pointed out that it would first need to be demonstrated that circulating proteid contains more chlorine; secondly, that the circulating proteid is increased. As to the former, Langlois and Richet (4) have recently shown that the blood contains two or three times more chlorine than any of the organs, so that the circulating proteid-containing liquids may be considered to be the richer in chlorine. But the theory that the circulating proteid is increased in fever, is not supported by facts. Nor is it easy to see why such an increase of circulating proteid should occur. To the contrary, fever causes an increased destruction of proteids; and this, by Forster's theory, should lead to a liberation and excretion of salts, to a loss of salts, instead of a salt retention. That an increased destruction of proteids does lead to a loss of salts seems amply demonstrated. Kast (9) administered poisons which caused a destruction of blood-corpuscles — such as CO, pyrogallol, and toluylendiamin — or such as increase the destruction of tissue, as phosphorus. These caused an increase of chlorine excretion, generally parallel to the N, and fairly independent of the quantity of urine. A similar increase of chlorine excretion accompanies the pre-mortal rise of N in starving animals. This was observed by Forster (5) and also by Kast (9). Our figures for Nachtigall, comparing the beginning and end of starvation period (July 11 and 17), also show an increase of chlorine, but since this is not proportional to the nitrogen, its cause is probably extraneous.

These facts are certainly adverse to Röhmann's theory. For the only effect of fever on proteids which we know with certainty is, that there is an increased destruction, which should lead to a loss of salts. Indeed, the results of Gramatchikov (6) disagree entirely with those of Röhmann. Gramatchikov found that the body actually lost a small amount of chlorine in fever. The difference is perhaps to be explained by the original content of the patients in chlorine, or by other factors, such as the diet and its content in chlorine, or the amount of tissue destruction, etc.

Röhmann's results show that there may undoubtedly be a retention, even with as small a chlorine income as exists in fever. That a temporary storage may occur when larger quantities of salt are administered, is well known. We wished to confirm this fact on our cases by observing the total income and elimination of chlorides, but had

to abandon the attempt, as it was found impossible to control the food and collect the excreta of the patients with sufficient precision. However, the fact that the excretion of chlorine does not reach its maximum until the second day after the administration of sodium chloride, and does not return to normal until about the fifth day, argues in our results also for a chlorine retention under these conditions. It is supported by all other experiments on sodium chloride administration.

Röhmman found that the maximum excretion fell usually on the second day, and remained high for three days, when the entire administered quantity was excreted. Lauder-Brunton (7) quotes from Ludwig's Lectures (1869-1870) that, if a definite quantity of sodium chloride be taken daily for some time, the quantity excreted by the urine becomes practically equal to that ingested. If the consumption is now increased, the excretion does not increase (correspondingly?) for about three days, so that a storage must occur. After further three days, the quantity excreted will again equal that ingested. Diminution of the sodium chloride of the food has a corresponding result, requiring the same time to produce equilibrium. Krummacher (8) finds that when sodium chloride is injected hypodermically, two days are required for practically complete excretion.

Whilst the administration of sodium chloride certainly leads to a storage of sodium chloride, this is purely temporary if the body possesses a normal amount of sodium chloride to begin with. Langlois and Richet (4) did not find the chlorine content of the tissues modified by adding sodium chloride to the food.

2. Retention of chlorides in effusions. — Giving all possible weight to Röhmman's data and experiments, it must be said that the binding of salts by the "circulating" proteids can play but a very subordinate rôle in the retention of the chlorides. A much more important factor is the formation of effusions, when such occur.

This explanation was already advocated by Redtenbacher (2). M. Schubert (10) has studied this phenomenon in four cases of ascites from hepatic cirrhosis. Whenever puncture was performed and the liquid drawn off, the sodium chloride of the urine sank greatly and recovered only slowly. The decrease existed only in the daily excretion, the percentage remaining normal. There was also a similar decrease in the daily excretion of nitrogen, and in the quantity of urine. This retention therefore differs radically from that encountered in fever and hunger,

as may be seen, for instance, from our results on the typhoid urines: In the latter the percentage of the sodium chloride in the urine is reduced, as well as the daily quantity, whilst the nitrogen and the quantity of the urine are but little altered. The two conditions can therefore be readily distinguished.

I have only encountered a single statement concerning the physico-chemical constitution of the urine in ascites. Waldvogel (11) found the factor $\frac{\Delta}{\text{NaCl}}$ raised. This indicates that the chlorine retention is greater than the retention of other solids; it might, however, be explainable by the interference of the ascites with the renal circulation.

As a converse, it has been found (12) that a very large quantity of chlorine is excreted by the urine during the absorption of effusions. The chlorine excretion is said to be much larger than what would correspond to the nitrogen excretion.

3. Retention of chlorides through the formation of other secretions, of blood, and of solid tissues.—That the loss of chlorides through the sputum, through diarrhœic stools, etc., will lead to diminished excretion of chlorides by the urine, may be granted *a priori*.

A retention of chlorides also occurs when chlorine is lost through hemorrhage. This has been shown on animals by Kast (9), and has also been demonstrated on man (14). The effect is precisely the same as described in the formation of effusions.

An increased growth of tissue, joined with exudations, also diminishes the chloride excretion, as may be seen in many cases of carcinoma (15).

II. THE RETENTION OF CHLORIDES WHEN SALTS ARE DEFICIENT IN THE FOOD.

After a liberal value is assigned to Röhmann's theory, and to the retention of chlorides by effusions, etc., the greater part of the phenomenon of chloride-retention in fever is still unaccounted for. The real explanation is to be found in a deficient salt income. The diet of fever patients is always scanty, but is particularly poor in chlorides. The composition of the urine corresponds almost precisely to what is seen after a corresponding diminution of chloride-income in health. I am therefore inclined to regard the chloride-retention of fever as depending practically purely on the diet, and consider it no more a reliable index to the severity of the disease, than is the appetite of the patient, by which it is controlled.

The great influence of the diet on the salt excretion justifies a close study of its effects. I have already presented these in a contemporary paper in "American Medicine" (Oct. 25, 1902).

Falk (1848) is said (16) to have been the first to prove that the sodium chloride of the urine varies with that of the food. Bidder and Schmidt in 1852 (17) observed in hunger the practical disappearance of chlorine from the urine at a time when there was still a large quantity of chlorine in the body. Forster (5) in 1873 shows that the chlorine of the urine is reduced to mere traces when food nearly free from salt is given; but that some trace is excreted until the death of the animal. The great diminution of chlorine in fasting can also be seen in an interesting manner in the observations of Hoover and Sollmann (18) on metabolism during fasting in hypnotic sleep. In this case no solids were taken for a week, but water was allowed *ad libitum*. The percentage of chlorine sank immediately and rapidly and after a few days remained at a fairly constant, low level. Lindemann (13, p. 15) finds the percentage of sodium chloride in fasting (five cases) to fall to 0.17 to 0.20 per cent, mean 0.18. This is not quite as low as the figures obtained by Hatcher and myself. However, there is considerable reason to believe that the other salts of the milk save sodium chloride from excretion; and even the proteids of the milk may have a saving influence on the chlorine, by saving the proteids of the body from destruction. In support of this, Forster found (5, p. 354) that the less the quantity of salt-free food, the greater was the loss of P_2O_5 in the urine; and again (p. 358) that more salts are excreted in hunger than when salt-free food is given. Langlois and Richet (4) found that fasting, with or without administration of sodium chloride, does not lower the content of the tissues or blood in chlorides (*i. e.*, the excretion of chloride corresponds to the destruction of tissue); but feeding with chloride-poor food causes a diminution of 10 per cent in the sodium chloride of the tissues (no diminution in the blood). This is reconcilable with Forster's results, on the theory that the body weight did not diminish as greatly during the experiment as in plain fasting. The addition of other salts to chloride-poor diet did not alter the loss in either direction.

The effects of a chloride-poor diet on the other salts of the urine have been given in the preceding paper, so that it will not be necessary to repeat them in this place.

The effects of a deficient chloride income on the tissues and fluids other than the urine, have also been investigated. Langlois and Richet (4) showed that chloride-poor food lowered the chlorine of

the tissues, but not that of the blood; the blood indeed retains its chlorine with great tenacity, and is the last component of the body to participate demonstrably in a chlorine loss.

The effect of salt starvation on the chlorine of the gastric juice has been investigated by Forster and by Cahn. Forster (5) found that the gastric juice still contained 0.07 per cent of chlorine when the urine had become free from chlorine. Cahn (19, p. 532) confirms the persistence of sodium chloride in the gastric juice in advanced salt starvation, but observes that the secretion of *free* hydrochloric acid ceases when the chlorine content of the body falls below a certain amount, and recommences as soon as chlorine is administered.

Salt starvation, therefore, diminishes the chlorine of the gastric juice, but not as readily nor as profoundly as it reduces the chlorine of the urine.

III. THE RETENTION OF CHLORIDES AFTER SULPHATE INJECTION.

Magnus in 1900 (21, II, p. 417) discovered that the chlorides disappear almost completely from the urine when a solution of sodium sulphate is injected intravenously. The fact was also discovered independently by me in 1899 (22, p. 20). In the three experiments which I made, the disappearance occurred only in the two (Exps. VI and VII) in which a considerable diuresis was produced. In the third (Exp. IX) the excretion of the urine was only moderately increased, and in this the percentage of sodium chloride in the urine only fell to 0.17 per cent.

Further experiments in this direction have recently been published by Cushny (23). His results are very contradictory. He states (p. 436) that injection of sodium sulphate alone usually *increased* the chlorine of the urine. On the other hand, when mixed solutions of sodium chloride and sodium sulphate were injected, the chlorine *disappeared* entirely from the urine in one and one-half hours (Exp. I, p. 432). Pototzky (41) also finds that sulphate injection increases the chlorine excretion in salt-starved rabbits.

Cushny's and Pototzky's experiments were made on rabbits, whilst Magnus and I used dogs. This difference in the animals may account for the different results; for Magnus has shown that these animals do not possess the same retaining power for different salts. He states (21, II, p. 405) that when sodium chloride was injected, both rabbits and dogs retained at the end of the experiment two-thirds of the injected salts; but when sodium sulphate was injected, the rabbits retained two-thirds, and the

dogs only one-tenth. A difference exists also in the excretion of phosphates; Bergmann (24) claims that carnivorous animals excrete the major part of the phosphates by the urine, whereas herbivorous animals excrete injected phosphates almost entirely by the feces.¹

In all the sodium sulphate injections made by Magnus and by me, it can further be seen that the sodium chloride does not leave the blood by any other channel. On the contrary, the total amount of chlorine in the blood is increased after the injection of the sulphates. The increase is probably to be attributed to the diminished partial osmotic pressure of the chlorine ions in the serum.

IV. DO OTHER SALTS SUPPRESS THE CHLORIDES IN THE SAME MANNER AS DO THE SULPHATES?

1. **Sodium nitrate.**— I had planned to extend my former experiments on salt injections to other salts; but so far I have only found time for a single experiment with sodium nitrate. A dog was used. The method was the same as in my former experiments (22), employing 75 c.c. per kilo of a solution of sodium nitrate, Δ 0.481. The urine contained at first 4 per cent of sodium chloride; in one and three-quarter hours it contained 2.8; in six hours the sodium chloride was still 2.4 per cent. The diuresis was quite profuse. The result differs so greatly from that seen with sodium sulphate that there need be little hesitation in affirming that sodium nitrate does not suppress the chlorine of the urine. This conclusion is confirmed by the effect which the oral administration of potassium nitrate produces in animals whose urine has been rendered chlorine free by salt hunger.

A. Cahn (9) mentions that potassium nitrate causes chlorine to appear in this condition. He does not give the source of this statement, but confirms it by some experiments of his own. He found that in the dog the administration of potassium nitrate raised the chlorine from a trace to 0.119 gm. per day (p. 528). The urine happened to be reduced from 1500 to 100 c.c. He states (p. 523) that sodium nitrate was ineffectual, but this conclusion may be challenged, since only a single experiment was made; as the salt was given by the mouth, there could have been defective absorption or some other interfering factor.

¹ In this he differs, however, from Cushny (23, p. 442 and 443) who recovered 77 per cent of the injected P_2O_5 from the urine in three hours. Cushny worked with rabbits, Bergmann with sheep.

Langlois and Richet (4) also found that the chlorine of the tissues and blood was greatly reduced on the injection of large doses of nitrates into starving animals.

2. **Sugar.**—Cahn, as also Langlois and Richet, found that this behaved very similar to nitrates.

3. **Urea.**—That urea does not cause a retention of chlorine may be argued from the normal occurrence in urine of large amounts of both substances. Katsuyama (29, p. 237), giving urea by the mouth to rabbits whose urine had been rendered chlorine free by fasting, found that this caused a very considerable excretion of chlorine, sometimes quite independent of diuresis (Exp. 3).

In this respect urea bears a close resemblance to the nitrate. Caffein and theobromin also produces a similar effect.

4. No data regarding the chlorine excretion in *phosphate* injection could be found in the literature.

V. FORSTER'S THEORY OF THE RETENTION OF CHLORIDES.

1. The serious difficulty offered to the filtration theory of urine secretion by the retention of chloride in salt starvation, when the composition of the blood is but slightly altered, was recognized by Forster (1873). He proposed the following explanation (5, p. 318): The larger part of the soluble salts of the organism exists in firm combination with the organic substances, particularly with the proteids of the tissues, juices, and blood. Another, much smaller quantity, is present in simple solution, in a free state. The former—the salt-proteid compounds—are incapable of filtration in the kidneys. Whenever the proteids are saturated with salt, any additional quantity of salt is filtered off rapidly into the urine. The excretion of salts is therefore practically equal to the salt income. When salts are withheld entirely, their excretion should also cease completely. That a small quantity of salt is still excreted in salt hunger, he explains by the combustion of proteids, during which the combined salts are liberated. When the proteid combination is under-saturated, as must occur when salt-free proteids are fed, this liberated salt should combine with the unsaturated proteid, and should thus be utilized over and over again, without being excreted. He assumes that this utilization occurs, but that the combination requires time; that meanwhile the salt circulates free, and thus a fraction passes through the urinary filter.

2. This theory of Forster's, that the urine is a filtrate containing not the entire ash, but only the free salts, seems to have fallen completely into oblivion; yet it is a very plausible hypothesis, which agrees excellently with the experiments made by Forster. It would, moreover, explain a large number of other obscure physiological phenomena, such as the remarkable tendency of the blood to preserve a constant composition; the fact that sugar is not excreted until its proportion rises above 0.2 per cent, but that all above this is eliminated; the fact that no urine is excreted unless a "harnfähige Substanz," — *i. e.*, a substance capable of being secreted by the urine — is added in the blood, as seen from the experiments of Munk, of Nussbaum, Beddard and Halsey, of Magnus, and of Spiro.

I. Munk (25) showed that if the blood of a fasting dog is circulated through an excised dog's kidney, no secretion occurs, but that secretion is started when chloride, urea, sugar, etc., are added to such blood. In Nussbaum's experiments (26) it was noted that no secretion of urine occurred after ligation of the renal artery, until urea was injected. This was confirmed by Adami, and by A. P. Beddard (27, pp. 26 and 27). An experiment made by Magnus is most interesting in this connection (21, III, pp. 213–216). He finds that increasing the quantity of blood in a rabbit or dog by 84 per cent, by transfusion of blood from another animal which has been kept under identical conditions, does not cause diuresis. In this he confirms Ponfick's observation (quoted *Ibid.*, p. 212). If the composition of the injected blood is not the same — as when the animal has received an injection of sodium sulphate — diuresis results.

Spiro (28) finds (p. 150) that injections of solutions of colloids — gums or gelatine — into animals which have fasted twenty-four to forty hours, gave no diuresis, although the quantity of blood was increased by 78 to 90 per cent. If, on the other hand, the animals had been fed, and especially, watered freely, a good diuresis resulted (p. 152). This could be interpreted as showing that these colloids hold their own "aggregate" composition against the urinary filtration tendency; and that diuresis will only result from them if filtrable substances are present in excess. Indeed even caffeine cannot produce diuresis after the injection of colloids unless such filtrable substances are present.

Forster's theory could also be made to explain why one animal reacts to a given amount of a diuretic by a large diuresis, whilst another animal may show but very little response: an animal poor in substances capable of passing into the urine would react less readily than one which contains an excess of such substances.

The difference of diuretic effect of equimolecular solutions of different salts could also be explained on physical principles by this theory: if it be assumed that sodium chloride enters more readily into non-filtrable combination with the colloids than does sodium sulphate, the latter should produce the greater diuretic effect.

A further support of Forster's theory could be sought in the modern theories of the physical condition of colloids. In accordance with these, the non-filtrable proteid salt compounds assumed by Forster's theory could be conceived as "molecular aggregates."

It must be granted that all the physiological phenomena for the explanation of which I have invoked Forster's theory, could be equally well explained by the theory of vital secretion, by assuming that an abnormal composition of the blood serves as a necessary stimulus to the excreting cells, causing them to eliminate what substances are responsible for the abnormality.

The physical theory of Forster possesses the advantage of simplicity. Attractive and adequate as this theory appears on cursory examination, it must be said to lose very much of its force when it is examined more critically. It can only be allowed to stand if it is proved: that the ratio of salts and colloid varies only within certain limits; that proteids do combine with salts; that filters can be constructed which retain the proteids and the greater part of the salts of the serum, but which allow added salts to pass freely.

3. **Is the ratio of salts to colloids constant?**—Forster's theory conceives the combination of proteids and salts to contain variable proportions, tending, however, toward a certain constant. When the salts fall below this constant, they tend to be retained; if they exist in greater proportion, they will be excreted. As a matter of fact, it is found that when sodium chloride is administered, a certain amount is retained, and the quantity retained is the greater, the lower the original salt-content of the body. The experiments of Spiro on the injection of colloids also speak for the fact that colloids poor in salts tend to retain sodium chloride in the body. It can also be noticed that the ratio of organic matter and ash of the serum varies within considerable limits in different animals. All these facts agree well with Forster's theory, but it must be acknowledged that an actual combination of salt and colloid is not necessary for their explanation.

4. **Has any combination between proteids and salts been demonstrated?** — The answer to this question must be entirely in the negative. Bugarszky and Liebermann (33) found that no change occurs in the freezing-point of a sodium chloride solution when egg albumin or albumose are added to it. I have confirmed this on albumoses, and have further shown that solutions of these dissociate precisely as does their ash (34). Indeed the freezing-point of serum can only be explained by assuming dissociation of its salts. Whilst we do not yet know sufficient about “molecular aggregates” to affirm that their constituents cannot exist in dissociated form, yet it is scarcely conceivable that salts could exist combined into aggregates, and still possess the physical properties of free ions. The observation of Moore and Parker (35, p. 280) that the aggregates of soap possess a physical molecular weight twenty to sixty times as great as their chemical molecular weight, certainly speaks against this assumption.

5. **The filtration of colloid solutions.** — Ludwig’s theory assumes the glomeruli to represent a filtering apparatus which allows the passage of water and salts, but not of proteids. Martin (30) has shown how to construct, artificially, filters of this kind by coating Pasteur-Chamberland filters with gelatin, or silicic acid, and filtering under pressure. These filters form a very close approximation to the theoretical filter assumed by Ludwig. They would seem to be a fair method of directly testing the question: Whether the filtrate from a colloid mixture really represents the mixture minus the colloids? or in other words: whether the filtrate from, say, serum, is simply a proteid-freed serum?

The experiment was tried by E. H. Starling (31, p. 318). He obtained the erroneous result that the filtrate has within $\frac{1}{100}^{\circ}$ C, the same Δ as the serum, — *i. e.*, that the filtrate is purely a proteid-freed serum. The error was shown by Waymouth Reid (32, p. 169), who investigated the subject more fully, and with due precautions. He finds that the filtrate is very markedly less concentrated than the serum; that it has been deprived, not only of the proteids, but also of the greater part of the non-proteid solids, and of a fair amount of the ash.

The organic non-proteid solids were reduced from 5.06 to 0.78 per cent.

The ash “ “ “ “ “ 9.42 to 8.85 “ “

The Δ “ “ “ “ by 0.035 to 0.060° C.

In dog’s bile the ash was reduced from 4.42 to 0.76 per cent.

The fact that the filtrate is more dilute than the serum cannot, however, be considered as a confirmation of Forster's theory. This theory demands that the salts should be mainly in the unfiltered portion, but the experiment shows that the salt content of the filtrate is but very little lowered. Nor can the retention of organic substances be regarded as due to a combination, for a similar retention occurs when a pure solution of dextrose is subjected to this filtration; the filtrate is in this case also less concentrated than the original solution.

Waymouth Reid's experiments show that filtration may retain certain substances, and in this way produce a considerable diminution in the concentration of the filtrate. But this retention is not due to any proteid-salt combination, but to the fact that the molecules of the dissolved substance pass less readily through the filter than does water.

We must conclude that *the direct evidence of chemical and physical experiments is against Forster's theory.*

VI. CUSHNY'S THEORY OF THE REABSORPTION OF CHLORIDES.

The theory that sodium chloride is reabsorbed from the glomerular fluid, presumably by the epithelium of the convoluted tubules, has found its best support in the recent experiments of Cushny (23 and 36). Cushny, in agreement with Starling (31, p. 317), looks upon the glomerular liquid as a simple filtrate of the serum, containing practically all its non-proteid constituents in the original amount and ratio (p. 449). As this passes through the urinary tubules, water and the more diffusible constituents are reabsorbed (p. 429). Sodium chloride is very readily absorbed; P_2O_5 , SO_4 , and urea with increasing difficulty. A retention of chlorides — a paucity of the urine in chlorides — can, according to him, be due only to two causes: to a paucity of chloride in the blood which would lessen the filtration; or to slow excretion of urine which would favor reabsorption. It must, if I understand him correctly, be strictly proportional to these.

These conclusions are based on the following experiments:

Cushny (23) injected into rabbits a mixture of equimolecular solutions of sodium chloride and sodium sulphate. In the urine the equimolecular ratio of $Cl : SO_4$ was (p. 434):

In the early stages of active diuresis, :: 108 : 94;

In the later stages of slow diuresis, :: 110 : 156.

In other words, the concentration in the sodium chloride was proportional to the diuresis, whereas the sodium sulphate was inverse to the diuresis.

The difference between chlorine and sulphate is brought out still more clearly by another mode of calculating (p. 436) :

The kidneys secrete in the first stage a urine in which the chlorine stands to the chlorine of the plasma as 2 : 3 ; in the last phase, as 1 : 5 ; sulphate, first phase 2 : 1 ; last 10 : 1.

These facts are most readily explained by assuming that the sodium chloride is reabsorbed, in proportion to the time during which the urine remains in the kidney ; whereas the sodium sulphate is not capable of reabsorption in the same degree. Extending the method to urea (p. 444) and phosphates (p. 442), he finds that these are also not readily absorbed, urea being the most resistant of all.

The dependence of the amounts of chlorides on the diuresis is still more strikingly established by Cushny's experiment on partial occlusion of the ureter (35) ; operating as in his other experiments, but partially occluding one ureter and comparing the urine from the two kidneys, he finds that on the side of the occluded ureter the water is lessened by 66 per cent, chlorine by 82 per cent, sulphate by 30 per cent.

These conclusions are further borne out by the results of numerous experiments made by other observers for other purposes, such as those of Munk and Senator (37), Magnus (21), as also by my experiments (22). They also agree very well with clinical observations. Von Koranyi's theory, which is based mainly on clinical facts, coincides with Cushny's.

This theory involves a selective absorption of the urinary ingredients. Viewing it, as we must, as a vital process, the difference in the absorbability of the chlorides and of urea finds many analogies. In my former paper (22, p. 19), in advancing this difference as evidence against the theory of reabsorption, I had in mind a physical, not a vital reabsorption.

The reabsorption of chlorides may be considered as demonstrated. — I take exception, however, to two other views of Cushny, — viz., that the reabsorption is an adequate explanation for the practical disappearance of chlorides in the urine, and that the glomerular fluid is a filtrate, identical with proteid-free serum.

VII. IS THE REABSORPTION A SUFFICIENT EXPLANATION FOR THE ABSENCE OF CHLORIDES IN THE URINE?

According to Cushny's theory the amount of chlorides in the urine is determined by two factors: The diuresis, and the quantity of chlorides in the serum. It can, however, be easily shown that the excretion of the chlorides can be altered in either direction without altering these two factors in a corresponding degree; and that it is sometimes even the opposite of what is demanded by Cushny's theory:

In starvation, the quantity of the urine is practically unaltered, or may be even greater than normal. With sodium sulphate injection, the diuresis is very large. In both these cases the chlorides disappear from the urine. In other words, the results are precisely the opposite of those demanded by Cushny's theory. Nor can this discrepancy be explained by a proportionately altered composition of the blood. For according to Cushny's theory the amount of chlorides for a given excretion of urine should be strictly proportional to their quantity in the blood. Yet the chloride of the blood and the tissues is scarcely altered by starvation.

In the case of sodium sulphate we have analytical data which show the insufficiency of Cushny's explanation in a still more striking light, if possible.

On injecting sodium sulphate, Magnus (21, II, p. 417) found that the sodium chloride of the serum sank only from 0.632 per cent to 0.6 per cent; whereas it sank in the urine to only 0.05 per cent; sodium sulphate rose in the serum from 0.034 to 0.272 per cent; in the urine to 3.124 per cent. This could only be explained by an enormous reabsorption of chlorine; yet there was a good diuresis.

In my own experiments I found:

EXPERIMENT VI.

Injection of sixty-three per cent of the blood quantity of Na_2SO_4 solution Δ 0.544.

	Serum.		Urine.		Urine secretion. c.c. p. kg. p. 10 min.
	NaCl.	Other salts.	NaCl. Per cent.	Other salts. Per cent.	
Before injection	5.60	2.67	4.27	7.18	
10 minutes after	4.56	5.62	Trace	19.85	4.4
30 minutes after	5.03	4.40	"	21.98	3.2

EXPERIMENT VII.

Injection of ninety-nine per cent of the blood quantity of Na_2SO_4 solution Δ 0.606.

	Serum.		Urine.		Urine secretion. c.c. p. kg. p. 10 min.
	NaCl.	Other salts.	NaCl. Per cent.	Other salts. Per cent.	
Before injection	5.70	2.85	1.05	6.56	
4 minutes after	4.26	7.26			
15 minutes after	Trace	18.09	5.4
45 minutes after	4.46	4.39	0.4	19.07	5.7

It is seen that the excretion of chlorides is suppressed when the blood contains quite a high percentage of this ion, and when the diuresis is very large.

In Katsuyama's experiments on the effect of diuretics (29) on rabbits deprived of food and water, he finds, indeed, that diuresis increases the per cent of sodium chloride; yet this fact, instead of favoring Cushny's explanation, really controverts it; for the increase is out of all proportion. Indeed, these diuretics increase the chloride equally, whether they produce diuresis or not.

Thus in Experiment III, p. 237, the quantity of normal urine was 67; Cl, trace. On the day after giving urea, the quantity was 64; Cl, 0.17:0.

In Experiment VI the normal quantity of urine was 39; Cl, trace. After diuresis, the normal quantity of urine was 32; Cl, 0.48 per cent.

In the case of fasting in hypnotic sleep, observed by Hoover and Sollmann (18), an increase of diuresis from 410 to 560 c.c. instead of increasing the percentage of chlorine, lessened it from 0.6 to 0.43 per cent.

Similar instances could be multiplied. It is evident that neither deficient filtration, nor reabsorption from prolonged sojourn in the tubules, can explain these conspicuous exceptions to Cushny's theory.

When the diuresis is not greatly altered, there can be no doubt that the composition of the urine depends mainly upon the composition of the serum. The very fact that the intravenous injection of any substance capable of passing into the urine, increases the excretion of this substance, is sufficient to prove this. Yet even much smaller variations in the blood find expression in the urine. Thus V. Koranyi (38, p. 10) showed that in the rabbit the factor

$\frac{\Delta}{\text{NaCl}}$ of the urine varied in the same direction as the corresponding

factor of the serum. Only — and this is important — the range is much greater in the urine (urine, 1.13 to 13.92; serum, 0.86 to 1.25). The dependence of large changes in the chloride excretion upon small changes in the blood can only be explained by a vital theory; in the case of chloride retention, either by a stimulation of the absorbing cells, or by a cessation of the secretion of chloride. I shall discuss this question in the next paragraph.

VIII. IS THE GLOMERULAR FLUID FORMED BY FILTRATION OR BY SECRETION ?

By the filtration theory of urine formation the blood-pressure in the glomerular capillaries must exceed the ureter pressure by a greater amount, than the osmotic pressure of the serum exceeds the osmotic pressure of the glomerular fluid. Otherwise no filtration is possible, for the blood-pressure would not suffice to overcome the osmotic pressure. The composition of the glomerular fluid differs from that of the serum at least by the proteids. Starling (31, p. 321) has calculated the osmotic pressure of the serum proteid as 25 to 30 mm. of mercury.

In order to establish the filtration theory as the only factor in the formation of urine, it is necessary to prove :

(1) That the secretion of the urine stops when the blood-pressure falls to less than 40 mm. mercury above the ureter-pressure.

(2) That the osmotic pressure of the glomerular fluid differs from that of the serum by not more than 30 mm. of mercury.

(1) **Does the secretion of urine cease when the ureter and blood pressure differ by less than 40 mm. of mercury ?** — Starling (31) found in his experiments that the secretion of the urine stops when the carotid pressure falls to 40 mm. mercury. He concludes from this that the blood-pressure is sufficient to filter a proteid-free urine. Moore and Parker (35) justly criticise this conclusion, on the ground that it is not the carotid, but the glomerular pressure which must be effective, and the pressure in the glomeruli must be considerable less than that in the carotid.

The experiments of Gottlieb and Magnus (21, V) confute Starling's conclusions still more effectually. These authors found that the urine was secreted with an arterial pressure as low as 16 mm. (p. 253); a very small quantity was secreted even when the arterial pressure surpassed the ureter pressure by only 2 mm. Hg (p. 254).

(2) The osmotic pressure of the glomerular filtrate may differ from that of the serum by much more than 40 mm. mercury. — The experiments of Waymouth Reid (32) have shown that the Δ of the gelatin filtrate from serum is reduced by at most 0.035°C . The concentration of the urine may, however, differ from that of the serum by even much more than this quantity. The smallest Δ of urine found by Dreser (39) was 0.16°C ; this occurred after drinking one-half litre of Bavarian beer. Von Koranyi (40) states that the Δ of the urine may fall below 0.10°C . No observations of the Δ of the blood were made in these cases, but it is known from other sources that this could certainly not have been reduced to less than 0.45. This gives a difference of 0.35°C , between the Δ of the blood and that of the urine, corresponding to an osmotic pressure of 3140 mm. Hg, which would need to be overcome by the blood-pressure in order that filtration could take place.

I consider that these facts establish that *filtration is not sufficient to account for the phenomena of urine formation*. A vital secretion must be assumed, and I believe this to hold true of all the urinary constituents. In view of this I consider that *the retention of salts depends quite as much upon their non-secretion, as upon their reabsorption*.

Whilst advocating the existence of a vital secretory process, I do not mean to deny that physical processes co-operate to a very important extent in the formation of urine. The kidney cells, especially the cells of Bowman's capsule, must be affected by osmotic processes in much the same manner as other cells. The conditions are particularly favorable to filtration. The dependence of the urine secretion upon the blood flow is well demonstrated; although this dependence could be explained on the secretion theory, an increased circulation must also be a potent aid to filtration.

The importance of filtration becomes particularly great when salts are injected, or when hydræmia is produced; for the former furnish a larger amount of filterable constituents, and the latter causes an increase of the glomerular capillary pressure. A similar coexistence, and variable importance, of a secretion and filtration process may be noted in the intestine. No one doubts that the intestinal epithelium ordinarily *secretes* the intestinal fluid. But when large quantities of saline solution are injected, a fluid is poured into the intestine with a rapidity which can only be explained by filtration. The following may serve as an example:

Experiment VIII: 1500 c.c. of isotonic sodium chloride was injected into the femoral vein of a dog of 3.9 Kg. 1050 of this was recovered from the intestine, and 420 c.c. of this within the first hour.

IX. CONCLUSIONS.

1. The disappearance of chlorides from fever urines is due practically entirely to the deficiency of chloride income. It cannot possess any diagnostic value.

2. The mechanism of the retention of chlorides is not explained by any physical theory, but must be a vital process. Lessened secretion and increased reabsorption are probably both concerned in the retention.

3. The filtration theory of urine formation is inadequate.

X. BIBLIOGRAPHY.

1. F. RÖHMANN: *Zeitschrift für klinische Medicin*, 1879, i, p. 513.
2. REDTENBACHER: *Zeitschrift der kaiserlich-königlichen Gesellschaft der Aerzte zu Wien*, 1850. (Quoted by RÖHMANN.)
3. E. UNRUH: *Archiv für pathologische Anatomie*, 1869, xlviii, p. 227.
4. J. P. LANGLOIS and CH. RICHEL: *Journal de physiologie et de pathologie générale*, 1900, ii, p. 742.
5. J. FORSTER: *Zeitschrift für Biologie*, 1873, ix, p. 297.
6. Gramatchikov: Inaugural Dissertation, St. Petersburg, 1890 (Russian). Quoted in "Digest of Metabolism Experiments," ATWATER and LANGWORTHY, *Bulletin* 45, Office of Experiment Station, United States Department of Agriculture, 1898.
7. LAUDER-BRUNTON: "Text-book of Pharmacology, etc.," Philadelphia, 1885, p. 503. The statement appears to be based on the experiments of VOIT (RÖHMANN, p. 520).
8. O. KRUMMACHER: *Zeitschrift für Biologie*, 1900, xl, p. 173.
9. A. KAST: *Zeitschrift für physiologische Chemie*, 1888, xii, p. 267.
10. M. SCHUBERT: "Ueber den Stickstoff und NaCl Umsatz während der Bildung und nach der Punktion des Ascites bei Lebercirrhose," Inaugural Dissertation, Breslau, 1895.
11. WALDVOGEL: *Archiv für experimentale Pathologie*, 1901, xlvi, p. 41.
12. KOBLER, VOGEL, and HUSCHE: Quoted by LINDEMANN (13, p. 25).
13. L. LINDEMANN: *Deutsches Archiv für klinische Medicin*, 1899, lxxv, p. 1.
14. STICHER and MARKWALDT: Quoted by KAST.
15. SCHÖPP, 1892: Quoted by ATWATER and LANGWORTHY.
16. FALCK: "Handbuch der diätätischen Heilmittellehre," p. 128, etc. Quoted by FCH. MÜLLER, Inaugural Dissertation, Marburg, 1872.
17. BIDDER and SCHMIDT: Quoted by FORSTER.
18. C. F. HOOVER and T. SOLLMANN: *Journal of experimental medicine*, 1897, ii, p. 405.

19. A. CAHN : Zeitschrift für physiologische Chemie, 1886, x, p. 522.
21. R. MAGNUS : I. Archiv für experimentale Pathologie, 1900, xliv, p. 68; II. *Ibid*, p. 396. III. *Ibid*, xlv, p. 210. IV. GOTTLIEB and MAGNUS, *Ibid*, xlv, p. 223. V. *Ibid*, p. 248.
22. T. SOLLMANN : Archiv für experimentale Pathologie, 1901, xlvi, p. 1.
23. A. R. CUSHNY : Journal of physiology, 1902, xxvii, p. 429.
24. BERGMANN : Archiv für experimentale Pathologie, 1901, xlvi, p. 77.
25. I. MUNK : Archiv für pathologische Anatomie, cvii, p. 291; cxI, p. 434.
26. NUSSBAUM : Archiv für die gesammte Physiologie, 1878, xvii, p. 580.
27. A. P. BEDDARD : Journal of physiology, 1902, xxviii, p. 20.
28. K. SPIRO : Archiv für experimentale Pathologie, 1898, xlvi, p. 148.
29. K. KATSUYAMA : Zeitschrift für physiologische Chemie, 1901, xxxii, p. 235.
30. C. J. MARTIN, Journal of physiology, 1896, xx, p. 364.
31. E. H. STARLING, Journal of physiology, 1899, xxiv, p. 317.
32. WAYMOUTH REID : Journal of physiology, 1901, xxvii, p. 161.
33. ST. BUGARSZKY and L. LIEBERMANN : Archiv für die gesammte Physiologie, 1898, lxxii, p. 51.
34. T. SOLLMANN : This journal, 1902, vii, p. 203.
35. B. MOORE and W. H. PARKER : This journal, 1902, vii, p. 261.
36. A. R. CUSHNY : This journal, 1901, vi, p. xvii.
37. I. MUNK and SENATOR : Archiv für pathologische Anatomie, 1888, cxviii, p. 1.
38. FR. V. KORANYI : Zeitschrift für klinische Medicin, 1897, xxxiii, p. 1, 1898, xxxiv, p. 1.
39. DRESER : Archiv für experimentale Pathologie, 1892, xxix, p. 303.
40. FR. V. KORANYI : Berliner klinische Wochenschrift, 1899, xxxvi, p. 782.
41. C. POTOTZKY : Archiv für die gesammte Physiologie, 1902, xci, p. 584. (The series of articles by FILEHNE and his pupils, of which this paper is a part, appeared some time after the present paper was ready for the press. It was therefore impossible for me to discuss them as fully as they deserve.)

DOES POTASSIUM CYANIDE PROLONG THE LIFE OF THE UNFERTILIZED EGG OF THE SEA-URCHIN?

BY F. P. GORHAM AND R. W. TOWER.

[*From the Anatomical Laboratory, Brown University, and the Scientific Laboratory of the U. S. Fish Commission, Woods Hole, Mass.*]

INTRODUCTION.

IN a recent paper by Loeb and Lewis¹ on the "Prolongation of the Life of the Sea-Urchin Egg by Potassium Cyanide," the statement was made that "there are two kinds of processes going on in the egg: one which leads to the death and disintegration of the egg, — a mortal process; and a second, which leads to cell divisions and further development. The latter process inhibits or modifies the mortal process. . . . According to this idea, death and disintegration are due to specific processes which take place in the egg and possibly in other or all living matter. These processes must be checked in order to render life possible." They consider these processes to be chemically catalytic phenomena, and that consequently any agency which could stop or retard the catalytic action, without injuring the living matter, would of necessity check the mortal process. And they state that "among all the agencies which act in this way, potassium cyanide seemed to meet this condition most perfectly. It weakens or inhibits a number of enzymatic processes in living matter without necessarily altering the constitution of the latter. When the potassium cyanide is permitted to evaporate, the original condition of the system may be restored."

In the main, Loeb and Lewis found that eggs kept in normal sea-water could not be fertilized after forty-eight hours. After this time the eggs "became a sticky mass and assumed a dirty brownish color, and this was the beginning of complete disintegration and putrid decay." But if the eggs were put into a solution of $\frac{1}{1000}$ KCN for seventy-two hours, then removed to normal sea-water and fertilized, they would develop in every case into plutei. In some instances

¹ LOEB and LEWIS: This journal, 1901, vi, p. 305.

plutei were obtained from eggs that had been in the poisoned sea-water from ninety to one hundred hours, or about four days, while those that had remained for five days developed only to the four-cell stage.

In Loeb's experiments the dishes were loosely covered, and consequently the potassium cyanide solutions containing the eggs were constantly growing weaker. If, on the other hand, the evaporation was prevented by complete closure of the dishes, the eggs were so affected that after an exposure of sixty-six hours only a few of the eggs were able to segment when fertilized. For the detailed experiments the reader is referred to the original article.

Upon reading the above paper, the authors of the present article concluded that many of the deductions were not warranted by the results of the experiments described, and that other interpretations were both possible and logical. There seemed to be nothing to show whether the potassium cyanide was acting directly on the living matter of the egg, or was producing some change in the external environment which in its turn affected the egg. Could it not be possible that the potassium cyanide solutions prolong life only because they kill the bacteria that ordinarily cause the egg to die?

The fact that the potassium cyanide solution which Loeb found most favorable for prolonging the life of the egg is strongly antiseptic is important in this connection. Solutions of greater strength kill the egg, while weaker solutions are not so effective in prolonging its life.

The fact, too, that the optimal solution of potassium cyanide acts beneficially only when allowed to become gradually weaker, does not prevent us from thinking that after all the potassium cyanide is slowly killing the egg, and is beneficial only because it acts on the bacteria before it does on the egg itself.

It seemed also that there might be other factors at work which had been overlooked by Loeb and Lewis. In order to convince ourselves of the facts, we repeated, as closely as possible, Loeb's experiments, first upon the eggs of the winter-flounder, and then upon the eggs of the sea-urchin. Experiments to determine the antiseptic value of the potassium cyanide solutions used by Loeb were also made.

ANTISEPTIC VALUE OF THE POTASSIUM CYANIDE SOLUTIONS.

In the preliminary experiments, to test the antiseptic value of the potassium cyanide solutions, it was found that the addition of potassium cyanide to salt-water, so that the resulting solution was $\frac{1}{1000}$

KCN, reduced the number of bacteria from some 3,000,000 per c.c. to about 2,000 in twenty-four hours, while a $\frac{1}{500}$ solution reduced the number to about 1,000 in the same time.

EXPERIMENTS ON EGGS OF THE WINTER-FLOUNDER (*Pseudopleuronectes americana*).

The ova of this animal are not adapted to the study of fertilization and segmentation, but were all that were available in March, when these experiments were undertaken. The experiments of Loeb were repeated on the eggs of the flounder, and the number of bacteria in the different solutions was determined at various periods.

The protocol of these experiments follows:—

TABLE I.

Solutions.	Number of bacteria in each c.c. when eggs were added.	Number of bacteria in each c.c. after 27 hours.	Number of bacteria in each c.c. after 48 hours.
Salt-water	700	..	Countless.
Salt-water containing eggs	500	150,000	Countless.
Salt-water containing sperm	460,000	Countless.
Salt-water containing fertilized eggs	460,000	Countless.
$\frac{1}{4000}$ KCN containing eggs	400	180	39,500
$\frac{1}{2000}$ KCN containing eggs	45	90
$\frac{1}{1000}$ KCN containing eggs	36	32
$\frac{1}{750}$ KCN containing eggs	65	25	..
$\frac{1}{750}$ KCN containing fertilized eggs	25	5
$\frac{1}{400}$ KCN containing eggs	21	8	..
$\frac{1}{300}$ KCN containing eggs	0	0
$\frac{1}{250}$ KCN containing eggs	0	0
$\frac{1}{200}$ KCN containing eggs	13	0	0

From the above table we notice:

1. The enormous number of bacteria in the salt-water containing the eggs and sperm.

2. The number of bacteria is reduced by the addition of potassium cyanide in proportion to the strength of the solutions.

3. The decrease in numbers does not continue after the first few days, particularly in the weaker solutions. This is doubtless due to the gradual loss of potassium cyanide.

EXPERIMENTS ON THE EGGS OF THE SEA-URCHIN (*Arbacia punctulata*).

The experiments of Loeb and Lewis were carefully repeated. Analyses were made of the various solutions to determine the number of bacteria present. Control experiments were made in every case and all the conditions prescribed by Loeb were carefully followed. After one complete set of experiments was carried through, all the solutions were destroyed, a new $\frac{1}{10}$ KCN solution was prepared, and the entire experiment was repeated. The results of the two experiments were found to be identical in every particular, and are given in Table II.

On the whole the results agree with those of Loeb with the exception that our $\frac{2}{1000}$ and $\frac{4}{1000}$ KCN solutions preserved the eggs the longest, while Loeb found the $\frac{7}{50}$ and $\frac{1}{1000}$ the most potent. This discrepancy may be due to a difference in the purity of the potassium cyanide salt used. In our case a quantitative analysis showed it to contain ninety per cent potassium cyanide.

In our experiments the most favorable results were obtained at the end of ninety-six hours, while Loeb reports seventy-five hours as the optimal time. This seems to indicate that some other factor than potassium cyanide is at work. The number of bacteria present in the various solutions at the end of ninety-six hours, as shown by the table, is in proportion to the concentration of the potassium cyanide. The stronger solutions are sterile.

PROTOZOA.

During the above experiments it was noticed that under the same conditions more bacteria appeared at one time than at another. Further investigation showed that there were present also varying numbers of protozoa. The relation of these organisms to the life of the sea-urchin larvæ can be seen in Table III.

It is evident that when the protozoa are numerous the life of both eggs and larvæ is preserved. The protozoa destroy enormous numbers of bacteria. Wherever there are large numbers of protozoa there are

TABLE II.

Solutions. 240 c.c. in each dish + 5 c.c. of eggs.	24 hours.	48 hours.	72 hours.	96 hours.
(Control) Sea-water. 1000 bacteria per c.c.	600,000 bacteria per.c.c. Eggsfer- tilized, and de- velop normally into plutei. Of the unfertilized eggs none devel- ops.	390,000 bacteria per.c.c. Feweggs segment irregu- larly in first ex- periment. Insec- ond experiment no egg develops.	17,000 bacte- ria per c.c. No egg seg- ments. A sticky, putrid mass.	850,000 bacteria per c.c. No egg segments.
$\frac{1}{32000}$ KCN	Same as control. Develop into plutei.	No egg segments.	No egg seg- ments.	No egg segments.
$\frac{1}{16000}$ KCN	Same as control.	No egg segments.	No egg seg- ments.	950,000 bacteria per c.c. No egg segments.
$\frac{1}{8000}$ KCN	Same as control.	50 per cent of eggs segment and de- velop to swim- ing larvæ.	Some eggs seg- ment and de- velop to plu- tei.	800,000 bacteria per c.c. No egg segments.
$\frac{1}{4000}$ KCN	Nearly all segment and develop to swimming larvæ.	Most segment and develop to swim- ing larvæ. Some irregularly.	Very few seg- ment.	550,000 bacteria per c.c. All seg- ment and de- velop to swim- ing larvæ.
$\frac{1}{2000}$ KCN	Nearly all segment and develop to swimming larvæ.	No egg segments.	Very few seg- ment.	380,000 bacteria per c.c. Most segment and de- velop to swim- ing larvæ.
$\frac{1}{1000}$ KCN	Nearly all seg- ment and few develop to swim- ing larvæ.	Many segment. Some irregu- larly.	No egg seg- ments.	35,000 bacteria per c.c. No egg seg- ments.
$\frac{1}{750}$ KCN	Nearly all seg- ment. Some ir- regularly. Few larvæ.	No egg segments.	No egg seg- ments.	11,000 bacteria per c.c. No egg seg- ments.
$\frac{1}{400}$ KCN	Few segment ir- regularly. Very few larvæ.	No egg segments.	No egg seg- ments.	No bacteria. No egg segments.
$\frac{1}{300}$ KCN		No egg segments.	No egg seg- ments.	No bacteria. No egg segments.
$\frac{1}{250}$ KCN	No egg segments.		No egg seg- ments.	No bacteria. No egg segments.

few bacteria. Here again the beneficial action on the eggs or larvæ is due to the elimination of bacteria. To test the accuracy of this deduction a special experiment was made to determine more exactly the ability of the protozoa to free a solution from bacteria and thus preserve the life of eggs or larvæ.

A solution was taken containing developing eggs which were being destroyed rapidly by large numbers of bacteria. This was inoculated with a considerable number of protozoa. Within twenty-four hours the bacteria had eaten up the dead embryos, the protozoa had greatly reduced the number of bacteria, and the larvæ which had survived during the struggle were alive and swimming actively. In the control experiments all the larvæ were dead.

TABLE III.

Solution in which eggs were kept.	Number of days after fertilization.	Condition of larvæ.	Number of protozoa.
Sea-water	6	Dead	None.
$\frac{1}{32000}$	5	Few swimming	Many.
$\frac{1}{16000}$	4	Alive	Many.
$\frac{1}{8000}$	4	Swimming	Very many.
$\frac{1}{4000}$	5	All alive	Very many.
$\frac{1}{4000}$	5	All dead	None.
$\frac{1}{2000}$	4	All dead	None.
$\frac{1}{2000}$	6	Swimming	Many.
$\frac{1}{1000}$	4	Dead	None.

The relation of bacteria to protozoa in standing sea-water is well shown in the two experiments of Table IV.

TABLE IV.

Number of hours.	Bacteria per c.c.	Protozoa per 5 c.c.	Number of hours.	Bacteria per c.c.	Protozoa per 5 c.c.
0	1,000	1 or 2.	0	1,800	1 or 2.
24	25,500	1 or 2.	24	600,000	8 to 10.
48	120,000	5	48	390,000	Numerous.
72	120,000	10 to 20.	72	17,000	Very numerous.
96	2,300	Numerous.			
120	1,600	Very numerous.			

EXPERIMENTS WITH STERILE SEA-WATER.

In order to determine whether the preservation of the life of the egg is due to the direct action of the potassium cyanide on the egg, or to the antiseptic action of the potassium cyanide whereby the injurious action of bacteria is eliminated, experiments of another kind were made in which potassium cyanide did not figure, and in which no bacterial contamination was possible.

The ideal experiment of this kind would be to place the sterile eggs of the sea-urchin in sterilized sea-water and to remove a few on successive days for fertilization. It was found possible to collect the eggs from the sea-urchin in a perfectly sterile condition and to transfer them to sterilized sea-water, where they were kept for eleven days at laboratory temperature uncontaminated by bacteria. The accompanying data, Table V, gives the results of an experiment of this kind.

TABLE V.

Number of days before fertilization.	1 day.	2 days.	3 days.	4 days.	5 days.	7 days.	11 days.
Sterile eggs in sterile sea-water.	Develop into plutei.	Develop into plutei.	Develop into plutei.	Develop into plutei.			
Sterile eggs in ordinary sea-water.	Develop into plutei.	Few eggs segment.	No egg segments.	Eggs are now a putrid mass.			
Ordinary eggs in ordinary sea-water.	Develop into plutei.	No egg segments.	No egg segments.	Eggs are now a putrid mass.			

As will be seen, the sterile eggs that were kept in the sterile sea-water for eleven days could at any time be fertilized and would develop into normal plutei; while in all cases, eggs that were not kept sterile died in about forty-eight hours. At the end of eleven days, all the sterile eggs were alive. How much longer they would live, was not determined. Thus, by preserving the sterile condition of the eggs, their life has been "prolonged" nearly four times as long as when treated with potassium cyanide solutions.

It seems probable, therefore, from a consideration of these experiments, that potassium cyanide acts always as a poison; that any supposedly beneficial action is due entirely to its antiseptic properties.

CONCLUSIONS.

1. The action of potassium cyanide is only an indirect one, *i. e.* killing or inhibiting the bacteria, and thus giving the eggs a more favorable environment.
2. In all experiments with unsterilized sea-water, the protozoa enter as an important bacteria-destroying factor which must be considered in interpreting the results.
3. Sterile sea-water "prolongs" the life of the egg of the sea-urchin much longer than Loeb's most favorable potassium cyanide solutions.
4. Both our own experiments and those of Loeb show that too strong solutions of potassium cyanide, and too long exposure to weak solutions, soon kill the egg. From this the reasonable interpretation is, that the potassium cyanide is a poison for all living matter, but it acts more quickly on bacteria than on sea-urchin eggs; it is in no sense a prolonger of life.
5. From the fact that unfertilized eggs can be kept in sterile sea-water for eleven days or longer, it would seem that the specific mortal processes of Loeb are as yet hypothetical phenomena without any definite experimental basis.

We are indebted to the United States Fish Commission for extending the courtesies of their Scientific Laboratories at Woods Hole.

NOTES ON THE "PROTAGON" OF THE BRAIN.¹

BY W. W. LESEM AND WILLIAM J. GIES.

SEVERAL years ago Chittenden and Frissell² made a study of the distribution of phosphorus-containing substances in the brain. The results obtained by them seemed to "indicate that protagon contains but a small proportion of the total phosphorus of the brain and that other phosphorized organic bodies, such as lecithins, are present, preformed in the tissue, in relatively large proportion." They concluded that "the dry solid matter of the brain contains as much or even more lecithin than protagon." Chittenden and Frissell also observed that, "contrary to previous statements, protagon tends to undergo cleavage by long-continued heating at 45° C. in 85 per cent alcohol, a certain amount of an alcohol-soluble (at 0° C.) body richer in phosphorus than protagon, being split off while the residual protagon obtained by recrystallization at 0° C. contained a somewhat diminished percentage of phosphorus."

Shortly after the publication of the brief note containing the above deductions, Dr. Gies repeated and extended the experiments begun by Dr. Frissell. The general conclusions of this second series of experiments were practically the same as those previously reported, but as the work was unavoidably interrupted, no further reference was made to them. Recently, however, new experiments on protagon have been performed by Mr. Lesem and Dr. Gies. The results of these experiments, to which we shall refer farther on, make it seem desirable to give here some of the related data of the earlier experiments in which the work of Chittenden and Frissell was repeated.

¹ This work was begun by Dr. GIES under Professor CHITTENDEN'S supervision, in the Sheffield Laboratory of Physiological Chemistry at Yale University. It was completed by Mr. LESEM and Dr. GIES in the Laboratory of Physiological Chemistry at Columbia University.

² CHITTENDEN: Proceedings of the American Physiological Society, Science, 1897, v. (N. S.), p. 901.

I. ON THE GENERAL DISTRIBUTION OF PHOSPHORUS-CONTAINING SUBSTANCES IN THE BRAIN.

The brains employed in the experiments by Chittenden and Frissell were taken from sheep. Although the brains were used within twenty-four hours after the death of the animals, it seemed possible that, even within that short period, bacterial changes might have had some influence on the results.¹ In repeating the first series of experiments, this difficulty was obviated by the adoption of the following procedure, which is the same as that used by Chittenden and Frissell,² except in the steps taken at the beginning to prevent possible alterations through the influence of bacteria.

First experiment. — In this experiment glass-stoppered bottles of convenient size, containing about 750 c.c. of 85 per cent alcohol, were accurately weighed and removed to the slaughter house without loss of fluid. The sheep were killed in the usual way. The greater portion of blood disappeared from the brain in a minute or two, when the head was opened with a cleaver and the entire brain quickly removed. Superficial blood and lymph were taken off promptly with a clean dry cloth. While the brains were still at practically the normal body temperature, they were rapidly slashed with a scalpel and at once transferred to the bottled alcohol. Two whole brains were deposited in each of three bottles. Special care was taken to prevent any loss of alcohol by evaporation or by spilling.

It would seem that this prompt treatment with alcohol prevented such post-mortem changes as exposure for several hours to the air, a lowered temperature, etc., might induce. We do not mean to suggest, however, that the alcohol itself has no transforming power on the phosphorized constituents. Such influence, if exerted, would doubtless have been no greater, nor any different, at this point than later on.

The quantities of tissue in each bottle were 152.99, 172.19, and 148.89 gms.

Preliminary cold extracts. — The tissue remained in the original alcohol about four hours, when the filtrate was collected and the tissue very thoroughly macerated in a mortar. The finely divided material was next transferred to 750 c.c. of 85 per cent alcohol, and kept under it over

¹ The results of the following experiments show, however, that no appreciable changes of such character could have been effected.

² The methods employed by CHITTENDEN and FRISSELL could not be described in the very brief abstract of the preliminary report of their work. For that reason we give the methods here in some detail.

night, after which the filtrate was again separated. These two cold extracts were combined.

Extracts at 45° C.—Extraction was next made in 85 per cent alcohol (1½ litres for each pair of brains) for ten hours at 45° C., and the filtrate again collected. After standing in 2 litres of 85 per cent alcohol, at room temperature over night, the alcohol-tissue mixture was warmed to 45° C. and held at that temperature for twelve hours, after which the filtrate was again obtained. The residual tissue was once more kept in 2 litres of 85 per cent alcohol over night and further extracted in the same fluid at 45° C. for fourteen hours, when the filtrate was preserved as before. After each of these filtrations, the solid substance was washed with a little warm alcohol (85 per cent), and the washings added to the appropriate filtrate.

Extraction in boiling alcohol.—At this point the tissue remained in 1 litre of 85 per cent alcohol over night, when the mixture was boiled on a water bath for a half hour. After filtering, the tissue was also extracted in boiling 95 per cent alcohol for the same length of time. These two hot alcoholic extracts were combined.

Tissue residue.—The residual tissue was finally washed with cold 95 per cent alcohol, then with absolute alcohol, and dried to constant weight at 80° C.

Treatment of the extracts.—The extracts obtained at room temperature and in boiling alcohol were separately evaporated in silver crucibles almost to dryness, and the total phosphorus content determined directly. The cold extract of our first preparation, however, was separated into protagon and filtrate therefrom by the method referred to below.

The three extracts obtained at 45° C., in the second and third preparations, were separately reduced to 0° C. with the aid of common freezing mixture, and held at that point for six hours. A heavy flocculent precipitate containing much crystalline cholesterin, protagon, etc., quickly separated from the first of each series of three extracts. The precipitate was considerably less in the second extract, and only a very faint turbidity was formed in the third. Each precipitate was quickly filtered, at a temperature slightly below 0° C., on funnels surrounded by freezing mixture. The precipitates were washed once with cold 85 per cent alcohol, and then with cold ether until free from cholesterin. The alcohol washings were added to the same filtrates. The filtrates were combined and evaporated for the determination of phosphorus. The ether washings were given the same treatment. The protagon products were dried at a low temperature on the filter papers. Phosphorus was determined in the mixture of protagon and filter papers, the latter having been free from that element.

Phosphorus was always determined by the usual fusion method.

Analytic results. — The following table gives our analytic results for phosphorus in the various solids and fluids separated by the above method :

TABLE I.

Extracts, etc.	Phosphorus content.						
	I.	II.	III.	II.	III.	II.	III.
	Grams.			Percentage of total solid matter.		Percentage of total phosphorus.	
A. Cold extracts (2)	0.1423	0.1348	0.1841	0.35	0.43	26.32	32.33
<i>a.</i> Protagon	0.0432						
<i>b.</i> Filtrate from protagon	0.0991						
B. Extracts at 45° C. (3)	0.2599	0.2887	0.68	0.67	51.14	50.38
<i>a.</i> Protagon	0.0874	0.1008	0.23	0.23	17.30	17.30
<i>b.</i> Filtrates from protagon	0.1370	0.1401	0.36	0.33	27.07	24.81
<i>c.</i> Ether washings of protagon	0.0355	0.0478	0.09	0.11	6.77	8.27
C. Extracts in boiling alcohol	0.0047	0.0054	0.01	0.01	0.75	0.75
D. Tissue residue	0.1098	0.0939	0.29	0.22	21.80	16.54
Total phosphorus	0.5092	0.5721	1.33	1.33		
Weight of fresh tissue	148.89	152.99	172.19				
Weight of tissue residue	15.25	17.08				
Estimated solids in fresh tissue (25 per cent)	38.25	43.05				
Estimated weight of extracted matter	23.00	25.97				

That the preliminary cold extracts contained a comparatively small amount of protagon seems to be indicated by the results for our first preparation. Protagon is only slightly soluble in 85 per cent alcohol at 0° C., and is practically insoluble in ether at the same temperature. Thus of 2 grams of protagon, 0.03 to 0.04 gram dissolved in 500 c.c. of 85 per cent alcohol at 0° C. The same quantity of ethereal filtrate from 3.6 grams of protagon, at the same temperature, contained nothing yielding a phosphorus reaction after fusion with alkali. It is possible that the presence of the other constituents of the alcoholic extract may increase or decrease this solubility. It is hardly probable, however, that more than an insignificant portion

of the protagon remains unprecipitated on lowering to zero the temperature of alcoholic extracts such as the above.

Second experiment. — We decided to repeat the experiment again, but with less tissue. The results of our previous experiment had been obtained for the whole brain. We now endeavored to ascertain whether the above data apply equally to all portions of the brain or whether there are wide phosphorus variations for the parts. This was accomplished indirectly without materially altering the conditions of the previous experiment. For the purpose indicated we took amounts of tissue equivalent in weight to a whole brain, but made up of different parts of two brains.

The method of treatment at the slaughter house, transportation in weighed alcohol, extraction in 85 per cent alcohol at room temperature, at 45° C., etc., separation of protagon, etc., were the same in this as in the first experiment. Samples of the fresh tissue were used for determinations of solids and phosphorus.

At the slaughter house the brains were carefully sectioned transversely into halves just before their deposition in the alcohol. The halves were combined as indicated in the next table. The preliminary extracts in cold alcohol were united with those obtained at 45° C., and the protagon was removed from the mixture. Four extractions of each sample of tissue were made at 45° C. One litre of 85 per cent alcohol per brain was used each time. The washing of the protagons with ether was omitted.

Table II, on page 188, gives the essential results of this experiment.

Only insignificant differences are to be observed between the results of the first two experiments. The analytic data are, therefore, essentially the same for the anterior and posterior halves of the brain. The similarity of the results of this series to those of the preceding is especially evident from the directly comparable data given in Table III on page 188.

The results of the first and second experiments show that the greater portion of the phosphorus of the brain is contained in substances not precipitable as protagon. The bulk of the phosphorus in the preliminary cold extract (Exp. 1), and in the filtrates from the protagons (Exps. 1 and 2), is doubtless contained in substances as readily soluble in alcohol as lecithin. Some phosphate was also present. Probably most of the phosphorus of the ether washings (Exp. 1) was contained in substance which was soluble in the

The results of the next experiment lead to essentially the same conclusions as those drawn from the preceding.

Third experiment.—The methods of this experiment were, in general, the same as those of the first and second. The following differences of treatment are to be noted. The divisions of the brains were made longitudinally instead of transversely. The alcoholic filtrates (2), obtained at 0° C. after separation of the protagon, were evaporated almost to dryness on a water bath at 35–40° C. The residues thus resulting were thoroughly extracted several times with a moderate excess of cold ether. The extracts were filtered and evaporated to dryness. The residue left after treatment with ether was extracted with boiling 95 per cent alcohol. So little seemed to dissolve that the alcoholic extracts were evaporated with the ethereal. The substance remaining after the extraction with alcohol, mostly inorganic matter, was next treated with water. All of it dissolved very readily. This solution was then evaporated to dryness. Phosphorus was determined in the substance from each of these extracts and in the protagon, with the results tabulated below :

TABLE IV.

Extracts, etc.	Phosphorus content.		
	A. Same lateral halves of brains 1 and 2. Grams.	B. Opposite lateral halves of brains 1 and 3. Grams.	C. Opposite lateral halves of brains 4 and 5. Grams.
I. Protagon (2)	0.0576	0.0701	0.0667
II. Filtrates	0.1725	0.1841	0.2037
<i>a.</i> Substance soluble in alcohol and ether	0.1531	0.1603	0.1750
<i>b.</i> Residual substance soluble in water	0.0194	0.0238	0.0287
Total phosphorus	0.2301	0.2542	0.2704
Weight of fresh tissue	89.46	104.50	102.50

II. ON THE QUESTION OF THE CHEMICAL INDIVIDUALITY OF PROTAGON.

Twenty years ago Gamgee expressed himself on this subject as follows : " There is no subject in physiological chemistry concerning which it is more difficult to give a statement, which would be accepted

as correct by those who have devoted their attention to it, than the chemistry of the complex phosphorized fats which exist in the nervous tissue."¹ The same may be said perhaps with equal force to-day, in spite of the careful work done in the mean time to solve the problems connected with the chemical constituents of the brain.

Soon after Liebreich² separated from the brain the substance he called protagon, Thudichum³ and others denied the existence of such a substance. Thus, Diaconow,⁴ working as did Liebreich, in Hoppe-Seyler's laboratory, obtained results which led him to conclude that protagon is a mixture of lecithin and cerebrin. The later researches of Gamgee and Blankenhorn,⁵ however, furnished data which were generally accepted as amply confirming the original conclusions of Liebreich. The subsequent work of Baumstark,⁶ Kossel and Freytag,⁷ and Ruppel,⁸ particularly, further emphasized the growing confidence in the existence and importance of protagon as a brain constituent. Until recently the matter seemed to be settled in the general conviction that protagon is a chemical individual, in spite of Thudichum's claims to the contrary. As late as 1899 Hammarsten⁹ indicated, as follows, the prevalent feeling toward the non-concurrent conclusions in which Thudichum has persisted: "Thudichum claims to have isolated from the brain a number of phosphorus-containing substances which he divides into three main groups: kephalins, myelins, and lecithins. Thus far, however, his results have not been confirmed by any other investigators."

The work of Kossel and Freytag may be regarded as an approach to Thudichum's position with reference to the composite nature of protagon. Kossel and Freytag discovered that protagon contains sulphur. Variations among their several products, in spite of great care in preparation, also led them to believe in the existence of several protagons. Further than this, they found that protagons

¹ GAMGEE: A text-book of the physiological chemistry of the animal body, 1880, i, p. 425.

² LIEBREICH: *Annalen der Chemie und Pharmacie*, 1865, cxxxiv, p. 29.

³ THUDICHUM: *Chemisches Centralblatt*, 1875, p. 408.

⁴ DIACONOW: *Centralblatt für die medicinischen Wissenschaften*, 1868, p. 97.

⁵ GAMGEE UND BLANKENHORN: *Zeitschrift für physiologische Chemie*, 1879, iii, p. 260.

⁶ BAUMSTARK: *Ibid*, 1885, ix, p. 145.

⁷ KOSSEL UND FREYTAG: *Ibid*, 1893, xvii, p. 431.

⁸ RUPPEL: *Zeitschrift für Biologie*, 1895, xxxi, p. 86.

⁹ HAMMARSTEN: *Lehrbuch der physiologischen Chemie*, 1899, p. 366.

readily yield several substances similar to or identical with some described by Thudichum,¹ and which he still contends are among the fourteen (!) different bodies contained in the protagon mixture. The subsequent work of Chittenden and Frissell also gave indications of facts in harmony with the earliest results of Diaconow and his view that protagon is a mixture. Lately, Wörner and Thierfelder² attacked the problem by improved methods, and obtained results which seem to show that protagon is not an individual substance, or else that it is a remarkably labile body, physically and chemically.

Below we give the results of our repetitions of the experiments of Chittenden and Frissell bearing on the matter in question.

Fourth experiment.—A sample of protagon which had been prepared by Dr. Frissell from sheep brains by the usual method — precipitation from warm alcoholic extract at 0° C. and thorough washing in ether at 0° C. — was placed at our disposal for this experiment.

We further purified the protagon by recrystallizing it once from alcohol. 25 gms. of the product was kept in 1500 c.c. of 85 per cent alcohol at 40° C. for twelve hours and the mixture repeatedly stirred. At the end of that time only about half of the substance had dissolved.

First product and filtrate. — The mixture was filtered and the protagon separated from the extract by the usual cooling process, etc. The filtrate from the protagon was evaporated to dryness.

Second product and filtrate. — That portion of the original protagon which remained undissolved was again subjected to treatment in the same amount of alcohol. Most of the substance dissolved at the end of twelve hours. The second portions of protagon and evaporated filtrates were obtained as before from the filtered extract.

Third product and filtrate. — The protagon still remaining undissolved after the second extraction with alcohol was again placed in the same amount of warm alcohol for a similar period. Protagon was separated from the extract and the filtrate from it evaporated to dryness as before.³

Insoluble portion. — A fairly large proportion of the original protagon remained insoluble under these conditions.

Alcohol-ether washings. — Each successive residual portion of protagon referred to above was washed with warm alcohol and the washings added to

¹ THUDICHUM: Die chemische Konstitution des Gehirns des Menschen und der Tiere, 1901, pp. 54-57; 328.

² WÖRNER UND THIERFELDER: Zeitschrift für physiologische Chemie, 1900, xxx, p. 542.

³ The crystalline appearance of these various protagon products was practically the same.

the filtrates. All of the samples of freshly precipitated protagon were washed first with a small quantity of cold 85 per cent alcohol and later with moderate excess of cold ether. The alcoholic and ethereal washings of the freshly precipitated protagon were combined and evaporated. *Treatment of the products.* — The portions of protagon, and the substance in the filtrates and washings, were carefully determined quantitatively. Phosphorus was also estimated in each by the usual fusion method.

The following summary gives our data in this connection: —

TABLE V.

Protagon, etc.	Weight in grams. ¹	Percentage of phosphorus.
<i>A.</i> Freshly precipitated protagon:		
<i>a.</i> From first extract	10.834	1.23
<i>b.</i> From second extract	7.599	0.89
<i>c.</i> From third extract	1.729 (20.162)	0.57
<i>B.</i> Insoluble protagon (residue) . . .	2.009	0.12
<i>C.</i> Substance in filtrates from the freshly precipitated protagon:		
<i>a.</i> Of first extract	0.785	2.59
<i>b.</i> Of second extract	0.678	1.31
<i>c.</i> Of third extract	0.250 (1.713)	0.85
<i>D.</i> Alcohol-ether washings of the freshly precipitated products	0.282	2.02
Total substance recovered	24.17	
Total substance taken	24.34	1.16

¹ The weights are for substance dried in vacuo over H₂SO₄ to constant weight.

Fifth experiment. — We repeated the preceding experiment with two freshly prepared samples of protagon made by us from two different quantities of sheep brains. These samples of protagon were prepared by the usual method and were twice recrystallized. Twelve gms. of each was used. Two treatments were made with 1½ litres of 85 per cent alcohol at 45° C., etc., as in the fourth experiment, with the results tabulated on page 193:

Among the points to be noted in Tables V and VI is the decreasing percentage content of phosphorus in each successive protagon and in the final insoluble residue. Also, the unusually high though diminishing proportion of phosphorus in the substance of the filtrates obtained each time protagon was separated at 0° C.

Our method of fractional separation was that customarily employed in the purification of protagon. Here it was merely repeated more frequently than usual. Instead of obtaining purer protagons in the process, however, it appears that, with each successive precipitation, the substance itself changed in composition and, also, that variously composed products were liberated into the filtrates from the protagons at the same time. The final residue was wax-like and quite different from the snow-white protagon of the first extracts. We are certain that our products were "pure" at the start.

TABLE VI.

Protagon, etc.	I.		II.	
	Weight in grams.	Percentage of phosphorus.	Weight in grams.	Percentage of phosphorus.
A. Freshly precipitated protagon: ¹				
<i>a.</i> From first extract . . .	5.945	1.21	3.659	1.19
<i>b.</i> From second extract . . .	2.680 (8.625)	1.01	2.009 (5.668)	1.11
B. Insoluble protagon (residue) .	0.655	0.91	3.892	1.18
C. Substance in filtrates from the freshly precipitated protagon:				
<i>a.</i> Of first extract	1.613	2.22	1.321	1.80
<i>b.</i> Of second extract . . .	0.983 (2.596)	1.30	0.981 (2.302)	1.45
Total substance recovered ² .	11.876	11.862	
Total substance taken . . .	12.150	1.26	12.150	1.23

¹ The precipitates were washed only with cold alcohol.
² See note 1 in the preceding table.

The data of the last two experiments are in close agreement with the similar facts found by Chittenden and Frissell. They are in harmony with corresponding data recently published by Thudichum.¹

These results were obtained by applying the usual purification method. They show, we think, that protagon is either a mixture of bodies, or else a substance decomposing quite readily under the conditions of such experiments. If the latter conclusion appears to

¹ THUDICHUM: Die chemische Konstitution des Gehirns des Menschen und der Tiere, 1901, pp. 84-85.

be more probable than the former, it must then be admitted that thus far no standard of purity for protagon has been raised which is not open to the objection that it is based on methods involving unavoidable decomposition.

Elementary composition of protagon.—It seemed desirable at this point to ascertain the general elementary composition of several of the protagon products prepared in the preceding experiments. The summary below gives our results for four representative preparations :

TABLE VII.

Elements.	Percentage composition of protagons. ¹											
	Fourth experiment.						Fifth experiment.					
	<i>a.</i>			<i>b.</i>			I.			II.		
C	65.98	66.24	66.11	66.63	66.46	66.55	65.87	65.77	65.82	65.54	65.70	65.62
H	10.83	10.97	10.90	10.72	10.60	10.66	10.73	10.47	10.60	10.77	10.91	10.84
N	2.09	1.95	2.02	2.22	2.16	2.19	1.97	1.99	1.98	2.05	2.00	2.03
P	1.23	0.89	1.25	1.26	1.26	1.21	1.25	1.23
S	0.77	0.72	0.67	0.72
O ²	18.97	18.99	19.67	19.56

¹ The methods of analysis employed were those already described by us: HAWK and GIES: This journal, 1901, v, p. 403.

² The amount of ash varied between 2 and 3 per cent. It consisted very largely of phosphate derived during the incineration process.

The results for elementary composition are in fairly close accord with those of previous observers.¹ Since all of our samples were made by practically the same method as that employed in most of the earlier investigations, however, this harmony proves nothing more than that the materials analyzed by all of us were of essentially the same character. The minor variations suggest that the products may be fairly uniform mixtures, but Kossel and Freytag's conclusion that several protagons exist might also be drawn from them. In fact, much to our surprise, these results accord as well as many analytic

¹ See the summary lately given by NOLL: Zeitschrift für physiologische Chemie, 1899, xxvii, p. 376.

series given for what are undoubtedly individual substances. Our data in this connection, considered by themselves, would seem to harmonize with the older view of the integrity of protagon. In the light of our other results, however, they illustrate the fact that uniformity in composition frequently hides chemical differences. In this case general uniformity seems to give no assurance of chemical individuality.

Application of the methods of Wörner and Thierfelder. -- We have repeated some of the recent preliminary experiments of Wörner and Thierfelder without, however, anticipating any of the steps which it may be the intention of these investigators to take in furtherance of their work.

Wörner and Thierfelder used material from human brains. We used purified protagon from sheep brains. The agreement between their results and ours is, therefore, all the more significant. Our data in this connection will be given only briefly.

We made use of freshly prepared protagon, as well as some of the preparations already referred to. Our protagon products dissolved almost entirely in moderate quantities of solutions of equal parts of alcohol and chloroform, or alcohol and benzol, at 45° C. The latter solution appeared to exert solvent action less rapidly than the other. The crystals obtained from such fluids, after gradual evaporation at 40-45° C., varied somewhat with changes in the composition of the solvent and in the concentration of the solution.

The residue left behind at this point, on treatment of the protagon with a moderate quantity of the solution, resembled that remaining in Experiments 4 and 5 preceding. It consisted of globular forms and amorphous substance. On cooling the filtrate from the melted matter, a bulky precipitate of snow-white "cerebron" spheres was deposited. The filtrate from the cerebron, on evaporation, yielded microscopic needles. The filtrate from these crystals contained other organic matter which, however, furnished only a slight amount of crystalline substance on further evaporation or on longer standing. These experiments were repeated several times with similar outcome.

Of these various products the cerebron was the only one we attempted to separate in any quantity for further examination. In all the ordinary tests tried on the several preparations of purified cerebron, we found that our products gave the reactions already attributed to the substance by Wörner and Thierfelder. All the crystals figured for it by these investigators were observed in the

various fluids. The typical transformation of the cerebron balls in 85 per cent alcohol at 50° C. into needles, minute plates, etc., was also brought about several times. We were unable to make any elementary analyses of the cerebron, but verified the statement that on decomposition with acid a reducing substance may be detected among its cleavage products.

In view of these results, also, it appears necessary to conclude that protagon is not merely an unstable substance, but a mixture of bodies.¹ It is not at all likely that these various products arise by decomposition from such mild treatment. Further study of cerebron and its related products, also of the new substance very recently isolated by Ulpiani and Lelli,² and called by them, "paranukleo-protagon," may throw more light on the protagon question.

III. SUMMARY OF GENERAL CONCLUSIONS.

(1) The protagon of the brain is a mixture of substances, not a chemical individual.

(2) The mixture called protagon does not contain the bulk of the phosphorized organic substance of the brain.

¹ See very recent paper by KOCH: *Zeitschrift für physiologische Chemie*, 1902, xxxvi, p. 140.

² ULPIANI UND LELLI: *Chemisches Centralblatt*, 1902, ii, p. 292.

ON THE GROWTH OF SUCKLING PIGS FED ON A DIET OF SKIMMED COW'S MILK.

BY MARGARET B. WILSON.

[From the *Physiological Laboratory of the University and Bellevue Hospital Medical College.*]

THE OLDER EXPERIMENTS.

ABOUT ten years ago at the Yale Medical School Dr. L. C. Sanford and Professor Graham Lusk reared three new-born pigs of the same litter on centrifugalized skimmed cow's milk. To the milk of one pig 2 per cent of milk-sugar was added, to that of a second 2 per cent of dextrose, while a third pig received skim-milk alone. All the pigs had diarrhœa at one time or another, but this did not last long. The experiments proved that the pigs could thrive on a skim-milk diet and that the addition of sugars was advantageous. The milk was analyzed. The growth of the pigs in proteid substance was determined by analyzing a new-born pig of the same litter which was killed at birth. The percentage proteid composition was taken to represent that of the living pigs at the start of the feeding. Any gain of proteid noticed in the analysis of the pigs after the fourteen days of feeding could be attributed to growth.

Another pig of a different litter was fed for fourteen days on whole milk of unknown composition.

For the calorific value of this milk Rubner's¹ average value has been assumed, — 1 litre = 650 calories.

The composition of the diet of the other pigs was determined by analysis, as follows (see first table, page 198) :

The calculation of the energy in the milks described in the table was made according to Rubner's standard values² for milk, as follows :

Proteid	4.4 calories
Fat	9.2 calories
Milk-sugar	3.9 calories

¹ LEYDEN'S Handbuch, 1897, Bd. 1, p. 113.

² RUBNER: *Zeitschrift für Biologie*, 1901, xlv, p. 280; also RUBNER und HEUBNER: *Zeitschrift für Biologie*, 1898, xxxvi, p. 55.

from which is deducted 5.4 per cent lost through the fæces. Rubner has shown that these theoretical calculations very nearly cover the fuel value actually available physiologically.

	Skim.		Lactose.		Dextrose.	
	Gms.	Calories.	Gms.	Calories.	Gms.	Calories
Proteid	214.5	943.8	281.5	1238.6	302.1	1329.2
Fat	36.5	335.8	48.0	441.6	51.5	473.8
Milk-sugar	305.8	1192.6	581.7	2268.6	435.0	1696.5
Dextrose	189.6	699.6
Total	2472.2	3948.8	4199.1
Less 5.4 per cent lost through fæces	133.5	213.2	226.7
Calories available physi- ologically	2338.7	3735.6	3972.4

Dextrose was calculated: 1 gm. = 3692 cal.

There can be no significance in the above figures unless the skimmed cow's milk is normally absorbed. To show this the fæces were collected, and the intestinal contents of the pig, killed twelve hours after his last meal, were mixed with the fæces for analysis.

The results may thus be indicated :

	Skim. Grams.	Lactose. Grams.	Dextrose. Grams.
N in milk fed	33.68	44.19	47.42
N in fæces	1.88	1.47	1.96
N excreted in fæces in per cent	5.6	3.3	4.1
Fat in milk fed	36.52	48.00	55.51
Fat in fæces	3.47	3.00	3.50
Fat excreted in fæces in per cent	9.5	6.2	6.8

Camerer¹ in seven experiments on children of different ages finds that there is a faecal excretion of 5.8 per cent of the nitrogen in a milk diet, and 4.7 per cent of the fat. Rubner² finds an average of 7.1 per cent of the nitrogen in the ingesta and 5.3 per cent of the fat, in the faeces of the adult on a milk diet. These figures show that the milk absorption in the pigs was similar to that in children. No milk-sugar was ever found in the urine. That the physiological utilization of the calories of milk is almost the same under different conditions has been shown by Rubner³ in the following table :

Physiologically available calories of mother's milk	91.6 per cent
Physiologically available calories of cow's milk	90.7 per cent
Physiologically available calories of cow's milk with milk-sugar	92.2 per cent
Physiologically available calories of cow's milk when ingested by an adult	89.8 per cent

The figures for the faecal contents indicate a normal absorption, and consequently a normal utilization of the milk by the pigs.

All the pigs developed rapidly except the pig fed on skimmed milk, which seemed feeble throughout the experiment, and did not suckle vigorously as the others did. The following table briefly includes the fourteen days' life-history of the pigs.

	Whole milk.	Skim.	Lactose.	Dextrose.
Weight of pig when born	550	1000	1050	1152
Weight of pig when killed	1008	1246	1890	2000
Growth in grams	458	264	838	848
Growth in per cent	82.1	26.4	79.7	73.6
Milk fed in c.c.	3059	6826	8836	9481
Available calories fed	[1989?]	2339	3736	3972
Growth in grams per litre of milk	149	38	95	89
Growth in grams per 1000 calories fed	[230?]	114	222	213

¹ CAMERER: *Zeitschrift für Biologie*, 1881, xvii, p. 493.
² RUBNER: *Zeitschrift für Biologie*, 1879, xv, p. 115.
³ RUBNER: *Zeitschrift für Biologie*, 1899, xxxviii, p. 380.

The discussion of these results will be deferred until later, but it may be observed in passing that, except in the case of the badly nourished pig fed on skimmed milk, the growth seems proportional to the calorific value of the food.

Concerning the proteid growth, it was first determined that a newborn pig of the same litter weighing 1137 grams, contained of his live weight 1.78 per cent of N or 11.17 per cent of proteid. If this be the true value at the birth of the other pigs, we can estimate the nitrogen contained in them at birth and deduct this from the actual nitrogen found at the end of the experimental feeding.

From this the growth of proteid matter may be calculated.

	Skim. N in grams.	Lactose. N in grams.	Dextrose. N in grams.
When killed	25.60	35.46	43.90
When born (estimated)	17.80	18.72	20.51
Growth	7.80	16.74	23.39
Growth in per cent	44.00	89.00	114.00
N in food	33.68	44.19	47.42
N metabolized	25.88	27.45	24.03
Per cent of N of food used to form new tissue	23.00	38.00	48.00

From the above figures it is seen that the retention of proteid for tissue building amounted to 23, 38, and 48 per cent in the three different pigs.

The method employed by Sanford and Lusk in these older experiments seemed to be capable of further extension, and at Professor Lusk's suggestion, and with his assistance, a new research was undertaken.

THE NEW EXPERIMENTS.

Work has been done of late by Camerer, Rubner, Oppenheimer, and others, which has added much of high importance to the knowledge of the laws of nutrition in the growing child. In such experiments on children the diet must naturally be unexceptionable. It seemed that these experiments might properly be supplemented by investigating the nutritive value of skim-milk to the growing organ-

ism. So great is the popular prejudice against skim-milk, that it has been made a crime to sell it in New York.¹

For these feeding experiments, pigs were selected on account of their rapid growth, their vigorous metabolism, and the fact that they, like man, are omnivorous. Their great muscular activity is the one decided cause of difference between their metabolism and that of a helpless infant.

Six new-born pigs of the same litter were obtained. Three of them were at once submitted to analysis, and three were reared on skim-milk. Of these three, one, the skim-milk pig, was fed on skim-milk alone; another, the lactose pig, received the same skim-milk to which three per cent of lactose had been added; and a third pig, the dextrose pig, was nourished with the same skim-milk containing three per cent of added dextrose. After sixteen days the pigs were killed and submitted to analysis.

At first glance it may be said that the experiments are far too few in number to prove anything, and yet the general uniformity of the results obtained, and their accordance with the observations made on children, render this objection less valid.

About forty litres of skimmed cow's milk were obtained in winter, fresh from the Briarcliff Farm, which establishment also furnished the pigs. I desire to express my thanks to the company and its employees for their trouble in the matter. About one third of the milk was treated with 30 grams of lactose hydrate per litre, and another third with 30 grams of dextrose per litre. The milk was measured, 200 c.c. at one time (using Cremer's two-way stop-cock pipette), into ordinary nursing bottles, which were stoppered with cotton and frozen in the ice machine of the anatomical department. From time to time the bottles were thawed, as they were needed, and warmed for use. The milk remained perfectly sweet throughout the experiment. It agreed perfectly with the pigs, and there was no diarrhœa in any of them at any time.

The nitrogen of the milk was ascertained, by making Kjeldahl determinations: the fat, by weighing the ether extract of the milk dried on fat-free paper; and the milk-sugar, by the Allihn method, after precipitating the proteid. Calcium was determined after incineration of the total solids. The potential energy was calculated as before,

¹ Valuable information on the nutritive value of the skim-milk may be found in: *Milk as Food*, U. S. Dept. of Agriculture, 1898, *Farmers' Bulletin*, No. 74.

although a loss through the fæces of 5.4 per cent of the energy of the added sugars is hardly possible. Rubner has shown us, as before described, that there is a higher average utilization of the calorific power in milk after the addition of lactose.

1000 c.c. skim-milk.		
	Grams.	Calories.
Proteid	41.73	183.6
Fat	1.40	12.9
Lactose	50.2	195.8
CaO	1.99	
Total		392.3
Less 5.4 per cent		21.2
Calories physiologically available		371.1

The addition of 30 grams of lactose hydrate strengthened the milk with 27.9 grams of lactose per litre, containing 108.8 calories. Deducting 5.4 per cent from this (= 102.9), it is evident that the milk fed to the lactose pig had an energy equivalent of 474 calories per litre.

Thirty grams of dextrose added to the skim-milk raised its value by 110.8 calories (- 5.4 per cent = 104.8). The dextrose pig was, therefore, fed with a calorific equivalent of 475.9 calories per litre.

The relative calorific value of the three milks may be computed :

Dextrose milk	100.0
Lactose	99.6
Skim-milk	77.9

Of 100 calories in the food there were :

	Skim.	Lactose.	Dextrose.
Proteid	47.0	36.5	36.5
Fats	3.0	2.5	2.5
Carbohydrates	50.0	61.0	61.0

The value for proteid is here very high. Rubner,¹ calculating the gross calories of mother's milk on the fourteenth day of lactation, states that the proteid contains 16.7 per cent, the fat 47.2 per cent, and lactose 36.1 per cent of the calories.

Day.	Skim.		Lactose.		Dextrose.		Date. 1902.
	Milk. c.c.	Weight. Gms.	Milk. c.c.	Weight. Gms.	Milk. c.c.	Weight. Gms.	
1	1322	1295	1485.7	Jan. 18
2	244	1335	362	1358	320	1541.5	" 19
3	281	1824	388	1384	220	1524.5	" 20
4	460	1329	445	1380	368	1502	" 21
5	359	1381	600	1495	359	1610	" 22
6	605	1446	643	1601	503	1643	" 23
7	667	1490	549	1628	550	1699	" 24
8	696	1524	800	1742	640	1762	" 25
9	705	1605	697	1820	550	1791	" 26
10	675	1672	621	1875	636	1907	" 27
11	695	1733	682	1961	670	1997	" 28
12	785	1776	790	2050	768	2074	" 29
13	845	1839	590	2057	686	2090	" 30
14	825	1878	905	2114	785	2156	" 31
15	1028	2000	1000	2255	835	2249	Feb. 1
16	1032	2112	905	2348	970	2383	" 2
17	1020	2205	1028	2435	847	2471	" 3
....	10925	11005	9707	

The amount of proteid in sow's milk is normally high. König² gives 7.24 per cent as the mean in eight sows, while six days after parturition it is given as high as 12.89 per cent. The pig's organism

¹ RUBNER: Leyden's Handbuch, Bd. 1, p. 134.

² KÖNIG: Zusammensetzung der menschlichen Nahrungsmittel, 1889, p. 350.

may, therefore, be fitted for a high proteid coefficient. The mean for milk-sugar in the sow's milk is given as 3.13 per cent, and for fat as 4.55.

The three pigs which were fed on the three milks above described grew rapidly and normally. The dextrose pig, which was heaviest at the start, took his food with greater slowness than the others, sometimes suckling forty-five minutes in taking the volume of milk which the other two drank in fifteen minutes. There were nine feedings on each of the first two days, seven feedings from the third to the seventh day, and six feedings daily thereafter. The pigs were fed every three or four hours, including the night hours, as they would awake between three and four o'clock and cry for food. The pigs were all strong and active, and exercised freely about the room.

The amount of milk fed, and the growth of the pigs is shown in the table on page 203.

From this it is seen that in sixteen days the skim-milk pig drank 10.925 litres (= 4053.2 calories), the lactose pig drank 11.005 litres (= 5216.4 calories), and the dextrose pig drank 9.707 litres (= 4619.6 calories).

It is now possible to tabulate some of the facts regarding the growth of the pigs, and to compare these results with those of Sanford and Lusk.

	WILSON.			SANFORD and LUSK.		
	Skim.	Lac- tose.	Dex- trose.	Skim.	Lac- tose.	Dex- trose.
Weight when born	1322	1295	1485	1000	1050	1152
Weight when killed	2205	2435	2471	1246	1890	2000
Growth in grams	883	1140	986	264	838	848
Growth in per cent	66.8	88.0	66.4	26.4	79.7	73.6
Milk fed in c.c.	10925	11005	9707	6826	8836	9481
Available calories fed	4053	5216	4620	2339	3736	3972
Growth in grams per litre of milk . . .	81	114	101	38	95	89
Growth in grams per 1000 calories fed	218	215	213	114	222	213

It is seen from the above that the growth of the pigs in grams is directly proportional to the calorific value of the food to the organism.

The one exception was that of the ill-nourished skim-milk pig of Sanford and Lusk. Here is an individual improperly nourished, taking too little food, and remaining behind his fellows in normal development. But that five out of six pigs of different litters, different sizes, and differently fed should gain in weight, respectively, 213, 213, 215, 218, and 222 grams per thousand calories fed, seems more than a coincidence. Oppenheimer¹ has shown that the growth in grams of normal breast-fed children of the same age may be nearly proportional to the litres of milk fed. Here the milk presumably has the same calorific value, although this could not be determined. Oppenheimer's table is here reproduced:

Growth in grams for 1 kg. Milk.		
Month.	FEER.	OPPENHEIMER.
I	33.8	95.0
II	191.2	201.1
III	120.3	138.5
IV	102.6	103.3
V	75.7	120.8

In the second, third, and fourth months of these children's lives the growth is uniformly proportional to the milk, or energy, fed.

It seems, therefore, probable that the growth of sucklings in good health, and fed with proper and abundant food, stands in a definite relationship to the amount of energy in the food.

Having determined this ratio of growth, it seemed desirable to estimate the constituents of the new tissue, and if possible to calculate the energy equivalent added to the body in the course of this growth.

For this purpose the pigs were analyzed. Three of the new-born pigs were first analyzed. The results were so similar in all three, that it is justifiable to assume that the three bottle-fed pigs of the same litter started with the same percentage composition. Any increase above this estimated original composition may be ascribed to growth under the influence of diet. The proteid content was estimated by multiplying the amount of N found by 6.25, without regard to the extractives.

¹ OPPENHEIMER: *Zeitschrift für Biologie*, 1901, xliv. p. 147.

In preparing the pigs for analysis, each animal was dissected, and the intestinal canal cleaned of its contents. The different portions of the pig were put in dishes, covered with 95 per cent alcohol, left for twenty-four hours, and evaporated over a steam bath. This process was repeated two or three times. All the organs could then be put through a sausage machine, except the bones. The parts were dried in a drying oven at 97°, ground in a mortar or put through a coffee-mill, and finally passed through a sieve. The skin with the hair, the bones, and all the other parts were thus reduced to a homogeneous mixture yielding equal values in duplicate analysis. Nitrogen was determined by the Kjeldahl method, moisture by drying to constant weight, fat by prolonged ether extraction, which, according to E. Voit,¹ will yield 95-97 per cent of the fat present. CaO was determined after incineration.

The results were as follows :

	Live weight.	Solids.	Fat.	Fat. Per cent.	Proteid.	Proteid. Per cent.	CaO.	CaO. Per cent.
Pig I	1044	205.1	13.70	6.68	127.3	62.6	19.28	9.40
" II	1142	226.4	17.65	7.79	136.1	60.1		
" III	1016	207.9	16.21	7.79	127.1	61.1	19.52	9.39
" skim	2205	436.2	28.34	6.56	321.3	73.6	36.17	8.29
" lactose	2435	495.7	34.88	7.04	360.0	72.6	39.77	8.02
" dextrose	2471	495.2	33.21	6.71	349.1	68.5	10.27	8.13

The aggregate live weight of the new-born pigs I, II, and III was 3,247 grams, and their percentage composition may be thus computed :

	Grams.	Per cent.
Live weight	3,247	
Dry solids	637.4	= 19.7
Fat	47.56	= 1.15
Proteid	390.5	= 12.0
CaO (average of two pigs)		= 1.88

With these figures it is possible to obtain the data regarding the growth of the three pigs which were fed.

¹ Voit, E.: *Zeitschrift für Biologie*, 1897, lv, p. 55.

Pig.	Estimated composition at start.				Composition as determined at end.				Growth.			
	Solids.	Fat.	Pro-teid.	CaO.	Solids.	Fat.	Pro-teid.	CaO.	Solids.	Fat.	Pro-teid.	CaO.
Skim	260.4	15.20	158.90	24.85	436.2	28.34	321.3	36.17	175.8	13.18	162.4	11.32
Lactose	255.1	14.89	155.66	24.35	495.7	34.88	360.0	39.77	240.5	20.01	204.3	15.42
Dextrose	292.5	17.08	178.50	27.92	495.2	33.24	349.1	40.27	202.7	16.16	170.6	12.35

It is clear that the milk-sugar pig made the most progress, the dextrose pig next, and the skim-milk pig the least.

It will now be interesting to note to what extent the diet affected the growth. Recalling the composition and amount of the milk ingested it is possible to estimate the percentage of the food constituents absorbed and used for growth :

Pig.	Food fed.			Growth.			Per cent used for growth.		
	Proteid.	Fat.	CaO.	Proteid.	Fat.	CaO.	Proteid.	Fat.	CaO.
Skim	455.6	15.29	21.74	162.4	13.18	11.32	35.6	86.00	52.00
Lactose	458.9	15.40	21.90	204.3	20.01	15.42	44.5	130.00	70.00
Dextrose	404.8	13.59	19.32	170.6	16.16	12.35	42.1	111.00	64.00

Proteid, it is apparent, was well utilized for growth. The skim-milk pig used 35.6 per cent of the proteid fed for growth, the lactose pig 44.5 per cent, while the dextrose pig used 42.1 per cent. The sugars naturally promoted the saving of proteid for the organism. This proportion of proteid retained for growth accords with the 40 per cent given by W. Camerer, Jr.,¹ for a nine-weeks old nursing baby, and with the values already cited in Sanford and Lusk's experiments, *i. e.*, 23 per cent for the skim-milk, 38 per cent for the lactose, and 48 per cent for the dextrose pig.

The increase in fat in the pigs was surprising in view of the poverty of the milk in this material. The newly-born pigs were all very poor

¹ CAMERER: *Zeitschrift für Biologie*, 1902, xliii, p. 1.

in fat at the start, and they seem to have absorbed and deposited most of the fat ingested. The skim-milk pig deposited the least fat, while those fed with the added sugars apparently increased in fat more than would have been possible if this increase had been derived from the amount of fat in the food. Two explanations are here possible, either the fat in the milk was slightly underestimated (a small factor would make considerable difference) or milk-sugar was converted into fat. The latter would have been possible through the intestinal inversion into dextrose and galactose, and subsequent conversion of a part of the galactose into glycogen. In this way perhaps 75 per cent of dextrose arises from milk-sugar, which dextrose might be partly converted into fat. The principal point which is indicated by this almost complete assimilation of the fat fed to the pigs, is that the carbohydrates fed were amply sufficient to furnish the needed energy, while a normal growth of tissue was progressing. No fat combustion was necessary for the life-processes.

Of the calcium in the food, the skim-milk pig used 52 per cent for growth, the lactose pig 70 per cent, and the dextrose pig 64 per cent. It would seem from this that diet had an influence on the absorption, but a more correct idea is given when it is remembered that the dry solids of the three pigs contained 8.29, 8.02, and 8.13 per cent of calcium respectively. It seems, therefore, that the calcium addition depended rather upon the development of the organism than upon any specific influence of the milk constituents. It has been said that absorption of the calcium of skim-milk is imperfect, and that children are inclined to become rickety when so fed. Herter¹ has found striking retardation in the development of the skeleton in older pigs after feeding them on skimmed milk for many months. He, however, notes no signs of rickets. It might be due to the general malnutrition induced by a monotonous or iron-poor diet like skim-milk. Certainly my experiments show no untoward influences. W. Camerer, Jr.,² finds that the amount of calcium in mother's milk is barely sufficient to cover the needs of the nursing infant, if the percentage composition of the five-months old baby is the same as that of the new-born baby. The explanation of this may be derived from my experiment, which shows that the percentage of calcium content of the solids in the new-born pig averages 9.40 per cent, in contrast with 8.15 per cent at an age of two weeks and a half. If at the end of sixteen-days nursing

¹ HERTER: *Journal of experimental medicine*, 1898, iii, p. 203.

² CAMERER: *Zeitschrift für Biologie*, 1902, xliii, p. 1.

the lactose and dextrose pigs had contained 9.40 per cent CaO, an almost complete absorption of CaO would have been necessary.

The study of the growth of the suckling animal would not be complete without an attempt to calculate the energy liberated in the animal. We may calculate the number of calories in the food, and we may calculate the number of calories contained in the proteid and fat added to the body in the process of growth. Rubner¹ has shown that the heat value of decomposing proteid tissue in starvation is not far different from the heat value of meat. Of course proteid metabolism in starvation is at the expense of all the organs. Rubner shows a heat value of 24.98 calories for 1 gram of nitrogen from proteid metabolism in starvation. This value has been adopted in the calculations. It has not been possible to enter into the individual heat equivalents of the hair, skin, hoofs, etc. The heat value of the fat has been taken as 9.3.

The growth of the pigs in potential energy is as follows:

	N. Grams.	Fat. Grams.	Calories in proteid.	Calories in fat.	Total.
Skim	25.98	13.18	649	123	772
Lactose	32.68	20.01	816	186	1002
Dextrose	27.30	16.16	682	150	832

Of the energy added to the skim-milk pig, 16 per cent was in fat; to the lactose pig, 18.6 per cent, and to the dextrose pig, 18 per cent was in fat. These data now permit the calculation of the following table:

	Skim. Calories.	Lactose. Calories.	Dextrose. Calories.
In the food	4053	5216	4620
Stored in the body	772	1002	832
Liberated as heat	3281	4214	3788
Fed daily per square metre of surface	2008	2404	2087
Liberated as heat daily per square metre of surface	1618	2005	1600
Retained per 1000 calories in the food	191	192	180

¹ RUBNER: Zeitschrift für Biologie, 1894, xxx, p. 94.

The calculations of the surface were made from the formula of Meh in which the value of k was taken to be 9.02 as suggested by E. Voit.¹ For g in the formula the average weight during the whole experiment was taken.

The energy requirements of these pigs were much higher per square metre of surface than those of the human infant or of the adult pig.² The human infant requires daily in the food about 1200 calories per square metre of surface, while a more active older child requires 1500. The 2400 found for the lactose pig corresponds to that needed by a man at hard labor. The results as obtained with the pigs are to be explained only with the premises that the very active pigs nursing every three hours represented to a large degree a life of hard work. The bottle was usually taken with great vigor, and the pigs did much scrambling among themselves.

The most striking result, however, is in the proportion of calories retained in the pig for growth. It has been said that the pigs gained in weight in proportion to the calories in the food: not only is this true, but the calories retained in the pigs were proportional to the calories in the food. The following table indicates the comparison:

	Skim.	Lactose.	Dextrose.
Gain of pig in grams per 1000 calories in the food	218	215	213
Gain of pig in calories retained per 1000 calories in the food	191	192	180

The storage of 18 to 19 per cent of the energy in the food in the formation of new tissue finds a counterpart in a respiration experiment cited by W. Camerer, Jr.,³ where 15 per cent of the energy in the food of a nursing baby nine weeks old was retained in the body, and in a similar experiment of Rubner and Heubner⁴ on a baby seven and a half months old, where 12.2 per cent were so retained.

The results accord with Oppenheimer's calculations before mentioned, which showed that the gain in weight of growing babies of the same age was proportional to the milk ingested.

¹ E. VOIT: *Zeitschrift für Biologie*, 1901, xli, p. 113.

² E. VOIT: *Loc. cit.*

³ CAMERER: *Loc. cit.*, p. 10.

⁴ RUBNER und HEUBNER: *Zeitschrift für Biologie*, 1899, xxxviii, p. 345.

But the results show further that a large and apparently normal growth takes place when skimmed milk, containing a plentiful supply of proteid, is fed, and that this growth is favorably influenced by the addition of sugars, which improve the nutritive value in that they add further calorific power to the milk.

Bunge¹ states that a suckling pig doubles in weight in eighteen days. The skim-milk pigs gained as much as 80 per cent in weight in from fourteen to sixteen days, an apparently normal growth.

The results of this research lead me to believe with Camerer that, provided the milk contains sufficient proteid, the suckling can increase in size and strength, whether the necessary additional fuel-value is furnished by fat, milk-sugar, or dextrose.

The presence of fat in the milk greatly reduces the bulk necessary to supply the needed calories, and too much water is to be avoided;² but when milk-fat disagrees with an infant, there seems to be reason to believe that skim-milk with milk-sugar can be fed without prejudicial effect.

It is to be regretted that a comparison with pigs reared upon whole milk is impossible. The great labor involved does not at present permit the attempt of the series of experiments necessary for such a comparison.

SUMMARY.

1. Skimmed cow's milk, with or without 2 to 3 per cent of added lactose or dextrose, is normally absorbed by suckling pigs.

2. Two pigs fed on skim-milk from fourteen to sixteen days gained 26.4 and 66.8 per cent in weight. Two pigs fed on the same skim-milk, with 2 and 3 per cent of lactose added, gained 79.7 and 88.0 per cent in weight. Two pigs fed on the same skim-milk, with 2 and 3 per cent dextrose added, gained 73.6 and 64.4 per cent in weight.

Those fed with plain skim-milk gained 114 and 218 grams in weight for every 1000 physiologically available calories in the food. The lactose pigs gained 222 and 215 grams per 1000 calories in the food. The dextrose pigs both gained 213 grams per 1000 calories in the food. Except in the case of one ill-nourished skim-milk pig, the growths of the sucklings stand in a constant ratio to the calories in the food.

¹ Cited by ADERHALDEN: *Zeitschrift für physiologie Chemie*, 1899, xxvi, p. 497.

² RUBNER und HEUBNER: *Zeitschrift für Biologie*, 1899, xxxviii, p. 397.

4. The pigs fed on plain skim-milk used 23 and 35 per cent of the proteid in the food for tissue growth, the lactose pigs used 38 and 44 per cent, and the dextrose pigs 48 and 42 per cent.

5. All the pigs of the second litter gained in fat when fed on plain skim-milk or on skim-milk with sugars.

6. The percentage of calcium in the bodies of the pigs diminished with their growth. There was considerable and normal deposition of calcium in the pig, and this was proportional, not to the calcium in the food, but to the growth of the animal.

7. Not only is the growth in grams of the pigs proportional to the calories in the food, but the number of calories retained in the tissue substance during growth is proportional to the calories in the food. 18 to 19 per cent of the calories in the food were found stored in the tissue growth of the pigs fed on the three varieties of skimmed milk.

8. There seems to be striking evidence that the suckling pig reared on skimmed cow's milk conforms to the same laws of nutrition as the breast-fed infant.

MAXIMAL CONTRACTION, "STAIRCASE" CONTRACTION, REFRACTORY PERIOD, AND COMPENSATORY PAUSE, OF THE HEART.

By R. S. WOODWORTH.

[From the Laboratories of Physiology in the Harvard Medical School and in the University and Bellevue Hospital Medical College.]¹

I. EXPERIMENTS ON THE APEX OF THE DOG'S HEART.

THE mammalian apex preparation, introduced by Porter,² has not as yet been used for testing the response of cardiac muscle to electrical excitation. It is, however, very suitable for this purpose, first because, if supplied through a nutrient artery with warmed, oxygenated, defibrinated blood, it beats spontaneously, and secondly because it is devoid of ganglion cells, and thus is a true muscle preparation.

It was found desirable in many of the experiments to record the moment of stimulation on the muscle curve itself by means of the spark chronograph.³ A strong battery current was passed through an interrupter (adjusted commonly to $\frac{1}{10}$ sec.), an electromagnet designed to serve as a time-marker, and the primary coil of an inductorium. One pole of the secondary coil was connected to the recording drum, and the other pole to the apex preparation, thence through a fine copper wire to the writing lever (the wire also served to suspend the lever from the apex preparation), and by a continua-

¹ These experiments were begun in 1897-8 under the direction of Dr. W. T. PORTER. Left incomplete then, and interrupted by other work until recently, they were resumed in 1901-2. The results of this second series, performed after so long an interval and in a different laboratory, as well as with slightly changed apparatus, agree perfectly with the earlier results and may almost be regarded as an independent confirmation of them.

² PORTER: Journal of experimental medicine, 1897, ii, p. 391; also: This journal, 1898, i, p. 514. The essential parts of this apparatus are shown in Fig. 1 of Dr. CLEGHORN'S paper, This journal, 1899, ii, p. 275.

³ For a convenient reference to the spark chronograph, see SCHÄFER'S Text-book of Physiology, 1900, ii, p. 750. The arrangement of the electric circuits in my apparatus differed considerably from that described by SCHÄFER.

tion of this wire inside the lever to the writing point of copper foil. A strong spark, by jumping from the writing point through the paper to the drum, knocked off a little lampblack and left a round spot on the muscle tracing at the instant of stimulation. A key was placed in the secondary circuit. To moderate the current sent through the heart, a shunt was sometimes used.

MAXIMAL CONTRACTION.

The peculiar properties of cardiac muscle, discovered by Bowditch on stimulation of the apex of the frog's ventricle,¹ hold in full force for the perfused apex of the dog's heart. Chief among these properties is the law of maximal contraction, or of "all or none."² Any contraction, however weak be the stimulus that arouses it, has the maximal force that the muscle can exert at that moment. Increasing the stimulus above its minimal effective strength does not increase the force of the response. The minimal stimulus is also maximal.

I have demonstrated this property as follows. A series of contractions was first produced by minimal stimuli. When the height of contractions was well established, the intensity of the stimuli was suddenly greatly increased. After some time, the intensity was reduced to its former point. But no changes in the height of contraction were produced by these changes in the stimulus.

STAIRCASE CONTRACTION.

A second property of cardiac muscle, discovered by Bowditch³ in the frog, and holding also in the dog, is "staircase" contraction. If a quiescent apex is excited by a series of stimuli, the first response is usually feeble, and the later ones increase gradually to a maximum, at which level they remain. If, however, the rate of stimulation is then hastened, a new staircase results. Or, if the rate is slackened, the result is a descending staircase (Fig. 1).

The chief point of difference between staircase contraction in amphibian and in mammalian cardiac muscle is the length of the *optimum interval*. Bowditch⁴ found that the strongest series of contractions was elicited from the frog's apex by stimuli having an

¹ BOWDITCH: *Arbeiten aus der physiologischen Anstalt zu Leipzig*, 1871, p. 139.

² Confirmed by McWILLIAM on the mammalian heart. *Journal of physiology*, 1888, ix, p. 168.

³ BOWDITCH: *Op. cit.*, p. 156.

⁴ BOWDITCH: *Op. cit.*, p. 160.

interval of four or five seconds. In the dog's apex, the optimum interval is about one second, usually somewhat less.

The length of the optimum interval is governed by the interplay of two opposing factors, as will be clear from a study of Fig. 2. No long series of rapid beats is necessary to produce an increase in height.

A single contraction following another at a short interval is sufficient to increase the height of the following contractions. The shorter also the interval between two contractions, the greater is their strengthening effect on the following contractions.

The shortest interval in Fig. 2 is about half a second. It will be seen, however, that a contraction following very quickly after another is itself very small, and that at the beginning of the long series of rapid stimuli, the first two contractions are weaker and

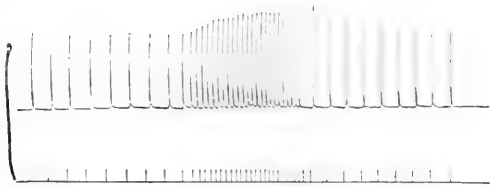

FIGURE 1.—Dog's apex. Electrically excited contractions. "Staircase" resulting from increase in rate of stimulation, and descending staircase resulting from decrease in rate. The interval between the slow stimuli is about $3\frac{1}{2}''$, and that between the rapid stimuli about $1''$.

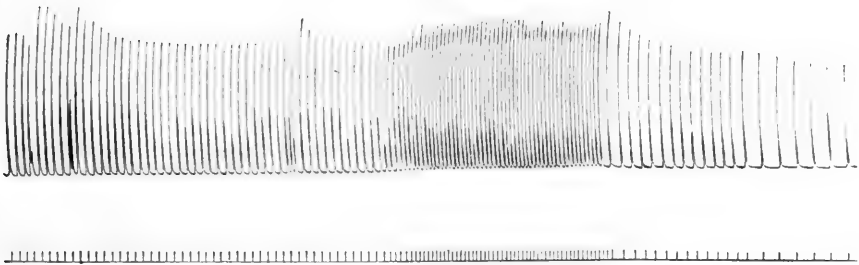

FIGURE 2.—See legend of Fig. 1. Note in addition three extra contractions, probably spontaneous, and the increased height of the contraction which follows each.

not stronger than those that precede, whereas at the end of the rapid series, the first two slow contractions are stronger than the contractions that precede.

The two opposing factors are then *the stimulating effect of a rapid succession of contractions, and the recuperative effect of a long pause.* On the one hand, the following of one contraction close upon another acts to accelerate the production of available energy immediately afterward; but on the other hand, the production of available energy is



FIGURE 3.—Dog's apex. One spontaneous contraction at the start and two at the close. Between, the result of trying to tetanize the muscle by a series of strong induction shocks, 18 per second. The shocks are indicated by dots, which were produced by sparks passing through the paper between the drum and the writing point.

a gradual process, and a long pause enables more to accumulate than does a short pause. A short interval preceding a contraction tends to make that contraction weak and the following contractions strong.

The strongest possible contraction is secured, therefore, by producing, first, two or more contractions in rapid succession, so as to accelerate the production of energy, and allowing after that a considerable interval for its accumulation. And the smallest contraction may be secured by first depressing the contractility by a slow series of contractions, and then following the last of these by another contraction at the briefest possible interval. Bearing in mind the two opposing factors, it has been possible for me to produce strong or weak contractions at will, and to predict with considerable certainty the height of each spontaneous contraction. The ability to control and predict is good evidence of the reality of the factors in question.

Further evidence is seen in the tracings obtained on attempting to tetanize the heart muscle. Fig. 3 shows the stimulating effect of a rapid series of contractions, and it also shows that the full benefit of such stimulation is only got by means of a considerable pause.

Incidentally, one may note in this tracing the fact that the mammalian apex, like the frog's heart,¹ does not respond to faradization by a true tetanus. It responds either by fibrillary contraction or by a rapid series of beats. Walther² has found in the frog's ventricle something closely resembling the

¹ KRONECKER and STIRLING: Beiträge zur Anatomie und Physiologie als Festgabe zu Ludwig, 1874, p. 173.

² WALTHER: Archiv für die gesammte Physiologie, 1900, lxxviii, p. 605, p. 624.

incomplete tetanus of striped muscle, with superposition, in case the heart, having rested for some time, was capable of staircase contraction. Walther holds that wherever staircase contraction would be produced by a series of single shocks, an incomplete tetanus would result from faradization. Now since the dog's apex is capable of staircase contraction at almost any time, even when beating spontaneously, an incomplete tetanus should accordingly be always aroused by faradization. I have never secured this result. I have obtained very rapid series of beats showing staircase contraction, but nothing comparable to the superposition of one contraction on another, such as appears in true tetanus.

In Fig. 3 is seen also an alternation of stronger and weaker contractions. Essentially the same phenomenon has been noted by Langendorff¹ and by Hofmann² in the frog's heart, and by Cushny and Matthews³ in the intact dog's heart. It is more pronounced in the dog's apex than in the frog's heart, and is usually harder to avoid than to secure.

The question arises, whether this alternation can be explained by the two factors already mentioned, namely, the stimulating effect of a rapid succession of contractions, and the recuperative effect of a long pause.

The explanation already offered by Cushny and Matthews and by Hofmann takes account of one of these factors, namely, the recuperative effect of the pause. Since a very strong contraction is also much prolonged, the pause following it is shortened; consequently, the succeeding contraction is weak. The weak contraction, being also of short duration, is followed by a long pause which strengthens the next contraction.

Reference to Fig. 3 will show this explanation to be possible. But explanation is equally possible in terms of the other factor. The contraction following a prolonged contraction is practically hastened, and so doubtless exerts a stimulating after-effect, etc. It is probable that the two factors co-operate to produce the alternation, but, in the dog's apex, the effect of hastening a contraction is stronger than the effect of prolonging a pause.⁴

¹ LANGENDORFF: *Archiv für Physiologie*, 1885, p. 287.

² HOFMANN: *Archiv für die gesammte Physiologie*, 1901, lxxiv, p. 145 ff.

³ CUSHNY and MATTHEWS, *Journal of physiology*, 1897, xxi, p. 222.

⁴ Fig. 3 is also of some interest as showing that the curves of returning irritability and contractility after a contraction may differ considerably. The irritability

No notice has thus far been taken of two possible objections to the explanation offered for staircase contraction.

First, the question may be raised whether the stimulating effect of a rapid series of contractions is not rather to be traced directly to the electricity used to elicit the contractions. The answer to this is that the same stimulation appears, without electricity, when, from any internal cause, the spontaneous rhythm of the apex is quickened; also, that no electrical stimulation, applied during the refractory period of successive spontaneous contractions, avails to produce staircase contraction.

Secondly, it may be questioned whether the stimulating influence of small interpolated contractions, such as appear in Figs. 2 and 3, may not be due merely to their smallness, rather than to the quickness with which they follow the preceding contractions. Does not, in short, a weak contraction tend to make the next one strong, and a strong

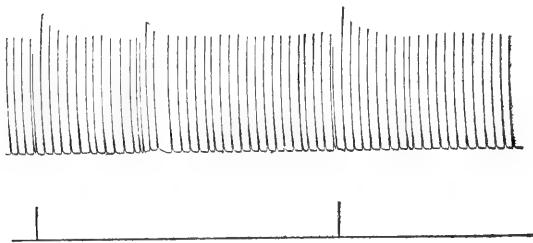

FIGURE 4.—Dog's apex. Spontaneous contractions, at intervals of about $3\frac{1}{2}\%$. Several hastened spontaneous contractions, also two contractions excited by electric shocks.

contraction to make the next one weak, and is not this the cause of the alternation? The difficulty with this explanation is that it breaks down in the case of staircase contraction. There, each contraction is strong by comparison with the one before, yet shows no tendency to weaken the next contraction.

Further, the tracing in Fig. 4 gives direct evidence for the view here adopted, and against the two objections just raised. This tracing shows that a spontaneous hastened contraction strengthens the following contractions, in the same way as a contraction hastened by electrical stimulus. It also shows that a contraction need not be weak in order to strengthen the next contraction; it need only be hastened. It is indeed impossible much to hasten a contraction without making it weak, but if the hastening is slight the weakening is not perceptible, and yet the following contraction is perceptibly strengthened.

must be practically equal at the beginning of each contraction, since the stimulus is nearly constant, but the contractility is far from being always equal.

THE REFRACTORY PERIOD.

During the systole or contraction-phase of the apex, *i. e.* during the period corresponding to the ascending limb of the cardiomyogram, the muscle is refractory to stimuli. This condition persists through-

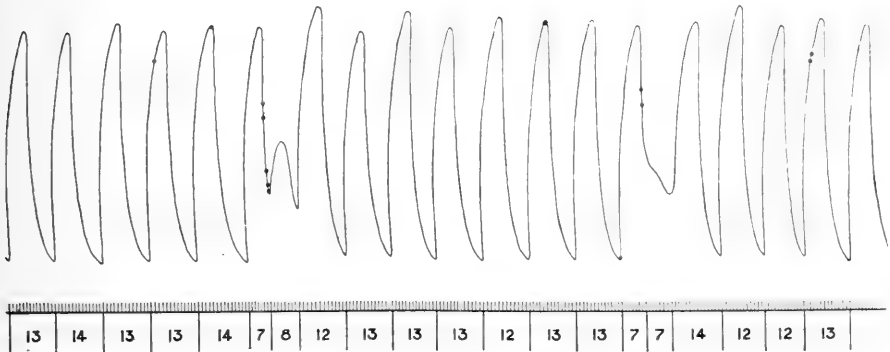

FIGURE 5.—Dog's apex. Spontaneous contractions. Also stimulation during contraction and during relaxation. Points of stimulation indicated by round spots along the course of the muscle tracing. Time in $\frac{1}{8}$ "', and numbers are in terms of this as unit.

out the whole of the systole. Stimulation during this phase neither alters the force and duration of the contraction then in progress, nor arouses an extra contraction after it. See Fig. 5. As this is an

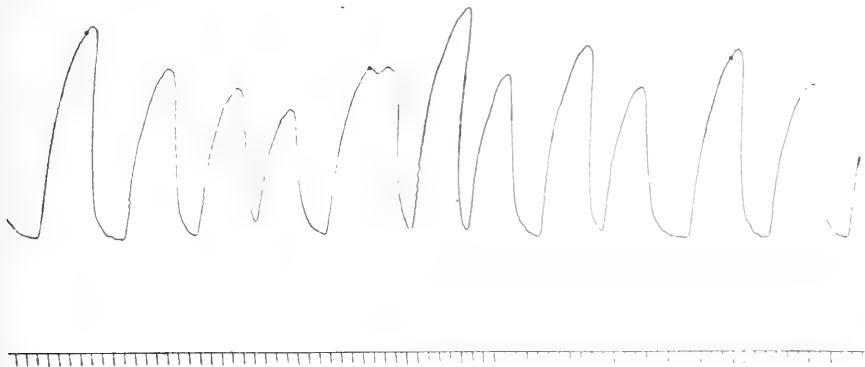

FIGURE 6.—Dog's apex. Spontaneous contractions. Exact limit of the refractory period. Point of stimulation indicated by dot on the muscle tracing. Time in $\frac{1}{16}$ "'.

admitted property of cardiac muscle, its appearance in the apex calls for no discussion. A few details should be recorded:

- I. The refractoriness is absolute. I have used induction shocks

strong enough to throw a two-millimetre spark, and also direct battery currents of six volts, without eliciting any response.

2. Weak contractions as well as strong, and electrically excited as well as spontaneous contractions, show the same refractory period.

3. The end of the refractory period, as is illustrated by Fig. 6, is at the very summit of the myogram. The beginning of descent marks the beginning of the irritable period.

4. The irritability is not restored all at once at the beginning of diastole, but by degrees. Very strong shocks are necessary to elicit an "extra" contraction early in diastole, but comparatively weak shocks suffice when relaxation is almost complete.

THE COMPENSATORY PAUSE.

When an intact heart, including ventricle, auricle, great veins and sinus, is beating normally, and an extra contraction is aroused by electrical or mechanical stimulus applied to the auricle or ventricle, a long pause follows the extra contraction.¹ On measuring the length of this pause, it is found to compensate very exactly for the shortness of the interval preceding the extra contraction. The earlier the extra contraction has come, the longer is the pause. The time measured from the beginning of the last regular systole before the extra contraction to the beginning of the first subsequent regular systole is equal to two regular beat periods. The ventricle misses one regular beat, and waits till the regular time of the next beat. Thus the rhythm of the heart is only momentarily disturbed by the artificial stimulus, and the following beats come at the same instants as if no extra contraction had occurred.

The question comes, whether the spontaneously beating mammalian apex shows this familiar action of the intact heart. It may be stated definitely that it shows nothing of the kind. An examination of Fig. 5 sets the matter at rest. Fig. 4 is equally conclusive. Fig. 6 is less suitable for purposes of demonstration, since the rate of the spontaneous beat is uneven, yet it shows clearly that the extra contraction is not followed by a prolonged pause. Not only is there no exact compensation, but there is not the slightest tendency to prolong the pause. On the whole, the pause following the extra contraction is shorter than the regular pause.

¹ MAREY: *Travaux du laboratoire*, 1876, p. 73.

These statements will be fortified by a closer examination of Fig. 5. The regular periods before the first extra contraction measure 13 and 14 units of time. A double period is then 27 units. If there were a compensatory pause, 27 units would measure the time from the last regular systole before the extra contraction to the first after it. The actual measure of this time is 15 units. In order to compensate, the time from the beginning of the extra contraction to the next regular beat should measure $27-7=20$ units, whereas it actually measures 8 units, considerably less than the regular single period.

The tracings presented are by no means exceptional. In an examination of several hundred cases, I have found only sporadic instances in which the pause following the extra contraction was even approximately compensatory. In a few cases, it is too long to compensate; but in the great majority it is too short.

In order to allow due weight to the exceptional cases in which the pause following the extra contraction was prolonged, I have measured somewhat over a hundred cases, including among them the longest pauses I could find, and taken the *average* of them. I find the average duration of the double period, measured from the beginning of the last systole before the extra contraction to the beginning of the first systole after it, to be 78.2 per cent of the regular double period.

Lest any reader should still be inclined to ascribe some special significance to the few cases in which the pause was approximately compensatory, I add, in Fig. 7, the "distribution curve" of the lengths of the double periods that included the extra contraction. Each is expressed as a fraction per cent of the regular double period preceding. Each dot in the figure represents one case, and it is seen that the cases are most frequent in the neighborhood of 60 and 70 per cent (56-75 per cent) of the regular double period. The cases are distributed in a shape similar to the "probability curve," though the present curve is somewhat "skew." The few cases near 100 per cent (*i. e.* nearly compensatory) fall easily into the general distribution curve, and there is no sign that they form a class by themselves or possess any special significance.

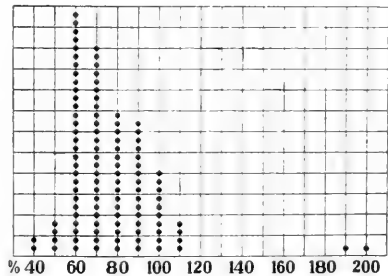

FIGURE 7. — Distribution curve of the lengths of the double period including the extra contraction, expressed in per cent of the regular double period. Each dot represents one case.

The double period including an extra contraction of the spontaneously beating apex is thus a variable quantity, which occasionally assumes values near to the regular double period but usually values much less. It differs in two respects from the corresponding period in cases where there is a true compensatory pause: it is, on the average, shorter, and it is much more variable.

The *single period*, measured from the commencement of the extra contraction to the next regular systole, averages 94.1 per cent of the regular single period (or 88.5 per cent, if we leave out the two very long pauses seen in Fig. 7, which are undoubtedly abnormal, since they come from pieces of apex that had not much spontaneity). In other words, the usual effect of the extra contraction is to hasten the rhythm of the apex, at least for one following beat.

In the intact heart, it will be remembered, the earlier the extra contraction comes, the longer is the compensatory pause. The reverse is true of the spontaneously beating apex: the earlier the extra contraction comes, the shorter is the following pause. This is at least the average tendency. It was detected as follows: The time from the beginning of the last systole before the extra contraction to the beginning of the extra contraction (which time I call "interval before extra") was measured, likewise the time from the beginning of the extra contraction to the beginning of the following spontaneous systole ("interval after extra"). Each of these intervals being then expressed as a per cent of the regular single period just preceding, the following relations appear:

Interval before extra.	Interval after extra.
40-70%	80.9%, average.
70-90%	102.9%, average.

As it seemed possible that the apex might show a delayed compensation for the hastening of the extra contraction, I measured also the double period beginning with the first systole after the extra contraction. I found, however, no compensation. When the double period including the extra contraction was short, the following double period was also usually short; but in the few cases in which the double period including the extra contraction was prolonged, the following double period also was prolonged. In other words, the effect of the extra contraction on the rhythm of the apex was somewhat persistent, usually hastening but occasionally slackening it.

The ventricular muscle has then no power to mark time, or to regain its regular times of contraction after they have been disturbed. It shows no tendency to compensate for the haste of one beat by delaying the next one; it shows the contrary tendency.

Since compensation is not a function of the spontaneously beating muscle, the suggestion readily occurs that it may be a function of the ventricular ganglia. But the presence of ganglion cells in the piece of muscle does not change the result, as is shown by the following experiment:

In place of the apex preparation, a piece of the *base* of the ventricle was used. When a fresh base preparation was perfused, the results obtained upon electrical stimulation were identical with those obtained from the apex. No compensatory pause appeared; the actual pause after the extra contraction was variable, usually somewhat less than the regular pause between beats.

The compensatory pause is, therefore, not a property of a spontaneously beating portion of the dog's ventricle, whether provided with ganglia or not.

The relation of this to other facts about the compensatory pause, and to the explanation of that phenomenon, will be deferred to a later page.

STIMULATING EFFECT OF THE EXTRA CONTRACTION.

The spontaneous beat following an extra contraction is, almost without exception, stronger than the preceding spontaneous beats.

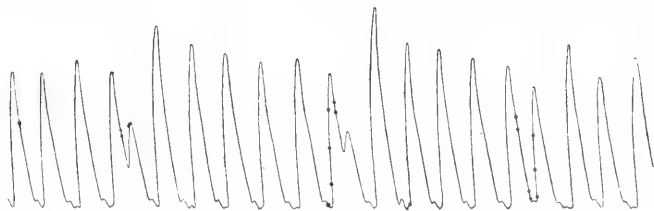

FIGURE 8.—Dog's apex. Spontaneous and extra contractions.

This fact has already been presented in some of the figures. It appears also in Figs. 8 and 9. Fig. 8 shows further that the earlier an extra contraction comes, the stronger is the following contraction; and Fig. 9 shows that two extra contractions are apt to be followed by exceptionally strengthened beats.

These statements, again, are based not simply on a few selected tracings, but on the average of all cases, so far as measured.¹ The statistical results are as follows:

1. The height of the contraction following the extra contraction averages 124.4 per cent of the height of the regular contraction preceding. In some preparations, especially where the regular beat is

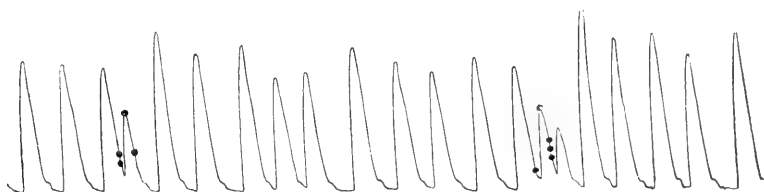

FIGURE 9.—Dog's apex. Spontaneous, and single and double extra contractions.

somewhat slow and weak, this average rises to 150 per cent; in some where the regular beat is very strong, it sinks to 110 per cent.

2. To compare the effect of two extra contractions with that of one, a special test was made on one apex. The beat following a single extra contraction averaged 113.7 per cent of the regular beat; while the beat following a double extra contraction averaged 125.7 per cent.² Three or more extra contractions were found to exert a stronger stimulant effect than two.

3. The statistical evidence that the beat following the extra contraction is the more strengthened, the earlier the extra contraction comes, is presented in the following table. The interval before the extra contraction is expressed as a fraction per cent of the regular period preceding it, and the height of the following contraction as a per cent of the height of the preceding regular beat.³

Interval before extra.	Av. height of following beat.
—39%	156.4%
40-59%	129.3%
60-79%	113.6%
80-114%	112.3%

¹ These cases were selected solely with reference to the accuracy with which they could be measured, and with reference to the uniformity of the spontaneous beats.

² The "probable error" of each of these determinations is about 1.4.

³ For greater certainty, the averages of the two preceding periods and heights were taken as the standards.

The shorter the interval before the extra contraction, the stronger is the following beat. The converse of this proposition is also true, as is seen on grouping the cases according to the height of the following beat, and finding for each group the average of the interval before the extra contraction. Thus :

Height of following beat. Per cent.	Number of cases.	Interval before extra. Per cent.	Interval after extra. Per cent.
—99	5	68.5	69.8
100-119	68	67.3	92.0
120-139	31	52.6	88.8
140-159	13	47.2	120.5
160-179	6	45.8	99.3
180-199	5	40.4	89.4
200-	3	40.0	129.3

On comparing the first and third columns, it is seen that where the beat following the extra contraction is strong, there the extra contraction has come early. This statement, together with its converse obtained from the previous table, establishes a dependence between the earliness of the extra contraction and the force of the following beat.¹

On comparing the first and last columns of the above table, a certain amount of connection appears between the strength of the following beat and the length of the pause or interval after the extra contraction. But this connection seems to be comparatively loose. On the whole the stronger beats follow the longer pauses. This dependence comes out clearly within the limits of short series of cases. In some series I made the extra contractions all equally early; the pauses after them varied, and the height of the following beat was plainly seen to vary directly with the length of the pause.

In order to determine with more certainty the degree to which the strength of the beat following the extra contraction was dependent on

¹ The re-grouping of the cases is not superfluous, since it diminishes the danger of founding a conclusion on a chance combination of cases. To rearrange the cases in this way may be as valuable as to add a considerable number of fresh cases.

each of the two factors mentioned — the earliness of the extra contraction, and the duration of the pause — I have had recourse to the mathematical treatment of correlation devised by Karl Pearson.¹ I have calculated Pearson's *coefficients of correlation*. On correlating the interval *before* the extra contraction with the height of the following beat, the coefficient was found to be 0.64. On correlating the interval *after* the extra contraction with the height of the following beat, the coefficient was 0.45. To get some meaning from these numbers, it is sufficient to know that a coefficient of unity would mean absolutely perfect correspondence, while a coefficient of zero would mean a complete lack of correspondence. The coefficient 0.64 accordingly denotes a fairly high degree of correspondence, and the coefficient of 0.45 only a moderate correspondence. To return to physiological terms: the strength of the following beat is closely dependent on the earliness of the extra contraction, and somewhat loosely dependent on the length of the pause.²

Statistical treatment thus confirms the observations made on typical cases, and removes all doubt as to whether those cases were really typical. This later treatment has brought again into view the same two factors in the determination of the force of contractions that were noted in a simpler form in the staircase contraction. The fact that the beat following an extra or hastened contraction is stronger than the preceding regular beat is a fresh example of the staircase effect. A long pause following an extra contraction also increases the force of the next beat. Usually, however, in the apex preparation, the pause is not prolonged, and therefore the strengthening of the next beat must be for the most part a result of the hastened extra contraction.

Before finally accepting this view, we ought to consider one other possibility. The strength of the beat following an extra contraction might be an after-effect of the weakness of that contraction. It has indeed been suggested that the following beat simply *compensates* for the weak extra contraction. Against this view must be placed the fact brought out earlier in this study, that a hastened contraction need not be subnormal in strength in order that the following con-

¹ A convenient reference is PEARSON'S *Grammar of Science*, 2d ed., 1900, p. 400.

² It is important to recall here that the earlier the extra contraction comes, the shorter in general is the following pause. Yet an early extra contraction and a *long* pause both strengthen the following beat. These two influences, though similar in effect, must be quite independent of each other.

traction be exaggerated. A consideration of such cases leaves no doubt that the hastening of the extra contraction is the principal factor in the result.¹

The view that the great strength of the beat following the extra contraction is simply a *compensation* for the weakness of the extra contraction, must at all events be definitely abandoned. The following beat often more than compensates, and its strength is hence not accounted for in terms of compensation. Good examples of *over-compensation*² are seen in Fig. 4.

Over-compensation usually comes still more plainly into view when several beats following the extra contraction are observed. The excessive height often continues for a number of beats, as in Figs. 4,

¹ The correlation method does not help us much here, because the force of the extra contraction is itself so closely dependent on the interval that precedes it, that if one be closely related to the force of the following beat, so must the other be as well. In fact, the coefficients are so nearly the same, 0.64 and 0.66, that no inference can be drawn, except this, that if we, on other grounds, admit the dependence of the following beat on the earliness of the extra contraction, we are sure that the weakness of the extra contraction has no considerable further effect of its own. For if it had, it would show a considerably higher coefficient of correlation, due to the combination of two causes of correspondence.

² In order to obtain a *measure* of the over-compensation, it would be necessary to add the force of the extra contraction to the force of the following beat, and compare the sum with the combined force of two regular beats. Unfortunately, it is difficult if not impossible to get an accurate measure of the force of the extra contraction from such tracings as are seen in Fig. 5. The actual recorded rise of the writing point evidently does not represent the full force of the extra contraction, since much of this force was consumed in overcoming the inertia of the descending lever and muscle. On the other hand, the total height of the extra contraction, measured from the base line, is often too great to represent the force, as in Fig. 6. Not being able to devise an accurate measure, I have nevertheless used the actual recorded rise of the extra contraction as a representative of its force. I chose this measure, because it was the most unfavorable to the result that seemed likely to appear; if then the result still appeared, it was certainly not manufactured. Using this measure, I found the sum of the extra contraction and the following beat to average 98 per cent of the sum of two regular beats: and when it is considered that the first extra contraction in Fig. 5 was counted as having but one-fourth of the force of a regular contraction, and that the second was counted as having no force at all, and further that the same deficiency is present in the majority of cases, it is certain that this 98 per cent should be increased to over 100 per cent, and indicate over-compensation. In a large share of the separate cases, even my defective measure showed over-compensation amounting to 20, 50, 70, and even as high as 175 per cent of the force of two regular beats. The separate cases, without regard to the average, are enough to show that nothing like an accurate compensatory function is in play, and that something more powerful than compensation is acting.

8, and 9. A comparison of these with Fig. 1 leaves little room for doubt that both represent the same fundamental fact, viz., the stimulating influence of hastened contractions.

In order to determine with certainty whether the extra contraction does act as a momentary stimulant of the heart muscle, it is necessary to consider both the force and the rate of the following beats. If the force were increased but the rate slackened, the resultant effect might be that less force was exerted in a given time. In order to bring both force and time into a single expression, the total force exerted in a given time may be divided by the time, thus giving a measure of the *force exerted per unit of time*. This quotient gives, in other words, a measure of the rate at which available potential energy is developed by the muscle. No other way of measuring stimulation or depression of the cardiac muscle is so complete as this.

In calculating this quotient, the interval *preceding* each beat should be counted as corresponding to that beat, since this is the time during which the energy discharged in that beat is accumulated. The intervals would most suitably be measured from the beginning of diastole to the end of the next systole, but as this measurement cannot be accurately made in my tracings, I have measured all intervals from the beginning of systole to the beginning of the next systole.

When the force per unit of time is thus measured, the stimulating effect of the extra contraction appears very plainly. My measurements show the following average results:

1. The force exerted by the first beat after the extra contraction amounts, per unit of time, to 142 per cent of the force exerted in the preceding regular contractions. In other words, during the diastole

and pause succeeding the extra contraction, the rate of development of energy is nearly $1\frac{1}{2}$ times the regular rate.

2. This stimulating effect of the extra contraction is not exhausted by the first following beat, but persists for several beats, about 8 or 9 on the average. This can be seen by reference to Fig. 10.

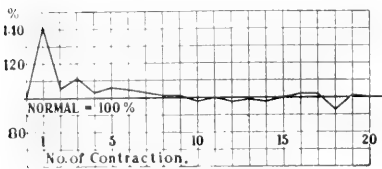

FIGURE 10.—Force exerted per unit of time by each of the first 20 beats following the extra contraction. Average measurements.

3. As the same figure also shows, the stimulation is not followed by an equal depression. The force per unit of time returns to normal after about ten beats, and may then sink a little below normal, but not

much below. In some instances the stimulating effect of several successive extra contractions persists for many beats, indeed almost indefinitely. The stimulating action of an extra contraction is, therefore, real and uncompensated, or at least not promptly compensated.

4. The stimulating action of an extra contraction is the stronger, the earlier the preceding diastole is interrupted by the extra contraction. This could be inferred from previous results, since it was found that the earlier an extra contraction came, the shorter was the following pause, and yet the stronger was the next beat. In order to get a measure of this relation, I have correlated the length of the interval before the extra contraction with the rate of development of potential energy during the following pause, measured by dividing the height of the following systole by the duration of the interval after the extra contraction. Both the interval before the extra contraction and the force per unit of time of the next beat are expressed as fractions per cent of the regular values obtained from the preceding beats.

Interval before extra. Per cent.	Number of cases.	Force per unit of time, exerted by the next beat. Per cent.
-39	15	168.9
40-49	18	158.2
50-59	30	151.8
60-69	34	148.5
70-79	16	116.4
80-	19	104.3

The shorter the interval before the extra contraction, then, the more is the development of energy accelerated immediately afterward. The more the extra contraction is hastened, the greater is its effect as a stimulant.

The converse statement also holds good, as is seen by re-grouping the cases; that is to say, where we find an especially strong stimulation resulting from an extra contraction, there we find the extra contraction to have come especially early.

That the connection between the earliness of an extra contraction

and its stimulating effect is close appears also from Pearson's coefficient of correlation, which in this case is 0.73.

Force per unit of time exerted by beat after extra contrac- tion. Per cent.	Number of cases.	Interval before extra. Per cent.
-99	28	69.5
100-119	24	66.7
120-139	18	58.1
140-159	12	58.0
160-179	22	53.9
180-199	12	49.1
200-	16	49.1

Finally, in order to get back from numbers to the cardiac muscle, attention may be directed again to Fig. 3, in which the main results of my measurements find a concrete illustration. On comparing the spontaneous beats before and after the series of extra contractions, the stimulating effect of hastened contractions is clearly seen, and has obviously no resemblance to compensation.

By running the eye along the series of extra contractions, the connection of this stimulating effect with the staircase phenomenon becomes apparent, as well as the strengthening effect of a pause or prolonged diastole on the following contraction. No doubt can remain of the reality of these factors, and of their adequacy to explain the variation in force of contraction that appears on electrical stimulation of the ventricular apex.

II. EXPERIMENTS ON THE FROG'S HEART.

As the experiments to be reported here were devised in the hope of clearing points still under dispute, I shall introduce them in the midst of a discussion of the literature. The results obtained in the apex and base preparations will also be found to have con-

siderable theoretical importance. I shall confine the discussion to a few questions, which the facts in hand would seem to settle definitely.¹

THE REFRACTORY PERIOD.

Marey, who in 1876 discovered the refractory period of the normally beating frog's ventricle, gave the following account of it.² The refractory period was in the main coincident with the early part of systole. During the relaxation or diastole, the ventricle responded to a stimulus by an extra contraction; during systole it gave no response whatever, either by an extra contraction or by increased strength of the systole then in progress. This refractory period was not, however, according to Marey, of constant length, but shrank as the stimulus was strengthened, being gradually reduced to the first instants of systole, and finally, on the application of fairly strong stimuli, disappearing altogether. The response to strong shocks applied early in systole consisted, not in any increased height of the contraction then in progress, but in an extra contraction, which began late in the following diastole. The latent period of the extra contraction, which was

¹ The apparatus used for recording the movements of the frog's heart was patterned more or less after the "Fühlhebel" used by KAISER (*Zeitschrift für Biologie*, 1892, xxix, p. 208). The movements of the auricle or ventricle were first received by a vertical piece of grass straw. The cut end of the straw rested directly on the auricle or ventricle. A small distance from the end of the straw a little opening was made into its central cavity and filled with paraffin, thus making the straw air-tight and helping out adhesion by suction. This vertical straw was attached to the horizontal lever—also a piece of grass straw—by means of a pin which served as a pivot on which the vertical straw could turn freely. I did not find it necessary to provide a guide for the vertical straw. The same object—adhesion to the heart—was secured by pinning the apex of the ventricle to a thin plate of cork inserted beneath it. The pin served also as an electrode, the other pole being provided by another small pin close to the first, and either piercing the apex or fixed in the cork close beside it. When the auricle was to be stimulated, a pin was passed through the left margin of the left auricle into the cork beneath, and another was fixed in the cork in contact with the auricle. The pin through the ventricular apex had in this case no electrical connection. The pins can be inserted with little loss of blood.

On the whole, I do not regard this method as equal to that of suspension; it wears out the heart more quickly. Still it gave satisfactory results, and enabled the stimulus to be very sharply localized.

² MAREY: *Travaux du laboratoire*, 1876, pp. 73 ff.

but a small fraction of a second when the stimulus was applied in diastole, was sometimes a whole second when the stimulus came early in systole.

This extreme length of the latent period was a suspicious circumstance. Almost immediately Hildebrand¹ suggested that the extra contraction that followed a strong stimulus applied to the ventricle during systole was not a direct response of the ventricle, but was due to a leakage of current to the auricle. Since, during systole of the ventricle, the auricle is in diastole and therefore irritable, leakage would, if strong enough, call forth an extra contraction of the auricle, and this, in the regular progress of the wave of contraction, would be followed by an extra systole of the ventricle.

This explanation has so much in its favor that it has won the assent of many special students of the subject,² yet the description and tracings of Marey have remained classic.

All the evidence is in favor of Hildebrand's suggestion; it may be summarized as follows:

(1) In Marey's experiments the stimulating electrodes were apparently applied to the base of the ventricle, so that spread of current to the auricle was very probable. Hildebrand³ and later Engelmann⁴ found that when the electrodes were applied near the apex, much stronger shocks than those employed by Marey were necessary in order to get an extra contraction by stimulation during systole. I have confirmed this result.

(2) The extra contraction elicited by stimulation during systole comes at the same time and gives the same ventricular tracing as when the auricle is stimulated during ventricular systole. In other words, the result obtained is exactly what the hypothesis of Hildebrand would require. This is strong circumstantial evidence.

(3) The direct evidence is even clearer. On recording simultaneously the movements of the auricle and of the ventricle, it is found that the first effect of the strong stimulus applied to the ventricle during its systole is actually an extra contraction of the auricle. This is then followed as usual, and at the usual interval, by an extra contraction of the ventricle. These facts are seen in Fig. 11, which is

¹ HILDEBRAND: Nordiskt medicinskt Archiv, 1877, ix. See also LOVÉN, Mittheilungen vom physiologischen Laboratorium in Stockholm, 1886, i, p. 4.

² As, e.g. ENGELMANN: Archiv für die gesammte Physiologie, 1895, lix, pp. 316-321; KAISER: Zeitschrift für Biologie, 1892, xxix, pp. 215, 217.

³ HILDEBRAND: *Op. cit.*

⁴ ENGELMANN: *Op. cit.*

similar to some given by Engelmann,¹ but is easier to follow, because auricle and ventricle are recorded separately.²

(4) It only remains to make sure that the extra contraction of the auricle, that occurs on exciting the ventricle during its systole with strong shocks, is actually due to escape of current. This is demonstrated by the following simple experiment.

A frog's heart is excised and laid on a slab of cork; pin electrodes are fixed in the ventricular apex. The strength of current is determined that is just sufficient to cause an extra contraction of the

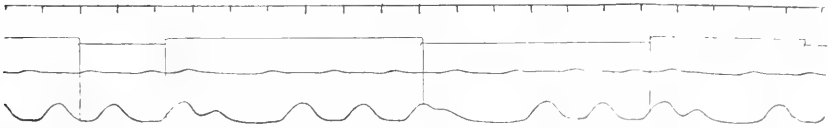

FIGURE 11.—Frog's heart. Record of auricle above and of ventricle below. Read from left to right. Time in seconds. Primary current, 6 volts. Distance of secondary coil, 0. In the record of stimuli, down means make; up, break. Stimulus applied to apex of ventricle.

The first and third shocks fell during the irritable period of the ventricle, and called out direct ventricular response. The third fell also during the irritable period of the auricle, but, being a make, was not strong enough to cause by leakage an auricular extra contraction. The second and fourth shocks (breaks) fell during the refractory period of the ventricle, but called out extra contractions of the auricle, which were followed by extra contractions of the ventricle.

auricle (and ventricle) when applied to the apex at any particular stage of auricular diastole. Then, with a sharp knife, auricle and ventricle are completely severed, but left in contact in the same position as before. Now the same current, applied to the apex at the same

¹ ENGELMANN: *Op. cit.*, pp. 320, 321.

² BRUNTON and CASH: (Proceedings of the Royal Society of London, 1883, xxxv, p. 460) also publish a tracing, which, though not intended for this demonstration, is as appropriate as could be wished. The tracings in their paper are full of examples of the leakage of current from one chamber of the heart to another, though the authors take scant notice of this source of strange results. Curiously enough, after they have once remarked that "these results may be due, in part at least, to escape of current," they take so little further account of this possibility as to conclude from the occasional prompt response of the ventricle, without long latent period, to stimulus applied to the auricle, that the impulse to contraction is conducted by means of nerves, and that, therefore, besides the regular muscular conduction of impulses in the heart, there must be a nervous conduction. Much more probable, since it was only strong currents that called out the prompt response of distant parts of the heart, is the supposition that the conduction was purely electrical.

stage of auricular diastole as before, calls out still an extra contraction of the auricle. (Naturally, no contraction of the ventricle here follows that of the auricle.) Since in this preparation no physiological conduction of any sort remains between auricle and ventricle, we can fall back on no other hypothesis but that of escaped current. And since the same strength of current gives the same auricular response, either with or without physiological connection, we must suppose leakage to be the cause in both cases.

A similar experiment shows that the disappearance of the refractory period that Marey observed on warming the heart, is likewise the result of escape of current to the auricle. For on watching the auricle, it is seen that warming it enables it to respond to a somewhat weak current applied to the apex; and the same if auricle and ventricle are severed. What warming accomplishes is an increased irritability of the auricle, so that the leakage of feebler currents is effective.

Hildebrand's suggestion is thus demonstrated. The extra contraction of the ventricle that is obtained by stimulating it strongly during systole is not a direct response to the electrical shock. There is nothing to indicate that the ventricle is any less than absolutely refractory during systole. The dog's apex, as we saw, is absolutely refractory during that phase. The end of the refractory period, in the dog's apex, was marked by the very summit of the myogram; and practically the same limit has been assigned by Engelmann¹ to the refractory period of the frog's heart, and by Cushny and Matthews² to that of the intact mammalian heart. In short, cardiac muscle is, during systole, entirely unirritable.

The refractory period is clearly of a piece with the law of "all or none;" both point to the same peculiarity of cardiac muscle. The existence of the systolic refractory period means that the spontaneous beats, as well as electrically excited contractions, are maximal.³ The lobster's heart, which does not show the law of all or none, also fails to show any refractory period.⁴ The existence of an absolutely re-

¹ ENGELMANN: *Archiv für die gesammte Physiologie*, 1895, lix, p. 315.

² CUSHNY and MATTHEWS: *Journal of physiology*, 1897, xxi, p. 219. Also GLEY: *Archives de physiologie*, 1889, p. 503.

³ This view has been well expressed by KAISER (*Zeitschrift für Biologie*, 1892, xxix, p. 218), and by CUSHNY and MATTHEWS (*loc. cit.*).

⁴ HUNT, BOOKMAN, and TIERNEY: *Centralblatt für Physiologie*, 1897, xi, pp. 275 ff., especially Figs. 1 and 7. Compare also KAISER's results with frog's hearts treated with muscarin, *Zeitschrift für Biologie*, 1892, xxix, p. 219.

fractory period during systole could be inferred and predicted from the law of maximal contraction, wherever that law holds.

Not to be predicted from the law of "all or none," however, is the fact that a stimulus applied during systole has no effect on the irritability or on the development of contractile energy, during the following diastole. As far as concerns the irritability, this statement is demonstrated by Fig. 12. If a shock applied during systole raised the irritability of the muscle during the following diastole, then a series of shocks begun in systole and lasting on into diastole should produce an extra contraction earlier than it could be produced by a single shock applied in diastole. But no such result appears; the single

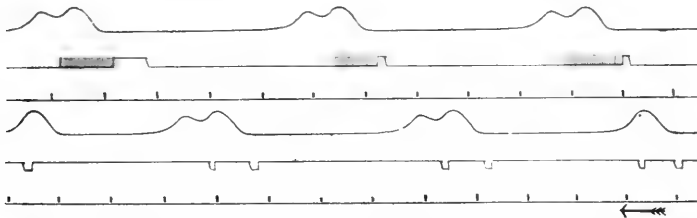

FIGURE 12. — Stimulus and record of frog's ventricle. Read from right to left. Time in seconds. Primary current, 2.2 volts. Distance of secondary coil, 100 mm. Down = make, up = break. Rate of faradization, 34 make-breaks per second. The upper curve was traced about a minute and a half after the lower.

shock is as efficient as the series. I have varied this experiment by using a single strong shock during systole and following it by a weak shock in diastole; the former had no influence on the efficiency of the latter. A shock that reaches the muscle during the refractory period leaves no appreciable after-effect on the irritability.

It is the same with contractility.¹ A stimulus applied during the refractory period has no effect on the force of the next following contraction. I have applied strong shocks to the frog's ventricle, and also to the dog's apex, during each successive systole for a number of beats, without affecting the height of contractions in the least. The development of available energy is not affected by a stimulus during the refractory period. Such a stimulus is in every respect as devoid of effect as if it had not occurred.

The account of the irritability during the cardiac cycle would not be complete if we spoke of the systole as a refractory period, and opposed to it diastole and pause as an irritable period. For though no

¹ Cf. ENGELMANN: *Archiv für die gesammte Physiologie*, 1896, lxxv, p. 139.

portion of this latter period is absolutely refractory, yet, at its beginning, only strong stimuli take effect, whereas later on in diastole weak stimuli are sufficient. The irritability increases gradually from the beginning of diastole on. Bowditch¹ showed that even 3, 4, or 5 seconds after the commencement of diastole, the frog's apex had not yet reached its maximum of irritability. The rapid gain during the early part of diastole has been demonstrated by Engelmann² in the frog, by McWilliam³ and by Cushny and Matthews⁴ in the intact dog's heart; and I have found the same in the mammalian apex preparation, both after spontaneous and after electrically excited contractions. The stronger the stimulus, the earlier in diastole can it be successfully applied.

It is inaccurate to speak of the refractory period as of variable length, extending on into diastole when the stimulus is weak. The refractoriness that obtains during systole, and the low irritability early in diastole, are two quite different phenomena. The one is absolute, the other relative. The one is a corollary of the law of "all or none," the other has no such dependence. The low irritability during relaxation appears in muscular tissue that shows no law of "all or none" and no refractory period during contraction, — such, for example, as the smooth muscle of the frog's stomach.⁵

The refractory period, being peculiar to cardiac muscle, is significant of its fundamental properties. But the low irritability early in diastole, though not specially significant in this respect, is the more important fact in explaining certain other peculiarities of the muscle, such as its response to a tetanizing current by a series of rapid beats (see above, page 216), or such as the compensatory pause.

THE COMPENSATORY PAUSE.

The first fact to be borne in mind in attempting to explain the compensatory pause is that such a pause does not follow an extra contraction of a *spontaneously* beating piece of the heart. Whether the piece be from the apex or base of the dog's ventricle, as in my

¹ BOWDITCH: Arbeiten aus der physiologischen Anstalt zu Leipzig, 1871, pp. 150, 151. This result has been confirmed by ÖHRWALL: Skandinavisches Archiv für Physiologie, 1898, viii, pp. 37-40.

² ENGELMANN: Archiv für die gesammte Physiologie, 1895, lix, p. 315.

³ MCWILLIAM: Journal of physiology, 1888, ix, p. 170.

⁴ CUSHNY and MATTHEWS: Journal of physiology, 1897, xxi, p. 215.

⁵ See WOODWORTH, This journal, 1899, iii, p. 39.

experiments, or from the sinus¹ or great veins² of the frog, whether it contain ganglia or not, the result is the same: no compensatory pause follows the extra contraction. In some cases, the pause after the extra contraction is somewhat prolonged, but it has not the accurate compensating length observed in the intact heart; usually it is much too short to compensate, and in the perfused dog's apex it averaged less than the regular pause.

A similar fact is that a piece of the heart beating in response to a *constant stimulus* does not show the compensatory pause. This again is true without regard to the presence or absence of ganglia.³

It is not safe to infer from these two facts that the internal stimulus producing the spontaneous contractions is constant. What the two cases have certainly in common is this: in both, the rhythm of a piece of heart is developed within that piece.

When, on the contrary, the rhythm of a piece of heart is impressed upon it by rhythmic stimuli from beyond, then an extra contraction is followed by a compensatory pause. The same piece of muscle, or of muscle and ganglia, which showed no compensatory pause when beating spontaneously or in response to a constant stimulus, will show the pause when beating in response to rhythmic stimuli.

As an example of this, an experiment of Engelmann⁴ may be

¹ TIGERSTEDT and STRÖMBERG: Mittheilungen vom physiologischen Laboratorium in Stockholm, 1888, pp. 31, 32.

² ENGELMANN: Archiv für die gesammte Physiologie, 1896, lxxv, p. 137, p. 140.

³ ENGELMANN: Archiv für die gesammte Physiologie, 1895, lix, pp. 328, 329. The statement made by LANGENDORFF (Archiv für Physiologie, 1884, Supplement-Band, p. 59; and 1885, p. 285) and repeated by KAISER (Zeitschrift für Biologie, 1895, xxxii, p. 457), that during constant stimulation of the entire but isolated frog's ventricle an extra contraction is followed by a compensatory pause, is, I am convinced, a mistake, the cause of which is not far to seek. In order to avoid injury to the ganglia in the base of the ventricle, the cut or clamp by which the ventricle was isolated would naturally be placed a little *above* the auriculo-ventricular groove. From the authors' descriptions, it is clear that this was at least sometimes the case. The constant chemical or mechanical stimulus, which was applied at the base of the ventricle, acted directly on the small remnant of the auricle. The pulsation of the ventricle would then be aroused by the auricle, and not directly by the artificial stimulus. The same remark applies to the spontaneous contractions which the authors sometimes observed. They probably originated in the auricle. This interpretation has at least sufficient probability to make LANGENDORFF'S and KAISER'S result of small weight as compared with the mass of facts on the other side.

I am under the impression of having read this criticism in one of ENGELMANN'S papers, but cannot now find the passage.

⁴ ENGELMANN: Archiv für die gesammte Physiologie, 1895, lix, p. 326.

quoted. He excited a quiescent frog's apex¹ to rhythmical contraction by means of stimuli succeeding each other at about the rate of the normal heart beat. He then secured an extra contraction by interpolating an extra stimulus. After the extra contraction, one of the periodic beats failed to appear, and the apex remained at rest until the next of the rhythmic stimuli reached it.

The result of this simple experiment of Engelmann could have been foretold with certainty. It shows nothing new regarding the properties of the cardiac muscle. But it does serve to throw into relief the conditions necessary for the development of a compensatory pause. These are, first, the low irritability at the beginning of the diastole, which prevents a stimulus following quickly upon the extra contraction from taking effect, and thus cuts out one regular beat; and second, the absence of spontaneous contractions or of a constant stimulus.

I have repeated Engelmann's experiment on the mammalian apex, with one modification which makes the conditions approach more nearly to those of the normally beating ventricle. I took an irritable but non-spontaneous piece of apex, cut it nearly in two, and tied a ligature, not too tightly, about the narrow bridge that connected the two portions. On applying a stimulus to one portion, I obtained first a contraction of this portion, and then, after a perceptible interval, a contraction of the other portion.¹ I then obtained a series of such contractions, and into this series interpolated, by stimulation of the second portion, an extra contraction of that portion. The next periodic contraction failed to spread across the bridge into the second portion, the latter remained quiet till the following periodic contraction occurred, thus showing a compensatory pause.

This latter experiment is a very close counterfeit of what doubtless occurs in the normally beating heart after an extra contraction. We have abundant reason, from the work of Gaskell and of Engelmann, to believe that the regular beats of the ventricle are aroused by as many waves of excitation that come down from the auricle (and ultimately from the sinus and great veins). The low irritability immediately after the extra contraction prevents the ventricle from responding to one auricular stimulus; and as the ventricle is not

¹ So far, this is simply a repetition on the mammalian ventricle of a familiar experiment of GASKELL on the cardiac muscle of amphibians. See *Journal of physiology*, 1883, iv, p. 64, and SCHÄFER'S *Text-book of Physiology*, 1900, ii, pp. 180, 182.

beating spontaneously, and is not subject to a constant stimulus, it remains quiet till the next auricular stimulus, and so shows a compensatory pause.

One or two more experiments throw light on the compensatory pause. The first concerns the irritability of the heart muscle during the pause. Engelmann¹ conjectured that the curve of returning irritability after the extra contraction would run about the same course as after a regular contraction; possibly, he thought, the return of irritability would be somewhat slower after the extra contraction. Cushny and Matthews,² working on the intact mammalian heart, found this slower return of irritability present to a certain degree, though not to a sufficient degree to account for the full length of the compensatory pause. In my preparations, I have not found it present at all. A given strength of stimulus can elicit an extra contraction just as early in the diastole of an extra contraction as in that of a regular contraction, or even a little earlier. The easiest way of testing this matter is by applying a faradic current during a regular contraction, and continuing it during the extra contraction until a second extra contraction arises. The result appears in Fig. 9 (dog's apex), and in exactly similar tracings from the intact frog's ventricle.

The prolonged inactivity of the ventricle after an extra contraction is not due to a lack of contractility nor to a lack of adequate irritability, but simply to the lack of a stimulus. The compensatory pause is not a period of inhibition, but a period of waiting. If a constant stimulus of only moderate strength were present, it would take effect before the end of the compensatory pause. If the ventricle were beating spontaneously, it would usually develop within itself an adequate stimulus before the end of that time.

Another valuable experiment consists in exciting two or more extra contractions, one following immediately after the other, and studying the effect on the pause. After Engelmann's³ work on this line, there would be little excuse for returning to it, had not Kaiser⁴ confused the matter by an incomplete and misleading account, accompanied by tracings which, taken alone, seem to support an incorrect view.

¹ ENGELMANN: *Archiv für die gesammte Physiologie*, 1895, lix, p. 328.

² CUSHNY and MATTHEWS: *Journal of physiology*, 1897, xxi, p. 220.

³ ENGELMANN: *Archiv für die gesammte Physiologie*, 1895, lix, pp. 330 ff.

⁴ KAISER: *Zeitschrift für Biologie*, 1895, xxxi, p. 455.

Kaiser's statement is that the length of the pause increases with the number of consecutive extra contractions. A glance at Figs. 13 and 14 will show that this is at least not always true. I have never found it true, either in the dog's apex or in the intact frog's ventricle.

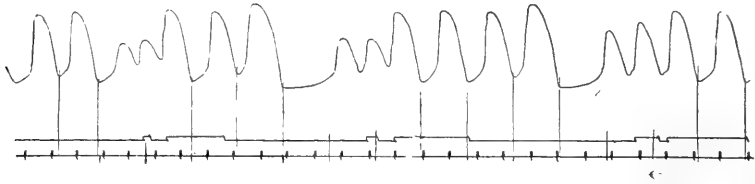

FIGURE 13. — Frog's heart. Stimulation and record of ventricle. Three-fifths the original size. Read from right to left. Time in seconds. Primary circuit, 1 Daniell. Distance of secondary coil, 80 mm.

Kaiser himself admits that he found it true only within limits, but he makes light of the limits. Kaiser also asserts¹ that the pause following two extra contractions will be the longer, the more quickly they come, because, according to his views, their inhibitory after-effect will thus be more completely summated. Fig. 13 puts this matter straight. Two extra contractions are likely to cut out two regular beats, and the pause after them may then be long as compared with the ordinary compensatory pause, and it will be longer the earlier the extra contractions come. But it is possible to make two extra con-

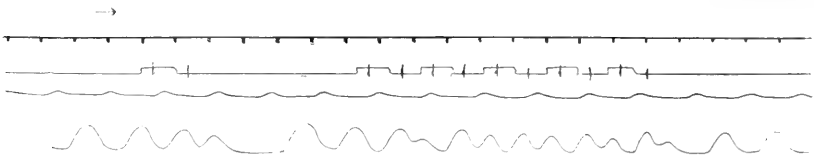

FIGURE 14. — Frog's heart. Stimulus applied to ventricle. Record of auricle above, of ventricle below. Time in seconds. The moments of stimulation indicated by the electromagnet needed to be displaced to the right, and the true moments are indicated by short vertical scratches across the magnet tracing.

tractions come so early that only one regular beat shall be cut out, the irritability being already sufficiently restored, after the second extra contraction, to permit the second auricular stimulus to take effect. In this case, the pause is even shorter than the regular pause between beats.

The only rule governing the length of the pause after multiple extra contractions, is that given by Engelmann,² namely, that the first

¹ KAISER: *Op. cit.*, p. 456.

² ENGELMANN: *Loc. cit.*

regular beat after the pause comes at one of the regular beat periods. This fact, and the reason for it, are well illustrated in Fig. 14. Each regular beat of the ventricle is there the sequel to a beat of the auricle. During the stimulation and extra contractions of the ventricle, the auricular beat goes on undisturbed, but has no effect on the ventricle. When the extra contractions have ceased, the auricular beat has once more its ventricular sequel, and both chambers go on beating as if nothing had happened.

Viewed in this way, the restoration of the regular times of beat, after an extra contraction, is a simple matter and not very fundamental. When the times of the ventricular beat are disturbed, the ventricle does not of itself regain them, but waits passively on the auricle, whose beats, in such a case as Fig. 14, have not been disturbed. If the auricle has been disturbed, it can wait passively on the coming of the rhythmic stimuli from the sinus. But if the beat of the sinus is disturbed by an extra contraction, there is no compensatory pause and no restoration of the regular times of beat;¹ the situation is here the same as in the spontaneously beating dog's apex: the extra contraction affects the place of origin of the rhythmic stimuli and disturbs their sequence. Whenever the regular times of beat are restored after an extra contraction, it is because the disturbance has not affected the source of the normal rhythmic stimuli. The "Law of the Preservation of the Physiological Moments of Stimulation,"² as Engelmann terms it, is not, therefore, a fundamental property of the heart muscle or of the ganglia; it is not worthy to be classed with the law of maximal contractions, or with the low irritability during diastole, or with the spread of the excitation wave from sinus, through auricle, to ventricle; it is simply a result of these fundamental properties of cardiac muscle.

This view of the compensatory pause to which our summary of facts has led us is the view of Engelmann and also that of Gaskell.³ The restoration of the regular moments of beat after one or more extra contractions is so readily and completely explained by Gaskell's theory of the heart beat as to constitute a strong argument in favor of that theory.

¹ TIGERSTEDT and STRÖMBERG: *Mittheilungen vom physiologischen Laboratorium in Stockholm*, 1888, pp. 31, 32; ENGELMANN: *Archiv für die gesammte Physiologie*, 1896, lxxv, p. 137.

² "Gesetz der Erhaltung der physiologischen Reizperiode." ENGELMANN: *Archiv für die gesammte Physiologie*, 1895, lxxix, p. 333.

³ GASKELL in SCHÄFER'S *Text-book of physiology*, 1900, ii, p. 191.

A new fact in support of that theory is the absence of a compensatory pause in case of a spontaneously beating piece of the ventricle, whether from the apex or from the base. Since ventricular muscle does not show the pause when its beats are certainly spontaneous, the probability is that in the normal heart beat, when the ventricle shows the compensatory pause, the reason is that the ventricle is not then spontaneous.

The facts brought together in the preceding pages enable us to throw out at once all other views of the compensatory pause that have been suggested.

In opposition to the view¹ that the ganglia are necessary for the production of the pause, we have the fact that, given like conditions of stimulation or of spontaneity, the presence or absence of ganglia makes no difference in the result.

In opposition to the view that the pause is some sort of a compensatory² or inhibitory³ after-effect, we have the fact that two or more extra contractions are not as a rule followed by a longer pause than one, and not necessarily by any prolonged pause at all; and also the fact that tests of the irritability and contractility during the pause betray little or no sign of inhibition.

The theory of the pause that regards it as an inhibitory after-effect of the extra contraction has been elaborately worked out by Kaiser.⁴ He regards the regular diastole also as an inhibitory after-effect of systole. The stronger the cause, his argument runs, the stronger must be the effect; and hence an extra contraction, following quickly after a regular beat, must, by summation, produce more than the usual diastole and pause. An excellent opportunity of testing Kaiser's theory in general is afforded by the contraction that follows the compensatory pause. This contraction is usually stronger than the regular systole, and should therefore, according to the theory, be followed by an especially complete diastole and a prolonged pause. This, however, is never the case. On the contrary, the diastole is practically always incomplete or the pause shortened. When the extra contraction is followed by an alternation of strong and weak beats, or in any other case of such alternation, the strong beats are regularly followed by less diastole and pause than the weak beats.

¹ DASTRE: *Journal de l'anatomie et de la physiologie*, 1882, pp. 464, 465.
KAISER: *Zeitschrift für Biologie*, 1895, xxxii, p. 446.

² MAREY: *Travaux du laboratoire*, 1876, p. 74.

³ KAISER: *Loc. cit.*

⁴ KAISER: *Loc. cit.*

On the basis of my tracings (*e. g.* Figs. 3, 5, 13), as well as of all others I have seen, including those of Kaiser,¹ I can most definitely deny that the pause following a contraction shows any tendency to be proportional to it. The conclusion is, therefore, not only that the compensatory pause is no inhibitory after-effect of the extra contraction, but that diastole, in general, is not an inhibitory after-effect of systole.

To sum up: The compensatory pause is not the expression of any compensatory function exerted by cardiac muscle or ganglia; and it is not a period of inhibition; it is simply a period of waiting for a stimulus. The conditions necessary for its appearance are:

1. The absence of spontaneous contractions from the portion of the heart that shows the pause; and the absence of any constant stimulus directly affecting that portion.

2. The excitation of that portion by rhythmic stimuli coming from beyond itself.

3. The refractory period occupying the systole of the extra contraction and the low irritability early in its diastole; one or another of these causes prevents one of the rhythmic stimuli from taking effect after an extra contraction.

4. The freedom of the sinus, or in general of the portion of the heart muscle in which the rhythmic stimuli originate, from disturbance by the artificial stimulus or by the extra contraction.

THE FORCE OF CONTRACTION.

Two facts demand an explanation:

1. The extra contraction is always weak in comparison with the regular beat, and it is weaker the more closely it follows the preceding regular beat.

2. The beat after the extra contraction and pause is stronger than the regular beat.

The first of these facts is visible in every tracing from Marey down. The second, for some reason, does not appear in the tracings of some authors. It was first noted by Langendorff² in the frog's heart, and has been remarked also by Kaiser³ and by Bottazzi⁴ in batra-

¹ KAISER: *Zeitschrift für Biologie*, 1892, xxix, Taf. IV; 1895, xxxii, Taf. VI.

² LANGENDORFF: *Archiv für Physiologie*, 1885 p. 287.

³ KAISER: *Zeitschrift für Biologie*, 1892, xxix, p. 216.

⁴ BOTTAZZI: *Centralblatt für Physiologie*, 1896, x, pp. 403, 404.

chians, by Bottazzi¹ in the embryo chick, and in mammals by McWilliam,² Gley,³ Langendorff,⁴ and Cushny and Matthews.⁵ My tracings show it in the frog's heart, and in the apex and base preparations from the dog's ventricle.

In regard to the weakness of the extra contraction, there can be no doubt of the correctness of McWilliam's⁶ suggestion, that insufficient *time* has elapsed since the end of the preceding systole to permit the accumulation of the regular amount of contractile force. On account of the maximal character of the contractions of cardiac muscle, no contractile force, no available potential energy, is present at the commencement of diastole; and it is only gradually accumulated. It continues to accumulate throughout the diastole and pause, as is seen by the increasing height of the extra contraction.

To explain the great force of the contraction following a compensatory pause, we naturally push the preceding explanation a little further.⁷ Since the contractility accumulates throughout the regular pause, it would very likely continue to accumulate if the pause were further prolonged, as is the case after an extra contraction. And, in fact, the longer the compensatory pause, the stronger is the following contraction.

In the earlier part of this paper, the length of the pause was proved to be a genuine factor in the production of a strong contraction. This factor alone, however, was found insufficient to account for the phenomenon in the apex and base preparations, since in them an extra contraction was not usually followed by a prolonged pause, and yet the next contraction was always exaggerated. The pause after an extra contraction was even found to average less than the regular pause, yet the following contraction averaged more than the regular contraction.

Another factor also was shown to be effective in increasing the height of a contraction. The hastening of a contraction had a stimulating effect on the force of the next beat or of several following beats. This was interpreted as being a form of the "staircase" phenomenon.

¹ BOTTAZZI: Archives italiennes de biologie, 1897, xxvii, pp. 121-123.

² MCWILLIAM, Journal of physiology, 1888, ix, p. 171.

³ GLEY: Archives de physiologie, 1889, p. 505.

⁴ LANGENDORFF: Archiv für die gesammte Physiologie, 1895, lxi, p. 317; and 1898, lxx, p. 473.

⁵ CUSHNY and MATTHEWS, Journal of physiology, 1897, xxi, 216.

⁶ MCWILLIAM: *Op. cit.*, p. 170.

⁷ MCWILLIAM: *Op. cit.*, p. 171.

The more the extra contraction was hastened, the stronger was the stimulating effect.

In order to look for this factor in the beat of the intact frog's heart, we must get rid of the compensatory pause after the hastened contraction. This can be done by interpolating a second extra contraction. The result can be seen in Fig. 13, and, with a greater variety of cases, in Fig. 15. The effect of the hastened contraction, without the pause, is seen to be practically nothing. The only visible factor in determining the force of a contraction is the length of the preceding pause.

Here, then, we encounter a wide divergence of results as between the frog's heart and the perfused dog's apex (or base). In the frog's heart, the length of the pause controls the force of the following contraction, and the after-effect of a hastened contraction is not visible. In the dog's apex, the pause has indeed its effect, but this is small in comparison with the effect of hastening a beat.

The cause of this difference can, I believe, be assigned. The dog's apex preparation almost always beats at a rate slower than its "optimal rate," as is proved by the fact that artificially hastening its rhythm, by a series of shocks, gives rise to a "staircase." The intact frog's ventricle, on the contrary, usually beats faster than its optimal rate; for artificially hastening its rate diminishes the force of its beat, whereas artificially slowing its rate increases the force. Artificial slowing, free from vagus inhibition, can be accomplished in the following way: It is known¹ that stimulation of the auricle, very early in its diastole, causes an extra contraction that does not spread to the ventricle. The

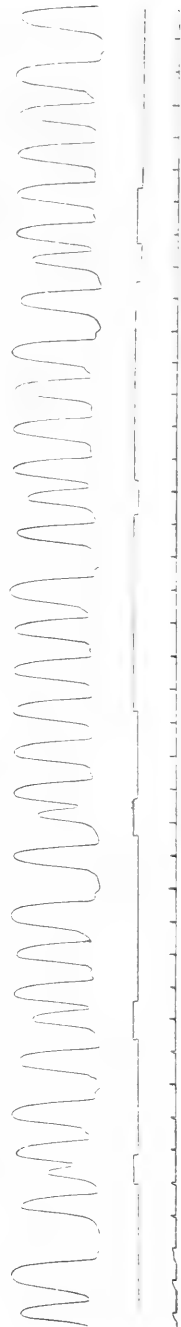

FIGURE 15. — Stimulation of the ventricle of the frog's heart. Time in seconds. Down = make, up = break. The little elevations between the large ventricular curves record the beats of the auricle.

¹ DASTRE: *Journal de l'anatomie et de la physiologie*, 1882, p. 464; KAISER: *Zeitschrift für Biologie*, 1892, xxix, p. 217.

auricle, and the ventricle with it, then miss one of the regular beats. If the auricle is again stimulated soon after its next regular beat, and so on, the result is that the ventricle beats at half its former rate, and that its beats are stronger. In one heart on which I tried this experiment, this form of ventricular beat, once started, kept on of itself, evidently because the prolonged ventricular contractions cut out every second auricular excitation. In this case, too, the slowed beat was stronger than the regular beat. McWilliam¹ has found that the mammalian ventricle, also, beats more strongly when the rhythm of the heart is artificially slowed without vagus inhibition.

Now since the ventricle of the intact heart beats faster than its optimal rate, the force of any contraction is more increased by prolongation of the preceding pause than by hastening the preceding contraction. And the contrary is the case in the perfused apex, because its spontaneous beats are slower than their optimal rate.

That a spontaneously beating portion of cardiac muscle should assume a rate slower than its optimum seems a pregnant fact; as yet, however, it stands too much alone to warrant an hypothesis.²

Besides the two factors mentioned above, several others have been suggested by different authors as determining the force of the beat following the extra contraction. The view of Gley,³ that the main factor is the distention of the ventricle by a double supply of blood, and the view of Bottazzi⁴ that a positive after-effect of vagus stimulation comes into play, are neither of them applicable to the apex preparation.

Langendorff⁵ regards the great force of the beat following the extra contraction as simply a compensation for the weakness of the extra contraction, and as having nothing to do with the length of the intervening pause. His view seems to be that the heart has some compensatory power, by virtue of which it necessarily follows up a weak contraction by a contraction that is correspondingly strong. He offers no evidence in support of his statement that the length of the

¹ MCWILLIAM: *Op. cit.*, p. 171.

² I have used the term "optimum rate" to mean such a rate as will make the *single* beats the strongest. The *sum total* of force exerted by cardiac muscle would probably be greatest at a faster rate than this, since we found the development of available energy to proceed fastest after the most hastened extra contractions.

³ GLEY: *Archives de physiologie*, 1889, p. 505.

⁴ BOTTAZZI: *Centralblatt für Physiologie*, 1896, x, p. 403.

⁵ LANGENDORFF: *Loc. cit.*

pause has nothing to do with the matter, and that statement has been abundantly disproved above, both for the frog's ventricle and for the dog's apex. It was also found that in the mammalian preparations the effect cannot be called compensation, but is rather actual stimulation.¹

Throughout this study, I have been unable to detect anything in the nature of an active compensatory function. All the facts, new and old, that have here been collected, tend to lessen the importance of the doctrine of compensation. Such compensation as occurs is merely incidental to the operation of the fundamental properties of cardiac muscle.

SUMMARY.

The perfused apex of the dog's ventricle shows the law of maximal contractions, or "all or none."

It shows also the refractory period, which extends throughout the systole of all contractions, and is not diminished in length by greatly strengthening the stimulus.

It shows also a gradual increase in irritability during diastole.

¹ LANGENDORFF's view leaves altogether out of account the law of "all or none," as applied to the extra contraction. This mistake can be seen in the following statement of his view (LANGENDORFF: *Archiv für die gesammte Physiologie*, 1898, lxx, pp. 480, 481):

"Kehren wir zur compensatorischen Systole [by which name he calls the strengthened beat following the extra contraction] des Ventrikels zurück. Vermuthlich ist ihre grössere Stärke dadurch bedingt, dass der Herzmuskel in gleichen Zeiten gleiche Energiemengen ausgibt, die künstlich hervorgerufene Systole aber nur einen mehr oder minder grossen Bruchtheil der disponiblen Spannkraft in Anspruch genommen hat. . . . Man kann aber überhaupt nicht mehr die vorausgehende längere Herzpause zur Erklärung der Pulsverstärkung herbeiziehen: denn wir wissen jetzt, dass eine übernormale Pause gar nicht besteht; die Herzruhe dauert nur so lange, als nöthig ist, um die vorhergehende Verkürzung der Pause zu compensiren. Wenn abnorm hohe Energiemengen sich angehäuft haben, so ist daran nicht die *Pause* Schuld, sondern die *abortive, künstlich herbeigeführte Systole*, die wegen ihrer Kleinheit nicht denjenigen Energievorrath erschöpft hat, der einer normalen Systole zu Verfügung gestanden hätte."

Since the extra contraction, however small, is, for the time when it occurs, maximal, it consumes all the available energy that has accumulated up to that time. The accumulation of energy after it begins at zero, and proceeds gradually. Whether the compensatory pause be called "übernormal" or not, it is longer than the regular pause, and so allows time for the accumulation of more than the regular quantity of energy. It would be difficult, following LANGENDORFF's view, to understand the weakness of the extra contraction.

It shows also the Bowditch "staircase" phenomenon.

It does not show, when beating spontaneously, a "compensatory pause" after an extra contraction. The extra contraction is followed by a somewhat *shortened* but variable pause, and the earlier in diastole the extra contraction has intervened, the shorter is the following pause.

The spontaneous beat following an extra contraction of the apex is much stronger than the regular beat. This results from the hastening of the extra contraction, being an example of the "staircase" effect.

The height of any contraction of the apex, or of the frog's heart, is, *ceteris paribus*, roughly proportional to the length of the preceding pause.

The hastened extra contraction has in the dog's apex an actual stimulating effect, which persists on the average for about eight subsequent beats. The more hastened the extra contraction, the stronger is its stimulating effect. Two or more extra contractions have a stronger stimulating effect than one.

The optimum interval between beats is much shorter in the dog's apex than in the frog's heart, being as small as one second.

The dog's apex is not thrown into complete tetanus, nor into incomplete tetanus with superposition of contractions, by the action of faradic or galvanic currents.

A preparation similar to that from the dog's apex, but including some of the base with ganglion cells, responds to electrical stimulation in the same way as the apex.

The frog's ventricle as well as the dog's apex is absolutely refractory during systole. Hildebrand's explanation of the apparent exceptions is shown to be correct.

During the compensatory pause of the frog's ventricle, both irritability and contractility are high; hence the pause is not a period of inhibition.

Kaiser's statement that two extra contractions of the frog's heart are followed by a longer pause than one, three than two, etc., is not confirmed. Two or more extra contractions are often followed by even less than the normal length of pause.

Engelmann's explanation of the compensatory pause is supported by some new facts and is undoubtedly correct.

The absence of the compensatory pause from a spontaneously beating piece of the dog's ventricle goes to prove that where the ventricle

does show a compensatory pause, as in the normal heart beat, there the ventricle is not spontaneous.

The great force of the beat following the extra contraction is dependent, in the frog's ventricle, mostly on the prolonged compensatory pause. It is not directly dependent, as Langendorff supposes, on the weakness of the extra contraction.

No special or active compensatory function has yet been demonstrated in the heart; such compensation as appears after an extra contraction is incidental to the action of well-known properties of the cardiac muscle.



THE RATE OF NERVOUS IMPULSE IN CERTAIN MOLLUSCS.

BY O. P. JENKINS AND A. J. CARLSON.

[From the *Physiological Laboratory of Leland Stanford Junior University.*]

IN 1863 Fick¹ estimated the rate of the nervous impulse in *Anodon* as not more than one centimetre per second. He used the graphic method and based his estimate upon a small number of experiments. In more recent years the rate in three species of cephalopods has been determined. Fuchs,² in 1894, found in the mantle nerve of *Eledone moschata* a rate of one metre per second. His determination was made by measuring the delay in the negative variation. Uexküll,³ also in 1894, found in the same species, by means of the graphic method, a rate of one-half to one metre per second. Boruttau,⁴ in 1897, determined by the method used by Fuchs, rates of three and one-half to five and one-half metres per second, in *Octopus vulgaris*, *Octopus macropus*, and *Eledone moschata*. So far as we have been able to learn, no other attempts have been made to determine the rate of the nervous impulse in molluscs. In this paper are presented the results obtained by us in determining the rate of the nervous impulse in the following species⁵ of molluscs: *Ariolimax columbianus* (var.), *Limax maximus*, *Pleurobranchæa californica*, *Octopus punctatus*, and *Loligo pealii*.

¹ FICK: Beiträge zur vergleichende Physiologie der irritablen Substanzen. Braunschweig, 1863.

² FUCHS: Sitzungsbericht der kaiserlichen Akademie der Wissenschaften. Wien, 1894, ciii, p. 207.

³ UEXKÜLL: Zeitschrift für Biologie, 1894, xxx, p. 317.

⁴ BORUTTAU: Archiv für die gesammte Physiologie, 1897, lxvi, p. 285.

⁵ The identifications of the species of *Ariolimax* and *Limax* were made for us by Mr. H. A. PILSBRY of the Academy of Natural Sciences of Philadelphia; those of *Octopus* and *Loligo*, by Professor H. HEATH of Stanford University. The sea rabbit is described in an unpublished paper by Professor F. M. MACFARLAND of Stanford University, as *Pleurobranchæa californica*.

Under the heading of each species are given the nerve experimented on, the dissection necessary, and the arrangement of apparatus used. A large number of graphic records were taken. A representative pair of tracings, one obtained by stimulation of the peripheral point, the other from the central, which show well the characters of the contractions, is given for each species. In *Ariolimax columbianus*, *Limax maximus*, and *Pleurobranchæa californica*, the time of contraction is of such a length that only the portions of the curves showing the latent periods are given. In *Octopus punctatus* the period of contraction is much shorter, and a large portion of its curve is given. In *Loligo pealii* the contraction and relaxation are prompt and quickly passed, producing a curve very similar to one obtained from a vertebrate muscle-nerve preparation. A single example of the tables of records obtained from each individual is also presented.

In this table, "the total latent period" represents the time from the instant of stimulation to the beginning of the contraction of the musculature. "The length of nerve" is the distance between the central and the peripheral points of stimulation. The "time of transmission" is the difference between the average of the latent periods obtained from the central point of stimulation and the average of those obtained from the peripheral point. The records from the central and the peripheral points were in most cases taken alternately. The summary given in the account of the experiments with each species brings together the rates obtained from the individuals of that species.

ARIOLIMAX COLUMBIANUS.

The giant slug, *Ariolimax columbianus*, first engaged our attention. This slug is abundant in the neighborhood of Stanford University. It is found in greatest numbers along the banks of San Francisquito Creek during the rains, but can be obtained in the more moist places along this stream even during the dry season. Individuals have been observed ten inches in length when extended in crawling. Consequently these animals furnish long pedal nerves, easily exposed, giving, in large individuals, from ten to twelve centimetres distance between the central and peripheral points of stimulation, which, together with the low rate of propagation, allows of fairly accurate determinations of rates. These conditions render the extent of the errors in measuring the rate of impulse in this nerve very much less than in the like determination in the nerves of ver-

tebrates where the rate is from seventy-five to one hundred times as great.

The following method was found to be the most serviceable: A large moist chamber with the usual furnishing of electrodes was constructed. The body of the slug, with the exception of two to three centimetres of the posterior portion, which was left free to contract and relax, was firmly pinned, foot down, to the movable wooden floor of the moist chamber. The movable floor could be clamped in any position and thus allowed a greater range of adjustment without disturbing the animal once fixed. It was also convenient for the removal of the abundant mucus secreted.

The animal was prepared by opening the body cavity by a longitudinal slit along the dorsal surface. The viscera being turned aside, the pedal ganglia and pedal nerves were exposed. The pedal nerves were sometimes cut close to the pedal ganglia, and sometimes were left in connection with the pedal ganglia, which were isolated from all other connections. All the branches of the pedal nerves were cut except those in the posterior portion of the foot. The tip of this free posterior end of the foot received a small hook, which was attached to a thread passing over a small light pulley to a horizontal writing lever below. The weighting of this lever to bring it into a horizontal position varied very much on account of the unequal relaxing of the preparation. The lever magnified the motion four times. During most of the work Zimmermann's universal stand was used to support this whole arrangement. This stand is almost essential in this work with this slug, since in it the unequal relaxations after contractions make necessary repeated adjustment of the apparatus to the recording drum to keep the writing point of the lever on the drum and in a perpendicular line with the signal and the time marker. For much of the work Ludwig's kymograph, Cambridge pattern, was used. However, Straub's electromotor drum was found to be by far the most convenient and serviceable, and after its adoption it was used in all subsequent work. Tuning forks of fifty or one hundred double vibrations, either applied directly or by means of an electric signal, gave the time. The means for an efficient stimulus was obtained from induction currents, the break being employed.

The Zimmermann vertical form of Du Bois-Reymond's induction apparatus was used, containing 10328 windings in the secondary coil. Four Edison-Lalande cells, type S, gave the primary current. With the signal placed in the circuit, as was always the case, this arrange-

ment gave a current of 0.6 ampere. Platinum electrodes were used for contact with the nerve, one pair for each point of stimulation, and so connected by means of a commutator that the same direction of current was used in each pair of electrodes.

The tendency of the slugs on being handled in any way, and much more on being injured, to contract the whole body and so remain for an indefinite time, introduces much difficulty in experimenting with them. The use of chloroform was found to be wholly impracticable, as it threw the animal into a strongly-contracted state in which it remained so long a time that further work was impossible. Ether proved to be serviceable, as it rendered the animal inactive, and put the body in a flaccid condition, allowing the preparation to be made successfully. This anæsthetic was used in many of the experiments. When used, only a sufficient amount was applied to complete the preparation, then a sufficient time was allowed to elapse to permit, as

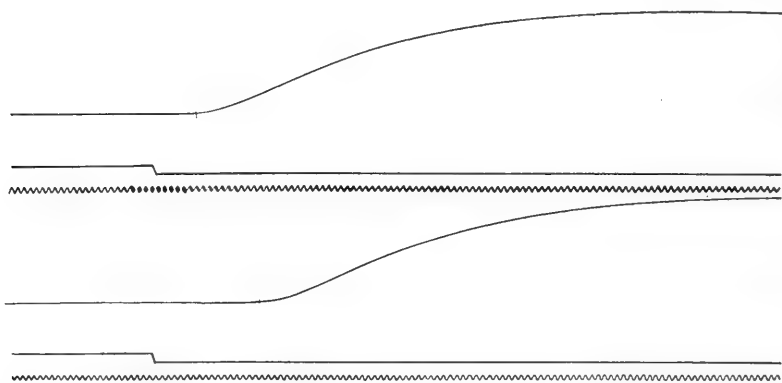

FIGURE 1.—Four-fifths the original size. *Ariolimax columbianus*. Pedal nerve. Distance between central and peripheral electrodes: 8 cm. Rate: 40 cm. per second. Time: 50 d. v. per second.

much as possible, a recovery from its effects before the experiment was begun. In the later experiments the anæsthetic was dispensed with, to avoid any possible errors which it might introduce, but no noticeable differences are found between results thus obtained and those obtained when the ether was used, followed by a delay for the effects to disappear.

The nerves remain sufficiently irritable for from twelve to twenty-four hours to obtain muscular responses, but, as the rate of the

nervous impulse seems to vary with the freshness of the preparation, only the first few tracings taken in each case are considered here. The rate seems also to vary with a large range of temperature, but as it is the purpose to consider conditions affecting the rate at another time, discussion of these conditions is deferred at present. Within the limits of temperature of the records here given, no variation in rate could be assigned to changes in temperature. The nerves were allowed, as much as possible, to lie in the blood and the abundant secretion of mucus, and were thus easily kept moist. The loss of moisture from the mucus was made up by the addition of distilled water to the mucus and blood, which, thus applied, seemed to act indifferently, while the usual physiological solutions acted as stimuli, and interfered with the experiments.

Altogether fifty-four slugs were used, from which two hundred and fourteen records were obtained, one hundred and nine of these being from central points of stimulation, and one hundred and nineteen from peripheral points.

Table I is given as an illustration of the data taken in a single individual. In Fig. 1 are given the curves obtained from another individual which are fairly representative.

TABLE I.

ARIOLIMAX COLUMBIANUS.

Detail of record of No. 45. August 22, 1901. Temperature, 17°-19° C.

Total latent period in seconds.	
Central.	Peripheral.
0.59	0.30
0.63	0.32
0.61	0.35
Average: 0.61	0.32
Transmission time: 0.29 sec. Length of nerve: 12 cm. Rate: 41.4 cm.	

Table II contains the rates obtained from the data of the fifty-four individuals.

TABLE II.

ARIOLIMAX COLUMBIANUS.

Summary of rates in fifty-four individuals.

No. of slug.	Rate in cm.	No. of slug.	Rate in cm.	No. of slug.	Rate in cm.	No. of slug.	Rate in cm.
1	48.14	15	68.64	29	37.5	43	22.00
2	35.5	16	55.5	30	36.52	44	40.85
3	46.4	17	76.5	31	73.75	45	41.4
4	56.00	18	29.15	32	59.00	46	31.5
5	39.68	19	65.78	33	43.12	47	21.21
6	51.46	20	54.00	34	58.13	48	66.4
7	54.4	21	21.66	35	57.26	49	68.75
8	30.15	22	21.1	36	28.91	50	25.3
9	43.31	23	32.11	37	22.00	51	26.1
10	36.92	24	36.67	38	20.00	52	52.2
11	31.85	25	37.96	39	94.64	53	48.00
12	30.24	26	28.85	40	48.3	54	21.65
13	56.12	27	24.44	41	87.00		
14	46.40	28	39.60	42	21.66		

As will be readily seen from this table, a great range, inside of limits, occurs in the rates obtained, and it is obviously impossible to fix upon any number as the rate of the nervous impulse in this slug. The conspicuous facts are the slowness of the rate and its variability, within the limits observed.

An application of methods in use in the study of varying data to these rates, gives the following results. In forming the classes the first of each pair is not included.

Class (rate in cm.)	15-25	25-35	35-45	45-55	55-65	65-75	75-85	85-95
Frequency	9	10	12	9	6	5	1	2

Of these the mean rate is 44 cm. per second.

The standard deviation is 18.

The coefficient of variability is 0.41.

LIMAX MAXIMUS.

This large slug, which is not a native of California, was obtained in abundance from the gardens in San José. The same apparatus was used in experiments with this slug that served with *Ariolimax*.

Limax maximus allowed a distance of from four to six centimetres of nerve between the central and peripheral points of stimulation. The nerves and muscles are more irritable, and die more quickly than those of *Ariolimax*, and the muscle gives a more prompt reaction. The animal secretes less mucus. Both pedal nerves were placed on the electrodes, and the induced break shock was used as the stimulus. No anæsthetics were used. On the whole, it was found much less difficult to obtain accurate records with this slug than with *Ariolimax columbianus*.

TABLE III.

LIMAX MAXIMUS.

Detail of record of No. 12. November 29, 1901. Temperature, 15° C.

Total latent period in seconds.		Total latent period in seconds.	
Central.	Peripheral.	Central.	Peripheral.
0.115	0.100	0.130	0.098
0.155	0.108	0.140	0.100
0.140	0.100	0.099
0.140	0.098	0.098
0.150	0.098		

Average central: 0.138. Average peripheral: 0.099. Transmission time: 0.039 sec. Length of nerve: 5.5 cm. Rate: 140.8 cm. per sec.

Twenty individuals were used. Table III is given as a representative of the records obtained, and Fig. 2 shows muscle curves which are typical of the series. In Table IV are presented the rates as calculated from the data obtained from the twenty slugs. They represent one hundred and seventy-five records, eighty-two from the central point of stimulation, and ninety-three from the peripheral point. The range of temperature was from 15° to 17° C. An

inspection of this table shows that in *Limax maximus* as in *Ariolimax columbianus*, there is a large coefficient of variability in the rate, the mean rate, however, being nearly three times as high.

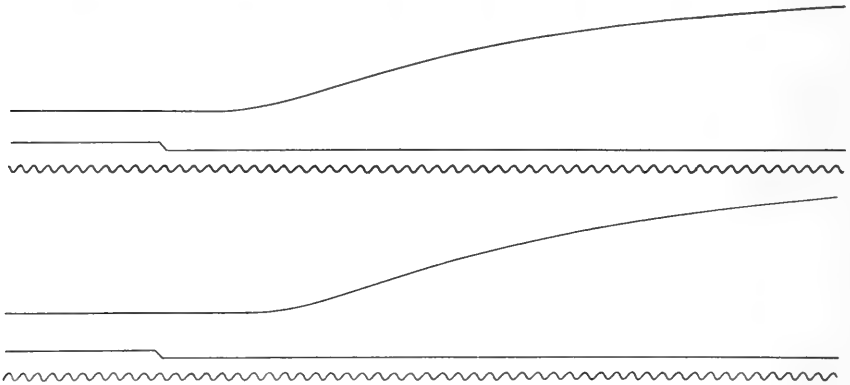

FIGURE 2.— Full size. *Limax maximus*. Pedal nerve. Distance between central and peripheral electrodes: 6 cm. Rate: 150 cm. per second. Time: 50 d. v. per second.

TABLE IV.

LIMAX MAXIMUS.

Summary of rates of nineteen individuals. Temperature of room from 15° to 18° C.

No. of slug.	Rate in cm.	No. of slug.	Rate in cm.	No. of slug.	Rate in cm.	No. of slug.	Rate in cm.	No. of slug.	Rate in cm.
1	54.0	5	204.0	9	157.8	13	91.3	17	124.8
2	75.0	6	90.0	10	102.0	14	94.0	18	136.2
3	222.0	7	83.0	11	206.4	15	120.0	19	48.6
4	166.5	8	103.2	12	140.8	16	131.5		

Analysis of the above table.

Class (rate in cm.)	30-70	70-110	110-150	150-190	190-230
Frequency	2	7	5	2	3

Mean rate, 124 cm. per second.

Standard deviation, 49.

Coefficient of variability, 0.39.

PLEUROBRANCHÆA CALIFORNICA.

The large sea rabbit of Monterey Bay served next in this series, and rates were determined from both pedal and mantle nerves. This species can hardly be said to be abundant at this point, since by the help of the local fishermen only occasional specimens were secured. Those obtained were brought in under our direction, and appeared to be uninjured and in normal condition. With but one exception experimentation was begun on each within a few hours after capture. In the one exception, the animal remained in the aquarium twenty-four hours before work was begun on it. This animal furnishes an excellent muscle-nerve preparation.

In the aquarium the animal was made to crawl upon a board of suitable size, which was clamped to the floor of the moist chamber in the manner made use of in the work with *Limax* and *Ariolimax*. When approximately normally extended, two strong needles were quickly thrust through the mantle and foot into the board on either side, about five or six centimetres from the posterior end of the foot. This caused the animal to contract strongly, but it soon relaxed, and was then similarly secured anteriorly. It was then removed from the aquarium, and prepared for experimentation in much the same way as were the slugs.

The pedal nerves run free in the body cavity for some centimetres from the ganglia, and then penetrate more or less deeply the musculature of the foot, then reappear on or near the surface two to three centimetres from the posterior end of the body cavity. The whole length of nerve between the central and the peripheral electrodes was dissected free in only two preparations. This amount of dissection was found to be unnecessary, and in the remaining animals the dissection was reduced to the severing of the side branches of the main nerves where the latter reappear in the posterior part of the body cavity. By this means the possible injury to the nerves by handling in dissecting was avoided. This did not affect the accuracy of the records, for the posterior reacting end was so secured that contractions in any other part of the foot did not interfere with its record. At the conclusion of each of the experiments, the nerves were dissected out and measured. In the experiments with the mantle nerve, the portion lying free in the body cavity was used, which consequently was not further disturbed by dissection. The writing lever was attached in the usual way to the mantle.

Throughout the experiment, the preparation was freely bathed with the fluid of the body cavity. With the same batteries and coils used with the slugs, strong contractions were obtained from the central point of stimulation with the secondary coil at fourteen centimetres from the primary. The irritability of the preparation decreases rapidly in the course of experimentation, and when but feeble contractions followed single break shocks with the secondary at 5 cm. to 0 cm. away from the secondary, strong contractions could be obtained with the interrupted current of from 0.02 sec. to 0.12 sec. duration with the secondary at from ten to twelve centimetres from the primary coil.

The preparation gave good reactions for from ten to twenty hours, if the stimulations were not too frequent. In one case the muscle gave feeble response to stimulations of the nerve twenty-six hours after the preparation was made.

TABLE V.

PLEUROBRANCHLEA CALIFORNICA.

Detail of record of No. 10, pedal nerve. January 10, 1902. Temperature of Aquarium, 14° C.

Central.	Peripheral.	Central.	Peripheral.
0.320	0.157	0.330	0.145
0.332	0.165	0.327	0.162
0.332	0.163	0.332	0.170
0.345	0.180	0.335	
Average central: 0.330. Average peripheral: 0.163. Transmission time: 167 sec. Length of nerve: 13 cm. Rate: 76 cm. per sec.			

After a large number of records were taken, the preparation usually seemed to show a marked decrease in the rate. For this reason, only the first few reactions were used in determining the rate. The two examples of the mantle nerves appear to indicate a lower rate than that of the pedal nerves, but a greater number of observations might have shown no difference in the mean rates, or the lower rate may be due to the fact that the records were obtained after the considerable delay caused by the use of the preparation in the experiments on the pedal nerves.

Table V exhibits the full records of a single individual. Fig. 3 contains typical tracings from one of the specimens. Table VI includes the rates from the pedal nerves of ten individuals. The rates from the mantle nerves of two specimens are appended. In this mollusc it will be noted that while the rate is low, there is in the series used a comparatively small coefficient of variation in the rates.

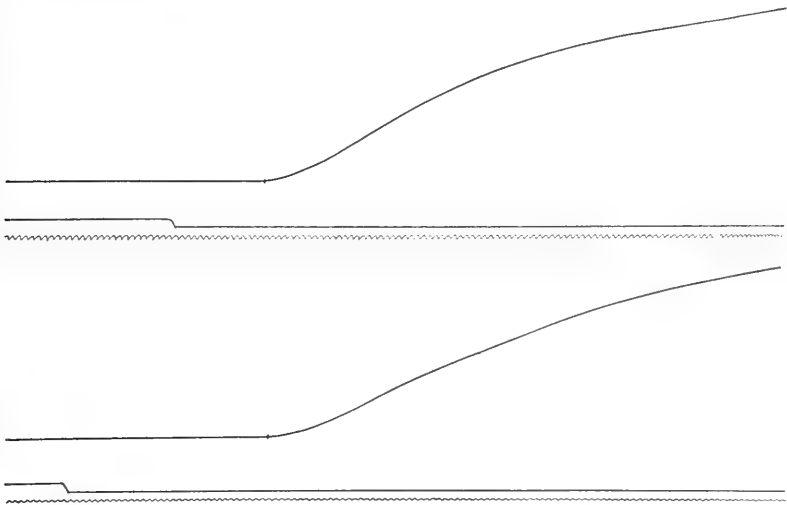

FIGURE 3.—About four-fifths the original size. *Pleurobranchæa californica*. Pedal nerve. Distance between central and peripheral electrodes: 13 cm. Rate: 71.5 cm. per second. Time: 100 d. v. per second.

TABLE VI.

PLEUROBRANCHÆA CALIFORNICA.

Summary of rates in the pedal nerves in ten individuals. Temperature of aquarium, 12° to 15° C.

No. of specimen.	Rate in cm.	No. of specimen.	Rate in cm.
1	69.4	6	61.6
2	84.6	7	77.0
3	65.2	8	93.75
4	85.0	9	90.9
5	80.9	10	76.0

Analysis of Table VI:

Class (rate in cm.)	55-65	65-75	75-85	85-95
Frequency	1	2	5	2

Mean rate, 78 cm. per second.

Standard deviation, 7.8.

Coefficient of variation, .10

The rates obtained from the mantle nerves of two individuals were sixty-one centimetres and fifty-four centimetres per second respectively.

OCTOPUS PUNCTATUS.

This species of Octopus is fairly common at Pacific Grove. We obtained records from eight individuals. Seven were studied December, 1901, to January, 1902, and one in the summer of 1902.

The same muscle-nerve preparation was used that Uexküll employed in his experiments on Eledone. The nerve portion consisted of the pallial nerves, and the muscular portion of a wide strip of the mantle muscle around the stellate ganglion, from three to four centimetres long and two centimetres wide. The muscle strip was made to pull either vertically or horizontally, the two methods giving the same results. No anæsthetics were used. The nerve was not entirely freed from the adjacent muscular tissue, as it was found difficult to free it without injury. The preparation was kept moist by sea-water.

With the same electrical arrangement used in the preceding experiments, contractions were obtained with the secondary at from twenty-two to eighteen centimetres from the primary. The break was employed throughout, and from two to three minutes were allowed to elapse between the stimulations. The peripheral electrodes were placed two to four millimetres from the ganglion. That there was no direct stimulation of the muscle by the escape of the current from the peripheral electrodes, seems to be proved by the fact that it required ten to fifteen times the intensity of stimulus used with the nerves to secure equal contractions when applied directly to the muscle. Furthermore, the low degree of the intensity of stimulus made improbable the escape of the current from the peripheral point to the ganglion, thus directly stimulating it.

Table VII, giving the detail of the records, of one specimen, shows great uniformity in the records, although a great number of tracings

TABLE VII.

OCTOPUS PUNCTATUS.

Detail of record of No. S. January 2, 1902. 14° C. Total latent period in seconds.

Central.	Peripheral.	Central.	Peripheral.
0.066	0.050	0.070	0.048
0.067	0.045	0.069	0.050
0.066	0.045	0.075	0.054
0.068	0.046	0.070	0.050
0.068	0.046	0.054
0.070	0.046	0.070	0.051
0.065	0.047	0.070	0.048
0.070	0.053	0.070	0.049
0.075	0.055	0.075	0.055
0.072	0.070	0.053
0.070	0.050	0.075	0.053

Average central : 0.070. Average peripheral : 0.050. Transmission time : 0.02 sec. Length of nerve : 4 cm. Rate : 200 cm. per sec.

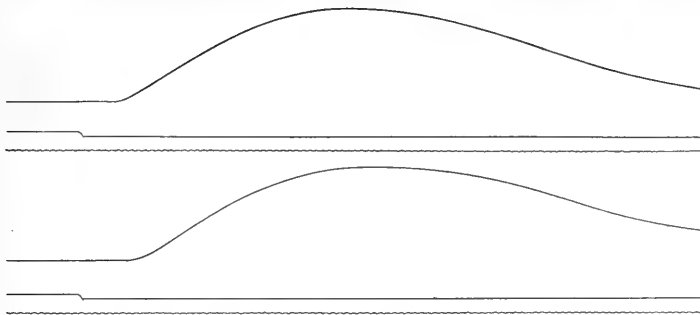

FIGURE 4.— One-half the original size. Octopus punctatus. Pallial nerve. Distance between central and peripheral electrodes : 4 cm. Rate : 200 cm. per second. Time : 100 d. v. per second.

were taken from the single individual. Fig. 4, exhibiting a pair of tracings, shows a nearer approach in form to the muscle curve of the vertebrates. Table VIII brings together the records of eight unin-

jured individuals. It will be noted that the rate is comparatively higher than in the preceding molluscs, and that there is also a comparatively small coefficient of variability.

TABLE VIII.

OCTOPUS PUNCTATUS.

Summary of rates in eight individuals. Temperature of aquarium, 12° to 14° C.

No. of specimen.	Rate in cm.	No. of specimen.	Rate in cm.
1	227	5	230
2	192	6	202
3	192	7	200
4	227	8	158

Analysis of table.

Class (rate in cm.)	140-170	170-200	200-230
Frequency	1	2	5

Mean rate, 200 cm. per second.

Standard deviation, 20.

Coefficient of variability, 0.10.

LOLIGO PEALII.

This species is found in abundance in Monterey Bay during the breeding season (June-July). We succeeded in keeping the specimens in good condition in the aquarium for from one to three days only, as they soon injured themselves by darting against the sides of the aquarium.

The pallial nerve left in connection with the fin served as the muscle-nerve preparation. Each nerve issues through the cranial cartilage in two branches closely joined to one another. One branch enters the stellate ganglion; the other courses past it, runs free in the body cavity near the median line, and penetrates the mantle about two centimetres dorsally to the ganglion, taking a dorso-lateral direction, and issues on the dorsal side of the mantle at the anterior edge of the fin, where it immediately radiates into the musculature of the latter.

The animal was secured to the floor of the moist chamber, dorso-

lateral surface down, part of the mantle being removed in order to facilitate the freeing of the pallial nerve on one side. The two branches were severed near the cranial cartilage, and the branch to the stellate ganglion cut near the latter, as it was found difficult to separate the two without injury. The integument was removed from the anterior part of the fin and adjacent parts of the mantle, and the issuing branches of the nerve separated as completely as possible from the muscle for from five to eight millimetres. This served as the point of application for the peripheral electrodes. The hook, connected by a thread to the writing lever, was fastened to the fin at about its middle portion. The preparation being turned slightly to one side, the fin was bent dorsally, the outer edge touching the platform. The beginning of movement ventralward was communicated to the lever. The latter had to be very delicately adjusted because the power of the fin in this position is slight.

TABLE IX.

LOLIGO PEALII.

Detail of record of No. 33. Temperature, 13° C.

Total latent period in seconds.		Total latent period in seconds.	
Central.	Peripheral.	Central.	Peripheral.
0.043	0.027	0.043	0.028
0.043	0.027	0.044	0.027
0.040	0.025	0.044	0.028
0.042	0.028	0.045	0.027
Average central : 0.043. Average peripheral : 0.027. Transmission time : 0.016 sec. Length of nerve : 8 cm. Rate : 500 cm. per sec.			

With the device for stimulating the same as in Octopus, maximal contractions were obtained with the secondary coil at twenty-six to twenty-one centimetres from the primary.

The nerve dies within five to ten minutes after being prepared. Hence only one preparation from each animal could be used. No anæsthetics were employed.

In the summary are brought together the results obtained from

the records of thirty-four individuals, twenty-two of which were taken in the summer of 1901, and twelve obtained in the summer of 1902.

Table IX, the detail of the records of a single individual, shows great uniformity throughout the experiment. Fig. 5 shows the tracings from one of the animals. They are fairly typical of the series. The form is notably similar to the muscle curve obtained from the gastrocnemius of the frog.

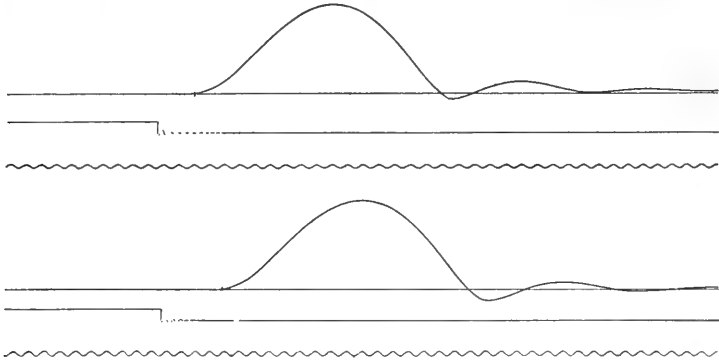

FIGURE 5.—Full size. *Loligo pealii*. Nerve to fin. Distance between central and peripheral electrodes: 8 cm. Rate: 444 cm. per second. Time: 100 d. v. per second.

TABLE X.

LOLIGO PEALII.

Summary of rates in thirty-four individuals. Temperature of Aquarium, 12° to 14° C.

No. of specimen.	Rate in cm.	No. of specimen.	Rate in cm.	No. of specimen.	Rate in cm.	No. of specimen.	Rate in cm.
1	499.9	10	350.0	19	325.0	28	400.0
2	499.8	11	350.0	20	325.0	29	335.5
3	650.0	12	333.0	21	337.1	30	800.0
4	650.0	13	312.6	22	365.7	31	700.0
5	499.8	14	366.3	23	472.0	32	404.0
6	458.1	15	325.0	24	561.2	33	500.0
7	406.2	16	341.9	25	353.6	34	420.8
8	392.7	17	350.0	26	400.0		
9	323.4	18	338.3	27	472.0		

Analysis of above table.

Class (rate in cm.)	250-350	350-450	450-550	550-650	650-750	750-850
Frequency	10	10	9	3	1	1

Mean rate, 435 cm. per sec.
 Standard deviation, 121.
 Coefficient of variability, 0.28.

In Table X, are the results obtained from thirty-four individuals. An examination of the table shows a much higher rate than shown in the other molluscs experimented with. The range is also large. With the two, Nos. 30 and 31, which have the exceptionally high rates of seven hundred centimetres and eight hundred centimetres per second, there were no special conditions which we were able to observe which could account for these specially wide variations.

For convenience of comparison, the results of the determination of the rates in these molluscs are brought together in Table XI:

TABLE XI.

Species.	No. of individuals.	Nerve.	Mean rate in cm.	Standard deviation.	Coefficient variability.
<i>Ariolimax columbianus</i>	54	pedal	44	18.0	0.41
<i>Limax maximus</i>	19	pedal	124	49.0	0.39
<i>Pleurobranchæa californica</i>	10	pedal	78	7.8	0.10
<i>Pleurobranchæa californica</i>	2	mantle	58
<i>Octopus punctatus</i>	8	pallial	200	20.0	0.10
<i>Loligo pealii</i>	34	to fin	435	95.0	0.28

The muscle curves of these molluscs, compared with their rates of nervous impulse, show a corresponding progressive series. The lower rate is accompanied by a slow and long continued contraction of the muscle, the recovery from the contraction being also much prolonged.

With the increase of rapidity of nervous conduction is a corresponding increase in the promptness and quickness of muscular contraction and in its rapid recovery. A series could be selected from these molluscs which would show a marked progressive development in nerve and muscle, of those conditions and properties which make

possible the prompt and accurate motions which are the marked characteristics of highly organized animals.

A series based upon the rates of nervous impulse, and the compactness of the myogram in these animals, coincides with one based on the degree of activity shown by them in their means of locomotion.

The slowest in motion is *Ariolimax*, and far surpassing it is *Octopus*, which in turn is well outstripped by *Loligo*. The rates of nervous impulse, and the forms of the myograms of the three, well express the differences in the degree of activity manifested by the three. It would seem that these molluscs offer a promising field for the investigation of certain problems in nerve and muscle physiology from the very fact of these gradations in the properties of the nerve and muscle tissue in them.

ON THE INFLUENCE OF CALCIUM AND POTASSIUM SALTS UPON THE TONE OF PLAIN MUSCLE.

By PERCY G. STILES.

[From the *Physiological Laboratory of the Massachusetts Institute of Technology.*]

IT is a familiar fact that minute additions of a calcium salt to a circulating medium lead to an increased tone of the cardiac muscle, and that a potassium salt may be employed to antagonize this action. This antagonism, first pointed out by Ringer, and since investigated by Howell and many others, has come to be a matter of ready demonstration in every laboratory. But it has also been noticed that the influence of calcium and potassium upon the tone of the heart is not the same, even qualitatively, when concentrations much greater than the physiological ones of the blood are used.

In studying the influence of salts upon the rhythmic property of the œsophagus, the writer found that for quantities of potassium and calcium near the amount normal in the blood, the effect of each is definite, and the antagonism distinct; calcium causes shortening of the fibres, potassium relaxation. But it became evident at that time that the same rule does not apply to plain muscle, any more than to the heart, when quantities of calcium and potassium in excess of the physiological are used. An investigation of the specific effects of calcium and potassium in higher concentrations seemed desirable, and the more so because contradictory statements are common in the recent literature of such subjects.¹

Experiments of a simple character were made upon the following plan. A strip from the stomach of the frog was immersed in a bath, and made to record its changes of extension by means of a light lever. The tone under observation was that of the circular musculature.

¹ For example, ZOETHOUT (This journal, 1902, vii, p. 199) finds that potassium salts throw skeletal muscles into strong tonic contraction, and that calcium salts do not produce such a degree of tone. He made use of pure solutions of these salts, isotonic with the blood. These results are in harmony with my own *for high concentrations.*

The bath, contained in a small beaker, consisted of exactly 25 c.c. of 0.7 per cent sodium chloride solution, to which accurately measured additions of 1 per cent calcium chloride and 1 per cent potassium chloride were made from time to time. The composition of the mixture at any moment could be calculated. The strength of the solutions was such that the osmotic pressure could not have been significantly changed by adding them to the bath. Spontaneous contractions were often observed, as was anticipated, but no attention was paid to them. Observation was limited to the changing base-level upon which these contractions were superimposed.

In eighteen experiments which it is needless to detail, the effects of various concentrations of calcium chloride and potassium chloride, both separately and combined, were noted.

The physiological amounts of calcium and potassium salts are imitated in the Ringer's solutions in common use. These contain not far from 0.026 per cent calcium chloride, and 0.03 per cent potassium chloride, — the proportions recommended by Howell and Greene, and based upon analyses of the ash of terrapin blood. In such proportions the two salts exhibit clearly the specific influences usually attributed to them. A solution of sodium chloride, plus 0.026 per cent calcium chloride, raises the tone of a smooth muscle preparation; a solution of sodium chloride, plus 0.03 per cent potassium chloride, depresses it. Now, what are the facts when we exceed the physiological limits in the concentration of either salt?

The effect of sodium chloride upon tone is a factor which ought to be reckoned with. Plain muscle placed in sodium chloride solution relaxes steadily for a long time, and probably reaches at last as great an extension as can be induced by any mixture of salts. So the effect of potassium chloride in the same direction can only be inferred from its power to *hasten* the decline of tone, or, better, from what is seen when enough calcium chloride is present to neutralize the depressing effect of the sodium chloride.

Making allowance for a depressing property of sodium chloride which was exerted at the beginning of each experiment, the following facts were deduced. Calcium chloride causes increase of tone, whether it is brought to the contractile tissue in small amounts, or in concentrations as great as 0.3 per cent, — perhaps twelve times the physiological concentration. Up to this strength of solution at least, the rise of tone proceeds regularly and hand in hand with the increasing calcium content of the bath.

With potassium chloride the case is less simple. The depressing effect of this salt upon tone was readily confirmed for concentrations below 0.15 per cent. When this percentage is exceeded, the effect is obscure at first; but when the concentration passes above 0.2 per cent, the tone is clearly heightened by the potassium chloride, just as it is by calcium chloride. With concentrations of 0.3 per cent or 0.4 per cent potassium chloride, the tone is intense. Thus it appears that calcium and potassium have an antagonistic action when each is present in a low concentration, but each acts to cause tonic contraction when a somewhat larger amount is present.

The experiments in which both calcium chloride and potassium chloride were used at once in varying quantity show that the combined effect is just what would be anticipated from the facts stated above. The most marked depressing effect secured with potassium chloride is with a concentration of about 0.1 per cent. Such an

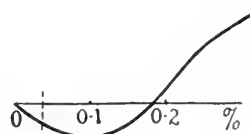
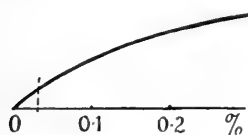

Effect of calcium chloride in increasing concentration upon the tone of smooth muscle.

Effect of potassium chloride in increasing concentration upon the tone of smooth muscle.

The dotted verticals indicate the effects of physiological percentages of each salt.

amount of potassium chloride was found to keep the tone at a low level until calcium chloride to nearly twice that percentage had been introduced. Then a rise of tone would set in, and further additions of potassium chloride would not check but rather promote it. The action of the two salts when simultaneously present is, therefore, to be represented, roughly at least, by the algebraic sum of their effects when tried separately.

The facts can be graphically presented, but with the caution that these curves are merely of qualitative meaning; there is no unit of measurement for the tone-changes, nor are the ordinates of one curve exactly comparable with those of its fellow.

There is one objection to my method of experiment which has a certain force and must be admitted. When calcium chloride or potassium chloride solutions are added to a bath which originally contained 0.7 per cent sodium chloride, the percentage of sodium

chloride is diminished by dilution, and it is natural to ask whether the rise of tone which was ultimately brought about, whether calcium chloride or potassium chloride was added, might not be due to lack of sodium rather than to the other salts. As a matter of fact, the sodium chloride was never reduced below 0.45 per cent in experiments the results of which were considered seriously. This tissue does not go into tone when placed in a hypotonic sodium chloride solution of 0.45 per cent, nor does it when 0.7 sodium chloride is diluted to the same extent with isotonic dextrose solution. So it seems probable that the effects on tone were really due to the calcium and potassium salts.

These observations do not justify the writer in entering into the current controversy regarding the precise rôle of sodium, calcium, and potassium ions in life-processes. But it may be timely to emphasize the importance of studying the action of these elements *in physiological percentages*. How unsafe it is to infer anything as to the normal influence of a salt from its effect at an abnormal concentration is well shown in the case of potassium chloride which, when present in an amount of 0.2 per cent or more, has quite the contrary action to that which is properly regarded as its physiological one.

My acknowledgments are due to Dr. Theodore Hough, by whose courtesy the laboratory was opened to me.

ON DIFFERENCES IN THE DIRECTION OF THE ELECTRICAL CONVECTION OF CERTAIN FREE CELLS AND NUCLEI.

BY RALPH S. LILLIE.

[From the *Physiological Laboratory of the Harvard Medical School.*]

I. INTRODUCTORY.

IT has long been known that minute particles of various substances suspended in distilled water or other feebly conducting media in which are immersed the terminals of a battery, are set in motion and travel through the liquid toward one or the other of the two poles, the direction of migration depending partly on the chemical composition of the suspended particles, and partly on the nature of the medium; thus particles of silica, graphite, and sulphur travel in water toward the anode, but in turpentine the direction of migration is reversed in the case of the first two substances. A difference of electrical potential between particle and medium is thus indicated; the suspended particles are charged oppositely to the medium at the surface of contact between the two; they therefore move up or down the potential gradient according to the sign of the charge they carry, whether negative or positive respectively.¹

Recently this conception has received an interesting special application in the case of colloidal solutions. Colloidal substances in solution have been shown to exhibit a tendency to collect in the neighborhood of the electrodes when a current is passed;² such solutions have furthermore been proved very clearly to consist of suspensions of discrete particles, typically in a very fine or even ultra-microscopical state of subdivision. The conclusion seems there-

¹ For an account of the phenomena of electrical endosmose and electrical convection, see WIEDEMANN: *Elektricität*, second edition, 1893, i, pp. 993-1023.

² See PICTON and LINDER: *Journal of the Chemical Society*, 1892, lxii, p. 148, and 1897, lxxi, p. 568; COEHN: *Zeitschrift für Elektrochemie*, 1897, iv, p. 63; HARDY: *Journal of physiology*, 1899, xxiv, p. 288.

fore inevitable that each colloidal particle carries an electrical surface-charge; in some cases this is positive, in others negative, as indicated by the characteristic differences in the direction of migration of different colloids.¹ A partial insight is thus gained into the nature of certain of the most typical peculiarities of hydrosols, — in particular their remarkable susceptibility to the coagulative action of electrolytes and their indifference toward non-electrolytes. It is further found that different salts vary in their ability to effect precipitation of a given colloidal substance; in several instances it has been determined that precipitation is due chiefly to the action of ions bearing charges of opposite sign to those of the colloidal particles; the coagulative power of an ion is found also to be to a marked degree a function of the number of its charges, increasing very rapidly with increase in valency.² All of these peculiarities have been found susceptible of more or less satisfactory explanation on the basis of the above theory.³

The researches of PICTON and LINDER⁴ and HARDY⁵ indicate furthermore that the sign of the charge carried by the particles in a hydrosol bears a definite relation to the chemical nature of the colloidal substance, acid particles being electrically negative and basic particles positive. Thus the particles are positively charged in hydrosols of ferric hydrate, aluminium hydroxide, methyl violet, Magdala red, alkali-albumin in acid solution; they are negatively charged in hydrosols of silica, arsenious sulphide, aniline blue, and alkali-albumin in alkaline solution. It seems probable that this relation, if of general validity, is of far-reaching physiological significance. Thus it is known that a large series of proteids, the nucleo-proteids, possess pronounced acid characteristics; also that the degree of acidity of these compounds varies with the proportion of nucleic acid present,⁶

¹ See PICTON and LINDER: *Loc. cit.*; also — for an excellent discussion and résumé of the chief literature bearing on the nature of colloidal solutions — BREDIG: *Anorganische Fermente*, Leipzig, 1901. A résumé and literature list are also given by WHITNEY and OBER: *Journal of the American Chemical Society*, 1900, xxii, p. 842.

² See especially HARDY: *Proceedings of the Royal Society*, 1900, lxvi, p. 110; also PICTON and LINDER: *Journal of the Chemical Society*, 1895, lxvii, p. 63.

³ For an ingenious instance, see WHETHAM, quoted in HARDY's paper in *Journal of physiology*, 1899, xxiv, p. 288.

⁴ PICTON and LINDER: *Journal of the Chemical Society*, 1897, lxxi, p. 568.

⁵ HARDY: *Journal of physiology*, 1899, xxiv, p. 288.

⁶ See LILIENFELD: *Archiv für Physiologie*, 1893, p. 391.

reaching a maximum in the chromatin of dividing cells and spermatozoa where the proportion of nucleic acid is highest. The chromatin of sperm-heads appears indeed frequently to consist chiefly of nucleic acid in proteid-free combination with various organic bases (protamin, sturin, arbacin¹); many chromosomes are probably of similar composition; to this corresponds the intense affinity of these structures for basic or nuclear dyes. On the other hand, the extra-nuclear or cytoplasmic proteids seem predominantly basic in character, evincing a special affinity for *acid* dyes. A contrast thus exists between the nuclear and the cytoplasmic colloids in respect to general chemical character. It follows — if the above defined relation holds true in this instance — that a corresponding electrical difference must accompany this chemical difference; in other words, that the chromatin colloidal particles are negatively, the cytoplasmic positively charged. On this theory a permanent though variable difference of electrical potential must exist between chromatin and cytoplasm in the living cell.

This condition, if actual, must of necessity profoundly influence the mutual relations of nucleus and cytoplasm. Thus, if the measure of this electrical difference is indicated by the degree of contrast in the reactions of chromatin and cytoplasm toward the usual dyes, it is evident that the above difference of potential must be greatest at the period of mitosis, since it is then that the chromatin is invariably in its most strongly acid and (on the above theory) electrically negative phase. The further consideration immediately presents itself that it may be this potential-difference which in itself constitutes the primary and determining condition of mitosis. *In all cases* the appearance of the cytoplasmic radiations and the formation of the mitotic figure are accompanied by a passage of the nuclear chromatin into a phase rich in nucleic acid; evidently the two parallel series of changes are intimately inter-connected. The marked resemblance between the rays of the mitotic figure and the electrical and magnetic lines of force — not to mention other typical peculiarities of mitosis — affords no little additional indication that the process is essentially electrical in its nature. Certainly, in view of our present knowledge of the physical chemistry of colloidal solutions — even though this is as yet far from complete — we must admit that electrical theories of mitosis are

¹ See MIESCHER: *Gesammelte Abhandlungen*, Leipzig, 1897, p. 55; KOSSEL: *Zeitschrift für physiologische Chemie*, 1896, xxii, p. 179; MATHEWS: *Ibid.*, 1897, xxiii, p. 339.

entitled to more careful consideration than they have hitherto received. I shall not, however, discuss these questions at length in the present paper; the above remarks are intended merely to indicate the nature of the considerations that have led to the performance of the following experiments.

It may be assumed that the direction and speed of the electrical migration of living cells and portions of tissues are chiefly dependent upon the electrical characteristics of their constituent colloids. Free nuclei, and especially nuclei whose chromatin contains a high proportion of nucleic acid, should on this assumption migrate with the negative stream, while cells with voluminous cytoplasm should prove less strongly negative, or even in some cases exhibit a positive direction of migration. The following experiments represent the beginning of a series designed to test these and other inferences from the hypothesis outlined above.

II. EXPERIMENTAL.

The methods were as follows: Finely divided tissues, in as fresh a condition as possible, were teased in $\frac{2}{4}$ cane-sugar solution (isotonic with physiological salt-solution) and mounted in the same medium upon a specially prepared slide, so constructed that the entire preparation while under examination could at any time be exposed to the action of the electric current. The construction of this slide is as follows: a long cover-glass (50 by 25 mm.), around which pass two tightly drawn transverse loops of thin platinum wire about 15 mm. apart, is cemented by means of Canada balsam to an ordinary microscopical slide. The platinum wires are connected through a pole-changer and simple key to the poles of a battery; this has consisted usually of three storage cells with an aggregate E. M. F. of from 7 to 7.5 volts. The tissues and cells under examination are mounted in sugar-solution on the slide in the space between the wires, and their behavior in the electric field can then be studied under high powers. The rate of movement is measured by means of the ocular micrometer. The resistance of the sugar-solution is very high and only a slight current passes between the platinum wires; as a rule, however, a few minute gas bubbles appear on the wires after the current has been flowing for a few minutes. It has not been thought necessary to measure each time the exact strength of this feeble current, which would obviously be found to exhibit considerable variability, since

the diffusion of electrolytes from the tissues under examination into the medium must necessarily confer upon the latter a certain slight and variable degree of conductivity.

The following structures have been examined by the above methods; isolated nuclei containing chromatin in different states of aggregation (nuclei of spermatozoa, small leucocytes, nuclei from lymphoid tissues); also cells and tissues with relatively voluminous cytoplasm, such as muscle-cells, red blood-corpuscles, and the larger forms of leucocytes.

When the corpuscles of freshly drawn frog's blood are examined under the conditions described above, characteristic differences in the behavior of the different elements become at once apparent. The majority of the red corpuscles move slowly (at an average speed of approximately 120 to 130 μ per minute) in the direction of the negative stream; but a considerable number exhibit no decided movement in either direction, and a few are weakly positive. The leucocytes vary in behavior,¹ the minute lymphocytes (ca. 10 μ in diameter) almost always exhibit a well-marked negativity, moving rapidly (at an average of speed of approximately 1,500 μ per minute) toward the anode. Leucocytes of medium size (15 to 20 μ) are usually slightly negative, but may be indifferent or even slightly positive; while the more voluminous leucocytes (25 to 30 μ diameter) are in almost all instances decidedly *positive*, moving definitely toward the cathode, although at a moderate speed (120 to 130 μ per minute). The same differences of behavior appear if the cells are obtained by fine subdivision of the spleen or thymus, voluminous leucocytes (25 μ and upward) being almost invariably positive, while the smallest leucocytes, which consist essentially of nuclei with merely a thin surface-film of cytoplasm, are strongly negative.

The appearance of the microscopic field during the passage of the current is remarkable: although all the cells in the field are under identical external conditions, some are seen to travel in one direction, while others simultaneously pursue a diametrically opposite course. Whenever the direction of the current is changed, each cell

¹ E. DINEUR (Bulletin de la Société belge de Microscopie, 1891-2, xxviii, No. 5, p. 113) placed electrodes consisting of platinum wires enclosed in capillary tubes within the peritoneal cavity of the frog, and found that the leucocytes tended to enter these tubes, especially the one connected with the positive pole of the battery. Under certain conditions (as in inflammation) they tended rather to enter the negative electrode. He attributed the movements to a special sensibility to electricity ("galvanotaxisme") possessed by the leucocytes.

instantly reverses the direction of its movement and proceeds with its original velocity in exactly the reverse direction. We have, as it were, a graphic representation of the migration of ions in an electrolyte-solution through which a current is passing, the lymphocytes or free nuclei corresponding to anions, and the large leucocytes to kations. The rate of migration of these cells, needless to say, greatly exceeds that of the ions since the frictional resistance at the surface of contact with the medium is relatively slight for such large bodies; in other respects the parallel appears remarkably close. For instance, if the current is allowed to flow for a considerable period in one direction, there results a gathering of red corpuscles and smaller leucocytes at the anode, and of the voluminous leucocytes at the cathode. This difference in the direction of electrical convection presumably implies a corresponding difference in the sign of the aggregate electrical charge carried individually by cells of the above two kinds.

From the thymus numerous small and densely staining nuclei may be obtained by teasing. Many of these are of almost uniform size (approximately $10\ \mu$ in diameter); they are always found to exhibit a very uniform and rapid movement (from 1.5 to 2.0 mm. per minute) in the direction of the negative stream. These nuclei show the most rapid movement of any hitherto observed, with the exception of the heads of spermatozoa. Treatment with methyl green demonstrates that they possess an unusually dense and deeply staining chromatin.

Fine subdivision of the testis of winter-frogs under sugar-solution yields a milky fluid containing large numbers of isolated spermatozoa, together with an organic debris consisting chiefly of partially destroyed cells and cell-aggregates. The vibratile movements of the spermatozoa are arrested by the sugar-solution, the substance of the tails apparently undergoing liquefaction, so that under examination with high powers the spermatozoa appear finally to consist essentially of isolated sperm-heads. Undoubtedly, however, a thin film of cytoplasmic matter remains present. Special mention should be made of certain frequently obtained cell-aggregates, which consist of Sertoli-cells with sperm-heads still attached. The behavior of these aggregates is peculiarly interesting and important from our present standpoint.

The spermatozoa constantly exhibit an active migration in the direction of the negative stream.¹ The direction of this movement is

¹ Other authors have incidentally observed and remarked upon the strong tendency of spermatozoa to travel with the negative stream under conditions

invariable and its rate is very uniform; in these respects spermatozoa present a marked contrast to leucocytes which, as shown above, exhibit great individual variability in respect to both direction and speed of migration. This constancy of behavior is evidently related to the constancy of organization of these cells, all normal spermatozoa being, so far as we can observe, almost exactly alike in size, structure, and chemical composition. The rate of migration is rapid (ca. 2 mm. per minute). This is the more remarkable when we consider that the shape of a sperm-head is such as to make its surface-area (and hence the frictional resistance to transfer through the medium) much larger than that of a spherical body of even considerably greater volume. The surface-area of such a sperm-head, regarding it as a cylinder with plane circular extremities and of the dimensions $30\ \mu$ by $3\ \mu$ is approximately 300 square microns; its volume is approximately 212 cubic microns. In the case of a spherical nucleus $10\ \mu$ in diameter (*e. g.* one of the thymus-nuclei considered above), surface and volume are respectively 314 square microns and 524 cubic microns. Thus for every unit of volume the sperm-head presents to the medium a surface of contact approximately two and one-half times greater than that presented by the most rapidly moving free nucleus. Nevertheless in actual rate of migration the two differ relatively slightly, their velocities being indeed very similar (1500 to 2000 μ per minute) under the above conditions. From this rough estimation, therefore, the inference seems clear that the substance of which the sperm-head is composed carries a negative charge of considerable potential. This confirms the expectation which we were led to form above from more general considerations.

A few large free cells, as a rule, in a more or less injured condition, are usually found among the organic debris in the fluid. Their reaction varies; they are frequently but not invariably positive. These relatively voluminous cells evidently correspond to the Sertoli-cells or foot-cells of the testis. Frequently they are obtained with a bundle of spermatozoa still attached (Fig. 1); it is then found when the current is made that the aggregate typically assumes the position represented in the figure, with the spermatozoa on the side directed toward the anode; the whole mass is then usually dragged slowly in the direction of the negative stream. On reversal of the current-direction, the entire aggregate slowly turns about through 180° and

similar to the above. See HERMANN: *Archiv für die gesammte Physiologie*, 1885, xxxvii, p. 459.

adopts the reversed position. At times the movement is of such a nature that the Sertoli-cell moves nearer the cathode, while the bundle of spermatozoa approaches the cathode; such a movement is practically one of rotation about a vertical axis, the position of the entire aggregate remaining almost stationary. At other times the bundle of sperm-heads tapers in such a way as to render the entire mass roughly club-shaped (Fig. 1). It is evident that such a mass, if under the influence of an attractive force acting equally on all its parts, would move through a resisting medium blunt end foremost, since at that region the ratio of surface to volume is least. Actually, however, when the aggregate travels toward the anode, the tapering

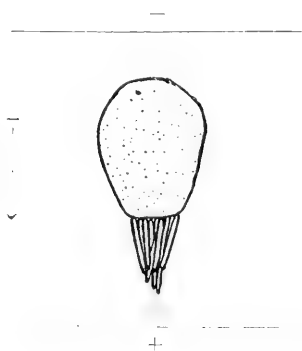

FIGURE 1. — Orientation and direction of movement of roughly club-shaped aggregate, consisting of Sertoli-cell with attached sperm-heads.

end is always found to assume the foremost position. This proves very clearly that the bundle of sperm-heads is much more strongly attracted than the body of the Sertoli-cell toward the anode. In other words, the sperm-nuclei are negatively charged relatively to the body of the cell. It is possible that consideration of this fact may throw light upon the nature of the peculiar relations subsisting between these two kinds of cells.

Blood-corpuses and spermatozoa are examples of free cells that may be examined in an uninjured condition. In the case of the remaining tissues whose properties I have examined, the histological elements are unavoidably more or less injured by the mechanical process of teasing. In all probability such injury produces alterations in the normal electrical behavior of the tissues (just as injured muscle becomes electro-negative towards uninjured muscle), hence relatively little stress can be laid on the results of the following experiments on portions of fresh tissues. The majority of such detached fragments exhibit a negative response: thus portions of fresh kidney tubules are found constantly negative; isolated ciliated cells of the oral epithelium are also negative, though slightly so; the same is true of such bodies as fat-globules, the majority of granules from the liver-cells, and yolk granules from the unripe ovary. On the other hand, fresh involuntary or heart muscle gives a positive response; if a freshly teased

fragment of muscle is so disposed that the direction of the fibres is perpendicular to the current-lines, the loose fibrils at the extremity of the fragment are found constantly to exhibit a movement in a positive direction (towards the cathode) whenever the current is made or its direction changed. In the case of voluntary muscle, the make of the current is typically followed by an active contraction of the cathodal side of the fibre, producing a curvature towards that pole; this obscures whatever movement may be due to simple electrical convection, leaving some doubt as to the actual direction of the latter. Small fragments of muscle frequently exhibit a negative direction of movement; this, however, is in all probability due to post-mortem alterations of the muscle-substance.

SUMMARY AND CONCLUSIONS.

On generalization from the above facts (so far as this is at present admissible) it appears (1) that free nuclei exhibit a strong tendency to migrate with the negative stream, and (2) that this tendency is strongest in those nuclei in which the proportion of nucleic acid is highest. These facts confirm the inference that the colloidal particles composing nuclear chromatin carry negative charges. Cells with voluminous cytoplasm tend, on the other hand, to exhibit the reversed direction of migration, indicating a prevailingly opposite condition of electrification of the cytoplasmic colloidal particles. This difference in electrical behavior corresponds to the general difference in the chemical properties of chromatin and cytoplasm and is in agreement with the demands of the above theory.

On considering the behavior of the chromatin in dividing cells, we meet with what must be regarded as additional evidence that this substance is composed of electrically charged particles. The movements of the chromosomes during mitosis are especially suggestive of the action of electrified particles; the relative positions assumed by these bodies with the cell, both while in the equatorial plate and after the longitudinal division is complete, seem to indicate very clearly the existence of a mutually repellent action between neighboring chromosomes similar to that which obtains between similarly charged bodies. The spiral form so characteristic of the chromatic filament before its segmentation, is open to the same interpretation; the adjacent portions of a filament composed of a linear series of similarly

charged colloidal particles¹ (here the "chromomeres") must also repel one another; hence the entire filament, if confined within a limited space — as is here the case, owing to the presence of a nuclear membrane — will naturally tend to assume a coiled or spiral form, since this is precisely the form in which the adjacent portions of the filament are as far as possible removed from direct contact with one another. It is possible to proceed still further, and to demonstrate that such a filament will divide equally and *longitudinally*, if division is regarded as the result of a lowering of the surface-tension of each particle following upon an increase in the expansive tension of its surface electrical charge.² The longitudinal division of the chromosomes, hitherto interpreted on essentially teleological grounds (following Roux and Weismann), appears on this theory susceptible of simple and adequate physical explanation. To pursue these considerations in further detail is, however, out of place in the present paper, and a more complete discussion is deferred. It is sufficient for the present to point out that electrical theories of mitosis, besides being an almost necessary outcome of our present knowledge of the colloidal constitution of living matter, are accorded the strongest support by a consideration of many of the most significant features of the process itself.

¹ For an accurate study of the structure of the chromosome, and the nature of its longitudinal division, see A. BRAUER: *Archiv für mikroskopische Anatomie*, 1893, xlii, p. 153. Compare WILSON: *The Cell*, Second Edition, p. 112, where figures from HERMANN and FLEMMING are also given. The chromatic filament is at present usually regarded as composed of numerous minute granules of chromatin, the chromomeres (here identified with colloidal particles), imbedded in a homogeneous ground substance (linin), and serially arranged in a single row like a chain of beads. The longitudinal splitting of the entire chromosome is held to be the end-result of the fission of each granule along a single division plane which lies parallel to the long axis of the chromosome. Brauer finds in the spermatocytes of *Ascaris megalocephala* a *double* longitudinal splitting of the chromatic filament, each granule dividing into four (probably by two successive divisions) which always lie in a single plane perpendicular to the length of the filament; they are of equal size and arranged to form the corners of a square (:::). This behavior is strongly suggestive of the division of a colloidal particle under the influence of its surface electrical charge and of the effects of mutual repulsion in keeping the products of division apart.

² For a discussion of the influence of the surface-tension of the colloidal particles and its alteration by electrical influences in determining the state of subdivision, see BREDIG: *Loc. cit.*, pp. 15-16.

SUMMARY.

1. Isolated cells and nuclei suspended in cane-sugar solution, through which an electrical current is passed, migrate in some cases with the negative stream, in others with the positive stream.

2. The majority of such structures migrate with the negative stream; this tendency is especially strong in free nuclei and structures consisting chiefly of nuclear matter.

3. The speed of migrations of sperm-heads, thymus-nuclei, and lymphocytes decreases in the order named, showing a parallelism with the decrease in staining property or degree of acidity of the chromatin.

4. Cells with voluminous cytoplasm — large leucocytes, many red blood-corpuses, involuntary muscle-cells, and in some cases Sertoli-cells — tend to move with the positive stream.

5. The possibility is pointed out that this difference may be due to a general contrast in the electrical properties of the colloids composing nuclear chromatin and cytoplasm respectively; a few of the possible consequences of such a condition are briefly indicated.

AN EXPERIMENTAL STUDY OF THE CHEMICAL
PRODUCTS OF BACILLUS COLI COMMUNIS
AND BACILLUS LACTIS AEROGENES.¹

BY LEO F. RETTGER.

(Research Scholar of the Rockefeller Institute.)

[From the Sheffield Laboratory of Physiological Chemistry, Yale University.]

THE colon bacillus and bacillus lactis aerogenes have been found to be of common occurrence in the human intestine. According to Escherich² and others, the bacillus lactis aerogenes predominates in the upper end of the small intestine in persons living on a milk diet, and especially in infants; in the lower end, on the other hand, it is outnumbered by the colon bacillus. Further, a disappearance of milk sugar from the contents of the intestine is accompanied by a disappearance of the lactis aerogenes organisms, or a decrease in their number. At the same time, there is found a relative increase in the number of colon bacilli. As the latter organisms are universally present in larger or smaller numbers in the human intestine, their mere presence may not be of much significance. But the question arises: May not these organisms, by virtue of their excessively great numbers, or of a peculiar kind or degree of activity, be the cause of certain disturbances in the animal body? If there is such a causal relationship between the colon bacillus and certain diseases, it is probable, in the light of recent investigations, that the immediate cause of the disturbances must be sought in the chemical products of the micro-organisms. Whether such a relationship exists is very difficult to demonstrate, and is as yet undetermined. It is of interest, however, to ascertain as far as possible the different products of decomposition, the relative quantities in which they arise, and the conditions of formation. Lastly, since the two micro-organisms under discussion are so closely related in their morphological

¹ This research was carried on with the aid of an appropriation from the Rockefeller Institute for Medical Research.

² ESCHERICH: Fortschritte der Medicin, 1885, iii, Nos. 16 and 17, pp. 515 and 547. (Abstracted in MALY's Jahresbericht, 1885, xv, p. 513.)

characteristics and distribution, a comparative study of the chemical products which they elaborate seems desirable.

Organisms employed. — The colon bacillus¹ which was chiefly used in this work was isolated from the intestinal contents of a patient suffering from pernicious anæmia, where it was found to be the predominating organism. For comparison, an ordinary stock culture of bacillus coli communis was employed. The bacillus lactis aerogenes² was obtained directly from the intestine of an infant.

Culture media. — The culture media, with the exception of the crystallized egg-albumin, were prepared in the laboratory of Dr. E. K. Dunham of New York. They were :

a. Dunham's peptone solution (1 per cent Witte's peptone and 5 per cent common salt).

b. Solutions of crystallized egg-albumin³ with varying amounts of different salts (sodium chloride, sodium hydrogen phosphate, magnesium sulphate, sodium aspartate, etc.).

c. Mixtures of finely chopped meat and coagulated egg-white suspended in water. They were prepared as follows : One pound of lean chopped beef and the whites of six eggs were employed for each litre of water used. The beef was mixed with half of the water, and the mixture heated to boiling, with sufficient stirring to prevent burning. The egg-whites were mixed with the other 500 c.c. of water and slowly added (with constant stirring) to the boiling meat mixture. After a brief period of thorough heating, the whole was made faintly alkaline to litmus paper, diluted with water to the original volume and sterilized.

Bacterial products. — The bacterial products sought for were albumoses and peptone, tyrosin, leucin, tryptophan,⁴ indol, skatol, phenols, aromatic oxy-acids, skatol-carbonic acid, hydrogen sulphide, mercaptan, and diamines (putrescin and cadaverin).

Conditions of growth and analysis. — In order to imitate to a certain degree the conditions which exist in the intestines, the culture materials were kept in an atmosphere of hydrogen, by allowing a slow current of the gas to pass through them. The decomposition was allowed to take place at incubator (body) temperature.

¹ Isolated by Dr. E. K. DUNHAM of New York.

² Likewise isolated by Dr. DUNHAM.

³ Pure solutions of egg-albumin were found to form very little precipitate on sterilization with steam. For methods of preparing crystallized egg-albumin, see HOPKINS and PINKUS : Journal of physiology, 1898-99, xxiii, p. 130.

⁴ See HOPKINS and COLE : Journal of physiology, 1901-02, xxvii, p. 426.

The egg-meat mixture was the most favorable of the culture media employed. In this medium decomposition was rapid and complete. In the peptone-salt solution the chemical changes were very slow, although the bacteria seemed to multiply fairly rapidly. In the solutions of pure egg-albumin and salts not even bacterial development was apparent to any marked degree, and this medium had to be rejected. Similar results were obtained with solutions of sodium caseinogenate.¹

After definite periods of incubation further growth was checked. The bouillon cultures were filtered into sterile bottles through a Chamberland filter, and the filtrates mixed with small quantities of chloroform. The cultures on solid media were kept in a cool place, and subjected to analysis as soon as possible. In some instances small quantities of chloroform were added. For analysis, comparable quantities of material were taken. The egg-meat cultures were not filtered, but were thoroughly shaken immediately before examination, in order to obtain a homogeneous suspension. Further details regarding the methods of analysis are given in the appendix.

While the results obtained in this study are essentially qualitative, an attempt was made to obtain an approximate quantitative idea regarding the occurrence of certain of the decomposition products of the organisms, under varying conditions. In the case of indol and skatol, comparative coloration and dilution methods were used. By employing definite quantities of distillate, and diluting with known quantities of water, regular gradations were obtained in the colors which are produced by nitric acid (indol) and sulphuric acid (skatol). For the sake of convenience and uniformity, the phenols were estimated in an analogous manner (Millon's reagent). As no satisfactory methods exist for the determination of aromatic oxy-acids and skatol-carbonic acid, a coloration method was likewise employed for them.

In every trial with the liquid media (bouillon and egg-albumin solutions) the amount of decomposition which occurred was slight; and with the exception of the formation of indol, skatol, and aromatic oxy-acids, the chemical changes were so insignificant as to be regarded within the limits of error. Small quantities of indol, skatol, and

¹ TAYLOR has recently shown that *Bacillus coli communis* fails to produce extensive decomposition in casein, while *Proteus vulgaris*, on the other hand, decomposes it energetically. *Zeitschrift für physiologische Chemie*, 1902, xxxvi, p. 487.

aromatic oxy-acids were present, however. Cultures of varying ages (one to four weeks) were employed. The following discussion will therefore be confined to the products occurring in the egg-meat mixtures.

GENERAL RESULTS.

Bacillus coli communis. — Within two to three weeks the egg-meat mixtures had undergone very marked transformation. The mass of solid matter was extensively disintegrated, leaving only a small residue of coarse particles. A very strong and disagreeable odor, more intense than in any of the older cultures, was emitted on opening the flasks.

Indol was present in large quantity; 10 c.c. of the distillate (500 c.c.) gave a deep red or cherry-red color with nitric acid. This color was still perceptible after dilution with ten volumes of water. Only a small amount of skatol was found, the distillate (500 c.c.) giving only a pink color with sulphuric acid. Phenols were present in considerable amounts, giving a distinct color reaction after five dilutions of the distillate (500 c.c.). The ether extracts of the decomposition fluids had a very strong odor of aromatic oxy-acids. On chemical examination, a pronounced reaction was obtained in the first extraction fluid (250 c.c.), while in the second fluid (500 c.c.), the reaction was still quite marked. (See appendix, p. 291). Only a small percentage of the acids appeared to be para-oxy-phenyl acetic, the remainder being largely para-oxy-phenyl propionic acid.

Skatol-carbonic acid was present in large quantities, as indicated by the strong reactions with ferric chloride and hydrochloric acid. The reaction was marked even in the second extraction fluid (500 c.c.).

Two crops of leucin and tyrosin crystals were obtained from the liquid. The first (principally tyrosin) weighed 3 grams; the second (principally leucin), 4 grams. On further purification, the characteristic crystals of each were obtained separately.

Albumoses and peptone occurred in very small amount, and only slight reactions could be obtained for them.

Tryptophan was very easily detected, and considerable purple precipitate was formed with bromine water. An alcoholic extract of this precipitate possessed the characteristic color.

Hydrogen sulphide and mercaptan were present in relatively large

quantity. The combined precipitates of mercury mercaptid obtained from 300 c.c. decomposition mixture weighed 0.2 gram.

By the method described for diamines in the appendix, a crystalline precipitate of about 0.3 gram was obtained; it consisted of small fine needles of a light yellow color, melting at 60° C. Since putrescin and cadaverin both have a melting point of over 100° C., it was evident that they did not constitute this precipitate, and were presumably absent from the putrefaction material.

As the egg-meat cultures grew older, the transformation was still more marked. Flasks which had been incubated three to four weeks contained less of the coarse material than the preceding. No indication of the presence of albumoses and peptone could be obtained. The amount of mercaptan was small, yielding a precipitate of only 0.011 gram of mercury mercaptid. There was a decrease in the quantity of all the intermediate products, except tyrosin, leucin, and indol.

In cultures still older, the disappearance of the molecularly large decomposition products was very conspicuous. In flasks which had been incubated ten weeks, a moderate amount of indol was present; no skatol or phenols, and only a trace of mercaptan was observed. The odor of the mixture was only slightly offensive. While tyrosin was still present in considerable quantity, very little leucin was obtained. There was no indication of albumoses or peptone. Aromatic oxy-acids and skatol-carbonic acid were present in moderate quantities only, as compared with cultures two to three weeks old. No diamines were found.

A decomposition mixture which was four months old was found to be thoroughly disintegrated, and of fluid consistency. The odor was only slightly offensive. While no skatol or phenols could be detected, the amount of indol in this instance was very large. Not a trace of mercaptan could be detected. A moderate amount of aromatic oxy-acids and of skatol-carbonic acid was still present. No albumoses or peptone were obtained, and leucin and tyrosin were absent, or present in traces only. On final concentration of the culture liquid a residue was obtained which contained comparatively little organic material. Evidently the decomposition in this instance was very complete.

A comparison of the products of this isolated colon bacillus with those of another (stock) culture, grown in the same media, and under the same conditions, showed a striking similarity in the mode of decomposition inaugurated by the two organisms. The transformation

of the culture media, however, was much slower when the latter organism was employed, and consequently the amounts of the different products in the early stages of decomposition were smaller than when the cleavages were brought about by the organism recently obtained from the intestinal tract.

Bacillus lactis aerogenes. — The production of mercaptan, skatol, phenols, aromatic oxy-acids and skatol-carbonic acid was much slower and less pronounced than in corresponding cultures of the colon bacillus. This was not due to any failure of the organism to decompose the proteid material present, as the amounts of tyrosin and leucin, and even of indol, in such mixtures were large, and the mixtures themselves had undergone disintegration.

In cultures two to three weeks old, no mercaptan could be detected. The odor was not at all offensive as compared with corresponding colon cultures. Very little skatol and no phenols were observed. Indol was detected in considerable quantity, while the quantities of aromatic oxy-acids and skatol-carbonic acid were very small. Leucin and tyrosin were quite abundant. The presence of albumoses and peptone was indicated, although in small amounts.

As decomposition continued the quantities of the different products gradually increased. In cultures eight to ten weeks old a small amount of mercaptan was observed. There was a trace of skatol and phenols, and a moderate quantity of aromatic oxy-acids present. Indol was very abundant; and a large mass of tyrosin crystals with only little leucin was obtained. Albumoses and peptone were present in very small amount, while the presence of tryptophan was readily demonstrated.

SUMMARY.

1. *Bacillus coli communis* and *Bacillus lactis aerogenes* fail to bring about very marked decomposition in peptone-bouillon. On the other hand, an egg-meat mixture undergoes rapid and extensive transformation.

2. Common products of the colon bacillus are indol, skatol, phenols, aromatic oxy-acids, skatol-carbonic acid, hydrogen sulphide, mercaptan, tyrosin, leucin, and tryptophan. Albumoses and peptone are present in very small amounts. This fact is contrary to general belief. It has been assumed that albumoses and peptone occur abundantly among putrefaction products. Fermi and Pampersi¹

¹ FERMI and PAMPERSI: Jahresbericht für Thierchemie, 1897, xxvii, p. 827.

go to the other extreme, however, and contend that bacteria are unable to peptonize proteids. A more plausible idea presents itself: namely, that bacteria do peptonize proteids, but that the albumoses and peptone formed are immediately broken up further by the organisms or their enzymes, and therefore are detected with great difficulty. Diamines were not found in the putrefaction mixtures. This fact is in harmony with the observations of Garcia¹ and others who failed to find diamines in ordinary intestinal putrefaction.

3. *Bacillus coli communis* causes more rapid and more profound decomposition than *Bacillus lactis aerogenes*. While the former produces its optimum results within two to three weeks (under favorable conditions), the *lactis aerogenes* organism requires eight to ten weeks to bring about comparable results. Indol is a product of both organisms, while the colon bacillus alone produces mercaptan and phenols during the first few weeks.

4. When the bacterial digestion progresses beyond a certain point, the intermediate products (peptone, amido-acids, indol, etc.) gradually disappear from the mixtures. Indol may, however, persist for a long time. This disappearance of the more intermediate products is evidently due to their further cleavage and the formation of still simpler bodies, yielding ultimately carbon dioxide, water, methane, etc.

It may be objected that in the intestine the period of decomposition is much shorter than in these experiments, and that therefore the results here obtained do not illustrate what actually occurs there. This is in large part true; it is not feasible, however, to examine by chemical means putrefaction materials which are only twenty-four to forty-eight hours old, since the various characteristic products occur in such small amounts as to escape detection. In the intestine, on the other hand, the conditions are all favorable to rapid decomposition. Here putrefaction is doubtless facilitated by the presence of digestive juices and their products, by the peculiar character of the intestinal contents, and by the movements of the alimentary canal.

I am indebted to Professors C. A. Herter, E. K. Dunham, and L. B. Mendel for the valuable assistance which they have given me in this investigation.

¹ GARCIA: *Zeitschrift für physiologische Chemie*, 1893, xvii, p. 588.

APPENDIX. — METHODS OF ANALYSIS.

a. **Liquid media.** — *Total acidity.* — Titration with $\frac{1}{10}$ KOH (phenolphthalein, indicator).

Volatile acids. — Distillation with phosphoric acid, and titration of distillate.

Ammonia. — Distillation with magnesium oxide, and titration of distillate with $\frac{1}{10}$ H₂SO₄.

Albumoses. — Precipitation with zinc sulphate,¹ and determination of nitrogen in precipitate by the Kjeldahl-Gunning method.

Peptone. — Precipitation of the albumose-free solution with bromine,² and determination of nitrogen by the Kjeldahl-Gunning method.

Indol, skatol, phenols, and aromatic oxy-acids. — Distillation with steam, etc., as described for solid media.

b. **Solid media.** — Three different portions from each culture flask are employed: one for the isolation and detection of indol, skatol, phenols, aromatic oxy-acids, skatol-carbonic acid, tyrosin, leucin, albumoses and peptone, and tryptophan — (I); another for the study of hydrogen sulphide and mercaptan — (II); and the third for the isolation and identification of diamines — (III).

I. *Indol, skatol, phenols, etc.* — Portions of 400 c.c. of the decomposition mixture are diluted with an equal volume of water, and after the addition of 5 c.c. of dilute sulphuric acid, are distilled with steam until 600–700 c.c. of distillate have formed. The distillate is made alkaline with potassium hydrate, and again distilled with steam until 500 c.c. of liquid have collected — (A). Indol and skatol are in the distillate. The last distillation residue is saturated with carbon dioxide gas,³ and distilled until 500 c.c. of liquid have collected — (B). Phenols are in this distillate.

For the estimation of indol, definite quantities of distillate A are diluted with known quantities of water until such a degree of dilution is obtained that the color reaction with nitric acid is only slight.⁴ The amount of dilution required is an index to the approximate quantity of indol present. Skatol gives no color reaction with nitric acid; it is estimated in a manner

¹ Method of BÖMER. See ZUNZ: Zeitschrift für physiologische Chemie, 1899, xxvii, p. 220.

² ALLEN: Commercial organic analysis, 1898, iv, p. 320.

³ HOPPE-SEYLER und THIERFELDER: Handbuch der physiologisch- und pathologisch-chemischen Analyse, 1893, p. 158.

⁴ For color reactions of indol, skatol, phenols, aromatic oxy-acids, and skatol-carbonic acid, see SALKOWSKI'S Praktikum der physiologischen und pathologischen Chemie, 1900.

analogous to that of indol, sulphuric acid being used instead of nitric to produce the color reaction.

For the estimation of phenols, distillate B is diluted in the same manner as A, and the color reaction is brought about by Millon's reagent.

Aromatic oxy-acids and skatol-carbonic acid.—The liquid remaining after the first distillation is filtered, concentrated, and again filtered; it is then extracted with ether, to remove the aromatic oxy-acids and skatol-carbonic acid. The combined ether extracts are filtered, and the ether removed by evaporation. The oily residue is extracted with warm water, and the solution filtered and distilled with steam.¹ The distillation residue is again concentrated and extracted with ether. After evaporation of the ether, the residue is extracted twice with warm water—250 c.c. and 500 c.c. Both of the aqueous extracts are examined for aromatic oxy-acids and skatol-carbonic acid.

Tyrosin, leucin, albumose, peptone, and tryptophan.—The fluid residue remaining after the removal of the aromatic oxy-acids and skatol-carbonic acid is concentrated to the point of crystallization. After cooling, the crystalline mass is examined for tyrosin and leucin.² A second crop of crystals is obtained in the same manner.

After the removal of tyrosin and leucin, the syrup is treated with four to five volumes of 95 per cent alcohol; albumoses and peptone are precipitated, along with certain salts. The precipitate is washed with alcohol, dissolved in water, and the solution tested for albumoses and peptone.³

For the isolation and detection of tryptophan, the alcoholic filtrate and washings from the last precipitate are concentrated in order to remove the alcohol, acidified with acetic acid, and treated with 10–12 c.c. of bromine water. Tryptophan is precipitated as a purple bromine compound,⁴ which dissolves in alcohol, imparting the characteristic color to the solution.

II. *Hydrogen sulphide and mercaptan.*—In order to eliminate any error arising from the presence of hydrogen sulphide formed in the sterilization,⁵ a current of air or hydrogen should be passed through the culture medium before inoculation, and while the medium is being warmed at 50°–60° C.

¹ To remove any traces of phenol that may still be present; see SALKOWSKI: *Zeitschrift für physiologische Chemie*, 1879, ix, p. 8.

² See HAMMARSTEN: *Textbook of physiological chemistry* (translated by MANDEL), 1900, p. 62.

³ HAMMARSTEN: *Loc. cit.*, p. 33.

⁴ KURAJEFF: *Zeitschrift für physiologische Chemie*, 1898–99, xxvi, p. 501.

⁵ RETTGER: *This journal*, 1902, vi, p. 450.

Mercury cyanide precipitate.—An equal volume of water is added to 300 c.c. of the decomposition mixture in a litre flask. The flask is connected, on the one hand, with a small precipitating bottle containing a 3 per cent solution of mercury cyanide, and, on the other, with a wash bottle partly filled with permanganate solution. The decomposition material is then acidified with 10 grams of oxalic acid, and warmed for two to three hours at 40°–50° C. During the warming a current of air is slowly drawn through the flasks. Hydrogen sulphide comes over first, and produces a black precipitate in the cyanide solution. Finally the mercaptan passes over, and its presence is indicated by a gray to light-green precipitate in the cyanide bottle. By replacing the mercury cyanide with fresh solutions, the precipitates with these two volatile bodies are obtained separately. They are washed, dried, and weighed.¹

*Mercaptan-isatin reaction.*²—A small quantity of isatin is dissolved in concentrated sulphuric acid. On passing mercaptan gas through this solution it is colored grass-green. The reaction is a very delicate one, and is in no way interfered with by any of the other ordinary decomposition products. The method of detection is somewhat similar to the cyanide method; the isatin solution is substituted for the cyanide, and calcium chloride drying tubes must be employed to prevent any moisture from entering the isatin solution.

III. *Diamines.*—The benzoylation method, as described by Garcia,³ was employed.

ADDITIONAL REFERENCES.

- BAUMANN and BRIEGER: *Zeitschrift für physiologische Chemie*, 1879, iii, p. 149.
BRIEGER: *Zeitschrift für physiologische Chemie*, 1882–83, vii, p. 274; 1883–84, viii, p. 306; 1885, ix, p. 1.
SALKOWSKI: *Zeitschrift für physiologische Chemie*, 1883–84, viii, p. 417; 1885, ix, p. 8.
HIRSCHLER: *Zeitschrift für physiologische Chemie*, 1886, x, p. 306.
NENCKI: *Monatshefte für Chemie*, 1889, x, p. 506.
SELITRENNY: *Monatshefte für Chemie*, 1889, x, p. 908.
BLUMENTHAL: *Zeitschrift für klinische Medizin*, 1895, xxviii, p. 223.
EMMERLING: *Berichte der deutschen chemischen Gesellschaft*, 1897, xxx, p. 1863.
MORRIS: *Archiv für Hygiene*, 1897, xxx, p. 304.

¹ NENCKI and SIEBER: *Monatshefte für Chemie*, 1889, p. 526.

² NIEMANN: *Archiv für Hygiene*, 1893, xix, p. 126; also BAUER: *Zeitschrift für physiologische Chemie*, 1902, xxxv, p. 346.

³ GARCIA: *Zeitschrift für physiologische Chemie*, 1893, xvii, p. 571.

ELECTRICAL POLARITY IN THE HYDROIDS.

By ALBERT P. MATHEWS.

[From the Hull Physiological Laboratories of the University of Chicago.]

IT has long been known that many animals and plants possess a marked physiological polarity, but the cause of that polarity is still undetermined. As an extended discussion of this subject is to be found in Morgan's treatise on "Regeneration,"¹ it is unnecessary to enter into detail here, but the following particular examples may be mentioned as more especially bearing on my own work. The point of most rapid regeneration in pieces of *Planaria* and other organism appears to be determined in part by the shape of the piece, being sometimes in the centre of the cut surface, sometimes at one side of the centre; and the differentiation of the new tissues appears to depend, in part at least, on the position of the surface of regeneration in relation to the whole piece. The same tissues will, if that surface be anterior, regenerate a head; if posterior, a tail. In the hydroid, *Parypha*, a piece of the stem which shows no optical difference between the two ends, nevertheless regenerates the polyp more rapidly from the polyp end of the piece, than from the stolon end. In grafting many plants, it has been found far more difficult to graft two stem surfaces together than stem with root.

The marked resemblance of animal and plant polarity to that of a magnet suggested that it might be possible to detect and measure the amount of this polarity by purely physical means, on the assumption that the polarity was electrical in nature, or gave rise to electrical differences. This hypothesis was supported by several facts. It is well known that electrical differences exist between two portions of an organ, or animal, which are unequally active. Such electrical differences have been observed in glands, in epithelia, in nerves, in muscles, and in other tissues. If there is a difference in the rate of chemical or physical change between the two ends of a hydroid, it should be possible to detect it electrically. Furthermore, in plants

¹ MORGAN: *Regeneration*, Macmillan and Co., New York, 1901.

similar electrical differences have been observed between the mid-rib and the edges, and between the upper and lower surfaces of leaves, and have been studied by Burdon-Sanderson¹ and others. In the roots of the spinal nerves, Mendelssohn² has discovered that a small but definite difference in potential exists between the two cut transverse surfaces of a piece of nerve. In a piece of the anterior roots, the peripheral surface is always negative to the central; while in the posterior roots, the peripheral surface is positive toward the central surface. In other words the spinal nerves are definitely polarized, and although the two surfaces look alike, they differ electrically. Finally Du Bois-Raymond³ long ago showed that in a prism of muscle the point of greatest negativity was determined by the shape of the piece of muscle, as will be pointed out farther on. These facts are apparently so strikingly parallel to the facts of regeneration, and the physiological effects of such small differences in electrical potential are so well recognized, that it seemed not impossible that animals might show an electrical, corresponding to and causing their physiological, polarity.

Observations were made chiefly on the tubularian hydroid, *Parypha*, though several other hydroids were examined. The hydroids are very suitable for such observations, owing to their well marked polarity and their lack of motility. The electrodes used were zinc-zinc sulphate, clay electrodes of Du Bois-Raymond, the clay being moistened with $\frac{5}{8}$ *n* sodium chloride solution, making them isosmotic with the sea-water. The electrodes were isoelectric. The current was detected by means of a delicate capillary electrometer designed by Porter.

When a piece of the stem of *Parypha* one half or one inch long was placed with its cut surfaces on the two electrodes, it was found invariably that the polyp surface was electro-negative to the stolon surface. A current passed through the electrometer from the stolon toward the polyp end. The current was always in this direction in all stems examined, and was invariably reversed through the electrometer when the piece of stem was reversed on the electrodes. The amount of this current is variable, depending on the age of the piece and the

¹ BURDON-SANDERSON: Cited from MENDELSSOHN, *Dictionnaire de physiologie*, edited by RICHEL, vol. v, p. 386.

² MENDELSSOHN: *Dictionnaire de physiologie*, edited by RICHEL, vol. v, p. 335.

³ DU BOIS-RAYMOND: Cited from MENDELSSOHN: *Loc. cit.*, p. 325.

position it occupies in the stem. In pieces of old stem taken near the stolon, hardly any difference is to be detected. The difference is greater the fresher the hydroid. It is also greater in pieces of young stem taken with one surface just behind the polyp. If the polyp itself is crushed against one electrode, the cut surface being on the other, a maximum difference is obtained, the polyp being very strongly negative. The movement of the meniscus in the electrometer was measured by a micrometer eye-piece and was, in the most favorable instances, in pieces one inch long, about one-third the maximum movement, which the same electrometer showed when the electrodes were on the cut and longitudinal surface of the frog's sciatic nerve. The current was probably about 0.005 volt.

Other hydroids, *i. e.*, Pinnaria and Campanularia, showed the same negativity of the polyp surface, but in these forms the amount of difference was a good deal less than in Parypha. In the hydroids, therefore, the more rapid regeneration occurs at the point of greatest negativity.

Morgan observed that in Planaria or Fundulus the point of most rapid regeneration was apparently determined by the shape of the piece, or of the cut surface. If, for example, a planarian be cut at right angles to the long axis of the body, the most rapid growth occurs at the middle of the cut surface; if it be cut obliquely, the most rapid growth occurs at the acute angle. Similar facts are observed in the regeneration of the tail of Fundulus. These facts recall Du Bois-Raymond's observations on the electrical relationships in a piece of muscle. If a muscle is cut perpendicularly to its longitudinal surface, the point of greatest negativity is to be found in the centre of the cut surface. If the muscle is cut obliquely, the point of greatest negativity is at the acute angle.

I think the similarity of these observations to Morgan's will be apparent. While it was impossible, owing to the small size of Planaria, to prove that the acute angle was negative to the obtuse in pieces cut obliquely, and unsatisfactory results were obtained also in Cerebratulus, I found that such electrical differences existed in oblique sections of the tail of Fundulus. Although not detected in Planaria, I believe it to be probable that the body of the Planarian does not differ essentially in this respect from that of Fundulus and the muscle prism, particularly as the regeneration phenomena resemble each other in the two cases. In Fundulus at any rate, and probably in Planaria, we find hence the same law as in the hydroids, *i. e.*, re-

generation takes place with greatest rapidity at the point of most marked negativity; and furthermore, the point of most marked negativity is determined in part by the shape of the piece.

I endeavored to test experimentally the conclusion that regeneration takes place most rapidly at the most negative point, by placing pieces of hydroid stems in sea-water and passing an electrical current through the water, with some of the stems turned with the polyp end toward the current, others turned with the stolon end toward the current, in the hopes of neutralizing or increasing the negativity of the polyp end. The experiments were interrupted by other work, and I cannot speak positively without further tests, which it is hoped may be tried next summer, but in many cases pronounced inhibition of development was obtained when the polyp end was turned toward the current.

It may be asked how the fact that one point is negative toward another can influence the rate of regeneration. It is possible the process may be as follows: The original difference of potential between the cut surface and the uninjured portion of the protoplasm is caused partly by the shock of the cut, partly by the new environment for the protoplasm of the cut surface. Just which point of the cut surface shall be most negative is determined by the position of the point relative to the mass of the piece and the totality of uninjured and injured points. The electrical differences thus set up cause currents which are closed through the surrounding cells, and these currents, though small, profoundly influence all the processes in these cells.

It is not probable that the electrical disturbances here described are the accompaniment of injury only. On the contrary, it has been shown that they exist also in the intact organism. Every excess of action, every change in physical state of the protoplasm of any organ, or of any area in the embryo or in the egg produces, it is believed, an electrical disturbance. Electrical tensions are set up in the adult or throughout the embryo. This electrical disturbance, rendering one part of the animal negative or positive to another part, must cause electrical currents, *i. e.*, the movements of ions in the surrounding cells or protoplasm. In my opinion, the importance of the electrical currents thus set up physiologically in the normal animal by varying activities in its organs, has not been properly recognized. These currents probably play a larger part in the determination of rates of growth, in the orientation or polarization of the cells, and the differ-

entiation of the organism, in its polarity, in other words, than has been supposed. That electrical currents do have such a profound effect on the state of protoplasm is shown by the well-known electrotonic effects in muscle and nerve. A momentary exposure of a sympathetic nerve to the anode will often block conductivity at this point for minutes, or even hours. The directive action of a current on infusoria is known to all. The amount of current necessary to produce electrotonic effects is very small. Mendelssohn found that in nerve, 0.0001 milliamperes was sufficient.

Bearing these facts in mind and remembering the undoubted existence of an electrical polarity in the hydroids, is it not possible that the directive "pull" exerted by one part of an animal on another, of which Morgan speaks, is really due to these differences of electrical potential between the parts of the organism? From this point of view, the observations of Roux on the varying degree of polarization in the different cells of the frog's egg, and the transportation of material in the cells by electrical currents, derive additional importance.

Finally, if the rate of regeneration is thus conditioned by the state of the protoplasm in the neighborhood of the injury, it ought to be possible to alter that state at will, and hence increase or decrease regeneration. The control of this process offers one of the most attractive fields of physiological research.

The observations recorded in this paper were made at the Marine Biological Laboratory at Wood's Holl.

SUMMARY.

1. A difference of electrical potential exists between the cut-surfaces of the stems of the hydroids *Parypha*, *Campanularia*, and *Pinna*, the head, or polyp surface, being always negative to the stolon surface. The amount of this difference is variable, at its maximum being approximately one-third the current of injury in the frog's sciatic nerve.

2. Physiological polarity of these hydroids is hence accompanied by an electrical polarity, and may be quantitatively measured by physical means.

3. The amount of the current depends on the position of the stem, whether the piece examined comes from the neighborhood of the polyp, or the stolon; whether old or growing; whether fresh or

dying; being at its maximum in fresh, growing stems when one surface is taken near the polyp.

4. The point of most rapid regeneration corresponds here to the point of maximum negativity.

5. In *Fundulus*, and probably also in *Planaria*, the point of greatest negativity also corresponds with the point of greatest regenerative power. The most negative point is determined, among other factors, by the shape of the piece, or the relation of the cut surface to the whole animal. Probably the point of greatest negativity determines the point of most rapid regeneration, and thus explains the relationship of regeneration to the shape of the piece as noted by Morgan.

6. These facts indicate, in the author's opinion, that the so-called physiological polarity of the embryo or adult is due, in a measure at least, to the electrical differences or currents set up by unequal degrees of activity in the protoplasm at different regions. These currents traverse the surrounding protoplasm or cells, and, like any constant current applied from outside, polarize the protoplasm or cells in a definite way, causing alterations in their metabolism, and in the distribution of the cell contents analogous to the electrotonic effects in muscle, nerve, and infusoria.

THE IMPORTANCE OF MECHANICAL SHOCK IN PROTOPLASMIC ACTIVITY.

BY A. P. MATHEWS AND B. R. WHITCHER.

[From the Hull Physiological Laboratory of the University of Chicago.]

MECHANICAL shocks caused by the beating of the heart, muscular movements, the jar of walking, and the vibrations of the floors of buildings and vehicles of transportation are among the most constant stimuli of the body cells, and it is an interesting question to what extent they influence cell life. Meltzer¹ has especially discussed this question and contributed to our knowledge of the influence of agitation on animal cells and bacteria. A summary of previous work will be found in his paper.

It might at first be thought that such small shocks as those caused by the beating heart would be of no importance in the life-processes of the body cells, but that even very small shocks may profoundly influence cell metabolism is shown by the observations of one of us² on the star-fish egg, in which the most careful transfer of the eggs from one dish to another is often sufficient to set up artificial parthenogenesis in a certain proportion of eggs and by similar observations by Fischer³ on the eggs of *Amphitrite*. That the unfertilized egg is in respect to its susceptibility to mechanical disturbance in a particularly unstable condition is perhaps true, but the following observations on the small and hardy eggs of *Arbacia* show that even after fertilization an exceedingly small mechanical disturbance is often sufficient profoundly to change the rate of development and the physical characters of the embryos. As a result of our work we have become convinced of the probable truth of Meltzer's opinion concerning the importance of mechanical shock in the life history of body and other cells.

The question thus raised is of considerable practical importance. For example, what effect has the constant vibration of the floors of

¹ MELTZER: *Zeitschrift für Biologie*, 1894, xxx, p. 3.

² MATHEWS: *This journal*, 1901, vi, p. 142.

³ FISCHER: *This journal*, 1902, vii, p. 301.

mills on the length of life, the vital resistance, and physiological functions of mill-operatives? How far will mechanical jarring account for the digestive and vasomotor disturbances many suffer in railway travel? Are the motor-men and conductors of street-railways influenced by the repeated and violent shocks to which they are constantly subjected?

I. THE EFFECT OF A SINGLE SMALL OR LARGE SHOCK ON THE DEVELOPMENT OF ARBACIA EGGS.

The eggs were transferred from one dish to another both before and after fertilization, and were either squirted vigorously with a medicine dropper, or they were dropped into water from a height of from one inch to three feet, or they were carried carefully from dish to dish with a large-mouthed pipette, the end of which was placed under water before discharging the eggs.

The general result obtained in a large number of experiments was as follows: In certain conditions of the eggs, particularly at the beginning and end of the egg-laying season, and apparently when the temperature was low, *i. e.*, 15° – 19° C., the act of transfer, when performed even with the greatest care, will prevent practically the whole of the eggs from forming plutei. They develop into abnormal, opaque gastrulæ, often evaginated, often flat and with crenated edges, live for several days, swim, as a rule, at the bottom of the dish, and then die, generally developing no skeleton at all, or at the best but irregular spicules. At other times, however, particularly during the middle of the season, or when the temperature is high, *i. e.*, from 20° – 25° C., the act of transfer, even when roughly performed, has no effect at all, or it may produce an acceleration of development. In other words, the eggs are more susceptible at some times than at others, and are apparently rendered more sensitive by an exposure to a temperature of 18° – 20° . The exact relationship to temperature changes we hope to work out next summer, our results in this respect being still incomplete.

The increased susceptibility of the eggs brought about by a low temperature confirms Greely's¹ observations on *Asterias*, where he found that mechanical shock and cold together were more efficacious in causing artificial parthenogenesis than cold or shock alone. Our results parallel, also, observations made on motor nerves, which are

¹ GREELY: Personal communication, 1902.

similarly increased in their excitability by a low temperature. The most probable explanation of the action of mechanical shock on the egg substance we believe to be that already offered by one of us for nerves,¹ *i. e.*, that a single shock causes a partial gelation of the colloids of the egg substance. It produces the same effect on the protoplasm as cold, and the two processes accordingly supplement each other. This conclusion is, we believe, strengthened by Mrs. Andrews'² observations on living protoplasm. She observed that mechanical shock caused a distinct change in the viscosity of the protoplasm of the choano-flagellates, a very small jar causing the collar to become rigid. I believe Mrs. Andrews has seen and described better than any one else the changes in the state of *living* protoplasm, and has painted a more faithful picture of its extraordinary changes in viscosity, and of its constant flux.

The following experiments will illustrate the general character of the results obtained on *Arbacia*:

Experiment II.—August 17. Temperature, 19° C. *Arbacia* eggs were fertilized at 2 P. M.

Lot A. The eggs were left in the dish in which they were fertilized. They develop into normal gastrulæ and plutei.

Lot B. These were transferred, and squirted from a pipette into a second dish of water five minutes after fertilization. The early development corresponds to A; but they form gastrulæ of irregular shape, become crenated on the edges, and form no skeletons except in a few isolated instances.

Experiment XIX.—August 27. Temperature, 26° C. *Arbacia* eggs fertilized at 3.08 P. M.

Lot A. Not transferred. Form normal plutei.

Lot B. Transferred carefully with a large pipette at 3.10 P. M. Form large normal plutei.

Lot C. Dropped two inches into sea-water at 3.10. Many form abnormal gastrulæ and plutei, but the majority are normal.

Lot D. Squirted violently with a small pipette into sea-water. Form normal plutei like control.

Experiment III.—August 17. Temperature, 19° C. A different female than Experiment II. Conditions and results the same as in II.

¹ MATHEWS: *Science*, N. S., 1902, xv, pp. 492-498.

² ANDREWS: *Journal of morphology* (supplement), 1897, xii, p. 112.

II. THE EFFECT OF REPEATED SHOCKS AND SHAKING.

The effects of vigorously shaking the fertilized or unfertilized eggs will, of course, depend on the violence and length of time they are shaken. No accurate machine for shaking was at our disposal, so that we had to shake with the hand. The eggs were brought into a test tube half-filled with sea-water, and this was shaken briskly back and forth from ten to twenty times. The results obtained were variable, like those of the preceding section, depending, so far as we could discover, in part on the temperature and in part on some unknown condition of the egg substance. Certain results indicated that possibly the degree of aeration which the sea-urchins had had before being used was one of the determining factors. A further examination of this possibility we hope to make next summer.

In general, our results may be summarized as follows :

1. The unfertilized eggs are far more easily disorganized by shaking than the fertilized. This result was constant. If two lots of eggs were taken from the same female, one lot unfertilized, the other fertilized at least ten minutes earlier, the unfertilized eggs could be shaken to pieces before the fertilized were markedly affected.

2. Indications, in many cases very striking, were obtained that there is a definite rhythm in the resistance of the eggs to shaking after fertilization. Immediately after fertilization, *i. e.*, thirty seconds to three minutes, the eggs were shaken to pieces even more readily than unfertilized eggs. Their resistance then enormously increased, and at ten minutes they were very resistant. At twenty or thirty minutes their susceptibility had again in part returned, but it never reached the susceptibility of unfertilized eggs.

The increased resistance of the fertilized eggs was also observed by Meltzer¹ independently of us. He suggested that the unfertilized eggs were more brittle. One of us has already remarked on the ease with which matured star-fish eggs may be disorganized by shaking, while the immature are very resistant. The means of controlling the shaking accurately were wanting, so that we are unable to speak with certainty concerning the rhythm described above. We believe, however, that the explanation of the greater susceptibility of the unfertilized eggs is due to the greater viscosity of its protoplasm, and that the alterations in susceptibility described above were probably

¹ MELTZER : Personal communication.

due to the rhythmic change in the viscosity of the protoplasm as described by Mrs. Andrews.¹ Her observations apparently coincide with ours, though it was impossible, owing to her failure to give the time data, to compare in detail our results with hers. It would be surprising if such a variation in susceptibility during the process of fertilization did not exist, since not only has Mrs. Andrews described histological changes in the texture and viscosity of the protoplasm at this time, but the experiments of Lyon² show that there is such a rhythmic variation in the susceptibility of the eggs to lack of oxygen and potassium cyanide, and Spaulding³ has recently shown the same rhythmic susceptibility to acids and the anæsthetics. The method of mechanical shaking may thus throw light on variations in the physical consistence of the egg protoplasm.

3. Besides thus establishing variations in the resistance of the eggs to shaking before and after fertilization, we obtained well-marked results on the speed and course of development. Morgan⁴ some years ago observed that star-fish eggs which were shaken before fertilization developed more rapidly than those fertilized without shaking. We have confirmed this observation in *Arbacia* in some cases. Shaking these eggs ten to twenty times briskly, either before, or just after fertilization, may produce either of two results, depending apparently on the variable factors already discussed in Part I. The eggs are either accelerated in their development and form plutei larger than normal, or highly abnormal gastrulæ are obtained which never form plutei. In some cases, of which the following experiment is an example, a small shock prevented the pluteus development of nearly all the eggs, while a brisk shaking, not severe enough to destroy them, caused them to develop better than the control. This was true whether the eggs were shaken before or after fertilization.

Experiment XXIII.—September 1. Temperature of room, 24° C. Fertilized 11 A. M. All eggs from the same sea-urchin. Temperature of water during transfer, 19°.

1. Control. Not transferred. Eggs taken with great care from sea-urchin. September 3. Nearly all are normal plutei.
2. Transferred carefully *before* fertilization.

¹ ANDREWS: Journal of morphology (supplement), 1897, xii, p. 80.

² LYON: This journal, 1902, vii, p. 56.

³ SPAULDING: Personal communication; results not yet published.

⁴ MORGAN: Anatomischer Anzeiger, 1893, ix, p. 141.

- September 3. Only eight per cent are plutei. Remainder are irregular and evaginated gastrulæ.
3. Squirted violently from one dish to another *before* fertilization.
September 3. Practically all are plutei larger than control.
 4. Shaken twenty-five times briskly *before* fertilization.
September 3. Some disintegrate, but remnant all form plutei still larger than 3.
 5. Eggs dropped one inch into a dish of water *before* fertilization.
September 3. No plutei are formed. Irregular gastrulæ of peculiar shape.
 6. Dropped six inches into water *before* fertilization.
September 3. A few irregular plutei. The rest are gastrulæ.
 7. Dropped three feet into water *before* fertilization.
September 3. Result same as 6.
 8. Shaken briskly just *after* fertilization.
September 3. Some eggs disintegrate. Remnant form large plutei.
 9. Transferred carefully one minute *after* fertilization.
September 3. No plutei formed. All are pointed gastrulæ.
 10. Dropped one inch two minutes *after* fertilization.
September 3. About one per cent are small plutei. Rest are like 9.

The foregoing observations establishing the remarkable consequences of very small mechanical shocks on the development of *Arbacia* support, as already pointed out, the contention of Meltzer concerning the fundamental importance of agitation, or mechanical jarring, in the physiology of protoplasm in general. The many analogies already shown to exist between developmental and other physiological processes enable us to apply with some certainty to other cells the conclusions deduced from the egg cell. The importance of such shock, or of its absence, in considering pathological as well as physiological processes must not be lost sight of. Furthermore, although that shock may, as in the egg-cell, produce at the time no obvious histological change, the effect makes itself manifest in a derangement many cell-generations later.

These observations emphasize the necessity of exercising extreme caution in dealing with the action of chemicals, of drugs, or physical agencies on protoplasm. The observations of last year on the influence of pilocarpine and atropine on development required repetition, since in them the controls were not always transferred. A repetition, however, has confirmed the results already obtained. It may be mentioned that the possibility that the glass of the finger-bowls used in the experiments introduced a source of error, was dismissed

by the use of paraffined glass and Jena beakers, which did not materially change the result. All precautions were taken to guard against the possibility of being misled by polyspermy, controls having been carried out with so few sperm that only a portion of the eggs were fertilized.

The results obtained, together with those on parthenogenesis by mechanical agitation, suggest, as pointed out to us by Meltzer, that the mechanical stimulation produced by the sperm, as it enters the egg, may be a matter of far greater importance in fertilization than hitherto considered. The point of the sperm enters the egg and is then violently moved from side to side by the lashing tail. The changes in the egg protoplasm which arise at this point may be the result of this motion and not of a chemical stimulation by the sperm head, as has been supposed to be the case. Perhaps the failure to extract a fertilizing substance from the sperm may be thus explained.¹

Finally, the effects of mechanical agitation on fertilized and unfertilized eggs demonstrate, we believe, the fact that however various the stimuli may be in influencing protoplasmic activity, they produce their effect by altering the state of the protoplasm. This change in state, which may be a change in the state of aggregation of the colloidal particles in the egg, may be set up in various ways, by temperature changes, by the action of ions, by mechanical shock, by drugs or other organic substances, by the influence of oxygen or by its absence. This change in state, however produced, is followed by definite metabolic and structural changes. For artificial parthenogenesis nothing else is necessary than that this change be produced. I have no doubt that electric currents will suffice also, if properly applied, since in all other cells electricity affords us one of the easiest ways of producing such changes. In other words, we are in accord with Morgan's criticism that it is impossible to assume that the stimulus given by the spermatozoon is of the nature of any of the methods so far found for producing parthenogenesis. It is not that the egg lacks specific ions or specific substances that it does not develop parthenogenetically, but only because in the conditions in which it normally finds itself, it cannot unaided bring about the necessary change in state of its protoplasm sufficiently abruptly to cause its development.

Our observations were made at the Marine Biological Laboratory at Wood's Holl.

¹ GIES: This journal, 1901, vi, p. 53.

FIVE TYPES OF EYE MOVEMENT IN THE HORIZONTAL MERIDIAN PLANE OF THE FIELD OF REGARD.

By RAYMOND DODGE.

[*From the Laboratory of Psychology in Wesleyan University.*]¹

NOTWITHSTANDING the large amount of literature on the movements of the eyes, exact quantitative knowledge of the varieties of movement by which they respond to different external circumstances is comparatively limited. Some few types have indeed found general recognition; but they have been isolated either on anatomical grounds or on account of their relation to special problems. Such, for instance, are the torsion and convergence movements of the eyes. But the list of well-defined varieties is short, and the majority of the eye movements have no better classification than their direction. The well-known, persistent untrustworthiness of introspective data regarding our eye movements, together with the difficulty of harnessing the eyes to physiological registering apparatus, readily accounts for this lack of quantitative differentiation. But the consequent confusion has seriously handicapped more than one study in physiological optics, and has been especially unfortunate where the burden of theoretical importance that the eye movements have been compelled to bear has been greatest: I mean in the theory of the visual perception of space.

The present analysis of the forms of eye movement in the horizontal meridian plane of the field of regard was occasioned by some perplexing optical phenomena, noted during the course of an experimental study of the visual perception of motion. The limitations of available apparatus have necessarily restricted the scope of the investigation; but it seemed to me that enough of general physiological interest had been obtained to warrant its publication as a contribution to the classification of the eye movements.

¹ In the experimental work involved in this paper, the author gratefully acknowledges the faithful help of his former pupil, Mr. J. J. Cogan.

METHODS AND APPARATUS.

Until recently, practically the only source of accurate quantitative data concerning the eye movements has been some use of the after-image. Some of these after-image methods have been surprisingly satisfactory. They have given us all that we know of the eye torsion, and of the movement and position of the point of regard during normal vision; and in the hands of Guillery¹ and Brückner² modifications of the well-known Lamansky method have given unexpectedly good results in measuring the angle velocity of the eye. But valuable as these methods are, they have narrow limitations, both in scope and in accuracy, of which no one has been more sensible than those who have used them.

Among the objective methods of studying the eye movements, the oldest and most fundamental, though at the same time one of the most difficult, is direct observation, either with the naked eye, or by the aid of optical apparatus. Direct observation has discovered most of what we know concerning the involuntary eye movements, as well as the alternation of eye movement and fixation pause in the ordinary use of the eyes. But it can never yield any accurate measurements of their velocity, nor can it follow the longer excursions of the eyes with accuracy.

The first really important contribution to our knowledge of the eye movements by means of direct attachment to the eye was made by E. B. Huey³ at Clark University. With a Dellabarre eye-cup and a delicate registering device, direct kymographic records were obtained, showing the eye movements during reading. At the time of their publication these records gave the most nearly accurate measurements of the relation of reading pause to eye movement; moreover, they gave an unmistakably clear picture of that relation, which, doubtless, more than any other one presentation, has given the recent discoveries in the physiology of the eyes in reading a wide-spread acceptance. Unfortunately, the weight and friction of the registering apparatus, small as it was, seriously interfered with the normal functioning of the eye muscles.

In the *Psychological Review* for March, 1901, in collaboration with

¹ GUILLETTY: *Archiv für die gesammte Physiologie*, 1896, lxxiii, p. 87.

² BRÜCKNER: *Archiv für die gesammte Physiologie*, 1902, xc, p. 73.

³ HUEY: *The American journal of psychology*, 1900, xi, p. 283.

one of my students, Mr. T. S. Cline, I published the details of a method and apparatus designed to record movements of the eyes photographically. The record is a continuous photograph of a line across the eye in its horizontal meridian, taken on a slowly falling photographic plate of extreme sensitiveness. As the eye moves, the

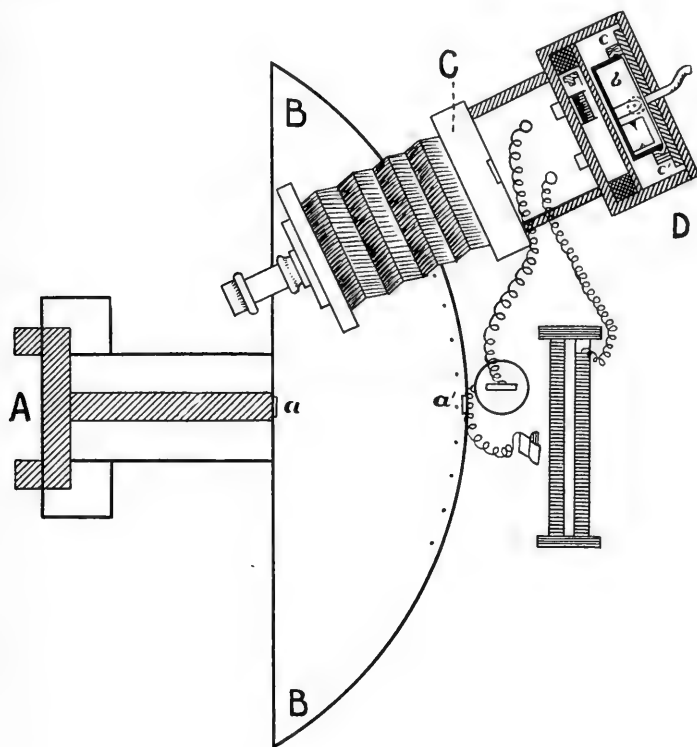

FIGURE 1 is a plan of the apparatus reproduced from the original paper by Dodge and Cline. The camera (*C*) rests on a heavy horizontal perimeter (*BB*), which is fitted with a solid head-rest (*A*), and securely fastened to a heavy table. The arrangement for securing an evenly moving photographic plate is shown in Fig. 1 (*D*), with the top removed; and again, in side elevation, with the side removed, on a larger scale, in Fig. 2.

inequalities of light along that line, corresponding to the transition from sclerotic to iris on either side of the pupil, change their relative position, marking a curve on the negative, corresponding in amplitude and form with the extent and velocity of the eye movement. Since, however, in most eyes the lines of demarcation between the

pigmented and unpigmented parts are not sufficiently well defined to produce negatives that could be read with accuracy, a modification of the above process was instituted, on which rests the method's real claim to accuracy. That modification is to photograph the movements of a sharply defined reflection from the eccentric surface of the cornea. This limits the scope of the method somewhat, in that the arc of eye movement can no longer be determined with accuracy from the records. But in practice the arc of movement is usually a predetermined experimental condition, and the real desideratum is realized: namely, the exact registration of the direction and duration of the eye movements, as well as their relation to the moments of rest.

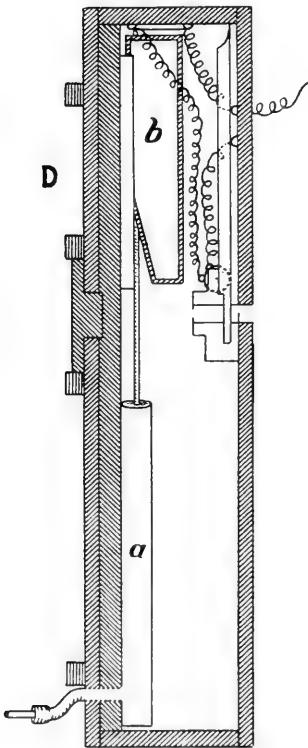

FIGURE 2.

Only one modification of any importance has been made in the apparatus since its formal description. The regulation of the fall of the sensitive plate has been made more exact. Its fall is now controlled by the escape of oil instead of air. In the original apparatus, the plate-holder (*b*) was attached to the rod of a piston playing in a cylindrical air compressor (*d*); the plate could fall only as the air escaped from the cylinder, and the velocity of the fall was regulated by the size of the opening through which the air escaped. Slight oscillations in the velocity of the fall, owing to the elasticity of the air, suggested the use of a fluid resistance. The loss of head which would naturally result as the liquid was forced out of the cylinder, was obviated by leading the vent pipe into the top of the cylinder, and thus returning the oil as fast as it was forced out, maintaining

a constant volume in the cylinder, and rendering the whole device automatic and clean.

This apparatus is probably the most satisfactory method yet devised for recording the movements of the eyes. It operates under normal conditions of binocular vision, is capable of registering both eyes simultaneously, has a unit of measurement less than 1σ , while a ray of light is an ideal registering medium, having neither momentum

nor inertia. Its chief defects are that it is not easily adjusted to other than horizontal eye movements, and that it gives no indication of eye torsion. These limitations have forcibly determined the plane of experimentation, and have compelled me to abstract entirely from torsion movements.

TYPE I.

Those movements of the eye in which the point of regard wanders over any relatively fixed section of the field of vision are doubtless the most numerous, and at the same time the best understood of all the eye movements. In considering the various forms of eye movements in any direction, these would, therefore, naturally constitute the first type.

The most important differentiating characteristic of the first type may be summed up as follows: The duration of eye movements of the first type is less than that of all other movements of the eye. It varies directly with the angle of displacement, but is approximately constant for each individual under the same conditions of fatigue of the eye muscles, of original orientation, and of the direction and angle of eye movement.

If we were dependent on subjective data alone, every one would say without hesitation that he could move his eyes across the field of vision rapidly or slowly at will. This is, however, an illusion. The effort to move the eyes slowly from one point of regard to another always results in one or more complete stops, of which, however, the subject is almost never directly conscious. The simplest method of convincing one's self of this fact is the method of Brown.¹ If the attempt be made to move the eyes slowly along a line which passes through a bright light, on closing the eyes a number of well-defined after-images of the light will be observed, clearly indicating that the eye rested at corresponding points along its path. More satisfactory is the evidence obtained by direct observation of another's eyes. If one is careful not to look directly at the moving eye, but rather at some point on the eyelid, the alternation of movements and stops, as the subject attempts to move his eye slowly, will be clearly distinguished. The kinetograms show that these pauses are of varying length, the shortest being slightly less than 0.2".

¹ BROWN: *Nature*, 1895, lii, p. 184.

It is unnecessary to repeat here a critical résumé of the earlier attempts to measure the duration of the eye movements.

The following table, showing the results of measurements with the kinetograph, is reprinted from the paper by Dodge and Cline, on the angle velocity of the eye movements.

	A.			B.			C.			General average.
	M.	M. V.	No.	M.	M. V.	No.	M.	M. V.	No.	
5° 5-	34.5	1.5	8	29.4	2.9	8	22.4	3.3	10	28.8
10° 5-5	41.8	1.4	9	40.9	3.8	8	33.7	2.1	5	38.8
15° 10-5	46.7	4.5	8	47.9	2.6	10	49.9	3.1	10	48.2
20° 10-10	54.5	8.0	8	51.3	3.5	10	58.6	4.1	10	54.8
30° 15-15	84.3	8.9	7	74.3	9.3	10	82.5	3.8	10	80.4
40° 20-20	100.4	4.5	7	93.4	7.3	10	106.0	8.0	8	99.9

The table gives the mean duration of the eye movements of three subjects through angles varying from 5°-40°. The column at the extreme left gives the angular lateral displacement of the line of regard, together with an indication of the orientation of the lateral displacement with relation to the primary line of regard. M. signifies the mean value in terms of thousandths of a second; M. V., the mean variation; and No., the number of records from which the mean is reckoned. At the extreme right is given the general average for all three subjects.

The results given in the table indicate that the duration of the movements of any individual eye through a given angle tends to remain constant within the limits of a relatively small variation from the mean. The larger mean variation for the angular movements above 15° is due in part to the differences found to exist between the adductive and abductive movements of the eye.

The table shows further that the duration of eye movement increases in direct ratio with the angle. Taking the general average of all three subjects as a basis for calculation, it would appear that for each 5° added to the amplitude of the eye movement between 5° and 40°, about 10σ is added to the duration of movement. But the apparent implication of a fixed maximum velocity of 10σ for each 5° is

false. The experiments of Guillery and of Brückner, as well as my own experiments by the Lamansky method,¹ all show that the maximum velocity of the eye during movements of large amplitude is greater than the maximum velocity during movements of small amplitude. Unfortunately the general conditions of our experimentation preclude an exact analysis of the record curves. But some of their important characteristics are evident to the most casual observer.

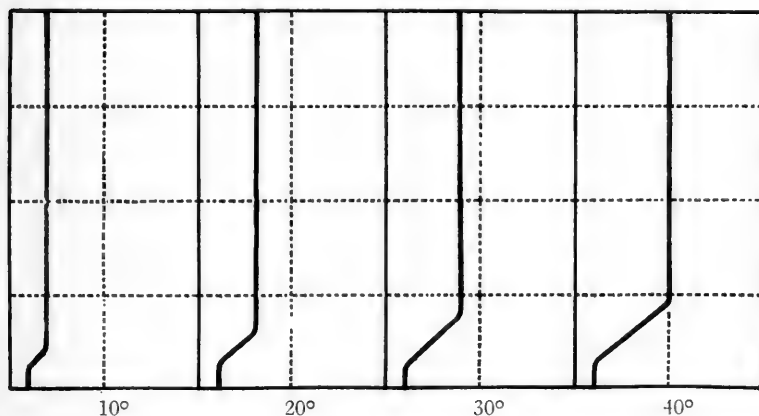

FIGURE 3 is an enlarged drawing from four kinetograms, subject *A*. Each section represents the record of one movement of the right eye, towards the right, through an angle of 10° , 20° , 30° , and 40° , respectively. Each vertical division of the paper corresponds to 125σ ($0.125''$). The vertical height of the oblique lines gives the duration of the eye movement, in each case; while the attached vertical lines represent fragments of the fixation pauses separating the eye movements. The average duration of the fixation pauses partially represented in these drawings was about $0.5''$.

The record of every eye movement, of the first type between 5° and 40° shows three distinct phases. *Cf.* Fig. 3. The first phase consists of a positive acceleration to the maximum velocity; this is maintained for a considerable angle of movement, and constitutes the second phase, giving place in turn to a negative acceleration phase as the eye comes to rest. The relation of these phases is not constant. In the shortest excursions measured, the second phase is very short, while in the longest excursions, with the exception of a peculiar modification in the abductive movements to be described later, the second phase is by far the most conspicuous. Moreover, if one superimpose

¹ ERDMANN and DODGE: *Psychologische Untersuchungen über das Lesen*, Halle, 1898, Anhang, pp. 346-360.

a curve for a movement of 15° on a curve for a movement of 40° , the second phase of the latter record will be found to incline slightly more to the horizontal. This confirms the law that the maximum as well as the average velocity increases in direct ratio with the angle of movement; while, in opposition to the findings of Brückner, the kinetograms indicate that the increase in velocity is confined to the second phase of movement, which in Brückner's experiments could not be dissociated from the first phase.

Guillery observed a decided difference between the velocity of the eye at the beginning and at the end of an eye movement; but his experimental method involved two conditions that tend to distort that relation. In the first place his eye movements were uniformly extreme, and involved considerably more effort and muscle strain than the more natural excursions measured by Dodge and Cline, which never exceeded 20° from the primary position of the eye. Even more important is the fact that I have found it absolutely impossible, even under the most favorable conditions, to secure a series of simple, direct movements of the eyes from one fixation point to another which was more than 40° distant. The distance is persistently underestimated; and the initial long movement of the first type is succeeded by a shorter corrective movement of the same type. Since Guillery's eye movements were all 40° and over, it seems probable that his attempt to measure the velocity of the end of the eye movements was confused by the small corrective movements whose average velocity is comparatively low. In the abductive movements alone, the kinetograms show a marked difference between the velocity of corresponding portions of the first and the third phases. This peculiarity of the third phase is sufficient to account for the longer duration of the abductive movements, as remarked independently both by Guillery, and by Dodge and Cline.¹

The question naturally arises whether the eye movements which occurred under the more or less artificial conditions of our experimentation are of the same kind as those which occur during the unconstrained changes in the line of regard in normal vision. The problem of producing thoroughly unconstrained, horizontal eye movements, under the rather exacting conditions of kinetographic regis-

¹ Brückner finds the relation reversed in his own case. The adductive movements are longer than the abductive. And this leads him to conclude that the differences are mere personal peculiarities, rather than permanent differences of the eye movements in the two directions.

tration, might seem at first rather difficult. But such movements are found in reading. As is now well known, since the researches of Erdmann and Dodge,¹ and of Huey,² the reading of a line of print involves a succession of alternating fixation pauses and eye movements. These vary in number for any one person with the length of line, the print, and the difficulty of the matter read. The complete lack of introspective data regarding this alternation is sufficient sponsor for the lack of constraint. Yet measurements of the eye movements during reading are altogether congruent with the measurements given in Table I.³

The second general characteristic of eye movements of the first type relates to their function in the process of visual perception. Those experiments in physiological optics which depend on the variation in appearance of luminous points and lines during eye movement demonstrate that the normal functions of the retina are not suspended. But the uniformity of the eye movements of Type I, and their relatively short duration as compared with the fixation pauses, naturally raises the question how far normal vision depends upon them. The layman will confidently assert his belief that he can see while his eyes are moving from place to place. Even among physiologists and psychologists it seems to have been taken for granted that we could see during eye movement from one point of regard to another. But wherever found, the belief that we can see the succession of points of regard clearly during eye movements of the first type, is an illusion of introspection. The changes which a luminous point undergoes during eye movement, as shown, for instance, in the Lamansky experiments, are significant. But the matter may be proved by direct experiment. An object placed midway between two arbitrary fixation points, say 30° apart, cannot be seen more clearly during an unbroken eye movement from one fixation point to the other, than it is seen from either fixation point, although the line of regard moves directly through it. Moreover, it can be demonstrated that, under ordinary conditions of illumination by diffused daylight, the object cannot be seen at all, if it is exposed only during eye movement. If a cone of paper with a base sufficiently large to cover the object of regard, and an aperture at the apex the size of the pupil, be

¹ ERDMANN and DODGE: *Psychologische Untersuchungen über das Lesen*. Halle a. d. Saale, 1898.

² HUEY: *American Journal of Psychology*, 1900, xi, pp. 283-302.

³ DODGE and CLINE: *Physiological review*, 1901, viii, p. 153.

placed between the object of regard and the eye, the object will be visible only as long as the pupil stands directly over the aperture in the apex of the cone. If the eye move, as above, through an angle large enough, so that the object will be completely hidden by the sides of the cone at both termini of the movement, it will be found that, unless interruptions occur in the movement, absolutely nothing is seen of the object. If artificial illumination be used in a darkened room, it will be found that the conditions of fusion with a moving retina are approximately the same as the conditions of fusion when the object moves.¹

The problem why, under ordinary circumstances, we do not perceive the fusion of the field of view which should theoretically occur during each eye movement of the first type, has been solved only hypothetically. But the fact that even with careful attention, scarcely a trace of the theoretical fusion of the field of view during eye movements of lesser excursion is perceptible, combined with the fact that during longer movements, say from an extreme inner to an extreme outer position of the eye, some trace of the fusion may be noted, gives a clue to the advantages of rapid movement, uncontrolled by voluntary effort. It would be a serious disturbance to clear vision if the whole field of view melted into an even gray at every eye movement, four or five times a second. And it would be an even more serious disturbance if, with still further voluntary reduction of the velocity, the whole field of view should appear to move about, as the characteristics of the fifth type would indicate.²

The general characteristics of the first type may be summed up as follows :

1. Eye movements of the first type are fundamentally reactions to eccentric retinal stimulation, and are dependent on the tendency, developed during the first month of infancy, to move the eyes so that the point of interest will be seen with the visual centre of the retina.
2. Their velocity is practically uninfluenced by voluntary effort. While their duration shows a slight individual variation under similar circumstances, it varies in direct proportion with the angle of movement.
3. They are primarily not periods of perception, but rather interruptions of vision, whose sole function is to move the line of regard to an eccentric point of interest.

¹ For a more detailed account of these phenomena, see DODGE, Visual perception during eye movement. *Psychological review*, 1900, vii, pp. 454-465.

² See page 328.

Three subtypes appear to conform to the general characteristics of the first type, without being true reactions of the eye to eccentric visual stimuli. These are :

1. Those voluntary and arbitrary movements of the eyes which may occur with the eyelids open or closed, without real reference to any object of interest in the field of vision.

2. The involuntary movements which persist even after all external stimuli have been excluded from the eye.

3. Co-ordinate movements of one eye as the other eye reacts to an eccentric stimulus, unseen by the former.

TYPE II.

Eye movements of the first type, by which we look towards an eccentric object of interest, have been shown to be conditioned by the previous position of the eye, and are involved in each new act of vision only indirectly as a necessary precondition. If we wish to see a moving object, on the contrary, a more or less continuous movement of the eyes will be necessary in order to keep the line of regard congruent with the line of interest. The eye movements in this case are no longer mere episodes, dependent on the previous position of the eyes; they are the moments of fixation, the immediate condition of clear vision, and the direct analogues of the fixation pauses which separate movements of the first type. This modification of the function of the eye movements, as might be expected theoretically, corresponds with a modification of the character of the eye movements, constituting a new type.

We may define this second type as those eye movements in which the line of regard follows an object moving across the field of vision. And the eye movements of the second type may be designated *pursuit movements*. They occur in early infancy, and are so persistent in adult life that even the trained psychologist finds it difficult to keep the eyes fixed in their orbits when the object of regard moves.

An analysis of the conditions under which a pursuit movement may occur shows that every group of pursuit movements must begin as a reaction to eccentric stimulation. Until the object of interest moves, there is no occasion for eye movements; after it moves, however, a measurable time interval must elapse before there can be a muscular response to the perception of motion. The available data concerning the reaction time of the eye indicate that this interval is relatively long.

The first published measurements of the reaction time of the eye were made by the writer in collaboration with Professor Benno Erdmann in 1897.¹ The method used was the blind spot method, but the available apparatus was crude, and the results were published as mere approximations. These experiments indicated that the eye reaction to eccentric visual stimuli involved a reaction interval less than 230σ and more than 180σ for both subjects. In 1899 it was possible for me to measure the reaction of the eye by the same method with apparatus especially designed for the purpose. Both method and apparatus are fully described elsewhere,² and it will be necessary at this time merely to outline their general principle. A primary fixation mark was suddenly superseded by an eccentric mark, towards which the subject was to look immediately on its appearance. The duration of the reaction interval was given directly in the length of time which a bright light must persist, after the stimulus for reaction had been given, in order that it might emerge from the blind spot, on which it rested during the primary fixation, and thus become visible through the reactive movement of the eye itself. The measurements were made on the right eyes of two subjects, and after correction for the slight movement of the eyes, indicated reaction intervals respectively of 170σ and 162σ . In 1900 Huey³ tested the earlier approximations of Erdmann and Dodge by his method of direct attachment, and obtained a corrected mean reaction time for two persons of 171.7σ and 196.9σ , respectively. These results by totally different methods are fairly congruent, and show us clearly that if the first type of movement were the only type, it would never be possible for us to see a moving object clearly. The attempt to follow the moving object would keep the point of regard at least one full reaction interval behind the point of interest; moreover, since the eye movements of the first type effectually prevent clear vision during the movement, the best view we could possibly get of a moving object would be given by the confused, and more or less eccentric image of the moving object while the eye was motionless. That we are not confined to such unsatisfactory conditions of observation is evident from the most obvious data of introspection.

Direct observation of an eye, following a uniformly moving object,

¹ ERDMANN and DODGE: *Psychologische Untersuchungen über das Lesen*, 1898, pp. 116 and following.

² DODGE: *Psychological review*, 1899, vi, pp. 477-483.

³ HUEY: *American journal of psychology*, 1900, xi, pp. 294, 295.

discloses a relatively complex phenomenon, which apparently includes at least two distinct kinds of eye movements. A succession of rapid, jerk-like movements are separated by what appear to be longer regular movements of less velocity. The exact relation of these components, however, cannot be made out by mere observation. In order to adapt the kinetograph to this new problem, a moving object must take the place of the fixation marks. For this purpose we used a continuous belt of white paper about one inch wide, marked with a succession of black crosses. This ran around a polished vertical rod at one side of the table, and around a vertical spool driven by clock work at the other. Screens were then adjusted on the perimeter, to shut off all but twenty degrees of the belt, and the clock work was regulated so that a point on the belt traversed the entire twenty degrees in about one second.

Kinetograms of the eye movements made while the belt was in motion, in the endeavor to follow the cross fixated as long as it was visible, and then to transfer the fixation immediately to another just appearing, show the following details:

1. The attempt to fixate a cross after the signal is given, results, first, in two or three rapid movements of the eye, separated by moments of rest. This first phase of pursuit differs from the kinetograms of reaction movements of the first type, only in the shortening of the fixation pauses.

2. After the first two or three rapid movements there are no further moments of rest during the entire course of a group of measurements, about eighteen seconds. Instead of the moments of rest appear moments of relatively slow eye movement, approximating in angle velocity the movement of the crosses on the belt.

3. Several rapid movements in the direction of pursuit are always found to interrupt each pursuit sweep. These vary from the rapid movements in the opposite direction, which separate the pursuit sweeps, not only in number and amplitude, but also in their apparent function. The latter are usually simple movements of the first type through the entire arc of movement, and indicate the most rapid transition from the end of one pursuit sweep to the beginning of a new one, resembling in every way the return sweep of the eye in reading. The rapid movements in the direction of the pursuit, on the other hand, interrupt each pursuit sweep of twenty degrees from three to six times, three-fourths of such interruptions occurring in the first half of each sweep.

series of rapidly developed habitual responses to a general condition, rather than as individual reactions to specific stimuli, is corroborated by the peculiar action of the eyes of a person who, having watched a moving object for some time, suddenly tries to fixate an unmoved object. In such cases, notwithstanding the absence of any true stimulus for the pursuit movements, and even in opposition to the most strenuous effort to fixate the object at rest, the pursuit movements persist for an appreciable length of time, and give rise to a well-known illusion of motion. The objects which are really at rest seem to move in a direction opposite to that in which the real movement occurred. In experiments with a pendulum in place of the endless belt, the records show that the habitual response may involve considerable variation in velocity in its different phases.

In the traditional accounts of the visual perception of motion, the perception of the eye movements by which the object is followed is always mentioned as an important factor. Without discussing the general question in this place, it may be remarked that since the pursuit movements invariably lag, they alone would give very erroneous data concerning the velocity of the object. Moreover, since they are initiated as reactions, it would seem that the movement of the object must already be apprehended before the pursuit can begin, and that its velocity must have been estimated with considerable accuracy before the pursuit movements could fulfil their function sufficiently well to give any reliable data.

The chief characteristics of the second type of eye movements may be summed up as follows :

1. The velocity of the pursuit movements has no normal value, but varies with the apparent velocity of the object as it moves across the field of vision. The line of regard appears to lag behind the line of interest, and to overtake it, from time to time, by short eye movements of the first type.

2. Unlike movements of the first type, the pursuit movements are moments of clear vision. In fact it is only during pursuit movements that clear vision of a moving object is possible.

3. In further distinction from movements of the first type, which are fundamentally reactions to specific eccentric stimuli, the pursuit movements assume the character of habitual movements, and may persist after the occasion for them has ceased.

4. Finally it is to be noted that, whereas movements of the first type are separated by relatively long periods of rest, movements of the

second type show no periods of rest whatsoever, and must, therefore, involve a more continuous activity of the eye muscles.

A form of eye movement, not objectively different from the pursuit movements, occurs during passive movements of the entire body, as when one rides in a car or is revolved steadily in a chair, while the environment remains stationary. This form, however, is complicated by tendencies to movement which belong to the fourth type.¹

TYPE III.

Similar in some respects to the pursuit movements, yet essentially a new type, are those which we may call after Lotze, *compensatory eye movements*. In order, however, to differentiate them from allied movements of a fourth type, we must designate them *co-ordinate compensatory eye movements*. This third type may be defined as those movements of the eyes by which the constant fixation of an unmoved object of interest is maintained during rotation of the head.

Obviously in every movement of the eyeball which corresponds to the above conditions, there are two distinct factors. The first factor depends on the optical eccentricity of the axis of the head. Since the vertical axis of the head lies behind the eyes, they will be carried with their orbits in the direction of the head movement. Besides the passive movement around the axis of the head, every compensatory movement involves a movement of the eyeball in its orbit. The entire process has sometimes been regarded by those with whom I have spoken, as a mere matter of momentum, by which the eye remained relatively fixed, while the head revolved around it. This conception is, of course, as thoughtless as it is misleading. It would be possible only if the axis of rotation of the eye were identical with that of the head, while the eye hung free in a frictionless orbit. Since neither of these conditions is fulfilled, we must conclude, on theoretical grounds, even if we had no direct experimental proof, that the compensatory eye movements have their direct antecedents in the more or less continuous activity of the orbital muscles.

The quantitative investigation of the third type presents some peculiar difficulties. Since both the head and the eyes move simultaneously, it is obviously impossible to use any of the ordinary head-rests. Without them, however, the probability of securing satisfactory nega-

¹ See page 327.

tives is very small, since a change of one-sixteenth of an inch in the elevation of the head is sufficient to throw the reflection from the cornea out of the exposure slit. In order to offset their loss, a sort of peep sight was used to give the head the right elevation. About half-way between the eye and the constant fixation mark, a fine silk strand was stretched across a concave support, at such a height that its upper edge appeared to touch the fixation mark, when the head was at the required elevation. The chief theoretical objections to this arrangement are two: Interest is divided during the experiment, between the true fixation mark and the thread; and this might easily occasion involuntary changes in the line of regard, which would be overlooked by the subject. The second objection involves the almost inevitable involuntary changes in the elevation of the head. Such changes, after they once occur, must disturb the free movements of the head until they are corrected. On the other hand, this means of preserving the elevation of the head is preferable to any mechanical device attached to the top of the head, since the latter would inevitably modify both the direction and the velocity of the normal fulfilment of a volitional impulse; and this would destroy an essential condition of the experiment. The resulting kinetograms show that the head of the subject never kept within the limits of permissible variation from a constant elevation for more than four or five movements. But even the faulty records are not worthless, since, once understood, their obscurer lines are sufficiently distinct to control the perfect records.

In order sharply to differentiate head lines from eye lines on the kinetograms, a black cardboard square with a heavy white line was fastened to the nose. The eye record was made by the movement of the corneal reflection, as in the previous types.

The chief characteristic of the records is the fact that not once is there a break in the regular compensation of the eye to movements of the head. Nowhere is there discoverable even a hint of an eye movement of the first type, either at the beginning of a series of head movements, or during their progress. This justifies our emphasis on the co-ordinate character of the eye movements of the third type. That they do not begin as reflex movements, like the second type, is shown by the entire absence of the reaction interval, as well as by the absence of secondary corrective movements of the first type. These two characteristics also show that the form of compensatory eye movements under discussion cannot be a response to the afferent impulses from the semi-circular canals, as was proposed by Mach and

Brown. There are, indeed, such responses, but they belong to a different class of compensatory eye movements.

Since there is no control for a primary position of the head, and the angle which the axis of the eye and the nose mark subtend to the centre of the camera lens, varies constantly during the rotation of the head, the important question whether the compensatory eye movements follow variations in the velocity of the head movement accurately or only approximately, is not answered by the kine-tograms. Recourse was consequently had to an experiment of the Lamansky type which serves at once as a demonstration of the most important characteristics of the third type, and an effectual control of the kinetographic records. In a darkened room, a black pasteboard screen, perforated near the centre by a narrow slit made by the thin point of a penknife, was interposed between the eye and a bright gas flame. Directly in front of the screen, a revolving disk was adjusted so that perforations on its periphery exposed the open slit about a hundred times a second. As long as the slit was fixated by the observer, it appeared as a narrow line of light. Whenever the line of regard wandered, the slit appeared to broaden, and if the angle of eye movement exceeded half a degree, it appeared double. If the slit retained its normal shape while it was fixated during head movement, it was conclusive evidence that the eye movement completely compensated for the head movement, not only at the end of the head movement, but also at every moment of that movement. Our experiments showed that compensation is accurate only for head movements of moderate velocity and excursion. When the head moves with extreme velocity, the eye lags. Since it is a well-known fact that the head can move more rapidly than the eye, this insufficiency of the compensating movements under extreme conditions was to be expected, and in no way discounts their general accuracy during moderate head movements. A quantitative determination of the limits of exact ocular compensation to head movements was prevented by the fact that when the head moves back and forth as rapidly as possible, considerable confusion results in the field of view, leading to dizziness and even to nausea. In relation to our specific problems in the visual perception of motion, it is to be noted that as long as the compensatory movements were accurate, the point of light appeared stationary; on the other hand, when the head was moved as rapidly as possible, *i. e.*, under conditions which have been shown to preclude accurate compensation, the point of light appeared to move.

Apart from its relation to the problems of the visual perception of motion, which need not be exploited in this place, this third type seems to me to be of some general physiological interest. In the first place we are compelled to postulate a very complex anatomical basis of co-ordination. This must not only suffice to explain the compensating movements of the eyes when the head rotates, but similar phenomena which I have found to accompany changes in the elevation of the head in walking and running. An instructive instance of a lack of co-ordinate ocular compensation is found if the head remains fixed with relation to the shoulders, while the trunk rotates back and forth on a vertical axis at the hips. The attempt to fixate a given object under these conditions leads to apparent movements of the field of view, and even to dizziness, contrasting sharply with the experience during mere head movements. Furthermore, this delicate preadjustment of the eye movements with head and leg movements, not only with respect to their extent, but also with respect to their velocity, seems to me to represent an important and hitherto unexploited link between tactual space and visual space.

This side of the problem naturally leads to the further question whether the compensatory eye movements are wholly dependent on central co-ordination, or in part also on some control from peripheral stimulation. In all subjects tested, I have found compensatory eye movements to occur whenever the head was rotated voluntarily, even if the eyelids were held tightly closed. These eye movements may be shown to exist in spite of all efforts to prevent them, by direct observation, or by allowing the finger-tips to rest lightly on the closed eyelids as one rotates one's head from side to side. The accuracy of such compensation, however, can be determined only by a special experimental study, for which we have at present no available recording apparatus.

The close relation between the rotation of the head and the compensatory eye movements suggests the question how the head and eyes function together, when both unite in bringing an object of interest into the centre of the field of regard. My own observation may be summed up briefly as follows: The eye never remains fixed in its orbit when the head rotates, unless the point of interest happens to have the same angle velocity as the head, as, for instance, when we fixate the end of the nose. As a rule, when the subject acts naturally and without effort, the eye reacts first to an eccentric point of interest with a movement of the first type, and

the consequent slower movement of the head, to equalize the strain on the eye muscles by keeping the point of regard approximately at the centre of the field of regard, is accompanied by the regular compensatory movements of the eyes. Under the influence of introspection this order may be inverted, but I have never found any one who could hold his eyes fixed in their orbits, during head movements, unless, as mentioned above, the end of the nose or some point moving with the same angle velocity was fixated. Through the kindness of Dr. A. R. Defendorf, Pathologist of the Connecticut State Hospital for the Insane, I have been able to examine the eyes of patients suffering from various forms of insanity, with respect to this peculiarity; and it has appeared to me that some cases of the katatonic form of dementia præcox, as well as cases of dementia paralytica, presented exceptions to the normal compensatory eye movements, which might, perhaps, become of diagnostic value. These abnormalities, however, are to be understood as pathological conditions, and not as exceptions to the general rule. The law of the normal interaction of head and eye is doubtless to be explained in part by the overpowering tendency to compensatory eye movements, and in part by the fact that, for reasons previously explained, the reactive eye movements of the first type are relatively constant in velocity, while the angle velocity of the head movements may be varied voluntarily within wide limits. Casual observation of the relation between the head and eye movements of the lower mammalia shows a decided deviation from the rule observed in man.

The general character of the third type of eye movements naturally suggests the cerebellum as the anatomical centre, and it seems not improbable that we have come upon a physiological explanation of those sagittal fibres of the middle peduncle which appear to connect the cerebellum directly with the nuclei of the third, fourth, and sixth cranial nerves.

The essential characteristics of the third type of eye movements may be summed up as follows: The co-ordinate compensatory movements of the eyes are not reactions to external stimuli. They adjust themselves to all changes in the angle velocity of the head movements, except movements of extreme velocity, immediately, without the elapse of a reaction interval, and without measurable error.

TYPE IV.

A type of compensatory eye movements hitherto undifferentiated from the third type, but really distinct from it both in its origin and in its development, consists of those eye movements which occur in reaction to the organic sensations of passive movement. In contradistinction from the third type, these may be called *reactive compensatory movements*.

If the subject be rotated in a revolving chair, first in one direction, and then in another, while his finger-tips rest lightly on his closed eyelids, he will feel a number of jerky compensatory movements of the eye. These jerks are not reactions to the apparent movement of the environment like Subtype I of Type II, since the eyes are closed: neither can they be due to a co-ordinate efferent impulse like Type III, since the movement is passive. Unfortunately, the essential condition of the phenomena in pure form is that the eyes be closed. This, however, precludes a quantitative investigation by any of the methods at hand. Even their function is obscure, though they probably co-operate with movements of the second type during the rotation of the body on its vertical axis.

According to the observations of Brown and Mach, they cease during a long continued rotation in one direction, and begin again only when the rotation ceases. If this is found to be a general characteristic, their persistence after rotation ceases must be due to entirely different causes from those conditioning the habitual persistence of the simple pursuit movements after the objective occasion ceases.

TYPE V.

The fifth type is in several respects unique. It consists, primarily, of movements of convergence and divergence. Like the first type, it is originally a reaction to eccentric stimulation, but the stimulus falls on disparate points of the two retinæ, and the movements of the two eyes are consequently not in the same but in opposite directions. The most conspicuous of the differentiæ of this type are the relative slowness of the movements, and the fact that, notwithstanding their reactive character, they permit a more or less clear perception of the field of vision during eye movement.

Whereas movements of the first type through 10° occupy about 40σ ; eye movements of the fifth type, of which we have records, occupy about 400σ ; and I have noted movements subjectively that occupied a full second. The physiological grounds of this lessened velocity we have some data for explaining. If two needles are placed, respectively, one and two feet distant from the head, in such positions that when the right eye is at its primary position, both needles lie in its line of regard, it will be found that, in looking from one to the other, the movement of the left eye is of the fifth type, while the right eye, which should theoretically remain stationary, makes jerky little excursions out of the primary position, which it, in turn, afterwards corrects by movements of the fifth type. Kinetographic records of the little abductive jerks show that they correspond in velocity to movements of the first type. We may conjecture that they are occasioned by the same tendency to binocular co-ordination of the eye movements, that normally causes one eye to move in the same direction and approximately through the same angle with the other, when the latter responds to an eccentric stimulus, even though the former eye be closed, or the operative stimulus completely screened from its field of view. It seems not improbable that in all convergence movements of the eyes, each eye is retarded more or less by the tendency to move sympathetically in the same direction with the other eye.

The second characteristic of the fifth type may be observed under almost any condition of convergence as soon as one is attentive to it. It is particularly noticeable when fixation marks, which are approximately in line with the nose, and clearly outlined against a plain white background, are alternately regarded. In each change of the line of regard, the double images of the fixation mark, towards which the lines of regard are moving, may be seen to approach each other, while the single image of the mark previously fixated resolves itself into two, which gradually separate to a maximum distance as the former two coalesce. These phenomena are even more pronounced if the convergence of the eyes is increased or relaxed artificially. The apparent movement of two stereoscopic diagrams which are united without apparatus by voluntary divergence is a familiar example. Similar movements may be noticed when one eye, which has been closed for some time, while the other eye has been functioning normally, corrects its faulty fixation.

Physiologically, this dual perception of the fields of vision moving over each other is interesting as an even more decided case of dis-

parate images from identical retinal points than the well-known Wheatstone phenomenon. Psychologically, it appears as a constant though relatively unexploited datum in the differentiation of the crossed and uncrossed retinal images in the perception of the third dimension.

ON THE QUANTITATIVE DETERMINATION OF AMMONIA IN URINE.

By PHILIP SHAFFER.

[From the Chemical Laboratory of the McLean Hospital for the Insane, Waverley, Mass.]

CONTENTS.

	Page
I. Introduction	330
II. The Schlösing method	331
Conditions governing the Schlösing method	332
The Schlösing method as described in textbooks	333
The Schlösing method as used by previous investigators	335
The alkali used to liberate the ammonia	336
The effect of temperature upon the Schlösing method	338
The Schlösing method as best carried out	338
Tables of results by the Schlösing method	339
III. Vacuum distillation method according to Wurster	342
The modifications by Nencki and Zaleski, and by Söldner	343
IV. The Folin methods	343
V. Vacuum distillation method according to Boussingault	345
VI. The vacuum distillation method as best carried out	348
Tables of results by the new Folin method and by the modified vacuum distillation method	349
VII. Summary	353

I. INTRODUCTION.

WHEN one compares the amount of nitrogen excreted from the body as ammonia, with that excreted as uric acid and the other nitrogenous substances existing in urine in less quantities than urea, and when one considers the large part played by ammonia in metabolism, and the consequent importance of the variations which occur in the amount of this substance excreted under different physiologic and pathologic conditions, it seems strange that the methods proposed for its estimation have not been worked out to a greater degree of efficiency and accuracy. The determination of ammonia has assumed an increased importance in connection with a work on metabolism now being pursued in this laboratory, and it has seemed

advisable to examine critically the better adapted and more generally used methods to determine their accuracy and reliability.

The better known methods are: The Schlösing method for the absorption of the ammonia by acid on standing in a closed vessel, and the several methods by distillation in a vacuum. For one of the latter I shall propose several modifications which make it highly accurate and very satisfactory. The methods based upon the precipitation of the ammonia as a platinum double salt involve, according to Huppert,¹ the error of having an admixture of organic-platinum precipitates, and furthermore are too tedious and expensive for constant use. Such processes were rejected for these reasons.

Two methods by Otto Folin, one of which has not yet been published, have been included in the investigation.

II. THE SCHLÖSING METHOD.

This method was first described in a paper by Schlösing² and was used to determine the ammonia in tobacco. The first application to urine seems to have been made by Neubauer in the first edition of his "Anleitung für Harn Analyse." Neubauer had not at that time made any critical test of the reliability of the method, but in 1855 he published a paper³ stating the details of the process and giving the results of a number of ammonia determinations in normal urines. He stated that the method gave very accurate results.

As used by Neubauer, the Schlösing method was as follows: To 10 c.c. of urine⁴ was added magnesia or milk of lime, and this mixture was placed in a flat dish ten or twelve centimetres wide; over this dish and supported by a triangle was another dish containing the acid; all was enclosed by a tightly fitted bell-jar, and allowed to stand forty-eight hours, at the end of which time, according to both Schlösing and Neubauer, all the ammonia had been liberated and driven off from the liquid by the alkali and absorbed by the acid above. That this

¹ NEUBAUER and VOGEL: *Anleitung zur Analyse des Harns*, 1898, p. 745, ed. 10.

² SCHLÖSING: *Annales de chimie et de physique*, 1851, xxxi, p. 153. This paper contains a cut of the apparatus. The paper was translated in full into the German and again published in the *Journal für praktische Chemie*, 1851, lii, p. 372.

³ NEUBAUER: *Journal für praktische Chemie*, 1855, lxiv, p. 177.

⁴ In a later paper (*Journal für praktische Chemie*, 1855, lxiv, p. 278), NEUBAUER proposed to use 20 c.c. of urine.

is incorrect will be shown below. The authors were led into the error by using standard acid and alkali of such a strength as to make it impossible to measure the small quantities of ammonia given off on standing longer than the first forty-eight hours. Neubauer used to absorb the ammonia, 10 c.c. of sulphuric acid of such a strength as to demand for saturation 225.42 mg. ammonia, or the acid was about 133 per cent normal. The alkali was of such a strength that 1 c.c. was equivalent to 14.7 mg. ammonia, or was almost 87 per cent normal. I have found cases where 10 c.c. urine, under the most favorable conditions for the Schlösing method, gave off more than 0.5 mg. ammonia in addition to that given off during the first forty-eight hours. This would make a difference of 50 mg. per litre, which in many instances would be one-sixth of the total amount in a twenty-four hour quantity of urine. This 0.5 mg. ammonia would be equivalent to only about $\frac{1}{30}$ of a cubic centimetre of the alkali used by Neubauer. Thus may be explained Neubauer's and Schlösing's "complete results after forty-eight hours."

Conditions governing the Schlösing method.—To get even approximate results with this method, it is necessary to fulfil certain conditions, few of which have apparently been considered by any investigator using or describing the method in recent years. Both Schlösing and Neubauer understood the more important of these conditions, and mention them in a general way in their papers, but nowhere else do I find any exact description either of the most suitable apparatus, or of the proper manner of carrying out the operations. In most textbooks, the only method given for the determination of ammonia in urine is the Schlösing method, and with one exception the directions are either too inexact to be of value, or are entirely incorrect. As a result, the method has been used frequently under the most unfavorable conditions, and often has given undoubtedly very erroneous results. In view of the absence of an exact understanding of this method, it seems worth while to discuss it in some detail.

In order to judge of the method's real value, it was first necessary to learn the conditions under which it could be worked most successfully.¹ The Schlösing method depends upon the fact that free ammo-

¹ It was only after learning the difficulties in carrying out the method according to the directions given in textbooks, and when I had already discovered the source of the error as thus worked, that the very general descriptions contained in the papers of SCHLÖSING and NEUBAUER were fully appreciated. SCHLÖSING did

nia is given off from a liquid containing it on being exposed to the air, and that from the air it will be absorbed by an acid. This transfer will take place completely, if carried out in a small closed vessel for a sufficient length of time. *The time necessary for all the ammonia to be given off from a liquid and absorbed by acid depends on the depth of the liquid.* The following experiment with urine will illustrate this fact. The urine and milk of lime was let stand for seven days in a small desiccator (6.7 cm. diameter) containing a titrated amount of acid. At the end of the time, the acid in each was titrated, and the ammonia calculated for one litre of urine. In the first was 50 c.c. urine + 5 c.c. milk of lime; and in the second, 10 c.c. urine + 3 c.c. milk of lime.

Volume of liquid.	Depth of liquid.	NH ₃ in litre.
55 c.c.	16 mm.	581 mg.
13 c.c.	4 mm.	714 mg.

From the fact illustrated in this experiment I have concluded that the layer of liquid should not be deeper than 2 mm. This would allow the use of about 25 c.c. of solution in a dish 12 cm. in diameter. Schlösing used 35 c.c. in a dish of this size. This consideration of the depth of the liquid is not mentioned in books describing the method, and has been disregarded by all recent investigators, as is shown by the fact that where they do give any of the details of their manner of carrying out the method, they state the amount of urine used, but say nothing of the diameter of the dish containing it.

The Schlösing method as described in textbooks :

Huppert¹ directs one to use 25 c.c. urine + 10 c.c. milk of lime, but does not mention the size of dish or bell-jar. He suggests the use of "acid dishes" to contain the urine. These are as a rule about 10 cm. in diameter, making the layer of liquid about 5 mm. deep. He lets the urine stand in the apparatus from three to four days, and claims that in that time almost all the ammonia will be given off.

indeed have an accurate understanding of these conditions, but NEUBAUER placed so little emphasis upon them in the application of the method to urine that it is not surprising that the points have escaped the attention of succeeding investigators.

¹ NEUBAUER and VOGEL: *Anleitung zur Analyse des Harns*, 1898, 10th ed., p. 742.

Salkowski¹ uses a crystallizing dish to hold the liquid containing the ammonia. To 25 c.c. of filtered urine² he adds the same volume of milk of lime, places the mixture under a bell-jar with $\frac{1}{4}$ or $\frac{1}{10}$ acid,³ and lets it stand two or three days. Salkowski likewise does not mention the size of the apparatus.

Hopkins⁴ directs one to use 25 c.c. urine + 20 c.c. milk of lime in a "basin with vertical sides" and to let stand three days, when all the ammonia will be absorbed by the acid.

Halliburton⁵ advises the use of 20 c.c. urine + 10 c.c. milk of lime placed in a beaker and covered with a bell-jar. In forty-eight hours, according to this author, all the ammonia will be driven off and absorbed by the acid. Halliburton makes a further direction which is, to say the least, surprising. He proposes to make a control determination by letting the same amount of urine stand in a similar apparatus, without lime, his idea being to subtract the amount of ammonia formed by putrefaction from that obtained in the first estimation. Without a preservative, a bacterial decomposition will take place in urine, and even after forty-eight hours in many cases, an ammoniacal odor will be noticeable, and the urine will be alkaline.

¹ SALKOWSKI: Practicum der physiologischen und pathologischen Chemie, 1900, 2d ed., p. 252.

² In most cases it will be found advisable to filter the urine from the pus, etc., which is usually present, thus lessening the tendency toward decomposition. Most authors describing the method prescribe the use of filtered urine.

³ The idea seems to exist that the rate of absorption of the ammonia depends upon the strength of the acid. This is probably the reason why the earlier workers used such unusually strong solutions for the purpose. In a recent paper by NENCKI and ZALESKI (*Zeitschrift für physiologie Chemie*, 1901, xxxiii, p. 203), they state that in using their own method (discussed later), with urine an acid stronger than $\frac{1}{10}$ is necessary. This idea is not correct. So long as the acid remains in moderate excess, it will absorb the ammonia as rapidly as it is liberated from the liquid containing it. The following determinations were carried out under identical conditions in an ammonium chloride solution. The volume of the liquid was in each case 30 c.c., and the time seventy-four hours. The results are given in c.c. $\frac{1}{10}$ NH_3 .

Amount of acid used,	With MgO.	With Ca(OH)_2 .
10 c.c. $\text{H}_2\text{SO}_4 = 78.07$ c.c. $\frac{1}{10}$	22.97	25.27
35 c.c. $\frac{1}{10}$ H_2SO_4	25.7	25.5

⁴ HOPKINS: "The chemistry of the urine," in SCHÄFER'S Textbook of Physiology, 1900, i, p. 586.

⁵ HALLIBURTON: Chemical physiology and pathology, 1891, p. 806.

Where this occurs, the ammonia formed from the decomposition of the urea will obviously first tend to neutralize the acidity of the urine, and the excess will be given off. It is this excess only which would be contained in the correction. It has furthermore been shown that the addition of milk of lime prevents the bacterial decomposition which would otherwise occur.¹

Fresenius² gives the correct description of the Schlösing method as proposed in its author's original communication. Fresenius used 35 c.c. or less of liquid in a flat dish 10 cm. to 12 cm. in diameter, and let it stand under a bell-jar forty-eight hours, when he tested the completeness of the expulsion of the ammonia and of its absorption by introducing into the jar a moistened strip of red litmus paper. If the paper changed in color, the apparatus was allowed to stand longer. Even before Neubauer had used the method, Fresenius had quoted this principle direct from Schlösing's paper, in an early edition of his "Quantitative Analyse." His early description has probably not been altered, thus explaining its correctness. Evidently this author has not been consulted on this point by writers of books describing methods for urine analysis.

The Schlösing method as used by previous investigators.—For the reason that they have given no consideration to this condition of the depth of the layer of liquid, it is impossible to form any correct estimate of the accuracy of the results of the many workers who have used this method.³ They worked little if any with ammonium salt solutions of known content, and had no reliable method to use as a check upon their experiments.

Bohland proposed a modification of the Schlösing method, in first creating a vacuum in the bell-jar, thus hastening the expulsion of the ammonia, so that he claimed it complete in forty-eight hours.

¹ SALKOWSKI: *VIRCHOW'S Archiv*, 1873, lviii, p. 486, and *Centralblatt für die medicinischen Wissenschaften*, 1880, xxxviii, p. 690; SALOMEN: *VIRCHOW'S Archiv*, 1884, xcvi, p. 150; HALLERVORDEN: *Archiv für experimentelle Pathologie und Pharmakologie*, 1880, xii, p. 237; NEUBAUER originally proposed this correction in his paper, *Journal für praktische Chemie*, lxiv, p. 278, but its error was recognized and pointed out by the authors quoted above. It seems remarkable to find such a procedure prescribed in a book so recent as HALLIBURTON'S.

² FRESENIUS: *Quantitative Analysis*, 1899, p. 220.

³ MUNK: *VIRCHOW'S Archiv*, 1877, lxix, p. 365; HALLERVORDEN: *Archiv für experimentelle Pathologie und Pharmakologie*, 1880, xii, p. 237; BOHLAND: *Archiv für die gesammte Physiologie*, 1891, xlvi, p. 32; CAMERER: *Zeitschrift für Biologie*, 1899, xxxviii, p. 237.

Hammarsten¹ states that correct results can be obtained with the Schlösing method only with this modification. My own experience has been that although the vacuum does materially aid the expulsion of the ammonia, this advantage is more than offset by the difficulty in keeping the vacuum. Obviously the vacuum must not be made again after the alkali has been added to the urine.

Camerer quotes a series of determinations according to Schlösing by himself, and a series in the same urines according to the same method by Söldner. The figures compare very poorly, and make an excellent example of the untrustworthiness of results by this method as ordinarily carried out. The average difference between the published results of these workers (in the same urines) is 10 mg. in 100 c.c. or fully one-seventh of the total amount.

Camerer got higher results in nearly every case and in less time, and concluded that the reason was that he used a smaller apparatus than Söldner. During the present work it has been learned from experiment that the size of the bell-jar has no effect upon the absorption of the ammonia.

The alkali used to liberate the ammonia in the Schlösing method.—

The alkali used to liberate the ammonia from its salts determines to some extent the rate of its expulsion from a liquid, presumably in that on it depends its solubility. Munk² used sodium hydrate, but this on standing decomposes some substance in the urine and gives too high results. Milk of lime or magnesia has been most commonly used for the purpose. By magnesia the ammonia is given off very slowly, and, according to Söldner, not completely on account of the formation of ammonium-magnesium phosphate crystals.³ Milk of lime gives off the ammonia more rapidly, but causes decomposition on long standing, especially in pathological urines.⁴

The following results⁵ show the rapidity of the expulsion by lime as compared with magnesia. The determinations were carried out under the same conditions, the only difference being in the alkali used. The figures show also the high results with lime and the incomplete results with magnesia. The temperature was about 24°

¹ HAMMARSTEN: *Lehrbuch der physiologischen Chemie*, 1899, p. 482.

² MUNK: *Loc. cit.*

³ See CAMERER: *Loc. cit.* Some of my own results with magnesia have been too low after standing four hundred and fifty-six hours, or nineteen days.

⁴ HALLERVORDEN: *Loc. cit.*

⁵ Each experiment and result quoted in this paper has been chosen as representing a fair average of a large number of similar operations.

C. Sodium carbonate prevents putrefaction in urines as does lime (see page 335).

50 c.c. urine contained 39 mg. NH ₃ .		
50 c.c. urine.	With MgO.	With Ca(OH) ₂ .
48 hours	22.95 mg.	38.25 mg.
96 hours	32.3 mg.	40.8 mg.
144 hours	35.7 mg.	41.3 mg.

Where absolute figures are given in this paper, they have been obtained by one or both of the accurate methods described below (pages 344 and 348).

In my experiments I have used sodium carbonate with greater success than with either lime or magnesia. It drives off the ammonia much more rapidly than does magnesia, and does not cause decomposition as does lime. In order to test this point, some experiments were performed with a 4 per cent solution of peptone which was free from ammonia and contained chloroform as a preservative. In 25 c.c. of this solution standing forty-eight hours at 35° C.,

- Lime gave off 4.5 gm. NH₃,
- Magnesia gave off 0.6 mg. NH₃,
- Sodium carbonate gave off 0.85 mg. NH₃.

At 20° C., the decomposition was somewhat less in each case, but bore the same relation, the decomposition from lime being much greater than from either magnesia or sodium carbonate. The following shows the relative speed with which the ammonia is given off by sodium carbonate, and again indicates the decomposition by lime :

50 c.c. urine contained 19.72 mg. NH ₃ .		
Time.	With Ca(OH) ₂ .	With Na ₂ CO ₃ . ¹
48 hours	19.89 mg.	19.04 mg.
96 hours	21.08 mg.	19.72 mg.

¹ About 0.5 gm. to 1 gm. dry Na₂CO₃ for each 25 c.c. urine.

Between the lowest and the highest of these figures there is a difference of 2.04 mg. which would amount to 40.8 mg. per litre. With none of the generally used methods for determining ammonia could a greater constant correspondence be obtained, and such results have accordingly been considered satisfactory. By the use of methods which will be described further on, a degree of accuracy within *5 mg. to 10 mg. in the litre* is attained without difficulty.

The effect of temperature upon the Schlössing method.— Temperature also has a great influence upon the rapidity with which the ammonia is driven off. Its effect is shown by the following experiment. Four determinations in urine were carried out under the most favorable conditions, but at different temperatures. The alkali used was 0.5 gram dry sodium carbonate for each 25 c.c. urine. The results are given in milligrams of ammonia for 50 c.c. urine.

50 c.c. of the urine contained 19.89 mg. NH ₃ .				
Time.	12° C.	16° C.	25° C.	38° C.
48 hours	16.41	17.17	18.2	19.72
108 hours	19.13	18.96	19.04	21.17
156 hours ¹	18.96	19.38	22.02 ²

¹ In the residues standing at 12° C. and at 16° C., there was found 0.51 mg. NH₃. This, added to the amount absorbed by the acid, will scarcely equal the correct result. The slight difference was probably lost in opening the apparatus at the end of each period to titrate the acid.

² A decomposition is to be observed with Na₂CO₃ at 38° C. even in normal urines.

At 12° and 16° C. we see from the figures above how slowly it comes off. At such temperatures the expulsion is probably not complete even after a week. I have tried letting the desiccators stand in an incubator at 38° C., and with some success, but at this temperature, even with magnesia, there is a slight decomposition which renders the results too inaccurate for scientific work.

The Schlössing method as best carried out.— The most accurate results with the Schlössing method may be obtained as follows. To filtered urine add sodium carbonate and let stand with $\frac{1}{10}$ acid in a desiccator or under a tightly fitting bell-jar. With 25 c.c. urine, about

half gram sodium carbonate, and an excess of sodium chloride,¹ standing in a dish from 15 cm. to 17 cm. in diameter, at 20° C. or higher, the expulsion of the ammonia will be almost complete in three to four days. The length of the operations may be reduced to forty-eight hours by letting the apparatus stand at 38° C. On longer standing at such a temperature the ammonia from decomposition becomes considerable,² and even after the first forty-eight hours the results are not always reliable. When a smaller dish is used to hold the urine, a correspondingly smaller amount must be used, the best conditions being, as has already been mentioned, to have the depth of the liquid not more than 2 mm. For the same amount of urine *the wider the dish the more rapid will be the expulsion of the ammonia.*

In order that the liquid may cover the entire surface of the dish, and that the layer may not be thicker in some parts than in others, the dish should have a flat bottom. Crystallizing dishes or the bottom of large desiccators are adapted to the purpose. The Schlösing method as thus described may be considered satisfactory in many respects for clinical purposes; but it can of course be used only where one can wait two days or longer for the results. The uncertainty of the method, however, renders it quite unsuitable for more accurate work.

Tables of results by Schlösing method. — The following tables contain results of determinations in urines according to the Schlösing method. The conditions of the operations are stated in each case, except that the depth of the liquid has always been about 2 mm. The ammonia has been determined also by one or both of the accurate methods described further on, and it is the average of these results which is given as "ammonia actually present." The results contained in the tables represent the greatest accuracy that may be obtained with the Schlösing method.

¹ Enough sodium chloride to make a saturated solution prevents to some extent any decomposition which may otherwise take place, presumably by lessening the amount of dissociation of the alkali.

² In each case a few drops of chloroform have been added to prevent bacterial growth.

Urine No. 1. Normal.

				Gm. NH ₃ per litre.	Difference. Mg.
....	Ammonia actually present			0.489	
50 c.c. urine.	38° C.	96 hours	MgO	0.473	-16
50 c.c. "	38° C.	27 days	"	0.516	+27
50 c.c. "	22° C.	192 hours	"	0.481	- 8
20 c.c. "	38° C.	96 "	"	0.503	+14
20 c.c. "	22° C.	144 "	"	0.490	- 9
10 c.c. "	22° C.	144 "	"	0.459	-30
25 c.c. "	38° C.	56 "	Ca(OH) ₂	0.527	+38
25 c.c. "	38° C.	24 "	"	0.489	0
25 c.c. "	22° C.	100 "	"	0.506	+17
25 c.c. "	22° C.	56 "	"	0.486	- 3
10 c.c. "	38° C.	55 "	"	0.535	+46
10 c.c. "	38° C.	43 "	"	0.467	22
10 c.c. "	22° C.	110 "	"	0.498	- 1
10 c.c. "	22° C.	84 "	"	0.476	-13
10 c.c. "	22° C.	43 "	"	0.467	22
5 c.c. "	22° C.	84 "	"	0.484	- 5

Urine No. 2. Normal.

....	Ammonia actually present			0.374	
10 c.c. urine	38° C.	48 hours	Na ₂ CO ₃	0.374	0
25 c.c. "	22° C.	120 "	"	0.361	13
25 c.c. "	22° C.	100 "	"	0.361	13
10 c.c. "	38° C.	48 "	Ca(OH) ₂	0.391	+17
10 c.c. "	22° C.	100 "	"	0.391	+17
10 c.c. "	38° C.	48 "	MgO	0.382	- 8
10 c.c. "	22° C.	156 "	"	0.362	12

Urine No. 3. Normal.					
		Gm. NH_3 per litre.	Difference. Mg.		
....	Ammonia actually present . . .	0.742			
25 c.c. urine	22° C. 117 hours MgO	0.727	-15		
	After standing 117 hours the ammonia remaining in the liquid was determined according to Folin (page 344). This amount added to that above gave . . .	0.741			
Urine No. 4. Normal.					
....	Ammonia actually present . . .	0.328			
25 c.c. urine	22° C. 117 hours MgO	0.234	-94		
	After standing 117 hours the ammonia remaining in the liquid was determined according to Folin (page 344). This amount added to that above gave . . .	0.326	- 2		
Urine No. 5. Normal.					
....	Ammonia actually present . . .	0.398			
25 c.c. urine	38° C. 48 hours Na_2CO_3	0.394	- 4		
25 c.c. "	38° C. 156 " "	0.440	+42		
25 c.c. "	25° C. 156 " "	0.387	- 7		
Urine No. 6. Normal.					
....	Ammonia actually present . . .	0.394			
25 c.c. urine	22° C. 96 hours $\text{Ca}(\text{OH})_2$	0.421	+27		
25 c.c. "	22° C. 96 " Na_2CO_3	0.394	0		
Urine No. 7. Contained large quantity of blood.					
....	Ammonia actually present . . .	0.393			
25 c.c. urine	22° C. 134 hours $\text{Ca}(\text{OH})_2$	0.462	+69		

III. VACUUM DISTILLATION METHOD ACCORDING TO WURSTER.

In 1887 Wurster¹ proposed what is generally considered the original method for determining ammonia by distillation in a vacuum at low temperatures. He proposed to distil at about 15 mm. pressure, and 50° C., 5, 10, or 20 c.c. urine with baryta water, magnesia, or lime, and claimed the operation complete after five, ten, or fifteen minutes, depending upon the amount of urine used. The use of such small quantities of urine for the determination greatly lessens the accuracy of the method by multiplying any existing error.

The ammonia is not completely given off under these conditions in the short time named by Wurster, as the following will show :

20 c.c. of urine was distilled in a round bottom litre flask with 15 c.c. of a cold saturated solution of barium hydrate² at 15 mm. pressure and 50° C. After fifteen minutes from the beginning of the boiling, the operation was stopped and the acid titrated. The distillation was then continued for two similar periods.

15 minutes	gave per litre	2.057 gm. NH ₃
30	“ “ “ “	2.082 gm. NH ₃
45	“ “ “ “	2.088 gm. NH ₃

These results would have been considered satisfactory by Wurster, but a higher degree of accuracy has been desired in the present work, and it is with such a standard in view that the methods are criticised.

The greatest objection to the method, as used by Wurster, is, however, the practical difficulty. His apparatus was bulky and of an inconvenient arrangement. A troublesome foaming which always occurs with either of the alkalis used by Wurster frequently ruins the operation, — by the foam getting into the acid, — necessitating many repetitions. Both magnesia and lime cause more foaming than does baryta.

To avoid this Wurster and others³ used different arrangements of

¹ WURSTER: *Centralblatt für Physiologie*, 1887, i, p. 485; also *Berichte der deutschen chemischen Gesellschaft*, 1889, p. 1903; see the BOUSSINGAULT method, p. 345.

² With both lime and magnesia the operation is still less complete in the same time.

³ NENCKI und ZALESKI: *Archiv für experimentelle Pathologie und Pharmakologie*, 1895, xxxvi, p. 385; SCHWARTZ: *Wiener medicinische Wochenschrift*, 1898, iii, p. 98; SÖLDNER: In a paper by CAMERER: *Zeitschrift für Biologie*, 1899, xxxviii, p. 236.

flasks, etc., intended to catch the foam, which complicate the apparatus and rarely accomplish the purpose.

The modifications by Nencki and Zaleski, and by Soldner. — Nencki and Zaleski modified the method of Wurster by heating slowly to 35° C., and then distilling at this temperature for three hours or longer. Correct results may be obtained with this modification, but the unusual length of the operation, and the complexity of the apparatus, do not recommend it for general use.¹ Söldner distils in a partial vacuum (about 15 mm.) at 50° C., but renders the apparatus still more bulky by introducing two extra Woulf's flasks and a Liebig condenser. The condenser is used both to lessen the foaming and to prevent the boiling of the acid. With a properly arranged wash bottle, to contain the acid, its boiling will cause no trouble, and such a contrivance is not necessary. To absorb the ammonia completely, a much more effective arrangement is that of two wash bottles shown in figure, page 348.

Söldner uses 50 c.c. urine + 10 c.c. milk of lime² and distils off about one-fifth of the liquid. The time will vary from thirty to sixty minutes. During such a time a slight decomposition sometimes takes place, as may readily be shown by continuing the distillation for a second sixty minutes with new acid.

IV. THE FOLIN METHODS.

Folin³ described a method based upon the distillation of the urine with magnesia in two periods of the same length. The difference between the ammonia received during the second period (which was formed by the decomposition of the urea) and the total obtained during the first period was thought to be the preformed ammonia. On continuing the distillation for four or more successive periods of forty-five minutes each, the amount of ammonia given off in each period after the first was, if worked carefully, remarkably constant. The results by this method were repeatedly lower than those accord-

¹ Each determination takes about four hours. This method has been used largely for determining ammonia in blood.

Two parallel determinations in dog's urine by these authors have a difference of 88 mg. ammonia per litre. The method can, however, be worked more accurately than this would indicate.

² As stated on page 336, SÖLDNER claims that with magnesia the results are always low.

³ FOLIN: *Zeitschrift für physiologische Chemie*, 1901, xxxii, p. 515.

ing to Schlösing however, and by working with known artificial mixtures of urea and ammonia were found to be in every case too low by as much as 5 mg. for the amount of solution used (25 c.c. or 50 c.c.), or as much as 200 mg. per litre. This is explained by the fact that on boiling an aqueous solution of urea, no point can be reached, so long as undecomposed urea remains, at which the boiling liquid will not contain a considerable amount of ammonia,¹ whereas before boiling the liquid is free from ammonia. Consequently the amount of ammonia given off from the liquid is less, by the amount retained, than that actually formed. Likewise on boiling urine with an alkali, all of the ammonia formed from decomposition of the urea during the first period is not given off. The preformed ammonia is of course all given off during the first period.

At the beginning of the second and following periods the liquid will contain its maximum of ammonia from the decomposition, and consequently all formed during these periods will be given off. The error being dependent upon the amount of urea in solution was not constant in different urines, and so destroyed the usefulness of the method. This I reported to Dr. Folin and in conjunction with him tested it further and arrived at the above conclusion as to its cause.

Later Dr. Folin devised a method for the determination of ammonia in other animal fluids, as well as in urine, which he will shortly describe in detail in Hoppe-Seyler's *Zeitschrift für physiologische Chemie*. The reliability of this method for urines is established. It has been used in this work and its results compared with those of the other methods. Tables of results will be found at the close of this paper. The method is carried out as follows:

To 25 c.c. or 50 c.c. urine (or solution of ammonium salt), placed in an areometer cylinder about 45 cm. high and 5 cm. in diameter, is added 1 gram or 2 grams sodium carbonate and 8 grams or 16 grams sodium chloride.² A current of air is driven through the urine, carrying off the ammonia set free by the sodium carbonate, and allowing it to be absorbed by passing through a definite amount of $\frac{N}{10}$ acid, the excess of which is afterward titrated and the ammonia calculated. The length of time necessary for the completion of the

¹ About 2.5 c.c. $\frac{N}{10}$ in 200 c.c. liquid. After reaching about this amount, the ammonia in the solution at any one time will remain practically constant.

² The sodium chloride is added here, as in the SCHLÖSING method, to prevent decomposition. The amount of sodium carbonate and of sodium chloride depends upon the amount of urine used.

operation will depend on the amount of air passing through the liquid, as well as upon the temperature. At from 22° to 25° C., and with an air current of approximately 700 litres per hour, the ammonia will be completely driven off from 25 c.c. of urine in an hour and a quarter, or from 50 c.c. in an hour and a half. With a larger volume of urine, a smaller air current, or lower temperature of the urine, a longer time will be necessary. The requisite time must be learned for each air current. This can easily be done by continuing the operation until in an hour there is no ammonia given off. It is necessary to pass the air through a tuft of absorbent cotton or closely packed glass wool, after it leaves the urine and before it passes through the acid, in order to prevent alkali being mechanically carried over. The air current should be uniform and constant. Folin has used a specially constructed tube for the absorption of the ammonia by the acid. Where this is not done, it will usually be found necessary to pass the air through two successive portions of acid to prevent any loss of ammonia. The application of this method to pathological urines and to dog's urine will be discussed in comparing it with the other accurate method yet to be described.

V. THE VACUUM DISTILLATION METHODS ACCORDING TO BOUSSINGAULT.

Boussingault in 1850 published¹ a paper in which he described a method for determining ammonia in solution of its salts and in urine by distilling to dryness in a vacuum with milk of lime at 40° to 50° C. The distillation lasted in most cases about one hour. Sodium carbonate and bicarbonate were also used in place of lime. The ammonia was absorbed by standard acid and titrated. This is undoubtedly the original application of vacuum distillation to the determination of ammonia; but the paper received little attention and is apparently not known to workers in this line at the present time. Wurster and those who have modified his method have evidently not been aware either of the work of Boussingault or of the criticism it received from Lehman, Neubauer, and Hoppe-Seyler. These

¹ BOUSSINGAULT: *Annales de chimie et de physique*, 1850, xxix, p. 472. Translated and published in the *Journal für praktische Chemie*, 1850, li, p. 281. Also in BOUSSINGAULT: *Mémoires de chimie agricole et de physiologie*, p. 285.

authors passed adverse criticism upon the method, and declared in favor of the less reliable procedure of Schlösing.

The Boussingault method has been carefully examined during this investigation, and it has been concluded that with simple modification, which will be given, very accurate results are obtained. Even as originally described by Boussingault this method is not only superior to the Schlösing method, but is to be preferred to any of the forms of the same method proposed by Wurster, Nencki, or Söldner.

Boussingault claimed that it was necessary to evaporate the liquid to dryness in order that all the ammonia be given off, and quoted an experiment to prove the point. That this is not the fact one can readily see from the manner of carrying out the method given farther on. Boussingault did not mention foaming, but with lime he undoubtedly experienced this trouble. He used sodium carbonate very largely, however, and with this there is no foaming.

Boussingault found no decomposition on distilling urea solutions in a vacuum with either lime, sodium carbonate, or bicarbonate at 50° C., and therefore concluded that there was no decomposition in urine under the same conditions. He records, however, no experiments in which he continued the distillation of urine for a second period to discover any decomposition.

The following experiment confirms the opinion of Boussingault that the expulsion of the ammonia from solutions is complete, and also that there is no decomposition of urea :

50 c.c. of an ammonium chloride solution containing about 25 per cent urea, + 2 gms. sodium carbonate was distilled in a vacuum at 48° to 50° C. for thirty minutes. The ammonia obtained was 29.07 mg. The theoretical ammonia in 50 c.c. of solution was 29.04 mg. 20 c.c. water was then added and the liquid distilled a second thirty minutes at the same temperature.

This distillation gave absolutely no ammonia.

The following experiment, selected from a large number of similar ones, proves the reliability of the method for many normal urines :

50 c.c. urine + 2 gms. Na_2CO_3 .
 1st distillation gave 11 c.c. $\frac{1}{10}$ NH_3 ,
 2d distillation, 70 min. at 50° C., gave 0.

That there is a slight decomposition in some urines, however, I have proved by repeatedly continuing the distillation for a second and third period after the ammonia had been driven off (as in the above experiments). In many cases the second period gives a small amount of ammonia, which remains constant in succeeding periods, thus proving the decomposition continuous. In many pathological urines this will amount to as much as 30 mg. in the litre.¹

To shorten the period of distillation, without using too small amounts of urine, to a point where this slight decomposition might be disregarded, seemed desirable. Lessening the time needed to make an ammonia determination would of course render the method still more valuable. This was done by adding to the urine a quantity of methyl alcohol, thus lowering the boiling point of the mixture so that a yet more rapid ebullition took place, and more of the liquid distilled over, carrying with it all of the ammonia.

The time of the distillation may in this way be reduced to fifteen minutes, and the entire operation may, after some little experience, be completed in less than half an hour. During the fifteen minutes of the actual distillation, the decomposition is so slight that it will rarely amount to more than 3 mg. in a litre. In pathological urines containing large quantities of albumin the error may be somewhat greater, but in such cases the addition of an excess of sodium chloride (enough to form a saturated solution) will prevent the decomposition being more than the amount just stated.

Sodium carbonate is preferable to the other alkalies used, because with it, as has been said, there is no foaming, and the operation may be carried out without difficulty. With sodium carbonate the decomposition is less than with lime, and no greater than with magnesia (see page 337), and the expulsion of the ammonia is as rapid when liberated by sodium carbonate from its salts in solution as it is from a solution of free ammonia. The exact amount of sodium carbonate added is not important. The decomposition from even a large excess is inconsiderable. One gram for 50 c.c. urine is always sufficient, and with this amount the decomposition in fifteen minutes is practically nothing.

¹ As will be seen, this amount is far within the boundaries of error in duplicate analyses by the SCHLÖSING method. (See tables of SCHLÖSING results.)

VI. THE VACUUM-DISTILLATION METHOD AS BEST CARRIED OUT.

The most satisfactory manner of determining ammonia in urine by vacuum distillation is as follows: The arrangement of apparatus is shown in the figure.

To 50 c.c. urine in flask *A* add an excess (15 or 20 grams) of sodium chloride, and about 50 c.c. methyl alcohol. In bottle *B* place 25 or 50 c.c. $\frac{N}{10}$ acid and in *B'*, 10 c.c. $\frac{N}{10}$ acid, diluted in each case with a small amount of water. If too much water is added, there will be danger of loss of acid by jumping over during the violent commotion which is set up in the acid by the rapid passage of the steam. If such a loss should occur, the acid can always be recovered by rinsing

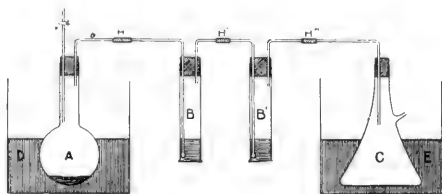

Description of the Apparatus.—*A* is a round bottom litre flask having a two-hole rubber stopper with the two tubes. Tube *a* has a stop-cock to admit air at the end of the operation. This tube does not run below the liquid, as is usual in vacuum distillations, but ends as shown in figure. *B* and *B'* are areometer cylinders with rubber stoppers. They contain the acid to absorb the ammonia. Any wash bottles would answer the purpose. *C* is an ordinary filter flask which is connected with the vacuum pump. In the vessel *D*, surrounding the flask, is water at 50° C., and in *E* is placed ice and water. The cooling is not necessary, however. The glass tubes are connected at *H* with rubber tubing in order that the apparatus may be readily disconnected for titrating the acid.

out the filter flask *C*. When the apparatus is ready, about 1 gram dry sodium carbonate is added to the liquid in flask *A*, the stopper quickly put in place, and the suction started. With a good pump the pressure will be reduced to about 10 mm. in two or three minutes, when, the liquid surrounding *A* being at 50° C., a rapid boiling will begin. The temperature is maintained, and the boiling allowed to continue for fifteen minutes. At the end of that time the ammonia will in all cases have been completely given off, and the operation may be stopped by slowly letting in air at the stop-cock in tube *a*. The acid in *B* and *B'* is titrated and the ammonia calculated.

Alizarin red (1 per cent aqueous solution) has been used as the indicator for the titrations. This substance is not affected by the

presence of ammonium salts, and is very little sensitive to carbonic acid. The end point of the titration is sharp. This indicator is used in this laboratory in all operations where solutions of ammonium salts are titrated.

With this method, as well as in the Folin method already described, the ammonia may be determined with as great accuracy as may any other constituent of the urine. The results are in all cases correct within less than 10 mg. ammonia in the litre.

TABLES OF RESULTS BY THE NEW FOLIN METHOD, AND BY THE MODIFIED VACUUM DISTILLATION METHOD.

Unless otherwise stated, "By vacuum distillation," mentioned in the following tables, means the operation as described on page 348. The amount of urine used for the determinations and the time is mentioned in each case. When the temperature is not mentioned with the results by the Folin method, it was from 22° to 25° C.

Urine No. 8. Normal.				
			Gm. NH ₃ per litre.	Differ- ence. Mg.
By the Folin method	50 c.c. urine	2 hours	0.345	} 8
By vacuum distillation	50 c.c. "	15 min.	0.353	
According to Wurster Ba(OH) ₂	50 c.c. "	30 "	0.361	
Urine No. 9. Normal.				
By the Folin method	25 c.c. urine	2 hours	1.135	} 0
By vacuum distillation	50 c.c. "	15 min.	1.135	
Urine No. 10. Normal.				
By the Folin method	50 c.c. urine	2 hours	0.360	} 10
By vacuum distillation	50 c.c. "	15 min.	0.350	
Urine No. 4. Normal.				
By the Folin method	25 c.c. urine	50 min.	0.323	} 5
Further air blast gave 0.			
By vacuum distillation	50 c.c. urine	15 min.	0.328	
According to Schlösing (see page 341).			0.234	

Urine No. 3. Normal.				Gm. NH ₃ per litre.	Differ- ence. Mg.
By the Folin method	25 c.c. urine	50 min.		0.741	} 2
Further air blast gave 0.				
By vacuum distillation	50 c.c. urine	15 min.		0.743	
According to Schlösing (see page 341).				0.727	
Urine No. 11. Normal.					
By the Folin method	25 c.c. urine	1 hour		0.401	
" "	25 c.c. "	1 "		0.408	
By vacuum distillation	50 c.c. "	15 min.		0.410	
" "	50 c.c. "	15 "		0.407	
" "	50 c.c. "	45 "	38° C.	0.407	
Urine No. 12. Normal horse urine.					
By the Folin method	50 c.c. urine	1½ hour		0.073	} 0
Further air blast, 1½ hours, gave 0.				
By vacuum distillation	50 c.c. urine	15 min.		0.073	
" "	50 c.c. "	15 "		0.073	
Urine No. 1. Normal.					
By the Folin method	25 c.c. urine	10 hours		0.486	
" "	25 c.c. "	11 "		0.496	
" "	25 c.c. "	3 "		0.489	
Next 6 hours' air blast gave 0					
By vacuum distillation	25 c.c. urine	15 min.		0.493	
Next 15 minutes' distillation gave 0.					
By vacuum distillation	25 c.c. urine	30 min.		0.493	
Next 30 minutes' distillation gave 3.4 mg. per litre.					
(See page 340 for Schlosing's results with this urine.)					

Urine No. 2. Normal.				Gm. NH_3 per litre.	Differ- ence. Mg.
By the Folin method	25 c.c. urine	10 hours		0.377	
“ “	50 c.c. “	10 “		0.377	
“ “	25 c.c. “	2½ “		0.374	
By vacuum distillation	25 c.c. “	30 min.		0.374	
“ “	25 c.c. “	15 “		0.377	
Next 60 minutes' distillation gave 6.6. mg. per litre.					
Urine No 13. Fever urine. Much albumin.					
By the Folin method	25 c.c. urine	1½ hours		0.724	} 3
By vacuum distillation	25 c.c. “	15 min.		0.727	
Next 15 minutes' distillation gave 6 mg. per litre.					
Urine No. 14. Fever urine.					
By the Folin method	25 c.c. urine	1¾ hours		0.646	} 17
By vacuum distillation	50 c.c. “	15 min.		0.663	
Same Urine. Later.					
By the Folin method	25 c.c. urine			0.659	} 14
By vacuum distillation	25 c.c. “	15 min.		0.673	
Next 15 minutes' distillation gave 3.4 mg. per litre.					
By vacuum distillation	50 c.c. urine	50 min.	38° C.	0.671	
Next 50 minutes' distillation at 38° C. gave 3.4 mg. per litre.					
Urine No. 15. Contained much blood.					
By the Folin method	25 c.c. urine	1 hour		0.354	} 8
By vacuum distillation	50 c.c. “	15 min.		0.362	

Same Urine. Later. See page 341, Urine No. 7.				Gm. NH ₃ per litre.	Differ- ence. Mg.
By the Folin method	25 c.c. urine	2 hours		0.389	
“ “	50 c.c. “	11 hours at 0° C.		0.393	
By vacuum distillation	50 c.c. “	15 min.		0.389	
Next 15 minutes' distillation gave 3.4 mg. per litre.					
Urine No. 16. Normal dog's urine.					
By the Folin method	20 c.c. urine	2 hours		1.972	} 19
By vacuum distillation	20 c.c. “	15 min.		1.991	
Urine No. 17. Normal dog's urine.					
By the Folin method	50 c.c. urine	1½ hours		1.188	} 46
By vacuum distillation	50 c.c. “	15 min.		1.234	

It will be observed from the tables above that there is in some urines a difference between the results according to the Folin method and those according to the proposed method by vacuum distillation. From a series of experiments it has been concluded that this occasional difference is due to the complete decomposition, under the conditions of the vacuum distillation, of an unstable substance which occurs in some urines in very small quantities. Under the conditions of the Folin method, it is not decomposed, but at a temperature of about 25° C. is driven off with the ammonia, and partially retained in the receiver, as may be shown by heating the acid solution to boiling, or by redistilling the ammonia from the solution. In this way from urines containing this substance more ammonia may be obtained than is shown by the original titration.

That the substance is completely decomposed during the fifteen minutes of the vacuum distillation is proved by the fact that on continuing the distillation for a second period under the same conditions there is either no ammonia obtained or but a trifling amount which could not account for the difference.

Regarding the identity of the unstable substance, I am not able to state. It seems to occur more frequently and in larger amounts in dog's urine than in human urine, in which I have not found it to exceed 20 mg. ammonia in the litre.

The following results from dog's urine are quoted in this connection:

When fresh, about six hours after being voided, the urine contained:

Gm. NH_3 per litre.

By vacuum distillation — 25 c.c. — 15 min. — 50° C.	2.081
According to the Folin method — 25 c.c. — 1 hr. — about 22° C.	2.023
“ “ “ “ “ 25 c.c. — 11 hrs. — about 0° C.	2.026

There can be no doubt of the completion of the expulsion of the ammonia under these conditions. After being treated with the air blast for eleven hours, the urine residue was distilled in a vacuum with methyl alcohol at 50° C. for fifteen minutes. There was obtained 37.4 mg. ammonia per litre. At the low temperature, the urine evidently held a part of the substance, which was then decomposed during the vacuum distillation.

This urine then stood eleven days, when the determinations were repeated. The unstable substance had during this time been decomposed, and the results by the two methods agreed.

Gm. NH_3 per litre.

By vacuum distillation — 25 c.c. — 15 min. — 50° C.	2.091
According to the Folin method — 25 c.c. — 2 hrs. — 22° C.	2.091

In using the vacuum distillation method, it must therefore be considered that it includes in its results the ammonia formed by the decomposition of this unknown substance, which, however, exists not only in such small quantities, but in so few urines as to make the fact of but little consequence.

VII. SUMMARY.

1. The Schlösing method as described in textbooks, and as generally used, is unreliable and its results are usually incorrect. The method depends upon certain conditions which have been entirely disregarded by previous workers. By fulfilling these conditions, results may be obtained which are satisfactory for clinical purposes.

2. The methods by vacuum distillation as described by Wurster, Nencki and Zaleski, and Söldner may give correct results, but, owing to practical difficulties, simpler methods are to be preferred.

3. The method published by Folin in 1901 is inaccurate.

4. The new method by Folin gives accurate and reliable results.

5. The old but unknown method of Boussingault is quite as accurate as the other vacuum distillation methods and less cumbersome.

6. With the use of modifications which are proposed the Boussingault vacuum distillation method is quick and free from difficulty, and its results accurate.

7. For scientific or other careful work the recent Folin method, or the modified vacuum distillation method should be used. With either of these methods a higher degree of accuracy than has yet been attained in ammonia determinations is easily possible.

In conclusion I wish to thank Dr. Otto Folin for his kind counsel during the course of the work.

THE INFLUENCE OF FATIGUE UPON THE SPEED OF VOLUNTARY CONTRACTION OF HUMAN MUSCLE.

BY THOMAS ANDREW STOREY.

[From the *Physiological Laboratory of the University of Michigan.*]

CONTENTS.

	Page
Apparatus and method of work	355
The influence of fatigue upon the speed of contraction	362
Relation between height of contraction and speed of contraction	367
Central and peripheral fatigue	369

SINCE the appearance of Mosso's well-known paper "Ueber die Gesetze der Ermüdung," a very large amount of work has been done by different investigators on the effect of fatigue upon the height of voluntary muscular contractions of short duration. The effect of fatigue upon the speed of voluntary contraction, however, does not seem to have been studied; at least an examination of the literature has failed to discover any papers bearing immediately upon this subject. It is generally admitted that voluntary muscular contractions are tetani, the motor cells of the cord sending impulses to the muscle, according to most of the later observers, at the rate of ten or twelve per second. The cause of the decrease in the height of the voluntary contractions as fatigue comes on is attributed by some writers to fatigue of the muscles themselves, while others believe that it is rather an expression of fatigue of the central nervous system.

The experiments herein reported were undertaken in the hope that they might throw some light upon these points.¹

APPARATUS AND METHOD OF WORK.

The abductor indicis, the first dorsal interosseous muscle, was used throughout this investigation. This muscle has been found by a

¹ This work was done during the spring and summer of 1900.

number of observers, notably Fick and Lombard, to offer many advantages over the flexors of the middle finger employed in the experiments of Mosso, and in many other ergographic studies.

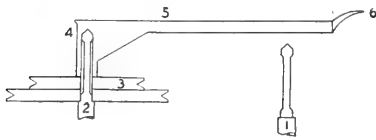

FIGURE 1. — Cross-section of finger-carriage. 1. Steel bearing, fitting into the brass cylinder numbered 4. 2. Steel bearing in place. 3. Pulleys for attachment of various forms of resistance and recording devices. 4. Brass cylinder rotating about the steel axis numbered 2. 5. Support for finger. 6. Horizontal recording point.

The abductor indicis lies close to the surface, is isolated, responds readily to making or breaking induction shocks, and is relatively feeble, and consequently does not require the use of heavy weights or cumbersome apparatus. The hand may be fixed without impairing the freedom of the movement of the finger, and means for obtaining accurate records of that movement can be easily devised.

The ergograph (Figs. 1 to 4) used in this research was a new form devised especially for work with the abductor indicis muscle. It may also be used with the abductor minimi digiti muscle. The essential part of this machine is a device for communicating to a

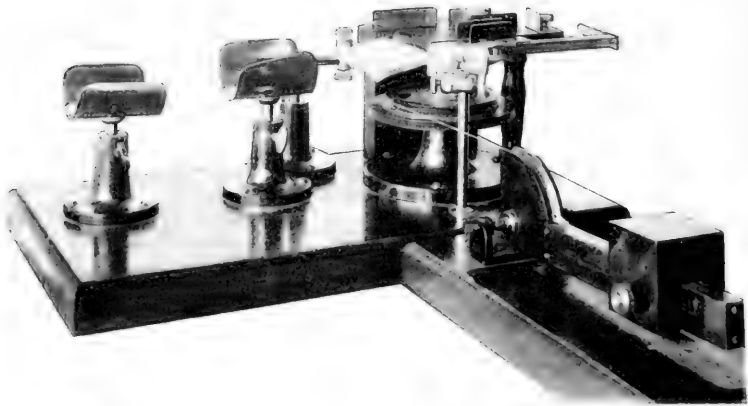

FIGURE 2. — General view of ergograph.

recording point the angular movement of the metacarpo-phalangeal joint when acted upon by the abductor muscle. The recording point is carried at the end of a horizontal arm which supports the finger and rotates about a vertical axis (see Fig. 1). The distal end of the

first phalanx is fastened to the supporting arm by a light brass clamp (see Fig. 2). The vertical axis supporting the horizontal arm is

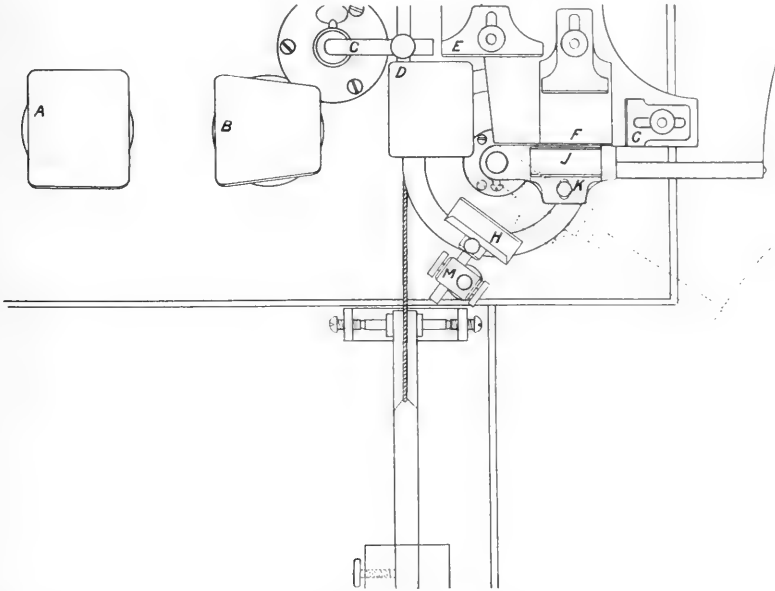

FIGURE 3. — Working drawing of ergograph. Viewed from above. *a* and *b*, arm-rests; *d*, hand-rest and electrode combined; *e*, clamp resting against ulnar side of the hand; *f*, clamp between index and middle finger; *g*, clamp resting against ends of fingers; *h*, clamp holding thumb in place; *j* and *k*, clamps fixing index finger in place over the moving arm below. Dotted lines indicate position of finger-carriage when the muscle is contracted. The spring pointer on the end of the carriage is arranged for tracing the movements made on a horizontal drum.

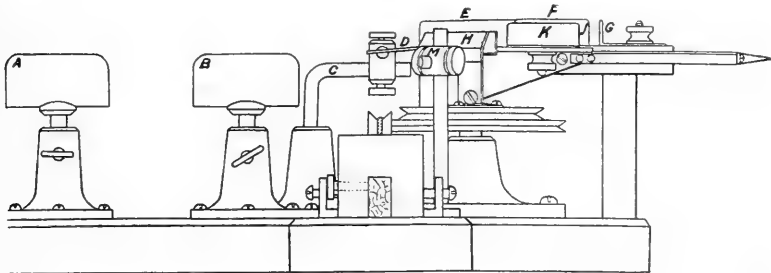

FIGURE 4. — Working drawing of ergograph. Viewed from side. Lettering the same as in Fig. 3.

formed of a brass cylinder with a closely fitting steel core (see Fig. 1). The brass cylinder carries two pulleys (more may be added if needed).

To one of these pulleys is fastened the cord to which the weight is attached. As in the case of an ordinary ergograph this insures constant tension of the finger throughout the movement, and, if the pulley be small, reduces the throw of the weights.

The second pulley is for a thread which connects with a lever or other recording device. This arrangement permits the simultaneous records of the movement on different drums going at different speeds, one record being made by the point at the end of the horizontal arm, and the other by the recording device with which the thread from the second pulley is connected. These pulleys, or additional pulleys, may be used for other purposes. They may connect with various devices arranged to bring tension on the muscle; or they may connect with recording mechanisms, such as Fick's *Arbeitsammler* or Zuntz's *Ergometer*. Of course the size of the pulleys can be chosen to suit the needs of the experiment.

All parts of this ergograph were made as light as possible without sacrificing too much strength and stiffness. The error from the momentum of moving parts was further reduced by the attachment of the weight cord to a small pulley. As far as could be judged, the throw of the lever had little influence in the experiments under consideration. It may be noted here that in the movement of extreme abduction the throw of the horizontal arm was opposed by the elastic web of skin between the bases of the first and second fingers. This influence would in such an event assist in producing relaxation. It would not be present, however, in any but extreme movements of abduction.

With slight modifications of the support for the hand and the base, the ergograph can be turned on its side, and the horizontal arm be then made to write on an upright drum, as in case of the model demonstrated by Professor Lombard at the meeting of the American Physiological Society in Chicago, December, 1901.¹

The weight method (isotonic) was used throughout in these experiments. The isometric method, introduced by Fick, and advocated by Franz, Hough, and Schenck, would be less satisfactory for the purposes of this investigation.²

¹ LOMBARD: *This journal*, 1902, vi, p. xxiv.

² For a discussion of isotonic and isometric methods, see FRANZ: *This journal*, 1900, iv, p. 348; HOUGH: *This journal*, 1901, v, p. 239; TREVES: *Archiv für die gesammte Physiologie*, 1896, lxxviii, p. 45; SCHENCK: *Archiv für die gesammte Physiologie*, 1900, lxxxii, p. 384.

The signal for voluntary contraction was given automatically by a rapidly revolving horizontal drum striking a metal peg against a wooden lever. The lever rested at right angles to the axis of the drum near its bearing. The peg was screwed at right angles into the axis of the drum so that on each revolution it would strike the lever and lift it. The sound of the impact was the signal for contraction. During that portion of the experiment in which the contractions were not to be recorded on the fast drum, an oblong brass plate was interposed between the recording point and the surface of the drum. This in no way interfered with the action of the muscle or with the continuity of the experiment. The brass plate was attached to a wooden rod like a metal flag fixed to its pole. The wooden rod was hinged to the bed of the fast drum. When the rod was in a horizontal position, it was out of service; when it was drawn up to a vertical position, the brass plate on its end came between the writing-point and the drum. The interposition of the brass plate could be accomplished at any time during the experiment.

The time-record was made by the vibration of a tuning fork whose rate was fifty double vibrations a second. The vibrations were traced upon the horizontal drum by means of an electric time-marker or signal. In order that the time-records might not be superimposed at each successive revolution of the drum, the position of this electric time-marker was changed automatically so that the time-record was inscribed as a spiral. This was accomplished by supporting the electric time-marker on a carriage which was driven by a long horizontal screw. The motion of the screw was derived by belts and pulleys from the rotation of the axis of the drum. The same carriage supported a signal which indicated the moment at which the primary current was made and broken in those experiments where the muscle was excited electrically.

The recording point at the end of the horizontal finger-support was a horizontal, flexible phosphor-bronze writing-point (see Fig. 1). The writing-point moved parallel to and level with the axis of the horizontal drum. Its width gave it sufficient strength to be uninfluenced by the movement of the drum.

The lever-arm and writing-point magnified the shortening of the muscle about twenty-five fold. The amount of movement present at the proximal end of the first phalanx during greatest contraction, with no opposition, is about 4 mm.; the amount present in the region of the writing-point under the same conditions is about 100 mm.

(These figures apply to the writer.¹) It might be well to note here that this movement is not one of pure rotation. The metacarpophalangeal joint of the index-finger is a sliding joint.

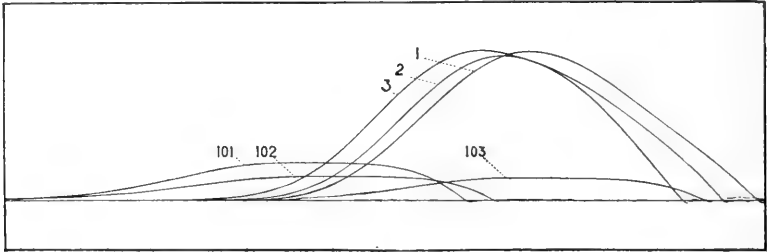

FIGURE 5.—One-half the original size. Curves drawn by the abductor indicis at the beginning and the end of one hundred and three contractions against a weight of about four pounds, and at a rate of about forty-eight a minute.

In working with the electrical stimulus, the make or break shock of the induced current was cut out automatically, by means of two levers

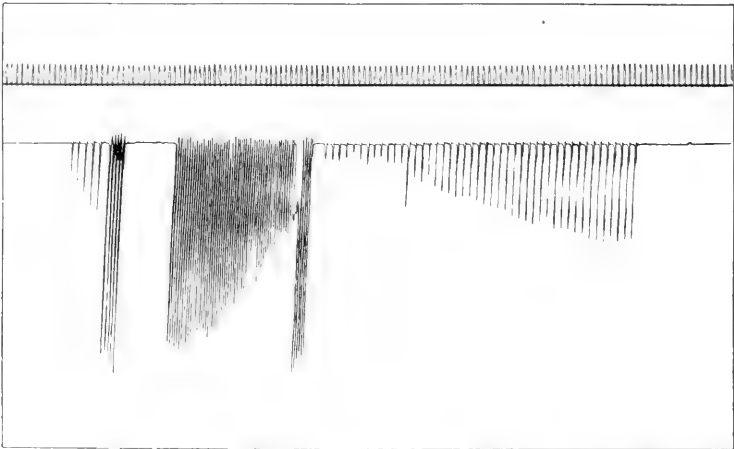

FIGURE 6.—Upper curve marks time in seconds. Lower curve compares voluntarily and electrically stimulated contractions. Weight, unless otherwise indicated, 165 grams. *Course of experiment* (read from left to right). Five electrically stimulated contractions. Five voluntary contractions. Fatigue with voluntary contractions (weight, 1.5 kilograms; rate, two contractions a second). Series of electrically stimulated contractions. Series of voluntary contractions.

like that described above, with the signal for voluntary contraction. The levers were provided with platinum points which dipped into

¹ SCHENCK: *Archiv für die gesammte Physiologie*, 1900, lxxxii, p. 394, finds the same amount of movement at this joint.

mercury cups. They were so arranged that the secondary circuit should be open during either the make or break of the primary. During an experiment, the meniscus in the mercury cup was frequently cleaned with a soft brush to prevent the accumulation of electrolytic products.

In most cases records were made upon the two drums by means of devices described on pages 358 and 370. The rate of one, the upright, drum was slow, giving an ordinary fatigue-tracing. (See Figs. 6 and

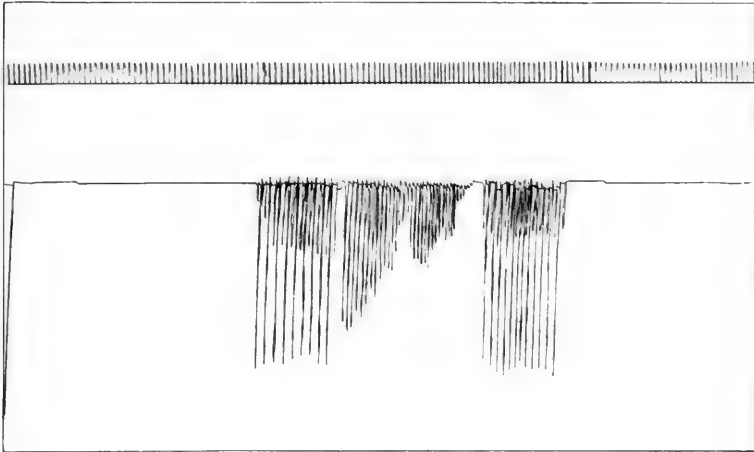

FIGURE 7.—Tracing of alternating electrically and voluntarily stimulated contractions with a 165 grams weight, before and after a series of voluntary contractions made against a weight of 2.7 kilograms, in which the muscle finally is unable to lift the weight.

7.) The rate of the other, the horizontal, drum was rapid, giving myograms and time-records for the study of changes in different phases of each curve (see Fig. 5).

A rapid change of weights was made possible by means of a lever device. Upon referring to Figs. 2, 3, and 4, it will be seen that this device is a lever of the third class, and that it consists of a long arm which supports the weight. There is a hub on the fulcrum-end of the lever over which runs the cord which connects the lever with the weight pulley on the ergograph. When in a horizontal position, the weight lever is put in motion by the movement of the horizontal arm of the ergograph. By sliding the weight along its support, the resistance is changed in amount. By lifting the weight lever to a vertical position, its resistance is taken out entirely.

A platinum point on the hub of the weight lever can be made to dip into a mercury cup when the weight lever is in a vertical position. This mercury key may be used in this manner to close the primary circuit and thus make it possible to change from a voluntary to an electrical stimulation immediately upon taking out the resistance of the weight lever (Figs. 6 and 7).

THE INFLUENCE OF FATIGUE UPON THE SPEED OF VOLUNTARY MUSCULAR CONTRACTION.

The first set of experiments was performed in order to discover the influence of fatigue upon the speed of voluntary muscular contraction. Each experiment consisted of one hundred and three voluntary contractions against a weight of about one and a half kilograms. The rate of contraction was about forty-eight to the minute. At this rate and with this weight, one hundred and three contractions were enough to produce some fatigue. Experiments were made at intervals of several hours. Records of the first and last three contractions in each series were made on the fast drum (Fig. 5). These myograms were then measured. The results are shown in Tables I, II, and III.

An examination of Table I brings out the following facts: —

(1) The height of contraction grows less as fatigue increases. For instance, on the 6th of June at 9 A. M., the highest normal contraction was 58.7 mm., while the highest fatigued contraction was only 22.6 mm.

(2) The duration of the fatigued and lesser movement is sometimes as great as that of the normal and greater movement. This may be seen on comparing the duration of the first contraction with the duration of the one hundred and first contraction at 9 A. M. and at 2.5 P. M. on June 6th.

(3) The duration of the phase of rising energy, or, as it will be called in this paper, "the phase of shortening," after fatigue appears, is ordinarily greater than when the muscle is unfatigued, even though the fatigued shortening is much less in extent. This fact may be noted in every comparison in Table I, except in that made between the third and the one hundred and third contractions at 4.25 P. M. on June 6.

(4) The time required for the phase of relaxation after fatigue is

always less than when the muscle is unfatigued. This is due to the smaller distance through which the finger travels at that stage.

Table II records the speed per second of total contraction, phase of shortening, and phase of relaxation in normal and fatigued voluntary contraction. The figures were carefully compiled and are sufficiently accurate. They show that after the appearance of some fatigue, the speed of contraction is greatly reduced. The reduction varies with the fatigue produced. For example, the most rapid of the first three contractions recorded in Table II was made at the rate of 242 mm. per second, while the most rapid of the last three contractions at the end of that series, was made at the rate of 110 mm. per second.

The question arises, is this reduction in speed confined to some phase of the whole contraction or is it general? Table III furnishes evidence on this point. It appears that there is a reduction in the speed of the total phase of shortening and total phase of relaxation and also of each period of .05 second throughout the entire contraction.

It may be noted that in the normal and fatigued curve, the shortening is at first slow, then faster, then slower as the end of the phase is reached. At the beginning of relaxation, the movement is slow and usually, under the above conditions, gains in speed throughout the rest of its extent. These relations are of course largely due to mechanical conditions.

Summary: — In these experiments fatigue produced: a less extensive contraction; an increase in the time required for the total contraction; a decrease in speed during the phase of shortening; a decrease in speed during the phase of relaxation; a decrease in speed during each five hundredths of a second throughout the phases of shortening and relaxation.

TABLE I.
HEIGHT AND DURATION OF NORMAL AND FATIGUED VOLUNTARY CONTRACTION.

Number of contraction.	Height of contraction in millimetres.		Duration in $\frac{1}{100}$ seconds of total contraction.		Duration in $\frac{1}{100}$ seconds of phase of shortening.		Duration in $\frac{1}{100}$ seconds of phase of relaxation.	
	Normal.	Fatigued.	Normal.	Fatigued.	Normal.	Fatigued.	Normal.	Fatigued.
June 6, 1900 9 A. M.								
1 and 101	54.5	7.3	0.45	0.51	0.26	0.34	0.19	0.17
2 and 102	54.0	22.6	0.50	0.41	0.26	0.28	0.27	0.13
3 and 103	58.7	17.1	0.49	0.46	0.28	0.31	0.21	0.15
June 6, 1900 2.05 P. M.								
1 and 101	63.1	24.2	0.38	0.40	0.23	0.28	0.15	0.12
2 and 102	62.5	27.8	0.45	0.41	0.25	0.29	0.20	0.12
3 and 103	61.7	29.4	0.41	0.37	0.25	0.26	0.16	0.11
June 6, 1900 4.25 P. M.								
1 and 101	59.1	24.5	0.48	0.33	0.25	0.28	0.23	0.12
2 and 102	54.5	17.5	0.44	0.40	0.25	0.27	0.19	0.13
3 and 103	56.1	21.2	0.42	0.39	0.27	0.26	0.15	0.13
June 7, 1900 9.10 A. M.								
1 and 101	65.0	18.0	0.50	0.41	0.26	0.28	0.24	0.13
2 and 102	68.0	14.0	0.48	0.39	0.26	0.27	0.21	0.12
3 and 103	59.0	6.7	0.45	0.45	0.27	0.35	0.18	0.10
June 7, 1900 2.05 P. M.								
1 and 101	64.9	21.9	0.48	0.43	0.25	0.31	0.23	0.12
2 and 102	62.9	15.4	0.45	0.39	0.25	0.26	0.20	0.13
3 and 103	62.1	14.9	0.48	0.43	0.29	0.31	0.19	0.13

TABLE II.

SPEED IN MILLIMETRES PER SECOND OF TOTAL CONTRACTION, PHASE OF SHORTENING AND PHASE OF RELAXATION IN NORMAL AND FATIGUED VOLUNTARY CONTRACTION.

Number of curve.	Total contraction.		Shortening.		Relaxation.	
	Normal.	Fatigued.	Normal.	Fatigued.	Normal.	Fatigued.
June 6, 1900 9 A. M.						
1 and 101	242	28	209	21	287	42
2 and 102	216	110	207	80	200	173
3 and 103	239	74	209	55	279	114
June 6, 1900 2.05 P. M.						
1 and 101	332	121	274	86	420	201
2 and 102	274	135	245	95	312	231
3 and 103	300	158	246	113	385	267
June 6, 1900 4.25 P. M.						
1 and 101	243	148	236	87	256	204
2 and 102	247	87	213	64	294	134
3 and 103	267	108	207	81	374	163
June 7, 1900 9.10 A. M.						
1 and 101	268	87	250	64	271	138
2 and 102	287	71	222	51	320	116
3 and 103	263	29	219	16	329	67
June 7, 1900 2.05 P. M.						
1 and 101	273	103	220	71	282	182
2 and 102	279	70	251	60	314	118
3 and 103	261	70	214	48	335	119

TABLE III.

SPEED IN CONSECUTIVE PERIODS OF FIVE HUNDREDTHS OF A SECOND THROUGHOUT THE VOLUNTARY CONTRACTION OF NORMAL AND FATIGUED MUSCLE.

Periods of 0.05 sec.	Speed in millimetres per second.						
	No. 1.	No. 101.	No. 2.	No. 102.	No. 3.	No. 103.	
June 6, 1900 9.00 A. M.							
1	Shortening.	18	4	36	2	20	4
2		130	10	172	18	100	12
3		348	16	338	86	284	32
4		386	48	356	266	408	104
5		198	46	166	42	306	126
6		..	20	62
1	Relaxation.	94	2	60	46	112	20
2		294	8	156	130	278	86
3		384	60	252	..	330	236
4		242	..	378	..
5		226
June 6, 1900 2.05 P. M.							
1	Shortening.	38	6	18	4	24	10
2		234	34	150	22	158	66
3		464	116	378	90	378	170
4		412	155	474	184	460	212
5		..	160	238	198	214	128
1	Relaxation.	158	66	146	98	158	108
2		472	240	356	300	440	354
3		632	178	386	..	510	..
4		362
June 6, 1900 4.25 P. M.							
1	Shortening.	26	6	26	6	16	6
2		158	28	148	40	114	4
3		354	104	346	94	280	132
4		422	162	382	118	392	154
5		220	144	186	80	294	80
1	Relaxation.	116	58	104	36	142	40
2		308	234	260	126	416	176
3		340	..	390	..	524	..
4		254

TABLE III—*continued.*

Periods of 0.05 sec.	Speed in millimetres per second.						
	No. 1	No. 101.	No. 2.	No. 102.	No. 3.	No. 103.	
June 7, 1900 9.10 A. M.							
1	Shortening.	26	6	26	4	14	2
2		166	24	134	42	114	18
3		352	90	370	56	298	48
4		446	138	492	100	414	50
5		298	94	326	72	300	10
6		4
7		2
1	Relaxation.	128	28	138	22	166	16
2		198	140	282	126	280	118
3		422	..	374	..	442	..
4		290	..	426
June 7, 1900 2.05 P. M.							
1	Shortening.	28	2	24	8	16	4
2		194	8	166	28	122	12
3		418	26	388	114	306	60
4		474	126	446	122	476	116
5		..	166	234	54	316	94
6		..	146	16
1	Relaxation.	140	55	134	20	124	20
2		322	200	326	110	380	134
3		368	..	458	..	456	..
4		326	..	340

RELATION BETWEEN HEIGHT AND SPEED OF CONTRACTION.

In the unfatigued condition the speed of shortening is greater in the higher contractions than in the lower, but there are many exceptions to the rule. In the case of the fatigued contractions this relation between height of contraction and speed of shortening is much closer, as appears in Table IV.

TABLE IV.

THE SPEED OF SHORTENING COMPARED WITH THE HEIGHT OF VOLUNTARY CONTRACTION IN THE NORMAL AND FATIGUED CONDITION.

Normal.		Fatigued.	
Height of contractions in mm.	Speed of shortening in mm. per sec.	Height of contractions in mm.	Speed of shortening in mm. per sec.
54.0	207	6.7	16
56.1	207	7.3	21
54.5	209	14.9	48
58.7	209	14.0	51
54.5	213	17.1	55
62.1	214	15.4	60
59.0	219	17.5	64
64.9	220	18.0	64
68.0	222	21.9	71
59.1	236	22.6	80
62.5	245	21.2	81
61.7	246	24.2	86
65.0	250	24.5	87
62.9	251	27.8	95
63.1	274	29.4	113

The same statements may be made concerning the relation between the height of contractions and the speed in the phase of relaxation (Table V).

TABLE V.

THE SPEED OF RELAXATION COMPARED WITH THE HEIGHT OF VOLUNTARY CONTRACTION IN THE NORMAL AND FATIGUED CONDITION.

Normal muscle.		Fatigued muscle.	
Height of contraction in mm.	Speed of relaxation in mm. per sec.	Height of contraction in mm.	Speed of relaxation in mm. per sec.
54.0	200	7.3	42
59.1	256	6.7	67
65.0	271	17.1	114
58.7	279	14.0	116
64.7	282	15.4	118
54.5	287	14.9	119
54.5	294	17.5	134
62.5	312	18.0	138
62.9	314	21.2	163
68.0	320	22.6	173
59.0	329	21.9	182
62.1	335	24.2	201
56.1	374	24.5	204
61.7	385	27.8	231
63.1	420	29.4	269

Why the height and the speed of contraction should be closely related in the fatigued and should differ widely in the fresh muscle is not clear.

THE HEIGHT AND SPEED OF 'UNWEIGHTED VOLUNTARY CONTRACTIONS MADE BEFORE AND AFTER A SERIES OF WEIGHTED VOLUNTARY CONTRACTIONS PRODUCING FATIGUE.

In these experiments the muscles were made to contract voluntarily six or eight times, with no weight to overcome, except the resistance of the levers and recording apparatus, which was about 185 grams. Each contraction was willed to be one of maximal

velocity and extent. Then the muscle was contracted voluntarily against a weight sufficient to produce exhaustion (*i. e.* inability to work longer with that weight and at that rate). The amount of weight was varied in different experiments. As soon as the muscle was unable to lift the weight, the weight was removed and six or eight voluntary contractions were made under the same conditions as in the first unweighted voluntary contractions. The whole series of contractions was recorded on a slow moving drum by means of a †-shaped device. The horizontal arm was used for a writing-point. The upper vertical arm was suspended by a light rubber band, and the lower vertical arm was connected by means of a thread with the pulley described on page 358. By twisting the rubber band, the writing-point was made to rest against the recording surface.

The voluntary unweighted contractions were recorded also on a fast moving belt of tracing paper which was about twelve feet long. The slow moving drum gave a picture of the whole experiment (Figs. 6 and 7); the fast moving belt gave a picture of the velocity of the movement at the desired time.

A record of a tuning-fork which vibrated one hundred times a second was made on the fast moving tracings; on the slow drum the time-record was in seconds.

An examination of Table VI, in which the results of the above experiments are tabulated, reveals the fact that the unweighted contractions after the weighted series producing fatigue, are in many cases as high as the unweighted contractions produced before fatigue; and that the speed is often as great in one case as the other (see Figs. 6 and 7).

THE HEIGHT AND SPEED OF UNWEIGHTED CONTRACTIONS PRODUCED BY THE MAKE SHOCK OF THE INDUCED CURRENT BEFORE AND AFTER A SERIES OF VOLUNTARY CONTRACTIONS AGAINST A WEIGHT, THE VOLUNTARY CONTRACTIONS BEING CONTINUED UNTIL THE MUSCLE WAS UNABLE TO LIFT THE WEIGHT BECAUSE OF FATIGUE.

In these experiments the electric current was made and broken automatically (page 360). Its strength was tested before and after each experiment and every effort was made to maintain the constancy of the conditions under which the experiment was performed. The current was generated by a series of seven Daniel cells. The induc-

TABLE VI.

THE HEIGHT AND SPEED OF UNWEIGHTED VOLUNTARY CONTRACTIONS MADE BEFORE AND AFTER A SERIES OF WEIGHTED VOLUNTARY CONTRACTIONS PRODUCING FATIGUE.

No. of contractions.	Height of contraction in mm.		Time consumed in $\frac{1}{100}$ seconds.				Velocity in millimetres per second.			
			Shortening.		Relaxation.		Shortening.		Relaxation.	
	Before.	After.	Before.	After.	Before.	After.	Before.	After.	Before.	After.
July 7, 1900 4.30 P. M.										
1	..	77.0	..	0.18	..	0.29	..	432	..	265
2	78.2	79.0	0.16	0.17	0.14	0.16	504	464	558	509
3	77.5	81.0	0.17	0.16	0.15	0.24	469	506	534	344
4	80.0	83.5	0.16	0.16	0.15	0.20	500	509	533	417
5	76.0	80.0	0.17	0.17	0.15	0.20	447	481	524	390
6 ¹										
7	73.0	75.0	0.17	0.18	0.15	0.16	429	407	429	474
8	79.0	79.0	0.17	0.18	0.15	0.18	478	432	503	451
9	79.5	79.0	0.20	0.17	0.16	0.20	397	471	496	405
10	..	79.0	..	0.17	..	0.15	..	455	..	526
July 20, 1900 11.30 A. M.										
1	91.8	77.5	0.14	0.13	0.15	0.20	655	620	633	387
2	91.0	99.0	0.17	0.12	0.14	0.13	543	825	650	761
3	98.0	97.0	0.15	0.14	0.13	0.14	655	687	766	702
4	95.0	94.0	0.16	0.17	0.18	0.17	593	546	542	559
5	104.0	94.0	0.15	0.16	0.18	0.17	693	587	577	552
6	..	98.0	..	0.15	..	0.20	..	671	..	494
July 21, 1900 12 M.										
1	82.0	87.0	0.15	0.19	0.17	0.14	540	457	476	621
2 ¹										
3	85.0	85.0	0.19	0.17	0.18	0.19	453	515	472	447
4	89.5	85.0	0.18	0.21	0.17	0.21	508	414	542	404
5	86.0	87.0	0.18	0.18	0.16	0.21	477	497	537	418
6	91.0	87.5	0.17	0.18	0.19	0.17	560	491	466	530
7	91.0	86.0	0.17	0.17	0.20	0.19	535	521	443	457
8	..	82.0	..	0.19	..	0.16	..	438	..	515

¹ Time record injured.

tion coil was one of 13,000 windings. A record of the whole experiment was made on a slow moving drum, and examples taken from time to time during the experiment on a long belt of tracing paper carried on double drums and moving rapidly. This belt was about twelve feet long. In this way two records were made of each experiment, one showing all its details; the other showing the speed of contraction at different times during the experiment, as in the preceding experiments.

An automatic device registered on the long sheet the time when the muscle was stimulated electrically, thus affording a rough basis for estimating the latent period.

The electrodes were arranged as follows: The anode was a flat brass disc covered with chamois skin moistened with a weak solution of common salt in distilled water. This electrode rested against the palm of the hand. The kathode was about the size of a large thimble and was placed directly upon the abductor muscle. It was held in place by means of a rubber band. Its position was about the same in all experiments, and especial care was taken to prevent any changes during each single experiment.

It will be observed, on looking over the tracings reproduced in this paper, that the make-induced shock was used in most cases where electricity was employed as a stimulus. This was done because the strength of make shock used here appeared to be more efficient than that of the break, not only when used to excite the human abductor indicis muscle, but also when used to excite the excised gastrocnemius of the frog. This fact was noted, but the attempt to find an explanation has been reserved for a later time.

The rhythm of contraction was made constant in the like parts of the same experiment. The variation in rhythm in the different experiments may be detected by referring to the time-records in the tracings given.

Table VII (page 374) demonstrates that the height and speed of the unweighted contractions, produced electrically, are reduced during the period of fatiguing voluntary contractions against the weight. For example, it may be noted in the record of the first contraction before fatigue, and in the record of the first contraction after fatigue, that there was a fall in the amplitude of movement from 52.5 mm. to 37.9 mm.; that the time spent in executing the phase of contraction increased from 0.14 to 0.15 second; and that in the execution of the phase of relaxation there was an increase in time consumed from 0.15

second to 0.18 second. It may be seen further that the speed of contraction recorded in millimetres per second, decreased in the phase of shortening from 388.8 mm. before fatigue to 212.6 mm. after fatigue. The decrease in speed in the phase of relaxation was from 354.7 mm. per second to 210.7 mm. per second.¹

Then, the height of contraction is reduced, and the phases of shortening and relaxation are accomplished at a slower speed.

CENTRAL AND PERIPHERAL FATIGUE.²

A comparison of the conclusions drawn from Tables VI and VII brings out the following facts bearing upon the seat of fatigue in voluntary muscular contraction.

Voluntary stimulation with no weight, before and after voluntary fatigue with a weight, gives no good evidence of fatigue (Table VI). The neuro-muscular machine may be subjected to a set of conditions which seem to exhaust it so that it loses its ability to act in response to the will. But there is apparently enough power left to accomplish under more advantageous conditions a normal amplitude and speed of shortening. Then it would appear that either the central or peripheral mechanisms or both, are fatigued for a given weight, but are still normally active for a lighter weight.

¹ It may be noted in passing that staircase contractions appeared in every series of electrically excited contractions produced in this research (Figs. 6 and 7).

² A reference to the following papers cited will show the diversity of opinion existing concerning the seat of fatigue in voluntary muscular contraction. FÉRÉ: *Journal de l'anatomie et de la physiologie*, 1901, xxxvii, p. 14. FRANZ: *This journal*, 1900, iv, p. 348. HARLEY: *Journal of physiology*, 1894, xvi, p. 97. HOUGH: *This journal*, 1901, v, p. 239. JOTEYKO: *Travaux de l'Institut Solvay*, 1900, iii, p. 47. KRAEPELIN: *Neue Heidelbergsche Jahrbücher*, 1896, vi, 2, p. 222. LOMBARD: *Journal of physiology*, 1893, xiv, p. 97; 1892, xiii, p. 6; *American journal of psychology*, 1890, iii, p. 24. MAGGIORA: *Archives italiennes de biologie*, 1898, xxix, p. 267. MOSSO: *Die Ermüdung*, Leipzig, 1892; *Archiv für Physiologie*, 1890, p. 129; *Archives italiennes de biologie*, 1890, xiii, p. 123. MÜLLER, G. C.: *Zeitschrift für Psychologie und Physiologie der Sinnesorgane*, 1893, iv, p. 122. MÜLLER, R.: *Philosophische Studien*, 1901, xvii, p. 1. OSERETZKOWSKY and KRAEPELIN: *Psychologische Arbeiten*, 1898, iii, p. 587. SCHENCK: *Archiv für die gesammte Physiologie*, 1890, lxxxii, p. 393. TRÈVES: *Archives italiennes de biologie*, 1898, xxx, p. 1. WALLER: *Brain*, 1891, liv, p. 174. WOODWORTH: *The New York University Bulletin of the Medical Sciences*, 1901, i, No. 3, p. 133.

TABLE VII.
 HEIGHT AND SPEED OF UNWEIGHTED CONTRACTIONS UPON ELECTRICAL STIMULATION MADE BEFORE AND AFTER A SERIES OF
 WEIGHTED VOLUNTARY CONTRACTIONS LEADING TO FATIGUE.

	Height of contraction in mm.		Shortening in $\frac{1}{100}$ seconds.		Relaxation in $\frac{1}{100}$ seconds.		Speed of shortening in mm. per second.		Speed of relaxation in mm. per second.	
	Before fatigue.	After fatigue.	Before fatigue.	After fatigue.	Before fatigue.	After fatigue.	Before fatigue.	After fatigue.	Before fatigue.	After fatigue.
July 20, 1901										
1	52.5	37.9	0.14	0.15	0.15	0.18	388.8	212.6	354.7	210.7
2	54.9	40.5	0.14	0.16	0.15	0.17	390.5	315.6	378.6	238.2
3	51.9	36.0	0.14	0.15	0.15	0.17	384.4	240.0	357.9	211.7
4	55.9	35.9	0.14	0.15	0.15	0.20	405.0	247.5	372.6	184.1
5	53.0	40.0	0.13	0.15	0.14	0.18	407.7	266.6	392.4	222.2
6	56.0	..	0.14	..	0.14	..	414.8	..	405.8	..
July 20, 1901										
1	11.9	7.7	0.11	0.25	0.08	0.09	108.1	31.4	148.7	91.7
2	18.3	7.1	0.12	0.18	0.10	0.16	152.5	40.5	183.0	44.6
3	25.4	7.1	0.13	0.11	0.15	0.23	195.3	64.5	175.1	30.8
4	26.8	6.1	0.13	0.11	0.16	0.14	209.3	58.0	169.6	43.1
5	28.5	4.0	0.13	0.09	0.15	0.15	219.2	44.4	190.0	26.6

On the other hand, it has been shown in Table VII that electrical stimulation with no weight, before and after voluntary fatigue with a weight, gives unmistakable evidence of fatigue.

If these experiments are not at fault, one is justified in stating that, under these conditions, peripheral fatigue is apparent and that central fatigue, though possibly present, is not apparent (Figs. 6 and 7).

SUMMARY OF RESULTS.

This paper has reported :—

(1) The invention of a new form of ergograph employing a simple muscle easily excited to contraction by the single-induced shock.

(2) Evidence that fatigue produces a less extensive contraction; an increase in the time required for the total contraction; a decrease in speed during the phase of shortening; a decrease in speed during the phase of relaxation; and a decrease in speed during each five one-hundredth seconds throughout the phases of shortening and relaxation.

(3) In the unfatigued condition the speed of shortening is greater in the higher contractions than in the lower, but there are many exceptions to this rule. This relation is much closer in the fatigued contractions. The same statement may be made concerning the relation between the height of contraction and the speed of relaxation.

(4) Unweighted (voluntary) contractions after a weighted series producing fatigue are in many cases as high as the unweighted (voluntary) contractions produced before fatigue, and the speed is often as great in the one case as in the other.

(5) The height and speed of unweighted contractions produced electrically are reduced during a period of fatiguing voluntary contraction against a weight.

Under the experimental conditions outlined in this paper, peripheral fatigue was apparent, and central fatigue was not apparent.

In conclusion, the writer wishes to express his obligation to Dr. Warren P. Lombard for his generous expenditure of time and advice upon this research.



A PHYSIOLOGICAL STUDY OF NUCLEIC ACID.

BY LAFAYETTE B. MENDEL, FRANK P. UNDERHILL, AND
BENJAMIN WHITE.

[From the Sheffield Laboratory of Physiological Chemistry, Yale University.]

CONTENTS.

	Page
Introductory	377
Problems	382
Chemistry of the nucleic acids	383
Preparation of nucleic acid	384
Physiological action of nucleic acid	386
Earlier experiments	386
Present experiments	389
Effects on blood-pressure	391
Effects on blood-coagulation	391
Effects on lymph-flow	393
Immunity	394
The fate of nucleic acid in the body	395
Intravenous injection	395
Intraperitoneal injection	396
Subcutaneous injection	397
Feeding experiments on animals	398
Rectal feeding	400
Experiments on man	400
Summary	403

INTRODUCTORY.

THE successive changes of opinion regarding the origin and elimination of uric acid in the animal body form an interesting chapter in the history of physiological research. The abandonment of the earlier theory which connected the formation of uric acid directly with the decomposition products of the proteids was due to the failure of experimental proofs. In its place has arisen a series of hypotheses which have stimulated investigators to undertake new lines of research and have given direction to the modern teaching regarding the metabolism of the so-called "nucleins."

So long as ordinary meat diets were used in the experimental studies, it was not difficult to show an apparent relationship between nitrogenous metabolism and uric acid production. This fact led to

the attempt to establish a "normal ratio" between urea and uric acid output in man. But it was soon found that wide variations in this ratio might occur in healthy individuals. Thus with certain diets the uric acid output remained noticeably low despite the normally high excretion of urea. This was particularly evident with dietaries in which milk and vegetable foods predominated. On the other hand the results of the feeding experiments of Weintraud¹ and others with thymus again directed attention to the peculiar significance of the nucleins in the production of uric acid.

Early in the course of his study of the nucleins of cells Kossel² directed attention to the possible genetic relationship between these compounds and the uric acid output. Subsequent investigation has tended to verify this assumption. Stadthagen³ and Gumlich⁴ both failed to obtain any experimental evidence of uric acid production from isolated nuclein derivatives. The former fed nuclein obtained from yeast to a dog; and Gumlich likewise fed 22 grams of nucleic acid prepared from thymus (and containing about 10 per cent of phosphorus) with equally negative results. These experiments have, however, been criticised in respect to the methods employed.⁵ Horbaczewski⁶ was the first to demonstrate that the ingestion of nuclein (obtained from the spleen) gave rise to an increased uric acid elimination in man and in the rabbit; but he did not attribute this increase directly to the ingested nuclein. According to Horbaczewski the formation of uric acid is dependent on the decomposition of leucocytes, the latter thus furnishing the real antecedents of the uric acid. Leucocytosis and cellular decomposition thus become essential conditions for uric acid production; and according to the author, ingested nuclein is efficient mainly because of the digestive leucocytosis to which it gives rise.

Despite the fact that experimental evidence in apparent support of the leucocytosis hypothesis has not been lacking,⁷ it can no longer be regarded as the only tenable one. Demonstration of increased uric

¹ WEINTRAUD: Berliner klinische Wochenschrift, 1895, p. 405; Archiv für Physiologie, 1895, p. 382.

² KOSSEL: Zeitschrift für physiologische Chemie, 1882, vii, p. 19.

³ STADTHAGEN: Archiv für pathologische Anatomie, 1887, cix, p. 390.

⁴ GUMLICH: Zeitschrift für physiologische Chemie, 1893, xviii, p. 508.

⁵ Cf. SCHREIBER: Die Harnsäure, Stuttgart, 1899, p. 80.

⁶ HORBACZEWSKI: Monatshefte für Chemie, 1891, xii, p. 221.

⁷ Cf. for example, KUEHNAU: Zeitschrift für klinische Medizin, 1895, xxviii, p. 534.

acid output unaccompanied by leucocyte changes has repeatedly been afforded in recent years;¹ and reversely, marked leucocytosis may occur quite independent of any change in uric acid excretion. The parallelism between the two factors is by no means constant. Two striking illustrations in support of this statement may suffice. Weintraud² found only a very slight increase in the number of leucocytes in his thymus-feeding experiments, although the excretion of uric acid was unusually large. On the other hand Milroy and Malcolm³ (and likewise Henderson and Edwards⁴) have studied cases of lymphatic leukæmia in which an enormous leucocytosis was unaccompanied by any corresponding increase in uric acid output. An essential relation between the two is not apparent; and furthermore it is not unlikely that at times increase in the number of leucocytes may not be accompanied by any simultaneous destruction of these elements.

It will be seen that an increased production of uric acid from disintegrated leucocytes (as it occurs in some forms of leukæmia and after the use of certain drugs) is in no way precluded.⁵ In this case we may look to the liberated nuclein compounds of these cells or to their decomposition products for the antecedents of the uric acid or other excreted purin compounds. We shall attempt to demonstrate further that similar materials introduced into the organism are subject to analogous metabolic changes. The purin bodies which arise from the nuclein may accordingly be regarded as intermediary products of metabolism. One part of these alloxuric compounds is perhaps excreted as such, while another part is first oxidized further and then eliminated.⁶ A rather extensive literature has already arisen in support of this idea, as the outcome of numerous experiments of varied character. Most of these have been concordant in indicating that the ingestion of nuclein-containing tissues in man

¹ Cf. RICHTER: *Zeitschrift für klinische Medicin*, 1895, xxvii, p. 290; HOPKINS and HOPE: *Journal of physiology*, 1898, xxiii, p. 285; MILROY and MALCOLM: *Ibid.*, 1898, xxiii, p. 217; SCHREIBER: *Die Harnsäure*, 1899; BURIAN and SCHUR: *Archiv für die gesammte Physiologie*, 1900, lxxx, p. 258.

² WEINTRAUD: *Berliner klinische Wochenschrift*, 1895, p. 405.

³ MILROY and MALCOLM: *Journal of physiology*, 1898, xxiii, p. 217; 1899, xxv, p. 105.

⁴ HENDERSON and EDWARDS: *This journal*, 1902, vi, p. xxii.

⁵ Cf. LOEWI: *Archiv für experimentelle Pathologie und Pharmakologie*, 1900, xlv, p. 2, where the literature is reviewed.

⁶ Cf. BURIAN and SCHUR: *Archiv für die gesammte Physiologie*, 1900, lxxx, p. 241.

and animals is followed by an increased output of uric acid and other purin compounds varying in quantity with the relative richness of the tissue in the nuclein precursor.¹ In the course of these earlier investigations it was discovered independently by Minkowski² and by Cohn³ that allantoin may be excreted in the dog as an end-product in the metabolic processes which give rise to uric acid elimination after thymus-feeding. Subsequently Salkowski⁴ obtained allantoin after pancreas-feeding; and Mendel and Brown⁵ demonstrated that allantoin excretion can be brought about in the cat also, after ingestion of pancreas, thymus, or lymphatic glands. In man, allantoin has not been detected under similar conditions.⁶ It has, however, been reported to occur in the urine of pregnant women and of newly born infants; and in view of the unsatisfactory methods available for its separation and identification it is not improbable that traces present have repeatedly escaped detection. The significance of the presence of allantoin in the urine of animals fed on a diet rich in nuclein constituents is more apparent when we recall the older observations of Salkowski⁷ that the feeding of uric acid to dogs is followed by an excretion of allantoin. Since the latter is directly obtainable in the laboratory from uric acid by oxidation, a genetic relationship between the two compounds in the organism is at once suggested. Podushka⁸

¹ Cf. WEINTRAUD: Berliner klinische Wochenschrift, 1895, No. 19, p. 405; KUEHNAU: Zeitschrift für klinische Medizin, 1895, xxviii, p. 561; ROSENFELD and ORGLER: Centralblatt für innere Medizin, 1896, p. 42; HESS and SCHMOLL: Archiv für experimentelle Pathologie und Pharmakologie, 1896, xxxvii, p. 243; UMBER: Zeitschrift für klinische Medizin, 1896, xxix, p. 174; MAYER: Deutsche medicinische Wochenschrift, 1896, p. 186; LUETHJE: Zeitschrift für klinische Medizin, 1897, xxxi, p. 112; WEISS: Zeitschrift für physiologische Chemie, 1899, xxvii, p. 216; HOPKINS and HOPE: Journal of physiology, 1898, xxiii, p. 271; JEROME: *Ibid.*, 1899, xxv, p. 98; TAYLOR: American journal of the medical sciences, 1899, cviii, p. 50; MENDEL and BROWN: This journal, 1900, iii, p. 261; MENDEL and JACKSON: This journal, 1900, iv, p. 163; and others.

² MINKOWSKI: Centralblatt für innere Medizin, 1898, No. 19; Archiv für experimentelle Pathologie und Pharmakologie, 1898, xli, p. 376.

³ COHN: Zeitschrift für physiologische Chemie, 1898, xxv, p. 507.

⁴ SALKOWSKI: Centralblatt für die medicinische Wissenschaften, 1898, p. 929.

⁵ MENDEL and BROWN: This journal, 1900, iii, p. 261.

⁶ COHN: *Loc. cit.*, p. 509; MINKOWSKI: Archiv für experimentelle Pathologie und Pharmakologie, 1898, xli, p. 398; LOEWI: *Ibid.*, 1900, xlv, p. 22.

⁷ SALKOWSKI: Berichte der deutschen chemischen Gesellschaft, 1876, ix, p. 719; Zeitschrift für physiologische Chemie, 1902, xxxv, p. 495.

⁸ PODUSCHKA: Archiv für experimentelle Pathologie und Pharmakologie, 1900, xlv, p. 65.

failed to obtain any allantoin after feeding uric acid; but Salkowski's observations have been verified by Minkowski¹ and, in this laboratory, by Swain;² while Mendel and Brown³ have demonstrated that a similar oxidation may occur in the cat. Finally, it must be added that Minkowski obtained allantoin to the extent of 77 per cent after feeding hypoxanthin to a dog.⁴ Experimental evidence thus indicates that purin bases (and nucleins) may give rise to allantoin as an intermediate product in their oxidation. Ordinarily, where the conditions are favorable, these compounds are, as Swain has suggested, more completely oxidized in the system, and their nitrogen presumably reappears in large part as urea.⁵ This might be represented as the ordinary fate of uric acid, for example, when introduced into the *human* body in such doses as are permissible. Furthermore, allantoin itself may be oxidized almost completely in the body.⁶ In the dog, also, comparable quantities of uric acid may apparently be metabolized beyond the stage where allantoin appears as an end-product. But when larger quantities (per kilo of body weight) are fed, the system is evidently unable to bring about so complete a decomposition of the purin radical; and under these conditions allantoin escapes as an end-product of the change. The difference between man and other animals may thus be due, in part at least, to quantitative variations in the extent of metabolism in the involved organs, such as the liver, in addition to any specific peculiarities of different animals.⁷

The investigations of recent years have thus indicated clearly that the purin (or alloxuric) compounds of the urine owe their origin almost entirely to antecedent purin groups introduced into the body as food or otherwise. A small quantity of purin compounds, largely in the form of uric acid, is excreted even on a "purin-free" diet. This quantity, which Burian and Schur have designated as *endogenous* urinary purin constituents apparently varies somewhat with different

¹ MINKOWSKI: *Loc. cit.*, xli, p. 398 (foot-note 3).

² SWAIN: This journal, 1901, vi, p. 38.

³ MENDEL and BROWN: This journal, 1900, iii, p. 267.

⁴ MINKOWSKI: *Loc. cit.*, p. 404.

⁵ Cf. BURIAN and SCHUR: *Archiv für die gesammte Physiologie*, 1901, lxxxvii, p. 239; SALKOWSKI: *Zeitschrift für physiologische Chemie*, 1902, xxxv, p. 495.

⁶ Cf. MINKOWSKI: *Loc. cit.*, p. 399; PODUSCHKA: *Loc. cit.*, p. 64.

⁷ Cf. BURIAN and SCHUR: *Archiv für die gesammte Physiologie*, 1901, lxxxvii, pp. 261, 335; KAUFMANN and MOHR: *Deutsches Archiv für klinische Medicin*, 1902, lxxiv, p. 141.

individuals, although it tends to remain remarkably constant for the same person, even where extensive changes in the nitrogenous elements of the diet are introduced. In general it varies in man between 0.1 and 0.2 gram of nitrogen per day. This represents the end-products of the metabolism of purin complexes of the body cells, and can be ascertained by estimating the purin compounds (chiefly uric acid) of the urine on a "purin-free" diet of milk, eggs, cheese, potatoes, rice, etc. The additional output of purin derivatives which follows a diet containing the antecedents already referred to earlier, may be termed the *exogenous* portion.

Problems.—What are the immediate antecedents of the *exogenous* purin compounds? What changes do the so-called nucleins undergo in metabolism? Do the nuclein compounds from various sources exhibit similar transformations in the organism; that is, do they possess the same physiological value? These and related questions can at present be answered in part only. It is the purpose of this paper to afford further experimental contributions to the modern theory of purin metabolism. Most investigators have employed glands (*e. g.* thymus) rich in "nucleoproteids" as the nuclein-containing substance. Experiments with isolated "nucleoproteids," "nucleins," "nucleates," or nucleic acids are few in number, and the results are by no means concordant. Still fewer experiments have been tried with the purin derivatives: hypoxanthin, xanthin, guanin, and adenin, obtainable from the above.¹ The failure of Stadthagen² to obtain allantoin after guanin-feeding, and the almost similar result of Minkowski³ with adenin, contrasted strongly with the marked allantoin output which follows ingestion of pancreas or thymus. In view of the fact that the nucleoproteid of the pancreas yields guanin (2-amino-6-oxypurin) almost exclusively as its purin constituent, and that the thymus affords a preponderance of adenin (6-amino-purin) on decomposition, it might be assumed that the amino-purin derivatives are not readily transformed in metabolism, or that the transformation is dependent on a peculiar organic group or complex in which these derivatives exist in the tissue cells. Krueger and Schmid⁴

¹ The valuable contribution of KRUEGER and SCHMID: *Zeitschrift für physiologische Chemie*, 1902, xxxiv, p. 549, on the behavior of the free purin bases, appeared after our experiments were undertaken.

² STADTHAGEN: *Archiv für pathologische Anatomie*, 1887, cix, p. 418.

³ MINKOWSKI: *Loc. cit.*, pp. 401, 406.

⁴ KRUEGER and SCHMID: *Zeitschrift für physiologische Chemie*, 1902, xxxiv, p. 549

have, however, quite recently been able to demonstrate the direct transformation of the four common purin bases: xanthin, hypoxanthin, adenin, and guanin, into uric acid in man.

Chemistry of the nucleic acids.—The preceding remarks with reference to the pancreas and thymus will serve to emphasize the differences which are now recognized to exist in the chemical structure of the nuclein bodies. Whether the various related compounds separated from the tissues occur as actual constituents of the latter, or are merely the product of the manipulations employed, cannot be definitely asserted. Common to all of these products, however, is an acid constituent, the *nucleic acid*, which unites with the proteids to form proteid compounds, the *nucleins* or *nucleoproteids*, the latter designation usually being reserved for those compounds which contain a smaller proportion of the nucleic acid radical. The nucleic acids may also be obtained combined with the protamins and free from ordinary proteids. The careful studies of Osborne¹ have led him to the conclusion "that the true nucleic acids are strong polybasic acids, containing the purin, pyrimidin, and carbohydrate groups, and yield on hydrolysis orthophosphoric acid; that there is at least one other acid which contains the purin and carbohydrate group and also yields orthophosphoric acid, but is a substance of a different order, since it contains glycerin and lacks the pyrimidin group; that there are at least two true nucleic acids,—one containing thymin, the other uracyl; that the ultimate composition of these acids is not yet settled, though the more carefully purified preparations have a similar composition."

Up to the present time the thymus, spleen, pancreas, Arbacia-, salmon-, codfish-, and herring-milt have served as sources for the more carefully investigated nucleic acids. The nucleic acid of the wheat embryo (tritico-nucleic acid) is the only one thus far obtained from the higher orders of plants, although the yeast nucleic acid has been known for some time. We have used the wheat product largely in the present research for several reasons. First, it seemed desirable to compare the physiological behavior of the acid of *vegetable* origin with that of the other nucleic acids. Again, the wheat acid can readily be obtained in sufficient quantity and purity; and finally its chemical composition has probably been ascertained more nearly than that of any other known nucleic acid. A pro-

¹ OSBORNE and HARRIS: Connecticut agricultural experiment station report for 1901, p. 387; cf. also *Zeitschrift für physiologische Chemie*, 1902, xxxvi, p. 85.

visional chemical structure has been assigned to it by Osborne,¹ as follows :

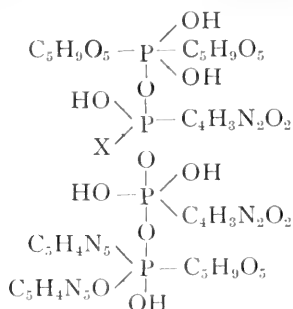

since it yields one molecule of adenin ($\text{C}_5\text{H}_5\text{N}_5$) and of guanin ($\text{C}_5\text{H}_5\text{N}_5\text{O}$), two molecules of uracyl ($\text{C}_4\text{H}_4\text{N}_2\text{O}_2$), and three molecules of a pentose ($\text{C}_5\text{H}_{10}\text{O}_5$). The wheat nucleic acid thus differs from the investigated animal acids in having the pyrimidin group represented by uracyl in place of thymine (methyl uracyl). The pentose derived by Neuberger² from the guanylic acid of the pancreas is xylose. The thymus nucleic acid presumably yields a hexose. The wheat nucleic acid differs from Bang's pancreas guanylic³ acid in containing no glycerin radical. The purest preparations of the nucleic acid of the wheat embryo obtained by Osborne are represented by the formula $\text{C}_{41}\text{H}_{61}\text{N}_{16}\text{P}_4\text{O}_{31}$, with which we have compared our preparations as a standard.

Preparation of nucleic acid. — In preparing nucleic acid compounds from the wheat embryo, the suggestions of Levene⁴ and of Osborne⁵ were applied. The material used was the "yellow germ meal" of commerce, care being taken to obtain a preparation as free as possible from endosperm. The meal consists of small flakes containing the embryo of the wheat kernel flattened into thin scales by the milling processes used. The yield of nucleic acid is variable; and Osborne, who obtained 1.25 per cent, has pointed out that it is

¹ C. OSBORNE and HARRIS: *Zeitschrift für physiologische Chemie*, 1902, xxxvi, p. 120.

² NEUBERGER: *Berichte der deutschen chemischen Gesellschaft*, 1902, xxxv, p. 1467.

³ BANG: *Zeitschrift für physiologische Chemie*, 1901, xxxi, p. 416.

⁴ LEVENE: *Journal of the American chemical society*, 1900, xxii, p. 329.

⁵ OSBORNE and CAMPBELL: *Connecticut agricultural experiment station report for 1899*, p. 305; *Journal of the American chemical society*, 1900, xxii, p. 379.

necessary to use very fresh meal, since the yield decreases after a few weeks. The nucleic acid is present in the embryo in combination with proteids in the form of nucleates (nucleoproteids) from which it must be separated. Our purest preparations (as judged by their freedom from proteid) were obtained as follows:

The wheat germ meal was twice extracted with seven times its weight of water, the supernatant liquids being siphoned off and strained through cloth. The united extracts were then saturated with sodium chloride, hydrochloric acid being added until the precipitate separated out well. The bulky nucleate thus obtained contained a variable but large proportion of proteid as indicated by its low phosphorus content.¹ It was digested for nearly a week with 0.2 per cent hydrochloric acid containing an abundance of very active scale pepsin, with repeated renewal of the digestion medium. The undissolved residue was repeatedly washed by decantation and finally dissolved in water by careful addition of sodium hydroxide. The solution was alkaline to phenolphthalein. Dilute hydrochloric acid was then carefully added until a proteid precipitate began to separate, and this was filtered off. After the usual treatment with water, alcohol, ether, and drying at 100°, it was found to contain 1.15 per cent of phosphorus.² The filtrate was treated with stronger hydrochloric acid which deposited a granular precipitate. The later was treated with water, alcohol, and ether; and dried at 100°, it formed preparation **H**. The analysis was as follows:

Preparation H	Osborne's purest preparation
N . . . 15.07 per cent 15.88 per cent
P . . . 8.43	" 8.70 "

A part of the nucleic acid precipitated by the hydrochloric acid was redissolved in sodium hydroxide, and the solution, after filtration, poured into a large volume of alcohol (95 per cent). The fine cream-white precipitate thus deposited was washed, dehydrated and dried in the usual way. An analysis of this *sodium nucleate*, preparation **K**, gave

P	8.47 per cent
-------------	---------------

¹ Cf. OSBORNE and CAMPBELL: *Loc. cit.*

² The determinations of phosphorus in these compounds were all made by the usual gravimetric process after fusing the substances with pure sodium hydrate and potassium nitrate in a nickel crucible. Nitrogen estimations were made by the KJELDAHL-GUNNING method.

Another preparation, **M**, consisting of 31 grams obtained from about 20 kilos of meal, gave the following analysis :

P	7.35 per cent
N	16.34 “

and was accordingly not quite as pure as the preceding products.

Other preparations (nucleates) still containing some proteid in combination with the nucleic acid were also made. The preliminary treatment was the same in each case, the proteid extracted from the meal being subjected to vigorous pepsin-acid digestion to eliminate a portion of the proteid. One residue which was found to contain 3.7 per cent of phosphorus after digestion for several days, was subjected to repeated digestion with pepsin-acid for three days at 38°. This final product, nucleate **C**, now contained

P	4.56 per cent,
-------------	----------------

and, assuming a phosphorus content of 9 per cent in the nucleic acid, was composed of the latter to the extent of about one-half. Another digestion residue, nucleate **D**, gave an analysis of

P	2.9 per cent,
-------------	---------------

indicating a nucleic acid content of about one-third. Finally, one preparation was separated in part by Levene's method. The digestion residue was dissolved in sodium hydroxide and then almost neutralized with acetic acid. Sufficient picric acid solution was then added to make the fluid slightly acid. The proteid-picric precipitate, containing only a trace of phosphorus, was removed by filtration. To the filtrate strong hydrochloric acid was added to precipitate the nucleic acid, and then alcohol to facilitate its separation. The product, **F**, was only about two-thirds nucleic acid, since the analysis indicated

P	6.04 per cent.
-------------	----------------

In addition to these preparations we have used a commercial "yeast nucleic acid" which contained some admixture of proteid.¹

PHYSIOLOGICAL ACTION OF NUCLEIC ACID.

Earlier experiments. — The physiological action of the nucleic acids and their derivatives after direct introduction into the circulation has

¹ This was kindly furnished to us by PARKE, DAVIS and Co., of Detroit. It was reported to contain about 6 per cent of phosphorus.

received little attention up to the present time. Wooldridge¹ discovered some years ago that his so-called "tissue-fibrinogens," prepared from extracts of various organs and injected into the veins of a dog, produced thrombosis of the portal vein and its affluents; and he later ascertained that a degree of "immunity" toward a second injection could be brought about by a previous one.² Wright³ continued these investigations. Halliburton⁴ and his co-workers showed that the various tissue extracts which produce intra-vascular clotting contain nuclealbumins, as indicated by their noticeable content of organic phosphorus and the formation of an insoluble phosphorus-containing residue by artificial gastric digestion. In rabbits a solution of the separated nucleoproteids usually produced death in a short time by respiratory failure. The thrombosis was ordinarily limited to the venous system, the portal vein sometimes being involved. Nucleoproteids prepared from the thymus, kidney, testis, liver, lymphatic glands, brain, and red marrow — containing from 0.4 to 1.4 per cent of phosphorus — all showed this property. It was discovered that albino rabbits and the Arctic hare in its albino stage are immune to these effects.⁵ Lilienfeld⁶ found that his "nucleohiston," prepared from leucocytes, likewise gave rise to intravascular clotting, and he concluded that the tendency toward production of thrombosis is attributable to the nuclein component of the compound injected. But it must be remembered in this connection that Martin⁷ similarly obtained thrombosis with snake-venom which he found to be free from nucleoproteid; and Halliburton and Pickering⁸ were able to induce intravascular coagulation in various animals by injection of Grimaux's proteid-like *colloïde amidobenzoïque* and *colloïde aspartique*, each of which is free from phosphorus and in no way directly related to the nucleoproteids. Five to ten c.c. of 1.5 per cent solutions are fatal, while small doses of both nucleoproteids and the synthesized colloids may retard coagulation. Gioffredi⁹ has found that a nuclein prepared from tubercle bacilli brings about death

¹ WOOLDRIDGE: Archiv für Physiologie, 1886, p. 397.

² WOOLDRIDGE: *Ibid.*, 1888, p. 526.

³ WRIGHT: Journal of physiology, 1891, xii, p. 184.

⁴ HALLIBURTON and BRODIE: Journal of physiology, 1894, xvii, p. 135.

⁵ PICKERING: Journal of physiology, 1896, xx, p. 310.

⁶ LILIENFELD: Zeitschrift für physiologische Chemie, 1894, xx, p. 141.

⁷ MARTIN: Journal of physiology, 1894, xv, p. 380.

⁸ HALLIBURTON and PICKERING: Journal of physiology, 1895, xviii, p. 285.

⁹ GIOFFREDI: Jahresbericht für Thierchemie, 1900, xxx, p. 1028.

speedily in rabbits when it is injected intravenously in doses of 0.02-0.08 grams. In dogs also thrombosis is brought about by this preparation.

The most important recent contribution to this subject is that of Bang,¹ who has studied the physiological action of Hammarsten's pancreas nucleoproteid and the guanylic acid obtained from it. The latter has been extensively investigated from the chemical standpoint by Bang, who obtained as characteristic decomposition products: guanin, a pentose, glycerin, and phosphoric acid. It will thus be seen to differ essentially from the wheat nucleic acid used by us. The phenomena observed by Bang, after intravenous injection of pancreas guanylic acid into dogs, were characteristic, resembling in many ways the effects produced by protamin injections² and by larger doses of proteoses.³ The quantities injected varied from 0.02 to 0.06 grams per kilo of body weight. In every case the injection immediately provoked a state of excitation in the animal, followed by transitory narcosis. The clotting of blood withdrawn from the vessels was greatly delayed, a dose of 0.04 grams per kilo prolonging the clotting time from the normal of six minutes to two hours. With 0.018 gram per kilo the delay was only from a clotting time of ten minutes (before the injection) to nineteen minutes. The effects on respiration were also pronounced. Blood-pressure quickly fell after the injection, the pulse-waves of the records becoming smaller, while the heart-beat gradually became more forcible with a return of normal pressure. The fate of the injected guanylic acid was not ascertained. It was noted, however, that the urine always became distinctly alkaline after the injection, and albuminuria was observed. The results of the injection of the β -nucleoproteid of the pancreas were similar in nearly every respect. A dose of 0.05 grams per kilo was sufficient to abolish the coagulability of the blood in dogs completely, or almost so. In rabbits a noticeable retardation in blood-clotting was obtained with 0.14 gram of the pancreas nucleoproteid per kilo. The effect was far less marked than with dogs; and it may be recalled that intravenous injections of proteoses are practically ineffective in the case of the rabbit. In the dog, Bang noted a fall of arterial pressure after injection of the nucleoproteid. The urine did not show an

¹ BANG: *Zeitschrift für physiologische Chemie*, 1900, xxxi, p. 410; 1901, xxxii, p. 201.

² C. J. THOMPSON: *Zeitschrift für physiologische Chemie*, 1899, xxix, p. 1.

³ C. J. CHITTENDEN, MENDEL, and HENDERSON: *This journal*, 1899, ii, p. 142.

alkaline reaction in this case, but contained dextrose (not pentose) in three of the five trials.

Present experiments. — Our experiments on the physiological action of the wheat nucleic acid introduced directly into the circulation were carried out on dogs, cats, and a rabbit. Careful observations were made with reference to the effect on the coagulability of the blood, on blood-pressure, on lymph-flow, on "immunity," and the fate of the injected acid. The dogs were anæsthetized with A. C. E. mixture after receiving a hypodermic injection of 1 cgm. of morphin sulphate and 1 mgm. atropin sulphate per kilo of body weight. The

TABLE SHOWING EFFECTS UPON ARTERIAL PRESSURE.

Experiment.	Weight of dog in kilos.	Grams per kilo injected.	Duration of injection in seconds.	Preparation employed.	Pressure in milligrams of Hg.								
					Just before injection.	Just after injection.	5 min. after.	10 min. after.	20 min. after.	30 min. after.	40 min. after.	50 min. after.	1 hour after.
IX	12.5	0.024	13	H (8.43% P)	126	100	130	130
IV	13.0	0.044	42	H	120	38	70	84			
VIII	12.7	0.05	17	H	126	32	26	68	..	80	106	..	110
VI	17.0	0.105	8	H	94	32	30	..	20	..	42	..	50
VII	8.0	0.15	7	H	140	42	42	85	108				
V	11.0	0.055	28	K (8.47% P)	110	20	12	38	78	84	110		
III ¹	6.5	0.065	90	K	98	108	100	66	64	62	
II	7.0	0.056	58	F (6.04% P)	110	24	40	36	..	30	44	72	76
I ²	..	0.100	19	C (4.56% P)	86	60	24	16	54		

¹ Slow injection.
² In this experiment a rabbit was used.

substances were dissolved as sodium nucleates in a small volume (15-30 c.c.) and injected rapidly, *i. e.*, within a minute, from a burette into the jugular vein. Arterial pressure was recorded with a mercurial manometer in the carotid artery, and the blood samples were collected from a clean cannula introduced into a femoral vein, the coagulation time being noted as in previous experiments in the



FIGURE 1.—Experiment IX. Dog of 12.5 kilos. Preparation H. Injection of 0.024 gm. per kilo.

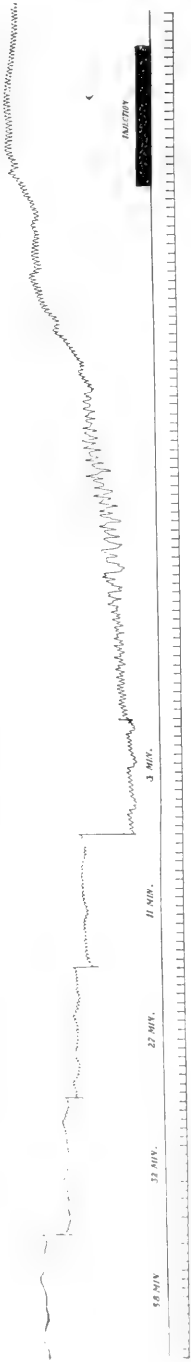

FIGURE 2.—Experiment VIII. Dog of 12.7 kilos. Preparation H. Injection of 0.05 gm. per kilo.

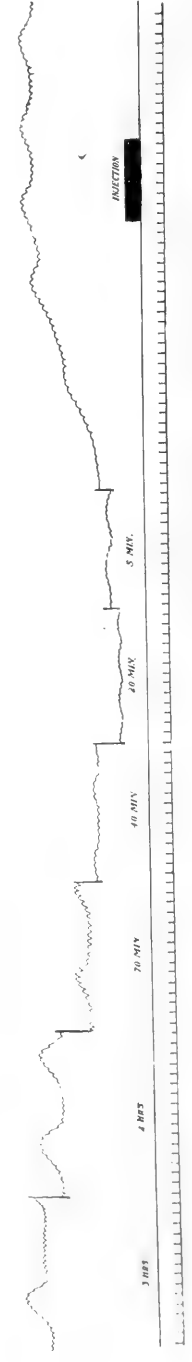

FIGURE 3.—Experiment VI. Dog of 17 kilos. Preparation H. Injection of 0.105 gm. per kilo.

laboratory.¹ Lymph was collected from the thoracic duct and analyzed in the usual manner. Urine was withdrawn through a catheter when desired.

Effects on blood-pressure. — The effects observed after the intravenous injection of solutions of nucleic acid on arterial pressure are summarized in the table on page 389.

Three typical manometer tracings are reproduced in Figs. 1, 2, and 3 from Experiments IX, VIII, and VI, which show the differences in the effects produced by varying doses. The curves were recorded from right to left. The line of zero pressure is marked below, and the time is recorded in seconds.

From these protocols it will be observed that the nucleates obtained from the wheat embryo, when injected rapidly in doses larger than 0.04 gram per kilo of body weight, produce a fall in arterial pressure comparable with that obtained by Bang with the quite different guanylic acid of the pancreas, and somewhat resembling the effects observed after injection of larger doses of albumoses. So small a dose as 0.024 gram per kilo was practically without influence; and with doses only slightly larger, the return of pressure to its previous height was rapid. The significance of the rate of injection is indicated by the results of Experiment III in which the nucleic acid was introduced more slowly into the circulation. In the case of similar phenomena observed after injections of albumoses, it has already been pointed out that the intensity of the vaso-motor effects is probably not so much a function directly of the absolute quantity injected as of the quantity in the circulation at any time, or, in other words, of the concentration of the substance in the blood.² A brief period of excitation was frequently noticeable, as in Bang's experiments, immediately after the injections were made.

Effects on blood-coagulation. — The action of the nucleic acid injections on extravascular blood-coagulation are summarized in the appended table. It will be seen that doses of 0.05 gram per kilo tend, in the dog, to diminish the coagulability of the blood. In Experiment III the injection was, as already observed, somewhat slower than usual. The dog may have been naturally immune. To what extent the diversion of the lymph from the blood stream has modified the tendency of the blood to remain fluid after injections of

¹ CHITTENDEN, MENDEL, and HENDERSON: This journal, 1899, ii, p. 144.

² CHITTENDEN, MENDEL, and HENDERSON: This journal, 1899, ii, p. 150.

SUMMARY OF OBSERVATIONS ON THE COAGULATION OF THE BLOOD.

Experiment.	Dose, per kilo.	CLOTTING-TIMES.											
		The upper line in each experiment gives the time, in minutes, which elapsed after the injection. The lower line gives the clotting-time.											
		h. m.	h. m.	h. m.	h. m.	h. m.	h. m.	h. m.	h. m.	h. m.	h. m.	h. m.	h. m.
IX ³	0.024 gm. H	Before injection ²	0 1	0 4	0 8	0 11	0 25	0 37	1 3	1 20	h. m.	h. m.	h. m.
		5	0 3	0 4	0 2	0 5	0 9	0 3	0 4	0 4	0 4	2d inject.	0 1
IX ³	0.044 gm. H	Before injection	0 5	0 11	0 14	0 20	0 45	0 53	2d inject.	0 1	0 8	0 21	
		5	0 4	0 2	0 5	0 3	0 1	0 2	Witte p.	0 7			
XIII ¹	0.05 gm. H	Before injection	0 1	0 5	0 10	0 20	0 31	0 54	1 14	1 45	2 15	2 30	2 45
		5	—	—	—	—	—	1 27	1 13	0 39	0 8	0 4	0 3
XI	0.105 gm. H	Before injection	0 2	0 8	0 25	1 1	1 20	1 45	2 15	2 45	2 52 ¹	3 0	
		4	0 25	—	—	—	—	—	—	—	0 7	0 2	
VII	0.15 gm. H	Before injection	0 1	0 3	0 8	0 14	0 24	0 34	0 46	0 55	2d inject.	0 3	0 7
		5	7 45	7 45	6 30	4 0	4 30	0 49	0 12	0 10	H.	0 3	0 4
V ¹	0.055 gm. K	Before injection	0 1	0 3	0 9	0 24	0 42	1 20	1 45				
		4	0 2	0 5	0 9	0 3	0 2	0 4	0 3				
III ¹	0.065 gm. K	Before injection	0 1	0 5	0 15	0 25	0 42	0 2	0 13				
		8	0 5	0 11	0 10	0 4	Witte p.	0 8	0 6				
II ¹	0.056 gm. F	Before injection	0 1	0 6	0 16	0 22	1 5	—	—				
		14	—	—	0 24	0 53	0 7	—	—				
Rabbit	0.10 gm. C	Before injection	0 2	0 10	0 22	0 45	0 55						
		9 ¹	0 22	0 10	0 12	0 1	0 9						

¹ Lymph experiments. See remarks, pp. 391 and 393.

² This is in each case the average time calculated from two or three observations.

³ A dash (—) denotes that the samples had not clotted after standing over night (20 hours).

⁴ Slower injection. Dog immune (?).

nucleic acid cannot be answered. It is quite possible, for example, that the absence of more marked effects on blood-coagulation in Experiment IV or V is attributable to the failure of an anti-clotting

TABLE SHOWING EFFECTS UPON THE LYMPH.

Experiment.	Time.	Lymph-flow in periods of 10 minutes. c.c.	Total solids in lymph. Per cent.	Ash in lymph. Per cent.	Remarks.
II Dog of 7 kilos Inject. of 0.056 gm. F per kilo	Before injection	1.3-1.5-1.5-1.4	5.05	0.95	Clots.
	After injection :				
	1st portion	13.7	6.49	0.92	Does not clot.
	2d portion	37.0	6.48	0.97	Does not clot.
	3d portion	26.0-21.0	6.50	0.91	Does not clot.
4th portion	13.0-5.5	5.84	1.18	Does not clot.	
V Dog of 11 kilos Inject. of 0.055 gm. K per kilo	Before injection	1.9-1.0-(1.5-1.5)	7.29	0.93	Clots.
	After injection :				
	1st portion	6.9	8.02	0.85	Does not clot.
	2d portion	4.7-(2.4-2.4)	8.06	0.89	Does not clot
	3d portion	(5.5-5.5)-(3.3-3.3)	7.62	0.99	Clots.
4th portion	(6.5-6.5)-(6.0-6.0)	7.70	0.87	Clots.	
VIII Dog of 12.7 kilos Inject. of 0.05 gm. H per kilo	Before injection	3.0-2.2-3.7	6.58	—	Clots.
	After injection :				
	1st portion	13.0-18.0	8.13	—	Does not clot.
	2d portion	12.8-12.3-(12.5-12.5)	7.84	—	Does not clot.
	3d portion	(11.5-11.5)-(9.0-9.0)	8.17	—	Does not clot.
4th portion	(7.0-7.0)	7.87	—	Does not clot.	
IV Dog of 13 kilos Inject. of 0.044 gm. H per kilo	Before injection	2.8-4.0	5.01	0.68	Clots.
	After injection :				
	1st portion	4.0-3.0	5.95	0.82	Clots imperfectly.
	2d portion	3.5-(3.0-3.0)-(4.6-4.6)	6.14	0.86	Clots.
	After injection of "peptone" (Witte)	10.2-7.8-6.0	7.07	0.85	Does not clot.
IX Dog of 12.5 kilos Inject. of 0.024 gm. H per kilo	Before injection	(20 min. periods) 2.5-1.0	—	—	
	After injection	3.0-4.0-5.5-2.5	—	—	

substance formed in the liver to reach the blood through the lymph. Other observations of this character have been made.¹

Effects on lymph-flow. — The characteristic effects of proteoses on the coagulability, composition, and rate of flow of lymph collected

¹ Cf. CHITTENDEN, MENDEL, and HENDERSON: *Loc. cit.*, p. 162.

from the thoracic duct is well known. In view of the resemblances already noted between the action of the nucleic acids and the proteoses on blood-pressure and coagulability typical lymphagogic effects might also be anticipated. The experiments confirm this. In five trials it was observed that small doses (Experiments IX, IV) produced only slight effects on the flow and the composition of the lymph. With larger doses which suffice to accelerate the flow of lymph, the latter becomes richer in solids, as after the injection of other lymphagogues of this class. Protocols of the experiments are given in the table on page 393.

Immunity. — It is well known that a sufficiently large injection of albumoses may confer a certain degree of immunity upon an animal. In such cases, when the blood returns to a condition under which it is once more coagulable as usual, a second injection fails to render it non-coagulable.¹ We have made a few observations regarding the influence of nucleic acid injections in this respect. In Experiments IX and IV in which small doses (0.024 gram and 0.044 gram per kilo respectively) of preparation **H** were injected, second injections of Witte peptone (0.5 gram per kilo) made after the blood-pressure and the clotting-time had returned to the normal, still produced the typical effects. The pressure quickly fell, and the blood became non-coagulable. In Experiment IV the usual effect of proteose injections on the lymph was also manifested, as the lymph protocols show. However, injection of 0.15 gram per kilo of preparation **H** in Experiment VII conferred immunity against a subsequent injection of a still larger dose (0.19 gram per kilo). The pressure-curve showed only a transitory fall, and the clotting of blood samples subsequently taken was not retarded. In Experiment III in which 0.065 gram per kilo of preparation **K** was injected rather slowly without producing very marked effects (see previous protocols), the animal was found to be immune towards a subsequent injection of 0.5 gram of Witte peptone per kilo, at least as far as retardation of blood-clotting was concerned.² A single experiment (I) on a medium-sized rabbit which received an intravenous injection of one-third gram of wheat nuclein **C** (4.56 per cent of phosphorus) equivalent to about 0.05 gram of nucleic acid per kilo of body weight, may be recorded here. The animal was anesthetized with one-half gram urethane followed by ether adminis-

¹ Cf. CHITTENDEN, MENDEL, and HENDERSON: *Loc. cit.*, p. 158.

² The slight effects observed in this animal may have been due to a natural immunity which has sometimes been noted in dogs.

tration. The blood samples clotted in nine and one-half minutes before the injection (30 c.c. of fluid) which lasted nineteen seconds. Blood samples taken two, ten, twenty-two, forty-five, and fifty-five minutes after, clotted in twenty-two, ten, twelve, one, and nine minutes respectively, the pressure fell more gradually than was usually observed in dogs, and began to rise again in forty minutes. Immediately after the injection, disturbances in respiration and other evidences of excitation were observed, as in the case of the dogs. Bang's similar observations on the relative immunity of the rabbit to injections of pancreas nucleoproteid have been mentioned (page 388).

THE FATE OF NUCLEIC ACID IN THE BODY.

The fate of nucleic acid (or nucleins) in the body has usually been studied by feeding experiments on man and animals. So far as we recall, no extensive study has heretofore been made of the transformations which occur when the products are introduced in some other way than by the alimentary canal. Consequently it is not definitely known whether an important influence on the subsequent utilization of the nucleic acid radicals is exerted by the digestive processes. From the experiments available, it seems probable that the nucleic acid radical is split up only to a very slight extent, if at all, in the digestive tract. The proteid compounds of the nucleic acids (nucleins) may be broken up by the digestive enzymes into an organic phosphorus-containing portion and albumose or peptone. But there is no evidence that the purin constituents are liberated before absorption.¹ We have introduced nucleic acid or its compounds into the organism by direct injection into the blood-current, into the peritoneal cavity, under the skin and per rectum, and have attempted to follow the reactions of the substance introduced by searching for its characteristic metabolism product, allantoin, in the urine. Some details are given below.

Intravenous injection.— The allantoin was separated by crystallization from the concentrated urine, and identified by its characteristic crystalline appearance and melting point (210°–220° C.). The animals were either starved on the preceding day, or fed on a “purin-free” diet of casein, cracker-meal, milk, and lard.

¹ Cf. POPOFF: *Zeitschrift für physiologische Chemie*, 1894, xviii, p. 533; MILROY: *Ibid.*, 1896–97, xxii, p. 307; LOEWI: *Archiv für experimentelle Pathologie und Pharmakologie*, 1901, xlv, p. 165.

1. In Experiment VII (see previous protocols), the dog of 8 kilos received two injections containing a total of 2.7 grams of preparation **H** at an interval of less than two hours. The urine was removed by means of a catheter at intervals of two-thirds, six, and seven and one-half hours after the last injection. From the first portion a very small quantity of allantoin was obtained; from the second, 0.076 gram (m. p. 217°); from the third, 0.010 gram (m. p. 219°) before the animal was killed.
2. From the urine obtained in Experiment VIII, in which 0.6 gram of **H** was injected into a dog of 12.7 kilos, no allantoin could be separated.
3. A cat of 4 kilos was anaesthetized with 75 mgm. of chloralose followed by A. C. E. mixture. One and one-half grams of sodium nucleate prepared by dissolving preparation **H** in 14 c.c. of very dilute sodium hydroxide were injected as aseptically as practicable, from a burette through a cannula into the jugular vein in thirteen and one-half minutes. Somewhat later a second slow injection of 2.14 grams dissolved in 23 c.c. of fluid followed. The wound was sewed up and the animal placed under observation. The urine (100 c.c.) collected on the following morning contained 0.112 gram allantoin (m. p. 217°). The cat remained asleep during this entire day and was found dead on the second morning. No more allantoin could be obtained.
4. A medium-sized cat was anaesthetized with ether. Two and one-half grams of yeast "nucleinic acid" (P. D. and Co.), dissolved in 38 c.c. of very dilute sodium hydroxide, were injected into the jugular vein in thirty minutes. The effect on respiration, which became deep and prolonged, was very noticeable. The wound was closed, and the animal sat up again in fifteen minutes. The urine collected at the end of the next hour was acid, and contained much proteid; but no allantoin separated. From the urine of the following three hours an abundant yield of allantoin was obtained; and small quantities were separated from the next day's urine. Proteid continued to be present in the acid urine.¹

Intraperitoneal injection. — In his study of the interrelation between uric acid excretion and leucocytosis Kuehnau² made intraperitoneal injections of thymus emulsions and of thymus nuclein in dogs. This procedure gave rise in each case to an increased output of uric acid which the author was unable to attribute entirely to leucocyte influences. A fall in body temperature, noted after the thymus injections, was attributed to "peritoneal shock." Physiological salt solution thus introduced produced no change in the uric acid output.

¹ MR. WHITE has recently observed a large output of allantoin after the injection of urates into the systemic and portal circulation. The investigation is being continued.

² KUEHNAU: *Zeitschrift für klinische Medicin*, 1895, xxviii, p. 561.

Our animals were fed on a "purin-free" diet (milk and cracker-meal) just before and during the experiments. The intraperitoneal injections were made (without anæsthesia) with a large hollow needle. Vomiting and diarrhœa were common symptoms observed after the injections were made.

5. A dog of 10 kilos received 3 grams of yeast "nucleinic acid" (P. D. and Co.), dissolved in 125 c.c. of water containing a trace of sodium hydroxide. The urine collected on this and the following day was acid and contained much proteid. Large quantities of allantoin were separated, particularly from the portions obtained within the first twenty hours. The dog recovered completely, and four days later received a second injection (4 grams) for the purpose of ascertaining the effects on the uric acid output. The results were negative. Three days later the same dog was given a third injection of 8 grams of yeast "nucleinic acid." The symptoms already described were marked, and the animal appeared stupid. Within three hours allantoin was excreted in the urine; and from the urine of the following two hours there was separated the largest yield of allantoin obtained from one animal. No marked increase in uric acid output was noted.
6. A medium-sized dog received an intraperitoneal injection of 4 grams of yeast "nucleinic acid." Within an hour vomiting ensued, followed by a rise in temperature and indifferent attitude. About two hours later 4 grams more were injected. The symptoms were not aggravated. The urine collected in the succeeding five hours was very acid, contained proteid and only little allantoin.
7. A large cat received an intraperitoneal injection of 4 grams of the yeast "nucleinic acid." Within five minutes vomiting ensued and the animal became indifferent. Seven hours later the cat was found dead. The 30 c.c. of urine previously collected contained a very small quantity of allantoin.

Subcutaneous injection. — Experiments involving subcutaneous administration of nuclein preparations are fairly numerous in medical literature. They have been carried out mainly with reference to their bearing on leucocytosis, although the effect on uric acid output has been studied in a few instances.¹

8. The dog used in Experiment 5 received subcutaneously 4 grams of yeast "nucleinic acid" in 50 c.c. of very dilute sodium hydroxide. Severe

¹ KUEHNAU: *Zeitschrift für klinische Medicin*, 1895, xxviii, p. 564; MILROY and MALCOLM: *Journal of physiology*, 1899, xxv, p. 105; BURIAN and SCHUR: *Archiv für die gesammte Physiologie*, 1901, lxxxvii, p. 304.

diarrhœa followed, but further symptoms were not marked. The urine collected during the remainder of the day contained a small quantity of allantoin.

Burian and Schur have noted a marked rise in uric acid output in dogs after subcutaneous injections of sodium nucleate (from thymus). This was accompanied by increased nitrogen excretion and fever; the authors regard the uric acid eliminated in this case as *endogenous* in origin, and attribute it to pathological processes (cell destruction?) provoked. In the absence of nitrogen estimations and leucocyte counts, we are unable to deny a similar origin to the allantoin obtained in the preceding experiments. It seems unlikely, however, that the amount of allantoin obtained in some of the experiments (No. 5, for example) is entirely attributable to cellular disintegration and endogenous purin sources. The further possibility of such a reaction is suggested, however, by the experiments of Borissow,¹ who found allantoin in the urine of the dog after poisoning with hydrazine sulphate. In the following feeding experiments, the absence of marked toxic symptoms makes it more probable that the allantoin excreted was at least in part exogenous in origin and derived from the nuclein compounds fed.

Feeding experiments. — Numerous feeding experiments with glandular materials rich in nuclein compounds are recorded in the literature. It will suffice here to refer to those observations which were made with the isolated substances from which alone more definite conclusions regarding the action of the nucleic acid components can be drawn. In addition to the experiments of Stadthagen and Gumlich already mentioned, nucleins or nucleates have been fed by Horbaczewski,² Richter,³ Mayer,⁴ Jerome,⁵ Minkowski,⁶ Milroy and Malcolm,⁷ and Loewi.⁸ Minkowski was the first to describe allantoin

¹ BORISSOW: *Zeitschrift für physiologische Chemie*, 1894, xix, p. 499.

² HORBACZEWSKI: *Monatshefte für Chemie*, 1889, x, p. 624; 1891, xii, p. 221 (spleen nuclein: man and rabbit).

³ RICHTER: *Zeitschrift für klinische Medicin*, 1895, xxvii, p. 311 (sodium nucleate from thymus: man).

⁴ MAYER: *Deutsche medicinische Wochenschrift*, 1896, xxii, p. 186 (spleen nuclein: man).

⁵ JEROME: *Journal of physiology*, 1899, xxv, p. 98 (yeast nuclein; man).

⁶ MINKOWSKI: *Archiv für experimentelle Pathologie und Pharmakologie*, 1898, xli, p. 493 (salmon nucleic acid: dog and man).

⁷ MILROY and MALCOLM: *Journal of physiology*, 1898, xxiii, p. 217 (nucleic acid: man).

⁸ LOEWI: *Archiv für experimentelle Pathologie und Pharmakologie*, 1901, xlv, p. 157 (various nucleic acids and nuclein products; man).

as a metabolism product of an isolated nucleic acid in the dog. The above observers have noted a pronounced rise in uric acid output. The apparent relation between uric acid (noted in man) and allantoin (in the dog) has already been suggested. A few extracts from our protocols follow. The negative results which were occasionally obtained, are not recorded here, since they do not affect the observations made, and are not surprising in view of the difficulty in separating small quantities of allantoin, and in the absence of data regarding the extent to which the substances fed were absorbed. As before, the animals were always fed on a "purin-free" diet of milk, cracker-meal, and lard for some time previous to the feeding experiment with the nucleic acid compounds.

9. Dog of 6.8 kilos. On a "purin-free" diet, such as that described above, no allantoin appeared in the urine. During two days a total of 17 grams of preparation **D** (containing 2.9 per cent of phosphorus and equivalent to about 5.6 grams of nucleic acid) were added to the diet. The urine of these days yielded 0.21 gram of allantoin (m. p. 217°). Two days later, when the urine was again free from allantoin, 30 grams of desiccated salivary glands¹ of the ox were added to the diet. The urine of the following day furnished 0.023 grams of allantoin (m. p. 219°).
10. Dog of 3.3 kilos. The diet consisted of casein, cracker-meal, and lard. On one day, 5 grams of preparation **H** were added to the food. The urine for this day yielded 0.445 gram of allantoin (m. p. 219°). None was obtained on the following days, even when 15 grams of Armour's desiccated salivary gland were added to the diet.
11. A cat of medium size was fed on cracker-meal and milk. In the course of two days, 10 grams of preparation **D** (equivalent to about 3 grams of nucleic acid) were added. A small yield of allantoin (m. p. 217°) was obtained on the day following only. The subsequent addition of 0.36 grams of preparation **F** produced no detectable trace of allantoin. In another cat negative results were obtained after feeding 6 grams of preparation **D**.
12. A kitten about four weeks old was fed on milk. The daily addition of 1 gram of yeast "nucleinic acid" to the milk was followed by an excretion of allantoin. The urine previously collected was free from the latter.
13. The attempt to induce an excretion of allantoin by feeding emulsions of thymus glands to rabbits was unsuccessful.

¹ Specially prepared for us by ARMOUR and Co., Chicago.

Rectal feeding.—Mochizucki¹ has shown that the administration of thymus gland substance per rectum is also followed by a typical increase in uric acid excretion in man. In two cases out of three experiments on dogs, we have obtained allantoin excretion after a similar procedure. The third animal eliminated uric acid in apparently increased amount. In each instance a "purin-free" diet was simultaneously fed. Thymus glands were macerated with water and strained through cloth. About 70 c.c. of the resulting emulsion were injected after addition of 2 grams of common salt and 5–8 drops of laudanum. Sometimes the gut was emptied on the previous day by an enema of soap and water. A single experiment on man will be referred to later.

Experiments on man.—Milroy and Malcolm² have studied the effect of nucleic acid on nitrogenous metabolism and leucocytosis in man. They found only a very small rise in uric acid output. The P_2O_5 elimination and the number of leucocytes were both noticeably increased, although only one-half and one gram of nucleic acid were taken respectively on the two days selected. They were unable to give larger doses of nucleic acid because of certain somewhat disagreeable symptoms (severe muscular tremors) which arose after the larger quantity had been given. Loewi³ has attributed the latter to some foreign toxicity in the nucleic acid fed. In his own experiments, larger quantities (30 grams) were taken without apparent ill effects, although he noted unfavorable symptoms after taking a commercial preparation of sodium nucleate prepared from yeast. Neumann⁴ has reported the absence of disagreeable symptoms after administration of the thymus nucleic acid. Loewi concluded from his experiments that uric acid is the only specific nitrogenous end-product of nuclein metabolism in man.

The present feeding experiments were carried out on two of us. The daily diet selected from foods which are practically "purin-free," was maintained unchanged throughout the entire periods. Preparation **M**, containing 7.35 per cent of phosphorus and 16.3 per cent of nitrogen was added to the diet on two successive days. It was dis-

¹ MOCHIZUCKI: *Archiv für Verdauungskrankheiten*, 1901, vii, p. 221.

² MILROY and MALCOLM: *Journal of physiology*, 1898, xxiii, p. 227.

³ LOEWI: *Archiv für experimentelle Pathologie und Pharmakologie*, 1901, xlv, p. 157.

⁴ NEUMANN: *Verhandlungen der physiologischen Gesellschaft*, Berlin, 1898. No. 11, 12, 13 (according to LOEWI).

solved in a minimum quantity of dilute sodium hydroxide and added to the milk taken at noon. The total daily food consisted of :

		B. W.	F. P. U.	
		Grams.	Grams.	
Diet	{	eggs	330	445
		bread	275	275
		milk	1500	1850
		butter	75	96
		water	150	115
estimated to contain				
{	proteid	112	138	
	fat	149	191	
	carbohydrate	226	235	

and calculated to yield 2770 Cal. 3310 Cal.

The food was taken in three portions, about one gram of salt being added at each meal. The urine and fæces were collected for each twenty-four hours and analyzed. The fæces were covered with alcohol containing a few drops of sulphuric acid, and were dried on a water-bath and pulverized. Nitrogen was estimated by the Kjeldahl-Gunning method; P_2O_5 in the urine by titration with uranium solution, in the fæces, gravimetrically by Neumann's method;¹ uric acid by the Ludwig-Salkowski process; ethereal SO_4 by Baumann's method. On one day nucleic acid (dissolved as usual and mixed with a part of the daily milk portion and a few drops of laudanum) was introduced per rectum through a long flexible catheter. The intestine had previously been subjected to an enema of soap-water. (See B. W., 8th day.) The data are summarized in the table on page 402.

Leucocyte counts made on the two days before and during the nucleic acid feeding period showed only slight changes, if any. Thus the counts on B. W. during the first three days gave the following numbers: 5780-5460-5780-5150-7812; during the nucleic acid days: 5200-6400-5000-5210-5780-7320-6580. The counts on F. P. U. were as follows; on the first two days: 9360-8120-10620; on the nucleic acid days: 10620-11240-11400-12280.

Both subjects complained of slight muscular soreness on one of the nucleic acid days. The writer was at the time inclined to over-

¹ NEUMANN: Archiv für Physiologie, 1897, p. 552; cf. also ZADIK: Archiv für die gesammte Physiologie, 1899, lxxvii, p. 2.

METABOLISM EXPERIMENTS ON MAN.

F. P. U. 24 years old. Body weight, 70 kilos.

Day.	Vol. c.c.	Sp. gr.	URINE.				FÆCES.				
			Total nitrogen. Gms.	P ₂ O ₅ . Gms.	Uric acid. Gm.	Total SO ₄ . Gms.	Etheral SO ₄ . Gm.	Moist weight. Gms.	Dry weight. Gms.	Total nitrogen. Gms.	P ₂ O ₅ . Gms.
1	985	1.024	16.615	2.636	0.519	3.585	0.1300	251	88	4.041	4.285
2	1119	1.021	17.279	3.127	0.412	3.172	0.1397	273	143	6.567	6.964
3	1305	1.023	20.113	3.780	0.333	3.996	0.1646	208	40	1.837	1.948
4	1260	1.025	19.779	3.992	0.381	4.038	0.1729	180	49	2.250	2.386
5	1300	1.027	20.918	4.477	0.532 ¹	3.979	0.1671	125	36	1.580	1.443
6	1150	1.026	16.692	3.507	0.564 ¹	3.067	0.1332	155	50	2.195	2.005
7	1325	1.022	19.266	3.843	0.555	3.883	0.1687	174	58	2.515	2.175
8	1220	1.027	18.843	3.793	0.453	3.793	0.1498	198	53	2.299	1.987
9	1160	1.026	17.966	3.884	0.490	3.733	0.1319	69	22	0.954	0.825

4 gm. nucleic acid M fed
4 gm. nucleic acid M fed

B. W. 23 years old. Body weight, 62.7 kilos.

1	1505	1.017	13.642	2.517	0.326	2.885	0.1408	36	15	0.631	0.934
2	1140	1.023	15.960	3.208	0.366	3.555	0.1522	98	31	1.304	1.931
3	1002	1.024	16.443	3.231	0.339	3.457	0.1734	76	23	0.967	1.432
4	1400	1.021	17.457	3.664	0.568	3.559	0.1390	71	37	1.594	2.900
5	1520	1.020	18.042	3.918	0.503	3.619	0.1478	191	55	2.369	4.312
6	1044	1.026	16.292	3.369	0.345	3.710	0.1325	91	29	1.076	1.754
7	1031	1.026	17.662	3.205	0.343	3.473	0.1759	130	30	1.113	1.815
8	1051	1.024	17.493	3.010	0.326	3.643	0.1804	69	20	0.742	1.274
9	1067	1.026	16.815	3.547	0.375	3.391	0.1704	126	35	1.272	2.229

¹ Uric acid crystals separated from the urine on standing. The urine was very acid to litmus.

look any direct bearing of these remarks; their possible significance was again emphasized after reading the experience of the subjects of Milroy and Malcolm and of Loewi. For this reason also no larger quantities of nucleic acid were fed to man.

The results obtained with F. P. U. are somewhat irregular, and indicate a slight "lag" in the excretions on certain days. In each subject a noticeable increase in uric acid output followed the ingestion of the nucleic acid. In the absence of any other purin constituent in the diet and (in B. W. at least) of any marked leucocytosis (and probable leucolysis), we must attribute the increase in uric acid, as Loewi does, directly to the nucleic acid ingested. It is, in the language of Burian and Schur, exogenous in nature. The low average daily output of endogenous uric acid in our two subjects on a "purin-free" diet falls within the limits ascertained by Burian and Schur¹ in different individuals.

SUMMARY.

The more important observations recorded in this paper indicate that the vegetable nucleic acid obtained from the wheat embryo resembles, in its physiological effects, the guanylic acid of the pancreas. Introduced in sufficient doses into the circulation, it may produce a fall in arterial pressure; a change in the coagulability of the blood; an increase in the flow of lymph and a change in its composition; and perhaps, also, a degree of immunity toward subsequent injections.

The ingestion of nucleic acid is followed in man by an increased output of uric acid, and in the dog by the excretion of allantoin. These products correspond in either case to only a portion of the purin radicals introduced. In animals, allantoin excretion was also observed after the introduction of vegetable nucleic acids into the body per rectum, intravenously, intraperitoneally, and subcutaneously. Some features of intermediary purin-metabolism are discussed.

¹ BURIAN and SCHUR: *Archiv für die gesammte Physiologie*, 1900, lxxx, p. 302.

THE ACTION OF ACIDS AND ACID SALTS ON BLOOD-CORPUSCLES AND OTHER CELLS.

By S. PESKIND,¹

[From the Physiological Laboratory, Western Reserve University.]

WHILE investigating a large number of laking agents, in conjunction with Dr. G. N. Stewart, I made the observation that small quantities of ferric chloride or hydrochloric acid cause agglutination and precipitation of blood-corpuscles.

To determine what substances would give this reaction, the following list of chemicals was tested. The purest reagents were used, Merck's and Schuchart's for the most part. Defibrinated dog's blood was employed in all the experiments, although the reaction was found to take place also with human blood, cow's blood, and chicken's blood.

The following acids caused good agglutination and precipitation :

Sulphuric	Acetic	Chlorine water
Hydrochloric	Oxalic	Bromine water
Nitric	Citric	
Phosphoric	Tartaric	
Iodic	Lactic	
Chromic	Tannic	
Molybdic	Pyrogallic	
Phosphomolybdic	Benzoic	
Phosphotungstic	Hippuric	
	Sulphanilic	

The corpuscles precipitated by the above acids laked very rapidly. No extraneous precipitate (*i. e.*, no precipitate of serum constituents) was thrown down with the corpuscles.

The following acids did not produce agglutination and precipitation :

Arsenious	Uric
Boric	Eosic
Hydrogen sulphide	Acid fuchsin
Carbon dioxide	
Carbolic	
Osmic	

¹ H. M. Hanna Fellow for 1902.

Very large as well as very small amounts of a solution of arsenious acid failed to give the reaction with whole blood or washed corpuscles. After adding the arsenious acid a drop of 0.2 per cent hydrochloric acid was added, which immediately gave a good reaction. Washed corpuscles treated with excess of hydrogen sulphide turned a greenish color, owing to the formation of sulfo-methæmoglobin.¹

Pyrogallic acid changed the color of washed corpuscles to olive green when just enough was added to cause precipitation.

Chromic acid, if used in slight excess, hardens the corpuscles at the same time that it precipitates them, so that they show no laking after many hours. Under the microscope, they look angular, have sharp margins, and are clearly hardened.

The following salts were tested. All the salts mentioned in the table cause agglutination and precipitation, *except those marked with an asterisk.*

“A” denotes acid reaction, “N” neutral reaction.

	Reaction of solutions to litmus paper.
Sodium acid sulphate	A
*Potassium acid tartrate	A
*Potassium and sodium tartrate	N
*Potassium and antimony tartrate	A
Potassium acid sulphate	A
*Calcium glycerinphosphate	A
*Ferrous sulphate	N
Ammonio-ferrous sulphate	A
Hypophosphite of iron (ferrous)	A
Ferric nitrate	A
Ammonio-ferric sulphate	A
Dialyzed iron	Bleached litmus
Ferric chloride	A
*Pyrophosphate of iron	N
*Nickel sulphate	N
*Nickel and ammonium sulphate	N
Zinc sulphate	A
Zinc chloride	A

¹ HOPPE-SEYLER: Handbuch der chemischen Analyse, p. 281.

	Reaction of solutions to litmus paper.
Aluminium chloride	A
Aluminium sulphate	A
Alum (d'ble sulphate of potassium and aluminium)	A
*Cobalt chloride	Slightly A
*Cobalt nitrate	Slightly A
*Manganese sulphate	N
*Manganese nitrate	Slightly A
*Chrome alum	A
*Potassium bichromate	A
*Ammonium chromate	N
*Potassium chromate	N
Copper sulphate	A
*Lead acetate	N
*Mercuric cyanide	N
*Mercuric bichloride	N
Mercury bisulphate	A
Silver nitrate	A
Gold chloride	A
Gold and sodium chloride	A
*Platinic chloride	A
Stannous chloride	A
Uranium acetate	A
Ammonium molybdate	A
*Sodium tungstate	N
*Quinine bisulphate	A
*Methylene blue	A

The reagents to be tested were dissolved in 0.9 per cent sodium chloride solution in such proportion that the solution contained from 0.1 per cent to 0.5 per cent of the substances. All these solutions are therefore slightly hyperisotonic. In working with leucocytes (see experiments on leucocytes), 0.9 per cent sodium chloride solutions containing about 0.04 per cent of the reagents were employed, as stronger solutions did not allow the reaction to take place. Some reagents are but slightly soluble in water, *e. g.*, hippuric acid. Of

these a saturated solution in 0.9 per cent sodium chloride solution was used.

In making the experiments a few drops of defibrinated dog's blood were suspended in a little 0.9 per cent saline (a 10 per cent blood-suspension is best), and the reagents were added drop by drop until the blood-corpuscles came down as a flocculent precipitate. One can thus determine quite accurately the amount of precipitant necessary for the exact precipitation of all the corpuscles. If undiluted blood is used, it becomes solidified from the precipitate of corpuscles that forms, and one cannot discern the exact points where precipitation begins and ends.

Excess of reagent must be avoided. — A slight excess causes rapid laking of the precipitated corpuscles, if the latter be kept at room temperature. But if the precipitated blood be kept on ice at 0°, the laking is retarded for many hours. If more than a slight excess of precipitant is added, the reaction will not take place. In the case of some reagents, where every excess must be avoided in order to demonstrate the reaction, it is advisable to reverse the procedure given above. Blood is added a little at a time to a weak solution of the substance to be tested. As long as the reagent is in excess, no precipitation occurs, but when enough blood has been added an immediate agglutination and precipitation of the corpuscles takes place.

On looking over the above table, it is observed that many inorganic and organic acids produce agglutination and precipitation of blood-corpuscles, the only exceptions among the acids tested being osmic acid, arsenious acid, boric acid, uric acid, hydrogen sulphide, carbonic acid (carbon dioxide), carbolic acid. It is seen further that many salts give the reaction. The active salts have the following characteristics: they all have a strongly acid reaction; and they have for bases one of the following heavy metals, iron, zinc, aluminium, silver, mercury, gold, tin, molybdenum, exceptions being the acid sulphates of sodium and potassium, which must be included in the list of active salts. Only the acid salts of these metals cause precipitation of the blood-corpuscles. Cream of tartar, which has a strongly acid reaction, as also chrome alum, calcium glycerine-phosphate, potassium and antimony tartrate, quinine bisulphate, all strongly acid salts, do not give the reaction. Combinations which contain the metalloids, boron, arsenicum, and antimony are apparently unable to agglutinate and precipitate corpuscles. No neutral salt, no matter what metal it

has for a base, was found to give the reaction. One might think that possibly there was enough free acid contained in the acid salts to cause precipitation of the corpuscles, but it will be shown later that the reaction is due to the salts themselves, and not to free acids which might exist as impurities.

The corpuscles precipitated by acids lake very rapidly at room temperature, if even a slight excess of acid be present. The ferric chloride precipitates lake not so readily, but still very rapidly. Copper sulphate precipitates remain unlaked for a considerable time, even at room temperature. In another part of the paper will be described in detail a procedure for preventing the laking of precipitated corpuscles.

The flocculent precipitate of blood-corpuscles produced by any of the above-mentioned acids settles rapidly, leaving a clear and colorless supernatant liquid which shows no evidence of laking and no extraneous macro- or microscopic precipitate, *e. g.*, of globulin. On centrifugalizing for two or three minutes, the corpuscles are found to be agglutinated into a firm gelatinous mass at the bottom of the centrifuge tubes. With the microscope, no extraneous precipitate can be seen in or around the masses of agglutinated blood-corpuscles. If ferric chloride is used for precipitating, a small amount of a white granular precipitate is seen on the top of the cake of corpuscles and in the supernatant liquid.

In the case of copper sulphate, a greenish-white granular precipitate is seen above the sediment of corpuscles, and, with the microscope, in and around the masses of corpuscles. Similar precipitates are found in the case of other acid salts used. They are soluble in a few drops of acid or alkali and consist apparently of globulin. They may be removed almost completely by several washings with 0.9 per cent saline, and subsequent centrifugalization, as they are very light, and are floated off by the saline and possibly in part dissolved.

The color of the sediment of blood-corpuscles precipitated by any of the reagents (with two exceptions) is perfectly normal, provided the reagents are not added in excess. Only in the case of pyrogalllic acid and gold chloride have I found the color of the corpuscles altered in the precipitation, due to a simultaneous action on the hæmoglobin.

Microscopic examination of the precipitate of blood-corpuscles produced by acids shows the following: One sees big clumps consisting of agglutinated masses of red corpuscles of normal color, absolutely no extraneous precipitate being visible. The contour of the cor-

puscles is perfectly filled out, and even if they are very much crenated before, they look full and rounded after precipitation, all the crenation having disappeared, showing that something has entered the corpuscles. Corpuscles precipitated by ferric chloride and other acid salts tend to assume a globular form, and usually are sub-normal in size.

The corpuscles are all quite uniform in size, even when in the original blood-suspension they may have shown marked disparity in regard to size.

The corpuscles show no swelling if the reagents are not in excess. If the precipitated corpuscles are watched, on the slide, at room temperature, they will (if even a very slight excess of reagent has been added) be seen to swell, grow paler and dimmer, and then lose their hæmoglobin; finally only agglutinated masses of stromata remain.

If a slight trace of a *caustic* alkali (ammonia or sodium hydrate) is added to the liquid containing the precipitated corpuscles, and the whole shaken a little, the clumping is immediately and completely broken up, so that the corpuscles remain suspended singly in the liquid and do not settle for a long time, just as in normal blood. Under the microscope no agglutinated masses are to be seen, each corpuscle being separate from its fellows. On adding one of the precipitants to this restored blood, the corpuscles are reprecipitated. A moderate amount of serum added to precipitated blood is unable to restore the normal suspension of the corpuscles.

If blood is added to an excess of reagent, agglutination and precipitation do not occur until the blood added reaches a certain amount. It seems that an excess of acid or acid salt surrounding the corpuscles is inimical to the agglutination and precipitation of the latter, although red corpuscles once agglutinated always remain in that condition in spite of any excess of reagent that is afterward added.

If corpuscles precipitated by hydrochloric acid or ferric chloride are washed, well shaken with saline and centrifugalized, it becomes progressively more difficult after each washing to remove the corpuscles by centrifugalization. If this process be repeated five or six times, and the corpuscles be shaken well each time, they will resume an almost normal suspension, which becomes almost quite normal if the corpuscles are allowed to stand in the ice-chest over night suspended in saline solution.

If these washed hydrochloric acid or ferric chloride corpuscles are suspended in saline they can be reprecipitated by very minute quanti-

ties of the precipitants. The precipitates have the same macroscopic and microscopic appearances as when ordinary blood is acted upon by the same reagents, the only difference being that the extraneous granular precipitate ordinarily seen when the metallic salts are used is absent in this case.

What takes place in the precipitated corpuscles when they are so thoroughly washed that they resume, practically, their normal suspension and can be reprecipitated on again adding the reagents? Is the precipitant removed from the corpuscles by an osmotic process which is favored by removal of all adherent serum? This is very improbable, as the combination between reagent and corpuscle is a firm one, as will be shown elsewhere.

Two other explanations may be advanced. We know that alkalis break up the agglutination of the corpuscles. Possibly the distilled water used in preparing the saline contains a sufficient amount of free alkali (ammonia?) to combine with the precipitating acid or salt contained in the corpuscles. This again is hardly probable, as but a very small amount of ammonia exists in distilled water. The most reasonable explanation is that the alkali present in the interior of the corpuscles diffuses toward the periphery, and on reaching the surface layer of the corpuscle (which for convenience we shall call the envelope) neutralizes the acid or acid salt contained therein. As soon as the normal alkaline reaction of the envelope is restored wholly or in large part, the agglutination will be broken up. The repeated washings required in order to restore the normal suspension of the corpuscles acts, according to this view, by removing the acid or acid salt on the outside of the corpuscles, which would tend to keep the envelope acid. As an illustration, the following experiment may be quoted.

The washed corpuscles of one cubic centimetre of dog's blood were diluted with ten parts saline, and 0.2 per cent hydrochloric acid in saline was added drop by drop, and the tube shaken. After 0.2 or 0.3 c.c. of the acid has been added, good precipitation occurred. On shaking the tube thoroughly, the agglutinated and precipitated corpuscles resumed their normal suspension. Another drop of the acid was added, and again the corpuscles were agglutinated and precipitated. After vigorous shaking, the corpuscles again resumed their normal suspension. This could be repeated until 0.6 c.c. of acid had been added, when the corpuscles came down as a very heavy flocculent precipitate. The agglutination could no longer be broken up,

and soon after the corpuscles laked. It seems probable that in this case after each addition of the acid the alkali of the interior of the corpuscle diffused to the surface and neutralized the acid in the surface-layer of the corpuscle. After 0.6 c.c. of the acid had been added, the alkali was almost completely used up, and the agglutination could not be destroyed.

In what ways can agglutination and precipitation of corpuscles be prevented? I made attempts to harden the surface of the corpuscles (or envelope) by small quantities of hardening agents, thinking thereby to make them incapable of being agglutinated. In the case of washed corpuscles, precipitation cannot be prevented by adding 1 or 2 per cent of formaldehyde in 0.9 per cent sodium chloride, or 0.2 per cent osmic acid (in sodium chloride solution) immediately before the addition of the precipitant. Blood-corpuscles hardened in 2 per cent formaldehyde (in saline) for forty-eight hours are still agglutinated and precipitated by ferric chloride. The hæmoglobin in these corpuscles is thoroughly fixed, as is shown by their dark brown color, and the fact that a large excess of laking agents, such as hydrochloric acid, fails to lake them.

Why does cold retard the laking of corpuscles precipitated by acids and acid salts? Loewy and Zuntz have noticed that in the titration of blood-corpuscles with acids in order to determine their alkalinity, lower figures were obtained if the titration were carried out at 0° C. So it seems most likely that the diffusion of the alkalies in the interior of the corpuscles towards the surface is greatly retarded by cold. This would serve to explain the effect of cold in retarding laking.

Incidentally an experiment is perhaps worth mentioning which seems to show that after the action of precipitating agents the hæmoglobin of the corpuscles is in a peculiarly labile condition, so that a very slight change is sufficient to cause its liberation. After a slight excess of ammonio-ferrous sulphate the corpuscles settle rapidly, leaving a perfectly colorless supernatant liquid. Microscopically, agglutinated masses of normal looking cells are to be seen. On slightly pressing the cover slip, the hæmoglobin was seen to pass out of the corpuscles and away from the point of pressure, leaving almost hæmoglobin-free corpuscles.

If blood be allowed to run direct from an artery into saline solution containing an amount of the ferric chloride exactly calculated to precipitate all the corpuscles, the serum will not clot even after several days.

The following experiments were made. Four glass graduates were employed.

Graduate I contained 3.9 c.c. of a solution of 1.2 per cent ferric chloride in saline + sufficient saline to make 40 c.c. Into this mixture 10 c.c. of blood was allowed to flow directly from a cannula in the carotid of a dog, and stirred thoroughly. The blood-corpuscles were precipitated immediately and completely. After half an hour no clotting had taken place. The mixture was centrifugalized and the serum decanted. The blood cake was absolutely unlaked after twenty-four hours, standing at room temperature. The serum, which was *perfectly neutral* in reaction, did not clot after two days.

Control. Graduate II contained four parts saline. One part blood was allowed to flow in, and mixed. After three minutes the blood was completely clotted.

Graduate III contained 2 c.c. of ferric chloride + saline up to 15 c.c. Added 5 c.c. blood; precipitated; no clotting after half an hour. Centrifugalized; serum unclotted after two days.

Control. Graduate IV contained three parts saline + one part blood. Clotted within three minutes.

Whether the absence of clotting was due to the precipitation of all the corpuscles which thus prevented any liberation of fibrin ferment (which is the most probable cause), or whether it was due to the neutralization of the alkalinity of the serum, must be determined by subsequent experiment.

What constituent of the blood is concerned in this reaction — the serum or the corpuscles? That the serum constituents take no part, is shown by the fact that thoroughly-washed corpuscles, absolutely free from serum,¹ are agglutinated and precipitated by the same reagents which act on entire blood.

In this connection it may be of interest to give the results of some quantitative experiments showing the amounts of reagents required to produce the reaction.

Thoroughly washed dog's corpuscles were suspended in 0.9 per cent sodium chloride solution, so that 1 c.c. contained 2,150,000 corpuscles (by

¹ The corpuscles are washed until the last wash water (0.9 per cent saline) gives no precipitate with ferro-cyanide of potassium and acetic acid, showing an entire absence of serum proteids and of any free hæmoglobin which might be present if some of the corpuscles had laked. This last wash water also should give no precipitate with copper sulphate or ferric chloride. The object of these tests is to show that there is nothing in the liquid surrounding the corpuscles which will give a precipitate with the reagents.

Gower's hæmocyotometer). To definite quantities (1 c.c. and $1\frac{1}{2}$ c.c.) of this suspension, placed in very small test tubes, were added weak solutions of copper sulphate, ferric chloride, and hydrochloric acid in 0.9 per cent sodium chloride solution. These solutions were added cautiously from a capillary pipette until the corpuscles came down as a flocculent precipitate. The end-reaction is quite exactly determined, as the close agreement of the duplicate experiments will show.

TABLE I.

1 c.c. of blood-suspension required,
 Of solution of copper sulphate, 0.4 per cent 0.25 c.c.
 Duplicate experiment, copper sulphate 0.28 c.c.
 Average 0.265 c.c.

Therefore 1 c.c. blood = 0.00106 gram of copper sulphate.

1 c.c. blood required,
 Of hydrochloric acid solution, $\frac{1}{25}$ per cent 0.28 c.c.

$1\frac{1}{2}$ c.c. blood required,
 Hydrochloric acid, 0.42 c.c. = 0.28 c.c. for 1 c.c. blood
 Average 0.28 c.c.

Therefore 1 c.c. blood = 0.000112 gram of hydrochloric acid.

1 c.c. blood required,
 Of ferric chloride, 0.24 per cent 0.15 c.c.

$1\frac{1}{2}$ c.c. blood required,
 Of ferric chloride, 0.24 per cent 0.22 c.c.
 or 0.147 c.c. for 1 c.c. of blood.
 Average 0.148 c.c.

Therefore 1 c.c. blood = 0.00036 gram of ferric chloride.

Therefore 1 c.c. of a suspension of dog's corpuscles in saline, contain-
 ing 2,150,000 corpuscles to 1 c.c.,

Required for precipitation $\left\{ \begin{array}{l} 0.00106 \text{ g. of copper sulphate.} \\ 0.000112 \text{ g. of hydrochloric acid.} \\ 0.00036 \text{ g. of ferric chloride.} \end{array} \right.$

The blood in the above experiments was not diluted.
 In the following experiments a 5 to 10 per cent suspension of washed
 corpuscles or whole blood was employed.

TABLE II.

1 c.c. of whole blood took . . . 3.7 c.c. of tartaric acid (0.3 per cent).
 The washed corpuscles of 1 c.c.
 of the same blood took . . . 2.5 c.c. of tartaric acid.

TABLE II (continued).

1 c.c. of whole blood took . . .	1.2 c.c. of 0.02 per ct. hydrochloric acid.
1 c.c. " " " . . .	1.1 c.c. " " "
The corpuscles of 1 c.c. blood took (diluted to 5 c.c.) . . .	0.75 c.c. " " "
The corpuscles of 1 c.c. blood took (diluted to 5 c.c.) . . .	0.55 c.c. " " "
1 c.c. whole blood took . . .	2.9 c.c. of 0.02 per cent ferric chloride.
Corpuscles of 1 c.c., diluted to 10 c.c., took	0.25 c.c. " " "
Corpuscles of 1 c.c., diluted to 10 c.c., took	0.3 c.c. " " "

It is seen from these figures how very minute is the quantity of reagent that enters into the reaction. These results demonstrate another fact. If the reaction produced by acid salts were due to any free acid present as impurity, then one would expect that a comparatively large amount of the salts would be required to cause the precipitation. Such is not the case. It takes only three times as much of ferric chloride as it does of hydrochloric acid to cause precipitation (Table I). Now it is absurd to consider that there is thirty per cent free hydrochloric acid in Merck's ferric chloride, which would have to be the case were this reaction due to free hydrochloric acid. So without question the entire metallic salt enters into the reaction.

Having established the fact that the agglutination and precipitation is due to an effect on the blood-corpuscles themselves, the question now arises as to what part of the corpuscles is concerned in this reaction. Is it the stroma or the hæmoglobin? A very simple experiment suffices to decide this point. Whole blood or washed corpuscles are laked by any hæmolytic agent, *e. g.*, ether, water, or sapotoxin, best by a small quantity of a weak solution of sapotoxin (0.2 per cent in saline). Just enough sapotoxin should be added so that laking takes place slowly, say in three to five minutes; this leaves the precipitated ghosts well preserved. After stronger solutions of sapotoxin or water, the stromata appear considerably disintegrated. To the laked and transparent blood solution a trace of acid or any other precipitant is added. Immediately a heavy precipitate, consisting of agglutinated masses of ghosts, is thrown down.

Acids do not precipitate anything but the stromata. The metallic precipitants, however, may throw down some of the hæmoglobin at

the same time, if the solution of the blood is concentrated. The substances which do not precipitate intact blood-corpuscles, do not precipitate stromata, an exception being carbon dioxide, which precipitates ghosts, but not corpuscles.

The reaction affects the leucocytes as well as the red corpuscles. This may be seen in ordinary blood, and still better by working with a pure suspension of leucocytes. About 16 c.c. of leukæmic blood, kindly given to me by Dr. W. T. Howard, Jr., was received in a sterile test tube a few hours after the autopsy. The blood was found separated into two layers. The upper three-fourths consisted of a very yellow milky-looking serum which contained a large number of leucocytes and absolutely no red corpuscles. The lower one-fourth consisted of red corpuscles and some leucocytes. I diluted 1 cc. of the milky serum with 30 c.c. of 0.9 per cent sodium chloride solution, centrifugized and washed the sediment of leucocytes once with saline. The sediment, consisting of serum-free leucocytes, was suspended in 0.9 per cent saline, and portions were placed in very small test tubes and tested with the ordinary precipitating agents.

I found that if a mere trace of a very weak solution of ferric chloride or copper sulphate (about 0.04 per cent) was added, very striking agglutination and precipitation of the leucocytes took place. Under the microscope, clumps of agglutinated and perfectly normal-looking leucocytes were seen. The precipitate of leucocytes settled very rapidly in the test tube, leaving a clear, supernatant liquid. If a slight excess of reagent was added, the reaction did not take place, or, if it had already taken place, the clumps were broken up and the normal suspension was resumed.

With hydrochloric acid I could not at first obtain the reaction, but on repeating the experiment, using one drop of a 0.006 per cent hydrochloric acid, a typical reaction took place, the leucocytes becoming immediately agglutinated and settling rapidly to the bottom of the tube.

These experiments will show that it is a very easy matter to miss the reaction if the proper quantities of reagents are not employed. Excess of precipitating agents produces a considerable degree of leucolysis.

The investigation of the serum of this leukæmic blood gave rise to an observation which seems to show that there is an antagonism between agglutinins and hæmolysins when acting in the same serum.

The following experiment was performed:

To one part of a 10 per cent suspension of washed dog's corpuscles was added an equal part of the leukæmic serum. A very feeble attempt at agglutination occurred, but this was so slight that on preparing a microscopic specimen the agglutination was completely broken up by the mere act of placing the cover slip on the drop of blood. The blood was not at all precipitated in the test tube. *The blood-corpuscles laked rapidly*, in five minutes, first exhibiting considerable swelling, just as occurs when corpuscles precipitated by acids and acid salts are allowed to remain at room temperature.

Thinking that the presence of the hæmolysin in the leukæmic serum interfered with the action of the agglutinin, I made the following experiment :

To the same washed dog's corpuscles was added an equal portion of the serum from another dog. No agglutination or precipitation of the corpuscles occurred. To this mixture (equal parts $\frac{1}{2}$ c.c.) were added two drops of the leukæmic serum. There was immediately a good agglutination and precipitation of all the blood-corpuscles, which settled completely in five minutes. After twenty-four hours, absolutely no laking of the precipitated corpuscles had taken place. Apparently the second dog's serum contained an antihæmolysin which protected the corpuscles of the first dog from the action of the hæmolysin contained in the leukæmic serum. As soon as the latter hæmolysin was neutralized, the agglutinin of the leukæmic serum had free play and produced a marked agglutination of the dog's corpuscles.

To two drops of leukæmic blood in 1 c.c. of saline was added one drop of ferric chloride. A fairly good agglutination of the corpuscles occurred. On the slide this agglutination was completely broken up by the pressure of the cover slip. The corpuscles appeared enormously swollen. In the test tube at the same time the corpuscles were beginning to resume normal suspension, the agglutination becoming broken up. One more drop of ferric chloride was added. A heavy flocculent precipitate of corpuscles came down, the corpuscles having resumed approximately normal size. The precipitate settled in a minute, leaving a perfectly clear and colorless supernatant liquid, showing no trace of laking. The lesson I would draw from this experiment is that the condition of the blood-corpuscles *when they are swelled* is antagonistic to their agglutination. This is seen also in the first experiment, where the hæmolysin of the leukæmic serum also produced swelling of the dog's corpuscles, and the agglutination of the corpuscles was almost entirely prevented. As soon as the effect of the hæmolysin on the corpuscles was removed, then the agglutination took place readily.

To one part of a 10 per cent suspension of my own blood in 0.9 per cent saline was added one part of the leukæmic serum. A good agglutination and precipitation of the corpuscles occurred. After twenty minutes, one-

half part of leukæmic serum was added. Laking started soon after and in an hour was almost complete.

Red corpuscles and leucocytes are not the only cells affected by the reaction. It seems to be a very general one, being given by all the cells which I have hitherto tested — namely, spermatozoa, ciliated epithelium, yeast cells, a fungus, and a bacillus.

Human spermatic fluid, possessing a strongly alkaline reaction, was suspended in saline. To this a little ferric chloride solution was added. A precipitate came down consisting of masses of fine granules. On the further addition of ferric chloride, a flocculent precipitate appeared consisting of agglutinated masses of spermatozoa surrounded by the granular precipitate already mentioned. If the spermatic fluid was neutralized with hydrochloric acid before the ferric chloride was added, then practically no granular precipitate was thrown down, but the spermatozoa alone were immediately agglutinated and came down as a flocculent precipitate. Under the microscope the spermatozoa were seen in clumps, a tangle of heads and tails, the motility of the spermatozoa being completely suppressed. Around these agglutinated masses of spermatozoa and in their midst were seen masses of the granular material that is present normally in spermatic fluid (detritus of spermatozoa, spermatic corpuscles, etc.).

Human spermatic fluid, diluted with saline, was treated to fractional centrifugalization, so that the first sediment contained principally the granular material, spermatic corpuscles, etc., while the supernatant fluid contained practically nothing but spermatozoa. This supernatant fluid was centrifugalized, and the sediment, consisting almost entirely of spermatozoa, was washed with saline, and again centrifugalized. The sediment of spermatozoa thus obtained was suspended in 0.9 per cent saline, and treated with various precipitants.

Ferric chloride caused a marked agglutination and precipitation of the spermatozoa. I could not obtain the reaction with either hydrochloric acid or copper sulphate; possibly I worked with too large amounts of these reagents.

If uranium acetate is added to spermatic fluid suspended in saline, a heavy precipitate is thrown down. Under the microscope, it is seen that but very few of the spermatozoa have been caught and carried down by the precipitate. They retain their motility and lie free in the liquid. If the bulky precipitate produced by the uranium acetate is allowed to settle, the supernatant liquid containing most of the spermatozoa decanted, and to this fluid a drop of ferric chloride is added, all the spermatozoa are immediately agglutinated and precipitated, showing conclusively that

this is a specific reaction and is not caused by any extraneous precipitate carrying down the spermatozoa.

- Ciliated epithelium obtained by scraping the laryngeal mucosa of a rabbit was suspended in saline, and any blood present laked by a little sapotoxin. Ferric chloride gave a good agglutination and precipitation of the epithelial cells. I could not obtain the reaction with hydrochloric acid or copper sulphate.
- A piece of ordinary cake of dried yeast was rubbed up with 0.9 per cent sodium chloride solution, so that under the microscope the yeast cells were seen to lie separately, absolutely no clumps of cells being visible. The cells were immediately agglutinated and precipitated in flocculent form by a little ferric chloride. This precipitate consisted of agglutinated masses of well-preserved, normal-looking yeast cells, no extraneous precipitate being visible. Centrifugalized and washed yeast cells (*i. e.*, washed with saline) gave the same reaction.
- A small quantity of a mould was shaken up with saline. Under the microscope, mycelia and spores were seen, but no clumps to speak of. To this suspension a trace of ferric chloride was added. A flocculent precipitate was thrown down, consisting of agglutinated masses of mycelia and spores.
- A strong solution of peptone was inoculated with a motile bacillus. After several days the solution was centrifugalized and a heavy sediment consisting entirely of bacilli was obtained. It was almost a pure culture of a short, very motile bacillus. This sediment was washed and recentrifugalized until free from the peptone solution. The bacilli were then shaken up in saline until all clumps of bacilli were broken up. Ferric chloride as well as hydrochloric acid caused the bacilli to lose their motility and immediately to become agglutinated and precipitated.

USES AND APPLICATIONS OF THE REACTION.

This reaction may be put to the following uses:

1. To obtain large quantities of blood-corpuscles.

For this purpose the following procedure is recommended.

All the operations are best done with the temperature of the solutions kept as near as possible to 0° C.

Fresh defibrinated dog's blood is diluted with ten parts of 0.9 per cent saline and the beaker with this mixture is cooled to 0° C. Then, with constant stirring, a solution of 0.2 per cent hydrochloric acid in saline, or of 1.2 per cent ferric chloride in saline, is allowed to drop into the mixture from a burette. For every 5 c.c. of dog's blood, 5 to 10 c.c. of the hydrochloric acid or 1.7 to 1.8 c.c. of the ferric chloride solution are

required. The corpuscles are rapidly precipitated and settle well, leaving a perfectly clear supernatant liquid, when hydrochloric acid is used as precipitant, while a slight amount of a granular precipitate is produced in the supernatant liquid if ferric chloride is employed. This granular precipitate consists of a globulin.

The supernatant liquid is then decanted, and the corpuscles are transferred to centrifuge tubes and quickly centrifugalized (for about two or three minutes). The supernatant liquid is then decanted or otherwise removed, ice-cold saline is added to the corpuscles in the tubes, the latter are well shaken up, and then once more centrifugalized. This washing and centrifugalization is repeated three or four times. After being thoroughly washed, the corpuscles may be suspended in saline, and may then remain at room temperature for many hours without the slightest laking.

The granular precipitate produced by ferric chloride is removed in large part by the washings, which floats the precipitate off. Its presence may be avoided by using a mixture of ferric chloride and acids in precipitating, or by using a less proportion of ferric chloride than is given above.

If quantitative experiments are intended, then it is best to place the measured blood from the first in the centrifuge tubes, diluting with ten volumes of saline, and adding the proportionate amounts of reagent.

Ferric chloride is to be preferred as a precipitant, since hydrochloric acid has a great tendency to cause laking. By this process a large amount of blood-corpuscles, thoroughly free from serum, may be obtained in less than half an hour.

2. To interrupt the action of all those hæmolytic agents which are not affected by the precipitants. For instance, it is desired to know if sapotoxin is fixed by blood-corpuscles after acting on them for a certain length of time and at a definite temperature. After the desired length of time has elapsed the blood is cooled to 0° , which, I have found, arrests the action of the sapotoxin. The blood is then diluted a little with ice-cold saline solution, the corpuscles precipitated by hydrochloric acid or ferric chloride, and rapidly centrifugalized. The corpuscles are thus very quickly removed from the action of the sapotoxin, especially if the whole experiment be performed in centrifuge tubes. The supernatant liquid will then show if any laking has taken place, and the sediment of corpuscles, which may be washed with cold saline solution if desired, is allowed to stand suspended in saline. If the corpuscles lake, sapotoxin has been fixed.

3. To determine at any given moment what percentage of corpuscles has been laked by a hæmolytic agent. At the desired moment

the corpuscles are precipitated and the amount of free hæmoglobin in the supernatant liquid (which is obtained by centrifugalization) is determined colorimetrically.

4. This reaction might perhaps be used for determining the alkalinity of the blood-serum. It is evident that there is a close connection between agglutination and precipitation of the corpuscles and the alkalinity of the blood. The serum remaining after the corpuscles are exactly precipitated, is perfectly neutral in reaction. It is possible that the point where the corpuscles just begin to agglutinate is an indication that the alkalinity of the serum is neutralized.

EXPLANATION OF THE REACTION.

It has been shown above that the stromata are precipitated by the same reagents which precipitate and agglutinate intact blood-corpuscles. Therefore the substance which combines with the precipitating agent must be a constituent of the stromata. According to Halliburton,¹ "cell globulin β " is the principal proteid demonstrable in the stromata of red corpuscles, and this proteid seems to be common to leucocytes, liver cells, and apparently all typical cells. Later researches² have shown that this cytoglobulin is really a nucleoproteid. The nucleoproteids of blood-corpuscles, like the globulin of the serum, act like weak acids, and must be considered as existing in combination with alkalis.³ The other constituents of the stromata were found by Woolridge to be lecithin and cholesterin.

That the cholesterin and lecithin are not concerned in this reaction is shown by the fact that in ether-laked blood, where the cholesterin and lecithin are dissolved out from the stromata, the precipitation still occurs on addition of the reagents. We must, therefore, look to the proteid of the stroma for an explanation of the reaction. How does this substance react toward the acids and acid salts which produce agglutination and precipitation of blood-corpuscles? Nucleoproteids combine with alkalis to form neutral or slightly acid solutions. From these solutions the nucleoproteid is precipitated by small quantities of most acids and acid salts.

It seems probable therefore that the agglutination and precipitation of the red blood-corpuscles by acids and acid salts is due to a combination of the latter with the nucleoproteid of the stromata.

¹ HALLIBURTON and FRIEND: *Journal of physiology*, x, p. 537.

² HALLIBURTON: *Journal of physiology*, 1895, xviii, p. 306.

³ C/. HAMMARSTEN: *Physiologische Chemie*, p. 80.

That acid salts form an actual combination with nucleoproteid is seen from the fact that the smallest quantities of these salts form a precipitate in a neutral solution of the former.

Why certain acids and acid salts will not precipitate intact corpuscles and stromata, I cannot at present say. The reason of the inactivity of some of these substances probably lies in the fact that they are unable to precipitate nucleoproteids. For instance, I found that potassium acid tartrate, potassium and antimony tartrate, and calcium glycerino phosphate were unable to form a precipitate in a solution of sodium caseinate (casein being a typical nucleoalbumin). To explain the inactivity of other substances a clue may perhaps be found in the observation that at least some of the acids and acid salts which do not agglutinate and precipitate corpuscles and stromata are found in certain strengths to produce crenation of the corpuscles. This fact is well shown by arsenious and boracic acids. Those acids and acid salts which do agglutinate and precipitate corpuscles were never seen by the writer to cause crenation, but always produced a rounding and filling out of the contours of the corpuscles, even if they were previously crenated. This indicates that the active reagents penetrate the corpuscles readily, while the inactive ones penetrate imperfectly.

The question arises: how far do the precipitating agents penetrate into the corpuscles when they are added in just sufficient amounts to cause agglutination and precipitation? I believe that the reagents do not penetrate more than a slight distance, but remain close to the surface and combine with the surface layer or envelope of the corpuscles. The envelope becomes sticky, thus accounting for the agglutination. The corpuscles increase in weight, owing to the entrance of the reagent, and are therefore precipitated.

My reasons for supposing that the reagents combine with the surface layer of the corpuscles, and do not penetrate for more than a slight depth, are the following:

1. The quantity of reagent needed to produce agglutination and precipitation is very slight. If complete penetration of the corpuscles occurred, it is evident that all the alkali contained in the corpuscles would have to be neutralized. This would require much more reagent than is really necessary for precipitation.

2. The fact that repeated washing of precipitated corpuscles restores in large part their normal suspension; also the fact that excess of reagent outside the corpuscles prevents agglutination and

precipitation. In the first case we must assume that the normal alkalinity of the surface layer or envelope has been to a great degree restored. In the latter case, the excessive acidity of the surface layer seems to prevent precipitation. Both these instances tend to show that the reaction of the *surface layer* of the corpuscles (*i. e.*, the reaction toward litmus) is an important factor in their agglutination and precipitation.

3. The hæmoglobin contained in the corpuscles is not altered in the least, if only the exact amount of reagent necessary to agglutinate and precipitate the corpuscles is employed. Yet all the precipitating agents, acids and acid salts, in dilute solution convert oxyhæmoglobin, first, into methæmoglobin, and then into acid hæmatin.

If moderate excess of reagent be added, then the corpuscles will still be precipitated, but no methæmoglobin band appears for five or ten minutes, depending on the amount of reagent employed. *The same amount of reagent added to the same amount of sapotoxin or water-laked blood instantly converts part of the oxyhæmoglobin into methæmoglobin and this conversion proceeds very rapidly till complete.*

The following experiments may be quoted :

1. 1 c.c. of blood, diluted to 10 c.c. with saline, required 0.4 c.c. of ferric chloride solution (12 grams of ferric chloride to 1 litre of 0.9 per cent saline) in order that the corpuscles should be agglutinated and precipitated. The spectrum of the precipitated blood was that of oxyhæmoglobin, and it remained so for several hours.
2. To 1 c.c. of the sapotoxin laked blood, diluted to 10 c.c. with saline, was added 0.4 c.c. of ferric chloride. The ghosts were precipitated; no methæmoglobin was formed.
3. To 1 c.c. of blood, diluted to 10 c.c. with saline, added was 2 c.c. of ferric chloride, a considerable excess over the required amount (0.4 c.c.) of reagent. The corpuscles were precipitated. I watched with the spectro-scope for the methæmoglobin band. The latter did not appear until eight minutes had elapsed. The corpuscles at the same time turned dark and started to lake.
4. To 1 c.c. of sapotoxin laked blood, diluted to 10 c.c. with saline, was added 2 c.c. of ferric chloride. The methæmoglobin band appeared instantly, and quickly became very strong. The color of the solution turned dark.
5. To 5 c.c. of ferric chloride, diluted to 10 c.c. with saline, was added $\frac{1}{2}$ c.c. of blood (therefore a large excess of reagent). The corpuscles were precipitated. The methæmoglobin band did not appear until five minutes

after the blood was mixed with the reagent. The blood then began to turn dark and to lake.

6. To 1 c.c. blood, laked with water and diluted with water to 10 c.c., was added 0.4 c.c. of ferric chloride. The stromata were all agglutinated and precipitated, while the color of the solution remained bright red and showed only oxyhæmoglobin bands and no methæmoglobin. Then 1.6 c.c. more of ferric chloride was added. Immediately a methæmoglobin band appeared and the blood turned dark brown. This seems to show that the reagents combine first with the stromata, and only after more than enough has been added to precipitate the stromata is the hæmoglobin attacked. In other words, the stromata protect the hæmoglobin from the action of a certain amount of reagent.

From the above experiments it is evident that in the intact corpuscles the protection of the oxyhæmoglobin is much more complete than in laked blood. This protection against the action of reagents, if it is of a chemical nature, might be afforded by: (1) the alkali of the corpuscles; (2) the stroma substance; (3) the firm combination of the hæmoglobin with the stroma.

That neither the alkali nor the stroma substance shields the hæmoglobin from the action of the reagents is shown by the fact that after laking the presence of stromata and of liberated alkalies protects oxyhæmoglobin but slightly, and not at all if excess of the reagent be present (compare Experiments 1-6). Moreover there are many facts which suggest that the hæmoglobin compound within the corpuscles is in all probability a weak one. So that it seems most likely that there is something in the structure of the corpuscles, some mechanical barrier, which shields the hæmoglobin from the immediate action of the reagents, in other words, an envelope.

In using the term envelope I merely suggest that at the surface of the corpuscle there exists a hæmoglobin-free layer of stroma, but not necessarily a differentiated membrane. In order to explain all the known facts, this envelope must be supposed to contain nucleoproteid, chlosterin, and lecithin.

That the hæmoglobin of mammalian corpuscles does not extend to the very periphery, but is separated from the latter by a thin hæmoglobin-free layer, seems probable from the results obtained by means of a reaction in which, by the addition of hydroxylamine hydrochlorate to blood, bubbles of gas are caused to form just within the periphery of the corpuscles. These bubbles are lined externally by a delicate membrane (*a*, Fig. 1) and internally by hæmoglobin (*b*).

The membrane is hardly stained by any of those dyes which stain the hæmoglobin in the rest of the corpuscles very deeply. This indicates that it does not contain hæmoglobin. It appears colorless in the unstained corpuscle. This might be because the color of a very thin layer of hæmoglobin might escape detection.



Fig. 1

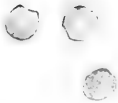

Fig. 2

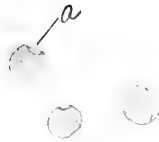

Fig. 3

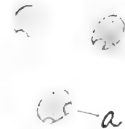

Fig. 4

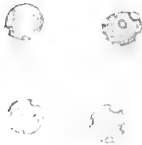

Fig. 5



Fig. 6



Fig. 7

Figures showing bubble formation in blood-corpuscles treated with hydroxylamine hydrochlorate.

Only by observing the corpuscles during the formative stage of the bubbles is it possible to make out that they are not formed within the hæmoglobin at all, but that the latter merely forms their inner boundary.

About ten minutes after the reagent and blood are mixed, the first sign of the intracorpuseular bubble formation becomes evident; it consists in a flattening or depression of the hæmoglobin on the periphery of a corpuscle, the outer lining of the bubble being too close to the hæmoglobin at this stage to be visible (Fig. 2).

The next stage is represented by Fig. 3, and shows some separation between the surface layer of the corpuscle (*a*) and the hæmoglobin. The completed bubble appears in Fig. 4, the outer lining (*a*) often projecting considerably above the surface.

The most striking part of the reaction lies in the depression of the hæmoglobin from the surface of the corpuscles in the first stage. It demonstrates that the accumulation of gas takes place between an enveloping layer and the hæmoglobin, causing the repulsion of the latter from surface of the corpuscle toward the centre and at the same time separating the envelope from the hæmoglobin underneath. Although gas is formed immediately on mixing the reagents, yet about ten minutes elapse before bubbles are formed inside of the corpuscles. This could be explained on the hypothesis that the envelope must be hardened to a certain extent before it will be sufficiently unyielding to retain the bubbles within the corpuscles.

Occasionally a burst bubble is noted, the lining of which is seen as in Fig. 6. In order that others may be able to verify these statements, I shall give a detailed account of the procedure by which the above results were obtained.

The reagent is a saturated solution of hydroxylamine hydrochlorate in 0.9 per cent saline solution. I usually prepare this solution just before use, as the temperature of a freshly prepared solution is much lower than the temperature of the room, and this may have some bearing on the obtaining of a successful result.

The blood used was defibrinated dog's blood, although human blood also showed good intracorpuseular bubble formation.

To one part of blood in a test tube is added an exactly equal part of the reagent, and the tube is quickly shaken to insure intimate mixture. The color of the blood turns dark brown almost immediately. Bubbles of gas quickly begin to rise to the surface, and soon the mixture becomes so full of bubbles as to be almost solid, owing to their presence. Under the microscope, the corpuscles appear somewhat swelled, but the outlines are for the most part smooth. Only after ten minutes does intracorpuseular bubble formation become evident. After a few hours this is complete.

If examined after twenty-four hours, the hydroxylamine corpuscles are found to be thoroughly hardened, so that neither sapotoxin, water, acids, nor alkalis will cause the slightest laking, although the last three cause great swelling of the corpuscles. The bubbles are especially well brought out by adding a drop or two of ammonia (10 per cent) to some corpuscles on a slide. A trace of methylene blue or gentian violet or methyl green, added after the ammonia, brings out in striking contrast the practically unstained bubble lining and the deeply stained corpuscles.

In a successful specimen most of the corpuscles should contain one or more bubbles. Many contain a whole peripheral ring of bubbles (Fig. 5).

Efforts were unsuccessfully made to produce a differential stain of the membrane-like film covering the bubbles.

The exact proportion and method of mixing given above must be used. If less of the reagent is employed, then the corpuscles will appear laked, the hæmoglobin being precipitated in the form of granules on top of and around them. Hydroxylamine hydrochlorate precipitates hæmoglobin completely from solution. If more than the proper proportion of reagent is used, then the corpuscles show absolutely no intracorpuseular bubble formation, although gas comes off from the liquid. The age of the blood is a very important factor in the success of the reaction. With perfectly fresh defibrinated dog's blood a comparatively slight amount of intracorpuseular bubble formation took place. The same blood, when thirty hours old, was treated with the reagent, and in the majority of corpuscles one or more bubbles were formed. This blood, when sixty hours old (having been kept in the ice-chest in a beaker covered with filter paper), was still of a bright red color (therefore not reduced), and gave rise to a considerable number of bubble corpuscles when hydroxylamine hydrochlorate was added.

The blood was then placed on ice in a stoppered test tube. After twelve hours it was still bright red. The blood was then treated with hydroxylamine hydrochlorate, and almost no bubbles were formed. The corpuscles, after the addition of the reagent, looked riddled, as though a large number of bubbles had escaped from the corpuscles and had left holes in them or their envelopes, as in Fig. 7.

Evidently some great change had occurred in the corpuscles during the last twelve hours. Before this time many bubbles were retained within the corpuscles after treatment with the reagent. Twelve hours later the corpuscles were unable to retain any gas bubbles whatever. This is easily explainable, on the hypothesis that the envelopes of the corpuscles had deteriorated and had become weaker during those few hours, so that a too rapid penetration of the corpuscles by the reagent took place, giving rise to a sudden and great evolution of gas bubbles which the weakened envelopes were unable to retain; as the envelope hardened simultaneously with the escape of the bubbles, the rents in the former remained permanently open, thus giving rise to the perforated appearance.

Blood six days old, kept stoppered on ice, and whose hæmoglobin appeared to be thoroughly reduced, yielded no intracorpuseular bubbles, although a large amount of gas was given off, the corpuscles having the riddled appearance mentioned above. Through this blood oxygen was passed. On the addition of hydroxylamine hydrochlorate less gas was given off, but no intracorpuseular bubble formation took place. Illuminating gas was then passed through this blood: also no intraglobular bubble formation on addition of the reagent.

Ordinary fresh blood, mixed with equal parts of hydroxylamine hydrochlorate solution, was placed in a thick-walled test tube which was connected with a suction pump. Bubbles formed in the corpuscles just as usual, the suction having failed to remove them from the corpuscles.

I was unsuccessful in modifying the usual result by carrying out the reaction under pressure. Fresh blood, mixed with equal parts of reagent, was exposed to considerable air pressure, which was released after a few minutes; no unusual effect was produced in the corpuscles.

If laked blood is treated with a little hydroxylamine hydrochlorate, the stromata, together with the hæmoglobin, are precipitated.

In attempting to determine the source of the gas, the following experiment was made:

Dog's serum mixed with an equal part of the hydroxylamine hydrochlorate solution gave off practically no gas. On adding to this mixture a little blood from the same dog, a large amount of gas was evolved and the test tube became warm. This shows that the gas is formed entirely by the interaction of the corpuscles and the reagent.

What does this gas consist of and how is it generated?

Hydroxylamine hydrochlorate is strongly acid in reaction, therefore it seems probable that some carbon dioxide is driven off from the corpuscles by the reagent. Moreover hydroxylamine hydrochlorate is easily decomposed, giving off nitrogen gas. Also if a saturated solution of hydroxylamine hydrochlorate is treated with a little caustic soda, nitrogen is evolved. Does the reaction take place between the oxygen of the oxyhæmoglobin and the hydroxylamine? Or between the alkali of the corpuscles and the reagent? Or is the reaction due to a catalytic action on the hydroxylamine produced by some substance of the stroma? Experiments are being made to determine these points.

An analysis of the gas given off in the above reaction was made as follows:

In a test tube was poured 8-10 c.c. of mercury, and upon this 15.5 c.c. of blood. Then 4 c.c. of a saturated solution of the reagent was added, this being just enough to fill the tube perfectly. The few bubbles on top of the liquid were quickly removed with filter paper, the test tube closed with the finger, inverted, and placed over mercury. Gas began to form immediately. After twelve hours the mixture of blood and reagent was almost solid, and contained bubbles throughout its whole extent. The tube was then placed in a large dish containing water, then an aluminium probe, around the end of which was wrapped a small piece of cotton which had been wetted to remove air, was passed inside of the test tube and worked up and down, the tube being kept quite vertical throughout this procedure. The bubbles were thus released and rose to the top, while the other contents of the tube were washed out by the surrounding water.

After all the blood and reagent were removed from the tube, and the gas had all collected at the top, the test tube was again placed over mercury. By suitable means, most of the water in the tube was removed and mercury drawn up in its place. Caustic soda solution was then introduced by means of a pipette with a recurved tip. Some of the gas was absorbed = carbon dioxide. Then a strong pyrogallic acid solution was allowed to enter, and the tube was agitated. More gas was absorbed = oxygen. The greater part of the gas remained unabsorbed after six hours = nitrogen. I assume this residue to be nitrogen, because it is the only inert gas which could be given off in this reaction.

Roughly the following measurements were obtained :

15.5 c.c. of blood, mixed with 4 c.c. of a saturated solution of hydroxylamine hydrochlorate, gave rise to 5 c.c. of gas which consisted of

3.6 c.c. nitrogen,
0.8 c.c. oxygen,
0.6 c.c. carbon dioxide.

It is evident that only a small part of the oxygen in the blood was given off. What became of the remainder? If we assume that it combined with the reagent after the following reaction :

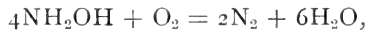

then we would expect to find two volumes of nitrogen given off for every volume of oxygen fixed. This is approximately what was found to be the case in the rough quantitative experiment detailed above. However, more experiments, exactly performed, will be required to determine what actually takes place during the interaction of the reagent and blood-corpuscles.

The behavior of corpuscles of various ages towards hydroxylamine hydrochlorate, as well as their behavior toward various strengths of the latter reagent, speaks strongly for the presence of an envelope.¹ Evidence has already been found that the surface layer of the corpuscles consists in part of nucleoproteid. It seems also to contain cholesterin, and probably lecithin, for reasons which will be given, elsewhere, in a conjoint paper by Dr. G. N. Stewart and myself.

CONCLUSIONS.

As most of the conclusions of this paper were summarized in a preliminary note in a previous issue of this Journal (Volume VIII,

¹ H. DEETJEN (in VIRCHOW'S Archiv für experimentelle Pathologie, 1901, clxv, p. 232) gives a staining reaction whereby, according to him, the envelopes of red corpuscles are easily made apparent; I have not seen his statement either corroborated or refuted.

page 99), I shall content myself by giving here only those which were not stated therein.

1. The precipitating agents do not penetrate far into the corpuscle during the reaction, but remain close to the surface and combine with the surface layer.

2. Theoretical considerations, as well as chemical and histological facts brought out in this paper, render the existence of an envelope in mammalian blood-corpuscles highly probable, if not absolutely certain. To explain all the facts, such an envelope must be assumed to contain nucleoproteid, cholesterin, and lecithin.

Since leucocytes and probably all typical cells possess the above-mentioned constituents, it seems likely that these substances serve the same purpose in the structure of all these cells, — namely, that of forming an envelope.

In conclusion I wish to express my thanks to Dr. G. N. Stewart for the kind interest he has taken in my work, and for the many valuable suggestions that I have received from him.

HOW LONG DOES (ARBACIA) SPERM LIVE IN SEA-WATER?

By MARTIN H. FISCHER.

[From the *Physiological Laboratory of the University of California.*]

IN the course of our experiments at Wood's Holl, two questions had often arisen: first, How long after removing the sperm from the testicles of a marine animal do the spermatozoa retain their power of fertilization if kept in sea-water; and secondly, if fertilization occurs when the spermatozoa are dying, will the fertilized eggs develop into adult animals or only pass through the first few stages of segmentation? It was with a view to answering these questions that, at the suggestion of Dr. Loeb, I undertook the following experiments upon sea-urchins (*Arbacia*).

It has been a generally accepted fact that the sperm of marine animals lives but a few hours after being shed into sea-water. Gemmill,¹ for example, found that the spermatozoa of sea-urchins live comparatively few hours after being shed into sea-water. When small amounts of sperm are added to large amounts of sea-water, they live from three to five hours; if concentrated solutions of the sperm are made in sea-water (one of sperm to ten of sea-water) they at times live as long as seventy-two hours. That he obtained no better results is probably due to his failure to observe any aseptic precautions in his experiments. That the spermatozoa do not live as long in a large amount of sea-water as in a small amount, Gemmill attributes (1) to the "stimulating" effects of the sea-water upon the movements of the spermatozoa, and (2) to a dilution of the spermatogenic fluid which is supposed to possess nutritive properties. The rôle of bacterial development, the surface action of the glass, the increased viscosity of the sea-water when a large amount of sperm is added, the lack of oxygen, etc., are entirely neglected.

All who have worked with the sperm of sea animals know that when it is kept in a dish of sea-water under ordinary conditions, it is

¹ GEMMILL: *Journal of anatomy and physiology*, 1900, xxxiv, p. 163.

not long before the whole is converted into an ill-smelling, putrid mass, having no powers of fertilization. A large number of spermatozoa die soon after their removal from the animal body, and these, together with the blood and débris which may accidentally have been introduced into the dish containing the sperm, form an excellent culture ground for bacteria. The poisonous products formed by the bacteria soon end the life of the spermatozoa that may at first have survived.

In all the experiments described in this paper the following general methods were followed. The male sea-urchins after having been kept in running sea-water for some time were scrubbed for several minutes in running fresh water. They were then laid upon their backs and allowed to drain, while the experimenter carefully washed his hands in fresh water and sterilized by heat all the instruments that were to come in contact with the animal. The ventral surface of the sea-urchin was then removed with sterile scissors, and the abdominal cavity exposed. The testicles were removed with sterile forceps, washed in boiled sea-water contained in sterilized finger bowls to remove any blood or débris that might adhere to them, and transferred to a second sterilized finger bowl containing sterile sea-water. The sperm issues from the testicles in a dense, syrupy cloud. This I removed with sterile pipettes to sterile flasks containing sterile sea-water and stoppered with sterile cotton plugs.

Only sea-water sterilized by bringing it to the boiling point and then allowing it to cool off slowly in cotton-stoppered flasks was used in the experiments. To recharge it with oxygen, it was thoroughly shaken in the air. All the glassware used in the experiments was sterilized in an Arnold steam sterilizer for two or more hours. The flasks used for keeping the sperm after removal from the body were stoppered with cotton. The steel instruments were sterilized by dry heat.

The fertilizing power of the sperm at the beginning and during the course of the experiments was tested by adding the sperm to freshly obtained sea-urchin eggs. The eggs were obtained with the same careful precautions with regard to asepsis and to the possibility of infection with sperm which were adopted in the method for obtaining the spermatozoa in a sterile condition. A control experiment in each case served as a check upon the result obtained. The fertilizing power of the sperm was tested every few hours, until segmentation no longer followed the addition of the sperm to the eggs. Fresh eggs, capable of being fertilized — as shown by adding fresh sperm

to them—were used in every instance. When a negative result was obtained, the test was repeated two or three times to corroborate the result. In each case the last successful fertilization was taken to indicate the end of the experiment.

The following is a synopsis of the experiments performed :

Experiment I, July 6, 1902. — 9.35 P. M. Removed sperm from the testicles of two sea-urchins, and kept it in two 250 c.c. Florentine flasks, half full of sea-water. Last successful fertilization July 9, 1902, 5.00 P. M.

Time : 67 hrs., 25 min.

Experiment II, July 7, 1902. — 9.30 A. M. Removed sperm from the testicles of one sea-urchin, and kept it in one 500 c.c. Florentine flask, half full of sea-water. Last successful fertilization July 9, 1902, 5.00 P. M.

Time : 55 hrs., 30 min.

Experiment III, July 7, 1902. — 3.10 P. M. Sperm from one sea-urchin was kept in one 250 c.c. Erlenmeyer flask containing 100 c.c. of sea-water. Last successful fertilization July 10, 1902, 5.00 P. M.

Time : 73 hrs., 50 min.

Experiment IV, July 7, 1902. — 5.45 P. M. Sperm from one sea-urchin was kept in two 250 c.c. Erlenmeyer flasks, each containing 100 c.c. of sea-water. Last successful fertilization July 12, 1902, 7.00 P. M.

Time : 121 hrs., 15 min.

Experiment V, July 12, 1902. — 5.00 P. M. Removed sperm from testicles of three sea-urchins, and distributed it in varying amounts into ten 50 c.c. Erlenmeyer flasks, each containing 20 c.c. of sea-water. Last successful fertilization July 15, 1902, 12.00 noon.

Time : 67 hrs.

Experiment VI, July 17, 1902. — 10.00 A. M. Removed sperm from the testicles of three sea-urchins, and distributed it into ten 50 c.c. Erlenmeyer flasks, each containing 25 c.c. sea-water. Last successful fertilization July 18, 1902, 10.15 A. M.

Time : 24 hrs., 15 min.

Experiment VII, July 18, 1902. — 9.30 A. M. Removed sperm from one male sea-urchin, and distributed it into ten 50 c.c. Erlenmeyer flasks, containing from 15–30 c.c. sea-water. I was compelled to leave Wood's Holl, before the completion of this experiment. I still obtained blastulæ from a dish of eggs fertilized July 23, 1902, 11.00 P. M.

Time : at least 133 hrs., 30 min.

Experiment VIII, July 19, 1902. — 11.30 A. M. Removed the sperm from one sea-urchin, and kept it in ten Erlenmeyer flasks. Last successful fertilization July 21, 1902, 3.00 P. M.

Time : 27 hrs., 30 min.

Experiment IX, July 20, 1902. — 10.00 A. M. Removed the sperm from one sea-urchin, and distributed it into five Erlenmeyer flasks. Last successful fertilization July 21, 1902, 10.00 A. M.

Time: 24 hrs.

Experiment X, July 20, 1902. — 11.20 P. M. Removed sperm from one sea-urchin, and distributed it into five Erlenmeyer flasks. Last successful fertilization July 23, 1902, 11.00 A. M.

Time: 59 hrs., 40 min.

Experiment XI, July 21, 1902. — 10.15 A. M. Distributed sperm from one male into five Erlenmeyer flasks. Last successful fertilization July 23, 1902, 11.00 A. M.

Time: 48 hrs., 45 min.

Experiment XII, July 21, 1902. — 2.45 P. M. Distributed sperm from one male into five Erlenmeyer flasks. I was compelled to leave Wood's Holl before the completion of this experiment. I still obtained blastulae from a dish of eggs fertilized July 23, 1902, 11.00 P. M.

Time: at least 56 hrs., 15 min.

Sufficient sperm was put into each of the flasks to give them a milky color, and the flask was always shaken to distribute the spermatozoa evenly through the sea-water. Within certain limits, the amount of sperm did not, however, affect the general result. I thought that a large amount of sperm in a small amount of sea-water might easily suffer from a lack of oxygen, but even when enough sperm was added to the sea-water to make it distinctly white in color, the result was quite as good as when these conditions were reversed. When a very small amount of sperm is used, it is soon precipitated on the sides and bottom of the glass vessel. We seem to deal here with a surface action of the glass.

The spermatozoa sometimes die very suddenly, and at other times more slowly. When the latter occurs, equal quantities of sperm — as measured with the pipette — from the same flask will fertilize a less and less number of eggs, as time goes on.

The above experiments show that the spermatozoa of the sea-urchin (*Arbacia*) live from forty-eight to at least one hundred thirty-three and a half hours after being shed into sea-water. What determines these individual differences is reserved for further study.

In answer to the second question raised above, it must be said that whenever fertilization occurs the fertilized egg develops to the adult stage. In all the experiments described above the test dishes were kept for several days, and never was a segmented egg found

that did not develop into a pluteus. Several times the developing eggs were traced through every stage of their segmentation, the sperm being tested at intervals of one hour, but never was a different result obtained. In only one instance (Exp. VIII) did I find a number of irregularly segmented and dead eggs in one of the test dishes beside the swimming blastulæ. In the former the pigment was collected in the centre of the eggs, and I feel confident that some foreign matter (probably iron from the steam sterilizer) got into the dish and poisoned the eggs.

The spermatozoa seem to retain their power of fertilization as long as they retain their power of ciliary motion. In every case in which I was able to fertilize eggs, actively moving spermatozoa were found; and I did not find motile spermatozoa in sperm that could no longer fertilize, even though the heads were still intact. These facts would seem to indicate that the essential function of the spermatozoon in fertilization is to carry something into the egg that leads to the successive changes in it which are termed development.

VARIATIONS IN THE AMPLITUDE OF THE CONTRACTIONS OF HUMAN VOLUNTARY MUSCLE IN RESPONSE TO GRADED VARIATIONS IN THE STRENGTH OF THE INDUCED SHOCK.

BY THOMAS ANDREW STOREY.

[*From the Physiological Laboratory of Stanford University.*]

IN dealing with the electrical excitation of human voluntary muscle, one of the first points to be decided is where to place the secondary coil in its relation to the primary coil in order to gain the most efficient strength of the induced shock. One finds, on looking over the literature bearing upon the influence of electrical excitation upon the contraction of voluntary muscle, that this problem has usually been met by simply using the strongest current that could be endured. The secondary coil has been placed as far over the primary as the pain produced by the induced current would permit.

The writer noticed in an earlier set of experiments that he got better contractions from human voluntary muscles with a strength of the single induced shock that was not painful. That experience led to the investigation upon which this paper is based.

APPARATUS.

The myograms obtained in these experiments were made with an ergograph devised by the writer in the Physiological Laboratory of the University of Michigan in 1900. The ergograph and its manipulation have been described elsewhere.¹

An electric pendulum was used for the control of the primary current. It was so arranged as to make it possible to cut out either the make or the break shock. The keys were platinum points that were dipped into cups of mercury by each vibration of the pendulum. A stream of water was passed over each mercury meniscus in order to wash away the electrolytic products that would otherwise accumulate there.

¹ STOREY: This journal. 1903. viii, p. 355.

In those experiments where tetanizing currents of short duration were employed, the duration of flow of the current through the primary coil was regulated by the pendulum which closed that current during a certain part of each vibration. The interruptor on the primary coil was kept vibrating by an independent current.

The inductorium used was an upright form with 10,340 turns on the secondary coil.

The left abductor indicis muscle was used throughout.

The make shock was never sufficiently abrupt to cause a visible contraction, so that all the contractions in these experiments may be regarded as having been excited by the break shock. In no case was the shock strong enough to cause pain.

EXPERIMENTS.

Experiment I. — This experiment was performed upon Mr. L. on February 17, 1902, at 5 P. M. The resistance to be overcome in contraction was that of a light rubber band. Four Edison-Lalande cells furnished the primary current. Each stimulation was caused by a single induced shock, and the

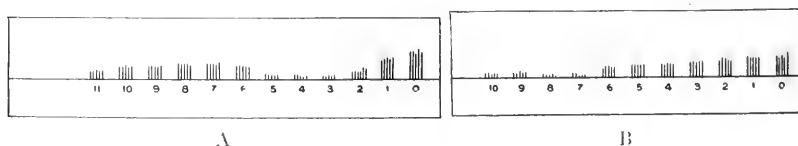

FIGURE 1.

muscle was excited once each second for five seconds, after which there followed a rest for five seconds. The position of the secondary coil was shifted one centimetre nearer the primary coil during each rest period. The part of the curve labelled "A" was made with the kathode over the muscle, and the part "B" was made with the anode over the muscle.¹

It will be noted on looking over Fig. 1 that, with the kathode over the muscle, the induced shock was able to excite a visible contraction when the secondary coil was placed at a distance of 11 cm. from the primary coil. The height of the contractions is greater at 10 cm., and continues to increase till the secondary is placed at 8 and 7 cm. when a maximal height seems to have been reached. From this position to that at 4 and 3 cm. there is a decrease in height at each position of the secondary. Then as the secondary is drawn on over the primary coil each centimetre of change produces an increase

¹ All figures in this paper are to be read from left to right.

in the height of the contractions excited by the induced shocks. This is the second period of maximum contractions.

With the anode over the muscle the induced shock is not able to excite a contraction until the secondary coil is placed at 10 cm. distance. The successive changes in the position of the secondary coil produce the same relative changes in the height of the contractions that were noted with the kathode over the muscle. The second period of increasing heights of contractions arrives sooner in this case than with the kathode over the muscle.

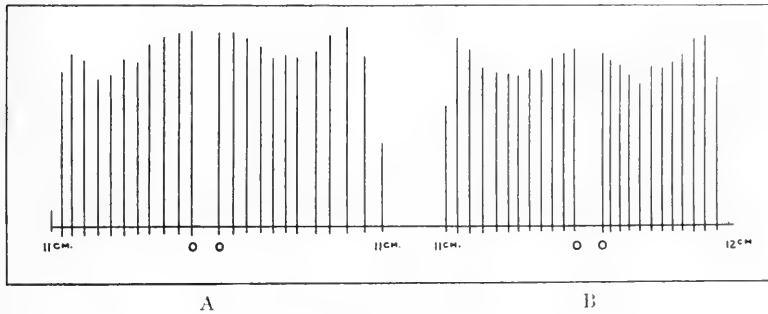

FIGURE 2.

Experiment II. — The writer was the subject in this experiment. It was done on the 25th of March, 1902, at 3 P. M. The resistance to be overcome was a weight of 100 grams. Three cells were placed on the primary circuit. Each stimulation was from a tetanizing current of one-tenth of a second in duration, and was formed of six interruptions. Each vertical record was made by six superimposed myograms made at intervals of one second. A rest of ten seconds followed each series of six contractions. The secondary coil was shifted one centimetre during each period of rest. Part "A" of the figure below was done with the kathode over the muscle, and "B" with the anode over the muscle.

It is apparent that the same relations are present in Fig. 2 that were noted in Fig. 1. As the secondary coil is drawn down over the primary coil and the strength of the induced shock is thereby increased there is first an increase in the height of contraction as each centimetre of change is made; then, after reaching a maximal height, the contractions decrease in height as each centimetre of change is made; after which comes another, the final, period of increasing heights of the contractions, producing a second maximum. As the secondary coil is shifted away from the primary, the same relations appear again.

Experiment III.— This experiment was performed upon Mr. A. B. S. on March 25th, at 5 P. M. The only difference between the conditions in this experiment and those of the preceding experiment is that four Edison-Lalande cells were used on the primary current instead of three.

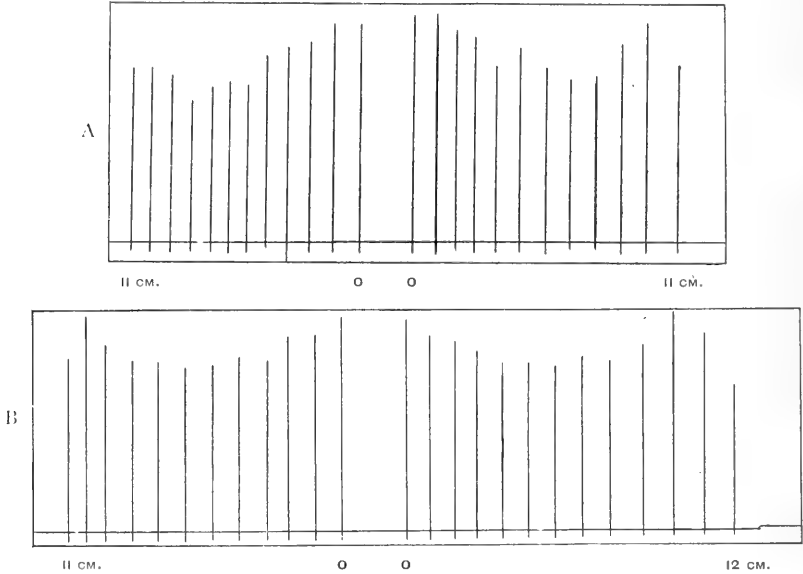

FIGURE 3.

Fig. 3 shows the same relations that have been pointed out in Figs. 1 and 2, and the same description may be made for it that has been made for them.

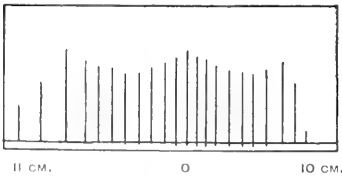

FIGURE 4.

Experiment IV was made upon the writer, and was done on the 1st of March, 1902, at 4 P. M. There were three Edison-Lalande cells in the primary circuit. Each stimulation was formed of sixty interruptions of the primary current, and occupied a period of one second's duration. The kathode was over the muscle

during the whole experiment. A rest of ten seconds followed each tetanic excitation. During this period of rest the secondary coil was shifted, as in the preceding experiments. The resistance to be overcome by the muscle was formed by a strong spiral spring.

The relations of the various parts of this figure to each other and to the variations in the strength of the exciting current are the same as were noted in the preceding figures.

CONCLUSIONS.

The writer has performed a number of experiments like the above and has found the same characteristic relationships in all of them. This relationship may be stated generally as follows: At some position of the secondary coil, the excitation by the induced shock will cause only a faint quiver of the muscle. Increases in the strength of the exciting shock causes corresponding increases in the heights of the muscular contractions. Soon, however, additional increases in the strength of the induced shock fail to cause proportional increases in the height of the contractions. Then further increases in the strength of the induced shock produce contractions of decreasing heights. Finally still greater increases in the strength of the induced shock cause a second period of contractions of increasing heights. There is, then, with graded increases in the strength of the induced shock: first, a period of increasing height of contractions; second, a period of maximal contractions; third, a period of decreasing height of contractions; fourth, a period of increasing height of contractions; and finally, a second period of maximal contractions.

In these experiments the same results were obtained with either the anode or the kathode applied directly to the muscle. However, the physiological electrotonic conditions present must have been complex, so that one is not justified in inferring from this last stated fact that electrotonic influences have nothing to do with the effects of graded changes in the strength of the exciting current.

LITERATURE.

So far as the writer is aware this phenomenon has not been observed before with human voluntary muscle. It has been noted by several investigators who have worked with the muscle-nerve preparation from the frog.¹ These writers have described their observations under the titles of "Die Lücke," "Die Intervalle," and "The Gap," these terms referring to the interval of lower contrac-

¹ The literature bearing upon the Gap (Die Lücke) has been considered exhaustively by BIEDERMANN, *Electrophysiologie*, Jena, 1895, ii, pp. 624, 648, and by HERMANN, *Handbuch der Physiologie*, 1879, ii, p. 107. In later years the subject has been briefly considered by LOCKE, *Journal of physiology*, 1900, xxvi, p. xxix, and by ROSENTHAL, *Allgemeine Physiologie der Muskeln und Nerven*, Leipzig, 1899, p. 303.

tions occurring between the periods of the first and second maximal contractions. The phenomenon has appeared in response to changes in the strength or to changes in the duration of the galvanic current and to changes in the strength of the induced current such as have been described in this paper. In these investigations the electrodes have been placed upon the nerve trunk and the effects of ascending and descending currents have been compared. One set of investigators has found that the phenomenon occurs with ascending currents and not with descending currents. This has given rise to the supposition that with the ascending current and a slight or short stimulation, the anodic block is not present and consequently the impulse started by the cathodic excitation reaches the muscle. With graded increases in the strength or the duration of the current there is for a time a corresponding increase in the heights of the contractions evoked. Soon, however, the anodic block begins to interfere with the passage of the impulse started at the kathode. This block may at a certain stage be sufficient to bar out the influence of the cathodic excitation. The muscle then ceases to contract. Later, with stronger or with longer stimulations, the anodic rebound or disappearance of anelectrotonus acts as a stimulus and the muscle is again excited to contraction. The first period of maximal contractions is due to cathodic excitation ; the interval of lower contractions is due to the interference of the anodic block ; and the second period of maximal contractions is due to excitation from the anodic rebound.

Other investigators, however, have found that this phenomenon does appear with descending currents. This would indicate the presence of some influence other than anelectrotonus.

THE LAKING OF DRIED RED BLOOD-CORPUSCLES.

By CHARLES CLAUDE GUTHRIE.

[From the *Physiological Laboratory, Western Reserve University.*]

HAVING accidentally observed that chicken's and human red blood-corpuscles, allowed to dry in the air at room temperature, are readily laked by 0.9 per cent NaCl solution, I mentioned the fact to Dr. G. N. Stewart, who told me that he had published an observation to the same effect in regard to *Necturus* corpuscles.¹

He recommended me to make a more systematic investigation of the phenomenon; among other reasons, on account of its practical importance, in connection with the usual procedure for the examination of blood-stains in medico-legal cases.

I take this opportunity to express my thanks to him for his invaluable assistance.

The action of a large number of reagents on the dried red corpuscles, of man, the dog, cow, rabbit, chicken, and frog was studied.

Briefly the procedure was this: Thin layers of blood were spread on glass slides, by drawing a film across the surface of one with the edge of another. These were then allowed to dry, either at room temperature or in an oven heated to various temperatures, after which a cover slip was applied and the slide examined with the microscope. A drop of the reagent was then placed on the slide at the margin of the cover slip and allowed to spread into the preparation. The reaction was observed from beginning to end, through the microscope.

Dried stains on cloth were also examined by scraping the cloth above a slide, thus causing the corpuscles to fall upon it, laying on a cover slip, and then applying the reagent in the manner above described. In some experiments the films of blood were dried in test tubes.

The following is a summary of the results obtained:—

Rapid laking is produced

1. By addition of the animal's own, or the serum of another animal

¹ STEWART: This journal, 1902, viii, p. 117.

2. By addition of aqueous solutions of non-electrolytes and electrolytes (salts, acids, and bases)¹ except such as readily convert the hæmoglobin into insoluble substances; *e. g.*, strong solutions of sodium hydroxide.

3. In general, rapidity of laking is in direct ratio to the strength of the solution, to a point approaching saturation, above which the ratio is reversed.

4. Solutions of glycerine lake in proportion to the percentage of water they contain.

5. Ethyl alcohol containing much more than 5 per cent of water produces an amount of laking, before the corpuscles are fixed, proportionate to the percentage of water present. If it contains 50 per cent of water, practically complete laking occurs; if less than 5 per cent, the corpuscles are fixed without laking.

6. Chloroform, ether, benzole, and xylol produce no laking, and if removed after a period of contact of from one to five minutes, the corpuscles lake as before, on addition of the solutions mentioned above.

7. The laking action is not dependent on, or indeed, influenced, to any appreciable extent, by the dried serum constituents of the blood, since there is no difference when corpuscles, washed free from serum constituents by 0.9 per cent NaCl solution before drying, are employed.

8. The laking action is not essentially affected by varying the temperature at which it is carried out, within the limits of 25° to -2° C.

9. Thin films of blood or of washed corpuscles dried at room temperature and then heated in an oven for twenty minutes at temperatures up to 100° C. are laked by the reagents just as if they had not been heated.

It is known that oxyhæmoglobin dried completely below 0° C. can be heated to 100° C. without decomposition.²

Dr. Stewart heated to 100° C. for two hours a specimen of dog's

¹ The non-electrolytes used were distilled water, ether, chloroform, chloral hydrate, benzole, ethyl alcohol, glycerine, phenol, formaldehyde, aniline, boracic acid, cane sugar, and glucose.

The electrolytes were sodium chloride, sodium carbonate, sodium hydroxide, sodium sulphate, potassium dichromate, potassium ferrocyanide, ammonium chloride, ammonium hydroxide, ammonium sulphate, mercuric chloride, hydrochloric acid, sulphuric acid, nitric acid, methylene blue, and eosin.

² HOPPE-SEYLER'S Handbuch, 6th ed., p. 277.

oxyhæmoglobin which had been kept dry in a closed desiccator, and which had been largely changed into methæmoglobin, as shown by the spectroscope. It was still soluble to some extent in distilled water, although much less so than before heating, and the spectrum of the filtered solution was the same as before heating. It is obvious that the constituents of the colored corpuscles are not easily fixed by dry heat. As is well known, Ehrlich recommends that films be heated at 120° C. for two hours. Corpuscles are, of course, fixed at a much lower temperature if water be present; *e.g.*, if they be poured, into boiling 0.9 per cent NaCl solution. There is then no effect produced by any of the reagents which lake the dried corpuscles.

10. The precise amount of water which must be removed from the corpuscles in order to produce the alteration in the envelope, or stroma, on which the action depends, has not been exactly determined. But that some of the intracorpuseular water, in addition to extra corpuscular water, must be removed, is indicated by the following experiments.¹

Dog's defibrinated blood was washed free from serum constituents with 0.9 per cent NaCl solution, and the sediment of corpuscles separated as thoroughly as possible from the salt solution, by long-continued centrifugalization in the cold. The sediment was then partially dried in a flat dish over sulphuric acid in vacuo, in a cold room. The dried crust was broken through and some of the still moist sediment removed. A portion of it was at once weighed in a platinum dish, then dried at 110° C. till it ceased to lose weight. The percentage of water in the partially dried sediment was thus arrived at. Another portion was suspended in 0.9 per cent NaCl solution, to see whether the corpuscles would remain unlaked, as normal corpuscles do in this solution. It was found that in two experiments many of the corpuscles remained unlaked for several hours in the salt solution, although the proportion of water in the sediment in one of the experiments was only 50 per cent and in the other 56 per cent. The percentage of water in the colored corpuscles is usually given as about 60 per cent. There must certainly have been some extra corpuscular water in the sediment, so that on the average the corpuscles must have lost some water. This would necessarily happen as the concentration of the salt solution increased during the drying. But some of the corpuscles were laked and crystals of hæmoglobin deposited in the partially dried sediment, and some of the water belonging to these corpuscles might have been distributed among those still intact. That the reduction of

¹ Performed by Dr. Stewart.

water in the sediment to 50 per cent was not without injurious effect, even on the unlaked corpuscles, was shown by the fact that they laked completely in salt solution, on standing over-night in the cold.

When gradual drying is allowed to take place, as in a small drop of blood or of washed suspension of corpuscles, on a slide covered with a slip, it may be seen, as Dr. S. Peskind pointed out to me, that the corpuscles at the edge of the drop become markedly swelled. Dr. Stewart has demonstrated to me that there is also extensive laking here, even in the case of corpuscles which at the moment of laking are floating in the liquid. It may be that drying of a portion of the circumference of a corpuscle (the outer edge in the case of corpuscles at the edge of the drop), or the action on it of the concentrated salt solution produced by evaporation, may render the rest of the circumference more freely permeable to the salts of the solution or to water, and thus give rise to water laking. My own observations on the drying of uncovered films led me to suppose that nearly all the water must be gotten rid of, if all the corpuscles are to lake in the solutions investigated.

11. The nuclei of dried nucleated red corpuscles are dissolved by solutions which lake the corpuscles. The action is more energetic in the solutions of electrolytes investigated than in the non-electrolytes, and bears the same relation to strength of solution as the laking action does.

12. Dried corpuscles kept at room temperature for as much as twenty-eight days show no appreciable difference from freshly dried corpuscles, as regards these reactions.

13. The white corpuscles were observed to behave much like the nuclei of nucleated red corpuscles, except that they are more slowly acted upon than the nuclei.

14. On drying blood and suspending the resulting powder in ether, and then cautiously adding water, agglutination of the corpuscles occurred, this being shown by the formation of a sticky precipitate which adhered to the bottom of the test tube. It was also observed through the microscope by means of a hollow-ground slide. Laking takes place after agglutination. It also occurs when corpuscles thoroughly washed with salt solution are dried and treated in the way described. It follows that this agglutination of dried corpuscles is not dependent on any organic serum constituent. It occurs in direct ratio to the percentage of water present. It is known that

the addition of water to normal corpuscles causes agglutination before laking. Apparently, then, although the envelope has been profoundly altered by drying in regard to its permeability to the solutions investigated, it still retains those constituents, or those properties, on alteration of which agglutination depends.

I shall not, at present, discuss the nature of the change which drying produces in corpuscles, and on which the reactions described, depend. Dr. Stewart has shown that fixing washed corpuscles by pouring them into boiling salt solution greatly increases their permeability to ions.¹ It is very probable that this is true also for neutral molecules, and, no doubt drying at a temperature below that necessary for fixation, profoundly alters the permeability of the corpuscles for diffusible substances, while it allows of the escape of hæmoglobin when enough water to dissolve it is present.

There is one practical application of the results on which a few words may be permissible.

In the accessible literature on the microscopic examination of blood-stains for corpuscles, it is usually recommended to add various solutions to the stains. For instance, Reese² gives a list of six reagents to be used in the examination of blood-stains, viz.:

1. Water.
2. Potassium hydroxid 1 part.
Water 2 parts.
3. Müller's fluid: —
Potassium dichromate 1 part.
Sodium sulphate 2 parts.
Water 100 parts.
4. Müller's fluid.
Glycerol, q. s.
The glycerol is added until a specific gravity of 1028 is obtained.
5. Glycerol 1 part.
Water 6 parts.
6. Sodium sulphate 6 parts.
Water 8 parts.

Now all of these, except the second (Virchow's fluid, 30 per cent KOH), produce rapid laking, though the solutions containing potassium dichromate (Nos. 3 and 4), leave the ghosts stained fairly well.

¹ Journal of medical research, 1902, viii, p. 273.

² REESE: Text-book of medical jurisprudence and toxicology, 5th ed., 1898, p. 139.

Simon¹ recommends the treatment of blood-stains with water for the microscopical detection of corpuscles. Sometimes it is vaguely suggested that, under certain conditions, the corpuscles are liable to undergo changes, although it seems rarely to be suspected that the liquids with which they are in contact are responsible for the changes. For instance, "If the stain upon the garment has been moist, or submerged in water for a considerable time, decomposition may have led to the dissolution of the corpuscles," and again, "Solutions of the same specific gravity of the blood, or lighter, will lead to the eventual swelling up and dissolution of the corpuscles."²

In the light of the results given above, such statements need revision.

Directions to wash blood-stains in water, or solutions of the same specific gravity as blood, if followed, will in general give a suspension of "ghosts" or "shadows" of red corpuscles which may easily be overlooked, unless staining methods are subsequently resorted to, and then it is difficult to bring them out distinctly.

In any event it appears more reasonable to treat the stain with one of the non-laking solutions.

By scraping dried blood-stains on cloth above a slide, thus causing the corpuscles to fall upon it, and then laying on a cover slip and applying a solution of eosin in 96 per cent alcohol, good results were obtained.

Before the discovery of the biological blood test, numerous writers laid stress on the importance of measuring the average diameter of the corpuscles in blood-stains. As a matter of fact, the corpuscles in an ordinary dried stain on cloth are distorted to a greater or lesser degree, depending largely on the rapidity with which they are dried, and it is difficult to find any which show no evidence of crenation. Measurements, therefore, would seem to be of small value, as it is difficult to suppose that the corpuscles will swell up and assume their normal dimensions if placed in solutions of the same specific gravity as the blood, or that the same amount of contraction occurs, in all cases, in drying.

¹ SIMON : Manual of chemistry, 1901, p. 511.

² REESE : *Loc. cit.*, pp. 138, 142.

ON THE NUCLEOPROTEIDS OF THE PANCREAS,
THYMUS, AND SUPRARENAL GLAND, WITH
ESPECIAL REFERENCE TO THEIR
OPTICAL ACTIVITY.

BY ARTHUR GAMGEE AND WALTER JONES.¹

ALL observations hitherto published concerning the optical activity of the albuminous bodies have led physiological chemists to believe that the bodies thus designated, whether derived from the vegetable or animal kingdom, without a single exception, deviate the plane of polarization to the left, no case having been hitherto made known either of a dextrogyrous, a racemic, or an otherwise inactive albuminous substance.

There is one group of albuminous substances which (whether we consider them from the standpoint of their paramount physiological importance, or from that of their startlingly interesting physical properties, or lastly from that of their chemical relationships) possesses quite exceptional interest, and which has, unaccountably, been allowed to remain uninvestigated (in so far as optical activity is concerned) until one of us, very recently, initiated an inquiry which, at its very threshold, revealed an unexpected and, in a sense, startling result. The group to which we refer is that which has been designated by German writers the "Proteïde." This group comprises those highly complex albuminous substances which can, with greater or less ease, be split up into, or which yield as products of decomposition, on the one hand, albuminous bodies, and on the other, such bodies as coloring matters, or nucleinic acids and the nuclein bases, or, in certain cases, carbohydrates. The best characterized and most striking members of this group are: first, hæmoglobin and its compounds; secondly, the nucleoproteids.

In hæmoglobin we have the example of a complex proteid which differs from all other albuminous bodies by its color, by its marvellous power of forming easily dissociable compounds with oxygen and with

¹ Read before the American Physiological Society, December 30, 1902, at Washington, D. C.

certain other gases, by the facility with which it admits of being crystallized and recrystallized and obtained free from all foreign mineral impurities, and by the startling manner in which its solutions fail to furnish any one of the reactions characteristic of albuminous substances in solution, *so long as the reagent has not effected a fundamental decomposition which has liberated the albuminous and colored residues*. The researches of one of us¹ had, moreover, lately demonstrated that although hæmoglobin is definitely a diamagnetic body, the iron-containing products of its decomposition by acids are not merely paramagnetic, but actually the most powerfully "ferromagnetic" organic bodies known to science. So complete a divergence was thus shown to exist in every physical and chemical property between hæmoglobin and the substances which are linked together in it, that it appeared to be in the highest degree interesting to ascertain whether, or not, in respect of optical activity, hæmoglobin would behave as an albuminous substance proper and prove to be "lævogyrous."

In a research in which one of us (A. G.) was associated with Dr. A. Croft Hill, and of which the results have not yet been published, it has been discovered that hæmoglobin is a dextrogyrous body possessing a specific rotation for monochromatic red light having the mean wave length of Fraunhofer's line C of 10.8° . On the other hand, the interesting histon-like albuminous substance globin, of which the leading characters have only been known since the researches of Schulz, is a normally lævogyrous albuminous body with a specific rotation -69° .

These interesting observations naturally suggested the probability that the nucleoproteids might, like hæmoglobin, prove to be dextrogyrous, and the research of which the first results are related in this paper is the outcome of this idea. The hypothesis which led to its being undertaken, has been confirmed, as will be shown in the sequel, and it has thus been proved that, contrary to the traditional belief, some at least of the members of a group of albuminous bodies of signal importance in the life-history of the organism are dextrogyrous bodies.

¹ GAMGEE: On the behavior of oxy-hæmoglobin, carbonic-oxide-hæmoglobin, methæmo-globin, and certain of their derivatives, in the magnetic field, with a preliminary note on the electrolysis of the hæmoglobin compounds. Proceedings of the Royal Society, 1901, lxxviii, p. 503: The Croonian Lecture: On certain chemical and physical properties of hæmoglobin. Proceedings of the Royal Society, 1902, lxx, p. 79.

THE NUCLEOPROTEID OF THE PANCREAS.¹

The preparation of nucleoproteids that can be made into solutions sufficiently colorless and transparent for polarimetric work is a matter that is attended with considerable difficulty. In an endeavor to improve in this respect upon the methods already known (and this was found absolutely necessary in the very beginning of the work), we found a very interesting optical relation between the nucleoproteids proper and their first hydrolytic products, the nucleins. We therefore give the method in some detail.

The finely divided pancreas of the pig was treated in turn with 50 per cent alcohol, 75 per cent alcohol, and 95 per cent alcohol, and finally dried with absolute alcohol and ether. The material thus obtained was extracted with several successive portions of a 5 per cent solution of ammonium acetate, the united extracts were filtered, and the perfectly clear fluid was poured into four times its volume of weak alcohol. The precipitate thus formed was washed by decantation with an excessive amount of dilute alcohol, and finally dried with absolute alcohol and ether. The object of this procedure was to remove the coloring matter of the gland which is somewhat soluble in dilute alcohol, more so in an alcoholic solution of ammonium acetate, but soluble to a very slight extent in an aqueous solution of ammonium acetate. The manipulation also removes a large amount of inorganic salts, and renders the coagulable proteids insoluble. A 2 per cent filtered aqueous solution of this material had only a pale yellow color, and could easily be polarized in a 220-mm. tube. The result of this optical examination showed that there was present a dextrorotatory substance. The solution, moreover, failed to give any indication of a reducing substance, even by prolonged boiling with Fehling's solution, and was shown to be rich in material which produces xanthine bases on hydrolysis with sulphuric acid.

The main portion of this material was dissolved in twenty parts of water, and the filtered solution treated with dilute acetic acid a drop at a time. When a quantity of acid had been added sufficient to bring the entire solution to about 1 per cent, a well-defined white flocculent

¹ We have used the term "nucleoproteid" in certain instances to include all compound proteids which yield nucleic acids on hydrolysis, even though the substances so designated be nucleins or nucleohistones. In other cases we have used the term in contradistinction to nuclein, but we have taken some care that the context shall show the exact meaning in each instance.

precipitate was produced. This precipitate, which for the present we will call nucleoproteid, was separated by the centrifuge, suspended in water, and treated with an extremely dilute solution of ammonia, drop by drop, as the reaction of the fluid was carefully noted with litmus. A very small amount of alkali was required to neutralize the adherent acetic acid when the solution became neutral, and remained so until approximately twice as much ammonia had been used as was required to completely dissolve the nucleoproteid. Evidently the nucleoproteid is at least a dibasic acid whose acid ammonium salt is soluble in water and neutral to litmus. Purification was effected by alternate solution in ammonia and precipitation with a minimal amount of acetic acid. The final solution was poured into five volumes of 95 per cent alcohol, washed repeatedly by decantation with excessive quantities of 95 per cent alcohol, finally dried with absolute alcohol and ether, and placed in a desiccator with sulphuric acid.

The fluid from which the nucleoproteid was originally precipitated was treated with 20 per cent acetic acid, a drop at a time. When the fluid contained 2 per cent of the acid, not the slightest precipitation had occurred. Continued addition of acetic acid, however, soon causes a turbidity, and when the acidity reaches 5-6 per cent, a well defined flocculent precipitate occurs. This precipitate, which we will for the present call nuclein, was separated in the centrifuge, and, at a great sacrifice of material, was washed twice in the centrifuge with small portions of water. The nuclein was suspended in water, and ammonia added in small portions, a drop at a time; when the nuclein was completely dissolved, the fluid was still acid to litmus. This solution was poured into four volumes of 95 per cent alcohol, and the precipitated nuclein washed and dried by the method described for the nucleoproteid.

The fluid from which the nuclein was precipitated by a great excess of acetic acid, was poured into four volumes of alcohol, and the precipitate washed and dried with alcohol and ether. This preparation, which is necessarily very impure and especially rich in inorganic salts, will be designated as "residual material."

Thus, by functional precipitation with acetic acid in the presence of inorganic salts, we have gotten possession of three preparations. The nucleoproteid is almost insoluble in water, but may be dissolved by the addition of ammonia or caustic soda. The nuclein is soluble in water with the greatest ease. By the addition of a trace of copper

sulphate to a solution of the nucleoprotein in caustic soda, a fine pink color is produced, but not a shade of violet makes its appearance until a comparatively large amount of copper solution has been used, a reaction which resembles closely the biuret test with proteoses. The nuclein by similar treatment gives only the faintest pink color, the violet shade being observed even when a very small amount of copper sulphate is used, while the "residual material" produces a violet color from the beginning.

It has lately been shown by one of us that the nucleoprotein yields two xanthine bases, guanine and adenine, and in a ratio which closely approximates four equivalents of the former to one of the latter.¹ The nuclein and residual material were also shown to yield xanthine bases on hydrolysis with sulphuric acid, and it may be conveniently stated here that all substances which we have described were found to yield, on complete hydrolysis, products which respond to the xanthine color reaction, and which form compounds with silver nitrate which are insoluble in ammonia. All three of the preparations under discussion contain phosphorus, all are completely precipitated from aqueous or faintly alkaline solutions by the addition of a trace of hydrochloric acid, and all yield precipitates on boiling in neutral solution.

We believe sufficient evidence has been cited to justify the terms nucleoprotein and nuclein, and we may add that, in our opinion, there is contained, in the preparation called "residual material," a nuclein still more closely related to a nucleic acid. In all of our experiments we have noticed that any property which is more marked in the nuclein than in the nucleoprotein finds still greater expression in the residual material. This was found well illustrated by a study of their action on polarized light. All three preparations are dextrorotatory. The specific rotation of the nucleoprotein is $+38^\circ$, that of the nuclein $+65^\circ$, while it can be indirectly shown that a substance is contained in the residual material whose specific rotation is about $+81^\circ$.

OPTICAL PROPERTIES.

A weighed amount of the nucleoprotein was suspended in water, and dissolved by the addition of a trace of ammonia. The solution was then made up to a definite volume with water, and polarized.

¹ JONES and WHIPPLE: This journal, 1902, vii, p. 423.

Weight of material (w)	1.0064 gm.,
Volume of solution (v)	25 c.c.,
Observed angle (α)	+3° 4',
Length of tube (l)	2 dm.

$$(\alpha)_D = \frac{\alpha v'}{l w} = +38.1^\circ$$

A similar experiment with another preparation of the nucleoproteid gave the following data :

Weight of material	0.5003 gm.,
Volume of solution	25 c.c.,
Observed angle	+1° 30',
Length of tube	2 dm.

$$(\alpha)_D = \frac{\alpha v'}{l w} = +37.5^\circ$$

The solution was treated with an excess of acetic acid and the precipitate filtered off. The filtrate was found inactive.

A solution of a preparation of the nucleoproteid which was known to be somewhat contaminated with nuclein was polarized in a 200-mm. tube and gave a reading of 1° 34'. Acetic acid was added and the precipitate filtered off. The filtrate, polarized in a 200-mm. tube, gave a reading of 22'. The solution was then treated with hydrochloric acid, when the filtrate from the precipitated nuclein was found inactive.

We gained good evidence that the specific rotation of the nucleoproteid would be found less than that of the nuclein before we had made quantitative experiments with the latter substance. A perfectly neutral solution of nucleoproteid was prepared by treating some of the material with water and an insufficient amount of ammonia to effect complete solution. The filtered fluid, polarized in a 200-mm. tube gave a reading of +1° 46'. The solution was heated to boiling and the coagulum filtered off. The filtrate, polarized in a 200-mm. tube, gave a reading of 1° 49'. It is well known that boiling converts nucleoproteids into nucleins. As the length of tube and angle of rotation remained constant, a decrease in the amount of material must mean an increase in the specific rotation.

The following observations were, therefore, not surprising. A solution of the nuclein was made in water, and as the fluid was somewhat colored, it was necessary to use a dilute solution and a short tube.

Weight of material	1.0092 gm.,
Volume of solution	50 c.c.,
Observed angle	+1° 18',
Length of tube	1 dm.

$$(\alpha)_D = \frac{\alpha v'}{l w} = +64.4^\circ$$

The solution was treated with hydrochloric acid, and the filtered fluid polarized in a 200-mm. tube. The rotation was slightly negative ($-9'$).¹

As is the case with the nucleoprotein, a solution of the nuclein yields a coagulum on heating, and the rotation of the solution is not appreciably changed. This would lead us to assume the existence of a nuclein whose specific rotation is greater than $+64.4^\circ$. It can easily be proved that such a substance exists in the preparation which we have designated as "residual material." A weighed amount of this material was dissolved in a measured volume of water. The solution was polarized, treated with hydrochloric acid, and the amount of solid matter determined in the optically inactive filtrate. The following data were obtained:

Weight of material used	0.5207 gm.,
Weight of optically inactive material	0.2691 gm.,
Weight of optically active material	0.2516 gm.,
Volume of the solution	25 c.c.,
Observed angle	$1^\circ 38'$,
Length of tube	200 mm.

$$(\alpha)_D = \frac{\alpha \tau'}{l'w} = +81.1^\circ.$$

ON HAMMARSTEN'S PREPARATION.

The results which have already been detailed made an optical examination of this substance highly desirable. By slight departures² from the method described by Hammarsten, which were absolutely necessary to remove coloring matter, and which cannot possibly have exercised any great influence on the chemical nature of the product, we were able to prepare a nuclein which must be identical with Hammarsten's preparation. From its method of preparation, we would imagine that the substance is a nuclein. The material which we obtained gave a violet biuret reaction, and is soluble in water. Its solution was highly colored, but possessed so great a rotatory power

¹ We noticed several times that very slightly levorotatory filtrates were obtained when hydrochloric acid was used for precipitating the proteid, and especially so when the acid fluid was allowed to stand in contact with the precipitate. It is probable that the negative rotation is due to slight hydrolysis, in which an optically negative proteid is formed which is soluble in hydrochloric acid.

² We used ammonia for redissolving the nuclein, where HAMMARSTEN used an alkali. We also finally poured an aqueous solution of the proteid into 95 per cent alcohol, and washed by decantation instead of washing on a filter.

that fairly satisfactory polarimetric observations could be made in solutions of extreme dilution. The proteid is dextrorotatory.

Weight of material	0.2001 gm.,
Volume of the solution	25 c.c.,
Observed angle (the mean of eight readings)	+47',
Length of tube	100 mm.

$$(\alpha)_D = \frac{\alpha_D}{l \cdot c} = 97.9^\circ.$$

ON THE NUCLEOHISTONE OF THE THYMUS.

It would seem quite easy to obtain this substance in any desired quantity by the very simple method which Lillienfeld describes in twenty lines. This method leads to a product whose solutions are highly opalescent, and an optical examination is not to be thought of. The cloudiness is so persistent that for a long time we were inclined to believe it a property inherent in the proteid. We finally succeeded, however, in obtaining solutions almost as colorless and transparent as distilled water.

It is only necessary to extract Lillienfeld's preparation with a 5 per cent solution of ammonium acetate and filter. The fluid filters very slowly, but perfectly clear and continuously. The solution was poured into 95 per cent alcohol, and the precipitated proteid washed and dried with alcohol and ether, as described in connection with other preparations. The substance thus obtained was submitted to an optical examination with the following results. The solution was made in very dilute ammonia.

Weight of material	2.023 gm.,
Volume of the solution	50 c.c.,
Observed angle	3° 20',
Length of tube	220 mm.

$$(\alpha)_D = \frac{\alpha_D}{l \cdot c} = +37.5^\circ.$$

ON THE NUCLEOPROTEID OF THE SUPRARENAL GLAND.

As is well known, the characteristic physiologically active constituent of this gland forms a dark brown pigment when exposed in aqueous solution to the oxidizing action of the air. Aqueous extracts of the gland are, therefore, always highly colored, and this coloring matter offers great difficulty in the preparation of substances from the glands which are intended for optical examination. While the

work on the nucleoprotein is, therefore, not as satisfactory as we desire, it can nevertheless be stated positively that the nucleoprotein is dextrorotatory.

One of us has lately described this substance, and shown that it yields of the xanthine bases only guanine and adenine. These two bases (together with thymine) are to be found among the hydrolytic products of the nucleoprotein in a molecular ratio which closely approximates 4 : 1.¹

The method of isolation does not essentially differ from that formerly employed, except that the gland was extracted several times with acetic acid before removing the nucleoprotein. A substance was finally obtained which was too much colored for accurate polarimetry, but which, even in the necessarily high dilution employed, could easily be shown to be dextrorotatory.

Weight of material	0.1992 gm.,
Length of tube	100 mm.,
Volume of solution	25 c.c.,
Observed angle	23'.

$$(\alpha)_D = \frac{\alpha \tau'}{l \pi w} = +48.1^\circ.$$

The value of this rotation is liable to revision, but its direction is beyond question.

CONCLUSION.

We have described six preparations, obtained from various glands, and have given methods by which several of these may be isolated sufficiently free from coloring matters for exact polarimetric work. All six of these substances yield, on hydrolysis, phosphoric acid and purine derivatives, and are therefore to be considered as nucleoproteids in the wide sense of the term.

The methods of preparation were such as to exclude all dextrorotatory substances that are not of a proteid nature, and all preparations were shown to be free from substances which reduce Fehling's solution, even on prolonged boiling. Nevertheless all of these preparations were found to be dextrorotatory, having specific rotations which vary from +37.5°, that of the nucleohistone of the thymus, to +97.9°, that of Hammarsten's nuclein of the pancreas.

¹ JONES and WHIPPLE: *Loc. cit.*

ERRATA.

Page 337, line 23, for gm. read mg.

Page 346, line 27, for 25 per cent, read 2.5 per cent.

INDEX TO VOL. VIII.

- A**BEL, J. J. On the behavior of extracts of the suprarenal gland toward Fehling's solution, xxx.
- A**BEL, J. J. On the elementary composition of adrenalin, xxix.
- A**BEL, J. J. On the oxidation of epinephrin and adrenalin with nitric acid, xxxi.
- Absorption after nephrectomy, xlii.
- Adrenalin, action upon blood-vessels, xlii.
- , composition, xxix.
- , oxidation, xxxi.
- Alcohol, action on muscle, 61.
- ALDRICH**, T. B. See **HOUGHTON** and **ALDRICH**, xviii.
- AMBERG**, S. The toxicity of epinephrin (adrenalin), xxxiii.
- Ammonia, determination in urine, 330.
- Artificial respiration in strychnine poisoning, xlii.
- ATWATER**, W. O. On the sources of muscular energy, xlii.
- B**ACILLUS coli communis, chemical products, 284.
- Bacillus lactis aerogenes, chemical products, 284.
- Blood, electrical potential, xliii.
- , laking, 441, xliii.
- Blood-corpuscles and other cells affected by acids, 99, 404.
- Blood-corpuscles, hæmolytic, 103.
- Blood-pressure, in salmon, xlii.
- BOWEN**, W. P. Exhibition of mercury-mercury stimulator, xx.
- BOWEN**, W. P. Exhibition of new form of platinum-mercury stimulator, xx.
- Brain protagon, 183.
- C**AMPHOR, influence upon excretion of dextrose in diabetes, xxxii.
- CANNON**, W. B. Further observations on the movements of the stomach and intestines, xxi.
- CANNON**, W. B. Demonstration of the movements of the stomach and intestine, observed by means of the Röntgen rays, xli.
- CANNON**, W. B., and **H. F. DAY**. Salivary digestion in the stomach, xxviii.
- CARLSON**, A. J. See **JENKINS** and **CARLSON**, 251.
- Cannula, tracheal, xxiii.
- Cardio-pneumatoscope, xxii.
- Coagulation of milk, xxxv.
- CUSHING**, H. The effect of extirpation of the Gasserian ganglion upon the sense of taste, xxvii.
- D**AY, H. F. See **CANNON** and **DAY**, xxviii.
- Diabetes, xxxii.
- Development of eggs affected by mechanical shock, 301.
- Diaphragm, apparatus for illustrating its action, xlii.
- Digestion, salivary, in stomach, xxviii.
- DODGE**, R. Five types of eye movement in the horizontal meridian plane of the field of regard, 307.
- E**LECTRICAL convection of cells and nuclei, 273.
- Electrical polarity in hydroids, 294.
- Electro-magnetic signal, xxii.
- Energy, muscular, source, xlii.
- Epinephrin, xxxiii.
- , oxidation, xxxi.
- Eye movements in horizontal meridian plane of field of regard, 307.
- F**ATIGUE, human muscle, 355.
- Fertilization, relation to development, 430.
- FISCHER**, M. H. How long does (arabacia) sperm live in sea-water? 430.
- FRANZ**, S. I. On the functions of the cerebrum: I. The frontal lobes in relation to the production and retention of simple sensory-motor habits, 1.
- Frog, long survival after removal of cerebral hemispheres, xlii.
- Frog-table, xxii.
- Frontal lobes, localization of habits, 1.

- GAMGEE, A., and W. JONES.** On the nucleoproteids of the pancreas, thymus, and suprarenal gland, with especial reference to their optical activity, 447, xlii.
- Gasserian ganglion, extirpation, xxvii.
- Gastric secretion, stimulated by alcohol, etc., xvii.
- Gelatine, digestion, xxiii.
- GIES, W. J.** The influence of the H ion in peptic proteolysis, xxxiv.
- GIES, W. J.** A proteid reaction involving the use of chromate, xv.
- GIES, W. J.** Further mucoid studies, xiii.
- GIES, W. J.** See **LESEM** and **GIES**, 183.
- GIES, W. J.** See **LOEB** and **GIES**, xiv.
- GIES, W. J.** See **MELTZER** and **GIES**, xlii.
- Glucophosphoric acid, xi.
- Glutathionic acid, xi.
- Glucuronic acid, origin, xiii.
- GORHAM, F. P., and R. W. TOWER.** Does potassium cyanide prolong the life of the unfertilized egg of the sea-urchin? 175.
- GREENE, C. W.** Arterial blood-pressure in the Sacramento salmon, *Oncorhynchus tshawtscha*, xlii.
- GREENE, C. W.** Osmotic changes in the Sacramento salmon during the run from the sea to the spawning beds, xlii.
- Growth on diet of skimmed milk, 197.
- GUTHRIE, C. C.** The laking of dried red blood-corpuses, 441, xliii.
- HABITS**, localization, 1.
Hæmolytic, 103.
- HATCHER, R. A., and T. SOLLMANN.** The effect of diminished excretion of sodium chloride on the constituents of the urine, 139.
- Heart lever, xxxviii.
- Heart, maximal contraction, "staircase" contraction, refractory period, compensatory pause, 213.
- Heart muscle, affected by sodium chloride, 75.
—, tonus, xxvi.
- HOUGHTON, E. M., and T. B. ALDRICH.** A preliminary report on the pharmacological and chemical properties of tribrom-tertiary butyl-alcohol, xviii.
- Human muscle, fatigue in voluntary contraction, 355.
- Hydroids, electrical polarity, 294.
- INDUCTORIUM**, xxv.
Intestine, movements, xxi, lxi.
Ions, toxic and antitoxic effects, xiv.
- JACKSON, H. C.** On the influence of camphor ingestion upon the excretion of dextrose in phlorhizin diabetes, xxxii.
- JACKSON, H. C.** See **MANDEL** and **JACKSON**, xiii.
- JACKSON, H. C.** See **WALLACE** and **JACKSON**, xvii.
- JENKINS, O. P., and A. J. CARLSON.** The rate of nervous impulse in certain molluscs, 251.
- JENNINGS, H. S.** Studies on reactions to stimuli in unicellular organisms. IX. On the behavior of fixed infusoria (*Stentor* and *Vorticella*), with special reference to the modifiability of protozoan reactions, 23.
- Joints, flexion and extension, xxiv.
- JONES, W.** On the xanthin bases of the suprarenal gland, xlii.
- JONES, W.** See **GAMGEE** and **JONES**, 447, xli.
- KEY, mercury**, xxii.
Kidney, glomerular fluid by filtration or secretion, 155.
- Kymograph, xxxvii.
- LABORATORY** apparatus, xxii, xxxv.
LEE, F. S., and W. SALANT. The action of alcohol on muscle, 61.
- LEE, F. S.** The action of ethyl-alcohol on contractile protoplasm, xix.
- LESEM, W. W., and W. J. GIES.** Notes on the "protagon" of the brain, 183.
- LEVENE, P. A.** On glucophosphoric acid, xi.
- LEVENE, P. A.** On glutathionic acid, xi.
- LEVENE, P. A.** On nucleic acid, xii.
- LEVENE, P. A., and L. B. STOOKEY.** On the biological relation of proteids and proteid assimilation, xxiii.
- LEVENE, P. A., and L. B. STOOKEY.** On the digestion of gelatine, xxiii.
- Life, duration affected by potassium cyanide, 175.
- LILLIE, R. S.** On differences in the direction of the electrical convection of certain free cells and nuclei, 273.
- LINGLE, D. J.** The importance of sodium chloride in heart activity, 75.
- LOEB, J., and W. J. GIES.** Further studies of the toxic and antitoxic effects of ions, xiv.
- LOEVENHART, A. S.** Some observations on the coagulation of milk, xxxv.
- LOMBARD, W. P.** The action of the two-joint muscles of the hind-leg of the frog, with special reference to the spring movement, xxiv.

- M**ACALLUM, A. B. On the origin of the relation of the inorganic elements to protoplasm, xlii.
- MANDEL, J. A., and H. C. JACKSON. On the origin of glycuronic acid, xlii.
- MATHEWS, A. P. Electrical polarity in the hydroids, 294.
- MATHEWS, A. P., and B. R. WHITCHER. The importance of mechanical shock in protoplasmic activity, 300.
- Mechanical shock, effect on protoplasm, 300.
- MELTZER, CLARA. See MELTZER and MELTZER, xlii.
- MELTZER, S. J., and W. J. GIES. Studies on the influence of artificial respiration upon strychnine spasms and respiratory movements, xlii.
- MELTZER, S. J., and CLARA MELTZER. The vasomotor influence of the third cervical nerve (*auricularis magnus*) upon the circulation in the rabbit's ear, xlii.
- MELTZER, S. J., and CLARA MELTZER. The effect of the intravenous injection of adrenalin upon the blood-vessels of the ear when deprived of their vaso-constrictors, xlii.
- MELTZER, S. J., and CLARA MELTZER. The unmistakable vasomotor influence of subcutaneous injection of adrenalin, xlii.
- MELTZER, S. J., and W. SALANT. The influence of nephrectomy upon absorption, xlii.
- MENDEL, L. B., and F. P. UNDERHILL. New experiments on the physiological action of the proteoses, xvi.
- MENDEL, L. B., F. P. UNDERHILL, and B. WHITE. A physiological study of nucleic acid, 377.
- Metabolism, in salmon before spawning, xlii.
- Milk, coagulation, xxxv.
- , skimmed, food value, 197.
- Moist chamber, xxii.
- Molluscs, rate of nerve impulse, 251.
- Mucoid, xlii.
- Muscle, action of alcohol upon, 61.
- Muscles, classification as flexors and extensors, xxiv.
- , second maximum in response to a series of stimuli, xxiv.
- , heart, affected by sodium chloride, 75.
- , human, "gap" in contraction, 435.
- , human, stimulation with induced currents, 355.
- Muscles, plain, tone affected by salts, 269.
- Muscle lever, heavy, xl.
- Muscle tonus, xxvi.
- Muscles, action upon joints, xxiv.
- Muscular energy, source, xlii.
- N**EPHRECTOMY, influence upon absorption, xlii.
- Nerve impulse, rate, 251.
- Nucleic acid, xlii.
- , action and fate in body, 377.
- Nucleo-proteids, 447, xli.
- , optical properties, 447, xli.
- O**XYPHÆMOGLOBIN, inhibition of crystallization, xlii.
- , quick crystallization, xlii.
- P**EPSIN, action influenced by acids, xxxiv.
- PESKIND, S. Notes on the action of acids and acid salts on blood-corpuscles and some other cells, 99.
- PESKIND, S. The action of acids and acid salts on blood-corpuscles and other cells, 494.
- PORTER, W. T. New inductorium, kymograph, heart lever, heavy muscle lever, and square rheochord, xxxv.
- PORTER, W. T. The tonus of heart muscle, xxvi.
- Potassium cyanide, prolongation of life, 175.
- Potential, differences between blood and serum, etc., xliii.
- Proceedings of the American Physiological Society, ix.
- Protagon of brain, 183.
- Proteid metabolism, specific characters, xxiii.
- Proteid, reaction with chromate, xv.
- Proteolysis influenced by acids, xxxiv.
- Proteoses, physiological action, xvi.
- Protoplasm, contractility affected by ethyl-alcohol, xix.
- , inorganic elements, xlii.
- Protoplasmic activity affected by mechanical shock, 300.
- R**EICHERT, E. T. Inhibitory phenomena in the crystallization of oxyhæmoglobin, xlii.
- REICHERT, E. T. Quick methods for the crystallization of the oxyhæmoglobin of the blood of the dog and certain other species, xlii.
- RETTGER, L. F. An experimental study

of the chemical products of *bacillus coli communis* and *bacillus lactis aerogenes*, 284.
 Rheochord, square, xli.

SALANT, W. See LEE and SALANT, 61.
SALANT, W. See MELTZER and SALANT, xlii.
 Salivary digestion in stomach, xxviii.
 Salmon, changes in the run to the spawning beds, xlii.
SHAFFER, P. On the quantitative determination of ammonia in urine, 330.
 Sodium chloride excretion in urine, 139.
 Sodium chloride retention, 155.
SOLLMANN, T. The mechanism of the retention of chlorides: a contribution to the theory of urine secretion, 155.
SOLLMANN, T. See HATCHER and SOLLMANN, 139.
 Sperm, duration of life in sea-water, 430.
STEWART, C. C. Some minor improvements in laboratory apparatus, xxii.
STEWART, C. C. The second maximum in the response of muscle to stimulation, xxiv.
STEWART, G. N. Differences of potential between blood and serum and between normal and laked blood, xliii.
STEWART, G. N. The action of hæmolytic agents at 0° C., xliii.
STEWART, G. N. The behavior of nucleated colored blood-corpuscles to certain hæmolytic agents, 103.
STILES, P. G. On the influence of calcium and potassium salts upon the tone of plain muscle, 269.
 Stimulator, mercury-mercury, xx.
 —, platinum-mercury, xx.
 Stomach, movements, xxi, xli.
 —, salivary digestion, xxviii.
STOOKEY, L. B. See LEVENE and STOOKEY, xxiii.
STOKEY, T. A. The influence of fatigue upon the speed of voluntary contraction of human muscle, 355.
STOKEY, T. A. Variations in the amplitude of the contractions of human voluntary muscle in response to graded variations in the strength of the induced shock, 435.
 Strychnine poisoning, affected by artificial respiration, xlii.

Suprarenal extract, 441, xli.

—, reducing power, xxx.

Suprarenal gland, xanthin content, xlii.

TASTE fibres, relation to trigeminus, xxvii.

Tone of plain muscle, affected by salts, 269.

Tonus of heart muscle, xxvi.

TOWER, R. W. See GORHAM and TOWER, 175.

Tri-brom-tertiary butyl-alcohol, pharmacological and chemical properties, xviii.

UNDERHILL, F. P. See MENDEL and UNDERHILL, xvi.

UNDERHILL, F. P. See MENDEL, UNDERHILL, and WHITE, 377.

Unicellular organisms, reaction to stimuli, 23.

Urine, constituents affected by diminished excretion of sodium chloride, 139.

—, determination of ammonia, 330.

VASOMOTOR fibres in third cervical nerve, xlii.

Vasomotor phenomena of ear, influenced by adrenalin, xlii.

WALLACE, G. B., and H. C. JACKSON, Is the action of alcohol on gastric secretion specific? xvii.

WHITCHER, B. R. See MATHEWS and WHITCHER, 300.

WHITE, B. See MENDEL, UNDERHILL, and WHITE, 377.

WILDER, B. G. A living frog from which the cerebrum was removed December 4, 1899, xlii.

WILDER, B. G. An improved apparatus for illustrating the action of the diaphragm, xlii.

WILSON, MARGARET B. On the growth of suckling pigs fed on a diet of skimmed cow's milk, 197.

WOODWORTH, R. S. Maximal contraction, "staircase" contraction, refractory period, and compensatory pause, of the heart, 213.

XANTHIN bodies in suprarenal gland, xlii.





BINDING SECT. MAR 4 1966

QP
1
A5
v.8
cop.2 1903

American Journal of Physiology

Biological
& Medical
Serials

PLEASE DO NOT REMOVE
CARDS OR SLIPS FROM THIS POCKET

UNIVERSITY OF TORONTO LIBRARY

STORAGE

