













22

THE AMERICAN JOURNAL  
OF  
PHYSIOLOGY.

NOTE TO BINDER.

The Proceedings of the American Physiological Society, which appeared in the February issue of this journal, have been reprinted in this issue, in order to correct the pagination, which should have been in roman. In binding this volume, binders are requested to use these pages, following the contents.

EDITED FOR

**The American Physiological Society**



THE  
AMERICAN JOURNAL  
OF  
PHYSIOLOGY

VOLUME XXV.

---

102518  
20/6/10

BOSTON, U. S. A.

1909-1910.

QP  
-  
A5  
V.25  
cop. 2

*Copyright, 1909-1910*  
BY THE UNIVERSITY PRESS.

THE UNIVERSITY PRESS, CAMBRIDGE, U. S. A.

# CONTENTS.

## NO. I, SEPTEMBER 1, 1909.

	PAGE
THE PATHS OF EXCRETION FOR INORGANIC COMPOUNDS. — IV. THE EXCRETION OF MAGNESIUM. <i>By Lafayette B. Mendel and Stanley R. Benedict</i>	1
THE PATHS OF EXCRETION FOR INORGANIC COMPOUNDS. — V. THE EXCRETION OF CALCIUM. <i>By Lafayette B. Mendel and Stanley R. Benedict</i>	23
THE INFLUENCE OF THE ISOMERS OF SALICYLIC ACID ON METABOLISM. <i>By Elbert W. Rockwood</i>	34

## NO. II, OCTOBER 1, 1909.

THE INFLUENCE OF CALCIUM UPON THE PUPIL AND THE PUPILLOMOTOR FIBRES OF THE SYMPATHETIC NERVE. <i>By John Auer and S. J. Meltzer</i>	43
CERTAIN ASPECTS OF CARBOHYDRATE METABOLISM IN RELATION TO THE COMPLETE REMOVAL OF THE THYROIDS AND PARTIAL PARATHYROIDECTOMY. <i>By Frank P. Underhill and Warren W. Hilditch</i>	66
THE INTEGUMENTARY NERVES OF FISHES AS PHOTORECEPTORS AND THEIR SIGNIFICANCE FOR THE ORIGIN OF THE VERTEBRATE EYES. <i>By G. H. Parker</i>	77

## NO. III, NOVEMBER 1, 1909.

THE DESTRUCTIVE EFFECT OF SHAKING UPON THE PROTEOLYTIC FERMENTS. <i>By A. O. Shaklee and S. J. Meltzer</i>	81
THE EFFECT OF SUBMINIMAL STIMULATION OF THE PNEUMOGASTRIC NERVES UPON THE ONSET OF CARDIAC RIGOR. <i>By Don R. Joseph and S. J. Meltzer</i>	113
NUCLEIN SYNTHESIS IN THE ANIMAL BODY. <i>By E. V. McCollum</i>	120
THE ELIMINATION OF BARIUM. <i>By Gustave M. Meyer</i>	142
THE NEUROCYTOLOGICAL REACTION IN MUSCULAR EXERTION. I. PRELIMINARY COMMUNICATION. THE SEQUENCE OF THE IMMEDIATE CHANGES IN THE PURKINJE CELLS. <i>By David H. Dolley</i>	151

## NO. IV, DECEMBER 1, 1909.

	PAGE
CONTRIBUTION TO THE PHYSIOLOGY OF LYMPH. — IX. NOTES ON THE LEUCOCYTES IN THE NECK LYMPH, THORACIC LYMPH, AND BLOOD OF NORMAL DOGS. <i>By Benjamin F. Davis and A. J. Carlson</i> . . . . .	173
THE RELATIVE TOXICITY OF VARIOUS SALTS AND ACIDS TOWARD PARAMECIUM. <i>By Lorande Loss Woodruff and Herbert Horace Bunzel</i> . . . . .	190
ON THE NUCLEO-ALBUMEN IN THE YOLK PLATELETS OF THE FROG'S EGG, WITH A NOTE ON THE BLACK PIGMENT. <i>By J. F. McClendon</i> . . . . .	195
THE CATALASE OF ECHINODERM EGGS BEFORE AND AFTER FERTILIZATION. <i>By E. P. Lyon</i> . . . . .	199
THE ELIMINATION OF TOTAL NITROGEN, UREA, AND AMMONIA FOLLOWING THE ADMINISTRATION OF SOME AMINOACIDS, GLYCYLGLYCIN AND GLYCYLGLYCIN ANHYDRID. <i>By P. A. Levene and G. M. Meyer</i> . . . . .	214
THE INFLUENCE OF THE REMOVAL OF SEGMENTS OF THE GASTROINTESTINAL TRACT ON THE CHARACTER OF PROTEIN METABOLISM. <i>By Isaac Levin, D. D. Manson, and P. A. Levene</i> . . . . .	231

## NO. V, JANUARY 1, 1910.

STUDIES IN EXPERIMENTAL GLYCOSURIA. — V. THE DISTRIBUTION OF GLYCOGENOLYTIC FERMENT IN THE ANIMAL BODY, ESPECIALLY OF THE DOG. <i>By J. J. R. Macleod and R. G. Pearce</i> . . . . .	255
A STUDY OF THE CONCENTRATION OF ANTIBODIES IN THE BODY FLUIDS OF NORMAL AND IMMUNE ANIMALS. <i>By J. R. Greer and F. C. Becht</i> . . . . .	292
ACAPNIA AND SHOCK. — IV. FATAL APNŒA AFTER EXCESSIVE RESPIRATION. <i>By Yandell Henderson</i> . . . . .	310
THE EFFECT OF SEVERING THE VAGI OR THE SPLANCHNICS OR BOTH UPON GASTRIC MOTILITY IN RABBITS. <i>By John Auer</i> . . . . .	334

## NO. VI, FEBRUARY 1, 1910.

CONTRIBUTIONS TO THE PHYSIOLOGY OF LYMPH. — X. THE COMPARATIVE ELECTRICAL CONDUCTIVITY OF LYMPH AND SERUM OF THE SAME ANIMAL, AND ITS BEARING ON THEORIES OF LYMPH FORMATION. <i>By A. B. Luckhardt</i> . . . . .	345
CONTRIBUTIONS TO THE PHYSIOLOGY OF LYMPH. — XI. THE FRACTIONAL COAGULATION OF LYMPH. <i>By Herbert O. Lussky</i> . . . . .	354
THE REGENERATION OF NERVE AND MUSCLE OF THE SMALL INTESTINE. <i>Walter J. Meek</i> . . . . .	367
ACAPNIA AND SHOCK. — V. FAILURE OF RESPIRATION AFTER INTENSE PAIN. <i>By Yandell Henderson</i> . . . . .	385

Contents.

vii

NO. VII, MARCH 1, 1910.

	PAGE
THE DEPRESSION OF THE AMMONIA-DESTROYING POWER OF THE LIVER AFTER COMPLETE THYROIDECTOMY. <i>By A. J. Carlson and Clara Jacobson</i> . . .	403
THE ACTION OF THE PROTEINS OF BLOOD UPON THE ISOLATED MAMMALIAN HEART. <i>By L. W. Gorham and A. W. Morrison</i> . . . . .	419
OBSERVATIONS UPON THE BLOOD PRESSURE OF THE SHEEP. <i>By M. Dresbach</i>	433
THE INFLUENCE OF REMOVAL OF FRAGMENTS OF THE INTESTINAL TRACT ON THE CHARACTER OF NITROGEN METABOLISM. — II. THE REMOVAL OF THE SMALL INTESTINES. <i>By A. Carrel, G. M. Meyer, and P. A. Levene</i> .	439
PROCEEDINGS OF THE AMERICAN PHYSIOLOGICAL SOCIETY . . . . .	ix
— — —	
INDEX . . . . .	457



PROCEEDINGS OF THE AMERICAN PHYSIO-  
LOGICAL SOCIETY.

TWENTY-SECOND ANNUAL MEETING.

BOSTON, DECEMBER 27, 28, and 29, 1909.





PROCEEDINGS OF THE AMERICAN PHYSIOLOGICAL  
SOCIETY.

---

THE INFLUENCE OF ALCOHOL UPON METABOLISM.

BY LAFAYETTE B. MENDEL AND WARREN W. HILDITCH.

**THERE** are numerous valuable data on record with reference to the general effects of alcohol on protein metabolism and nutrition in general, but the nature of the toxic action which alcohol may exert is as yet unexplained. The observation of abnormal constituents in the urine in cases of acute and chronic alcoholism makes it desirable to ascertain whether any more specific alterations in the metabolic processes are induced which might give evidence of themselves in changes in the relative participation of various processes in the nutritive exchanges, as, for example, in the partition of nitrogen in the urine. Experiments on men and dogs under fixed conditions of diet with varying doses of alcohol show no noteworthy alteration in the proportions of the different types of nitrogenous excretory products, with the exception of the purine group. The purines, as a rule, are increased in quantity. Smaller doses of alcohol exhibit the well-known protein-sparing effects. Even with comparatively large doses continued for days, further pronounced alterations indicative of markedly disturbed protein metabolism fail to appear. These studies, like numerous others published in recent years, emphasize the capacity of the body to maintain its catabolic functions along certain channels by strictly normal processes, despite the interference of toxic agents — a “factor of safety” being present. In the more marked conditions of alcoholism, conjugated glycuronates may be excreted, both in man and in animals. They disappear rapidly with the cessation of the intake of alcohol. The data here discussed will soon be published in detail.

CONGENITAL THYROIDISM: AN EXPERIMENTAL STUDY  
OF THE THYROID IN RELATION TO OTHER GLANDS  
WITH INTERNAL SECRETION.

By R. G. HOSKINS.

PREGNANT guinea-pigs were treated for various lengths of time with desiccated thyroid gland in various doses. The weights of the individual organs of internal secretion were determined in the offspring and compared with those of normal animals. The results, expressed as percentages of the body weights, were arranged in the order of total dosage. There was noted a progressive diminution in the weights of the thyroids and the adrenals and, doubtfully, of the ovaries. The pituitaries and testes were not demonstrably affected. The thymuses showed marked but not demonstrably progressive hypertrophy.

---

AN OBSERVATION ON THE CHEMICAL REGULATION  
OF RESPIRATION.

By YANDELL HENDERSON.

THE respiratory centre is excited to increased activity by a slight increase of  $\text{CO}_2$  or by a large diminution in the oxygen supply. The former is a direct stimulus, the latter probably indirect. It is supposed to be due to the appearance in the blood of acidosis substances (lactic, and oxybutyric acids, acetone, etc.) resulting from asphyxia of the tissues. The simplest theory to account for both effects is that the chemical regulation of respiration depends upon the acidity (or alkalinity) of the blood, — that is, upon the free  $\text{H}^+$  ions.

The observation to be here reported was made upon dogs. Some were subjected to excessive artificial respiration for twenty minutes. Others were kept in natural hyperpnœa by stimulation of afferent nerves. Both sets developed a considerable acapnia, and sank into apnœa for four or five minutes thereafter. Spontaneous breathing returned, while the  $\text{CO}_2$  content of the blood was still subnormal. Doubtless this premature return of breathing was due to the fact that the anoxhæmia of

the third and fourth minutes of apnœa caused the formation of acidosis substances. First a single inspiratory gasp occurred. This was followed by a *renewal of apnœa* for thirty to forty five seconds. Then two gasps occurred, and apnœa again for thirty seconds. Then three gasps, and so on, through a period of Cheyne-Stokes respiration, passing gradually into normal breathing.

The relapses into apnœa were doubtless due to oxidation of the acidosis substances by the air supplied by the gasps. If blood were mere water, the accumulation of lactic acid during the anoxhæmia of prolonged apnœa might increase the  $\overset{+}{\text{H}}$  ions up to the threshold of the respiratory centre. After the inspiration thus induced, the reaction  $\text{C}_3\text{H}_6\text{O}_3 + 3 \text{O}_2 = 3 \text{H}_2\text{CO}_3$  might occur. The extent of ionization of lactic acid in watery solution is much more than three times that of carbonic acid. Thus the  $\overset{+}{\text{H}}$  ions would be diminished, and apnœa would naturally recur.

But in reality blood is so alkaline that practically all the lactic acid combines, and the oxidation is  $\text{NaC}_3\text{H}_5\text{O}_3 + 3 \text{O}_2 = \text{NaHCO}_3 + 2 \text{H}_2\text{CO}_3$ , and the  $\overset{+}{\text{H}}$  ions are thus considerably increased. Additional spontaneous breathing should follow if respiration depends upon the acidity, but actually apnœa occurs. The observation is, therefore, opposed to the idea that the  $\overset{+}{\text{H}}$  ions are the potent factor in the chemical regulation of respiration.

## APNŒA VERA IN ANÆSTHESIA.

BY M. M. SCARBROUGH (BY INVITATION) AND V. HENDERSON.

THE investigations of Haldane and his co-workers demonstrate that in normal life the  $\text{CO}_2$  content of the blood is maintained within very narrow limits of variation. This regulation depends upon the unvarying level and the sharpness of the threshold (*i. e.*, the sensitiveness) of the respiratory centre for  $\text{CO}_2$ . A slight diminution in the  $\text{CO}_2$  content of the arterial blood produced by a few forced respirations automatically induces apnœa. The addition of 0.2 per cent of  $\text{CO}_2$  to the air breathed doubles the respiratory activity. Day and night, year after year, the threshold is the same.

The threshold may be determined by analyzing the alveolar air of the lungs, or by determining the  $\text{CO}_2$  content of the arterial blood. If under any abnormal condition it is found that respiration is automatically maintaining more or less  $\text{CO}_2$  in the blood than normally, a rise or lowering of the threshold of the centre is demonstrated. The  $\text{CO}_2$  content affords a measure of the threshold.

A table (to be published later in this Journal) of the results of blood gas analyses upon forty dogs under anæsthesia, was shown to the Society. These data show that morphin and chloroform tend to raise the threshold from the normal 40 volumes per cent  $\text{CO}_2$  up to 50 or even 60, while ether tends to lower it from 40 to 35, or even to less than 30 volumes per cent.

The view was advanced that failure of respiration in any stage of anæsthesia is essentially the same reaction on the part of the centre as that occurring when a normal man passes into apnœa vera after forced breathing. Thus chloroform apnœa is merely the sudden raising of the threshold above the quantity of  $\text{CO}_2$  in the blood. After the excessive ventilation and acapnia of ether excitement restoration of a normal threshold by deeper anæsthesia also induces apnœa. The duration of apnœa is determined by the difference between the threshold of the centre and the quantity of  $\text{CO}_2$  in the blood.

---

#### A POSSIBLE SIGNIFICANCE OF THE CAMMIDGE REACTION.

BY L. B. STOOKEY.

SMOLENSKI attributes the Cammidge reaction to saccharose. This led us to think of some intestinal lesion as a possible source of the Cammidge reaction. Two possibilities are evident: (1) absorption of saccharose as such; (2) reversible action of intestinal saccharase.

To test this view the Cammidge test was made on urines in cases of "chronic intestinal disturbance." Twelve cases, in only one of which there was a clinical suspicion of a pancreatitis, were studied. Five gave positive Cammidge reactions. The case showing the most pronounced reaction failed to give the Cammidge test after forty-eight hours' star-

vation. During the twelve hours following starvation a liberal quantity of milk sweetened with levulose was given. This did not lead to a positive Cammidge.

From the experiments made thus far it seems that there may be some relationship between the amount of cane sugar eaten and the intensity of the Cammidge reaction.

---

## THE ABSORPTION OF FLUID FROM THE PERITONEAL CAVITY.

BY MOYER S. FLEISHER AND LEO LOEB.

NEPHRECTOMY, or ligature of the renal vessels, causes increased osmotic pressure of the blood and an increased rate of absorption from the peritoneal cavity; but other operations — as, for instance, an incision into the skin and muscle of the thorax — influence the osmotic pressure of the blood, as well as absorption, approximately in the same way as nephrectomy, although some insignificant quantitative differences may exist. We have not here to deal, therefore, with a specific effect upon the kidney. Narcosis by means of ether alone, however, affects neither the osmotic pressure of the blood nor the rate of absorption.

Adrenalin increases the rate of absorption of a 0.85 per cent NaCl solution, as well as that of a hypertonic (for instance, a 1.5 per cent salt solution); and also the rate of absorption of distilled water. Correspondingly, adrenalin increases the osmotic pressure of the blood. In these latter experiments adrenalin was injected intraperitoneally.

Under the influence of caffeine, the osmotic pressure of the blood of normal animals is not raised, but, rather, somewhat lowered — which is probably due to the increased elimination of NaCl through the kidneys. Correspondingly, we find that absorption of fluid from the peritoneal cavity is not increased under the influence of caffeine. In nephrectomized animals, on the other hand, a noticeable rise in the osmotic pressure of the blood is produced under the influence of caffeine; and, correspondingly, we find that caffeine increases markedly the absorption of fluid from the peritoneal cavity. We notice, thus, an inverse action of caffeine upon the absorption of fluid and upon diuresis.

These experimental conditions influence not only the distribution of

fluid in the body, but also the distribution of the chlorides and of other osmotically active substances; and these changes do not usually take place in a parallel direction.

## MAMMALIAN HEART STRIPS TOGETHER WITH A THEORY OF CARDIAC INHIBITION.

BY JOSEPH ERLANGER.

A THEORY of so-called inhibition of the heart, which might be considered a modification of Budge's, suggested itself to the author in the course of his work on heart block. The results of a study of isolated strips of mammalian auricle served to strengthen his belief in this theory in that the facts brought to light in this study, as well as most of those already on record, seem to be satisfactorily explained by it.

It is assumed that the inner stimulus of the heart is discontinuous, and that its period of discharge, like that of nerve cells, nerve fibres, and cross-striated muscle, is short, perhaps 10-50 per second. The inner stimulus normally develops in the most rhythmical parts of the heart, probably the two *Knoten* together with the connections between them and the auriculo-ventricular bundle system. It is further assumed that the impulses carried into the heart by the vagi, like all other continued stimuli, act first and mainly upon the most rhythmical, *i. e.*, normally the upper parts of the conducting system to increase the rate of their rhythm. The heart tissue proper responds in partial block to this rapid rate of stimulation. Thus results the normal rate of heart beat. An increase in the rate of discharge of the hypothetical cardiomotor centre, such as would result from vagus stimulation, would, as does a simple increase in the rate of the auricles in partial heart block, slow the rate or even lead to stoppage of the parts of the heart dependent upon it for their pace. By this mechanism most of the chronotropic and dromotropic effects of vagus stimulation may be accounted for. The negative inotropic effects are explained as being due in part to the failure of the feebler impulses from the hypothetical cardiomotor centre to stimulate all of the muscle fibres, in part to the reduced reactivity in the parts of the heart which are not beating at their optimum rate. To the latter factor also may be ascribed the inconstant bathmotropic effects of vagus stimula-

tion. The change from negative to positive influences with cessation of vagus stimulation is explained as being due in part at least to the increased strength of the impulses sent out by the cardiomotor centre whose activity has been increased by excitation through the vagi.

---

### SOME OBSERVATIONS UPON THE BLOOD PRESSURE OF THE SHEEP UNDER LOCAL AND GENERAL ANÆSTHESIA.

By M. DRESBACH.

THE experiments described in this paper indicate that the mean carotid pressure in the sheep is about 110 mm. mercury, when measured carefully under local anæsthesia. In six sheep it ranged from 100 to 115 mm. These figures are much lower than those usually given in the literature. The latter are determinations made before anæsthetics were in use and are probably inaccurate.

The experiments of the writer show that blood pressure measurements made under chloroform or ether in the sheep are likely to vary greatly in different subjects. The sheep is very easily depressed, especially by chloroform, and in severe operations may suffer profoundly from "shock." Cheyne-Stokes respiration very often occurs. Stimulation of the vagus inhibits the heart only partly. In the present work complete inhibition was obtained in two out of eight sheep.

---

### THE MUTUAL ANTAGONISTIC LIFE-SAVING ACTION OF BARIUM AND MAGNESIUM.—A DEMONSTRATION.

By DON R. JOSEPH AND S. J. MELTZER.

FOR rabbits, 1.2 gm. of magnesium sulphate per kilo body-weight are invariably fatal in intramuscular injection; the rabbits die usually in less than twenty minutes. The rabbit to the right (*A*) received such a dose and has been dead for some time. The rabbit in the middle (*B*) received a similar dose of magnesium and is still alive; it breathes regularly. This animal received also an intravenous injection of barium chloride which is the

cause of its surviving the fatal dose of magnesium. By a special study we are enabled to state the mode of the antagonistic action of barium, which is this: the fatal action of magnesium is due to a paralysis of respiration, and barium counteracts just this effect of magnesium. It differs from the antagonistic action of calcium inasmuch as calcium antagonizes all the effects of magnesium, while barium picks out only the respiration, the animal remaining anæsthetized and paralyzed.

This surviving rabbit (*B*) illustrates, however, also another result. The rabbit to the left (*C*) is dead from a dose of barium chloride similar to the one administered to the surviving animal (*B*). This means that the magnesium antagonizes the fatal effect of barium. We are not ready to state definitely in what way this action of magnesium is exerted. The poisonous effect of barium is due to its action upon various functions, and the magnesium antagonizes some of them.

---

## THE EFFECT OF VARYING ROOM TEMPERATURES UPON THE PERIPHERAL BLOOD FLOW.

BY A. W. HEWLETT.

THE rate of blood flow in the arm of man under varying room temperatures was studied by a modified Brodie method. Individuals stripped to the waist were placed in a room cooled to about 18° C. and the room was heated by gas stoves. Slight chilliness was soon followed by a comfortable feeling, and the heating was continued until the first signs of perspiration appeared (usually at about 30° C.). The flow of blood in the arm remained approximately constant up to the point where the individual began to feel decidedly warm. It then increased rapidly and usually reached about five times the previous rate by the time that the first visible perspiration appeared. Cooling a room from a comfortable temperature to a point where the individual was decidedly chilly reduced the peripheral flow about one half. These changes occurred rapidly where the person passed from a warm to a cold room or *vice versa*.



THE PRODUCTION OF SUGAR FROM AMINO-ACIDS.

BY A. I. RINGER (BY INVITATION) AND GRAHAM LUSK.

VARIOUS amino-acids were given to dogs with total phlorhizin glycosuria. The results show that both glycocoll and alanin may be completely converted into sugar, and that three carbon atoms of the four which are contained in aspartic acid and also three of the five contained in glutamic acid are convertible into dextrose. The results are given in the following table:

RESULTS IN GRAMS AFTER INGESTION OF 20 GRAMS OF SUBSTANCE.					
		Glycocoll.	Alanin.	Aspartic Acid.	Glutamic Acid.
N ingested . . .	{ a . . . . .	3.77	3.12	2.14	1.95
	{ b . . . . .	3.77	3.12	2.14	1.95
Extra dextrose eliminated	{ a . . . . .	13.97	18.76	11.32	13.09
	{ b . . . . .	15.71	18.78	12.26	13.46
THEORETICAL GRAMS OF DEXTROSE THAT MIGHT BE MADE FROM:					
2 C atoms . . . . .		16	....	9.02	8.16
3 C atoms . . . . .		....	20.2	13.56	12.24
4 C atoms . . . . .		....	....	18.04	16.32
5 C atoms . . . . .		....	....	....	20.40

ON THE DISTRIBUTION OF IMMUNE BODIES IN THE BODY FLUIDS OF IMMUNE ANIMALS.

BY L. HEKTOEN AND A. J. CARLSON.

I. IN active immunity in dogs produced by intravenous injection of goat's erythrocytes the immune bodies (hemolysins, hemagglutinins, hemopsonins) reach their highest concentration in the blood. They are

uniformly slightly less concentrated in the thoracic lymph and the neck lymph, while in the cerebro-spinal fluid only traces of the lysins and the opsonins can be detected at the height of immunity. This distribution of the immune bodies obtains at all stages of the immunity reaction. In dogs immunized to rat's erythrocytes the opsonins in the cerebro-spinal fluid run parallel with those of the blood and the lymphs, but the concentration in the cerebro-spinal fluid is lower than in the other fluids.

2. On transfusion of blood of immune dogs into normal dogs previously bled dry through the carotid artery the immune bodies can be detected in the lymphs of the recipient in ninety minutes after transfusion, and eventually the same relative distribution of the antibodies is effected as in active immunity. It seems therefore probable that this distribution in active immunity depends on the equilibrium relation between the blood and the lymph rather than upon the place of formation of the immune bodies.

The rate of passage of the antibodies from the blood to the lymph is probably in part a function of this concentration in the blood. There appears to be no difference in the rate of passage in the various immune bodies from the blood to the lymph, but our methods would not disclose slight variations.

3. When the blood of an immune animal is transfused into a normal animal previously bled dry, there is a rapid fall in the concentration during the first twenty-four hours, due in all probability to the dilution with the lymph in the vascular system and the passage into the tissue and the lymphatic lymphs. Then follows a more gradual disappearance of the immune bodies until the normal limit is reached in twenty to thirty days.

The duration of the passive immunity after as complete transfusion as possible depends directly on the concentration of the immune bodies in the donor's blood and the quantity of this blood transfused, that is to say, on the degrees of the passive immunity and not on the stage of the immunity reaction in the donor.

In passive immunity the rate of diminution in the concentration of the immune bodies after the first ten to twenty-four hours is a measure of the rate of destruction and elimination of these bodies, as there is no production of antibodies in the transfused blood.

4. Bleeding the immune animal dry by the carotid artery and transfusion into him of blood from a normal dog has no effect on the im-

munity reaction if done in a period of three to forty-eight hours after immunization. When done at later periods, there is a temporary diminution in the immune bodies, by dilution with the normal blood. These facts seem to show that the antigens of goat's erythrocytes are rapidly taken out of the circulating blood, and that the formed elements of the blood take no obvious part in the fixation of the antigens or in the production of the antibodies.

5. Transfusion of the blood of an animal immunized with an optimum dose of antigens into a normal animal previously bled dry by the carotid artery produces no immunizing reaction in the recipient, if the transfusion is made after the antigens have become fixed and before the immune bodies appear in the body fluids, that is, three to forty-eight hours after immunization. If the transfusion is made later, the result is simply the passive immunity referred to above. This is additional evidence that the blood takes no direct or necessary part in the fixation of the antigens or the production of the immune bodies.

---

## THE RELATION OF THE PANCREAS TO SUGAR METABOLISM.

By WESLEY M. BALDWIN.

THIS paper is a preliminary communication dealing with some experiments performed in the laboratories of the department of physiology of the Cornell University Medical College at Ithaca, N. Y., preparatory to a study of the relation of the function of the islands of Langerhans to sugar metabolism in general and to the glycogenic function of the liver in particular.

An adult cat was instantaneously killed by mechanical violence, and its muscles and pancreas removed immediately to a cold storage vault of a temperature of  $-7^{\circ}$  C. Subsequently they were frozen brittle with liquid air and pulverized in an iron mortar. This pulverization was so thorough that only with difficulty could any cell structure be recognized under the microscope. This mass was then thawed out, expressed in a meat press, and 167.0 gm. of muscle and 1.67 gm. of pancreas freely diluted with toluol. The solution was then placed in an oven with a continuous temperature of  $39^{\circ}$  C. and treated with 1.0 gm. of glucose. A

stream of air was passed through the mixture continuously. Faint alkalinity was maintained by the frequent addition of a 0.5 per cent solution of sodium bicarbonate. At the end of twenty-four hours the quantity of glucose present was ascertained by the Pavy method to be 0.02 gm., 0.08 gm. of glucose having disappeared. Several control experiments were made to determine the accuracy of the Pavy method and also the actual quantity of glucose present in the solution at the beginning of the experiment. Furthermore, at the close of the "run" another gram of glucose was added to the solution and the experiment conducted as before for twenty-four hours longer. The addition of the alkaline sodium bicarbonate solution was found to be unnecessary, since the mixture did not become acid, and at the completion of the "run" the glucose was found to have suffered no reduction in quantity.

Cohnheim had remarked that muscle and pancreas together destroyed sugar. These preliminary experiments seem to corroborate his statement.

---

#### THE SENSITIZING AND DESENSITIZING ACTION OF VARIOUS ELECTROLYTES ON MUSCLE AND NERVE.

By R. S. LILLIE.

A FROG'S gastrocnemius (either normal or curarized) transferred from Ringer's solution to an isotonic ( $m/8$ ) solution of NaI shows an immediate increase of tone, and usually begins at once a slight or moderate rhythmical twitching which continues during the stay in the solution. On return to Ringer's solution prompt relaxation follows and the twitching ceases. If then the muscle is immersed for a brief period — *e. g.*, three minutes — in a pure isotonic solution ( $m/8$ ) of NaCl, and is then brought again into  $m/8$  NaI, a much more energetic response than before is invariably found; rapid and pronounced rise of tone with vigorous twitching immediately follows: return to Ringer's solution produces relaxation as before and restores the original condition of irritability. A similar reversible sensitizing action is shown by isotonic solutions of other sodium salts and to a less degree by lithium salts. The action varies with the length of the exposure to the solution and with the nature of the anion: bromide and sulphocyanate have in general — for brief exposures of equal length — a greater effect than chloride, nitrate, or chlorate; in

solutions of sodium acetate, tartrate, and sulphate active twitching is seen from the first, and the contractions on immersion in iodide solution are especially energetic.

Brief exposure — two to three minutes — to  $m/8$   $MgCl_2$ ,  $CaCl_2$ , or  $SrCl_2$  greatly diminishes or altogether suppresses the response to  $m/8$   $NaI$ . A similar desensitizing action is shown by weak solutions of acid ( $n/500$  to  $n/1000$   $HCl$  in Ringer's solution). Alkali in the same concentrations has the opposite effect, increasing the height of the contractions in  $m/8$   $NaI$ .  $BaCl_2$  differs from the other alkali earth chlorides in showing marked sensitizing action.

With nerve (sciatic of frog) conditions essentially similar to the above have been found, although to produce a decided sensitization a longer immersion in the solutions is usually required. The sensitized state also persists longer in nerve than in muscle after return to Ringer's solution.

The characteristic variation in the effect with the nature of the anion indicates a colloid action as the basis of the sensitizing influence. Since the above salts penetrate the living cell very slowly if at all, their point of action must be *superficial*. The plasma membrane of the irritable element is thus indicated as the structure primarily affected; this membrane is presumably modified in such a manner as to alter the readiness with which changes in its permeability are effected; hence stimulation — which appears to involve an increase in permeability — is facilitated or hindered according to the mode of action of the solution.

Experiments on the influence of other electrolytes and of lipid solvents and alkaloids are in progress.

---

## THE ACTION OF ISOTONIC SOLUTIONS OF NEUTRAL SALTS ON UNFERTILIZED ECHINODERM EGGS.

By R. S. LILLIE.

UNFERTILIZED sea-urchin eggs (*Arbacia*) placed in pure solutions of neutral salts of alkali metals isotonic with sea water undergo after an interval loss of pigment and eventually disintegration. The following is the order of relative effectiveness for sodium salts with monovalent anions:  $NaCl$  and  $NaBr < NaNO_3 < NaCNS < NaI$ . Potassium salts show a slower action but follow the same general order. The loss of

pigment is an effect analogous to hæmolysis and indicates an increase in the permeability of the plasma membrane.

If eggs, after a relatively brief exposure (five to twenty minutes) to the action of these solutions, are transferred to normal sea water, a considerable proportion, especially in solutions of nitrate, sulphocyanate, and iodide, undergo irregular form-changes and cleavage, and a smaller proportion develop to a free-swimming blastula stage. The order of relative favorability for the different salts is the same as above. This result confirms the view that the primary change in the initiation of cell division is an increase in the permeability of the plasma membrane.

The above order is also that of relative toxicity: the toxic effect is to be attributed to a loss of diffusible cell-constituents through the altered plasma membrane. Increase of permeability beyond a certain degree thus involves destruction of the chemical organization of the cell. The exit of pigment is merely a visible instance of such loss of material.

---

### THE EFFECT OF EXERCISE UPON THE VENOUS PRESSURE.

BY D. R. HOOKER (WITH J. M. WOLFSOHN).

MUSCULAR exercise (stationary bicycle) causes a rise of venous pressure in the hand. If during the exercise the respiration is markedly increased, the rise of pressure is slight; if the respiration is not much affected, the rise may be as much as 14 centimetres.

Under normal conditions, with the body in the vertical position, the pressure in the veins of the foot is always negative. The muscles of the legs, therefore, and possibly the movements of the joints, must co-operate in raising the venous column to the heart level. That muscular and joint movements are the only factors thus co-operating with the force of the arterial stream in accomplishing the venous circulation of the legs, is indicated by the following observations. With the body horizontal, the pressure in the foot may reach a positive value, but in no case was it found to equal the pressure in the hand. In cases, however, in which the play of the leg muscles and joints were completely excluded by paralysis or anaesthesia, the pressures in the veins of the hand and foot were equal.

THE GASEOUS METABOLISM OF THE DOG'S HEART  
DURING VAGUS INHIBITION.

BY J. M. WOLFSOHN AND L. W. KETRON.

SPECIMENS of blood were taken from the left coronary vein of a dog's heart by means of a syringe before, during, and after vagus stimulation. They were transferred at once to the vacuum tubes of a Hill pump, defibrinated with mercury, and weighed. The results of the analysis of the gases collected over mercury confirm in general those obtained by Barcroft and Dixon in showing that during vagus inhibition there is a diminution in the oxygen absorbed and in the carbon dioxide eliminated, the diminution in the carbon dioxide output being more marked than the decrease in oxygen intake. Examples follow:

I.					
Stimulation.	Wt. of blood.	C.c. of CO <sub>2</sub>	Per cent of CO <sub>2</sub>	C.c. of O <sub>2</sub>	Per cent of O <sub>2</sub>
Before stimulation . . .	12.2	4.7	38.5	1.34	11
During stimulation . . .	11.0	3.69	33.6	1.25	11.5
After stimulation . . . .	9.5	4.49	38.9	1.03	10.8
II.					
Before stimulation . . .	12.05	4.12	34.2	1.3	10.8
During stimulation . . .	10.9	3.49	32.1	1.1	11.2
After stimulation . . . .	11.95	4.18	35	1.26	10.6
III.					
Before stimulation . . .	10.8	3.9	36.1	1.2	11.1
During stimulation . . .	8.2	2.6	32.1	1.02	12.4
Before stimulation . . .	10.85	3.9	35.9	1.3	11.9
During stimulation . . .	9.0	2.25	32.9	1.1	12.1

It may be concluded from these results that during vagus inhibition there is no accumulation of carbon dioxide in the heart tissue, but on the contrary there is a diminution in the processes of physiological oxidation.

---

## THE ENERGY METABOLISM OF PARTURIENT WOMEN.

BY THORNE M. CARPENTER AND JOHN R. MURLIN.

EXPERIMENTS designed to compare the energy metabolism of mother and child just previous to and immediately following parturition were carried out with the bed calorimeter. Three subjects were secured through the out-patient department of the McLean Lying-in Hospital. They were cared for in the New England Deaconess Hospital near the laboratory, and were kept on a carefully regulated diet which, except for the day of parturition and one or two days thereafter, was essentially the same throughout for each case. Early in the morning, before breakfast was taken, the subject was brought to the laboratory (in an ambulance when necessary) and was placed in the calorimeter for a period of two or three hours, during which hourly determinations of the carbon dioxide output, the oxygen absorption, the heat elimination, and the heat production were made.

The heat production was calculated also by the Zuntz method from the amount of nitrogen in the urine, the carbon in the expired air, and the oxygen absorbed. A very satisfactory agreement was found between the two methods.

Two of the subjects were primiparæ, and one was a multipara. In both primiparæ the heat production of mother and child was found to be slightly larger just previous to parturition than it was after the temperature had returned to normal following parturition. In the multipara it was slightly higher following parturition than before. The results, therefore, are in sharp contrast with results obtained by one of us<sup>1</sup> (M.) on the dog where the heat production as calculated from the excreta was found to be very much greater following birth of the young.

The heat production of the mother alone was found by direct determination and that of the child by difference. The three cases agree in

<sup>1</sup> *Proceedings of the American Physiological Society*, This journal, 1909, xxiii, p. 32.



showing a heat production per kilogram per hour for the child approximately two and a half times that of the mother under the same conditions.

### WHY DO TEMPERATURE COEFFICIENTS OF PHYSIOLOGICAL PROCESSES INCREASE FOR THE LOWER RANGES AND DECREASE FOR THE HIGHER RANGES OF TEMPERATURE?

BY CHARLES D. SNYDER.

ONE of the characteristics of velocity coefficients for living processes is the fact that for lower ranges of temperature higher coefficients, for higher ranges lower coefficients, are invariably obtained.

Trautz (1909) shows that this tendency also characterizes coefficients for the velocities of saponification of ester with aqueous alkali.

Bearing upon these facts, I wish to report some results of further work on the problem which presents itself.

The latent period of contraction of turtle's ventricular apex at 0° is two seconds, at 30° it is six one hundredths of a second; the shortening phase at 0° is about fourteen seconds, at 30° about eight tenths of a second.

Trautz ascribed this variation of the coefficients for saponification of ester to increasing viscosity of solvent. The "notch" in the curve at  $\frac{t_0}{t_{10}}$  degrees may be connected by the density change of water between 10° and 0°.

Temperature coefficient (Q) for	Q 0°-10°	Q 5°-15°	Q 10°-20°	Q 15°-25°	Q 20°-30°	Q 25°-35°
Time of latent period of turtle's vent. Apex	5.0	3.0	2.8	2.6	2.3	1.3
Time of shortening phase of turtle's vent. Apex	3.5	2.5	2.4	2.2	....	....
Rate of plasmolysis in stems of Sambucus nigra (van Rysselberghe)	3.5	3.3	1.8	1.2	1.1	....
Saponification of ethyl lactate (Ewart)	1.96	....	2.04	....	1.9	(1.75)
Viscosity of egg-white (Ewart)	1.4	1.3	1.2	....	1.2	(1.14)
Viscosity of castor-oil (Arndt)	2.5	2.46	....	2.3	....	(1.9)

Sutherland (1908) ingeniously ascribed the temperature coefficients obtained for nerve to viscosity changes. It remains to be shown experimentally that nerve conduction is "propagation of shear" in the nerve substance (Sutherland).

The above considerations lead me to propose, as a part of this work, an exhaustive study of the temperature coefficients of the viscosities of tissue and body fluids.

### THE ABSORPTION OF FAT STAINED BY SUDAN III.

By R. H. WHITEHEAD.

THIS paper is presented in order to clear up certain points in the account of an experiment undertaken as a demonstration of the common belief that fat is not absorbed unsplit,<sup>1</sup> which account seems to have been open to misapprehension.

1. I was fully aware that Sudan III is absorbed, having seen Dr. Gage's striking preparations at the Baltimore meeting of the Association of American Anatomists. But his paper did not appear until after mine was in press, and thus I could only refer to the meeting. However, the very fact that this dye is absorbed was my reason for employing it. For, I reasoned, if an absorbable dye so freely soluble in fat be introduced with fat into the intestinal canal, the absence of stained granules in the villi would constitute fair proof that fat is not absorbed unsplit. But I had no interest at the time in the absorption of Sudan III *per se*, except in so far as it might, or might not, be carried in by unsplit fat. As a matter of fact, microscopical examination of frozen sections of the intestine revealed no red globules in the epithelium and lacteals of the villi. That, however, fat had been absorbed in some form could be demonstrated by subsequent staining of the sections with Sudan III.

2. The failure to observe pink material in the lymphatics of the mesentery may have been due, as has been suggested, to post mortem contraction of those vessels. At the time I supposed that it was accounted for by the early stage of digestion at which the examination was made. A subsequent experiment upon a living cat leads me to believe

<sup>1</sup> R. H. WHITEHEAD: A note on the absorption of fat, *This journal*, May, 1909.

that it was due both to the early stage of digestion and to the small quantity of material present: a *small* quantity of fat given to a *fasting* animal produced so little chyle that the vessels were not distinct.

3. My remarks as to the form in which the fat was actually absorbed in the experiment were merely an attempt to bring the findings into accord with the current views of physiologists. I knew that there was reason to believe that fatty acids may be absorbed in solution; but it seemed that the fact that the sections lost their pink color in 80 per cent alcohol, and the further fact that a soap made with oleic acid and sodium appeared to dissolve the dye feebly were opposed to that form of absorption in the particular case, and that the presumption was in favor of soap. The point, however, seemed to me immaterial to what I was trying to demonstrate; for in either event, whether the fat was absorbed as fatty acid or as soap, it had been split. I have no desire to insist upon the presumption, but merely wish to bring out the main contention in my note, which was that the experiment afforded a demonstration, histological of course, that the fat was not absorbed in the form of unsplit, emulsified fat.

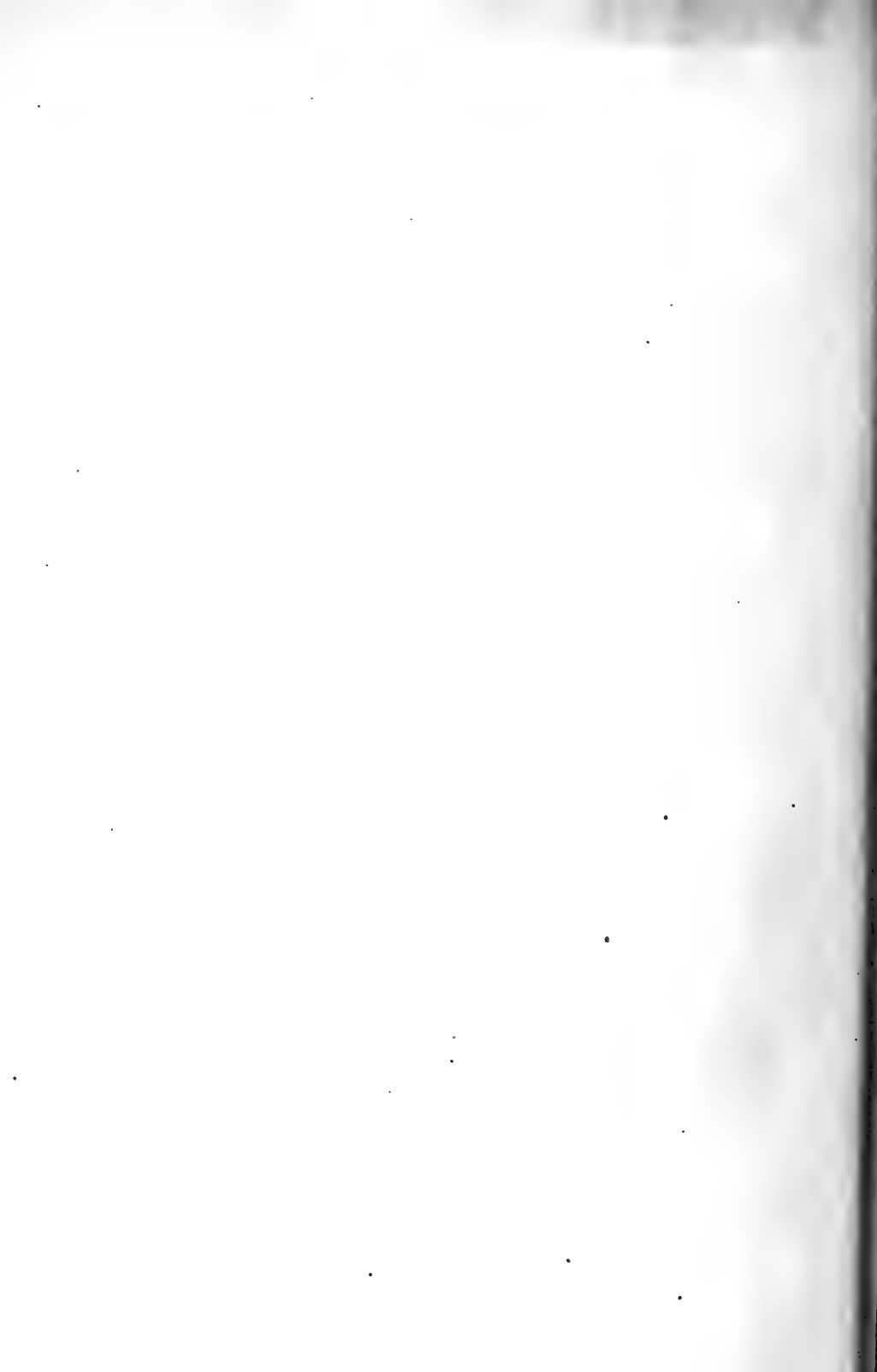

THE  
American Journal of Physiology.

VOL. XXV.

SEPTEMBER 1, 1909.

NO. I.

---

THE PATHS OF EXCRETION FOR INORGANIC COMPOUNDS.—IV. THE EXCRETION OF MAGNESIUM.

BY LAFAYETTE B. MENDEL AND STANLEY R. BENEDICT.

[From the Sheffield Laboratory of Physiological Chemistry, Yale University.]

IT is now recognized that the study of the distribution of certain compounds between the urine and fæces may, under ordinary conditions of intake, give an inadequate and even incorrect idea of the paths through which familiar elements concerned in metabolism leave the tissues and fluids into which they have once entered. We know that the intestine can function as an excretory organ for various types of compounds; accordingly the appearance of an element in the fæces may be explained by a failure to be absorbed from the digestive tube, by excretion into the gut after previous absorption therefrom, or by elimination through this channel, whatever the mode of introduction. When substances are introduced into the body parenterally, *i. e.*, with avoidance of the alimentary tract, an opportunity is offered to study the elimination problems in somewhat more satisfactory ways. Attempts in this direction have previously been reported and discussed.<sup>1</sup>

Numerous investigations are recorded in which intake and output of magnesium have been compared, and the distribution of this

<sup>1</sup> Cf. MENDEL and THACHER: This journal, 1904, xi, p. 5; MENDEL and SICHER: *Ibid.*, 1906, xvi, p. 147; MENDEL and CLOSSON: *Ibid.*, 1906, xvi, p. 152; HANFORD: *Ibid.*, 1903, ix, p. 214, for experiments from this laboratory. See also the discussion by MEYER: Journal of biological chemistry, 1907, ii, p. 461; MELTZER and LUCAS: Journal of experimental medicine, 1907, ix, p. 298.

element in the excreta ascertained. Upon the basis of data thus derived, the current statements regarding the paths of elimination of magnesium are for the most part founded.<sup>2</sup> One finds frequently quoted a statement of Friedrich Müller<sup>3</sup> that much the greater part of the calcium is excreted through the intestinal wall, whereas the magnesium is eliminated in the urine. If the experiments of other investigators are drawn into comparison, it will be seen that any broad generalizations derived from published observations, even for a single species, rest upon uncertain ground. The data in Table I are taken from a compilation by Renvall.<sup>4</sup>

TABLE I.  
SHOWING PERCENTAGE DISTRIBUTION OF MAGNESIUM OUTPUT.

Subject.	Urine.	Fæces.	Investigator.
Man . . . . .	38.6	61.4	Bertram
Dog . . . . .	64.8	35.2	Heiss
Goat . . . . .	31.5	68.5	Bertram
Sheep . . . . .	23.7	76.3	Henneberg
Infant (natural food) . . . . .	47.1	59.2	Blauberg
Infant (cow's milk) . . . . .	6.9	93.1	Blauberg
Infant (cereal preparation) . . . . .	5.3	94.7	Blauberg
Infant (cow's milk) . . . . .	28.3	71.7	Blauberg
Horse . . . . .	32.0	68.0	Tangl <sup>1</sup>

<sup>1</sup> These figures were calculated from data by TANGL: *Archiv für die gesammte Physiologie*, 1902, lxxxix, p. 227.

<sup>2</sup> We shall not attempt a detailed review of the literature on the metabolism of magnesium. Numerous references will be found collected in ALBU and NEUBERG: *Physiologie und Pathologie des Mineralstoffwechsels*, 1906, p. 129, and in papers which will be mentioned elsewhere in this contribution.

<sup>3</sup> MÜLLER: *Zeitschrift für Biologie*, 1884, xx, p. 355. It appears, from a study of this paper, that the author's conclusion, in so far as his own researches are involved, was derived from analytic data furnished by a comparison of the magnesium content of food and fæces (in the dog). The urine itself was apparently not examined directly to verify the inference. HEISS: *Zeitschrift für Biologie*, 1876, xii, p. 151, has furnished such data.

<sup>4</sup> RENVALL: *Skandinavisches Archiv für Physiologie*, 1904, xvi, p. 118.

Goitein<sup>5</sup> fed rabbits on diets containing widely varying quantities of magnesium and calcium. The irregularities likewise noted in such studies are exemplified in the following protocol in Table II:

TABLE II.

DISTRIBUTION OF MAGNESIUM IN ENCRETA OF RABBIT III. (FROM GOITEIN.)

Daily intake of Mg in mgm. . . . .	7	13	16	22	23	27	29	54	
Output (intake = 100) {	in fæces . . . . .	45	32	100	100	35	35	118	42
	in urine . . . . .	35	5	80	70	18	90	24	24

Another series of experimental data indicating the uncertainty attached to the current method of study is furnished by carefully conducted investigations on the calcium and magnesium balances in dogs, from the laboratory of Professor Röhmann in Breslau. The animals were fed upon diets of pure foodstuffs and inorganic salts. Let us compare some of the protocols (Table III):<sup>6</sup>

TABLE III.

MAGNESIUM BALANCES IN DOGS. (GOTTSTEIN.)

	1	2	3	4	5	6	7
Output in urine (gm.) . . . . .	0.0164	0.0426	0.0760	0.2665	0.0399	0.1367	0.1026
Output in fæces (gm.) . . . . .	0.0451	0.0517	0.0214	0.1133	0.4344	0.0325	0.0280
Total . . . . .	0.0615	0.0943	0.0974	0.3798	0.4743	0.1692	0.1306
Intake in food (gm.) . . . . .	0.0070	0.0262	0.0470	0.0468	0.0468	0.1276	0.1347
Mg balance (gm.) . . . . .	-0.05	-0.07	-0.05	-0.33	-0.43	-0.041	+0.004
Intake per day and per kgm. dog (mgm.) . . . . .	0.09	0.32	0.47	0.49	0.49	3.6	5.2

It will be noted that in three of the seven experiments (1, 2, 5), the output of magnesium with the fæces is larger than that in the urine. An instructive comparison can be drawn between 4 and 5. The intake of magnesium was alike in these two experiments; the magnesium balance was quite comparable, yet the predominant

<sup>5</sup> GOITEIN: *Archiv für die gesammte Physiologie*, 1906, cxv, p. 118.

<sup>6</sup> The figures are taken from the Inaugural Dissertation of GOTTSTEIN: *Ueber das Verhalten von Calcium und Magnesium in einigen Stoffwechselversuchen mit phosphorhaltigen und phosphorfreen Eiweisskörpern*. Breslau, 1901. Cf. also LEIPZIGER: *Archiv für die gesammte Physiologie*, 1900, lxxviii, p. 402; EHRLICH: *Inaugural Dissertation*, Breslau, 1900.

paths of elimination *appear* to be reversed in the two cases. It may be remarked that the diet was radically different. Thus in 4 casein (rich in phosphorus) was fed, whereas in 5 phosphorus-free edestin furnished the protein. Moreover, in the similar edestin experiment, 3, reversed relations pertain, in comparison with 5.

Renvall<sup>7</sup> has determined the distribution of excreted magnesium in the same man under varying conditions of magnesium intake (Table IV):

TABLE IV.  
DISTRIBUTION OF MAGNESIUM OUTPUT IN MAN. (RENVALL.)

Intake in gm. . . . .	0.412	0.499	0.559	0.621	0.625
Output in urine in per cent . . .	32.7	28.9	29.8	34.2	30.1
Output in fæces in per cent . . .	67.3	71.1	70.2	65.8	69.9

In the case of infants the preponderance of the loss through the intestinal path has been demonstrated by Blauberg<sup>8</sup> and by Birk.<sup>9</sup> The possibility of direct excretion through the intestinal wall or digestive secretions can be regarded as proved only where the output in the fæces alone far exceeds the intake.

The evidence thus far furnished by the oral administration of pure magnesium salts in large doses is likewise inconclusive. Yvon<sup>10</sup> found an increase in the magnesium output in the urine, amounting to less than 5 per cent of the quantity taken, after administration of 20 gm. of the sulphate to a man. This occurred within the first day, with no appreciable subsequent increase. When the magnesium was taken in the form of the less soluble oxide, the increase in urinary elimination reached somewhat over 8 per cent in all, during a period of several days. One naturally assumes that very little of these salts was absorbed. On the other hand, Hertz, Cook, and Schlesinger<sup>11</sup> assert that in man magnesium sulphate taken *per os* is presumably absorbed into the blood and re-excreted into the gut.

"The fæces and urine were analyzed after magnesium sulphate had been given, and the result compared with the control analyses made on the previous

<sup>7</sup> RENVALL: Skandinavisches Archiv für Physiologie, 1904, xvi, p. 120.

<sup>8</sup> BLAUBERG: Zeitschrift für Biologie, 1900, xl, p. 1.

<sup>9</sup> BIRK: Jahrbuch für Kinderheilkunde, 1907, lxvi, p. 300.

<sup>10</sup> YVON: Archives de physiologie, 1898, xxx, p. 304.

<sup>11</sup> HERTZ, COOK, and SCHLESINGER: Proceedings of the Royal Society of Medicine, 1908, ii, No. 2 (therapeutical and pharmacological section), p. 23.



day. . . . It was found that the watery stool, passed one or two hours after a drachm of magnesium sulphate had been taken in half a pint of water, contained only a few grains more of the salt than the stool which had been passed earlier in the morning, immediately before the salt had been taken. . . . No more feces were excreted until the next morning, when a normal solid stool was passed. This was found to contain a distinctly larger quantity of magnesium sulphate than the more watery stool of the previous day. . . . As the magnesium sulphate did not act from the lumen of the gut, it must have acted from the blood. . . . The greater part of the excess was probably a result of the excretion into the lower end of the colon of some of the magnesium sulphate absorbed from the upper part of the small intestine, *as it is well known that more of the salt is excreted by the mucous membrane of the large intestine than by the kidneys when it is injected into the blood.*<sup>12</sup> A comparison between analyses of the urine passed on the day on which the magnesium sulphate was taken and that passed on the previous day showed that there was already an increase . . . in the total quantity of the total sulphate present in the urine in the four hours following the administration of the salt. . . . Only a small proportion of the magnesium sulphate present in the blood is excreted in the urine.”

Enough has been presented to show the inconclusive character of the accumulated evidence regarding the excretion of *absorbed* magnesium compounds. Meltzer<sup>13</sup> and his collaborators have published results obtained by biological methods to attest the preëminent share of the kidneys in the elimination of magnesium salts. They have shown that in nephrectomized rabbits the susceptibility to the anæsthetic and toxic effect of magnesium salts is decidedly increased, and the profound anæsthesia produced by them may thus be markedly prolonged when kidney elimination is excluded. An experiment on a dog by Steel<sup>14</sup> gives similar indications. After intravenous injection of 8.5 gm. of magnesium sulphate there was only an insignificant increase in the output of magnesium per rectum.

<sup>12</sup> The italics are ours. We are not familiar with any experimental data to justify this conclusion. Those of the authors have not yet been published.

<sup>13</sup> MELTZER and LUCAS: *Journal of experimental medicine*, 1907, ix, p. 208.

<sup>14</sup> STEEL: *Journal of biological chemistry*, 1908, v, p. 111. This paper on the influence of magnesium sulphate on metabolism contains valuable data to which reference will be made later.

## METHODS.

In the present investigation soluble salts of magnesium have been introduced parenterally into different animal species under constant and known conditions of diet, and the subsequent alterations in the content of magnesium (as well as certain other elements) in the excreta have been accurately ascertained. This method, though correct in principle, is not without limitations in its strict quantitative application. Intramuscular or subcutaneous administration of substances which may cause a local disturbance of the tissues involved is not always followed by a speedy and complete absorption of the injected compound. A failure to recognize this has undoubtedly led to errors of interpretation, particularly in studies on calcium salts. Again, the introduction of the foreign substance may lead to a response in the organism whereby the customary withdrawal or utilization of the salt under investigation from its normal sources may be altered and the standard of comparison changed without leaving any indication of the measure of this change. Despite these obvious criticisms and limitations, the parenteral method presents distinct advantages which fully justify its application to the solution of the problems here involved.

**Experimental routine.**—The animals were confined in suitable metabolism cages. The urine was collected by catheterization in many experiments, but not in all. In none of the protocols recorded was there any contamination of urine with feces. Food was given regularly once a day and the cages thoroughly cleaned. Water was allowed *ad libitum*.

With the concentrated diet long in use for dogs in this laboratory, *viz.*, hashed meat, cracker meal, and lard, difficulty was encountered in securing a regular output of definite quantities of feces. The nature of the experiments precluded the addition to the diet of bone meal or bone ash—a procedure recommended by Gies and very advantageous where bulk and firm texture of the feces are desired. After trials with several substances, finely ground agar-agar was found to furnish highly satisfactory results. The material is quite uniform in character, is free from more than traces of nitrogen; and, according to the investigations of Saiki<sup>15</sup> and Mendel,<sup>16</sup> this poly-

<sup>15</sup> SAIKI: *Journal of biological chemistry*, 1906-1907, ii, p. 251.

<sup>16</sup> MENDEL: *Zentralblatt für Stoffwechsel*, 1908, iii, no. 17.

saccharide carbohydrate passes through the alimentary tract without noteworthy alteration by digestive enzymes or micro-organisms. The agar retains moisture well, and if used in appropriate quantity, will give a satisfactory bulk and texture to the faeces. A regular discharge of fairly uniform volume can usually be secured; the stools are readily dried, ground up, and ashed, and are thus well adapted to experiments of the sort here recorded, in which this method was regularly followed in all trials where the faeces were analyzed. It may not be amiss to point out the necessity for a frequent evacuation of the bowel. For it is not difficult to conceive, for example, that a compound rapidly absorbed from under the skin might speedily be secreted into the lumen of the lower gut and excreted along with the faeces derived from a *preliminary period* of feeding which had not yet been discharged. We have taken the *entire* output of faeces of a definite number of days before and after the injections in making our comparisons. The periods were divided in the usual way with lampblack.

**Analytical methods.** — In the urine *calcium* was estimated according to the directions of Neubauer,<sup>17</sup> the precipitate being collected on a Gooch crucible. *Magnesium* was removed from the filtrate by precipitation with ammonia and sodium phosphate in the usual way. *Nitrogen* was determined by the Kjeldahl-Gunning method; *phosphoric acid* by titration with a standard uranium nitrate solution; *chlorides* were estimated by Volhard's method with the modification recommended for dog's urine.<sup>18</sup> The urinary volumes are recorded in approximate figures only.

The faeces were dried over a water bath after admixture with alcohol, and were weighed air-dry. They were ground in a mill to a fine powder, and well-mixed samples of approximately 5 gm. in weight were *thoroughly* ashed in a muffle. The ash was washed into a beaker and boiled five minutes with 100–200 c.c. of 10 per cent hydrochloric acid. After removal of the insoluble residue, the filtrate (while still warm) was made faintly ammoniacal with strong ammonia and then just enough hydrochloric acid added to dissolve the resultant precipitate, whereupon 10–20 c.c. of a 20 per cent solution of sodium acetate were added. Iron is thus quantitatively precipitated (chiefly as phosphate). This precipitate was

<sup>17</sup> HUPPERT: NEUBAUER and VOGEL'S *Analyse des Harns*, 1898, p. 746.

<sup>18</sup> HUPPERT: *Loc. cit.*, p. 708.

examined for calcium, and the filtrate for iron, with negative results. The iron-containing precipitate was filtered off, redissolved in hydrochloric acid, and the iron estimated gravimetrically in the familiar way. Calcium and magnesium were determined in the original iron-free filtrate by the procedure employed in the urine. All analyses were made in duplicate.

**Solutions used.**—No special comment is necessary in respect to the mode of introduction of the magnesium salts further than is indicated in the protocols. The subcutaneous injections were invariably made in one or two spots near the groin and followed usually by slight massage. *All solutions used were sterile* and were introduced with aseptic precautions. When magnesium sulphate was used in this way subcutaneously in dogs and rabbits, *we have never observed abscess formation or necrosis.*<sup>19</sup> When magnesium chloride was employed, however, local inflammation or necrosis was not at all uncommon, despite the precautions indicated above.

With regard to the parenteral dosage of magnesium salts numerous data have been collected in the important papers of Meltzer and Auer.<sup>20</sup> It may be worth while to point out that the figures in their several contributions all refer to the Epsom salt,  $MgSO_4, 7 H_2O$ , although this is not explicitly mentioned in their earlier protocols. Not until we had lost several animals by giving the recommended doses calculated as  $MgSO_4$  in carefully analyzed solutions, were we made aware of this point; and similar experience reported by a colleague leads us to refer to the matter. In the present paper the doses are expressed in terms of  $MgO$ .

#### EXPERIMENTS WITH MAGNESIUM SULPHATE.

**Dogs.**—(1) Female I; weight, 5.5 kilos. Diet, begun Nov. 6, 1906 =

Lean beef . . . . .	100 gm.
Lard . . . . .	15 gm.
Cracker meal . . . . .	65 gm.

<sup>19</sup> Cf. MELTZER and AUER: This journal, 1905, xiv, pp. 374, 378, 380, 387; STEEL: Journal of biological chemistry, 1908, v, p. 85. MELTZER and AUER write: "It remains to be seen whether by sterilization and asepsis such abscesses can be avoided" (p. 387).

<sup>20</sup> Cf. especially MELTZER and AUER: This journal, 1905, xiv, p. 366.

COMPOSITION OF THE URINE.

Period.	Volume, c.c.	CaO, gm.	MgO, gm.
Fore-period (3 days), daily average . . . . .	100	0.007	0.023
Subcutaneous injection of 40 c.c. MgSO <sub>4</sub> solution, representing 0.648 gm. MgO.			
After-period, 1st day . . . . .	190	0.102	0.398
" " 2d day . . . . .	270	0.014	0.057
" " 3d day . . . . .	80	0.008	0.025

No unusual symptoms were observed as the result of the injection. The excess of magnesium on the first after-day over that of the preliminary period was equivalent to about 57 per cent of the amount injected. On the second day an excess of only 5 per cent was eliminated in the urine, the output of the third day being normal again. *Note the marked rise in the calcium output subsequent to the injection.*

(2) Female I; weight, 6.8 kilos. Diet, begun Dec. 2, 1906 =

Lean beef . . . . .	100 gm.	Cracker meal . . . . .	65 gm.
Lard . . . . .	15 "	Salt mixture <sup>21</sup> . . . . .	2 "

COMPOSITION OF THE URINE.

Period.	Volume, c.c.	CaO, gm.	MgO, gm.
Fore-period (5 days), daily average . . . . .	175	0.002	0.061
Subcutaneous injection of 40 c.c. MgSO <sub>4</sub> solution, representing 0.612 gm. MgO.			
After-period (1st day) 12 hrs. . . . .	420	0.040	0.424
" " 12 hrs. . . . .	160	0.008	0.064
" " (2d day) . . . . .	130	0.001	0.028

The animal was not visibly affected by the injection. There was a *marked diuresis* during the first twelve hours after the injection, with an output of about 60 per cent of the magnesium introduced.

<sup>21</sup> This was composed of the following mixture:

Potassium chloride . . . . .	37.0	Magnesium citrate . . . . .	1.0
Sodium chloride . . . . .	12.0	Iron citrate . . . . .	0.25
Calcium chloride . . . . .	4.0	Cane sugar. . . . .	450.0

We occasionally feed this to dogs long confined in cages on a simple diet. (Cf. STEINITZ: *Archiv für die gesammte Physiologie*, 1898, lxxii, p. 81.)

The calcium output also rose during this period. On the second after-day the elimination of both elements in the urine was *below normal*.

(3) Female I; weight, 5 kilos. Diet, begun Nov. 14, 1908=

Lean beef . . . . .	100 gm.
Lard . . . . .	15 "
Cracker meal . . . . .	65 "

COMPOSITION OF THE URINE.

Period.	Volume, c.c.	CaO, gm.	MgO, gm.
Fore-period, (2 days) daily average . . . . .	145	0.007	0.021
Intraperitoneal injection of 40 c.c. MgSO <sub>4</sub> solution, representing 0.612 gm. MgO.			
After-period, 1st day . . . . .	415	0.091	0.453
" " 2d day . . . . .	160	0.015	0.035
" " 3d day . . . . .	150	0.008	0.026

In contrast with the two previous trials with subcutaneous injections of practically the same dose (ca. 0.74 gm. Epsom salt per kgm.), the dog showed signs of loss of muscular control in the legs, twenty minutes after the *intraperitoneal* injection was given. Vomiting occurred, but the vomitus was collected and fed again to the animal. Along with the marked *diuresis* of the first after-day, 70 per cent of the introduced magnesium was eliminated and only about 2 per cent on the second day. *The calcium output was also notably increased* on the first two days. On the third after-day the normal output of both elements was again observed.

(4) Female IV; weight, 12 kilos. Diet, begun Feb. 8, 1907<sup>22</sup> =

Lean beef . . . . .	200 gm.
Lard . . . . .	30 "
Cracker meal . . . . .	120 "

COMPOSITION OF THE URINE.

Period.	Volume, c.c.	CaO, gm.	MgO, gm.
Fore-period (4 days), daily average . . . . .	200	0.030	0.044
Subcutaneous injection of 50 c.c. MgSO <sub>4</sub> solution, representing 0.756 gm. MgO.			
After-period, 1st day . . . . .	475	0.705	0.396
" " 2d day . . . . .	220	0.024	0.072

<sup>22</sup> In this experiment (4) 3 gm. paper pulp were added to the food each day.

(5) Female IV; weight, 13.6 kilos. Same diet as in Experiment 4, begun March 13, 1907.

COMPOSITION OF THE URINE.

Period.	Volume, c.c.	CaO, gm.	MgO, gm.
Fore-period (6 days) . . . . .	320	0.030	0.043
Subcutaneous injection of 50 c.c. MgSO <sub>4</sub> solution, representing 1.00 gm. MgO.			
After-period, 1st day . . . . .	540	0.250	0.540
" " 2d day . . . . .	275	0.033	0.031

(6) Female IV; weight, 13 kilos. Same diet as in Experiments 4 and 5, begun April 5, 1907.

COMPOSITION OF THE URINE.

Period.	Volume, c.c.	CaO, gm.	MgO, gm.
Fore-period (7 days), daily average . . . . .	375	0.030	0.043
Subcutaneous injection of 40 c.c. MgSO <sub>4</sub> solution, representing 0.748 gm. MgO.			
After-period, 1st day . . . . .	400	0.280	0.471
" " 2d day . . . . .	320	0.032	0.070

(7) Female IV, weight 12.8 kilos. Same diet as in Experiments 4, 5, 6, begun April 20, 1907.

COMPOSITION OF THE URINE.

Period.	Volume, c.c.	CaO, gm.	MgO, gm.
Fore-period (4 days), daily average . . . . .	350	0.029	0.036
Intraperitoneal injection of 80 c.c. MgSO <sub>4</sub> solution, representing 1.49 gm. MgO.			
After-period, 1st day . . . . .	600	0.801	1.330
" " 2d day . . . . .	320	0.010	0.072

In these few experiments the total amount of magnesium introduced was larger than in the preceding ones. The amount eliminated in excess, before the output in the urine returned to its normal level, was 50-60 per cent of that introduced, in the subcutaneous trials 4, 5, and 6. The characteristic rise in calcium output is again noted. No anæsthetic effect was manifested, except in Experiment

7. Here a very large dose (ca. 0.67 gm. Epsom Salt per kgm.), introduced *intraperitoneally*, induced vomiting and complete insensibility. Over 80 per cent of the injected magnesium reappeared in the urine within twenty-four hours, accompanied by an increase in calcium output. A similar high urinary output of magnesium was noted in the previous intraperitoneal experiment (3). Anæsthesia is more readily induced by this mode of administration of the salt.

Subcutaneous experiments on two other dogs are further selected to show results entirely comparable with those just presented.

(8) Female VIII; weight, 9.1 kilos. Diet, begun June 1, 1907=

Lean beef . . . . .	200 gm.
Cracker meal . . . . .	75 "
Lard . . . . .	20 "

COMPOSITION OF THE URINE.

Period.	Volume, c.c.	CaO, gm.	MgO, gm.
Fore-period (5 days), daily average . . . . .	230	0.018	0.097
Subcutaneous injection of 30 c.c. MgSO <sub>4</sub> solution, representing 0.828 MgO.			
After-period, 1st day } " " 2d day }	daily average . . . . .	540	0.210
			0.555

(9) Young dog X; weight, 7.4 kilos. Diet, begun Nov. 13, 1907=

Lean beef . . . . .	100 gm.	Cracker meal . . . . .	70 gm.
Lard . . . . .	20 "	Agar-agar . . . . .	2 "

COMPOSITION OF THE URINE.

Period.	Volume, c.c.	N, gm.	P, gm.	CaO, gm.	MgO, gm.
Fore-period (5 days), daily av. . . . .	160	4.04	0.24	0.011	0.038
Subcutaneous injection of 30 c.c. MgSO <sub>4</sub> solution, representing 0.936 gm. MgO.					
After-period, 1st day . . . . .	200	4.17	0.16	0.186	0.424

In these experiments the characteristic increase in the urinary output of both magnesium and calcium after subcutaneous injections of magnesium sulphate is observed. It will be noted in Experiment 9 that *the urinary nitrogen output is not immediately affected* by the magnesium injections. This was likewise observed



in the following experiments, in which both urine and faeces were examined after the injections:

(10) Female IX; weight, 7.2 kilos. Diet, begun Oct. 29, 1907 =

Lean beef . . . . .	100 gm.	Lard . . . . .	20 gm.
Cracker meal . . . . .	70 "	Agar-agar (about) . . . . .	1 "

COMPOSITION OF THE EXCRETA.

Fore-period (6 days), daily average				(4-day period), daily average			
URINE.				FÆCES.			
Volume, c.c.	N, gm.	CaO, gm.	MgO, gm.	Wt., air-dry, gm.	CaO, gm.	MgO, gm.	Fe <sub>2</sub> O <sub>3</sub> , gm.
180	3.20	0.006	0.037	3.1	0.05	0.02	0.03

Subcutaneous injection of 30 c.c. MgSO<sub>4</sub> solution, representing 0.950 g. MgO.

After-period, 1st and 2d days:				Seven-day after-period, daily av.			
230	3.18	0.017	0.423	1.7	0.03	0.01	0.06
210	...	0.007	0.034				

(11) Female XI; weight, 9 kilos. Diet, begun Dec. 5, 1907 =

Lean beef . . . . .	100 gm.	Lard . . . . .	20 gm.
Cracker meal . . . . .	70 "	Agar-agar . . . . .	4 "

COMPOSITION OF THE EXCRETA.

Fore-period (5 days), daily average.

URINE.					FÆCES.				
Volume, c.c.	N, gm.	P, gm.	Clas NaCl, gm.	CaO, gm.	MgO, gm.	Wt., air dry, gm.	CaO, gm.	MgO, gm.	Fe <sub>2</sub> O <sub>3</sub> , gm.
100	4.50	0.181	1.41	0.006	0.036	3.8	0.07	0.023	0.04

Subcutaneous injection of MgSO<sub>4</sub> solution, representing 1.00 gm. MgO.

After-period, 1st day:					Daily av. calculated from output of 5-day after-period.				
130	4.62	0.170	1.21	0.163	0.648	3.2	0.061	0.021	0.5

(12) Young dog XII; weight, 12 kilos. Diet, begun Feb. 2, 1908 =

Lean beef . . . . .	100 gm.	Lard . . . . .	20 gm.
Cracker meal . . . . .	80 "	Agar-agar . . . . .	3 "

## COMPOSITION OF EXCRETA.

Fore-period (11 days) daily average:

Volume, c.c.	URINE.					FÆCES.			
	P, gm.	Cl as gm.	NaCl, gm.	CaO, gm.	MgO, gm.	Wt., air dry, gm.	CaO, gm.	MgO, gm.	Fe <sub>2</sub> O <sub>3</sub> , gm.
80	0.160	2.42	0.020	0.013	7.05	0.16	0.036	0.032	

Subcutaneous injection of 30 c.c. MgSO<sub>4</sub> solution, representing  
0.972 gm. MgO.

After-period, one day:					Av. daily output in 4-day after-period.				
150	0.168	2.01	0.160	0.633	6.5	0.14	0.043	0.022	

(13) Dog XIII; weight, 14 kilos. Diet=

Lean beef . . . . .	150 gm.	Lard . . . . .	20 gm.
Cracker meal . . . . .	80 "	Agar-agar . . . . .	3 "

## COMPOSITION OF THE EXCRETA.

Period.	URINE.		FÆCES.		
	CaO, gm.	MgO, gm.	Wt., air dry, gm.	CaO, gm.	MgO, gm.
Fore-period, daily av.	0.006	0.002	8.1	0.177	0.050

Subcutaneous injection of 30 c.c. MgSO<sub>4</sub> solution, representing  
0.972 gm. MgO.

After-period (14 days).	The entire urine of this period contained 1.00 gm. MgO, accounting for 72 per cent of the quantity injected. The calcium estimation was lost. Cl and P were normal.	Average per day, determined from 14-day after-period.
		8.1    0.12    0.054

The four preceding protocols (10, 11, 12, 13) are of particular interest because they give decisive evidence respecting the relative participation of the intestinal and urinary paths in the elimination of the magnesium after subcutaneous injection of the sulphate. Under these conditions practically *none of the magnesium thus introduced is removed with the fæces*. Indeed, there is in some cases a diminished output per rectum, owing to the constipation induced by the injections (*cf.* 10, 11). This is likewise seen in the case of the calcium of the fæces. The long after-periods (seven to fourteen days) selected exclude the possibility of an unobserved lag in removal through the bowel. Such observations, of course, by no means preclude a secretion of magnesium salts into the intestine; but if this occurred here to any extent, it must have been followed by reabsorption from the gut.

Especially significant is Experiment 13, in which an excess of magnesium equivalent to 72 per cent of the injected magnesium sulphate was recovered in the urine during the long after-period, with practically no alteration in the faecal output.<sup>23</sup> There was a decrease in the intestinal output of calcium after the injections in every case where the faeces were examined for this element also. Whether this is a compensatory result, associated with the increased urinary elimination of calcium, accompanying that of magnesium, cannot be conclusively stated.

As already noted, and further exemplified in Experiments 10 and 11, the *nitrogen output in the urine remained unaffected immediately after the injections*. In comparing this with the observations of Steel,<sup>24</sup> who obtained an increase in nitrogen excretion in some comparable cases, it should be emphasized that in the present experiments local disintegrating effects of the injections did not arise. Steel has expressed the possibility of this factor in explanation of his results. The data recorded above for the other constituents (P, Cl, Fe) do not warrant detailed consideration.

**Cats.** — These animals are unsatisfactory subjects for experiments such as we have outlined. Even with small doses of magnesium sulphate, they almost invariably vomit and refuse to take food with regularity.<sup>25</sup> Below are recorded the only successful experiments out of seven trials.

(14) Cat XIV; weight, 3.4 kilos. Diet, begun Feb. 7, 1908=

Lean beef . . . . .	50 gm.
Cracker meal . . . . .	10 "
Lard . . . . .	5-10 "

COMPOSITION OF THE URINE.

Period.	Volume, c.c.	CaO, gm.	MgO, gm.
Fore-period (20 days), daily average . . . . .	40	0.004	0.009
Subcutaneous injection of 10 c.c. MgSO <sub>4</sub> solution, representing 0.396 gm. MgO.			
After-period, 1st day . . . . .	100	0.008	0.140
“ “ 2d day . . . . .	110	0.040	0.219

<sup>23</sup> For a comparable observation on the faeces alone, after intravenous injection of magnesium sulphate, see STEEL: *Journal of biological chemistry*, 1908, v, p. 111.

<sup>24</sup> STEEL: *Loc. cit.*

<sup>25</sup> Cf. MELTZER and AUER: *This journal*, 1905, xiv, p. 375.

(15) Cat XV; weight, 2.8 kilos. Diet, begun Feb. 8, 1908=

Lean beef . . . . .	40 gm.
Cracker meal . . . . .	10 "
Lard . . . . .	8 "

## COMPOSITION OF THE URINE.

Period.	Volume, c.c.	CaO, gm.	MgO, gm.
Fore-period (9 days), daily average . . . . .	31	0.002	0.007
Subcutaneous injection of 10 c.c. MgSO <sub>4</sub> solution, representing 0.396 gm. MgO.			
After-period, 1st day . . . . .	85	0.007	0.165
" " 2d day . . . . .	35	0.008	0.147

The dose given to these cats was not quite sufficient to produce anæsthesia, although they showed symptoms of weakness. As in the dogs, so in these animals, *the kidneys eliminated an equivalent of a large part of the magnesium introduced* — over 75 per cent in the first two days after the injections. *The urinary calcium was likewise increased*, as in the dog. There was noticeable diuresis.

**Rabbits.**—The following table contains a summary of the protocols of illustrative trials with rabbits. They were fed on carrots, as indicated, and the urine was expressed from the bladder daily.

## RABBITS: COMPOSITION OF THE URINE.

(16) Rabbit XVI; weight, 2.2 kilos. Jan. 11, 1908.

Period.	Food, gm.	Volume, c.c.	P, gm.	CaO, gm.	MgO, gm.
Fore-period (4 days), daily av. . . . .	400	400	0.018	0.070	0.050
Subcutaneous injection of MgSO <sub>4</sub> solution = 0.612 gm. MgO (complete anæsthesia in 15 minutes).					
After-period, 1st day } . . . . .		800	0.021	0.121	0.678
" " 2d day } . . . . .					

(17) Rabbit XVII; weight, 1.6 kilos. Jan. 22, 1908.

Period.	Food, gm.	Volume, c.c.	P, gm.	CaO, gm.	MgO, gm.
Fore-period (6 days), daily av. . . . .	350	300	0.064	0.013	0.057
Subcutaneous injection of MgSO <sub>4</sub> solution = 0.396 gm. MgO (incomplete anæsthesia).					
After-period, 1st day . . . . .		320	0.032	0.048	0.336
" " 2d day . . . . .		300	0.096	0.040	0.093

(18) Rabbit XVIII; weight, 2 kilos. Feb. 1, 1908.

Fore-period, daily average . . . . .	350	300	0.036	0.096	0.054
Subcutaneous injection of MgSO <sub>4</sub> solution = 0.396 gm. MgO (anæsthesia).					
After-period, 1st day . . . . .	...	215	0.014	0.081	0.403
" " 2d day . . . . .	...	300	0.060	0.095	0.075

With regard to the production of definite symptoms by subcutaneous injections of magnesium sulphate in rabbits, it may be remarked that the dosage is by no means uniform, though the range is wider than with cats. For example, in rabbits 17 and 18, respectively, the smaller dose per kgm. animal produced the more profound anæsthesia. Such variations are not uncommon, as Meltzer has pointed out.

The rôle of the kidneys in the elimination of the magnesium is precisely similar to that already noted for the other species studied; *over 80 per cent of the element was found in excess in the urine within forty-eight hours after its introduction.* The calcium and phosphorus outputs showed some irregularity; and there was an absence of the marked diuresis (in so far as the *total* volume of urine was concerned) which was so conspicuous with other animals.

#### EXPERIMENTS WITH MAGNESIUM CHLORIDE.

In order to confirm the observations made with the sulphate, trials were conducted with magnesium chloride likewise. In dogs the subcutaneous injections appear to be painful to the animal.<sup>26</sup> Absorption is slow and abscesses are frequently formed, despite aseptic technic. The results as regards elimination, nevertheless, confirm those recorded above.

(19) Rabbit XX; weight, 1.6 kilos. From Jan. 22, 1908, 350 gm. carrots daily.

#### COMPOSITION OF THE URINE.

Period.	Volume, c.c.	P, gm.	CaO, gm.	MgO, Mg.
Fore-period (14 days), daily average . . . . .	300	0.064	0.013	0.057
Subcutaneous injection of 10 c.c. MgCl <sub>2</sub> solution, representing 0.388 gm. MgO. (Almost complete anæsthesia.)				
After-period, 1st day . . . . .	300	0.023	0.055	0.288
" " 2d day . . . . .	300	0.084	0.032	0.083

<sup>26</sup> Cf. MELTZER and AUER: This journal, 1905, xiv, p. 380.

(20) Rabbit XXI; weight, 2 kilos. Fed 350 gm. carrots daily, from Feb. 1, 1908.

## COMPOSITION OF THE URINE.

Period.	Volume, c.c.	P, gm.	MgO, gm.
Fore-period (4 days), daily average . . .	300	0.036	0.054
Subcutaneous injection of 10 c.c. MgCl <sub>2</sub> solution, representing 0.390 gm. MgO. (Incomplete anaesthesia.)			
After-period, 1st day. . . . .	300	0.020	0.335

In Experiment 19 the equivalent of 65 per cent of the injected magnesium appeared in the urine within forty-eight hours, the calcium output showing a distinct increase over the normal. In Experiment 20, 72 per cent of the magnesium reappeared the first after-day.

(21) Dog XIX; weight, 12 kilos. Diet, begun Feb. 2, 1908 =

Lean beef . . . . .	100 gm.	Lard . . . . .	20 gm.
Cracker meal . . . . .	80 "	Agar-agar . . . . .	3 "

## COMPOSITION OF THE EXCRETA.

Fore-period (17 days), daily av.

URINE.				FÆCES.			
Volume, c.c.	P, gm.	CaO, gm.	MgO, gm.	Wt., air dry, gm.	CaO, gm.	MgO, gm.	Fe <sub>2</sub> O <sub>3</sub> , gm.
82	0.16	0.02	0.018	7.05	0.16	0.039	0.032

Subcutaneous injection of 30 c.c. MgCl<sub>2</sub> solution, representing  
1.166 gm. MgO.

After-period, 1st, 2d, and 3d day.

480	0.18	0.23	0.673	7.0	(Daily average)	0.068	0.023
...	...	...	...				
...	...	...	...				

About 5.1 per cent of the magnesium injected is accounted for in the urine of the first after-day. The small increase noted in the fæces is insignificant, especially in view of the difficulty in obtaining an accurate output in this way. It amounted to about 7 per cent in three days.

GENERAL DISCUSSION OF THE RESULTS.

**The paths of elimination of magnesium.** — The uniformly concordant character of the results obtained in all our experiments with magnesium salts on dogs, cats, and rabbits furnishes conclusive experimental evidence of the predominant importance of the kidneys in the elimination of the excess of magnesium introduced into the blood by parenteral paths. It must not be denied, however, that magnesium can leave the animal body by way of the intestine. For numerous experiments — like those of Renvall, for example — have shown that the *faeces* may contain more magnesium than is introduced directly into the alimentary tract with the diet. Since this is especially noted in cases where the intake of magnesium is very small,<sup>27</sup> it may well be that, aside from unabsorbed food residues, the magnesium of the *faeces* owes its origin to residues of the secretions pouring into the digestive tube.<sup>28</sup> The variations in the intestinal output of magnesium after the injections made in the present investigation were slight and insignificant. This does not exclude the possibility of the development of a vicarious path of elimination by the bowel in conditions of insufficient renal activity.

Where large quantities of magnesium have been found in the *faeces* under ordinary conditions of diet, it seems probable from the present investigation that they represent magnesium which, for the most part at any rate, has never left the alimentary tract and entered the organism in the true sense of the word. A smaller fraction may owe its origin to secretory (or excretory) activities along the intestine. To what extent the influence of other elements simultaneously eliminated may be exerted on the excretion of magnesium cannot as yet be foretold specifically. In another paper it will be shown, however, that introduction of calcium salts into the circulation may be followed by marked increase in the urinary output of magnesium.

**Influence of magnesium salts upon calcium elimination.** — An interesting feature brought to light in our experiments is the *noticeably rise in the urinary output of calcium occurring after the introduction*

<sup>27</sup>Note the data from GOTTSTEIN on p. 3.

<sup>28</sup>Magnesium has been found in small amounts in the contents of isolated intestinal loops ("Ringkoth"). Cf. v. MORACZEWSKI: *Zeitschrift für physiologische Chemie*, 1898, xxv, p. 125.

of magnesium salts. This effect, varying in intensity, was observed in almost every case where quantitative estimates were made. It suggests at once that when magnesium salts are introduced into the circulation, the calcium content of the blood may be increased. In confirmation of the probability of an altered distribution of the calcium, it may further be noted that, as a rule, *the output of calcium with the faeces was diminished after the magnesium injections.* The fall in both calcium and magnesium outputs in the faeces under such conditions may have been associated with the induced constipation, as, for example, in Experiment 10. Feeding experiments by Malcolm,<sup>29</sup> in which the calcium and magnesium intakes were varied by adding solutions of their chlorides to the food water, give some indication of an increased urinary output of one of these elements caused by the administration of the other. There was little effect on the urine, however, and the results recorded are not striking.

In considering the bearing of this interrelation one recalls the recent demonstrations of Meltzer and Auer<sup>30</sup> on the antagonistic action of calcium salts towards the toxic effects of magnesium compounds. Whether the increased output of calcium in the urine (suggesting a preliminary increase of this element in the blood) following the injection of magnesium is to be interpreted as an antitoxic compensatory response of the organism, must for the moment remain an attractive speculation. One gains the impression from our experiments that in those animals (dogs) in which the rise in calcium output subsequent to introduction of magnesium was greatest, the inhibitory dose of the latter is considerably greater per kilo than for rabbits, in which the rise in calcium output was much smaller.

**Other physiological effects. — Diuresis.** — In calling attention to the diuretic effects usually noted in the protocols after injection of magnesium salts, we can conform the comparable observations of Steel.<sup>31</sup>

**Is purgation produced by parenteral administration of magnesium salts?** — Several years ago J. B. MacCallum<sup>32</sup> announced that the saline purgatives, including magnesium sulphate, cause purgation when injected subcutaneously or intravenously. This was quite contrary

<sup>29</sup> MALCOLM: *Journal of physiology*, 1904-1905, xxxii, p. 183.

<sup>30</sup> MELTZER and AUER: *This journal*, 1908, xxi, p. 400.

<sup>31</sup> STEEL: *Journal of biological chemistry*, 1908, v, p. 85.

<sup>32</sup> MACCALLUM, J. B.: *This journal*, 1903-1904, x, p. 101.



to the usually accepted view. Subsequently Meltzer and Auer<sup>33</sup> arrived at the opposite conclusion, demonstrating that purgation never occurs under these conditions. We shall not enter into the details of the controversy which has arisen on this point,<sup>34</sup> further than to call attention to our results. In over fifty experiments purgation (*i. e.*, elimination of increased amounts of faeces of less solid consistency than normal) was observed but once in dogs after parenteral introduction of magnesium salts. Almost invariably the injections are followed by constipation. One typical experiment may be referred to in some detail. A dog (Experiment 10) produced a daily output of 10–15 gm. of unusually soft faeces during a period of about a week prior to the subcutaneous injection of 30 c.c. of magnesium sulphate solution containing 0.096 gm.  $MgSO_4$  per kilo. On the first two days following, no output of faeces occurred; and on the third day they were quite dry and firm (and contained less calcium and magnesium than normally). In rabbits the injection of magnesium sulphate was usually followed by constipation, never by purgation. In respect to magnesium sulphate the experience in this laboratory fully corroborates the contentions of Auer. We cannot, however, make an equally positive statement regarding magnesium chloride. Auer says: "The subcutaneous and intravenous injection of magnesium sulphate and chloride . . . does not produce purgation in rabbits."<sup>35</sup> We have failed to discover any published experiment by Meltzer, Auer, or Bancroft in which the purgative action of the *chloride* has been adequately studied. In our own trials on rabbits three out of five injections were followed within two hours by a noticeable output of moister faeces than were observed in control animals. It is not intended to imply by this statement that magnesium chloride, introduced parenterally into rabbits, necessarily or even usually provokes purgation. The problem is apparently not definitely settled by our experiments in this case, as it was in the sulphate trials.<sup>36</sup>

<sup>33</sup> MELTZER and AUER: This journal, 1905, xiv, p. 366.

<sup>34</sup> Cf. AUER: This journal, 1906, xvii, p. 15; BANCROFT: Journal of biological chemistry, 1907, iii, p. 191; AUER: *Ibid.*, 1908, iv, p. 197; STELL: *Ibid.*, 1908, v, p. 120.

<sup>35</sup> AUER: This journal, 1906, xvii, p. 25.

<sup>36</sup> In this connection it may be remarked that the quantitative study of the output of faeces by rabbits (and occasionally by dogs) is liable to decided inaccuracy unless special precautions are taken to prevent the animals confined in cages from eating

## CONCLUSIONS.

The experimental observations recorded in this paper are believed to justify the following conclusions:

*When soluble magnesium compounds are introduced parenterally into animals, the greater portion of the excess injected leaves the body by way of the kidneys, within less than forty-eight hours.* The importance of the kidney in the elimination of magnesium is thus emphasized. The evidence was obtained from experiments on dogs, cats, and rabbits, with magnesium sulphate and chloride, used subcutaneously and intraperitoneally.

*The intestinal path is of minor, if any, significance for magnesium introduced under these conditions.* The magnesium output in the faeces was not noticeably increased by the injections.

*A considerable quantity of magnesium may be retained in the body for periods exceeding two weeks.* This was indicated in the comparisons made between the total output and the parenteral intake.

*The increased excretion of magnesium by the kidneys is accompanied by a marked rise in the urinary output of calcium.* The calcium output in the faeces is decreased, if anything, at the same time. A possible significance of these facts is discussed.

*The output of nitrogen and chlorides is not appreciably affected by the injections;* at least, not within the brief periods of observation. The intestinal output of iron appears to be somewhat disturbed.

*The parenteral introduction of magnesium sulphate in dogs and rabbits is never followed by purgation.* The evidence for magnesium chloride is not conclusive. Diuresis followed the use of both salts. Other less significant observations, such as the frequency of abscess formation, etc., are commented upon in the paper.

their faeces. This is true at times even where food is exhibited. We have seen several rabbits which ate their faeces in place of fresh carrots. Such coprophagists require a mask. Whether the experiments of other workers have yielded misleading results owing to a failure to appreciate this danger, cannot be stated. All protocols in which absence of faeces is reported during a considerable interval of time in normal rabbits are open to this suspicion.

## THE PATHS OF EXCRETION FOR INORGANIC COMPOUNDS. — V. THE EXCRETION OF CALCIUM.

BY LAFAYETTE B. MENDEL AND STANLEY R. BENEDICT.

[From the Sheffield Laboratory of Physiological Chemistry, Yale University.]

THE observation of an increased output of calcium in the urine after parenteral introduction of magnesium salts, which has been reported in the preceding paper, was the immediate occasion for a few experiments on the excretory fate of calcium salts. It is generally conceded that only the smaller portion of absorbed calcium is eliminated through the kidneys, the intestine taking the pre-eminent share in the excretory process.<sup>1</sup> The arguments which have been adduced in favor of a study of the paths of elimination of magnesium under conditions where the uncertain factors of alimentary absorption are avoided apply with equal cogency in the case of calcium. In appreciation of this there appear in the physiological literature a number of records of the fate of calcium salts after subcutaneous and intraperitoneal injection. Commenting upon them, Magnus Levy says: "The intestine is the actual seat of the excretion of lime, the kidneys being concerned in only a secondary way."<sup>2</sup>

Certain conditions are counted among the agencies which influence the distribution of calcium in the excreta. They concern in part the solubility of the salts of the element and hence its capacity for transportation in the organism. The paths of elimination of ingested calcium are said to depend upon the nature of the food,

<sup>1</sup> Cf. for example, ALBU and NEUBERG: *Physiologie und Pathologie des Mineralstoffwechsels*, 1906, p. 116. This book summarizes much of the literature on the subject.

<sup>2</sup> MAGNUS LEVY: *VON NOORDEN'S Handbuch der Pathologie des Stoffwechsels*, 1906, i, p. 41.

c. g., the concomitant presence of phosphoric acid.<sup>3</sup> The reaction of the body fluids may likewise be of significance.

The data collected by Renvall<sup>4</sup> gives some idea of the variations which have been recorded (Table I).

TABLE I.  
TABLE SHOWING PERCENTAGE DISTRIBUTION OF CALCIUM OUTPUT.

Subject.	Urine.	Fæces.	Investigator.
Man . . . . .	41.8	58.2	Bertram
Man . . . . .	60.9	39.1	Renvall
Man . . . . .	64.3	35.7	Renvall
Man . . . . .	29.1	70.9	Renvall
Man . . . . .	36.1	63.9	Renvall
Man . . . . .	25.4	74.6	Renvall
Dog . . . . .	20.6	79.4	Perl
Dog . . . . .	3.0	97.0	Tereg and Arnold
Dog . . . . .	18.0	82.0	Tereg and Arnold
Dog . . . . .	27.2	72.8	Heiss
Goat . . . . .	4.8	95.2	Bertram
Sheep . . . . .	4.1	95.9	Henneberg
Infant (natural food) . . . . .	31.9	68.1	Blauberg
Infant (cow's milk) . . . . .	2.2	97.8	Blauberg
Infant (cereal preparation) . . . . .	9.5	90.5	Blauberg
Infant (cow's milk) . . . . .	1.4	98.6	Blauberg
Horse . . . . .	40.0	60.0	Tangl <sup>1</sup>

<sup>1</sup> These figures were calculated from data by TANGL: Archiv für die gesammte Physiologie, 1902, lxxxix, p. 227.

The exceptionally high figures occasionally obtained on the urine by Renvall in his own person are associated with a small intake of

<sup>3</sup> Cf. OERI: Zeitschrift für klinische Medizin, 1909, lxvii, p. 228.

<sup>4</sup> RENVALL: Skandinavisches Archiv für Physiologie, 1904, xvi, p. 114.

calcium. Ordinarily an increase in the intake of calcium is followed by only a slight increase, at most, in the urine. Augmented elimination through the kidneys may be observed when a carbohydrate-free diet is taken.<sup>5</sup> The contribution to the output from secretions discharging into the intestine is conclusively demonstrated in numerous experiments in which the quantity of faecal calcium alone far exceeds the intake.

The experimental evidence regarding the relative participation of the excretory channels in the removal of injected calcium is rather meagre. In so far as the subcutaneous administration is concerned our experience has demonstrated that little reliance is to be placed on the subsequent elimination data, because the injections may be attended with serious local disturbances and the absorption factor is entirely uncertain. Long ago Tereg and Arnold<sup>6</sup> compared the output of calcium in the urine of dogs which received the same dosage of acid calcium phosphate orally and subcutaneously. The subcutaneous experiments could not be satisfactorily completed because of the local conditions induced in the animals. In so far as they go, however, they indicate a small increase in the urinary output after introduction of 5 gm. of the phosphate as follows:

AVERAGE DAILY OUTPUT OF CAO IN URINE.

	I.	II.
Normal diet. . . . .	0.028	0.034
Normal diet + 5 gm. phosphate per os . . . . .	0.064	....
Normal diet + 5 gm. phosphate subcut. . . . .	0.060—0.108	0.063

Absorption from the subcutaneous injection site must have been very slow, and the output of calcium was always greater on days subsequent to the introduction of the salt.

Rüdel<sup>7</sup> criticised the foregoing experiments on the ground that the salt used—the acid phosphate—was unsuitable, being liable to precipitation in the tissues. He himself conducted four experiments (two on rabbits and two on dogs) in which calcium acetate was given subcutaneously in doses equivalent to 0.2–1.2 gm. CaO.

<sup>5</sup> Cf. THAYER and HAZEN: *Journal of experimental medicine*, 1907, ix, p. 7.

<sup>6</sup> TEREK and ARNOLD: *Archiv für die gesammte Physiologie*, 1883, xxxii, p. 122.

<sup>7</sup> RÜDEL: *Archiv für experimentelle Pathologie und Pharmakologie*, 1894, xxxiii, p. 87.

The increase in urinary calcium represented from 12 to 34 per cent of the quantity injected.

In supplementing these findings Rey<sup>8</sup> showed an increase in the calcium content of the large intestine after subcutaneous and intravenous injections of calcium salts, thus locating an important place of elimination.

Goitein<sup>9</sup> gave subcutaneous injections to a rabbit fed on maize (poor in calcium) and obtained the following balance in a four-day experiment:

Ca intake in food . . .	0.033 gm.	Ca output urine . . .	0.238 gm.
Ca intake injected . . .	1.645 "	Ca output faeces . . .	1.145 "
	<u>1.678 gm.</u>		<u>1.383 gm.</u>

#### METHODS EMPLOYED.

Repeated trials of subcutaneous injections of calcium chloride in dogs were attended with the development of necrotic areas, in some cases proving fatal where the dose was fairly large (5 gm.  $\text{CaCl}_2$  in 50 c.c. water). Absorption in such cases must be very imperfect, as has already been intimated. Intraperitoneal injections of 0.2 to 0.4 gm.  $\text{CaO}$  (as  $\text{CaCl}_2$ ) in rabbits were likewise most unsatisfactory. It was therefore determined to introduce the calcium salt directly into the blood stream. The excreta were examined for both calcium and magnesium by the methods outlined in the previous paper,<sup>1</sup> and the conduct of the experiments followed the general plan outlined for the studies on magnesium. In dogs the injections were made into the jugular vein during light ether anesthesia; in rabbits, into the marginal ear vein without the use of ether. The operations were conducted aseptically, and the skin wounds rapidly healed. The intravenous introduction of the calcium salt was invariably attended with marked respiratory disturbances, the respiration ceasing temporarily in some instances.

**Rabbits. — Control experiment with sodium chloride.** — Inasmuch as all of the intravenous injections were carried out with the calcium salt dissolved in 0.7 per cent  $\text{NaCl}$  solution, a trial with this fluid alone was made for comparison, as follows:

<sup>8</sup> REY: *Ibid.*, 1895, xxxv, p. 298.

<sup>9</sup> GOITEIN: *Archiv für die gesammte Physiologie*, 1906, cxv, p. 118.

<sup>10</sup> This journal, p. 3.

(1) Rabbit XII; weight, 2 kilos. From May 6, 1908, 300 gm. carrots were fed daily.

COMPOSITION OF THE URINE.

Period.	Volume, c.c.	CaO, gm.	MgO, gm.
Fore-period (2 days), daily average . .	360	0.102	0.0684
Intravenous injection of 200 c.c. 0.7 per cent sodium chloride solution.			
After-period, 1st day . . . . .	450	0.086	0.0576

This experiment demonstrates the failure of the sodium chloride solution *per se* to increase the output of the alkali earths, there being, if anything, a slight decrease on the day after the injection.

**Experiments with Calcium Chloride. Fasting Animals.** — (2) Rabbit VIII; weight, 1.4 kilos. No food.

COMPOSITION OF THE URINE.

Period.	Volume, c.c.	CaO, gm.	MgO, gm.
Fore-period (3 days), daily average . .	40	0.004	0.009
Intravenous injection of 200 c.c. 0.7 per cent NaCl solution containing 0.2 gm. CaO as CaCl <sub>2</sub> .			
After-period, 1st day . . . . .	120	0.115	0.025
"    "    2d and 3d days . . . . .	60	0.015	0.007

This animal exhibited slight loss of muscular control about two hours after the injection; but recovery rapidly followed. An excess of calcium equivalent to 59 per cent of that injected was eliminated in the urine on the first after-day and 10 per cent during the subsequent two days. It will be noted that *the magnesium output in the urine is likewise increased*. These results are duplicated in the following experiment:

(3) Rabbit IX; weight, 2.1 kilos. No food.

COMPOSITION OF THE URINE.

Period.	Volume, c.c.	CaO, gm.	MgO, gm.
Fore-period (5 days), daily average . .	35	0.005	0.008
Intravenous injection of 150 c.c. 0.7 per cent NaCl solution containing 0.2 gm. CaO as CaCl <sub>2</sub> .			
After-period, 2d day . . . . .	160	0.073	0.018

**Animals fed.** — In the following two experiments the rabbits received 300 gm. carrots daily.

(4) Rabbit X; weight, 2.4 kilos.

COMPOSITION OF THE URINE.

Period.	Volume, c.c.	CaO, gm.	MgO, gm.
Fore-period (2 days), daily average . .	350	0.121	0.072
Intravenous injection of 200 c.c. 0.7 per cent NaCl solution containing 0.21 gm. CaO as CaCl <sub>2</sub> .			
After-period, 1st day . . . . .	600	0.263	0.118

(5) Rabbit XI; weight 2.4 kilos.

COMPOSITION OF THE URINE.

Period.	Volume, c.c.	CaO, gm.	MgO, gm.
Fore-period (4 days), daily average . .	350	0.112	0.076
Intravenous injection of 200 c.c. 0.7 per cent NaCl solution containing 0.21 gm. CaO as CaCl.			
After-period (7 days) per day . . . . .	340	0.129	0.078

In these two experiments (4) and (5) the increased output of calcium in the urine likewise amounted to over 50 per cent of the quantity injected, with a simultaneous increase in magnesium elimination.

**Dogs.** — (6) Dog I; weight, 11 kilos. April 3, 1908. No food.

COMPOSITION OF THE URINE.

Period.	Volume, c.c.	CaO, gm.	MgO, gm.
Fore-period (3 days), daily average . .	125	0.008	0.009
Intravenous injection of 300 c.c. 0.7 per cent NaCl solution containing 0.4 gm. CaO as CaCl <sub>2</sub> .			
After-period, first 3 hrs. . . . .	250	0.060	0.041
" " next 21 hrs. . . . .	500	0.036	0.028
" " first day . . . . .	750	0.096	0.069
" " 2d and 3d day (daily av.) . .	125	0.008	0.026



This record shows an excess of 15 per cent of calcium excreted by the kidneys within three hours, and 20 per cent within the first day. A marked diuresis followed the injection, and *the output of magnesium was increased notably.*

(7) Dog III; weight, 14 kilos. Diet begun May 10, 1908=

Lean beef . . . . .	150 gm.	Lard . . . . .	20 gm.
Cracker meal . . . . .	80 gm.	Agar-agar . . . . .	1½ gm.

COMPOSITION OF THE URINE.

Period.	Volume, c.c.	CaO, gm.	MgO, gm.
Fore-period (2 days), daily average . . .	100	0.007	0.017
Intravenous injection of 200 c.c. 0.7 per cent NaCl solution containing 0.4 gm. CaO as CaCl <sub>2</sub> .			
After-period, first day . . . . .	400	0.075	0.072

(8) Dog II; weight, 14 kilos. Diet, begun April 26, 1908, same as in Experiment (7).

COMPOSITION OF THE EXCRETA.

Period.	URINE.			FÆCES.		
	Volume, c.c.	CaO, gm.	MgO, gm.	Wt. air dry, gm.	CaO, gm.	MgO, gm.
Fore-period (9 days) daily av. . . . .	100	0.007	0.017	7.3	0.10	0.047
Intravenous injection of 300 c.c. 0.7 per cent NaCl solution containing 0.4 gm. CaO as CaCl <sub>2</sub> .						
After-period (1st day) . . . . .	1200	0.074	0.086	..	...	.....
" " (6 days) daily average	100	0.008	0.014	6.6	0.11	0.047

Here the marked diuresis is again noted, and a small rise in calcium output on the first day following the injection. The magnesium in the urine is increased as usual. *No noteworthy increase in the loss of calcium or magnesium with the fæces was observed.* This unexpected result has been verified in two further experiments on dogs in which the fæces alone were analyzed before and after the injections. The diet in each case consisted of:

Lean beef (about) . . . . .	150 gm.	Lard (about) . . . . .	20 gm.
Cracker meal " . . . . .	70 "	Agar-agar " . . . . .	2 "

The intravenous injections consisted of 250 c.c. 0.7 per cent NaCl solution containing 0.4 gm. CaO as CaCl<sub>2</sub>.

(9) Dog A; weight, 12 kilos. May 31, 1908.

COMPOSITION OF THE FÆCES.

	Fore-period (6 days). gm.	After-period (6 days). gm.
Weight, air dry . . . . .	60.0	49.0
CaO . . . . .	0.908	0.840
MgO . . . . .	0.462	0.362

(10) Dog B.; weight, 9 kilos. June 6, 1908.

Weight, air dry . . . . .	36.0	34.0
CaO . . . . .	0.840	0.900
MgO . . . . .	0.279	0.253

DISCUSSION OF THE RESULTS.

**The paths of elimination of calcium.** — There can be no doubt, in view of the experiments reported, that the kidneys may participate in the elimination of calcium when it is actually introduced into the circulation in dogs and rabbits. In the case of the latter animals an equivalent of more than half of the calcium injected was recovered in the urine within two days. No account was taken of the output by the intestine. In the dogs, however, Experiments 8, 9, and 10 failed to show any increase in the loss of calcium with the fæces after intravenous injection of the chloride. That the volume of fluid injected and the sodium chloride used are not responsible for the urinary output of calcium is shown by Experiment 1. Boekellmann and Staal<sup>11</sup> state that diuresis has no effect on the elimination of calcium. No essential differences are noted in the relative extent of elimination by the kidneys according as the animals were fed or starved. (*Cf.* Experiments 2 and 4, rabbits; 6 and 8, dogs.) These comparisons are of some interest in view of the statements regarding the influence of diet on the paths of elimination.<sup>12</sup> In all of the cases where the balance of calcium was determined, a marked

<sup>11</sup> BOEKELLMANN and STAAL: *Archiv für experimentelle Pathologie und Pharmakologie*, 1907, lvi, p. 260.

<sup>12</sup> *Cf.* BOEKELLMANN and STAAL: *Archiv für experimentelle Pathologie und Pharmakologie*, 1907, lvi, p. 260; OERI: *Zeitschrift für klinische Medizin*, 1909, lxxvii, pp. 288, 307.

retention was noted. The fact that the higher excretion by the kidney soon subsides speaks against a slow or gradual subsequent elimination in these cases. We hope at some time to ascertain more definitely the fate of the unrecovered excess of the alkali earth in such experiments.

**The influence of calcium salts upon magnesium excretion.**—The interrelationship of calcium and magnesium excretion has been demonstrated in these experiments as well as those reported in the preceding paper. The increased output of magnesium in the urine after intravenous injections of calcium chloride is not attributable to the solvent used or the diuresis (*cf.* Experiment 1). It is, perhaps, the most noteworthy feature of this investigation, and brings further emphasis to the suggestion previously made, that the physiological antagonism of the two elements may furnish the ultimate explanation for the relations which we have established by our analyses. Further theoretical considerations have been discussed in the paper on magnesium (p. 1).

**Other physiological effects.**—**Diuresis.**—The injections of calcium chloride in sodium chloride solution were uniformly followed by diuresis. J. B. Macallum<sup>13</sup> has stated that the quantity of urine secreted may for a time be markedly diminished and in some cases almost entirely inhibited by the introduction of calcium chloride into the circulation. According to him it diminishes not only the normal flow, but also that which is caused by the administration of saline diuretics, such as "physiological" salt solution. There is no evidence of such suppression with the doses and concentrations of calcium salt used in our trials. The protocol of Experiment 6 indicates an output of 250 c.c. of urine within three hours after the injection of 0.4 gm. CaO as CaCl<sub>2</sub>. This corresponds with the recent contention of Porges and Pribram<sup>14</sup> that the suppression of urine can be accomplished only by large doses of calcium chloride, inducing simultaneous fall in blood pressure. When the salt is introduced in concentrations which leave the latter unaffected, calcium chloride exhibits a diuretic action comparable to that of sodium chloride.

**Toxicity and other symptoms.**—In speaking of the soluble calcium salts injected directly into the blood vessels, Cushny writes:

<sup>13</sup> MACALLUM: University of California publications, *Physiology*, 1904, ii, p. 31.

<sup>14</sup> PORGES and PRIBRAM: *Archiv für experimentelle Pathologie und Pharmakologie*, 1908, lix, p. 30.

"They depress the central nervous system, causing narcosis and sleep, during which some authors state that the reflexes remain unaffected, while others found them much depressed."<sup>15</sup> Meltzer and Auer make the following statement: "We could never produce by subcutaneous or intravenous injections of calcium salts an anæsthetic or paralytic effect in any way similar to that produced by magnesium salts. Even when large fatal doses were employed by intravenous injections, the animal was wide awake, and the lid reflex, etc., was preserved until shortly before death."<sup>17</sup> What character of symptoms was observed is not pointed out. It cannot have been the intent of these investigators to give the impression that evidence of "depression" never occurs; for we have noted such in rabbits that received doses of about 0.8 gm.  $\text{CaCl}_2$  intraperitoneally. An illustrative protocol of perhaps the most striking effects may be recorded here.

A rabbit weighing 2 kgm. received an intraperitoneal injection of 35 c.c. calcium chloride solution containing about 0.8 gm.  $\text{CaCl}_2$  (0.4 gm.  $\text{CaO}$ ), at 10.45. At 1.15 the animal began to show slight symptoms of loss of muscular control. At 2.00 the rabbit lay sprawled out and made no voluntary movements. Respirations were deep and slow. At 2.30 the reflexes were "depressed" slightly, but the animal appeared to retain consciousness. At 4.00 the animal showed slight improvement and could move slightly when irritated. Respiration was improved. At 5.30 death. The urine contained sugar.<sup>17</sup>

Another rabbit of 1.7 kgm. died after receiving an intravenous injection of 140 c.c. 0.7 per cent  $\text{NaCl}$  solution containing less than 0.6 gm.  $\text{CaCl}_2$ . In Experiment 2 slight loss of muscular control also occurred about two hours after the injection.

#### CONCLUSIONS.

The experimental observations recorded in this paper are believed to justify the following conclusions:

*When calcium chloride is introduced intravenously into animals, the excess may be eliminated in part by the kidneys.* From the

<sup>15</sup> CUSHNY: Pharmacology, ed. 1899, p. 548.

<sup>16</sup> MELTZER and AUER: This journal, 1908, xxi, p. 403.

<sup>17</sup> Cf. UNDERHILL and CLOSSON: This journal, 1906, xv, p. 321; UNDERHILL and KLEINER: Journal of biological chemistry, 1908, iv, p. 395.

few experiments made it appears that a larger proportion is thus excreted in rabbits (50–60 per cent) than is the case in dogs (15–20 per cent). *Simultaneous increased excretion through the bowel does not necessarily occur.*

*A considerable quantity of the excess of calcium introduced may be retained for some time in the body.*

*The increased excretion of calcium is accompanied by a rise in the urinary output of magnesium.* The possible significance of this interrelationship is discussed.

The injections of calcium chloride (with NaCl solution) were followed by diuresis.

## THE INFLUENCE OF THE ISOMERS OF SALICYLIC ACID ON METABOLISM.

By ELBERT W. ROCKWOOD.

[From the Chemical Laboratory of the University of Iowa.]

WHILE there is still uncertainty as to the production of uric acid in the animal body, it is generally believed that in mammals it is largely formed in the liver through the action of ferments upon the nucleins or their decomposition products. Although synthesis may account for a part of that eliminated, convincing proof of this is wanting. In addition to the formative — that is, the nuclein cleaving and oxidizing — ferments, there is, as shown by Burian, Schnittenhelm, and others, a uricolytic ferment which destroys the uric acid previously produced, so that the amount appearing in the urine represents only the balance between that formed and destroyed. The results reported here are from a series of experiments designed to throw more light upon the action of these ferments and the conditions which may influence them in the human body.

In order to simplify the problem exogenous uric acid was eliminated by limiting the subjects to a purin-free diet. This consisted of wheat foods, milk, eggs, butter, and cheese, with no potatoes, or very little, and the kinds and amounts were practically the same each day of the experiment. The selection of the kinds and amounts were otherwise left to the choice of the subject, the only specification being that the diet should be one which could be eaten with satisfaction throughout the test. In no case was there any disturbance which could be subjectively noted by the experimenters.

If the source of the uric acid is largely the nucleins, its production should be accompanied by the formation of phosphoric acid from the oxidation of the phosphorus of the nucleins, and the amounts of the two eliminated through considerable periods of time should correspond. Increased destruction of the nucleins can be expected to increase both products without changing their rela-

tive amounts; greater destruction of the uric acid after its formation would lessen the ratio  $\frac{\text{uric acid.}}{\text{phosphoric acid}}$ . As a measure of the general metabolism, nitrogen was determined and usually creatinin; ammonia was determined in some instances.

The drugs of which the effects were tested were ortho-oxy benzoic acid,  $\begin{array}{c} \text{COOH} \\ | \\ \diagup \quad \diagdown \\ | \quad | \\ \diagdown \quad \diagup \\ \text{OH} \end{array}$ , (salicylic acid), meta-oxy benzoic acid,  $\begin{array}{c} \text{COOH} \\ | \\ \diagup \quad \diagdown \\ | \quad | \\ \diagdown \quad \diagup \\ \text{OH} \end{array}$ , and para oxy-benzoic acid,  $\begin{array}{c} \text{COOH} \\ | \\ \diagup \quad \diagdown \\ | \quad | \\ \diagdown \quad \diagup \\ \text{OH} \end{array}$ .

The quantitative methods used were Kjeldahl's for nitrogen, uranium acetate for phosphoric anhydrid, and Folin's for uric acid, creatinin, and ammonia.

The ortho-oxy benzoic acid has been for years regarded as capable of aiding the elimination of uric acid from the body and definitely proved to do so by Jackson and Blackfan,<sup>1</sup> Rockwood and Van Epps,<sup>2</sup> among others. Its salts and aspirin, the acetic acid ester, act in the same manner. For comparison with the effects of its isomers its action is shown in Table I.

The subject, A, was a physician thirty-one years of age, weighing 120 pounds. He was accustomed to such dieting experiences. The eliminated uric acid is increased by the aspirin and to a certain extent varies with it. The practical constancy of the total nitrogen and creatinin shows no indication of disturbance of general metabolism. The fact that the  $\text{P}_2\text{O}_5$  does not vary with the uric acid may be taken to indicate that there is not an increased formation from the nucleins, but rather a decreased destruction of the uric acid; that is, the uric acid ferment is to some extent inhibited by the ortho compound. It is to be noted that with the discontinuance of the drug there was a sudden drop in the eliminated uric acid, which but slowly rose to the normal endogenous level. A similar result was obtained in another case by Rockwood and Van Epps.<sup>3</sup> There was no corresponding variation in the other constituents of the urine so far as they were determined.

As compared with the action of the ortho compound Table II

<sup>1</sup> JACKSON and BLACKFAN: Albany medical annals, 1907, xviii, p. 24.

<sup>2</sup> ROCKWOOD and VAN EPPS: This journal, 1907, xix, p. 97.

<sup>3</sup> *Loc. cit.*, p. 103.

TABLE I.  
SUBJECT A.

Date.	Conditions.	Volume.	Crea- tinin.	Uric Acid.	Total N.	P <sub>2</sub> O <sub>5</sub>
		c.c.	gm.	gm.	gm.	gm.
May 23	Endogenous . . . . .	....	...	0.388	....	...
24	Endogenous . . . . .	....	...	0.289	....	...
	Average, endogenous . . . . .	....	...	0.328	....	...
25	1.7 gm. aspirin . . . . .	....	...	0.328	....	...
26	3.7 gm. aspirin . . . . .	980	1.04	0.601	10.12	2.42
27	2.0 gm. aspirin . . . . .	950	1.07	0.481	10.12	2.33
28	2.0 gm. aspirin . . . . .	980	...	0.446	10.41	2.48
29	2.3 gm. aspirin . . . . .	1085	1.14	0.413	12.03	2.50
30	2.6 gm. aspirin . . . . .	1580	1.23	0.465	12.92	2.84
31	2.6 gm. aspirin . . . . .	780	1.01	0.414	8.62	2.30
June 1	3.3 gm. aspirin . . . . .	730	1.17	0.341	10.89	2.28
2	4.0 gm. aspirin . . . . .	1480	1.09	0.411	11.75	2.10
3	1.3 gm. aspirin . . . . .	800	1.09	0.360	10.89	2.40
4	2.6 gm. aspirin . . . . .	950	1.07	0.366	10.96	2.26
5	3.7 gm. aspirin . . . . .	1116	1.03	0.458	11.67	2.55
	Average, aspirin period . . . . .	....	1.07	0.424	10.03	2.41
6	Endogenous . . . . .	1025	1.06	0.096	10.57	2.60
7	Endogenous . . . . .	1130	1.13	0.278	9.24	2.74
8	Endogenous . . . . .	1030	...	0.268	....	...
	Average, endogenous . . . . .	....	1.10	0.214	9.91	2.67

shows that meta-oxy benzoic acid did not increase the elimination of uric acid, — if there was any change, there was a slight decrease. Large amounts of the drug have a diuretic effect, shown also in Table III, and this greater volume of excreted fluid will readily ex-



plain the increased nitrogen; otherwise the drug had no visible effect.

Table III gives results of ingestion of the para-oxy benzoic acid. The subject was a medical student twenty-nine years of age

TABLE II.  
SUBJECT A.

Date.	Conditions.	Volume.	Crea- tinin.	Uric acid.	Total N.	P <sub>2</sub> O <sub>5</sub>
		c. c.	gm.	gm.	gm.	gm.
March 21	Endogenous . . . . .	585	1.19	0.317	8.93	1.00
22	Endogenous . . . . .	1180	1.17	0.226	....	1.16
23	Endogenous . . . . .	880	1.18	0.254	....	1.02
24	Endogenous . . . . .	650	1.05	0.302	....	1.07
24	Average, endogenous . . . . .	....	1.15	0.275	....	1.06
25	2 gm. meta-oxy benzoic acid . .	540	1.06	0.257	9.85	1.15
26	4 gm. meta-oxy benzoic acid . .	1300	1.22	0.185	13.36	1.00
27	4 gm. meta-oxy benzoic acid . .	760	1.32	0.308	11.35	0.98
28	4 gm. meta-oxy benzoic acid . .	1875	1.05	0.295	12.60	1.11
29	8 gm. meta-oxy benzoic acid . .	2350	1.09	0.194	20.53	0.87
	Average, meta-oxy benzoic acid	....	1.15	0.248	13.54	1.02
30	Endogenous . . . . .	600	1.05	0.285	7.10	0.81
31	Endogenous . . . . .	....	1.03	0.248	....	0.96
April 1	Endogenous . . . . .	1100	0.94	0.292	8.26	0.86
2	Endogenous . . . . .	1000	1.19	0.281	11.62	1.13
	Average, endogenous . . . . .	....	1.05	0.277	8.99	0.94

and weighing at the beginning of the test 235 pounds. Nine days afterwards his weight had fallen to 227 pounds, probably largely due to an attack of gastritis, and then rose to 231 pounds at the close of the period. That he was susceptible to the action of the

TABLE III.

SUBJECT C.

Date	Conditions.	Vol- ume.	Crea- tinin.	Uric acid.	N in NH <sub>3</sub>	Total N.	P <sub>2</sub> O <sub>5</sub>
		c c.	gm.	gm.	gm.	gm.	gm.
Feb. 13	Endogenous . . . . .	1300	1.62	0.361	0.523	11.07	1.90
14	Endogenous . . . . .	1100	2.08	0.424	0.405	12.90	2.35
15	Endogenous . . . . .	1025	2.20	0.434	0.590	11.32	2.13
17	Endogenous . . . . .	1030	1.78	0.436	0.722	10.09	2.00
18	Endogenous . . . . .	1250	1.56	0.413	0.770	9.38	1.89
	Average, endogenous . . .	...	1.85	0.415	0.602	10.95	2.05
19	2.7 gm. para-oxy benzoic acid	950	1.97	0.446	0.715	9.59	1.58
20 <sup>1</sup>	Endogenous . . . . .	1070	1.68	0.506	0.826	10.70	2.80
23	Endogenous . . . . .	1175	1.83	0.478	0.494	11.26	2.44
24	Endogenous . . . . .	850	1.84	0.417	0.575	....	1.43
	Average endogenous, 3 days	...	1.78	0.467	0.773	10.98	2.22
25	1 gm. meta-oxy benzoic acid .	1075	1.90	0.310	0.461	9.70	1.75
26	3 gm. meta-oxy benzoic acid .	1150	1.58	0.380	0.829	....	1.89
27	9 gm. meta-oxy benzoic acid .	2200	1.85	0.396	0.829	11.96	2.29
	Average, meta-oxy benzoic acid	...	1.78	0.362	0.706	10.83	1.98
28	Endogenous . . . . .	1180	1.67	0.376	0.495	10.30	2.18
29	Endogenous . . . . .	700	...	0.357	....	....	...
March 1	4 gm. sodium salicylate . . .	1250	...	0.588	....	....	...

<sup>1</sup> Feb. 21 and 22 mild attack of gastritis. Urine not tested.

ortho compound is shown by the decided rise in uric acid with the final administration of sodium salicylate.

The meta compound shows a decrease rather than an increase in the uric acid. The para compound shows no decided increase within twenty-four hours after administration of the drug. On the second day the amount of uric acid was above the average, but the proof that this is the result of the drug is inconclusive and, taken in connection with corresponding results from other subjects and the onset of the attack of gastritis, the natural conclusion is that in this dose para-oxy benzoic acid does not increase the uric acid output. The

TABLE IV.

SUBJECT B.

Date.	Conditions.	Vol- ume.	Uric acid.	Total N.	P <sub>2</sub> O <sub>5</sub>
Jan.		c.c.	gm.	gm.	gm.
14	Endogenous . . . . .	725	0.419	9.43	...
15	Endogenous . . . . .	720	0.448	10.25	1.94
16	Endogenous . . . . .	680	0.453	9.72	2.09
17	Endogenous . . . . .	755	0.496	9.70	1.73
	Average, endogenous period . . .	....	0.454	9.70	1.92
18	0.7 gm. para-oxy benzoic acid . . . .	855	0.139	9.63	1.50
19	2.0 gm. para-oxy benzoic acid . . . .	810	0.439	9.09	2.20
20	3.0 gm. para-oxy benzoic acid . . . .	1020	0.340	9.11	1.77
	Average, para-oxy benzoic period .	....	0.306	9.28	1.82
21	Endogenous . . . . .	775	0.439	10.29	1.74
22	Endogenous . . . . .	900	0.398	10.34	1.37
23	Endogenous . . . . .	810	0.356	....	1.75
24	Endogenous . . . . .	905	0.432	10.61	1.99
	Average, endogenous period . . .	....	0.406	10.41	1.71
26	2 gm. sodium salicylate . . . . .	805	0.534	11.26	1.95
27	3 gm. sodium salicylate . . . . .	805	0.586	10.39	1.74

other nitrogenous excretory products are apparently not affected by either compound.

Subject B was a medical student, thirty-two years of age and weighing 152 pounds, there being very little change in body weight

TABLE V.  
SUBJECT D.

Date.	Conditions.	Vol- ume.	Crea- tinin.	Uric acid.	Total N.	P <sub>2</sub> O <sub>5</sub>
March		c. c.	gm.	gm.	gm.	gm.
20	Endogenous . . . . .	1440	1.81	0.524	14.17	1.85
21	Endogenous . . . . .	1340	2.05	0.487	13.62	1.43
22	Endogenous . . . . .	960	1.85	0.367	....	1.81
23	Endogenous . . . . .	1200	1.74	0.436	....	1.48
24	Endogenous . . . . .	1300	1.83	0.419	....	1.72
	Average, endogenous . . . . .	....	1.86	0.447	13.90	1.66
25	2 gm. meta-oxy benzoic acid . .	950	1.60	0.338	13.70	1.49
26	4 gm. meta-oxy benzoic acid . .	1020	2.01	0.474	....	1.80
27	2 gm. meta-oxy benzoic acid . .	900	1.46	0.364	13.33	1.39
28	2 gm. meta-oxy benzoic acid . .	1360	2.30	0.438	14.13	1.58
29	2 gm. meta-oxy benzoic acid . .	1200	1.98	0.427	13.95	1.85
30	6 gm. meta-oxy benzoic acid . .	1040	1.62	0.445	17.03	1.89
	Average . . . . .	....	1.83	0.415	14.43	1.67
31	Endogenous . . . . .	1270	1.89	0.429	16.86	1.95
April						
1	Endogenous . . . . .	1040	1.64	0.413	12.80	1.64
2	Endogenous . . . . .	1100	1.92	0.398	13.60	1.74
3	Endogenous . . . . .	1100	1.64	0.454	15.90	1.09
4	Endogenous . . . . .	1000	1.69	0.420	16.00	1.77
	Average, endogenous . . . . .	....	1.76	0.423	15.03	1.64

during the experiment. As shown in Table IV, there was no change in metabolism which could be ascribed to the para-oxy benzoic acid, although the action of the ortho compound is clearly demonstrated. In the urine of the first day of administration of the para compound there was a marked drop in the quantity of uric acid, but inasmuch

TABLE VI.  
AVERAGES NOT GIVEN IN PRECEDING TABLES.

Sub- ject.		Dura- tion.	Crea- tinin.	Uric acid.	N in NH <sub>3</sub>	Total N.	P <sub>2</sub> O <sub>5</sub>
		Days.	gm.	gm.	gm.	gm.	gm.
A	1.5-5 gm. meta-oxy benzoic acid per day . . . . .	5	1.29	0.315	0.770	11.12	...
	No drug . . . . .	4	1.28	0.331	0.755	10.46	...
B	No drug . . . . .	3	1.35	0.370	0.421	9.27	1.65
	0.3-3 gm. meta-oxy benzoic acid per day . . . . .	3	1.35	0.421	0.350	8.01	1.73
	No drug . . . . .	4	1.26	0.379	0.354	7.64	2.06
	3 gm. meta-oxy benzoic acid per day . . . . .	3	1.36	0.392	0.432	7.73	1.97
A	No drug . . . . .	7	1.12	0.289	....	10.19	1.05
	2 gm. para-oxy benzoic acid per day . . . . .	2	1.12	0.298	....	9.13	1.47
	No drug . . . . .	3	1.05	0.275	....	9.47	1.04
B	No drug . . . . .	3	1.33	0.352	0.443	8.53	1.62
	0.7-2 gm. para-oxy benzoic acid per day . . . . .	3	1.46	0.370	0.274	7.30	1.45
	No drug . . . . .	2	1.45	0.427	0.378	6.95	1.59
D	No drug . . . . .	5	1.82	0.422	....	14.00	1.59
	2 gm. para-oxy benzoic acid per day . . . . .	2	1.75	0.428	....	14.38	1.44
	No drug . . . . .	3	1.80	0.452	....	15.75	1.91

as this was observed in no other case, nor with this subject on repetition of the experiment, and as the deficit appears in the urine of the next day, it would seem to be rather temporary retention than decreased elimination.

With Subject D, a medical student, twenty-six years old and weighing 185 pounds, is also shown, in Table V, that the meta compound, even in large doses, does not increase the uric acid output nor appreciably modify the other excretory products determined.

The averages of Table VI are of other series than those given above the experimental days of each subject being consecutive ones. They confirm the conclusions drawn from the former experiments. These conclusions may be summarized as showing that, although ortho-oxy benzoic acid (salicylic acid) increases the urinary uric acid, the meta and para acids do not affect its quantity nor that of the other excretory products so far as they were determined here. Furthermore, the relation of eliminated uric acid to phosphoric acid during the administration of the ortho acid or its derivatives indicates that its action is one of inhibition of the uricolytic rather than a stimulation of the nuclein cleaving ferment.

I am indebted to Dr. Clarence Van Epps and Mr. Fred Moore for assistance with some of the analytical work.

# THE INFLUENCE OF CALCIUM UPON THE PUPIL AND THE PUPILLOMOTOR FIBRES OF THE SYMPATHETIC NERVE.

BY JOHN AUER AND S. J. MELTZER.

[From the Department of Physiology and Pharmacology of the Rockefeller Institute  
for Medical Research.]

WHILE studying the influence of the salts of calcium and magnesium upon the development of rigor mortis we observed that the pupils of animals which had received intravenously solutions of calcium salts became contracted. Being interested in the effects of calcium upon the various organs and tissues of the animal body, we decided to make this incidentally observed phenomenon the subject of a special investigation. We studied at the same time the influence of calcium upon the cervical sympathetic nerve with reference to the effect of its stimulation upon the size of the pupils. We intend to give in this paper an account of the results we have obtained in these investigations.<sup>1</sup>

**Method.**—While in the studies upon rigor mortis various salts of calcium were employed and the injections were made into various species of animals, in the present series the observations were made only on rabbits, and as a calcium salt the chloride only was employed. The solutions were administered by intravenous injection mostly through the external jugular vein. In a few cases the injections were given through the ear vein. The calcium chloride was invariably employed in  $\frac{1}{8}$  molecular solution. As a rule the animal was etherized, tied on a holder, one external jugular vein exposed and a cannula tied into it, one sympathetic nerve or both were exposed, and then we waited until the animal had sufficiently recovered from the ether. The solution was permitted to run into the vein from a burette at the average rate of about 2 c.c.

<sup>1</sup> Short accounts appeared in the Proceedings of the Society for Experimental Biology and Medicine, 1907-1908, v, p. 86, and Zentralblatt für Physiologie, 1908, xxii, p. 245.

per minute. When administered through the ear vein, no etherization was necessary, and the injection was accomplished more rapidly. The stimulation of the sympathetic nerve was carried on by means of an induction coil.

The calcium myosis was also studied while the animal was under the influence of such mydriatics as atropin, cocain, and adrenalin; these were administered either by instillation or by intravenous injection either before or after the infusion of calcium chloride. Observations were also made upon the effect of ether and asphyxia on the behavior of the myosis in question.

### THE EXPERIMENTAL RESULTS.

**Calcium myosis.**—An intravenous infusion of calcium chloride caused invariably a narrowing of the pupils. The first unmistakable effects could be already noticed after an infusion of only 10 c.c. of the  $m/8$  solution, and as a rule 22 c.c. or a trifle more would be sufficient to contract the pupil to nearly a pin point. Outside of this striking effect the animal would be awake and might not yet show any definite toxic symptoms, and when the infusion was stopped at this point and the animal was taken off the board and left to itself without further experimentation, it would completely recover. The amount of the calcium solution which sufficed to bring on a maximum myosis varied in general with the size of the animal and the rate of injection, slower injections requiring larger quantities for the same effect. There were, however, very few normal animals in which 30 c.c. of the solution would not bring on a strong constriction of the pupil. With the development of the constriction the pupils gradually lose their susceptibility to light, and neither excitement nor struggles of the animal bring about any change in the width of the pupils. The strongly constricted pupil appears to be absolutely immovable. However, after finishing the infusion and suturing the wound, the removal of the rabbit from the holder seemed to cause in some animals a slight widening of the contracted pupil. This widening as indicated was very slight and mostly only temporary. Furthermore, in a few instances there appeared rather a slight increase of the constriction of the pupil immediately after the removal of the animal from the holder. At any rate, these changes were very slight and ephemeral. As a rule,



after the discontinuation of the infusion of the calcium, whether the animal remained on the holder or was removed from it, the attained constriction of the pupil remained practically unchanged for a period varying between fifteen minutes and an hour and a half or even longer, and further, as a rule, several hours passed before the pupil attained its normal size and its normal reaction to light. The following few abbreviated protocols will illustrate the statements:

*Experiment 1.* — White male rabbit, 1570 gm. Etherized and cannula inserted into left jugular vein.

11.35 A. M. Operation finished and ether discontinued.

11.50 A. M. Both pupils moderately contracted; started infusion of  $\text{CaCl}_2$  *m/8* from a burette.

11.57 A. M. 14 c. c. in; both pupils very small.

12.00 M. 21 c. c. in; stopped infusion; both pupils very small, nearly pin point.

12.10 P. M. Wound sutured and animal removed from table.

12.32 P. M. Both pupils still very small; animal sits up.

1.15 P. M. Both pupils small, but definitely wider.

2.40 P. M. Pupils almost normal.

3.15 P. M. Both pupils about normal, respond to light.

*Experiment 2.* — Gray, young, female rabbit, 850 gm. Ether; cannula in vein.

11.50 A. M. Operation finished; ether discontinued.

12.00 M. Both pupils moderately dilated; started infusion of  $\text{CaCl}_2$  *m/8*.

12.09 P. M. 12 c.c. in; both pupils definitely smaller.

12.13 P. M. 16 c.c. in; both pupils well contracted.

12.18 P. M. 21 c.c. in; stopped infusion; both pupils strongly contracted, but not pin point.

12.20 P. M. Wound sewed up and animal removed from board. Both pupils became wider than when on board; are still very contracted.

3.45 P. M. Both pupils practically normal size.

Although the weight of the animal in this last experiment was only a little above half the weight of the animal used in the other experiment, the effect of the calcium upon the pupil seemed to be stronger in the first than in the second animal. One of the reasons for this difference is to be found in the difference of the rate with which the infusion was permitted to go on in both animals. In the

first rabbit 21 c.c. of the solution was permitted to run in within ten minutes, while in the second rabbit about eighteen minutes were consumed for a similar quantity.

The following experiment demonstrates the dependence of the calcium effect upon the relation between the weight of the animal and the infused quantity of the solution.

*Experiment 3.* — Gray, female rabbit, 2650 gm.; cannula in anterior branch of external jugular vein; required very little ether.

10.10 A. M. Operation finished and ether discontinued.

10.30 A. M. Both pupils normal size; started infusion of  $\text{CaCl}_2$ .

10.42 A. M. 20 c.c. in; pupils smaller than normal.

10.48 A. M. 30 c.c. in; pupils getting smaller rapidly.

10.51 A. M. 35 c.c. in; stopped infusion; both pupils nearly pin point.

10.55 A. M. Wound sewed up, and animal removed from holder to the table; both pupils become slightly wider.

11.00 A. M. Pupils still well contracted; animal sits up, able to move about.

11.45 A. M. Both pupils almost normal size again.

In this experiment the rate of infusion was fairly rapid, 35 c.c. in twenty-one minutes. The weight of the animal, however, was more than one kilo greater than the weight of the animal in the first experiment. It had to receive therefore 35 c.c. of the calcium solution before the pupils became nearly pin point, and even then after the discontinuation of the infusion the pupils returned to their normal size in a much shorter time than that observed in the first experiment.

**The calcium effect upon the pupillomotor fibres of the sympathetic nerve.** — As mentioned before, we have in this investigation included the study of the effect of intravenous infusion of calcium on the pupillomotor action of the sympathetic nerve. One or both of the cervical sympathetic nerves were stimulated by induction currents of various strengths before, during, and after the infusion of the calcium solution, and the reaction of the pupils noted. In most cases the sympathetics were not cut or ligated centrally to the point of stimulation. Before stating the results of the effect of the infusion we should record very briefly one or two facts relating to the effects of stimulation of the normal (uninfluenced) sympathetic nerves. In the first place we should mention that the responses of

both nerves to stimulation run by no means parallel; that is, the same degree of current may often cause a different degree of reaction of the pupils to the stimulation of their respective nerves. In fact, we were sometimes confronted with animals in which either the right or the left sympathetic nerve would not react to any electrical stimulation. With regard to the vasomotor effect upon the blood vessels of the rabbit's ear S. J. Meltzer and Clara Meltzer<sup>2</sup> stated that "stimulation of the left sympathetic gave a distinctly better effect than stimulation of the right." The studies of the effect of stimulation of these nerves upon the pupils do not show such a preference for the left sympathetic nerve, at least as far as our present merely incidental observations show.

Another point worth mentioning refers to the effect of ether. While the animal was under the influence of ether, stimulation of the sympathetic nerves had frequently no effect whatsoever upon the pupil. This loss of irritability of the sympathetic nerves persisted in a variable degree for some time after the etherization was discontinued. As a rule, some time was permitted to pass after the etherization before the infusion of the calcium solution was started. In one or two cases after a few cubic centimetres of the solution had run in, the irritability of the sympathetic seemed to have improved and gave rise to an erroneous impression that calcium in small doses favors the irritability. However, such a favorable effect never occurred when a sufficient time was permitted to elapse after the stoppage of the etherization before the calcium infusion was begun.

Turning now to the relation of the calcium infusion to the effect of stimulation of the sympathetic nerves, we may state that, as a rule, under the influence of the calcium chloride the mydriatic effect of the stimulation of the sympathetic becomes greatly reduced. The reducing effect rarely becomes perceptible before 10 or 12 c.c. of the solution have run in. With the further infusion, however, in order to obtain a dilating effect the secondary coil of the apparatus has to be brought nearer and nearer to the primary coil, until 25 or 30 c.c. are run in, when even such a strong current as is obtained with a coil-distance of only 30 mm. produces no effect. In our preliminary communication we were inclined to assume that the irritability of the sympathetic nerves succumbs more readily

<sup>2</sup> S. J. MELTZER and CLARA MELTZER: *This journal*, 1903, ix, p. 66.

to the influence of the calcium than does the natural width of the pupil, that is, that the loss of irritability of the sympathetic may become manifest before the pupil shows a reduction in size. While such incidents have indeed occurred once or twice, an analysis of our entire material convinced us that such an unqualified statement is not well founded. On the contrary, there have been also instances in which the pupils were already considerably contracted, while the dilating effect of stimulation of the sympathetics was not yet strikingly reduced. Like the reduction in the size of the pupil, the reduction in the mydriatic effect of stimulation of the sympathetics depends upon the rate of flow of the infusion and of course also upon the relations between the weight of the animal and the injected quantity of the solution. The return of the irritability of the sympathetic occurs also in the same slow manner as was described for the return of the normal width of the pupil: it depends also upon the injected quantity of the calcium solution and the rate of injection. While in general it must be stated that there was a close parallelism between both kinds of effects of the calcium infusion, there were enough differences to justify the assumption that both reductions are due to different effects. We shall illustrate the chief points of the foregoing statement by the following abbreviated protocols of two experiments.

*Experiment 4.* — Gray female rabbit, 1695 gm. Ether; both cervical sympathetics isolated, intact; cannula in jugular vein. (Petzold coil, one Daniell cell.)

10.45 A. M. Operation finished; stopped ether.

11.00 A. M. Both sympathetics stimulated with 150 coil distance = good dilatation.

11.10 A. M. Both pupils moderately dilated; started infusion of  $\text{CaCl}_2$ .

11.18 A. M. 15 c.c. ran in; both pupils a little smaller than before; sympathetic with 150 c. d. = good dilatation.

11.22 A. M. 22 c.c. ran in; both pupils very small; both sympathetics with 90 c. d. = no response.

11.25 A. M. 30 c.c. ran in; stopped infusion; both pupils practically pin point; both sympathetics with 90 c. d. = no reaction.

(The experiment was continued with the intravenous injection of cocain.)

*Experiment 5.* — White male rabbit, 1907 gm. Ether; both sympathetic nerves isolated, intact; cannula in jugular vein.

- 3.36 P. M. Operation finished; stopped ether.  
 3.52 P. M. Both pupils moderately dilated; both sympathetics stimulated with 150 c. d.=good dilatation of pupils, left more prompt.  
 3.57 P. M. Started infusion of  $\text{CaCl}_2$  *m*/8.  
 4.05 P. M. 16 c.c. in; both pupils distinctly smaller.  
 4.07 P. M. 22 c.c. in; both sympathetics with 90 c. d.=no response.  
 4.09 P. M. Stopped infusion, 26.5 c.c. ran in; both pupils very small, almost pin point; both sympathetics with 30 c. d.=no effect.  
 (Experiment continued with intravenous injection of cocain.)

**The influence of ether upon calcium myosis.**— In studying the causes for some of the variations in the intensity of the calcium myosis we found that the degree of etherization of the animal has a marked influence on the development and reversion of the calcium myosis. When the infusion began while the animal was still under the influence of ether, the myosis would develop slowly and might not even attain a strong degree. This would come out more strikingly when the etherization was continued during the entire infusion. Under the influence of ether the myosis would also disappear more rapidly after the infusion had been discontinued. The following two experiments will illustrate some of the points mentioned:

*Experiment 6.* — White female rabbit, 2110 gm. *Ether given heavily*; canula in jugular vein; both sympathetics exposed, intact.

11.55 A. M. Operation finished; *ether continued*.

12.00 M. Left and right sympathetics 70=0.

12.13 P. M. Ether relaxed slightly; left sympathetic 70 = 0, 50 = strong dilatation; right 150, 130, 100 = prompt dilatation; ether pushed again.

12.16 P. M. Started infusion of  $\text{CaCl}_2$  *m*/8. •

12.23 P. M. 13 c.c. in; both pupils slightly smaller, still moderately dilated.

12.28 P. M. 22 c.c. in; both pupils as before, no increase in myosis; ether continued; lid reflex present, but reduced.

12.33 P. M. 29 c.c. in. Right sympathetic 100 = 0; 50 = dilated, left sympathetic 50 = 0; 20 = dilated.

12.34 P. M. 30 c.c. in; stopped infusion; both pupils moderately dilated; stopped ether, wound sewed up.

12.40 P. M. Both pupils respond to light, moderately dilated in shade.

*Experiment 7.* — Gray male rabbit, 1310 gm.; no ether; rabbit tied on Cannon board; both pupils moderately dilated.

12.20 P. M. Injected through ear vein about 23 c.c. of  $\text{CaCl}_2$  *m*/8; both pupils become pin point.

12.22 P. M. Injected into each of the hind legs, subcutaneously, 4 c.c. ether; animal removed from board.

12.24 P. M. Both pupils wider, but still well contracted; animal unable to get up.

12.25 P. M. Pupils more than  $\frac{1}{2}$  normal size, left wider than right.

12.30 P. M. (ten minutes after injection of  $\text{CaCl}_2$ ). Both pupils normal size, right pupil (faces window) slightly narrower; respiration good; lid reflex slight.

12.38 P. M. Animal dead; respiration stopped before heart.

**The action of mydriatics upon the calcium effect.** — We have tested the influence of mydriatics with relation to the above-described effect of calcium upon the pupil and the pupillomotor fibres of the cervical sympathetic. There are three different kinds of mydriatics, each of which exerts its influence through a special part of the pupillomotor mechanism. It is now generally accepted that atropin causes dilatation of the pupil by paralyzing the endings of the oculomotor nerve in the constrictor of the pupil; that cocain causes dilatation by stimulating the nerve endings of the sympathetic in the dilator muscle. Finally, that adrenin (adrenalin) causes mydriasis by stimulating the muscle of the dilator. These three different substances were tested by intravenous injection as well as by instillation into the conjunctival sacs. These substances were administered in one set of experiments shortly before the calcium infusion for the purpose of studying their influence upon the development of the calcium phenomena; in another set they were administered shortly after the phenomena made their definite appearance in order to study the disappearance of the latter under the influence of these mydriatics. The influence of adrenalin had to be studied in animals which were specially prepared for this purpose, *i. e.*, one of the superior cervical ganglia had to be removed at least twenty-four hours previous to the experiment. The adrenalin observations therefore were carried out in a separate set of experiments. The experiments with atropin and cocain, especially the instillations into the conjunctival sacs, were often carried out on the same animal, using one eye for one substance and the second eye for the other substance. We shall therefore describe our results with atropin and cocain practically together, using the same experiment for illustration of the results obtained with both of these substances.

**Atropin.**— Only very few experiments were made with intravenous injection of atropin; it caused no change whatever in the calcium effect. Instillation of atropin in the conjunctival sac *after* the calcium myosis was once established was never capable of changing the further course in any perceptible degree. When the pupils began to dilate, there was no difference between the two pupils; the atropinized pupil was not wider than its mate, which was used as control. Neither did it seem to accelerate the recovery of the irritability of the corresponding sympathetic nerve. Instillation of atropin *before* the beginning of the calcium infusion exerted undoubtedly some restraining effect upon the development of the calcium myosis. The pupil does not become as constricted as with calcium infusion alone, and even large doses of calcium did not under these circumstances bring the pupil to a maximal constriction. The reduction of the irritability of the sympathetic was also diminished, although here the neutralizing effect of the atropin was apparently less than on the calcium myosis. There were atropin experiments in which a fairly large dose of calcium finally reduced the irritability of the sympathetics to the same degree as with calcium alone, while the pupil remained only moderately constricted.

**Cocain.**— *After* the calcium effect upon pupils and sympathetic were well established, intravenous injections of 5 or 6 mgm. of cocain (which exerted an insignificant and only temporary effect upon the animal (twitching, restlessness, etc.), the irritability of the sympathetic showed a definite gain; strengths of currents which a few minutes before were without any effect showed now a definite dilatation. The irritability, however, remained far behind its original degree, that is, the degree which was established before the calcium infusion began. The myosis, however, is very little affected by cocain injections: the return to normal seemed to take the same course as without cocain injection. However, after each stimulation of the corresponding sympathetic the pupil retains its width unusually long.

When cocain was injected intravenously *before* the calcium infusion, the myosis which followed was moderately but definitely restrained. The reducing effect upon the irritability of the sympathetics apparently suffered also some restraint; this influence, however, was less manifest than in the cases where the cocain was injected *after* the infusion.

Instillation of cocain into the conjunctival sac *before* the infusion

of calcium had a strikingly neutralizing effect upon the action of the latter. In some instances the infusion of even twice the effective dose of calcium did not produce a characteristic myosis. In fact, in one or two cases the pupil remained as wide as normal and even slightly wider, although the pupil was never as wide as after instillation of cocain alone. While there was no doubt that calcium constricts even a cocainized pupil, the constriction was not comparable with that which was observed in a non-cocainized pupil. The calcium effect upon the stimulation of the sympathetic was also definitely reduced on the cocainized side, although this reduction seemed to be of a distinctly less degree than the one observed with relation to the myosis.

Instillation of cocain after the calcium myosis had developed had also a distinctly neutralizing effect, although perhaps not so striking as when instilled before the infusion. (For the effect of this instillation upon the stimulation of the sympathetic we find that our experiments permit no definite conclusions.)

The following experiments will illustrate some of the statements made with reference to the neutralizing actions of atropin and cocain:

*Experiment 8.* — Gray female rabbit, 1695 gm. Ether; cannula in vein; both sympathetics isolated, intact.

10.45 A. M. Operation finished; stopped ether.

11.00 A. M. Both sympathetics 150 c. d. = good dilatation.

11.10 A. M. Started infusion of  $\text{CaCl}_2$  *m/8*.

11.26 A. M. 30 c.c. in; stopped  $\text{CaCl}_2$ ; both pupils practically pin points; both sympathetics 50 = 0.

11.28 A. M. 5 mg. cocain injected into jugular, washed down with 2 c.c. saline; very slight twitching of legs and ears.

11.29 A. M. Very slight widening of the pupils.

11.31 A. M. Both sympathetics 50 = fair dilatation; pupils remain wider than before.

*Experiment 9.* — Black male rabbit, 1525 gm.; ether; cannula in jugular vein.

1.16 P. M. Started  $\text{CaCl}_2$  *m/8*.

1.28 P. M. 21 c.c. in; stopped infusion; both pupils very small; instilled 2 per cent cocain in left eye only; right eye control.

1.35 P. M. Wound sutured, removed from board; left pupil a little wider now, right as before.

1.38 P. M. Instilled cocain again into left eye.



1.55 P. M. Right pupil very small; left pupil about four times larger than right.

2.00 P. M. Instilled a few drops of cocain again into left eye.

2.11 P. M. Right pupil same widening, but still well contracted; left pupil well dilated, *wider than normal*.

*Experiment 10.* — White female rabbit, 1750 gm. Ether; cannula in jugular vein; both sympathetics isolated, intact.

10.45 A. M. Instilled cocain (2 per cent) into left eye and atropid sulphate (1 per cent) into right eye.

10.55 and 11.13. Instilled again as before.

11.20 A. M. Cocain pupil now a little larger than atropin pupil. Left sympathetic 120 = good dilatation; right sympathetic 120 = same additional dilatation.

11.22 A. M. Started infusion of  $\text{CaCl}_2$  *m/8*.

11.27 A. M. 9 c.c. in; cocain pupil much wider than atropin pupil.

11.29 A. M. 13 c.c. in; both sympathetics 120 = dilatation right better than before.

11.34 A. M. 30 c.c. in; both sympathetics 120 = dilating slowly.

11.36 A. M. 34 c.c. in; atropin pupil smaller than before; cocain pupil strongly dilated.

11.38 A. M. 37 c.c. in; left sympathetic (cocain) 120 = dilatation; right (atropin) 120 = 0, 70 = slight.

11.44 A. M. 45 c.c. in; cocain pupil much wider than atropin pupil.

11.52 A. M. 60 c.c. in; right (atropin) pupil half the size of left; left sympathetic 120 = dilates well; right sympathetic 50 = slight dilatation after same stimulation.

*Experiment 11.* — White male rabbit, 1885 gm. Ether; cannula in vein; both sympathetics isolated, intact.

10.55 A. M. Both sympathetics 150 = good dilatation.

11.02 and 11.10 A. M. Instilled cocain in left and atropin in right eye.

11.41 A. M. Atropin pupil well dilated; cocain pupil only moderately dilated, responds well to light; both sympathetics 150 = dilatation, better on cocain side.

11.44 A. M. Started  $\text{CaCl}_2$  *m/8*.

11.49 A. M. 14 c.c. in; cocain pupil wider now than atropin eye.

11.57 A. M. 34 c.c. in; both sympathetics 90 = dilate only slightly.

12.00 M. 40 c.c. in; cocain pupil three times as large as the atropin pupil.

12.07 P. M. 53 c.c. in; both sympathetics 90 = slight dilatation, left sluggish.

12.10 P. M. 59 c.c.; right pupil smaller than before, left pupil a little wider than normal.

12.15 P. M. 68 c.c.; both sympathetics 50 = 0; right pupil (atropin) small (not as small as with Ca alone); left pupil (cocain) *a little wider than normal*, much larger than right pupil.

**The relation of the superior cervical ganglion and adrenalin to the calcium myosis.** — In 1898 Lewandowsky<sup>3</sup> observed that an intravenous injection of suprarenal extract produced a dilatation of the pupil, the maximum of which lasted only a fraction of a minute. This effect was well pronounced in cats and less definite in rabbits. This observation was soon confirmed by Boruttau,<sup>4</sup> Langley,<sup>5</sup> and others. It was further established that subcutaneous injection of the extract or its instillation fails to act on the pupil. In 1903 S. J. Meltzer and Clara Meltzer (Auer)<sup>6</sup> have found that, twenty-four hours after removal of the corresponding superior cervical ganglion, subcutaneous injections as well as instillations of the extract (adrenalin) cause a maximum dilatation of the pupil even in rabbits, and that the dilatation produced by these methods as well as by intravenous injection persists for many hours. Meltzer and Auer<sup>7</sup> have shown later that intramuscular injections of adrenalin work nearly as rapidly as intravenous injections. Lewandowsky and Langley, as well as the Meltzers, assumed that the dilatation which is produced by the extract is caused by the stimulation of the muscle substance of the dilator pupillæ. This assumption is now generally accepted. The Meltzers have further assumed that normally the superior cervical ganglion sends inhibitory impulses to the dilator muscle, which thus greatly restricts the efficient stimulation of that muscle by the suprarenal extract. This theory now also meets with an extended approval.

In our present investigations the questions arose: What influence upon the development of the calcium myosis would be exerted: (1) by the simple removal of the superior cervical ganglion; (2) by the injection or instillation of adrenalin with the ganglion present; and (3) by the injection or instillation of adrenalin twenty-four hours

<sup>3</sup> LEWANDOWSKY: *Archiv für Physiologie*, 1899, p. 360.

<sup>4</sup> BORUTTAU: *PFLUEGER'S Archiv*, 1899, lxxxviii, p. 112.

<sup>5</sup> LANGLEY: *Journal of physiology*, 1901-1902, xxvii, p. 237.

<sup>6</sup> CLARA MELTZER and S. J. MELTZER: *Proceedings of the Society of Experimental Biology and Medicine*, Feb. 28, 1903, xiii; *Centralblatt für Physiologie*, 1903, xvii, p. 651; *This journal*, 1904, xi, p. 28.

<sup>7</sup> S. J. MELTZER and J. AUER: *Journal of experimental medicine*, 1905, vii, p. 59.

and longer after the cervical ganglion has been removed? The experiments which were made to answer the above questions brought out, briefly stated, the following results:

1. The removal of a superior cervical ganglion does not restrain the development of calcium myosis. On the contrary, it seemed that in the absence of the ganglion the myosis attained its maximum with a smaller dose of the calcium solution.

2. Intravenous injection of adrenalin in normal animals (ganglion present) does not interfere with the calcium effect, either upon the width of the pupil or the irritability of the sympathetic nerve, whether the injection is administered before or after the efficient calcium infusion.

3. Intravenous or intramuscular injections of adrenalin before the calcium infusion in animals freed from one ganglion causes, upon the side where the ganglion was removed, *during* the infusion, a very moderate restraint, if any, upon the development of the myosis. After the discontinuation of the infusion, however, the pupil on the ganglion-free side dilates distinctly more rapidly than the pupil on the normal side.

4. Intravenous injection of adrenalin after the calcium infusion in a ganglion-free rabbit causes a marked hastening of the dilatation of the pupil on the ganglion-free side.

5. Instillation of adrenalin before the calcium infusion exerts very little restraint upon the development of the calcium myosis in the pupil of the ganglion-free side. They hasten somewhat the dilatation of that pupil after the discontinuation of the effusion, but this effect is much less than that observed after the intravenous injection of adrenalin.

(The observations on instillations of adrenalin after the calcium infusion do not permit any general conclusions.)

We append here a few abbreviated protocols of experiments which will illustrate some of the points mentioned.

*Experiment 12.* — Gray female rabbit, 1425 gm. Right superior cervical ganglion removed four days ago; ether; cannula in vein; left sympathetic nerve isolated.

10.05 A. M. Intramuscular injection of adrenalin; soon right pupil strongly dilated, left pupil moderately contracted.

10.16 A. M. Stopped ether.

10.30 A. M. Left sympathetic 120 c. d. = pupil dilates.

10.36 A. M. Started infusion of  $\text{CaCl}_2$   $m/8$ ; right pupil well dilated, left moderately dilated.

10.47 A. M. 20 c.c. in; both pupils contracted, left smaller than right.

10.50 A. M. 24 c.c. in; stopped calcium infusion; left sympathetic 70, 50 c. d. = slight.

10.55 A. M. Removed from board: left pupil practically pin point, right contracted but far from pin point.

11.55 A. M. Right pupil moderately dilated, left pupil still strongly contracted.

12.20 P. M. Right pupil well dilated, left still strongly contracted.

*Experiment 13.* — Red-gray male rabbit, 1280 gm. Left superior cervical ganglion removed twenty-four hours before; ether cannula in vein; right sympathetic isolated, intact.

2.28 P. M. Operation finished; stopped ether.

2.52 P. M. Right sympathetic 150 = prompt good dilatation.

2.53 P. M. Started  $\text{CaCl}_2$   $m/8$ .

3.02 P. M. 16½ c.c. in; both pupils practically pin point.

3.04 P. M. 19 c.c. in; stopped infusion.

3.09 P. M. Injected 0.4 c.c. adrenalin into jugular vein, washed down with 2 c.c. saline.

3.15 P. M. Left pupil moderately dilated, right pin point.

4.45 P. M. Left pupil well dilated, larger than normal; right pupil wider than before, but still well contracted.

*Experiment 14.* — White male rabbit, 1720 gm. Left superior cervical ganglion removed eleven days before; ether; cannula in jugular vein; right sympathetic exposed, intact.

10.10 A. M. Operation finished; stopped ether.

10.15 A. M. Right sympathetic 130 = good, prompt dilatation.

10.41 A. M. Started  $\text{CaCl}_2$   $m/8$ .

10.45 A. M. 7 c.c. in; both pupils smaller, about equal.

10.48 A. M. 14 c.c. in; both pupils still smaller, left distinctly smaller.

10.50 A. M. 19 c.c. in; both very small, left smaller.

10.51 A. M. 21 c.c. in; stopped infusion; right sympathetic 100 = 0.

10.52 A. M. 0.6 c.c. adrenalin into jugular vein, 2 c.c. saline.

10.55 A. M. Left pupil dilated slightly, right pupil seemed to get smaller.

10.56 A. M. Right sympathetic 150, 100 = 0.

11.12 A. M. No change in right, very small, almost pin point; left pupil about twice the size of right.

11.22 A. M. Right pupil same, almost pin point; left pupil four to five times the size of right.

11.55 A. M. Left pupil almost normal in size; right pupil practically pin point.

12.05 P. M. Left pupil still wider, *wider than normal*; right pupil very small, no change.

1.10 P. M. Left pupil well dilated, more than before; right pupil very small.

1.55 P. M. As before; left pupil does not respond to light.

3.35 P. M. As before; right pupil practically pin point still; left pupil moderately dilated, responds slightly to light.

*Experiment 15.* — Gray female rabbit, 1220 gm. Right superior cervical ganglion removed twenty-one days before.

10.15, 10.40, and 10.50. Instilled adrenalin in each eye.

11.10 A. M. Right pupil dilated ad maximum, left apparently larger than normal.

11.45 A. M. Injected slowly through ear vein 35 c.c.  $\text{CaCl}_2$  *m/8*; both pupils strongly contracted; left pupil almost pin point, right a trifle wider than left.

12.30 P. M. Both pupils very small, about equal, and quite pin point.

2.10 P. M. Both pupils have widened; right larger than left and larger than before instillation; left a trifle less than normal.

**Asphyxia.** — As is well known, the normal pupils dilate during asphyxia, the dilatation as a rule being maximal or nearly so. In our investigation of the calcium myosis we have not made a direct study of the behavior of this myosis under the influence of asphyxia. We have, however, in the course of the present series of experiments, noted a number of cases in which one or the other animal suffered temporarily from or died under symptoms of asphyxia (convulsions, pulmonary œdema, etc.). By collecting and analyzing these incidental observations we are enabled to offer the following statement relative to the influence of asphyxia upon calcium myosis. When the infusion was still in progress and the myosis already well established, a temporary asphyxia due to a convulsion or a terminal asphyxia due to impending death caused only a slight widening of the pupil. The same was the case when asphyxia occurred after the discontinuation of the infusion, but only when the myosis showed a strong or fair tendency to persistence. There was, for instance, not a single case of strong or even fair dilatation of the pupil by asphyxia within an hour after the infusion when the animal received atropin either before or after the infusion of calcium. However, if the myotic pupil manifested already a

definite tendency towards dilatation, asphyxia did not fail to call forth a distinct additional widening of the pupil. This was especially manifest in cocain or adrenalin experiments, when the pupil began to dilate spontaneously. In other words, the mydriatic factor of asphyxia was of little account in antagonizing the calcium myosis when the intensity of the latter was not yet reduced. However, it became effective when the myosis was already otherwise weakened, or was originally only of moderate intensity. We have to add, however, that cases of myosis which were temporarily attacked by asphyxia have shown a tendency to an early return to normal, even if at the time of the attack the effect of asphyxia was very little manifest. The mydriatic action of asphyxia was therefore practically never completely lost in the process of antagonizing the calcium myosis.

**The effect upon the palpebral aperture.**— We have yet to record the fact that, besides the effect upon the pupil, the infusion of the calcium had a definite effect upon the tonus of the lids. In all cases when the infusion of calcium produced a definite myosis, the lids became (and remained) widely separate. Whereas at the beginning of the infusion closure of the lids often hampered the proper observation of the pupils, there was no such difficulty during the further progress of the infusion: the palpebral aperture was wide open and was rarely interrupted by spontaneous winking, although the lid reflex remained active. The same holds true also for the third lid; when the myosis was advanced, the retraction of the third lid was complete.

#### DISCUSSION.

Before we enter into a discussion of the meaning of our observations, we shall first recapitulate briefly the main facts which our investigations brought to light.

An intravenous infusion of an M/8 solution of  $\text{CaCl}_2$  produces a very strong myosis, and abolishes or greatly reduces the irritability of the pupillomotor fibres of the sympathetic nerves. Asphyxia neutralizes the myosis only when it is already otherwise perceptibly weakened. Ether seems to neutralize the myosis to a somewhat greater degree than asphyxia. Atropin antagonizes the calcium effect only by instillation and altogether only to a very moderate extent. Cocain neutralizes the calcium effect better than any other mydriatic, also chiefly by instillation. It retards greatly the develop-

ment of the myosis, restrains the depression of the irritability of the sympathetic, and hastens the reversion of both after the discontinuation of the calcium infusion. The neutralizing effect of adrenalin upon the myosis of a pupil, the corresponding superior cervical ganglion of which was removed, stands between that of cocain and atropin, but it acts best through intravenous injection.

What is the cause of the calcium myosis, that is, which part of the pupillomotor mechanism is affected by calcium and in which manner? The normal pupil can be made to contract either through a stimulation of the constricting part of the apparatus or through an inhibition of the dilating part of it. There is normally a dilating tonus of the mechanism; this is demonstrated by the fact that cutting of the cervical sympathetic causes a constriction of the pupil. There might be some reasons for an assumption that the calcium influence in the production of the contraction of the pupil is of an inhibitory character. The contractions of a frog muscle after being immersed in a solution of sodium chloride are inhibited through the addition of some calcium chloride (Ringer, J. Loeb). Furthermore, according to J. B. McCallum, calcium inhibits the peristaltic movements of the intestines, that is, the movements of an apparatus in which smooth muscle and sympathetic nerve fibres are parts of its motor mechanism, and therefore in a way similar to the motor mechanism of the iris. However, it seems quite certain that the inhibition of the dilating tonus cannot be the cause of the calcium myosis, at least not its essential cause. The myosis following the calcium infusion is incomparably greater than the narrowing of the pupil which follows the section of the sympathetic or the removal of the superior cervical ganglion. There must be, therefore, an additional essential factor for the constriction of the pupil by calcium besides the inhibition of the dilating tonus. Besides, in some instances some time after the removal of the ganglion and probably also after complete degeneration of the sympathetic nerve endings, the corresponding pupil was often wider than on the other side. In these cases, without any nervous mechanism for a dilating tonus, the infusion of calcium did not fail to cause a strong myosis; *in fact, the effect seemed to appear more promptly in such cases.* It is therefore quite evident that it is in the constricting section of the pupillomotor mechanism where the cause for the calcium myosis must be sought, and that the action of the calcium must be of a stimulating and not of an inhibiting character.

In the constricting section of the mechanism we have to distinguish three parts, the stimulation of any one of which could cause myosis. The constriction could come through a stimulating action of the calcium either upon the substance of the constrictor muscle, or upon the endings of the short ciliary nerves within this muscle, or, finally, in any part of the nervous mechanism lying centrally to the nerve endings. Within the last-named part we could again distinguish nerve fibres, ciliary ganglion, and nerve centres lying centrally to the ganglion. But we can afford to omit discussing these details, as we can easily prove that none of the parts lying centrally to the nerve endings can be concerned in the calcium myosis, at least not to an essential degree. The proof is this. It is now well established that the mydriasis which is brought on by atropin is caused by a paralysis of the motor nerve endings of the constrictor muscle. We have stated above that atropin is capable of overcoming the calcium myosis only in a very small degree. However, such a myosis, which is caused by an action that is taking place centrally to the nerve endings, would be completely abolished by a paralysis of the nerve endings. The action of the calcium in producing myosis must therefore be either on the nerve endings or on the muscle itself.

There are, further, a number of facts which make it appear improbable that the myosis is chiefly due to a stimulation of the nerve endings. It is now fairly securely established that the myosis produced by physostigmin is caused by a stimulation of the nerve endings by that substance. If now atropin is instilled into an eye, the pupil of which is strongly contracted through a previous instillation of physostigmin, the pupil will become dilated nearly as much as if there had not been any previous myosis present. Here we see that atropin which paralyzes the nerve endings is capable of overcoming a strong stimulation of these organs by another substance. In our experiments we have found that atropin affects only slightly the calcium myosis. Now, if the myosis were caused only by a stimulation of the nerve endings, why should atropin not overcome it nearly completely? Furthermore, instillation or intravenous injections of adrenalin, which causes a maximal dilatation of the pupil, the corresponding superior cervical ganglion of which was previously removed, overcomes completely the myosis previously produced by physostigmin. This fact is well assured through statements in literature and through manifold experience of our own.



The effect of physostigmin is on the nerve endings of the constrictor muscle, that of adrenalin on the muscle substance of the dilator. Here we see that contraction of the dilator caused by a stimulation of its substance can completely overcome the contraction of the constrictor brought about by a stimulation of its nerve endings. The neutralization of the calcium myosis by the injection or instillation of adrenalin in gangliectomized rabbits is strikingly deficient. But if the calcium myosis were also due to a stimulation of the nerve endings of the constrictor, why should its neutralization not be complete or rather even reversed into mydriasis?

Here we may also refer to the fact that asphyxia and death overcome readily the myosis due to physostigmin, while they cause very little change upon the myosis brought about by calcium.

The various circumstances therefore seem to point inevitably to the conclusion that the myosis after infusion of calcium is brought about by a stimulation of the muscle of the constrictor pupillæ. We certainly can understand, then, why atropin has so little effect upon this myosis: the paralysis of nerve endings of the constrictor cannot interfere with a contraction which is caused by a stimulation of the muscle substance. However, if calcium stimulated the muscle alone, there would be no reason why atropin should then have even a slight effect upon the myosis produced by it, whereas our experiments demonstrated that, especially when atropin was instilled before the calcium infusion began, the development of the myosis was unquestionably interfered with. To meet this objection, the additional assumption has to be made that besides the muscle substance calcium stimulates also the nerve endings of the constrictor. The assumption which we offer reads, then, that *the myosis is produced by a simultaneous stimulation of nerve endings and muscle tissue of the constrictor of the pupil by the excess of calcium*. A substance like atropin, which promptly overcomes the stimulations of the nerve endings, would therefore reduce the degree of the myosis produced by calcium. It is possible that the calcium stimulation of the muscle tissue is more intense than that of the nerve endings. Hence the only moderate reduction of the calcium myosis by the instillation of atropin. However, it is not necessary to enter at present into a discussion of the merits of this special point.

There is nothing that we can think of which would militate against the assumption that besides the muscle tissue of the constrictor its nerve endings are also being stimulated by calcium.

On the other hand, this assumption will facilitate the understanding of the further fact that adrenalin which can overcome in the gangliectomized rabbit nearly completely the myosis produced by eserine should affect only moderately the myosis produced by calcium. The contraction of the dilator of the pupil brought about by a stimulation of only its muscle substance by adrenalin cannot completely overcome the strong contraction of the constrictor brought about by a simultaneous stimulation of the muscle and its nerve endings. On the same basis we can understand without a detailed argumentation why asphyxia which overcomes the myosis of eserine affects only moderately the calcium myosis.

With regard to the "nerve endings" of the sphincter we ought to refer to the distinction made by H. K. Anderson,<sup>8</sup> namely, that these "endings" consist of two parts: a more centrally located part which is the point of attack by eserine, and a peripherally located part of the "endings" which is stimulated by pilocarpin and paralyzed by atropin. Applying this subdivision to the subject under discussion, it may be assumed that it is only the peripheral part of the nerve endings which is stimulated by calcium simultaneously with the contractile substance. This would in a way be more acceptable, since this peripheral part is supposed to have closer affiliation with the muscular tissue. On the other hand, we would have to insist that it is not this part alone which is affected by calcium, since atropin paralyzes it, while atropin does not overcome the calcium myosis.

There is one fact among our observations which offers some difficulty in its explanation. It is the observation that cocaine neutralizes the calcium myosis better than atropin and better even than adrenalin. From the fact that atropin and adrenalin, which readily overcome the effects of eserine myosis, exert only a moderate effect upon the calcium myosis, the impression may be gained, at least in a general way, that the calcium myosis is more resistant than the myosis produced by eserine. But here we are confronted with the fact that cocaine, the mydriasis of which is readily overpowered by eserine, is more capable of antagonizing the calcium myosis than the more powerful mydriatics atropin and adrenalin, which would thus seem to indicate the reverse, namely, that the resistance of the calcium myosis is less strong than that produced by eserine. The

<sup>8</sup> H. K. ANDERSON: *Journal of physiology*, xxxii, Proceedings of the Physiological Society, 1905, xlix; 1905-1906, xxxiii, p. 414

comparison of the actions of cocain and adrenalin seems to be especially puzzling. Cocain is assumed to act by stimulation of the nerve endings and adrenalin by stimulation of the muscle of the dilator. Cocain neutralizes the calcium myosis a good deal better than adrenalin. Can we assume that a contraction of the dilator produced by stimulation of the nerve endings is stronger than one which is produced by the direct stimulation of the muscle? But we might indeed be inclined to answer this query in the affirmative, remembering the fact that for the frog muscle, in order to bring out a certain degree of contraction, the direct stimulation requires a stronger stimulus than the indirect. However, in the present fermenting state of our knowledge regarding the nature of "nerve endings," "myo-neural junction," "receptive substances," etc., we hardly know what is meant by the statement that adrenalin stimulates the muscle cells and cocain the nerve endings, and can therefore not discuss satisfactorily these differences.

We may add, further, that the experiments which led to the conclusion that cocain acts on the pupil by stimulation of the nerve endings of the dilator of the pupil have only considered and eliminated the possibility that the dilatation, which is brought on by cocain, is caused by a paralysis of the motor nerves of the constrictor. There is, however, another possibility which, as far as we know, has not yet been even considered. The assumption is entertained by many physiologists and ophthalmologists that the normal process of dilatation of the pupil is aided by an inhibition of the constrictor of the pupil, that is, that with each motor impulse to the dilator runs simultaneously an inhibitory impulse to the constrictor, thus causing a dilatation of the pupil without any wasteful struggle of the antagonistic muscles. May not the effect of cocain consist in a similar action, that is, in a simultaneous stimulation of the motor mechanism of the dilator and the inhibitory mechanism of the constrictor, — in other words, may not cocain stimulate not only the motor nerves of the dilator muscle, but *stimulate the entire mechanism of dilatation*? If this be the case, cocain would effect the neutralization of the calcium myosis by causing a contraction of the muscle dilator, inhibiting at the same time, at least in some degree, the contraction of the constrictor of the pupil. We could then readily understand why such an action should be more effective than the action of adrenalin, which causes only a contraction of the dilator muscle. However, we have for the present no new

facts in support of this hypothesis and shall not enter into a further discussion of its merits.

Our experiments brought out the further fact that under the influence of the infusion of calcium the cervical sympathetic gradually loses its dilating action upon the pupil. This might be interpreted in two ways. It might mean that under the influence of calcium the pupillomotor fibres of the sympathetic become paralyzed, which would mean that calcium exerts here an action entirely different from and independent of the one which causes myosis. But it could also mean that the impulses of the sympathetic to the dilator muscle, which even under the influence of calcium remain normal, are insufficient to cause a dilatation of the pupil on account of the inability of the dilator to overcome the strong contraction of its antagonist, the constrictor. We have already indicated at the outset that in general there was a certain parallelism between the development of the myosis and the reduction of the irritability of the sympathetic nerves. For instance, the quantity of calcium which brought out one phenomenon was generally sufficient to permit the appearance of the other phenomenon. This and other similar facts speak in favor of the assumption that there is a close interdependence of both phenomena. On the other hand, there were a number of instances in which the myosis remained practically unaffected while the sympathetic nerve manifestly regained its irritability to a considerable degree. While, on the basis of the general impression which we gained from our observations, we are rather inclined to accept the assumption that the loss of the irritability of the sympathetic nerves is indeed a phenomenon independent of the development of the calcium myosis, the meagreness and indefiniteness of the concerned facts prevent us at this stage of the work from going on record with such a positive statement. Future investigations may throw more light on that subject.

#### SUMMARY.

An intravenous infusion of an  $m/8$  solution of  $\text{CaCl}_2$  causes invariably a maximal contraction of the pupils. The myosis may be completely developed at a stage of the infusion when no other signs of a calcium intoxication are present. With the development of the myosis the pupil loses its responsiveness to light and to other

physiological myotic or mydriatic reactions. The myosis is apparently due essentially to a stimulation of the muscle of the constrictor of the pupil. It is probable that also the motor nerve endings are stimulated to some degree by the calcium. (Perhaps only the mural part of the nerve endings (H. K. Anderson) is affected.)

Parallel to the development of the myosis the palpebral aperture becomes stationary and wider, and the "winking" becomes rare, although the lid reflex proper may still be entirely unaffected.

The infusion of calcium reduces also greatly the irritability of the pupillomotor fibres of the cervical sympathetic nerves. It is fairly probable that the loss of irritability of the sympathetic is an independent phenomenon and not simply a consequence of the strong myosis.

After discontinuation of the infusion the calcium effects may continue in their maximal degree for an hour and longer, and many hours may pass before the pupils return to their normal condition.

Atropin neutralizes the myosis only to a very small degree, and this only by instillations carried out before the beginning of the calcium infusion.

Cocain, by instillations as well as by intravenous injections, exerts a much more evident neutralizing action upon the calcium effects than atropin. It retards their development and accelerates their disappearance. However, even the neutralizing action of cocain must be designated as only moderate.

Intravenous or intramuscular injections or instillations of adrena-  
lin exert also a definite neutralizing action upon the calcium effects in gangliectomized animals. The degree of the action stands between that of atropin and cocain.

Ether frequently retards the development and hastens the disappearance of the calcium myosis.

Asphyxia overcomes only to a very limited degree a well-developed calcium myosis; it favors, however, its early disappearance.

## CERTAIN ASPECTS OF CARBOHYDRATE METABOLISM IN RELATION TO THE COMPLETE REMOVAL OF THE THYROIDS AND PARTIAL PARTHYROIDECTOMY.

By FRANK P. UNDERHILL AND WARREN W. HILDITCH.

[From the Sheffield Laboratory of Physiological Chemistry, Yale University.]

THE function of the ductless glands still comprises one of the vague and obscure chapters of physiology, despite the active investigation which has been devoted to the subject. Especially confusing and contradictory have been the views promulgated with respect to thyroid function and its importance in the maintenance of nutritional rhythm. A new significance was attached to the thyroid function when it was recognized that the thyroids and parathyroids may have an independent importance and perhaps may not be reciprocally interchangeable functionally.

Of the recent attempts to determine the office of the thyroid the endeavor to solve the relation of these glands to carbohydrate metabolism has proved preëminently attractive. Particularly interesting is the relation of these glands to the assimilation powers of the organism for dextrose. R. Hirsch<sup>1</sup> has shown that after complete thyroidectomy the assimilation limit for dextrose given by mouth is significantly decreased in dogs. Underhill and Saiki<sup>2</sup> demonstrated a decreased capability for the utilization of dextrose subcutaneously introduced in dogs after removal of both thyroids and parathyroids. In these latter experiments the attainment of thyreoparathyroidectomy was indicated by the fact that all the animals rapidly developed tetany and died.

That the thyroids and parathyroids differ in their influence upon carbohydrate utilization was pointed out by R. Hirsch.<sup>3</sup> From

<sup>1</sup> R. HIRSCH: *Zeitschrift für experimentelle Pathologie und Therapie*, 1906, iii, p. 393.

<sup>2</sup> UNDERHILL and SAIKI: *Journal of biological chemistry*, 1908, v, p. 225.

<sup>3</sup> R. HIRSCH: *Zeitschrift für experimentelle Pathologie und Therapie*, 1908, v, p. 233.

these more recent observations the conclusion was drawn that although thyreoparathyroidectomy leads to a lowering of the assimilation limit for dextrose, thyroidectomy, with undisturbed parathyroids, produces no such effect. In experiments by Eppinger, Falta, and Rudinger<sup>4</sup> it is also shown that thyroidectomy does not lower the assimilation limit for dextrose in dogs, an observation which has been further corroborated by Pari.<sup>5</sup> It was later<sup>6</sup> likewise demonstrated that extirpation of three parathyroids causes a diminished assimilative power for dextrose, and that the removal of three parathyroids plus one thyroid produced no greater influence in this direction than was observed after extirpation of three parathyroids alone. This series of observations therefore makes it apparent that the parathyroids in particular are intimately associated with carbohydrate metabolism.

From a different viewpoint the relation of the thyroids and parathyroids to carbohydrate metabolism has been investigated by Eppinger, Falta, and Rudinger.<sup>7</sup> They have reported that after the extirpation of the thyroids in dogs large doses of adrenalin administered subcutaneously or intraperitoneally fail to call forth glycosuria, even though the animals had previously consumed large quantities of carbohydrates. It was also demonstrated that after feeding thyroid tissue to thyroidectomized dogs adrenalin behaved in its accustomed manner and glycosuria resulted. A critical examination of the data presented shows, however, that the thyroidectomized dogs that had been fed on thyroid tissue had not previously been tested with adrenalin; and in these specific instances there is no *direct* evidence that the doses of adrenalin used would not have produced glycosuria without the thyroid feeding. In a second communication the same authors<sup>8</sup> report that although adrenalin fails to cause sugar excretion in the urine after the administration of adrenalin to dogs after removal of the thyroids alone, glycosuria results after the administration of adrenalin to dogs in which thyreoparathyroidectomy has been performed. On the other hand,

<sup>4</sup> EPPINGER, FALTA, and RUDINGER: Wiener klinische Wochenschrift, 1908, p. 241, and Zeitschrift für klinische Medizin, 1908, lxvi, p. 1.

<sup>5</sup> PARI: Biochemische Zeitschrift, 1908, xiii, p. 281.

<sup>6</sup> EPPINGER, FALTA, and RUDINGER: Zeitschrift für klinische Medizin, 1909, lxvii, p. 1.

<sup>7</sup> EPPINGER, FALTA, and RUDINGER: *Ibid.*, 1908, lxvi, p. 1.

<sup>8</sup> EPPINGER, FALTA, and RUDINGER: *Ibid.*, 1909, lxvii, p. 1.

Pick and Pineles<sup>9</sup> have shown that rabbits whose thyroids have been removed still react normally to adrenalin and excrete urine containing sugar, whereas adrenalin fails to provoke glycosuria in young goats after thyroidectomy.

The somewhat conflicting data on the relation of the glandular structures under discussion to carbohydrate metabolism are far from convincing, and awaken a reasonable skepticism regarding the far-reaching consequences which have been interpreted into them. This attitude is now fully justified by our own experiments, which are reported below in detail.

#### EXPERIMENTAL.

**Methods.**— The thyroids and parathyroids of the dog are so closely associated anatomically that extirpation of the thyroids without injury to all the parathyroids is at times extremely difficult. The method employed to accomplish this was as follows: The capsule containing the glands was carefully torn off by means of a pair of fine forceps. By the same means the connective tissue binding the outer parathyroid to the thyroid was carefully dissected from around the parathyroid. As soon as a small portion of the parathyroid had been freed from the thyroid in this way, a very fine silk thread was placed under the parathyroid, and by a sawing motion of the silk thread parallel with the thyroid aided by dissection the parathyroid and its intact blood vessel was separated from the thyroid. The extirpation of the thyroid was then a simple matter, consisting merely in ligation of the blood vessels and removal of the gland. In most of our experiments the outer parathyroid only on each side was left intact, since the inner parathyroid is at times practically invisible. In some animals, however, it was easier to leave the inner parathyroid than the other. After removal of thyroids the wound was sewed up, covered with collodion, and bandaged. At intervals of one or two days the wound was dressed and in each case healed rapidly. For the success of our extirpation experiments we are deeply indebted to Prof. Lafayette B. Mendel, who assisted us in the removal of the thyroids.

Unless otherwise specified, the adrenalin solution employed was the product of Parke, Davis & Company, and was as fresh as could be obtained. Sugar in the urine was estimated with a Schmidt and

<sup>9</sup> PICK and PINELES: *Biochemische Zeitschrift*, 1908, xii, p. 473.



Haensch triple shadow saccharimeter, readings being taken before and after fermentation with yeast.

DOES ADRENALIN PROVOKE GLYCOSURIA IN DOGS AFTER REMOVAL OF THE THYROIDS WHEN AT LEAST TWO PARATHYROIDS ARE LEFT INTACT?

In our attempts to extirpate the thyroids alone we have never been able to convince ourselves that more than one parathyroid attached to each thyroid was uninjured. It is extremely difficult at times to dissect the inner parathyroid from the thyroid, and our efforts in this direction have not been eminently successful. It is certain, however, that at least two parathyroids in this series of experiments remained uninjured. At times one of these was an inner parathyroid, the other the outer parathyroid, and again both were the outer parathyroids. Although no specific statement is contained in the first communication of Eppinger, Falta, and Rudinger<sup>10</sup> as to the number of parathyroids left intact by them, their later paper<sup>11</sup> leads one to infer that none of these glands had been removed. If this is correct, our observations apply to animals retaining a smaller number of parathyroids than the dogs used by these investigators. The results of adrenalin administration to our dogs are given in Table I.

It will be observed, first of all, that in general adrenalin failed to produce glycosuria in these experimental animals when the dose given was less than 1 mgm. per kilo body weight. In one instance, however, Dog A, one half this quantity caused the appearance in the urine of a significant amount of sugar. In quantities of 1 mgm. or more per kilo body weight adrenalin subcutaneously administered invariably induced the excretion of considerable quantities of sugar in the urine of animals deprived of both thyroids but retaining at least two parathyroids.

The doses of adrenalin capable of calling forth glycosuria in our animals were in some instances strictly comparable to those employed by Eppinger, Falta, and Rudinger. In other cases our doses were larger. Special emphasis should be laid upon the negative results

<sup>10</sup> EPPINGER, FALTA, and RUDINGER: *Zeitschrift für klinische Medizin*, 1908, lxvi, p. 1.

<sup>11</sup> EPPINGER, FALTA and RUDINGER: *Ibid.*, 1909, lxvii, p. 1.

TABLE I.

Animal.	Date.	Number of days after thyroidectomy.	Adrenalin chloride per kilo injected.	Urine.				
				Vol.	Reduction test.	Fermentation test.	Osa-zone test.	Dextrose.
Dog A. <sup>1</sup>	Nov. 2, 1908	2	0.5 I <sup>7</sup>	60	P. <sup>7</sup>	P.	P.	1.9
"	" 3, "	"	"	"	Sl. <sup>7</sup>	"	"	Sl.
"	" 24, "	24	0.3 I	"	N.	"	"	0
"	Jan. 21, 1909	81	1.0 S <sup>7</sup>	100	N. <sup>7</sup>	N.	N.	0
"	" 22, "	"	"	97	P.	P.	P.	2.1
"	" 23, "	"	"	85	N.	"	"	0
"	" 24, "	"	"	135	N.	"	"	0
Dog B. <sup>2</sup>	Nov. 27, 1908	24	0.4 I	350	N.	"	"	0
"	Jan. 25, 1909	83	0.6 S	70	N.	"	"	0
"	" 26 "	84	1.6 S.	215	P.	P.	P.	0.86
"	Feb. 1 "	89	1.6 S.	80	P.	P.	P.	"
"	" 15 "	104	0.8 I.	85	P.	P.	P.	9.4
"	" 17 "	"	4.0 S. <sup>8</sup>	"	P.	P.	P.	"
Dog C. <sup>3</sup>	Nov. 30, 1908	23	0.4 I	150	N.	"	"	0
"	Dec. 1, "	"	"	75	N.	"	"	0
"	Jan. 27, 1909	81	1.6 S.	70	P.	P.	P.	1.9
"	" 28 "	"	"	355	P.	P.	P.	4.1
"	" 29 "	"	"	75	P.	P.	P.	"
Dog D. <sup>4</sup>	Feb. 1, "	6	1.0 S.	70	P.	P.	P.	3.6
"	" 2 "	"	"	112	P.	P.	P.	"
"	" 3 "	"	"	70	N.	"	"	0
Rabbit. <sup>5</sup>	" 19 "	18	1.6 S.	130	P.	P.	P.	4.5
Cat. <sup>6</sup>	" 15 "	13	1.4 S.	134	P.	P.	P.	9.9
"	" 16 "	"	"	25	P.	P.	P.	"
"	" 17 "	"	"	"	P.	P.	P.	"
"	" 18 "	"	"	"	Sl.	"	"	0

<sup>1</sup> Dog of 10 kilos in good nutritive condition. Both thyroids removed Oct. 31. At least one parathyroid left intact on each side. Fed a mixed diet.

Aug. 15, 1909, animal still living and has never given any evidences of abnormality due to thyroidectomy.

<sup>2</sup> Both thyroids were removed from well-nourished bitch of 12 kilos Nov. 3. One parathyroid on each side left intact. Mixed diet.

Found dead in pen Feb. 17. Autopsy revealed entire absence of thyroids and the parathyroids were not noticeably hypertrophied.

<sup>3</sup> On Nov. 7 the thyroids were removed from strong, well-nourished bull-dog of 12.5 kilos. At least one parathyroid on each side left intact. Mixed diet.

Aug. 15, 1909, dog still alive. Has never given any evidences of abnormality due to thyroidectomy.

<sup>4</sup> On Jan. 25 both thyroids were removed from a young collie bitch weighing 10 kilos. At least one parathyroid on each side left intact.

<sup>5</sup> Feb. 1 both thyroids were removed from a rabbit of 2.5 kilos. Rapid and uneventful recovery from operation.

<sup>6</sup> Feb. 2. Both thyroids were removed from a cat of 5 kilos. At least two parathyroids were left intact.

No abnormal symptoms of any sort due to thyroidectomy were observed during a period of six weeks.

<sup>7</sup> I. — Intraperitoneally. S. — Subcutaneously. P. — Positive. N. — Negative. Sl. — Slight.

<sup>8</sup> Adrenalin chloride crystals from Parke, Davis & Co. dissolved in water. We are deeply indebted to Dr. E. M. Houghton for his kindness in supplying these crystals.

obtained with the small doses as indicated in Table I. Such observations cannot be considered as showing that these dogs resisted the glycosuria-producing action of adrenalin more strongly than normal animals; for in Table II it is shown that comparable quanti-

TABLE II.

Date.	Number of dog.	Adrenalin chloride per kilo injected.	Sugar in urine.	Remarks.
1908.		mgm.	gm.	
Nov. 27	5	0.45 <sup>1</sup>	0	Black bitch of 11 kilos. Had been well fed.
" 28	..	..	0	
Dec. 9	..	0.2 <sup>1</sup>	0.1	Different sample of adrenalin.
" 18	..	0.2 <sup>2</sup>	0	Same sample of adrenalin that was employed on Dec. 9.
Nov. 30	6	0.3 <sup>1</sup>	0	Well-fed dog of 17 kilos. Different sample of adrenalin.
Dec. 8	7	0.3 <sup>1</sup>	0	Well-fed dog of 15 kilos. Another sample of adrenalin.
		<sup>1</sup> Intraperitoneally.	<sup>2</sup> Painted on pancreas.	

ties of adrenalin also failed to elicit the appearance of sugar in the urine of normal dogs, except in one instance. This case merely emphasizes the variation in this respect which may exist in different specimens of adrenalin, or the variation in susceptibility of the same animal at different times. For illustration 0.45 mgm. adrenalin per kilo introduced intraperitoneally into Dog 5 failed to produce glycosuria, whereas somewhat later one half this quantity of another sample administered in the same manner induced the appearance in the urine of a small quantity of sugar. The same sample when painted upon the pancreas in the same dosage did not produce glycosuria. These observations are in harmony with the statement of Herter and Wakeman,<sup>12</sup> that adrenalin does not always provoke glycosuria, even when this substance is introduced into the organism in considerable quantity.

A particularly interesting feature of these experiments is that no evidences of myxœdema were obvious, even after a period of ten

<sup>12</sup> HERTER and WAKEMAN: *Archiv für pathologische Anatomie*, 1902, clxix, p. 482.

months subsequent to removal of both thyroids and partial parathyroidectomy. When young dogs were subjected to this operation, myxedema was observed by Massaglia.<sup>13</sup> Our own animals were full-grown before removal of these glandular structures.

In Table I is given a single example of the effect of administration of adrenalin upon a rabbit from which the thyroids only were removed. The operation in this animal is very simple, since the thyroids and parathyroids are not in close proximity. The results obtained confirm those of Pick and Pineles,<sup>14</sup> and demonstrate that adrenalin causes the production of glycosuria in the rabbit when the thyroids are removed and the parathyroids are left undisturbed. A single protocol is also inserted of an experiment with a cat. This experiment is comparable to those carried out with dogs. It will be observed that with the cat also thyroidectomy, with at least two parathyroids left uninjured, is without influence upon the glycosuria-producing action of adrenalin.

#### THE ASSIMILATION LIMITS FOR DEXTROSE IN DOGS DEPRIVED OF THE THYROIDS BUT RETAINING AT LEAST TWO PARATHYROIDS.

When the thyroids and all the parathyroids attached are removed from dogs, the ability of the organism to assimilate sugar is decreased. When the thyroids alone are extirpated, this ability is not impaired. If three parathyroids are removed, the assimilation power of the organism for dextrose is decreased. The same effect is produced when one thyroid plus three parathyroids are extirpated. In former experiments<sup>15</sup> it has been demonstrated that normal dogs will completely utilize dextrose subcutaneously introduced in quantities of 5 gm. per kilo body weight. In Table III, Dogs A, B, C, are given the results of experiments designed to test the assimilation limit for dextrose in dogs deprived of their thyroids but retaining at least two parathyroids.

The conclusion is obvious from these data that with two intact parathyroids the sugar-utilizing power of the body is not decreased, even in the complete absence of the thyroids. The protocol of Dog X shows a slightly impaired ability to utilize dextrose subcutaneously

<sup>13</sup> MASSAGLIA: *Archives italiennes de biologie*, 1908, xlix, p. 343.

<sup>14</sup> PICK and PINELES: *Loc. cit.*

<sup>15</sup> SCOTT: *Journal of physiology*, 1902, xxviii, p. 107; UNDERHILL and CLOSSON: *Journal of biological chemistry*, 1906, ii, p. 117.

introduced. A possible explanation of this result is that one thyroid and two parathyroids on one side were removed and one parathyroid on the other, thus leaving one thyroid and one parathyroid in the body. It is probable that the control over sugar utilization is as complete when two parathyroids alone are present as when none have been removed. If this is correct, it is not clear why adrenalin

TABLE III.

UTILIZATION OF DEXTROSE SUBCUTANEOUSLY INTRODUCED AFTER COMPLETE THYROIDECTOMY AND PARTIAL PARATHYROIDECTOMY.

Dog.	Number of days after thyroidectomy.	Subcutaneous injection of dextrose.		Dextrose recovered in urine.	Utilization of dextrose.
		gm.	gm. per kilo.	gm.	per cent.
A	70	272	5	0	100
B	67	288	5	0	100
C	62	330	5	0	100
X	2	309	5	0.68	99.7
X	8	330	5	0.30	99.9

will cause glycosuria in the presence of two parathyroids alone but not when more are present, as has been alleged, and yet two parathyroids, irrespective of the thyroids, are sufficient to maintain life, health, and apparently the normal nutritional rhythm over an extended period of time.

THE URINARY AMMONIA EXCRETION AFTER THYROIDECTOMY AND PARTIAL PARATHYROIDECTOMY.

A previous communication<sup>16</sup> has shown that after thyreoparathyroidectomy the most significant influence observed upon nitrogenous metabolism in dogs, as indicated by the kidney excretion, was an increased output of ammonia attended by a distinct tendency toward an alkaline reaction of the urine. Since, subsequent to the removal of the thyroids and parathyroids, food is no longer retained, the observations just cited were obtained upon animals in a fasting condition. It has been demonstrated previously by Underhill and

<sup>16</sup> UNDERHILL and SAIKI: *Loc. cit.*

Kleiner<sup>17</sup> that inanition of the duration which obtained in our former experiments does not lead to an increase of ammonia<sup>4</sup> at all comparable to that observed after thyreoparathyroidectomy.

TABLE IV.  
AMMONIA CONTENT OF URINE AFTER COMPLETE THYROIDECTOMY AND  
PARTIAL PARATHYROIDECTOMY.

Dog A.							
Date 1909	Vol.	Specific gravity.	Reaction to litmus.	Total nitrogen.	Ammonia nitrogen.	Ammonia nitrogen.	Remarks.
Mar	c.c.			gm.	gm.	per cent.	
13	60	1.050	Acid	3.65	0.104	2.8	No food was given throughout this period of observation.
14	62	....	....	2.80	0.158	5.6	
15	55	....	....	2.04	0.144	7.0	
17	135	1.051	Acid	5.55	0.336	6.0	
19	72	....	....	3.20	0.150	4.6	
21	73	....	....	3.34	0.205	6.0	
23	67	....	....	3.00	0.189	6.2	
24	31	....	....	1.58	0.104	6.5	
25	55	....	....	2.77	0.156	5.6	
Dog C.							
Feb							No food was given throughout this period of observation.
23	70	1.050	Acid	3.24	0.095	2.9	
24	67	1.051	"	2.60	0.140	5.3	
25	38	....	....	1.81	0.079	4.3	
26	53	1.062	Acid	2.38	0.103	4.3	
28	72	....	....	3.63	0.250	6.8	
Mar.							
1	52	1.060	Acid	2.40	0.130	5.4	
2	36	....	....	1.75	0.097	5.5	
3	33	....	....	1.22	0.059	4.8	
5	80	1.056	Acid	3.94	0.139	3.5	

<sup>17</sup> UNDERHILL and KLEINER: *Journal of biological chemistry*, 1908, iv, p. 165.

The present experiments have been arranged to determine whether thyroidectomy in dogs with at least two parathyroids intact would influence the output of ammonia in the urine. To have other conditions strictly comparable with those obtaining in the experiments with thyreoparathyroidectomized dogs food was withheld during the entire period of observation. The subjects were Dogs A and C previously employed in other experiments. Since both animals were male dogs, no attempts were made to divide the urine secreted into exact twenty-four-hour specimens. Only the percentage composition is of significance here. Too much reliance should not be placed upon percentages alone; yet, since the differences in this direction are so slight, they undoubtedly give a true picture in this instance. The results<sup>18</sup> given in detail in Table IV clearly demonstrate that the ammonia excretion by the kidney is not significantly altered in animals deprived of both thyroids but retaining two parathyroids. The tendency toward alkalinity of the urine noted in thyreoparathyroidectomy failed to evince itself in these later experiments.

#### SUMMARY.

When thyroidectomy and partial parathyroidectomy have been performed upon dogs, the presence of at least two intact parathyroids is sufficient to maintain life, health, and apparently normal control of the nutritional processes of the body for a long period of time.

Contrary to the results obtained with thyreoparathyroidectomy, the above operation does not result in a lowering of the assimilation limit for dextrose introduced subcutaneously; nor could any evidence be obtained that this operation gives rise to an increase in urinary ammonia excretion similar to that resulting from complete thyreoparathyroidectomy.

After an operation whereby one thyroid and three parathyroids were removed, there was observed a measurable diminution in the sugar-assimilative power of the organism.

Adrenalin chloride administered subcutaneously in doses of 1 mgm. or more per kilo body weight invariably causes a significant glycosuria in dogs deprived of both thyroids but retaining at least

<sup>18</sup> Ammonia was estimated by Folin's method. *This journal*, 1905, xiii, p. 45.

two parathyroids. These observations are not in harmony with those reported by Eppinger, Falta, and Rudinger. •

Unlike the experience of Massaglia with young dogs, no evidences of myxœdema were observed with our full-grown animals (two dogs) even ten months subsequent to removal of the thyroids and partial parathyroidectomy.



THE INTEGUMENTARY NERVES OF FISHES AS  
PHOTORECEPTORS AND THEIR SIGNIFICANCE  
FOR THE ORIGIN OF THE VERTEBRATE EYES.

BY G. H. PARKER.

[*Professor of Zoölogy, Harvard University.*]

IT is now well established that the integumentary nerves of many amphibians are sensitive to light, but among the most primitive vertebrates, the fishes, this subject has scarcely been investigated. According to the observations of Eigenmann (:00), the integumentary nerves of the blind fishes, *Chologaster* and *Amblyopsis*, are sensitive to light, — a conclusion confirmed, so far as *Amblyopsis* is concerned, by the recent work of Payne (:07), and according to my own studies (Parker, :05), the same is true of ammocætes. Since so primitive a fish as ammocætes exhibited this peculiarity in a very marked degree, I was led to expect it among fishes generally. I was therefore greatly surprised to get no evidence for the sensitiveness of the skin of amphioxus to light (Parker, :08<sup>a</sup>); hence I resolved to test other fishes in this respect. Opportunity to make some preliminary tests occurred while I was at the Laboratory of the United States Bureau of Fisheries at Woods Hole, Massachusetts, during the summer of 1908, and these came out in such an unexpected manner that they seem worthy of record.

The following nine species of fishes were tested: dogfish (*Mustelus canis*), eel (*Anguilla chryspa*), killifish (*Fundulus heteroclitus*), scup (*Stenotomus chrysops*), cunner (*Tautoglabrus adspersus*), tautog (*Tautoga onitis*), puffer (*Chilomycterus schoepfi*), toadfish (*Opsanus tau*), and tomcod (*Microgadus tomcod*). In preparation for the tests, several individuals of each species were etherized and their optic nerves were cut; these fishes were then kept for about

a week in a large aquarium till they had recovered from the operation and had adjusted themselves to the new conditions. They were then subjected to stimulation on the head, trunk, and tail by concentrated light from an arc lamp and from the sun.

The arc lamp employed in these experiments was such as is used on shipboard for a search light. Its beams were concentrated by a large biconvex lens whose diameter was about 13 centimetres and whose principal focus was 10 centimetres. The light that was concentrated by the lens was made to pass through a water screen 2 centimetres thick before it entered the aquarium in which the fish was retained. The fishes were placed individually in this aquarium, and after they had become quiet, the beam of light was thrown upon the particular parts of their bodies to be tested. Notwithstanding the prolonged application of the stimulus, not a single unequivocal response was obtained from them, though from time to time they swam about as they would under ordinary circumstances. I therefore suspected that the stimulus was insufficient and turned to stronger light.

In using sunlight, the aquarium, water screen, and lens were transferred to an open spot where they were set up in the shade, and by means of a large mirror a beam of reflected sunlight was thrown through them in the same way as when the arc light was used. Although the concentrated sunlight was extremely intense, repeated trials failed to elicit from the fishes any reactions that gave evidence that they were stimulated. As the conditions of the experiments were essentially the same as those in which light reactions were obtained from ammocetes, I was forced to conclude that the integumentary nerves of the nine species of fishes tested were not photoreceptors. This is in support of the earlier observations by Long (Parker, 1905, p. 413) to the effect that the integumentary nerves of *Fundulus* are not sensitive to light.

In discussing the light reactions of ammocetes, I have already called attention to the fact that among vertebrates certain fishes, amphibians, and reptiles possess photoreceptors in their skin; no cases of a similar kind are known among birds or mammals. The additional instances that have now been brought to light are especially significant in reference to their distribution. Of the water-inhabiting vertebrates thus far examined, all that have been shown to possess photoreceptors in their integuments (ammocetes, *Anilyopsis*, and *Chologaster* among fishes, and numerous amphibians)

are fresh water inhabitants, whereas those whose integumentary sense organs are not stimulated by light (amphioxus, and the nine species of fishes enumerated in this paper) are all marine. This distribution suggests the possibility that fresh water is a favorable environment for the development of photoreceptors in the vertebrate skin and that salt water is inimical to this process. The conditions may be just the reverse of those pointed out by Murray (:08) for animal phosphorescence, which is common in the sea but unknown in fresh water.

The bearing of these facts on the problem of the origin of the vertebrate eyes is not far to seek. In a recent paper (Parker, :08<sup>b</sup>) I have pointed out that the more usually accepted theory as to the origin of these organs has two forms. According to the first of these (Lankester, '80; Boveri, :04), the retina is supposed to arise in the central nervous organs and make its way by growth out to the periphery of the animal. From this standpoint the vertebrate retina is supposed to be unlike most other sense organs in that it is believed to have arisen from deep-seated, not from superficial, ectoderm. According to the second form of this theory (Balfour, '81; von Kennel, '91; Jelgersma, :06), the retina is supposed to have originated in the superficial ectoderm, as it usually does in most invertebrates, and to have been infolded with the central nervous system, from which it secondarily grew out to the surface again. The presence of photoreceptors in the skin of amphibians and of ammocetes was originally taken by me (Parker, :03, :05) to favor the second form of this theory, but the subsequent discovery (Parker, :08<sup>a</sup>) that in amphioxus there is no reason to believe that the integument is sensitive to light and that the photoreceptors of this animal are limited to its central nervous organs, led me to accept the first form of this theory. The results of the present inquiry confirm the conclusion arrived at from the study of amphioxus, for, if no marine vertebrate has photoreceptors in its integument because of the unfavorableness of a marine environment for such organs, it is highly improbable that the ancestors of the vertebrates, which were also surely marine, could have possessed integumentary organs such as are supposed by the second form of the theory to have been the forerunners of the vertebrate eyes. I therefore believe that the eyes of vertebrates have had a central rather than a peripheral origin, and from this standpoint the photore-

ceptiveness of the skin of certain fishes, amphibians, and reptiles must be looked upon as a secondarily acquired peculiarity.

## BIBLIOGRAPHY.

- BALFOUR, F. M.  
 '81. A Treatise on Comparative Embryology. Vol. 2. London, 8vo, xi + 655 + xxii pp.
- BOVERI, T.  
 :04. Ueber die phylogenetische Bedeutung der Sehorgane des Amphioxus. Zool. Jahrb., Suppl. 7, pp. 409-428.
- EIGENMANN, C. H.  
 :00. The Blind-fishes. Biol. Lect. Mar. Biol. Lab., Woods Holl, 1899, pp. 113-126.
- JELGERSMA, G.  
 :06. Der Ursprung des Wirbeltierauges. Morph. Jahrb., Bd. 35, pp. 377-394, Taf. 9.
- KENNEL, J. VON.  
 '91. Die Ableitung der Vertebratenaugen von den Augen der Anneliden. Dorpat, 4<sup>o</sup>, 27 pp., 1 Taf.
- LANKESTER, E. R.  
 '80. Degeneration. London, 8vo, 75 pp.
- MURRAY, J.  
 :08. The Distribution of Organisms in the Hydrosphere as affected by varying chemical and physical Conditions. Rev. ges. Hydrobiol., Bd. 1, pp. 10-17.
- PARKER, G. H.  
 :03. The Skin and the Eyes as Receptive Organs in the Reactions of Frogs to Light. Amer. Jour. Physiol., Vol. 10, pp. 28-36.
- PARKER, G. H.  
 :05. The Stimulation of the Integumentary Nerves of Fishes by Light. Amer. Jour. Physiol., Vol. 14, pp. 413-420.
- PARKER, G. H.  
 :08'. The Sensory Reactions of Amphioxus. Proc. Amer. Acad. Arts Sci., Vol. 43, pp. 415-455.
- PARKER, G. H.  
 :08". The Origin of the Lateral Eyes of Vertebrates. Amer. Nat., Vol. 42, pp. 601-609.
- PARKER, G. H.  
 :09. The Receptiveness of the Vertebrate Skin for Light and the Origin of the Vertebrate Eye. Science, n. ser., Vol. 29, p. 432.
- PAYNE, F.  
 :07. The Reactions of the Blind Fish, *Amblyopsis spelæus*, to Light. Biol. Bull., Vol. 13, pp. 317-323.

# THE DESTRUCTIVE EFFECT OF SHAKING UPON THE PROTEOLYTIC FERMENTS.

BY A. O. SHAKLEE AND S. J. MELTZER.

[From the Department of Physiology and Pharmacology of the Rockefeller Institute for Medical Research.]

## INTRODUCTION.

**I**N brief preliminary communications<sup>1</sup> we have already stated that shaking exerts a destructive influence upon the proteolytic enzymes. Since these reports were made the experiments were gone over critically again and were also extended. We intend to give in the present paper in the first place a detailed account of the methods which were employed and the facts which were found in the course of this investigation. We wish, however, to deal in this paper with the subject of shaking from a wider, a more general point of view. In the chemical studies of the action of ferments, a field which in recent years is being so extensively cultivated, the shaking of digestive mixtures for many hours in succession belongs to the routine procedures. If shaking produces such a profound effect upon enzymes as was found in our experiments, it certainly must be a factor in obtaining the results of these chemical studies. Nevertheless it is only very recently that some physiological chemists came out with observations of this kind. We shall discuss later these observations in connection with our own experience. We wish to say here, however, that it was not an accidental stumbling upon such a fact that aroused our attention. Our starting-point was the accumulated evidence regarding the effect of shaking upon corpuscular elements of microscopical dimensions. One of us (Meltzer) has been interested in this latter problem for the last twenty-five years. In a paper by this author, published in 1894, the subject of the "Importance of vibration to living matter"

<sup>1</sup> SHAKLEE and MELTZER: *Zentralblatt für Physiologie*, 1900, xxiii, p. 3; *Proceedings of the Society for Experimental Biology and Medicine*, vi, pp. 48 and 103.

was discussed at some length. Based upon evidence derived from experiments of his own and upon an analysis of the data collected from the literature, the writer arrived at the conclusion that vibration is an important factor in the processes of life. It was on the basis of this that we began to study the problem of the influence of shaking upon enzymes. Since the publication of the mentioned paper other interesting investigations appeared on the subject of shaking upon corpuscular living bodies. The results obtained in these new studies are in harmony with the previously expressed views.

In discussing later the nature of the processes which take place in the inactivation or destruction of ferments by shaking we shall try to gain a point of view from which we could interpret the action of shaking in an identical manner for the enzymes and the corpuscular bodies. It is therefore desirable to have here also an account of what is known of the action of shaking upon these latter elements. We shall therefore preface the report upon our experiments by a brief review of the literature upon the subject of the influence of shaking upon corpuscular elements.

#### THE INFLUENCE OF SHAKING UPON LIVING BODIES OF MICROSCOPICAL DIMENSIONS.

Horvath<sup>2</sup> — 1878 — was the first to study the influence of shaking upon microorganisms; he found that by a certain method of shaking bacteria their growth may be retarded, or they may even become completely destroyed. Although Naegeli<sup>3</sup> considered this statement to be of considerable importance to biology, practically no serious study of that subject followed Horvath's investigation. Among the dozen or more writers whom Meltzer could quote in 1894 on the subject of shaking, there seemed to be a complete disagreement regarding the effect of shaking. Some stated that it is destructive, some that it is without any effect, and some even maintained that shaking exerts a beneficial effect. The trouble with these investigations was that in each case another organism was tested, and by another method. Moreover, none of the investigators used the method which was employed by Horvath. The

<sup>2</sup> HORVATH: *Archiv für die gesammte Physiologie*, 1878, xvii, p. 125.

<sup>3</sup> NAEGELI: *Theorie der Gährung*, München, 1879.

objects which were tested in these investigations were mostly mixtures of bacteria; in a few instances the bacteria were definite species, and in two instances definite species of yeasts were shaken.

Independent of the experiments of Horvath, Meltzer and Welch<sup>4</sup> — 1884 — studied the influence of shaking upon the red cells of bullock's blood. Accidentally they used a method of shaking similar to that which was employed by Horvath. In addition to that, Meltzer and Welch increased the effect of shaking by adding granular substances to the dilute blood. It was found that the red corpuscles became completely destroyed by shaking. Of the particulars only a few points should be mentioned here. The destruction was the more rapid, the heavier the added granular substances and the finer they were. No fragments of the corpuscles could be observed; the red cells were converted into "dust."

In the investigations reported by Meltzer in his paper of 1894<sup>5</sup> the effect of shaking was studied upon well-defined bacteria, and the results were studied by the usual bacteriological methods. Glass beads were added to the bacterial suspensions; otherwise the method was the same as the one employed for the red blood corpuscles. The results differed now greatly with the species of bacteria, with the duration of the shaking and with the energy with which the shaking was carried out. There were bacteria for which the average moderate degree of shaking was destructive; others for which the very same shaking was beneficial. One species was found which practically was not growing at all without a certain degree of shaking; it grew best at a higher degree of shaking, and only at a very strong degree of shaking it became destroyed. The destruction of bacteria consisted, like that of the red blood corpuscles, in the conversion into "dust"; the shaking never led to a breaking down into fragments.

On the basis of his experiments and of those of others Meltzer has put forward the supposition that shaking or vibration is one of the physiological factors of life; a minimum of shaking is indispensable to the living organism; there is an optimum degree at which the organism thrives best and there is a maximum degree of shaking beyond which it is destructive to the life of the organism. Minimum, optimum, and maximum, however, vary with each

<sup>4</sup> MELTZER and WELCH: *Journal of physiology*, 1884, v, p. 255.

<sup>5</sup> MELTZER: *Zeitschrift für Biologie*, 1894, xxx, p. 464.

species of organism. Some algae grow only under waterfalls and some bacteria become destroyed merely when their cultures are carried from one room to another.

In 1900 Meltzer<sup>6</sup> studied again the influence of shaking upon red blood corpuscles. This time blood cells of various animals were shaken, and in many experiments glass beads were added. Here are some of the main results: The simple act of defibrination shortens already the life of the corpuscles. Shaking with glass beads is capable of completely destroying the corpuscles of all animals. The time required for destruction differs with the species of animals. For the blood cells of some animals (guinea pigs) a certain small degree of shaking proved to be beneficial, — it prolonged their life. Again, as in the previous experiments with Welch, the corpuscles broke down to "dust," never into fragments. When the shaking was continued, the dust became beaten together to little clumps or to ragged threads, which grew in size with the continuation of the shaking. Hæmoglobin crystals did not break down by shaking. Shaking therefore appeared to affect only *organized*, so to say, living minute bodies, converting them into "dust"; it does not break down crystals or unorganized minute organic masses.

Of special interest are the observations made on the influence of shaking upon certain echinoderm eggs. Morgan<sup>7</sup> observed that shaking hastens the maturation of starfish eggs, it accelerates the extrusion of the polar bodies and causes the disappearance of the nuclear membranes. Eggs which have been shaken before fertilization develop in much larger numbers than eggs which were not shaken. Mathews<sup>8</sup> made the further interesting observation that starfish eggs might develop without fertilization — artificial parthenogenesis — by shaking them (after maturation) in a test tube or by squirting them from a syringe. Too strong shaking of the eggs causes a dissolution of the whole egg. Similar observations were made by Fischer<sup>9</sup> on the eggs of amphitrites. The amount of agitation necessary to bring about a parthenogenetic development of the eggs of susceptible species varies with the individuals of the same species. On the other hand it was established by

<sup>6</sup> MELTZER: Johns Hopkins Hospital reports, 1900, ix, p. 135 (Contributions to the science of medicine, dedicated to William Henry Welch).

<sup>7</sup> MORGAN: Anatomischer Anzeiger, 1893, p. 141.

<sup>8</sup> MATHEWS: This journal, 1902, vi, p. 142.

<sup>9</sup> FISCHER: This journal, 1902, vii, p. 303.



Mathews and by Loeb that eggs of arbacia cannot be made to develop parthenogenetically by any degree of shaking. Mathews and Whitcher,<sup>10</sup> as well as Meltzer,<sup>11</sup> found that strong agitation may cause a destruction of the unfertilized as well as of the fertilized arbacia eggs. They also stated that shaking may hasten the course of development of the fertilized eggs. This, however, was not confirmed by Whitney.<sup>12</sup> The above-mentioned authors have also found that fertilized eggs of arbacia are much more resistant to the destructive effect of shaking than the unfertilized eggs. According to Meltzer the unfertilized eggs are converted by violent shaking into "dust-like debris," while the fertilized eggs show only disorganized eggs and coarse fragments.

We may point out that the interesting experiments upon echinoderm eggs bring out again the fact that shaking may be harmful as well as favorable, depending upon the species of the animal and to a degree even upon the individual from which the eggs were obtained, and also according to the degree of shaking which was employed.

From this brief review we learn that in the past thirty years the physiological influence of shaking was the subject of many investigations. The subjects of these experiments may be roughly divided into three groups, — bacteria including yeast, echinoderm eggs, and red blood corpuscles. Bacteria and eggs are cells, living organisms.

Red blood corpuscles differ from the other cells essentially by the lack of power of reproduction. Nevertheless they are usually considered as living cells. They perform a vital function, they are subject to metabolic processes and they die. Red blood corpuscles are certainly organized units of living matter.

We may point out here again that in the second series of experiments of Meltzer upon red blood corpuscles it was clearly demonstrated that clumps of organic matter are affected by vigorous shaking in an entirely different manner from organized living cells (red blood corpuscles).

From the various investigations we have learned that organized living bodies of microscopical size are profoundly affected by shaking. With some degree of shaking and with some species of these organized bodies the influence may be a favorable one: bacterial

<sup>10</sup> MATHEWS and WHITCHER: This journal, 1903, viii, p. 300.

<sup>11</sup> MELTZER: This journal, 1903, ix, p. 245.

<sup>12</sup> WHITNEY: Journal of experimental zoölogy, 1906, iii, p. 41.

cultures may grow more rapidly, blood cells may live longer, and some echinoderm eggs may develop even parthenogenetically. Vigorous shaking causes a destruction of these organisms; but the destruction again is specific for the organized living bodies; they do not break down into fragments or coalesce into formless masses; red blood corpuscles and bacteria are "converted into dust" and some echinoderm eggs undergo a complete "dissolution."

These facts entitle us to look upon shaking as one of the influential conditions of life; it is with shaking as it is with heat, some degrees are indispensable, others present an optimum, and still others act as a destructive maximum, and these degrees vary with the species of the living organisms.

As to the nature of the mechanism through which shaking produces such effects as are mentioned above, we may restate here briefly the theory offered by Meltzer in the above-mentioned paper on the "Importance of vibration to living matter." In living organized matter the physical molecules are, according to this theory, collected into groups, *physiological units* (in contradistinction to physical units), which are completely separated from one another by a system of connected spaces carrying liquid. These units are in continued vibration, which keeps the liquid in the drainage system in continual motion. By this motion oxygen and other necessities are carried to, and waste products are removed from, these units by the way of the drainage system. In cells and in other seemingly homogeneous living organized matter the metabolic exchange is carried on, perhaps not by simple diffusion, but *by a circulatory system in which the vibrations of the physiological units replace the pumping action of the heart and the system of spaces represents the vessels*. The physiological units are set into motion by vibrations received from outside. Therefore a certain degree of shaking or vibration is indispensable for all living matter. It is obvious that some degree of shaking may be an optimum, while a violent shaking may disrupt all living matter, converting it into the dust of the living units. In higher animals the shocks coming from the heart beats, the respiration, etc., might be sufficient to provide the most distant cells with the necessary vibration. Organisms which do not have such an aid within themselves receive these vibrations from outside and thrive only where they can be provided with this factor of life. It is easily comprehensible that according to the grouping of the physiological units and their relation to their in-

ternal system of drainage the various organisms might differ greatly with regard to the degree of vibration they require — some algae get what they need only under a waterfall.

It was on the basis of these facts and views that we approached the question: Can shaking influence ferments? We do not know the "substance" of ferments, we know these only by their action. We are willing to admit that ferments are not living organisms. But they are invariably associated with them, exert a great immediate influence upon life phenomena, are activated and destroyed by most factors which favor and destroy life. May we not assume that the carriers of ferments, while deprived of many characteristics of living cells, may show nevertheless that organization of living matter which was assumed above for living organisms, namely, that also the structure of the carriers of enzymes consists in vibrating physiological units separated from one another by a system of liquid-carrying spaces? These were the considerations which started us upon the present investigation, the details of which we are now going to report.

#### OUR EXPERIMENTS.

**Methods of shaking.** — On the basis of the foregoing statement we may expect that the vibrations within each class of living matter are somewhat specific in their nature, and that therefore a shaking which should be effective ought to be of a specific kind, capable in each case to produce adequate vibrations. This holds good especially for vibrations which are capable of producing favorable results. For the destructive effects we may perhaps assume that the shaking need not be of a very specific kind. However, from the very first experience in that line, from the experiments of Horvath, we learned that even for the purpose of destruction the shaking must be carried out in a definite way. Horvath obtained no results when he attempted to shake the mixtures of bacteria by a rotating apparatus or by a swinging pendulum. His positive results were obtained only when the bacteria were shaken by a machine which shook the bottles horizontally in the direction of their long axis. We have already stated that few investigators have taken the precaution to use Horvath's method in repeating his experiments. Some who have seen no effects of shaking were using rotating machines, or the bottles within a machine were struck so and so many times a minute (B. Schmidt, Whitney, and others). In the second series of experiments by Meltzer with red blood corpuscles it was established that there is a striking difference in the effect whether

the bottles were shaken in the direction of their long or their transverse axis.

In the present investigation the shaking was carried out in the manner used by Horvath and employed also by Meltzer in his various investigations on the effects of shaking. Long, round bottles were employed which had a capacity of 115 c.c., a length (neck not included) of 14 cm. and a transverse diameter of 3.6 cm., and were charged usually with 10 c.c. of the solutions to be shaken. The bottles were securely placed in the carriage of a shaking machine, the movements of which were in the direction of the long axis of the bottles. The length of the excursions was about 8 cm. The rate of the movements in one direction varied between 100 and 150 times in a minute. Two shaking machines were employed; one is kept in the basement of the building where the temperature during the period of experimentation varied between 13° and 23° C.; the other is kept in a thermostat in which the temperature is kept approximately at 33° C. Controls were kept in the neighborhood of each machine under the same conditions except for the shaking.

The effect of shaking was studied in this series as stated at the outset upon the three proteolytic enzymes: pepsin, trypsin, and renin. Of these pepsin was studied first and more extensively than the others.

**Newer methods of testing for pepsin.**—The activity of this ferment was measured by three methods which were introduced very recently especially for clinical purposes: the Jacoby-Solmes<sup>13</sup> ricin method, the edestin method of Fuld,<sup>14</sup> and the casein method of Gross.<sup>15</sup> The principle of the Jacoby method consists in the fact that ricin (impure) dissolved in a neutral salt is precipitated by HCl. The heavy milky precipitate is digested by pepsin. The Fuld method rests upon the fact that neutral salts bring out a precipitate in a solution of edestin (edestin in HCl), but not in that of its digestion products. The method of Gross is based upon a similar principle: acetic acid causes a precipitation in a solution of casein, but not in that of caseoses.

The particulars of these methods, as they are described in the medical literature, were worked out chiefly with an eye upon their use for clinical purposes. In this investigation details of the quantitative tests were slightly modified, especially in the methods of Fuld and of Gross. At the beginning of the research the ricin method of Jacoby was employed exclusively. In the further course, however, the methods of Gross and of

<sup>13</sup> (JACOBY-)SOLMS: *Zeitschrift für klinische Medizin*, 1907, lxiv, p. 159.

<sup>14</sup> FULD: after Wolff and Tomaszewsky, *Berliner klinische Wochenschrift*, 1907, p. 1051.

<sup>15</sup> GROSS: *Berliner klinische Wochenschrift*, 1908, p. 643.

Fuld were also employed, especially the latter, which offers some advantages over the other methods.

The particulars of the ricin method, as it was employed here, were as follows: Into each of a series of test tubes 0.05 c.c. of a pepsin solution was carefully measured from a pipette graduated to hundredths. Some of the tubes received shaken solutions, others received the corresponding controls. Then into each tube was run 0.5 c.c. of a solution of HCl (0.5 per cent). Finally 2 c.c. of a ricin solution (1 per cent ricin in a 5 per cent aqueous solution of NaCl) were quickly run into each tube from a 10 c.c. pipette. One or two tubes were prepared without pepsin for the purposes of comparison later in estimating the amount of digestion. The tubes were now corked and the contents thoroughly mixed by inverting the tubes a sufficient number of times. All tubes were then placed in a thermostat, kept at 37° to 38° C., and examined about every twenty or thirty minutes; deductions were derived from a comparison of the amount of the precipitate at each examination as well as from a comparison of the times (Schütze's law) when complete digestion took place.

The Fuld method was used in a modified form, as appears from the following description: To find the amount of pepsin destroyed by shaking, we determined how much of the shaken pepsin solution was necessary to digest 2 c.c. of a 0.1 per cent edestin solution,<sup>10</sup> in the same time as a given quantity of the unshaken solution (control). It was thought desirable to make the digestion period about two hours in order to reduce the error due to the digestion that would take place in the first tubes of the series between the time when the edestin solution was added to them, and when it was added to the succeeding tubes. It was found that if the 1 per cent solution of pepsin which was the one we usually used were diluted 25 times, 0.5 c.c. of this dilution would about digest 2 c.c. of the edestin solution in two hours; hence 0.5 c.c. of the control solution was used as the standard, and the shaken solution was so diluted, when possible, as to require about 0.5 c.c. of the dilution to digest 2 c.c. of edestin solution in the same time. The test was carried out in the following way: The standard quantity of pepsin was run into each of the first two of a series of test tubes, from a pipette graduated to hundredths of 1 c.c., then increasing quantities of the diluted shaken solution were run into the succeeding tubes. Next the volumes in all the tubes were made the same by adding dilute HCl of the same strength as that employed in making the pepsin solutions and their dilutions. Finally 2 c.c. of a 0.1 per cent solution of edestin in a 0.1 per cent aqueous solution of HCl was rapidly run from a 10 c.c. pipette into each tube. The tubes were then corked and the contents thoroughly

<sup>10</sup> For the edestin we have to thank Dr. P. A. Levene.

mixed. They were kept in the thermostat at 40° C. for about two hours. After removal from the thermostat the tubes were placed in the refrigerator to cool, and after they had cooled, a saturated solution of NaCl was carefully run down the sides of the tubes, until it formed a considerable layer underneath the digestion mixture. The tubes were then allowed to stand for fifteen to twenty minutes. At the end of this time each *standard* tube had a faint white ring between the salt solution and digestion mixture, while the *comparison* tubes showed a gradation of rings ranging in density from lighter than the standard to heavier. The comparison tube which had a ring like the rings of the standard tubes was regarded as having the same quantity of pepsin in it as the standard quantity, and the difference between this quantity and the amount it contained before shaking was regarded as the quantity of pepsin destroyed by the shaking; *e. g.*, if the quantity of shaken solution in the comparison tube represented 0.10 gm. pepsin in the solution before shaking, and the standard quantity of pepsin were 0.02 gm., it was concluded that 80 per cent of the pepsin activity had been destroyed by the shaking. (The results seem to be most accurate when the rings are examined in a suitable light against a suitable background. In most tests the rings were illuminated by direct sunlight and examined against a dark background.)

The Gross method was modified in much the same way as the Fuld method. After the tubes had been charged with the pepsin solutions and the volumes made equal as there described, 2 c.c. of a 0.1 per cent solution of casein in dilute HCl was quickly run into each tube from a pipette, and the contents mixed and digested as with the Fuld method. After digestion the end point was found by using a saturated solution of sodium chloride in a 5 per cent aqueous solution of acetic acid, in the manner in which we used the saturated aqueous solution of NaCl in the Fuld method. The amount of pepsin destroyed by shaking was calculated in the way there described.

In most experiments commercial pepsin (Fairchild) was used in 1 per cent solution; in only a small number of experiments the solutions were of 0.1 per cent or of other strengths. Again in most experiments pepsin was dissolved in dilute HCl (0.25 per cent); in some experiments only 0.1 per cent or other concentrations of HCl were used; in some no HCl was used.

Other variations of the method will be mentioned when describing the results.

#### THE INFLUENCE OF SHAKING UPON PEPSIN.

It may be stated at the outset that every one of the experiments brought definite evidence that shaking, as we employed it, is

capable of exerting a destructive influence upon the activity of pepsin. The following experiment will illustrate this statement:

*Experiment 1.* — Five bottles, each were charged with 10 c.c. of a solution of pepsin (1 per cent + 0.5 per cent HCl). The space above the solution in bottles Nos. 76 and 81 was filled with hydrogen, in bottles Nos. 75, 79, and 80 the space was filled with air. Bottles Nos. 75 and 76 were shaken continually for eight hours in the thermostat at 33.7° C. at the rate of 104 per minute. Bottles Nos. 79, 80, and 81 were kept also in thermostat, but not shaken (controls). Five test tubes were then prepared as follows: To two of the test tubes 0.05 c.c. of the shaken pepsin (one with air and one with H), and to each of the other 3 test tubes 0.05 of the unshaken pepsin was added. Then 0.5 c.c. of HCl 0.5 per cent was run into each tube, and finally 2 c.c. of ricin solution. All test tubes were now incubated at 38° C. for digestion. The result is shown in Table I.

The result is unmistakable. Whereas the unshaken pepsin was sufficient in quantity and quality to digest the heavy precipitate of the ricin within one hour, the same quantity of the same pepsin, but shaken for eight hours at 33.7° C., did not affect the precipitate even after keeping the tubes for four days at a digestion temperature.

In one of the shaken tubes in these experiments the space above the pepsin solution was filled up with hydrogen. This was done to demonstrate that the destruction was not due to the intimate mixing of the pepsin solution with the oxygen of the air, perhaps a sort of detrimental oxidation. In a number of experiments the space above the pepsin solution was filled with hydrogen or carbonic acid gas. There was no difference in the result whether that space was filled with air or with the mentioned gases. We shall cite an experiment in which one of the bottles was filled with CO<sub>2</sub>.

*Experiment 2.* — Four bottles each received 15 c.c. pepsin solution prepared as stated above. The spaces above the solution in bottles 10 and 12 contained air, in bottles Nos. 11 and 13 CO<sub>2</sub> gas. Bottles 10 and 11 were shaken one hour in the thermostat at 34° C.; bottles 12 and 13 were kept also in the thermostat, but unshaken (control). Four test tubes were then prepared as follows: Into each tube was run 0.05 c.c. of pepsin solution (one charge from each bottle), then HCl and ricin as in the previous experiment. The 4 test tubes were then incubated in the thermostat (38° C.) for digestion. Table II. shows the result.

TABLE I  
RICIN TEST FOR PEPSIN

Incubation time began at 10 A. M., Oct. 12, 1908.	QUANTITY DIGESTED.				
	Shaken 8 hours.		Controls.		
	No. 75.	No. 76.	No. 79.	No. 80.	No. 81.
10.32 A. M., Oct. 12, 1908 . . .	0	0	per cent. 90	per cent. 85	per cent. 85
11.00 A. M., Oct. 12, 1908 . . .	0	0	Complete	Complete	Complete
10.25 P. M., Oct. 12, 1908 . . .	0	0	.....	.....	.....
8.24 A. M. Oct. 13, 1908 . . .	0	0	.....	.....	.....
8.00 A. M., Oct. 13, 1908 . . .	0	0	.....	.....	.....
8.00 A. M., Oct. 14, 1908 . . .	0	0	.....	.....	.....
5.45 P. M., Oct. 14, 1908 . . .	0	0	.....	.....	.....
7.45 A. M., Oct. 15, 1908 . . .	0	0	.....	.....	.....
7.45 P. M., Oct. 15, 1908 . . .	0	0	.....	.....	.....
8.00 A. M., Oct. 16, 1908 . . .	0	0	.....	.....	.....

This experiment shows in the first place that shaking even for one hour (at 34° C.) affects greatly the activity of the pepsin. While the unshaken pepsin digested nearly all of the precipitate in thirty-five minutes, it took the shaken pepsin about twenty-four hours to digest as much as the unshaken ferment digested in half an hour. The experiment shows further that in the presence of CO<sub>2</sub> (instead of air), the destruction of the pepsin goes on with at least the same effectiveness as in air. In fact, in the few experiments in which the pepsin was shaken for short periods in an atmosphere of CO<sub>2</sub> the destruction seemed to be even more advanced than when shaken for similar periods in an atmosphere of air. At any rate, it is quite evident that the destruction of the pepsin is not due to some process of oxidation.

**Influence of duration of shaking.**— From the difference in the results of the foregoing two experiments the fact can be derived that the degree of the destruction grows with the length of the



period of shaking. While in the first experiment, in the tube containing pepsin which was shaken for eight hours, no sign of digestion of the precipitate could be detected even after a continuous incubation in the thermostat for four days, we notice in the second experiment that in the tube containing pepsin which was shaken

TABLE II.  
RICIN TEST FOR PEPSIN.

Incubation time began at 9.00 A. M., Sept. 29, 1908.	QUANTITY OF PRECIPITATE DIGESTED.			
	Pepsin shaken one hour at 34°.		Controls.	
	No. 10 Air.	No. 11 CO <sub>2</sub> .	No. 12 Air.	No. 13 CO <sub>2</sub> .
9.35 A. M., Sept. 29 . . . . .	per cent. 0	per cent. 0	per cent 95	per cent. 95
11.05 A. M., Sept. 29 . . . . .	50	50	Complete	Complete
3.50 P. M., Sept. 29 . . . . .	70	60	.....	.....
9.20 A. M., Sept. 30 . . . . .	90	70	.....	.....
12.20 P. M., Oct. 1 . . . . .	Complete	90	.....	.....

one hour only, about one half of the precipitate was digested two hours after incubation, and after forty-eight hours all, or nearly all, was digested. This point was studied directly by several series of experiments, of which the following is an illustration.

*Experiment 3.* — Twelve bottles, each containing 10 c.c. of pepsin solution No. 20 (1 per cent pepsin, 0.1 per cent HCl) with air in the space above, were shaken variable periods in thermostat at 33° C. at the rate of about 150 per minute. The pepsin was tested by the edestin method (Fuld). Table III. gives the percentages of destruction to the duration of shaking.

This and other similar series of experiments prove to a certainty that the duration of the shaking has a manifest influence upon the degree of destruction of the pepsin; the longer the shaking lasts, the more of the pepsin becomes destroyed. The destruction is, however, not directly proportional to the time of shaking. The

main destruction takes place within the first eighty minutes of shaking. What is left of the activity of the pepsin proves quite resistant and gives way very slowly to the destructive influence of the continued shaking.

**Influence of temperature.** — Of great influence upon the destructive effect of shaking is the temperature at which the shaking is

TABLE III

No. of bottle.	Duration of shaking in minutes.	Percentage of destruction.	No. of bottle.	Duration of shaking in minutes.	Percentage of destruction.
293	5	15+	300	60	80 ±
294	10	35+	301	82	90 ±
295	15	43	302	102	95 ±
296	20	45 ±	303	131	97 ±
297	30	50-60 ±	304	186	98 ±
298	40	55-56 ±	305	264	98.5 ±
299	50	74 ±	....	....	....

being carried on. As stated previously, shaking was carried on by us also in a machine which is located in the basement of the building, where the room temperature is generally lower than in the upper parts and is subject to the influence of the fluctuating external temperatures. The temperature surrounding this machine was sometimes as low as 13° C. and was rarely, if ever, higher than 23° C. The following table illustrates the influence of shaking at a temperature of 21° C.

TABLE IV.

DESTRUCTION OF PEPSIN BY SHAKING AT 21° C., TESTED BY THE EDESTIN METHOD.

Duration of shaking.	Percentage of destruction.
30 minutes . . . . .	22 per cent
90 minutes . . . . .	56 per cent
180 minutes . . . . .	62 per cent
372 minutes . . . . .	94 per cent
726 minutes . . . . .	99 per cent

Each of these figures was derived from several experiments, the results of which, however, varied but little in each case. For instance, the figure for the percentage of destruction by shaking one hundred and eighty minutes was derived from different analyses which gave the figures: 70, 65, 64, 60, 60, 60, 60, 60. A comparison with Table III will show the striking difference in the effect of shaking at a temperature lower by 12°. Shaking at 33° C. for thirty minutes destroyed at least 50 per cent, while the same duration of shaking at 21° C. destroyed only 22 per cent of the pepsin. The same difference holds good for longer periods of shaking. The importance of the duration of shaking is, at the lower temperature, even more manifest than at 33° C., and striking is here also the resistance of the undestroyed residuum of pepsin: after six hours' shaking the destruction was 94 per cent, and after twelve hours there was still at least 1 per cent pepsin left undestroyed.

**No reactivation.** — In a number of experiments after shaking for periods which usually produce more or less complete destruction, some of the bottles containing this shaken pepsin were kept in the refrigerator (5° C.) and some in the thermostat (38° C.) for various periods. It was found on testing even after six days that there was no sign of a recovery of the ferment activity.

**Presence of beads indifferent.** — In some experiments the bottles subjected to shaking contained a fair number of solid large beads. We could not find that the presence of the beads favored in a notable degree the destruction of the pepsin.

**No destruction in full bottles.** — In some other experiments all air was excluded, the shaken bottle being filled to the stopper with the pepsin solution. In these bottles there was hardly any destruction of the pepsin. Even after shaking continually seven days, the destruction was not more than 4 per cent, if so great, compared with that of the control. All of these bottles contained beads. There is very little shock communicated to the fluid when it cannot move within the bottle.

**Shaking in paraffined tubes.** — In one or two experiments the bottles to be shaken were paraffined inside before they received the pepsin solution. The destruction was practically the same as in non-paraffined bottles.

**Shaking in sealed tubes.** — In order to exclude the possible chemical effect of the rubber in a number of experiments the shaking was carried out in test tubes, the mouths of which were sealed on the

gas flame. An exact comparison of the results could not be made on account of the difference in the diameter and the volume of the bottles. However, the destruction of the pepsin in the sealed tubes was as prompt as in the bottles with the rubber stoppers.

**HCl a favorable factor.** — In the majority of the experiments, as stated above, hydrochloric acid was added to the pepsin, which acted at the same time as an antiseptic. In many experiments, however, toluol was added to the pepsin solution instead of HCl. (In control experiments it was first established that toluol alone hardly interferes with the action of pepsin.) The destructive effect of the shaking was manifest also in these experiments. It appeared, however, that the destruction was not as marked in these solutions as in those which contained HCl. In a few instances the pepsin solution contained only water. In these cases also the destruction was not as good as when the solution of pepsin contained HCl. From these facts it appears that the presence of HCl favors the destructive action of shaking.

**Influence of rate.** — We have not made systematic observations upon the influence of the rate of shaking upon the destruction. But an analysis of the data shows that the destruction was manifestly more rapid when the number of movements of the bottles per minute was greater.

**Addition of peptone.** — Only four experiments were made with the addition of 1 per cent peptone to the pepsin solution (with HCl). The destructive effect of shaking was strikingly reduced — destruction amounting to only 25 per cent or less in shaking for twenty hours at 33° C. Glycerine also appears to retard greatly the destructive effect of shaking. However, the number of these experiments is too small to permit at present a definite conclusion in this regard.

**Shaking gastric juice.** — In addition to shaking pure solutions of (commercial) pepsin in a number of experiments the gastric contents of a dog were shaken from two to twenty-four hours. The general result is that the pepsin in these contents becomes also destroyed by shaking. However, there are apparently a number of qualifying factors connected with the pepsin of the gastric juice of the dog's stomach which have not yet been studied. We shall therefore not enter into the particulars of these experiments.

**Shaking by respiratory movements.** — On the supposition made by Meltzer in the paper on the "Importance of vibration," that the

rhythmical shocks within the animal body, like those made by the cardiac and the respiratory movements, are capable of producing vibratory effects, the attempt was made to expose pepsin solutions to the effects of such movements. Two series of experiments were instituted to establish this purpose. In one series suitable bottles containing solutions of pepsin were introduced into the stomach of a dog through an œsophagus fistula. In another series such bottles were placed in the peritoneal cavity of rabbits. For the stomach experiments either small vials were used, closed by rubber stoppers and tightly secured by rubber dam against the entrance of gastric juice, or small glass tubes sealed on the gas flame; or the pepsin solution was placed in tightly closed rubber finger cots. In all cases the containers were kept within the stomach, secured by a cord attached to them by one end, while the other protruding end was tied around the neck of the animal. The bottles within the stomach did not inconvenience the animal, which partook of food in the usual manner. For the peritoneal cavity small bottles with stoppers or sealed glass tubes were used. They were introduced through a small opening which was immediately sutured. In either case the bottles remained in their respective places for various periods, in the case of the peritoneal cavity as long as seven days.

There was a definite destruction of the pepsin in practically all experiments. In the stomach the greatest reduction took place in the rubber finger cots. (They were used on the supposition that in these soft containers the pepsin solution might be subjected to the "massaging" effect of the movements of the diaphragm.) However, even here the reduction was not higher than 40 per cent compared with the activity of the pepsin in the control kept for similar periods in the thermostat at about  $38^{\circ}$  C.

In the bottles which were kept in the rabbit's abdomen the destruction of the pepsin was definitely more pronounced than in those kept in the dog's stomach. However, maximum thermometers, which were simultaneously kept within the abdomen, indicated that the temperature there, at least at times, must have been higher by a degree or two than the temperature in the rectum of the animal or in the thermostat in which the control was kept. Since it was found (Shaklee) that difference in temperature even only of a few degrees when lasting for days is capable of producing a palpable difference in destruction, it was difficult to ascertain how much of the observed destruction might have been due to the

action of the temperature. While we are thus not entitled on the basis of our present experiments to give definite data, we may be nevertheless justified in stating that in these experiments there was a degree of destruction above that which could be accounted for by the effects of the elevated temperature. Our provisional theory is that this part of the destruction is due to the shaking caused essentially by the respiratory movements.

#### THE INFLUENCE OF SHAKING UPON TRYPSIN.

**Quantitative method.** — For the quantitative determination of trypsin the method of Gross<sup>17</sup> was used which is based upon the fact that acetic acid causes a turbidity in an alkaline casein solution, but not in the solution of the caseoses. In the method recommended by Gross the procedure is as follows: Into each of a series of test tubes, 10 c.c. of an alkaline casein solution is run (casein solution — 1 gm. of casein and one of  $\text{Na}_2\text{CO}_3$  to 1000 distilled water). To each of these tubes increasing quantities of the solution containing trypsin is added and the tubes incubated in a thermostat at 40° C. After fifteen minutes a few drops of acetic acid is added to each tube, which produces a turbidity in the tubes in which digestion is incomplete. The strength is calculated from the smallest quantity of the trypsin solution which prevented the appearance of turbidity.

A modification of this method was used in this research similar to that which was used in the determination of pepsin. To two of a series of test tubes, equal (standard) quantities of a standard solution of trypsin were added, and into the other tubes increasing quantities of a chosen dilution of the solution to be tested were run. The volumes were made equal, and then 2 c.c. of a neutral casein<sup>18</sup> solution were run into each. The tubes were incubated for an hour or two in the thermostat at 40° C. Then a saturated solution of NaCl in a 5 per cent aqueous solution of acetic acid was run down the side of each tube and allowed to stand fifteen to twenty minutes. The rings which were formed in the test tubes containing the solution to be tested were compared with the rings of the standard tubes. The tube containing a ring similar to that of the standard tube was selected, and from the quantity of shaken trypsin of that tube compared with the quantity of unshaken in the standard tube, the strength of trypsin was calculated and expressed in per cent of the original strength.

<sup>17</sup> GROSS: *Archiv für experimentelle Pathologie und Pharmakologie*, 1907, lviii, p. 157.

<sup>18</sup> KUDO: *Biochemische Zeitschrift*, 1908, xv, p. 473.

Grübler's trypsin was used in 0.1 per cent solutions. The shaken solutions were usually alkaline, some containing toluol. In a few instances aqueous solutions were shaken.

**Results.** — The main result is here again that shaking exercises a destructive effect upon trypsin. We shall not enter here into many details. The following short table will illustrate the main points.

TABLE V.

SHOWING THE EFFECT OF VARIOUS DURATIONS OF SHAKING TRYPSIN (0.1 per cent)  
AT 21° C.

Duration of shaking.	Percentage of destruction.
30 minutes . . . . .	68 per cent
90 minutes . . . . .	83 per cent
186 minutes . . . . .	90 per cent

The figures given here are averages from several experiments in which each individual figure was lower or higher than the average by only 1 or 2 per cent.

We learn from this table that trypsin is readily destructible by shaking, that the destruction takes place in a very marked degree, even at such a low temperature as 21° C.; that the main destruction takes place within the first half-hour, and that the smaller the residuum of the trypsin is, the greater is its resistance to the destructive effect of shaking.

**Different trypsins.** — With reference to the last-mentioned point we wish to say that according to Vernon<sup>19</sup> trypsin consists of several trypsins which differ in their resistance to the destructive action of Na<sub>2</sub>CO<sub>3</sub>. We may therefore assume these various trypsins differ perhaps also in their resistance to the destructive influence of shaking.

**Trypsin less resistant than pepsin.** — The table indicates also the interesting fact that trypsin is more readily destroyed by shaking than pepsin: more was destroyed of trypsin (0.1 per cent) in thirty minutes at 21° C. than of pepsin (1.0 per cent) by shaking forty minutes at 33° C. The difference between the resistance of the two proteolytic ferments was found to exist also when both were shaken in distilled water and in the same concentration.

<sup>19</sup> VERNON: *Journal of physiology*, 1900-1901, xxvi, p. 405.

## THE INFLUENCE OF SHAKING UPON RENIN.

**Method of testing renin.** — Pepsin solutions, neutralized to litmus, were used for the study of renin. To two of a series of tubes standard volumes of a standard solution of the ferment were added, and into the remaining tubes increasing quantities of a chosen dilution to be tested were run in. The volumes were made equal, and finally 5 c.c. of skimmed fresh milk (+ 0.4 per cent CaCl) was quickly run into each tube. The tubes were kept at room temperature for about fifty minutes. The action of the ferment was indicated by the appearance of an incipient coagulum on the side of the tube after tipping it. The measure of ferment strength was obtained by determining how much of the solution to be tested was necessary to produce the same coagulation effect as a given quantity of the standard solutions.

**Result.** — It may be briefly stated that renin was destroyed by shaking practically in the same degree as pepsin. Shaken solutions of pepsin have shown nearly the same destruction of their renin contents, when tested in neutral solution, as was found for the pepsin content, when tested in acid solution. All the various conditions which influenced the resistance of pepsin to the action of shaking acted in the same manner also on renin. For reasons which will be manifest later we should mention especially that the presence of HCl in the pepsin solution favored the destruction of renin.

**The rise of temperature by shaking.** — It has been urged by some writers that the effect of shaking might be due to a rise of temperature produced by the shaking. Although it is fairly obvious that the degree of destruction which we have observed in this research could not have been caused simply by the rise of temperature, we tried to establish by direct observation the rise of temperature which is produced by such shaking as we employed. Through a hole in the side of a bottle which contained pepsin solution and beads a maximum thermometer was tightly inserted so that the part containing mercury was bathed in the solution. The thermometer was thus placed at a right angle to the axis of the bottle so that the movements of the bottle could not affect the column of mercury. The bottle was wrapped in heavy paper. The result is a surprise: in five experiments the highest rise was less than 0.3 C.



Summing up our experimental results, we have to say that without laying too much weight upon the details which were ascertained or upon the exactness of the figures which were obtained in these researches, the gross results were of such a kind as to leave no doubt regarding the truth of the following facts: all three proteolytic ferments can become completely destroyed by shaking, at least by such shaking as was in use in this research. The destruction or inactivation was not reversed within six days, during which period some of the shaken ferment solutions were kept in the refrigerator and some in the thermostat. Higher temperatures ( $33^{\circ}$  C.) favor destruction by shaking. The duration of shaking is also an important factor in the action of shaking; the longer the ferment solution is shaken, the more of it becomes destroyed. On the other hand, the smaller the undestroyed residuum of the ferment becomes, the longer it takes to destroy it. There is a great deal of difference in the resistance to the destructive effect of shaking between pepsin and trypsin. The bulk of the latter is more readily destroyed and at lower temperatures than pepsin. However, an undestroyed small residuum of trypsin retains a remarkable resistance which is, perhaps, even greater than that of the residuum of pepsin. There is practically no difference in the effects of shaking between pepsin and renin. It is probable that the respiratory movements are capable of producing some degree of destruction upon the proteolytic ferments exposed to their action.

#### RESULTS OF OTHER INVESTIGATORS.

When we started this research, we were not aware of any investigation or statement bearing upon the possibility of a destructive effect of shaking upon the activity of ferments. However, soon after the appearance of our preliminary communication in the "Zentralblatt für Physiologie" Professor Abderhalden was kind enough to send us an article by himself and Guggenheim,<sup>20</sup> calling our attention to a passage in it which deals with the destructive influence of shaking upon solutions of tyrosinase. After shaking it for twenty-four hours at  $37^{\circ}$  C. it lost its activity greatly. It was strikingly inhibited also when shaken at room temperature.

<sup>20</sup> ABDERHALDEN and GUGGENHEIM: *Zeitschrift für physiologische Chemie*, 1908, liv, p. 352.

Similar experience they had with zymase: shaking forty-eight hours at room temperature retarded its fermentative activity considerably; when shaken for twenty-four hours in the incubation chamber, it became completely inactive. Experiences of that kind they had also with pancreatic juice, but they give no particulars.

In the course of this summer two more articles appeared which deal with the influence of shaking upon ferments. One concerns us directly, as it deals with the influence of shaking upon renin; it is by Signe and Sigval Schmidt-Nielsen.<sup>21</sup> They prepared the renin from the mucosa of the calf's stomach. Their shaking was done by an apparatus in which the bottle was fixed, but the solution within it was agitated by means of a perforated plate moving to and fro in the direction of the long axis of the bottle two hundred and fifty times per minute. The destructive effect upon the renin was judged by the time it required to cause coagulation in milk. Their report contains no statement showing a complete destruction of the renin by shaking. The longest duration of the shaking which is mentioned in their communication is only one hour. They obtained, however, already a considerable degree of "inactivation" of renin by shaking it only a few minutes, and this at a temperature of only 16° C. The inactivation was the more complete, the greater the rate of shaking, the longer it lasted and the higher the temperature was at which it was shaken. So far the statements of the Schmidt-Nielsens are essentially in agreement with ours. They state, however, that they could not obtain any results with commercial preparations of renin on account of the presence of HCl in these preparations, which in their experience prevents the "shaking-inactivation," as they term that phenomenon. In our experience rather the reverse was the case, the presence of HCl favored the destruction of renin as well as that of pepsin. However, we should not enter into a discussion of some minor discrepancies between the two investigations. The entire subject is new, and we welcome any statement which is in agreement with the fundamental facts in this research.

The second paper is by Harlow and Stiles,<sup>22</sup> on the effect of shaking upon the activity of ptyalin, and was induced by our preliminary communication. Shaking dilute saliva (1:10) in plain

<sup>21</sup> SIGNE and SIGVAL SCHMIDT-NIELSEN: *Zeitschrift für physiologische Chemie*, 1909, ix, p. 426.

<sup>22</sup> HARLOW and STILES: *Journal of biological chemistry*, 1909, vi, p. 359.

bottles reduced the digestive effect upon starch only moderately; the reduction was improved by the addition of glass beads. The greatest part of the reduction occurred during the first half hour, afterwards it proceeded in a diminished rate. By this method the ptyalin ferment was never reduced to more than half of its activity. The activity was further reduced by the introduction of new beads; but the authors never succeeded in rendering the ferment completely inactive.

Wisps of glass wool were more effective than glass beads. Unclean glass beads or glass beads heated to redness had no effect.

If we understand the description of the arrangement for shaking in the experiments of Harlow and Stiles, the bottles must have remained at all times in a vertical position and the liquid within the bottles could have received only moderate shocks. The effect of shaking by such a method is therefore not comparable with the action of such effective methods as were employed by us and the Schmidt-Nielsens, and probably also by Aberhalden and Guggenheim. The fact, however, that even by their moderate mode of shaking (and apparently at room temperature) Harlow and Stiles have evidently observed a definite reduction of the digestive power of the ptyalin ferment confirms the chief point of the contention that shaking is capable of reducing the activity of a ferment.

We have thus now definite data for the action of shaking upon several ferments. Aberhalden and Guggenheim established that shaking for twenty-four hours at the incubation temperature or twice as long at room temperature inhibits completely the fermentative effect of an oxydase and of zymase. We have shown that by our method of shaking the activity of all three proteolytic ferments can be completely abolished within a much shorter time. The Schmidt-Nielsens have found that by their method of shaking more than one half of the activity of renin can be destroyed in a few minutes. Harlow and Stiles observed a reduction of the activity of ptyalin by shaking. Furthermore, we have to mention that Aberhalden and Guggenheim state that they obtained similar results from shaking pancreatic juice. Probably the activity of all three ferments of that juice were inhibited by shaking. With regard to the action of shaking upon lipase, we have yet to mention that an abstract of a paper on "Human pancreatic juice" by Harold C. Bradley,<sup>23</sup> presented at the last meeting of the

<sup>23</sup> BRADLEY: *Journal of biological chemistry*, 1909, v, p. 191.

American Society of Biological Chemists, contains the brief statement that "continuous shaking in a machine was found to inhibit the digestion (of fat) markedly."

Summing up, we may therefore state that as far as the digestive ferments are concerned, we have for each of the ferments evidences from two sources that shaking is capable of exerting a destructive influence upon their digestive activity. Taking further into consideration the observation of Abderhalden and Guggenheim that shaking can completely inhibit also a vegetable oxydase (tyrosinase) and of zymase (or only the proteolytic activity of the latter?), we are justified in making the general statement that a certain degree of shaking is capable of reducing or completely inhibiting the fermentative action of enzymes. Furthermore, since in our experiments pepsin and trypsin were subjected to exactly the same method of shaking, and in some experiments even all other conditions being exactly the same and nevertheless trypsin was distinctly more readily destroyed than pepsin, we may draw the further general conclusion that ferments differ in their resistance to the same degree of shaking.

As to the nature of the effect the Schmidt-Nielsens speak intentionally of "inactivation," meaning hereby that the effect is only a temporary one and is reversible. Abderhalden and Guggenheim avoid the term injury and prefer to say that the ferment becomes inactive or that the activity becomes inhibited. We are speaking in this paper of the destruction of the ferments. The existence of the ferments is known only by their activity. In our experiments we have seen the complete disappearance of these activities and have not seen any sign of a return of these activities, even after keeping the shaken solutions of these enzymes in the incubator for a good many days. As to the statement of the Schmidt-Nielsens that in their experiments "die Schüttel-Inaktivierung unter gewissen Umständen einen gewissen reversiblen Prozess darzustellen scheint," we cannot discuss it properly until they have stated under which conditions the process "seems" to be reversible. But we wish to say this: even if we assume that by a certain degree of shaking the ferments are irrevocably destroyed, we may well admit that preceding this final state all or some of the "molecules" of the ferments become "shocked," paralyzed, inactivated, and that if in that stage the shaking is not continued, these shocked molecules may recover and become active again. We

can say that in our experiments not a single fact was observed which could have been interpreted in that way; but we are willing to admit the possibility of such an occurrence. But a few occurrences like that would not yet signify that the entire effect of shaking is mere inactivation. We may mention here that in the experiments by Meltzer with one of the water bacteria of which usually a complete destruction by shaking was obtained, it occurred sometimes that after keeping the cultures (unopened) for some time, some colonies would appear which at first would have a growth different from that peculiar to that organism, but gradually it would assume the character of the colonies of the original micrococcus. Such colonies were always only few in number. The interpretation of this phenomenon was that sometimes a few of the organisms survived the fatal effect of shaking, but even these survivors received a shock, from which they recovered only slowly.

We have to call attention to another point. While shaking causes an effect which is specifically due to that factor, by the methods of shaking as they are employed at present in the still primitive stage of development of our subject, some of the injurious effects met with in some of the shaking experiments might be due to some other injurious factors which it is difficult to separate from the shaking effects. The Schmidt-Nielsens indicate such possibilities. It is possible, for instance, that the results of Harlow and Stiles may be due to two causes: to shaking and to adsorption.

#### DISCUSSION.

We are now coming to a discussion of the nature of the process which causes the destruction or inactivation of the ferment by shaking. We have stated in a previous section the hypothesis which led us up to this investigation. The results as far as they went are in agreement with the anticipation raised by that hypothesis. This, however, does not yet prove that our hypothesis is indeed the only explanation of this process. There are other possible interpretations of the phenomenon, and we shall now try to see the merits of them. We shall discuss first such interpretations as would explain the results of shaking by other than mechanical effects. That it is not due to an alkalinity produced by a solution of the glass was shown in our experiments by the fact

that the shaken solutions were still acid; that the effect was the same when the bottle was paraffined; and in the Schmidt-Nielsens experiments it was shown by the fact that the results were the same, even when the shaking was carried out in stone bottles. That it is not due to a rise of temperature caused by the shaking, as some are inclined to suppose, is proven by the fact that the direct test demonstrated that the rise did not reach even  $1^{\circ}$  C., and furthermore a rise of even  $10^{\circ}$  C. would never produce such a destruction in such a short time. That the destruction was not due to an oxidation by the oxygen of the air within the bottle was proven by the fact that the destructive effect remained the same when the space above the liquid within the bottle was filled with hydrogen or carbon dioxide.

Turning now to the physical explanations of the phenomenon, we have to mention that, according to the opinion of Abderhalden and Guggenheim, it is very probable that the precipitations which form by shaking pull down the ferments. But then they add that "since the loss of ferment activity occurs also in clear solutions, it is evident that a direct precipitation is not necessary for the inhibition of the ferment activity." Which, then, in their opinion, is, under these last-mentioned circumstances, the real cause of the inhibition of the ferment activity, the authors do not make clear. Harlow and Stiles say that "while we are convinced that the removal of the enzyme by contact with surfaces has been the chief factor in our experiments, we have seen some reason to believe in a secondary influence of the shaking, either an agglomeration or a disintegration of molecules it may be." The authors say that the effect of contact with surfaces "is analogous to the removal of enzymes from solutions by precipitates and filtration." The authors have probably in mind the phenomenon of adsorption of ferments. The Schmidt-Nielsens consider the inactivation by shaking as a new phenomenon and do not discuss the probable nature of it.

As far as we can see two explanations are open to those who are disinclined to assume that we deal here with a new phenomenon. One is that the ferments are carried down by a precipitate, and the second is that the ferments are removed from the solution by the adsorption to the wall of the bottle in which it is shaken. As to the first explanation, it cannot mean that it is carried down by visible precipitations, since the activity of the ferment is in-

hibited by shaking even when, as Abderhalden and Guggenheim state, the fluid remains perfectly clear. However, this view might find a support in Ramsden's observations<sup>24</sup> that shaking of a solution of albumen produces a coagulation, or, as Mann<sup>25</sup> says, a conglutination. It might then be assumed that the proteids closely connected with the ferments themselves coagulate and thus imprison the ferment; these fine particles, however, are perhaps too small to cause perceptible turbidity. But is it probable that these particles will be capable of holding the ferments imprisoned forever? Moreover, why should this infinitesimal amount of coagulated proteid not become rapidly digested by the pepsin and the HCl which are present in abundance in these solutions? Furthermore, according to Ramsden, the mechanical proteid coagula are dissolved in alkaline solutions becoming alkali-albuminates. How should, then, the trypsin ferment in the alkaline solution be imprisoned in these proteid masses, and why should the latter not be digested? It seems to us that this interpretation is far from being plausible.

The second interpretation would assume that by shaking a solution of ferment in a glass bottle the entire quantity of the ferment would be withdrawn from the solution and become adherent to the wall of the smooth glass bottle, remaining there adherent permanently, and thus destroy the activity of the ferment. The basis for this assumption is, as indicated before, the well-known phenomenon, discovered by Von Wittich, of the adsorption of ferment to fibrin and to some other substances. We need not enter into a discussion of the probability of such an assumption. It suffices to call attention to the fact that among the experiments on adsorption of pepsin we find such ones in which after shaking pepsin solutions for an hour in a glass bottle, even with an admixture of a quantity of powdered glass, no adsorption took place, either to the wall of the bottle or to the powdered glass; the entire quantity of pepsin was recovered from the filtrate.<sup>26</sup> It seems to us that, on the contrary, some phenomena which were considered as being due to adsorption might have to be studied over again, since in many of the cases the phenomena were obtained after

<sup>24</sup> RAMSDEN: *Archiv für Physiologie*, 1894, p. 517.

<sup>25</sup> MANN: *Chemistry of proteids*, 1906, p. 273.

<sup>26</sup> DAUWE: *HOFMEISTER'S Beiträge zur chemischen Physiologie*, 1905, vi, p. 426.

shaking the solutions for an hour or longer and the question could be raised how much of the phenomenon was due to shaking.

At all events, it seems to us that the various attempts to explain the destructive effect of shaking upon ferments by *known* chemical or physical processes are far from plausible and have, so it seems to us, a less satisfactory basis than the hypothesis upon which, at least in our experiments, the facts of the destruction of the proteolytic ferments by shaking were discovered. We now turn to a discussion of this hypothesis.

**Our theory.** — In the first place, it seems to us that the destruction of the ferments by shaking is analogous to the destruction by shaking of organized, living bodies of microscopical dimensions. For bacteria, yeasts, red blood corpuscles, and echinoderm eggs the profound influence of shaking is now, as it was shown above, a well-established phenomenon. From this point of view the fact of the destruction of ferments by shaking is therefore an entirely new phenomenon no longer. We go further and assume that the nature of the process of destruction by shaking is in both instances the same. Ferments, of course, differ greatly from living organisms. But even red blood corpuscles differ considerably from living organisms, — they are incapable of reproduction and probably also of growth. Nevertheless we do not hesitate to designate them as cells, and certainly as living cells. Our assumption is that ferments have a certain structure, an organization; that this organization they have in common with living organisms and red blood cells, and that shaking affects all three categories of beings by attacking this structure. Life is something in addition; but that structure is indispensable to life. On the other hand, it is this structure which distinguishes organized bodies from simple aggregates of colloid organic matter. These two kinds of bodies react in a fundamentally different way to heat, light, or shaking. We shall discuss here only the difference in the reaction to shaking. Shaking breaks down organized bodies by molecular disintegration, by converting them to dust; shaking affects colloid organic tiny clumps by uniting, coalescing them to masses somewhat larger in size than before, just as was observed by Ramsden that shaking of solutions of proteid brought about threadlike formations. This contrast in the effect of shaking was observed by Meltzer in continuous shaking of red blood corpuscles. The first effect of the shaking was the gradual conversion of the corpuscles into dust;



the continuous shaking of this dust, however, converted it into threadlike ragged masses.

We distinguish, then, between living bodies, organized bodies, and unorganized colloid, organic masses. *Living bodies are organized bodies plus life*, and shaking attacks the organization in both kinds of organized bodies in the same manner. Ferments are organized bodies (not to confound with the older expression of organized ferments), and shaking attacks their structure in the same manner as it attacks living cells. In both cases the destruction is in the nature of a molecular disintegration.

This is one part of our theory or rather one of the hypotheses. There is another part to our theory, another hypothesis which is however not indispensable to the support of the first one. It refers to the nature of the organization of the structure of these bodies. It assumes that in organized bodies the physical molecules are united into groups, physiological units, which are disconnected among themselves and are surrounded by layers of fluid which are connected throughout the entire organized body. This organization permits the vibration of the physiological units, which is transmitted to them from outside (from the continuous vibrations going on in the inorganic world or from the shocks within the living complex organism), and which is essential for carrying on metabolic processes throughout all or many of the organized bodies.<sup>27</sup> Violent shaking causes a sudden disintegration of this organization, a *disbanding of the physiological units*. (Temperature affects the very same structure, hence the greater effect of shaking under higher temperatures.) It is self-evident that this organization will vary greatly in its details in the different species as well as among the individuals of the same species of organized bodies. Shaking, therefore, will affect differently different species, and also differently some individuals of the same species. Hence the rapid inactivation of the greatest part and the resistance of the remaining part of shaken ferments, and hence the difference in the resistance to shaking between different ferments or between different living cells.

In unorganized colloid organic matter the relations are perhaps just the reverse: a continuous connection between irregular groups

<sup>27</sup> We do not wish to express here an opinion with regard to the occurrence of metabolic processes of some kind in ferments; our theory does not require such an assumption.

of the fine solid particles by means of threads, fibres, pellicles, and a disconnection between the enclosed liquids. Shaking, therefore, in a general and violent way causes a coalescence of the solids and not a disintegration.

The details of the organization and the character of the vibrations of the physiological units in ferments probably differ greatly from that in other organized bodies and differ specifically in each enzyme.

#### NON-SPECIFIC AND SPECIFIC VIBRATION.

In the foregoing we stated that the vibrations of the physiological units, within the living cells as well as within ferments, have their origin in external causes, in external shocks, shakings, and vibrations of all sorts. These external non-differentiated shocks communicated simultaneously to several organized bodies may produce in each body vibrations peculiar to that body on account of the specificity of the organization. There may be, however, such external shakings which are better adapted to the vibrations of one body than to those of another; they are in this case adequate or specific shakings. We may then go a step further and say that the vibrations of these organized bodies may again in their turn affect other bodies in a general as well as in a specific way. In mixtures of bacteria the lively moving organisms may affect their neighbors by favoring the metabolism, accelerating the process of division and hastening the breaking down of the decrepit individuals (Meltzer<sup>28</sup>). This is an instance of a general effect. As a specific effect we may perhaps cite the action of the motile spermatozoön. It is possible that *the shock which the ovum receives from the impact of the speeding spermatozoön is an accelerating mechanical factor in the cleavage processes which follow within the ovum.* These shocks are perhaps indeed specific ones: the specific movements of the starfish sperm are adequate for the starfish egg, and the specific motility of the arbacia sperm is adequate for an arbacia egg (Meltzer<sup>29</sup>). Whereas artificial shakings are effective for both eggs only when violent and when causing destruction: mild non-specific shaking starts cleavage only in starfish and amphitrite eggs, it does not affect arbacia eggs.

<sup>28</sup> MELTZER: Zeitschrift für Biologie, 1894, xxx, p. 464.

<sup>29</sup> MELTZER: This journal, 1903, ix, p. 245.

Extending this very assumption to the ferments, we may perhaps state that the vibrations of ferments exert in some instances a non-specific effect, causing a variety of cleavages in various substances, and in other substances the action is definitely specific — like a key to a lock. This leads up to the revival of Naegeli's theory that ferment action is due to a specific molecular vibration, — into a discussion of which, however, we shall not enter, as it is outside of the scope of the present paper.

We may, however, point out very briefly that the so-called inorganic ferments have a structure similar to the one we assumed to be possessed by the enzymes, *i. e.* extremely fine, discrete, solid particles surrounded by very fine connected films of fluid.

We have assumed that living cells and enzymes are built up of physiological units. We wish to say that these units have nothing to do with Verworn's Biogenes, Adami's Biophores, or Rubner's Bionts. Or, more correctly, we wish to express no opinion as to the relations in which our physiological units may stand to the units of life. We do not discuss the nature of life in this paper. We only assume that bodies which are affected by physical factors like vibration, heat, and light, in a similar manner have a similar organization upon which the physical factors exert their influence. Life is something in addition to this organization. What life is, what its units may be, are questions with which we do not deal in this paper.

#### SUMMARY.

The more essential results of our experiments are the facts that shaking may completely destroy the three ferments, — pepsin, renin, and trypsin; that they are destroyed more rapidly at higher than at lower temperatures; that trypsin is more easily destroyed than pepsin; and that the shaking produced by the respiratory movements is capable of causing some destruction of the ferments.

Recent experiments by other investigators show that also other ferments may be inactivated by shaking.

Numerous older experiments have established that shaking is capable of influencing fundamentally bacteria, yeast, red blood corpuscles, and echinoderm eggs.

The assumption is here made that the nature of the destruction

of ferments is similar to that which takes place in the destruction of living cells, and that shaking affects a certain structure which is common to living cells as well as to red blood corpuscles and to ferments. The further details of this theory cannot be included in the summary.

## THE EFFECT OF SUBMINIMAL STIMULATION OF THE PNEUMOGASTRIC NERVES UPON THE ONSET OF CARDIAC RIGOR.

BY DON R. JOSEPH AND S. J. MELTZER.

[From the Department of Physiology and Pharmacology of the Rockefeller Institute for Medical Research.]

FOR skeletal muscles it is well established that section of the motor nerves retards, and stimulation of the peripheral ends of these nerves hastens, the onset of rigor mortis in the corresponding muscles. On the hypothesis that stimulation of inhibitory nerves may cause a retardation of the onset of rigor, we carried out a series of experiments upon cardiac rigor in which the pneumogastric nerves were stimulated. We published recently a full account of that investigation.<sup>1</sup> The chief result was that the onset of rigor, instead of being retarded as expected, was definitely accelerated. In those experiments the vagi were treated with *effective* stimuli, that is, there were considerable slowing and stoppages of the heart beats. Our interpretation of the result was that the acceleration of the phenomena of rigor was caused by premature cardiac asphyxia, brought on by the great slowing and standstills of the heart. Notwithstanding this result, stimulation of the inhibitory nerve fibres might well have a tendency to retard the onset of rigor, but the retardation in those experiments may have been overcompensated by a hastening due to local asphyxia of the cardiac muscles. This consideration gave rise to the problem which is dealt with in the present paper. — the question whether *ineffective* stimulation of the vagi would bring out the anticipated retardation of the rigor.

The fact that rigor of skeletal muscles appears earlier with nerves intact than with nerves cut was interpreted to mean that subminimal stimuli are continually transmitted from the central nervous system

<sup>1</sup> JOSEPH and MELTZER: Journal of experimental medicine, 1929, xi, pp. 10 and 314.

to the muscles, causing thereby a hastening of the postmortem rigor. In Hermann's laboratories, where the question of the relations of the nervous system to the onset of rigor received manifold attention, Bierfreund<sup>2</sup> approached the subject experimentally and obtained the surprising result that the leg, the cut sciatic of which was stimulated, developed rigor later than the control leg. However, Gotschlich<sup>3</sup> found that subminimal stimulation brought on acidity of the muscle, and B. Danilewsky<sup>4</sup> observed the production of heat in the muscle by subminimal stimulation. These facts caused Meirowsky<sup>5</sup> to take up again (in Hermann's laboratory) the question of the influence of subminimal stimulation upon rigor. The result was this time that treating motor nerves with subminimal stimuli hastens the onset of rigor. Of fourteen experiments twelve were positive, one gave no result, and one had an opposite result, that is, the onset of the rigor was retarded. On the basis of this result we again undertook the study of cardiac rigor under the influence of stimulation of the vagi, using, however, this time *ineffective stimuli*, that is, stimuli which were not capable of influencing the heart beats in a perceptible manner.

**Methods.** — In the previous paper we have shown that in the researches upon cardiac rigor by various investigators, in which the graphic method was employed, a serious error was introduced in the results. The filling up of the ventricular cavity with some fluid for the purpose of connecting it with a manometer caused a tonic contraction of the heart which at some time later went over into rigor without the recognizable occurrence of an intermediate relaxation. Some of the investigators assumed therefore that rigor begins immediately after death. In our observations we left the heart *in situ*, handling it as little as possible. The onset and progress of rigor were judged simply by inspection and palpation, which give reliable results indeed, especially after a little practice. Regarding the particulars of this method we must refer to our previous paper. We wish to mention, however, that in our previous observations we established the fact that three definite periods are to be distinguished in the conditions of the heart between death and maximum rigor. In the first period the ventricles

<sup>2</sup> M. BIERFREUND: *Archiv für die gesammte Physiologie*, 1888, xliii, p. 203.

<sup>3</sup> GOTSCHLICH: *Ibid.*, 1894, lvi, p. 363.

<sup>4</sup> B. DANILEWSKY: *Ibid.*, 1889, vl, p. 353.

MEIROWSKY: *Ibid.*, 1899, lxxviii, p. 64.

show more or less definite although inefficient spontaneous contractions. In the second period the heart is neither beating nor is it in rigor; it is then more relaxed than during a normal diastole. The third period comprises the time which elapses from the beginning of rigor to the attainment of its maximum.

During the second period the ventricles gradually lose their irritability. All periods are much longer in the right than in the left ventricle. The irritability also disappears later in the right than in the left ventricle.

In this series as well as in the former already published the death of the animals was brought about by exsanguination. There was, however, this difference in the method between the two series of investigations: while in the previous experiments the exsanguination was brought on by opening both carotid arteries, it was accomplished in this series, at least in the main experiments, by opening the abdominal aorta. Exsanguination by this method is more complete than by bleeding from the carotid arteries. The respiration usually stopped about five minutes after beginning the bleeding. The thorax was then opened, the heart freely exposed, and the ascending aorta and pulmonary artery opened near their origin. Through these openings the remaining intraventricular blood or clots were gently removed.

For each experiment two animals were used, both as nearly of the same size as possible. Both were etherized and tracheotomized. The etherization was continued in both animals for about one hour. This was done to have both animals under exactly the same conditions, especially since it was found in the last investigations that ether retards the onset of cardiac rigor. In the experiments which gave us our main result, both vagi were exposed and cut in both animals. In one of these animals both vagi were stimulated continually with induction currents for one hour. At the beginning of each experiment the strength of current (the distance of coils) was ascertained, which gave a minimum effect on the heart; then the secondary coil was moved back 100 or 150 mm. With this strength of current, which exerted no perceptible effect, both vagi were stimulated for about one hour, at the end of which both animals were killed in the manner described above.

**Results.** — From ten pairs of dogs — A, control, and B, upon which the experiments were carried out in the manner just described — we obtained the following time averages for the dura-

tion of the various periods or states intervening between death and maximum rigor of the heart. The average time which passed between death and the beginning of rigor (which for our purpose is the most important period) was for the left ventricle in dogs A (controls) seventy-five and in dogs B one hundred and seven minutes; for the right ventricle in dogs A one hundred and nine and in dogs B one hundred and forty-three minutes. In other words, the onset of rigor was retarded in the animals in which the vagi were stimulated — for the left ventricle by thirty-two minutes and for the right ventricle by thirty-four minutes.

The average time which passed between death and stoppage of all spontaneous contractions was for the left ventricle in dogs A twenty-one, and in dogs B forty-seven minutes; for the right ventricle in A twenty-two and in B forty-nine minutes. This means again that in the dogs in which the vagi were stimulated the left ventricle continued beating after death and complete exsanguination twenty-six minutes, and the right ventricle twenty-seven minutes longer than in the control.

The average time which passed from the beginning of rigor until it reached its maximum was for the left ventricle in dogs A eighty-two, and in dogs B eighty-six minutes; for the right ventricle in A seventy-two, and in B seventy minutes. In other words, the average time for the development of rigor in both ventricles from its beginning until it reached the maximum was practically the same for both animals.

The average time which passed between complete stoppage of all contractions and the beginning of rigor — the relaxation period — was, for the left ventricle in dogs A fifty-four, and in dogs B sixty minutes; for the right ventricle in A eighty-eight, and in B eighty-three minutes. In other words, the relaxation time was slightly longer for the left ventricle in the stimulated animal and slightly longer for the right ventricle in the control animal — which means there was but little difference in either direction.

After the ventricles stopped all spontaneous contractions, they were tested either by mechanical stimulation or by electric shocks, as to their irritability. The average time which passed from the stoppage of spontaneous contractions until all irritability ceased, was for the left ventricle in dogs A forty-four, and in B fifty minutes; for the right ventricle in dogs A sixty-eight, and in B eighty-nine minutes. In other words the irritability of the heart,



after stoppage of pulsations in the dogs in which the vagi were stimulated, persisted in the left ventricle longer by six, and in the right ventricle longer by twenty-one minutes than in the hearts of the controls.

Including the irritability of the heart during the period of pulsation, we have the following figures: The average time from death to complete loss of irritability was for the left ventricle in dogs A sixty-five, and in dogs B ninety-seven minutes; for the right ventricle in dogs A ninety-eight, and in dogs B one hundred and thirty-eight minutes. That is—the irritability persisted after death thirty-two minutes longer in the left ventricle and forty minutes longer in the right ventricle of the experimental animals than in the controls.

Maximum rigor is a more definite landmark than its beginning. We shall therefore give here also the average time which passed between death and maximum rigor. For the left ventricle in dogs A it was one hundred and fifty-six, and in dogs B one hundred and ninety-three minutes; for the right ventricle in dogs A one hundred and eighty-two, and in B two hundred and twelve minutes. In other words, the average time for the interval between death and maximum rigor was prolonged in the dogs in which the vagi were stimulated, for the left ventricle thirty-seven, and for the right ventricle thirty minutes.

As to the making up of the averages given in the above data, it must be stated that for the periods which were prolonged in B (stimulated vagi) there was in each case one exception, and in one or two instances two exceptions, that is, cases in which either for the left or for the right ventricle the period for A was prolonged over that for B. However, this prolongation amounted in most cases to a few minutes only, and even this was doubtful in some. On the other hand, in the period of relaxation, as well as that of development of rigor, there were prolongations on one side as many times as on the other.

To recapitulate the results briefly: in nearly all the dogs in which both pneumogastric nerves were stimulated antemortem for one hour in an ineffective manner, that is, with electric stimuli which were incapable of producing a perceptible effect upon the heart beats, there was a definite effect upon the events in the heart after death. These effects were: the onset of rigor was retarded; the completely exsanguinated ventricles beat longer; and their

irritability persisted longer than that of the control animals. The slight shortening of the relaxation period in the stimulated animals might be only a secondary phenomenon and due to the prolongation of the preceding pulsation period. It is a known fact that contractions of a muscle hasten the oncoming of its rigor.

In connection with the foregoing results the following observation is of interest. On three pairs of dogs the following experiments were carried out. In each experiment both dogs were etherized and tracheotomized; then in one dog both vagi were cut, while in the other they were left intact. After a period of seventy-five minutes (or longer) both dogs were killed about the same time by bleeding from the abdominal aorta. The average time of all periods was prolonged in the animals the nerves of which were not cut, with the single exception of the period of pulsation in the right ventricle. Even the average time of the period of development of rigor was retarded in the animals with intact vagi. The cutting of the vagi, then, accelerated the course of the various postmortem phenomena. Since the cardiac vagi of the dog are normally in a state of tonus, we may say that the normal tonus of the vagi retards the onset and development of cardiac rigor. The effect of the tonus, of course, is distinctly only inhibitory in character. These results, therefore, support the assumption that inhibitory impulses retard the onset of rigor. The above three experiments showed further, as mentioned before, that the inhibitory impulses retard also the *development* of the rigor. This was not the case in our stimulation experiments. We must remember, however, that in these experiments we have employed subminimal stimuli, which, with regard to their effect upon the inhibitory nerve fibres, were probably too weak; the artificial inhibitory impulses which they sent to the ventricles were surely weaker than those which are sent normally through the intact vagi, since they produced no such slowing as does the tonus. Had we employed somewhat stronger stimulation, it may have occurred that the development of rigor would also have been retarded. Furthermore, comparing our experiments with those of Meirowsky on motor nerves, we find that the periods of our stimulation were a good deal shorter than the ones employed by this investigator, who stimulated two and one-half, five, and even twenty hours. Here again it is possible that we could have obtained still more striking effects had we extended the period of our stimulation.

SUMMARY.

Antemortem stimulation of the peripheral ends of the pneumogastric nerves with electric currents too weak to produce a perceptible effect upon the heartbeats, prolongs the spontaneous contractions and the irritability of the ventricles after death, and retards the onset of rigor.

It is probable that the relation of inhibitory nerves to cardiac rigor is the reverse of that of motor nerves to the rigor of skeletal muscles.

## NUCLEIN SYNTHESIS IN THE ANIMAL BODY.

By E. V. McCOLLUM.

[From the Department of Agricultural Chemistry, University of Wisconsin.]

MODERN investigations have led physiologists to the belief that in the normal processes of metabolism the protein of the tissues of the animal are the products of a regeneration of these bodies from comparatively simple cleavage products of those proteins taken as food.<sup>1</sup>

Our knowledge of the fate of nucleins in the body and of the origin of the body nucleo-proteins is less clear than of the simple proteins. The nucleo-proteins are complexes, consisting of simple proteins in union with nucleic acid, the latter containing a high content of phosphorus in combination with purine and pyrimidine bases and a carbohydrate group. The earlier investigators established the fact that the proteolytic digestive enzymes, pepsin and trypsin, do not attack nucleic acids in such a manner that purine bases are liberated.<sup>2</sup> More recently Abderhalden and Schittenhelm<sup>3</sup> have studied the behavior of thymus nucleic acid with the pancreatic juice of the dog, and found that this substance is changed in some manner so that the characteristics of nucleic acid are lost, but without the liberation of purine bases. They likewise found that thymus nucleic acid, when digested with extracts of the pancreas and intestinal mucosa of the cow, was speedily liquefied and purine bases set free. This the authors attribute to the presence of intracellular enzymes in such extracts.

The behavior of nucleo-proteins and their cleavage products, the nucleins and purine bases, with individual organs and tissue ex-

<sup>1</sup> See HUGO LÜTHJE: *Ergebnisse der Physiologie*, 1908, vii, p. 795, where a résumé of the researches bearing on this subject is given.

<sup>2</sup> IWANOFF: *Zeitschrift für physiologische Chemie*, 1903, xxxix, p. 31, contains references to the older literature.

<sup>3</sup> ABDERHALDEN and SCHITTENHELM: *Zeitschrift für physiologische Chemie* 1906, xlvii, p. 452.

tracts, has received much attention during the last few years.<sup>4</sup> The existence of four distinct classes of enzymes concerned with the transformations of purines in the body seems to be well established:<sup>5</sup>

1. Nucleases, which liberate purine bases from the nucleic acid molecule.

2. Deamidizing enzymes, which liberate ammonia from adenine and guanine, forming oxypurines, hypoxanthine, and xanthine.

3. Oxidizing enzymes, which oxidize hypoxanthine and xanthine to uric acid.

4. Uricolytic enzymes, which destroy uric acid.

Almost every organ and tissue of the animal body seems to be endowed with the power to bring about one or more changes in the nucleic acids or their products, all of which lead to the final destruction of the component parts of the molecule. These facts lead to the questions: what kind of phosphorus compounds can the animal utilize for the elaboration of the phosphorus containing complexes of its cell nuclei?—and, is an exogenous supply of purine bases essential to nuclein formation?

The work of the investigators cited above all points to a destruction of the nucleic acids taken with the food, rather than a direct transposition of nucleic acid complexes of exogenous origin, and a substitution of these for the portions of the nuclei of the living cells broken down during metabolic activity.

Steinitz<sup>6</sup> attempted to throw light on the question as to whether the formation of nucleoproteins is a chain of syntheses involving inorganic phosphoric acid, by studying the nitrogen and phosphorus retention in a dog fed: (*a*) a phosphorus free protein (myosin) combined with carbohydrate fat and inorganic salts, the phosphorus being supplied in inorganic form, and (*b*) a phosphorized protein (vitellin) combined with the same substances but without the phosphates. He found a better retention of phosphorus, but poorer retention of nitrogen, when vitellin was given and a better retention of nitrogen, but insignificant storage of phosphorus, when myosin supplied the protein of the ration. His experiments were conducted only five to eight days. Leipziger,<sup>7</sup> using the same dog, repeated

<sup>4</sup> BLOCH: *Biochemisches Centralblatt*, 1906, v, pp. 521, 561, 817, 873, gives an extensive résumé of the literature on this subject.

<sup>5</sup> Cf. MENDEL and MITCHELL: *This journal*, 1907, xx, p. 97.

<sup>6</sup> STEINITZ: *Archiv für die gesammte Physiologie*, 1898, lxxii, p. 75.

<sup>7</sup> LEIPZIGER: *Ibid.*, 1899, lxxviii, p. 402.

Steinitz' experiment, using edestin as the phosphorus free protein, and confirmed his observations in a seven-day trial. Zadik<sup>8</sup> and Ehrlich,<sup>9</sup> employing edestin and casein, reached the same conclusion as a result of similar experiments.

The above experiments were all of short duration, and can hardly be looked upon as positive proof of the point in question. It is well known that the elimination of phosphorus is not necessarily constant during a brief period and is influenced by numerous factors, especially by the relative amounts of the alkaline earth and alkali salts in the food.<sup>10</sup>

In an experiment by Hart, McCollum, and Fuller,<sup>11</sup> it has been shown that when pigs were fed on a ration containing a very low phosphorus content, and which proved inadequate for the maintenance of the animals, the addition of phosphorus in the form of calcium phosphate corrected all of the pathological disturbances and led to normal growth and development. Their experiment did not furnish proof of a nuclein or phosphatide synthesis from inorganic phosphates, since their ration still contained small amounts of phosphorus in unknown forms. It was not found possible to secure a basal ration entirely free from phosphorus in sufficient quantity for work with large animals.

It was the purpose of the writer, in undertaking the present series of experiments, to demonstrate whether an animal can rely wholly upon inorganic forms of phosphorus for its supply of this element.

Such a series of experiments involves the maintenance of animals during the growing period upon a ration of artificially prepared foodstuffs, rendered phosphorus free by appropriate methods of purification, inorganic forms of phosphorus being added. This is necessary, since none of our naturally occurring protein-containing foodstuffs are free from organic forms of phosphorus.

Several attempts by other investigators to maintain animals on a ration made up of relative pure proteins, carbohydrates, fats, and inorganic salts have been wholly or partially unsuccessful.

Socin<sup>12</sup> and Hall<sup>13</sup> attempted to maintain mice on a ration con-

<sup>8</sup> ZADIK: *Archiv für die gesammte Physiologie*, 1899, lxxvii, p. 1.

<sup>9</sup> EHRLICH: *Stoffwechselfersuche mit P-haltigen und P-freien Eiweisskörpern*, Inaugural-Dissertation, Breslau, 1900.

<sup>10</sup> EHRSTRÖM: *Skandinavisches Archiv für Physiologie*, 1903, xiv, pp. 82-111.

<sup>11</sup> HART, MCCOLLUM, and FULLER: *This journal*, 1909, xxiii, p. 246.

<sup>12</sup> SOCIN: *Zeitschrift für physiologische Chemie*, 1891, xv, p. 93.

<sup>13</sup> HALL: *Archiv für Physiologie*, 1896, p. 49.

sisting of casein, fat, and sugar or starch and inorganic salts. Socin gave in one experiment also hemoglobin to furnish a supply of organic iron. His mice lived in no case longer than thirty-three days.

Hall added cellulose to his ration to serve as an irritant to the digestive tract and carniferrin to supply organic iron. In no case did he succeed in keeping the animals alive on such a ration more than forty days.

Falta and Nöggerath<sup>14</sup> fed white rats on rations in which the protein was supplied by relatively pure proteins of different sources. Carbohydrates, fats, and inorganic salts were given in addition. With a ration in which the nitrogen was given as serum albumin and casein their animals died after fifty-one to fifty-three days, having lost weight from the beginning of the experiment. When the nitrogen was given as ovalbumin, the rats lived eighty-three to ninety-four days. In a trial in which serum albumin, ovalbumin, and casein were given together in addition to carbohydrates, fats, and inorganic salts, the rats lost weight, as in the preceding experiment, and died in from seventy-one to ninety-four days. The addition of sodium nucleinate, cholesterin, and lecithin gave no better results. The authors believed that the steady decline of their animals was due to either insufficient intake or to lack of utilization of the food consumed rather than an actual insufficiency in the ration.

L. Jacob<sup>15</sup> has contributed some very instructive experiments in this field. Doves were fed a ration consisting of casein, starch, and sugar, fat, and inorganic salts in the form of ash of milk. The ration was calculated to supply protein, carbohydrate, fat, and ash in the same proportions found in the wheat grain. The mixture was pressed into pellets of uniform size. The doves in two experiments were dead or in a dying condition at the end of seventeen days. When meat powder was substituted for casein, the results were the same. On sectioning, the crops were seen to be filled with a compact dough-like mass. Jacob attributed the outcome of the experiment to this difficulty. The birds could not expel the food from the crop, and thereafter vomited everything they attempted to eat. Death was therefore due to inanition.

In one experiment in which cellulose was added better results

<sup>14</sup> FALTA and NÖGGERATH: Beiträge zur chemischen Physiologie und Pathologie, 1905, vii, p. 313.

<sup>15</sup> L. JACOB: Zeitschrift für Biologie, 1906, xlviii, p. 19.

were obtained. Jacob calculated the food value of the pellets fed to the dove, and observed that during the four weeks of the experiment the total intake was equivalent to only seventy per cent of the energy requirement of the bird. The loss in weight was proportional to the energy deficit of the food taken.

The same investigator experimented with rats, feeding a mixture of casein, carbohydrate, and fat, to which inorganic salts were added. The ration was mixed with cellulose. The rats lost weight steadily from the beginning, and died after forty-two, seventy-three, and one hundred and twenty-four days respectively, after the loss of about 40 per cent of their body weight. The difference in the ability of individuals to withstand such a diet is strikingly apparent.

Zadik<sup>16</sup> prepared four different rations as follows:

1. Casein, nutrose, bacon, starch, meat extracts, and meat salts.
2. Nutrose, bacon, starch, and salts.
3. Casein, bacon, starch, and salts.
4. Vitellin, bacon, starch, and salts.

Alternating these rations, he was able to maintain a dog thirty-six days, during which time the animal gained 200 gm. in weight. At this point the dog became ill, and diarrhœa and vomiting necessitated the cessation of the experiment. The dog was unable to eat meat without vomiting. Zadik believed the interruption of the experiment resulted from catarrh of the bladder, brought on by the continued use of a catheter.

G. Marcuse<sup>17</sup> fed a dog casein, rice starch, bacon, and salts during eleven days, and observed a gain of 730 gm. in the animal's weight, and a retention of 11.25 per cent of the nitrogen ingested. The dog likewise retained phosphorus.

Henriques and Hansen<sup>18</sup> fed white rats with a mixture of casein, fat, sugar, cellulose, and salts during thirteen to seventeen days, and observed that they gained in weight and retained nitrogen.

Willcock and Hopkins<sup>19</sup> have reported that a diet containing only zein as a nitrogenous constituent is unable to maintain growth in young mice. The addition of tryptophane, which amino acid is absent from zein, while it does not make it capable of maintain-

<sup>16</sup> ZADIK: *Archiv für die gesammte Physiologie*, 1899, lxxvii, p. 1.

<sup>17</sup> G. MARCUSE: *Ibid.*, 1896, lxiv, p. 223.

<sup>18</sup> HENRIQUES and HANSEN: *Zeitschrift physiologische Chemie*, 1904-1905, xliii, p. 417.

<sup>19</sup> WILLCOCK and HOPKINS: *Journal of physiology*, 1907, xxxv, pp. 88-102.



ing growth, promotes the well-being of the animals and greatly prolongs the survival period.

Another class of experiments should be mentioned in this connection. Abderhalden and Rona<sup>20</sup> were unable to keep a dog in nitrogen equilibrium with a pancreatic digest of casein.

Lesser<sup>21</sup> could not obtain nitrogen equilibrium in a dog fed with a pancreatic digest of fibrin.

Plosz<sup>22</sup> attempted to substitute peptone for protein. He fed a young pup for eighteen days on a mixture of peptone, sugar, and fat, and a salt mixture. The dog gained 501 gm., or 37.5 per cent of its body weight.

In the experiments just described the constituents of the rations used were relatively pure chemical substances except in Zadik's employment of meat extracts and bacon. The former contains unknown nitrogen and phosphorus compounds, and the latter connective tissue and some cellular materials.

We have now to mention several experiments in which a certain amount of naturally occurring mixtures was added to rations composed mainly of simple chemical substances of known composition.

Salkowski<sup>23</sup> fed a ration of eucasein ( $\text{NH}_3$  casein), bacon, rice, and meat extract. A dog ate this for ten days and increased 285 gm. in weight. At the end of the period it refused to take food. In another experiment with the same mixture in different proportions a second dog ate the ration for a period of twenty-four days, gaining 285 gm. in weight. It retained nitrogen and was in a normal condition.

Röhmman<sup>24</sup> fed mice on a mixture of casein, egg albumen, vitellin, nucleoprotein from liver, wheat starch, potato starch, margarine, and ether extract of egg yolk. To these he added sodium and magnesium citrates, calcium lactate, calcium phosphate, dipotassium phosphate, and sodium chloride.

The mice lived ninety-six days on this ration, produced young, and the young continued ninety-four days on the same ration, to

<sup>20</sup> ABDERHALDEN and RONA: *Zeitschrift für physiologische Chemie*, 1905, xlv, p. 198.

<sup>21</sup> LESSER: *Zeitschrift für Biologie*, 1904, xlv, p. 497.

<sup>22</sup> PLOSZ: *Archiv für die gesammte Physiologie*, 1874, ix, p. 323, cited from MALY's *Jahresbericht der Thierchemie*, 1875, iv, p. 21.

<sup>23</sup> SALKOWSKI: *Deutsche medizinische Wochenschrift*, 1806, pp. 225-229.

<sup>24</sup> RÖHMANN: *Klinische therapeutische Wochenschrift*, 1902, xl, p. 1. Cited from MALY's *Jahresbericht*, 1904, xxxiii, p. 823.

which was added about 4 per cent malt. They in turn produced young.

Weiske,<sup>25</sup> studying the effect of a calcium poor ration on the composition of the bones, fed a goat (six to seven years old) on wheat straw which had been thoroughly extracted with hydrochloric acid. To this he added casein, sugar, starch, and sodium chloride.

A second animal received extracted straw, casein, sugar, starch, sodium chloride, and sodium phosphate. A third received the same ration as did the second, except that calcium carbonate was substituted for sodium phosphate.

The second goat would not eat the ration. The third ate the ration readily during forty-two days, when it began to leave some of its feed. There were no signs of illness except that it grew languid toward the end of the experiment.

In another experiment, in which sodium phosphate was used instead of calcium carbonate, the animal showed no signs of illness, but grew feebler day by day and died on the fiftieth day.

In a third series of experiments Weiske and Wildt<sup>26</sup> fed two and one-half months old lambs with the same mixture to which calcium carbonate and sodium phosphate were added. The experiment was continued fifty-five days.

No. 1 decreased in weight from 46 to 32 pounds.

No. 2 decreased in weight from 47 to 34 pounds.

E. Voit calculated, from the data furnished by Weiske and Wildt, that the intake of food by the animals in these experiments was too small for maintenance, and attributed their loss of weight to inanition.

When we consider the causes leading to the unsatisfactory results in the experiments above described, several possibilities are suggested:

1. The animal may have failed because of a lack, wholly or in part, of certain organic complexes in the food given, which the body was not able to supply through its synthetic power from the materials at hand.

2. Certain of the ash constituents essential to the life of the animal can be utilized only when presented in certain organic combinations, whereas in several of the experiments described they were given as

<sup>25</sup> WEISKE: *Zeitschrift für Biologie*, 1872, vii, 1 Abhang. p. 179; 2 Abhang. p. 333.

<sup>26</sup> WEISKE: *Ibid.*, 1873, viii, p. 239; WILDT, *Ibid.*, p. 266.

inorganic salts. Iron and phosphorus might be especially mentioned in this connection.

3. The physical character of the food, especially in respect to lack of bulk and irritating power in the digestive tract.

4. The sameness of the ration.

5. The psychical factor of palatability as influencing the intake and utilization of food.

Concerning the two first-mentioned factors, it would seem that they have been excluded by the experiments described. Falta and Nöggerath met this objection by feeding sodium nucleinate, lecithins, and a variety of proteins with no better results than have been obtained by others with much simpler mixtures in which the iron and phosphorus were given in inorganic forms.

That the physical character of the food might be responsible for the observed inadequacy of the rations in certain cases must be admitted. Lunin,<sup>27</sup> however, found that mice lived indefinitely without any ill effects on evaporated milk alone. Socin<sup>28</sup> fed mice on egg yolk, starch, and cellulose during ninety-nine days, and they remained in excellent condition.

The writer in a preliminary experiment designed to show whether the cellulose was an important factor in Socin's experiment, fed five half-grown mice on boiled egg yolk alone from May 19 to October 7. The five mice together at the beginning weighed 37 gm. At the end of the experiment they weighed 16, 17, 20, 14, and 14 gm. respectively, their collective weight being 81 gm. This ration contained no indigestible matter, but was quite sufficient for normal growth and development of the mice.

In another experiment two young white rats were fed on egg yolk alone. The eggs were hard boiled and the whites completely separated. No. 13 (male) gained weight from 71 gm. at the beginning to 167 gm. at the end of eighteen weeks. No. 14 (female) gained weight from 40 gm. to 160 gm. during the same period. Just before the close of the experiment she gave birth to eight young, which she had made entirely from egg yolk. The ration in addition to being entirely free from indigestible matter contained no carbohydrate. The idea that the sameness of the ration necessarily leads to a failure of the appetite is not compatible with these experiences.

<sup>27</sup> LUNIN: *Zeitschrift für physiologische Chemie*, 1881, v, p. 31.

<sup>28</sup> SOCIN: *Ibid.*, 1891, xv, p. 93.

The work of Pawlow<sup>29</sup> and his students seems to furnish a more satisfactory explanation of the question. The psychic influence of palatability is one of the most important factors in nutrition, either human or animal. Pawlow and his students have shown that the character of the secretions of the digestive glands is profoundly influenced, both in quantity and quality, by the mental sensations accompanying the taking of food. With food possessing little taste, and giving little or no pleasurable sensations on eating, the digestive secretions are scanty and of low digesting power, while the mere enjoyment of eating very palatable foods, even when these never actually enter the stomach, as was the case in his system of "sham feeding," the gastric and pancreatic juices produced by dogs are very abundant and of high digesting power.

Lusk<sup>30</sup> says: "Not only the quantity of the food makes for the well-being, but the quality as well. No amount of actual fuel value could compel the American soldiers of the Spanish War to eat the 'embalmed beef' furnished by the Government. The flavor is to the man what oil is to the battleship. Without flavor in the food the digestive apparatus does not run smoothly."

In the experiments to be described, the hope of success was based mainly on the belief that a ration composed of pure proteins, carbohydrates, fats, and the necessary salts could be made sufficiently palatable to insure a satisfactory intake and utilization of food. The primary object was to limit the phosphorus supply wholly to inorganic forms. All conceivable devices compatible with this end were resorted to in order to change the taste and relieve the monotony of food supplied from day to day.

The first experiment was carried out with two lots of three rats each. Instead of full-grown animals, white rats about half grown or somewhat under half the adult weight were employed, since it was desirable to obtain an increase in body weight. It was believed also that at this actively growing period there is a better ability to utilize food than when growth has ceased.

*Preparation of the food materials.* — The proteins of the food of Lot I consisted of edestin and zein. It was found impossible to prepare any other proteins in the necessary quantity in a phosphorus-free condition. Even with these easily obtainable proteins the necessary degree of purity was attained only with much persistence,

<sup>29</sup> PAWLOW: The work of the digestive glands, 1902.

<sup>30</sup> LUSK: Science of nutrition, 1906, p. 189.

the proteins retaining a trace of phosphorus with surprising tenacity. Zein was purified by pouring its alcoholic solution into water, and repeating this a large number of times. It was then dried, ground as finely as possible and soaked in 0.5 per cent HCl. This treatment was very effectual in removing phosphorus. When the extraction was nearly complete, the protein was dissolved in alcohol, reprecipitated by pouring into water, and the process of drying and extracting with HCl repeated. By presenting new surface for extraction the phosphorus removed by soaking with HCl was greatly increased.

Edestin was repeatedly crystallized by cooling its dilute salt solutions. The content of phosphorus steadily but slowly decreases during this process of purification.

The standard of purity for all foods was the failure of the qualitative test for phosphorus by the Neumann method on 5 gm. of material. Glucose was not at hand in this degree of freedom from phosphorus and was prepared from wheat starch.

Commercial starch contains traces of phosphorus. This can be removed readily by grinding to a fine condition and agitating with a large volume of 0.2 per cent HCl, allowing the starch to settle and decanting the solution.

The cane sugar used was free from phosphorus.

Butter fat obtained by melting butter and filtering the clear fat through paper contains small amounts of phosphorus which can be almost entirely removed by thoroughly agitating the warm fat with slightly acidulated warm water.

The fat used gave only a yellowish tint with ammonium molybdate in nitric acid solution. There was no precipitate from 5 gm. after warming the test solution at 60° for one hour.

In one instance where bacon fat was given to Lot I near the end of the experiment, this contained a small amount of phosphorus in unknown form.

The proteins thus purified still retained an appreciable taste, the edestin much more than the zein, probably due to the great insolubility of the latter in water. As further constituents of the ration, corn starch, wheat starch, butter fat freed from phosphorus as described, cane sugar, milk sugar, pure glucose, cholesterin, and ash of milk were employed. Calcium phosphate and sodium chloride were always added, and at intervals ferric chloride.

At the beginning of the experiment a ration containing 12 per cent of protein, 75 per cent carbohydrate (starch and cane sugar),

5 per cent ash of milk, 5 per cent butter fat, 2 per cent calcium phosphate, and 1 per cent sodium chloride, was made up, mixed with a small amount of finely divided cellulose from filter paper, and enough water added to make a dough. This was dried in an oven at 100° C., cut into pieces and preserved in a Mason jar. The rats ate this with apparent relish for about a week, after which there was evidence of a waning appetite. The sugar content of the food was changed when they again ate more readily. At this time the food was baked thoroughly and a portion fed in this form. At one time slightly caramelized sugar was used to give a new flavor to the food. At another the food was moistened with water distilled from a strong cheese which was finely ground. This water possessed in some degree the cheese flavor and caused the rats to eat with more relish. Good results were frequently obtained by leaving fat out of the food entirely for a few days, changing it as much as possible by the methods mentioned above, then relieving the rats of these flavors by feeding the simple food mixed with fresh butter fat. This invariably induced a good consumption for a day or two. On some days the ration was presented flavored with a trace of banana, celery, cinnamon, lemon, or vanilla flavors obtained from the commercial articles. The rats generally ate the ration on such occasions, but it cannot be determined to what extent the consumption was induced by these substances.

As time went on it was found that when the mixed foods were not eaten readily pure edestin would be consumed with avidity, but only for one feeding. Glucose was frequently given separately, and considerable quantities were eaten. In one instance toward the end of the experiment bacon fat, freshly rendered and filtered through paper, induced a hearty consumption when every other means failed. Cellulose, ground charcoal, and bone ash were given at different times to regulate the condition of the feces. Care was also taken to change the content of the ration in sodium chloride at intervals in order to secure the change in taste which it afforded.

This ration contained no purines. Even during starvation there is a regular elimination of uric acid arising from the breaking down of cell nuclei which necessarily accompanies the functioning of the cells. The rats used in this experiment must therefore have lost nuclear material daily or they synthesized these bodies from the food supplied. Table I shows the records kept during this experiment.

Rat IV was killed on August 11. During seventy-seven days it lost 35 gm. in weight, or 20.59 per cent of its body weight.

Rat V was killed September 7. During one hundred and four days it lost 18 gm. in weight, or 16.66 per cent of its body weight.

Rat VI was killed on August 31. It lost during ninety-seven days 36 gm., or 29.03 per cent of its body weight.

TABLE I.

LOT I. RECEIVED THE INORGANIC PHOSPHORUS RATION AND NO PURINES.

Date.	Rat IV.	Rat V.	Rat VI.	Date.	Rat IV.	Rat V.	Rat VI.
May 26 . . . .	170	108	124	July 21 . . . .	154	104	111
June 2 . . . .	171	104	123	" 28 . . . .	150	100	105
" 9 . . . .	172	110	125	Aug. 4 . . . .	145	97	100
" 16 . . . .	165	100	118	" 11 <sup>1</sup> . . . .	135	95	95
" 23 . . . .	173	104	118	" 18 . . . .	...	93	94
" 30 . . . .	159	101	105	" 25 . . . .	...	86	83
July 7 . . . .	150	97	105	" 31 <sup>2</sup> . . . .	...	96	88
" 14 . . . .	151	99	104	Sept. 7 <sup>3</sup> . . . .	104	90	...
1 77 days			2 97 days.			3 104 days.	

Rat IV was in a feeble condition when killed. The other two were still apparently in good condition.

It is interesting to compare the behavior of the rats in this experiment with those of Falta and Nöggerath<sup>31</sup> and Jacob,<sup>32</sup> which were fed with similar rations, but with no care to induce a good consumption of food by constant change in the flavor of the ration. Their rats lost weight regularly from the beginning of the experiment. In the experiment of Jacob a rat weighing 193 gm. lost on an average 11.6 gm. per week and died at the end of the sixth week. Another, weighing 190, lost on an average 7.7 gm. per week, dying after eleven weeks. The third, weighing 162 gm., lost only 3.6 gm. per week, and died only after seventeen weeks.

<sup>31</sup> FALTA and NÖGGERATH: Beiträge zur chemischen Physiologie und Pathologie, 1905, vii, p. 313.

<sup>32</sup> L. JACOB: Zeitschrift für Biologie, 1906, xlviii, p. 19.

In Falta and Nöggerath's experiment in one instance a rat of 170 gm., or about two-thirds grown, was 10 gm. heavier at the end of four weeks than at the beginning of the experiment. Thereafter it lost weight steadily. All of their other rats were nearly full-grown animals.

It is very suggestive that in the experience of these authors those animals which were young and had not attained their growth withstood the artificial and unpalatable ration much better than did adults.

In the case of my own experiment Rat V, having the smallest initial weight, did better in maintaining its body weight than did the other two. In this case no decided loss of weight began until August 1, after the animal had been on the artificial ration sixty-six days.

In all of these rats the increased palatability of the ration deferred for some time the decrease in their body weight.

Lot II of this experiment were fed the same ration as Lot I, and the same precautions were taken in both experiments to secure the consumption of food. In addition, however, they received purine bases prepared from liver, and also lean beef, which was hydrolyzed with 15 per cent  $H_2SO_4$  until the biuret reaction disappeared. It is fair to assume that the phosphorus in this product was reduced to inorganic forms. It was thought that this mixture of amino acids might be efficient in rendering the taste of the food more pleasant. It was given only in small amounts and at irregular intervals to aid in relieving the monotony of the ration.

The record of these animals is shown in Table II.

Rat VIII lost during the experiment, covering one hundred and six days, 27 gm., or 20.76 per cent of its body weight.

Rat IX lost 28 gm. during the same period, or 26.41 per cent of its body weight.

It is again apparent that, by adding to the palatability of the food, the time at which the steady loss of weight began was deferred to about the fiftieth day in the case of Rat IX and to about the sixtieth day in the case of Rat VIII.

Rats VIII and IX were still in a fairly good condition at the end of the experiment, but it was evident here, as in the case of Lot I, that if kept on this food the animals would die after a few weeks more. They were therefore killed for analysis.

Rat VII was a remarkable individual. She ate the rations



offered her with unusual persistence, and as her record shows made an actual gain in body weight of 23 gm. in fifty-three days. It was thought desirable to find how much influence the complete removal of phosphorus in any form from the ration would have on her subsequent behavior. As will be seen from the record, her decline was steady and rapid after this change.

TABLE II.

LOT II. RECEIVED THE INORGANIC PHOSPHORUS RATION TOGETHER WITH PURINE BASES AND AMINO ACID MIXTURE FROM THE HYDROLYSIS OF BEEF MUSCLE.

Date.	Rat VII.	Rat VIII.	Rat IX.	Date.	Rat VII	Rat VIII.	Rat IX.
May 23 . . .	...	130	106	July 21 . . . .	180	129	97
" 26 . . .	...	122	99	" 28 . . . .	170	123	95
June 2 . . .	...	124	104	Aug. 4 . . . .	176 <sup>1</sup>	119	90
" 9 . . .	...	130	90	" 11 . . . .	169	117	88
" 12 . . .	153	...	...	" 18 . . . .	163	111	85
" 16 . . .	...	124	104	" 25 . . . .	158	103	87
" 23 . . .	168	135	92	Sept. 2 . . . .	...	100	80
" 30 . . .	168	124	93	" 5 . . . .	102 <sup>2</sup>	...	...
July 7 . . .	164	118	96	" 6 . . . .	...	103 <sup>3</sup>	78 <sup>3</sup>
" 14 . . .	175	128	99	....	...	...	...

<sup>1</sup> 53 days. All phosphorus left out of the ration from this time on.  
<sup>2</sup> Died. 32 days. <sup>3</sup> 106 days.

From the experiment with Lot II it is evident that in two cases the addition of purines and of the cleavage products of meat showed no appreciable improvement in the condition of the animals.

In the case of Rat VII, while it did much better than any other rat in the experiment described, it is questionable whether the purines and meat cleavage products were responsible for her unusual behavior, as will appear later.

The experience thus gained led to the belief that further experiments with still younger animals might give yet more satisfactory results.

Three young white rats weighing from 35 to 46 gm. were used in this experiment. The ration was the same as was used with Lot I and the methods of feeding were the same. Table III shows the record of these animals on this ration.

TABLE III.

RECORD OF VERY YOUNG RATS ON A RATION SUPPLYING ONLY INORGANIC PHOSPHORUS AND NO PURINES.

Date.	Rat XVIII.	Rat XIX.	Date.	Rat XVIII.	Rat XX.
Aug. 3 . . . . .	37	35	Oct 27 . . . . .	54	...
" 11 . . . . .	34	31	Nov. 3 . . . . .	56	...
" 18 . . . . .	42	37	" 10 . . . . .	62	...
" 25 . . . . .	39	33	" 17 . . . . .	60	46
Sept. 2 . . . . .	40	35	" 24 . . . . .	66	46
" 10 . . . . .	42	39	Dec. 1 . . . . .	73	49
" 17 . . . . .	48	40	" 8 . . . . .	76 <sup>2</sup>	50
" 28 . . . . .	49	41 <sup>1</sup>	" 15 . . . . .	...	59
Oct. 6 . . . . .	51	...	" 21 . . . . .	...	54
" 13 . . . . .	48	...	Jan. 5 . . . . .	...	58
" 20 . . . . .	50	...	" 12 . . . . .	...	60 <sup>3</sup>
<sup>1</sup> 56 days.		<sup>2</sup> 127 days.		<sup>3</sup> 56 days.	

Rat XVIII gained in one hundred and twenty-seven days 39 gm., or 105 per cent.

Rat XIX gained 6 gm. in fifty-six days, or 17.1 per cent. This rat was killed by accident, the lid of the cage falling upon it.

Rat XX gained 14 gm., or 30.4 per cent of its body weight in fifty-six days.

For the purpose of comparison a control experiment was made in which a phosphorized protein was contained in the ration. Two young rats were fed the same ration as Lot I, except that in place of calcium phosphate, casein was given. The casein was prepared fresh before each feeding by precipitating separator skim milk with acetic acid, straining and washing, then dissolving the curd in am-

monia and reprecipitating with acid. The casein was always mixed with the other food and was given in a perfectly fresh condition. Ash of milk was given with this ration. Casein was not given every day, but usually at intervals of two or three days, the same methods being used as in former experiments to give variety to the ration. No purines, hydrolyzed meat, nor commercial flavors were given, since it was not desired to introduce the two first-mentioned substances, and a satisfactory intake of food was secured without the latter. The results are shown in Table IV.

TABLE IV.

RECORDS OF RATS FED ON INORGANIC PHOSPHORUS RATION USED WITH LOT I, AND CASEIN.

Date.	Rat XV.	Rat XVI.	Date.	Rat XV.	Rat XVI.
Sept. 28 . . . .	87	83	Nov. 10 . . . .	103	95
Oct. 6 . . . .	86	77	" 17 . . . .	108	103
" 13 . . . .	90	80	" 24 . . . .	108	103
" 20 . . . .	87	78	Dec. 1 . . . .	111	102
" 27 . . . .	95	87	" 8 . . . .	107	101
Nov. 3 . . . .	93	85	" 15 <sup>1</sup> . . . .	106	100
<sup>1</sup> 78 days.					

The experiment was broken off at this date, the rats being in a healthy and normal condition.

For purposes of comparison the rate of growth of normally fed rats, receiving a ration of corn, wheat, and rolled oats, the following table is included.

In order to determine whether the period in the life of the animal is an important factor in relation to maintenance with a ration such as was used in these experiments, a single full-grown rat was placed in a separate cage and given the same ration and care that was given Lot I. His attitude toward the ration is shown by the record of his weight during a period of thirty-three days:

Date.	Weight of rat
Oct. 7 . . . . .	233 gm.
Oct. 13 . . . . .	215 "
Oct. 25 . . . . .	222 "
Nov. 3 . . . . .	204 "
Nov. 10 . . . . .	195 "

The experiment was discontinued. When the animal was placed on a corn, wheat, and rolled oat ration, it speedily recovered its weight. He would not eat a sufficient quantity of the artificially prepared ration to supply his energy requirement.

TABLE V.

RECORD OF THE RATE OF GROWTH OF RATS FED CORN, WHEAT, AND ROLLED OATS.

Date.	Rat I.	Rat II.	Rat III.	Date.	Rat I.	Rat II.
May 26 . . .	172	135	103	July 14 . . .	241	212
June 2 . . .	200	158	125	" 21 . . .	245	222
" 9 . . .	207	167	156	" 28 . . .	248	228
" 16 . . .	223	187	138	Aug. 4 . . .	...	...
" 23 . . .	231	196	153	" 11 . . .	...	...
" 30 . . .	233	200	176 <sup>1</sup>	" 18 . . .	255	250
July 7 . . .	240	203	...	.....	...	...

<sup>1</sup> Had young and the record was discontinued.

In order to throw additional light on the subject of nucleic metabolism it was desired to obtain data showing the actual amount of phosphorus excreted per day when a phosphorus free ration was taken. That this is not necessarily the same as the phosphorus excreted during starvation is the opinion of Gevaerts,<sup>33</sup> who found that in rats when fed a ration containing no phosphorus the ratio of phosphorus to nitrogen excreted fell to about one tenth of the value during starvation. In order to obtain more data on this important question, Rat VII, whose record is shown in Table II, was

<sup>33</sup> GEVAERTS: *La cellule*, 1901, xviii, p. 7.

placed in an inverted bell jar having a hole in the centre of the dome. A screen formed a floor on which the rat could stand and move about. Asbestos, thoroughly extracted with hot nitric acid, was spread over this screen to serve as a bed. Each day the rat was removed and the bottom of the bell jar washed with a small sponge, the washings being collected in a large dish placed below. The screen floor was washed after removing the asbestos and the latter placed in the dish with the washings. Fresh dry asbestos was placed on the screen and the rat replaced in the jar. The washings and asbestos bed were then acidified strongly with nitric acid, then boiled, and the whole transferred to a suction filter, and the asbestos washed free from phosphorus. The washings were then concentrated, sulphuric acid added, and the solution transferred to a flask, and all organic matter destroyed by oxidizing with nitric acid according to the Neumann method. Phosphoric acid was determined by precipitating with ammonium molybdate in nitric acid solution and was weighed as magnesium pyrophosphate. The phosphorus excreted is shown in Table VI. This experiment was begun on August 25 and continued eight days.

TABLE VI.

Day	Phosphorus excreted
1 . . . . .	0.0085
2 . . . . .	0.0084
3 . . . . .	0.0076
4 and 5 . . . . .	0.0114
6 . . . . .	0.0089
7 . . . . .	0.0012
8 . . . . .	0.0051
Total . . . . .	<u>0.0511</u>
Average . . . . .	0.0063

The ration given during this period consisted of zein, edestin, starch, sugar, and butter fat. The ash constituents given were magnesium oxide, calcium sulphate, potassium chloride, sodium carbonate, sodium chloride, and ferric chloride.

It is not possible to say how much the rat was eating during the days of this experiment, but it is known that some food was taken each day.

Gevaerts<sup>34</sup> found for starving rats an excretion of phosphorus

<sup>34</sup> GEVAERTS: *La cellule*, 1901, xviii, p. 7.

in an animal weighing 210 gm., amounting to 0.007 to 0.0114 gm. per day. In another experiment the amounts were 0.0086 to 0.0184 gm. per day. When phosphorus free edestin and cane sugar were fed, Gevaerts observed an excretion of only 0.001 to 0.004 gm. of phosphorus per day for rats weighing 180 to 200 gm.

In a second trial with a rat weighing 217 gm. the writer starved it for four days, then fed edestin and cane sugar for a period of four days. The excreta were collected together for the entire period, and the phosphorus amounted to 0.017 gm., or 0.0043 gm. per day.

The phosphorus was determined in the entire bodies of nine rats (exclusive of the skeletons) by boiling the rats after opening and carefully cleaning the stomach and intestines and removing the skeleton, great care being taken to remove the small bones of the feet. The tissues and water in which the rat was boiled were evaporated to dryness, dried in an oven, ground, and sampled. Analysis of the dry tissues of nine individuals, including all rats in Tables I and II, and three normally fed ones, calculated on the basis of the live weight less the weight of the skeleton, showed an average phosphorus content of the body of the skeleton free living rat to be 0.19 per cent (P). This furnishes interesting data for calculation. If a rat weighing 200 gm. excrete 0.005 gm. phosphorus per day, since his body would contain 0.38 gm. of this element, in the course of seventy-six days the entire content of phosphorus in his body would change. Since of the three rats in Tables I and II, which were continued beyond one hundred days, the loss of body weight was 16.66, 20.76, and 26.41 per cent respectively (average 21.27 per cent), even in these experiments it would seem incontrovertible that the animals were utilizing the inorganic phosphorus supplied for nuclein and phosphatide formation. This is all the more convincing when the weights of the skeletons of these animals are taken into account. The abnormally large skeletons found in those animals receiving a large supply of inorganic phosphates is strikingly evident, even though the body weight did not increase. They were not, therefore, drawing phosphorus from this source. This is in harmony with the observations of Hart, McCollum, and Fuller with pigs.

Even admitting Gevaerts' lowest figure, 0.001 gm. per day, a 100 gm. rat, containing 0.19 gm. of phosphorus in its soft tissues, would metabolize 53 per cent of this during one hundred days. This

is not in harmony with a loss of 16 to 20 per cent of body weight in the same time.

As a possible explanation of the results here presented, it might be urged that the gains in weight observed were due to an excessive deposition of fat or an undue accumulation of fluids in the body, as sometimes occurs as a pathological condition; the animals used were accordingly in most cases subjected to the following analyses: The weight of the animal at the time of death was ascertained. It was then boiled with water until thoroughly cooked, when the skeleton was completely removed from the tissues. The tissues and water in which the rat was boiled were united, and the whole evaporated on the water bath to dryness. The dry tissues (less the skeleton) were then dried in an oven at 100° C. for several days, carefully scraped from the dish, ground, weighed, and placed in a bottle. The skeleton was dried in an oven at 100° C. and weighed, and afterward ignited to a nearly white ash in a muffle. The weight of the ash was obtained.

The fat in the dry tissues was extracted with ether for twenty-four hours, then the tissues were ground a second time, and again extracted twelve hours. While this does not give the total fat of the tissues, it is believed to represent nearly all of the fat deposited as such and not the invisible fat of the organs and tissues. The tissues thus extracted were weighed, and the weight taken as fat-free tissue. The data thus obtained for all the rats analyzed is given in Table VII.

The data presented in Table VII show that while the ratio of fat-free tissues to body weight varies considerably in individuals, as would be expected, this variation does not point to an abnormal composition of the body of any individual examined.

The fat content and muscle and organ content of the experimental animals must be considered normal. Hence the gains in weight in the case of Rats VII and XVIII are to be taken as proof of an actual increase of muscle tissue and of organ tissue. This is true also for Rats XIX and XX, in which a fair gain in body weight was observed.

That the composition of the organs and tissues with respect to phosphorus, calcium, and moisture is always maintained normal is shown by the data furnished by Hart, McCollum, and Fuller in their analysis of pigs' tissues. That the composition of the tissues with respect to other constituents is also normal cannot be doubted.

TABLE VII.  
SHOWING THE COMPOSITION OF RATS USED IN EXPERIMENTS WITH VARIOUS RATIONS.

Ration.	Number of rat.	Weight. gm.	Skeleton. gm.	Dry tissues less skeleton. gm.	Either extract. gm.	Ash of skeleton. gm.	Skeleton Wt. of rat	Fat free tissues Wt. of rat
Normal . . . . .	I	147	6.67	38.0	8.89	3.79	4.54	19.8
Normal . . . . .	II	157	6.50	45.0	10.8	3.85	4.14	21.79
Normal . . . . .	X	34	1.33	9.5	3.25	.68	3.91	18.39
Inorganic phosphorus, later phosphorus free.	VII	102	7.14	25.5	3.42	4.49	7.0	21.64
Inorganic phosphorus .	IV	135	9.0	34.8	7.0	4.28	6.66	20.59
Inorganic phosphorus .	V	96	5.78	22.0	4.01	3.02	6.02	18.94
Inorganic phosphorus .	VI	88	7.50	20.5	3.63	3.18	8.52	19.17
Inorganic phosphorus .	VIII	103	6.03	21.5	2.67	3.52	5.85	18.28
Inorganic phosphorus .	IX	78	4.58	14.5	.86	2.77	5.79	17.49
Inorganic phosphorus .	XVIII	76	4.07	17.5	3.40	2.14	5.36	18.55



The per cent of phosphorus in the ash of the bones of all rats described in Table VII was found to be the same.

### CONCLUSIONS.

The data furnished by these experiments seem to warrant the following conclusions:

1. The palatability of the ration is a most important factor in animal nutrition. Without palatability the ration may possess all the necessary food ingredients and yet fail to properly nourish an animal.

2. The failure of previous efforts to maintain animals on a mixture of relatively pure proximate constituents of our food stuffs was due to the lack of palatability of such mixtures.

3. When sufficient care is given to changing the character and flavor of the food supplied in such simple mixtures, it is possible to induce an appreciable amount of growth.

4. Very young animals adapt themselves to a ration possessing a low degree of palatability much better than do adults.

5. That, other things being satisfactory, all the phosphorus needed by an animal, for skeleton, nuclein, or phosphatide formation, can be drawn from inorganic phosphates.

6. That the animal has the power to synthesize the purine bases necessary for its nuclein formation from some complexes contained in the protein molecule, and does not necessarily use purine bases of exogenous origin for this purpose.

## THE ELIMINATION OF BARIUM.

By GUSTAVE M. MEYER.

[From the Laboratory of Biological Chemistry of Columbia University, at the College of Physicians and Surgeons, New York.]

### INTRODUCTION.

OF the salts of the alkali earths, those of magnesium and calcium are the only ones which appear to be eliminated to an appreciable extent in the urine after their introduction into the animal body. In a paper by Meltzer and Lucas<sup>1</sup> the following remarks appear: "For the salts of these three [calcium, strontium, and barium] alkali earths it was variously established experimentally that no matter by what path introduced, they leave the body in far greater quantity by the bowel than in the urine. Magnesium, like calcium, is an alkali earth, and from the rule laid down by Mendel for this class of inorganic compounds it seems to follow that the salts of magnesium also leave the body in far greater quantity by the bowel than in the urine." For magnesium, however, it has been definitely shown that that element is excreted to a greater degree by way of the kidneys, whereas the channel of elimination of calcium is mainly through the intestines.<sup>2</sup>

Mendel<sup>3</sup> came to the conclusion that both strontium and barium are eliminated to a certain extent in the urine after their subcutaneous introduction. As was pointed out in a previous paper,<sup>4</sup> Mendel's deductions in this connection with regard to *barium* were based on a positive result obtained from but one sample of uncontami-

<sup>1</sup> MELTZER and LUCAS: Journal of experimental medicine, 1907, ix, p. 299.

<sup>2</sup> HEISS: Zeitschrift für Biologie, 1876, xii, p. 151; MÜLLER: *Ibid.*, 1884, xx, p. 334. See also ALBU and NITBERG: Physiologie und Pathologie des Mineralstoffwechsels, 1906, p. 129; and MENDEL and BENEDICT: This journal, 1909, xxv, p. 1.

<sup>3</sup> MENDEL and THACHER: This journal, 1904, xi, p. 5; MENDEL and SICHER: *Ibid.*, 1906, xvi, p. 147.

<sup>4</sup> MEYER: Journal of biological chemistry, 1907, ii, p. 474.

nated urine.<sup>5</sup> Mendel's conclusion that "Barium, introduced subcutaneously in the form of soluble chloride in non-lethal doses, is eliminated to a very small extent only by the kidneys, a detectable excretion through this channel ceasing within a few hours," is based entirely upon that single observation. There was also the surprising assumption in the paper by Mendel and Sicher, that *barium was presumably contained in a second sample of urine which had been lost before its barium content could be investigated.*

The fact that barium is eliminated in the *feces* under various conditions of administration was noted by Bary,<sup>6</sup> also by Neumann,<sup>7</sup> and more recently in this laboratory by Berg and Welker.<sup>8</sup> Mendel and Sicher have confirmed these observations. Our own results substantiate the statements in this regard by the above-mentioned authors.

With respect to the elimination of barium in the *urine*, reported observations are not entirely in accord. Bary, who was one of the first to study this element in this respect, stated that he found barium only once (the only time he looked for it?) in the urine of a dog after the subcutaneous injection of 10 mgm. of barium chlorid per kilo of body weight. Neumann claimed that he found barium in his own urine after taking 0.3 gm. of barium chlorid. He also detected barium in the urine of a dog after the administration of 0.1 gm. *per os*. The result obtained by Mendel and Sicher has already been mentioned. These appear to be the only records of detections of barium in urine. In two cases the barium was injected subcutaneously, in the others it was administered *per os*. Neumann cites instances in which the test for barium in the urine was negative. It is difficult to decide from the results in Bary's paper whether he tested more than one urine. The following is quoted from his dissertation:<sup>9</sup> "Ausser Untersuchung der Organe habe ich noch in *manchen* Fällen die Excrete des Thierkörpers untersucht und dabei *festgestellt* dass das Barium in dem Faeces wie im Urin erscheint. VIII, XV." In connection with his Experiment VIII Bary referred to the finding of barium in the feces, and in discussing his Experiment XV he mentioned the detection of barium in the urine.<sup>10</sup> Berg

<sup>5</sup> There were several *negative* results, however.

<sup>6</sup> BARY: Inaugural-Dissertation, Dorpat, 1888, p. 87.

<sup>7</sup> NEUMANN: Archiv für die gesammte Physiologie, 1885, xxxvi, p. 497.

<sup>8</sup> BERG and WELKER: Journal of biological chemistry, 1906, i, p. 390.

<sup>9</sup> BARY: *Loc. cit.*, p. 87.

<sup>10</sup> BARY did not state how he collected the urine, and there is a possibility of its having been contaminated with feces.

and Welker, in their study of the effect of injected barium bromid on metabolism, could not detect barium in an uncontaminated sample of urine. Mendel and Sicher reported, besides the positive test already referred to, negative results for barium on four samples of urine. The evidence seems to indicate that occasionally barium, whether given *per os* or subcutaneously injected, may be eliminated in the urine in minute amounts.

Studies of the elimination of radium,<sup>11</sup> an element closely allied to barium, have shown that this element, after its subcutaneous injection, is excreted in both feces and urine. The quantity of radium contained in the excreta could not be determined. The qualitative test for radium is, however, extremely delicate, far more delicate, indeed, than any which could be applied to the other elements of the group of alkali earths. On the basis of the similarity in chemical properties it was said:<sup>12</sup> "The results with radium suggest that if chemical methods for their identification were delicate enough, barium, calcium, and their metallic congeners could be detected in all parts of the organism after their administration, and would be found under such circumstances in practically all the excreta." Unfortunately no test is at present known for barium (not even the spectroscopic) which in any way equals the delicacy of the best methods for the detection of radium.

Bary realized this difficulty, and for that reason subjected to his test only those samples of organs and excreta in which he considered it probable that barium was present. Bary dried the material and then charred it. After extracting the charred mass with water and filtering, he tested this filtrate for barium. He therefore took no account of the barium which might have been present at the start in an insoluble condition. By this method of procedure he could not detect less than 1.5 mgm. when added to 200 c.c. of urine.

We are still dependent on essentially the same tests for barium that were in use at the time Bary made his observations, and any desirable modification of the said methods involves primarily the procedures dealing with the destruction of the organic matter and the conversion of all the barium into a soluble form. A study of the elimination of barium must therefore deal with the question whether it is eliminated in such amounts as may be detected by the usual

<sup>1</sup> MEYER: *Journal of biological chemistry*, 1906, ii, p. 461.

<sup>2</sup> MEYER: *Ibid.*, p. 478.

chemical means, instead of considering its presence in the excreta in infinitesimal quantities.

#### EXPERIMENTAL.

The method of procedure which was employed in these experiments, and which will be described below, allowed the ready detection of 0.5 mgm. of barium bromid (0.2 mgm. of barium) after its addition to 360 c.c. of urine. As the animals were given subcutaneously from about 0.2 to 0.5 gm. of barium bromid at a time, a negative test in the urine of such animals indicated, as a rule, that less than one four-hundredth part of the amount introduced had been excreted — which is equivalent to practically no elimination. As has already been suggested, the question was not whether *some* barium was excreted by the kidneys, but whether barium was eliminated in the urine in *measurable quantities*. There is reason to believe that *all* elements, after their introduction into the body, are eliminated, to some extent at least, in the urine as well as in the feces. The quantities therein contained, however, may not be within the possibilities of detection by known methods for their identification.

All tests described below failed to show the presence of barium in uncontaminated urines of dogs which had been given barium bromid or chlorid subcutaneously in non-lethal or in lethal doses. A very small amount of barium was found in the urine of dogs which received barium *per os*. The quantity of barium in such urine was, however, only the merest fraction ( $\frac{1}{10000}$  to  $\frac{1}{5000}$ ) of the amount thus administered. The elimination of barium in the urine, no matter in what manner administered, is a negligible quantity. The bowel is the main channel for the excretion of this element.

A definite relationship seems to exist in this connection in the behavior of the alkali earths.<sup>13</sup> Magnesium, as has been shown, is the one for which the kidneys are the main path of excretion. Then in degrees of elimination in the urine the other elements — calcium, strontium, and barium — follow in their chemical periodic order. Barium is passed into the urine in very minute amounts, and then only in quantities hardly detectable by chemical means, even when administered in fairly large doses internally. Calcium and stron-

<sup>13</sup> They are eliminated proportionately in the *urine* in the *inverse* order, and in the *feces* in the *direct* order, of their atomic weights.

tium stand between, but in the case of calcium we find that it is excreted in greater proportion by the intestines than by the kidneys. Radium, which follows barium in the periodic system, also fits into the above order. Absolute figures for radium elimination are not obtainable, but experiments reported from this laboratory have shown that, after the subcutaneous injection of radium bromid, the feces contain this element as soon as and also long after the simultaneously excreted urine has ceased to manifest radio-activity.

Beryllium belongs to the group of alkali earth metals. So little is known regarding the paths of excretion of this element that no definite conclusions can be drawn regarding it in this connection.<sup>14</sup>

**Method of analysis.** — The destruction of the organic matter in the urine or feces was carried out according to the directions of Noyes and Bray.<sup>15</sup> The material was evaporated to dryness in a casserole and treated with equal parts of concentrated sulfuric and nitric acids on a water bath and finally over a free flame until the decomposition was complete. The liquid was then evaporated to a very small volume and, after subsequent dilution with water, was filtered through a Baker and Adams paper (12½ cm., weight of ash 0.00007 mgm.). The paper was incinerated in a platinum crucible and the ash fused with a mixture of equal parts of dry sodium and potassium carbonates, in order to convert the barium sulfate to carbonate. The fused mass was extracted with water, and the insoluble carbonate collected on a 10 cm. Baker and Adams filter paper. After thorough washing with water the carbonates were dissolved on the paper in 10 c.c. of warm dilute hydrochloric acid and allowed to filter into a perfectly clean test tube. The presence of barium in this filtrate was determined after heating to boiling point by the addition of 5 c.c. of half-saturated calcium sulfate solution.

Noyes and Bray suggest boiling of the insoluble sulfates with a saturated solution of sodium carbonate. This, however, is not sufficiently delicate for the detection of less than 1 mgm. of barium. By following the directions of Noyes and Bray down to the conversion of the sulfates to carbonates and then falling back upon the fusion method, it is possible readily to detect the presence of 0.5 mgm. of added barium bromid (0.2 mgm. of barium) in 360 c.c. of urine.

<sup>14</sup> Only one study of this element appears to have been reported (SEIMS, Inaugural-Dissertation, Dorpat, 1886). Steps have already been taken in this laboratory to study this element in this regard.

<sup>15</sup> NOYES and BRAY: *Journal of the American Chemical Society*, 1906, xxix, p. 144.

**Animals; method of injection, etc.** — Dogs were used exclusively in these experiments. In the first series (I–IV) the experiments of Mendel and Sicher were repeated. A second series (V–VI) was carried out on dogs having esophageal fistulas, in order to exclude from the alimentary tract the barium secreted in the saliva.<sup>16</sup> In an animal with an esophageal fistula the subcutaneous introduction of barium is more strictly parenteral. It is possible, of course, that in such cases barium enters the intestine by other secretory channels, *e. g.*, in the bile (see protocol III).

Finally an experiment was also carried out to determine the presence of barium in the urine after the administration of barium *per os*.

The subcutaneous injections were made with special care to prevent external loss of solution. The skin at the place of injection was shaved and cleansed, and before injection was washed with alcohol. The barium salt was dissolved in the requisite amount of distilled water to make solutions of approximately 0.5 per cent barium bromid. Barium bromid was used in place of the chlorid in all but one instance (V), as a product of special purity of Kahlbaum's make was available in this laboratory. It is well known, of course, that the anion is of little consequence in experiments of this nature and would not appreciably influence the excretion of the cation connected with it.

Special precautions were taken in the collection of the urine. Any sample of it that was believed to be contaminated with feces was rejected. The animals with the fistulas, and also the one that received barium *per os*, were catheterized at intervals of four hours.

The presence of barium in the feces, under the conditions of these experiments, having been repeatedly established, only occasional samples of feces were subjected to analysis, but special attention was given to the occurrence of barium in the urine. The feces of the dogs with esophageal fistulas were not analyzed, as they could not be obtained uncontaminated with saliva that dripped to the bottom of the cage.

The dogs, with the exception of those having the esophageal fistulas, were fed a diet of meat, cracker meal, and lard, with a generous amount of water. Bone ash was omitted on account of its high phosphate and calcium contents. The diet and manner of feed-

<sup>16</sup> NEUMANN: *Loc. cit.*, p. 480.

ing the "fistula dogs" is indicated in the respective protocols (V and VI).

**Protocols.** — I. A dog weighing 13.4 kg. received a subcutaneous injection of 165.7 mgm. of barium bromid (5.09 mgm. of barium per kilo of body weight). During the following three days four samples of uncontaminated urine were collected. Two samples of feces were analyzed.

II. A. The same dog three days later received an injection of 289.6 mgm. of barium bromid (8.9 mgm. of barium per kilo). A total of 684 c.c. of uncontaminated urine was submitted to analysis. B. The injection was repeated after three days, 364.5 mgm. of barium bromid (15 mgm. of barium per kilo) having been introduced. No urine was excreted after this injection, — none could be obtained by catheterization. The dog succumbed rapidly to the effects of the barium and died eight hours after the injection. The bladder was empty. Two samples of feces were submitted to analysis.

*The analytic results of Experiments I and II A showed the presence of barium in each sample of feces and its absence from all samples of urine.*

III. A bitch weighing 9.85 kg. received a subcutaneous injection of 526.7 mgm. of barium bromid (22 mgm. of barium per kilo). Three hours after injection, uncontaminated urine was obtained. The dog vomited two hours later and had profuse diarrhea. Death ensued shortly after.

*The feces and uncontaminated vomit gave positive results in the tests for barium. Barium was not found in the urine.*

IV. A dog weighing 9.15 kg. received a subcutaneous injection of 91.5 mgm. of barium bromid (4.13 mgm. of barium per kilo). The dose of barium bromid was repeated on each of the two succeeding days. On the eighth day 185 mgm. of barium bromid were subcutaneously administered. The following day death occurred.

*Two samples of feces, taken on the first and second days, gave positive results in the tests for barium.*

*Five uncontaminated samples of urine collected on the first, second, third, tenth, and eleventh days gave negative responses to the tests for barium.*

V. A dog weighing 14 kg. was operated on for an esophageal fistula. The operation was performed under ether anesthesia and with the usual aseptic precautions. The esophagus was divided a short distance below the larynx. The lower segment of the esophagus was brought out laterally and secured in such a manner that the orifice appeared externally next to the sternocleidomastoid muscle. The upper end of the esophagus was secured externally in the median line. The dog was fed by means of a stomach tube inserted in the lower esophageal opening. As no solid food could be given, the daily diet consisted of 500 c.c. (later 750 c.c.) of



milk, in which was dissolved enough dried milk<sup>17</sup> to about double the content of solids in the milk. The dog was allowed to drink water from time to time, and some was also given internally several times a day.

One week after the operations, the wound having healed and the fistula being in sound condition, the dog received subcutaneously 70 mgm. of barium chlorid (2.8 mgm. of barium per kilo). In order to increase the amount of urine, 250 c.c. of water were passed into the stomach. On the third day the dog received a subcutaneous injection of 100 mgm. of barium chlorid (4 mgm. of barium per kilo). The following day 150 mgm. of barium chlorid (6 mgm. of barium per kilo) were given; three days later, 200 mgm. (8 mgm. of barium per kilo), and the day after, 300 mgm. (12 mgm. of barium per kilo). The last administration caused a rapid decline. After speedily obtaining a sample of urine, the animal's sufferings were at once relieved with morphine and death ensued in a short time.

*Urine was taken at intervals of four hours by catheterization. None of the eight samples contained detectable traces of barium.*

VI. A bitch, weighing 7.2 kg., was operated on for an esophageal fistula as in the case of the animal in Experiment V. Five days after the operation the dog received subcutaneously 300 mgm. of barium bromid (17 mgm. of barium per kilo) and 250 c.c. of water into the stomach. Only one sample of urine was obtainable before the toxic effect of the barium became pronounced. The dog died within twenty-four hours. The bladder was empty.

*The urine was free from a detectable trace of barium.*

VII. A dog weighing 7.4 kg. was given barium bromid *per os* as follows: first day, 100 mgm.; second day, 200 mgm.; third day, 500 mgm. (28 mgm. of barium per kilo); sixth day, 500 mgm.; and seventh day, 500 mgm.

*The total volume of urine passed on the second day (150 c.c.) contained an imponderable trace of barium. That the slight amount of precipitate obtained with calcium sulfate contained barium, was confirmed with the spectroscope. The combined urines of the sixth and seventh days also contained a small amount of barium.*

#### SUMMARY OF GENERAL CONCLUSIONS.

1. After its introduction into the animal body parenterally, in moderate amounts, barium is not eliminated into the urine in quantities that can be detected chemically in ordinary fractions.

<sup>17</sup> Two kinds were used and found to give good results: MERREL and SOULES' "True milk" and "Diet milk" obtained from the Dry Milk Co.

2. When barium is administered by mouth in relatively large amounts, only a trivial fraction of it appears in the urine.

3. Our results, in accord with observations by other investigators, demonstrate that the bowel is the main channel of elimination for barium.

I desire to express my thanks to Dr. William J. Gies for the interest he has shown in this investigation.

# THE NEUROCYTOLOGICAL REACTION IN MUSCULAR EXERTION.

## I. PRELIMINARY COMMUNICATION. THE SEQUENCE OF THE IMMEDIATE CHANGES IN THE PURKINJE CELLS.

By DAVID H. DOLLEY.

[From the Pathological Laboratory of the University of North Carolina.]

### SYNOPSIS.

Introduction. — The corroboration of previous deductions regarding anemia and shock . . . . .	151
Source of material . . . . .	153
Microscopic technic . . . . .	154
The sequence of the morphological alterations resulting from work and over-work . . . . .	155
The results of differential counts of types of cells . . . . .	165
Summary . . . . .	170

### INTRODUCTION.

AS a result of previous studies,<sup>1</sup> on the reactions of nerve cells in experimental states of anemia and shock, the conception was reached that the definite, constant, and orderly sequence of changes which occur is a manifestation of functional activity. The changes are regarded as pathological only in the sense of a physiological aberration, the logical outcome of activities carried to their ultimate limit. Theoretically, this conception is supported by the character of the essential physiological factor common to both conditions which affects the nerve cell primarily. This is stimulation, artificial and mechanical in the case of shock, natural and metabolic in the case of anemia. As a result, work and over-work

<sup>1</sup> DOLLEY: Journal of medical research, 1909, xx, p. 275; *Ibid.*, 1909, xxi, p. 95.

ensue. The response of the cell is essentially from within in a display of its activities, and the coincident or ensuing alteration of the environment plays only a subsidiary rôle in other respects in hastening the culmination. However strong the chain of argument may appear to be, it rests only upon the insecure basis of the present status of neuro-physiological knowledge. The belief in the truth of the conception is based upon the firmer support of the nature of the morphological alterations. The application of well-established cytological doctrines to the nerve cell has afforded consistent results. The nucleus-plasma relation theory of Richard Hertwig and the doctrine of chromidial apparatus of Richard Goldschmidt find here a further exemplification. Starting from the basis of the conformity with the accumulated mass of cytological information due to them and their co-workers, the meaning of the sequence of changes which is to be followed in nerve cells is only to be interpreted as having the same significance of capacity for function or the result of function.

However, as the ideas were evolved from the study of pathological conditions in the ordinary acceptation of the term, the necessity of strengthening them by their extension to include purely physiological states was apparent. For this reason the present more fundamental and physiological line of research was conceived. The reaction to the physiological states to be described is identical with that previously described for shock and anemia as types of pathological processes. It is a process, and the process is one and the same. A preparation from a profoundly fatigued dog is not to be distinguished from a profoundly shocked or anemic one.

The work of Hodge, Mann, Lugaro, and others on the effect of physiological activity and artificial stimulation was discussed in the second paper, and the general similarity of their results pointed out. No further review, therefore, seems necessary in the present connection. It is purposed, however, at some future time to review the literature on the allied pathological conditions, particularly anemia, and to attempt to explain and harmonize the somewhat varying findings in the light of a definite, purposeful process. For example, the resistance of the karyosome, about which there is general uniformity of opinion, is clearly explained. Again, the question whether chromatolysis is central or peripheral admits of solution if the manner of the renewal of the extra-nuclear chromatic material from the nucleus in its successive stages be accepted.

#### SOURCE OF MATERIAL.

This article is based upon the study of seven dogs which were exercised in a treadmill. The apparatus consisted of a wheel-like box, 3 feet in diameter and about 7 inches in width, fitted on each side with an axle to revolve between two supports and turned by hand with a crank. The walking surface of the rim was carpeted, and the sides were covered with wire netting. The distance traversed was not nearly so important a factor as the manner of traversing it. For example, the thirty-minute dog was estimated to have walked but slightly over a mile. By backing away from the direction they were compelled to take, the effect was that of walking down a steep incline.

For obtaining comparative material from normal, active, and fatigued states, a litter of four hound puppies, in excellent condition and about five months old, was used. The weight of three of them varied between  $5\frac{1}{2}$  and 6 kilograms, while the fourth, which was exercised the longest, weighed 7 kilograms. One of them, previously undisturbed, was chosen as a control (Experiment 5). The others were exercised fifteen minutes (Experiment 6), thirty minutes (Experiment 4), and one hour (Experiment 3) respectively. To grade their activities as far as possible, each one was exercised for nearly the same proportionate time, about three fourths of its total, and the remaining one fourth was distributed as periods of rest. It was not possible to do this with entire uniformity, but it was approximated as closely as the individual variations in the animals would permit.

The other animals, all stout young adult dogs, were carried to a state of considerable exhaustion. Individual variations in the animals and experimental variations in the rate of movement and in the amount of rest prevent grading them with exactness. In the first two experiments the animals were worked rather hard at first with short and irregular periods of rest, then at longer and longer intervals with the progressive requirement for rest, and finally were left undisturbed for some time before being killed (four hours in the case of Experiment 1 and two hours in Experiment 2). The time was not taken throughout the initial experiment, but the second lasted nearly six hours altogether. The third dog (Experiment 7) showed decidedly the effect of longer and more frequent periods of rest in a

course of nearly eight hours with no rest immediately prior to killing. During this time, with alternating three-minute intervals of work and rest, only two long periods of rest were indicated. At no time were the experiments pushed to unnecessary lengths, and the manner of response on the part of the animal regulated the periods of rest as well as the total duration. The question of recovery in both the milder and the severer states will be considered in further work, which is in contemplation to determine the power of recuperation.

With the exception of the first two animals, which were anesthetized with ether, the dogs were killed by shooting through the heart. This was done to obviate any possible effect of the anesthetic, though, in the amount required for the purpose, this would appear to be a negligible factor. The skull was opened as rapidly as possible, and in every case after death by shooting the cerebellar tissue, which was routinely chosen first, was in the fixing fluids in an average of six minutes.

The present article deals only with the Purkinje cells of the cerebellum. In the first place, the main object is to co-ordinate the natural processes here considered with the abnormal states of shock and anemia previously discussed for the same cells. Secondly, it is thought that the exploitation so far as possible of a single type of cell is advisable before advancing to the detailed study of others. Only thereby can a definite idea be obtained of what to expect in others more difficult of approach and probably in greater part less subject to extreme upset of their intracellular co-ordination. Furthermore, the rank of the cerebellum in the nervous economy makes a clear idea of its cellular processes of first importance. Tissue from three parts of the organ is here considered, from the worm, the uvula, and the biventral lobe.

#### MICROSCOPIC TECHNIQUE.

The technical procedures have been identical with those in preceding work. In brief, fixation was controlled by the use of three fluids, 96 per cent alcohol, picro-sulphuric acid, and saturated corrosive sublimate in 10 per cent formalin. While some of the most satisfactory preparations have been obtained from the picro-sulphuric material, the conviction is growing that different stocks made from the same raw materials are inconstant in their action. For routine

work, Held's modification of the Nissl stain for the alcohol and picro-sulphuric material and Grenacher's borax-carminic in bulk after the sublimate fixation have been employed. The corrosive formalin tissue thus stained has proven invaluable, for the preparations are so obviously free from the defects resulting from the cruder methods. Not only is this so, but the technic of staining in bulk with differentiation in acid-alcohol is a fixed quantity, in which over-staining and over-differentiation are self-controlled. It is true that the pictures are faint as compared with the intense methylene blue stain, but after some experience it permits the same differentiation of stages and indeed in certain early ones it has aided in a finer separation.

#### THE SEQUENCE OF THE MORPHOLOGICAL ALTERATIONS RESULTING FROM WORK AND OVER-WORK.

The comparative study of the experiments on the puppies has afforded a finer differentiation of the earlier stages of the process which was not attempted in previous work on account of the severity and extent of the involvement in the majority of the experiments studied and the difficulty of grading milder ones with accuracy. It is evident that under a steady strain the earliest stages of functional activity are passed through rather rapidly. However, the gross differentiation offered in the second communication has been substantiated so far as it went, and the exact identity of the process is definite.

In making the division into stages, the fundamental principles have been to consider that the variations in staining reaction, in the size, shape, and structure of both cell body and nucleus, and in the ratio of the size of the nucleus to that of the cell body, which by their combinations make up the varied types of cells, all mean something and to interpret them as divisions of a purposeful process in the light of well-established biological theories. The idea of purpose held throughout is the basis of the claim for logical interpretation. Of the cellular constituents, the reaction on the part of the basic chromatic material, intra-nuclear and extra-nuclear, is of first importance.

The relationship which exists between the intra-nuclear and the extra-nuclear basic chromatic material was initially set forth by

Richard Hertwig<sup>2</sup> in a generalization for protozoa. A further extension to other cells has been made by Howard and Schultz in their work on "The general biology of tumor cells," which is forthcoming in the "Journal of experimental medicine." My thanks are due to them for the privilege of reading their manuscript. Hertwig's idea, to borrow their form of expression, is that "the material from which chromatin is derived is formed in the cytoplasm and exists there without characteristic staining reaction. This 'prochromatin' is taken up by the nucleus and by means of the acid-staining nucleolar substance is organized into chromatin and thereby becomes visualized. From the nucleus, chromatin and its derivatives return to the cytoplasm to be used in the vegetative functions of the cell. The chromatin would seem to be an unstainable material derived from the cytoplasm plus nucleolar substance." The essential idea of the conception is the interdependence and the constant interchange between cytoplasm and nucleus.

In the case of nerve cells, Goldschmidt<sup>3</sup> first suggested from their staining reaction and the analogy with certain protozoan and egg cells that they belong to a special class in possessing in the Nissl substance what he terms chromidial apparatus. By such apparatus he means an extra-nuclear, functioning, nuclear material. The experimental lines of research of the writer afford additional evidence, more particularly in the stages of exhaustion of the cell, of the nuclear origin of the Nissl substance. The extra-nuclear chromatic material is used up and successively replaced from the nucleus in definite stages. Finally, the integrity of the karyosome is affected, and with the giving up to the cytoplasm of its final quota, and the using up of this ultimate supply, the cell becomes devoid of chromatic material. The developmental origin of the Nissl substance from the nucleus deduced by Scott<sup>4</sup> strongly substantiates the correctness of the conception. Nerve cells, therefore, with their chromidial apparatus, fall most directly into relation with Hertwig's idea in that they possess a permanent though varying supply of extra-nuclear functioning material which is re-supplied as occasion may demand, and which serves to bring the nuclear substance into

<sup>2</sup> HERTWIG: *Archiv für Protistenkunde*, 1902, i, p. 1.

<sup>3</sup> GOLDSCHMIDT: *Archiv für Protistenkunde*, 1904, v, p. 126; *Zoologisches Jahrbuch Anatomische Abtheilung*, 1904, xxi, p. 41.

<sup>4</sup> SCOTT: *University of Toronto studies*, No. 1, 1900.



more intimate relation with the cytoplasm of the cell necessary for its active function.

Therefore, not only from more theoretical considerations, but in the light of the definite facts of its behavior in the later stages of the process, it is obvious that the reaction on the part of the chromatic material in the earlier stages was rendered easy of interpretation.

More fundamental even than the theories outlined is Hertwig's doctrine of the nucleus-plasma relation. According to Hertwig,<sup>5</sup> "for each cell there exists a definite size relation of nuclear mass to cell mass which may be represented by the formula  $N/P$ ."<sup>6</sup> Further, he is convinced not only that the relation is intimately connected with the life processes of cells, but also that it may experience more lasting changes under the influence of uninterrupted function, starvation and changes of temperature. Its application to the points at issue has been indispensable in separating the stages of the process, and its further extension promises to be productive of wider information concerning the activities of nerve cells.

In the discussion of the stages in detail, it is to be remembered that the process is a continuous one, with each stage described merging into the following one by rapidly changing gradations. Consequently, the division into stages is in some measure an arbitrary one and is used for the convenience of description. On the other hand, it will be apparent that the changes from the middle point of one to the middle point of the next are so decided that such a classification is warranted. Unless borax-carminé is specifically stated, the description is based upon the methylene blue stain. For the most part the appearances are exactly comparable.

Some prior explanation of the source of the calculations of the volume and the nucleus-plasma relation to which reference is made is necessary. The facts stated are based upon statistics from nearly 1500 cells, which does not include those previously published. This number is made up of five series drawn from four experiments, two series being after alcohol fixation, two after picrosulphuric, and one being a repetition after corrosive formalin. In one series 50 and in the others 25 cells belonging to each stage were measured. With the exception of one series, the data are

<sup>5</sup> HERTWIG: Gesellschaft für Morphologie und Physiologie Sitzungbericht, 1903, xviii, p. 77; Biologische Centralblatt, 1903, xxiii, pp. 49, 208.

<sup>6</sup> HOWARD: The Johns Hopkins Hospital bulletin, 1908, xix, p. 161.

derived from material from shock experiments and will appear shortly elsewhere under that head. Unfortunately, it is not applicable throughout to the present purpose, because in the material investigated normal cells and the very earliest stages were entirely lacking, which necessitated the taking of the one or the other of the early stages of hyperchromatic cells as the standard. However, one series of measurements has been made from the present work in Experiment 3, and is complete from the normal cell to the end, 25 cells being measured in each stage. The results coincide with satisfactory uniformity with those in shock, and it is felt that the statements about the extreme upset of the nucleus-plasma relation are trustworthy. But for comparison between the normal cell and its immediately succeeding stage, the data from 25 cells only in each group are insufficient. Exhaustive measurements will be necessary to determine the variations in size and in the nucleus-plasma relation in the normal functional states to which these cells correspond. For this reason and because the data on the complete upset of the nucleus-plasma relation with its necessary lengthy explanation of calculations will be more appropriately considered separately elsewhere, no figures will be given.

**The normal cell (Fig. 1).** — In agreement with the usual description, the shape of the Purkinje cell of the dog's cerebellum conforms generally to that of a pear, with the small end continuing as the dendrite. The most frequent modification is due to the occurrence of two dendrites, which makes the contour triangular, indicating a more pyramidal shape. The elliptical nucleus has its acid staining nucleolar substance, the plastin, arranged in a moderately loose reticulum. The usually so-called nucleolus, which is an amphinucleolus, or, in the modern significance of the word, karyosome, is composed of a basis of nucleolar substance upon which is superimposed a layer of the only basic chromatin present by the Held stain. This structure becomes very apparent in the final stages of disintegration of the karyosome. The extra-nuclear basic chromatic material, the so-called Nissl substance, varies not only in different individuals but in different cells of the same individual. It is also arranged in the form of a network which is massed at the nodal points. In addition, the elongation of the meshes in the direction of the long axis of the cell, particularly toward the dendrite pole, gives the appearance of distribution as rods or spindles. This description is based upon the routine sections of 5 micra thickness.

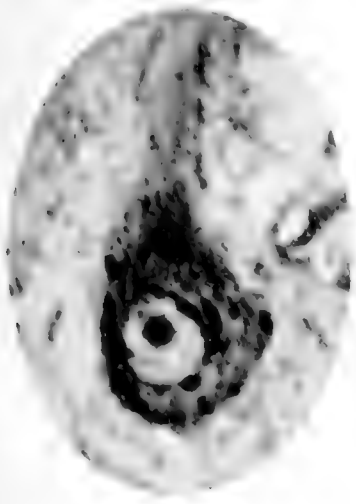

FIG. 1



FIG. 2

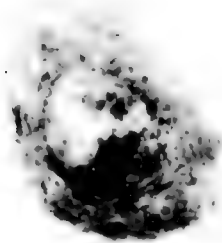

FIG. 3



FIG. 4

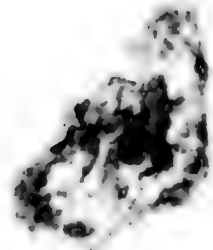
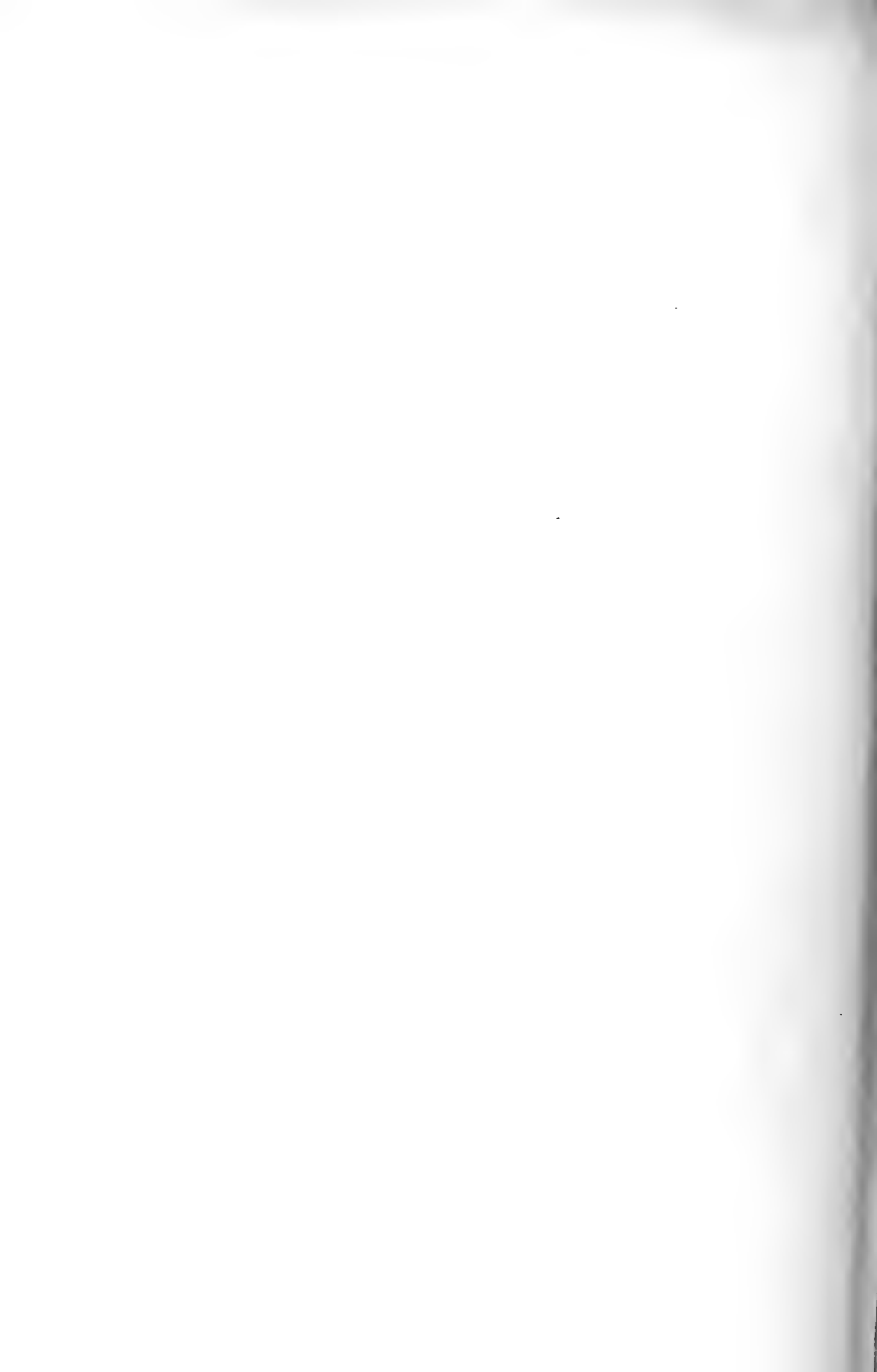

FIG. 5



Observations upon these as well as upon thinner sections tend to support the conclusion of Held<sup>7</sup> that in their finer structure the tigroid masses are finely granular. Stained by borax-carminé after mercury fixation, the only differences result from the elective qualities of the dye with its more intense affinity for the basic chromatic material.

**The initial stages of hyperchromatism (Figs. 2 and 3).**— Starting with the normal cell for any particular animal, the first indication of activity is the increase of the extra-nuclear basic chromatic material. This increase is manifest both in the size and in the number of the granules. Probably the increase in size antecedes. The next indication of the further progress of the increase is the appearance of diffused chromatic material within the cytoplasm. The diffuse stain obscuring the ground substance contrasts with the previously sharp differentiation from the basic element. Massing of the chromatic material about the nuclear membrane particularly, either irregularly or as a complete ring, becomes here an index of greater nuclear activity. Coincident with the above, the closer meshing of the nuclear reticulum becomes apparent. So far as the meagre measurements go, there is an initial increase in size for both nucleus and cell body. Lugaro found the same result in his exhaustive measurements upon ganglion cells.

**The stages of hyperchromatism: I (Fig. 4; Fig. 1, first communication;<sup>1</sup> Fig. 1, second communication<sup>2</sup>).**— Next there ensues an excess of the diffused basic chromatic material within the nucleus, which, as previously stated, shows none prior to this (Note, Fig. 3). From this point, where the cellular elements are still distinctly outlined, the basic chromatic material may increase to such a pitch of hyperchromatism that they are almost or entirely obscured. However, before this happens, the condensation of the nucleus, whose first indication was its closer meshing, becomes marked. With the Held stain it is solid and homogeneous. With borax-carminé the same condensation is noticeable, though the network is not entirely obscured. With the latter stain also, deep staining nodal points mark the presence of free basic chromatic material within the nucleus. The nucleus as a whole is more intensely stained by it than the cytoplasm. It is absolutely definite that homologous cells after the two

<sup>7</sup> HELD: *Archiv für Anatomie und Physiologie, Anatomische Abtheilung*, 1895, p. 396; *Ibid.*, 1897, p. 204.

different dyes are stained with equal intensity as compared with other types. Certain irregularities of contour of both cell and nucleus are frequently to be seen after all fixatives, but as they reach their maximum in succeeding stages the discussion will be reserved. From the measurements it is evident that not only are both nucleus and cell body distinctly smaller as compared with the preceding group with its initial increase, but also that the shrinkage of the nucleus is relatively greater than that of the cytoplasm. In other words, the nucleus-plasma relation is disturbed to the advantage of or in favor of the cytoplasm. The end of this stage marks the point of maximum production of basic chromatic material.

**II** (Figs. 6 and 7; Fig. 2, second communication'). — The conclusion previously stated for the shock and anemia material that this and the succeeding stage represent the final stage of the initial reaction has been strengthened by the fine differentiation here possible and the uniform results of the exhaustive measurements on the shock series. Passing on from the stage of intense hyperchromatism, the excess of chromatic material gradually disappears. The nucleus clears up, and then the amount in the cytoplasm becomes appreciably less, though these stages are still relatively hyperchromatic. More striking and characteristic are the changes in size and shape. The cells which are grouped in this class usually average even less than half the computed volume for the preceding stage. But again the nucleus is the more affected, so that the nucleus-plasma relation is even more in favor of the cytoplasm than in the preceding group. Their shape is bizarre, spindle-like, attenuated, and irregular, with an elongated and extremely irregular nucleus. So narrow are they at the dendrite pole that it is impossible usually to fix a standard in measuring for the point of union of the cell with the dendrite. Having thus sufficiently identified them as an independent group, discussion will be left until the next group is considered on account of their many points in common.

**III** (Fig. 5; Fig. 3, second communication'). — This is equally as irregular without the attenuation, for the original shape is more generally suggested. The contour of both cell body and nucleus is shrunken, uneven, due to large indentations which may give it actually a crenated appearance.

While larger than the preceding group, the size is still considerably smaller than the first stages of hyperchromatism. Accurate estimation of their volume is difficult on account of their extreme

irregularity, and it is probably even less than the calculations indicate, for as a standard rule the longest diameters were measured.

The basic chromatic material in this as well as in the preceding stage, though still absolutely increased in amount, shows indications of distinct clearing up and diminution, usually in separate areas, while an irregular massing here and there remains a distinct feature. In the later stages the disappearance is especially marked toward the dendrite pole. On the basis of the character of the nucleus more particularly than the state of the chromatic material it is possible to subdivide this stage. The earlier group possesses the same condensed nucleus as the two preceding stages. In the later subdivision the nucleus is considerably larger, and has lost in part its shrunken appearance. The reason for this is the edematous condition which later becomes so marked. The appearance after both stains is of small breaks or rifts in the condensed nucleolar substance, usually just under the nuclear membrane or at one pole. It is to be noted that the same may occur in the cells of stage two. Always in a nucleus of this distinct type, a certain amount of the condensed matrix remains intact and is recognizable. And afterward, when the edema comes to loosen it all, the meshwork is in part disrupted and has not the appearance of that in the normal cell, a point which helps in the diagnosis of the next stage.

The nucleus-plasma relation varies in this type according to whether it is considered as a whole, or the calculations are made upon its two subdivisions. If the former, the quotient  $N/P$  is less than that of the preceding stage. It depends upon the relatively greater size of the nucleus in the end stage. The relation in the early stage, calculated separately, may be even somewhat more in favor of the cytoplasm than in the preceding stage two. But in the later stage there is a decided tendency to that shift in favor of the nucleus which reaches its maximum in the stage immediately following. When they are calculated together, the later stage more than counterbalances the earlier and lowers the ratio.

In considering the character of these morphological alterations the greatest dependence is placed upon preparations after sublimate fixation. While usually not absolutely so marked, the distortion as compared with cells of all the other stages is just as striking and characteristic. There can be no doubt that these cells represent actual morphological states and are not artefacts of stain, fixation, or handling. This is the type of cell which Hodge delineated and

dealt with particularly after osmic acid fixation. In fact, whatever the technic, they have been invariably found and described by others under suitable functional conditions.

The relative position of stages two and three to each other in the process presents difficulty. This is not the case in the matter of their relation as a correlated group to the whole process. Grading down from the hyperchromatic cells, in which, as was stated, the characteristic changes may appear to some extent, intermediate stages of transition into both forms are readily seen, and in diagnosis for measurement they frequently have to be passed over as capable of being classified with either group. The relation of the two types to the succeeding stages is evident from their showing at the end the first indication of that marked upset in the nucleus-plasma relation in favor of the nucleus which reaches its maximum in the next stage. In the difficulty just mentioned there are several facts which seem to point toward a solution. First, both stages may show this upset. Second, reference to the table of differential counts shows that cells of type two are much less abundantly found than cells of type three. Third, it appears from intermediate stages of direct transition of cells of type one to type three that the cells of type three do not have to pass through type two. From these facts the deduction is made that they are likely coincident in place, and the most reasonable supposition appears to be that the explanation of their occurrence lies in the variations in the normal shape of cells. Observations go to show that it is at the summit of the convolution in the cerebellum that modified shapes of cells are most likely to occur in the way of slenderness, and it is at the same place that cells of type two are found more frequently than elsewhere. This explanation, however, is made tentatively.

**The first stage of the upset of the nucleus-plasma relation in favor of the nucleus (Fig. 8).**— The differentiation of this stage is of extreme importance. The consumption of basic chromatic material having proceeded at a greater rate than its production, the cell has now arrived at a point where there is very close to an average amount in the cytoplasm with a nearly normal distribution. It is passing through a semblance of normal, and without critical examination it looks like a normal cell. The measurements show that the cell body is little larger than type three, and it may be the same size, though without its irregularity, for the edema begins now to affect the cytoplasm. Its distinguishing point is its nucleus, which is large



out of all proportion to the size of the cell, though it is yet smaller than normal. For the same reason as the cytoplasm, the nucleus becomes rounded out by edema. In fact, the uniform result of the measurements is that at this stage the maximum disproportion between nucleus and cytoplasm is practically reached to the extreme advantage of the nucleus. It is true that the distribution of chromatic material is not quite normal, particularly toward the dendrite pole, and that the nuclear reticulum is somewhat disintegrated, but neither of these points is striking. There can be no doubt that in conditions of any severity, in which experience has shown that cells may be lacking even so far along as the hyperchromatic stages of type one, the cells of this group have been regarded as normal. It was only by the consideration of the nucleus-plasma relation that the clue to their existence was given.

This brings the process up to the point where detailed description began in previous communications of the further diminution of chromatic material with complete set of illustrations in the first one.<sup>2</sup> It will be sufficient, therefore, merely to summarize the essential stages. First, the extra-nuclear chromatic material very nearly or completely disappears from the cytoplasm. Second, this is followed by a final and extraordinary spurt of activity on the part of the nucleus characterized by the piling up of chromatic material about the nuclear membrane and its diffusion into the cytoplasm. Fig. 9 of this series is a transition between these two stages. Throughout the final stages the size of both nucleus and cell body steadily increases; but at this point the volume of the cell body becomes relatively more augmented, so that the nucleus-plasma relation which has remained in favor of the nucleus begins to shift the other way again in favor of the cytoplasm, showing that the nucleus is rapidly becoming exhausted. When the supply of chromatic material just mentioned has passed out and been entirely used up, the karyosome remains as the only vestige of such basic material. Fig. 10 represents a cell which has almost reached this point. Finally, the karyosome yields up its quota, which after diffusion into the cytoplasm also disappears completely, leaving a cell entirely devoid of basic chromatic material, in short, a dead cell.

No interpretation beyond a general one of the significance of the individual stages will be attempted. Activity, fatigue, and exhaustion are relative terms, and represent states which merge impercep-

## DESCRIPTION OF PLATES.

The photomicrographs, which were made from a routine Held stain, are all from Experiment 3, and, with a single exception (Fig. 10), were taken from a single preparation of three sections. This single set, reproduced at a constant magnification, agrees almost exactly in its size variations with the statements made from averages. (Leitz oc. 4, obj. 1/12 oil immersion,  $\times 1150$ .)

FIGURE 1. — The resting cell.

FIGURES 2 and 3. — Early and progressive stages of hyperchromatism.

FIGURE 4. — Marked hyperchromatism with some irregularity of contour.

FIGURE 5. — Shrunken, crenated cell, with condensed nucleus, illustrating the early stage of text division Hyperchromatism 3.

FIGURES 6 and 7. — Two types of the attenuated spindle cells thought to be coincident in place with Figure 5 (Text division, Hyperchromatism 2). Figure 7 shows the edematous break at one pole, illustrating the later division of both this and the preceding stage.

FIGURE 8. — Though with an average amount and a practically normal distribution of basic chromatic material, the edema and the enormous size of the nucleus relative to the cytoplasm are apparent.

FIGURE 9. — An intermediate stage of the first almost complete using up of the extranuclear basic chromatic material with the beginning of a renewed supply shown by its perinuclear massing.

FIGURE 10. — A cell in which the basic chromatic material has been almost entirely used up with the exception of an intact karyosome.

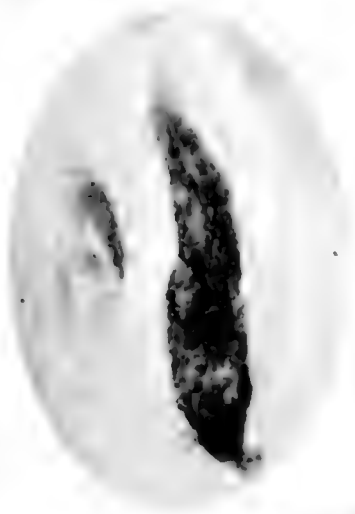

FIG. 6

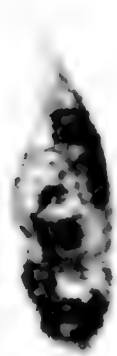

FIG. 7

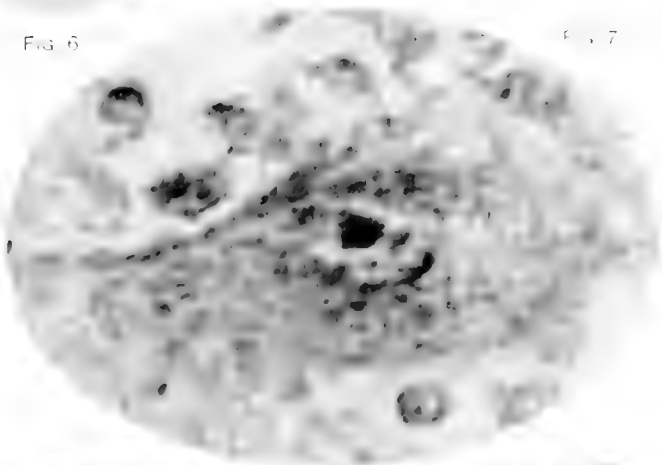

FIG. 10

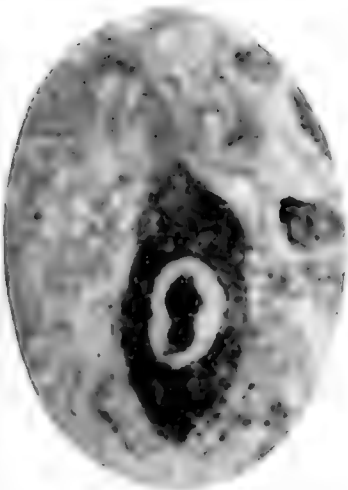

FIG. 8

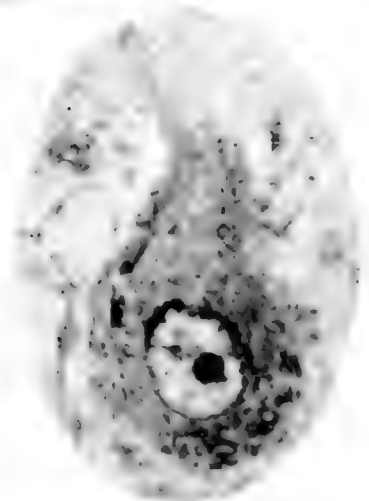
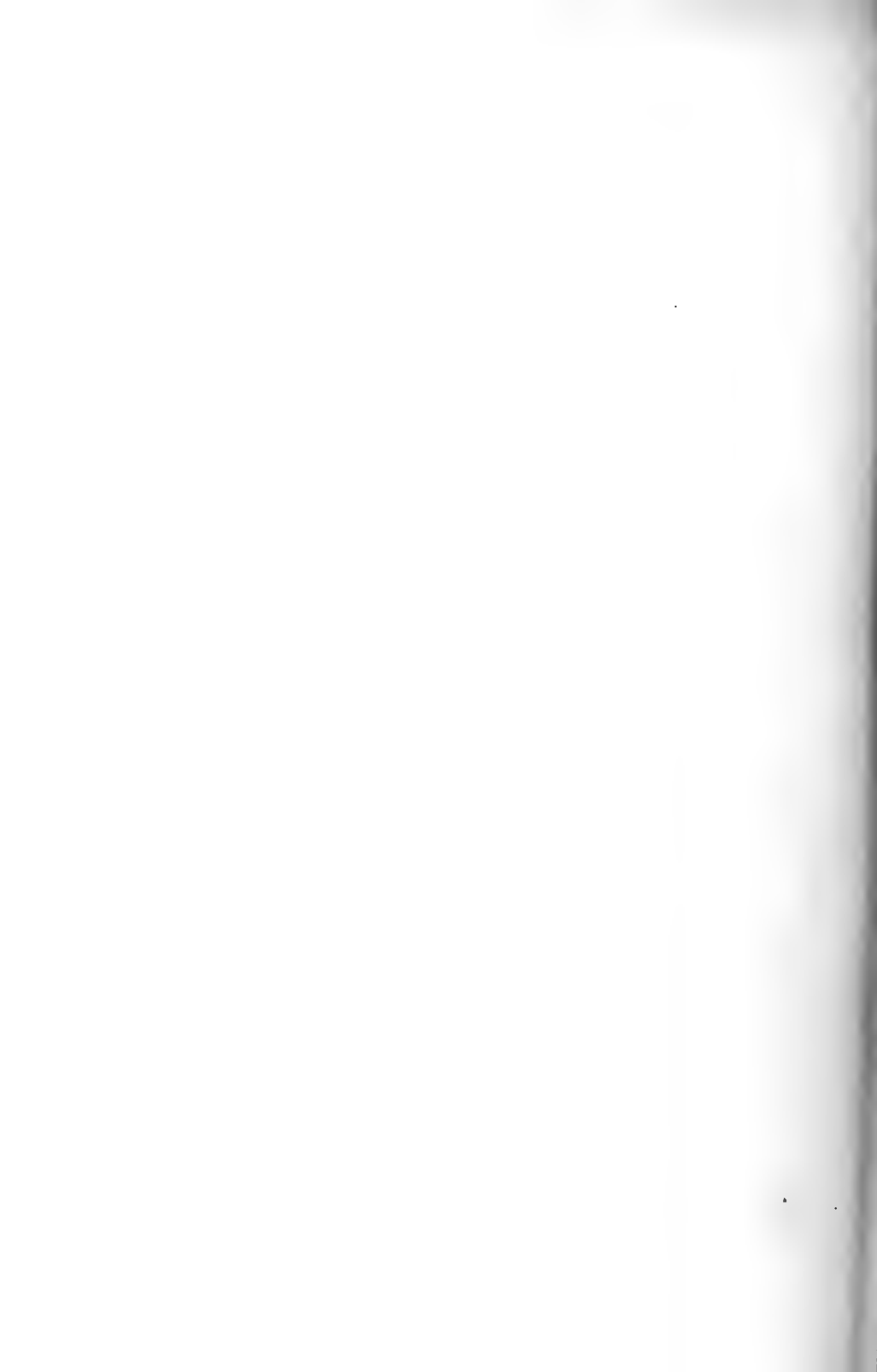

FIG. 9



tibly one into another. It is impossible as yet to translate each individual morphological appearance into its abstract conception, if it will not necessarily be always so within certain limits. It is hoped that the studies contemplated on the power of recuperation and the measurement of cells in normal functional states will throw additional light on the problem so far as it admits of solution. This much is clear, — that the initial stages represent activity and the end stages absolute exhaustion, while somewhere between are the stages of fatigue. The occurrence of hyperchromatic cells of type one in large numbers in animals presumably in a normal unfatigued condition may plausibly be taken to indicate that such cells are the expression of normal activities. However, the superadded structural alterations which here first make their appearance lead one to think that they are close to the border line of fatigue. Still this step may be relatively long. There can be no doubt that the distorted cells represent fatigue, and that the beginning of the profound upset in the nucleus plasma relation from a state favoring the cytoplasm to one favoring even more decidedly the nucleus, represents greater fatigue. What are the limits of what may be called a physiological fatigue? How far can the cell go and yet recover itself? May certain cells represent imperfect states of recovery in the way of permanent disorganization from previous strains? These and other allied questions remain for an attempt at solution.

#### THE RESULTS OF DIFFERENTIAL COUNTS.

Various considerations led to the attempt to obtain, so far as possible, an exact numerical expression of the distribution in the various animals of the stages described. For the present purpose the main object was to find out to what extent there was correlation with the experimental variations. In the second place, it is not only an initial step in establishing a base line for determining the power of recuperation, but also an index is afforded for planning these experiments. The necessity is obvious that they be widely controlled. Finally, the hope was entertained that some indication of localization in the cerebellar cortex might be derived from the comparison of the different areas.

While the results are, as a whole, satisfactory, and even exceed expectations, it is well recognized that they are open to objection

TABLE I.

No. of exp.	Tissue from the	Un-counted cells.	Same, divided as to chromatic material into		Resting cell. Stage 1.	Stage 2.	Stage 3.
			Dis-tinct.	Faint.			
Experiment 5 control	Worm . . . . .	...	...	...	70	49	61
	Uvula . . . . .	132	127	5	64	44	87
	Biventral lobe . . . . .	<u>122</u>	<u>122</u>	0	77	68	47
	Total . . . . .	...	...	...	<u>211</u>	<u>161</u>	<u>195</u>
Experiment 6 $\frac{1}{4}$ hour	Worm . . . . .	148	139	9	40	60	84
	Uvula . . . . .	208	206	2	16	45	99
	Biventral lobe . . . . .	<u>148</u>	<u>116</u>	32	42	35	66
	Total . . . . .	...	...	...	<u>98</u>	<u>140</u>	<u>249</u>
Experiment 4 $\frac{1}{2}$ hour	Worm . . . . .	...	...	...	8	42	63
	Uvula . . . . .	123	...	...	7	31	80
	Biventral lobe . . . . .	<u>220</u>	<u>173</u>	47	27	54	59
	Total . . . . .	...	...	...	<u>42</u>	<u>127</u>	<u>202</u>
Experiment 3 1 hour	Worm . . . . .	...	...	...	8	56	28
	Uvula . . . . .	201	...	...	12	37	24
	Biventral lobe . . . . .	<u>213</u>	<u>167</u>	46	14	68	43
	Total . . . . .	...	...	...	<u>34</u>	<u>161</u>	<u>95</u>
Experiment 2	Worm . . . . .	...	...	...	0	0	13
	Uvula . . . . .	253	127	126	0	5	10
	Biventral lobe . . . . .	<u>227</u>	<u>62</u>	165	0	0	18
	Total . . . . .	...	...	...	<u>0</u>	<u>5</u>	<u>41</u>
Experiment 7	Worm . . . . .	165	66	99	0	3	11
	Uvula . . . . .	230	153	77	2	9	71
	Biventral lobe . . . . .	<u>290</u>	<u>183</u>	107	1	4	25
	Total . . . . .	...	...	...	<u>3</u>	<u>16</u>	<u>107</u>

EXPLANATION OF TABLE I. — Results of the differential counts of 200 cells each from 3 areas, with division into 13 stages from the resting cell through the consecutive stages of activity to complete exhaustion, and a record so far as made of the cells not sufficiently in plane of section to diagnose in covering the ground. The figures marked prime refer to the first paper<sup>1</sup> on shock, the others to the photographs here presented.

Stage 1 (Fig. 1). — Resting cell for the particular animal. Stage 2 (Figs. 2 and 3). — Early phases of hyperchromatism. Stage 3 (Fig. 4). — Markedly hyperchromatic cells. Stage 4 (Figs. 6 and 7). — The distorted, attenuated cell. Stage 5 (Fig. 5). — The shrunken but more pear-shaped cell. Stage 6 (Fig. 8). — The semblance of the

TABLE I.

Stage 4.	Stage 5.	Stage 6.	Stage 7.	Stage 8.	Stage 9.	Stage 10.	Stage 11.	Stage 12.	Stage 13.
8	5	5	1	1	0	0	0	0	0
5	0	0	0	0	0	0	0	0	0
1	2	5	0	0	0	0	0	0	0
<u>14</u>	<u>7</u>	<u>10</u>	<u>1</u>	<u>1</u>	<u>0</u>	<u>0</u>	<u>0</u>	<u>0</u>	<u>0</u>
1	5	2	5	1	0	0	0	2	0
16	17	2	4	1	0	0	0	0	0
3	23	3	16	5	0	2	0	2	3
<u>20</u>	<u>45</u>	<u>7</u>	<u>25</u>	<u>7</u>	<u>0</u>	<u>2</u>	<u>0</u>	<u>4</u>	<u>3</u>
22	28	5	12	9	0	2	0	1	8
4	17	11	22	13	0	1	3	0	11
13	34	9	1	0	0	1	0	0	2
<u>39</u>	<u>79</u>	<u>25</u>	<u>35</u>	<u>22</u>	<u>0</u>	<u>4</u>	<u>3</u>	<u>1</u>	<u>21</u>
18	19	15	26	23	0	6	0	0	1
18	36	23	20	13	1	4	2	8	2
12	38	2	6	3	0	4	0	5	5
<u>48</u>	<u>93</u>	<u>40</u>	<u>52</u>	<u>39</u>	<u>1</u>	<u>14</u>	<u>2</u>	<u>13</u>	<u>8</u>
24	26	42	16	12	2	19	9	4	33
9	34	12	32	13	1	21	4	16	43
10	76	13	11	10	3	10	5	14	30
<u>43</u>	<u>136</u>	<u>67</u>	<u>59</u>	<u>35</u>	<u>6</u>	<u>50</u>	<u>18</u>	<u>34</u>	<u>106</u>
32	48	9	20	14	9	11	3	13	27
15	47	7	21	8	0	3	0	1	16
11	95	9	28	2	5	5	1	0	14
<u>58</u>	<u>190</u>	<u>25</u>	<u>69</u>	<u>24</u>	<u>14</u>	<u>19</u>	<u>4</u>	<u>14</u>	<u>57</u>

normal cell with marked upset of the nucleus-plasma relation in favor of the nucleus. Stages 7 and 8. — Early and late stages of the first complete using up of the extra-nuclear basic chromatic material (Fig. 3' for late stage). Stage 9 (Fig. 9, Fig. 4'). — The piling up of chromatic material about the nuclear membrane which characterizes the final effort in the elaboration of basic chromatic material. Stage 10 (Fig. 5'). — Intermediate stages of the using up of the last mentioned secondary supply. Stage 11 (Fig. 10, Fig. 6'). — The basic chromatic material with the exception of the karyosome is entirely used up. Stage 12 (Figs. 7', 8', 9'). — The giving up of its basic chromatic material by the karyosome. Stage 13 (Fig. 10'). — No basic chromatic material is left, and the cell is absolutely exhausted.

and must be viewed with caution. In making a classification of each consecutive cell so far as possible from a given starting-point, which was the absolute rule, the difficulty lies in the number that are unrecognizable because they are not sufficiently in the plane of section. This number varies considerably, as can be seen by a reference to the table. With the idea of controlling this, the plan was first adopted of keeping a record of the uncounted cells in making a given enumeration. This in turn was followed by the subdivision of these cells into two groups; the one with a distinct staining reaction, the other with a faint coloring. Undoubtedly this gives some check on the results, for the difference between an early and a late stage, for example, between Experiments 6 and 2 (Table I), is very striking. However, the number of cells uncounted varies from 123 to 290 in getting exact figures for 200. That is to say, in one case the 200 were out of 323 cells, in the other out of 490. These are extremes, and usually the total figure is not far from 400. Finally, given a section cut in the most proper direction, the great size differences between initial and final stages will always result in a greater proportion of uncounted cells in severe cases.

Two hundred cells were counted in six cases from the worm, the uvula, and the biventral lobe. Counting 100 usually covered the most of one section, and two, well separated, were always used. The Held stain of alcohol preparation was used for all.

No extensive discussion seems necessary for present purposes, for the appended tables giving the complete figures supply the data in concise form. In the puppies there is a striking increase in the intensity of the reaction *pari passu* with the increased exertion, which is well graded, as reference to the table of totals will show. It is to be noted in the control that while there are 12 cells under the head of extreme upset of the nucleus-plasma relation, 10 of these come under the first stage of that group, while the others immediately follow. In explanation of the practically identical numbers in the two final stages of Experiments 3 and 4, it is to be remembered that the one-hour dog was the strongest and most playful of the litter. The reaction, as a whole, appears relatively more intense in the puppies when the prolonged exertion of the other dogs is considered. However, their age would render them incapable of the sustained effort of the older dogs, and their previous existence had been spent within the confines of a small yard.

On comparing the two remaining groups, it is evident that Experi-



TABLE II.

No. of exp.	Tissue from the	Resting cell to marked hyperchromatism. Stages 1-3.	Shrunken and distorted cells. Stages 4-5.	Upset of the nucleus-plasma relation. Stages 6-end.
Experiment 5	Worm . . . . .	180	13	7
	Uvula . . . . .	195	5	0
	Biventral lobe . .	192	3	5
	Total . . . . .	567	21	12
Experiment 6	Worm . . . . .	184	6	10
	Uvula . . . . .	160	33	7
	Biventral lobe . .	143	26	31
	Total . . . . .	487	65	48
Experiment 4	Worm . . . . .	113	50	37
	Uvula . . . . .	118	21	61
	Biventral lobe . .	140	47	13
	Total . . . . .	371	118	111
Experiment 3	Worm . . . . .	92	37	71
	Uvula . . . . .	73	54	73
	Biventral lobe . .	125	50	25
	Total . . . . .	290	141	169
Experiment 2	Worm . . . . .	13	50	137
	Uvula . . . . .	15	43	142
	Biventral lobe . .	18	86	96
	Total . . . . .	46	179	375
Experiment 7.	Worm . . . . .	14	80	106
	Uvula . . . . .	82	62	56
	Biventral lobe . .	30	106	64
	Total . . . . .	126	248	226

EXPLANATION OF TABLE II. — The totals derived from the closer grouping of the stages of Table I.

ment 7 reacted morphologically less than Experiment 2, though the former experienced the more sustained if not so severe effort. This is somewhat counterbalanced by the greater number of distorted fatigued cells. Neither dog had been confined long, and nothing is known of their previous manner of life nor extent of training.

With regard to any indication of localization, the results are inconclusive. This would naturally be expected in experiments of the character studied. Reference to such a means of determination is made because the procedure may ultimately prove of value, possibly in the cerebellum itself, more probably in identifying localizations elsewhere, which are better defined. In three of the five experiments to be considered, reference to the last column of the table of totals shows that the order in ascending scale of the intensity of reaction is biventral lobe, worm, and uvula. In the other two the order is changed, so that there are all the possible combinations; nor does the consideration of the other figures help the matter. The generally greater reaction in the median portion agrees with the opinion that it is of especial importance in equilibration (Lewandowsky).<sup>8</sup> Further material and more exhaustive counts may add weight.

#### SUMMARY.

Physiological activity in nerve cells, as studied so far in the cerebella of dogs exercised in a treadmill, results in a definite and consecutive sequence of events which are the morphological expressions of the abstract terms activity, fatigue, and exhaustion. The interpretation of the various types of cells and their division into stages is based primarily upon Richard Hertwig's doctrines of the size relations of nucleus and cell body and of their interdependence as regards a mutual interchange of material, and upon the extension of Richard Goldschmidt's doctrine of chromidial apparatus (in the shape of the Nissl substance) to nerve cells.

As a result of continued activity, there is first a steady increase of the basic chromatic material, first the extra-nuclear (the Nissl substance), then the intra-nuclear, which is attended by an increase in size of the cell. Finally, an intensely hyperchromatic cell marks the maximum of elaboration of basic chromatin. From this point it begins to disappear, first from the nucleus as it continues to pass

<sup>8</sup> LEWANDOWSKY: Die Functionen des zentralen Nervensystem, p. 192.

out into the cytoplasm, then from the cytoplasm, resulting as the next stage in a cell still relatively though more irregularly hyperchromatic. Accompanying the disappearance of chromatic material is a marked shrinkage in size, relatively greater for the nucleus than for the cell, with extreme irregularity and actual crenation of contour of both. The result is that the nucleus-plasma relation becomes more in favor of the cytoplasm. There are two main types of such cells, the one attenuated, spindle-like, the other more of the usual pear shape of the Purkinje cell. Toward the end of both these stages a sharp increase in the size of the nucleus, due to edema, occurs, which helps to fix their relation to the succeeding stage. The advance of the nuclear edema, its later onset in the cytoplasm, and the still continuing using up of the extra-nuclear chromatic material result in a cell having the semblance of normal with an average amount and almost normal distribution of basic chromatic material, now well rounded out, but exhibiting nearly the maximum disproportion between nucleus and cell body and that in the opposite direction, *i. e.*, in favor of the nucleus. The using up of the chromatic material proceeds until it almost or entirely vanishes from the cytoplasm, whereupon there is an extraordinary discharge from the nucleus, which first masses about the nuclear membrane and gradually diffuses into the cytoplasm. Though the absolute size of both cell body and nucleus steadily increases through these stages to the end, at this point the relation between them changes, and from being in favor of the nucleus it shifts again to the advantage of the cytoplasm, which indicates the onset of nuclear exhaustion. With the using up of the secondary supply thus afforded the karyosome alone remains of basic chromatic material. Finally, the karyosome yields up its ultimate supply, and after its diffusion into the cytoplasm and consumption there results a functionally exhausted cell entirely devoid of basic chromatin.

The sequence of events is exactly identical with that previously described for anemia and shock, and the reaction to purely physiological states corroborates the opinion advanced that the changes in these conditions are a manifestation of functional activity and represent phases of fatigue and exhaustion.



CONTRIBUTION TO THE PHYSIOLOGY OF LYMPH.—  
IX. NOTES ON THE LEUCOCYTES IN THE NECK  
LYMPH, THORACIC LYMPH, AND BLOOD OF NOR-  
MAL DOGS.

BY BENJAMIN F. DAVIS AND A. J. CARLSON.

[From the Hull Physiological Laboratory of the University of Chicago.]

THE purpose of this work was: (1) to make comparative counts of the number and kinds of leucocytes in the blood, neck lymph, and thoracic lymph of normal dogs, and (2) to study the changes in the number and kinds of leucocytes in the blood of dogs following ligation of the thoracic duct and neck lymphatics. It was hoped that by these methods facts might be learned which would aid in explaining the differences in the concentration of the various enzymes and anti-bodies in these fluids, and throw light on the relation of the different kinds of leucocytes to such enzymes and antibodies. It was further thought that facts might be brought forth which would aid in determining the fate of the lymphocytes, and the means by which the co-ordination in the leucocytic content of blood, neck lymph, and thoracic lymph is maintained.

Sufficient work has been done on the cellular content of the thoracic lymph of animals to give us a fair idea of the cell types which are to be found there. Weidenreich<sup>1</sup> seems to express the general consensus of opinion when he says that "one finds in the thoracic duct of the rabbit, dog, cat, guinea-pig, and monkey, non-granular cells in large numbers, especially small lymphocytes, but next to these large leucocytes with round nuclei, in which last all stages of mitosis are met. . . . Finely granular leucocytes (neutrophile and amphophile) are few, as are eosinophile leucocytes." In addition to this statement of Weidenreich we may safely say that the finely granular neutrophiles or amphophiles occur only as evidence of blood contamination and that mast cells are absent.<sup>2</sup> Rous maintains that the number of eosinophiles is not inconsiderable, since they averaged 2.6 per cent of all leucocytes in the thoracic lymph of his series of dogs.

Red blood cells are frequently found in lymph. On the strength of this finding and a few dissections and experiments reported by Leaf,<sup>3</sup> Boeddaert,<sup>3</sup> and Lippi, it has been assumed that red blood cells are a normal constituent of thoracic lymph, due to a direct admixture of blood and lymph by way of anastomosis between lymphatics, arteries, and veins. While admitting the frequent presence of red blood cells in thoracic and neck lymph procured in the ordinary way, the opinion expressed in this laboratory by men who have obtained lymph from some hundreds of dogs, rabbits, and cats, is that it is easily feasible by careful dissection and gentle handling of the animals before and during anæsthetization to obtain lymph free from erythrocytes. Hence the conclusion that red blood cells are normal constituents of thoracic lymph does not seem to be well founded. Such red cells as find their way into the lymph stream probably do so following injury to the vessel walls produced during the strain and struggle of the period of excitement in etherization, or during the actual work of dissection.

The number of leucocytes in thoracic lymph is variously given at from 2000 to 20,000 per c.mm. Thus Winternitz<sup>4</sup> found from 2000 to 7000 leucocytes in dog's thoracic lymph, while Haedicke,<sup>5</sup> from a study of the fresh chyle from a case of ruptured thoracic duct in man, reports the number of cells — "small round cells, or cells with notched nuclei" — as varying between 2000 and 20,000. Rous,<sup>7</sup> working with special precautions, found 990 leucocytes per c.mm. in the thoracic lymph of one dog, and 11,161 per c.mm. in another, of a series of 14 dogs, the average number of leucocytes for the series being 5000 per c.mm. Other observers also report wide variations which they seek to explain on Ehrlich's<sup>6</sup> idea of the effect of the variations of the rate of lymph flow: viz., an increased lymph flow flushes out the lymphatic vessels and glands while a diminished current permits the cells to settle out in various parts of the lymphatic system. The fact which we have noticed, that after prolonged massage the number of cells tends to decrease, apparently lends some support to this "flushing out" idea.

The cells of the lymph from the limbs have not been extensively investigated. Winternitz<sup>4</sup> "took lymph from the dog's thigh, following the injection of turpentine into the corresponding foot, and came to the conclusion that with inflammation of a part the cell content of the lymph coming from it is increased, and the majority of the cells becomes one of polymorphonuclear neutrophiles."

As regards the cellular content of the neck lymph, there are, so far as we know, no definite reports in the literature, though Hayem<sup>9</sup> found in the lymph taken from a lymphatic vessel running by the side of the carotid artery in the horse chiefly "opaque mononuclears." Elements corresponding to the eosinophiles of the blood were found. He remarks: "It is interesting to note that one may find them in the lymph."

The mode of entrance of the lymphocytes of the blood into the blood is of considerable interest, and the opinion seems to be growing — contrary to the idea that the lymphocytes pass directly from the spleen, bone marrow, and lymph glands into the blood — that these cells produced in the spleen, lymph glands, and bone marrow, enter the lymphatic vessels and reach the blood stream via the thoracic duct and the lymphatics of the right shoulder and of the right side of the head and neck. The evidence for this idea is of two kinds: First, we have the absolute lymphocytosis produced by the injection of lymphagogues of the first and second order,<sup>7</sup> and by the injection of pilocarpine.<sup>29</sup> These procedures not only cause an increased flow of lymph, but they also cause an increase in the number of cells in the lymph. The increased lymph flow, according to Ehrlich, flushes out the lymphatic glands and vessels, so that more lymphocytes reach the blood, — hence the absolute lymphocytosis. Secondly, by tying off the thoracic duct and neck lymphatics, or by removing important groups of lymph glands, a great reduction in the number of lymphocytes in the blood can be made to occur. Thus, Selinoff,<sup>10</sup> Biedl and v. Decastello,<sup>11</sup> Crescenzi,<sup>12</sup> and others report decreases in the number of lymphocytes in the blood following ligation of the lymphatics, or the making of a fistula, or from 79 per cent to 95 per cent, while Ehrlich and Reinbach<sup>13</sup> found 0.6 lymphocytes in every 100 leucocytes, instead of 25 in every 100 leucocytes in the blood after the extirpation of several groups of important glands.

The relative concentration of leucocytes in lymph and blood is apparently by no means a constant. Thus, Ranvier<sup>14</sup> reports "that the number of cells in the thoracic lymph of a dog was 4800 per c.mm.; in another, 7500 with 25,000 in the blood, while in a cat there were 11,300 leucocytes per c.mm. in the thoracic lymph, and only 7500 in the aortic blood."

In spite of the extensive literature we are practically in the dark concerning the function or fate of the lymphocyte. On account of this lack of definite knowledge no discussion of the subject will be given here.

but the reader is referred to the works of Ehrlich, Miller,<sup>15</sup> Cleland,<sup>10</sup> and of Banti<sup>17</sup> for literature, experiments, and theories. Works on the pathology of blood diseases should also be consulted.<sup>18</sup>

Regarding the relative concentration of organic bodies, including under that heading enzymes and anti-bodies, it may be stated briefly that as a rule the concentration is greatest in the blood, next greatest in the thoracic lymph, and next in the neck lymph. The pericardial fluid and aqueous humor are poor in such bodies, while the cerebro-spinal fluid, in general, is free from them.<sup>19, 35</sup>

“The lymphagogues (strawberry extract, 10 per cent peptone, 10 per cent cane sugar, 5 per cent sodium chloride) have no effect on the relative concentration of the agglutinins in the serum and lymphs.”<sup>33</sup>

The lymphagogues do not alter the hemolytic power of the neck lymph. Peptone, hypertonic cane sugar, and sodium chloride may increase the hemolytic power of the lymph from the thoracic duct, and peptone may decrease the hemolytic power of the serum below that of the corresponding thoracic lymph.<sup>34</sup>

In the experiments reported in this paper, absolute and differential counts of the blood, neck lymph, and thoracic lymph of normal dogs were made, together with blood counts in three dogs in which the thoracic duct and neck lymphatics had been tied off. The absolute counts were made with a Thoma-Zeiss hemocytometer, the lymphs, as well as the blood, being diluted 1 to 10 with 0.3 per cent acetic<sup>20</sup> acid, in order to lake red corpuscles which might be present. As a rule three such counts were made of each specimen, care being taken to examine the full Thoma-Zeiss field of 256 small squares. The average of the three counts is reported in the tables. Sometimes the variations between the number of cells in the lymph specimens were wide, and sometimes the results were practically uniform, depending, as we found, upon the way the anæsthetic was administered; light anæsthesia with rapid breathing and occasional struggles producing a rise, and deep anæsthesia with the accompanying complete relaxation, a fall in the number of leucocytes. In one case the counts ran as follows: First count, thoracic lymph, 22,500 cells per c.mm.; second count, ten minutes later,—31,111 cells per c.mm.; third count, twenty minutes after the first, showed 27,500 cells per c.mm. In this case active massage of the abdomen ran the number of cells up to 65,000 per c.mm. In another case, with rapid but steady breathing, each of the three counts showed 34,375 leucocytes per c.mm. in the thoracic lymph.



For the differential counts smears were made in the ordinary way and stained with Wright's blood stain. All mononuclear, non-granular cells, large and small, were counted as mononuclear leucocytes, this group including, therefore, the small lymphocytes, the large lymphocytes or mononuclear leucocytes, and the endothelial-like cells, that is, large, non-granular cells with abundant cytoplasm and round, oval, or notched nuclei. Transitional forms, when they occurred in the lymph, which was rarely, were classed among the mononuclears. In the blood transitionals were but few in number, and here also were classed with the mononuclears. Eosinophile leucocytes, polymorphonuclear leucocytes, and degenerated forms were classed separately.

Our dogs were etherized in the ordinary way, six to eight hours after feeding, without the previous injection of morphine, so that in all cases the lymphs were obtained from animals which had just passed through a short period of struggle, with the consequent active massage of practically all of the lymphatics of the body. On this account the number of cells in these lymphs is probably somewhat larger than would have been the case had the dogs been kept quiet throughout. On the other hand, the exercise was probably but little more violent, and certainly not so long continued, as dogs frequently indulge in under normal conditions, so that, on the whole, our results may be said to represent fairly average conditions.

Two specimens each of neck and thoracic lymph were taken in every case. The first specimen — labelled "free flow" in the accompanying tables — was obtained before, and the second specimen — labelled "massage" — after, thorough massage of the parts.

## RESULTS.

As may be seen from the appended tables, the number of cells in the "free flow" thoracic and neck lymphs was, in most cases, about equal to, or somewhat exceeded the total number of leucocytes in the blood. Following massage, the number of cells in the lymph was immediately increased from two to five times, without, however, change in the relative number of the kinds of cells. After prolonged massage the cells of the lymph tend to decrease in number.

The cells of the neck lymph are practically 100 per cent small lymphocytes. In dogs No. IV and No. V, respectively, 0.1 per cent and 0.2 per

cent eosinophiles were found, thus agreeing with Hayem's findings in the horse.

In the thoracic lymph, from 95 per cent to 100 per cent of the cells are round cells, the vast majority being small lymphocytes, though an occasional endothelial-like cell, with all gradations in size between it and the small lymphocytes occurs. "Polymorphonuclear neutrophiles occur only as evidence of blood admixture." Eosinophiles are rare (0.1 per cent in one case). In this respect our results differ from those of Rous, who found an average of 2.6 per cent in the thoracic lymph of a series of dogs. Since the eosinophiles in the blood of most of our dogs were relatively few in number, and since it is known that the number of eosinophiles in the blood <sup>21</sup> and in the intestinal mucosa <sup>22</sup> as well, vary greatly with the quantity and character of the food, it seems possible that the differences between our results and those of Rous may be explainable on the basis of differences in the diet of the animals used.

As regards the leucocytes of the blood, our results agree in the main with those of other observers, excepting for the small number of eosinophiles seen in most cases.<sup>23</sup>

The records of three dogs in which the thoracic duct and neck lymphatics were ligated are given in the accompanying tables. A glance at the differential blood counts before and after operation indicates either a decrease in the number of lymphocytes following the operation, or a polymorphonuclear leucocytosis. Absolute counts show a leucocytosis. The operations were clean, and there was apparently no infection, though since the temperatures were not observed we cannot be sure on that point. Our experiments were too few and of too short duration to justify sweeping conclusions, but, judging from our findings, it seems reasonable to insist that before the results of differential counts can be accepted as proof of a decrease in the number of lymphocytes in such experiments as the foregoing, involving, as they do, quite extensive dissections, they should be checked by counts of the total number of leucocytes taken at the same time the smears are made. Our results in these experiments are not without parallel in the literature: thus, Winternitz <sup>4</sup> tied off the thoracic duct in 4 dogs and got a leucocytosis of from 6000 to 45,000 increase. He made no differential counts, and concluded simply that interruption of the lymph flow did not prevent leucocytosis.

DISCUSSION OF RESULTS.

I. Why are polymorphonuclear leucocytes not found normally in lymph from the large lymphatic trunks? The most plausible answer to this question seems to be that the polymorphonuclear cells, formed in the bone marrow, pass directly into the blood stream and reach the lymphatics only after diapedesis through the capillary endothelium. Once in the lymph stream one or all of three probable courses remain open: (1) they may make their way back into the blood stream through the capillary endothelium by the process of so-called "reversed diapedesis"; or (2) they may be phagocyted by the endothelium of the regional lymph glands, especially if they have been injured in any way; or (3) they may escape the lymph glands, either by being present in such numbers that the lymph glands cannot attend to them all, or by being carried around the lymph glands by way of anastomosing lymph vessels.

The first of these three possibilities may be of importance, but is difficult of demonstration; that the second may occur is very readily seen, especially if one examines microscopically the lymph glands draining an infected area; the third rarely, one can almost say "never," occurs normally, but has recently been demonstrated under experimentally produced pathological conditions by Carlson and Green.<sup>24</sup> These authors injected staphylococci into the parotid gland of dogs and examined the neck lymph after the lapse of a few days. They found large numbers of polymorphonuclears. Normally, then, it seems that such polymorphonuclear leucocytes as reach the lymph stream either "put on the reverse," so to speak, and make their way back through the capillary walls, or are phagocyted by the endothelial cells of the lymph glands, and hence do not find their way into the larger lymphatic trunks. The possibility of their being transformed into fixed tissue cells and in this way removed from the lymph stream may be mentioned.

II. As we have seen, there may be a much greater or a much smaller number of leucocytes in the lymph of the neck and thoracic lymphatic trunks than there is in the blood. The effects of massage and of changes in the rate of lymph flow produced by other means indicate that, irrespective of the number of leucocytes which may be present in any specimen of lymph from these sources, there is always a vast multitude of such cells — many more than there are in the blood — present in the lymphatic system and hence bathed with this same lymph, though not

carried in it. This is a fact which is worthy of emphasis in connection with the considerations to be mentioned shortly.

In the lymph practically 100 per cent of the cells are small lymphocytes, with a few of the larger mononuclear variety, both lymph (neck and thoracic) being about the same, while in the blood but 25 per cent of the leucocytes are mononuclears and 75 per cent are polymorphonuclears. Eosinophile and transitional cells are rare in blood and lymph. Mast cells do not occur in lymph and are rare in blood.

How can we correlate the above findings with the variations in the relative concentration of enzymes and antibodies in the normal body fluids? How can we correlate these facts with the effects of the injection of lymphagogues? It apparently cannot be done.

III. What becomes of the mononuclear cells which enter the blood with the lymph?

The blood of the dog forms about 7.7 per cent of the body weight of the animal.<sup>25</sup> Hence in a 10-kilo dog there would be about 0.77 kilograms of blood which would have a volume of about 729.85 c.c. The number of leucocytes in dog's blood is about 20,000 per c.mm., 5000 of which (25 per cent) are mononuclears. The blood of a 10-kilo dog would therefore contain about 3,649,250,000 mononuclear leucocytes.

According to Heidenhain<sup>26</sup> the lymph flow from the thoracic duct of dogs is equal to about 64 c.c. per kilo per day. In a 10-kilo dog, therefore, the daily lymph flow would amount to 640 c.c., or 640,000 c.mm. Supposing each c.mm. contained 20,000 mononuclear leucocytes. Then in the course of a day 12,800,000,000 mononuclears, or over three times the number actually to be found there at any one time, would be poured into the blood from the thoracic duct alone. The number of leucocytes entering with the neck lymph and from the hemolymph glands<sup>36</sup> would augment this number considerably. If the lymph contained but 5000 cells per c.mm. — the least found in any of our counts and the average number found by Rous in a series of 14 dogs — we should still have as many mononuclears entering the blood in the course of a day as are to be found there at any one time. According to these figures the mononuclear portion of the blood leucocytes is replaced by fresh cells, at least once and possibly three or four times, in the course of every twenty-four hours. What becomes of this army of leucocytes? I shall not attempt a full discussion of this question, but shall merely indicate a few possible explanations.

(1) They may be rapidly destroyed; <sup>27</sup> (2) they may develop <sup>28</sup> into, or degenerate into, <sup>5</sup> other "more advanced" forms, and be destroyed as such or undergo further unknown changes; (3) lymphocytes may be "reserve cells" <sup>10</sup> kept on hand to immediately combat injury to the tissues, and hence may be rapidly used in the repair processes necessitated by the constant wear and tear of daily life; (4) they may circulate from lymph, by way of the thoracic duct and neck lymphatics, to blood, and from blood, through the capillary endothelium, into the tissue lymph, and thence back into the lymph of the larger lymphatic trunks. In this connection it is interesting to note that lymphocytes have been seen in the act of passing through vessel walls. <sup>30</sup>

As none of these explanations can be fully accepted in the light of our present knowledge, and as all of them are open to more or less serious objections, we can conclude merely that many more lymphocytes (mononuclear leucocytes) enter the blood in the course of a day than can be found there at any one time and that the fate of the lymphocyte is unknown.

IV. How is the co-ordination between the number and kinds of leucocytes in the neck and thoracic lymph and the blood maintained? In order to answer this question we must know (1) the factors which govern the rate of the passage of leucocytes, or, better, lymphocytes, since they are the predominating cells, from lymph to blood, and (2) the factors which determine the rate of removal of lymphocytes from the blood,— in other words, the fate of the lymphocyte.

(1) The rate of the passage of lymphocytes from lymph to blood is probably, under normal conditions, dependent upon the rate of lymph flow and the massage effect of muscular contraction. <sup>7</sup> It seems probable that the rate of formation of lymphocytes in the lymph glands is more or less constant. Thus, it has been shown that there are no evidences of increased activity in the adenoid tissue of the intestinal wall during digestion <sup>32</sup>— a process which is accompanied by a leucocytosis which is mainly a lymphocytosis associated with an increased rate of lymph flow from the thoracic duct — and Rous <sup>7</sup> has shown that, provided the animal is kept perfectly quiet, the number of leucocytes in the thoracic lymph remains at a practically constant level for a period of a few hours at least. His experiments were not carried further. In addition, it has not been shown that lymphagogues cause an increased rate of cell division in lymphatic glands, although, as mentioned above, they not only

cause an increased flow of lymph, but an increase in the cellular content of lymph; also, it seems highly probable that such drugs as pilocarpine, muscarine, barium chloride, and adrenaline produce an absolute lymphocytosis, not by stimulating the lymph glands to increased activity, but by their lymphagogue action and by their effects in causing the contraction of the smooth muscle of the lymphatics, spleen,<sup>8</sup> and intestines.<sup>7</sup> Massage causes an increased lymph flow and an increased cell content of the lymph—still one hardly expects such manipulations to stimulate the cells of the lymph glands to multiply to any great extent. Lymphocytes probably tend to accumulate in the lymphatic system when the lymph flow is slow and scanty, to be washed out as the stream of lymph becomes more brisk and voluminous. (2) The factors which determine the rate of removal of lymphocytes from the blood, as stated in a previous paragraph, are unknown. We can, therefore, answer only the first half of our question.

#### SUMMARY.

The blood of normal dogs contains about 20,000 leucocytes per c.mm. Polymorphonuclear leucocytes form about 75 per cent of this number, while the mononuclear leucocytes constitute about 25 per cent. Eosinophile leucocytes vary in number from 0 in a count of 1000 cells, to 11.2 per cent in a count of 142 cells. Some authors have found as high as 21 per cent.<sup>23</sup> The amount and kind of food is important with respect to these variations.

The thoracic lymph of normal dogs contains from 1000 to 30,000 leucocytes, 95 per cent to 100 per cent of which are small lymphocytes. A few large mononuclear leucocytes occur frequently (5.2 per cent, Rous), but their number is by no means constant. Eosinophile leucocytes are rare and subject to wide variations in number, probably secondary to variations in the diet. Mast cells are absent. Polymorphonuclear leucocytes occur only as evidence of blood admixture. The variations in the total number of leucocytes depend normally upon the state of activity of the animal in addition to other states which normally are accompanied by increased lymph flow. By rapid breathing or struggle the number of cells is greatly increased; by massage of the abdomen the number of cells in the lymph may be immediately increased from two to five times without change in the relative number of the kinds of

cells. This increase is probably dependent upon a flushing out of the lymphatics by quickened lymph flow, plus the mechanical squeezing of the lymphocytes into the lymph stream. The number of cells tends to decrease after prolonged massage.

The neck lymph contains about the same number of leucocytes as the thoracic lymph. The variation in the number of leucocytes here of course depends upon localized head or neck activity rather than upon the activity of limbs, trunk, and viscera. Practically 100 per cent of the leucocytes of the neck lymph are small mononuclears; mast cells are absent; polymorphonuclear leucocytes occur only as evidence of blood admixture; eosinophiles are rare. Massage greatly increases the cell content of the neck lymph, without change in the relative number of the kinds of cells.

The distinction between the number of leucocytes found floating in the lymph, and the number actually bathed in the lymph, should be borne in mind.

The tying off of lymphatic trunks, the making of fistulæ of thoracic ducts, and the removal of important groups of lymph glands are said to cause a great decrease in the number of lymphocytes in the blood. Such experiments should always be controlled by total as well as differential blood counts, since the mere ligation of lymphatics does not prevent a polymorphonuclear leucocytosis which would make uncontrolled differential counts misleading.

We cannot explain the variations in the relative concentration of enzymes and antibodies in blood, thoracic lymph, and neck lymph upon the basis of variations in the leucocytic content of these fluids. Enzymes and antibodies appear to vary independently of leucocytes.

Many more lymphocytes enter the blood with the lymph in the course of twenty-four hours than can be found in the blood at any given time. The fate of the lymphocyte and the full explanation of the means by which the co-ordination in leucocytic content is maintained between blood, neck lymph, and thoracic lymph, is unknown. We may say in part that the rate of the entrance of lymphocytes into the blood is probably dependent upon the rate of lymph flow, and the massage effect of muscular contraction, but that the means by which the accumulation of lymphocytes in the blood is prevented has not been demonstrated.

A sufficient number of lymphocytes enter the blood with the thoracic and neck lymphs to account for all such cells found in the blood. This

fact, coupled with those learned by studies of the blood following ligation of the thoracic duct and neck lymphatics, the establishment of thoracic duct fistulae, the removal of important lymph glands, and the administration of lymphagogues and drugs, seems to make it plain that normally, lymphocytes enter the blood with the lymph stream, and not by direct migration through the capillary walls from their place of formation. Lymphocytes are not the "casual quests" <sup>31</sup> of the lymph. They are as much a part of the lymph as the erythrocytes and leucocytes are of the blood.

Red blood cells are not to be regarded as normal constituents of the lymph.

#### BIBLIOGRAPHY

- <sup>1</sup> WEIDENREICH: *Anatomischer Anzeiger*, 1907, xxx, p. 51.
- <sup>2</sup> ROUS: *Journal of experimental medicine*, 1908, x, p. 537.
- <sup>3</sup> LEAF: *Lancet*, 1900, i, p. 606.
- <sup>4</sup> WINTERNITZ: *Archiv für experimentelle Pathologie und Pharmakologie*, Leipzig, 1895, xxxvi, p. 213.
- <sup>5</sup> HAEDICKE: *Folio haematologica*, 1906, iii, p. 527.
- <sup>6</sup> EHRLICH: NOTHNAGEL'S *System of medicine*, 1905. See ROUS, *Journal of experimental medicine*, 1908, x, p. 238.
- <sup>7</sup> ROUS: *Journal of experimental medicine*, 1908, x, p. 238.
- <sup>8</sup> HARVEY: *Journal of physiology*, 1906, xxxv, p. 115.
- <sup>9</sup> HAYEM: *Comptes rendus de la Société de Biologie*, 1899, li, p. 621.
- <sup>10</sup> SELINOFF: *Archives des sciences biologiques*, 1903, x, p. 273.
- <sup>11</sup> BIEDL and v. DECASTELLO: *Archiv für die gesammte Physiologie*, 1901, lxxxv, p. 259.
- <sup>12</sup> CRESCENZI: see BANTI, *Folio haematologica*, 1904, i, p. 418.
- <sup>13</sup> EHRLICH and REINBACH: see DELAMERE, *The lymphatics*, p. 40.
- <sup>14</sup> RANVIER: *Traité technique d'histologie*, 1875-1882, p. 169.
- <sup>15</sup> MILLER: *Journal of pathology and bacteriology*, 1904, x, p. 1.
- <sup>16</sup> CLELAND: *Transactions of the Pathological Society of London*, 1905, lvi, p. 381.
- <sup>17</sup> BANTI: *Folio haematologica*, 1904, i, p. 418.
- <sup>18</sup> EMERSON: *Clinical diagnosis*, 1906, p. 483.
- <sup>19</sup> GREER and BECHT: *Proceedings of the Society of Experimental Biology and Medicine*, 1909, vi, p. 59.
- <sup>20</sup> STEWART: *Manual of physiology*, 1907, p. 50.
- <sup>21</sup> OPIE: *American journal of the medical sciences*, 1904, cxxvii, p. 217.
- <sup>22</sup> HEIDENHAIN: *Archiv für die gesammte Physiologie*, 1888, xliii, p. 1, Supplementheft.
- <sup>23</sup> BURNETT: *Clinical pathology of the blood of animals*, 1908, chap. iii, p. 45.
- <sup>24</sup> CARLSON and GREEN: Personal communication.
- <sup>25</sup> HOWELL: *Text-book of physiology*, 1907, p. 437.



- <sup>26</sup> HEIDENHAIN: *Archiv für die gesammte Physiologie*, 1891, xlix, p. 215.
- <sup>27</sup> HORBACZEWSKI: *Sitzungsberichte der Kaiserliche Akademie der Wissenschaften zu Wien, Mathematisch-naturwissenschaftliche Classe*, 1890-1891, xcix-c, Abt. iii, p. 478.
- <sup>28</sup> GULLAND: *British medical journal*, 1904, ii, 583-605.
- <sup>29</sup> ROUS: *Journal of experimental medicine*, 1908, x, p. 329.
- <sup>30</sup> SCHRIDDE: *Münchener medicinische Wochenschrift*, 1905, lii, pp. 1862-1864.
- <sup>31</sup> DELAMERE: *The lymphatics*, translated by Leaf, 1904.
- <sup>32</sup> PATON, GULLAND, and FOWLER: *Journal of physiology*, 1902, xxviii, p. 83.
- <sup>33</sup> BRAUDE and A. J. CARLSON: *This journal*, 1908, xxi, p. 221.
- <sup>34</sup> W. T. HUGHES and A. J. CARLSON: *This journal*, 1908, xxi, p. 236.
- <sup>35</sup> CARLSON and LUCKHARDT: *This journal*, 1908, xxiii, p. 148.
- <sup>36</sup> WARTHIN: *American journal of anatomy*, 1902, i, p. 63.

TABLE I.  
Blood.

Dog.	Leucocytes per c.mm.		Mononuclear.		Polymorphs.		Eosinophiles.		Degenerating.		No. cells counted.	Remarks.
	Free flow.	Mass.	Absolute.	Per cent.	Absolute.	Per cent.	Absolute.	Per cent.	Absolute.	Per cent.		
I	17,500	...	283	28.9	680	69.4	16	1.6	0	0.0	979	.....
II	19,166	...	...	...	...	...	...	...	...	...	...	No differential made.
III	18,750	...	22	15.5	104	73.2	16	11.2	0	0.0	142	.....
IV	...	...	56	23.0	179	74.89	4	1.2	0	0.0	239	.....
V	...	...	65	25.0	190	73.0	3	1.1	0	0.0	258	.....
VIII	42,631	...	186	16.1	961	83.3	0	0.0	6	0.5	1153	Dog thin, weak, sick. Bacilli found in thoracic lymph.
IX	...	...	149	28.13	379	71.5	2	0.37	0.0	0.0	530	.....
X	...	...	115	21.33	424	78.47	0	0.0	0	0.0	539	.....
XI	...	...	55	27.5	14.4	72.0	0	0	1	0.5	200	.....

TABLE II.  
THORACIC LYMPH.

Dog.	Leucocytes per c.mm.		Mononuclear.		Polymorphs.		Eosinophile.		Degenerating.		No. cells counted.	Remarks.
	Free flow.	Mass.	Absolute.	Per cent.	Absolute.	Per cent.	Absolute.	Per cent.	Absolute.	Per cent.		
I	25,475	81,607	989	99.89+	0	0.0	1	0.1+	0	0.0	990	Red cells very rare.
II	27,500	65,000	965	95.7	0	0.0	0.0	0.0	43	4.2	1008	No red cells.
III	34,375	...	1000	99.0+	8	0.79	0	0.0	2	0.10	1019	Many red cells.
IV	...	...	1000	100.0	0	0.0	0	0.0	0	0.0	1000	No red cells.
V	...	...	500	96.5	0	0.0	0	0.0	18	3.4	518	No red cells.
VI	...	...	999	99.9	1	0.1	0	0.0	0	0.0	1000	A few red cells.
VII	...	...	1000	95.2	40	3.8	0	0.0	10	0.95	1050	Many red cells.
VIII	13,250	...	...	...	...	...	...	...	...	...	...	Smears lost.
IX	...	...	1000	95.1	48	4.6	0	0.0	0	0.0	1048	Many red cells.
X	...	...	1000	99.9	1	0.1	0	0.0	0	0.0	1001	Red cells rare.
XV	18,500	...	...	...	...	...	...	...	...	...	...	No differential made.

TABLE III.  
NECK LYMPH.

Dog.	Leucocytes per c.mm.		Mononuclear.		Polymorphs.		Eosinophile.		Degenerating.		No. cells counted.	Remarks.
	Free flow.	Mass.	Absolute.	Per cent.	Absolute.	Per cent.	Absolute.	Per cent.	Absolute.	Per cent.		
I	12,967	30,463	1000	100.0	0	0.0	0	0.0	0	0.0	1000	No red cells.
II	24,722	41,933	1044	100.0	0	0.0	0	0.0	0	0.0	1044	No red cells.
III	23,437	123,437	1000	99.4	1	0.099+	0	0.0	5	0.49+	1006	A few red cells.
IV	...	...	999	99.9	0	0.0	1	0.1	0	0.0	1000	A few red cells.
V	...	...	986	98.6	6	0.6	2	0.2	6	0.6	1000	Many red cells.
VI	...	...	220	93.1	0	0.0	0	0.0	16	6.8	236	Smears poor, counts discontinued.
VIII	No free flow	63,625	1000	99.8	0	0.0	0	0.0	2	0.2	1002	No red cells. Sick dog.
IX	...	...	1000	100.0	0	0.0	0	0.0	0	0.0	1000	No red cells.
X	...	...	1000	100.0	0	0.0	0	0.0	0	0.0	1000	No red cells.
XI	...	...	1000	100.0	0	0.0	0	0.0	0	0.0	1000	No red cells.
XV	5,000	11,000	...	...	...	...	...	...	...	...	...	No differentials made.

TABLE IV.  
THORACIC DUCT AND NECK LYMPHATICS LIGATED. BLOOD COUNTS.

No.	Dog.	No. leucocytes per c.mm.		Mononuclear.		Polymorphs.		Eosinophiles.		Degenerating.		Total no. cells counted.	Remarks.
		Free flow.	Mass.	Absolute.	Per cent.	Absolute.	Per cent.	Absolute.	Per cent.	Absolute.	Per cent.		
XII	Before operation . . . . .	42,500	...	...	...	...	...	...	...	...	...	...	Dog appeared apathetic and drowsy before operation. Apparently not entirely well.
	24 hrs. after operation . . . . .	47,500	...	457	40.1	658	57.8	0	0.0	23	2.0+	1138	
	48 hrs. after operation . . . . .	43,190	...	176	35.2	323	64.6	1	0.2	0	0.0	500	
XIII	Before operation . . . . .	19,062	...	113	22.6	378	75.6	9	1.8	0	0.0	500	Dog bright and healthy.
	8 hrs. after operation . . . . .	24,531	...	68	13.6	431	86.2	1	0.2	0	0.0	500	
	20 hrs. after operation . . . . .	24,552	...	61	10.03	446	87.7	1	0.19	0	0.0	508	
XIV	Before operation . . . . .	10,051	...	114	22.3	392	76.8	4	0.78	00	0.0	510	Dog bright and healthy.
	5 hrs. after operation . . . . .	9,344	...	...	...	...	...	...	...	...	...	...	
	18 hrs. after operation . . . . .	15,781	...	62	12.3	441	87.6	0	0.0	0	0.0	503	

## THE RELATIVE TOXICITY OF VARIOUS SALTS AND ACIDS TOWARD PARAMECIUM.

BY LORANDE LOSS WOODRUFF AND HERBERT HORACE BUNZEL.

[From the Marine Biological Laboratory, Woods Holl, Massachusetts.]

MANY investigations have been undertaken to determine the cause of the physiological action of salts upon protoplasm, but until quite recently the net result has been the fact that there is a certain relationship between the toxicity and the atomic or molecular weights of certain elements and compounds. The recent developments of the ionic theory have lent renewed interest to the problem, and the work of Kahlenberg and True, Heald, Krönig and Paul, Loeb, Mathews, Lillie, and others<sup>1</sup> has brought forward strong evidence to support the idea that the pharmacological action of a salt solution is to a considerable extent due to the ions into which the salt dissociates. Mathews has elaborated and emphasized the idea that atoms act by means of their electrical condition, and that positively and negatively charged ions have opposite action. Ions of the same sign act alike, but the degree of their action, *i. e.*, their specific toxicity, differs because the ease with which they change their electrical condition varies. The poisonous action of an element, then, depends largely, though probably not exclusively, upon the affinity of the atom for its electrical charge. Mathews has suggested the term "ionic potential" to indicate the tendency of any ion or atom to change its electrical state, *i. e.*, the inherent tendency of

<sup>1</sup> KAHLENBERG and TRUE: *Botanical gazette*, 1896, xxii, p. 81; HEALD: *Ibid.*, 1896, xxii, p. 125; KRÖNIG and PAUL: *Zeitschrift für Hygiene*, 1897, xxv, p. 1; CLARK: *Botanical gazette*, 1899, xxviii, p. 289; J. LOEB: *This journal*, 1902, vi, p. 411, etc.; MATHEWS: *Science*, 1902, xv, p. 492; *Ibid.*, 1903, xvii, p. 729; *This journal*, 1904, x, p. 290; *Ibid.*, 1904, xi, p. 455; *Ibid.*, 1905, xii, p. 419; *Studies by the Pupils of W. T. Sedgwick*, 1906, p. 80; MCGUIGAN: *This journal*, 1904, x, p. 444; R. LILLIE: *Ibid.*, 1904, x, p. 419; *Ibid.*, 1906, xvii, p. 89; CALDWELL: *Botanical gazette*, 1905, xxxix, p. 409; NICHOLL: *Journal of biological chemistry*, 1909, v, p. 453.

any ion in any concentration to change into an atom of its metal. We shall not discuss the underlying principles of this hypothesis and its theoretical elaboration, as this may be found in full in the several papers on the subject by that author.

Comparatively few experiments have been performed on animal organisms to determine if toxicity bears any direct relation to ionic potential. The most important results in this connection are those of Mathews on the developing eggs of *Fundulus heteroclitus*, and of Lillie on the cilia of *Mytilus* and the embryo of *Arenicola*. In the present paper we shall briefly summarize the results of a series of experiments carried out to determine the relative toxicity of a number of cations toward the protoplasm of *Paramecium aurelia*.

The ease with which *Paramecium* lends itself to experimental methods makes it one of the most favorable forms for general physiological study, and the fact that the organism consists of but a single cell eliminates many complications which arise in work on the developing eggs and adults of higher forms. For example, marked differences have been found in the toxic action of salts towards various tissues of the same animal, and towards the same tissue under different conditions; when, however, the organism is reduced to the lowest possible term, the single cell, these complications are considerably diminished if not entirely eliminated. Further, we had at our disposal a pedigree culture of *Paramecium* which was at about the 1300th generation at the time of the experiments. This culture was started in May, 1907, and has been under daily observation up to the present time. The rate of reproduction has been recorded each day.<sup>2</sup> This culture afforded us organisms whose physiological condition, as indicated by the fission rate, had been studied for more than two years, and whose status in the life "cycle" was known. The importance of this factor becomes evident in certain experiments on the effect of salts on the reproduction of infusoria<sup>3</sup> in which, for example, it was found that  $K_2HPO_4$ , N. 1250, produced different effects at different periods in the life "cycle." When the salt was first used, the vitality of the animals was somewhat greater than toward the end of the experiments, and the conclusion was reached that the difference in effect was due to this change in the vitality of the protoplasm.

<sup>2</sup> For further details of this culture see WOODRUFF: Biological bulletin, 1909, xvii, p. 287.

<sup>3</sup> WOODRUFF: Journal of experimental zoology, 1905, ii, p. 585.

During the progress of the experiments efforts were made to maintain the culture on as stable a medium as possible, because many investigators have found that protozoa reared under different conditions react differently. For example: Greeley,<sup>4</sup> in studying the effects of various chemicals on the protoplasm of *Paramecium*, found that the "maximal dilutions can only be approximate, as the action of identical solutions is not the same on paramecia from different cultures, because no two are exactly alike in respect to chemical composition and osmotic pressure."

The methods employed in the experiments were as follows: an individual *Paramecium* was isolated from the pedigree culture by means of a capillary pipet and placed on a depression slide with as little water as possible. This quantity of water, which was unavoidable, and may have amounted to 0.001 c.c., was to all appearances under the microscope the same in every case. While the organism was being watched under the microscope, the salt solution whose effect was being tested was dropped upon it from another pipet. This pipet was used exclusively for this purpose in all the experiments, and in exactly the same way, so as to insure practical uniformity in the size of the drops. To ascertain the exactness of the method, the toxicity of the salt was determined on successive days, and the agreement of the results proves the conditions of the experiments to be highly satisfactory because in every case the two series of experiments gave results which were essentially the same.<sup>5</sup> The length of time taken to kill the organism was recorded. The criterion of death was the stopping of cilia and the consequent loss of motion of the organism. It was possible to distinguish this point with great exactness, owing to the long familiarity of one of the writers in handling paramecia in the study of pedigree cultures. Our endeavor was to determine the concentration of any particular salt necessary to kill within two seconds one half of the organisms tested at a temperature of about 20° C. It was found advisable to make the time of subjection as short as possible in order to eliminate the possibility of the organisms becoming acclimated to the solution. At least ten determinations were made for each strength employed, and in cer-

<sup>4</sup> GREELEY: Biological bulletin, 1904, vii, p. 1.

<sup>5</sup> For illustration we cite the fatal molecular concentration determined on successive days for the first three salts employed: —  $\text{AgNO}_3$  — 0.00033 — 0.00033;  $\text{HgCl}_2$  — 0.00015 — 0.00020;  $\text{CuCl}_2$  — 0.00200 — 0.00250.



tain cases over one hundred determinations were made before the desired toxicity was secured.

TABLE I.

Salt or acid used.	Molecular concentration of fatal solution.	Equivalent concentration.	Ionic potential of cation.
AgNO <sub>3</sub> . . . . .	0.00033	0.00033	+1.163
HgCl <sub>2</sub> . . . . .	0.000175	0.00035	+1.080
CuCl <sub>2</sub> . . . . .	0.00225	0.0045	+0.668
FeCl <sub>3</sub> . . . . .	0.00020	0.00060	+0.314
HCl . . . . .	0.00029	0.00029	+0.107
H <sub>2</sub> SO <sub>4</sub> . . . . .	0.00016	0.00032	+0.107
PbCl <sub>2</sub> . . . . .	0.00025	0.00050	+0.179
NiCl <sub>2</sub> . . . . .	0.060	0.120	+0.112
CoCl <sub>2</sub> . . . . .	0.063	0.126	+0.107
CdCl <sub>2</sub> . . . . .	0.00225	0.0045	-0.089
ZnSO <sub>4</sub> . . . . .	0.125	0.25	-0.434
MnCl <sub>2</sub> . . . . .	0.10	0.20	-0.737
MgCl <sub>2</sub> . . . . .	0.12	0.24	-1.160
SrCl <sub>2</sub> . . . . .	0.12	0.24	-2.
CaCl <sub>2</sub> . . . . .	0.275	0.550	-2.26
KCl . . . . .	1.00	1.00	-2.92

In almost all of the experiments the chlorides of the metals were used. The solutions were made up approximately by weight, and their concentration was determined by quantitative methods. Silver nitrate and zinc sulphate were employed instead of the chlorides. The fact that a sulphate and a nitrate were used besides the chlorides does not render the results less comparable, because the ionic potential of the three anions used is very nearly the same. Moreover, Mathews has shown that the same concentration of the nitrate, sulphate, and chloride of sodium are required to stop the development of *Fundulus* eggs. This is also recognized by comparing the toxicity of sulphuric and hydrochloric acid as found by the writers.

The results of the experiments are given in the table on p. 193. The strengths of the solutions are expressed in terms of molecular concentration. "Equivalent concentration" means the molecular concentration times the number of charges on the positive ion in question.

The table shows the general parallelism between the smallest fatal concentration of the various cations and the ease with which they throw off their charge, *i. e.*, the ionic potential. As in the results of previous workers, there are certain metals which are not in the order of toxicity which would be expected from their potential. However, one must consider that the living cell is composed of a large variety of materials, each having specific affinities for the different ions. This point is particularly well illustrated by the work of Galeotti and others.<sup>6</sup> It is probable that the low toxicity of copper, for example, is based on differences of that sort.<sup>7</sup> Cadmium and ferric iron are also out of place, just as they have been found to be in their action on the eggs of *Fundulus* and on certain seedlings. Hydrogen is somewhat more toxic than one would expect on first thought, but this is probably due to the high migration-velocity of the hydrogen ions. The time required to kill an organism like *Paramecium* when a drop of a toxic solution is placed upon it, is obviously dependent not only on the time of interaction between the ions of the salt and the protoplasm of the animal but also on the rate of diffusion of the ions in question. The hydrogen ion travels with a velocity about six times as great as that of the other ions employed and should be expected to be more effective.

Apart from these few exceptions all of the cations tried follow the order of their ionic potential. The slight fluctuations noticeable are within the errors of the experiment and may not be considered as exceptions. For example, Zn, Mn, Mg, and Sr are so close together that we can lay no stress on their apparent differences of toxicity. Considered as a whole, the results of the experiments indicate a marked parallelism between the order of the toxicity of the various cations toward *Paramecium* and the ionic potential of the ions employed.

<sup>6</sup> GALEOTTI: *Zeitschrift für physiologische Chemie*, 1904, xl, p. 492, etc.; LA FRANCA: *Zeitschrift für physiologische Chemie*, 1906, xlvi, p. 481.

<sup>7</sup> BONAMARTINI and LOMBARDI: *Zeitschrift für physiologische Chemie*, 1908, lviii, p. 165.

## ON THE NUCLEO-ALBUMIN IN THE YOLK PLATELETS OF THE FROG'S EGG, WITH A NOTE ON THE BLACK PIGMENT.

By J. F. McCLENDON.

[From the Zoological Laboratory of the University of Missouri, and the Histological Laboratory of Cornell Medical College.]

IN a former paper<sup>1</sup> I gave the results of a partial analysis of the three layers into which the frog's egg is separated by centrifugal force. In a microscopical study of these layers it was found that the heavy or centrifugal layer contained practically all of the yolk platelets and all of the black pigment. Minute fat droplets clung to the yolk platelets and pigment granules; but besides these, there was very little of any other substance in the layer. As the pigment was very small in amount, and the fat could easily be extracted with ether, it was thought that an analysis of this layer after extracting with ether would be an index to the composition of the yolk platelets. Besides the fats, the desiccated heavy layer contained 6 per cent of a lecithin and 60 per cent of a proteid residue containing 1.33 per cent of phosphorus. From its phosphorus content and association with lecithin I concluded that this residue consisted of a vitellin or ichthulin-like body similar to the yolk proteids of birds and fish. However, as the residue contained also the black pigment, I determined to separate the yolk platelets and analyze them separately.

During the last breeding season of *Rana pipiens* (March) I obtained twenty-five females with ripe ovaries. As the yolk platelets are all formed before the eggs leave the ovary, there was no necessity of waiting for the eggs to be laid and rendered difficult to handle on account of the thick egg membranes, or jelly. As not much material could be handled at once, the females were divided into several lots. The ova-

<sup>1</sup> Cytological and chemical studies of centrifuged frog's eggs, *Archiv für Entwicklungsmechanik*, 1909, xxv, p. 247.

ries, on being removed from the living females, were freed from blood and immediately squeezed through bolting cloth to remove the ovarian stroma. This viscid egg mass was then either centrifuged, or a little water added and filtered through filter paper in a Buechner funnel with as much suction as two thicknesses of paper would stand. As filtration was very slow, and impossible without the addition of water or salt solution, an electric centrifuge was kept working to its full capacity and the filter used only for the surplus. The precipitate was washed several times by mixing with water containing a little phenol and separating again. Microscopical examination showed the precipitate to consist of yolk platelets, pigment granules, and adherent fat globules. All attempts to dissolve out the pigment in samples failed, so the yolk platelets had to be dissolved in order to separate them. The yolk platelets dissolve with extreme slowness in water containing any concentration of salts, but a little more quickly in alkalis. The material was placed in flasks with twenty volumes of water made alkaline with ammonia, and rotated for twenty-four hours or more. In testing this solvent under the microscope, the yolk platelets immediately swelled and became invisible, but filtration showed that they had only partially dissolved. The slightly turbid fluid portion was now separated by the above methods. It did not coagulate on boiling unless neutralized or acidified. The alkaline solution began to precipitate on three-eighths saturated ammonium sulphate and was thrown down completely on half saturation. Hen vitellin is insoluble in water, but forms a turbid solution in neutral salt solutions; it is soluble in one tenth per cent HCl, in dilute alkalis, and alkali carbonates. The ichthulins also differ slightly in solubilities from the yolk platelets of the frog. On account of these differences and difference in composition, I will call the proteid of the yolk platelets batrachiolin. Enough HCl was added to precipitate the batrachiolin, which was then dried in vacuo over  $H_2SO_4$ . The dried material was powdered and extracted with ether forty-eight hours and boiling alcohol forty-eight hours in a Soxhlet extractor, and desiccated again. The analysis is shown in Table I, with those of similar proteids for comparison. Sulphur and phosphorus were determined gravimetrically and nitrogen by a modified Kjeldahl method. Six per cent of lecithin was associated with the batrachiolin in the yolk platelets.

Native nucleoproteids contain 0.5 to 1.6 per cent of phosphorus.<sup>2</sup>

<sup>2</sup> HALLIBURTON: *Journal of physiology*, 1894, xvii, p. 135; xviii, p. 306.

In Table I it will be seen that this is about the concentration of phosphorus in the yolk proteids of fish, frogs, and birds. This lends support to the view that the plastic materials used in the growth of nuclei in the development of the egg are the vitellin-like substances. The lecithins have a higher per cent of phosphorus (2-4 per cent), and if

TABLE I.

Yolk proteid (dry).	Phosphorus.	Sulphur.	Nitrogen.
	per cent.	per cent.	per cent.
Batrachiolin . . . . .	1.208	1.32	15.14
Perch ichthulin . . . . .	0.74	1.13	14.8 <sup>1</sup>
Carp ichthulin . . . . .	0.43	0.41	15.64 <sup>2</sup>
Cod ichthulin . . . . .	0.65	0.92	15.96 <sup>3</sup>
Hen vitellin . . . . .	0.94	1.04	16.38
Hen vitellin . . . . .	0.35	0.88	(Osborne & Campbell) 16.97 (Gross)

<sup>1</sup> HAMMARSTEN: Skandinavisches Archiv für Physiologie, 1905, xvii, p. 113.  
<sup>2</sup> G. WALTER: Zeitschrift für physiologische Chemie, 1891, xv, p. 477.  
<sup>3</sup> P. A. LEVENE: *Ibid.*, 1901, xxxii, p. 281.

they contribute toward the formation of nuclei, they do so in association with other substances. If one considers a vitellin as a proteid-lecithin compound, perhaps the whole goes into the formation of nucleo-proteids.

NOTE ON THE BLACK PIGMENT.

An attempt was made to obtain the black pigment pure for analysis. It was impossible to dissolve out the last trace of batrachiolin, even by agitation with alkaline water for days. The pigment partially dissolves in concentrated alkalis, forming a brown solution, but not at all in dilute alkalis. The purest sample I obtained contained 0.483 per cent of phosphorus, 0.832 per cent of sulphur, and 10.9 per cent of nitrogen. As practically all black animal pigments contain no phosphorus, it is probable that the phosphorus is due to the presence of batrachiolin. This would mean that the sample was about one third batrachiolin, and subtracting this would leave 0.6 per cent of sulphur and 9 per cent

of nitrogen in the constitution of the pigment. This may be compared with the melanin, sepia, containing 0.52 per cent sulphur and 12.3 per cent nitrogen.<sup>3</sup> Some melanoidins contain as low as 8 per cent nitrogen and some as high as 0.9 per cent sulphur.

<sup>3</sup> NENCKI and SIEBER: *Archiv für experimentelle Pathologie und Pharmakologie*, 1888, xxiv, p. 17.

## THE CATALASE OF ECHINODERM EGGS BEFORE AND AFTER FERTILIZATION.<sup>1</sup>

BY E. P. LYON.

[*St. Louis University School of Medicine.*]

SINCE the attention of bio-chemists has been directed to the enzymes as important factors in life phenomena, the suggestion that the fertilization of the ovum is due to the introduction of catalyzers or to some change in those already present in the egg has frequently been advanced. A formulation and discussion of some of the possibilities will be found in Loeb's "Dynamics of living matter,"<sup>2</sup> where also are references to his original papers and to other literature on this subject. The attempts to cause the development of unfertilized eggs by treating them with extracts of sperm have since Gies'<sup>3</sup> careful work been recognized as futile.

In 1906 Terry and I made comparative tests of the catalase of Echinoderm (*Arbacia*) eggs and came to the apparent conclusion that there was a larger amount of this enzyme before than after natural fertilization. Our method consisted in the shaking of the eggs with sand in the presence of an antiseptic until a supposed uniform suspension was obtained. The filtered extract of this suspension was tested with hydrogen peroxide, the oxygen set free being measured. I made a tentative report of these experiments to the International Physiological

<sup>1</sup> The experimental work of this paper was done chiefly during June and July, 1909, at the laboratory of the U. S. Bureau of Fisheries, Beaufort, N. C. A few experiments were done at Woods Hole. During part of this period the writer had the advantage of an appointment on the staff of the Bureau. For this and many other acts of courtesy and assistance on the part of the Commissioner, the Hon. George M. Bowers, and the Directors of the Beaufort and Woods Hole Laboratories, Mr. H. D. Aller and Dr. F. B. Sumner, respectively, hearty acknowledgment is made.

<sup>2</sup> J. LOEB: *Dynamics of living matter*, New York, 1906, pp. 175 *et seq.*

<sup>3</sup> GIES: *This journal*, 1901, vi, p. 53.

Congress<sup>4</sup> at Heidelberg in 1907. The discovery that the lipolytic power was also greater in extracts so made from unfertilized than from fertilized eggs aroused doubt in our minds as to the adequacy of our methods; and upon repeating the work the next summer we became convinced that, while the unfertilized eggs are easily disintegrated, those which have been fertilized resist to a greater degree the cutting action of sand, and comparisons cannot be instituted between preparations of fertilized and unfertilized eggs after equal shaking according to our method. We wish, therefore, to record the error of our former tentative conclusions. Since this early work of Terry and myself there has appeared a long paper by Wolfgang Ostwald<sup>5</sup> containing the results of his investigation of the peroxidase and catalase in the eggs and sperm of amphibians. The catalase content of sperm was found, weight for weight, to be greater than that of eggs, an observation which A. P. Mathews tells me he has made for the sea urchin. Ostwald did not make comparative tests of eggs before and after fertilization. He tried mixtures of egg and sperm extracts and obtained only additive results except in one experiment. In this case the mixture had stood for several hours, and an increase in peroxide splitting amounting to 23 per cent over the calculated amount was noted. More experiments of this nature are desirable.

In Ostwald's paper will also be found a discussion of the theoretical aspects of fertilization in its relation to enzyme activities.

O. H. Brown<sup>6</sup> has published a short note on experiments performed by him on the enzymes of the ova and sperm of starfish. He was not able to get concordant results with mixtures of the two. Brown's experiments, although not published until this year, appear to have been the first in which the interrelation of sperm and egg enzymes was investigated.

The experiments to be described in this communication were undertaken in the hope of clearing up the results formerly secured by Terry and myself. At the Beaufort laboratory of the U. S. Fisheries Bureau I had the advantage of an unlimited amount of sea urchin material. *Toxopneustes* and *Arbacia* were used, both genera giving the same results.

<sup>4</sup> LYON and TERRY: Zentralblatt für Physiologie, 1907, xxi, p. 476.

<sup>5</sup> WOLFGANG OSTWALD: Biochemische Zeitschrift, 1907, vi, p. 409.

<sup>6</sup> BROWN: Science, N. S., 1909, xxix, p. 824.



METHODS.

Bearing in mind the difficulties formerly encountered in obtaining extracts by the shaking method, and being without facilities for obtaining press juice by the Buchner process, I decided to use the entire eggs. As these are minute and separate cells, I had at least the advantages of uniformity and of freedom from supporting tissues which constitute an error when one works with entire sex organs. The greatest disadvantage was the inability of knowing how thoroughly the enzyme was set free or came in contact with the peroxide. This makes my results difficult of interpretation. Another disadvantage of dealing with a suspension of eggs instead of a solution is the constant tendency of the eggs to settle. By care, however, to keep the suspensions thoroughly stirred, no great error is introduced. Tests with the same suspension, for example, show very uniform results if one adopts the precaution of thoroughly mixing and quickly measuring out the volumes to be used.

The apparatus employed was practically the same as Loewenhart's.<sup>7</sup> The vials for the peroxide were cemented in the bottles at an angle so that a slight tip would spill the peroxide and mix it with the eggs. Five of the apparatuses were arranged side by side, the bottles being fastened together so that all could be tipped to mix the eggs and peroxide at the same moment. The bottles were shaken throughout the experiment, readings of the burettes being made in most experiments at two and four minute intervals. In some cases readings were made at minute intervals, and in some instances the readings were continued longer than four minutes. The usual charge consisted of 25 c.c. of a suspension of eggs or sperm and 5 c.c. of peroxide. Of the latter the commercial quality as put out by the Mallinckrodt Chemical Co. was employed. In some of the work the acidity was neutralized. In other cases the unneutralized peroxide was used. I find that I have no comparative results of the effects of the acidity of the peroxide on the same lot of eggs. The data published in this article were obtained with unneutralized peroxide.

The usual form of experimenting was as follows: The eggs were taken from the females and allowed to settle several times in renewed, large quantities of sterile sea water. They were thus freed as well as

<sup>7</sup> LOEWENHART: This journal, 1905, xiii, p. 171.

possible from immature eggs, body cells and other material. A large volume of fertile eggs suspended in sea water was divided into a number of equal lots. Care was taken to have these uniform by constant agitation while the measuring was going on. These lots were fertilized

TABLE I

TRIAL 1.					
3.23	A (13')	B (8')	C (3')	Unfert.	Sperm.
2'	10.2	8.0	4.3	4.3	22.7
4'	18.4	15.2	8.5	8.8	34.6
TRIAL 2.					
3.32	A (22')	B (17')	C (12')	D (7')	E (2')
2'	10.3	10.1	9.1	7.8	4.5
4'	17.7	17.2	15.8	14.1	8.8
TRIAL 3.					
3.42	C (22')	D (17')	E (12')	F (7')	G (2')
2'	9.5	10.1	9.6	5.6	4.4
4'	16.4	17.3	16.7	10.6	8.6
TRIAL 4.					
3.51	E (21')	F (16')	G (11')	H (6')	J (1')
2'	8.7	8.5	8.0	6.0	4.1
4'	15.1	14.6	13.9	11.1	8.4
TRIAL 5.					
4.01	G (21')	H (16')	J (11')	Unfert.	Sperm.
2'	9.1	7.7	8.0	3.9	19.6
4'	15.2	13.2	13.7	7.5	31.2

at regular intervals, the usual one being five minutes. Five of these lots were tested for catalase at each trial.

The method of conducting experiments will be better understood from the table of results obtained in actual experiments:

*July 23, 1909.*—A quantity of *Toxopneustes* eggs divided into 10 lots of 55 c.c. each. Nine lots were fertilized as follows: Lot A at 3.10; B, at 3.15; C, at 3.20; D, at 3.25; E, at 3.30; F, at 3.35; G, at 3.40; H, at 3.45; J. at 3.50. In fertilizing each lot 1.2 c.c. of sperm was added. Lot K was unfertilized. In each trial 25 c.c. of eggs or sperm were used and 5 c.c. peroxide. Letters at the heads of columns indicate the lots of eggs. Numbers in parentheses indicate number of minutes each had been fertilized at time trial was made. Time in first column is that at which trial is begun. Readings in each trial indicate cubic centimetres of oxygen set free in two and four minutes, respectively, after the cells and peroxide were mixed (see Table I).

*July 1, 1909.*—Suspension of *Arbacia* eggs divided into lots of 100 c.c. each, which were fertilized as follows: Lot A at 3.50; B, 4.02; C, 4.14; D, 4.26; E, 4.40; F, 4.52; G, 5.05; H, 5.17; in each trial 20 c.c. of eggs and 5 c.c. of H<sub>2</sub>O<sub>2</sub> were used. Table arranged as in the previous experiment. Only one of eight trials is given. The others gave similar results.

TABLE II.

TRIAL 3.					
4.44	A (54')	B (42')	C (30')	D (16')	E (4')
2'	11.2	11.3	9.2	7.6	6.1
4'	17.7	18.4	16.2	14.4	11.9

*July 2, 1909.*—Seven lots of *Toxopneustes* eggs fertilized at fifteen-minute intervals as follows: Lot A, 10.20; B, 10.35; C, 10.50; D, 11.05; E, 11.20; F, 11.35; G, 11.50. With these six trials were made as in preceding experiments. The results of only one trial are given. The rest are similar, showing the great increase between the two-minute and seventeen-minute specimens, but no constant difference between the others (see Table III).

Consideration of Tables I, II, and III discloses several striking results. The quantity of oxygen set free by the eggs increases tremendously a few

minutes after fertilization. In Table I the oxygen liberated by eggs twenty minutes after fertilization is about double that set free by the same quantity of unfertilized eggs. This change does not begin till a few minutes — about three — following the addition of sperm. The peroxide splitting power rapidly increases, and ten minutes after fertilization it is almost to a maximum. After fifteen minutes (shown clearly by other experiments, see Tables II and III) there is practically no increase in the catalytic power. The most rapid increase, as shown by other experiments in which eggs were fertilized at shorter intervals, is between four and seven minutes following fertilization.

TABLE III.

TRIAL 3.					
11.22	A (62')	B (47')	C (32')	D (17')	E (2')
2'	19.0	19.9	20.0	19.1	7.2
4'	27.5	28.5	28.7	27.8	12.7
6'	33.0	34.1	34.3	33.5	18.4

In studying the tables one may make comparisons within the same trial, say A, B, C, D, and E in trial 2, Table I, which had been fertilized respectively twenty-two, seventeen, twelve, seven, and two minutes when the trial was begun, or he can compare the results obtained with different samples of the same lot of eggs, say C in the first, second, and third trials of Table I. Either way the results are conclusive.

That the increase is not due to the catalase carried in by the sperm is apparent from two considerations. First, in the experiment summarized in Table III, in any 25 c.c. of fertilized eggs less than 0.2 c.c. of sperm is present, containing an amount of catalase too small to be appreciated by the method employed. Second, if we consider (let us say) the second trial, Table I, there is as much sperm in lot E as in A, yet the latter sets free 17.7 c.c. of oxygen in four minutes to 8.8 c.c. from the former. Evidently we have to do with a change brought about by the process of fertilization itself.

That the same change, though in a less degree, goes on in the fertilized *Arbacia* egg is apparent from Table II.

IS THERE A RHYTHMICAL CHANGE IN CATALASE CORRESPONDING TO EACH CELL DIVISION?

Having established the great increase in peroxide splitting ability of eggs following fertilization, I made experiments to ascertain whether changes in this power occurred at each cleavage. This phase of the question was the more interesting, since I have noted rhythmical changes in susceptibility to poisons, lack of oxygen, heat and cold.<sup>8</sup>

The method of experimenting will be sufficiently plain from preceding experiments, and tabulated results need not be given. If one, for example, compares eggs fertilized respectively forty-two, forty-seven, fifty-two, fifty-seven, and sixty-two-minutes, he will in the forty-two-minute specimen, at ordinary Beaufort temperatures, have eggs just going into the two-cell stage, while in the sixty-two-minute specimen they will be about ready for the second division. The others will be at various stages between the first and second cleavages. Such experiments show no constant difference in oxygen set free. If there is a rhythmical change in catalase action, it is within the limit of error of the method employed. One may conclude, therefore, that if the catalase increase following fertilization is of any special importance it is for fertilization, as distinguished from cleavage. The early appearance of the increase, considerably before the processes of cell division set in, is evidence for the same conclusion.

COMPARISON OF EARLY AND LATER STAGES.

No accurate comparison between the catalase of stages of development far apart is possible because there are always more or less unfertilizable eggs and unused sperm present, to say nothing of other impurities. Among these, bacteria soon began to grow. If one avoids this by removing the larvæ to fresh sea water, he cannot compare suspensions of these with the original eggs because of the absence in the former of the eggs which failed to develop and whose presence in the latter adds to their peroxide splitting power. The catalase action of a suspension of unfertilized eggs or of sperm decreases rather rapidly up to the time when bacteria become abundant; then it increases again. In general, com-

<sup>8</sup> LYON: This journal, 1902, vii, pp. 56 *et seq.*

parison of eggs fertilized, say half an hour, with those which had been fertilized three or four hours showed less catalase in the latter specimen. But one cannot be sure that this is not due to the decrease of power in the unfertilizable eggs present. It is certain that no great changes like that shortly following fertilization occur at any later stage in development.

#### THEORETICAL CONSIDERATIONS.

Regarding the increase in catalase, real or apparent, following fertilization, several views may be held.

We may assume that the sperm carries in a kinase-like substance which activates or sets free catalase in the egg. This is a fascinating conception. Any facts supporting it would tend to bring fertilization into the category of enzyme activities. But this theory demands unimpeachable experimental proof. Loewenhart has shown how cautious one should be in regard to the assumption of kinase action.

If the peroxide catalysis should be looked upon as an accidental property of bodies serving quite different functions in the cell,—a view which some have advanced,—the increase in catalase following the entrance of the sperm into the egg might be considered merely as an expression of increased activity in the fertilized egg, leaving the nature of these processes as far from solution as ever. The absolute differentiation in an experimental way between this view and the first would be difficult or impossible at present.

A view not to be disregarded is that we are dealing with an apparent rather than a true increase in catalase, and that the real change is one of permeability by which the peroxide and catalase come more readily together after fertilization.

The supposition that the increase is due to catalase carried in by the sperm may be discarded, in the opinion of the writer, for reasons already given.

The remaining experiments were performed in an effort to decide between the first theory, that of a kinase carried into the egg, and the third theory that the observed effects were due to a change of permeability.

EFFECT OF DISTILLED WATER.

If distilled water be added to sea urchin eggs, it is well known that they swell and burst open. The contents go more or less into solution. Experiments were made with *Toxopneustes* unfertilized eggs to which from one to three volumes of water were added, compared with similar suspensions diluted with the same volume of sea water. About twice as much peroxide was catalyzed by the former as by the latter suspensions. While the water might possibly of itself activate the enzyme, the simplest explanation is that the enzyme and peroxide came into contact better after the breaking or solution of the protoplasmic membranes.

When one attempts to compare fertilized eggs treated with distilled water with unfertilized eggs treated in the same way, the difficulty encountered is that the water does not affect the two equally nor in the same length of time. Nor does the water affect the fertilized eggs equally at all stages between fertilization and the first cleavage. Starting with equal suspensions of fertilized and unfertilized eggs, it was observed that, soon after the addition of distilled water, the unfertilized eggs in some experiments might split peroxide as rapidly (see Table IV) as the fertilized. Indeed, sometimes the action of the unfertilized eggs after treatment with distilled water exceeded, for a time, that of the fertilized, thus giving results corresponding to those of Terry and myself already mentioned. The differences were not striking, however, and some little time after the addition of distilled water, in the clearest experiments, the fertilized again exceeded the unfertilized eggs in catalytic power. But the differences here were not nearly so great as those between the normal fertilized and unfertilized eggs in sea water. In other words, the effect of the addition of distilled water was a real or apparent increase of catalase in both fertilized and unfertilized eggs, but in the latter much more than in the former.

A complication which here prevented accurate comparisons was the rapid deterioration of the suspensions after the addition of distilled water. It seemed that a suspension of unfertilized eggs began to lose its catalase before the fertilized had reached a maximum. The use of ice-cold solutions might have given better results, but unfortunately no such experiments were made, being postponed for later trial at Woods Hole, where lack of material prevented effective work.

## EFFECT OF FREEZING.

A lot of *Tovopneustes* eggs, fertilized some time before, was compared with the unfertilized control, and then both were kept frozen solid for an hour. Freezing kills the eggs. After gradual thawing and return to room temperature, the catalase content was tested and found increased in both. The greatest increase was in the unfertilized; but this lot was not yet (in one trial) equal in catalytic action to the fertilized. In a later trial the suspensions gave equal results, the fertilized having apparently decreased in catalytic power. The experiment was performed only once.

## EFFECT OF HEATING.

Twenty cubic centimetres of eggs were fertilized, and fifteen minutes later they were poured into 60 c.c. of sea water at 45° C. At the same time 20 c.c. of unfertilized eggs were similarly treated. The highest temperature of the mixture was about 40° C. The duration of heating was about ten minutes. The catalase action of the unfertilized heated eggs was found to have increased one third to one half; that of the fertilized heated eggs, about one sixth. The latter was stronger than the former, as before heating, though not to the same extent. Experiment performed once; two trials of same material made at two-hour intervals; like results from both trials.

## EFFECT OF ANTISEPTICS AND ANÆSTHETICS.

The addition of formaldehyde, corrosive sublimate, or copper sulphate led to such rapid deterioration of catalase that no comparisons of value between fertilized and unfertilized eggs could be instituted.

No concordant results could be obtained with sodium fluoride, probably on account of the precipitation to a large extent of the fluorine ions by the sea water.

If 10 c.c. of 10 per cent chloral solution be added to each 90 c.c. of suspension of eggs, development is stopped. The peroxide splitting power of such suspensions, whether unfertilized, just fertilized, or fertilized for some time, remains about as it was before the anæsthetic was



added. After a time the catalytic activity is increased and to a greater extent (or at least earlier) in the unfertilized than in the fertilized eggs. In other words, the action is like that of distilled water. Probably the action is similar, *i. e.*, absorption of water. This strength of chloral was not sufficient to prevent bacterial growth.

If two volumes of a saturated solution of chloretone in distilled water be added to suspensions of eggs, the catalase content of fertilized eggs (in a single experiment) appeared to be more than doubled, the effect being apparently somewhat greater than that obtained by addition of distilled water alone. The catalytic power of unfertilized eggs so treated increased nearly fourfold and was equal to that of equivalent suspensions of fertilized eggs similarly treated.

#### MIXTURES OF EGGS AND SPERM WITHOUT FERTILIZATION.

The following experiment was performed:

*July 10.* — Four lots of 100 c.c. each of *Toxopneustes* eggs were fertilized as follows: Lot A at 11.15; B, 11.20; C, 11.25; D, 11.30. At 11.30, 25 c.c. of each lot were measured out for trial 1 (Table IV), and to the remaining 75 c.c. of each lot an equal quantity of distilled water was added. These lots were then designated AX, BX, etc. At the same time a quantity of unfertilized eggs was treated with an equal volume of distilled water, and a quantity of sperm was treated in the same way. These were designated "Unfert. X" and "Sperm X" respectively. In trials 3 and 4 sea water (S. W.) was used for comparison in diluting half charges of eggs and sperm. In each trial 25 c.c. of suspension and 5 c.c.  $H_2O_2$  were used in each bottle. Other features of Table IV same as Table I.

Trial 1 illustrates the usual increase of peroxide splitting power following fertilization.

Trial 2, Cols. 1, 2, and 5, illustrates the augmenting effect of distilled water already spoken of. (It is to be remembered that on account of the dilution only half as many eggs were used in trial 2 as in trial 1.) In this case all the eggs, whether unfertilized, just fertilized, or for some time fertilized, became equal in catalytic power soon after addition of water, although trial 1 showed they were very unequal before it was added.

Trial 2, Cols. 3, 4, and 5, and trials 3 and 4 seem to indicate that the mixtures of sperm and eggs without fertilization show peroxide splitting greater than would be expected from addition of their individual effects.

In trials 3 and 4, Col. 1 shows the effect of 25 c.c. Sperm X and Col. 5 of 25 c.c. of Unfert. X.

Col. 4 shows that the catalytic power of a mixture of Sperm X and Unfert. X, each one half, is greater than half the sum of the results of Cols. 1 and 5. Cols. 2 and 3 show the oxygen catalyzed by dilutions of Sperm X and Unfert. X, respectively, with equal volumes of sea water. (Other

TABLE IV.

TRIAL 1.					
11.34	A (19')	B (14')	C (9')	D (4')	Unfert.
2'	19.3	18.6	15.9	12.1	11.6
4'	30.9	29.9	26.8	21.1	20.0
TRIAL 2.					
11.47	A X	B X	Sperm X	12.5 c.c. Sp. X 12.5 c.c. Unf. X	Unfert. X
2'	14.9	14.2	9.0	13.6	14.5
4'	24.7	24.1	14.7	21.8	24.3
TRIAL 3.					
12.01	Sperm X	12.5 c.c. Sp. X 12.5 c.c. S. W.	12.5 c.c. Unf. X 12.5 c.c. S. W.	12.5 c.c. Unf. X. 12.5 c.c. Sp. X	Unfert. X
2'	7.8	4.6	8.0	14.0	15.5
4'	13.1	7.4	13.6	22.3	26.2
TRIAL 4.					
?	Sperm X	12.5 c.c. Sp. X. 12.5 c.c. S. W.	12.5 c.c. Unf. X. 12.5 c.c. S. W.	12.5 c.c. Unf. X. 12.5 c.c. Sp. X.	Unfert. X
2'	5.1	3.1	7.3	13.6	13.7
4'	8.9	5.1	12.5	21.6	23.5

experiments showed that sea water of itself has a slight augmenting effect in such cases, but for manifest reasons further dilution with distilled water would introduce a more serious error.) The results of the action of a mixture of Sperm X and Unfert. X (Col. 4) will be seen to exceed the sum of the actions of the constituents taken separately, with sea water dilution as explained (Cols. 2 and 3).

It was assumed that fertilization could not take place in the diluted sea water. No microscopic control is recorded. Other desirable variations and controls were omitted, and the experiment was performed but once at Beaufort, being left for further elaboration at Woods Hole. Unfortunately, as already explained, lack of material prevented this. The experiment must therefore be looked upon, like that of Ostwald spoken of early in this paper, as suggestive only, and the subject left open for further experimentation next season.

#### RATE OF EVOLUTION OF OXYGEN.

Study of the tables will show that in the second two minutes of any trial less oxygen, as a rule, is set free than in the first two minutes. This is particularly true of those eggs fertilized some minutes previous to the trial, and is in accordance with the usual observation on enzyme action. I have not studied the figures with a view to their conforming mathematically to any rule of chemical action. It is striking, however, that in the columns of results from the unfertilized or just fertilized eggs the production of gas for the second two minutes is often nearly or quite equal to that of the first two-minute period. Similarly the amount of gas set free in the third two minutes is proportionately greater in using unfertilized than in using fertilized eggs (see Table III). Avoiding further tables, it may be stated that in one experiment an average of five trials with eggs fertilized thirty-two minutes previously gives for two, four, and six minutes, respectively, gas productions amounting to 18.5 c.c., 28.3 c.c. and 34.2 c.c. Eggs fertilized two minutes (really the same as unfertilized) give for the same intervals 7.3 c.c., 13.2 c.c., 18.6 c.c. The relation of the two-minute gas production to the four-minute production is for fertilized eggs as 1.0 to 1.5. For the unfertilized this relation is as 1.0 to 1.8. Similarly for the two and six minute periods the ratio for fertilized eggs is 1.8; for unfertilized, 2.5. Compared in another way, the eggs fertilized two minutes (equivalent to unfertilized) produced in the first two minutes less than half as much gas as eggs fertilized thirty-two minutes produced in the same period of two minutes. In the third two minutes, however, these (unfertilized) eggs produced 5.3 c.c., while the fertilized produced 5.9 c.c., or practically the same. The proportionately greater diminution in the rate of oxygen production in the fertilized eggs in later time intervals may be due

to the lessened quantity of  $H_2O_2$  (and enzyme?) present. On the other hand, the possibility that differences of permeability lie at the basis of these results, obtained as they were with entire eggs, must not be lost sight of. It will be noted that when the eggs were burst open by distilled water there was no difference between fertilized and unfertilized eggs as to rate of evolution of gas during the first two minutes. See, for example, Table IV, Col. 5, trials 2, 3, and 4, comparing these with trial 1 and with Cols. 1 and 2, trial 2.

In the experiments it was observed that a period of twenty to thirty seconds would elapse after peroxide and eggs were mixed before there was any fall of water in the burettes, or, in other words, any visible production of gas. This time was attributed to the saturation of the water with gas. It seems, on subsequent consideration, more reasonable that a large part of it was the time it took peroxide and enzyme to come together; and quite likely careful observation would show that there is a difference between fertilized and unfertilized eggs, in the length of this latent period.

#### BEARINGS OF THE PERMEABILITY THEORY.

R. Lillie<sup>9</sup> considers that changes in permeability of the egg lie at the basis of cell division. If it can be shown that the changes in eggs following fertilization described in this article are due to changes of permeability rather than to an actual increase of catalase, it will be interesting to study their possible relation to Lillie's theory. The fact, however, that no rhythmical change in catalase could be demonstrated, corresponding to cell divisions, would apparently preclude any present belief that catalase lies in close relation to the phenomena of cleavage. That more accurate methods, — for example, the titration method of Ostwald — might demonstrate such a rhythmical change in catalase is not beyond possibility.

#### SUMMARY.

The experiments show clearly that if the *entire* eggs of *Toxopneustes* or *Arbacia* be treated with hydrogen peroxide, much more oxygen is set free by eggs which have been fertilized a few minutes than by un-

<sup>9</sup> R. LILLIE: Biological Bulletin, 1909, xvii, p. 188.

fertilized eggs. The change in catalytic power begins about three minutes after sperm is added and reaches a maximum in about twenty minutes. No further striking change in catalase content or action is demonstrable either with each succeeding cleavage or at later stages of development.

The most probable explanations of the striking increase in catalase action following fertilization are:

1. The sperm may carry in a kinase or activating body.
2. Fertilization may be followed by increased permeability or other changes by which the peroxide and enzyme come more easily together. In this case the increase in catalase would be apparent only.

A number of inconclusive experiments are recorded in the attempt to decide between the two theories. Some results such as those following the use of distilled water, freezing, heating, and the rate of evolution of oxygen seem to indicate the second theory. On the other hand, one experiment in which dead eggs and sperm were mixed, with apparent augmentation of catalase, speaks for the first theory.

THE ELIMINATION OF TOTAL NITROGEN, UREA AND AMMONIA FOLLOWING THE ADMINISTRATION OF SOME AMINOACIDS, GLYCYLGLYCIN AND GLYCYLGLYCIN ANHYDRID.

BY P. A. LEVENE AND G. M. MEYER.

[From the Rockefeller Institute for Medical Research, New York.]

THE present investigation represents a continuation of a work, the results of which were recently reported by Levene and Kober.<sup>1</sup> In that communication attention was called to the observations made by Graffenberger,<sup>2</sup> Falta,<sup>3</sup> Voigt<sup>4</sup> and others, on the behavior of various aminoacids in the organism. Levene and Kober pointed out that the rate of elimination of the nitrogen introduced into the gastrointestinal tract in the form of protein differs with the character of the protein. It was also pointed out that no attempt had been made to offer a satisfactory explanation for the difference in the resistance shown by individual proteins to the action of digestive glands and organs. On the other hand, it has become known that proteins differ one from another either by the character of the aminoacids which enter into their molecule, or by the mode of union of these acids within the molecule. It was therefore deemed necessary to precede the analysis of the factors regulating the metabolism of individual proteins by the study of the rate of catabolism of simple aminoacids on one hand and of peptids on the other.

The first communication contained a report of the results of the study of the elimination of total nitrogen, of urea and of ammonia nitrogen after administration of two aminoacids and one diketopiperazin, as com-

<sup>1</sup> LEVENE and KOBER: This journal, 1909, xxviii, p. 324.

<sup>2</sup> GRAFFENBERGER: Zeitschrift für Biologie, 1891, xxviii, p. 318.

<sup>3</sup> FALTA: Deutsche Archiv für klinische Medicin, 1904, lxxxi, p. 231; 1906, lxxxvi, p. 517.

<sup>4</sup> VOIGT: HOFMEISTER'S Beiträge, 1906, v, p. 409.

pared with the results obtained after administration of protein. In the present investigation the number of aminoacids employed was greatly enlarged, the experiment with glycylglycin anhydrid was repeated, and the result compared with that obtained after administration of the peptid. Besides, the plan of the experiment was to a certain degree modified in the present work. In the previous experiments the entire daily ration was given to the animal in one meal, in the morning. This led to a variable rate of nitrogen elimination during the following twenty-four hours. The rate was expressed in the form of a curve, the highest point being reached about six hours after the intake, and then gradually declining. The aminoacid or other substance under investigation was added to the meal. Also on such days the rate of elimination could be presented in the form of a curve. The comparison of the two curves offered, however, certain inconveniences. Furthermore, the large mass of the intake lowered the rate of absorption of the ingested material, and thus somewhat obscured the process as it would have taken place under entirely normal conditions.

For these reasons it was deemed advisable to divide the daily rations into five equal portions, and administer them at regular intervals of three hours each. In this manner there was obtained an approximately uniform nitrogen elimination during all hours of the day, and the rate of elimination on the days of the standard diet could be practically expressed in form of a straight line. The substances added to the standard diet were administered with the morning meal. On such days the rate of elimination was variable during the twenty-four hours following the added intake, and could be expressed in the form of a curve, easily comparable with the straight line of the normal intake.

#### EXPERIMENTAL PART.

**Methods of analysis.**—The methods of analysis employed in these investigations, with one exception, were the same as those described in the previous communication. For the estimation of urea, use was made of the Benedict-Gephart method.<sup>5</sup> The urine was obtained by catheterization at three-hour intervals, and the quantity obtained in

<sup>5</sup> BENEDICT and GEPHART: *Journal of the American Chemical Society*, 1908, xxx, p. 1760.

this manner added to any urine voided by the animal in the cage between catheterizations.

**Period of standard diet.** — Three dogs were used in course of this investigation. They will be referred to as dogs A, B and C. The standard diet of dog A varied somewhat in the course of the experiments. It consisted either of:

		gm. N.	calories.
I.	Plasmon . . . . . 17.5 gm. containing	1.99	71.2
	Cracker meal . . . 100.0 gm. "	1.50	440
	Lard . . . . . 25.0 gm. "	...	232
	Total intake . . . . .	3.49	714
II.	Plasmon . . . . . 25.0 gm. containing	2.85	102.5
	Cracker meal . . . 75.0 gm. "	1.12	307.5
	Lard . . . . . 25.0 gm. "	...	232.0
	Total intake . . . . .	3.97	642.0

The diet of dog B consisted of:

Plasmon . . . . . 12.5 gm. containing	14.2	51.2
Cracker meal . . . 60.0 gm. "	0.90	246.0
Lard . . . . . 25.0 gm. "	...	232.0
Total intake . . . . .	2.32	529.2

The diet of dog C consisted of:

Plasmon . . . . . 16.5 gm. containing	1.880	67.8
Cracker meal . . . 75.0 gm. "	1.125	307.0
Lard . . . . . 25.0 gm. "	...	232.0
Total intake . . . . .	3.00	606.8

Tables I, II and III contain the rate of elimination of total nitrogen, of urea and ammonia nitrogen by these two animals on the respective diets. The rate of elimination during the twelve hours beginning with the second three-hour period and ending with the fourth period in which the most marked changes after additional feeding are to be expected, present only very moderate fluctuations. In some other animals used for other experiments the fluctuations were still more insignificant. The protein absorption from the intestinal tract was normal, and the nitrogen distribution in the urine in harmony with previous experience.



*Increased plasmon experiment.*—This experiment was performed on dog B. On the day of the experiment 1.79 gm. of nitrogen in the form of plasmon were added to the standard diet. The rates of elimination through the urine are recorded in Table IV.

	Total N.	Urea N.
The total elimination on the day of experiment	2.989 gm.	2.684 gm.
The total elimination on the day of standard diet	2.077 gm.	1.792 gm.
	0.912 gm.	0.892 gm.

Comparing the results of this experiment with those reported in the previous publication,<sup>6</sup> one notes that the rate of elimination is higher and that of retention lower when the daily ration is given in fractional doses. Thus, there was a retention after the first twenty-four hours following the intake of the additional plasmon of only 43.46 per cent of nitrogen in the present experiment and of 74 per cent in the older experiment. The excessive nitrogen was eliminated also in this experiment exclusively in the form of urea.

*Alanin experiment.*—The experiments with this aminoacid were performed on dog B. Observations were made with the optically active, naturally occurring l-alanin and with the inactive (d-l) acid. It has been known from previous observations that after the administration of the optical inactive (d-l) form of aminoacids the antipode to the naturally occurring substance reappears in the urine unchanged.<sup>7</sup> However, it has not been known whether or not the d-alanin is removed completely. The observation recorded in the previous publication, that the nitrogen of nitrogenous substances catabolized in the organism of the dog is removed exclusively in the form of urea, furnishes a method for a quantitative estimation of the part which is catabolized as compared with that which is removed without having suffered deterioration. *A priori*, it does not seem improbable that even optical antipodes of the same acid should be utilized by the organism, and for the following reasons. Observations are recorded that on digestion of protein the d-l form of aminoacids is formed.<sup>8</sup> Since only optically active substances enter into the structure of protein, it is natural to believe that the racemization took place in the process of digestion. On the other hand,

<sup>6</sup> LEVENE and KOBER: *Loc. cit.*, p. 323.

<sup>7</sup> KUTCHER: *Zeitschrift für physiologische Chemie*, 1898, xxv, p. 195.

<sup>8</sup> LEVENE: Ueber die Verdauung der Gelatine, *ibid.*

racemization consists in the transformation of an optically active substance into its optical antipode. From this it would follow that the organism is in possession of a mechanism by which it can utilize the optical antipodes to the naturally occurring aminoacids. The results of the present experiments indicate that after the administration to a dog of d-l forms of aminoacids only a part of the optical antipode to the natural form is removed unchanged.

The results of the experiments with l-alanin are recorded in Table V. 13 gm. of alanin containing 2 gm. of nitrogen were added to the standard diet containing 3.97 gm. of nitrogen. The output was the following:

	Total N.	Urea N.
On the day of the l-alanin feeding . . . . .	5.568 gm.	5.182 gm.
On the day of the standard diet . . . . .	<u>3.598 gm.</u>	<u>3.208 gm.</u>
Removed in excess over the day of the standard diet . . . . .	1.973 gm.	1.974 gm.

Thus all the nitrogen of the alanin was removed within the first twenty-four hours after its intake, and of this nearly 90 per cent was removed within the first nine hours. This rate of elimination is much higher than the one observed under the previous mode of experimentation. Also here the entire excessive nitrogen was removed in the form of urea.

The results of the experiment with l-alanin are recorded in Table VI; 20 gm. of alanin containing 3.15 gm. were added to the second standard diet of dog A. The output was the following:

	Total N.	Urea N.
On the day of the experiment . . . . .	6.755 gm.	5.860 gm.
On the day of the standard diet . . . . .	<u>3.595 gm.</u>	<u>3.203 gm.</u>
In excess over the standard diet . . . . .	3.160 gm.	2.657 gm.

The general character of nitrogen elimination was similar to the one after feeding of l-alanin. All the nitrogen of the additional intake was removed within the first twenty-four hours and the larger part of it (nearly 76 per cent) within the first nine hours after the intake.

Of the excessive nitrogen contained in the urine on the day of the experiment only 84 per cent was in the form of urea. Taking into consideration that the ingested i-alanin contained 50 per cent of l-alanin which is completely converted into urea, one reaches the conclusion that of the remaining 50 per cent only 34 per cent was converted into urea

and 16 per cent was removed unchanged, thus showing that of the optical antipode to the natural alanin only 32 per cent was eliminated without having undergone any change.

*Leucin experiment.*— Also with this aminoacid an attempt was made to compare the behavior of the two optical forms, the naturally occurring l-leucin and the d-l leucin. It was found impossible, however, to obtain a successful experiment with the latter form, since dogs invariably vomited after administration of i-leucin. Therefore the experiments were performed only with l-leucin. Only two experiments with this aminoacid are recorded by previous observers, namely, by Abderhalden and Samuely.<sup>9</sup> The results of their experiments are not very convincing, though the conclusions the authors base on them are correct. In our experiments on dog B, 14.4 gm. of leucin containing 1.54 gm. of nitrogen were added to the standard diet. The results are recorded in Table VII. The output was the following:

	Total N.	Urea N.
On the day of the experiment . . . . .	2.899 gm.	2.614 gm.
On the day of the standard diet . . . . .	<u>2.077 gm.</u>	<u>1.792 gm.</u>
In excess over the standard diet . . . . .	0.822 gm.	0.822 gm.
On the day following the experiment . . . . .	2.635 gm.	2.346 gm.
On the day of the standard diet . . . . .	<u>2.077 gm.</u>	<u>1.992 gm.</u>
In excess over the standard diet . . . . .	0.558 gm.	0.554 gm.

Comparing the results of these experiments with those when the animals were fed on the lower aminoacids, one is struck by the low rate of nitrogen elimination. Only 53.37 per cent of the excessive intake was removed during the first twenty-four hours, 36.23 per cent of the intake was eliminated in the following twenty-four hours. Thus it may appear as if the administration of this aminoacid may be followed by a lasting nitrogen retention. In order to test the possibility of nitrogen retention after administration of l-leucin, this aminoacid was added continually for five days in quantities containing 1 gm. of nitrogen per day. The results are recorded in the following table, which demonstrates that there was no nitrogen retention following the five days of

<sup>9</sup> ABDERHALDEN and SAMUELY: *Zeitschrift für physiologische Chemie*, 1906, xlvii, p. 346.

feeding with leucin in addition to the standard diet. As will be seen from results to be published in a subsequent paper, this low rate of nitrogen eliminated may be explained by the slow transportation of leucin from the stomach into the intestinal tract, and by the low rate of absorption of the acid through the gastric wall. Comparing the results recorded in Table VII with those obtained on feeding with the lower aminoacids, one notes the slow and continuous rise of the nitrogen output on the day of the experiment as compared with the normal days.

The nitrogen recovered in excess over that of the normal days is composed exclusively of urea also after feeding of l-leucin.

## ADMINISTRATION OF L-LEUCIN.

Day.	Total nitrogen in grams.		Day.	Total nitrogen in grams.	
	Urine.	Feces.		Urine.	Feces.
1	2.68	....	4	3.51	0.294
2	2.94	0.520	5	2.41	0.293
3	3.21	0.304	6	2.42	0.286
Total . . . . .				17.17	1.697
Intake . . . . .		Food 13.98			
		l-Leucin 5.00		18.98 gm. N.	
Total . . . . .		Urine 17.17			
Output . . . . .		Feces 1.70		18.87 " "	
Total . . . . .				+0.11 gm. N.	
Balance . . . . .					

*Phenylalanin experiment.* — On the day of the experiment on dog A, 24 gm. of l-d phenylalanin were added to the second standard diet. The output was the following:

	Total N.	Urea N.
On the day of the experiment . . . . .	5.265 gm.	4.302 gm.
On the day of the standard diet . . . . .	3.595 gm.	<u>3.203 gm.</u>
In excess over the standard diet . . . . .	1.670 gm.	1.099 gm.

The details of the experiment are recorded in Table VIII. The analysis of this table reveals the fact that after administration of this amino-acid the rate of the elimination of the excess nitrogen followed the course of nitrogen elimination after leucin feeding. As compared with the days when the lower aminoacids were added to the standard diet, the nitrogen output presented a slower and a more continuous rise.

Of the excessive nitrogen removed by the urine only 65.8 per cent were in the form of urea. Accepting that the nitrogen of the natural l-phenylalanin is converted completely into urea, one is led to the conclusion that of the optical antipode only 31.6 per cent is converted into urea, the remaining portion is removed unaltered.

*Asparaginic acid experiment.*— In a previous publication Levene and Kober<sup>10</sup> noted that the rate of absorption of asparagin from the gastrointestinal tract and the rate of the nitrogen elimination following its ingestion appeared of lower magnitude, compared with that following the administration of glycin. It is very probable, particularly on the ground of the statements of Osborne,<sup>11</sup> that substances of the chemical nature of asparagin (acid amids) are present in the protein molecule. Through the action of mineral acids and enzymes the amido group of these substances is removed with comparatively little resistance, and the acid amid is transformed into the original acid. On the other hand, the original acid-asparaginic acid in this instance represents a constant component of the protein molecule. In view of all these considerations it was deemed of particular interest to compare the behavior in the organism of asparaginic acid with that of asparagin. The experiment was performed on dog A. 19.0 gm. of d-l asparaginic acid containing 2.0 gm. of nitrogen were added to the first standard diet. The output was the following:

	Total N.	Urea N.
On the day of the experiment . . . . .	5.185 gm.	4.548 gm.
On the day of the standard diet . . . . .	<u>3.380 gm.</u>	<u>3.029 gm.</u>
In excess over the standard diet . . . . .	1.805 gm.	1.519 gm.

The analysis of Table IX reveals a rate of nitrogen elimination not unlike the one following the administration of the lower aminoacids.

<sup>10</sup> LEVENE and KOBER: This journal, 1909, xxiii, p. 332.

<sup>11</sup> THOMAS OSBORNE, C. S. LEAVENWORTH and C. A. BRAUTLECHT: This journal, 1908, xxiii, p. 180.

During the first twelve hours following the intake 86.66 per cent of the excessive output was removed. There was no appreciable retention of nitrogen after the first twenty-four hours.

Of the total excessive output 84 per cent was removed in the form of urea. On the basis that all the nitrogen of the l-asparaginic acid was removed in the form of urea, the conclusion may be reached that of the optical antipode 31.6 per cent was removed unaltered. The same value was found for d-alanin.

*Arginin experiment.*—The experiment was performed on dog B. The arginin employed in the experiment was obtained by the tryptic digestion of edestine. 3.55 gm. of arginin containing 1.142 gm. of nitrogen were added to the first meal. The output of nitrogen was as follows:

	Total N.	Urea N.
On the day of the experiment . . . . .	3.017 gm.	2.706 gm.
On the day of the standard diet . . . . .	<u>2.077 gm.</u>	<u>1.792 gm.</u>
In excess over the standard diet . . . . .	0.940 gm.	0.914 gm.

The analysis of Table X reveals that the rate of elimination of the excessive nitrogen after administration of arginin as compared with the rate following the administration of the lower aminoacids is lower, and the elimination more protracted. This seems rather significant since arginin is a derivative of guanidine and possesses a high solubility.

Only 97 per cent of the excessive nitrogen was removed in the form of urea. This was possibly caused by the fact that the arginin was to some extent racemized.

*Glycylglycin and glycyglycin anhydrid experiments.*—Feeding experiments with monopeptides and their anhydrids had been performed by Abderhalden and Rona.<sup>12</sup> The authors did not record any difference in the behavior of the anhydrids as compared with peptids. On the other hand, in an experiment performed by Levene and Kober<sup>13</sup> the observation was made that the anhydrid was removed through the urine apparently without having suffered any alteration. The experiment had been performed on a dog in a state of inanition and could not be repeated at that time. It was, therefore, concluded to repeat the

<sup>12</sup> ABDERHALDEN and RONA: *Zeitschrift für physiologische Chemie*, 1905, xlvi, p. 176.

<sup>13</sup> LEVENE and KOBER: *Loc. cit.*

experiment and to compare the results with those obtained on feeding the peptid.

The experiments were performed on dog B. On the day of the peptid experiment the dog received 7 gm. of glycyglycin containing 1.48 gm. of nitrogen. The nitrogen output was the following:

	Total N.	Urea N.
On the day of experiment . . . . .	3.676 gm.	3.348 gm.
On the day of the standard diet . . . . .	<u>2.077 gm.</u>	<u>1.792 gm.</u>
In excess over standard diet . . . . .	1.599 gm.	1.556 gm.

The rate of nitrogen elimination is recorded on Table XI, and shows great similarity with that following glycin administration. All the excessive nitrogen is removed in the form of urea.

Two experiments were performed with the anhydrid. In each experiment 6 gm. of the substance containing 1.47 gm. of nitrogen were added to the standard diet. The nitrogen output was the following:

	Total N.	Urea N.
First exp. on the day of the experiment . . . . .	3.353 gm.	1.747 gm.
First exp. on the day of the standard diet . . . . .	<u>2.077 gm.</u>	<u>1.792 gm.</u>
In excess over the standard diet . . . . .	1.276 gm.	0.045 gm.
Second exp. on the day of the experiment . . . . .	3.480 gm.	1.771 gm.
Second exp. on the day of the standard diet . . . . .	<u>2.077 gm.</u>	<u>1.792 gm.</u>
In excess over the standard diet . . . . .	1.403 gm.	0.021 gm.

The rate of nitrogen elimination in these two experiments is recorded in Tables XII and XIII, and shows a more rapid increase than the one following the administration of glycin or of glycyglycin. Of the total excessive nitrogen in one experiment 87.77 per cent and in the other 83.86 per cent is removed within the first nine hours after the intake. In neither of the two experiments was any transformation observed of the excess nitrogen into urea. Since after administration of the peptid such transformation does occur, one is justified to conclude that the anhydrid is removed through the urine unchanged.

*Gelatine experiment.* — It seemed possible to base on the property of glycyglycin anhydrid — to pass unaltered through the organism of the dog — a method for ascertaining whether or not the anhydrids of the peptids, or the diketopiperazines enter into the composition of the

protein molecule. *A priori* this seems possible. Existing experimental evidence is, however, not conclusive. With certainty a diketopiperazin was obtained on protein cleavage only once, namely, by Levene and Beatty<sup>14</sup> on tryptic digestion of gelatine.

However, the digestion in that instance was allowed to continue many months, and thus the possibility is not excluded that the transformation of the peptid was a secondary process. On the basis of the experiment with glycyglycin anhydrid one is led to expect that when proteins containing diketopiperazins in their molecule are added to a standard diet of a dog, the excessive nitrogen thus introduced in the organism will only in part be removed in the form of urea.

On the day of experiment the dog C received 14 gm. of gelatine containing 2.00 gm. of nitrogen in addition to the standard diet. The nitrogen output was as follows:

	Total N.	Urea N.
On the day of experiment . . . . .	4.315 gm.	3.960 gm.
On the day of the standard diet . . . . .	2.514 gm.	2.158 gm.
	<hr/> 1.801 gm.	<hr/> 1.802 gm.

It is evident from the figures that all of the excessive nitrogen administered as gelatine is eliminated in the form of urea. Thus, this experiment leads to the conclusion that either diketopiperazins do not enter into the composition of the protein molecule, or that the anhydrids of peptids within the protein molecule offer less resistance than when in a free state. The rate of nitrogen elimination is recorded in Table XV.

<sup>14</sup> LEVENE and BEATTY: Berichte der deutschen chemischen Gesellschaft, 1906, xxxix, p. 2091.



TABLES I-III.

TABLE I. STANDARD DIET A, DOG I.

Periods.	Total nitrogen in grams.	Urea nitrogen.		Ammonia nitrogen.		Undetermined nitrogen.	
		Grams.	Per cent of total nitrogen.	Grams.	Per cent of total nitrogen.	Grams.	Per cent of total nitrogen.
9-12	0.266	0.235	88.5	0.003	1.1	0.028	10.5
12-3	0.515	0.468	90.1	0.006	1.1	0.041	8.0
3-6	0.595	0.526	88.5	0.018	3.0	0.051	8.5
6-9	0.672	0.591	88.0	0.019	2.8	0.062	9.2
9-12	0.455	0.401	89.2	0.015	3.6	0.039	8.5
12-9	1.092	0.982	89.9	0.068	6.2	0.042	3.9

TABLE II. STANDARD DIET B, DOG I.

9-12	0.427	0.379	88.9	0.017	3.9	0.031	7.0
12-3	0.555	0.511	92.1	0.021	3.8	0.023	4.2
3-6	0.545	0.494	90.6	0.018	3.3	0.031	5.7
6-9	0.512	0.461	89.8	0.016	3.1	0.035	6.8
9-12	0.436	0.395	90.4	0.018	4.1	0.023	5.3
12-9	0.904	0.789	87.0	0.073	8.1	0.042	4.7

TABLE III. STANDARD DIET, DOG II.

9-12	0.135	0.115	85.2	0.006	4.4	0.014	10.3
12-3	0.434	0.368	84.8	0.026	6.0	0.040	9.2
3-6	0.310	0.265	85.2	0.025	8.0	0.020	6.4
6-9	0.344	0.300	88.4	0.028	8.2	0.016	4.6
9-12	0.294	0.255	86.8	0.025	8.5	0.014	4.7
12-9	0.560	0.492	87.6	0.039	6.9	0.029	5.2

TABLES IV-VI.

TABLE IV. STANDARD DIET, DOC C.							
Periods.	Total nitrogen in grams.	Urea nitrogen.		Ammonia nitrogen.		Undetermined nitrogen.	
		Grams.	Per cent of total nitrogen.	Grams.	Per cent of total nitrogen.	Grams.	Per cent of total nitrogen.
9-12	0.212	0.172	81.2	0.008	3.7	0.032	15.1
12-3	0.397	0.356	89.7	0.011	2.8	0.030	7.5
3-6	0.385	0.337	87.5	0.013	3.9	0.035	9.1
6-9	0.403	0.343	85.1	0.016	3.8	0.044	11.0
9-12	0.362	0.297	81.4	0.010	3.4	0.053	15.2
12-9	0.759	0.653	86.3	0.037	4.9	0.069	8.7

TABLE V. STANDARD DIET AND PLASMON.							
9-12	0.245	0.223	91.1	0.004	1.6	0.018	7.3
12-3	0.532	0.483	90.8	0.014	2.6	0.035	6.6
3-6	0.546	0.490	89.8	0.014	2.6	0.042	7.6
6-9	0.504	0.449	89.1	0.031	6.1	0.024	4.8
9-12	0.308	0.283	91.8	0.011	3.6	0.014	4.6
12-9	0.854	0.756	88.5	0.056	6.5	0.042	5.0

TABLE VI. STANDARD DIET AND L-ALANIN.							
9-12	0.761	0.701	92.1	0.005	0.6	0.055	7.2
12-3	1.092	0.995	91.1	0.017	1.5	0.080	7.3
3-6	1.277	1.188	93.0	0.029	2.3	0.060	4.7
6-9	0.702	0.640	91.2	0.032	4.5	0.030	4.3
9-12	0.616	0.599	97.2	0.008	1.3	0.009	1.5
12-9	1.120	1.059	94.6	0.041	3.6	0.020	1.8

<sup>1</sup> These figures show balance with standard diet.

TABLES VII-IX.

TABLE VII. STANDARD DIET AND L-ALANIN.

Periods.	Total nitrogen in grams.	Urea nitrogen.		Ammonia nitrogen.		Undetermined nitrogen.	
		Grams.	Per cent of total nitrogen.	Grams.	Per cent of total nitrogen.	Grams.	Per cent of total nitrogen.
9-12	0.980	0.856	87.5	0.009	0.9	0.115	11.5
	+0.714						
12-3	1.557	1.268	81.5	0.022	1.4	0.267	17.1
	+1.042						
3-6	1.224	1.116	91.1	0.036	2.9	0.073	5.9
	+0.630						
6-9	0.885	0.774	87.5	0.031	3.5	0.085	9.0
	+0.213						
9-12	0.899	0.805	90.5	0.040	4.5	0.045	5.0
	+0.435						
12-9	1.218	1.041	85.5	0.079	6.5	0.098	8.0
	+0.126						

TABLE VIII. STANDARD DIET AND L-LEUCIN.

9-12	0.168	0.150	89.2	0.010	5.9	0.008	4.8
	+0.033						
12-3	0.406	0.368	90.6	0.026	6.4	0.012	3.0
	-0.028						
3-6	0.462	0.417	90.3	0.028	6.1	0.017	5.7
	+0.152						
6-9	0.560	0.516	92.2	0.020	3.6	0.024	4.3
	+0.216						
9-12	0.371	0.337	90.8	0.010	2.7	0.024	6.5
	+0.077						
12-9	0.932	0.826	88.6	0.062	6.7	0.044	4.5
	+0.372						

TABLE IX. STANDARD DIET AND L-PHENYLALANIN.

9-12	0.441	0.329	74.8	0.021	4.8	0.091	20.6
	+0.175						
12-3	0.586	0.463	79.1	0.025	4.2	0.098	17.0
	+0.071						
3-6	0.640	0.518	80.9	0.025	3.9	0.097	15.1
	+0.045						
6-9	0.882	0.710	80.6	0.039	4.4	0.033	3.7
	+0.110						
9-12	0.700	0.602	86.1	0.035	5.0	0.063	9.0
	+0.245						
12-9	2.016	1.680	84.1	0.140	6.9	0.196	9.7
	+0.924						

TABLES X-XII.

TABLE X. STANDARD DIET AND L-ASPARAGINIC ACID.							
Periods.	Total nitrogen in grams.	Urea nitrogen.		Ammonia nitrogen.		Undetermined nitrogen.	
		Grams.	Per cent of total nitrogen.	Grams.	Per cent of total nitrogen.	Grams.	Per cent of total nitrogen.
9-12	0.459	0.380	82.8	0.033	7.2	0.046	10.0
	+0.032						
12-3	1.052	0.922	87.6	0.062	5.9	0.068	6.5
	+0.497						
3-6	1.070	0.837	78.2	0.045	4.2	0.188	17.5
	+0.525						
6-9	0.868	0.810	93.4	0.030	3.5	0.028	3.2
	+0.356						
9-12	0.644	0.608	94.5	0.022	3.4	0.014	2.2
	+0.208						
12-9	1.092	0.991	90.7	0.045	4.1	0.056	5.1
	+0.188						

TABLE XI. STANDARD DIET AND ARGININ.							
9-12	0.322	0.256	79.6	0.003	0.9	0.063	19.5
	+0.187						
12-3	0.644	0.595	92.4	0.017	2.6	0.032	4.9
	+0.210						
3-6	0.476	0.445	93.4	0.017	3.6	0.014	3.0
	+0.166						
6-9	0.462	0.431	93.2	0.017	3.7	0.014	3.1
	+0.118						
9-12	0.357	0.312	87.4	0.024	6.7	0.021	5.9
	+0.063						
12-9	0.756	0.667	88.2	0.068	9.0	0.021	2.8
	+0.196						

TABLE XII. STANDARD DIET AND GLYCYLGLYCIN.							
9-12	0.364	0.345	94.8	0.011	3.0	0.008	2.2
	+0.229						
12-3	1.036	0.954	92.0	0.028	2.7	0.054	5.3
	+0.602						
3-6	0.580	0.534	92.1	0.020	3.4	0.026	4.5
	+0.270						
6-9	0.490	0.446	91.0	0.018	3.7	0.024	5.3
	+0.146						
9-12	0.434	0.395	91.0	0.004	8.9	0.035	8.1
	+0.140						
12-9	0.772	0.674	87.4	0.062	8.0	0.036	4.6
	+0.212						

TABLES XIII-XV.

TABLE XIII. STANDARD DIET AND GLYCYLGLYCIN ANHYDRID.

Periods.	Total nitrogen in grams.	Urea nitrogen.		Ammonia nitrogen.		Undetermined nitrogen.	
		Grams.	Per cent of total nitrogen.	Grams.	Per cent of total nitrogen.	Grams.	Per cent of total nitrogen.
9-12	0.507	0.158	31.1	0.006	1.2	0.343	67.7
12-3	0.960	0.282	29.4	0.028	2.8	0.650	67.8
3-6	0.532	0.294	55.3	0.012	2.3	0.226	42.5
6-9	0.442	0.259	58.8	0.021	4.7	0.162	36.5
9-12	0.282	0.220	78.1	0.016	5.7	0.078	19.2
12-9	0.630	0.534	84.7	0.042	6.7	0.054	8.6

TABLE XIV. STANDARD DIET AND GLYCYLGLYCIN ANHYDRID.

9-12	0.654	0.209	31.9	0.009	1.4	0.436	66.7
12-3	0.875	0.254	29.0	0.014	1.6	0.607	69.4
3-6	0.524	0.250	47.7	0.030	5.7	0.244	46.6
6-9	0.405	0.287	70.8	0.014	3.4	0.104	25.7
9-12	0.348	0.253	72.7	0.015	4.3	0.080	23.0
12-9	0.674	0.518	76.9	0.069	10.2	0.087	12.9

TABLE XV. STANDARD DIET AND GELATINE.

9-12	0.456	0.407	89.2	0.015	3.3	0.034	7.5
12-3	0.785	0.732	93.3	0.025	3.2	0.028	3.5
3-6	0.787	0.731	92.8	0.023	2.9	0.033	4.2
6-9	0.795	0.733	92.2	0.026	3.3	0.036	4.5
9-12	0.492	0.455	92.6	0.018	3.7	0.019	3.7
12-9	1.000	0.902	90.2	0.053	5.3	0.045	4.5

TABLES I-XV.  
TOTALS FOR TWENTY-FOUR HOURS.

No. of table.	Diet.	Total nitrogen in grams.	Urea nitrogen.		Ammonia nitrogen.		Undetermined nitrogen.	
			Grams.	Per cent of total nitrogen.	Grams.	Per cent of total nitrogen.	Grams.	Per cent of total nitrogen.
I	Standard I, Dog A (I A) . .	3.595	3.203	89.3	0.129	3.6	0.263	7.3
II	Standard II, Dog A (II A) .	3.380	3.029	89.6	0.163	4.8	0.185	5.5
III	Standard Dog B (B) . . . .	2.077	1.792	86.5	0.149	7.1	0.133	6.4
IV	Standard Dog C (C) . . . .	2.514	2.158	85.8	0.097	3.7	0.263	9.9
V	B and Plasmon . . . . .	2.989	2.684	89.6	0.134	4.6	0.171	5.7
VI	I A and l-Alanin . . . . .	5.568	5.182	93.0	0.132	2.4	0.254	4.6
VII	I A and i-Alanin . . . . .	6.755	5.860	86.8	0.227	3.4	0.668	9.9
VIII	B and l-Leucin . . . . .	2.899	2.614	90.2	0.154	5.4	0.131	4.5
IX	I A and i-Phenylalanin . .	5.265	4.302	81.7	0.285	5.4	0.678	12.8
X	II A and i-Asparaginic-acid .	5.185	4.548	88.6	0.237	4.5	0.400	7.7
XI	B and Arginin . . . . .	3.017	2.706	89.8	0.146	4.8	0.165	5.4
XII	B and Glycylglycin . . . .	3.676	3.348	91.1	0.143	3.9	0.185	5.0
XIII	B and Glycylglycin anhydrid	3.353	1.747	52.1	0.125	3.7	1.481	44.2
XIV	B and Glycylglycin anhydrid	3.480	1.771	50.8	0.151	4.3	1.558	44.8
XV	C and Gelatine . . . . .	4.315	3.960	91.8	0.160	3.7	0.197	4.5

## THE INFLUENCE OF THE REMOVAL OF SEGMENTS OF THE GASTROINTESTINAL TRACT ON THE CHARACTER OF PROTEIN METABOLISM.

By ISAAC LEVIN, D. D. MANSON, AND P. A. LEVENE.

[From the Research Division of the Montefiore Hospital, New York.]

IT is the function of the gastrointestinal tract to supply the cells and tissues of the higher animals with material which they require for maintenance of life, for their repair and regeneration, and for the performance of the part which the organism as a whole requires from the individual organs. This function is as complex as it is important. It consists of numerous phases. These are co-ordinated in such a manner that the common foodstuffs are changed in their physical and chemical properties in a varying degree so as to furnish substances some more suited for the purpose of tissue regeneration, others to serve as source of animal heat. Thus the various sections of the gastrointestinal tract are supplied with glands secreting enzymes, each capable of accomplishing only a certain phase in the transformation of the foodstuffs. The epithelial wall of the various sections is endowed with a selective permeability, so that both digestion and absorption may be graded and regulated.

The present knowledge of the exact function of every individual segment of the gastrointestinal tract is imperfect, though many workers have been engaged in the investigation of the problems of digestion. Most valuable are the contributions of E. Zunz and his collaborators, of Tobler, of Abderhalden and his co-workers, of London and associates. These very important investigations were aimed principally to unravel the mystery of the process of digestion. The methods employed by these investigators were not capable of furnishing information regarding the significance of the different segments as organs of assimilation. In fact, even regarding the process of digestion, the knowledge supplied by their studies is incomplete. They are all based on the chemical analysis

of the contents of the different segments of the digestive tract, at varying intervals after food administration. The results obtained by these investigations will be discussed in detail later. Here it will suffice to call attention to the fact that the nature of the substances which were absorbed through the wall of the digestive tract remained undiscovered by the methods employed in the previous investigations. It is natural that in the analysis of a process so complex as that of assimilation, in which many glands and organs co-operate in the most intricate harmony and purposefulness, no one single method can be expected to furnish a conclusive and complete explanation of the character of the process. It is necessary to co-ordinate the results obtained by every possible method of investigation, and on the basis of this co-ordinate information to formulate a conception of the process in its entirety.

The present investigation is concerned only with the process of protein assimilation. Its aim is to establish the nature of the substances which have passed the wall of the digestive tract and thus escaped the observation of previous workers. The method employed for this work was the study of the progress of nitrogenous metabolism on animals deprived of various segments of their digestive system.

The following communication contains the results of the first of a series of investigations in that direction.

## I. ON THE INFLUENCE OF GASTROENTEROSTOMY ON THE PROGRESS OF NITROGENOUS METABOLISM.

Until very recently physiologists attributed to the stomach a very insignificant part in the process of protein assimilation. In text-books which appeared not later than two to three years ago, the statement is still found that the rôle of the stomach is to serve as reservoir for the foodstuff, which eventually and gradually needs to be transported to the intestinal tract. The general view was that the actual digestion and absorption began only in the intestinal tract, and that in the gastric cavity the protein of the food suffered only a change in its physical properties, a change from the coagulable into the uncoagulable form, from the insoluble to the soluble. This view was based principally on the observations made on men and on animals after partial or complete gastrectomy. Men and animals after such an operation continued their normal existence, suffering apparently no discomfort.



However, the logic of this argument is not unassailable. The organism possesses various mechanisms by the aid of which it adapts itself to abnormal or unusual conditions. By raising the tax on the intestinal glands the organism can cover the lack of gastric function. The factors of safety, so ably pointed out by Meltzer, may come to the front also on this occasion. From this, however, does not necessarily follow that also in health the stomach takes no part in the actual process of protein digestion and assimilation. On the contrary, the investigations of the last few years have revealed the fact that in the gastric cavity proteins undergo a very marked degree of dissolution. Some isolated observations revealing this condition were made by older workers at a time, however, when the methods of analysis of the products of proteolysis were very imperfect. Thus Schmidt-Muhlheim<sup>1</sup> noted that beef is peptonized in the stomach. After administration of 200 gm. of beef the peptonization was completed in twelve hours. The method employed by the author was the following. Dogs were starved for a definite period, and a meal containing a known quantity of protein was given to them. At varying intervals some of them were killed, their stomachs were removed, and the gastric contents analyzed. The same method was employed also by other workers, Ellenberger and V. Hofmeister,<sup>2</sup> and A. L. Gillespie,<sup>3</sup> who came to similar conclusions. The most careful studies by the use of this method were those of E. Zunz and his co-workers.<sup>4</sup>

Through these investigations it became known that incoagulable protein derivatives of the stomach contents consisted principally of proteoses, and in a smaller proportion of pepton and biuret free substances. Very important were also the observations of Tedeschi and of E. Zunz<sup>5</sup>

<sup>1</sup> SCHMIDT-MULHEIM: *Archiv für Physiologie*, 1879, pp. 39-58.

<sup>2</sup> ELLENBERGER and V. HOFMEISTER: *Archiv für Physiologie*, 1890, pp. 280-298.

<sup>3</sup> A. L. GILLESPIE: *Journal of anatomy and physiology*, 1893, xxvii, pp. 195-223; *Proceedings of the Royal Society*, 1897, lxii, pp. 4-11.

<sup>4</sup> E. ZUNZ: *Beiträge zur chemischen Physiologie und Pathologie*, 1902, iii, pp. 339-364; *Annales de la Société royale de sciences médicales et naturelles de Bruxelles*, 1904, xiii; *Archives internationales de pharmacologie et de thérapie*, 1905, xv, pp. 203-222; *Mémoires couronnées et autorisées. Mémoires publiés par l'Académie Royale de Médecine Belgique*, xix; E. ZUNZ and MAYER LEOPOLD: *Ibid.*, 1904, xviii, fasc. 9.

<sup>5</sup> TEDESCHI: *Il policlinico*, 1904, xi, p. 441; E. ZUNZ: *Archives internationales de pharmacologie et de thérapie*, 1905, xv, pp. 203-222.

on the formation of plastein in the gastric cavity after administration of proteoses. Thus, according to these writers, there is a change of the more soluble derivatives into comparatively insoluble ones. The observations of E. Zunz were corroborated by Abderhalden.<sup>6</sup>

The polyistula method has also been employed for the study of the character of proteolysis in the gastric cavity. In recent years this method was employed by Tobler,<sup>7</sup> by London and Sulima,<sup>8</sup> London and Polowjowa,<sup>9</sup> by Abderhalden, Kautzsch, and London,<sup>10</sup> by Abderhalden, Baumann, and London,<sup>11</sup> by Körösy and London,<sup>12</sup> and by Abderhalden, London, and Voegtlin,<sup>13</sup> and also by Lang.<sup>14</sup> These writers came to the conclusion that protein undergoes a considerable degree of proteolysis in the stomach, and that the proteoses are the principal products of gastric digestion. On the basis of this, London is inclined to attribute a very secondary place to the part played by the stomach in the general process of digestion. Thus, in the article on gastric digestion, written in 1908 for Oppenheimer's "Handbuch der Biochemie," the following statement is found: "Die Hauptarbeit des Magens besteht nur darin, den grössten Teil (80-85 per cent) der genossenen Proteine in löslichen Zustand (mit einem Albumosengehalt von ca. 60 per cent) zu bringen, um sie den Fermenten des Dünndarmes zugänglicher zu machen." He further writes: "Resorption von Eiweissabfallprodukten findet im Magen nicht statt."<sup>15</sup> On this point, however, there exists no harmony in the views of individual writers, since in Cohnheim's "Physiologie der Verdauung und Ernährung," published in 1908 (p. 214), the statement is made: "Auch die Resorption der Eiweisskörper im Magen ist bedeutender als man gemeinhin angenommen hatte; denn bis zu einem Drittel des Eiweissstickstoffes kann im Magen verschwinden."

Thus even the modern writers attribute to the stomach a part which is at the best auxiliary to that of the intestinal tract. Never has there

<sup>6</sup> ABDERHALDEN: *Zeitschrift für physiologische Chemie*, 1905, lxiv, pp. 17-52.

<sup>7</sup> TOBLER: *Zeitschrift für physiologische Chemie*, 1905, lv, pp. 185-215.

<sup>8</sup> LONDON and SULIMA: *Ibid.*, 1905, xlvi, p. 205.

<sup>9</sup> LONDON and POLOWJOWA: *Ibid.*, 1907, liii, p. 1403, and 1908, lviii, p. 113.

<sup>10</sup> ABDERHALDEN, KAUTZSCH, and LONDON: *Ibid.*, 1906, xlvi, p. 549.

<sup>11</sup> ABDERHALDEN, BAUMANN, and LONDON: *Ibid.*, 1907, li, p. 383.

<sup>12</sup> KÖRÖSY and LONDON: *Ibid.*, 1907, liii, p. 147.

<sup>13</sup> ABDERHALDEN, LONDON, and VOEGTLIN: *Ibid.*, 1907, liii, p. 334.

<sup>14</sup> LANG: *Biochemische Zeitschrift*, 1906, ii, pp. 225-242.

<sup>15</sup> LONDON: OPPENHEIMER'S *Handbuch der Biochemie*, 1909, iii, part ii, p. 78.

been expressed a view that the stomach may perform a function specific to itself; one important to the general economy of the organism, one that cannot readily be replaced by the activities of other organs.

The present work was undertaken with the object to test the correctness of the existing views on the function of the stomach. It was originally planned to study the capacity of the organism for protein assimilation and for protein retention after the complete removal of the stomach. It was, however, deemed preferable to begin the study by limiting the operation to a gastroenterostomy, and to let the investigation on dogs with gastrectomy follow.

#### PLAN OF INVESTIGATION.

Dogs after recovery from the operation were placed in nitrogenous equilibrium on a standard diet. The daily intake was divided into five equal portions, which were given to the animal at three-hour intervals. In this manner it was sought to bring about an approximately uniform nitrogen elimination at nearly all hours of the day. The urine was collected by catheterization in three-hour periods. Each catheterization was followed by feeding. To this diet, on the days of special experiment, an additional quantity of protein was administered with the first meal, and the rate of nitrogen elimination was studied. This rate was compared with that obtained on the standard diet and the result again compared with the results of similar experiments on normal dogs. Before going into detailed analysis of the results of the experiments, it may be stated here that the rather surprising observation was made that after gastroenterostomy the rate of nitrogen elimination was considerably higher than in normal animals. On the other hand, the proportion of nitrogen retention seemed rather low. It was therefore concluded in one experiment to continue the diet with the increased protein content for seven days and to estimate the quantity of protein stored up in the organism during that period. The discussion of the results of the experiments will follow.

#### METHOD OF OPERATION.

A hypodermic injection of 0.5 gm. of morphin was given half an hour before the operation. Ether was employed for anesthesia. A median

abdominal incision was made about three inches long. The stomach was drawn out of the abdominal cavity, and a space about two inches long selected on the posterior surface of the fundus. This part of the stomach was emptied of its contents by milking movements of the hand, and closed off by a double tape-ligature from the esophageal and pyloric parts of the stomach. Then a loop of the jejunum, about two inches long, was selected not far from the duodenum, and closed off from the rest of the intestinal tract with a double tape-ligature. The omentum covering the selected part of the stomach was slit, and the serous coat of the stomach united with the serous coat of the intestine by a running suture, parallel to the long axis of the organs, and about one and one half inches long. Then both the stomach and intestine were opened by an incision of the same length and direction as the serous suture. A circular running suture joining all the coats of the organs, and a serous suture over the anterior half of the circular suture completed the anastomosis. The abdominal wound was closed with three layers of sutures.

#### METHODS OF ANALYSIS.

As already stated, urine was collected by catheterization. Total nitrogen was estimated by the Kjeldahl-Gunning process; urea by Benedict and Gephart,<sup>10</sup> and ammonia by Folin-Schaeffer methods.

#### EXPERIMENTS.

*Dog I.* — Dog of 9 kg. weight. The operation consisted of gastroenterostomy. The pyloric end was left intact. The diet of this dog consisted of:

		Gm. N.	Cal.
Plasmon . . . . .	16 gm. containing	1.83	65
Cracker meal . . . . .	80 gm. “	1.33	305
Lard . . . . .	20 gm. “	...	180
Salt . . . . .	5 gm.	...	...
Total intake . . . . .		<u>3.16</u>	<u>550</u>

After equilibrium was established the dog eliminated through the urine 2.82 gm. of nitrogen, of which 2.49 gm. were in the form of urea

<sup>10</sup> BENEDICT and GEPIART: *Journal of the American Chemical Society*, 1908, xxx, p. 1760.

(Table I). The dog was in perfectly good health during the time of all the experiments. At no time was there any vomiting. About six weeks after the operation the dog contracted a general infection, which caused its death.

On this dog two experiments were performed with the addition to the standard diet of 1.85 gm. nitrogen in form of plasmon. On the day of the first experiment (Table II) the nitrogen elimination was as follows:

	Total N.	Urea N.
Plasmon and standard diet . . . . .	4.69 gm.	4.28 gm.
On standard diet . . . . .	2.82 "	2.49 "
Eliminated in excess over the normal . . .	1.87 gm.	1.79 gm.

Thus in this experiment 100 per cent of the additional nitrogen intake was found in the urine during the first twenty-four hours.

On the day of the second experiment (Table III) the nitrogen elimination was as follows:

	Total N.	Urea N.
Plasmon and standard diet . . . . .	4.56 gm.	4.11 gm.
On standard diet . . . . .	2.82 "	2.49 "
Eliminated in excess over the normal . . .	1.74 gm.	1.62 gm.

In this experiment 94 per cent of the additional nitrogen intake was removed through the kidneys within the first twenty-four hours.

These observations were rather unexpected. It was the general experience of all who performed similar experiments on normal animals that after a diet richer in protein than the standard the excessive nitrogen was not removed within the first twenty-four hours. Our results seemed all the more surprising, since recently Fischer and Abderhalden<sup>17</sup> have again demonstrated that protein which has been acted upon by pepsin is digested with greater readiness by trypsin. In our animals with gastroenterostomy the pepsin had little occasion to act on the protein of the food, for the reasons that, first, the foodstuffs do not remain sufficiently long in the stomach, and, second, after this operation the alkaline secretion of the liver, pancreas, and the intestinal wall regurgitate into the stomach and thus neutralize the hydrochloric acid of the gastric juice. A normal dog placed in nitrogenous equi-

<sup>17</sup> FISCHER and ABDERHALDEN: *Zeitschrift für physiologische Chemie*, 1903, XI, p. 215.

librium on a diet of the same character as the one operated upon removed only 51 per cent of the intake during the first twenty-four hours.

Further comparing the curve of elimination of the excessive nitrogen, one notes that in the operated animals the rise is more sudden and reaches its maximum earlier than in normal animals. Thus, in the operated dogs the highest point of the curve is reached in the second period, while in the normal dog this occurred in the third period. Besides, the maximum output of the excessive nitrogen takes place in the operated animal within the first nine hours, thus, in Experiment I, this amounted to 64 per cent, and, in Experiment II to 84.1 per cent of the total excessive elimination. On the other hand, the normal animal under similar conditions eliminated 48.65 per cent of the total excessive nitrogen.

In normal animals a similar character of the curve of elimination of excessive nitrogen is observed only after addition to the standard diet of the very soluble aminoacids (Levene and Meyer).<sup>18</sup> All this seems to suggest that in the operated animal either the rate of digestion or that of absorption is increased.

*Dog II.* — Dog of 9 kg. weight. The dog was operated on the 8th of March. The same procedure as on Dog I. Uneventful recovery from operation. The condition of the dog was good until the latter part of May. Since then it frequently refused its food and it often vomited. On the basis of some earlier experience (Dog III) it was thought possible that the dog developed acute dilatation of the stomach. Therefore a second operation was undertaken on the 14th of June. This operation is described later. After the second operation the condition of the dog improved, but it did not take the usual food readily. The diet was therefore changed to one consisting of beef, which the animal ate ravenously. There was no further vomiting.

On this animal the experiments were planned with a view of solving the question whether the increased rate of elimination in the operated animals was caused by the higher rate of digestion or by that of absorption. For this purpose, glycine, leucine, and gelatin, besides plasmon were added to the standard diet. The aminoacids were selected for the reason that any increase in the rate of elimination of the excessive nitrogen after the administration of them could be the result of only

<sup>18</sup> This journal. Article preceding this.

one factor, namely, the rate of absorption. Gelatin was chosen for the reason that in vitro it is quite resistant to the action of proteolytic enzymes.

Also in these experiments the standard diet consisted of:

		Gm. N.	Cal.
Plasmon . . . . .	20 gm. containing	2.32	80
Cracker meal . . . . .	80 gm. " "	1.42	300
Lard . . . . .	15 gm. " "	...	140
Salt . . . . .	5 gm.	...	...
Total intake . . . . .		<u>3.74</u>	<u>520</u>

The normal output on this diet consisted of 3.18 gm. of nitrogen, of which 2.84 gm. was in form of urea (Table IV).

**Experiment I** (Table V). — In this experiment plasmon with a content of 1.86 gm. of nitrogen was added to the standard diet. The elimination through the urine on the day of the experiment was the following:

	Total N.	Urea N.
Plasmon and standard diet . . . . .	4.72 gm.	4.25 gm.
On standard diet . . . . .	<u>3.18 " "</u>	<u>2.84 " "</u>
Eliminated in excess over the normal . . .	1.54 gm.	1.41 gm.

**Experiment II** (Table VI). — The same as I. The elimination through the urine was:

	Total N.	Urea N.
On standard diet . . . . .	4.63 gm.	4.24 gm.
Plasmon and standard diet . . . . .	<u>3.18 " "</u>	<u>2.84 " "</u>
Eliminated in excess over the normal . . .	1.45 gm.	1.40 gm.

**Experiment III** (Table VII). — Glycocoll equivalent to 1.6 gm. of nitrogen was added to the standard diet. The elimination through the kidneys on the day of experiment was the following:

	Total N.	Urea N.
Glycocoll and standard diet . . . . .	4.74 gm.	4.16 gm.
On standard diet . . . . .	<u>3.18 " "</u>	<u>2.84 " "</u>
Eliminated in excess over the normal . . .	1.56 gm.	1.32 gm.

**Experiment IV** (Table VIII). — The same as Experiment III. Eliminated through the kidneys on the day of the experiment:

	Total N.	Urea N.
Glycocoll and standard diet . . . . .	4.54 gm.	4.28 gm.
On standard diet <sup>19</sup> . . . . .	2.88 "	2.56 "
Eliminated in excess over standard . . . . .	1.66 gm.	1.72 gm.

**Experiment V.** (Table IX). — l-leucin, equivalent to 1 gm. of nitrogen (obtained on hydrolysis of casein and purified by the lead process of Levene and Van Slyke,<sup>20</sup> was added to the standard diet. On the day of the experiment the urine contained:

	Total N.	Urea N.
l-leucin and standard diet . . . . .	3.83 gm.	3.39 gm.
On standard diet . . . . .	2.88 "	2.56 "
Eliminated in excess over standard . . . . .	0.95 gm.	0.83 gm.

**Experiment VI.** (Table X). — Gelatin equivalent to 1.8 gm. of nitrogen was added to the standard diet. On the day of experiment the urine contained:

	Total N.	Urea N.
Gelatin and standard diet . . . . .	4.40 gm.	4.13 gm.
On standard diet . . . . .	2.88 "	2.56 "
Eliminated in excess over standard . . . . .	1.52 gm.	1.57 gm.

Comparing the rate of elimination on the second operated dog with that of the normal, one finds that in all the instances, where the normal dog removed during the first twenty-four hours only a fraction of the additional nitrogen intake, the operated animal removed during the same period the entire, or nearly the entire, intake. Thus, after addition of plasmon over 80 per cent of its nitrogen were removed in the first twenty-four hours, after gelatin 83 per cent, after glycocoll 100 per cent, and after l-leucin 95 per cent. In the normal animal the elimination of the excessive nitrogen for the same period of time were 48, 60, 100, and 55 per cent respectively. The curve of the daily output, after addition of plasmon was of the same character as in the first operated dog, and after the administration of gelatin, glycocoll and leucin it had the same character as in the normal dog.

<sup>19</sup> The elimination on standard diet had changed two months after the operation to 2.88 gm. of nitrogen, of which 2.56 gm. were in form of urea.

<sup>20</sup> LEVENE and VAN SLYKE: *Journal of biological chemistry*, 1909, vi, p. 391.



The increased rate of nitrogen elimination in the operated animal after the administration of leucin can be explained on the basis of increased rate of absorption, when the substance is allowed to enter into the intestinal canal without being detained for any length of time in the stomach. The difference in the rate of elimination of excessive nitrogen after the administration of plasmon and of gelatin is in harmony with the *a priori* considerations. It was stated that gelatin is extremely resistant to the action of proteolytic enzymes. Therefore, although the operated animals showed an increase in the rate of elimination of the excessive nitrogen as compared with the normal animals, yet the increase in the rate takes place not with the same rapidity as after administration of plasmon. In the normal animals the rate of nitrogen elimination after administration of either of the two proteins showed no marked difference. From this it follows that in the operated animals the rate of digestion of plasmon is higher than in the normal animals. Thus it seems suggestive that after gastroenterostomy conditions are created which accelerate digestion and absorption of the products of protein digestion. These considerations seemed to have gained confirmation by observations made on a third dog.

*Dog III.* — Dog of 20 kg. weight. Operated the 25th of February. The pyloric end left intact. The dog was apparently in good health. On the 6th of March the dog was placed on the standard diet consisting of:

		Gm. N.	Cal.
Plasmon . . . . .	30 gm. containing	3.48	120
Cracker meal . . . . .	125 gm. “	1.80	475
Lard . . . . .	20 gm. “	...	185
Salt . . . . .	5 gm.	...	...
Total intake . . . . .		<u>5.28</u>	<u>780</u>

It was difficult to place the dog in a state of nitrogenous equilibrium. There was a continuous retention. However, after some time the daily nitrogen content of the urine seemed to have reached an approximately constant value, varying in four days from 3.70 to 3.80 gm. per day. Experiments with additional feeding were then undertaken. On the day following the one with the nitrogen output of 3.70 gm., plasmon equivalent to 1.39 gm. of nitrogen was added to the standard diet. On the day of the experiment the nitrogen content of

the urine was 4.72 gm.; thus the excessive output was 73.4 per cent of the intake. This is a higher elimination of the excessive nitrogen than occurs in normal animals, but lower than the one observed on the other two operated dogs. After this experiment the daily output gradually fell to 3.46 gm. of nitrogen when a second experiment with additional plasmon, containing 1.39 gm. of nitrogen, was performed. On this occasion the urine contained on the day of the experiment 4.22 gm. of nitrogen, thus showing an elimination of 57.5 per cent of the excessive nitrogen intake. The daily retention of nitrogen continued. Another distressing symptom developed by the dog was vomiting. Many workers have observed vomiting as a nearly constant occurrence in experimental and as a frequent occurrence in clinical gastroenterostomy. Various theories have been adduced in explanation of this symptom. In the present experiment an attempt was made to cope with the situation, and also to prevent the retention of nitrogen by changing the standard diet. The quantity of plasmon was diminished and the cracker meal increased, thus leaving the intake of calories nearly unaltered, and that of the nitrogen intake diminished.

The diet after several attempts was reduced to 16 gm. of plasmon, 200 gm. of cracker meal, and 25 gm. of lard. On this diet the dog was placed in a condition approaching nitrogenous equilibrium. Thus on the first three days of this diet the total nitrogen output was 4.41, 3.97, and 4.50 gm. with a corresponding intake of 4.66 gm. of nitrogen. Nevertheless the animal vomited from time to time, particularly after administration of the additional diet. It was thought possible that the apparent retention of nitrogen and the vomiting were caused by acute dilatation of the stomach. In order to test the correctness of the suspicion, and in order, if possible, to correct the existing condition, a second operation was performed on the 16th of April.

Median incision. The condition found at the operation was the following. The stomach was nearly three times the size of a normal organ, extending to about two inches below the umbilicus, and was filled with solid and liquid material. Between the anastomosis and the pylorus there was formed a sac, resembling a new fundus. The operation of gastroduodenostomy was performed, *i. e.*, an anastomosis was formed between a loop of the duodenum and the deepest part of the newly formed sac. The pylorus was left open.

After the second operation the condition of the dog seemed to improve

temporarily, but after a while the dog refused to take the usual diet and vomiting recurred quite frequently. On the 20th of April the weight of the dog was only 15 kg., and on the 20th of May — 13 kg. It was then attempted to change to a beef diet. The dog ate ravenously, and for a time seemed to improve, but on the 20th of June it died. The autopsy revealed pneumonia as the cause of death.

Thus it was impossible to repeat the experiment with additional protein feeding, but the evidence obtained at the second operation makes it probable that the lower rate of elimination of excessive nitrogen in the third animal, as compared with the first two, was caused by a retention of the food in the dilated stomach.

#### DISCUSSION OF THE RESULTS.

From the results of the experiments thus far recorded in this communication it is obvious that after gastroenterostomy conditions are created that facilitate the digestion of proteins in the gastrointestinal tract and at the same time accelerate the process of absorption. On the other hand, it is known that after the operation the food is transported to the intestinal tract with greater rapidity than normally. Besides, it has been established by many workers<sup>21</sup> that regurgitation of the intestinal juice into the stomach is a constant occurrence after this operation. The gastric juice is neutralized and gastric digestion reduced to a minimum. Therefore the increased rate of digestion in the recorded experiments is accomplished mainly by the intestinal tract. Thus it seems that the preliminary peptic action is not required in order to bring about a complete proteolysis of the ingested protein. The view which attributes to the stomach a function auxiliary to the digestive glands of the intestinal tract seems to harmonize little with the actual facts. On the other hand, the results of the recorded experiments (the rapid elimination of the ingested nitrogen) may serve to interpret the significance of the stomach for the general economy of the organism.

One of the fundamental laws of animal nutrition postulates that every daily increase in the nitrogen intake of an animal in nitrogenous equilibrium is followed by a retention of nitrogen during the first

<sup>21</sup> ROSENBERG: *Archiv für die gesammte Physiologie*, 1898, lxxiii, p. 403; KATZENSTEIN: *Deutsche medicinische Wochenschrift*, 1907, pp. 95-98 and 138-141; SCHOENHEIM: *Boas Archiv*, 1908, xiv, p. 496.

twenty-four hours after the intake. If the same higher intake is repeated for some time, a new equilibrium on the plane of the higher intake is established. This is accomplished after a certain amount of the ingested food is assimilated by the animal. The retention of nitrogen is either an expression of this assimilation, or it is the initial step in the process of assimilation. It is not possible to accomplish a storing up of body protein when nitrogen retention does not follow an excessive protein intake. In the animals with gastroenterostomy under our observation the increase in nitrogen output responded to the increased intake with great promptness, so that under no conditions could be expected a prolonged retention of nitrogen. This assumption was found correct, as seen from the following experiment.

#### EXPERIMENT WITH CONTINUED INCREASE IN NITROGEN INTAKE.

This experiment was performed on Dog II. It was mentioned before that about the end of May the condition of the dog ceased to be satisfactory. The dog vomited and did not take its food readily. It was decided to perform a second operation.

*Dog II. — Second operation, June 14, 1909.* — Median incision. The stomach found enlarged, but not to the same extent as in Dog III. The artificial fundus formation was also not so pronounced. Gastro-duodenostomy was performed, and besides this the pylorus was closed in the following way. A longitudinal incision was made through the serosa and muscularis. Then the mucosa was freed all around the muscularis, doubly ligated and severed, and the incision in the muscularis closed again.

On the 18th the animal was placed on the following diet:

		Gm. N.	Cal.
Beef . . . . .	75 gm. containing	2.50	210
Cracker meal . . . . .	60 gm. " "	1.07	230
Bone ash . . . . .	10 gm.	---	---
Total intake . . . . .		3.57	440

Beginning the 4th of July, three experiments were performed, each lasting seven days. During the first seven days the dog received the

standard diet, the following seven days the nitrogen intake was increased to 5.20 gm. per day. The diet consisted of:

	Gm. N.	Cal.
Beef . . . . . 125 gm. containing	4.13	260
Cracker meal . . . . . 60 gm. "	<u>1.07</u>	<u>230</u>
Total intake . . . . .	5.20	490

In the third period the diet of the first seven days was repeated.

All the time after the second operation the dog was in good health and ate ravenously. During the first seven days the nitrogen intake of the dog was 25 gm. and the output 26.86 gm., showing a loss of 1.86 gm. (Table XIV). During the second period the intake was 36.4 gm. and the output 36.08 gm. Thus practically an equilibrium was established. If, however, it is taken into consideration that on the standard diet the dog should have lost about 1.86 gm. of nitrogen, the established condition might be regarded as a result of the retention of about 2 gm. of nitrogen, which indicates rather a low rate of assimilation. During the third period the intake was again 25 gm. and the output 27.65 gm., showing a loss of over 2 gm., approximately the same as during the first seven days. It is worthy of note that after the first day of the second period the daily retention continued to be very insignificant, and on the sixth and seventh days there was already a slight loss of nitrogen. Again, on changing the diet from a high to a low nitrogen content, there was a marked loss of nitrogen by the animal only on the first day of the period, and already on the second day it came down to the level constant for that diet.

Thus when the activity of the stomach is impaired through a gastroenterostomy the capacity of the organism to store up protein and to retain the stored up protein is diminished. Bearing in mind the increased velocity of digestion, observed under the same conditions, one might be led to attribute the significance of the stomach not to its assistance in the process of digestion, but to its rôle in the process of protein assimilation or protein regeneration.

This assumption is not in discord with facts and theories already recorded. Thus it is the general experience that gastric digestion of protein does not go much beyond the stage of primary digestion products which still possess the general characteristics of protein. If absorption takes place through the gastric wall, substance of protein nature

would be absorbed there and furnished to the tissues. That these substances are of primary importance for protein regeneration is evident from the many failures to maintain nitrogenous equilibrium by mixtures of aminoacids free from all peptones and peptides.<sup>22</sup>

At this place it may be well to recall the views of Falta.<sup>23</sup> Studying the rate of elimination of the nitrogen of protein added to a standard diet, this author noted that it frequently requires for its complete elimination from seventy-two to ninety-six hours. Older observers had demonstrated that protein food does not remain in the gastrointestinal tract more than twenty-four hours. The delay between protein absorption and the elimination of its nitrogen, according to this writer, is due to the fact that only part of the ingested protein is absorbed in the form of its final digestion products, while the other part is absorbed in form of its primary digestion products. The latter part undergoes its final dissolution in the tissues and at a comparatively low rate of digestion. Thus also, in the opinion of Falta, in completely hydrolyzed protein is absorbed from the gastrointestinal canal.

On the other hand, from the experiments recorded in this communication, the conclusion might be reached that in the intestinal tract, digestion proceeds at a high velocity and with great intensity, so that little unhydrolyzed protein is absorbed from there. This naturally makes it suggestive to regard the principal function of the stomach as the absorption of uncompletely digested protein, and thus in a way to regard it as the organ controlling regeneration and storing up of protein in the organism. For the present this view is offered merely as a suggestion, which needs to be tested by further experimentation.

<sup>22</sup> LOEWI: *Archiv für experimentelle Pathologie und Pharmakologie*, 1902, *xlvi*, p. 303; HENRIQUES and HAUREN: *Zeitschrift für physiologische Chemie*, 1905, *xlvi*, p. 417; 1906, *xlvi*, p. 383; 1907, *liv*, p. 169; ABDERHALDEN: Series of articles in *Zeitschrift für physiologische Chemie*, beginning vol. *lxii*.

<sup>23</sup> FALTA: *Deutsche Archiv für klinische Medicin*, 1904, *lxxxi*, p. 231; 1906, *lxxxvi*, p. 517.

TABLES I-III.

TABLE I. STANDARD DIET.

Periods.	Total nitrogen in grams.	Urea nitrogen.		Ammonia nitrogen.		Undetermined nitrogen.	
		Grams.	Per cent of total nitrogen.	Grams.	Per cent of total nitrogen.	Grams.	Per cent of total nitrogen.
I.	0.308	0.270	90.0	0.007	2.4	0.031	10.0
II.	0.454	0.400	90.0	0.005	1.1	0.049	10.0
III.	0.400	0.352	90.0	0.010	2.5	0.038	9.5
IV.	0.410	0.367	90.0	0.006	1.5	0.037	9.0
V.	0.416	0.359	90.0	0.012	2.8	0.045	10.8
VI.	0.832	0.745	90.0	0.008	1.1	0.079	9.5

TABLE II. STANDARD AND PLASMON DIET.

I.	0.623 +0.315 <sup>1</sup>	0.572	92.0	0.005	0.8	0.051	8.2
II.	1.027 +0.573	0.971	94.0	0.014	1.4	0.042	4.1
III.	0.707 +0.307	0.640	90.0	0.004	0.6	0.063	8.0
IV.	0.622 +0.212	0.568	91.0	0.013	2.0	0.042	5.1
V.	0.606 +0.190	0.524	89.6	0.011	1.9	0.071	11.7
VI.	1.104 +0.272	1.009	90.0	0.009	0.9	0.087	7.9

TABLE III. STANDARD AND PLASMON DIET.

I.	0.734 +0.426	0.661	90.0	0.008	1.0	0.065	8.8
II.	1.108 +0.654	1.019	92.0	0.010	0.9	0.089	8.0
III.	0.783 +0.383	0.718	92.0	0.014	1.8	0.051	6.5
IV. V.	{ 1.012 +0.186 }	{ 0.895	{ 90.0	{ 0.021	{ 2.0	{ 0.096	{ 9.5
VI.	0.924 +0.091	0.814	90.0	0.006	0.7	0.104	11.2

<sup>1</sup> These figures show balance with standard diet.

TABLES IV-VI.

Periods.	Total nitrogen in grams.	Urea nitrogen.		Ammonia nitrogen.		Undetermined nitrogen.	
		Grams.	Per cent of total nitrogen.	Grams.	Per cent of total nitrogen.	Grams.	Per cent of total nitrogen.
I.	0.304	0.281	92.0	0.011	3.3	0.012	4.0
II.	0.580	0.519	90.0	0.016	3.3	0.045	7.9
III.	0.494	0.449	91.0	0.015	3.0	0.030	6.0
IV.	0.520	0.463	90.0	0.003	0.6	0.054	10.4
V.	0.483	0.433	90.0	0.013	2.7	0.050	10.4
VI.	0.801	0.698	87.3	0.034	4.2	0.069	8.6

TABLE V. STANDARD AND PLASMON DIET.

I.	0.665 +0.361	0.621	93.3	0.006	0.9	0.038	5.9
II.	1.064 +0.484	0.991	93.0	0.018	1.7	0.055	5.2
III.	0.781 +0.349	0.732	93.7	0.011	1.4	0.038	4.9
IV.	0.551 +0.031	0.500	90.0	0.010	1.7	0.041	7.5
V.	0.542 +0.059	0.503	93.0	0.003	0.5	0.036	6.7
VI.	1.117 +0.216	1.006	90.0	0.031	3.8	0.080	7.2

TABLE VI. STANDARD AND PLASMON DIET.

I.	0.553 +0.189	0.509	92.0	0.004	0.7	0.015	2.8
II.	1.087 +0.567	1.014	91.5	0.003	0.3	0.070	6.3
III.	0.759 +0.265	0.691	90.5	0.006	0.8	0.062	8.2
IV.	0.729 +0.187	0.690	94.0	0.010	1.4	0.029	4.0
V.	0.505 +0.122	0.462	91.5	0.009	2.0	0.034	6.7
VI.	0.996 +0.196	0.870	89.5	0.050	5.0	0.076	7.7



TABLES VII-IX.

TABLE VII. STANDARD AND GLYCOL DIET.

Periods.	Total nitrogen in grams.	Urea nitrogen.		Ammonia nitrogen.		Undetermined nitrogen.	
		Grams.	Per cent of total nitrogen.	Grams.	Per cent of total nitrogen.	Grams.	Per cent of total nitrogen.
I.	0.491 +0.123	0.463	94.5	0.005	1.0	0.023	4.7
II.	1.028 +0.508	0.871	85.0	0.014	1.3	0.143	13.9
III.	0.755 +0.261	0.695	92.0	0.002	1.8	0.037	6.5
IV.	0.890 +0.370	0.806	90.0	0.001	0.2	0.073	8.2
V.	0.475 -0.038	0.417	90.0	0.027	2.6	0.059	12.4
VI.	1.098 +0.297	0.910	83.0	0.110	3.3	0.161	14.6

TABLE VIII. STANDARD AND GLYCOL DIET.

I.	0.749 +0.445	0.707	93.0	0.018	2.4	0.024	3.2
II.	0.932 +0.252	0.862	91.6	0.004	0.4	0.066	7.0
III.	0.690 +0.196	0.660	95.6	0.004	0.6	0.025	3.6
IV.	0.648 +0.128	0.600	92.4	0.062	1.0	0.042	6.5
V.	0.510 +0.027	0.466	91.4	0.011	2.0	0.033	6.4
VI.	1.008 +0.207	0.988	98.0	0.015	1.5	0.019	1.8

TABLE IX. STANDARD AND LEUCIN DIET.

I.	0.331 +0.027	0.296	87.3	0.009	2.9	0.031	9.1
II.	0.600 +0.020	0.575	95.8	0.006	1.0	0.019	3.1
III.	0.577 +0.083	0.544	94.0	0.009	1.7	0.033	5.7
IV.	0.610 +0.090	0.536	90.0	0.005	0.9	0.049	8.0
V.	0.542 +0.059	0.507	94.0	0.007	1.3	0.028	5.4
VI.	1.168 +0.367	0.932	80.0	0.028	2.8	0.136	12.8

TABLES X-XII.

TABLE X. STANDARD AND GELATIN DIET.

Periods.	Total nitrogen in grams.	Urea nitrogen.		Ammonia nitrogen.		Undetermined nitrogen.	
		Grams.	Per cent of total nitrogen.	Grams.	Per cent of total nitrogen.	Grams.	Per cent of total nitrogen.
I.	0.372	0.337	90.6	0.002	0.4	0.015	4.0
II.	0.875 +0.068	0.838	95.8	0.007	0.8	0.030	3.4
III.	0.854 +0.195	0.824	96.8	0.010	1.2	0.020	2.3
IV.	0.611 +0.360	0.584	95.7	0.008	1.3	0.019	3.1
V.	0.538 +0.091	0.502	93.3	0.011	2.0	0.036	6.7
VI.	1.149 +0.055 +0.348	1.044	90.1	0.051	4.5	0.054	4.9

TABLE XI. STANDARD AND PLASMON DIET.

I.	0.607	0.498	82.0	0.017	2.8	0.0920	15.1
II.	1.010	0.778	78.0	0.027	2.6	0.205	20.3
III.	0.727	0.644	88.6	0.018	2.5	0.065	9.0
IV.	0.664	0.511	77.0	0.027	4.0	0.106	16.4
V.	0.577	0.487	84.4	0.031	5.3	0.059	10.2
VI.	1.140	0.980	80.0	0.084	7.3	0.148	13.0

TABLE XII. STANDARD AND PLASMON DIET.

I.	0.325	0.239	73.0	0.018	5.5	0.068	20.9
II.	0.607	0.532	87.7	0.010	1.6	0.065	10.7
III.	0.694	0.639	92.0	0.012	1.8	0.043	6.2
IV.	0.724	0.628	86.5	0.038	5.2	0.058	8.0
V.	0.548	0.471	86.0	0.023	4.6	0.054	9.8
VI.	1.320	1.050	80.0	0.110	8.0	0.160	12.1

TABLE XIII.

No. of table.	Diet.	Total nitrogen.	Urea nitrogen.		Ammonia nitrogen.		Undetermined nitrogen.		Feces.	Output.	Intake.	Balance.
			Grams.	Per cent of total nitrogen.	Grams.	Per cent of total nitrogen.	Grams.	Per cent of total nitrogen.				
I.	Standard . . . . .	2.82	2.49	90.0	0.048	1.7	0.28	9.9	....	2.82	3.16	....
II.	Standard and plasmon . . .	4.69	4.28	91.2	0.10	2.6	0.31	6.6	....	4.69	5.01	....
III.	Standard and plasmon . . .	4.56	4.11	90.0	0.06	1.3	0.39	8.5	....	4.56	5.01	....
IV.	Standard . . . . .	3.18	2.84	90.0	0.07	2.2	0.27	8.4	1.01	4.19	3.74	-0.45
V.	Standard and plasmon . . .	4.72	4.25	90.0	0.08	1.7	0.39	8.3	0.94	5.76	5.60	-0.16
VI.	Standard and plasmon . . .	4.63	4.24	90.0	0.09	1.9	0.30	6.5	0.94	5.57	5.60	+0.03
VII.	Standard and glycol . . .	4.74	4.16	90.0	0.19	3.8	0.39	8.2	0.76	5.50	5.34	-0.16
VIII.	Standard and glycol . . .	4.54	4.28	94.0	0.11	2.4	0.15	3.3	0.47	4.98	5.34	+0.36
IX.	Standard and leucin . . . .	3.83	3.39	88.0	0.064	1.7	0.38	9.9	1.12	4.95	4.74	-0.21
X.	Standard and gelatin . . .	4.40	4.13	94.0	0.09	2.0	0.18	4.4	0.67	5.07	5.54	+0.47
XI.	Standard and plasmon . . .	4.72	3.90	82.7	0.20	4.2	0.62	11.0	1.33	6.05	6.67	+0.62
XII.	Standard and plasmon . . .	4.22	3.56	84.3	0.21	5.0	0.45	10.7	1.01	5.23	6.67	+0.44
	Standard . . . . .	3.44	2.88	83.6	0.17	4.9	0.39	11.3	0.97	4.41	4.66	+0.25
	Standard . . . . .	3.39	2.87	73.0	0.15	4.0	0.37	11.0	0.58	3.97	4.66	+0.69
	Standard . . . . .	3.83	2.79	73.0	0.52	13.6	0.52	13.6	0.67	4.50	4.66	+0.16

TABLE XIV.

Date.	Diet.	Total N.	Urea N.		Ammo
			Grams.	Per cent of total N.	Grams.
4	60 gm. cracker dust . . .	3.15	2.71	86.0	0.17
5	75 gm. beef . . . . .	2.93	2.45	83.6	0.18
6	10 gm. bone ash . . . . .	3.13	2.65	85.0	0.13
7	5 gm. sodium chloride .	3.19	2.94	84.2	0.12
8	.....	3.49	3.05	88.0	0.11
9	.....	3.46	3.05	88.1	0.23
10	.....	3.60	3.15	87.5	0.18
Sum 4-10	.....	22.95	20.00	86.06	1.12
11	60 gm. cracker dust . . .	4.20	3.55	84.5	0.15
12	.....	4.70	4.16	88.5	0.16
13	120 gm. beef . . . . .	4.60	3.88	84.3	0.23
14	10 gm. bone ash . . . . .	4.55	4.00	89.0	0.20
15	5 gm. sodium chloride	4.52	4.08	90.0	0.21
16	.....	4.25	3.66	84.7	0.13
17	.....	4.89	4.36	89.9	0.19
Sum 11-17	.....	31.71	27.69	87.2	1.27
18	.....	3.84	3.22	83.9	0.24
19	76 gm. cracker dust . . .	3.36	2.78	83.3	0.23
20	.....	3.36	2.74	81.6	0.23
21	66 gm. beef . . . . .	3.26	2.76	84.6	0.19
22	10 gm. bone ash . . . . .	3.14	2.65	84.4	0.11
23	5 gm. sodium chloride .	3.57	3.27	88.4	0.07
24	.....	3.57	3.22	88.0	0.14
Sum 18-24	.....	24.10	20.64	84.9	1.21

TABLE XIV.

nia N.	Undetermined N.		Feces.	Output.	Intake.	Balance.
	Grams.	Per cent of total N.				
5.8	0.27	8.6	0.60	3.75	3.57	-0.18
6.1	0.30	10.2	0.75	3.68	3.57	-0.11
4.0	0.35	10.5	0.50	3.63	3.57	-0.06
3.7	0.13	4.1	0.49	3.68	3.57	-0.11
3.0	0.33	9.4	0.40	3.89	3.57	-0.32
6.5	0.18	5.2	0.76	4.22	3.57	-0.65
5.0	0.27	7.5	0.41	4.01	3.57	-0.44
4.3	1.83	7.9	3.91	26.86	24.99	-1.87
3.5	0.50	11.9	0.60	4.80	5.20	+0.70
3.4	0.38	8.1	0.46	5.16	5.20	+0.04
4.5	0.49	10.5	0.53	5.13	5.20	+0.01
4.4	0.35	7.7	0.59	5.14	5.20	+0.06
4.3	0.23	5.1	0.60	5.12	5.20	+0.08
3.0	0.45	10.8	1.09	5.34	5.20	-0.14
4.0	0.34	7.0	0.50	5.39	5.20	-0.19
3.9	2.74	8.7	4.37	36.08	36.40	+0.32
6.2	0.38	10.0	0.48	4.32	3.58	-0.74
6.8	0.35	10.4	0.53	3.89	3.58	-0.31
7.0	0.39	11.3	0.43	3.79	3.58	-0.21
5.5	0.29	9.0	0.52	3.78	3.58	-0.20
3.4	0.38	12.0	0.62	3.76	3.58	-0.18
2.0	0.23	6.4	0.53	4.10	3.58	-0.42
3.9	0.21	5.9	0.44	4.01	3.58	-0.43
4.9	2.23	9.3	3.55	27.65	25.06	-2.49

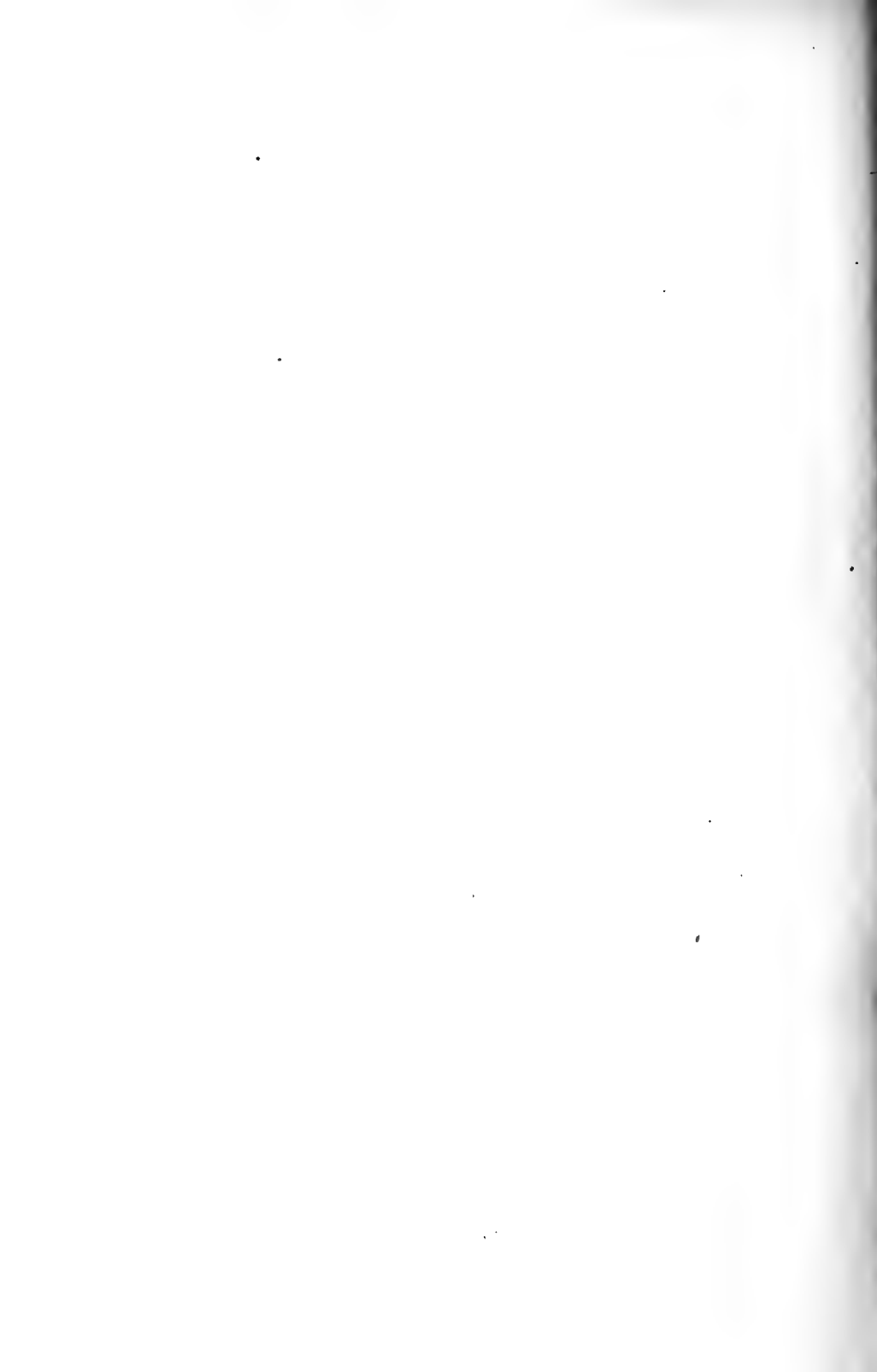

# STUDIES IN EXPERIMENTAL GLYCOSURIA.—V. THE DISTRIBUTION OF GLYCOGENOLYTIC FERMENT IN THE ANIMAL BODY, ESPECIALLY OF THE DOG.

By J. J. R. MACLEOD AND R. G. PEARCE.

[From the Physiological Laboratory, Western Reserve University, Cleveland, O.]

## CONTENTS.

Introduction . . . . .	255
Methods of investigation . . . . .	257
<i>a.</i> General . . . . .	257
<i>b.</i> Methods for the comparison of the amount of glycogenolytic ferment in extracts of solid tissues with that in blood serum . . . . .	264
Comparison of the glycogenolytic strengths of extracts of various organs and tissues with that of blood serum in the dog . . . . .	266
The relative glycogenolytic power of serum and liver extract in the dog . . . . .	271
The influence of reaction on the glycogenolytic activities of serum and liver extract . . . . .	276
Variations in the glycogenolytic power of blood serum and of liver in different dogs . . . . .	277
The relative glycogenolytic power of the liver and blood serum in the sheep, pig, and rabbit . . . . .	282
Discussion of results . . . . .	286
Conclusions . . . . .	290

## INTRODUCTION.

NUMEROUS as have been the investigations relating to the diastatic ferments found in the animal body, very little that is definite is known about them. The relative distribution of these ferments in the various organs and tissues of the animal body, the seat of their production, the most favorable conditions for their action, the specificity of their action, and a multitude of related questions have indeed been the subject of numerous investigations; but the results of these have been uncertain and frequently contradictory, and at present all that we can assert with confidence is that diastatic ferments are plentifully distributed in the animal body, in its fluids and tissues and in several of its secretions.

It has been a much discussed question whether the conversion of glycogen in the liver is the result of the action of a ferment present in the blood or lymph bathing the liver cells, or whether it is a product of the

so-called vital activity of the hepatic cells. By the advance of our knowledge during recent years it is known that the chemical transformations which are results of the activity of cells are brought about by intracellular or endo-enzymes; by ferments, that is to say, which effect their transformations within the protoplasm of the cell. In the case of the glycogenolytic function of the liver a modern statement of the above question would therefore be: is the transformation of glycogen by the liver a result of the action of an intracellular or an extracellular enzyme? This form of statement of the question has had the effect of diminishing its importance in the eyes of some investigators. They agree to rest the case with the verdict that *some* ferment is responsible for the transformation, and that this may be intracellular or extracellular. But it is of prime importance to know which, for the control which the nervous system undoubtedly exercises over the glycogenic function of the liver must act in a very different manner in the two cases.

It has been known for long that the blood serum has a strongly marked diastatic action, and several views have been offered as to the probable seat of production of the ferment which endows it with this. The question is evidently a most fundamental one in connection with the whole problem of carbohydrate metabolism, and yet, for want of uniformity in the methods employed in making comparison of the diastatic power of different organs and tissues, a solution of it has not as yet been satisfactorily made.

From a biochemical point of view few more important discoveries have been made within recent years than those relating to the specificity of action of ferments. This is perhaps best exemplified in the case of those ferments which accelerate the hydrolysis of the disaccharides; maltase, lactase, invertase, etc., being remarkably specific in their action. If this can be definitely proven to be the case for these ferments, it would lead one to expect that for the various polysaccharides there are also specific diastases; for example, that glycogen is acted on by a *glycogenase*, which will have only a feeble action, or no action whatsoever, on starch, and, further, that for the different varieties of starches similar specific ferments will exist. So far, however, nothing definite has been worked out regarding these possibilities.

To compare the amount of soluble ferment in one solid tissue or organ with that in another is not so difficult a matter as is the comparison of the amount of ferment in a solid organ with that in a tissue fluid, such



as blood or lymph. For example, in making an accurate comparison of the amount of diastatic ferment in blood with that in liver, how are we to proceed? It is to be expected that the enzymatic power of an extract of liver will vary considerably according to the method used in preparing the extract; and it is evident that when extracts from different solid tissues are compared as to their relative strengths, the result will be comparable so long as the details of the method are accurately followed in the preparation of the extract from each tissue. When, however, we attempt to compare the action of this extract with that of blood serum or other tissue fluid, it is evidently paramount, not only that some adequate means be employed to liberate the endo-enzymes, but also that we have some means of knowing what volume of moist tissue substance each unit of the extract corresponds to. At first sight it would appear simplest for the above purpose to take the minced tissue itself instead of an extract of it. The objection to this is, however, that the enzymes which are locked up within the body of the cells of the tissue are not set free, but are removed from the substrat, on which they would otherwise act, by an envelope of protoplasm, which, if still alive, may or may not permit contact of enzyme and substrat and which, if dead, may be quite impervious. It is evidently necessary for us to disintegrate the cell itself and thus to set free the enzyme. The pertinence of this criticism has been well illustrated by Buchner and his co-workers in the case of yeast. A saline extract of yeast shows little fermentative activity, but an extract made under great pressure in an hydraulic press possesses remarkable fermentative powers.

In the present paper we shall therefore, first of all, review critically the methods which previous investigators in this field have employed in making extracts of organs for the purpose of comparing their relative diastatic powers. In this connection we shall also consider the various methods that have been used for ascertaining the relative diastatic power of these extracts.

#### METHODS OF INVESTIGATION. — *a* GENERAL.

A comparison of the amount of glycogen in minced blood-free liver after incubation for a certain time with that present in another portion before incubation has been used, especially by Bang, Ljungdahl and

Bohm,<sup>1</sup> to determine the activity of the glycogenolytic ferment. Neilson and Terry,<sup>2</sup> Hanselmann,<sup>3</sup> Pugliese and Domenichini,<sup>4</sup> have also employed somewhat similar methods. The method is, however, one of doubtful value, for, as already pointed out, the intracellular enzymes are, under such conditions, more or less unable to become active, being locked up in the body of the cell.

A saline extract of the liver, prepared by grinding the minced tissue in a mortar with quartz sand so as to disintegrate the cells and then pressing out with a hand press, has been employed by Zegla.<sup>5</sup> Wohlge-muth<sup>6</sup> used extracts prepared in the same way as that prepared by Buchner for the zymase of yeast.

Several observers, including Pavy,<sup>7</sup> Pick,<sup>8</sup> Bainbridge and Beddard,<sup>9</sup> Mendel and Saiki,<sup>10</sup> mixed minced liver thoroughly with several volumes of alcohol, allowed the precipitate to stand under alcohol for several days, then collected it on a filter and, after washing with alcohol, dried it at a low temperature or *in vacuo* and added a weighed amount of the resulting powder to a starch or glycogen solution; or, after removal of the alcohol from the precipitate, made a saline extract of it and employed a measured volume of this.

Before describing some investigations which we have made on the relative value of these methods it will be well to say something about the manner by which previous investigators have estimated the diastatic power of their preparations. As has already been pointed out, the importance of knowing this rests in the fact that there may possibly be a difference between amylase and glycogenase.

Salkowski,<sup>11</sup> Carlson and Ryan,<sup>12</sup> Carlson and Luckhardt,<sup>13</sup> and

<sup>1</sup> BANG, LJUNDAHL, and BOHM: Beiträge zur chemischen Physiologie und Pathologie, 1907, ix, p. 408; 1907, x, p. 1; 1907, x, p. 312.

<sup>2</sup> NEILSON and TERRY: This journal, 1905, xiv, p. 105.

<sup>3</sup> HANSELMANN, H.: Zeitschrift für physiologische Chemie, 1909, lxi, p. 265.

<sup>4</sup> PUGLIESE and DOMENICHINI: Archives italiennes de biologie, 1907, xlvii, p. 1.

<sup>5</sup> ZEGLA, P.: Biochemische Zeitschrift, 1909, xvi, p. 111.

<sup>6</sup> WOHLGEMUTH, J.: Biochemische Zeitschrift, 1908, ix, p. 1.

<sup>7</sup> PAVY, F. W.: The journal of physiology, 1897, xxii, p. 391.

<sup>8</sup> PICK: Beiträge zur chemischen Physiologie und Pathologie, 1902, iii, p. 163.

<sup>9</sup> BAINBRIDGE and BEDDARD: The biochemical journal, 1907, ii, p. 89.

<sup>10</sup> MENDEL and SAIKI: This journal, 1908, xxi, p. 64.

<sup>11</sup> SALKOWSKI: Archives für pathologie (Virchow), 1888, cxx, p. 343.

<sup>12</sup> CARLSON and RYAN: This journal, 1908, ii, p. 1.

<sup>13</sup> CARLSON and LUCKHARDT: This journal, 1908, xxiii, p. 148.

Schlesinger<sup>14</sup> used a starch solution and determined the rate of hydrolysis of the starch by seeing how long it took for the blue reaction with iodine or the opalescence of the solutions to disappear. Wohlgemuth,<sup>15</sup> Zegla,<sup>16</sup> etc., add increasing quantities of the ferment solution to a series of tubes containing equal quantities (5 c.c.) of 1 per cent starch solution, incubate for a definite time, and then see in which of the tubes the blue reaction with iodine has just disappeared. They then calculate how much starch solution would be thus far hydrolyzed by 1 c.c. of the ferment solution. They call this value D. The value which they get is, however, quite misleading, for a slight error in judgment as to which solution of the series just shows disappearance of the blue reaction will cause a great error in D. It is our judgment that Salkowski's method when carefully carried out is far more reliable. Pugliese and Domenichini<sup>17</sup> also used starch solution, but estimated the extent of hydrolysis after a given time by the amount of reducing substance which became formed. On the other hand, Neilson and Terry,<sup>18</sup> Hanselmann,<sup>19</sup> and Pick<sup>20</sup> employed glycogen solutions and determined after a given time how much of this was unchanged. Bang,<sup>21</sup> etc., also added glycogen to many of his preparations of minced liver, and in all cases he determined how much glycogen was left after incubation. Mendel and Saiki<sup>22</sup> used glycogen solutions, but determined the extent of hydrolysis by the amount of reducing substance produced in a given time. Bial<sup>23</sup> used liver pulp and after incubation determined the amount of reducing substance. For blood serum he added 1 per cent starch solution, likewise estimating the reducing power after incubation. In all methods in which the reducing power of the sugar produced by the diastatic activity is estimated, serious errors are apt to be incurred because of the

<sup>14</sup> SCHLESINGER: Deutsche medicinische Wochenschrift, 1908, xxxiv, p. 593.

<sup>15</sup> WOHLGEMUTH: *Loc. cit.*

<sup>16</sup> ZEGLA, P.: Biochemische Zeitschrift, 1909, xvi, p. 111.

<sup>17</sup> PUGLIESE and DOMENICHINI: Archives italiennes de biologie, 1907, lvii, p. 1.

<sup>18</sup> NEILSON and TERRY: This journal, 1905, xiv, p. 105.

<sup>19</sup> HANSELMANN, H.: Zeitschrift für physiologische Chemie, 1909, lxi, p. 265.

<sup>20</sup> PICK: Beiträge zur chemischen Physiologie und Pathologie, 1902, iii, p. 163.

<sup>21</sup> BANG, LJUNGDAHL, and BOHM: Beiträge zur chemischen Physiologie und Pathologie, 1907, ix, p. 408; 1907, x, p. 1; 1907, x, p. 312.

<sup>22</sup> MENDEL and SAIKI: This journal, 1908, xxi, p. 64.

<sup>23</sup> BIAL, M.: Archiv für die gesammte Physiologie, 1894, lv, p. 434.

action of glycolytic ferments. These destroy the sugar at a varying rate and are present in considerable amounts in liver tissue.<sup>24</sup>

We are not as yet in a position to say whether there are specific diastases for the hydrolysis of glycogen and starch, this problem being at present under investigation in this laboratory by Haskins and Zucker. In the present investigation, however, we have in most of our experiments carried out parallel observations on starch and glycogen solutions, using, for the determination of the hydrolysis of starch, the disappearance of the iodine blue reaction — much in the same way as recommended by Wohlgemuth and Schlesinger — and, for the determination of glycogen hydrolysis, the amount of glycogen remaining after incubation for a certain time. The results by the two methods have in general been parallel, although we believe that they are more reliable and more easy of quantitative expression when the glycogen method is employed.

Since, furthermore, the diastases of the tissues do not under natural conditions come in contact with starch but only with glycogen, it has been deemed advisable in these investigations to pay more attention to the results obtained with glycogen solutions than to those obtained with starch solutions.

To compare the relative efficiency of the various methods that have been employed for studying the glycogenolytic power of the liver, we have proceeded as follows. After bleeding an anesthetized dog to death, the liver was washed through the portal vein with 0.9 per cent NaCl solution until thoroughly free of blood, then cut it into thin slices and pressed between filter paper so as to remove as much of the saline as possible. The following experiments were then performed:

1. To each of three solutions of 20 c.c. each of 1 per cent glycogen was added 1 gm. of liver. One solution (*a*) was immediately heated with an equal volume of 60 per cent KOH. The other two (*b* and *c*) were placed in the incubator at 40° C., and one of them (*b*) left for two, the other (*c*) for four hours.

2. The above experiment was repeated with the difference that before weighing out the liver it was minced and bruised in a mortar.

<sup>24</sup> MAGNUS LEVY: *art.* Die Kohlehydrate im Stoffwechsel, Handbuch der Biochemie, iv, first half, p. 332.

3. Ten grams minced liver were thoroughly bruised in a mortar with pure quartz sand and 10 c.c. of a 0.9 per cent solution of sodium chloride. The extract was strained through muslin, and 2 c.c. of it added to each of the three glycogen solutions, which were then treated as described under 1.

4. One hundred grams minced liver were thoroughly ground in a mortar with pure quartz sand (5 gm.) and infusorial earth (12.5 gm.), enclosed in stout canvas and placed in a Buchner press, and the pressure raised to 300 atmospheres. By this treatment a milky fluid was obtained, of which portions of 2 c.c. each were added to three glycogen solutions and treated as above described.

5. One hundred and eleven and five tenths grams minced liver were thoroughly ground in a mortar with 220 c.c. 96 per cent alcohol, the mixture placed in a tightly closed glass vessel for two days, then filtered, the precipitate washed with alcohol and dried during several days over sulphuric acid at low pressure and thoroughly pulverized. The dried powder weighed 22.3 gm. Three portions of 0.2 gm. each of this powder (corresponding to 1.0 gm. moist liver) were then added to three glycogen solutions and treated as above described.

After incubating for the above periods of time, the preparations were heated on a water bath with equal volumes of 60 per cent KOH and the glycogen estimated by Pflüger's method, with the results shown in Table I.

No glycogenolysis occurred in four hours in Nos. 1 and 2; it was moderate in No. 3 and marked in Nos. 4 and 5.

The first two experiments differ from the others in that no means were taken to break up the liver cells. In Nos. 3 and 4 the grinding with quartz sand in the mortar had evidently affected this, although less thoroughly in No. 3 than in No. 4. The treatment with alcohol, No. 5, would appear to have most effectively liberated the enzyme.

In this experiment no toluol was added, since in the short period of incubation employed no bacterial action would be expected, in leed, as shown by the results of Nos. 1 and 2, had certainly not occurred.

In another experiment of the same nature incubation was allowed to go on for eight instead of four hours in order to see if in this time autolytic processes would liberate the ferment in those cases in which disruption of the cells by mechanical means had not been employed.

For brevity's sake we will report these results in terms of the amount

of glycogen-dextrose which disappeared in per cent of the original amount of glycogen present (percentile glycogenolysis):

TABLE I.  
THE RELATIVE GLYCOGENOLYTIC STRENGTH OF PREPARATIONS OF BLOOD-FREE LIVER MADE IN VARIOUS WAYS.<sup>1</sup>

No.	Nature of experiment.	Amount of glycogen left.	Amount disappeared.	Amount disappeared in per cent of original amount.	Time of incubation.	
		gm.	gm.		hr.	
1	Pieces of liver	a . . . . .	0.1295	....	....	..
		b . . . . .	0.1282	none	0	2
		c . . . . .	....	....	....	4
2	Minced liver	a . . . . .	0.1306	....	....	..
		b . . . . .	0.1369	none	0	2
		c . . . . .	0.1297	none?	0	4
3	Saline extract	a . . . . .	0.1251	....	....	..
		b . . . . .	....	....	....	2
		c . . . . .	0.1114	0.0137	10.9	4
4	Buchner extract	a . . . . .	0.1231	....	....	..
		b . . . . .	0.1010	0.0221	17.9	2
		c . . . . .	0.0924	0.0307	24.9	4
5	Alcohol ppt.	a . . . . .	0.1181	....	....	..
		b . . . . .	0.1132	....	....	2
		c . . . . .	0.0803	0.0378	32	4

<sup>1</sup> The results are given as dextrose.

One gram washed liver plus 20 c.c. glycogen showed 30 per cent glycogen disappeared.

One c.c. saline extract corresponding to 0.5 gm. liver (prepared as described in No. 2 of previous experiment) gave 28.6 per cent.

One c.c. Buchner extract gave 34.4 per cent.

Two tenths gram dried liver powder (corresponding to 1 gm. liver) gave 32.6 per cent.

In this experiment considerable glycogenolysis had occurred in the preparations containing pieces of intact liver, probably because in the longer time of incubation autolytic disintegration of the liver cells had liberated the intracellular glycogenase. Bacterial growth may also have been partly responsible. The saline and Buchner extracts, however, showed distinctly more glycogenolysis than the pieces of liver, for with an amount of saline extract corresponding to one half of the amount of liver used in No. 1, 28.6 per cent of glycogen was decomposed and 1 c.c. of Buchner extract decomposed 34.4 per cent. Later we will discuss what amount of such an extract can be considered as equivalent to 1 gm. of liver.

In this experiment, as in the previous one, the extract prepared by Buchner's method and the alcohol precipitate showed the most rapid glycogenolysis.

A considerable amount of the work on the glycogenolytic ferment of liver has been done with alcohol precipitates, or with dilute saline extracts of these. Contradictory statements exist in the literature, however, as to the reliability of this method. Pick,<sup>25</sup> for example, states that the treatment with alcohol increases the glycogenolytic power, and Bial,<sup>21</sup> that by prolonged action of the alcohol the power decreases. Vernon<sup>27</sup> also found that alcohol rapidly destroys the diastatic action of glycerine extracts of pancreas. Schöndorff and Victorow<sup>28</sup> have, however, found that alcohol does not diminish the amyolytic activity of liver. In one observation by us with a liver which proved itself to be quite active when a Buchner extract was employed (38.1 per cent glycogenolysis in three hours), a water extract of an alcohol precipitate of the same liver that had stood under alcohol for several weeks was found to possess no glycogenolytic action even after six hour's incubation.

Since, for Buchner's process, considerable quantities of tissue and a considerable expenditure of time are necessary, and since for other

<sup>25</sup> PICK: *Loc. cit.*

<sup>26</sup> BIAL: *Archiv für die gesammte Physiologie*, 1893, liv, p. 72.

<sup>27</sup> VERNON: *The journal of physiology*, 1903, xxix, p. 302.

<sup>28</sup> SCHÖNDORFF and VICTOROW: *Archiv für die gesammte Physiologie*, 1907, cxvi, p. 495.

purposes we desire to have a method for rapidly preparing extracts of maximal strength from small amounts of tissue, we have further investigated the relative glycogenolytic powers of saline and Buchner extracts of the same washed liver. In doing this, the Buchner extract and the residue in the canvas were mixed with an equal volume of 0.9 per cent NaCl solution and again expressed in the press so as to yield a preparation of the same dilution as the saline extract.

The experiments were conducted as above described, and the following results were obtained:

1. Saline extract in 2 hours gave 4 per cent glycogenolysis and in four hours — 30 per cent.
2. Buchner extract in two hours gave 10.3 per cent glycogenolysis, and in four hours 25.3 per cent.

From the above experiments it would appear that a water or dilute saline extract is as strong in glycogenase as a Buchner extract of the same dilution, provided the liver be thoroughly crushed with quartz sand in a large mortar. The Buchner process is, however, more reliable.

#### **b. METHODS FOR COMPARISON OF THE AMOUNT OF FERMENT IN EXTRACTS OF SOLID TISSUES WITH THAT IN BLOOD SERUM.**

If a very much greater strength of ferment be found present in an extract of some organ than is present in an approximately equal volume of serum, then this organ must either be the seat of production of the ferment or it must have the power of storing up the ferment carried to it by the blood. If, on the other hand, a tissue be passive towards the ferment — be neither its site of production nor capable of absorbing it — then an amount of extract of such tissue which is equivalent to the amount of serum used for comparison will be feeble in ferment power, and the degree of this will depend on whether the cells of the tissue are pervious to the ferment or whether they are impervious.

To determine the source of the glycogenolytic ferment in blood it is essential that we possess some means by which we can tell how much extract, as prepared by one or other of the above-described methods, is equivalent to a volume of tissue equal to the volume of blood serum used. It is of course impossible to carry out these conditions with perfect accuracy. If we assume that 1 gm. of moist tissue is equivalent to



1 c.c. of serum, then, when minced or dried tissue is used, the above comparison is easily made. When, however, a Buchner extract or a saline extract is employed, we cannot know offhand what volume of the extract is equivalent to 1 gm. of liver.

If instead of being extracts these were suspensions of the tissue, then, by determining the dry residue of a given volume of the suspension, it would be an easy matter to find how much corresponded to 1 gm. of tissue. Being extracts filtered through canvas, however, they will contain only the more soluble and more finely suspended particles of the tissue, but none of the sustentacular meshwork, and a dry-weight determination will only very approximately tell us how much should be taken as equivalent to 1 gm. of the tissue. There is, however, no better method at our disposal, and we have accordingly adopted this one.

In nearly every case in which the dry residue of a Buchner extract of liver was determined by us, it was found to be about 18 per cent of the extract. Liver tissue itself gives a residue of 25 per cent, so that by comparing 1 c.c. of Buchner extract with 1 c.c. of serum, we are certainly taking an amount of extract which comes from considerably more than 1 gm. of moist liver. The high percentage of dry substance in the Buchner extracts of liver is due to the comparatively small amount of connective tissue which this viscus contains. In the case of muscle, kidney, and intestine, Buchner extracts of which have also been used by us in the present investigation, the percentage of dry substance was much less, because of the relatively high proportion of connective tissue.

The following figures give the percentage amount of dry substance in several of the Buchner extracts employed by us:

*Liver*, (Exp. G) 17.29; (Exp. I) 16.1; (Exp. J) 9.9 (extract was diluted with equal volume of water); (Exp. M) 18.6; (Exp. P) 17.2.

*Muscle*, (Exp. J) 9.6; (Exp. M) 10.0.

*Kidney*, (Exp. J) 11.6; (Exp. M) 8.3.

*Intestine*, (Exp. I\*) 6.9; (Exp. J) 7.5.

Although, therefore, a dry-weight estimation is of no value in comparing Buchner extracts of one tissue with those of another, it is yet of value in telling us whether the Buchner extracts prepared at different times from a given tissue are of constant strength. The above figures demonstrate that in our research these conditions have been fulfilled.

## COMPARISON OF THE GLYCOGENOLYTIC STRENGTHS OF EXTRACTS OF VARIOUS ORGANS AND TISSUES WITH THAT OF BLOOD SERUM.

After bleeding an anesthetized dog to death, a cannula was inserted in the descending aorta, the inferior vena cava cut across, and 0.9 per cent sodium chloride solution perfused through the abdominal area and hind limbs until every trace of blood had been washed out of the vessels. The liver, kidneys, intestine, and a portion of the muscles of the hind limb were then cut in slices, pressed between filter paper, minced, and Buchner extract prepared as above described. An extract was also made of the pancreas by grinding this in a mortar with quartz sand and ten times its volume of 0.9 per cent NaCl solution and filtering through muslin.

Quantities of 20 c.c. each of 1 per cent solution of glycogen were then placed in a series of small flasks, three such being taken for each extract. Thus there were three such flasks for the experiments with liver extract, three for muscle extract, and so on. Into each of the three liver flasks was then delivered 1 c.c. of liver extract. One of these — lettered *a* — was immediately mixed with an equal volume of 60 per cent KOH and placed on the boiling water bath so as to destroy the ferment. The other two flasks — lettered respectively *b* and *c* — after shaking, were placed in an incubator at 40° C. and incubated for a certain period of time, at the end of which a volume of 60 per cent KOH solution, equal to that of the contents of each flask, was added and the flask placed on the boiling water bath. The same procedure was followed in the case of the other extracts. The glycogen content of each solution was then determined by Pflüger's method, and, by subtracting the amount found in flasks B and C from that found in flask A, the amount of glycogen which had disappeared by incubation for a certain time was determined. For comparative purposes the result was also calculated as a percentage of the original amount of glycogen.

In all we have done four such experiments. In one of these the incubation was allowed to proceed for sixteen hours forty-five minutes under toluol, and it was found that by so long an incubation no glycogen was left in any of the preparations. The experiment was repeated with the same extracts (meanwhile kept in the ice box under toluol) three days later, with the difference that incubation lasted only three hours. It was found that all the glycogen had disappeared from each preparation

except in the case of the muscle extract. The control in this case contained 0.0929 gm. glycogen, the incubated specimens an average of 0.0785 gm. The amount which had disappeared was therefore 0.0144 gm., or 15.5 per cent of the original amount.<sup>29</sup>

In the subjoined table are given the results of three experiments conducted as above described, and in which one flask of each extract was incubated for a period somewhat less than that required to cause disappearance of the starch reaction in the preliminary experiment with 0.5 c.c. of the extracts, and the other for a period somewhat greater than this.

In all three experiments the extract of pancreas was by far the strongest in glycogenase. Even although this extract was diluted from ten to fifty times with water, 1 c.c. of it caused the entire disappearance of glycogen in all the tests made, the shortest period being one hour. Next in strength came the liver extract and the blood serum.

In the first two of the above experiments the liver extract was distinctly stronger than the blood serum, but these and one other reported below are the only experiments of a long series, in which the two have been compared, that such a result was obtained. In all the others the blood serum proved stronger than the liver extract. We can offer no explanation of the cause of this exceptional result in the above experiments, although one point is perhaps worthy of record, viz., that the blood in both experiments behaved peculiarly in its clotting, for, even after standing for some two hours, the clot was not of its usual firm, shrunken nature, but was broken up and fragile, and a great proportion of the erythrocytes were not entangled in it but were floating free in the serum. It was therefore necessary to centrifuge this serum prior to using it for the above experiments. Another point of difference between this and the

<sup>29</sup> This experience led us in subsequent experiments to make a preliminary test of the strength of extracts with 0.5 per cent solution of soluble starch (Merck). For this purpose 10 c.c. of the starch solution were placed in a series of test tubes to each of which were then added amounts of extract ranging from 0.1 to 1 c.c. At the end of every half-hour some of the test tubes were removed from the incubator, the tube filled up with water, and 0.5 c.c. of N/10 iodine solution added. In this way it was found how long a period of incubation was necessary to cause disappearance of the starch blue reaction with 0.5 c.c. of extract, and this time was chosen as approximately the proper one during which to incubate the glycogen preparations. By employing varying amounts of each extract in these starch experiments, we were also able to form an idea as to their order of strength.

TABLE II.  
THE RELATIVE AMOUNT OF GLYCOGENASE IN SERUM AND IN BUCHNER EXTRACTS OF VARIOUS BLOOD-FREE ORGANS OF THE DOG.

Letter of experiment.	Source of extract (Buchner extract unless otherwise stated).	Amount of extract used.	Amount of one per cent glycogen solution used.	Amount of glycogen in flask <i>a</i> , <i>i. e.</i> before incubation.	Amount of glycogen in flasks <i>b</i> and <i>c</i> , <i>i. e.</i> after incubation.	Amount of glycogen disappeared.	Amount of glycogen disappeared in per cent of original amount.	Length of time of incubation.	Remarks.
J	Pancreas (1 in 10 saline extract)	1	20	(0.1500)	(b) none	all	100	2	.....
					(c) none	all	100	4	.....
	Liver	0.5	20	0.1372	(b) 0.010	0.1272	92.5	2	.....
					(c) none	all	100.0	4	.....
	Intestine	1	10	0.0519	(b) 0.0471	0.0048	9.2	2	.....
					(c) 0.0240	0.0279	53.7	4	.....
	Kidney (extract diluted 10 times with water)	1	20	0.1262?	(b) 0.1411	none	0	2	.....
					(c) 0.1383	none	0	4	.....
	Muscle	1	20	0.1535	(b) 0.1258	0.0277	18	2	.....
					(c) 0.1065	0.0470	30	4	.....
	Serum	1	20	0.1534	(b) 0.0874	0.0660	39.5	2	.....
					(c) 0.0625	0.0909	59.2	4	.....
	Pancreas (1 in 8 saline extract)	1	20	0.1445	(b) none	all	100	1½	.....
					(c) none	all	100	4	.....

M	Liver . . . . .	1	20	0.2059	(c) 0.02331	0.1826	88.6	4	1 Pavytation.	
	Kidney . . . . .	1	20	0.1162	(b) . . . . .	. . . . .	. . . . .	1½	. . . . .	
	Muscle . . . . .	1	20	0.1406	(c) 0.0594	0.0568	48.9	4	. . . . .	
	Serum . . . . .	1	20	0.1646	(b) 0.1485	none	0	1½	. . . . .	
	R	Kidney extract with 2 vols. H <sub>2</sub> O . . . . .	2	20	0.3123	(c) 0.1446	none	0	4	. . . . .
			2	20	0.2190	(b) 0.0908	0.0738	44.7	1½	. . . . .
			2	20	0.2341	(c) 0.0271	0.1375	83.3	4	The corresponding percentages for blood serum were 57.4 (2 hrs.) and 78.0 (serum); for liver they were 7.2 (2 hrs.) See Table III.
			2	20	0.2262	(b) 0.1893	0.1230	39.3	. . . . .	
			2	20	0.2262	(c) 0.1669	0.1454	46.5	. . . . .	
	2	20	0.2341	(b, c) none	all	100	1			
2	20	0.2262	(b) 0.2113	0.0228	9.4	4				
I	Pancreas (1-50 saline)	2	20	0.2262	(c) 0.2127	0.0214	6.0	4	. . . . .	
		2	20	0.2262	(b) 0.2210	0.0052	4.7	4	. . . . .	
		2	20	0.2262	(c) 0.2140	0.0122	11.7	4	. . . . .	
		2	20	0.2262	(b) 0.2145	0.0117	30.8	4	. . . . .	
I	Submaxillary gland (1-1 saline)	2	20	0.2190	(c) 0.2175	0.0097	11.7	4	. . . . .	
		2	20	0.2190	(b) 0.2046	0.0144	11.7	4	. . . . .	
I	Serum . . . . .	1	20	0.2301	(c) 0.1818	0.0372	11.7	4	. . . . .	
		1	20	0.2301	(b) 0.1775	0.0526	30.8	4	. . . . .	
1	20	0.2301	(c) 0.1409	0.0892	30.8	4	. . . . .			

experiments to be hereafter described is that the liver was not washed free of blood by a cannula in the portal vein, but by one inserted through the descending aorta. In all the other experiments the cannula was in the portal vein. It is interesting to note that Bang, Ljungdahl, and Bohm,<sup>30</sup> working on rabbits, found when they perfused sodium chloride solutions through the entire animal just prior to death, that the glycogenolytic activity of the liver pulp was distinctly greater than when no such perfusion had been practised. They ascribe this increase in ferment to asphyxia. Such cannot, however, be the explanation in the last mentioned of our experiments; it is more probable that the result is due to the transference by the saline solution to the liver of an excess of ferment from the pancreas.

The extracts of muscle and kidney were in the first two experiments much feebler than any of the others. The kidney extract (J) had to be diluted with water ten times in order to yield a sufficient amount of fluid with which to conduct the observation; at which dilution it caused no measurable glycogenolysis in four hours. In the other experiment (M) an undiluted extract of kidney caused about 50 per cent of the glycogen to disappear. In experiment R the kidney extract was stronger than that of liver, but feebler than blood serum.

The extract of muscle was inactive in one experiment (M) and showed only feeble power in another (J). A muscle extract was also prepared in the course of Experiment I (see p. 266), in which case it caused 15.5 per cent of the glycogen to disappear in three hours, whereas the liver extract, blood serum, and intestine extract in this experiment caused in the same time a total disappearance of glycogen. The extract of intestine seems to be of about the same glycogenolytic strength as that of the kidneys.

In order of strength of glycogenolytic ferment, we can therefore place the pancreas first, then the liver and blood serum, then the kidney and intestine, and, last of all, the muscle. Wohlgemuth and Benzur,<sup>31</sup> working on rabbits, found the serum by far the strongest in amylolytic action, then, in order, the kidney, the muscles, and the liver. This apparent discrepancy with our results may be due to the fact that a different animal was used. We do not, of course, know whether this overwhelmingly greater glycogenolytic strength of the pancreatic extracts

<sup>30</sup> BANG, LJUNGDAHL, and BOHM: *Loc. cit.*

<sup>31</sup> WOHLGEMUTH and BENZUR: *Biochemische Zeitschrift*, 1909, xxi, p. 460.

indicates that this gland is the site of production of glycogenase in the animal body, for a natural secretion of the gland is very strong in diastatic ferment, and it may merely be the unsecreted store of this in the gland cells, which these extracts contain. If the pancreatic cells are the source of the tissue diastases, then they must secrete such ferment in both directions, *i. e.*, into the duct and into the blood or lymph; or it may be that the diastase which is secreted into the duct is of a somewhat different nature from that which is delivered into the blood and lymph, the former being especially active towards starch and the latter towards glycogen. Investigations into the possibility of such a difference in the diastases of pancreatic juice and pancreatic extract are in progress in this laboratory and will be reported in the near future.

#### THE RELATIVE GLYCOGENOLYTIC POWER OF SERUM AND LIVER IN THE DOG.

In the present investigation we have paid more particular attention to the relative glycogenolytic strengths of the liver and blood serum, for, since in the intact animal the most active glycogenolysis undoubtedly occurs in the liver, it is important to know whether this is brought about by a ferment manufactured in that organ itself, or by a ferment carried to it from some other source by means of the blood or lymph. We have accordingly made numerous experiments in which the glycogenolytic strength of blood serum and Buchner extract of liver were compared. A large number of observations were necessary because of the contradictory results which we obtained in Experiments J and M.

The experiments were conducted in the manner above described, and in every case, unless otherwise stated, a Buchner extract of liver was employed. For reasons which will be explained in the discussion of results, some of the liver extracts were rendered faintly alkaline before incubation and were kept faintly alkaline during it. In other cases, instead of using serum itself, serum after contact with infusorial earth was employed. The results are contained in Table III.

Of the thirteen experiments quoted in the above table there was only one (O) in which the Buchner extract of liver proved itself to contain more glycogenase than an equal volume of blood serum. This gives three experiments in all in which such a result was obtained (*cf.* p. 268).

TABLE III.  
THE RELATIVE AMOUNT OF GLYCOGENASE IN SERUM AND IN BUCHNER EXTRACTS OF BLOOD-FREE LIVER.

Letter of expt.	Source of extract.	Amount of extract used.	c.c.	Amount of one per cent glycogen solution used.	e.c.	Amount of glycogen in flask <i>a</i> , <i>i. e.</i> before incubation.	gm.	Amount of glycogen in flasks <i>b</i> and <i>c</i> , <i>i. e.</i> after incubation.	gm.	Amount of glycogen dispersed.	gm.	Amount of glycogen dispersed in per cent of original amount.	Length of time of incubation.	Remarks.
C	Liver	2.5	10 <sup>1</sup>	0	0	0	0	0	0	0	0	0	16½	1 About 2 per cent solution. No Na <sub>2</sub> CO <sub>3</sub> added.
D	Liver	2	20	0.1075	0.1075	0.0263	0.0812	0.0257	0.0818	7.6	7.6	16½	Made faintly alkaline with Na <sub>2</sub> CO <sub>3</sub> .	
	Serum (after mixing with infusorial earth)	2	20	0.0680	0.0680	none	all	none	all	100	100	16½	Serum very milky.	
E	Liver <sup>2</sup>	2	20 <sup>1</sup>	0.2690	0.2690	(b) 0.1200 (c) 0.1416	0.1490 0.1274	0.1416	0.1490 0.1274	55.1 47.1	55.1 47.1	16 16	<sup>2</sup> Blood not washed out of liver.	
	Serum	2	20 <sup>1</sup>	0.2444	0.2444	(b) 0.0976 (c) 0.0916	0.1468 0.1428	0.0916	0.1468 0.1428	60 58.4	60 58.4	16 16	Reaction of liver extract made faintly alkaline with Na <sub>2</sub> CO <sub>3</sub> .	
F	Liver	2	20	0.1457	0.1457	(b) 0.0991 (c) 0.0911	0.0466 0.0546	0.0991	0.0466 0.0546	31.9 37.3	31.9 37.3	3½ 3½	Reaction of digest kept faintly alkaline with Na <sub>2</sub> CO <sub>3</sub> .	
	Liver	2	20	0.1457	0.1457	(b) 0.0795 (c) 0.1160	0.0662 0.0297	0.0795 0.1160	0.0662 0.0297	45.3 20.3	45.3 20.3	3½ 3½	No Na <sub>2</sub> CO <sub>3</sub> added to digest.	
G	Serum (after mixing with infusorial earth)	2	20	0.1120	0.1120	(b) none (c) none	all all	none none	all all	100 100	100 100	3½ 3½	Reaction of digest faintly alkaline throughout.	
	Liver	1	20	0.1596	0.1596	(b) none (c) none	all all	none none	all all	100 100	100 100	5½ 5½	Bld washed out with water instead of 0.9 NaCl sol.	
O	Serum (carotid)	1	20	0.1143	0.1143	(b) 0.0713 (c) 0.0312	0.0430 0.0831	0.0713 0.0312	0.0430 0.0831	37.7 72.8	37.7 72.8	1½ 1½	Dog refused food for some days before expt.	
	Serum pancreatico-duodenal vein	1	20	0.1143	0.1143	(b) 0.0776 (c) 0.0390	0.0367 0.0753	0.0776 0.0390	0.0367 0.0753	32.2 66.0	32.2 66.0	1½ 5½	.....	



P (I)	Liver	1	20	0.1291	(b) 0.0910	0.0381	30	2	Dog specially fed for 3 days.
	Serum	1	20	0.0962	(c) 0.0540 (b) 0.0655	0.0751 all	58.2 31.9	5	
P (II)	Liver	1	20	0.0881	(c) none (b) 0.0418	0.0463	52.5	5	Dog starved for 3 days. S'r'm cont'd many erythrocytes, dry subs. = 8.6%. Serum very clear, dry subs. = 8.1 per cent. Liver washed out through aorta.
	Serum	1	20	0.1068	(c) 0.0539 (b) 0.0796	0.0272	25.5	2	
	A. centrifuged	1	20	0.1016	(c) 0.0122 (b) 0.0303	0.0946	88.5	5	
	B. centrifuged	1	20	0.2754	(c) 0.1110 (b) 0.2556	0.0713	70.5	2	
R	A. Liver	1	20	0.1016	(c) 0.0906 (b) 0.198	0.0906	89.1	5	Serum still opalescent.
	B. Water extract of "presscake"	1	20	0.2754	(c) 0.2556 (b) 0.6152	0.0198	7.2	2	
	Serum	1	20	Cu <sub>2</sub> O 0.5806	(c) 0.5776	none	.....	4	
	A. centrifuged	1	20	0.2386	(b) 0.0666 (c) 0.1009	0.1720 0.1345	72 57.4	4	
S (I)	B. uncentrifuged	1	20	0.2354	(b) 0.1009 (c) 0.0517	0.1837	78.0	4	.....
	Liver (starved)	1	20	0.1101	(b) 0.0615 (b) trace	0.0486	44.1	2(?)	
S (II)	Serum (starved)	1	20	0.0996	(b) trace (c) trace	practically all	practically 100	2	.....
	Liver (ordinarily fed)	1	20	0.1299	(b) 0.0929 (c) 0.0930	0.0369	28.4	2	
T	Serum	1	20	0.0898	(c) trace (b) 0.1078	practically all	practically 100	2	Canvas soaked in 0.9 NaCl before enclosing liver, etc. in it.
	Liver	1	20	0.1885	(c) 0.0587	0.0807	42.8	3	
W	Serum	2	20	0.1623	(c) 0.0587	0.1036	63.8	3	.....
	Liver	2	20	0.1931	(b) 0.1727 (c) 0.1439	0.0204 0.0492	10.5 25.4	2	
Z	B. extract and equal volume 0.9 NaCl.	2	20	0.1870	(c) 0.0695 (c) 0.0481	0.1175 0.1389	63.0 74.0	.....	.....
	Serum	2	20	0.1231	(b) 0.1010 (c) 0.0924	0.0221 0.0307	17.9 24.9	2	
Z	Liver (B. extract and equal vol. 0.9 NaCl.	1	20	0.1254	(c) 0.0447 (c) 0.0200	0.0807 0.1054	64.5 84.3	2	.....
	Serum	1	20	0.1254	(c) 0.0200	0.1054	84.3	4	

This experiment was in many respects a peculiar one. It was on a dog that had refused food for some days prior to the experiment, and its primary object was to compare the amount of glycogenase in blood serum from the pancreatico-duodenal vein with that from the carotid. It was found that, if anything, the serum from the carotid was the stronger. The dog was then bled to death and the pancreas removed, after which a cannula was placed in the portal vein and 0.9 per cent sodium chloride solution transfused. The liver would not, however, wash free of blood, so the cannula was connected with a water faucet and the perfusion conducted under pressure. The extract of pancreas caused no glycogenolysis even after five hours' incubation, and the liver extract was so strong that in a little over an hour's incubation 1 c.c. of it caused 0.16 gm. glycogen to disappear. At first we thought that the perfusion with water instead of with saline had caused plasmolysis of the liver cells, with consequent disruption of the ferment, and that this accounted for the great strength of the extract. A subsequent experiment was therefore performed in which one half of the liver was washed with isotonic serum and the other half with tap water. Extracts of the two halves showed, however, no difference in glycogenase, as the following results testify:

- A. 5 c.c. isotonic saline extract of liver washed with saline; plus 20 c.c. glycogen solution gave 0.1280 gm. glycogen-dextrose.  
The same after incubation for five hours gave 0.0865 gm.  
Amount disappeared, 0.0415 gm.
- B. 5 c.c. water extract of liver washed with water; plus 20 c.c. glycogen solution gave 0.1270 gm. glycogen dextrose.  
The same after incubation for five hours gave 0.0911 gm.  
Amount disappeared, 0.0359 gm.

Before concluding that the serum is really stronger in glycogenase than the liver, there are several possible sources of fallacy which must be considered. Those which seemed to us of importance are as follows:

1. The possibility of *adsorption of the glycogenase* by infusorial earth in the case of liver extracts prepared by Buchner's process. That infusorial earth can adsorb ferments has been shown by Hedin for *a* protease, and although it has not been shown specifically for diastatic ferments, yet it is probable that with these also such a process takes place. To ascertain whether this might be the cause of the above differences, we have in two of the experiments (*viz.*, B and F) thoroughly mixed blood serum with infusorial earth in the same proportion as that em-

ployed in making the liver extracts, then enclosed the resulting paste in canvas and placed in the Buchner press. The resulting extract (*sic*) was in both experiments found to be several times stronger than the corresponding liver extracts. In another experiment not reported in the above table, we compared the glycogenolytic strength of a regular Buchner extract with that of one in which no infusorial earth, but only quartz sand, was used in preparing the liver. It was found that the extract prepared with infusorial earth contained 17.29 per cent solids and caused 45.5 per cent glycogenolysis in six hours. The extract prepared with sand alone contained 21.58 per cent solids and caused 39.1 per cent of glycogenolysis.

Malt diastase is readily adsorbed by blood fibrin (*cf.* Vernon, p. 160), so that it is possible that plasma might have a greater glycogenolytic power than the serum of the same blood. In consideration of this possibility we have compared the glycogenolytic strength of 1 c.c. serum with that of 1.2 c.c. of plasma obtained by centrifuging blood that had been mixed with 2 per cent oxalate solution in the proportion of one part oxalate solution to five parts blood. Both caused 27 per cent glycogenolysis in four hours' incubation.

Wohlgemuth<sup>32</sup> has also found that serum and (hirudin) plasma have the same amylolytic strength.

2. *The difference in reaction of the liver extract and blood serum, the former being invariably acid towards litmus, the latter alkaline.* In Experiments D, E, and F, a sufficient amount of a weak (1 per cent) solution of sodium carbonate was added to the liver extract to render it distinctly alkaline towards litmus. On comparing the glycogenolytic strength of this alkaline extract with that of the same extract left in its original reaction, no essential difference was found in the results (Experiments D and F), although the duplicates in Experiment F were unusually inconstant. In all three observations the serum proved itself to be markedly stronger than the liver extract. During incubation the acidity of the liver extract increases, that is to say, an extract made alkaline towards litmus to start with will, on incubation, become acid again. On this account, in Experiment F, the alkali was added not only at the beginning of the experiment, but at the end of every half-hour throughout it, so that the mixture of glycogen solution and extract, as well as that of glycogen solution and serum, was kept very faintly

<sup>32</sup> WOHLGEMUTH: *Biochemische Zeitschrift*, 1000, xxi, p. 381.

alkaline towards litmus throughout incubation. It was found, as in the previous experiments, that the serum was much more active than the liver extract.

#### THE INFLUENCE OF REACTION ON THE GLYCOGENOLYTIC ACTIVITIES OF SERUM AND LIVER EXTRACT.

These observations do not, however, finally dispose of the criticism that the differences above observed are due to the reaction. To further investigate the question, it was necessary for us to study the influence on the glycogenolytic strengths of liver extract and blood serum of different degrees of acidity and alkalinity. The following table (IV) depicts the result of such an experiment, the general plan and procedure of which were as above described.

It will be seen that the addition of a very small amount of acid to serum (0.2 c.c. of 0.78 per cent acid to 20 c.c. glycogen solution) increased the action of the ferment; that three times as much acid as this (0.6 c.c.) brought back the activity to the normal degree, and that five times (1.0 c.c.) this amount inhibited the action entirely (*i. e.*, when the solution contained 0.039 per cent of glacial acetic acid, or 0.13 N acid). On liver extracts, on the other hand, corresponding additions of acid had from the start a depressing influence.

The effect of the above-mentioned quantities of a practically 1 per cent solution of sodium carbonate to serum caused from the start a marked depression of the glycogenolytic action, but their addition to liver extract (as shown in Experiment *a*) caused little depression until a considerable amount (1 c.c. of 0.954 per cent solution) of alkali had been added. The acids produced in the liver extract had evidently neutralized the smaller additions of added alkali. This result on the effect of alkali on liver extracts explains why in Experiments E and F (Table III) the addition of small amounts of alkali did not have any appreciable effect on the activity of the preparations.

These results are exactly the same as those obtained by Chittenden,<sup>33</sup> Detmer,<sup>34</sup> Kjeldahl,<sup>35</sup> Schierbeck,<sup>36</sup> etc., relative to the effect of very

<sup>33</sup> CHITTENDEN and GRISWOLD: American chemical journal, 1881, iii, p. 305; CHITTENDEN and ELY: *Ibid.*, 1882, iv, p. 107.

<sup>34</sup> DETMER, W.: Zeitschrift für physiologische Chemie, 1883, vii, p. 1.

<sup>35</sup> KJELDAHL, *vide* SCHIERBECK: *Loc. cit.*

<sup>36</sup> SCHIERBECK: Skandinavisches Archiv für Physiologie, 1892, iii, p. 334.

small additions of acid or alkali on the hydrolysis of starch solutions by means of malt diastase, saliva, or pancreatic juice. Briefly stated, these results were that a small amount of acid accelerates the hydrolysis when the reaction to start with is faintly alkaline or neutral, but depresses it when the initial reaction is already faintly acid. The addition of the minutest trace of alkali to a digest of which the original reaction is faintly alkaline has, on the other hand, a marked depressing effect. Schierbeck also studied the effect of the addition of a very weak acid (CO<sub>2</sub>) to a mixture of saliva and glycogen solution and found it to be accelerating. Bial<sup>37</sup> also found that the addition of a small amount of N/10 sulphuric acid to serum increased its diastatic action, but that more than this caused a depression. The lactic acid produced by autolytic processes in the liver extract would therefore be expected to have, at the dilution of 1 in 20, as is the case in the above experiments, an accelerating, rather than a depressing influence on the glycogenolytic activity of these, and its development cannot probably be held responsible for the relatively feeble glycogenolysis exhibited by the liver extracts.

#### VARIATIONS IN THE GLYCOGENOLYTIC POWER OF BLOOD SERUM AND OF LIVER IN THE DOG.

When we compare the results obtained in all of the observations here recorded, we are struck with the fact that although the serum is nearly always stronger in glycogenase than the liver extract, both of these show considerable variations of strength in different dogs; thus, taking the results *with 1 c.c. serum*, we obtain in 2 hours or less the following percentile glycogenolysis:

37.7 (O); 31.9 (P 1); 25.2 (P. 2); 57.4 (R); 100 (S 1); 100 (S 2); 63.0 (W 2 c.c. serum); 64.5 (X). *Average* (excluding S 2 and W), 52.8. In from two to five hours the corresponding values were: 100 (F 2 c.c.); 72.8 (O); 100 (P 1); 88.5 (P 2); 78 (R); 63.8 (T); 74 (W 2 c.c.); 84.3 (X). *Average* (excluding F and W) 81.2.

It will be noted that results obtained by four hours' incubation are tolerably constant, much more so than those obtained after shorter incubation. Indeed, the only value which, in the latter group of observations, digresses markedly from the average of the others is P 1, to which

<sup>37</sup> BIAL: *Loc. cit.*

TABLE IV.  
EFFECT OF REACTION ON GLYCOGENOLYTIC STRENGTH OF SERUM AND LIVER EXTRACT.<sup>1</sup>

Experiments.	Degree of acidity or alkalinity.	Incubation time.	Amount of glycogen after incubation.	Amount of glycogen disappeared.	Amount glycogen disappeared in per cent of original amount.		Reaction to litmus.		Remarks.
					gm.	gm.	per cent	per cent	
T Serum	.....	hr. Boiled	0.1623	.....	.....	.....	.....	.....	5 c.c. of the 1% acetic acid used = 6.5 c.c. n/10 alkalisothat instead of being 1%, the acid solution was 0.78%.
	Original reaction	3	0.0587	0.1036	63.8	.....	.....	.....	
	0.2 c.c. 1% HA (= 0.0078% glacial acid	3	0.0366	0.1257	77.4	neutral	neutral	neutral	
	0.6 cc. 1% HA (= 0.0224% glacial acid	3	0.0551	0.1072	66.0	faintly acid	faintly acid	neutral	
	1.0 c.c. 1% HA 0.0390% glacial acid	3	0.1627	none	0	faintly acid	faintly acid	fairly acid	
	.....	Boiled	0.1885	.....	.....	.....	.....	.....	
T Liver extract	Original reaction	3	0.1078	0.0807	42.8	neutral	neutral	neutral	.....
	0.2 c.c. 1% HA = 0.0078% glacial acid	3	0.1444	0.0441	23.3	acid	acid	acid	.....
	0.6 c.c. 1% HA 0.0224% glacial acid	3	0.1375	0.0510	27.0	acid	acid	acid	.....
	1.0 c.c. 0.039% acid	3	0.1679	0.0106	5.6	acid	acid	acid	.....

T Serum	0.2 c.c. 1 % Na <sub>2</sub> CO <sub>3</sub> . . .	3	0.1162	0.0461	28.4	alkaline	alkaline	5 c.c. of the 1 % Na <sub>2</sub> CO <sub>3</sub> solution used equalled 9.0 c.c. n/10 alkali, so that solution was really 0.954 %.
	0.6 c.c. 1 % Na <sub>2</sub> CO <sub>3</sub> . . .	3	0.1654	none	0	alkaline	alkaline	
	1.0 c.c. 1 % Na <sub>2</sub> CO <sub>3</sub> . . .	3	0.1611	none	0	alkaline	alkaline	
T Liver extract	0.2 c.c. 1 % Na <sub>2</sub> CO <sub>3</sub> . . .	3	0.1644	....	....	f'tly alk.?	f'tly acid?	
	0.6 c.c. 1 % Na <sub>2</sub> CO <sub>3</sub> . . .	3	0.1503?	....	....	alkaline	alkaline	
	1.0 c.c. 1 % Na <sub>2</sub> CO <sub>3</sub> . . .	3	lost	....	....	alkaline	....	
	.....	Boiled	0.1085	....	....	....	....	
a Liver extract (2 c.c.)	Original reaction . . . . .	4	0.0767	0.0318	29.4	....	....	
	0.2 c.c. 1 % Na <sub>2</sub> CO <sub>3</sub> . . .	4	0.0781	0.0304	28.1	....	....	
	0.4 c.c. 1 % Na <sub>2</sub> CO <sub>3</sub> . . .	4	0.0830	0.0255	23.6	....	....	
	0.6 c.c. 1 % Na <sub>2</sub> CO <sub>3</sub> . . .	4	0.0816	0.0269	24.9	....	....	
	1.0 c.c. 1 % Na <sub>2</sub> CO <sub>3</sub> . . .	4	0.0987	0.0098	9.0	....	....	
	.....	Boiled	0.1019	....	....	....	....	
a Serum	Original reaction . . . . .	4	0.0744	0.0275	26.9	....	....	
	0.2 c.c. 1 % Na <sub>2</sub> CO <sub>3</sub> . . .	4	0.0819	0.0200	19.6	....	....	
	0.4 c.c. 1 % Na <sub>2</sub> CO <sub>3</sub> . . .	4	0.0951	0.0068	6.6	....	....	
	0.6 c.c. 1 % Na <sub>2</sub> CO <sub>3</sub> . . .	4	0.0921	0.0098	9.6	....	....	

(20 c.c. glycogen solution and 1 c.c. of serum, *i. e.*, liver extract used in each case.)

the value of 100 is given. This is almost certainly too high, since traces of glycogen might well have been missed in the estimation.

Turning now to the results obtained with 1 c.c. of the liver extracts, we find in two hours or less: 100 (O); 30 (P 1); 52.5 (P 2); 7.2 (R); 44.1 (S 1); 28.4 (S 2); 10.5 (W); 17.9 (X). Average (excluding O, in which the liver was washed out with water), 27.2.

And for the longer period of incubation: 31.9 (F 2 c.c.); 58.2 (P 1); 42.8 (I); 25.4 (W); 24.9 (X). Average (excluding F), 37.8. The greater inconstancy of results with liver extract, as compared with those with blood serum, is to be expected, for it is impossible to be certain that in every case the conditions regarding the reaction and concentration of the extract are the same. As already pointed out, we have endeavored to keep the concentration of the extracts constant by always following exactly the same procedure in their preparation, and we have controlled our results by making frequent dry-weight determinations. By this means we have found that the extracts were nearly constant with regard to solids.

Another possible cause of irregularity in the above results is a varying purity of the glycogen solutions used. The glycogen for the experiments was prepared by Pflüger's process.

The crude glycogen, obtained by adding alcohol to the diluted alkaline extract, was dissolved in water, the resulting alkaline solution exactly neutralized towards litmus, the glycogen then reprecipitated with alcohol, this glycogen precipitate washed repeatedly with alcohol followed by ether and then dried; or, in several cases, the second precipitate was again redissolved in water and precipitated a third time. The 1 per cent glycogen solution used for the above experiments was made in distilled water and was in every case perfectly neutral in reaction towards litmus and lacmoid. It is, however, possible that these glycogen solutions were not always of exactly the same composition; they may have varied very slightly in reaction, too slightly to be observed by litmus and lacmoid, and they may have varied in their relative amounts of dextrines which they contained, for, by Pflüger's process, the higher dextrines are undoubtedly precipitated along with glycogen.

In consideration of these possible sources of error, we have been careful to use the same glycogen preparations for all comparative experiments. Even admitting these possible sources of error, *it is plain*



that the serum is of greater glycogenolytic strength than an equal volume of liver extract.

Although differences in strength of the liver extracts may be due, not only to real variations in the amount of glycogenolytic ferment in the liver cells, but also to uncontrollable variations in the method of their preparation and probably in their reaction, the differences observed in the case of blood serum can be due to one cause only, viz., to a variable amount of glycogenolytic ferment. We have attempted to ascertain the cause for this variability, but with little success. One or two points are, however, worthy of mention. It was noted that the very strong sera were invariably highly opalescent, whereas the feeble sera were clear, and, as already mentioned in two cases (Experiments J and M), were obtained by centrifuging blood which had not clotted properly. This observation led us to see what influence the nutritive condition of the dog might have on the glycogenolytic strength of the serum. In Experiment P 1 the dog was starved for three days prior to that of the experiment, and in P 2 the dog was liberally fed for the same period. The serum of the well-fed dog hydrolyzed all the glycogen in five hours and that of the starved dog caused about 90 per cent to disappear. For reasons already set forth, it would be rash to conclude from these figures that the two sera differed from one another in glycogenolytic power. An observation of the same nature as that just described was repeated in Experiments S 1 and S 2 with the same result, both sera causing complete glycogenolysis in two hours. These experiments on the effect of feeding were always conducted on the same glycogen solutions, so that all possible sources of error from varying conditions (of reaction, etc.) of the glycogen solutions might be avoided. We may conclude, therefore, that the state of digestion of the dog has no striking influence on the glycogenolytic strength of the blood. Wohlgemuth<sup>38</sup> has also found that the amyolytic power of the blood serum of the dog is uninfluenced by starvation, nor could any variations be brought about by changes in the nature of the diet.

Turning now to the effect of nutrition on the liver extracts, it would appear from our results (Experiments P and S) that starvation causes the glycogenolytic strength of these to become somewhat greater. Bang and his co-workers<sup>39</sup> also found in the case of the rabbit that fasting

<sup>38</sup> WOHLGEMUTH: *Biochemische Zeitschrift*, 1909, xxi, p. 381.

<sup>39</sup> BANG, LJUNGBAHL, and BOHM: *Loc. cit.*

causes a moderate increase in the glycogenolytic ferment of the liver. It is conceivable that this difference is due to the greater dilution of the liver extract of the well-fed dog by substances such as glycogen, fat, etc., deposited in the liver cells. Dry-weight estimations of the two extracts did not throw any light on this question, for they came out the same; but that might well be and yet the concentration of actual cell juice in the extracts be different. In any case the difference is slight and probably of no consequence.

#### THE RELATIVE GLYCOGENOLYTIC POWER OF THE LIVER AND SERUM IN THE SHEEP, PIG, AND RABBIT.

Further to control the results above reported, we have conducted observations, similar to the above, on the glycogenolytic powers of the blood serum and liver extracts of other animals than the dog. We have chosen for this purpose the pig, the sheep, and the rabbit. The pig and the sheep were not nearly full grown, but the rabbits were. In all cases the liver was washed free of every trace of blood with 0.9 per cent sodium chloride solution, and Buchner extracts prepared exactly as described above were employed. The extract of the lamb's liver did not contain the usual (18) per cent of solids; it contained only 10.9 per cent. The extract of the pig's liver contained 17.3 per cent of solid matter. No estimation was made of the dry substance in the case of the rabbit's liver extract. Table V gives the results of these experiments.

These observations furnish results regarding the relative strength of serum and liver which are in line with those obtained in the case of the dog. The only apparent exception occurred in the case of the lamb where the liver extract gave, in one of the observations, a glycogenolysis amounting to 19.6 per cent in four hours, and the serum only 5.7 per cent. In the other observations on this animal, however, neither serum nor extract gave any glycogenolysis whatsoever. What this very feeble glycogenolytic power in the liver and serum of the lamb can signify, we are unprepared to say. The lamb was fairly well grown and must have been for some time on grass. There was a distinct amount of glycogen in the liver extract, for whereas 20 c.c. of the 2 per cent glycogen solution employed gave when inverted 0.1515 gm. dextrose, the same amount of the same glycogen solution with 2 c.c. of liver extract added

to it gave, after treatment with potassium hydroxide, precipitation with alcohol and inversion, 0.1848 gm. dextrose, *i. e.*, 1.665 per cent glycogen in the extract.

Next in strength came the preparations from the rabbit, of which the serum was very much stronger than the liver extract. The result taken along with that of the lamb's liver shows us that the amount of glyco-  
genolytic ferment in an organ bears no relationship to the amount of glycogen which that organ contains. The preparations from the pig were the strongest of all, being about the same, in this regard, as the average for the dog, with the serum markedly stronger than the liver. There was an unusually large amount of glycogen in the liver of this animal.

So far as these few experiments go, we may state that the largest amounts of glyco-  
genolytic ferment are contained in the tissues of the dog and pig, next largest in the rabbit, and least of all in the lamb. It would appear that the omnivorous pig and dog have more glyco-  
genolytic ferment in their tissues than the herbivorous rabbit and lamb; but whether this difference between the two groups of animals will be borne out by experiments on other animals of the two groups, remains to be seen. Similar results to the above have been obtained by Noel Paton<sup>40</sup> and Schlesinger.<sup>41</sup> The former using dried alcohol precipitates of liver found that no glyco-  
genolysis occurred with preparations from the rabbit and sheep, but that it was marked in similar preparations from the dog and cat. The latter found that the serum of the dog was much more active than that of the rabbit and ox. Bang, Ljungdahl, and Bohm<sup>42</sup> found that the minced blood free liver of the rabbit caused, in four hours' incubation, a glyco-  
genolysis amounting, on an average, to 9.4 per cent for summer rabbits. Considering that in these experiments no means were taken to liberate the endo-enzymes from the liver cells, this result is about the same as ours, which were also obtained on summer rabbits. Bang, etc., also found blood serum to be very much more active than liver (average per cent of glyco-  
genolysis in six rabbits, 23 per cent), but the serum and liver did not vary parallel with one another, the serum sometimes being very strong and the liver very weak in the same animal. This obser-

<sup>40</sup> NOEL PATON: The journal of physiology, 1897, xxii, p. 121.

<sup>41</sup> SCHLESINGER: *Loc. cit.*

<sup>42</sup> BANG, LJUNGD AHL, and BOHM: *Loc. cit.*

TABLE V.  
THE RELATIVE AMOUNTS OF GLYCOGENASE IN BLOOD SERUM AND LIVER EXTRACT OF THE SHEEP, PIG, AND RABBIT.

Letter of experiment.	Source of extract and animal.	Amount of glycogen in flask <i>a</i> .	Amount of glycogen in flasks <i>b</i> , <i>c</i> , and <i>d</i> , <i>i.e.</i> of the incubation	Amount of glycogen disappeared.	Amount of glycogen disappeared in per cent of original amount.	Time of incubation.	Remarks.
		gm.	gm.	gm.		hr.	
U	Lamb serum . .		<i>b</i> . 0.1950	none	none	1	
		....	<i>c</i> . 0.1883	none	none	2	
	Lamb liver . .		<i>d</i> . 0.1838	0.0112	5.7	4	.....
				<i>b</i> . 0.1705	0.0143	7.7	1
V	Lamb serum . .	0.1848	<i>c</i> . 0.1486	0.0362	19.6	2	
			<i>d</i> . 0.1484	0.0364	19.6	4	
	Lamb liver . .	0.1225	<i>b</i> . 0.1237	none	none	4	Same preparations used as in U after standing 4 days.
		0.1077	<i>b</i> . 0.1115	none	none	4	

U	Pig serum . . .	0.1352	b. 0.0672	0.0680	50	1	Same preparations as in U after standing 4 days.
			c. 0.0686(?)	....	....	2	
V	Pig liver . . .	0.2233	d. 0.0391	0.0961	71	4	.....
			c. 0.1944	0.0289	13	2	.....
V	Pig serum .	0.1326	d. 0.1362	0.0871	39	4	Same preparations as in U after standing 4 days.
			b. 0.0366	0.0960	72.3	4	
U	Rabbit serum .	0.1612	b. 0.0869	0.0453	34.2	4	Same preparations as in U after standing 4 days.
			b.	....	....	1	
U	Rabbit liver . .	0.1861	c. 0.0990	0.0622	38.5	2	Liver mass mixed with equal volume 0.9% NaCl solution.
			d. 0.0799	0.0813	50.4	4	
V	Rabbit liver . .	0.1274 (?)	b. 0.1586	0.0275	14.7	1	Same preparations as in U after standing 4 days.
			c. 0.1633	0.0228	12.2	2	
V	Rabbit serum .	0.1391	b. 0.0651	0.0740	53.1	4	Same preparations as in U after standing 4 days.
			b. 0.1242	none (?)	....	4	

1 In every case 2 c.c. serum or extract was mixed with 20 c.c. of a 1 per cent glycogen solution.

vation is also confirmed by ours on dogs. These workers see in this want of parallelism an argument for the independence of the hepatic and serum diastases.

Bial<sup>43</sup> also found that the blood of man immediately after birth is free from diastase; that of the adult is much stronger, but is less so than that of the rabbit and ox. Blood of the dog he found to be strongest of all, although pig blood is frequently of equal strength.

The undoubted variation in the amount of glycogenase in the serum and liver of different animals renders it impossible to use the results obtained on one animal as standards for comparison with another animal. For example, one cannot compare the glycogenolytic strength of the liver of a depancreated dog with that of the normal rabbit, as has been done by Bang, Ljungdahl, and Bohm.<sup>44</sup>

Loewi<sup>45</sup> found the blood serum of the dog to be much stronger in glycogenolytic ferment than the rabbit, and slightly more so than the guinea pig.

#### DISCUSSION OF RESULTS.

Although it is not our intention in the present paper to discuss at any length the significance of the above-recorded results in the metabolism of glycogen, we will, nevertheless, before concluding, consider them briefly in this connection, and compare them with those of previous workers. Before any marked advance can be hoped for in our knowledge of the rôle that the liver and other organs play in the metabolism of carbohydrates in the animal economy, it is evident that we must know with certainty in what portions of the body the greatest glycogenolytic activity resides, and whether this activity is the result of an endoenzyme, produced by the organ itself, or of an exoenzyme carried to it by the blood and lymph. In the latter case we must trace the seat of production of the enzyme in the animal. Regarding the relative diastatic power of the liver and blood serum, recent researches are on record by Bial,<sup>46</sup>

<sup>43</sup> BIAL, M.: *Archiv für die gesammte Physiologie*, 1893, liii, p. 156.

<sup>44</sup> BANG, LJUNGDÄHL, and BOHM: *Beiträge zur chemischen Physiologie und Pathologie*, 1907, ix, p. 408; 1907, x, p. 1; 1907, x, p. 312.

<sup>45</sup> LOEWI, OTTO: *Sitzungsberichte der Gesellschaft zur Beförderung der gesammten Wissenschaften (Marburg)*, 1904, p. 100.

<sup>46</sup> BIAL, M.: *Archiv für die gesammte Physiologie*, 1894, lv, p. 434.

Pick,<sup>47</sup> Pugliese and Domenichini,<sup>48</sup> Mendel and Saiki,<sup>49</sup> Schlesinger,<sup>50</sup> and Wohlgemuth and Benzur.<sup>51</sup> Bial, Schlesinger, and Wohlgemuth and Benzur found the blood serum stronger in diastatic ferment than the liver. The most exhaustive work in this connection is that of Bial, who believes that the diastatic action which blood-free liver exhibits, is due to the lymph which remains after all blood has been washed away by perfusion. He found the diastatic power of lymph and liver to run parallel with one another. He further showed that if a very inert liver, such as that of the rabbit, be mixed with dog blood, its diastatic power became greatly increased. In contradiction to these results, are those of Pick, who found in the dog that a saline extract of an alcohol precipitate of liver was stronger in glycogenase than serum or lymph, and of Mendel and Saiki, who found that a dried alcohol precipitate of liver of the 275 mm. embryo pig was stronger in glycogenase than the serum of the same animal.

The unsatisfactory state of our knowledge on this important question is well illustrated by these contradictory results. It is impossible, as some have done (*cf.* Bang, etc.), to deny the possibility that the liver under normal conditions may owe its diastatic power mainly to the blood and lymph which bathes its cells, and that, after removal of the blood, there may remain behind sufficient lymph to endow it with a distinct though much feebler action. Such is the view of Bial. On the other hand, although it must require much more thorough perfusion to remove all the lymph from the organ than is necessary to remove the blood, yet, if this perfusion be prolonged, the lymph must also become removed, after which, if Bial be right, the glycogenolytic power of the liver extract should become correspondingly diminished. But there is no evidence so far that such is the case. In all our experiments the liver vessels have been washed with very large quantities of 0.9 per cent sodium chloride solution, and as a rule the lobes have been actively massaged. In other cases water instead of saline solution has been used for washing out the vessels, but there could be noticed no particular weakness of glycogenolytic action in the extracts that were afterwards prepared. We are at present investigating the effect of very prolonged continuous perfusion of the liver on the glycogeno-

<sup>47</sup> PICK: *Loc. cit.*

<sup>48</sup> PUGLIESE and DOMENICHINI: *Loc. cit.*

<sup>49</sup> MENDEL and SAIKI: *Loc. cit.*

<sup>50</sup> SCHLESINGER: *Loc. cit.*

<sup>51</sup> WOHLGEMUTH and BENZUR: *Biochemische Zeitschrift*, 1909, xxi, p. 460.

lytic power of its extracts, with the object of seeing whether results like those obtained by Vernon<sup>52</sup> in the case of the erepsin of the kidney will be obtained. This author found that when the organ was perfused with an antiseptic solution (2 per cent solution sodium fluoride) there was very little of the endo-enzyme removed during several days, but that if anything occurred which might cause disintegration of the cells the enzyme immediately became loosened and was removed by the perfusing fluid. We do not believe that the diastatic power which is left after thorough perfusion of the liver is due to lymph, and, in support of this insertion, we append the following experiment:

An anesthetized dog was bled to death and a lobe of the liver removed, cut in slices, as much blood pressed out as possible, and a saline extract of it made, as above described. The main portion of the liver was washed through the portal vein with 0.9 per cent sodium chloride solution until the organ was just colorless. Another lobe was then removed and an extract of exactly the same concentration as the first one made of it. The remaining portion of liver was then perfused for a further period of fifteen minutes, being meanwhile massaged, and an extract prepared as above.

One cubic centimetre of the first extract when incubated for eight hours with 20 c.c. of 1 per cent glycogen solution caused 41.5 per cent of this to disappear. A similar preparation with the second extract gave 27.4 per cent glycogenolysis, and the third, 28.6 per cent. The first extract was strongest, because the liver from which it had been prepared still contained blood, but the second and third extracts were of equal glycogenolytic strength. The prolonged washing with saline had removed no more ferment from the viscus than the moderate washing, which, we believe, makes it highly improbable that retained lymph can be held accountable for the action.

It seems far more reasonable to assume that the ferment is contained inside the liver cells, that it is fixed somehow to the protoplasm just as erepsin has been shown by Vernon to be fixed "by some definite chemical bond" to the cells of the viscus.

This conclusion leads us to a consideration of the question of how the ferment comes to be present in the liver cells: has it wandered into them from the blood or has it been produced by the cells themselves?

<sup>52</sup> VERNON: *Intracellular enzymes*, London, John Murray, 1908, p. 3.



The undoubted assumption of great glycogenolytic activity by the liver, when certain portions of the nervous system are stimulated, *e. g.*, pi-*q*ûre, stimulation of the splanchnic nerves, etc., would tend to indicate that the ferment must be produced by the cells themselves, and, like other secretory mechanisms, that this mechanism is under nervous control. If such be not the case, then we must assume that the nervous influence is not over the secretory activities of the hepatic cells, but over the absorbability by these cells of the glycogenase in the blood and lymph. The vascular disturbance, which in all the above cases of stimulation of nerves, etc., undoubtedly occurs in the liver, must have, as a result, the bringing together of the blood ferment with the glycogen deposited in the hepatic cells. This, it will be remembered, was the view of Claude Bernard,<sup>53</sup> and from the results of the present research there is as much evidence in support of it as of the opposite hypothesis that the hepatic cells secrete glycogenase.

In support of it may also be brought forward the fact that an extract of perfectly blood-free muscle possesses a relatively feeble glycogenolytic power, although in the intact organism there is, unquestionably, a considerable glycogenolysis in the muscular tissues. The apparent want of parallelism between the amount of glycogen in the liver and the glycogenolytic strength of extracts of it is another fact which supports the view that it is the blood ferment and not a locally produced hepatic glycogenase which is responsible for the hydrolysis of glycogen under normal conditions.

The control which the nervous system exercises over the production of sugar by the liver may, as McGuigan and Brooks<sup>54</sup> have suggested, be on the stability of a glycogen-protoplasm (proteid) compound. So long as the glycogen is bound to proteid, it may be unacted on by the glycogenolytic ferment which the liver cell has appropriated from the blood; the nervous system may have an influence on this combination possibly by its leading to the secretion by the hepatic cell of some other enzyme which disrupts the compound, and therefore renders the glycogen open to attack by the diastase.

Bang,<sup>55</sup> etc., recognized the possibility that the diastatic power of the liver may be due to the blood and lymph diastases. They state, how-

<sup>53</sup> CLAUDE BERNARD: *Leçons sur le diabète*, Paris, Bullaire et Fils, 1877, p. 371.

<sup>54</sup> MCGUIGAN and BROOKS: *This journal*, 1907, xviii, p. 256.

<sup>55</sup> BANG, LJUNGAHL, and BOHM: *Loc. cit.*

ever, that there is besides this a specific liver enzyme, but *they furnish no definite evidence of this*, claiming that such will be apparent by an examination of the protocols throughout their paper. Since they merely washed the liver till it became pale and then used the mince of this in their incubation experiments, there may have been a considerable amount of lymph present, and it is difficult to see by an examination, in the manner that they suggest, on what grounds they so cursorily dismiss the question. The greatest glycogenolytic activity of their preparations was from rabbits that had been perfused before death through the jugular vein with sodium chloride solutions of various strengths, the greatest increase being found when extremely dilute (0.1 per cent) saline solutions were used. They ascribe the cause of this increase in glycogenolytic activity to an asphyxial action of the saline, and they find confirmation for this conclusion in the fact that deficiency of oxygen has a similar effect, acting, they believe, on the nerve centres. As already pointed out, the result of the flushing of the system with saline may, however, have another explanation, viz., that by such a process diastatic ferment is transferred from the locus of its production in the body (pancreas?) to the liver and retained by the liver cell.

#### CONCLUSIONS.

1. The glycogenolytic action of the blood-free liver does not develop its full strength during a few hours' incubation with glycogen solution, unless some means be taken to break up the liver cells and thus set free the endo-enzyme.

2. Thorough pounding of the liver in a mortar with quartz sand and water or isotonic saline, the expression of the tissue juices in the Buchner press or trituration of the liver with alcohol and subsequent drying of the alcohol precipitate at low pressure, yield preparations which exhibit practically an equal glycogenolytic power when allowed to act on a glycogen solution for two or four hours. Of very much feebler power in this regard are pieces of intact liver, or liver which has merely been passed through a mincing machine.

3. By comparing the glycogenolytic activity of Buchner extracts of certain blood-free organs and of blood serum, it has been found that by far the greatest amount of glycogenase is present in the pancreas. The serum and liver come next. The kidneys, the intestines, and the mus-

cles contain variable amounts of the endo-enzyme, but always less than the blood serum.

4. In sixteen experiments in which the glycogenolytic power of blood serum was compared with that of a volume of Buchner extract of blood-free liver, which was equivalent to considerably more than a corresponding volume of liver tissue, it was found that the serum was markedly stronger in thirteen cases, about the same in one, and that the liver was stronger than the serum in two cases. The relative feebleness of the liver extracts is not due to the presence of the acids which develop in these: 1. because neutralized liver extract shows the same inferiority in glycogenolytic action, and, 2. because it takes a higher degree of acidity than could be developed by the small amount of liver extract taken in these experiments to have any influence on the action of glycogenase.

5. The addition of small quantities of acid and alkali to blood serum and Buchner extract of liver have an influence on the glycogenolytic power of these which is exactly the same as that which they have on the action of other diastatic ferments.

6. A comparison was made of the amount of glycogenase in blood serum and in Buchner extracts of blood-free liver of the dog, pig, rabbit, and lamb. The largest amount was found in the preparations from the dog, the others decreasing in strength in the order in which the animals are named. The preparations from the lamb were very feeble indeed. In all cases the liver and serum ran more or less parallel with one another, although in the numerous experiments in the dog it was found that a strict parallelism between glycogenolytic strength of serum and liver extract does not exist. The one may vary independently of the other in this animal.

7. The nutritive condition of the dog was not found to have any influence on the glycogenolytic activities of the serum and liver extracts.

8. Blood serum from the pancreatico-duodenal vein does not contain more glycogenolytic enzyme than that from the carotid artery.

9. The plasma and serum of blood possess the same amount of glycogenolytic enzyme.

10. Prolonged perfusion (fifteen minutes) of the liver with isotonic saline solution does not cause any diminution in the glycogenolytic power of an extract of the organ. This is taken as evidence against the view that the glycogenolytic activity of blood-free liver is due to lymph.

# A STUDY OF THE CONCENTRATION OF ANTIBODIES IN THE BODY FLUIDS OF NORMAL AND IMMUNE ANIMALS.

BY J. R. GREER AND F. C. BECHT.

[From the Hull Physiological Laboratory, University of Chicago.]

THE presence of antibodies of various kinds in the serum has long been known, and the concentration in that fluid has been studied, but the concentration of these bodies in the various body fluids has not been so carefully investigated. Hughes and Carlson<sup>1</sup> made a study of the concentration of hemolysins in some of the body fluids. This study was undertaken with the object in view of determining more points of difference between lymph and serum, hoping in that way to get some light upon the problem of lymph formation, and possibly also upon the point of origin of these antibodies. The work thus far has been confined to a study of the concentration of hemolysins, hemagglutinins, agglutinins for the bacillus typhosus, the protein precipitins, and the opsonins — bacterial and erythrocytic — in the serum, cervical lymph, thoracic lymph, pericardial fluid, cerebrospinal fluid, and aqueous humor of normal and immunized animals. No work has as yet been done on the bacteriolysin. We have not enough data to warrant any general conclusions, so will content ourselves with presenting briefly the facts under the various conditions studied.

The plan of study adopted was to determine first the concentration of antibodies in the body fluids of normal animals — cats and dogs; then the concentration in animals actively immunized by suitable injections; and finally, to study the passage of these antibodies from the blood into the other body fluids of animals passively immunized by the withdrawal of large quantities of blood, and the injection of an equal amount of blood from an actively immunized animal.

The body fluids were secured under sterile conditions. The animal was anesthetized with ether and intubated. Then small sterile canulæ

<sup>1</sup> HUGHES and CARLSON: This journal, 1908, xxi, p. 236.

provided with sterile rubber tubing were inserted into the cervical lymphatics and into the thoracic duct, and the lymph was drawn from these by means of sterile Pasteur pipettes. Pericardial fluid, cerebrospinal fluid, and aqueous humor were drawn from their respective chambers by means of Pasteur pipettes.

Careful notes were made in regard to the condition of the fluids, and, in most cases, where there was any contamination of a fluid with blood, the fluid was discarded. A few such contaminated fluids were kept, and used, for the purpose of determining what effect a little blood might have.

### I. HEMOLYSINS AND HEMAGGLUTININS.

In all our experiments on these antibodies the body fluids of dogs only were used. In most cases the corpuscles hemolyzed were those of the rabbit, but in a few cases were from horse and rat. Whatever the corpuscles used, they were made up in 5 per cent suspension in 0.9 per cent NaCl solution. Our method was to make dilutions of the fluids to be tested varying between 1 in 6, and 1 in 6144, incubating for one hour in a shaker, which insured thorough mixture during the period of incubation, and then putting the tubes in the ice box for from twelve to twenty hours for sedimentation before the final reading. All the fluids from the same animal were run at the same time in order to secure absolutely similar conditions. The amount of hemolysis was determined by comparing each tube with a scale. This scale consisted of ten tubes containing 100 per cent, 90 per cent, etc., of hemaglobin from this particular sample of corpuscles. No attempt was made to estimate closer than 10 per cent. The agglutinins were read from the same tubes as the hemolysins. The method of determining whether or not agglutination had occurred was to inspect the rim of passively sedimented corpuscles. If the rim was ragged agglutination had occurred, but if perfectly smooth no agglutination had occurred. At first this method was carefully supplemented by the use of the microscope, but was found so accurate that in later experiments we depended entirely upon the observation of the rim of the sedimented corpuscles.

**Results.** (A) *Normal*<sup>2</sup> *Animals.*—The concentration of hemolysins and hemagglutinins vary in normal animals within rather nar-

<sup>2</sup> The term "normal" means animals not previously immunized by us. We had no way of knowing what their history had been previous to being brought to the laboratory.

row limits. The variation is great enough, however, to make necessary the comparison between the body fluids of the same animal. Thus the comparison of ascites or edema fluid of one patient with the blood of another or of a normal person is of absolutely no value in showing the conditions under which the fluid was formed within the patient studied.

We would cite Table I and Table II as typical of the results obtained in normal dogs:

TABLE I.

*Dog 1. — Normal Animal. Rabbit Corpuscles.<sup>1</sup>*

Dilution.	Serum.		N. lymph.		Th. lymph.		Pericard.		Cerebro. sp.		A. humor.	
	H	A	H	A	H	A	H	A	H	A	H	A
1-6	100	—	10	+	60	+	0	0	0	0	0	0
1-12	90	+	0	0	40	+	0	0	0	0	0	0
1-24	60	+	0	0	0	0	0	0	0	0	0	0
1-48	0	0	0	0	0	0	0	0	0	0	0	0

<sup>1</sup> Control = 0.

From Table I it is apparent that the concentration of hemolysins and hemagglutinins is greater in serum than in any of the other body fluids, thoracic lymph comes next, and neck lymph third. There are no lysins or agglutinins in the other body fluids in this experiment. There is, however, another type of result, as shown in Table II.

From Table II it is apparent that the concentration of agglutinins may be higher in the thoracic lymph than in the serum, and the agglutinins may be present in pericardial fluid.

Of our ten experiments on normal dogs in seven we found the concentration of agglutinins highest in the serum; in two it was highest in the thoracic lymph; and in one the concentration was the same in both. The fact that the concentration of the agglutinins may be greater in the thoracic lymph than in the serum renders it difficult to see how these antibodies can come from the blood into the lymph by pure filtration, for in that case we should expect the hemolysins to run a parallel

course — a thing which they do not do, as can be seen in Tables I and II, or else we must assume that the agglutinins pass through membranes more readily than the hemolysins. It would also be necessary on the basis of a filtration to assume sudden great changes in the concentration of the agglutinins in the blood, for on no other basis could we explain the fact that the concentration of agglutinins would be so much lower in the serum by the time the lymph reached the upper end of the thoracic duct than it was at the time the lymph was formed. Of

TABLE II.

*Dog 14.* — Normal. Rabbit Corpuscles.<sup>1</sup>

Dilution.	Serum.		N. lymph.		Th. lymph.		Pericard.		Cerebro. sp.		A. humor.	
	H	A	H	A	H	A	H	A	H	A	H	A
1-6	100	—	10	+	40	+	0	+	0	0	0	0
1-12	40	+	0	+	0	+	0	0	0	0	0	0
1-24	0	+	0	0	0	+	0	0	0	0	0	0
1-48	0	0	0	0	0	+	0	0	0	0	0	0
1-96	0	0	0	0	0	0	0	0	0	0	0	0

<sup>1</sup> Control = 0.

course other explanations are possible; there may be an active secretion of the agglutinins into the lymph from the blood, or the agglutinins after being formed in the area drained by the thoracic duct are thrown into the lymph, reaching the blood by that route. Much more investigation must be made before any conclusion can be reached on this point.

The pericardial fluid from normal dogs, when collected under the best of conditions, does not show hemolysis of rabbit corpuscles. In four of ten normal dogs hemolysis was noted. Two were in poor condition, and the pericardial cavity contained an excessive amount of fluid. In the two remaining cases in which hemolysis appeared there was contamination with blood. Agglutinins were found in the pericardial fluid in seven of the ten cases. From these experiments we conclude that in

normal animals in good condition no hemolysins are found in the pericardial fluid, agglutinins may or may not be present.

As will be seen from Tables I and II, the cerebro-spinal fluid and aqueous humor of normal dogs contained no hemolysins or hemagglutinins for rabbit corpuscles. In ten experiments on normal animals there were no traces of hemolysins or agglutination in the dilutions used.

(B) *Blood Immune Animals.*—Various methods of producing active immunity were employed with good success. Apparently the use of repeated, small intraperitoneal injection yielded the most uniform results. We usually employed the whole blood for immunization. We realize that this method is ideal for the production of anti-amboceptor and anti-complement, but Ehrlich<sup>3</sup> has shown that these anti-antibodies are not developed in dogs. Neither do our results show any such phenomena.

As has been noted before by numerous investigators, the increase in complement does not keep pace with the increase in amboceptors. The normal concentration of the lysin, or rather complement, and agglutinin in an immune animal, is shown very well in the experiment given in Table III. It gives the effect of the addition of normal guinea pig serum as complement in doses of itself non-hemolytic.

This experiment shows very clearly that in the immunized dog the serum, neck lymph, thoracic lymph, and pericardial fluid do not contain complement in sufficient quantities to activate all the amboceptors present in those fluids. The addition of complement in a non-hemolytic dose is able to cause hemolysis in the pericardial fluid. In eight of thirteen experiments we noted hemolysis in the lowest dilution in the pericardial fluid when no complement had been added. Apparently then in dogs immune to foreign blood amboceptor is always, and complement usually, present in the pericardial fluid. This agrees with the findings of Mioni.<sup>4</sup> No lysins were found in cerebrospinal fluid or aqueous humor.

The agglutinins, as may be seen from Table III, run practically parallel with those of the normal animal, except that the concentration is much higher. The concentration is highest in the serum, a little lower in the thoracic lymph, still lower in the neck lymph, and lowest

<sup>3</sup> EHRlich and MORGENROTH: *Berliner klinische Wochenschrift*, 1900, No. 31, p. 681.

<sup>4</sup> MIONI: *Comptes rendus de la Société de Biologie*, 1903, lv, p. 1592.



TABLE III.

*Dog 37.* — Large brindle and white bull dog, which was immunized to rabbit blood as follows: Dec. 1, 6 c.c.; Dec. 5, 7½ c.c.; Dec. 10, 10 c.c.; Dec. 15, 15 c.c.; Dec. 21, 16 c.c.; Jan. 5, 20 c.c.; Jan. 16, 20 c.c. Operated Feb. 8, and fluids kept in ice box over night. Incubated in shaker one hour at 37° C. Tests in ice box over night. 0.2 c.c. normal guinea pig serum for complement.<sup>1</sup>

Dilution.	Serum.		N. lymph.		Th. lymph.		Pericardial.		Cerebrospinal.		A. humor.						
	Uncomp.	Comp.	Uncomp.	Comp.	Uncomp.	Comp.	Uncomp.	Comp.	Uncomp.	Comp.	Uncomp.	Comp.					
													H	A	H	A	H
1-6	100	-	60	+	100	-	100	-	0	+	0	0	0	0	0	0	0
1-12	100	-	10	+	70	+	100	-	0	+	0	0	0	0	0	0	0
1-24	90	+	0	+	40	+	20	+	0	+	0	0	0	0	0	0	0
1-48	10	+	0	+	20	+	0	+	0	+	0	0	0	0	0	0	0
1-96	0	+	0	0	0	0	0	+	0	0	0	0	0	0	0	0	0
1-384	0	+	0	0	0	0	0	0	0	0	0	0	0	0	0	0	0
1-1536	0	0	0	0	0	0	0	0	0	0	0	0	0	0	0	0	0
1-6144	0	0	0	0	0	0	0	0	0	0	0	0	0	0	0	0	0

<sup>1</sup> Control = 0. Complement control = 0.

but always present in the pericardial fluid. Sometimes as in the normal animal the concentration of agglutinins in thoracic lymph is equal to, or greater than that of the serum. This was the case in five of sixteen experiments.

Agglutination was found in only two of fifteen experiments in which the cerebrospinal fluid of immune dogs was used. Agglutinins were found in five of sixteen experiments where aqueous humor was used. Thus, while agglutinins may be found in both cerebrospinal fluid or aqueous humor, their presence is the exception and not the rule.

## II. PROTEIN PRECIPITINS.

Since most investigators have agreed that the precipitin reaction is specific and delicate, we selected these antibodies for study in our problem. Many of the animals used were the same as those used in the study of hemolysins and agglutinins.

The method employed was the ordinary dilution method. Immune or normal serum varying in amount between 0.2 c.c. and 0.01 c.c. were placed in test tubes and made up to 2 c.c. with sterile 0.9 per cent NaCl. To this was then added 0.15 c.c. of the homologous serum. Suitable controls were made. The tubes were then incubated for two hours at 37° C., and then kept in the ice box twelve to twenty-four hours for sedimentation, before the final readings were taken.

Our results were as follows: in three normal dogs no precipitins for rabbit serum were found in dilutions varying between 1 in 10, and 1 in 200. In experiments performed with the fluids of seven dogs immune to rabbit blood three gave positive, and four gave negative results.

Dog No. 10 gave the typical results, so we will cite this experiment (see Table IV). From this experiment it is evident that the concentration of the precipitins in the body fluids of animals runs almost perfectly parallel with the concentration of the antibodies, already described. Namely, they are as concentrated or almost as concentrated in the thoracic lymph as in the serum, less concentrated in the neck lymph, and wanting in the pericardial fluid, cerebrospinal fluid, and aqueous humor.

In five attempts to produce precipitins in dogs by immunizing with horse serum we were successful only once.

Our data are not uniform enough nor extensive enough to warrant

conclusions. It is evident, however, that dogs develop precipitins with extreme difficulty. Apparently they will resemble the hemagglutinins in their distribution in the body fluids of immune animals, although as yet we have not been able to find precipitins in the pericardial fluid. Much more work is necessary on these antibodies.

TABLE IV.

*Dog 10.* — Immunized by the intraperitoneal injection of 80 c.c. of rabbit blood, ten days before operation for fluids. Incubated two hours at 37° C. In ice box over night.<sup>1</sup>

Body fluid.	NaCl.	Rabbit serum.	Dilut.	Serum.	N. lymph.	Th. lymph.	Peric.	Cereb.	A. humor.
c.c. 0.20	c.c. 1.80	c.c. 0.15	1-10	++	+	++	0	0	0
0.15	1.85	0.15	1-15	++	+	++	0	0	0
0.10	1.90	0.15	1-20	++	+	++	0	0	0
0.05	1.95	0.15	1-40	+	0	+	0	0	0
0.01	1.99	0.15	1-200	0	0	0	..	..	..
0.20	1.80	0.00	....	0	0	0	0	0	0

<sup>1</sup> Rabbit serum control = 0.

### III. BACTERIAL AGGLUTININS.

We also made a study of the concentration of the agglutinins for *B. typhosus* in the body fluids of normal and immunized cats and dogs, and later will extend the work to cover the bacteriolysins. A great deal of scattered work has been done on various body fluids in this connection, but in very few cases has the comparison between body fluids and serum from the same animal been made. Brande and Carlson<sup>5</sup> made a study of the agglutinins for *B. typhosus* in normal and immunized animals, and inasmuch as the fluids were all collected from the same animal and used upon the same bacterial suspension, their results show more nearly the true condition in the animal, and avoid the error of attempting to compare body fluids drawn from different animals.

The hanging drop method they employed is hardly so accurate as

<sup>5</sup> BRANDE and CARLSON: This journal, 1908, xxi, p. 221.

the macroscopic test which we used. They found bacterial agglutinins in the cerebrospinal fluid of immunized cats and dogs.

The fluids were collected for these experiments in exactly the same way as for the other antibodies. We used the Gruber-Widal technique for the tests. The bacteria were secured from twenty-four-hour slant agar cultures, suspended in 0.9 per cent NaCl solution. The suspension was filtered to remove clumps. The dilutions used were 1-10, 1-50, 1-100, 1-500, 1-2000, 1-6000. The tubes were all incubated for two hours at 37° C., and kept in the ice box for twelve to twenty-four hours before the final reading.

Our observations were confined to the fluids of cats and dogs, and covered the following conditions: (1) Normal animals. (2) Animals actively immunized by subcutaneous injections. (3) Animals passively immunized by the removal of a large amount of normal blood and the subsequent injection of an equal amount of defibrinated immune blood from an animal of the same species.

(A) *Normal animals. Cats.*—We studied the concentration of agglutinins in the body fluids of normal cats. The following table shows the result:

TABLE V.

Animals apparently perfectly healthy, and well fed. Tubes incubated two hours. In ice box over night.<sup>1</sup>

Dilu- tion.	Serum.			N. lymph.			Th. lymph.			Peric. fl.			Cereb. fl.			A. humor.		
	Cat 1	Cat 3	Cat 8	Cat 1	Cat 3	Cat 8	Cat 1	Cat 3	Cat 8	Cat 1	Cat 3	Cat 8	Cat 1	Cat 3	Cat 8	Cat 1	Cat 3	Cat 8
1-10	+	+	+	0	+	+	+	+	+	0	+	+	0	0	0	0	0	0
1-50	0	0	0	0	0	0	0	0	0	0	0	0	0	0	0	0	0	0
1-100	0	0	0	0	0	0	0	0	0	0	0	0	0	0	0	0	0	0
1-500	0	0	0	0	0	0	0	0	0	0	0	0	0	0	0	0	0	0

<sup>1</sup> Control = 0.

From this experiment it appears that agglutinins active in a dilution of 1-10 are found in the thoracic lymph and serum of normal cats.

Neck lymph and pericardial fluid usually contain them, but cerebrospinal fluid and aqueous humor do not.

*Dogs.* — The following table shows the concentration of agglutinins in normal dogs:

TABLE VI.

*Dog No. 4.* — Normal animal. Tubes in incubator two hours at 37° C. In ice box over night.<sup>1</sup>

Dilution.	Serum.	N. lymph.	Th. lymph.	Peric.	Cerebro.	A. hum.
1-10	++	++	++	0	0	0
1-50	++	0	0	0	0	0
1-100	+	0	0	0	0	0
1-500	0	0	0	0	0	0

<sup>1</sup> Control = 0.

This shows a typical experiment, although there are slight variations between animals of the same species; in all the concentration of agglutinins was highest in the serum, lower in the lymphs. Agglutinins were found only once in the pericardial fluid and not at all in the cerebrospinal fluid and aqueous humor.

(B) *Actively Immunized Animals.* *Cats.* — These animals were immunized in the usual way by repeated subcutaneous injections in most cases, but in some by a single large dose. We would cite Table VII as a perfectly typical experiment.

This experiment shows what we believe to be the true state of affairs as regards the agglutinins in the immunized cat. It will be seen that serum agglutinates at a dilution of 1-6000, thoracic lymph at 1-500, and neck lymph at 1-100. Pericardial fluid agglutinates in a dilution of 1-10, cerebrospinal fluid and aqueous humor show only traces in 1-10. Our other experiments confirm the results secured in this one, although there are, as might be expected, some variations. In some cases the thoracic lymph agglutinated bacteria in as high a dilution as the serum, in one case the neck lymph agglutinated in as many dilutions as the thoracic lymph. In no case was there clearly an agglutination in the cerebrospinal fluid or aqueous humor.

TABLE VII.

A fine cat in good condition. Weight 4+K. Immunized by repeated subcutaneous injections. Operated five days after last injection. All fluids in perfect condition. Tubes incubated two hours at 37° C. In ice box over night.<sup>1</sup>

Dilution.	Serum.	N. lymph.	Th. lymph.	Peric.	Cerebro.	A. hum.
1-10	++	++	++	+	?	?
1-50	++	++	++	0	0	0
1-100	++	++	++	0	0	0
1-500	++	0	+	0	0	0
1-2000	+	0	0	0	0	0
1-6000	+	0	0	0	0	0

<sup>1</sup> Control = 0.

*Dogs.* — We would cite Table VIII as typical of the result secured from immunized dogs.

TABLE VIII.

*Dog 25.* — Immunized by repeated subcutaneous injections of *B. typhosus*. Incubated two hours at 37° C. In ice box over night.<sup>1</sup>

Dilution.	Serum.	N. lymph.	Th. lymph.	Peric.	Cerebro.	A. hum.
1-10	++	++	++	++	0	0
1-50	++	++	++	++	0	0
1-100	++	++	++	+	0	0
1-500	++	+	++	0	0	0
1-2000	+	0	+	0	--	--
1-6000	0	0	0	0	--	--

<sup>1</sup> Control = 0.

As may be seen in this table, the agglutinins in immune dogs run a course parallel with those in the cat, except that they are more markedly

developed in the pericardial fluid. In the majority of cases (4 of 7 the concentration of agglutinins was the same in serum and thoracic lymph. In no case was there agglutination in the cerebrospinal fluid, but in three of six cases there were traces in the aqueous humor.

(C) *Passively immunized animals.* — There is abundant evidence in the literature that antibodies can pass through membranes, so we hoped that a study of the appearance of these antibodies in the various body-fluids in passively immunized animals might throw some light on the problem of lymph formation. Thus far we have been disappointed, for our results have been hardly decisive enough to warrant many conclusions.

To show the concentration of antibodies in passively immunized cats we will present the following experiment :

TABLE IX.

*Cat 11.* — Immunized by the subcutaneous injection of six live twenty-four-hour slant agar cultures of *B. typhosus*, June 29, 1909. Operated July 9.

*Cat 12.* — Passively immunized by the withdrawal on July 9 of 100 c.c. of blood and the injection of 100 c.c. of blood from Cat 11. Operated July 10. Tubes incubated two hours at 37° C. In ice box over night.<sup>1</sup>

Dilution.	Serum.			N. lymph.		Th. lymph.		Peric.		Cerebro.		A. hum.	
	Cat 11.	Nor. Cat 12.	Pas. Im. Cat 12.	Cat 11.	Cat 12.	Cat 11.	Cat 12.	Cat 11.	Cat 12.	Cat 11.	Cat 12.	Cat 11.	Cat 12.
1-10	++	+	++	++	++	++	++	+	0	0	0	0	0
1-50	++	+	+	++	+	++	+	+	0	0	0	0	0
1-100	++	0	+	+	0	+	+	0	0	0	0	0	0
1-500	+	0	+	+	0	+	0	0	0	0	0	0	0
1-2000	+	0	0	+	0	+	0	0	0	..	..	..	..
1-6000	0	0	0	0	0	0	0	0	0	..	..	..	..

<sup>1</sup> Control = 0.

From this experiment it is evidently possible to increase the concentration of agglutinins in the lymph of a normal animal as well as in

the blood serum by the injection of blood from an immune animal. The comparative concentration of agglutinins remains the same in the various body fluids as in the actively immunized animal of the same degree of immunity. In no case was the concentration of agglutinin in the pericardial fluid increased over the normal. Cerebrospinal fluid and aqueous humor show no increase over the normal, nor would it be expected, since in the actively immunized animal these fluids show these antibodies in traces only, if at all. Passive immunity produced in dogs in the same way yielded exactly similar results: the concentration of agglutinins in the serum, neck lymph, and thoracic lymph is increased; the concentration of agglutinins in the pericardial fluid, cerebrospinal fluid, and aqueous humor remains the same as in the normal animal.

In an experiment conducted with the object of finding the time required for the passage of the antibodies, it was found that the concentration of agglutinins in the lymph was the same at the end of four and one half hours as at the end of twenty-four hours. Thus the passage of the antibodies from serum to lymph is a relatively rapid process.

#### IV. OPSONINS.

We also made a study of the opsonins in the body fluids. While much work has been done with the serum, but little work has been reported in which a careful comparative study of the concentration of that antibody in the body fluids of animals was made.

The body fluids were secured as described above. The bacterium used was the *Staphylococcus aureus* in fairly rich suspension in 0.9 per cent NaCl from a twenty-four-hour slant agar culture. The leucocytes were from the exudate into the pleural cavity of a young dog, following an aleuronat injection. They were drawn into warm 1 per cent citrate and then carefully washed in warm 0.9 NaCl. The technic used was essentially that of Walker. The pipettes were incubated twenty minutes at 37°, smears were made, fixed with absolute alcohol, and stained with Giemsa stain or with carbol-thionin. From 60 to 100 leucocytes were counted, but the number was constant in each experiment. The slides were so labelled that the person counting had no way of knowing what the slide contained, thus eliminating the personal equation.



**Results.** *Normal animals.*— We would cite the following experiment as typical of our results on normal dogs:

TABLE X.

*Normal Dog.*— Fluids all in good shape. Twenty-four hours on ice. Leucocytes from a plural exudate. Pipettes incubated twenty minutes. Smears stained with Giemsa. Opsonic index for *Staphylococcus aureus*.<sup>1</sup>

Dilution.	Serum.	N. lymph.	Th. lymph.	Peric.	Cerebro.	A. hum.
Whole	3.40	3.50	4.17	0.81	1.01	1.08
1-10	0.30	0.16	0.58	0.32	.....	.....

<sup>1</sup> Control = 0.36.

In this experiment it appears that the phagocytosis is much higher in the serum, neck lymph, and thoracic lymph than in the three remaining body fluids. This is true in all of nine experiments on normal animals, and in most cases the phagocytosis is highest in the serum. Opsonins were found in the cerebrospinal fluid in four of seven cases of normal dogs, they were found in the aqueous humor in five of eight cases, and in the pericardial fluid in three of seven cases.

*Immune animals.*— We found it difficult to increase to any marked degree the opsonin for *Staphylococcus*, probably because of the fact that the animals are being constantly infected mildly, and thus immunized. We would cite Table XI as typical.

It is to be noted that the results obtained in these experiments are exactly comparable to those obtained in all the other antibodies studied. The concentration of opsonin is higher in the serum than in any of the other body fluids. The lymphs are nearly equal with a slight balance in favor of the thoracic. The other body fluids contain the opsonin, but in a much lower concentration. This experiment is confirmed by numerous others.

*Hemopsonins.*— So far as is known to the authors no work has been published upon the hemopsonins in the various body fluids. The method employed is that recommended to us by Professor Hektoen. The fluids were inactivated by heating to 55° C. for thirty minutes. Washed rat corpuscles were used. The method employed was to measure varying amounts of the fluids to be tested into small test tubes, and

make up to a constant quantity with 0.9 per cent NaCl, and then add a mixture of erythrocytes and leucocytes. The tubes were incubated for sixty minutes at 37° C. Smears were made, fixed in absolute alcohol, and stained with Giemsa stain. Percentages were calculated from

TABLE XI.

Animal injected subcutaneously with six slant agar cultures suspended in sterile 0.9 per cent NaCl. Operated on tenth day. Leucocytes from a twenty-four-hour pleural exudate produced in a young dog by aleuronat. Bacteria from a twenty-four-hour slant agar culture. Pipettes incubated twenty minutes. Smears made and stained with carbol thionin.<sup>1</sup>

Dilution.	Serum.	N. lymph.	Th. lymph.	Peric.	Cerebro.	A. hum.
Whole	10.07	5.51	5.95	3.30	1.85	0.78
1-10	4.51	1.75	3.51	1.33	0.88	0.50
1-50	1.75	0.86	1.01	0.22	0.28	0.28

<sup>1</sup> Control = 0.22.

the number of leucocytes actively phagocytic. Five hundred leucocytes were counted in every case. Our figures thus show the percentage of leucocytes phagocytic, and show only the activity of the thermostable opsonin.

*Normal dogs.* — We would cite the following experiment as typical of the results in normal dogs:

TABLE XII.

*Normal Dog.* — Weight 14 K. Incubated one hour in shaker at 37° C. Dog leucocytes. Five per cent suspension washed rat corpuscles. Giemsa stain. Average from 500 leucocytes.<sup>1</sup>

Contents of tubes.				Results.					
Fluid.	NaCl.	Leuc.	Eryth.	Serum.	N. lymph.	Th. lymph.	Peric.	Cereb.	A. hum.
cc.	cc.	cc.	c.c.						
0.2	....	0.2	0.2	3.2	1.2	0.6	0.0	0.4	0.2
0.1	0.10	0.2	0.2	0.2	0.0	0.2	0.0	0.0	0.0
0.05	0.15	0.2	0.2	0.2	0.0	0.0	0.0	0.0	0.0

<sup>1</sup> Control = 0.

The concentration of the hemopsonin thus is seen to run a course parallel with that of the other antibodies.

*Immune animals.* — In establishing immunity in the case of the hemopsonins we always injected intravenously 0.5 c.c. of a 5 per cent suspension of washed corpuscles per kilo of body weight. The animal was then operated on the tenth day and the fluids studied.

TABLE XIII.

*Dog 13.* — Young immune dog in good condition. Dog leucocytes. Five per cent suspension washed rat corpuscles. Tubes incubated one hour at 37° C. Giemsa stain.<sup>1</sup>

Contents of tubes.				Results.						
Fluid.	NaCl.	Leuc.	Eryth.	N. serum.	Im. serum.	N. lymph.	Th. lymph.	Peric.	Cerebro.	A. hum.
c. c.	c. c.	c. c.	c. c.							
0.2	....	0.2	0.2	24.4	45.0	43.4	39.4	25.8	10.8	4.8
0.1	0.1	0.2	0.2	4.2	38.4	28.0	28.2	15.0	2.6	1.0
0.05	0.15	0.2	0.2	1.8	24.6	5.0	14.6	7.0	1.2	0.0
0.025	0.17	0.2	0.2	0.4	5.8	3.0	2.2	2.0	0.2	0.0
0.010	0.19	0.2	0.2	0.0	2.6	2.0	0.0	0.0	0.0	0.0
0.005	0.19	0.2	0.2	....	1.0	0.8	0.0	....	....	....
0.002	0.19	0.2	0.2	....	0.2	....	....	....	....	....

<sup>1</sup> Control = 0.

From Table XIII it can be seen that the degree of immunity established was considerable, the use of the immune serum producing a much higher percentage of phagocytosis than the normal. The concentration was highest in the serum, practically equal in the lymphs with a slight balance in favor of the neck lymph. Pericardial fluid is much lower, and cerebrospinal fluid and aqueous humor lower than the pericardial fluid. These results are confirmed by other experiments.

From the work cited above the following conclusions seem warranted:

(1) In the normal dog hemolysins for rabbit corpuscles are found in the serum, neck lymph, and thoracic lymph; but are absent from the pericardial fluid, cerebrospinal fluid, and aqueous humor. They are

most concentrated in the serum, less concentrated in thoracic lymph, and are found only in traces in the neck lymph.

(2) Agglutinins for rabbit corpuscles are found in the serum, neck lymph, and thoracic lymph of normal dogs. They may or may not be present in the pericardial fluid, and are not found in the cerebrospinal fluid, or aqueous humor. In most cases the concentration diminishes in the following order: serum, thoracic lymph, neck lymph, pericardial fluid, but in some cases the order is thoracic lymph, serum, neck lymph, pericardial fluid.

(3) In dogs immune to a heterologous blood hemolysins are found in the serum, neck lymph, thoracic lymph, and usually in the pericardial fluid. They are not found in the cerebrospinal fluid nor in the aqueous humor. The concentrations vary in the various fluids as in the normal animal.

(4) The addition of guinea pig serum as complement in non-hemolytic doses increases greatly the hemolytic power of the serum, neck lymph, thoracic lymph, and pericardial fluid; therefore in the course of immunization the amboceptors are developed in all the body fluids in which they are normally found more rapidly than is the complement. Cerebrospinal fluid and aqueous humor do not become hemolytic even on the addition of complement, therefore they do not contain amboceptors.

(5) In an immunized dog the agglutinins are much more concentrated than in the same body fluids of the normal animal. The usual order of descending concentration is serum, thoracic lymph, neck lymph, pericardial fluid; but the order may be thoracic lymph, serum, neck lymph, pericardial fluid. Cerebrospinal fluid and aqueous humor may or may not have agglutinins present. If agglutinins are present, the concentration in the two fluids is equal and less than in the pericardial fluid.

(6) Precipitins for rabbit serum are not present in the body fluids of normal dogs active in a dilution of 1 in 10. Dogs do not develop precipitins for rabbit serum readily. If precipitins are developed, their distribution is the same in the body fluids as the hemagglutinins.

(7) Agglutinins for the *B. typhosus* active in a dilution of 1 in 10 are found in the serum, neck lymph, thoracic lymph, and usually in the pericardial fluid of normal cats. Cerebrospinal fluid and aqueous humor do not contain them. In general, the same is true for normal dogs, but in the case of the latter the pericardial fluid was less likely to contain agglutinins.

(8) Agglutinins for *B. typhosus* are found in actively immunized cats in the serum, thoracic lymph, neck lymph, and pericardial fluid in decreasing concentration in the order mentioned. If found in the cerebrospinal fluid or aqueous humor, there are only traces.

(9) Agglutinins for *B. typhosus* are found in actively immunized dogs in the serum, thoracic lymph, neck lymph, and pericardial fluid, usually in decreasing concentration in the order named. Serum and thoracic lymph may show an equal concentration. Cerebrospinal fluid shows no agglutinins in a dilution of 1 in 10. Aqueous humor may or may not show traces of agglutination in a dilution of 1 in 10.

(10) In the passively immunized animal the agglutinins pass readily from the blood stream into the lymphs. They do not pass into the pericardial fluid, cerebrospinal fluid, or aqueous humor. The time required for this passage is relatively short, being as complete in four and one half hours as in twenty-four hours.

(11) Bacterial opsonins are found in the body fluids of normal dogs in considerable quantities. The serum usually contains the most; the two lymphs — thoracic and neck — are about equal, with a slight balance in favor of the former. Pericardial fluid, cerebrospinal fluid, and aqueous humor may contain opsonins for *Staphylococcus pyogenes aureus*, but rarely in amounts comparable to the fluids mentioned above. Immunization by repeated subcutaneous injections does not increase the opsonins to any very marked extent.

(12) Hemopsonins are found in the body fluids of normal animals. They are most concentrated in the serum lower in the neck and thoracic lymphs, which run almost parallel, and are found only in traces in the pericardial fluid, cerebrospinal fluid, and aqueous humor.

(13) The concentration of hemopsonins in the body fluids can be increased by immunization. The order of descending concentration is serum, neck and thoracic lymph, pericardial fluid, cerebrospinal fluid, aqueous humor. Sometimes the arrangement in the scale is reversed as regards the last two.

We wish to thank Dr. Carlson of this laboratory for his help and encouragement, and also Dr. Hektoen of Rush Medical College for his helpful suggestions.

# ACAPNIA AND SHOCK.<sup>1</sup>—IV. FATAL APNŒA AFTER EXCESSIVE RESPIRATION.

By YANDELL HENDERSON.

(WITH THE COLLABORATION OF JAMES RYLE COFFEY AND CHARLES GARDINER BARNUM.)

[From the Physiological Laboratory of the Yale Medical School.]

## CONTENTS.

	PAGE
I. The relations of pain, hyperpnœa, and shock . . . . .	310
II. Failure of respiration after forced breathing . . . . .	315
III. Fatal apnœa after artificial respiration . . . . .	321
Conclusions . . . . .	332

## I. THE RELATIONS OF PAIN, HYPERPNŒA, AND SHOCK.

**P**AIN is one of the natural stimuli evoking hyperpnœa. The crying of a child, the rapid sequence of deep inspirations and forcible expirations in an adult under physical suffering or mental anguish are familiar phenomena. Because of this familiarity they have been little studied. The object of this series of papers is to demonstrate that the functional disturbances and diminished vitality consequent upon pain are mainly due to excessive pulmonary ventilation.

The ill effects of suffering are generally supposed to be the expression of fatigue of the nerve centres and of the heart by the overpowering strength of the inflowing sensory irritations. Upon this topic there is available a considerable mass of experimental data. Porter has shown that it does not support the current conception of the etiology of shock. From the work of this investigator and his collaborators<sup>2</sup> and from our own experiments it appears highly probable that the symptom-complexes spoken of as "fatigue of the respiratory centre," "fatigue of the vaso-motor centre," and "fatigue of the heart,"<sup>3</sup> are really states quite

<sup>1</sup> For the earlier papers of this series see This journal, 1908, xxi, p. 126; 1909, xxiii, p. 345 and p. xxx; and 1909, xxiv, p. 66.

<sup>2</sup> PORTER and QUINBY: This journal, 1908, xx, p. 505.

<sup>3</sup> HENDERSON, Y.: This journal, 1908, xxi, p. 144, and 1909, xxiii, p. 362.

distinct from fatigue properly so called. These terms ought to be understood merely as confessions of our ignorance.

Every one instinctively recognizes that pain-hyperpnœa and anger-hyperpnœa are in themselves harmful. For a hurt child we try not only to remove the irritant, but even more to cut short the crying. One of the earliest and most important of the abilities which every child must develop, if it is to withstand the pains and anxieties of life, is to exert a voluntary inhibition upon hysterical respiration. A man striving against suffering directs his efforts mainly to control his breathing. If he fails, or, in other words, if the intensity of the afferent impulses from the locus of irritation to the respiratory centre exceeds the power of the inhibitory influence of the cerebrum, shock develops, and death may occur. To a man in great agony we administer morphin, — a drug whose most pronounced effect is to quiet the respiration. All the pain-relieving procedures of surgery accomplish the end of preventing hyperpnœa.

The chain of causes by which hyperpnœa induces shock might be nervous, mechanical, or chemical. We have found that shock follows excessive pulmonary ventilation in dogs with the vagi cut as readily as in animals with these nerves intact. Thus the first possibility is excluded. The second also is untenable. The movements of the thorax and their mechanical effects upon the circulation are not essentially different in pain-hyperpnœa from the movements and effects induced by breathing vitiated air, or from those incident to muscular exercise, — if not too vigorous and prolonged. Yet neither of these last two forms of hyperpnœa is followed by shock. There are minor differences in these forms of breathing. Sensations, emotions, and other nervous influences appear to affect the respiratory centre more in the rate of its efferent discharges than in respect to their strength. The activity of the costal muscles is altered by nervous influences more than is that of the diaphragm. In these points the hyperpnœa of muscular work and of vitiated air differs from that of pain. But in their bearing upon the etiology of shock these differences are insignificant.

From the chemical stand-point there is a profound difference between pain-hyperpnœa and the normal forms of augmented respiration. In breathing vitiated air the augmentation counterbalances, at least in great part, the quantity of  $\text{CO}_2$  inhaled. In muscular work the augmentation compensates the increased gaseous exchange of the tissues.

Under both of these conditions respiration strives to maintain the gases in the blood, nerve centres, and tissues at their normal amounts. *Intense irritation of afferent nerves, on the contrary, perverts respiration from its normal chemical adjustments.* The pulmonary ventilation is in excess of the needs of the body. The  $\text{CO}_2$  content of the arterial blood is reduced below the normal amount. The condition of acapnia (so named by Mosso<sup>4</sup>) which thus develops is identical with that produced in animals by vigorous artificial respiration, and with that induced in man by voluntary forced breathing. Both of these procedures are followed, as is well known, by more or less prolonged failure of respiration.

This apnœa is due, as has been demonstrated especially by Haldane and Priestley,<sup>5</sup> to the lowering of the pressure of  $\text{CO}_2$  in the arterial blood below the threshold stimulating value for the respiratory centre. Many years ago Miescher<sup>6</sup> with keen intuition expressed the truth regarding the normal regulation of respiration, — “Carbon-dioxid spreads its protecting wings over the oxygen supply of the body.” Evidently this protection is withdrawn when the excessive pulmonary ventilation induced by pain has greatly diminished the  $\text{CO}_2$  content of the blood. Thereafter the maintenance of respiration depends upon the continuance of the inflow of intense sensory irritations. Whenever these cease, breathing stops. If the apnœa is sufficiently prolonged death must result from failure of the oxygen supply to the tissues. It is thus, as we believe, that shock terminates in the majority of all fatal cases, — certainly in the greater number of all the experiments upon this topic in the literature. Miescher called the cessation of respiration which results from deficiency of  $\text{CO}_2$  by the name apnœa vera. From the Miescher-Haldane theory it is to be expected that a man who has suffered intense and prolonged pain with the concomitant excessive breathing will become apnœic when anæsthetized. It would be easy to show that clinical experience verifies this theoretical expectation. Strikingly in accord with the acapnia hypothesis is the fact that prolonged ether-excitement, *i. e.*, the hyperpnœa of the second stage of anæsthesia, is a potent element in producing shock. Recognition of this relation is shown by implication in the modern use of nitrous oxide at the beginning of anæsthesia.

<sup>4</sup> For abstracts of Mosso's numerous investigations upon acapnia see Zentralblatt für Physiologie, 1904-1905, xvii and xviii.

<sup>5</sup> HALDANE and PRIESTLEY: Journal of physiology, 1905, xxxii, p. 252.

<sup>6</sup> MIESCHER-RUSCH: Archiv für Physiologie, 1885, p. 355.



Similarly in respect to shock from sorrow or fear<sup>7</sup> it is noteworthy that intense and uncontrolled emotion is expressed by hysterical breathing, and is followed by apnoea broken at intervals by gasps or sobs. Whether or not respiratory standstill in any given case will be prolonged, until death occurs from lack of oxygen, depends upon several factors, chief among which are the duration and intensity of the preceding hyperpnoea.

Fatal apnoea is possible because of the fact that the body normally contains an enormously greater quantity of CO<sub>2</sub> than of oxygen. In the blood there are 40 to 45 volumes per cent of dissociable CO<sub>2</sub>. Stintzing obtained 80 to 180 volumes per cent from muscle.<sup>8</sup> It is probable that the healthy human body contains at least half its own volume of CO<sub>2</sub> (25 or 30 litres at 0° and 760 mm. of Hg) dissolved in the humors and combined with the alkalies of the tissues in readily dissociable forms. The normal rate of production and elimination is about 0.3 litre per minute. On the supposition that during pain-hyperpnoea the elimination rises to 0.5 litre per minute, the deficit after thirty minutes of suffering would be 6.0 litres, or 20 per cent of the body's normal store. To replace this loss would require twenty minutes of complete apnoea.

The oxygen contained in the blood and in the pulmonary air of a man is less than 0.6 litre, or two minutes' supply.<sup>9</sup> From our experiments it is probable that the reserve stored in the muscle cells of the heart is sufficient for only four or five minutes of complete anoxaemia. Stewart<sup>10</sup> and his co-workers have found that an anaemia of ten to fifteen minutes irremediably ruins the cerebral centres, and that a period of three to five minutes usually renders the respiratory centre incapable of unassisted recovery. During anoxaemia the products of incomplete tissue combustion appear in the blood. Except for the inspirations which these substances excite, death from asphyxia, after six to eight minutes of apnoea vera, might be induced by only ten minutes of vigorous hyperpnoea.

Haldane and Poulton<sup>11</sup> have shown that lack of oxygen itself exerts

<sup>7</sup> CRILE says: "It would be indeed difficult to differentiate between prostration by fear and prostration by injury," in *Keen's Surgery*, 1906, i, p. 925.

<sup>8</sup> STINTZING, R.: *Archiv für die gesammte Physiologie*, 1878, xviii, p. 388; 1879, xx, p. 189; and 1880, xxiii, p. 151.

<sup>9</sup> Compare the experiment of Poulton quoted on p. 321 of this paper.

<sup>10</sup> STEWART, GUTHRIE, BURNS, and PIKE: *Journal of experimental medicine*, 1906, viii, pp. 300 and 317, refs. to literature.

<sup>11</sup> HALDANE and POULTON: *Journal of physiology*, 1908, xxxvii, p. 390.

no direct stimulating influence upon the respiratory centre. Furthermore the acidosis substances appearing in the blood during asphyxia are not independent stimulants, but exert their influence indirectly, — either by the addition of their acidity to that of the carbonic acid in the blood, or by the liberation of  $\text{CO}_2$  from the carbonates of the plasma, or by some other mode of summation of influences.<sup>12</sup> Thus it is to be expected that during apnœa, after hyperpnœa of less than twenty minutes, the addition of lactic and oxy-butyric acids and other asphyxial products to the carbonic acid remaining in the blood will usually suffice to prevent death. But after more prolonged hyperpnœa the diminution in the body's store of  $\text{CO}_2$  is so great that the sum of its influence and that of acidosis may not reach a total sufficient to excite the respiratory centre within the crucial period of eight minutes of apnœa.

In order to prove that failure of respiration and the other phenomena of shock after trauma are caused by acapnia, it is essential to demonstrate that —

(1) Voluntarily forced breathing induces in a normal man, so far as the experiment can be safely carried, the symptoms of shock.

(2) All the disturbances of function characteristic of surgical shock in the human subject occur in animals which have been subjected to excessive artificial respiration.

(3) Animals which have been brought into a condition of shock by trauma and by irritation of afferent nerves usually die in a manner concordant with the principles above quoted as governing respiration.

(4) Procedures which prevent excessive pulmonary ventilation likewise prevent shock and *vice versa*.

The data to be presented in this paper and the two following will be limited mainly to the field of respiration with only incidental references to other functions concerned in surgical shock. In later papers the disturbances of the circulation induced by acapnia will be dealt with. They will be shown to depend, not upon failure of the vaso-motor nervous system, but upon a diminution in the volume of the blood by processes similar to œdema, as held by Malcolm.

The partial pressure of  $\text{CO}_2$  in the tissues during rest is probably as high as the pressure of oxygen, — both are between 7 and 9 per cent of an atmosphere.

<sup>12</sup> The last-mentioned possibility appears to us more probable than either of the others.

A. B. Macallum<sup>13</sup> has offered a suggestive speculation regarding the concentration of the various salts in the blood and lymph. He holds that they are nearly the same as the quantities which were in solution in the sea water of the remote past when the ancestors of the modern higher animals were minute and simple pelagic creatures whose tissues were freely exposed to the medium in which they lived. It is interesting to notice that the cells composing the bodies of the mammals of to-day are incapable of living in modern air, but require an atmosphere similar to that of a pre-carboniferous age. The entire mechanism of respiration — pulmonary, circulatory, and nervous — in man and the higher animals is adjusted to maintain these palæochemical interior conditions. The necessity of CO<sub>2</sub> in the tissue atmosphere has been proved by L. J. Henderson.<sup>14</sup>

## II. FAILURE OF RESPIRATION AFTER FORCED BREATHING.

It has long been known that a voluntary increase of one's own respiration can with difficulty be maintained for more than a brief period. If it is continued vigorously for a couple of minutes, there result dizziness and throbbing in the head, and numbness or tingling in the hands and feet. The heart rate is greatly accelerated. When the effort is discontinued, a period of complete cessation of breathing follows automatically. During this pause a marked fall of arterial pressure was observed by Mosso.<sup>15</sup> Frequently there is also a feeling of faintness.

In order to observe the relations of these functional disturbances to each other and to acapnia, we have performed upon sixty young men the following pair of experiments. The plan of the investigation involved the comparison of the functional conditions after two periods of voluntary hyperpnœa, — one with, the second without, acapnia. The results throughout the series were so concordant that a single description will serve for all.

The subject lay down until the heart rate and breathing became uniform. Then with his mouth open he inhaled and expired as deeply and as rapidly as possible, until he felt considerable difficulty in continuing. Usually the effort was terminated after forty-five to ninety seconds, and apnœa immediately and spontaneously occurred. The

<sup>13</sup> MACALLUM, A. B.: Transactions of the Canadian Institute, 1903-1904, pp. 1-36.

<sup>14</sup> HENDERSON, L. J.: Ergebnisse der Physiologie, 1909, viii, p. 254.

<sup>15</sup> Mosso, A.: Archives italiennes de biologie, 1903, xl, p. 1.

subsequent return of natural breathing was entirely automatic and involuntary. After three minutes more the first experiment was ended. A rest of fifteen minutes was allowed, and the second experiment was then performed. A paper bag, or a rubber mask connected with a wide and long tube, was placed over the subject's nose and mouth. Five minutes later, when the respiration under these conditions had become uniform, hyperpnœa of the same duration and intensity as previously was performed. The paper bag was not adjusted absolutely air tight over the face. We aimed to regulate the pulmonary ventilation as near the normal as possible. The respiratory centre automatically showed in the graphic record whether or not this object was achieved. If the amount of fresh air leaking into the bag was excessive, a brief apnœa occurred at the end of the second hyperpnœa. If the ventilation was sub-normal, the hyperpnœa was involuntarily continued. The tube (4 cm. in diameter) was preferable for this purpose, since by varying its length (1 to 3 metres) a fairly precise regulation of the pulmonary ventilation was effected. Thus the conditions in the two experiments were precisely the same, except that in the first an excessive exhalation of  $\text{CO}_2$  occurred, while in the second this excess was prevented. The radial pulse, respiration, and time in seconds were recorded graphically before, during, and for five minutes after the periods of hyperpnœa. Examples of the tracings obtained are reproduced in Figs. 1 and 2.

In the first experiment few subjects were able without a great effort to maintain a maximum hyperpnœa for as long as two minutes. Several subjects, who at first willingly tried the experiment, refused to repeat it. In a few cases the giddiness and the peculiar "feeling of abnormality," noticed by Haldane and Poulton,<sup>16</sup> continued for a half hour or more. In a few cases (two or possibly three out of sixty subjects), apnœa did not spontaneously occur, and in such persons these subjective symptoms were especially severe. In the second experiment, on the contrary, none of the subjects experienced any marked discomfort nor any giddiness. They maintained with little effort a more nearly maximal amplitude of respiratory movement than they were usually able to do in the first experiment. They ceased their efforts merely because they were told that the period was complete.

Excluding a few exceptional cases among the sixty men examined,

<sup>16</sup> HALDANE and POULTON: *Loc. cit.*

our records show that after forced breathing for forty-five seconds apnoea lasted for a minimum of fifteen seconds and a maximum of thirty-five with an average for all of twenty-four seconds. The shorter periods were due to the subjects' maintaining the hyperpnœa merely with the

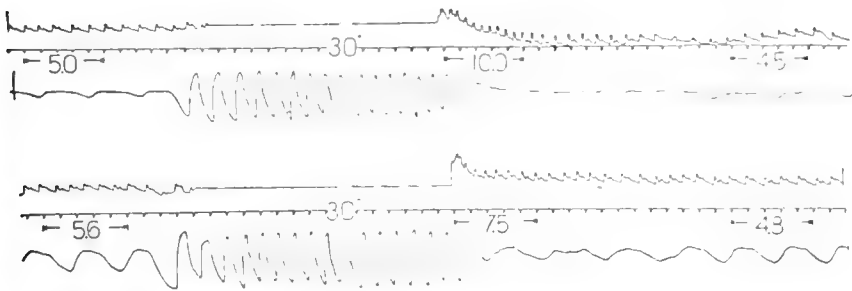

FIGURES 1 and 2. — About two sevenths the original size. Showing the effects of forced breathing of fresh air for forty-five seconds (Fig. 1), and of an equal period of voluntary hyperpnœa through a tube 4 cm. in diameter and 2 metres in length (Fig. 2). To save space a period of thirty seconds has been cut out of both records. The subject (J. R. C.) was twenty-six years old and of athletic habit. The lower curve in both figures is the respiration recorded by a tambour connected with a pneumatic belt around the thorax. Note that in the preliminary periods, although the breathing was deeper in Fig. 2 than in Fig. 1, the rates were the same; that in the latter part of the hyperpnœa of Fig. 1 the subject was unable to maintain a maximal amplitude; and that an apnoea of fifteen seconds occurred after the hyperpnœa of Fig. 1, but no apnoea at all in Fig. 2. Above the respiratory curves is a time record in one second intervals. The numbers 5.0, 10.0, etc., indicate the heart beats occurring in five seconds. The pulse curves at the top of both figures were recorded by a tambour connected with a transmitting tambour fastened upon the wrist. The curves were so much distorted by the muscular exertion of hyperpnœa that, although they were recorded, they have not been reproduced for this period. Note that the forced breathing of fresh air raised the pulse from 60 per minute beforehand to a rate of 120 at the end (*i. e.*, 10 in five seconds), while an even greater muscular exertion in breathing stale air caused only an acceleration from 67 to 90 (5.6 to 7.5 beats in five seconds). Note the fall of arterial pressure during apnoea in Fig. 1, while in the corresponding period of Fig. 2 the pulse curve is slightly higher than at first. Note that at the end of apnoea in Fig. 1 the re-accumulation of CO<sub>2</sub> in the blood acts upon the respiratory and cardio-inhibitory centres so that the heart rate drops again to the normal simultaneously with the first inspiration. The recovery of arterial pressure is much slower.

costal muscles, and failing to keep the diaphragm also at work. In all cases in which the breathing was forced to the utmost for periods of forty-five to one hundred and twenty seconds, the succeeding apnoea lasted for a half to two thirds as long as the hyperpnœa by which it was

induced. On the other hand, when the subject performed the hyperpnœa with the bag or mask over the face, there was either no apnœa at all or a pause of only two to four seconds. If the bag fitted a little too closely or the tube to the mask was too long, not only did the breathing continue without a break, but the subjects were totally unable, try as they might, to inhibit voluntarily a single breath.

The heart rates, when the subjects were lying quietly before the first hyperpnœa, ranged from 55 to 75 beats per minute, and immediately before the second experiment were usually only 4 to 8 beats per minute more rapid. At the end of the first period of forced breathing the hearts beat 10 to 12 times in five seconds (*i. e.*, at rates of 120 to 144 per minute), averaging an acceleration of 110 per cent. After the hyperpnœa with the bag, or mask and tube, over the face, they beat only 7 to 9 times in five seconds (*i. e.*, at rates of 84 to 108 per minute) with an average acceleration for the whole series of observations of only 50 per cent. If the two experiments were performed in reversed order, the difference was even greater. Thus, if we assume that in the two experiments the cardiac nerve centres were influenced to the same degree by "sympathy" with the excitement of the respiratory centre, we must conclude that more than half of the acceleration of the heart rate after voluntary excessive pulmonary ventilation is due to the direct action of acapnia on the cardiac centres or upon the heart itself.

During apnœa the heart rate fell rapidly. When it had dropped to, or a little below, the normal, the subject automatically recommenced breathing. This adjustment is so precise that an observer with his finger upon the pulse can tell to within a couple of seconds the instant at which the first spontaneous inspiration will occur. This observation places in striking accordance the demonstration of Haldane and Priestley<sup>17</sup> that apnœa vera after a brief hyperpnœa terminates when the CO<sub>2</sub> content of the blood has again accumulated up to the threshold exciting value of the respiratory centre, and our theory of the potency of this hormone in the regulation of the heart rate. In the first paper of this series we concluded from experiments on dogs, in which the heart rate was regulated by means of artificial respiration, that "in the absence of respiratory excitement the heart rate is an index which varies inversely as the CO<sub>2</sub> content of the arterial blood." We are collecting

<sup>17</sup> HALDANE and PRIESTLEY: *Loc. cit.*

evidence that when a physician counts the pulse he determines the degree of acapnia in his patient.<sup>18</sup>

During the exertion of the periods of forced breathing in both experiments a rise of arterial pressure of 20 or 30 mm. of mercury commonly occurred. It was measured by means of a Riva Rocci sphygmomanometer with a wide cuff. During the apnoea of the first experiment there was in some cases (one in every six or seven men examined) a fall of pressure to 10 or 15 mm. below the normal observed prior to hyperpnoea. It lasted longer than the apnoea and tachycardia. It is shown qualitatively in Fig. 2. The fall never occurred after forced breathing into the bag or through the tube. The ordinary arterial pressure of 30 of the men used in these experiments is between 105 and 118 mm. of mercury. Two of the three exceptional persons (p. 316) who did not pass into apnoea after forced breathing have pressures during rest of 145 and 155 mm. of mercury respectively. Apparently arterial hypertension opposes apnoea.

The influence of forced breathing upon the knee jerk was studied upon twenty-five men. The reaction was recorded by Lombard's<sup>19</sup> method. The motor efforts of the subjects influenced the kick to such a degree that the effects of acapnia were not in some cases at all easy to analyze. As a whole, the results obtained were less concordant than our observations upon respiration and the heart rate. It is noteworthy, however, that in seven cases the knee jerk was abolished or barely perceptible from the beginning of apnoea up nearly to the point at which breathing recommenced, while in the corresponding period after forced breathing into the bag the reaction was not less, and in some cases was even more than normal. The graphic records of one of these experiments is reproduced in Fig. 3.

Several of the subjects after vigorous hyperpnoea for one to two minutes experienced in varying degrees the phenomenon mentioned by Vernon.<sup>20</sup> He found that before the completion of the period of forced breathing his hands passed into a condition of tonic rigidity, and during the greater part of the apnoea were completely paralyzed. We have

<sup>18</sup> Fever involves acapnia. WESELKIN finds that in animals in fever an atmosphere of 5 to 10 per cent CO<sub>2</sub> restores the normal temperature: *Russki Wratsch*, 1907, vi, no. 14, and *Biophysikalisches Centralblatt*, 1907, iii, p. 152.

<sup>19</sup> LOMBARD, W. P.: *Laboratory work in physiology*, 1906, p. 118.

<sup>20</sup> VERNON: *Journal of physiology*, 1909, xxxviii, p. xx.

frequently observed the trembling of the muscles noted by Bornstein and Ott.<sup>21</sup> Even more common in our experience is a prickling sensation in the legs or arms, or in some cases in the entire body and face, somewhat similar to a foot or hand "asleep." One of the three exceptional men already mentioned as not passing into apnoea after forced

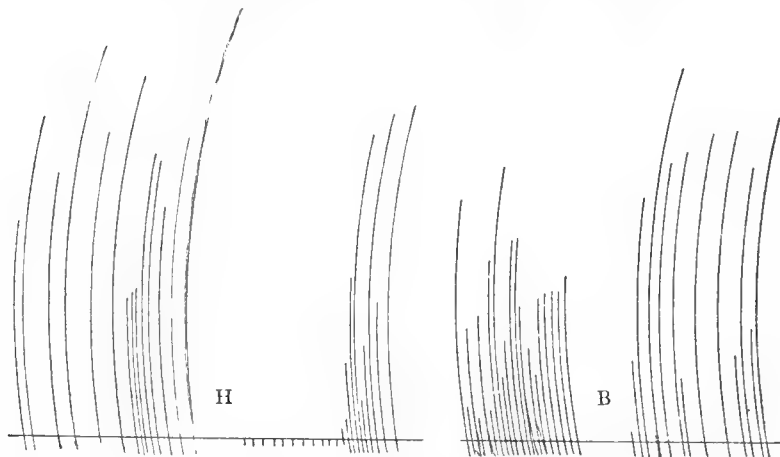

FIGURE 3. — About two thirds the original size. Record of the extent of the knee jerks elicited by the falling of a hammer through a uniform distance upon the patellar tendon. These stimuli were applied at intervals of three seconds. The first 14 kicks were obtained under normal conditions. Then the stimuli were stopped while the subject performed forced breathing (at *H*) for forty-five seconds. An apnoea of eighteen seconds followed during and after which 11 stimuli (indicated by short down strokes in the record) elicited no response. Then the reflex returned. After fifteen minutes the experiment was repeated with the difference that a small paper bag was held over the nose and mouth during the forced breathing (at *B*). No apnoea followed, and as the record shows the kicks were in most cases increased in strength.

breathing afforded the following peculiar observation. After a hyperpnoea of maximal vigor for two minutes a "shivering fit" came on, similar to that seen in a chill, and involving apparently all the muscles. While the subject was breathing spontaneously and regularly, at the time when most men are in apnoea, the knee jerk was recorded. Each time that the fall of the hammer upon the patellar tendon corresponded with the beginning of an inspiration, the depth and force of the inspiration were greatly increased. It was similar to a deep sob or gasp. The subject is a strong and healthy man of rather phlegmatic disposition. His ordinary arterial pressure during rest is 120 mm. of mercury.

<sup>21</sup> BORNSTEIN and OTT: *Archiv für die gesammte Physiologie*, 1905, cix, p. 629.



The observations of Haldane and Poulton<sup>22</sup> upon apnœa vera are strikingly in accord with the acapnial hypothesis of shock. They report that "when forced respiration is continued for a longer period (two and a half minutes for Poulton), the apnœa lasts much longer, and the oxygen percentage in the alveolar air falls to such an extent that for a considerable time before the cessation of the apnœa the subject is blue in the face, and presents a most alarming appearance, although he feels no desire to breathe. When this experiment was shown for the first time at a meeting of the British Physiological Society, some of those present thought that something was wrong with the subject of them, and could hardly be hindered from performing artificial respiration. One or two were so much affected that they became faint or sick and had to retire hastily. The face gradually assumes the leaden corpse-like appearance characteristic of great anoxhæmia, and it may be about a minute after this change begins (the duration of apnœa in Poulton was altogether a little over two minutes) before any desire to breathe is experienced."

### III. FATAL APNŒA AFTER ARTIFICIAL RESPIRATION.

It has long been known that a period of excessive artificial respiration induces failure of the circulation and respiration. Ewald,<sup>23</sup> working in Pflüger's laboratory in 1872, found that, after the vigorous use for twenty to thirty minutes of a large bellows connected with the trachea of dogs, the animals passed into prolonged apnœa, and did not recover a normal CO<sub>2</sub> content in the arterial blood for more than an hour. Arterial pressure was greatly reduced, — in one experiment from 154 down to 65 mm. of mercury. The extent to which CO<sub>2</sub> was ventilated not only out of the pulmonary air and arterial blood, but out of the tissues of the body, was shown by analyses in which only 15 to 18 volumes per cent of the gas (about a third of the normal content) were obtained from the venous blood.

Mosso<sup>24</sup> has repeated these experiments with an improvement in the respiration apparatus in which, by the use of a three-way valve, the tra-

<sup>22</sup> HALDANE and POULTON: *Loc. cit.*

<sup>23</sup> EWALD: *Archiv für die gesammte Physiologie*, 1873, vii, p. 580.

<sup>24</sup> MOSSO, A.: *Archives italiennes de biologie*, 1904, xlii, p. 192, and 1905, xliii, p. 216.

chea was connected in rapid alternation with two tanks, — one containing compressed air and the other a partial vacuum. Mosso concluded that the fall of arterial pressure, rapid heart rate, and cessation of spontaneous respiration were not the results of mechanical alterations in the pulmonary circulation, nor of reflex influences through the pulmonary vagi, but that they were due to the excessive ventilation of  $\text{CO}_2$  out of the blood.

Durdufi<sup>25</sup> noticed that a condition of shock sometimes developed in animals which were curarized and maintained under artificial respiration. He explained this by the production of acapnia, and found that it was curable by a period of partial asphyxia. He supposed, mistakenly as we believe, that acapnia induces shock by diminishing the formation of adrenalin.

In the first two experiments in which we administered artificial hyperpnœa to dogs we employed a large hand bellows. Both failed. The operator of the bellows was tired in ten minutes, while the animals, if the ventilation was then stopped, exhibited only a brief period of apnœa and an inconsiderable fall of arterial pressure. The reason for this lies in the fact that when, as in these experiments, the thorax has not been opened, the elastic recoil of the lungs and thoracic walls produces only a slow expiration. The rate of ventilation which can be achieved by mere injection of air is thus limited. The negative result of these experiments, when compared with those next to be considered, demonstrates conclusively that the effects of ventilation in the latter are due solely to loss of  $\text{CO}_2$ , and are not to be explained by mechanical interference with the thoracic circulation on the analogy of Valsalva's experiment, as Hill and Flack<sup>26</sup> have suggested.

In our experiments the apparatus shown in Fig. 4 was employed. It consists of two automobile tire pumps, one of which forces air into the trachea when the united plungers are pushed down, while the other withdraws the air when they are pulled out. These operations are further controlled by a three-way valve which is operated by the friction of a sleeve through which slides a rod fastened to the plungers. The stroke of the plungers can be adjusted to any desired length, so as not to over-distend or too greatly collapse the thorax. The apparatus is driven by a half horse power electric motor.

<sup>25</sup> DURDUFI, G. N.: *Archiv für experimentelle Pathologie und Pharmakologie*, 1900, xliii, p. 115.

<sup>26</sup> HILL and FLACK: *Journal of physiology*, 1908, xxxvii, p. 86.

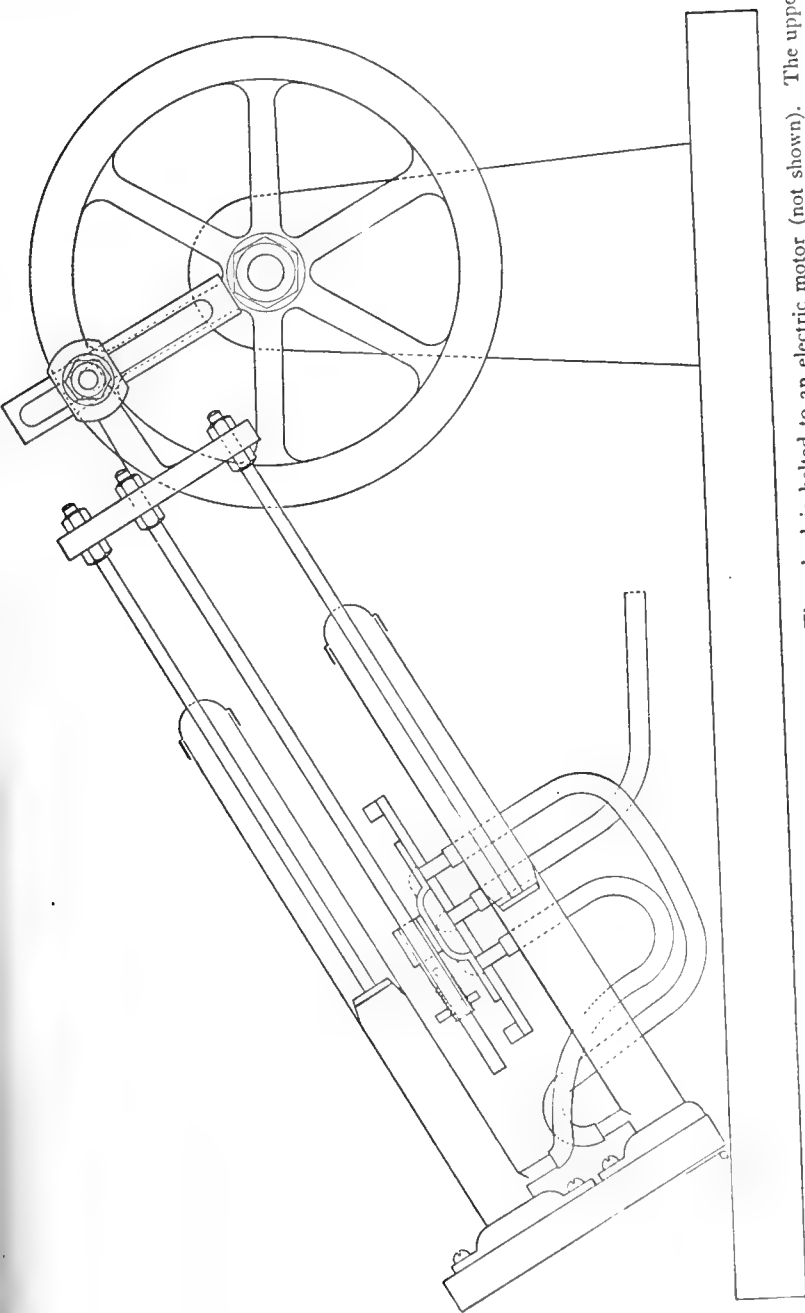

FIGURE 4. — Apparatus for producing excessive artificial respiration. The wheel is belted to an electric motor (not shown). The upper of the two automatic pumps forces air out, while the lower sucks air in because the washer on its plunger is reversed. The valve is operated by a sliding rod fastened to the plungers, and alternately connects the suction pump and force pump with the tube which leads away to the trachea.

In experiments upon three dogs the rate of artificial hyperpnœa was 120 per minute, and its duration ten to twelve minutes. A tracing of the arterial pressure, inscribed by a Hürthle manometer connected with the carotid artery, from one of these experiments is reproduced in Fig. 5. In Table I are given an abbreviated statement of the respiration, the

TABLE I.  
EXPERIMENT OF MAY 26, 1906. (See Fig. 5.)

Time.	Arterial blood gases. Volumes per cent.		Heart rate per minute.	Arterial pressure mm. of Hg.	Remarks.
	O <sub>2</sub>	CO <sub>2</sub>			
12.00	20.0	49.9	60	110	Profound anæsthesia.
12.30	20.3	33.5	116	110	Tracheotomized at 12.20.
12.45	...	...	200	120	Ether excitement.
12.50	21.8	21.8	225	60	Artificial hyperpnœa 120 strokes per minute from 12.44 to 12.55.
12.55	22.0	17.8	240	30	Apnœa. Pumps disconnected from trachea.
1.00	5.1	19.4	200	75	Apnœa. Art'l resp. by compress- ing thorax 4 or 5 times per min.
1.02	...	...	78	95	Apnœa.
1.03	...	...	180	100	Spontaneous respiration.
1.10	21.3	25.8	200	88	Shallow respiration.

numerical data of arterial pressure and heart rate, and the results of analyses (by means of a Hill<sup>27</sup> pump) of the gases of the blood drawn from the femoral artery. These data show that at first with the animal in profound morphin-ether anæsthesia the CO<sub>2</sub> content of the arterial blood was 49.9 volumes per cent, that after ten minutes of tracheotomy and ether excitement it was 33.5, and that at the end of eleven minutes of artificial hyperpnœa with the pumps it was reduced to 17.8. The heart rate was accelerated from 60 up to 240 beats per minute, and arterial pressure fell from 110 down to 30 mm. of mercury. This fall is probably to be explained, as was shown in somewhat similar experiments in the first paper of this series, by diminished venous pressure and

<sup>27</sup> HILL, L.: Journal of physiology, 1895, xvii, p. 353.

a condition of cardiac tetanus, or extreme tonus, interfering with the diastolic filling of the heart. Boise<sup>28</sup> holds that this contraction of the heart is the essential element in traumatic shock in human beings. It appears to us improbable that such is usually, although it may be rarely, the case. We believe that cardiac tetanus plays little part in any other of our experiments than those here immediately under discussion and those in the previous paper above referred to. Lowered venous pressure is the essential element.

After the artificial respiration was ended the animals made no spontaneous effort to breathe for periods of six to eight minutes. During this time the thorax was compressed by hand 4 or 5 times a minute to prevent asphyxia. The arterial blood turned a dark venous color. Owing to this anoxhæmia, a condition of asphyxial acidosis must have developed. For spontaneous respiration recommenced while the CO<sub>2</sub> content of the blood was still far below normal, — in one case 25.8 per cent and in another 23.0.

In experiments upon nine dogs the double pump was run at a rate of 60 respirations per minute for periods of twenty-five to thirty minutes. The fall of arterial pressure was not so great as in the previous experiments and was probably due to low venous pressure. The heart rates were accelerated to 220 or 250 per minute. After the pump was disconnected from the trachea five of the animals were left entirely undisturbed to die in apnœa, or to recover unaided. Two died. The graphic record of the respiration and the arterial pressure pulse of one of these

<sup>28</sup> BOISE, E.: Transactions of the American Gynecological Society, 1908, p. 7, and American journal of obstetrics, 1907, lv, p. 1.

<sup>29</sup> For the effects of more prolonged and intense artificial ventilation see the first paper of this series, *Loc. cit.*

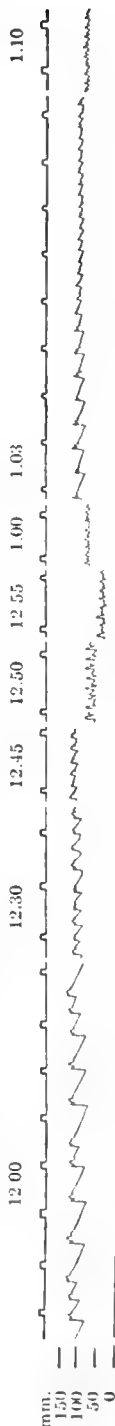

FIGURE 5. — About one half the original size. Experiment of May 26, 1906. Dog of 6.0 kilos. Morphine and ether. Operations were limited to tracheotomy, connection of Hürthle manometer with carotid, withdrawal of blood samples from femoral artery, and artificial hyperpnœa with apparatus of Fig. 4. Time in one and five tenths seconds. The record of the arterial pressure pulse here reproduced shows the fall induced by eleven minutes of excessive artificial respiration. See Table I.

subjects is reproduced in Fig. 6. The gases of the arterial blood were determined by the method of Barcroft and Haldane.<sup>30</sup> These analytical data are contained in Table II.

TABLE II.  
EXPERIMENT OF JULY 2, 1909. (See Fig. 6.)

Experiment.	Arterial blood gases.	
	Volumes per cent.	
At the beginning of the experiment . . . . .	14.8 O <sub>2</sub>	43.4 CO <sub>2</sub>
At the end of thirty minutes of artificial hyperpnœa . . . . .	15.0 O <sub>2</sub>	16.2 CO <sub>2</sub>
At death after eight minutes of apnœa . . . . .	0.0 O <sub>2</sub>	21.7 CO <sub>2</sub>

In the other fatal case the conditions and results were the same as those just described, except that after three minutes of apnœa the animal gave a deep gasp which was repeated every fifty to ninety seconds for twenty minutes. Then the heart failed in the same manner as is shown in Fig. 6. The gases of the arterial blood and other data are given in Table III.

TABLE III.  
EXPERIMENT OF JUNE 24, 1909.

Experiment. <sup>1</sup>	Arterial blood gases.	
	Volumes per cent.	
At the beginning of the experiment . . . . .	14.3 O <sub>2</sub>	39.6 CO <sub>2</sub>
After the first gasp . . . . .	8.8 O <sub>2</sub>	22.3 CO <sub>2</sub>
At death twenty minutes later . . . . .	0.0 O <sub>2</sub>	32.3 CO <sub>2</sub>

<sup>1</sup> Artificial hyperpnœa for thirty minutes, and apnœa for three minutes followed by isolated gasps and apnœas of fifty to ninety seconds until death.

In three experiments the artificial hyperpnœa was continued for only twenty-five minutes, and all three of the dogs recovered spontaneously after periods of apnœa of three, three and five tenths, and four and five tenths minutes respectively. In the last-mentioned case the heart was, however, beginning to fail when the first gasp occurred, but quickly recovered with the renewal of its oxygen supply. The graphic record of the case of three and five tenths minutes apnœa is reproduced in Fig. 7. It exhibits the isolated gasps which in many experiments interrupted apnœa. The "all or none" character of such asphyxial gasps

<sup>30</sup> BARCROFT and HALDANE: *Journal of physiology*, 1902, xxviii, p. 234. The flasks used by us were three times as large as those of BARCROFT and HALDANE, and the blood samples were 3.0 c.c. instead of 1.0 c.c.

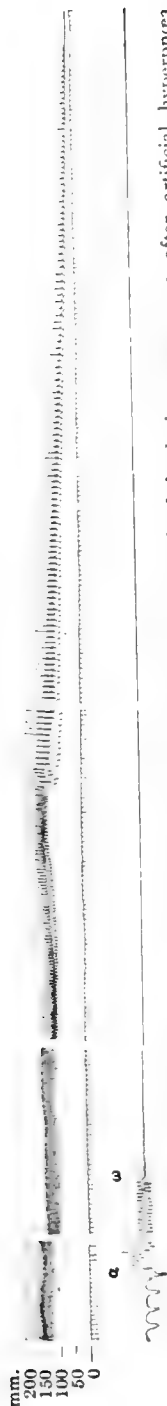

FIGURE 6. — About one third the original size. Experiment of July 2, 1909. Record of death in apnoea vera after artificial hyperpnoea. Dog under morphin sulphate (0.01 gm. per kilo) and ether. Arterial pressure recorded by Hürthle manometer connected with the carotid. Time in seconds. Respiration recorded by the method shown in Fig. 10. The first three breaths recorded were natural. Then artificial respiration with double pump for thirty minutes, — from *a* to  $\omega$ . Thereafter apnoea until the heart failed from lack of oxygen eight minutes later. At the three breaks in the curves the record is omitted for thirty, three, and one and two tenths minutes respectively. For blood gas analyses see Table II.

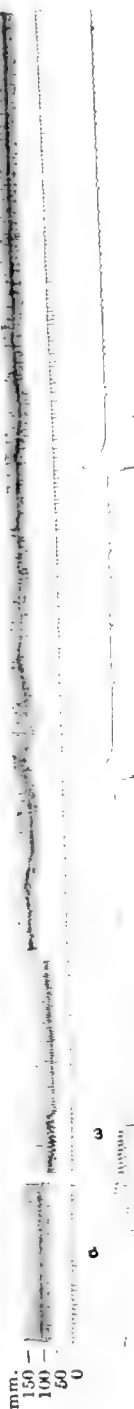

FIGURE 7. — About one third the original size. Experiment of July 7, 1909. Record of artificial hyperpnoea and apnoea vera of less than fatal duration. Dog under morphin sulphate (0.01 gm. per kilo) and ether. Same methods of recording as in Fig. 6. The curves show twelve natural breaths; artificial respiration with double pump for twenty minutes from *a* to  $\omega$ ; apnoea for three and five tenths minutes; a deep inspiratory gasp (with no active expiration); apnoea for five tenths of a minute; periodic breathing; and gradual return to normal breathing. Arterial pressure and the heart were relatively little influenced. At the breaks in the curves the record is omitted for twenty, and two and five tenths minutes respectively. For blood gas analyses see Table IV.

has never, so far as we are aware, received adequate explanation.<sup>31</sup> The record shows also the periodic or Cheyne-Stokes respiration which generally preceded the return of normal breathing. Here (Fig. 7) the breaths occur first in pairs at intervals of ten seconds; then by threes; then four full and two subnormal breaths; and so on, until the return of a uniform rhythm.

Haldane and Douglas<sup>32</sup> have explained periodic breathing after forced respiration in man by assuming that during apnoea organic acids accumulate in the blood, and that these substances (added to the carbonic acid) excite the respiratory centre to more or less excessive effort. In the presence of the oxygen provided by the deep inspirations thus excited the asphyxial acids are decomposed, and the respiratory centre relapses into subnormal activity until they re-accumulate. The Cheyne-Stokes breathing observable in our experiments is readily explicable in accord with the view of Haldane and Douglas. It is probable that some of the asphyxial substances (*e. g.*, oxybutyric acid) are less readily oxidized than others (*e. g.* lactic acid). The occurrence of spontaneous breathing at a time when the blood contains much less than its normal quantity of CO<sub>2</sub> indicates acidosis. This condition always occurred at the return of respiration after prolonged apnoea. In the experiment from which Fig. 7 is taken the arterial blood gases were as shown in Table IV.

TABLE IV.  
EXPERIMENT OF JULY 7, 1909. (See Fig. 7.)

Experiment. <sup>1</sup>	Arterial blood gases. Volumes per cent.	
At the beginning of the experiment . . . . .	16.0 O <sub>2</sub>	40.1 CO <sub>2</sub>
After the return of spontaneous breathing . . . . .	13.4 O <sub>2</sub>	28.9 CO <sub>2</sub>

<sup>1</sup> Artificial hyperpnoea for twenty-five minutes, and apnoea for three minutes followed by gasps and Cheyne-Stokes breathing.

Vernon<sup>33</sup> has reported experiments upon himself in which, after forced breathing for six minutes ending with 4 deep inspirations of

<sup>31</sup> Such gasps occur at death from hæmorrhage and after violent laughter or weeping. We saw them in the man referred to on p. 320. We have seen them in a dog in ether excitement, the deep gasps at intervals of fifty seconds punctuating the hyperpnoea.

<sup>32</sup> HALDANE and DOUGLAS: *Journal of physiology*, 1909, xxxviii, pp. 401 and 420.

<sup>33</sup> VERNON: *Loc. cit.* A careful study of the summation of asphyxial acidosis, with the CO<sub>2</sub> remaining in the blood, in stimulating the respiratory centre has been published from DURIG's laboratory since this paper was written. LEINDÖRFER, A.; *Biochemische Zeitschrift*, 1909, xxii, p. 45.



oxygen, he held his breath for the period of eight minutes and thirteen seconds. After forced breathing without oxygen he could hold it for only four minutes. Without forced breathing the breaking point was reached in forty-two seconds. Two of our experiments afford a similar confirmation of the view that asphyxial acidosis is a factor in the return of respiration, before the CO<sub>2</sub> content in the blood has accumulated up to its normal quantity. These experiments were similar to those above described, except that at the beginning of apnoea a soft rubber catheter, connected with a tank of oxygen gas, was inserted in the trachea down to the bifurcation of the bronchi. During the apnoea a gentle stream of the gas was maintained. It has been shown by Volhard<sup>34</sup> that the blood is amply supplied with oxygen by this method even during complete respiratory standstill, but that there is little or no removal of CO<sub>2</sub> with a mild flow. For our purpose the method afforded almost ideal conditions for re-accumulation of CO<sub>2</sub> without the complication of acidosis. In both of the cases in which oxygen was thus supplied during apnoea, the duration of apnoea was longer, and the quantity of CO<sub>2</sub> in the blood when breathing recommenced was larger, than was the case when anoxaemia occurred. This is essentially the same condition as the "oxygen apnoea" described by Mosso.<sup>35</sup> Moreover, Cheyne-Stokes periodicity did not appear. In the most successful of these experiments graphic records were obtained altogether similar to Fig. 7, except in the feature just mentioned, and except that the second break in the curves would be nearly twelve minutes instead of only three. The arterial blood gases and the duration of hyperpnoea and of apnoea are shown in Table V.

TABLE V.

EXPERIMENT OF JULY 1, 1909.

Experiment. <sup>1</sup>	Arterial blood gases.	
	Volumes per cent.	
At the beginning of the experiment . . . . .	17.0 O <sub>2</sub>	49.0 CO <sub>2</sub>
At the recommencement of spontaneous breathing . . . . .	18.6 O <sub>2</sub>	47.3 CO <sub>2</sub>

<sup>1</sup> Artificial hyperpnoea for twenty-five minutes and apnoea for twelve minutes, during which a jet of oxygen was blown into the bronchi; then spontaneous normal breathing.

<sup>34</sup> VOLHARD: Münchener medizinische Wochenschrift, 1908, no. 5; see also MELTZER and AUER: Zentrallblatt für Physiologie, 1909, xxiii, pp. 210 and 442; and BIEDL and ROTHBERGER, *Ibid.*, p. 327.

<sup>35</sup> MOSSO, A.: Archives italiennes de biologie, 1904, xli, p. 138.

In three experiments additional evidence was obtained that apnœa vera is due to acapnia. The dogs were treated precisely as heretofore, except that after the first minute of apnœa a catheter connected with a CO<sub>2</sub> generator was inserted in the trachea down to the bifurcation of the bronchi, and a gentle stream of the gas was turned on. Almost immediately the animals began to breathe. After half a minute the gas was turned off, and they relapsed into apnœa. One of the records obtained is reproduced in Fig. 8.



FIGURE 8. — About one third the original size. Record of natural breathing induced by passing a small amount of CO<sub>2</sub> gas into the bronchi of a dog in apnœa vera. The animal had been under artificial hyperpnœa for twenty-five minutes and in apnœa for one minute when the CO<sub>2</sub> was turned on (at α). Note the relapse into apnœa after the gas was turned off (at ω). Arterial pressure was uniform throughout at 150 mm. of Hg.

As all of the subjects of these experiments were drugged, it is necessary to consider briefly the influence of anæsthesia upon the respiratory centre. It is generally believed, and our experience confirms the belief, that profound anæsthesia lowers the sensitivity of the centre. In this condition the centre automatically maintains more than the normal quantity of CO<sub>2</sub> in the blood, and might become apnœic when the quantity was such as would normally induce activity. The blood gas analyses at the beginning of most of our experiments indicate that with the dosage of morphin which we have employed and with adequate but not excessive etherization, the "threshold" of the centre for CO<sub>2</sub> is not much higher than normally. On the other hand, we have often found dogs which in moderate ether anæsthesia were almost incapable of apnœa, and were continuously and vigorously hyperpnœic even when their blood contained less than 20 volumes per cent of CO<sub>2</sub>. This exception to the Miescher-Haldane conception is of the greatest importance both theoretically and practically. In a later paper of this series we plan to consider it more fully. After nearly four years of perplexity over our experimental failures, it has become clear that, at the end of a period of excessive pulmonary ventilation, enough ether (or chloroform) must be administered to produce the third stage of anæsthesia, if apnœa is to be

obtained. Prolonged apnoea always occurs when these conditions are fulfilled. In all the experiments above reported sufficient ether was

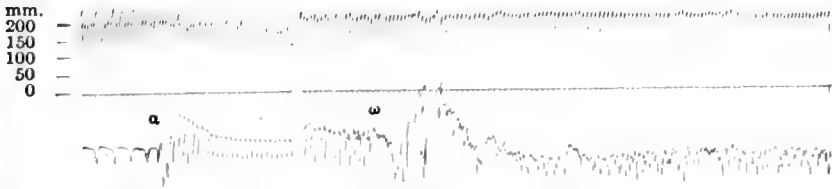

FIGURE 9. — Experiment of June 19, 1909. Record of artificial hyperpnœa with no apnoea following because the subject developed ether excitement. Dog under morphin (0.005 gm. per kilo) and light ether anæsthesia. No ether during ventilation. Same methods of recording as in Fig. 6. At the break in the curves the record is omitted for twenty-four minutes. Four natural breaths. From  $\alpha$  to  $\omega$  artificial hyperpnœa with double pump for twenty-five minutes. Immediately after the pump was disconnected from the trachea spontaneous breathing recommenced. Note the violent shivering of the animal shown in the respiratory curve.

added to the air supplied to the lungs by the double pumps during the last half dozen strokes to induce the third degree of anæsthesia. When

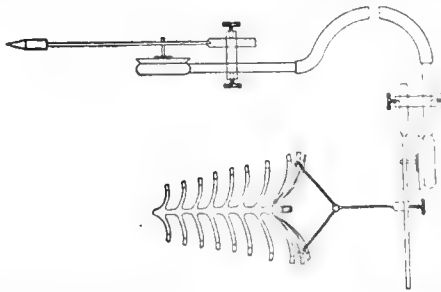

FIGURE 10. — One third the original size. Method of recording respiration. Hooks were inserted under the last complete rib on each side, and were connected by three chains and a ring with the lever of a transmitting tambour, from which a rubber tube led to a recording tambour. A rubber band (not shown) was attached to the lever and drew the chains taut. Curves thus recorded are not quantitative as to the relative volume of diaphragmatic and costal breathing. Contractions of the diaphragm always caused the tambour to record, but relatively much less than the movements of the ribs. After a trial of many methods, this alone proved satisfactory for the special conditions of these researches.

only light anæsthesia was induced the results were such as those illustrated in Fig. 9. The dog from which this record was obtained shivered violently and breathed vigorously, although totally unconscious, when it should have been in apnoea after twenty-five minutes of artificial

hyperpnœa.<sup>36</sup> A few minutes later more ether was administered. Apnœa vera then set in and lasted until death.

These statements lay our experiments open to the charge that we have merely killed the animals with ether. Such was not the case, however, for the quantity of ether was too small to paralyze respiration under ordinary circumstances. Tests of the animals' reflexes during apnœa showed that the narcosis was not deeper than ordinary surgical anæsthesia. Furthermore our data as a whole indicate, we believe, that the majority of all the animals and men who die under ether are not killed by the drug, strictly speaking, but pass naturally into apnœa vera when the threshold of the respiratory centre for CO<sub>2</sub> is raised to its normal level. The so-called failure of respiration is caused by the acapnia previously induced by emotion, by pain, or by ether-excitement.

The method of recording respiration in these experiments is shown in Fig. 10.

#### CONCLUSIONS.

Voluntarily forced breathing in man, so far as the experiment can be safely carried, induces symptoms similar to those of shock. Death from failure of respiration would probably result from vigorous voluntary hyperpnœa for fifteen or twenty minutes. Pain, ether-excitement, sorrow, fear, and other conditions inducing shock, involve excessive respiration.

Excessive artificial respiration, applied to dogs for twenty-five to thirty minutes, is followed by apnœa so prolonged that the heart fails, after seven to eight minutes, for lack of oxygen. The inactivity of the respiratory centre is solely due to the depletion of the body's store of CO<sub>2</sub>. During the anoxhæmia after the second minute of apnœa the products of incomplete tissue combustion accumulate in the blood. If the acapnia is not too intense, this acidosis furnishes a potent aid in restoring spontaneous breathing. The alternate accumulation and oxidation of acidosis substances in the blood induce Cheyne-Stokes breathing. Administration of CO<sub>2</sub> gas during apnœa induces an immediate return of natural breathing. Administration of oxygen by the Volhard method affords ideal conditions for recovery from acapnia, and prevention of asphyxial acidosis.

<sup>36</sup> Compare the observations on a man on pp. 319 and 320.

Deep anæsthesia diminishes the sensitiveness of the respiratory centre to the influence of  $\text{CO}_2$ , so that a subject which has previously developed acapnia inevitably ceases to breathe as soon as the third stage of anæsthesia is induced. In any less quantity, however, ether tends to prevent apnœa, unless its influence as a "respiratory stimulant" is neutralized by morphin.

In the next paper of this series failure of respiration after intense pain will be shown to be apnœa vera identical with that here discussed.

# THE EFFECT OF SEVERING THE VAGI OR THE SPLANCHNICS OR BOTH UPON GASTRIC MOTILITY IN RABBITS.<sup>1</sup>

By JOHN AUER.

[From the Department of Physiology and Pharmacology of the Rockefeller Institute and from the Physiological Laboratory of the Harvard Medical School.]

IN order to study the motor phenomena of the stomach after its partial or complete isolation from the central nervous system, a method was employed which the writer has used for observation of normal gastric movements in rabbits.<sup>2</sup> This method is very simple: after being fed, the rabbit is stretched out on a holder, the hair over the epigastrium clipped, and this area observed.<sup>3</sup> This simple procedure gives trustworthy data regarding the motility of the stomach in rabbits. Cannon has recently studied the same subject,<sup>4</sup> but the results of his research do not render this report superfluous, for both the methods and animals utilized are different, Cannon using the Röntgen-rays-bismuth procedure on cats exclusively. It may be stated at the outset that the main results of Cannon regarding the motor activities of the stomach under the conditions indicated were observed in rabbits also.

## OPERATIVE METHODS.

The rabbits were always fed for about two hours before operation, the feeding time being preceded by a period of starvation. If, after feeding, the animals showed a soft and poorly filled stomach on palpation, it was rejected, for the object was to have gastric peristalsis

<sup>1</sup> Owing to the press of other work, these observations have not been published sooner, though they have been completed for practically two years. A preliminary report was published in the Proceedings of the Society for Experimental Biology and Medicine, 1908, v, p. 30.

<sup>2</sup> AUER: This journal, 1907, xviii, p. 347.

<sup>3</sup> For details, see AUER: *Loc. cit.*, and AUER: This journal, 1908, xxiii, p. 165.

<sup>4</sup> CANNON: This journal, December, 1906, xvii, p. 429.\*

well established at the time of operation, and for this a well-filled stomach is usually necessary.<sup>5</sup> The operations were usually performed under aseptic precautions.

Vagus influence upon the stomach was ruled out by three methods: (a) the nerves were both cut in the neck; (b) the left vagus was cut in the neck and the right just below the origin of the recurrent nerve of that side, so as to preserve a partial motor innervation of the larynx; this method was used by Cannon;<sup>6</sup> (c) or the vagi were resected or cut below the diaphragm. This last method was employed exclusively in my late work. The operation is simple, and one to two centimetres of the two vagus trunks may be resected with ease.<sup>7</sup>

The splanchnic nerves were cut or torn after laparotomy, the intestines being pushed aside by sterile gauze soaked in hot salt solution. Resection of a piece of the nerves was done whenever practicable. The operation is at times quite difficult on the right side, and laceration of the liver or pneumothorax may easily be produced.

The abdominal incision was usually in the linea alba. Transverse incisions across the epigastrium did not yield good results in my hands; the wound as a rule did not heal properly, and areas of necrosis appeared.

The wound was sutured in layers with cotton thread. Only two rabbits out of the entire series developed a hernia; stitch abscesses occurred now and then. No bandages whatsoever were used, nor were the wounds covered with collodion.

The anesthetic employed was ether. It deserves to be emphasized that a rabbit is by no means easily put under the influence of ether. The lid and corneal reflexes may be abolished, yet a touch upon the parietal peritoneum may cause a reflex movement.

In a few cases morphin was used in conjunction with ether. This alkaloid cannot be employed when the earliest appearance of peristalsis is to be determined, for it stops gastric movements, as I stated in 1906 in a short communication,<sup>8</sup> and Magnus has also pointed out quite recently that morphin interferes with stomach motility.<sup>9</sup>

<sup>5</sup> AUER: *Loc. cit.*, p. 255.

<sup>6</sup> CANNON: This journal, 1906, xvii, p. 430.

<sup>7</sup> VAN IZEREN: *Zeitschrift für klinische Medicin*, 1901, xliii, p. 181; OPHÜLS: *Journal of experimental medicine*, 1906, viii, p. 87.

<sup>8</sup> AUER: *Proceedings of the Society for Experimental Biology and Medicine*, 1906, iv, p. 9.

<sup>9</sup> MAGNUS: *Archiv für die gesammte Physiologie*, 1908, cxxii, p. 219.

## RESECTION OF THE VAGI.

In a few animals the vagi were both cut in the neck, but this method was discarded because it was impossible to keep the rabbits alive sufficiently long to obtain the return of normal stomach movements. In a second set the left vagus was resected, and at the same time the right vagus cut below the origin of the recurrent nerve; this is the method which Cannon employed on cats, although the two resections were made on different days by him. This method was abandoned after a few trials because the thoracic œsophagus is deprived of its innervation and that interfered with a proper filling of the rabbit's stomach. Attempts to fill the stomach with starch paste or finely ground carrots, by means of a tube, were unsatisfactory. Another method had to be employed, therefore, in order to study gastric motility in the rabbit under proper conditions. In the last series both vagi were resected beneath the diaphragm. This method proved to be the most satisfactory one, and it was now exclusively employed when the vagi were to be cut. The data given below are based on this series.

## RESULTS.

There were nine rabbits in this series and they were under observation as a rule for thirty minutes immediately after operation, before removal from the board. After removal from the board they were well covered with blankets and examined at thirty-minute intervals for four to six hours. After this, examinations were made daily after feeding, for the animals ate usually on the day following the operation.

In order to detect the first peristaltic movements on the stomach the graphic method was employed. A receiving Marey tambour was placed over the pyloric third of the stomach and connected with a registering tambour. Observation alone was not satisfactory, as it was difficult to distinguish the slow, slight movements of the pyloric third, where peristalsis always appeared first.

The first sign of peristalsis, denoted by a moderate rhythmic bulging of the pyloric third, was seen two to three hours after the operation (Fig. 1, *a*). The waves were slight and weak as a rule; in most cases they were irregular in rhythm. These indications of gastric movement



were confined to the pyloric third; no waves were seen starting in the middle third of the stomach. Normal peristalsis was usually established after one to two days, and tracings taken from the pyloric third of the stomach of these rabbits then showed no appreciable difference from those obtained from normal animals (Fig. 1, *b*). Inspection also

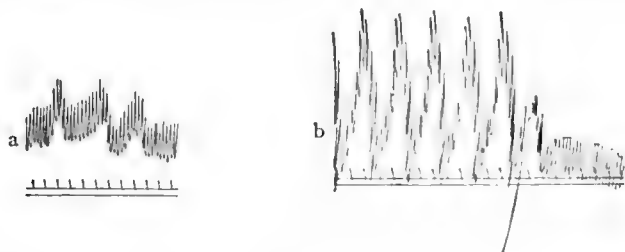

FIGURE 1. — *a*. Stomach waves obtained about five hours after the vagi had been resected beneath the diaphragm. *b*. Same rabbit. Stomach waves two days later. Note the inhibition following a sudden start of the animal. All tracings were obtained by Marey tambours from the pyloric third of the stomach. The large oscillations are stomach waves; the small waves, superimposed on the larger ones, are respirations. All time records show six-second intervals.

failed to show any difference between normal and operated animals. In one or two instances, however, the stomach did not adapt itself efficiently to its new condition in so short a time; in one instance about ten days elapsed before the gastric movements were approximately normal.

During the first twenty-four hours but little food seems to leave the stomach, for the stomach shows no noticeable diminution in size.

#### EFFECT OF REFLEXES.

The effect of sensory stimuli upon gastric peristalsis is well known. Cannon<sup>10</sup> has shown that rage, fright, etc. stop gastric movements in cats, and in another paper<sup>11</sup> I have shown that a variety of sensory stimuli may temporarily inhibit gastric peristalsis in rabbits. The most effective stimulus, which rarely fails as far as my experience goes in rabbits, is a struggle.

Sensation through the skin nerves or by means of sight, hearing, smell, may occasionally fail at one time and yet be fully or partly effectual at another time.

<sup>10</sup> CANNON: This journal, 1898, i, p. 380.

<sup>11</sup> AUER: *Loc. cit.*, p. 361.

In testing the effect of reflexes upon the stomach movement of these operated rabbits, it was found that they behaved normally, that is, sensory stimuli, struggles, abolished, as a rule, gastric movements for periods of time varying from thirty seconds to a number of minutes (Fig. 1, *b*). Usually this reflex inhibition is of short duration, lasting less than one minute; in Rabbit 9, however, a struggle always caused an inhibition lasting eight to ten minutes.

The animals stood resection of both vagi beneath the diaphragm very well, and no immediate deaths occurred. Two were found dead

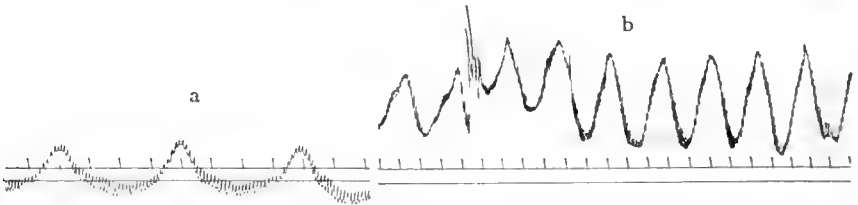

FIGURE 2. — *a*. Stomach waves obtained forty-five minutes after resection of both splanchnic nerves. *b*. Same rabbit two days later. Note that handling of the rabbit, causing a moderate struggle, does not inhibit gastric motility.

one and three months respectively after the operation; the others were killed after intervals of two to six months apparently in normal condition, though autopsy showed a number of them had gastric ulcer.<sup>12</sup>

#### THE EFFECTS OF CUTTING THE SPLANCHNIC NERVES.

There were nine rabbits in this series, and all except one showed regular but weak gastric waves thirty minutes after cutting the splanchnic nerves (Fig. 2, *a*). In some cases rhythmic bulgings of the pyloric third of the stomach were noted while the abdominal wall was being sutured. These early waves, however, were normal in only one quality, in rhythmicity; they did not originate, apparently, in the middle third of the stomach; they were confined to the pyloric third; they were weak, only one third or one fourth as strong as an average normal gastric wave.

Normal gastric waves were not seen until two to three days had elapsed after the operation (Fig. 2, *b*).

<sup>12</sup> See VAN IZEREN: *Loc. cit.*; OPHÜLS: *Loc. cit.*

## REFLEXES.

The effect of reflexes upon the motility of the stomach was interesting in these animals: the stimuli which usually caused stoppage of stomach activity now were ineffectual (Fig. 2, *b*); at most only a slight reduction in the size of a few of the waves following the stimulus occurred. This was especially true of the effects of a struggle. In these animals, whose splanchnics had been cut or resected, a struggle produced no effect on gastric movement, or at most a slight reduction in size of the waves in the pyloric third, with no interference in their rhythmicity. This inhibitory effect, when present, lasted only a short time.

## EFFECT OF THE OPERATION.

Rabbits apparently stand this operation very badly. Five died within forty-eight hours. The others were utilized after one to three weeks, and these animals looked thin and scrawny but were lively and active in their cages. These animals differed strikingly in their appearance from the well-nourished rabbits of the other two series.

## THE EFFECTS OF CUTTING VAGI AND SPLANCHNIC NERVES.

In this series of seven rabbits both vagi were resected below the diaphragm and both splanchnic nerves were severed during the same operation. The animals stood the operation well, better than in the series where the splanchnic nerves alone were cut.

The first signs of movement were noted in the pyloric third usually within thirty minutes, but no definite waves could be distinguished passing over the stomach. The bulgings of the pyloric third were rhythmical, occurring in some instances at thirty to forty second intervals; their strength, as indicated by the size of the wave, was good, though not quite normal; their duration was normal, about twelve to eighteen seconds (Fig. 3, *a*).

Normal peristalsis was not obtained until one or two days after the operation. Now gastric peristalsis showed an interesting characteristic; waves, as registered from the pyloric third, showed a definite arrangement in groups, each group, consisting of a variable number of

waves, being followed by a period of inactivity (Fig. 3, *b*). This grouping was still noted in rabbits examined three months after operation.

#### REFLEXES.

The ordinary reflexes affecting gastric peristalsis had no influence upon these animals; struggles caused no stoppage. It was quite difficult in some instances to decide whether the stimuli exerted an effect,

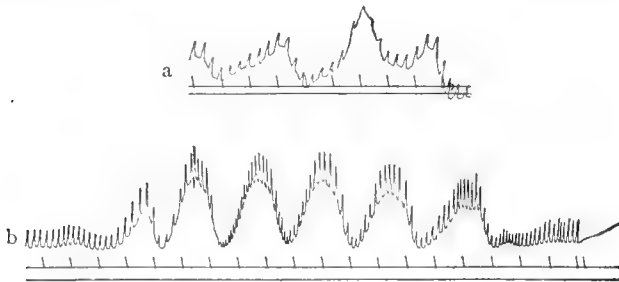

FIGURE 3.—*a*. Stomach waves obtained five hours after vagi and splanchnics both had been resected. *b*. Same rabbit three days later. Note grouping of stomach waves.

for the grouping referred to above at times simulated an inhibitory response. Careful examination justifies the statement that the stimuli exerted no effect; this was to be expected, for the stomachs of these rabbits were isolated from the central nervous system.<sup>13</sup>

#### EFFECT OF THE OPERATION.

The mortality from sectioning the splanchnic and vagi both at one sitting was considerably less than from cutting the splanchnics alone. Two died within forty-eight hours. The others were killed after one week to several months for various purposes; they looked well nourished and behaved normally.

<sup>13</sup> Strictly speaking, the stomachs of these rabbits were not entirely devoid of extrinsic innervation, though they were free from interferences from the central nervous system. The splanchnic nerves were cut, and this still left intact the post-ganglionic fibres from the cœliac ganglia. It is conceivable that this ganglion may still influence the stomach, thus serving as an independent centre.

## DISCUSSION.

From the experimental evidence given in the preceding pages it is clear that the stomach, of rabbits at least, is able to carry on its motor functions effectively when totally isolated from the central nervous system. The same is true when only one set of the extrinsic nerves, either the vagi or the splanchnics, is cut.

In spite of the fact that the stomachs of these operated animals may show apparently perfectly normal gastric motility after some time, there is enough evidence that the animals now are in a more vulnerable state. This is strikingly shown by the series of rabbits in which the splanchnic nerves were resected, where a majority of the rabbits died after forty-eight hours. The operation in itself cannot be held responsible for the death rate, for, in the series where both vagi and splanchnics were cut, the mortality was much lower, yet the operation in itself was at least just as severe as when the splanchnics alone were cut. Again, in the series where the vagi were resected, practically all of the rabbits which were killed after some months showed a gastric ulcer.<sup>14</sup> These ulcers were usually located at or just anterior to the nodular, muscular thickening on the lesser curvature side which forms part of the preantral sphincter.<sup>15</sup> In two instances the ulcer had perforated, and a pouch filled with stomach contents was found lying on the lesser curvature, yet these animals showed a gastric motility which did not differ from that of a normal animal. It seems clear, therefore, that in efficiently adapting itself to these new conditions the animal has laid itself open to probably a variety of noxious agencies.

But the local government of the stomach, in the rabbit at least, does not assume control at once (see figures). In the three series of experiments described, irrespective of whether the vagi alone, or the splanchnics alone, or both vagi and splanchnics, were cut, two to three days elapsed before the rabbit showed fully normal gastric motility on inspection of its abdomen. In some instances, especially in the series when both vagi and splanchnics were cut at the same sitting, normal gastric waves were seen after twenty-four hours. In no instance was the motility normal in rate and strength a few hours (six) after the operation. In some cases normal motility was not seen until four or

<sup>14</sup> VAN IZEREN: *Loc. cit.*; OPHÜLS, *Loc. cit.*

<sup>15</sup> AUER: This journal, 1907, xviii, p. 353; also 1908, xxiii, p. 171.

five days had passed, but these were exceptional. Two to three days may be said to be the average length of time which passed before the stomach moved normally in rate and strength.

As already stated, two or three days elapse before gastric motility in the rabbit is apparently normal in rate and strength, yet the first signs of movement occur shortly after the operation itself, depending upon the character of the operative intervention. When the splanchnics alone are cut, gastric movements were often noticeable on the pyloric third of the stomach while the abdominal wound was being sutured. These waves occurred at normal intervals, but were weak, and apparently did not arise in the middle third of the stomach (Fig. 2, *a*). After section of the vagi no movements were observed until after about two hours (Fig. 1, *a*). Now the pyloric third again was the only place where rhythmic bulgings were noticeable; there was no visible wave traversing the body of the stomach. These waves were feeble and irregular. After section of vagi and splanchnics both, the first sign of motility was again shown by the pyloric third. These bulgings were almost normal in size, but they usually occurred at abnormally long intervals. These data I wish to utilize merely to distinguish sharply between the first sign of returning motility and the establishment of normal peristalsis. The same distinction between the earliest appearance of motility and the establishment of normal waves is made by Cannon<sup>16</sup> in his similar research upon cats.

This investigation gives no direct information regarding the motor influence of the vagi upon the stomach, but there is some evidence that a moderate reflex inhibition can be produced through these nerves. It has already been stated that after the splanchnic nerves were cut, various stimuli caused at times a slight reduction in the size of the gastric waves, but never a stoppage such as is normally produced by the same stimuli. As this reduction was not observed when vagi and splanchnics both were cut, it is legitimate to assume that the inhibitory impulse was mediated through the vagi. That the vagi possess inhibitory fibres for the stomach is well known through the researches of Langley,<sup>17</sup> Meltzer,<sup>18</sup> May,<sup>19</sup> and Cannon.<sup>20</sup> On the other hand, the information

<sup>16</sup> CANNON: *Loc. cit.*, pp. 431-432.

<sup>17</sup> LANGLEY: *Journal of physiology*, 1898, xxiii, p. 407.

<sup>18</sup> MELTZER: *New York medical journal*, 1899, May 20, 27.

<sup>19</sup> MAY: *Journal of physiology*, 1904, xxxi, p. 262.

<sup>20</sup> CANNON: *American journal of the medical sciences*, 1909, p. 7 (reprint).

given by the experiments reported above is clear and unequivocal regarding the inhibitory function of the splanchnic nerves. After the section of the splanchnic nerves it was impossible to stop gastric movements by any of the stimuli which were effective when the animal was normal or when the splanchnics alone were intact (vagi resected). This corroborated fully the observation of Cannon and Murphy<sup>21</sup> that inhibition of the stomach is produced through the splanchnic nerves. These experiments, however, give no information for or against the assumption that the splanchnics also have a motor function.<sup>22</sup>

As already stated before, the main results of Cannon's research upon the motility of the stomach in the cat, a carnivore, after vagus or splanchnic section, are found to be true also for the rabbit, a herbivore. This corroboration is all the more valuable, as the method employed in rabbits is totally different from the one used by Cannon; Cannon observed the stomach by means of his well-known X-ray-bismuth procedure, while in this investigation mere inspection of the rabbits' abdomens furnished the information.

There are, however, some minor differences between Cannon's results and mine. To illustrate: after bilateral splanchnic section Cannon observed no change in the normal movement of the stomach;<sup>23</sup> in rabbits one to two days elapsed before I obtained evidence of normal gastric motility, though weak movement often began a few minutes after the operation. After section of both vagi and splanchnic, Cannon noted normal peristalsis almost from the start.<sup>24</sup> In rabbits gastric waves appeared after a few minutes, but they were by no means normal in frequency, though quite strong; under these conditions also one to two days passed before fully normal waves were seen. Cannon also mentions that cats after bilateral vagus section never appeared so vigorous as the animals with only the splanchnics cut,<sup>25</sup> also that all the animals after severance of vagi and splanchnics both were noticeably asthenic.<sup>26</sup> In rabbits bilateral section of the splanchnics alone was apparently a much severer interference than section of the vagi be-

<sup>21</sup> CANNON and MURPHY: *Journal of the American Medical Association*, 1907, p. 841.

<sup>22</sup> MORAT: *Archives de physiologie*, 1893, xxv, p. 142.

<sup>23</sup> CANNON: *Loc. cit.*, pp. 430, 431, 442.

<sup>24</sup> CANNON: *Loc. cit.*, pp. 432, 442.

<sup>25</sup> CANNON: *Loc. cit.*, p. 431.

<sup>26</sup> CANNON: *Loc. cit.*, p. 431.

neath the diaphragm, or section of vagi and splanchnics both. Section of the vagi is very well borne by rabbits; this has also been the experience of Ophüls.<sup>27</sup> These differences between Cannon's and my own results are, however, rather of minor importance and probably are due to differences in operative methods and also to differences in the animals employed.

#### SUMMARY.

1. After bilateral section of the splanchnic nerves in rabbits the stomach shows initial weak movements within thirty minutes of the operation. *Normal* peristalsis is not established until after about two days.

The effects of the operation are severe, and the majority of the animals succumb after a few days.

2. After subdiaphragmatic section of both vagi initial signs of stomach movement occur after about two hours. *Normal* peristalsis is not observed until about two days have elapsed.

Rabbits recover well from this operation and seem normal; they are, however, likely to develop gastric ulcer.

3. After section of splanchnics and vagi both, initial peristalsis is observable within less than thirty minutes; this peristalsis is, however, slow in rate though almost normal in strength. Peristalsis, normal in rate, rhythm, and strength is not noted until one to two days have passed, and now the gastric waves tend to occur in groups.

Rabbits usually recover well from this interference and appear to be normal. The mortality from this operation is less than from splanchnic section alone, and greater than that from vagus section alone; it is greater than that of normal rabbits.

4. The efficient adaptation of the rabbit to the new conditions produced by these various operations seems to entail various consequences which reduce the general resistance of the animal.

5. Complete reflex inhibition of the stomach can be obtained only when the splanchnic nerves are intact. Only a slight degree of reflex inhibition of the stomach could be obtained through the vagi.

<sup>27</sup> OPHÜLS: *Loc. cit.*, p. 184.



CONTRIBUTIONS TO THE PHYSIOLOGY OF LYMPH.—  
X. THE COMPARATIVE ELECTRICAL CONDUCTIVITY OF LYMPH AND SERUM OF THE SAME ANIMAL, AND ITS BEARING ON THEORIES OF LYMPH FORMATION.

By A. B. LUCKHARDT.

*[From the Hull Physiological Laboratory of the University of Chicago.]*

IT is still a common assumption, held by many physiologists and emphasized by those who believe in the mechanical theories of lymph formation, that the qualitative and quantitative composition of the lymph and serum is the same as far as the inorganic salts are concerned. As a matter of fact, the literature, as has been recently pointed out,<sup>1</sup> contains no data on the quantitative composition of the lymph and serum of the same animal. In addition it was pointed out that the quantitative composition of the lymphs and sera of different species of animals must be ignored, since the individual variation in the salt content of the serum of the same species of animal is so considerable that a comparison of the ash content of the lymph of one animal and the serum of another animal is of no value whatever. Parallel determinations of <sup>1</sup> the Cl content of the lymph and serum of seventeen horses and five dogs lead to the surprising fact that the lymph shows a higher per cent of Cl than does the serum. "The difference in favor of the lymph averages about 10 per cent for horse and dog." This preponderance of chlorides in the lymph over the serum presupposes a greater electrical conductivity of the lymph over the serum, assuming (1) that the quantitative distribution of the other electrolytes is the same in the two body fluids and (2) that the greater amount of proteins in the serum plays no significant rôle in depressing the electrical conductivity of the latter fluid, if such was found to be the case. The in-

<sup>1</sup> CARLSON, GREER, and LUCKHARDT: This journal, 1908, xxii, p. 91.

creased Cl content of the lymph and these considerations form the basis of the following work.<sup>2</sup>

#### METHODS.

In the study of this problem three methods were employed:

I. The direct determination of the electrical conductivity of serum, thoracic lymph, and cervical lymph of the same animal. The results of this investigation necessitated

II. A study of the effect of salt-free protein (egg-albumin) on the electrical conductivity of a 0.9 per cent NaCl solution.

III. A determination of the increase in the electrical conductivity of a 0.9 per cent NaCl solution brought about by a 10 per cent increase in NaCl; and whether this increase would compare with the differences found between the electrical conductivity of the lymph and serum. This latter was tried as a check on the work of Carlson, Greer, and Luckhardt on "The excess of chlorides in the lymph."

#### I. THE ELECTRICAL CONDUCTIVITY OF THE LYMPHS AND SERUM OF THE SAME ANIMAL.

Eighteen dogs were put under light ether anesthesia, cannulas inserted into the cervical ducts, and 15-20 c.c. of clear cervical lymph were collected. The flow of lymph was accelerated by gently massaging the neck. The thoracic lymph was collected simultaneously in the usual manner.<sup>3</sup> Every precaution was taken to avoid concentration by evaporation. After the requisite amount of lymph had been collected a sample of blood was drawn from the femoral artery and

<sup>2</sup> In an extensive study of "the osmotic pressure and electrical conductivity of the fluids of unicellular organisms and of higher plants and animals," BORTAZZI (*Ergebnisse der Physiologie*, 1908, vii, pp. 310-315) reports several observations on the electrical conductivity of the serum and lymphs (thoracic and cervico-brachial) of the same animal with results similar to my own. The present work was completed before BORTAZZI's article came to hand, and since the present investigation is not only based on considerations of previous work of which BORTAZZI evidently had no knowledge, *i. e.*, the excess of chlorides in the lymph, but also contains other data of certain significance in a discussion on the cause of the difference in the electrical conductivity of lymphs and sera, the writer feels justified in publishing a brief report of his entire work.

<sup>3</sup> The dogs were chosen at random. Some were large with normal thyroids; others were of medium size but goutous.

immediately centrifugalized after being defibrinated. A sample of the serum was used for the conductivity determinations. The fibrin was removed from the coagulated lymph by expressing the clot with a clean glass rod. The lymph serum thus obtained was used in making the determinations. A given quantity of each of the fluids was successively placed in a small Arrhenius cell and the electrical resistance of each fluid determined by the Hartmann-Braun modification of the Wheatstone bridge at  $35.3^{\circ}$  C. Since the conductivity is the reciprocal of the resistance, the former is expressed as  $1/x$ ,  $x$  denoting the resistance. The conductivity of a  $n$  25 KCl solution being fixed at 1, the comparative conductivity of the fluids is expressed in terms of that solution.

**Results.** — Although there was considerable variation in the comparative conductivity of the sera and the cervical lymphs of different animals, in every instance the conductivity of the cervical lymph was greater than the conductivity of the corresponding serum (Table I). The electrical conductivity of a  $n$  25 KCl solution being one, the average increase of the cervical lymphs over the corresponding sera amounted to 0.572 — the greatest individual increase being 0.898, the smallest 0.389. As long as the thoracic lymph was clear and resembled the cervical lymph in appearance, its conductivity was found to be greater than the corresponding serum, but less than the corresponding neck lymph. In several instances, however, when the thoracic lymph was opalescent or distinctly chylous, the conductivity approached the conductivity of the serum, was identical with, or less than the corresponding serum (Experiments XI, XIV, XV, and XVII).

The increase in the electrical conductivity of the lymphs over the serum of the same animal found in these experiments certainly is appreciable, and in a general way confirms the results of Carlson, Greer, and Luckhardt on the excess of chlorides in the lymph. The fact that the conductivity of the thoracic lymph as a rule decreases or may become less than the serum as this lymph becomes chylous makes it seem very probable that the fat droplets in the chyle cause a depression of the conductivity by offering an increased resistance to the passage of the ions.

## II. THE EFFECT OF PROTEIN ON THE ELECTRICAL CONDUCTIVITY.

At this point we must, however, consider what effect proteins have on the electrical conductivity of a salt solution; for the unequal dis-

tribution of the proteins in the serum, thoracic, and cervical lymph may account for the differences in the electrical conductivity found between these fluids. The serum contains approximately twice as much

TABLE I.

THE COMPARATIVE ELECTRICAL CONDUCTIVITY OF DOG'S SERUM, THORACIC AND CERVICAL LYMPHS AT 35.3° C.  $1/x$  of  $n/25$  KCl = 1.000.

Exp.	Date.	$1/x$ of serum.	$1/x$ of cerv. lymph.	Increase of cerv. lymph over serum.	$1/x$ of thor. lymph.	Increase of thor. lymph over serum.
	1908					
I.	July 17	3.033	....	....	3.305 (clear)	0.272
II.	July 18	2.857	3.461	0.604	2.946 (clear)	0.089
III.	July 23	2.739	3.215	0.476	....	....
IV.	July 24	2.409	2.923	0.514	2.623 (clear)	0.214
V.	July 27	2.262	2.833	0.571	2.490 (clear)	0.228
VI.	July 28	2.857	3.444	0.587	2.921 (clear)	0.064
VII.	July 29	2.600	2.998	0.398	2.684 (chylous)	0.084
VIII.	July 30	2.898	....	....	2.985 (chylous)	0.087
IX.	Aug. 5	2.293	....	....	2.414 (opalescent)	0.121
X.	Aug. 6	3.278	3.695	0.417	3.318 (chylous)	0.040
XI.	Aug. 7	2.584	....	....	2.364 (chylous)	-0.220
XII.	Aug. 8	2.816	3.714	0.898	2.861 (opalescent)	0.045
XIII.	Aug. 14	3.042	3.723	0.681	3.063 (chylous)	0.021
XIV.	Aug. 15	3.921	4.523	0.602	3.921 (chylous)	0.000
XV.	Aug. 18	2.597	3.255	0.658	2.243 (chylous)	-0.354
XVI.	Oct. 8	3.255	3.816	0.561	3.460 (chylous)	0.205
	1909					
XVII.	Oct. 10	2.857	3.246	0.389	2.906 (chylous)	0.049
XVIII.	Oct. 14	2.855	3.486	0.631	2.937 (chylous)	0.082

protein as the lymph coming normally from the lower extremities; whereas the protein content of the thoracic lymph approximates the protein content of the serum (Starling). It was, therefore, necessary to determine what effect if any the addition of protein had on the elec-

trical conductivity of an electrolyte, 0.9 per cent NaCl solution. Preliminary experiments showed that C. P. egg-albumin and C. P. blood albumin were not sufficiently salt free to determine this point; for it was found that the conductivity of the 0.9 per cent NaCl solution increased with increase in the concentration of the protein in the solution. Crystalline egg-albumin was therefore prepared according to the method given by Hopkins.<sup>4</sup> After a single recrystallization the product was dissolved in a minimum of distilled water. To free the albumin solution from every trace of ammonium sulfate and acid used in the precipitation the solution of egg-albumin was placed in a parchment sac previously tested for any leaks and the parchment sac in turn immersed in a crock containing running water. A little thymol was added to prevent putrefaction. Dialysis was allowed to go on for one week against running tap water, and thereafter against distilled water until a small sample of the solution of albumin failed to give a precipitate of BaSO<sub>4</sub> when treated with BaCl<sub>2</sub>. The solution was filtered. To get rid of the water the slightly brownish albumin solution was spread over long glass plates, and these in turn were placed in a current of warm air, care being taken not to approach 56° C., the coagulation temperature of egg-albumin. The thymol volatilizes during the process of evaporation. The dried egg-albumin was scraped from the glass plates, and inasmuch as an incineration of a weighed quantity yielded only an almost inappreciable residue the preparation was considered fairly salt free. Conductivity determinations were then made of different per cent solutions of this albumin in 0.9 per cent NaCl solution. The results are recorded in Table II.

TABLE II.

EFFECT OF SALT-FREE EGG-ALBUMIN ON THE ELECTRICAL CONDUCTIVITY OF A 0.9 PER CENT NaCl SOLUTION AT 35.3° C.

Per cent solution.	1/x
10	3.333
5	3.571
1	3.703
0.9 NaCl alone <sup>1</sup>	3.703

<sup>1</sup> Difference between 0.9 per cent NaCl solution and a 10 per cent egg-albumin solution = 0.370 of a *n*/25 KCl solution whose conductivity (1/x) = 1.000.

<sup>4</sup> HOPKINS, F. G.: Journal of physiology, 1899-1900, xxv, p. 309.

**Results.** — It is evident from the table that the salt-free egg-albumin depresses the conductivity of a physiological saline solution. The decrease in the conductivity, considering the high per cent of protein solution, does not at all compare with the difference in the electrical conductivity found between cervical lymph and serum; for in one case we have a solution ten times richer in protein than a 0.9 per cent NaCl solution with a depression of 0.370, whereas serum is only four times as concentrated in protein as cervical lymph, and yet the increased conductivity of the lymph over the corresponding serum averages 0.572 of a *n* 25 KCl solution. From this it conclusively follows that the increased conductivity of cervical lymph over that of serum is not only due to the depression of the conductivity of the latter fluid by the greater amount of protein which it contains, but also — and for the most part — to an increased amount of electrolytes contained in the lymph.

### III. INCREASE IN ELECTRICAL CONDUCTIVITY OF 0.9 PER CENT NaCl SOLUTION BROUGHT ABOUT BY A 10 PER CENT INCREASE IN NaCl.

Lastly I determined whether an increase of 10 per cent NaCl in a given solution would cause an increase in conductivity comparable to the difference in conductivity found between lymph and serum; for a difference of 10 per cent chlorides in favor of the lymph was found by Carlson, Greer, and Luckhardt. I adopted the following procedure. To flasks containing 100 c.c. of a 0.9 per cent NaCl solution was added an additional 0.09 gm. NaCl. The conductivity of the 0.99 per cent NaCl solution was compared with an original sample of 0.9 per cent NaCl. The 0.9 per cent solution represented the serum and the 0.99 per cent NaCl solution represented the lymph. In each instance the so-called lymph had a greater conductivity than the "serum." The difference amounted to 0.378. Though the difference found is somewhat lower than the average conductivity found between the fluids themselves, the result not only confirms the previous work on the excess of chlorides in the lymph, but also indicates that there are other salts present in the lymph in greater excess than in the serum which together with the chlorides are responsible for the greater electrical conductivity of this body fluid.<sup>5</sup>

<sup>5</sup> Dr. A. WOELFEL of this laboratory is at present engaged in a quantitative study of the inorganic bases of both fluids.

## DISCUSSION.

To those interested in the much discussed problem of the mechanism of lymph formation the facts reported in this paper are of some interest and significance. The increased electrical conductivity of the lymphs over the sera, together with the previously reported finding of an excess of chlorides in the lymph are facts which appear incompatible with any purely mechanical theory of lymph formation; for on the grounds of filtration the quantitative salt content and electrical conductivity of both lymph and serum ought to be the same; according to the theory of osmosis the quantitative relationship of these electrolytes ought to be *maintained* the same.

It is true that the serum contains a greater amount of protein than does the lymph. But the results of this investigation show that salt-free coagulable egg-albumin which resembles the serum proteins does not depress the conductivity of an electrolyte (0.9 per cent NaCl solution) greatly even when in concentrated solution or to any extent sufficient to warrant the conclusion that the difference in electrical conductivity between the two body fluids is the result of their difference in protein content. The manner in which salt-free egg-albumin depresses the conductivity of a 0.9 per cent NaCl solution remains problematical. Whether the depression is due to the great size of the inert protein molecule and its resistance to the passage of the ions or whether the addition of proteins to a physiological saline solution as in these experiments leads to adsorption of a certain amount of the salt (electrolyte) are offered as conjectures.

At the time that the investigations on the Cl content of the lymph and serum of seventeen horses and five dogs was completed at this laboratory we came upon certain statements in Hamburger's "Osmotischer Druck und Ionen Lehre" which strongly suggested that Hamburger had made similar Cl determinations and had as a result found that the lymph possessed more Cl than the corresponding serum. Hamburger writes: <sup>6</sup> "Aus den vergleichenden Analysen von Blutserum und Lymphe hat sich hingegen herausgestellt, dass der oft viel höhere osmotische Druck der letztgenannten Flüssigkeit nahezu vollständig einem höherem Gehalt an Chloriden und Alkali entspricht." No direct reference was given by Hamburger to any comparative Cl determinations of these

<sup>6</sup> HAMBURGER, H. J.: Osmotischer Druck und Ionenlehre, 1904, ii, p. 53.

fluids. Lately in reviewing the literature on lymph formation I find that the statement of Hamburger quoted above is based on the results of a single experiment published in 1893.<sup>7</sup> Hamburger then must be credited with priority in the discovery of the excess of chlorides in the lymph in spite of the fact that his general statement on the excess of chlorides in the lymph is based on a single experiment. The increase in electrical conductivity of the lymph over the serum found by Bottazzi and myself confirms the results of Hamburger and Carlson, Greer, and Luckhardt on the excess of Cl in the lymph.

What, then, is the explanation of the excess of salts (chlorides) in the lymph? Starling writes:<sup>8</sup> "It is quite possible that the lymph may have taken up its excess of salts from the tissue cells, and that the fluid as it left the blood vessels had the same or a lower osmotic pressure than the blood plasma . . ." and "that we are perfectly ignorant what changes it [the lymph] has undergone on its way through the tissues from the blood vessels to the cannula in the lymphatic duct." This is undoubtedly a possibility. At the same time it is evident that if seriously considered it would remove the problem of lymph formation beyond experimentation and place it into the field of pure speculation.

Since the per cent and tension of CO<sub>2</sub> are less in the lymph than in venous blood, the explanation of Hamburger<sup>9</sup> is worthy of consideration. Hamburger writes: "Bei näherer Betrachtung erscheint es mir als nicht unmöglich, dass der hohe osmotische Druck der Lymphe u. a. darauf zurückzuführen ist dass die Lymphe CO<sub>2</sub>-Ionen aus den Geweben an das Blutserum abgibt und die doppelte Menge Chlor-Ionen dagegen eintauscht: In Folge dessen steigt der osmotischer-Druck der Lymphe. Der erhöhte Gehalt der Lymphe an Cl wurde mit dieser Erklärung übereinstimmen."

It appears to me that Hamburger did not sufficiently emphasize the importance of his discovery of the excess of Cl in the lymph over the serum, owing to the fact perhaps that he had but one experiment to support him. Now that the work has been repeated and confirmed by

<sup>7</sup> HAMBURGER, H. J.: *Zeitschrift für Biologie*, 1893, xxx, p. 143. A record of the same experiment was published in an article: "Hydrops von mikrobiellen Ursprung," HAMBURGER, H. J., *Beiträge zur pathologischen Anatomie und zur allgemeinen Pathologie*, 1893, xiv, p. 448.

<sup>8</sup> STARLING, E. H.: *Journal of physiology*, 1894, xvi, p. 224.

<sup>9</sup> HAMBURGER, H. J.: *Osmotischer Druck und Ionenlehre*, 1904, ii, p. 54.



twenty-two experiments on horses and dogs and it has likewise been shown that the electrical conductivity of the lymph is greater than the serum, we have facts which appear incompatible with any purely mechanical theory of lymph formation.

#### CONCLUSIONS.

1. The work of Bottazzi and that of the present paper confirm the work of Hamburger, Carlson, Greer, and Luckhardt on the excess of chlorides in the lymph by showing that lymph is a better electrical conductor than the serum.

2. The protein, egg-albumin, depresses the conductivity of an electrolyte. Since the blood serum is more concentrated in proteins than the lymph, the greater conductivity of the latter might possibly be explained on the basis of its smaller protein content. It was, however, shown that the depression of 0.9 per cent NaCl solution by egg-albumin even when in high concentration is slight and inadequate to explain the great difference in conductivity found between lymph and serum.

3. The fat droplets contained in chylous thoracic lymph depress the conductivity of this lymph by physically offering a resistance to the passage of the ions.

4. A 10 per cent increase in the NaCl content of a physiological saline solution causes an increase in the electrical conductivity of the solution which is comparable to the increased conductivity of the lymph over the serum.

5. Why there is an excess of chlorides in the lymph and how this condition is brought about awaits an explanation. Hamburger's suggestion that the lymph gives up its  $\text{CO}_2$ -ions which it has received from the tissue cells to the blood in exchange for twice the amount of Cl-ions is in harmony with the facts that the lymph contains more salts and is a better electrical conductor than the serum, and that the per cent and tension of  $\text{CO}_2$  are less in the lymph than in the venous blood.

6. The excess of chlorides in the lymph, together with the greater conductivity of the latter, appears to be incompatible with a purely mechanical theory of lymph formation.

I wish to thank Dr. Anton J. Carlson for suggestions and encouragement during the progress of the work.

CONTRIBUTIONS TO THE PHYSIOLOGY OF LYMPH.—  
XI. THE FRACTIONAL COAGULATION OF LYMPH.

By HERBERT O. LUSSKY.

[From the Hull Physiological Laboratory, The University of Chicago.]

I.

AS the knowledge of the mechanism of the coagulation of blood and lymph has developed, it has from time to time become necessary to revise the theory of the mechanism of this phenomenon in order to make it harmonize with the new facts disclosed. The main tendency has been towards a more complex explanation. From Schmidt's first relatively simple theory, in which he assumes coagulation to be the result of the combination of two soluble albumins under the influence of a specific ferment in the presence of neutral salts, up to the present time, more and more factors have been found to be involved in the process. The specific rôle of fibrinogen, thrombin, thrombokinase, tissue coagulins, various salts, the formed elements of the blood, the effect of temperature, pressure, contact with foreign elements, the gaseous conditions, and many other influences have been extensively investigated both *in vitro* and *in vivo*.

But, in spite of the many facts known, different workers have come to widely diverging conclusions regarding the exact mechanism of coagulation. Indeed, at the present time, even the question as to whether the process of coagulation is in reality a ferment action is disputed. Morawitz<sup>1</sup> assumes a ferment action, Leo Loeb<sup>2</sup> leaves it an open question, while Rettger<sup>3</sup> denies it. It would not be surprising, therefore, if the opinions on the mechanism of the second coagulation should be even more diverging than those on the first.

Fractional coagulation of mammalian blood, though a rare occurrence, has been observed in this laboratory on five different occasions. The

<sup>1</sup> MORAWITZ: Beiträge zur chemischen Physiologie, 1903, iv, p. 381.

<sup>2</sup> LOEB: Biochemisches Centralblatt, 1907, vi, pp. 829, 889.

<sup>3</sup> RETTGER: This journal, 1909, xxiv, p. 406.

first of these <sup>4</sup> was in a case of a woman suffering from lobar pneumonia. The blood was drawn in the ordinary way from one of the veins of the fore arm. Contrary to the usual behavior, the blood coagulated very slowly, and after defibrination a second coagulum formed. The other four cases <sup>5</sup> were observed on dog's blood. In these cases the blood was drawn from the carotid artery by means of a cannula, defibrinated by stirring with a rod for from ten to twelve minutes, and the corpuscles removed by centrifugalization. In three of these cases a coagulum was observed in the serum after about one half hour. In the fourth one coagulation took place before all of the corpuscles had settled to the bottom of the tube. After this blood was again defibrinated and replaced in the centrifuge a third clot formed.

While this phenomenon is rare in mammalian blood, it occurs not infrequently in reptilian blood. Turtle's blood was obtained under aseptic conditions by C. Brooks by sterilizing the necks of large snapping turtles, decapitating with a sterile knife, and catching the blood in sterile vessels. The blood was set aside for from twelve to eighteen hours. The serum was then poured off into other sterile vessels. After twelve to thirty-six hours a clot was observed in a large percentage of the cases.<sup>6</sup>

In mammalian lymph, however, fractional coagulation occurs almost invariably. It has frequently been observed in this laboratory by Carlson, Becht and Greer, and by Carlson and Woelfel,<sup>7</sup> that lymph, on being defibrinated two and three hours after the first coagulation, formed a second clot. Even after remaining at 0° C. for from twenty-four to thirty-six hours after the formation of the first clot, lymph coagulated spontaneously a few minutes after defibrination. Great differences in the tendency to form this second coagulation were observed in different samples. Sometimes, as stated above, a second clot would form after thirty-six hours, whereas at other times no second clot would appear, even when defibrination occurred five minutes after the first coagulation.

Various working hypotheses may be offered to account for this process. Lymph differs from blood quantitatively as well as qualitatively. There is less fibrinogen in the lymph; there are no erythrocytes or polymorph-nuclear leucocytes;<sup>8</sup> there is also a lower concentration of immune

<sup>4</sup> S. A. MATTHEWS: Personal communication.

<sup>5</sup> BECHT and GREER: Personal demonstration.

<sup>6</sup> C. BROOKS: Personal communication.

<sup>7</sup> CARLSON: Personal communication.

<sup>8</sup> DAVIS and CARLSON: This journal, 1909, xxv, p. 173.

bodies, ferments, and related elements in the lymph. Both blood plates and leucocytes are assumed to yield kinase and prothrombin. Since there is little thrombin and related bodies present, it is highly probable that there is also little thrombogen present in the lymph. Therefore it may well be that successive coagulation in the lymph is due to the relatively greater dilution of these two essential elements, fibrinogen and prothrombin.

It may be that the whole matter depends upon the amount of fibrinogen present. In this case it might be assumed that there is an abundance of fibrin ferment present, but a small amount of fibrinogen in the lymph freshly drawn. The first coagulation would use up all of the fibrinogen present at that time. The lymphocytes present in the lymph might by breaking down form additional fibrinogen which would be used in the second coagulation. This process might be repeated until all the leucocytes were used up. The difference in the tendency in the blood and the lymph to form a second coagulation would therefore depend upon the number of lymphocytes broken down before drawing and the rapidity of the breaking down after drawing these fluids. As has been shown by Davis and Carlson,<sup>8</sup> the thoracic lymph pours into the blood in the course of a day over three times as many lymphocytes as are found in the blood at any one time. Thus in the lymph would be found many newly formed, possibly stable lymphocytes, which break down very gradually after drawing the lymph, and very little fibrinogen; while in the blood would be found fewer and older lymphocytes, which break down rapidly after drawing the blood, and very much fibrinogen. Thus in blood all the available fibrinogen is present at the time of drawing, while in lymph the fibrinogen is but slowly released.

On the other hand, it is conceivable that the amount of fibrin ferment present is the determining factor. On this assumption there would be sufficient fibrinogen present but an insufficiency of fibrin ferment for rapid coagulation. This lack of ferment so delays the process of complete coagulation that it continues slowly for hours or even days before all of the fibrinogen is converted into fibrin. Defibrination done during the continuance of this coagulation only removes all of that fraction of fibrinogen which is coagulated at that time, leaving the process of slow coagulation still going on. Other defibrinations may be made from time to time until finally all of the fibrinogen is converted into fibrin. Thus the difference in the tendency in blood and in lymph to form a second

coagulation would be due to the difference in the amount of ferment which they contain. Since the lymph contains less organic solids and anti-bodies, so also it would be expected to contain less fibrin ferment than the blood.

II. LITERATURE.

As regards the rate of the first coagulation in blood and in fibrinogen solutions, the general opinion of the investigators seems to be that it is, within certain limits, proportional to the amount of ferment present. Leo Loeb,<sup>9</sup> working on the plasma of lobsters, shows that within the bounds of experimental error there is a direct proportionality between the rate of coagulation and the amount of thrombin present. The slight deviations in his results he attributes to the inability to obtain an indifferent solution for dilution. The following figures are quoted from his tables:

2 c.c. lobster plasma + 2 c.c. serum . . . . .	Coag. 5 min. 45 sec.
2 c.c. lobster plasma + 1 c.c. serum + 1 c.c. inactive serum . . . . .	“ 10 “ 9 “
2 c.c. lobster plasma + .25 c.c. serum + 1.75 c.c. inactive serum . . . . .	“ 49 “ 20 “

Mellanby,<sup>10</sup> working on fibrinogen solution, finds that the coagulation time is “approximately inversely to the amount of ferment added.” The following figures are quoted:

Fibrinogen suspension.	NaCl (15%).	H <sub>2</sub> O	Fibrin ferment. c.c.	Coag. time in seconds.
.5 c.c.	.1 c.c.	.4	1	7
		.5	.9	10
		.6	.8	15
		.7	.7	17
		.8	.6	20
		.9	.5	25
		1.0	.4	30
		1.1	.3	40
		1.2	.2	50
		1.3	.1	120

<sup>9</sup> LOEB: Beiträge zur chemischen Physiologie, 1907, ix, p. 185.

<sup>10</sup> MELLANBY: The journal of physiology, 1908, xxxviii, p. 28.

Mellanby shows that fibrin ferment is removed with the fibrin in the process of coagulation, and points out the "two main possibilities (a) that the ferment combines with the fibrinogen to form fibrin, (b) that the ferment adheres to the fibrin in a way which may be described by the term adsorbed." The first possibility he shows cannot be correct, since a very small amount of ferment will finally coagulate a large amount of the fibrinogen solution provided the coagulum is not removed. But if the first coagulum be removed the process goes on much slower, thus indicating that some of the ferment had been removed with the fibrin. He further shows, by means of washing and extracting the fibrin formed, that a ferment rich solution can be obtained. He therefore concludes that "when a fibrinogen solution is coagulated by ferment, a portion of the ferment is adsorbed by the formed fibrin. This adsorbed ferment can still coagulate other fibrinogen, as is shown by the slow but complete coagulation of fibrinogen solutions to which small quantities of ferment have been added (coagulation in some cases may take days to complete itself)."

On varying the concentration of the fibrinogen and leaving all other factors constant he finds the rate of coagulation to be inversely to the concentration of the fibrinogen.

Fibrinogen in .75% NaCl.	.75% NaCl.	Ferment solution.	Coag. time in minutes.
1.0	1.8	2	1
1.5	1.3	2	1½
2.0	.8	2	13
2.5	.3	2	10

Rettger,<sup>3</sup> also working on fibrinogen solutions, obtains similar results on varying the concentration of the ferment. The following table is quoted:

- 20 c.c. fibrinogen + 40 drops thrombin extract, 14 minutes.
- 20 c.c. fibrinogen + 20 drops thrombin extract, 26 minutes.
- 20 c.c. fibrinogen + 10 drops thrombin extract, 30 minutes.
- 20 c.c. fibrinogen + 5 drops thrombin extract, 90 minutes.

Bayliss<sup>11</sup> has shown that under certain conditions the same thing is true for the digestive ferments. He finds that when a small amount of trypsin acts upon a large amount of casinogen, the velocity of the reaction

<sup>11</sup> BAYLISS: The nature of enzyme action, 1908, p. 55.

is a direct linear function of the amount of ferment present. The time taken for a certain definite change to take place is inversely proportional to the concentration of the ferment.

### III. METHODS.

The work was divided into two sets of experiments: the one carried out on thoracic lymph of dogs; the other on fibrinogen solutions made from dog's blood. In order to obtain the lymph with as little injury to the formed elements as possible and without any possible contamination with substances from the surrounding tissues, the thoracic duct was exposed with as bloodless an operation as possible, doubly ligated and cut. If there happened to be the slightest trace of blood on the duct, warm 0.9 per cent sodium chloride solution was used to remove it. A specially prepared paraffined pipette was then inserted and held in place by means of a serrasfin. After four or five minutes, when the bulb of the pipette, which usually held about 30 c.c. was full, the lymph was removed to the tubes in which it was wanted. Lymph drawn in this way, unless it was bloody due to the struggling of the animal while being anæsthetized, always coagulated slower than the blood (from ten to forty minutes). If the lymph was kept in the pipette or transferred to a paraffined tube, the coagulation time was greatly lengthened, in one case as much as three hours. The pipette could not be used a second time, since the lymph obtained by the second drawing coagulated about twice as fast as the lymph which was obtained by the first drawing.

Lymph from the first drawing coagulated in nineteen minutes.

Lymph from the second drawing coagulated in ten minutes.

Fibrinogen solutions were prepared from dog's blood drawn from the carotid artery into a 1 per cent solution of sodium oxalate in 0.9 per cent sodium chloride, through a cannula washed in sodium oxalate solution. One volume of oxalate solution was used to every four of blood. The corpuscles were centrifuged out and the plasma added to an equal volume of saturated solution of sodium chloride. The precipitated fibrinogen was centrifuged out and dissolved in a 4 per cent solution of sodium chloride. It was again precipitated by adding an equal volume of a saturated sodium chloride solution, centrifuged out and dissolved in a 0.9 per cent solution of sodium chloride in volume equal to one half of that of the plasma originally obtained. This solution

was dialyzed against a large amount of a 0.9 per cent solution of sodium chloride for twenty-four hours, in order to remove the remaining oxalate and to secure for the solution a known percentage of sodium chloride.

For the purpose of investigating the effect of salts on the successive coagulations of lymph there was prepared a saturated solution of magnesium sulphate, a 1 per cent solution of potassium oxalate in 0.9 per cent of sodium chloride and a 1.2 per cent solution of sodium fluoride in 0.9 per cent sodium chloride. The solutions were all sterilized.

The serum was obtained by defibrinating dog's blood and centrifugalizing out the corpuscles.

The coagulation time was taken when the tube could be inverted without spilling any of the contents.

#### IV. RESULTS.

The first point investigated was the effect of salt on the successive coagulations of lymph. One cubic centimetre from each of the solutions (magnesium sulphate, potassium oxalate, and sodium fluoride) were placed in three separate test-tubes, each containing 3 c.c. of lymph. In no case did coagulation take place, although the addition of 1 c.c. of water caused coagulation. On the addition of 1 c.c. of serum to 1 c.c. of each of these mixtures coagulation resulted every time. But on the addition of 1 c.c. of 0.2 per cent calcium chloride solution coagulation took place only in the solution containing oxalate.

*Potassium oxalate also retards and hinders the second coagulation of lymph (Table I).* — The lymph was drawn into an ordinary non-paraffined pipette (coagulated in seven minutes). It was immediately defibrinated. Two cubic centimetres of the defibrinated lymph were added to varying amounts of potassium oxalate. The time of coagulation was lengthened with increased amounts of oxalate. Two more samples of lymph were drawn. One was added to one fourth of its volume of potassium oxalate solution. The other was allowed to coagulate spontaneously. The former showed no sign of coagulation even after twenty-four hours, while the latter coagulated in twelve minutes. One half of the latter, after defibrination, was added to one fourth of its volume of potassium oxalate solution. The other half remained undisturbed. It



coagulated in one and one-half minutes. In the first half there developed a very slight flocculent coagulum. It was divided into two portions. To one was added calcium chloride, which caused it to coagulate solid. The other portion did not develop any further clot.

TABLE I.

THE EFFECT OF ADDITION OF VARYING AMOUNTS OF POTASSIUM OXALATE ON THE SECOND COAGULATION OF LYMPH.

C.c. of $KC_2H_3O_2$ added to 2 c.c. of def. lymph.	0	.01	.02	.03	.04	.05	.06	.07	.08	.09	.10	.20
Coagulation time in minutes.	6	6	6	6	10	11	11	11	14	18	18	0 <sup>1</sup>
<sup>1</sup> No coagulation even after twenty-four hours.												

Varying amounts of serum were added to different samples of lymph (Table III). Five minutes after the first coagulation the different samples were defibrinated. It invariably happened that *those samples which contained the most ferment during the process of the first coagulation gave the least second coagulation, and those samples which contained the least*

TABLE II.

THE EFFECT OF BLOOD ON THE SUCCESSIVE COAGULATIONS OF LYMPH.

Lymph.	Coagulation time in minutes.			
	First.	Second.	Third.	Fourth.
Blood-free lymph . . .	37	11	210	None
Bloody lymph . . . .	3	None	None	None

*ferment in the beginning gave the greatest second coagulation.* Every time that the lymph was markedly bloody the first coagulation was rapid and no second coagulation was obtained, whereas when the lymph was absolutely bloodless the first coagulation was long in forming and two and three successive coagulations could be obtained (Table II).

When varying amounts of serum were added to 2 c.c. of lymph and the interval between coagulation and defibrination was one hour, coagulation resulted only in those samples which contained a small amount of ferment.

When blood-free lymph was placed in the ice chest immediately upon being drawn, a second coagulum formed after twenty-four hours. But

TABLE III.

THE EFFECT OF VARYING THE AMOUNT OF FERMENT IN THE LYMPH. EACH SAMPLE WAS DEFIBRINATED FIVE MINUTES AFTER THE FIRST COAGULATION.

Lymph.	Serum.	Coagulation time in minutes.	
		First.	Second.
c.c. 2	c.c. 0.00	10	2
2	0.04	2	2
2	0.08	2	2
2	0.10	2	2 (not solid)
2	0.20	2	Slight flocculent
2	0.30	2	Very slight flocculent

TABLE IV

THE EFFECT OF VARYING THE AMOUNT OF FERMENT IN THE LYMPH. EACH SAMPLE WAS DEFIBRINATED ONE HOUR AFTER THE FIRST COAGULATION.

Lymph.	Serum.	Coagulation time in minutes.	
		First.	Second.
c.c. 2	c.c. 0.00	15	3
2	0.04	4	4
2	0.10	3	None
2	0.20	3	None
2	0.30	3	None

when blood-free lymph was kept at room temperature or when lymph to which 0.05 c.c. of blood had been added was placed in the ice chest, no second coagulum could be obtained after twenty-four hours

(Table V). To equal volumes of fibrinogen solutions were added varying amounts of serum and sufficient sodium chloride solution (0.9 per cent) to keep the concentration of the fibrinogen constant. The speed of coagulation varied with the amount of serum added. Five

TABLE V.

THE EFFECT OF VARYING THE TEMPERATURE AND THE AMOUNT OF FERMENT IN THE LYMPH. EACH SAMPLE WAS DEFIBRINATED TWENTY-FOUR HOURS AFTER THE FIRST COAGULATION.

Lymph.	Serum.	Temperature.	Coagulation time in minutes.	
			First.	Second.
c.c. 2	c.c. 0	Room	19	None
2	0	Ice chest	Within 30	5
2	0.05	Ice chest	Within 30	None

TABLE VI.

THE EFFECT OF VARYING THE AMOUNT OF FERMENT IN FIBRINOGEN SOLUTIONS.

Sample.	Fibrinogen.	Serum.	0.9 per cent NaCl.	Coagulation time in minutes.		
				First.	Second.	Third.
1	c.c. 2	c.c. 0.05	0.95	45	None	None
2	2	0.01	0.90	45	3	Slight
3	2	0.15	0.85	40	3	Slight
4	2	0.20	0.80	35	4	....
5	2	0.40	0.60	11	Slight	....
6	2	0.60	0.40	6	Very slight	....
7	2	0.80	0.20	4	None	....
8	2	1.00	0.00	4	None	....
9	2	2.00	0.00	3	None	....

minutes after coagulation the samples were defibrinated. No second coagulation formed in those samples containing a large amount of serum nor in the sample containing the smallest amount of serum. A slight third coagulation was obtained in those samples, with the exception of sample 1, which contained the least ferment.

Two tenths of a cubic centimetre of serum was added to 5 c.c. of fibrinogen solution. After twenty-four hours it was defibrinated, but no second clot formed. To another sample of 5 c.c. of fibrinogen solution was added 0.2 c.c. of serum which had been diluted with nine volumes of sodium chloride solution (0.9 per cent). After twenty-four hours a second coagulation was obtained upon defibrination. To the third sample of 5 c.c. of fibrinogen solution was added 0.2 c.c. of serum which had been diluted with ninety-nine volumes of sodium chloride solution (0.9 per cent). During the course of the first twenty-four hours a slight flocculent precipitate was formed, which increased during the second twenty-four hours. During the third and fourth twenty-four hours there was no perceptible increase in the precipitate. This was most probably due to the ferment becoming inactive by long standing.

## V. CONCLUSIONS.

All of these results show that the greater the amount of ferment present and the longer the interval between the first coagulation and defibrination the less is the tendency to form successive clots, and, *vice versa*, the less the amount of ferment present and the shorter the interval between the first coagulation and defibrination the greater is the tendency to form successive clots. The smaller the amounts of ferment added to the same amounts of fibrinogen the longer may be the interval after which a second coagulation can be obtained. Successive coagulations, therefore, depend upon the amounts of ferment present in the coagulating fluid. If very small amounts of ferment are present, the coagulation process goes on so slowly that during its progress the formed fibrin can from time to time be removed, whereas, when large amounts of ferments are present, the coagulation process proceeds so rapidly that all of the fibrinogen is converted into fibrin and removed by the first defibrination.

These results would then be in agreement with those of Bayliss on the digestive ferments in showing that in great dilutions of the ferment the

time required for effecting a certain amount of change in the substrate is proportional to the amount of ferment present.

One cannot prove that the process of coagulation is a quantitative reaction and not due to a ferment action by adding varying amounts of ferment to different samples of fibrinogen solutions and after a definite time making a quantitative estimation of the amount of fibrin formed, as is assumed by Rettger. In the first place, the smaller the amount of ferment present the slower will the processes of coagulation proceed. Thus after an interval the most fibrin will be found in the sample containing the most ferment, and the least fibrin in the sample containing the least ferment.

In the second place, if no second coagulation results after defibrinating (when small amounts of ferment are added to a fibrinogen solution), the conclusion that the ferment combined chemically with some of the fibrinogen is not justifiable, for, as Mellanby has pointed out, the ferment can be removed from the solution by means of adsorption. There is also, in all probability, a gradual destruction of the ferment, possibly by oxidation.

The most simple way in which the nature of this reaction can be tested is by arranging several sets of equal samples of fibrinogen solutions to which varying amounts of ferment have been added. After twelve hours a quantitative estimation of the fibrin formed in the different samples of the first set would be made; after twenty-four hours in those of the second set, etc. If after twelve, twenty-four, or thirty-six hours the amounts of fibrin in the different samples vary from each other and are equal in amount to the corresponding samples in the sets which were left to coagulate a longer time, then the quantitative nature of the thrombin would be established. But if the amounts of fibrin in the samples tend to become equal in the different sets on continued standing, then the ferment nature of the thrombin would seem the more probable.

The results of the present work indicate that the successive coagulations in the lymph are due to the small amount of fibrin ferment present and the consequent slow rate of coagulation. This inhibition of the second and third coagulations by the lack of calcium seems to show that the conversion of prothrombin to thrombin in the lymph is also a very slow and gradual process, assuming with Morawitz and others that the

calcium is not necessary for the precipitation of the fibrinogen by the thrombin. This point is now under investigation.

This work has been done under the direction of Dr. A. J. Carlson, for whose constant interest and valuable suggestions the author is very grateful.

# THE REGENERATION OF NERVE AND MUSCLE IN THE SMALL INTESTINE

BY WALTER J. MEEK.

[*From the Hull Physiological Laboratory of the University of Chicago, and the  
Physiological Laboratory of the University of Wisconsin.*]

THE solution of more than one problem in physiology awaits a wider understanding of the nerve plexuses in the intestine. This knowledge would be particularly valuable in interpreting certain observations on the heart. The zig-zag experiments of Engelmann, the bridge experiments of Porter and Fredericq, and the observation that contraction spreads in all directions from the point of stimulation have forced those holding the neurogenic conception of the heart beat to assume that automaticity and conduction depend upon nerve plexuses in the heart muscle. Whether this assumption is correct can be told only after the physiology of these tissues is better known.

The present investigation began in an attempt to determine whether Auerbach's plexus would regenerate. It seemed desirable to know if in this particular the plexus differed from the central nervous system. From this prime object the work was necessarily extended to the regeneration of muscle.

## METHODS.

Cats and dogs were used in these experiments. The general plan was to make transections of the intestine, allow time for regeneration, and then test for the passage of peristalsis across the line of section. That the passage of peristalsis would be sufficient evidence of regeneration was assumed from the work of Bayliss and Starling and of Magnus, who have shown that intestinal movements depend for their conduction on the plexus of Auerbach. It is well known that after recovery

<sup>1</sup> I wish to express my indebtedness especially to Dr. Carlson of the University of Chicago as well as Dr. Erlanger of the University of Wisconsin, who have given advice and help in the work.

from transection food passes along the intestine in an apparently normal fashion, but whether peristaltic waves pass the line of suture or whether the food is ever after simply crowded through this region, has never been reported. To eliminate as far as possible any experimental errors cats were also studied under the X-ray. Histological examinations were made in all cases.

Under ether anaesthesia the abdomen was opened and a loop of the small intestine raised to view. Stitches were laid at once and the intestine then cut across between and beneath the stitches. The intestine was completely transected, and to make sure, the cut was carried a short distance into the mesentery. An end to end anastomosis was then quickly made by drawing the stitches tight. Black silk thread was used. Recognition stitches were placed on each side of the suture, and in these a loop of silver wire was tied in those cases intended for X-ray examination. The work was done aseptically, and in every case reported the recovery was rapid and without any particular incident. The animals were tested for peristalsis in from two to two hundred and forty days.

In testing for peristalsis a tracheotomy was made and the animal kept under light ether anaesthesia. The skin over the abdomen was opened along the middle line and the cut edges tied to an iron ring, thus forming a cavity in which the intestines could be kept under warm saline. This is the excellent technique for studying intestinal movements suggested by Meltzer and Auer.<sup>2</sup> When this cavity had been filled with normal salt solution at body temperature, the abdomen was opened and the transected loop was raised. The loop was laid over a small platform of cork which had been placed deep in the abdomen by means of a steel rod serving as a support. Graphic records were made by attaching one light lever to a point 1 cm. above the line of section and another an equal distance below, in such a way that the writing point of the lever rose when the circular coat of the intestine contracted.

All physiological workers know the difficulty of producing regular peristalsis in the intestines of an animal with the abdomen opened. A state of inhibition at once ensues accompanied usually by a great loss of tone. This is due to a reflex from the injured and exposed portions, the inhibition of some peripheral mechanism, or possibly to a state of

<sup>2</sup> MELTZER and AUER: *This journal*, 1907, xx, p. 259.



acapnia as recently suggested by Henderson.<sup>3</sup> This pronounced inhibition when the intestine is exposed to air is only slightly lessened by opening under normal salt solution. In our problem we were under the further necessity of having the peristalsis appear in a given loop of the intestine. Occasionally peristaltic waves are seen in animals under our experimental conditions, but rarely in our experience did the waves appear at the point desired. Stimulation by sodium chloride according to the Nothnagel method, by pinching with forceps, or by induced electrical currents all produced local contractions which seldom if ever resulted in travelling waves.

The first experiments were made on cats, and these animals proved particularly refractory in regard to intestinal movements. This finding parallels that of Bayliss and Starling,<sup>4</sup> who report in the majority of experiments in cats an almost complete absence of local reflexes. A number of methods were tried to obviate this difficulty. Henderson's<sup>5</sup> method of opening the abdomen in an atmosphere of carbon dioxide did not prove very satisfactory in our hands, although it was evident that it prevented the usual excessive loss of tone. The use of barium chloride as recommended by MacCallum<sup>6</sup> also gave negative results. Finally the injection of eserine salicylate was resorted to. This drug was used in preference to pilocarpine, since the latter seemed to produce mainly pendular movements and very seldom peristalses that travelled any distance. A one quarter grain tablet of eserine was dissolved in 20 c.c. of normal salt solution and injected in the external jugular vein in doses of 1-2 c.c. as needed.

It is assumed that under the influence of eserine conduction takes place by the same mechanism as in normal movements. This assumption seems justified, since the waves produced by eserine resemble normal waves in all important particulars. An increased rate of conduction is the chief difference. To be quite sure, however, the results were controlled by X-ray examinations.

Details in regard to the X-ray observations and the histological technique will be given later in the paper.

<sup>3</sup> HENDERSON: This journal, 1909, xxiv, p. 66.

<sup>4</sup> BAYLISS and STARLING: Journal of physiology, 1901, xxvi, p. 125.

<sup>5</sup> HENDERSON: *Loc. cit.*

<sup>6</sup> MACCALLUM: This journal, 1904, x, p. 259.

## PERISTALTIC WAVES PASS THE TRANSECTION.

The first experiments were made on eight cats. In all these the small intestine was transected and an end to end anastomosis made in the way described above. The preliminary operations were done in November and December, 1908, and the observations on peristalsis were made in May and June.

The first two cats studied may be passed briefly. Cat No. 1 was tested for the passage of peristalsis fifty-three days after transection. The animal had been suffering with some pneumonic complaint and was in such poor condition that it died while being placed in a bath of normal saline. The basin made by sewing the skin to an iron ring was not used in these first two experiments. An attempt was made to stimulate peristalsis by pinching and by applying salt crystals. Contractions were produced, but they remained local. Cat No. 2 was examined one hundred and nine days after the preliminary operation. The animal was mangy, poor, and in bad condition generally. The abdomen was opened under normal saline, and typical responses were secured by mechanical stimulation and with sodium chloride. Inhibition below and contraction above the point of stimulation were evident.

The remaining six cats of this first series were in perfect condition when tested for peristalsis. So uniform were the results and the technique that only two protocols will be given.

**Cat No. 6.** — December 26. Intestine transected. Recovery rapid and uneventful.

May 12. One hundred and thirty-seven days later tested for peristalsis.

2.30 P. M. Ether anæsthesia. Tracheotomy. Skin of abdomen opened along median line, reflected and sewed to iron ring. Cavity thus made filled with warm saline.

2.50 P. M. Abdomen opened under salt solution and transected loop drawn out. Slight adhesions of omentum along line of suture cleaned away. Intestine is enlarged above line of section, but only slightly so below.

3.10 P. M. 1 c.c. of eserine injected in external jugular.

3.13 P. M. Strong pendular movements.

3.20 P. M. 1½ c.c. eserine injected.

3.21 P. M. Peristaltic waves in various loops.

3.22 P. M. Peristalsis started just below suture line.

- 3.25 P. M. Peristalsis appeared above, but died away.
- 3.41 P. M. Antiperistalsis passes up intestine crossing line of section.
- 3.45 P. M. 1 c.c. eserine, followed by tonic spasm of whole intestine.
- 4.04 P. M. Peristalsis passed line of section. No delay.
- 4.05 P. M. Peristaltic rush swept down intestine passing through transected loop.
- 4.15 P. M. Cat pithed. Canal opened in lower cervical region.
- 4.20 P. M. Peristalsis passed. No delay. (Tracing shown in Fig. 1.)
- 4.21 P. M. Peristalsis passed. Short delay.
- 4.23 P. M. Antiperistalsis passed through loop.
- 4.50 P. M. Wave reached line of section: short delay, then passed through.
- 5.20 P. M. Cat killed. Loop with line of section removed and placed in normal salt solution. One peristaltic wave passed through loop after being placed in saline.
- Cat No. 2.** — Black female. — December 2. Intestine transected 40 cm. below duodenum. Recovery uneventful.
- May 13. Abdomen opened aseptically and two silver wires sewed on the line of section a short distance apart. No adhesions. Intestine slightly enlarged at either side of suture line.
- May 25. X-ray examination after feeding salmon mixed with bismuth subnitrate. Cat had previously been taught to lie on frame over X-ray machine. Waves were passing over stomach. Duodenum opened after every third or fourth wave. Loop of intestine with wire rings located and separated from the other loops by kneading with the fingers. Wire rings showed as circles with clear centres, and thus marked line of section. Dark mass of food to left of transected area. Latter clear. Mass of food passed to right under wire rings and then on down the intestine for some distance. The transected line was first light, then dark, then light again. That is, peristalsis carried food across the line of section. Rhythmical segmentation was not observed in region of the rings.
- June 4. X-ray examination. Stomach and intestines well filled. Emptying movements of stomach clearly seen. Rhythmical segmentation at first in upper part of intestine. Later segmentation observed in transected loop. Movements lasted a minute or more.
- June 15. One hundred and ninety-five days after transection, test made for peristalsis.
- 3.20 P. M. Ether anaesthesia. Tracheotomy. Abdomen opened under saline in usual way. Wire rings found to be in place. Wires with slight adhesions removed.

- 3.47 P. M. 1 c.c. eserine injected into external jugular.  
 3.48 P. M. Irregular contractions, lasting several minutes, but followed by orderly peristalses.  
 4.02 P. M. Wave blocked at line of section.  
 4.25 P. M. Series of waves, one about every minute. Two blocked. Third passes.  
 4.32 P. M. Wave blocked.  
 4.38 P. M. 1 c.c. eserine. Followed by irregular movements.  
 4.40 P. M. Strong peristalsis passed line of transection.  
 4.50 P. M. Cat killed.

X-ray examinations were made in only one animal of this series, the one described above. The other experiments gave precisely identical results in each of the six cats. In every case under the influence of eserine, peristaltic waves passed the line of previous section. The intestine in each experiment gave all well-known movements seen after the administration of this drug; that is, irregular movements, peristaltic rush, antiperistalsis, and finally, as the effect of the drug wears off, regular, slowly travelling peristalses. The latter alone were especially noted, since the mechanism of antiperistalsis and peristaltic rush is obscure.

Fig. 1 is a tracing from Cat No. 6, showing the passage of a peristaltic wave. The lever writing the lower line was attached 1 cm. above the line of section toward the duodenum, and the lever writing the upper line, 1 cm. below. Each curve shows a period of inhibition preceding the contraction. That this depression was not due to any movement of the intestine made by the tugging of the advancing wave is shown by its presence in nearly all of the tracings and by its disappearance at the lower lever in cases of block. The tracings show that each lever recorded first a wave of inhibition and then a contraction. The evidence, however, is not conclusive that the inhibitory part of the wave was actually conducted through the lesion. To avoid any disturbance due to the contraction above, the lower lever had to be placed too far away from the line of section to settle this important point. In work now undertaken we hope to clear the matter up by using the enterograph. At any rate, the fact seems beyond question that a peristaltic wave of some kind passed through the transected region.

WAYS IN WHICH A PERISTALTIC WAVE MIGHT PASS THE  
TRANSECTION.

There are a number of ways in which a peristaltic wave might bridge an injured portion of the intestine. A long reflex through the central nervous system, such as occurs normally in the œsophagus, might be developed in case of necessity. Reflexes through sympathetic ganglia of the abdomen would be another possibility, although the evidence seems against sympathetic ganglia mediating reflexes. Langley and Magnus<sup>7</sup> have also found that degeneration of the mesenteric nerves has no effect on intestinal movements. Muscular regeneration might occur at point of section and a myogenic form of conduction be developed. The passage might be made merely by mechanical tug of the muscle on one side stimulating the muscle on the other. Finally there might be a regeneration of Auerbach's plexus, which is the normal means of conduction.

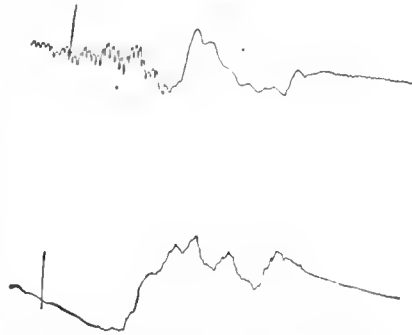

FIGURE 1. — Showing passage of peristalsis one hundred and thirty-seven days after transection of small intestine. Inhibition preceding contractions is to be noted.

To find which one of these mechanisms the intestine employs after transection now became the real object of the work. The central nervous system was eliminated by studying pithed animals. Four of the six cats had the cord destroyed from the cervical region down. In every animal waves still passed over the suture line. An attempt was made to extirpate the abdominal ganglia, but this proved a difficult procedure, particularly when it was desirable to keep the intestines in saline solution. Fortunately in Cat No. 6 a wave appeared in the loop after it had been removed and placed in salt solution. This definitely eliminated any reflex through extrinsic centres and showed that the mechanism was in the intestine itself.

The X-ray studies described in the protocol were now made to eliminate as far as possible any experimental errors and to decide to what

<sup>7</sup> LANGLEY and MAGNUS: *Journal of physiology*, 1905, xxxiii, p. 34.

extent mechanical tension was a factor in the passage of the wave. While it was easily conceived that mechanical stimulation from the impact of a mass of food might start a contraction simulating a true peristalsis, it seemed improbable that this method could account for rhythmical segmentation. Examinations were made repeatedly on Cat No. 2 in the hopes of finding the transected loop in a segmenting condition. As the protocol states, this search was rewarded by a clear picture of segmentation with the line of transection in the centre of the area. This was believed to be strong evidence of nervous regeneration, since the correlation necessary for the complex movements is generally attributed to the nerve plexus. Later work showed, however, that this evidence was not conclusive.

In all the cats of this series there was a slight increase in the diameter of the intestine above the line of section. In three this was rather marked. This hypertrophy is comparable to that found in experiments in which loops of the intestine are reversed in direction. The dilation is probably due to a temporary occlusion of the intestine as the result of the operation and also possibly to a temporary delay in the development of the conducting mechanism, whatever this may be.

The experiments gave some evidence that the power of conduction even at one hundred and thirty-seven to one hundred and ninety-five days was not as perfect as in the uninjured portions of the intestine. Often there was a noticeable delay in the passage of waves through the transected region and at times there was a complete block. These results seem to indicate that although conduction is reestablished the mechanism is not quite so efficient as formerly. This may mean that another mechanism less capable has taken over the function, or that the conductive tissue has not regenerated completely.

#### THE INTERVAL BETWEEN TRANSECTION AND THE RETURN OF CONDUCTION

The evidence presented above seems conclusive to us that there is a physiological restoration after transection of the small intestine. The next phase of the problem was to see how soon this regeneration might return. We were led to do this, since it seemed possible to gain some insight as to the mechanism involved in the conduction by learning the time at which waves began to pass through the transected loop.

Cats were again used, and the preliminary operation performed in the usual way. Silver wires were sewed in the stitches so that X-ray studies could be made. Protocols of these experiments will not be given. The technique was the same as in the preceding, and the only point of interest was to find how soon this passage occurred. Cat No. 10 after a quick recovery from the first operation was experimented on eighteen days later. Fig. 2 presents the results. This figure shows the pas-



FIGURE 2. — Showing passage of peristaltic waves in a cat eighteen days after transection of the intestine. Lever writing lower line is attached above toward the duodenum.

sage of two peristaltic waves, *A* and *B*, and a block of wave *C*. Wave *A* was preceded by inhibition. This does not show so clearly in the second wave, but it was present in other tracings. There can be no question of nerve regeneration here unless the plexus regenerates in a most remarkably short time. It would seem that the passage must either be due to muscular transmission or mechanical tension.

Cat No. 11 was examined nine days after the first operation. Here too there was passage of the peristaltic wave. Fig. 3 was made in this experiment. Cats Nos. 12 and 13 were tested at four and six days respectively, but the results were negative. Blocking was frequent. Fig. 4 taken from cat No. 13 illustrates this point.

Animals studied under the X-ray confirmed the above results. Cat No. 14 made a poor recovery, and successful observations were not made until the thirtieth day. Dark masses of food were seen passing through the transected loop. Careful watch was kept for rhythmical segmentation, but without result. Cat No. 15 proved a much more successful subject. The animal ate the morning after the first operation and showed absolutely no ill effects. A watch was kept every second day after feeding for the passage of peristaltic waves. On the eighth day peristaltic waves were seen to pass the line of transection, and later in the same day rhythmical segmentation was observed in the loop.

The last result was somewhat unexpected, and we have made no attempt to draw conclusions from it. There may have been no correlation through the line of section. As Dr. Carlson suggests, the chemical and physical consistency of the intestinal contents constitutes the adequate stimulus for segmentation movements. If such is the case, these movements might easily be set up in two adjacent areas separated by complete transection of the nerves and muscular coats. It would be



FIGURE 3. — Showing the passage of a peristaltic wave nine days after transection. Upper line from lever attached nearer duodenum.



FIGURE 4. — Showing block of peristalsis in a cat six days after transection of small intestine. Lower lever nearer duodenum.

impossible to tell whether the line of section merely passively divided two such regions or whether there was conduction and correlation.

Transections in a third series of animals, comprising six female dogs, were next studied. No X-ray examinations were made. Otherwise the experiments were carried out in the manner previously described. Dogs Nos. 5 and 6 differed from the others in having only the muscular coats transected.<sup>8</sup> This modification was made by Dr. Carlson to insure a more complete end to end anastomosis than is possible with a complete transection. The cut was made down to the mucosa and entirely around the intestine. The protocols of these experiments are similar to those already given and need not be repeated here. The dog's intestine responds much better to artificial stimuli than that of the cat, but to make the work uniform eserine was again used. Three of the dogs were kept one hundred and eighty days and three two hundred and forty days. Peristalsis was shown to pass the line of transection in each case. Fig. 5 shows the passage in one dog two hundred and forty days after transection. A peristaltic wave may pass the transection by simple mechanical means.

<sup>8</sup> The transections in these animals were made in Chicago by Dr. Carlson and Dr. Werelius, whom I wish to thank for their kindness.



Thus far the work offered practically nothing in solution of our original thesis, the regeneration of Auerbach's plexus. However an advance has been made in discovering that physiological regeneration in the intestine is no proof of anatomical regeneration, so far at least as the nerve plexus is concerned. At first it was thought that the passage of a wave across the suture line would be ample proof of nervous regeneration. Later, when this idea was given up, it seemed equally certain that rhythmical segmentation would be sufficient evidence. It has been shown how this too may take place long before the nervous mechanism could possibly grow anew. All of this, to be sure, by no means disproves a regeneration of Auerbach's plexus. This may take place at the proper time and under the proper conditions. It does show that until recovery is complete the intestine has other mechanisms that enable it to carry on its usual motor function. The real proof for regeneration must be sought by histological methods.

An attempt was made to find exactly how the early conduction across the injured portion took place. It seemed obvious that it was a case either of mere mechanical tension or of conduction through the muscular tissue. As will be described later, the histological studies showed that the longitudinal coat regenerated very rapidly, and for a time this means of conduction seemed more probable than any other. The matter was finally decided by the following experiment. A cat under ether was arranged in the usual way for studying peristalsis. At a convenient point in the small intestine the muscular coats were transected, the mucosa being left intact beneath. This was done carefully, the muscular coats being divided by cutting a ring around the intestine. The continuity of the intestine was thus preserved by the mucosa and submucosa alone. Five centimetres above the ring a slit was made in the intestine and a similar one an equal distance below. A bolus of cotton smeared with vaseline was inserted in the upper slit. Peristaltic waves were produced by the injection of eserine. The bolus was soon carried

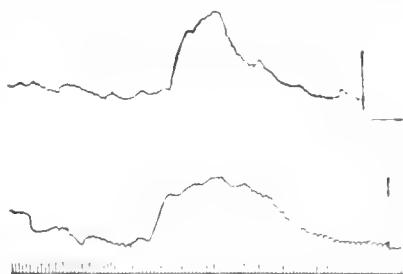

FIGURE 5. — Showing passage of peristalsis in dog two hundred and forty days after transection. Lever writing lower line nearer duodenum.

down the intestine by a peristaltic wave, and forced past the narrow ring which was stripped of its muscular coats. With little or no delay a wave appeared on the lower side of the transection and the bolus was crowded down the intestine until it appeared at the lower opening. This result was obtained repeatedly.

In this experiment there could be no question of muscular conduction. Neither does it seem possible that the mucous or submucous coat could be concerned in the conduction of the impulse. Magnus,<sup>9</sup> it will be remembered, found that the mucosa and submucosa gave no movements and took no part in the general motor functions of the intestine. This experiment seems clearly to demonstrate that a peristaltic wave may be conducted across a gap in the intestine by simple mechanical means. The tug of the contracting musculature above the line of transection and the impact of the bolus below is sufficient to set up a contraction, and the wave continues downward.

This is a striking example of mechanical correlation. It illustrates the ability of the body to develop or make use of other mechanisms when any given one fails. We believe this method of conduction is the one used by the intestine after transection until the continuity of the plexus, the normal mechanism, is restored, provided that is ever possible. The rather frequent occurrence of delays at the line of suture may now be explained. Mechanical stimulus is not the natural one for the intestine, and it does not respond as quickly or as accurately to it. The dilation often occurring above the line of transection may be due in part to the slightly diminished efficiency at this point.

#### HISTOLOGICAL STUDIES.

So far as our original problem is concerned, the most important result obtained is that the passage of the peristaltic wave across the intestine is not a proof of the continuity of the nerve plexus. The decision in regard to Auerbach's plexus must be made on purely histological grounds. For this purpose all of the transected portions in the preceding experiments were studied.

Methylene blue and gold chloride were used to stain the nerve plexuses. Methylene blue proved difficult to handle in the large pieces, and so most of the work was done with gold chloride. The tissues were placed

<sup>9</sup> MAGNUS: *Archiv für die gesammte Physiologie*, 1904, cii, p. 349.

in 1/2 per cent arsenic acid thirty minutes, in gold chloride thirty to forty-five minutes, reduced in 1 per cent arsenic acid over the water bath for ten to fifteen minutes, and preserved in glycerine. To study the muscular coats pieces were fixed in Zenker's fluid, washed, dehydrated, embedded in paraffin, sectioned, and stained with Mallory's muscle stain.

A careful study was made of the regeneration of the different coats of the intestine after transection. At the time considerable importance was attached to the rapidity with which the muscular coats regenerated, since it was believed that they might be the agents of conduction. On finding that the passage was at first due to mechanical factors this part of the work became of secondary importance. It is believed worth while, however, to give the general results.

The work of Mall<sup>10</sup> on the healing of intestinal sutures is well known, and we can confirm him in most details, except in regard to the length of time required for regeneration. Mall found complete regeneration in dogs only at about sixty days. Recovery in cats is much more rapid. Fig. 6 is a more or less diagrammatic longi section through the line of transection in a nine-day cat. Regeneration is not yet complete, but the process is well on its way. The longitudinal muscular coat at least has regenerated. The circular coat is separated by a heavy band of connective tissue which persists indefinitely. The submucosa has reunited, and new villi and glands are being formed in the injured mucosa. The anastomosis in this case seems to have been well made, and the rapid growth is perhaps due somewhat to this fact.

In every case the regeneration begins with a fibrous union of the serous surfaces. This may take place in a few hours. The longitudinal muscular coat regenerates quicker than any other part except the serosa. Protruding parts of the mucosa are destroyed. The circular muscular coat, strictly speaking, does not regenerate, since it has been

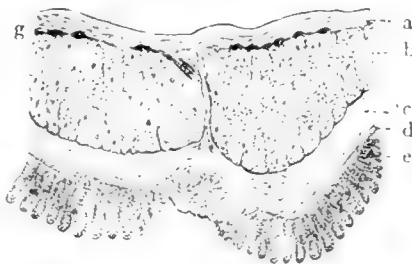

FIGURE 6. — Longi section through line of transection of cat's intestine. Nine days after operation. *a*, longitudinal muscular coat; *b*, circular muscular coat; *c*, submucosa; *d*, muscularis mucosa; *e*, mucosa with villi and glands; *b*, mucosa disintegrating at point of anastomosis; *g*, ganglionic masses of Auerbach's plexus.

<sup>10</sup> MALL: Johns Hopkins Hospital reports, 1896, i, p. 376.

merely separated by the cut, its fibres running parallel to the plane of the section.

Fig. 7 illustrates a section through a six-day stage. The longitudinal muscular coat has not yet regenerated. At *g* and *h* outgrowing projections may be seen which are to make the connection. In many

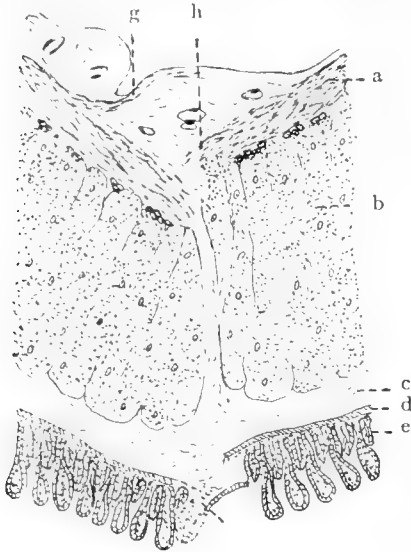

FIGURE 7. — Longi section through line of transection in a cat six days after operation. *g*, regenerating portion of longitudinal muscular coat; *h*, portion of growing muscle carried across by the serosa. Other letters the same as in Fig. 6.

cases the junction between the separated portions of the longitudinal coat is made by a projection taking the course of *h* in Fig. 7. These sections are of importance in showing the relation the ganglionic masses of Auerbach's plexus bear to each other after the intestine has been transected.

Gold chloride, as every one knows who works with it, is more or less capricious. Animals also vary in the ease with which their tissues are impregnated. Auerbach's plexus in the cat is stained with some difficulty. In our work we were under the further necessity of having the stain appear at a given point. For these reasons the gold chloride stains on the first series of cats were unsatisfactory. A large piece

of the intestine with the scar in the centre was stained. The mucosa was either left intact or carefully removed. Adhesions on the serosa were left, since their removal might have damaged the longitudinal coat and the plexus lying immediately beneath. The idea was to stain the plexus on each side of the scar and study to see if any fibres passed across. In the cat intestines the stain did not take uniformly over the entire piece. While we did not demonstrate any regeneration, we feel the results in this first series have little weight, since the stain might have failed exactly where needed.

Auerbach's plexus in the dog stains rather easily, and in the series of dogs from one hundred and eighty to two hundred and forty days

after transection good stains were secured in each case. Six different intestines were studied. The results in the first five of these were negative. The first four were from dogs in which the intestine had been cut entirely across. Dogs Nos. 5 and 6 had only the muscular coats transected. In the first four little could be seen in the scar tissue. Figs. 6 and 7 show how the connective tissue develops between the circular coats and even between the serosa and the longitudinal muscular coat. In the dog this is sometimes very pronounced, especially in those cases in which the transection has been made entirely across the intestine and the anastomosis has been somewhat inaccurate in placing the various layers end to end. Under the influence of the gold this scar tissue darkens, and one can scarcely decide whether or not nerve fibres penetrate it.

Dogs Nos. 5 and 6 were more favorable for study. In these there was scarcely any thickening at the suture line. The layers had been nicely approximated and scar tissue was at a minimum. Fig. 8 is from the line of transection in Dog No. 5. A slight thickening at the exact line of section is evident. On either side (to be exact,  $1\frac{1}{2}$  mm.) are seen the blunt ends of the large strands composing the plexus. On a few of these ends, such as *b*, are faint suggestions of outgrowing fibres, but they cannot be traced any distance. No fibres appear anywhere between or across the scar. The plexus is stained even to fine details in all parts of the preparation, except the blank area on either side of the scar. The nerve cells can be distinguished in the ganglionic masses. It is clear that there has been no regeneration of the plexus.

Dog No. 6 was kept one hundred and eighty days after the circular suture was made. Fig. 9 shows the results of the gold chloride stain. Superficial connective tissue adhesions were practically absent in this specimen. The plexus stained well in all parts of the preparation. The

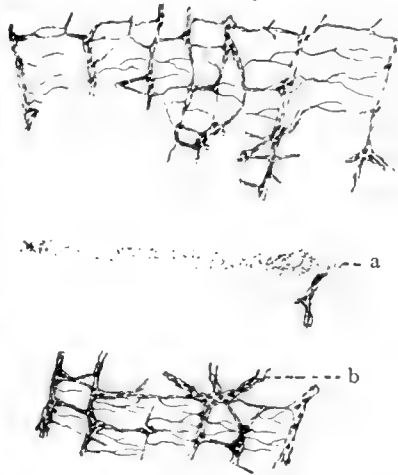

FIGURE 8.—Gold chloride stain of transected area in dog two hundred and forty days after operation. *a*, line of transection; *b*, end of strand of the plexus.

cut ends of the large plexus strands in this case are not blunt as in the previous one. From the severed ends fibres pass out into the scar area, and at least five of these fibres in the one small region drawn can be seen to pass across and enter the strands on the other side. Many other processes pass out into the scar tissue and are lost to view. High powers of the microscope show that these fibres are not mistaken blood vessels, but real non-medullated nerve fibres.

At first it was thought that these fibres might have been some lying deep in the muscular layers and thus escaped section. But this could not be, since on cutting the muscular coats transversely they immediately pull apart and expose the mucosa below. Fibres could not possibly escape both rupture and cutting. Besides the processes in question are well toward the upper surface of the specimen, and the large strands show plainly that the transection was complete. We have here undoubtedly a good example of nerve regeneration.

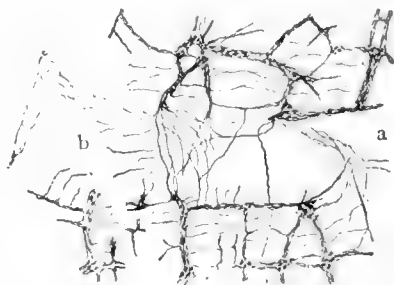

FIGURE 9. — Gold chloride stain of transected area in dog one hundred and eighty days after transection. *a* to *b* marks the line of transection.

A more difficult problem is to determine the origin of the regenerating fibres. Unfortunately very little work seems available on the nervous elements constituting Auerbach's plexus. That extrinsic nerves enter the plexus is well known, but what becomes of them is by no means clear. Dogiel,<sup>11</sup> Cajal,<sup>12</sup> and others believe that the plexus contains two kinds of fibres. These are, first, those coming from ganglionic cells of the plexus and, second, certain "passage fibres" whose origin is obscure. The passage fibres may be merely unusually long axones from ganglionic cells or they may be postganglionic fibres from extrinsic abdominal nerve centres. These passage fibres are of small diameter, less numerous than the others, and characterized by varicosities.

Gold chloride preparations do not allow one to discover the origin of the fibres crossing the scar. The fibres can be easily traced into one of the large plexus strands, and the nerve cells in these strands can be dis-

<sup>11</sup> DOGIEL: *Anatomische Anzeiger*, 1895, x, p. 517.

<sup>12</sup> CAJAL: *Structure du système nerveuse*, 1895, p. 140.

tinguished, but it would be hazardous to say just where the processes end. We believe, however, that the fibres are intrinsic and are processes of the ganglionic cells constituting Auerbach's plexus. The chief evidence for this belief lies in the fact that the regenerating fibres are too numerous to be considered passage fibres. Dogiel and Cajal do not state the relative number of the latter, but their figures show only a few in each strand. While only five or six fibres can be traced completely across the scar in our preparation, Fig. 9 shows how large numbers pierce well into the scar tissue. At *a* is a large number of these fibres so crowded that they resemble an entire strand of the plexus. A second reason for believing that the fibres under question are not passage fibres is that their course is direct and they show none of the sinuosities of such axones.

As the matter stands, we believe we have definitely proved the regeneration of certain fibres in Auerbach's plexus. There may still be some question as to the origin of these fibres, but it seems reasonably clear that they are nerve processes from cells in the plexus itself.

Why was there no regeneration in any of the other animals studied? An answer to this question can only be problematical, remembering at the same time that one positive experiment is worth any number of negative ones. There is no doubt that an entire transection of the intestine is unfavorable to regeneration. Scar tissue is extensively produced, and this is doubtless difficult to penetrate. What is even more important is that in this procedure only occasionally are the layers closely approximated in the anastomosis. A condition shown in Fig. 7 is usually produced. The longitudinal coat reunites by a new path (see *b* in Fig. 7), and the cut ends of the plexus are so far removed and separated by the muscular coats that regeneration could hardly be expected. Cutting only the muscular coats allows a close approximation of the ends of the plexus, and conditions are far more favorable. Age may also be a factor. One would expect regeneration to occur more easily in the young than the old. This factor is being further investigated.

The regeneration of Auerbach's plexus suggests that this may occur in other plexuses, and thus opens up a new line of investigation of the heart. Erlanger<sup>13</sup> has produced artificial heart-block in dogs by crushing the bundle of His with the clamp especially devised for that purpose. The dogs were allowed to recover and lived two hundred and

<sup>13</sup> ERLANGER, BLACKMAN, and CULLEN: This journal, 1908, xxi, p. xxviii.

sixty-nine and two hundred and seventy-eight days in a state of chronic heart-block. The same author has recently reported<sup>14</sup> separating a portion of a dog's auricle from the remainder of the musculature by crushing. Two hundred and sixty-eight days after this operation the heart was exposed and the portion isolated by crushing stimulated electrically without the rest of the heart being affected. Judging from our results, one might expect regeneration of plexuses in heart tissue. The operative methods described above should be duplicated and followed by a careful study of the plexuses in the heart musculature. This will be a difficult problem, considering the unsettled state of our knowledge concerning nerves in the heart, but it is being undertaken with some prospect of ultimate success. It may yet be possible to subject the neurogenic and myogenic theories to a crucial test in the vertebrate heart.

#### SUMMARY.

1. The small intestine was transected in cats and dogs in order that the regeneration of Auerbach's plexus might be tested.
2. Physiological restoration, as determined by the passage of peristalsis across the lesion and by segmentation movements, has been demonstrated from the eighth day.
3. This physiological restoration is not a sufficient test for the regeneration of the nervous mechanism in the intestine.
4. There is no reason for doubting that the continuity of Auerbach's plexus is necessary for the normal intestinal movements, but other methods may be employed when the nervous mechanism is injured. In the cat it has been definitely shown that after transection the peristaltic wave may be conducted by mechanical means. A stimulus is found in the tug on the musculature or on the nervous elements by the contracting ring above the section and in the impact of the bolus.
5. The longitudinal coat of the cat's small intestine may regenerate in from seven to nine days after a circular suture.
6. In one of six dogs a regeneration of Auerbach's plexus was shown one hundred and eighty days after transection of the circular and longitudinal coats of the intestine.

<sup>14</sup> ERLANGER: This journal, 1909, xxiv, p. 375.



# ACAPNIA AND SHOCK. — V. FAILURE OF RESPIRATION AFTER INTENSE PAIN.

By YANDELL HENDERSON.

(WITH THE COLLABORATION OF FRANK ELMER JOHNSON AND CHARLES WILLIAMS COMFORT.)

[From the Physiological Laboratory of the Yale Medical School.]

## CONTENTS.

	PAGE
I. Acapnia as a factor in the after-effects of pain . . . . .	385
II. The influence of ether in preventing apnœa . . . . .	387
III. Apnœa vera after pain-hyperpnœa . . . . .	389
IV. The usual form of death in shock . . . . .	395
V. Fatal apnœa in man . . . . .	399
VI. Conclusions . . . . .	401

### I. ACAPNIA AS A FACTOR IN THE AFTER-EFFECTS OF PAIN.

IN a previous paper<sup>1</sup> it was shown that by a voluntary increase of the rate and depth of breathing a normal man can induce in himself many of the symptoms of that form of shock which follows intense pain. It was shown also that excessive artificial respiration produces similar effects in animals, and that the immediate cause of these disturbances of function is acapnia. In particular the cessation of breathing which follows both of these forms of hyperpnœa, as Miescher, Mosso, Haldane and his co-workers, and others have demonstrated, is due to the diminution of the CO<sub>2</sub> content of the blood. Failure of respiration thus induced is termed apnœa vera.

The object of this paper is to compare the effects of the hyperpnœa induced by intense afferent irritations with those of forced breathing and excessive artificial respiration. The comparison will show that the former are identical with the latter in all of the following essential points:

<sup>1</sup> HENDERSON, Y.: This journal, 1910, xxv, p. 310.

1. Apnœa as a consequence of hyperpnœa.<sup>2</sup>
2. Cheyne-Stokes breathing after apnœa has been prolonged until partial asphyxia has occurred.<sup>3</sup>
3. Prolongation of apnœa by a jet of oxygen into the bronchi.<sup>4</sup>
4. Restoration of normal breathing by administration of CO<sub>2</sub> during apnœa.<sup>5</sup>
5. Prevention or abbreviation of apnœa by moderate ether anæsthesia.<sup>6</sup>
6. Neutralization of this ether-excitement by morphin.<sup>7</sup>
7. Slowing of the heart, simulating vagus inhibition, in the fifth minute of apnœa.<sup>8</sup>
8. Progressive diminution in the amplitude of the heart beat after the fifth minute of apnœa, ending in death from oxygen starvation of the heart in the eighth minute of apnœa.<sup>9</sup>

On all these points it is essential that the reader should compare the data of artificial shock in the previous paper with the results to be here described in order to estimate fairly the validity of the theses: that the after-effects of pain are mainly due to acapnia, and especially that failure of respiration in shock is apnœa vera.

Before proceeding further it is necessary to state the significance of the term "pain-hyperpnœa" in these experiments for the sake both of logic and of humanity. The word "pain" denotes injurious irritation of afferent nerves or sense organs. It likewise usually connotes the mental state of suffering conditioned thereby. In this paper the word is used without this connotation. In all of our experiments upon the effects of intense and prolonged afferent irritation, the subjects (dogs) were at all times sufficiently drugged to be unconscious. The majority of these animals ultimately exhibited the symptoms of shock. It appears, therefore, that the consciousness of suffering is a mere accompaniment and not a causal element in the development of shock. \*

In like manner it appears from these experiments that the activities of the centres in the spinal bulb (respiratory, cardiac, and vaso-motor) induced by pain are negligible factors in the after-effects of pain, except as these activities alter the blood gases. Even after prolonged stimu-

<sup>2</sup> *Loc. cit.*, p. 312.

<sup>4</sup> *Loc. cit.*, p. 329.

<sup>6</sup> *Loc. cit.*, p. 331.

<sup>8</sup> *Loc. cit.*, p. 327.

<sup>3</sup> *Loc. cit.*, p. 328.

<sup>5</sup> *Loc. cit.*, p. 330.

<sup>7</sup> *Loc. cit.*, p. 333.

<sup>9</sup> *Loc. cit.*, p. 326.

lation with continuous hyperpnœa and elevated arterial pressure, the bulbar centres exhibit no alteration in functional capacity, aside from the effects of acapnia. They are neither fatigued by activity, nor depressed by the flood of afferent irritations. Against this opinion might be adduced the facts that the animals in our experiments were under morphin and ether, and that these drugs greatly diminish the sensitiveness of the bulbar centres. In fact, according to the acapnia hypothesis, anæsthesia tends to prevent shock because it diminishes the responsiveness of respiration to pain. Our experiments do not completely reproduce the conditions to which a man is exposed when his legs are crushed by machinery — without anæsthetics. Nevertheless, we have found that with most of our dogs, during complete anæsthesia, it was possible by carefully adjusted irritation to force the respiratory centre into intense and continuous activity for periods of fifteen to thirty minutes.

In those cases in which the quantity of morphin and ether, or the individual susceptibility of the subjects to these drugs, prevented hyperpnœa, none of the symptoms of shock developed. Even when the breathing was most vigorous and best sustained it is probable that the ventilation was less than it would be in an unanæsthetized subject. On the same day with one of our experiments the writer observed a man immediately after a fall in which he sprained an ankle. During the succeeding five minutes his hyperpnœa was more active than we were usually able to induce in the anæsthetized subjects of our experiments. Thus, if we have interpreted our data correctly, it would seem logical to expect that a man might withstand prolonged torture without developing shock, although with no less consciousness of suffering, if he were breathing an atmosphere containing six or seven per cent of  $\text{CO}_2$ , or if his hyperpnœa were performed through a tube or into a bag. This view is, of course, as yet merely our working hypothesis. It is based upon the data reported in the first and third papers of this series.<sup>10</sup>

## II. THE INFLUENCE OF ETHER IN PREVENTING APNŒA.

In the presentation of our experimental data we shall describe first the conditions which tend to prevent apnœa; next the experiments in which apnœa occurred, but the subjects recovered; then the

<sup>10</sup> HENDERSON, Y.: This journal, 1908, xxi, pp. 148-155, and 1909, xxiv, p. 82.

crucial cases in which apnœa was prolonged until death; and finally the conditions which accelerate the fatal termination of apnœa vera.

In experiments on twenty-five dogs the sensory irritations employed consisted of electrical or mechanical stimulation of the central end of the exposed and divided sciatic nerve or nerves. In five of these experiments the animals were anæsthetized with ether, but no morphin was administered. The results afford a notable exception to the law that respiration normally ceases when the  $\text{CO}_2$  content of the blood is diminished. This topic will be discussed more fully in a later paper of this series. In two of these cases the breathing continued without a pause after the irritation was ended. In the other three an abnormally brief apnœa occurred. During the hyperpnœa, in spite of continual administration of ether, more of the anæsthetic was wasted by the forcible expirations than was absorbed by the lungs. At the end of the period of irritation the dogs were left in that peculiar stage of anæsthesia which is characterized by excessive respiratory activity. In this state of ether excitement the respiratory centre behaves like an engine that has lost its governor and "runs away." In spite of an increasing acapnia and long after afferent stimulations had ceased, the centre, instead of relapsing into apnœa, maintained hyperpnœa. The animals were entirely unconscious. Some of them shivered vigorously.<sup>11</sup> They afford illustrations of that influence of ether as a "respiratory stimulant" which prevents failure of respiration on the operating table, and — according to the acapnia theory — is one of the principal causes of "post-operative shock."

In Fig. 1 is reproduced a part of the graphic record of one of the experiments under ether without morphin. One sciatic nerve was cut and the central end stimulated electrically. Vigorous hyperpnœa was thus induced and maintained for twenty minutes. When the stimulation was stopped, apnœa occurred, but lasted for only one minute. Then spontaneous breathing recommenced, although the blood contained only half of the normal content of  $\text{CO}_2$ . In three minutes more the respiration developed into typical ether-hyperpnœa accompanied by violent shivering. The gases of the arterial blood were determined by the method of Barcroft and Haldane.<sup>12</sup> The results of these analyses are given in Table I.

<sup>11</sup> Compare the preceding paper of this series, loc. cit., pp. 320 and 331.

<sup>12</sup> BARCROFT and HALDANE: *Journal of physiology*, 1902, xxviii, p. 234.

TABLE I.

EXPERIMENT OF MAY 29, 1909. DOG UNDER ETHER WITHOUT MORPHIN.

(See also Fig. 1.)

Duration of pain-hyperpnœa . . . . .	20 min.
Duration of apnœa . . . . .	1 min.
Arterial blood gases before hyperpnœa (volumes per cent) . . . . .	15.3 O <sub>2</sub> 35.1 CO <sub>2</sub>
One minute after the return of breathing (volumes per cent) . . . . .	16.0 O <sub>2</sub> 22.9 CO <sub>2</sub>

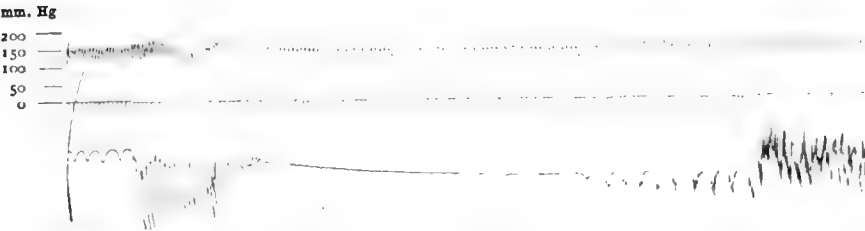

FIGURE 1. — Experiment of May 29, 1909. Dog under ether without morphin. Arterial pressure recorded by a Hürthle manometer connected with the carotid. Time in seconds. Respiration recorded by means of the apparatus shown in Fig. 10 of the previous paper, *loc. cit.*, p. 331. Down strokes are inspirations. At the three breaks in the curves the record is omitted for one, twenty, and two minutes respectively. The record shows four normal breaths; then hyperpnœa for twenty minutes during electrical stimulation of the sciatic nerve. Thereafter apnœa for only one minute, followed by ether-hyperpnœa and acapnial shivering. For blood gases see Table I. Fig. 1 is about one third the original size.

In Fig. 2 is shown an arrangement which proved satisfactory for supplying sufficient ether vapor during the periods of hyperpnœa without causing the animals to re-breathe their expired air.

### III. APNŒA VERA AFTER PAIN-HYPERPNŒA.

Throughout this series of experiments a twofold difficulty was encountered. On the one hand it was necessary to avoid such profound narcosis as would render the respiratory centre insensitive to afferent irritation and thus prevent acapnia. On the other hand it was found to be equally essential that sufficient morphin should be administered to overcome ether excitement and the abnormal abbreviation of apnœa. Various dosages of morphin were tried. With more than 0.02 gm. morphin sulphate per kilo body weight and chloroform or liberal ether administration, the most intense irritations failed to induce vigorous hyperpnœa and acute acapnia. With less than 0.01 gm. morphin

plus ether, the animals drew deep gasping inspirations at intervals during apnoea, and the oxygen thus supplied to their blood prevented asphyxia.

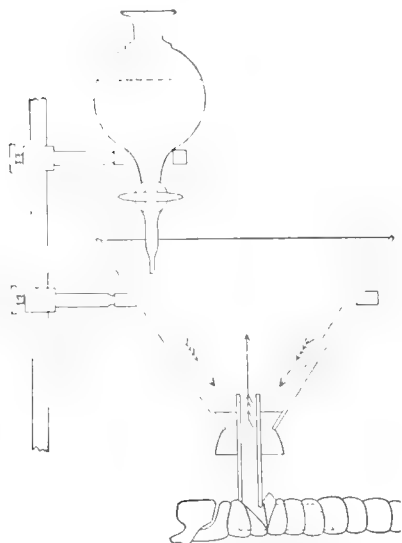

FIGURE 2. — Etherizing funnel used to supply ample ether vapor during hyperpnœa, without any re-breathing of the expired air. The diagram shows the trachea with a short bent cannula inserted, a 30 cm. glass funnel with the drip tube broken off, and a rubber stopper holding the cannula in the neck of the funnel. The dotted line indicates the filter paper with which the funnel was lined, and upon which ether was dropped. The inverted arrows show the movement of the vapor, the upright arrow that of the expired air.

The record of an experiment of the latter character is reproduced in Fig. 3. The analytical data are shown in Table II. In this case pain-hyperpnœa was maintained for twenty-five minutes. During the first minute thereafter gasps occurred at intervals of five to seven seconds. Apnoea followed, but lasted for only two minutes with slight trembling. Then isolated gasps reappeared at intervals of fifteen to thirty seconds. Without these spasmodic inspirations the animal would probably have died of asphyxia. Six minutes after the termination of the pain the animal developed a rapid irregular breathing punctuated by gasps. Such observations suggest that ether in moderate amounts acts in somewhat the same manner as the acidosis substances (*e. g.*, lactic acid, acetone, etc.) in stimulating the respiratory centre. The blood gas analyses of this experiment are contained in Table II.

TABLE II.

EXPERIMENT OF MAY 19, 1909. DOG UNDER MORPHIN SULPHATE (0.006 GM. PER KILO) AND ETHER. (See also Fig. 3.)

Duration of pain-hyperpnœa . . . . .	25 min.
Duration of apnoea interrupted by gasps . . . . .	6 min.
Arterial blood gases before hyperpnœa (volumes per cent) . .	14.0 O <sub>2</sub> 36.9 CO <sub>2</sub>
At the end of hyperpnœa . . . . .	15.8 O <sub>2</sub> 27.7 CO <sub>2</sub>
During shallow irregular breathing eight minutes later . . . .	10.9 O <sub>2</sub> 32.4 CO <sub>2</sub>

The best conditions for these experiments were found to be afforded by a dosage of 0.015 gm. morphin sulphate per kilo (given subcutaneously half an hour beforehand) and administration of ether by means of the funnel shown in Fig. 2. The observations obtained on twelve dogs under these conditions accord even in minute details with those recorded after artificial respiration in the preceding paper of this series. The experiments fall naturally into three groups: (1) Those in which a relatively brief period of hyperpnœa induced only a moderate degree of acapnia, and in which the return of breathing depended solely upon re-accumulation of CO<sub>2</sub>. (2) Those in which more prolonged hyperpnœa and more intense acapnia caused a continuance of apnœa until the oxygen store of the tissues was exhausted, and in which the resulting asphyxial acidosis contributed to the restoration of breathing. (3) Those in which the CO<sub>2</sub> content of the body was so far depleted by prolonged hyperpnœa that apnœa of fatal, or almost fatal, duration ensued. The data of these three groups were as follows:

1. After periods of pain-hyperpnœa of five to nine minutes, apnœa for two to three minutes occurred. When breathing recommenced, the blood gas analyses showed that the CO<sub>2</sub> had re-accumulated almost to the normal quantity. Such cases exhibited no subsequent periodic



FIGURE 3. -- Experiment of May 19, 1909. Dog under morphin sulphate (0.006 gm. per kilo) and ether. Same methods of recording as in Fig. 1. At the breaks in the curves the record is omitted for four, twenty, and two minutes respectively. At first normal breathing and pressure pulse. The irregularities in the pneumograph line were due to trembling. Then pain-hyperpnœa for twenty-five minutes (from  $\alpha$  to  $\omega$ ) induced by rubbing the sciatic nerve. Thereafter gasps for one minute, apnœa and trembling for two minutes, renewed gasps at intervals of twenty to thirty seconds. Six minutes after termination of pain, rapid irregular breathing punctuated by gasps. Without the gasps the animal would probably have died of asphyxia during apnœa. For blood gases see Table II. Fig. 1 is about one fourth the original size.

breathing. The analytical data of two typical examples are contained in Table III.

TABLE III.

EXPERIMENTS OF MAY 10 AND 15. DOGS UNDER MORPHIN SULPHATE  
(0.015 GM. PER KILO) AND ETHER.

	May 10		May 15	
Duration of hyperpnœa . . . . .	6 min.		7.5 min.	
Duration of apnœa . . . . .	2.5 min.		3 min.	
Blood gases at the beginning . . . . .	17.0 O <sub>2</sub>	44.2 CO <sub>2</sub>	18.5 O <sub>2</sub>	47.7 CO <sub>2</sub>
At the end of hyperpnœa . . . . .	17.5 O <sub>2</sub>	26.0 CO <sub>2</sub>	19.4 O <sub>2</sub>	27.1 CO <sub>2</sub>
At the end of apnœa . . . . .	3.9 O <sub>2</sub>	40.5 CO <sub>2</sub>	9.1 O <sub>2</sub> <sup>1</sup>	39.2 CO <sub>2</sub>
Two minutes after return of breathing . . . . .			8.2 O <sub>2</sub>	45.7 CO <sub>2</sub>

<sup>1</sup> The dog had already drawn one breath when the blood sample was taken.

2. After pain-hyperpnœa from fifteen to twenty minutes the subsequent apnœa lasted from four to five minutes. The relatively earlier return of breathing in these cases was largely due to acidosis, for the CO<sub>2</sub> content of the blood at the end of apnœa was still much less than normal. An interval of five to ten minutes of typical Cheyne-Stokes breathing followed the apnœa.<sup>13</sup> The record of the respiration of one of these cases is reproduced in Fig. 4, and the analytical data of this and another similar experiment are contained in Table IV. When a small rubber tube was inserted in the trachea down to the bifurcation of the bronchi and a mild jet of oxygen was maintained during apnœa, the return of breathing was markedly retarded because of the oxidation of the acidosis substances. These observations were precisely similar to those described after excessive artificial respiration in the preceding paper. When oxygen was not given during apnœa, but was administered soon after the return of breathing, the animals relapsed into apnœa. Part of the record of one of these experiments is reproduced in Fig. 5.

When a gentle stream of CO<sub>2</sub> from a Kipp generator was passed into the bronchi during apnœa, the animals promptly began to breathe. A similar result was obtained when a few cubic centimetres of CO<sub>2</sub> were placed in the etherizing funnel and the thorax was squeezed once or twice by hand. Part of the record of an experiment of this sort is reproduced in Fig. 6. So long as CO<sub>2</sub> was supplied the animals continued to breathe. After it was shut off they

<sup>13</sup> For a discussion of Cheyne-Stokes breathing under such conditions see the preceding paper of this series, *loc. cit.*, p. 328.



relapsed into apnœa. Without CO<sub>2</sub> artificial respiration excited no response. These observations demonstrate that acapnia is the cause of failure of respiration after pain-hyperpnœa, and they suggest a therapy.

TABLE IV.

EXPERIMENTS OF JUNE 18 AND 22. DOGS UNDER MORPHIN SULPHATE  
(0.015 GM. PER KILO) AND ETHER.

	June 18	June 22
Duration of hyperpnœa . . . . .	20 min.	20 min.
Duration of apnœa . . . . .	5 min.	4.5 min.
Blood gases at the beginning . . . . .	22.1 O <sub>2</sub> 46.8 CO <sub>2</sub>	19.0 O <sub>2</sub> 45.0 CO <sub>2</sub>
At the end of hyperpnœa . . . . .	23.2 O <sub>2</sub> 17.0 CO <sub>2</sub>	
At the end of apnœa . . . . .	4.0 O <sub>2</sub> 28.5 CO <sub>2</sub>	
During Cheyne-Stokes breathing . . . . .	26.3 O <sub>2</sub> 26.7 CO <sub>2</sub>	16.2 O <sub>2</sub> 34.3 CO <sub>2</sub>



FIGURE 4.—Experiment of June 22, 1909. The dog had performed pain-hyperpnœa for twenty minutes and had then sunk into apnœa for four and one half minutes. The part of the record of respiration here reproduced is that which followed apnœa. It shows the single gasp and Cheyne-Stokes periodicity, indicative of the interaction of acapnia and asphyxial acidosis. Finally uniform breathing returned. For blood gases see Table IV.

3. When vigorous pain-hyperpnœa was maintained for twenty to thirty minutes, the animals sank thereafter to the point of death before

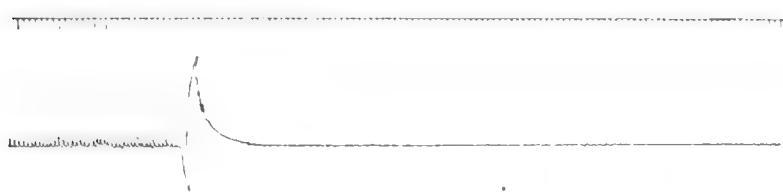

FIGURE 5.—Record of renewal of apnœa after one deep inspiration of oxygen gas. The dog had passed through twenty minutes of pain-hyperpnœa, four minutes of apnœa, and was breathing in a quick shallow manner. A bag containing oxygen was attached to the trachea, and the animal happening to gasp an instant later, the asphyxial substances in the blood were oxidized and apnœa for eighty seconds followed.

the return of respiration. Six dogs were thus treated. Three recovered and three died. The record obtained from one of the recoveries is reproduced in Fig. 7. It shows at first the normal respiration and pressure pulse; then for twenty minutes hyperpnoea, tachycardia, and increased arterial pressure. The latter conditions were induced by



FIGURE 6. — Record of renewal of breathing induced by air containing  $\text{CO}_2$ . The dog had been in pain-hyperpnoea for twenty minutes, and in apnoea for one minute. A few c.c. of  $\text{CO}_2$  gas from a Kipp generator were placed in the etherizing funnel (Fig. 2). A single artificial respiration was produced by squeezing the thorax by hand. Immediately after the gas had entered the lungs spontaneous breathing occurred. The supply of  $\text{CO}_2$  was stopped and apnoea recurred for one minute and a half. Squeezing the thorax without  $\text{CO}_2$  elicited no response.

electrical stimulation of the central end of a cut sciatic nerve. When the stimulation ceased, the dog passed immediately into apnoea. After three and a half minutes the heart slowed down until it was beating only twice in a half minute, and arterial pressure fell to 20 mm. of mercury. After four and a half minutes of apnoea the heart began to beat at a rate of 35 per minute, and arterial pressure partially recovered. Two minutes later the rate had dropped to 10 per minute, and the pressure had fallen correspondingly. Then, after a total apnoea of six and a half minutes,

two inspiratory gasps occurred. These sobs or sighs were repeated at gradually decreasing intervals for five minutes, with a corresponding acceleration of the heart rate, and rise of arterial pressure. Periodic respiration for five minutes and finally normal breathing followed. The analytical data of this experiment and another similar to it are shown in Table V.

TABLE V.

EXPERIMENTS OF MAY 21 AND JUNE 23. DOGS UNDER MORPHIN SULPHATE (0.015 GM. PER KILO) AND ETHER. (See also Fig. 7.)

	May 21	June 23
Duration of pain-hyperpnoea . . . . .	20 min.	30 min.
Duration of apnoea . . . . .	6.5 min.	11 min. <sup>1</sup>
Blood gases at the beginning . . . . .	16.3 $\text{O}_2$ 37.2 $\text{CO}_2$	14.6 $\text{O}_2$ 42.3 $\text{CO}_2$
At the end of pain-hyperpnoea . . . . .		14.8 $\text{O}_2$ 12.4 $\text{CO}_2$
After 4.5 minutes of apnoea . . . . .	2.1 $\text{O}_2$ 28.4 $\text{CO}_2$	0.0 $\text{O}_2$ 15.9 $\text{CO}_2$

<sup>1</sup> The animal drew a single deep inspiratory gasp after five minutes of apnoea.

The three dogs which died afford a crucial demonstration of fatal apnoea vera as a consequence of pain-hyperpnoea. The behavior of two of them was in all respects identical with that described in the preceding paragraph and shown in Fig. 7, except that no gasps occurred. Their hearts came nearly to a standstill after five minutes of apnoea, but resumed a slow full beating during the sixth minute. Thereafter the amplitude of the pulse steadily diminished, without change of rate, until the hearts stopped toward the end of the eighth minute of apnoea. In the third dog the heart stopped beating for twenty-six seconds during the fifth minute of apnoea. Then the beating returned, and arterial pressure rose to the normal. During the seventh and eighth minutes the animal took a few very shallow breaths. Then it relapsed into apnoea. The heart beats became progressively weaker until they ceased finally twelve minutes after termination of the pain period. The later portions of the record of this experiment are reproduced in Fig. 8. The analytical data of this and one of the other two fatal experiments are given in Table VI.

TABLE VI.

EXPERIMENTS OF MAY 24, AND JUNE 21. DOGS UNDER MORPHIN SULPHATE (0.015 GM. PER KILO) AND ETHER. (See also Fig. 8.)

	May 24		June 21	
Duration of pain-hyperpnoea . . . . .	25 min.		30 min.	
Death after apnoea lasting . . . . .	12 min. <sup>1</sup>		8 min.	
Blood gases at the beginning . . . . .	18.5 O <sub>2</sub>	42.6 CO <sub>2</sub>	20.3 O <sub>2</sub>	36.4 CO <sub>2</sub>
After 4 minutes of apnoea . . . . .	4.2 O <sub>2</sub>	15.4 CO <sub>2</sub>	5.1 O <sub>2</sub>	18.6 CO <sub>2</sub>
At death . . . . .	0.0 O <sub>2</sub>	31.9 CO <sub>2</sub>	0.0 O <sub>2</sub>	29.6 CO <sub>2</sub>

<sup>1</sup> The animal drew a few weak breaths.

V. THE USUAL FORM OF DEATH IN SHOCK.

In another series of twenty dogs shock was induced by exposure and handling of the abdominal viscera. Most of these animals died because of failure of the circulation instead of failure of respiration. Yet all, or nearly all, would have passed into fatal apnoea before arterial pressure had fallen to the critical point if cessation of breathing had not been prevented by a continual afferent irritation. After the first hour and a half of hyperpnoea induced by insult to the viscera, a fatal apnoea occurred in every experiment in which the stimulation was then interrupted. In these cases heart failure followed the cessation of breathing by only sixty to ninety seconds, and progressed to complete and irre-

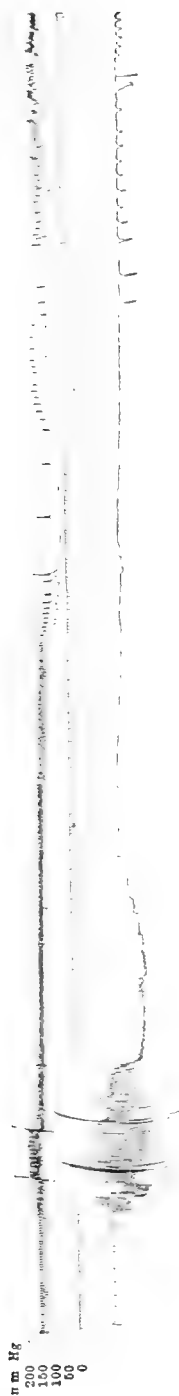

FIGURE 7. — Experiment of May 21, 1909. Methods of recording were the same as in Fig. 1. At the breaks in the curves the record is omitted for ten, ten, two and a half, two, and five minutes respectively. The record shows a preliminary period of normal breathing and pulse. Then pain-hyperpnœa under electrical stimulation of the sciatic nerve for twenty minutes as indicated by omission of time line. Apnœa for six and a half minutes. The irregularities in the pneumograph line were due to trembling. After four and a half minutes of apnœa the heart nearly stopped. It recovered however — probably by escaping from vagus inhibition — and was approaching final failure, when the animal gasped twice. Irregular breathing followed, and finally recovery. For blood gas analyses see Table V. Fig. 7 is about one fourth the original size.



FIGURE 8. — Experiment of May 24, 1909. Methods of recording were the same as in Fig. 1. The animal had been subjected to twenty-five minutes of pain-hyperpnœa, and had then sunk into apnœa. The record of these periods was identical with the corresponding portions of Fig. 7, and are here omitted. The portion reproduced shows the temporary standstill of the heart at the end of the fifth minute of apnœa, the return of the beating, and the final progressive diminution in the amplitude of the pulse ending in death. The pneumograph line shows that the animal drew a few weak inspirations, thus prolonging its life by about four minutes. For blood gas analyses, see Table VI. Fig 8 is about one fourth the original size.

mediable standstill of the heart within thirty seconds more. In a typical case our notes report a vigorous young dog under ether without morphin. The intestines were handled and aerated in a stream of warm moist air for two hours. The arterial pressure was then 110 mm. of Hg, the pulse very small, and the heart rate rapid. The breathing was quick but not very deep. The operator's attention was distracted for not more than two minutes, and when he turned back again to the animal, it was dead. Restorative measures failed to excite the slightest response of respiration or of the heart. The gases of the arterial and venous blood (the latter drawn from the right heart) are shown in Table VII.

TABLE VII.

EXPERIMENT OF MARCH 10, 1908. DOG UNDER ETHER WITHOUT MORPHIN.

Volumes per cent of blood gases	Arterial		Venous	
At the beginning . . . . .	28.9 O <sub>2</sub>	42.6 CO <sub>2</sub>	24.9 O <sub>2</sub>	46.2 CO <sub>2</sub>
Shortly before fatal apnœa . . . . .	28.6 O <sub>2</sub>	26.4 CO <sub>2</sub>	5.8 O <sub>2</sub>	41.7 CO <sub>2</sub>

In order to obtain graphic records of the events above described and to make certain of their cause, this fortuitous experiment was twice intentionally repeated. The results of one of these repetitions are shown in Fig. 9 and Table VIII. Just before death would have occurred, an intravenous injection of 100 c.c. of Ringer's solution saturated with CO<sub>2</sub> was administered; and the animal was allowed to breathe an atmosphere containing a small amount of CO<sub>2</sub>. As the record shows, the respiration was immediately restored, and this improvement was maintained so long as the animal continued to breathe CO<sub>2</sub>. Arterial pressure was also raised by the infusion, but this effect was merely temporary. Later the circulation failed. In another experiment Ringer's solution without CO<sub>2</sub> was injected. Respiration was not thereby noticeably improved, and the animal died in apnœa.

TABLE VIII.

EXPERIMENT OF MAY 21, 1908. DOG UNDER ETHER WITHOUT MORPHIN.

Volumes per cent of blood gases	Arterial		Venous	
At the beginning . . . . .	15.9 O <sub>2</sub>	37.4 CO <sub>2</sub>	15.2 O <sub>2</sub>	39.4 CO <sub>2</sub>
Shortly before fatal apnœa . . . . .	15.8 O <sub>2</sub>	16.1 CO <sub>2</sub>	0.0 O <sub>2</sub>	33.1 CO <sub>2</sub>

The cause and character of the disturbance of the circulation which co-operated with apnœa vera to hasten death in these experiments will be discussed in a later paper. The point to be here emphasized is that *in*

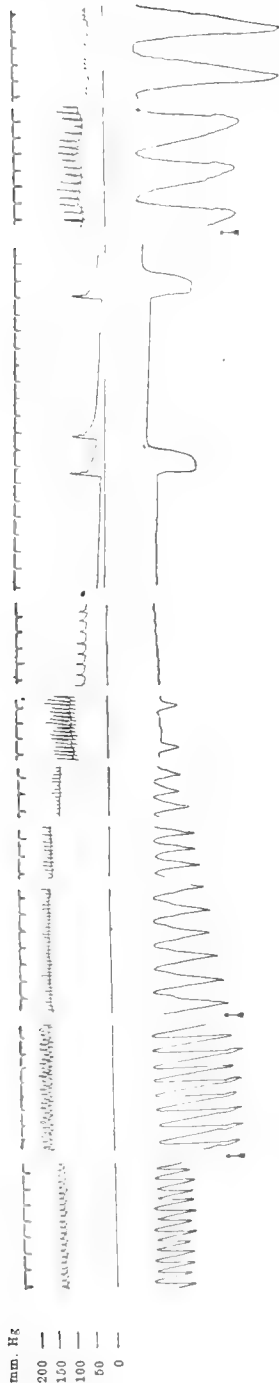

FIGURE 9.—Experiment of May 21, 1908. Time in seconds. Carotid pressure. Respiration recorded by a volumetric spirometer, so that the relative amplitudes of the breaths are shown accurately. At the first arrow the abdomen was opened, and the viscera handled in a stream of warm moist air for an hour and a half. This induced continuous hyperpnœa. At the second arrow the viscera were replaced and the abdomen closed. At each of the next five breaks in the curves the record is omitted for ten seconds. Note the rapid diminution in the amplitude of breathing, resulting in apnœa within one minute. When the animal had sunk to an occasional gasp and heart beat (as shown), 100 c.c. of carbonated Ringer's solution was injected slowly into the femoral vein (at the third arrow). The next section of the curves was recorded one minute later, and the last portion fifteen minutes later, just before final failure of the circulation. For blood gas analyses see Table VIII. Fig. 9 is about three fifths the original size.

*shock fatal a p n œ a vera occurs before failure of the circulation, unless the respiratory centre receives a continual stream of afferent irritations.*

The extensive investigations of Crile have been generally regarded as demonstrating that "an abnormally low blood pressure is the essential phenomenon of surgical shock."<sup>14</sup> The interpretation which we place upon our experiments is mainly based upon the demonstration by Haldane and his co-workers of the conditions normally regulating respiration. Crile could not adopt the acapnia theory because his work on shock was performed prior to the publication of the crucial paper of Haldane and Priestley and before the invention of the term "acapnia" by Mosso. Aside from differences of interpretation, however, our experiments have confirmed the accuracy of Crile's investigations in nearly every respect, and have shown his descriptions of phenomena to be so true to life that we might readily adopt his phraseology to describe our observations.

<sup>14</sup> CRILE: Shock and collapse in Keen's surgery, 1906, i, p. 926.

In discussing failure of respiration in shock Crile says:<sup>15</sup> "In 103 of the experiments in which the exact manner of death was recorded, or in which, in the course of experiments, either the heart or respiration failed first, respiration alone failed in 90, the heart alone in 4, and both simultaneously in 9. In many instances the heart was beating strongly and the blood pressure was fair at the time respiration failed. Artificial respiration was frequently required during the course of the experiments. The greater the extent of the dissection, and especially if dissection had been made in the thorax or abdomen, the more readily respiration became exhausted. In bloodless amputations of the hip joints and other mutilating experiments, respiratory failure occurred first. Almost every injury causing any effect on the circulation causes respiratory changes, usually more striking than the vascular, and in many experiments, notably in the splanchnic area, respirations were more sensitive to irritation than was the circulation. In traumatism of the brain the respirations were strikingly more affected than the circulation, and the immediate cause of sudden death from traumatism of the brain was in almost every instance failure of respiration. . . . In almost every instance of dangerous anaesthesia, the respirations were most affected, and frequently stopped suddenly. . . ."

In a recent paper Malcolm<sup>16</sup> has described the behavior of patients after major surgical operations as he saw it in the London hospitals in the days of the Lister carbolic spray. He says that it was then "a common observation that patients were apt to collapse on being moved from the operating table to bed." He considers that at this time the blood pressure probably fell lower than at any other. It is noteworthy that this was also exactly the time when apnoea vera would occur because of the cessation of afferent irritations.

## VI. FATAL APNŒA IN MAN.

A single case illustrating the results of torture in man will serve to show that the phenomena which we have here attempted to analyze are not mere laboratory products. For the account of this case quoted verbatim below we are indebted to Dr. George G. Graessle of Seymour, Indiana:

<sup>15</sup> CRILE: Surgical shock, 1899, p. 143.

<sup>16</sup> MALCOLM, J. D.: Transactions of the Medical Society of London, 1900, xxxii, p. 289; and Lancet, 1905, i, ii, pp. 573, 618, 737, 922.

"Mr. L. was injured by the explosion of a giant fire-cracker on July 4, 1909, about 9.30 P. M., causing extensive laceration of the left hand and left chest wall over the heart. I saw him a few minutes after the accident and found him suffering intensely, nervous, anxious, but with fair pulse. I gave him  $\frac{1}{4}$  gr. morph. at 9.45, which did not seem to give him relief.

"I will endeavor to answer your questions as asked so as to avoid missing any:—

FIGURE 10.

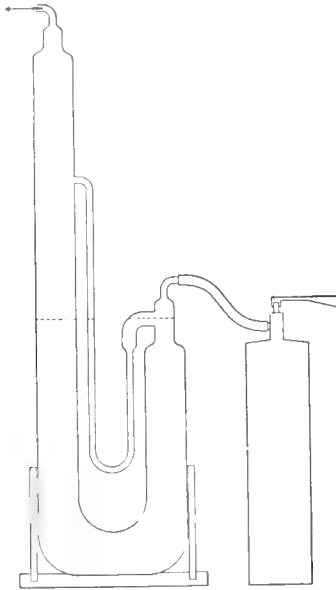
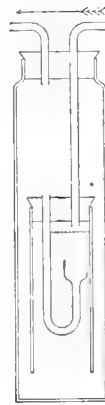

FIGURE 11.



FIGURES 10 AND 11. — *A simple gas meter employed in these experiments.* In supplying oxygen to the lungs by the Volhard method during apnœa, or in administering  $\text{CO}_2$  as a stimulant to respiration, it was found advisable to measure the gases. When the quantities were merely guessed at from the bubbling in a wash-bottle, too little oxygen and too much  $\text{CO}_2$  were sometimes supplied. In Fig. 10 is shown a form of the meter with a stroke of 300 to 400 c.c. which will work at any desired rate up to 20 per minute. It is 50 cm. in height, and the glass tubing of which it is made is 4 cm. in diameter. It is filled with water to the dotted lines. When gas is turned on, the water sinks in the right limb, and rises in the left, until the water in the small tube between the limbs blows out. Then the water falls suddenly in the left and rises in the right limb, so that the small tube is refilled and the gas again trapped. In Fig. 11 is shown another form of the meter, 25 cm. in height, which is convenient for volumes less than 100 c.c. It measures with a stroke sufficiently uniform for the purpose when attached to a Kipp generator of  $\text{CO}_2$ . Its construction requires merely a wide-mouthed bottle, a short piece of wide glass tubing (or a lamp chimney), two rubber stoppers, and some small glass tubing. A large meter of this form (Fig. 11) is easily made from a tall pathological specimen jar.



“(1) The duration and intensity of suffering?”—From time of accident 9.30 to 11.30, time of giving anæsthetic, suffering was intense.

“(2) The vigor of the breathing under pain?”—Breathing was shallow and quick, prolonged expiration. No crying or groaning.

“(3) Loss of blood?”—Not much.

“(4) When and how much morphin was given?”— $\frac{1}{4}$  gr. hypo. about fifteen minutes after accident. No effect.

“(5) Difficulty of inducing anæsthesia?”—Anæsthesia attempted at 11.30, respiration bad, and anæsthetic (ether) withdrawn.

“(6) *Character of decline toward death?*”—*Respiration improved after withdrawal of anæsthetic, remaining fairly regular until 1.20. Then it ceased instantly. Artificial respiration and stimulants did no good. The heart pulsed with fair vigor for a few minutes, but respiration could not be restored. Patient was dead about 1.30.*

“Mr. L. was a man of good habits and perfect physique, age 53 years.”

Surely the death of this man was similar in nearly every detail to the fatal apnœa vera observed in our experiments.

#### CONCLUSIONS.

The hyperpnœa induced by intense afferent irritations involves excessive pulmonary ventilation. The condition of acapnia which results is identical with that produced by forced breathing in men, and by excessive artificial respiration in animals.

When the quantity of CO<sub>2</sub> in the blood has been reduced below the threshold of the respiratory centre and the irritation is considerably diminished, apnœa vera occurs. If the acapnia is intense, apnœa may continue until death results from oxygen starvation of the heart. The fatal process usually occupies eight minutes, but if the arterial blood stream is greatly diminished it may occur in less than two minutes.

During the anoxhæmia of prolonged apnœa, asphyxial acidosis develops. If the acapnia is not intense, these products of incomplete tissue combustion induce isolated gasps followed by Cheyne-Stokes breathing, and prevent immediate death.

After intense bodily suffering failure of respiration is the usual form of death. It is only when the pain is sufficiently continuous to prevent apnœa that the slower process of failure of the circulation develops.

The administration of CO<sub>2</sub> gas in proper dilution during the ap-

nœa after pain-hyperpnœa restores spontaneous breathing. The administration of oxygen prolongs apnœa, but cures the fundamental abnormal conditions, — acidosis and acapnia.

Because of the influence of ether as a "respiratory stimulant" moderate ether anæsthesia tends to prevent apnœa (in dogs) unless neutralized by morphin.

I am indebted to my colleagues, Prof. F. P. Underhill and Dr. M. M. Scarbrough, for valuable assistance and criticism.

NOTE. — Shallow irregular breathing, sighing, Cheyne-Stokes respiration, and muscular trembling were clearly recognized and described as typical phenomena of traumatic shock by the older clinical observers. Cf. FISCHER, H.: Ueber den Shok, in VOLKMANN'S Sammlung Klinischer Vortäge, 1870, No. 10, p. 3; also GROENINGEN, G. H.: Ueber den Shock, 1885, p. 88.

# THE DEPRESSION OF THE AMMONIA-DESTROYING POWER OF THE LIVER AFTER COMPLETE THYROIDECTOMY.

BY A. J. CARLSON AND CLARA JACOBSON.

[From the Hull Physiological Laboratory of the University of Chicago.]

## I. INTRODUCTORY.

THE experiments reported in this paper were undertaken with the view of determining the cause of the increased ammonia content of the blood after thyroid-parathyroidectomy and the relation of this increased ammonia to the tetany symptoms. The literature seems to show that thyroid-parathyroidectomy results in increased ammonia elimination in the urine and an increase in the ammonia in the blood. The relative and absolute increase in the urine ammonia indicates that the increase in the blood is not primarily due to retention owing to impaired kidney activity. There remain three possible causes for this increase in the blood. (1) Defective oxidation and consequent acidosis would lead to this, as it is known that under those conditions ammonia is split off from the proteins to neutralize the organic acids, and this ammonia would be protected from the liver by the acid bodies. (2) It may be due to a too rapid protein destruction and consequent ammonia production, the ammonia production being too rapid to be taken care of by an otherwise normal liver, and hence the increase in the circulating ammonia. That this is the sole or even the important factor seems improbable because of the rapid destruction of ammonia in the normal liver during the digestion and absorption of a protein meal. It would also seem that this factor demands a total nitrogen elimination much greater than has been found after thyroid-parathyroidectomy. (3) The ammonia-destroying power of the liver (and possibly other organs) may be impaired. Either one of these conditions would seem to account for the ammonia increase in the blood after thyroid-parathyroidectomy, but

there appears to be nothing in the literature against the possibility that all three factors are involved.

There is a striking similarity, if not identity, in the tetany symptoms of thyroid-parathyroidectomy, the symptoms of ammonia poisoning, and the symptoms of poisoning in Eck-fistula dogs when fed on meat. In the Eck-fistula animals the symptoms must be primarily due to liver insufficiency (which is equivalent to liver depression) and not to acidosis, except possibly in so far as acidosis may be due directly or indirectly to the liver insufficiency. These facts led us to search for a possible parallel condition of the liver in thyroid-parathyroidectomy.

## II. THE LITERATURE.

Underhill and Saiki,<sup>1</sup> MacCallum and Voegtlin,<sup>2</sup> and Berkeley and Beebe<sup>3</sup> found both a relative and absolute increase in the ammonia in the urine after thyroid-parathyroidectomy in dogs. Coronedi and Luzzatto<sup>4</sup> attributed the tendency to alkaline reaction in dog's urine after complete thyroidectomy to increased ammonia content. This is partly confirmed by Underhill and Saiki. The work of MacCullum and Voegtlin established the further important fact that parathyroidectomy or complete thyroidectomy greatly increases the ammonia content of the blood. Musser and Goodman<sup>5</sup> record great increase in the urinary ammonia in various types of clinical tetany; while the results of Underhill and Saiki seem to indicate a direct relation between the ammonia percentage in the urine and the severity of the experimental tetany. This relationship is also indicated in the clinical cases as recorded by Musser and Goodman. Marfori<sup>6</sup> investigated the effects of intravenous injections of the carbonate, lactate, and tartrate of ammonia in dogs. He found the symptoms more or less varied in sequence and intensity according to the quantity injected and the rate of injection. They were in the main characterized by tremors and twitchings of various muscles, which in some cases developed into a "clonic-tonic" nature, even tetany and opisthotonus being observed; irregular respiration, sometimes deep and labored, at other times shallow and frequent; salivation; vomiting; somnolence, general weakness, and depression. Not all of these symptoms were recorded for any one case, but there was a general similarity in all. One of these experiments might be cited for illustration. Tremors appeared after the injection of 0.0178 gm.  $\text{NH}_3$

per kilo body weight. The time of injection was thirty-two minutes. This indicates that a relatively large quantity of ammonia must be injected, when the injection is gradual, in order to induce tetany symptoms. But this does not indicate the actual percentage of ammonia in the blood at the time of the onset of the tetany symptoms, because of the passage of the ammonia into the lymph and the tissue fluids and the rapid destruction of it in the liver. When injections were stopped, all abnormal symptoms totally disappeared within an hour. This indicates that excess of ammonia in the blood is normally destroyed or eliminated very quickly.

The work of Berkeley and Beebe<sup>3</sup> brings out the same symptoms of ammonia poisoning. Their work shows, further, that intravenous injection of xanthin produces similar tetany symptoms.

The work by Pawlow and his students,<sup>7</sup> by Rothberger and Winterberg,<sup>8</sup> and still later by Hawk,<sup>9</sup> on dogs with Eck-fistula have established a series of data of great importance in this connection. They have shown that such animals can get along tolerably well, especially when allowed little meat in their diet. However, when given or forced to take large quantities of meat, various symptoms of intoxication usually appear. These, as described by Pawlow,<sup>7</sup> point to stimulation or increased excitability of the central nervous system; extreme restlessness, sometimes clonic spasms and tetany being apparent. Or there are somnolence, general feebleness, more or less lack of co-ordination in gait (ataxia), loss of sight, loss of pain sensation and muscle sense (catalepsia), dyspnoea, and salivation. However, these symptoms are not invariable, either in their occurrence or in their course. In some cases the symptoms are very mild, and in a few cases meat feeding is not followed by any perceptible symptoms whatever. A possible collateral circulation was advanced to explain these exceptions, and certain experiments confirmed the supposition to some extent. It was observed that the ammonia excretion was increased absolutely, and particularly in relation to the urea excretion. Carbamates were also found in the urine in these cases. Pawlow, administering carbamates of sodium and calcium intravenously, subcutaneously, and *per os* into animals having the Eck-fistula, obtained symptoms practically identical with those of meat intoxication and concluded that carbamic acid was the primary cause of the symptoms. But, on the basis of later work, Pawlow, Nencki, and Zaleski,<sup>10</sup> and Salaskin and Zaleski<sup>11</sup> concluded that the excess of am-

monia in the blood is primarily, if not entirely, responsible for the intoxication. They found that the ammonia content of the arterial blood in the Eck-fistula dogs showing symptoms of poisoning was increased to approximately the same concentration as that of portal blood during the digestion of a protein meal, while in those dogs exhibiting no intoxication symptoms the ammonia content of the blood was normal. Hawk<sup>9</sup> made the additional observation that in the Eck-fistula dogs that failed to show symptoms on meat diet even though continued for a long time, the addition of Liebig's extract brought them on in a few days, while, on the other hand, Liebig's extract together with a meat-free diet failed to provoke any toxic symptoms. Feeding sodium carbamate as well as its intravenous injections into normal and Eck-fistula animals were productive of no such toxic symptoms as those observed after meat feeding.

From the striking resemblance between the meat-intoxication symptoms in Eck-fistula animals described by Pawlow and the symptoms of ammonia poisoning (Marfori, Berkeley and Beebe), it seems probable that the excess ammonia in circulation is the primary cause of the effects observed in the former. Normal arterial blood of the dog contains from 1.3 to 1.8 mgm.  $\text{NH}_3$  per 100 c.c., and portal blood may contain from 3.5 to 8.5 mgm. depending on the diet; and as only a comparatively small excess of ammonia is necessary to produce toxic effects, it is evident that eliminating the liver from the portal system as in Eck-fistula, or introducing any factor depressing the functional activity of the liver, must result in ammonia intoxication.

The symptoms above described are very similar, if not identical, to those following parathyroidectomy in carnivora. Muscular tremors, tetany, salivation, and dyspnoea are here typical. Hyperexcitability has often been observed; restless walking to and fro was particularly noticeable in some of our foxes. On the other hand, marked depression, weakness, somnolence, were also frequently noted. The depression was sometimes accompanied by muscular tremors. Underhill and Saiki<sup>1</sup> record apparent blindness and deafness in one of their experiments. A certain lack of motor co-ordination is present in a more or less marked degree in nearly all cases; catalepsia has also been observed by us in cats. Respiration may either be deep and labored or shallow and rapid. Furthermore, Munk<sup>12</sup> and Breisacher<sup>13</sup> have observed that the tetany in parathyroidectomized dogs was accelerated and intensified by changing

from a milk to a meat diet, thus increasing the amount of protein and consequently the ammonia in the portal blood. MacCallum and Voegtlin state that of all their parathyroidectomized dogs placed on starvation diet only three gave evidences of tetany. Berkeley and Beebe also conclude that a meat diet accelerates and intensifies the tetany symptoms. On the other hand, Underhill and Saiki make the observation that feeding has no effect on the ammonia excretion, but they base their deduction on results obtained from starvation and milk diet, which may be inadequate to produce an appreciable increase. In our parathyroidectomized cats, in particular, we noted that apparently those animals having good appetites and plenty of milk and meat before them came down more quickly and with more severe symptoms than did those which ate little or nothing following the operation. In the well-fed animals the phase of excitation seemed the more pronounced. In starvation or loss of appetite, depression with dyspnoea, and transient tremors, were most common.

### III. EXPERIMENTAL METHODS.

The excised livers of normal and thyroid-parathyroidectomized cats and foxes were perfused with solutions containing ammonia. The animal under experimentation was bled to death under light ether anaesthesia, the blood defibrinated, 75 c.c. of it added to 225 c.c. of Ringer's solution containing 0.02 gm. ammonium carbonate to 100 c.c. This resulting solution was then used for the perfusing of the liver. Thus we have a solution of very near the same chemical composition as that of the normal blood. The blood serves as oxygen carrier. The proportion of ammonia is approximately that in portal blood at height of digestion, thus excluding the possibility of ammonia intoxication in the liver itself and at the same time introducing sufficient ammonia to show an appreciable change in the final analysis.

At the same time that the preparation of this solution was being attended to, the liver was exposed as quickly as possible, the portal vein ligatured together with the accompanying vessels; hepatic artery, bile duct, etc., as far from the liver as was possible and convenient — usually about 2 cm. — and severed distally from the ligature. The inferior vena cava was ligatured close to its entrance into the liver substance inferiorly and cut below. The liver was then removed by the severing of the vena cava near the heart and the cutting of the diaphragm and the adjoining

membranes, large phrenic and other vessels being ligatured where they seemed likely to cause outflow of the perfusion fluid. Cannulas were inserted into the portal vein for inlet, and inferior vena cava above for outlet. The hepatic veins are so short and branching that the inferior vena cava is much more convenient for this purpose.

The method of perfusion was that introduced in Schröder's original experiments on the excised liver, the solution flowing from a "pressure" bottle through a spiral condenser, the surrounding water in which kept at  $43^{\circ}$  C. so that the perfusion fluid and incidentally the liver was at  $40^{\circ}$  C., or as near normal temperature as possible. A hydrostatic pressure of 50 cm. was just sufficient to cause the solution to flow through the liver in a steady, even stream. Oxygenation was effected in a degree by allowing the solution to flow over the side of the receiving flask and through gauze into the "pressure" bottle, thus exposing as large a surface as possible to the air. The methods of oxygenation by causing oxygen or air to bubble through the solution, or shaking it up with air were not used, because of the possibility of loss of ammonia. The perfusion was carried on for thirty minutes — this time being thought sufficient to give an appreciable change in the ammonia content, and, on the other hand, not long enough for the pathological changes in the liver cells to affect seriously the result of the experiment.

Certain sources of error introduced in this part of the experiment must be taken into account. In the first place, the time in preparation of the liver after the death of the animal is subject to a slight variation. In most cases, however, the liver was removed before the entire cessation of the heart beat, and the inserting of the cannulas required but a short time thereafter. In our method of oxygenation the solution became gradually venous during the perfusion. The ammonia conversion in the liver depends undoubtedly on the oxygen supply to the liver cells. But the degree of oxygenation is, in all probability, not a serious source of error in the present work, as the oxygen supply was practically the same in the normal and the parathyroidectomized series.

The size of the livers was somewhat variable, but to make this error as small as possible, animals of fairly uniform size were used.

The rate of flow was not always perfectly constant, occlusion of parts by coagulation of blood remaining within the liver, air embolism (though guarded against and relatively infrequent) within the liver, being in all probability the cause. In a large series of perfusions, however, these



various sources of error ought to operate approximately equally in the normal and the operated livers and would thus be eliminated in the general average.<sup>1</sup>

Samples (25 c.c.) of the solution before and after the perfusion were analyzed for ammonia by Folin's method, the ammonia content per 100 c.c. recorded, and the percentage of change noted.

Both thyroid and parathyroid glands were completely removed, no attempt being made to remove the parathyroids alone, because of the practical impossibility of entire removal in cats and foxes. Provisionally we ascribe the tetany and allied symptoms to the removal of the parathyroids, without taking any side in the controversy as to the relation between these glands and the thyroids. It appears to be fairly well established, however, that the symptoms of pure thyroid insufficiency are much slower in development than those of parathyroid insufficiency.

In the case of the operated animals the liver perfusion was made at the first appearance of distinct tremors or tetany. None of the animals used were moribund; hence the depression of the liver in these animals cannot be ascribed to a moribund state of the whole animal, a condition that may be produced by many causes besides complete thyroidectomy. One of the operated cats that showed intermittent tremors died in convulsions when being handled preparatory to the bleeding and the liver perfusion, but the preparation of the liver in this case was made just as rapidly as in the rest of the series.

#### IV. RESULTS.

**1. The ammonia content of the blood after complete thyroidectomy.** — A few analyses were carried out on the ammonia content of the blood of

<sup>1</sup> It did not occur to us, until all the experiments were completed, that a simpler and in all probability much more accurate method might have been used, a method that would have eliminated practically all the sources of error in the present series. The method is simply to ligate the renal vessels, draw 25 or 50 c.c. of blood for ammonia analysis, and then inject intravenously a quantity of ammonium carbonate per kilo body weight that will give approximately 6-7 mgm.  $\text{NH}_3$  per 100 c.c. of blood, and thirty minutes after this injection draw a second sample of blood for ammonia analysis. Or, if large dogs are used, the comparisons might be made between blood samples drawn five minutes and thirty minutes after the injection. It is obvious that under such conditions the liver and liver circulation, the temperature and the oxygenation of the blood would be practically normal. But pressure of other work prevents us from repeating our experiments by this method at present.

normal and thyroidectomized cats and foxes. The results are summarized in Table I. These confirm the observations of MacCullum and

TABLE I.

AMMONIA CONTENT IN MG. PER 100 C.C. OF BLOOD OF NORMAL AND THYROID-PARATHYROIDECTOMIZED ANIMALS.

A. CATS.	
Normal.	Parathyroidectomized.
1. . . . . 1.530	1. 2.635 (slight tremors)
2. . . . . 1.445	2. 2.176 (dyspnœa, slight tremors)
3. . . . . 1.900	3. 2.516 (strong tremors)
4. . . . . 1.445	4. 3.230 (violent tetany)
5. . . . . 1.530	5. 2.516 (strong tremors)
.. . . . ....	6. 2.125 (dysp., saliv., mild tremors)
Average . . . . . 1.570	Average . . . . . 2.533
B. FOXES.	
1. . . . . 2.652	1. 4.760 (tremors)
2. . . . . 2.264	2. 2.720 (mild tremors)
.. . . . ....	3. 4.216 (tremors)
.. . . . ....	4. 1.870 (no symptoms) <sup>1</sup>
.. . . . ....	5. 1.768 (no symptoms) <sup>1</sup>
.. . . . ....	6. 2.550 (intermittent tremors)
Average (including 4 and 5 of operated series) . . . . . 2.388	Average (excluding 4 and 5) . . . 3.561
<sup>1</sup> These are animals 14 and 15 of Table III.	

Voegtlin on dogs. Besides actual increase in ammonia in parathyroidectomized animals, there is an apparent relationship between the ammonia content and the severity of the symptoms, but the evidences are

insufficient for a definite conclusion. The ammonia content of blood of foxes is higher both normally and when operated upon than in cats. But more data are required before we can state this as a generic difference.

It will be noted that the  $\text{NH}_3$  percentage of our operated cats and foxes is considerably lower than that found by MacCullum and Voegtlin in dogs.

**2. The ammonia destruction in the perfused liver.** — The results of the experiments on thirteen normal cats and two normal foxes are summarized in Table II. It will be seen that there is considerable individual variation, depending in part on variations in physiological conditions of the liver, but probably in greater part on varying experimental conditions. The lowest percentage of change is 22, the highest 55, with an average of 40. This figure can, of course, not be taken as a measure of the rate of ammonia destruction in the liver *in situ* under normal conditions.

The results of the experiments on the ten parathyroidectomized cats and the three foxes are given in Table III. Again great individual variations are in evidence, the extremes being 5 per cent and 24 per cent ammonia destruction, respectively. The average percentage of ammonia loss in the thirteen operated animals showing tetany symptoms is 14, or 26 per cent less than in the livers of the normal animals. Table III also indicates that the greatest depression was shown by the livers of the animals exhibiting the severest tetany symptoms, but more work is required to establish this point.

The two thyroid-parathyroidectomized foxes that developed no tetany symptoms showed no diminution in the ammonia-destroying power of the liver. This is of great interest in view of the fact already pointed out, that the blood of these two animals showed no increased ammonia content.

We have so far assumed that the disappearance of the ammonia from the perfusion solution is due to its conversion into urea by the liver cells rather than to its removal from the solution through simple absorption by the liver. If this assumption is correct, series of parallel experiments on the rate of urea formation in the livers of normal and parathyroidectomized animals should yield results similar to these on ammonia destruction. There may be, to be sure, some purely mechanical storage of ammonia in the liver cells, but this factor could not account for the

marked difference in the rate of ammonia disappearance in the normal and the operated animals.

TABLE II.

PERCENTAGE OF AMMONIA DESTRUCTION IN THE LIVERS OF NORMAL CATS AND FOXES PERFUSED FOR THIRTY MINUTES WITH 275 C.C. OF BLOOD, AMMONIUM CARBONATE, RINGER'S SOLUTION MIXTURE.

Animal.	Date.	Mgm. of NH <sub>3</sub> per 100 c.c. solution		Per cent change.
		Before perf.	After perf.	
Cat.	1909.			
1	May 1	3.43	1.94	43.4
2	May 5	3.808	1.888	50.4
3	May 10	3.74	2.10	44.0
4	May 20	3.74	1.68	55.0
5	June 15	3.89	2.24	42.4
6	June 16	3.74	2.84	24.0
7	Oct. 12	3.44	1.94	43.5
8	Oct. 13	3.59	2.39	33.0
9	Oct. 18	3.74	2.86	29.0
10	Oct. 19	4.41	3.34	29.2
11	Nov. 1	3.58	2.20	39.0
12	Nov. 12	4.28	3.32	22.0
13	Nov. 26	3.40	1.768	50.0
Fox.				
14	Nov. 28	4.216	2.924	30.6
15	Nov. 28	4.845	2.652	45.2
Average per cent change for cats . . . . .				38.8
Average per cent change for foxes (incl. 14 and 15, Table III) . . . . .				43.9
Average per cent change for both cats and foxes . . . . .				40.0

While our results show that there is a great depression of at least one of the detoxication functions of the liver in those animals that exhibit tetany symptoms after complete thyroidectomy, they do not prove that this is the sole factor in the increased ammonia in the blood and urine.

They do prove, however, that acid intoxication, if a factor at all, is not the only one. There is very little evidence, either direct or indirect, of acid intoxication. MacCallum and Voegtlin detected lactic acid in the blood of one of their tetany dogs. Underhill and Saiki found diacetic

TABLE III.

PERCENTAGE OF AMMONIA DESTRUCTION IN LIVERS OF COMPLETELY THYROIDECTOMIZED CATS AND FOXES PERFUSED FOR THIRTY MINUTES WITH 300 C.C. OF BLOOD, AMMONIUM CARBONATE, RINGER'S SOLUTION MIXTURE.

Animal.	Date of operation.	Date of perf.	Mgm. NH <sub>3</sub> per 100 c.c. solution.		Per cent change.	Remarks.
			Before perf.	After perf.		
Cat.	1909.					
1	May 6	May 8	3.74	3.1	17.0	Violent tetany.
2	May 20	May 24	4.34	4.04	7.0	Violent tetany.
3	May 26	May 29	3.74	2.86	24.0	Tetany not very marked.
4	May 30	June 2	3.44	3.29	5.0	
5	June 3	June 6	3.74	3.14	16.0	Dyspnoea.
6	June 9	June 12	3.89	3.44	11.6	Salivation and had severe tetany spasm during night; very weak.
7	June 15	June 17	4.30	3.74	13.0	
8	Nov. 16	Nov. 17	4.352	4.08	6.2	Strong tremors.
9	Nov. 23	Nov. 25	3.81	3.06	19.6	Violent tetany. Death in convulsive spasm at beginning.
10	Nov. 29	Nov. 30	4.08	3.536	10.8	
Fox.						
11	Nov. 1	Nov. 4	3.96	3.3	16.6	Slight spasms and tremors; depression.
12	Nov. 12	Nov. 15	3.06	2.78	9.1	
13	Nov. 12	Nov. 15	4.8	3.8	20.0	Slight tremors.
14	Nov. 12	Nov. 22	3.128	1.564	50.	No symptoms.
15	Nov. 12	Nov. 22	3.312	1.632	50	No symptoms.
Average per cent change for cats . . . . .						13.02
Average per cent change for foxes (not including those with no symptoms, 14 and 15) . . . . .						15.2
Average per cent change for cats and foxes . . . . .						14.0

acid in the urine of tetany dogs, but no acetone. The failure of alkali administrations in experimental tetany seems also to speak against the acidosis hypothesis, although it must be admitted that this failure is capable of different interpretations. Indeed, one ought to expect some increase in the blood of acid metabolites, in view of the diminished oxidation power of the tissues (Stookey<sup>14</sup>) and the diminished glycolysis (Underhill and Saiki) after complete thyroidectomy. The depression of the liver in tetany as shown by these experiments seems to receive additional support in the observations of Stookey and Gardner<sup>15</sup> that the oxidation powers and the rate of autolysis in the liver are diminished after complete thyroidectomy in dogs and the reverse experiment by Schryver<sup>10</sup> showing augmented autolysis in the liver after thyroid feeding. † The depressions were also noted (by Stookey) in other organs. In fact, the kidneys may, after all, be secondarily responsible for the toxicity of the blood in tetany. Metabolism experiments indicate that there is increased protein destruction in experimental tetany, and, according to Underhill and Saiki, this increased protein destruction is apparently accompanied by diminished volume of urine secretion. The urine is concentrated, but, as the diminution in urine volume does not appear to be due to lack of ingestion of water, this seems to point to kidney depression.

How do our results articulate with the various theories as to the nature of experimental tetany and of parathyroid functions? It seems to us that they neither support nor contradict the *calcium deficiency hypothesis*, because, if the tetany is really accompanied by diminished calcium content of the blood and of the nervous tissues — and in view of the contradictory findings of recent observers (Cooke<sup>17</sup>) this is still an open question — a smaller percentage of ammonia would in all probability suffice to cause tetany on account of the probable increased excitability of the central nervous system under such conditions. Our results give more direct support to the position taken by Beebe, that the tetany is due to deranged protein metabolism, or toxic protein derivatives in the blood and the lymph.

In the hands of most of the workers in this field experimental and clinical tetany is temporarily relieved by administration of parathyroid

† The negative results recorded by WELLS and BENSON (Journal of biological chemistry, 1907, iii, p. 35) on mixing thyroid and liver in vitro indicate that this is a vital reaction.

preparations and by the injection of calcium, magnesium, strontium, and barium salts. The work of Beebe, and of MacCallum and Voegtlin seems to indicate that the active principle in the parathyroid preparations is a nucleo-protein. In our experience the treatment with calcium salts after complete thyroidectomy yields more striking results in dogs than in cats. In the cats we have so far worked on we have failed to prolong life by calcium injections. The symptoms of depression have never been distinctly relieved either in dogs or in cats by the calcium, but tremor or tetany appears to be promptly relieved in dogs. Berkeley and Beebe found that calcium injections similarly check the tetany symptoms following intravenous injection of ammonia and xanthin.

We suspect, however, that both in experimental and clinical tetany many instances of relief of symptoms by salt injections and parathyroid administrations are mere coincidences, because of the tendency to periodicity in the phenomena, — that is, crisis followed by apparently complete recovery, and this again followed by a second and a third crisis, etc., without any therapeutic treatment of the animals. This periodicity is sometimes very striking in parathyroidectomized foxes, but we have frequently observed it in dogs, and less frequently in cats. The following extract from the record of one of our thyroid-parathyroidectomized monkeys may serve to illustrate this point:

*Male monkey, weight 9.3 kgm.* Oct. 12. Complete thyroidectomy, good recovery.

Oct. 13. Normal.

Oct. 14. Normal.

Oct. 15. Spasms of muscles of head, neck, back, and fore limbs; seems otherwise in good condition; eats.

Oct. 16. Normal.

Oct. 17. Tremors and spasms as on the 15th; eats heartily and shows fight.

Oct. 18-30. Normal, with possible slight depression.

Oct. 31. Strong tetany and convulsions.

Nov. 1-4. Normal.

Nov. 5. Strong tetany.

Nov. 6 to date (Jan. 10). Normal, with apparently slight depression (less active).

Now, this subject was given nothing but the ordinary routine diet — bread, vegetables, and fruit. But if we had injected calcium salts or ad-

ministered parathyroid on the days when tetany was in evidence, the results would certainly have appeared very positive. Such results, for example, as are recorded by Ott,<sup>18</sup> namely, the relieving ("temporary cure") of parathyroid tetany in cats by pituitary extracts, adrenalin, and iodothylin, can hardly be anything but instances of such concurrence. In his hands even "pancreas has a quieting effect in seven cases out of ten."

This periodicity is difficult to bring in line with either of the two leading hypotheses of parathyroid function. If there is a progressive loss of calcium by the nervous tissues, how can we account for these recurrences or the return to normal condition of animals destined to die in tetany? On the other hand, if the tetany is primarily due to ammonia and other intermediary protein metabolites, there must be in many animals a periodic variation in the rate of their elimination by the kidneys or in the rate of their destruction in the body by the liver; or periodic variations in the excitability of the central nervous system. The periods of recovery do not seem to be due to a depressed condition of the central nervous system in consequence of previous over-stimulation.

The workers in this field seem to agree on the point that calcium salts and parathyroid nucleo-protein check temporarily the excitation symptoms of parathyroidectomy. On the hypothesis that these symptoms are primarily due to ammonia and other poisonous protein metabolites in the blood, the calcium salts may act by depressing the central nervous system or by augmenting the detoxication processes in the liver. It seems less likely that the calcium salts accelerate the elimination by the kidneys or effect a direct neutralization in the circulating fluids. The active substance of the parathyroids may similarly act in either or all of the above directions; but in view of our results, it seems probable that it acts by accelerating some of the liver processes concerned in protein metabolism, and we would expect that this nucleo-protein will similarly counteract the symptoms produced by intravenous injections of ammonia salts and xanthin. There appears to be no obvious articulation between the calcium deficiency hypothesis and the effects of parathyroid nucleo-protein.

We have already referred to the singular periodicity in the excitation symptoms sometimes met with in complete thyroidectomized animals, a phenomenon that reminds one of certain types of epilepsy. While it is not always in evidence, yet it seems to us that it has as yet not received



sufficient recognition. And this applies also to the *depression symptoms* of parathyroidectomy. Contradictory as it may seem, in our experience the depression may precede, accompany, or follow the excitation phases. Parathyroidectomized cats on daily calcium injection or on starvation may die in gradually augmented depression in five to ten days without at any time exhibiting signs of excitation. This depression is therefore not necessarily a secondary effect or a fatigue from previous over-stimulation. The depression symptoms must be taken into account by every theory of thyroid-parathyroid function. In this connection it may be of interest to note again that Marfori records instances of apparent primary depression in simple ammonia intoxication. It is evident that the symptom complex or the sequence of the symptoms depend in part on the individual condition of the animal.

#### SUMMARY.

1. In completely thyroidectomized cats and foxes that exhibit the typical symptoms of excitation and depression there is an increased percentage of ammonia in the blood as compared with that of blood in the normal animals (cats, 1.57: 2.50; foxes, 2.38: 3.56 per 100 c.c.). In the operated animals (foxes) showing no symptoms, the ammonia content of the blood is normal. In all the specimens so far worked on, the ammonia content of the blood of foxes is markedly higher than that of the cats, but more data are required to determine whether this is a generic difference.

2. The livers of completely thyroidectomized cats and foxes that exhibit typical symptoms of intoxication show a marked depression of the ammonia-destroying power as compared to the liver of normal animals. The livers of operated animals showing no symptoms exhibit no depression of the ammonia-destroying functions. This depression is probably due to the physiological condition of the liver cells rather than to depressor substances in the blood.

3. The increase in the ammonia content of urine and blood after complete thyroidectomy is therefore due, at least in part, to liver depression rather than to acidosis independent of the liver. It is suggested that the depression of the ammonia-destroying functions is probably indicative of liver depression in relation to other protein detoxication processes, in consequence of which, and also owing to the law of mass action, there is

an increased concentration in the blood of other toxic protein metabolites besides ammonia. These substances are probably primarily responsible at least for the excitation symptoms of complete thyroidectomy.

4. Our results indicate the importance of the thyroid and parathyroid glands to some of the physiological processes in the liver. The detoxication functions of the parathyroids are probably indirect ones rather than neutralization processes in the glands themselves or in the circulating fluids.

#### BIBLIOGRAPHY.

- <sup>1</sup> UNDERHILL and SAIKI: *Journal of biological chemistry*, 1908, v, p. 225.
- <sup>2</sup> MACCALLUM and VOEGTLIN: *Journal of experimental medicine*, 1909, xi, p. 118.
- <sup>3</sup> BERKELEY and BEEBE: *Journal of medical research*, 1909, xx, p. 149.
- <sup>4</sup> CORONEDI and LUZZATTO: *Archives italiennes de biologie*, 1907, xlvii, p. 286.
- <sup>5</sup> MUSSER and GOODMAN: *University of Pennsylvania medical bulletin*, 1909, p. 20.
- <sup>6</sup> MARFORI: *Archives für experimentelle Pathologie und Pharmacologie*, 1893, xxxiii, p. 71.
- <sup>7</sup> HAHN, v. MASSEN, NENCKI, and PAWLOW: *Archiv für experimentelle Pathologie und Pharmacologie*, 1892, xxxii, p. 161.
- <sup>8</sup> ROTHBERGER and WINTERBERG: *Zeitschrift für experimentelle Pathologie und Therapie*, 1905, i, p. 318.
- <sup>9</sup> HAWK: *This journal*, 1908, xxi, p. 259.
- <sup>10</sup> PAWLOW, NENCKI, and ZALESKI: *Archiv für experimentelle Pathologie und Pharmacologie*, 1897, xxxvii, p. 26.
- <sup>11</sup> SALASKIN and ZALESKI: *Zeitschrift für physiologische Chemie*, 1900, xxix, p. 517.
- <sup>12</sup> MUNK: *Sitzungsberichte der Berliner Academie*, 1888, I, p. 1059.
- <sup>13</sup> BREISACHER: *Archiv für Physiologie (Suppl.)*, 1890, p. 509.
- <sup>14</sup> STOOKEY: *Proceedings of the Society of Experimental Biology and Medicine*, 1908, v, p. 121.
- <sup>15</sup> STOOKEY and GARDNER: *Ibid.*, v, p. 120.
- <sup>16</sup> SCHRYVER: *Journal of physiology*, 1905, xxxii, p. 159.
- <sup>17</sup> COOKE: *Proceedings of the Society of Experimental Biology and Medicine*, 1909, vii, p. 13.
- <sup>18</sup> OTT: *The parathyroid glandules from a physiological and pathological standpoint*, 1909, pp. 15-18.

## THE ACTION OF THE PROTEINS OF BLOOD UPON THE ISOLATED MAMMALIAN HEART.

BY L. W. GORHAM AND A. W. MORRISON.

[*From the Physiological Laboratory of the Johns Hopkins University.*]

THE experiments described below were undertaken, at the suggestion and under the direction of Professor Howell, to study the effect of perfusing solutions of fibrinogen through the isolated beating mammalian heart.

For purposes of control and comparison the work was extended to include similar experiments with serum albumin, serum globulin, and calcium-free blood plasma. It was hoped that by quantitative examination of the perfused solutions, before and after perfusion, some indication might be obtained as to whether or not these proteins are directly used by the living tissues. The assumption is usually made that the proteins of the blood serve as the source of the protein consumed by the tissues in the processes of repair and growth, but nothing of the nature of direct evidence has been furnished in support of this assumption. The older evidence offered by Kronecker and others for a specific nutritive effect of serum albumin upon the beating heart has not proved satisfactory, owing mainly to the fact that it neglected to take account of the wonderful effect of solutions of inorganic salts alone in sustaining the beat of the heart. More recently the suggestion has been made that the fibrinogen of the blood may constitute the form in which the protein food is conveyed to the tissues. This point of view is implied or stated by Nolf in the development of his theory of coagulation, and it is supported in a way by what is known regarding the origin of this protein. According to a number of observers fibrinogen is formed by the liver, and injury to or removal of this organ is followed by a decrease or disappearance of fibrinogen in the circulating blood. These considerations suggested the desirability of studying quantitatively the effect of supplying an active organ, such as the beating heart, with a solution of

fibrinogen of known concentration. Locke has shown that the isolated beating heart consumes some of the glucose supplied to it in the perfusing solution, and it was thought that in a similar way the action of a fibrinogen solution might be tested. The general method employed in the following experiments was to circulate a small volume of liquid, containing a known amount of fibrinogen or other protein through the coronary system of a heart isolated according to the well-known method of Newell-Martin. By perfusing the same volume of liquid over and over again an opportunity would be given for the heart to act upon the protein, and at the end of the experiment a quantitative estimation of the protein present should indicate whether or not any was absorbed by the heart. Cats were used in all of the experiments, since the heart of this animal bears isolation more easily than that of the dog. The method of isolation was essentially the same as that described in a previous paper from this laboratory,<sup>1</sup> except that the heart was cut free from the lungs and was then removed from the body and suspended in a cylindrical funnel. The outflow from the coronary vessels was received into this funnel and was then returned to the supply vessel by means of a stream of oxygen bubbles according to the method described by Locke and Rosenheim. The tip of the funnel was closed by a cap of paper so that the volume of liquid circulated through the heart was kept within a practically closed system, and loss from evaporation was thereby reduced to a minimum. At the beginning of the experiment the heart, after the completion of the procedure of isolating, was first washed free from the blood contained in its vessels and cavities by irrigation for three quarters of an hour to an hour upon a stock Locke's solution fed under oxygen pressure, the outflow being allowed to waste. After this preliminary irrigation the test solution of fibrinogen or other protein was turned into the coronary vessels of the beating heart. The first 10 or 20 c.c. of the outflow after this change were allowed to waste, and thereafter the test solution was kept circulating through the heart over and over again in an atmosphere of oxygen. The pressure under which this latter solution was fed to the heart was low, about 50 to 55 mm. of mercury. The heart and the circulating solution were kept at a temperature of 34° to 35° C.

The methods used in preparing and analyzing the various solutions of protein were as follows:

<sup>1</sup> HOWELL and DUKE: *This journal*, 1908, xxi, p. 51.

**Fibrinogen.** — To prepare pure solutions of fibrinogen one or more fasting cats were bled into a solution of sodium oxalate so that the concentration of the mixture was 0.1 per cent sodium oxalate. This blood was centrifugalized and the supernatant plasma was siphoned off. The fibrinogen was precipitated by the addition of an equal volume of saturated solution of sodium chloride. After standing for a while this precipitate was separated by centrifugalizing, the liquid was poured or siphoned off, and the precipitate was washed twice with a one half saturated solution of sodium chloride, the tube being placed each time in the centrifuge to enable the wash liquid to be siphoned off readily. The washed precipitate was dissolved in a 2 per cent solution of sodium chloride, filtered and again precipitated by the addition of an equal bulk of saturated solution of sodium chloride and the precipitate again centrifugalized, washed, and dissolved in a 2 per cent solution of sodium chloride, as above. This solution after filtration was precipitated a third time, but the precipitate after washing was finally dissolved in a 0.9 per cent solution of sodium chloride. The solution thus obtained was in some cases again further treated with barium chloride and sodium phosphate<sup>2</sup> to produce a slight precipitate of barium phosphate. The advantage of this procedure is that it seems to remove from the solution all traces of thrombin or prothrombin, so that the clear solution left remains entirely free from clots for an indefinite time, if no thrombin is added to it. Whether or not this wiping out with barium phosphate was used, the solution of fibrinogen before being perfused through the heart was dialyzed in a collodion tube for twenty-four hours in a cool room against a large volume, 2 to 4 litres, of a 0.9 per cent solution of sodium chloride. By this means all traces of oxalate or other foreign substances were removed. The dialyzed solution of fibrinogen was then brought to the same bulk as the plasma from which it was obtained originally, and calcium chloride, potassium chloride, and sodium bicarbonate were added in strength required for a Ringer's mixture (NaCl 0.9 per cent, CaCl<sub>2</sub> 0.026 per cent, KCl 0.03 per cent, HNaCO<sub>3</sub> 0.02 per cent. In some cases dextrose was also added to the amount, 0.1 per cent, called for in a Locke's solution. A portion of the prepared solution, 25 to 50 c.c., was kept for a determination of the amount of fibrinogen present, the remainder of the solution was irrigated through the heart, as described, and at the end of the experiment 25 to 50 c.c. of the perfused liquid were taken

<sup>2</sup> See RETTGER: This journal, 1909, xxiv, p. 406.

for analysis. The method of determining the amount of fibrinogen was by heat coagulation. The solution was made just perceptibly acid with acetic acid and was heated in a water bath to 60° C. for ten minutes. It was then filtered through weighed filter papers which had been heated to constant weight at 115° C. The precipitates thoroughly washed with water, alcohol, and ether were then again heated to constant weight at 115° C., the difference giving the weight of fibrinogen.

In addition to using solutions of fibrinogen prepared as described above, three experiments were made in which the uncoagulated oxalated plasma was circulated through the heart. In these experiments the cat's blood was oxalated to precipitate the calcium, and was then centrifugalized. The clear plasma was siphoned off and was dialyzed in a collodion tube for twenty-four hours against two successive quantities (4 litres) of a Ringer's solution minus calcium. The solution against which the dialysis was made consisted of sodium chloride 0.9 per cent, potassium chloride 0.03 per cent, and sodium bicarbonate 0.02 per cent. By this means the excess of oxalate in the plasma was removed completely and a plasma was obtained containing the normal proteins of the blood. This plasma clotted firmly within two to three minutes upon the addition of calcium chloride, and less rapidly and firmly upon the addition of strontium chloride. Barium and magnesium chloride had no effect in producing a clot. The plasma was circulated through the isolated and washed heart for as much as four hours over and over again without clotting, while the addition of a little calcium chloride to the perfused plasma at the end of the experiment caused clotting within a few minutes. No perceptible amount of calcium or of thrombin, therefore, is given off by the perfused living heart tissue. On this circulation the heart did not beat regularly, owing to the absence of calcium. The ventricles and auricles gave feeble, slow, and irregular contractions throughout most of the perfusion. The calcium-free plasma thus circulated through the heart was examined before and after perfusion for fibrinogen by the method of heat coagulation. The results, described below, did not differ from those obtained from solutions of pure fibrinogen.

**Serum globulin.** — In preparing serum globulin for perfusion cat's blood was allowed to clot and was then centrifugalized. The clear serum was siphoned off and a portion of the paraglobulin was precipitated by saturation with sodium chloride. The precipitate was filtered, washed with a saturated solution of sodium chloride, and then dissolved in water.

This solution was dialyzed for twenty-four hours against 4 litres of a 0.9 per cent solution of sodium chloride. The solution was then diluted with a 0.9 per cent solution of sodium chloride, so as to give a concentration of protein of about 0.15 per cent, and calcium chloride, potassium chloride, and sodium bicarbonate were added in quantities to make a Ringer's mixture of the composition given above.

**Serum albumin.** — Cat's blood was allowed to clot in tubes and was then centrifugalized. The clear serum was siphoned off, and to it was added an equal volume of saturated solution of ammonium sulphate to precipitate completely the serum globulin. After standing for twenty-four hours, this precipitate was filtered off, and in the filtrate the serum albumin was precipitated by the addition of dilute acetic acid (10 per cent). This precipitate was filtered off and was dissolved in water with the addition of a little sodium carbonate (5 per cent). This solution was dialyzed in a collodion tube for twenty-four hours against running water until it failed to give a reaction with a solution of barium chloride. It was then made up to a Ringer's mixture of suitable concentration in protein as in the case of the serum globulin.

The amounts of serum globulin and of serum albumin in the perfused and the control specimens were determined, as in the case of fibrinogen, by heating the solutions, after they had been brought to a very feeble acid reaction, to 75° C. The coagulum was caught on a weighed filter paper, and after washing with water, alcohol, and ether was again heated to constant weight. In regard to this method of determining the amount of protein present it may be said that in some of the experiments (11, 13) double determinations were made both of the perfused and unperfused specimens. These determinations showed a variation ranging from 0.2 to 0.9 mgm., so that variations in the analytical results up to 1 mgm. must be reckoned as coming within the limits of error of the method used.

#### EXPERIMENTS.

Fourteen successful experiments were made in which the procedure as outlined above was carried out. Three of these experiments were made with serum albumin in the perfusing liquid, two with serum globulin, and nine with fibrinogen. The greatest difficulty was met with in the case of the fibrinogen solutions until experience had taught the proper method

of preparing these solutions. Of the nine experiments made with this protein six were performed with solutions of fibrinogen which were perfused through the beating heart in three cases, through a heart kept inhibited by an excess of potassium chloride in one case, and in two cases through hearts supposed to be dead. The three additional experiments were carried out with a calcium-free plasma thoroughly dialyzed to get rid of the excess of oxalate. The perfusing liquid in this series consisted of normal blood plasma minus the calcium, and the plasma before and after the perfusion was examined quantitatively, for fibrinogen. The results obtained from these experiments are summarized in Table I.

The general fact brought out by the table is that when the heart was perfused with solutions containing fibrinogen or serum globulin (euglobulin) a portion of the protein disappears, that is to say, there is a diminution in the concentration in protein of the perfusing liquid. When the perfusing solution consisted of serum albumin, this loss was not observed; there was, on the contrary, an indication of a gain in concentration.

In the case of the fibrinogen solutions the perfused liquid, after being heated to  $60^{\circ}$  to precipitate the fibrinogen, was heated still further and gave always a second small precipitate at  $83^{\circ}$  to  $85^{\circ}$  C. It was thought at first that the amount of fibrinogen which had disappeared might have been converted into this protein coagulating at  $83^{\circ}$  C. Further examination showed, however, that a similar protein is obtained from the cat's heart if, after thorough washing, it is perfused repeatedly with a small bulk of Locke's solution. This protein coagulating at  $83^{\circ}$  C. is evidently washed out of the cat's heart during perfusion. It is interesting to add that perfusion of a rabbit's heart failed to give a similar result, so that the protein in question may be peculiar to the cat's heart.

The following brief descriptions give the necessary details of the experiments listed in the table:

*Experiment 1.* — Cat's heart isolated and perfused first with a Locke's solution. Subsequently the solution of fibrinogen (125 c.c.) made up in a Locke's solution minus the sugar was perfused for one hour and fifteen minutes. The first effect of this solution was to accelerate and then to inhibit the beat, the ventricles stopping entirely while the auricles beat irregularly. Within a few minutes the heart recovered and gave full strong beats during the rest of the perfusion. At the end of one hour and fifteen minutes this solution was turned off and the heart was perfused with the



No. of exp.	Solution perfused.	Condition of heart.	Total volume of circulating liquid.	Wt. of protein in 25 c.c. of control.		Wt. of protein in 25 c.c. of perfused.		Loss in 25 c.c.		Gain in 25 c.c.		Estimated total loss.		Estimated total gain.		Time of perfusion.
				mgm.	?	mgm.	?	mgm.	?	mgm.	?	mgm.	?	mgm.	per cent.	
I	Fibrinogen	Beating well	125	?	?	?	?	?	?	?	?	?	?	?	?	1½
II	Fibrinogen	Beating well	150	13.1	9.6	3.5	..	21.0	26.7	..	..	..	..	..	1½	
III	Fibrinogen	Beating well	125	9.2	5.7	3.5	..	17.5	38.0	..	..	..	..	..	2	
IV	Fibrinogen	Inhibited by potassium	125	6.5	3.5	3.0	..	15.0	46.1	..	..	..	..	..	2½	
V	Fibrinogen	Dead(?)	125	16.5	15.2	1.3	..	6.5	7.8	..	..	..	..	..	3	
VI	Fibrinogen	Dead(?)	150	22.7	19.0	3.7	..	22.2	16.2	..	..	..	..	..	2	
VII	Calcium-free plasma	Occasional beats	125	36.3	30.0	6.3	..	31.5	17.3	..	..	..	..	..	4	
VIII	Calcium-free plasma	Occasional beats	125	25.6	19.5	6.1	..	30.5	23.8	..	..	..	..	..	2½	
IX	Calcium-free plasma	Occasional beats	125	27.2	22.9	4.3	..	21.5	15.8	..	..	..	..	..	2½	
X	Serum globulin	Beat poorly	125	31.1	26.7	4.4	..	22.0	14.1	..	..	..	..	..	2	
XI	Serum globulin	Beat poorly	125	36.6	30.7	5.9	..	29.5	16.1	..	..	..	..	..	3	
XII	Serum albumin	Beat poorly	150	34.5	36.6	..	2.1	..	..	..	..	..	12.6	6.1	1½	
XIII	Serum albumin	Beat well	165	9.1	14.8	..	5.7	..	..	..	..	..	37.6	62.6	2½	
XIV	Serum albumin	Beat well	150	29.2	29.5	..	0.3	..	..	..	..	..	1.8	1.0	2½	

1 50 times.

stock solution of Locke's liquid. The rate of heart beat increased rapidly, and within ten minutes the heart went into fibrillary contractions. The perfused solution of fibrinogen clotted within half an hour after the experiment, owing to faulty preparation, and the analytical results for fibrinogen were therefore untrustworthy.

*Experiment 2.* — Similar to Experiment 1. The fibrinogen solution (150 c.c.) again gave an initial slowing effect upon the rate of heart beat. The perfusion with this solution lasted one hour and fifteen minutes and was followed by perfusion with a stock solution of Locke's liquid. The result of the latter solution was to accelerate the rate and finally to throw the ventricles into fibrillations.

Twenty-five cubic centimetres of the solution before perfusion contained 0.0131 gm. fibrinogen; 25 c.c. of the solution after perfusion contained 0.0096 gm. fibrinogen. The loss of fibrinogen equalled 3.5 mgm. for each 25 c.c. of solution (26 per cent), or 21 mgm. for the entire volume of solution used.

*Experiment 3.* — Similar to Experiment 1. One hundred and twenty-five cubic centimetres of the fibrinogen solution were perfused for two hours. The initial effect of the solution upon the heart was again to slow the rate, but in a few minutes the heart beat regularly and continued to do so throughout the experiment.

Twenty-five cubic centimetres of the solution before perfusion contained 0.0092 gm. fibrinogen; 25 c.c. of the solution after perfusion contained 0.0057 gm. fibrinogen. The loss of fibrinogen equalled 3.5 mgm. for each 25 c.c. of solution (38 per cent), or 17.5 mgm. for the entire solution used.

*Experiment 4.* — Similar to the preceding experiments except that the concentration of potassium chloride in the fibrinogen solution was increased to 0.15 per cent, sufficient to keep the heart in potassium inhibition as long as this liquid was perfused. One hundred and twenty-five c.c. of fibrinogen solution were used, and the perfusion lasted two hours and fifteen minutes.

Twenty-five cubic centimetres of the solution before perfusion contained 0.0065 gm. fibrinogen; 25 c.c. of the solution after perfusion contained 0.0035 gm. fibrinogen, — a loss of fibrinogen, therefore, of 3 mgm. for each 25 c.c. (46 per cent) or of 15 mgm. for the entire solution used.

*Experiment 5.* — In this experiment an effort was made to ascertain whether there would be a disappearance of fibrinogen if the solution was circulated through a dead heart. A cat's heart was isolated and thoroughly washed by perfusion with Locke's solution for one hour. It was then removed from the body and suspended in a stoppered glass vessel for

twenty-four hours, care being taken not to allow air to get into the coronary circulation. The next day the heart was connected with the perfusion apparatus and first washed out carefully with a solution containing sodium chloride 0.9 per cent and potassium chloride 0.025 per cent to remove all calcium from the coronary vessels and heart cavities. The heart was then perfused with a fibrinogen solution, 125 c.c., containing twice (0.05 per cent) the usual amount of potassium chloride. The perfusion was very slow.

Twenty-five cubic centimetres of the solution before perfusion contained 0.0165 gm. fibrinogen; 25 c.c. of the solution after perfusion contained 0.0152 gm. fibrinogen. There was a loss, therefore, of 1.3 mgm. (7.8 per cent) for each 25 c.c., or 6.5 mgm. for the entire solution used.

*Experiment 6.* — Similar to Experiment 5. The perfusion was again very slow, and the solution was forced through under additional pressure — 150 c.c. of the fibrinogen solution were passed through the heart twelve times in two hours.

Twenty-five cubic centimetres of the solution before perfusion contained 0.0227 gm. fibrinogen; 25 c.c. of the solution after perfusion contained 0.0190 gm. fibrinogen. There was a loss of 3.7 mgm. (16.2 per cent) for each 25 c.c., or 22.2 mgm. for the entire solution used.

*Experiment 7.* — In this experiment the heart was perfused with a calcium-free but otherwise normal cat's plasma prepared as described above. The heart was isolated and first washed thoroughly while beating with a Locke's solution. It was then perfused with 1 litre of a solution containing sodium chloride 0.9 per cent, potassium chloride 0.025 per cent, and sodium bicarbonate 0.02 per cent, to remove all calcium. During this perfusion the heart remained quiet in diastole. The calcium free plasma was then perfused for four hours. As this plasma had been dialyzed for twenty-four hours against a liquid containing sodium chloride 0.9 per cent, potassium chloride 0.025 per cent, and sodium bicarbonate 0.02 per cent, it contained these salts presumably in the same concentration. The volume of circulating plasma was 125 c.c.; the outflow was quite free, and the entire solution was passed through the heart more than twenty times. During this perfusion the heart gave feeble, very slow, and irregular beats, owing no doubt to the absence of the calcium. After circulating through the heart the plasma showed no tendency to coagulate on standing for several days. On the addition, however, of a little of a solution of calcium chloride a firm clot formed in a few minutes. The amount of fibrinogen in the plasma before and after perfusion was determined by heating to 60° C. after making the plasma very feebly acid with acetic acid. The heat coagulation was weighed after washing with cold and

hot water, alcohol and ether, upon weighed filter papers, as described above.

Twenty-five cubic centimetres of the plasma before perfusion contained 0.0363 gm. fibrinogen; 25 c.c. of the plasma after perfusion contained 0.0300 gm. fibrinogen. There was a loss of fibrinogen of 6.3 mgm. (17 per cent) for each 25 c.c., or of 31.5 mgm. for the entire solution.

*Experiment 8.* — Similar to the preceding experiment. One hundred and twenty-five cubic centimetres of the calcium-free plasma were circulated for two and a half hours. The liquid showed no signs of clotting until a solution of calcium chloride was added. During the perfusion the auricles gave feeble beats, and the ventricles an occasional feeble contraction.

Twenty-five cubic centimetres of the plasma before perfusion contained 0.0256 gm. fibrinogen; 25 c.c. of the plasma after perfusion contained 0.0195 gm. fibrinogen. There was a loss of fibrinogen of 6.1 mgm. (23 per cent) for each 25 c.c., or 30.5 mgm. for the entire solution used.

*Experiment 9.* — Similar to the two preceding experiments. One hundred and twenty-five cubic centimetres of the calcium-free plasma were perfused for two and a half hours. The heart, as before, gave only feeble and irregular contractions, and the perfused liquid showed no signs of clotting until calcium chloride was added.

Fifty cubic centimetres of the plasma before perfusion contained 0.0545 gm. fibrinogen; 50 c.c. of the plasma after perfusion contained 0.0459 gm. fibrinogen. There was a loss of 8.6 mgm. (15.8 per cent) for each 50 c.c., or 21.5 mgm. for the entire solution used.

*Experiment 10.* — Experiment with serum globulin. The serum globulin was prepared as described above, and 125 c.c. made up in a Locke's solution without sugar were perfused through the heart for two hours. Upon this solution the heart beat rather feebly; the outflow was good. The amount of serum globulin in the liquid before and after perfusion was determined by heat coagulation at 75° C. in the manner described for the experiments with fibrinogen.

Twenty-five cubic centimetres of the solution before perfusion contained 0.0311 gm. serum globulin; 25 c.c. of the solution after perfusion contained 0.0267 gm. serum globulin. There was a loss of globulin of 4.4 mgm. (14 per cent) for each 25 c.c., or 22.0 mgm. for the entire solution used.

*Experiment 11.* — Similar to the preceding experiment. One hundred and twenty-five cubic centimetres of the serum globulin were circulated for three hours. The heart failed to beat within fifteen minutes after this solution was introduced. The outflow, which was free at first, became markedly less.

Twenty-five cubic centimetres of the solution before perfusion contained 0.0366 gm. of serum albumin; 25 c.c. of the solution after perfusion contained 0.0307 gm. of serum albumin. There was a loss of 5.9 mgm. of globulin for each 25 c.c. (16 per cent), or 29.5 mgm. for the entire solution used.

*Experiment 12.* — Experiment with serum albumin. The serum albumin was prepared as described above. One hundred and fifty cubic centimetres of this solution made up in Locke's liquid without dextrose were perfused through the heart during one and a half hours. The flow was scanty under the usual pressure, and it was necessary to increase the pressure.

During the perfusion the auricles beat feebly, but the ventricles were quiet. The 150 c.c. were passed through the heart 13 times. The serum albumin in the liquid before and after perfusion was determined by heat coagulation at 75° C. in a neutral or feebly acid solution.

Twenty-five cubic centimetres of the solution before perfusion contained 0.0345 gm. albumin; 25 c.c. of the solution after perfusion contained 0.0366 gm. albumin. There was a gain therefore of 2.1 mgm. (6 per cent) for each 25 c.c., or 12.6 mgm. for the entire solution.

*Experiment 13.* — Similar to the preceding experiment. In this experiment 165 c.c. of the albumin solution made up in Locke's liquid without dextrose were perfused through the heart for two and a half hours. During this perfusion the outflow was free and the heart gave strong regular beats.

Twenty-five cubic centimetres of the solution before perfusion contained 0.0091 gm. albumin; 25 c.c. of the solution after perfusion contained 0.0148 gm. albumin. There was a gain of 5.7 mgm. (62 per cent) for each 25 c.c., or 37.6 mgm. for the entire solution used.

*Experiment 14.* — Similar to the two preceding experiments. One hundred and fifty cubic centimetres of the albumin solution were perfused through the heart during two and a half hours. The heart beat vigorously throughout the perfusion.

Twenty-five cubic centimetres of the solution before perfusion contained 0.0292 gm. albumin; 25 c.c. of the solution after perfusion contained 0.0295 gm. albumin. There was a gain of 0.3 mgm. (1 per cent) for each 25 c.c. used, or 1.8 mgm. for the entire solution used.

#### SUMMARY AND CONCLUSIONS.

If one attempts to summarize the results of the above experiments, it is evident, in the first place, that the several proteins used in perfusing the heart — namely, fibrinogen, serum globulin, and serum albumin —

have no distinctly favorable action in sustaining the heart beat. In this respect the protein differs from the dextrose, since in the case of the mammalian heart the dextrose added to the Locke's solution exerts a distinctly beneficial influence in maintaining a good beat in the isolated heart. Whether or not the protein constitutes an injurious constituent of a perfusing liquid is not so clear. With the fibrinogen solutions the first effect observed when the solution reached the heart was a temporary inhibition of the beat. This effect was transient. After a few minutes the heart resumed its normal rhythm, and the fibrinogen seemed not to influence this beat either favorably or unfavorably. With the serum albumin also the heart beat well, although the solution contained no glucose, so that the presence of this albumin has certainly no injurious effect. In the two experiments carried out with serum globulin the heart beat very poorly, so that, as far as the evidence goes, this protein appears to affect the beat in an unfavorable way when added to a solution of salts such as compose the ordinary Ringer's mixture.

The analytical results of the experiments indicate, on their face at least, that fibrinogen and serum globulin are used in some way by the heart, while the serum albumin, on the contrary, is not affected. In considering this result one asks, first, whether the diminution in amount of the fibrinogen and the serum globulin in consequence of the circulation through the heart may be explained otherwise than on the assumption of an absorption by the heart tissue. As the apparatus was arranged, no change could take place in the circulating liquid other than a slight concentration from evaporation, except that possibly the perfused liquid may have suffered a dilution, so far as the protein was concerned, by diffusion with the liquids of the heart tissue. The cat's heart weighs about 18 to 20 gm. in moist condition, and at a maximum 80 per cent of its weight is water. If one makes the improbable supposition that the protein used in the circulating liquid could diffuse uniformly through the heart as through a moistened sponge, the result might be equivalent to a dilution of the circulating liquid by an amount equal to the addition of 12 or 14 c.c. of water. This amount of dilution would suffice to explain the diminution in concentration in some of the experiments, but not in all. In the experiments made with the calcium-free plasmas, in which the fibrinogen was presumably under conditions approximately normal, the average disappearance of fibrinogen amounted to 27 mgm. for each perfusion; while the maximum loss that might be attributed to

the dilution caused by diffusion into the heart mass could not amount to more than 13 mgm. Moreover, it is to be remembered that in the exactly similar experiments made with serum albumin, in which the same possibility of dilution was present, the amount of protein showed an increase rather than a decrease.

The proteins in the perfused liquids were determined by heat coagulation, and it might be supposed that in the case of the fibrinogen especially some change of concentration or reaction had so affected the protein as to alter its coagulation temperature. An explanation of this kind is, however, excluded by the fact that the perfused solutions of fibrinogen were always heated to a higher temperature after filtering off the precipitate produced at 60° C. This further heating developed a second small precipitate at 83° to 85° C., but, as already stated, the protein giving this coagulation is always present in solutions which are perfused through the cal's heart. There is no reason to believe that it could represent in any way a transformation of the fibrinogen.

Finally, it has been suggested that the two globulins were held back in the heart tissue by a species of adsorption which did not affect the serum albumin. If such a reaction occurs, we should have to assume that it takes place in the normal blood also, since the fibrinogen in the calcium-free plasma was present in the form in which it exists in the circulating blood. The results of the experiments seem, therefore, to justify the conclusion that there is a difference among the proteins of the blood of such a character that the fibrinogen and the serum globulin (euglobulin) are capable of absorption by the living tissue, while the serum albumin escapes this action. Whether or not this absorption is initially an instance of adsorptive precipitation, it would seem probable that it has a physiological significance, and would indicate that the globulins rather than the albumins constitute the material of the blood from which the tissues draw their supply of protein food. The fact that in the heart kept inhibited by potassium chloride, as well as in the heart which had been excised for twenty-four hours, there was also an absorption of fibrinogen, does not antagonize this conclusion, since we know that in either case the heart could probably have been revived by irrigating it with a proper Locke's mixture. Similar experiments should have been performed, no doubt, upon hearts killed so as to be beyond the possibility of reviving, but it was necessary to bring the experi-

ments, which have been very time-consuming, to a termination. The results obtained are reported because they seem to give a positive indication of a difference between the albumin and the globulin of the blood, which may prove to be significant in the physiological history of these proteins.



# OBSERVATIONS UPON THE BLOOD PRESSURE OF THE SHEEP.

By M. DRESBACH.

[From the Physiological Laboratory, Cornell Medical School, Ithaca, N. Y.]

## INTRODUCTION.

THE first direct measurement of the sheep's blood pressure was that of Stephen Hales:<sup>15</sup> "I took an estimate also of the force of the blood in a fat gelt sheep or wether, by fixing glass tubes to the jugular vein and carotid artery, in the same manner as I had done to the horse in Experiment III. The sheep was three years old, and weighed ninety-one pounds alive. Its pulse beat 65 times in a minute. The blood rose in the tube fixed to the jugular vein  $5 + \frac{1}{2}$  inches and 9 inches when the sheep struggled and strained. In the tube fixed to the carotid artery, it rose 6 feet,  $5 + \frac{1}{2}$  inches."

A hundred years passed before the physical aspects of the circulation were systematically studied by Ludwig,<sup>16</sup> Volkmann, and others. Volkmann<sup>1</sup> compared the mean carotid pressure in seventeen common animals, including the sheep. For four individual sheep, Volkmann's figures are 98, 156, 169, and 206 mm. of Hg respectively. These pressures, apparently obtained by Volkmann between the years 1840 and 1850, have been quoted by nearly all subsequent writers who have had occasion to state the blood pressure of the domestic animals. Thus Wundt,<sup>2</sup> Hermann,<sup>3</sup> Brücke,<sup>4</sup> Smith,<sup>5</sup> Ellenberger,<sup>6</sup> Landois,<sup>7</sup> Luciani,<sup>8</sup> and Howell<sup>9</sup> all quote figures given by Volkmann, while M'Kendrick,<sup>10</sup> Munk,<sup>11</sup> and Stewart<sup>12</sup> give, from unstated sources, results which are probably those of the early workers. Hagemann's<sup>13</sup> work and du Bois-Reymond's<sup>14</sup> edition of Munk's treatise are the most recent texts upon the physiology of the domestic animals. The former does not discuss the comparative blood pressure of animals; the latter gives 170 mm. Hg as the mean blood pressure in the carotid artery of the sheep, but does not state the name of the observer nor the conditions of the experiment.

In 1867 Jacobson<sup>17</sup> measured the venous pressure in the sheep without anaesthesia, in an animal which made no resistance. He found the venous pressure in this case to be 11.4 mm. Hg in the crural vein, 9 mm. in the brachial, 5.2 mm. in the internal facial, and 0.2 mm. in the right jugular vein.\* In 1884 Cohnstein and Zuntz<sup>19</sup> measured the arterial and venous pressures in the foetal sheep, using the umbilical vessels. In foetuses of various ages they found the mean arterial pressure to run from 39.3 to 83.7 mm. Hg, the latter figure being noted in an almost mature foetus. It appears from this work that the arterial pressure increases as the foetus approaches maturity. The venous pressure ranged from 16.4 to 34 mm. Hg, being unusually high because of the absence of respiratory movements.

#### METHODS.

In the work described in the present paper all operations were painless. Cocain, chloroform, and ether were the anaesthetics.

In getting the normal pressure an attempt was made to have the animals in the best possible condition at the time the record was taken. It is to be stated, however, that some of the sheep had been operated upon for other purposes previous to the observations in this work. Thus, the left cerebral motor area had been removed from sheep A, B, E, and J from two to three weeks before the blood pressure was recorded, but there was no noticeable effect from the operation upon the brain. Total thyroidectomy had been performed upon sheep C, D, F, G, and H with a variable effect upon the weight of the animals and their pulse rates, the general condition of the sheep being unaltered. Sheep I and K were full-grown normal specimens used as controls.

Early in the work, it was apparent that two important factors had to be dealt with in determining the *normal* pressure, namely, general anaesthesia and excitement. We succeeded in greatly reducing these sources of disturbance by use of local instead of general anaesthesia, and by careful handling of the animal. For example, some of our subjects were so indifferent to the procedure that they would eat grass while the pressure tracings were being taken. Others were somewhat disturbed by the novelty of their surroundings. In the sheep the heart rate may

\* In this connection it is recalled that Pawlow<sup>18</sup> measured the blood pressure in the dog without anaesthesia in 1878.

be taken as an index to the degree of excitement. Under the conditions of these experiments the rate may vary in any subject from its normal to more than double its normal rate, while the respiration rate may be but little altered. In sheep F and H the heart rate was increased so little that it may be assumed that there was no excitement. These two animals seemed to be normal in every respect. In the control K, operated upon under local anæsthesia, there was considerable nervous disturbance, as was shown by the behavior of the animal before the operation and by the fact that the heart rate had gone up from the normal (46) to 102. That there was no pain connected with the operation was evident from the fact, already mentioned, that the sheep would eat grass at any stage of the work. But there was still the excitement, and, while it may be doubted that this caused any variation of the blood pressure from the normal, it is not possible to claim an absolutely normal condition for this control animal at the time the record was made.

The other control, I, was operated upon under chloroform anæsthesia, and since there was a remarkably fast heart rate throughout this particular experiment, it is not possible to say that we have the normal pressure in this case either. It is probable that in another series of experiments, in which the object will be to study further the effects of anæsthetics upon this animal, additional determinations of the normal pressure will be made.

The blood pressure measurements summarized below were all taken in the carotid artery (usually the left) by means of the mercury or Hürthle manometers, the latter being used most frequently. In addition to recording the heart beat and blood pressure, tracings of the respiratory movements were usually made by means of a stethograph. When the work was done under local anæsthesia, a 1 to 1000 solution of cocain, plus 4 to 6 drops of a 1 to 1000 adrenalin solution, was used. Thirty to forty cubic centimetres of this mixture were injected quite superficially beneath the epidermis before recording was started. Time was allowed for the animal to recover from the excitement consequent to being restrained upon its side during the operation. In some instances the measurements were made with the sheep standing; at other times the animal lay upon the side or back. It was found that a change of posture might cause a maximum variation of 10 mm. Hg.

When the record was made under general anæsthesia, it was done just after surgical anæsthesia was established, except with animal G.

TABLE I.

Animal.	Age.	Mean blood pressure under			Normal heart rate.	Heart rate under			Normal respiration.	Respiration rate under		
		Cocain.	Chloroform.	Ether.		Cocain.	Chloroform.	Ether.		Cocain.	Chloroform.	Ether.
A <sup>1</sup>	3 months	...	...	62	120	...	...	180	30	..	..	48
B <sup>2</sup>	10 months	...	...	114	100	...	...	104	20	..	..	24
C	3 years	114	...	...	102	135	...	...	20	22	..	..
C*	3 years	...	120	...	90	...	120	...	20	..	18	..
D	3 years	100	86	...	68	93	141	...	20	18	30	..
E <sup>3</sup>	...	...	...	...	...	...	...	...	..	..	..	..
F <sup>1</sup>	10 months	112	70	...	94	108	108	...	20	30	54	..
G	6 years	115	125	...	70	120	126	...	18	18	15	..
H	4 years	115	125	150	68	72	156	150	18	24	30	..
I	6 years	...	102	...	80	...	252	...	32	..	30	..
J <sup>1</sup>	2 months	...	60	120	150	...	168	204	25	..	50	..
K	6 years	100	80	70	48	102	168	...	18	20	24	..

<sup>1</sup> Males.<sup>2</sup> Sex not determined.

<sup>3</sup> Eight weeks old lamb. Results not satisfactory. C, pressure recorded under cocain, and (C\*, same sheep) under chloroform, seven weeks later. The venous pressure in the left facial vein, measured under cocain anaesthesia, was 1.2, 5.5, and 12 mm. Hg in sheep F, G, and H respectively.

The Hürthle manometer was used with all except A, B, C, and D.

whose pressure was recorded forty minutes after the anaesthetic was started. In all cases, except J, the normal heart and respiration rate were counted while the animal was standing undisturbed in the pen, for purposes of comparison.

### RESULTS.

The results of twelve experiments are given in Table I. Attention is called to the third, fourth, and fifth columns, which show the very uniform findings under cocain as compared with those under chloroform and ether. Similar comparisons of the heart rate and respiration rate, recorded simultaneously with the blood pressure, are also presented.

### CONCLUSIONS.

1. The experiments described in this paper indicate that in the sheep the mean pressure in the carotid artery is, on the average, about 110 mm. Hg, when measured carefully under local anaesthesia. The figures given in the literature are probably too high, as they were obtained under undesirable conditions of experimentation. This probably accounts for the disparity in the figures quoted.

2. Blood pressure measurements in sheep under general anaesthesia are liable to vary widely, in the same and different individuals, because of (1) the tendency of the sheep to choke with mucus; (2) its susceptibility to chloroform depression, especially.

### BIBLIOGRAPHY.

- <sup>1</sup> VOLKMANN: *Die Haemodynamik*, 1850, p. 177.
- <sup>2</sup> WUNDT: *Physiologie des Menschen*, 1878, p. 316.
- <sup>3</sup> HERMANN: *Handbuch der Physiologie*, 1880, iv, p. 242; *Lehrbuch der Physiologie*, 1905, p. 505.
- <sup>4</sup> BRÜCKE: *Vorlesungen über Physiologie*, 1885, p. 154.
- <sup>5</sup> SMITH, R. MEAD: *Physiology of domestic animals*, 1889.
- <sup>6</sup> ELLENBERGER: *Physiologie der Haussäugetiere*, 1890, i, p. 256.
- <sup>7</sup> LANDOIS: *Textbook of human physiology*, 1900, p. 165.
- <sup>8</sup> LUCIANI: *Physiologie des Menschen*, 1905, i, p. 202.
- <sup>9</sup> HOWELL: *Textbook of physiology*, 1909, p. 481.
- <sup>10</sup> M'KENDRICK: *Textbook of physiology*, 1889, p. 277.

- <sup>11</sup> MUNK: Physiologie des Menschen und der Säugethiere, 1892, p. 60.
- <sup>12</sup> STEWART: Manual of physiology, 1896, p. 84.
- <sup>13</sup> HAGEMANN, O.: Lehrbuch der Physiologie und Anatomie der Haussäugetiere, 1906, ii.
- <sup>14</sup> DU BOIS-REYMOND, R.: Physiologie des Menschen und der Haussäugetiere, 1908, p. 69.
- <sup>15</sup> HALES, STEPHEN: Statical essays containing hæmodynamics, 1733, p. 26.
- <sup>16</sup> LUDWIG: Archiv für Anatomie, Physiologie, und wissenschaftliche Medicin, 1847, pp. 258, 266.
- <sup>17</sup> JACOBSON, HEINRICH: *Ibid.*, 1867, p. 226.
- <sup>18</sup> PAWLOW: Archiv für die gesammte Physiologie, 1878, xvi, p. 266; *Ibid.*, xx, p. 213.
- <sup>19</sup> COHNSTEIN and ZUNIZ: *Ibid.*, 1884, xxxiv, pp. 216, 219.

## THE INFLUENCE OF THE REMOVAL OF FRAGMENTS OF THE INTESTINAL TRACT ON THE CHARACTER OF NITROGEN METABOLISM. — II. THE REMOVAL OF THE SMALL INTESTINES.

BY A. CARREL, G. M. MEYER, AND P. A. LEVENE.

[From the Rockefeller Institute for Medical Research.]

THE majority of physiologists of to-day attribute to the intestinal tract the most important part in the process of protein assimilation and regeneration. It has been shown that proteins belonging by their physical properties to the same class possess a distinct chemical structure when they are derived from animals of different species. This led to the view that the proteins of the food stuffs before being assimilated must be dismembered into primary components. It was further shown that a complete dissolution of protein cannot be brought about by peptic digestion in the stomach. Hence the conclusion was natural that the disintegration of the protein molecule takes place in the intestinal tract. A more detailed analysis of the work which led up to this assumption was given by Levene and Kober in a previous communication.<sup>1</sup> On the other hand, the repeated failures of investigators to detect in the blood any of the products of protein cleavage led them to the view that also reconstruction of the body proteins takes place in the intestinal wall. This hypothesis laid down by the older writer seems continually to find new evidence in its support.

However, the results of the work upon protein assimilation after gastro-enterostomy seemed to have brought some discord into the apparently logical and harmonious line of evidence of the physiologists. There was no reason, according to the generally accepted theory, to expect that the exclusion (though only partial) of the gastric activity would lower the rate of assimilation and increase that of the removal of the nitrogen ingested in the form of protein. From the experiments recorded in a pre-

<sup>1</sup> LEVENE and KOBER: This journal, 1909, xxxii, p. 324.

vious communication by Levin, Manson and Levene, it is obvious that against every expectation such a condition is actually established after gastro-enterostomy. On that basis the authors thought it possible that the process of protein assimilation and retention was accomplished principally through the activity of the stomach and only in minor degree, if at all, through the function of the intestinal tract. In order further to test the correctness of this conclusion, it was planned to follow the process of protein assimilation and retention in animals after the removal of the larger part of the small intestines.

Previous investigations on the influence of the removal of the small intestine are not very numerous, and the results are not very concordant. The literature on the subject up to 1902 is collected in the paper of Erlanger and Hewlett.<sup>2</sup> Thus, Senn<sup>3</sup> on the ground of his experience on dogs was led to the conclusion that the removal of more than one third of the small intestine is fatal. Also Trzebicky<sup>4</sup> found that removal of large sections of ileum is followed by grave consequences and that the resection of one half is fatal. On the other hand, Monari<sup>5</sup> removed successfully seven eighths of the small intestine, the dog remaining in good health. De Toleppi<sup>6</sup> studied the metabolism of the same dog and found it in a general way normal; only the capacity of the animal for fat absorption was lowered. Finally, Erlanger and Hewlett<sup>7</sup> made extensive studies on the metabolism of three dogs with shortened small intestine. But these authors also were interested principally in the process of absorption from the intestinal tract, and in the general condition of nutrition of the animals after the removal of the largest part of the small intestine; they were not interested in the study of any special phase of digestion or assimilation of protein. Of three dogs, two remained in perfectly good health after the operation and only one was in a poor state of nutrition, so that it never reached its normal weight. It died from emaciation. An analysis of their tables showing the nitrogen balance of the first two dogs reveals facts of considerable importance. It shows that both dogs on a nitrogen intake of about 6.5 gm. per day showed a marked

<sup>2</sup> ERLANGER and HEWLETT: This journal, 1902, vi, p. 3.

<sup>3</sup> SENN: Berliner klinische Wochenschrift, 1899, xxxvi, p. 337.

<sup>4</sup> TRZEBICKY: Archiv für klinische Chirurgie, 1894, xlviii, p. 54.

<sup>5</sup> MONARI: Beiträge zur klinischen Chirurgie, 1896, xvi, p. 429.

<sup>6</sup> DE TOLEPPI: Archives italiennes de biologie, 1894, xxi, p. 445.

<sup>7</sup> ERLANGER and HEWLETT: This journal, 1902, vi, p. 1.



retention of nitrogen, thus making suggestive that protein assimilation is not impeded by the removal of the largest part of the intestinal tract. But, as already stated, the authors did not plan their experiments with a view of studying the process of protein assimilation.

**Plan of experiments.** — We originally intended to follow the plan of experimenting that was chosen in the investigation of the metabolism of animals after gastro-enterostomy, but it soon became clear that the nitrogen balance of the animals with shortened intestines was subject to variations from day to day. The dogs, as in the experiments of Erlanger and Hewlett, showed tendency towards diarrhœa, which influenced the rate of protein absorption and with it the nitrogen balance. We therefore decided to continue each experiment three days. The first day the dog received the standard diet; the second, an additional portion of plasmon was added to the standard diet with the first meal. The diet of the third day was the same as on the first. The daily ration of the standard diet was divided into six equal portions, which were given at intervals of two hours. Since the dogs were subject to diarrhœa, it was frequently impossible not to contaminate some portions of the urine with feces. In order to reduce the frequency of these occurrences to a minimum, the dogs were catheterized every two hours between eight A. M. and twelve P. M., and every four hours between twelve P. M. and eight A. M.

**Methods of analysis.** — The methods of analysis were the same as in the work on the effects of gastro-enterostomy. Total nitrogen was estimated by the Kjeldahl-Gunning method, urea by that of Benedict and Gephart, ammonia by the Folin-Schaffer process.

#### EXPERIMENTS.

*Dog I.* — This dog had been kept in the laboratory for nearly a year and served for the experiments recorded in a previous communication.<sup>5</sup> All that time it was maintained in a state of nitrogenous equilibrium without loss of body weight on a daily nitrogen intake of 3.5 gm. The dog was operated on May 7. About 140 cm. of the jejunum and ileum were removed. The recovery was uneventful, and the dog could be placed on the usual diet of plasmon, cracker meal and sugar on the third day after the operation. The diet of the dog previous to the operation consisted of plasmon, 17.5 gm., cracker meal, 100 gm., and 25 gm. of lard.

<sup>5</sup> LEVENE and MEYER: This journal, 1909, xxv, p. 214.

This diet contained 3.5 gm. nitrogen and 700 calories per day. It was the experience of Erlanger and Hewlett that on dogs with shortened intestine fat interfered with the absorption of the protein of the food. In all the dogs deprived of the greatest part of their small intestine which we had occasion to observe, a diet containing a considerable proportion of fat always resulted in a diarrhœa. It was, therefore, concluded to omit fat altogether from their diet. Thus this dog was given the following diet (Standard diet I): plasmon, 13.5 gm.; cracker meal, 130 gm., and sugar 30 gm. Thus this diet contained 3.5 gm. nitrogen and 700 calories. Notwithstanding the absence of fat the absorption of protein was very imperfect, and varied from day to day. The feces were very liquid, though defecations were not frequent. The daily ration was divided into six equal portions, which were given in two-hour intervals from eight A. M. to six P. M. (Tables I-IX).

## EXPERIMENT I.

	First day, gm. N.	Second day, gm. N.	Third day, gm. N.
Intake . . . . .	3.500	4.500	3.500
Output in feces . . . . .	2.329	3.079	1.983
Absorbed . . . . .	$\frac{1.171}{3.500} = 33.46\%$	$\frac{1.421}{4.500} = 31.4\%$	$\frac{1.517}{3.500} = 43.34\%$
Output in urine . . . . .	1.554	1.616	2.051
Balance . . . . .	-0.383	-0.195	-0.534
Absorbed in excess over the first day	$(1.421 - 1.171) = 0.250$		
Elim'd in urine in excess over the first day	$(1.615 - 1.554) = 0.061$		
Balance between first and second day	+ 0.189		
Absorbed in excess over the first day . . . . .	$(1.517 - 1.171) = 0.346$		
Eliminated in urine in excess over the first day . . . . .	$(2.051 - 1.554) = 0.497$		
Balance between first and third day . . . . .	-0.151		

## EXPERIMENT II.

	First day, gm. N.	Second day, gm. N.	Third day, gm. N.
Intake . . . . .	3.500	5.500	3.500
Output in feces . . . . .	2.825	2.456	2.087
Absorbed . . . . .	$\frac{0.675}{3.500} = 19.3\%$	$\frac{3.044}{5.500} = 55.18\%$	$\frac{1.413}{3.500} = 40.37\%$
Output in urine . . . . .	2.213	2.235	2.420
Balance . . . . .	-1.538	+0.809	-1.017
Absorbed in excess over the first day . . . . .	$(3.265 - 0.678) = 2.590$		
Elim'd in urine in excess over the first day	$(2.456 - 2.213) = 0.243$		
Balance between first and second day . . . . .	+2.347		
Absorbed in excess over the first day . . . . .	$(1.413 - 0.675) = 0.738$		
Eliminated in urine in excess over the first day . . . . .	$(2.087 - 2.213) = 0.126$		
Balance between first and third day . . . . .	+0.864		

EXPERIMENT III.

	First day, gm. N.	Second day, gm. N.	Third day, gm. N.
Intake . . . . .	3.500	5.500	3.500
Output in feces	1.912	2.130	1.940
Absorbed . . . . .	1.588 = 45.37%	3.370 = 61.27%	1.560 = 44.6%
Output in urine . . . . .	2.010	2.803	1.640
Balance . . . . .	-0.422	+0.567	-0.080

Absorbed in excess over the first day (3.370 - 1.588) = 1.782  
 Elim'd in urine in excess over the first day (2.803 - 2.010) = 0.793  
 Balance between first and second day . . . . . +0.989  
 Absorbed in excess over the first day . . . . . (1.500 - 1.588) = -0.028  
 Elim'd in urine in excess over the first day . . . . . (1.640 - 2.000) = -0.370  
 Balance between first and third day . . . . . -0.342

It is seen from the records that the absorption of food after the removal of a large part of the small intestine is imperfect and irregular. Thus, while in normal dogs the value of protein absorption is about 95 per cent of the intake, the absorption in the operated dog under our observation fell once to 19 per cent, and on several occasions was about 30 per cent of the intake. Furthermore, the rate of absorption does not always follow the changes in intake. In order to follow the rate of assimilation after the removal of the greatest part of the intestine it is therefore necessary to take into consideration, not the nitrogen intake, but the value of the nitrogen absorbed from the gastro-intestinal tract. With this as a basis of calculation, it appears that in the second experiment there were assimilated 96 per cent of the nitrogen absorbed during the second and third days in excess over that of the first day. In the third experiment the assimilation was 75 per cent of the excess absorption. This rate of assimilation is considerably higher than the rate observed on animals with gastro-enterostomy and even higher than in normal animals.

On the basis of this evidence it seems suggestive that, after removal of a large part of the small intestine, the capacity of the organism for storing up and assimilating protein at the least remains unaltered. In order to obtain more decisive evidence in support of this view, an experiment of longer duration was performed. The animal was placed four days on a diet containing 5.16 gm. nitrogen; this was followed by a period of four days, during which the food contained 10.25 gm. of nitrogen; and finally, during the four days following the second period, the nitrogen intake was again reduced.

The nitrogen balance was compared between the last four days of the first period and between the second and the third periods. The details of the experiment follow:

*Experiment IV.* — Towards the end of the previously recorded experiments on this operated animal, it refused to take the daily ration with the usual regularity. The usual standard diet was therefore changed to one of beef. A supply of lean beef sufficient to last through the experiment was freed as much as possible from fat and connective tissue, chopped up in a chopping machine and placed in cold storage. The daily ration was divided into six equal portions in the manner of the previous experiments. The animal was catheterized every twenty-four hours. The following table shows the daily intake and output (feces and urine) of nitrogen. The analysis of the table shows that during the four days of the higher nitrogen intake the animal retained ( $-1.37 + 7.12$ ) 8.49 gm. of nitrogen as compared with the four days preceding them. The four days following the period of the high intake the animal remained in a condition of equilibrium. Analysis of the balance from day to day shows that the daily losses of nitrogen in the preliminary period and the gains of the second period took place at a descending rate. Also in the third period on the second, third, and fourth day there is noted a gradually declining loss. Thus, the process of protein retention on the animal deprived of the larger part of its intestine followed the laws established on the ground of observations on normal animals.

*Dog I.* EXPERIMENT IV.

Days.	Standard diet, total gm. N.	St'd diet and plasmon, total gm. N.	Standard diet, total gm. N.
I . . . . .	5.60	7.72	3.95
II . . . . .	5.46	8.68	5.70
III . . . . .	5.46	8.26	5.32
IV . . . . .	5.33	9.18	5.33
Total output . . . . .	21.85	33.84	20.30
Total intake . . . . .	20.48	40.96	20.48
Balance . . . . .	-1.37	+7.12	+0.18

*Dog II.* — Dog of 13.5 kg. weight was operated on October 18, 1909. 2.125 metres of intestine weighing 3.5 kg. were removed. The recovery was uneventful. Weight of dog after recovery was 10.82 kg.

On the ground of previous experience that the operated animal utilized

about 50 per cent of the ingested foodstuff, the standard diet of this animal was calculated to contain a quantity of material equal to twice the requirement of a normal animal of the same weight. Furthermore, since the first dog refused after a time to take the food composed of plasmon and cracker meal, the diet in the present experiments was made up of beef, cracker meal and plasmon. In every other detail the plan of the previous experiments was followed.

The composition of the standard diet II was as follows:

	Gm.	N. in gm.	Cal.
Beef . . . . .	150.0	5.41	125
Cracker meal . . . . .	75.0	1.12	300
Plasmon . . . . .	17.5	2.00	70
Salt . . . . .	2.0		
		<u>8.53</u>	<u>495</u> •

On the day with additional protein the diet contained 35 gm. of plasmon (4 gm. N.) in excess over the normal dog. Two experiments were performed, and the results are as follows (see Tables X, XI, XII, and XIII):

	EXPERIMENT I.		EXPERIMENT II.	
	First day, gm. N.	Second day, gm. N.	First day, gm. N.	Second day, gm. N.
Intake . . . . .	8.53	12.53	8.53	12.53
Output in feces . . . . .	2.72	3.35	0.86	2.69
Absorbed . . . . .	<u>5.82 = 68.1%</u>	<u>9.18 = 73.3%</u>	<u>7.68 = 90.1%</u>	<u>9.84</u>
Output in urine . . . . .	5.15	7.00	5.66	7.31
Balance . . . . .	+0.67	+2.18	+2.02	2.53
Absorbed in ex's over the first day (9.18 - 5.82) . . . . .	= 3.36		(9.84 - 7.68) = 2.16	
Eliminated in urine in excess over the first day . . . . .	(7.00 - 5.15) . . . . .		(7.31 - 5.66) = 1.65	
Balance between first and second day. . . . .	+ 1.51		+ 0.51	

Thus also in this animal there is noted a marked tendency towards protein retention. True, the retention did not reach the same degree as in the first animal. This was due in a great measure to the fact that the animal was receiving continually a diet containing a nitrogen value exceeding the normal requirements of the animal.

In order to obtain more decisive figures in support of the conclusions reached on the basis of the results just recorded, another experiment of twelve days' duration was undertaken. During the first four days the animal received the standard diet; during the following four days the animal received daily 35 gm. of plasmon (4 gm. N) in addition to the

standard diet, and finally, in conclusion, the animal again was placed for four days on the standard diet. The nitrogen balance was as follows:

Days.	Standard diet.		St'd diet + plasmon.		Standard diet.*	
	Total gm. N.	Wt. of dog kg.	Total gm. N.	Wt. of dog kg.	Total gm. N.	Wt. of dog kg.
1	4.90	11.080	8.90 <sup>1</sup>	11.060	7.80	11.080
2	6.27	11.070	8.63	11.060	4.72 <sup>1</sup>	11.120
3	7.30	10.980	6.24	11.100	5.75 <sup>1</sup>	11.100
4	5.93	11.020	7.35	11.060	8.00	11.100
Feces, scurf, etc.	0.97	....	2.55	....	1.96	....
Total output . . .	25.37		33.67		28.23	
Total intake . . .	<u>34.00</u>		<u>50.00</u>		<u>34.00</u>	
Balance . . .	+8.63 gm. N.		+16.33 gm. N.		5.77 gm. N.	

<sup>1</sup> Urine uncontaminated with feces.

Thus it is evident that also in the second animal the removal of the largest portion of the small intestine did not in any way affect the capacity of the organism to assimilate and to store up foreign protein of the food.

A comparison of the nitrogen balance of these two animals with the balance of the animals after gastro-enterostomy placed under the same conditions of diet reveals striking differences. In the animal with gastro-enterostomy the power of protein retention is minimal, while it is practically normal in the animal with shortened intestine.

On the other hand, the degree of utilization of ingested aminoacids is reversed in the animals of the two groups. The difference is most obvious in the experiments with feeding on leucin.

#### LEUCIN EXPERIMENTS.

When leucin was added to the food of a normal animal, about 53 per cent of the excessive nitrogen intake was removed in course of the first twenty-four hours, and the remaining portion in course of the following

day. In a similar experiment on an animal with gastro-enterostomy all the excessive nitrogen intake was removed during the first day of the intake.

Two experiments were performed on the second animal with shortened intestinal tract. The diet of the dog was the same as in the previous experiments, excepting for the addition of 50 gm. sugar. The animal therefore received on this diet (standard diet III) 8.54 gm. nitrogen with 705 calories.

The animal received 18.7 gm. of leucin equivalent to 2 gm. of nitrogen in addition to the usual food. The leucin was added to the first meal. In the first experiment (Tables XIV, XV, and XVI), neither on the day of the leucin intake nor on the following day was the nitrogen output increased over the day of the standard diet. Thus apparently all the leucin passed the digestive tract without being absorbed. In the second experiment the dog received the same quantity of leucin in the same manner as in the first experiment. During the twenty-four hours following the leucin intake there was noted an increased nitrogen output in the urine equivalent to 38.2 per cent of the leucin intake. No increase was noted on the day following.

EXPERIMENT II.

	St'd diet.	St'd diet and l. leucin.	St'd diet.
Intake . . . . . gm. N.	8.530	10.530	8.530
Output: urine . . . . . "	5.535	6.300	5.650
Output: feces . . . . . "	1.210	1.170	2.000
Total . . . . . "	6.745	7.470	7.650
Absorption . . . . . "	7.320	9.360	6.530
Balance . . . . . "	+1.795	+3.060	+0.880

It is obvious from these experiments that in animals with shortened small intestines the absorption of leucin is depressed in a higher degree than that of the more complex protein fragments. On the other hand, the condition is reversed in dogs with gastro-enterostomy.

CONCLUSIONS.

1. After the removal of the larger part of the small intestine the absorption of the ingested protein is diminished.
2. The absorption of leucin is reduced.

3. The rate of assimilation and of retention of the absorbed protein follows the same course as in normal animals.

4. Comparison of these results with those obtained on animals after gastro-enterostomy makes it suggestive that the stomach and not the intestines is the organ principally concerned in the function of protein assimilation.



TABLES I-III.

TABLE I. STANDARD DIET.

Periods.	Total nitrogen grams.	Urea nitrogen.		Ammonia nitrogen.		Undetermined nitrogen.	
		Grams.	Per cent of total nitrogen.	Grams.	Per cent of total nitrogen.	Grams.	Per cent of total nitrogen.
8-12	0.176	0.127	72.2	0.025	14.2	0.024	13.6
12-4	0.294	0.221	75.4	0.045	15.4	0.028	9.6
4-8	0.322	0.243	75.9	0.051	15.9	0.028	8.7
8-12	0.280	0.190	67.9	0.062	22.1	0.028	10.0
12-4	0.266	0.168	63.2	0.077	28.9	0.021	7.9
4-8	0.216	0.089	41.2	0.086	39.8	0.041	19.0

TABLE II. STANDARD DIET AND PLASMON.

8-12	0.193	0.092	47.7	0.065	33.7	0.036	18.6
12-4	0.319	0.251	78.6	0.047	14.7	0.021	6.6
4-8	0.280	0.222	79.2	0.033	11.8	0.025	8.9
8-12	0.245	0.182	74.3	0.035	14.3	0.028	11.4
12-4	0.333	0.261	78.4	0.036	10.8	0.036	10.8
4-8	0.245	0.167	68.2	0.043	17.5	0.035	14.3

TABLE III. STANDARD DIET.

8-12	0.273	0.223	81.7	0.012	4.4	0.038	13.8
12-4	0.385	0.337	87.5	0.013	3.4	0.035	9.1
4-8	0.392	0.305	77.9	0.052	13.2	0.035	8.9
8-12	0.357	0.268	75.1	0.068	19.0	0.021	5.9
12-4	0.350	0.269	76.8	0.039	11.2	0.042	12.0
4-8	0.294	0.209	71.0	0.055	18.7	0.030	10.2

TABLES IV-VI.

TABLE IV. STANDARD DIET.							
Periods.	Total nitrogen grams.	Urea nitrogen.		Ammonia nitrogen.		Undetermined nitrogen.	
		Grams.	Per cent of total nitrogen.	Grams.	Per cent of total nitrogen.	Grams.	Per cent of total nitrogen.
8-12	0.291	0.220	75.6	0.021	7.2	0.050	17.2
12-4	0.371	0.328	88.4	0.016	4.3	0.027	7.3
4-8	0.473	0.408	86.3	0.029	6.1	0.036	7.6
8-12	0.350	0.294	84.0	0.035	10.	0.021	6.0
12 4	0.378	0.261	69.1	0.075	19.8	0.042	11.1
4 8	0.350	0.210	60.0	0.105	30.0	0.035	10.0

TABLE V. STANDARD DIET AND PLASMON.							
8-12	0.298	0.199	66.8	0.067	22.4	0.032	10.7
12-4	0.638	0.533	83.5	0.055	8.6	0.050	7.8
4-8	0.613	0.504	82.2	0.071	11.5	0.038	6.2
8-12	0.298	0.204	68.5	0.051	17.1	0.043	14.4
12 4	0.294	0.206	70.1	0.046	15.1	0.042	14.3
4 8	0.315	0.203	64.5	0.077	23.4	0.035	11.1

TABLE VI. STANDARD DIET.							
8-12	0.235	0.150	63.8	0.053	22.5	0.032	13.6
12 4	0.357	0.291	81.5	0.024	6.7	0.042	11.8
4-8	0.494	0.380	77.0	0.075	15.2	0.039	7.8
8-12	0.315	0.234	74.3	0.053	16.8	0.028	8.9
12 4	0.336	0.236	70.3	0.086	25.6	0.014	4.1
4 8	0.350	0.215	61.4	0.100	28.6	0.035	10.0

TABLES VII-IX.

TABLE VII. STANDARD DIET.

Periods.	Total nitrogen grams.	Urea nitrogen.		Ammonia nitrogen.		Undetermined nitrogen.	
		Grams.	Per cent of total nitrogen.	Grams.	Per cent of total nitrogen.	Grams.	Per cent of total nitrogen.
8-12	0.245	0.140	57.1	0.056	22.9	0.049	20.0
12-4	0.367	0.294	80.1	0.049	13.4	0.024	6.5
4-8	0.453	0.361	79.7	0.043	9.5	0.049	10.8
8-12	0.317	0.250	78.9	0.037	11.6	0.030	9.5
12-4	0.367	0.237	64.6	0.071	19.3	0.059	16.1
4-8	0.261	0.161	61.7	0.074	28.4	0.026	9.9

TABLE VIII. STANDARD DIET AND PLASMON.

8-12	0.398	0.290	72.9	0.028	7.0	0.080	20.1
12-4	0.584	0.514	88.0	0.011	1.9	0.059	10.1
4-8	0.710	0.323	89.2	0.023	3.2	0.054	7.6
8-12	0.420	0.317	75.5	0.033	7.9	0.070	16.6
12-4	0.394	0.293	74.4	0.051	12.9	0.050	12.7
4-8	0.297	0.169	56.9	0.076	25.6	0.052	17.5

TABLE IX. STANDARD DIET.

8-12	0.161	0.105	65.2	0.035	21.8	0.021	13.0
12-4	0.165	0.140	84.9	0.007	4.2	0.018	10.9
4-8	0.414	0.202	73.0	0.090	21.7	0.022	5.3
8-12	0.326	0.198	60.8	0.090	27.6	0.038	11.6
12-4	0.308	0.197	64.0	0.069	22.4	0.042	13.6
4-8	0.266	0.175	65.8	0.071	26.7	0.020	7.5

TABLES X-XII.

Periods.	Total nitrogen grams.	Urea nitrogen.		Ammonia nitrogen.		Undetermined nitrogen.	
		Grams.	Per cent of total nitrogen.	Grams.	Per cent of total nitrogen.	Grams.	Per cent of total nitrogen.
8-12	0.855	0.772	90.4	0.028	3.3	0.005	6.3
12-4	1.065	0.949	89.1	0.051	4.7	0.065	6.1
4-8	1.049	0.923	88.0	0.054	5.1	0.072	6.9
8-12	0.862	0.700	81.2	0.061	7.1	0.101	11.7
12-4	0.585	0.485	82.9	0.050	8.5	0.050	8.5
4-8	0.735	0.615	83.7	0.055	7.5	0.065	8.8

TABLE XI. STANDARD DIET AND PLASMON.

8-12	1.080	0.986	91.2	0.020	1.9	0.074	6.9
12-4	1.756	1.653	94.2	0.038	2.1	0.065	3.7
4-8	1.435	1.290	89.9	0.070	4.9	0.075	5.2
8-12	1.333	1.142	85.7	0.107	8.0	0.084	6.3
12-4	0.665	0.558	84.0	0.042	6.3	0.065	9.7
4-8	0.735	0.636	86.5	0.049	6.7	0.050	6.8

TABLE XII. STANDARD DIET.

8-12	0.820	0.703	85.8	0.022	2.6	0.095	12.6
12-4	1.035	0.879	84.9	0.046	4.4	0.110	10.7
4-8	1.240	1.080	87.1	0.060	4.8	0.100	8.1
8-12	0.890	0.771	86.6	0.084	9.4	0.035	3.9
12-4	0.860	0.668	77.7	0.082	9.5	0.110	12.8
4-8	0.815	0.660	80.9	0.055	6.7	0.100	12.4

TABLE XIII-XV.

TABLE XIII. STANDARD DIET AND PLASMON.

Periods.	Total nitrogen grams.	Urea nitrogen.		Ammonia nitrogen.		Undetermined nitrogen.	
		Grams.	Per cent. of total nitrogen.	Grams.	Per cent. of total nitrogen.	Grams.	Per cent. of total nitrogen.
8-12	1.093	0.930	85.2	0.005	0.5	0.150	14.3
12-4	1.700	1.645	96.8	0.025	1.5	0.030	1.7
4-8	1.645	1.527	92.8	0.098	5.9	0.020	1.3
8-12	1.270	1.076	84.8	0.144	11.3	0.050	3.9
12-4	0.860	0.683	79.4	0.092	10.7	0.085	9.9
4-8	0.740	0.584	79.0	0.076	10.3	0.080	10.8

TABLE XIV. STANDARD DIET.

8-12	1.150	1.060	92.2	0.015	1.3	0.075	6.5
12-4	1.925	1.815	94.3	0.075	3.9	0.035	1.8
4-8	1.750	1.533	87.7	0.067	3.7	0.150	8.6
8-12	1.490	1.291	86.7	0.131	8.8	0.068	4.5
12-4	1.045	0.916	87.7	0.074	7.1	0.055	5.2
4-8	0.970	0.905	93.3	0.020	2.1	0.045	4.6

TABLE XV. STANDARD DIET AND L. LEUCIN.

8-12	0.950	0.865	91.0	0.010	1.1	0.075	7.9
12-4	1.587	1.343	84.7	0.075	4.7	0.169	10.6
4-8	2.000	1.813	90.6	0.092	4.6	0.095	4.8
8-12	1.375	1.206	87.8	0.064	7.6	0.105	4.6
12-4	1.390	1.211	87.1	0.094	6.8	0.085	6.1
4-8	1.055	0.945	89.6	0.080	7.6	0.030	2.8

TABLE XVI.

TABLE XVI. STANDARD DIET.							
Periods.	Total nitrogen grams.	Urea nitrogen.		Ammonia nitrogen.		Undetermined nitrogen.	
		Grams.	Per cent of total nitrogen.	Grams.	Per cent of total nitrogen.	Grams.	Per cent of total nitrogen.
8-12	1.095	0.998	91.1	0.017	1.6	0.080	7.3
12-4	1.475	1.207	81.9	0.075	5.0	0.193	13.1
4-8	1.425	1.170	82.2	0.080	5.6	0.175	12.2
8-12	4.500	4.025	89.4	0.175	3.9	0.300	6.7
12-4							
4-8							

No. of table.	Diet.	Total nitrogen grams.	Urea nitrogen.		Ammonia nitrogen.		Undetermined nitrogen.	
			Grams.	Per cent of total nitrogen.	Grams.	Per cent of total nitrogen.	Grams.	Per cent of total nitrogen.
I.	St'd diet I (p. 4)	1.554	1.038	66.9	0.346	22.2	0.170	10.9
II.	St'd diet I + plasmon	1.615	1.175	72.8	0.259	16.0	0.181	11.2
III.	St'd diet I	2.051	1.612	78.6	0.239	11.6	0.201	9.8
IV.	St'd diet I	2.213	1.721	77.8	0.281	12.7	0.211	9.5
V.	St'd diet I + plasmon	2.456	1.849	75.3	0.367	14.9	0.240	9.8
VI.	St'd diet I	2.087	1.506	72.2	0.391	18.7	0.190	9.1
VII.	St'd diet I.	2.010	1.443	71.8	0.330	16.4	0.237	11.8
VIII.	St'd diet I + plasmon	2.803	2.216	79.1	0.222	7.9	0.365	13.0
IX.	St'd diet I	1.640	1.017	62.0	0.362	22.1	0.261	15.9
X.	St'd diet II (p. 9)	5.151	4.444	86.3	0.299	5.8	0.408	7.9
XI.	St'd diet II + plasmon	7.004	6.265	89.5	0.326	4.7	0.413	5.7
XII.	St'd diet II	5.660	4.761	84.1	0.349	6.2	0.550	9.7
XIII.	St'd diet II + plasmon	7.308	6.445	88.0	0.440	6.2	0.423	5.7
XIV.	St'd diet III (p. 12)	8.330	7.520	90.4	0.379	4.5	0.428	5.1
XV.	St'd diet III + l. leucin	8.357	7.383	88.4	0.415	4.9	0.564	6.7
XVI.	St'd diet III	8.495	7.490	88.1	0.347	4.1	0.658	7.8

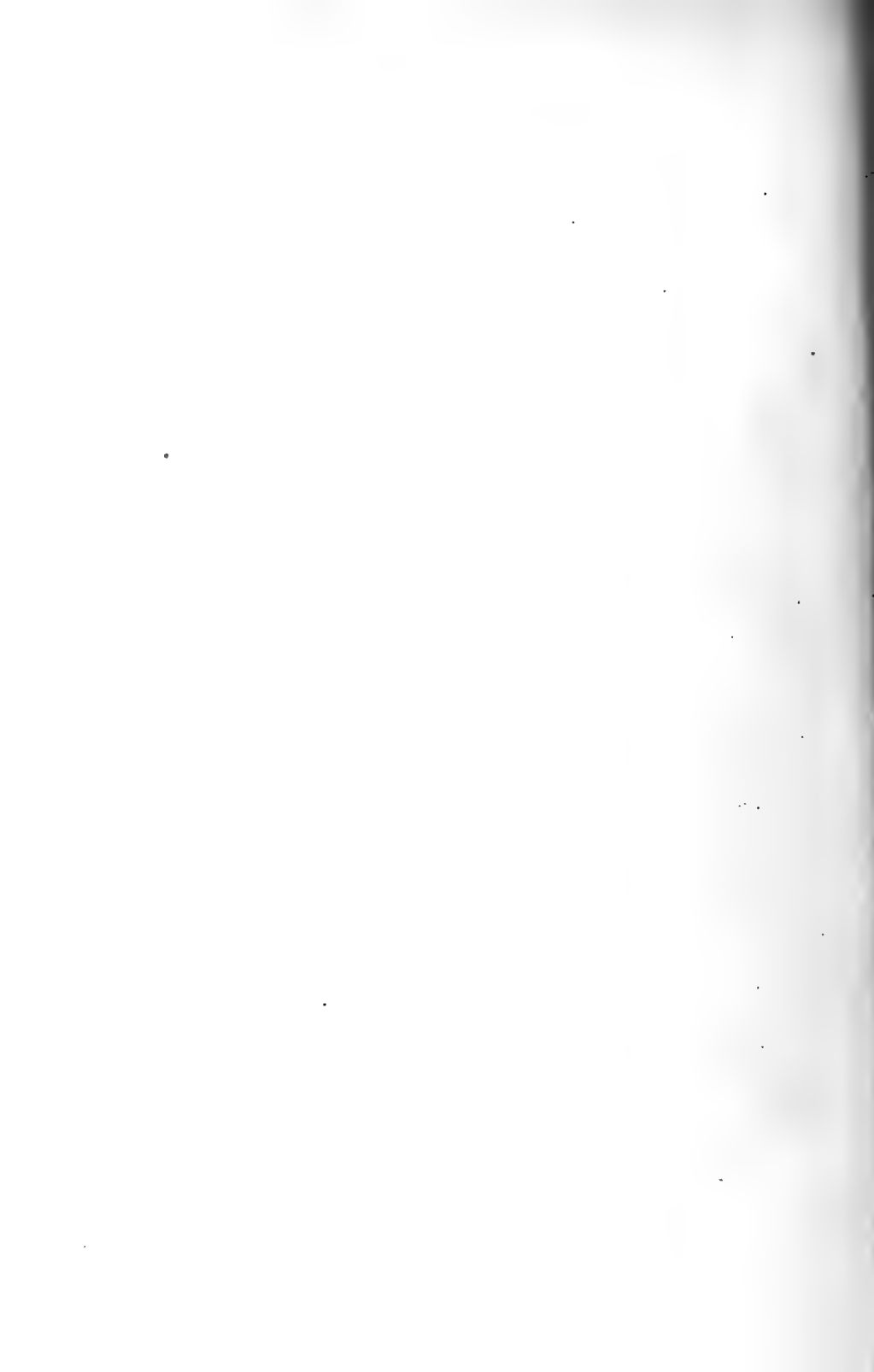



## INDEX TO VOL. XXV.

---

**A**BSORPTION, fat, xxviii.

, peritoneal, xv.

Acapnia, 310, 385.

Alcohol, effect on metabolism, xi.

Amino-acids, a source of sugar, xix.

Ammonia, elimination, 214.

—, metabolism after thyroidectomy, 403.

Anæsthesia, apnœa vera in, xiii.

Antibodies, concentration in body fluids, 202.

Apnœa, after excessive respiration, 310.

Apnœa vera, in anæsthesia, xiii.

AUER, J. The effect of severing the vagi or the splanchnics or both upon gastric motility in rabbits, 334.

AUER, J., and S. J. MELTZER. The influence of calcium upon the pupil and the pupillomotor fibres of the sympathetic nerve, 43.

**B**ALDWIN, W. M. The relation of the pancreas to sugar metabolism, xxi.

Barium, antagonism to magnesium, xvii.

—, elimination, 142.

BECHT, F. C. See GREER and BECHT, 202.

BENEDICT, S. R. See MENDEL and BENEDICT, 1, 23.

Blood pressure, in sheep, 433, xvii.

Blood, venous, affected by exercise, xxiv.

BUNZEL, H. H. See WOODRUFF and BUNZEL, 190.

**C**ALCIUM, excretion, 23.

—, influence on nerves of pupil, 43.

Cammidge reaction, xiv.

CARLSON, A. J. See DAVIS and CARLSON, 173.

CARLSON, A. J. See HEKTOEN and CARLSON, xix.

CARLSON, A. J., and CLARA JACOBSON. The depression of the ammonia-destroying power of the liver after complete thyroidectomy, 403.

CARPENTER, T. M., and J. R. MURLIN.

The energy metabolism of parturient women, xxvi.

CARREL, A., G. M. MEYER, and P. A. LEVENE. The influence of the removal of fragments of the intestinal tract on the character of nitrogen metabolism.

—II. The removal of the small intestines, 439.

Catalase, in echinoderm eggs, 190.

Circulation, peripheral flow varies with temperature, xviii.

**D**AVIS, B. F., and A. J. CARLSON.

Contribution to the physiology of lymph. — IX. Notes on the leucocytes in the neck lymph, thoracic lymph, and blood of normal dogs, 173.

DOLLEY, D. H. The neurocytological reaction in muscular exertion. — I. Preliminary communication. The sequence of the immediate changes in the Purkinje cells, 151.

DRESBACH, M. Observations upon the blood pressure of the sheep, 433, xvii.

**E**GG, chemistry of yolk-platelets and pigment, 195.

, echinoderm, fertilization affected by neutral salts, xxiii.

, relation of catalase to fertilization, 190.

Eye, origin in vertebrates, 77.

Electrolytes, action on muscle and nerve, xxii.

ERLANGER, JOSEPH. Mammalian heart strips together with a theory of cardiac inhibition, xvi.

Exercise, effect on venous pressure, xxiv.

**F**AT, absorption, xxviii.

Ferments, affected by shaking, 81.

Ferment, glycogenolytic, 255.

- Fishes, integumentary nerves of, 77.
- FLEISHER, M. S., and L. LOEB. The absorption of fluid from the peritoneal cavity, xv.
- GLYCOSURIA**, distribution of ferment, 255.
- GOFHAM, L. W., and A. W. MORRISON. The action of the proteins of blood upon the isolated mammalian heart, 419.
- GREER, J. R., and F. C. BECHT. A study of the concentration of antibodies in the body fluids of normal and immune animals, 292.
- HEART**, action of blood proteins on, 419.
- , metabolism during inhibition, xxv.
- , rigor, related to vagus stimulation, 113.
- , theory of inhibition, xvi.
- HEKTOEN, L., and A. J. CARLSON. On the distribution of immune bodies in the body fluids of immune animals, xix.
- HENDERSON, Y. Acapnia and shock. — IV. Fatal apnœa after excessive respiration, 310.
- HENDERSON, Y. Acapnia and shock. — V. Failure of respiration after intense pain, 385.
- HENDERSON, Y. An observation on the chemical regulation of respiration, xii.
- HENDERSON, Y. See SCARBROUGH and HENDERSON, xiii.
- HEWLETT, A. W. The effect of varying room temperatures upon the peripheral blood flow, xviii.
- HILDITCH, W. W. See MENDEL and HILDITCH, xi.
- HILDITCH, W. W. See UNDERHILL and HILDITCH, 66.
- HOOKE, D. R. (with J. M. WOLFSOHN). The effect of exercise upon the venous pressure, xxiv.
- HOSKINS, R. G. Congenital thyroidism: an experimental study of the thyroid in relation to other glands with internal secretion, xii.
- IMMUNE** bodies, distribution, xix.
- Inhibition, cardiac, metabolism in, xxv.
- , cardiac, theory of, xvi.
- Inorganic compounds, excretion, 1, 23.
- Intestine, regeneration of nerve and muscle, 367.
- , removal of segments influences metabolism, 231, 439.
- Ions, relation to toxicity, 190.
- JACOBSON**, C. See CARLSON and JACOBSON, 403.
- JOSEPH, D. R., and S. J. MELTZER. The effect of subminimal stimulation of the pneumogastric nerves upon the onset of cardiac rigor, 113.
- JOSEPH, D. R., and S. J. MELTZER. The mutual antagonistic life-saving action of barium and magnesium, — a demonstration, xvii.
- KETRON**, L. W. See WOLFSOHN and KETRON, xxv.
- LEVENE**, P. A., and G. M. MEYER. The elimination of total nitrogen, urea, and ammonia following the administration of some aminoacids, glycyglycin, and glycyglycin anhydrid, 214.
- LEVENE, P. A. See CARREL, MEYER, and LEVENE, 439.
- LEVIN, I., D. D. MANSON, and P. A. LEVENE. The influence of the removal of segments of the gastrointestinal tract on the character of protein metabolism, 231.
- LEVINE, P. A. See LEVIN, MANSON, and LEVINE, 231.
- LILLIE, R. S. The action of isotonic solutions of neutral salts on unfertilized echinoderm eggs, xxiii.
- LILLIE, R. S. The sensitizing and desensitizing action of various electrolytes on muscle and nerve, xxii.
- Liver, ammonia-destroying power depressed by thyroidectomy, 403.
- LOEB, L. See FLEISHER and LOEB, xv.
- LUCKHARDT, A. B. Contributions to the physiology of lymph. — X. The comparative electrical conductivity of lymph and serum of the same animal, and its bearing on theories of lymph formation, 345.
- LUSK, G. See RINGER and LUSK, xix.
- LUSSKY, H. O. Contributions to the physiology of lymph. — XI. The fractional coagulation of lymph, 354.

- Lymph, conductivity related to formation of, 345.  
 —, fractional coagulation, 354.  
 —, leucocytes in, 173.
- LYON, E. P. The catalase of echinoderm eggs before and after fertilization, 199.
- MACLEOD, J. J. R., and R. G. PEARCE. Studies in experimental glycosuria. — V. The distribution of glycogenolytic ferment in the animal body, especially of the dog, 255.
- Magnesium, antagonism to barium, xvii.  
 —, excretion, 1.
- MANSON, D. D. See LEVIN, MANSON, and LEVINE, 231.
- MCCLENDON, J. F. On the nucleo-albumen in the yolk platelets of the frog's egg, with a note on the black pigment, 195.
- MCCOLLUM, E. V. Nuclein synthesis in the animal body, 120.
- MEEK, W. J. The regeneration of nerve and muscle of the small intestine, 367.
- MELTZER, S. J. See AUER and MELTZER, 43.
- MELTZER, S. J. See JOSEPH and MELTZER, 113, xvii.
- MELTZER, S. J. See SHAKLEE and MELTZER, 81.
- MENDEL, L. B., and S. R. BENEDICT. The paths of excretion for inorganic compounds. — IV. The excretion of magnesium, 1.
- MENDEL, L. B., and S. R. BENEDICT. The paths of excretion for inorganic compounds. — V. The excretion of calcium, 23.
- MENDEL, L. B., and W. W. HILDITCH. The influence of alcohol upon metabolism, xi.
- Metabolism, affected by aminoacids, glycylglycin and glycylglycin anhydrid, 214.  
 —, after removal of segments of the intestine, 231, 439.  
 —, heart, xxv.  
 —, influenced by alcohol, xi.  
 —, influence of salicylic acid, 34.  
 —, in parturient women, xxvi.  
 —, carbohydrate, affected by removal of thyroids, 66.  
 —, of sugar, from amino-acids, xix.  
 —, of sugar, related to pancreas, xxi.
- MEYER, G. M. See CARREL, MEYER and LEVENE, 439.
- MEYER, G. M. See LEVENE and MEYER, 214.
- MEYER, G. M. The elimination of barium, 142.
- MORRISON, A. W. See GORHAM and MORRISON, 419.
- MURLIN, J. R. See CARPENTER and MURLIN, xxvi.
- Muscle, action of electrolytes on, xxii.  
 —, neurocytological reaction in contraction, 151.  
 —, regeneration in intestine, 367.
- NERVE, action of electrolytes on, xxii.  
 —, regeneration in intestine, 367.  
 —, vagus, in cardiac rigor, 113.  
 —, vagus, relation to cardiac inhibition, xxv.
- Nerves, of stomach, 334.  
 —, integumentary, of fishes, 77.  
 —, to pupil, influenced by calcium, 43.
- Nitrogen, excretion, 214.
- Nuclein synthesis, 120.
- PAIN, a cause of shock, 385.  
 Pancreas, function in sugar metabolism, xxi.
- PARKER, G. H. The integumentary nerves of fishes as photoreceptors and their significance for the origin of the vertebrate eyes, 77.
- PEARCE, R. G. See MACLEOD and PEARCE, 255.
- Peritoneum, absorption from, xv.
- Pigment, in frog's egg, 195.
- Pregnancy, energy metabolism in, xxvi.
- Proceedings of the American Physiological Society, ix.
- Pupil, nerves influenced by calcium, 43.
- Purkinje cells, changes in muscular exertion, 151.
- RESPIRATION, chemical regulation, xii.  
 —, excessive, a cause of shock, 310.
- Rigor, of heart, affected by vagus, 113.
- RINGER, A. I., and G. LUSK. The production of sugar from aminoacids, xix.
- ROCKWOOD, E. W. The influence of the isomers of salicylic acid on metabolism, 34.
- SALICYLIC acid, influence on metabolism, 34.
- SCARBROUGH, M. M., and Y. HENDERSON. Apnœa vera in anæsthesia, xiii.

- SHAKLEE, A. O., and S. J. MELTZER. The destructive effect of shaking upon the proteolytic ferments, 81.
- Shock, after excessive respiration, 310.
- , after intense pain, 385.
- SNYDER, C. D. Why do temperature coefficients of physiological processes increase for the lower ranges and decrease for the higher ranges of temperature, xxvii.
- Stomach, motility related to vagi and splanchnic nerves, 334.
- STOOKEY, L. B. A possible significance of the Cammidge reaction, xiv.
- Sugar, production from aminoacids, xix.
- Synthesis, of nuclein, 120.
- T**EMPERATURE, coefficients at different temperatures, xxvii.
- Thyroidectomy, relation to increase in ammonia, 403.
- Thyroidism, congenital, xii.
- Thyroids, removal affects carbohydrate metabolism, 66.
- Toxicity of salts and acids, 190.
- U**NDERHILL, F. P., and W. W. HILDITCH. Certain aspects of carbohydrate metabolism in relation to the complete removal of the thyroids and partial parathyroidectomy, 66.
- Urea, elimination, 214.
- V**AGUS nerve, affects cardiac rigor, 113.
- W**HITEHEAD, R. H. The absorption of fat stained by Sudan III, xxviii.
- WOLFSOHN, J. M., and L. W. KETRON. The gaseous metabolism of the dog's heart during vagus inhibition, xxv.
- WOLFSOHN, J. M. See HOOKER and WOLFSOHN, xxiv.
- WOODRUFF, L. L., and H. H. BUNZEL. The relative toxicity of various salts and acids toward paramecium, 190.







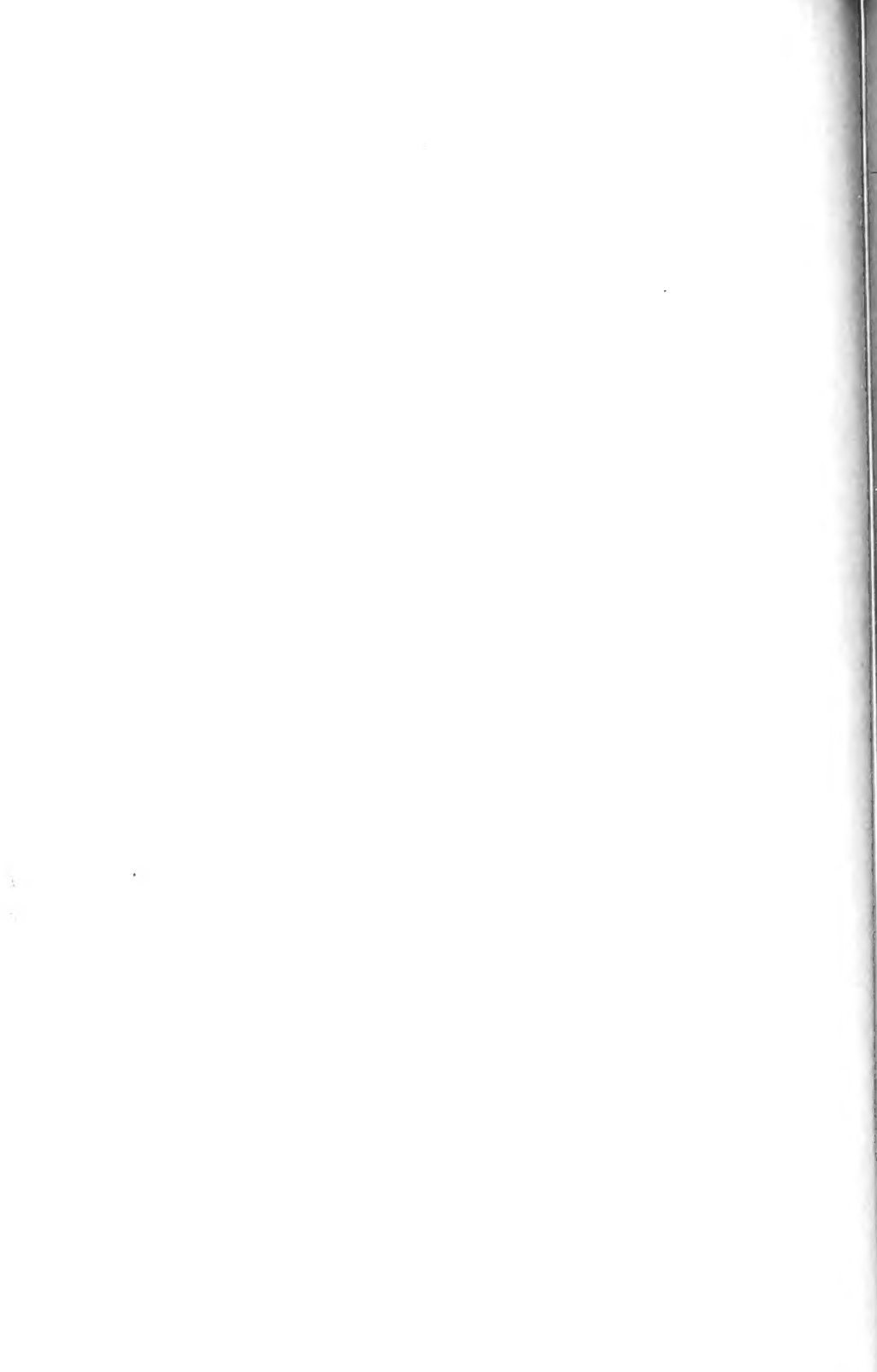



QP American Journal of Physiology  
1  
A5  
v.25  
cop.2

Biological  
& Medical  
Serials

PLEASE DO NOT REMOVE  
CARDS OR SLIPS FROM THIS POCKET

---

UNIVERSITY OF TORONTO LIBRARY

---

**STORAGE**

